

## Technical Description:

The equipment under test (EUT) is a 3 CD Changer Hi-Fi System. The EUT contains a Bluetooth module. The Bluetooth module in the EUT is operating in the frequency range from 2402MHz to 2480MHz (79 channels with 1MHz channel spacing). The EUT is powered by 120VAC. The EUT is using adaptive frequency hopping in the Bluetooth module as declared by the applicant.

The brief circuit description is listed as follows:

### 1. Bluetooth RF module IC701 (BM84)

BM84 is a module which fully supports the features and functional compliance of Bluetooth 3.0 standards. This module operates in 2.4GHz frequency bands.

BL3231 consists of:

- 1) U1 (IS1684S) acts as the radio core of the Bluetooth Module.
- 2) U2 (24C32) is the EEPROM for parameter setup for the Bluetooth module.
- 3) X1 provides system clock (oscillation frequency 16MHz) for U1.

### 2. Main Unit

- 1) IC301 (AN7316) is the pre-amplifier for the cassette player.
- 2) IC501 (MC5502) is the driver for the LCD display.
- 3) IC201 (SI4731) is the AM/FM radio receiver.
- 4) IC703 (UTC4558) acts as dual operational amplifier for the audio signal from BM84.
- 5) X201 and Y1 (32.768kHz) provide clock signal for IC201 and MCU (U1) respectively.
- 6) U1 (SC9671B) is the MCU for the 3CD Changer Hi-Fi System.
- 7) IC102 (SC7314) is the 4 channel stereo audio processor.
- 8) U3 (SA1461) is the motor driver for the CD player.
- 9) Y2 (12MHz) provides master clock for the MCU (U1).
- 10) U2 (M25Q40) is the serial flash memory for the MCU (U1).
- 11) IC101 (BA5417) is power amplifier for the cassette player.
- 12) U4 (AT24C02) is the serial EEPROM for the MCU (U1).
- 13) IC7 and IC8 (TA7291S) are bridge drivers for motor driving of the cassette and CD players.
- 14) IC2 (KA7805V) and IC4 (CYT81117) provide 5V and 3.3V for MCU (U1) and Bluetooth (IC701) respectively.

Antenna Used:

An internal, integral antenna has been used.

Antenna Gain: 0dBi

Production tolerance: -3dBm (Minimum) to +5dBm (Maximum)

## BM84

# Bluetooth 3.0+EDR Wireless Speaker Module

## Product Description

The ISSC BM84 is a highly integrated Bluetooth 3.0+EDR stereo module, designed for high data rate, short-range wireless communication in the 2.4 GHz ISM band. With ISSC Bluetooth stack and profile, the ISSC BM84 provides a low power and ultra-low cost Bluetooth 3.0+EDR solution for wireless voice/audio applications.

## Features

- Main Chip: ISSC IS1684S
- Bluetooth 3.0+EDR compliant
- Typical +2dBm Class 2 output power
- Receiver Sensitivity: GFSK typical -91dBm,  $\pi/4$  PSK typical -92dBm, 8DPSK typical -84dBm
- Piconet and Scatter net support
- HCI UART interface
  
- SBC decode for Bluetooth audio streaming
- Build-in High performance stereo audio codec
- Cap-less/single end headphone driver
- Audio DAC: 94dB SNR
- Build in Max. 350mAH Li-ion battery charger
- A2DP, AVRCP Profile support
- 3V operating voltage
- ROM version: 32Kb EEPROM
- 36 pins for SMT module(with additional 35th pin antenna port for external antenna option)
  
- Size: 15mm x29mm
- Build-in PCB Antenna
- RoHS compliant

**Device Pinout Diagram**

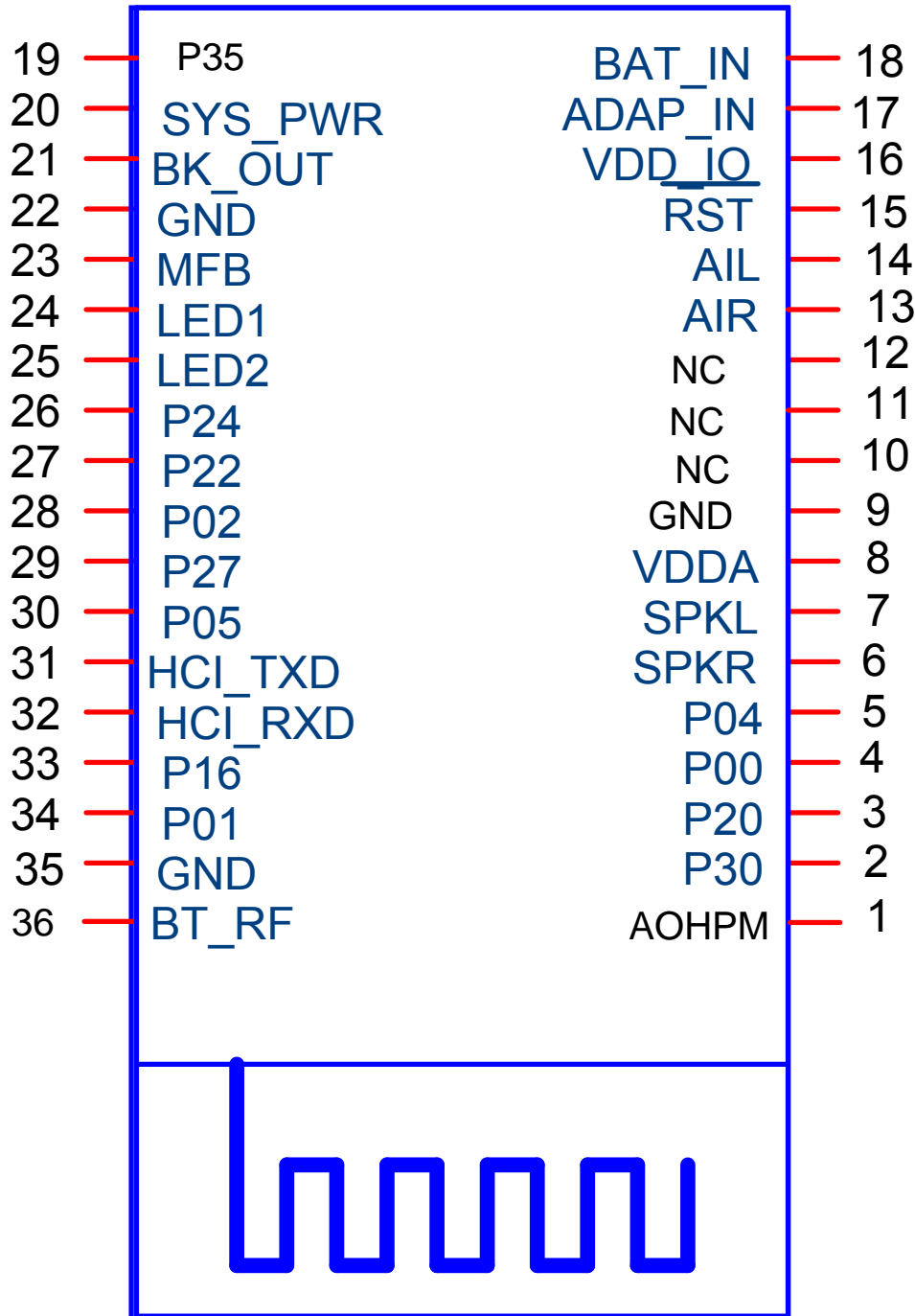

## Pin Definition

Pin No.	I/O	Name	Description
1	AO	AOHPM	SPK-(Onle for Capless out put)
2	P	P30	GPIO, default pull-high input Line-in detection, 1: no line-in detected; 0: line-in detected
3	I/O	P20	GPIO, default pull-high input System Configuration, H: Application L: Baseband(IBDK Mode)
4	I/O	P00	GPIO, default pull-low input. Slide Switch Detector
5	I/O	P04	GPIO, default pull-high input Audio AMP Enable
6	AO	SPKR	R-channel analog headphone output, single-ended application only
7	AO	SPKL	L-channel analog headphone output, single-ended application only
8	AP	VDDA	Reserve for external cap to fine tune audio frequency response
9	AP	AGND	Audio ground
10		NC	
11		NC	
12		NC	
13	AI	AIR	Stereo analog line in, R-channel
14	AI	AIL	Stereo analog line in, L-channel
15	I/O	RST_N	System Reset Pin
16	P	VDDIO	VDDIO pin, for calibration only Do not add external power to this pin
17	P	adap_in	Power adaptor input
18	P	bat_in	battery input
19	I/O	P35	GPIO P35
20	P	SYS_PW	System power output
21	P	bk_out	buck feedback sense pin
22	P	GND	Ground

23	P	MFB	Multi-Function Push Button key Combined Play/Pause key when A2DP enabled.
24	P	LED1	LED Driver 1
25	P	LED2	LED Driver 2
26	I/O	P24	GPIO, default pull-high input System Configuration, H: Boot Mode
27	I/O	P22	GPIO, default pull-low input. External LDO enable
28	I/O	P02	GPIO, default pull-high input PLAY/PAUSE button
29	I/O	P27	GPIO, default pull-high input Foward button
30	I/O	P05	GPIO, default pull-high input REW button
31	O	HCI_TXD	HCI TX data
32	I	HCI_RXD	HCI RX DATA
33	I/O	P16	GPIO, default pull-high input Volumn down button
34	I/O	P01	GPIO, default pull-high input Volumn up button
35	P	GND	Ground
36	AIO	BT_RF	NC for on board PCB antenna Antenna matching if an external antenna is used

## **Bluetooth 3.0(EDR) Multimedia SOC**

### **1. General Description**

ISSC IS1684S is a compact, high integration, ultra-low cost, CMOS single-chip RF + baseband IC for Bluetooth v3.0(EDR) (Enhanced Data Rate) 2.4GHz applications. This chip is fully compliant with Bluetooth specification and completely backward-compatible with Bluetooth 1.1, 1.2, 2.0 or 2.1 systems.

It incorporates Bluetooth 1M/2M/3Mbps RF, single-cycle 8051, TX/RX modem, memory controller, task/hopping controller, UART interface, and ISSC Bluetooth software stack to achieve the required Bluetooth v3.0(EDR) functions.

The IS1684S is designed to support high quality audio applications, an audio engine and a high performance stereo DAC are integrated for this purpose.

The audio engine supports the SBC audio decoding and equalizer to offer the best audio quality.

In addition, to minimize the external components required for portable devices, a voltage sensor for battery, Li-ion battery charger, a switching regulator and LDOs are integrated to reduce BOM cost for various Bluetooth applications.

The device incorporates built-in self-test (BIST) and auto-calibration functions to simplify production test.

## 2. Features

### System Specification

- Compliant with Bluetooth Specification v.3.0 (EDR) in 2.4 GHz ISM band

### Baseband Hardware

- 16MHz main clock input
- Built-in internal ROM for program memory
- Built-in 32 KB RAM for data storage and baseband data transfer buffering
- Enhanced Power Control
- Bluetooth 2.1 features
  - Encryption Pause and Resume
  - Erroneous Data Reporting
  - Extended Inquiry Response
  - Link Supervision Timeout Changed Event
  - Non-Flushable Packet Boundary Flag
  - Secure Simple Pairing
  - Sniff Subtracting
- Support both Pico-net and Scatter-net applications
- Hard-wired logic for modulation, demodulation, access code correlation, whitening, forward error correction (FEC), header error check (HEC), shorten hamming code, CRC generation/checking, frame check sequence (FCS), encryption bit stream generation, and transmit pulse shaping
- Adaptive Frequency Hopping (AFH) avoids occupied RF channels

- Fast Connection supported

#### **RF Hardware**

- Fully Bluetooth 3.0 (EDR) system in 2.4 GHz ISM band.
- Combined TX/RX RF terminal simplifies external matching and reduces external antenna switches.
- Max. +4dBm output power with 20 dB level control from register control.
- Build-in T/R switch for Class 2/3 application
- Build-in channel filter.
- To avoid temperature variation, temperature sensor with temperature calibration is utilized into bias current and gain control.
- Fully integrated synthesizer has been created. There requires no external VCO, varactor diode, resonator and loop filter.
- Crystal oscillation with build-in digital trimming for temperature/process variations.

#### **Audio processor**

- SBC decoding
- Packet error concealment

#### **Audio Codec**

- 16 bit stereo codec
- 94dB SNR DAC playback
- Integrate headphone amplifier for 16Ω speakers

### **Peripherals**

- Built-in Lithium-ion battery charger
- Integrate 3V, 1.8V LDO and Switching mode regulator
- Built-in 10-bit Aux-ADC for battery monitor and voltage sense.
- LED driver

### **Flexible HCI interface**

- High speed HCI-UART (Universal Asynchronous Receiver Transmitter) interface

### **Package**

- 7x7mm<sup>2</sup> 56 pins, 0.4mm pitch SAW QFN standard package

### 3. Functional Diagram

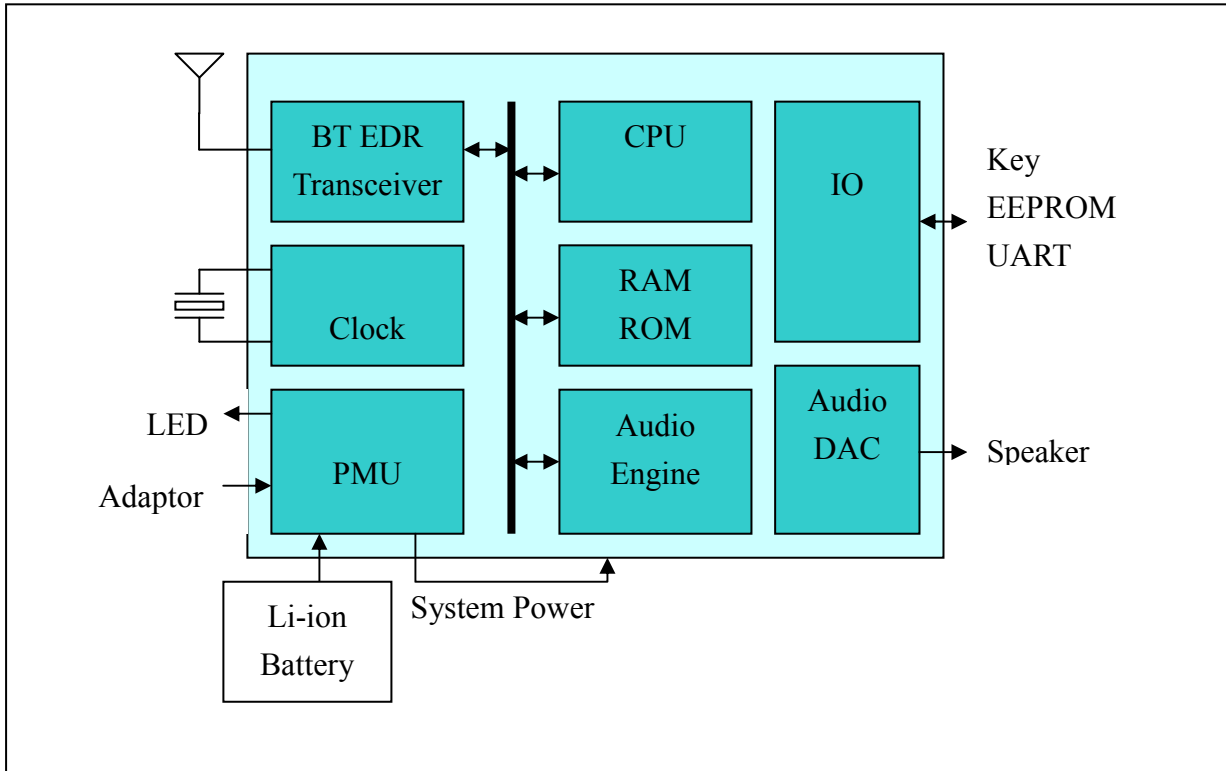

#### 4. Pin Assignment

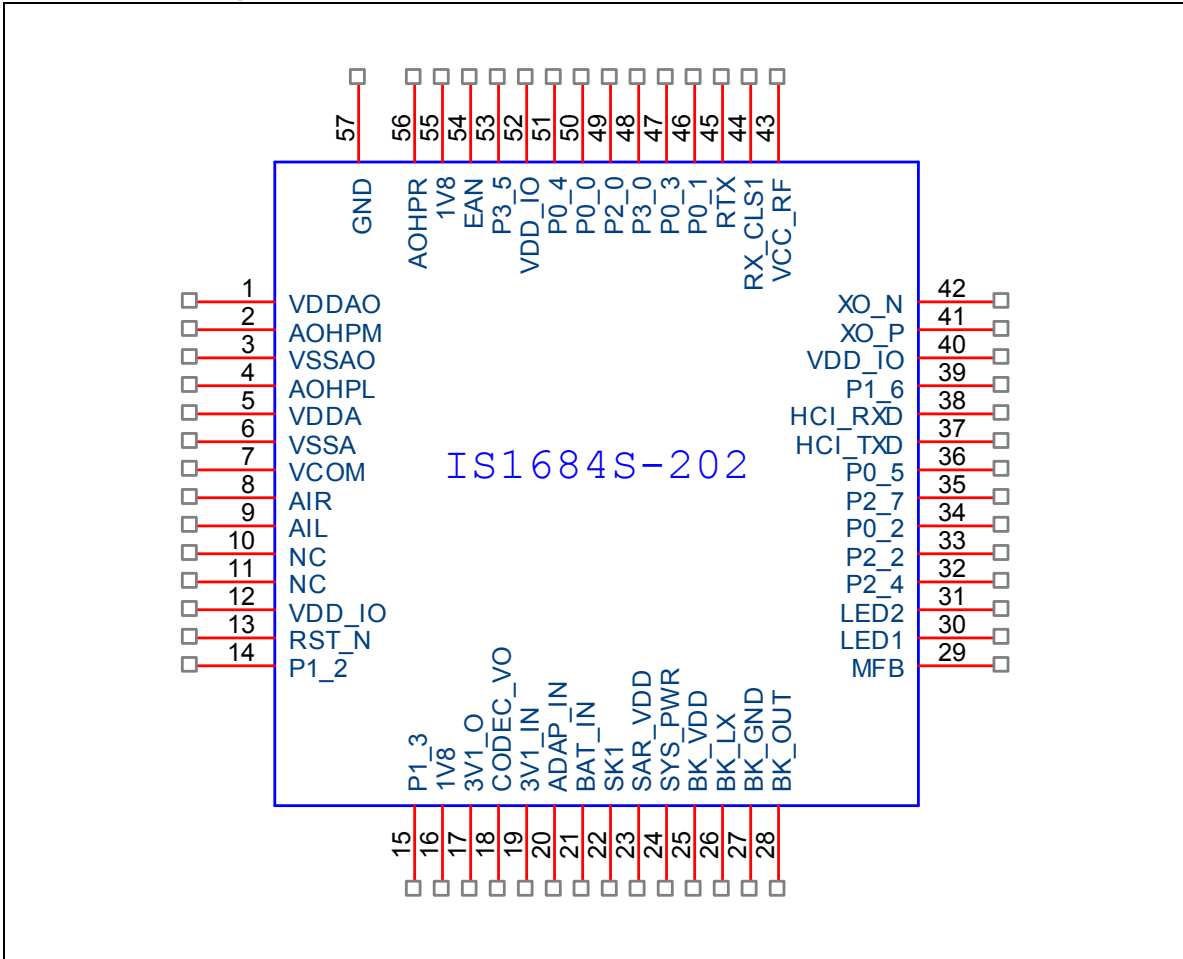

## 5 Pin Descriptions

Pin No.	I/O	Pin Name	Pin Descriptions
1	P	VDDAO	Positive power supply dedicated to CODEC output amplifiers.
2	AO	AOHPM	Headphone common mode output/sense input
3	P	VSSAO	Negative power supply dedicated to CODEC output amplifiers
4	AO	AOHPL	L-channel analog headphone output
5	P	VDDA	Positive power supply/reference voltage for CODEC
6	P	VSSA	Negative reference/power supply for CODEC
7	AO	VCOM	Internal biasing voltage for CODEC
8	AI	AIR	R-channel single-ended analog inputs
9	AI	AIL	L-channel single-ended analog inputs
10	NC		
11	NC		
12	P	VDD_IO	I/O power supply input
13	AI	RST_N	KEY PIN for FT Test System Reset Pin
14	I/O	P1_2	GPIO, default pull-high input KEY PIN for FT Test EEPROM clock SCL Clock signal for OLED
15	I/O	P1_3	GPIO, default pull-high input KEY PIN for FT Test EEPROM data SDA Data signal for OLED
16	P	1V8	Core 1.8V power input
17	P	3V1_O	3.1V LDO output
18	P	CODEC_VO	3.1V LDO output for CODEC power
19	P	3V1_VIN	3.1V LDO input
20	P	ADAP_IN	Power adaptor input
21	P	BAT_IN	Battery input
22	AI	SK1	ADC analog input 1

Pin No.	I/O	Pin Name	Pin Descriptions
23	P	SAR_AVDD	SAR 1.8V input
24	P	SYS_PWR	System Power Output
25	P	BK_VDD	Buck VDD Power Input
26	P	BK_LX	Buck feedback input
27	P	BK_GND	Buck Ground
28	P	BK_OUT	Buck output
29	P	MFB	Multi-Function Push Button key, push high
30	AI	LED1	LED Driver 1
31	AI	LED2	LED Driver 2
32	I/O	P2_4	GPIO, default pull-high input KEY PIN for FT Test System Configuration, H: Boot Mode
33	I/O	P2_2	GPIO, default pull-low input. Keep alive for external LDO power enable application.
34	I/O	P0_2	GPIO, default pull-high input Play/Pause key as the default setting
35	I/O	P2_7	GPIO, default pull-high input FWD key when class 2 RF FWD key(short press) when class 1 RF
36	I/O	P0_5	GPIO, default pull-high input KEY PIN for FT Test REV key when class 2 RF REV key(short press) when class 1 RF
37	O	HCI_TXD	KEY PIN for FT Test HCI TX data
38	I	HCI_RXD	KEY PIN for FT Test HCI RX data
39	I/O	P1_6	GPIO P1_6, default pull-high input Volume down key when class 2 RF Audio AMP Enable when class 1 RF
40	P	VDD_IO	I/O power supply input
41	I	XO_P	16MHz Crystal input positive

Pin No.	I/O	Pin Name	Pin Descriptions
42	I	XO_N	16MHz Crystal input negative
43	RP	VCC_RF	RF power input for both synthesizer and TX/RX block
44	I	RX_CLASS1	Class1 RF RX path
45	I/O	RTX	Class2 RTX path; Class1/Class2 TX path
46	I/O	P0_1	GPIO, default pull-high input Volume up key when class 2 RF. Class1 Control signal of external TR switch when class 1 RF
47	I/O	P0_3	GPIO, default pull-high input KEY PIN for FT Test UART RX_IND when class 2 RF Class1 Control signal of external TR switch when class 1 RF
48	I/O	P3_0	GPIO, default pull-high input Line-in Detector (Low Active)
49	I/O	P2_0	GPIO, default pull-high input KEY PIN for FT Test System Configuration, H: Application L: Baseband(IBDK Mode)
50	I/O	P0_0	GPIO, default pull-low input. KEY PIN for FT Test Slide Switch Detector/TX_IND when class 2 RF
51	I/O	P0_4	GPIO, default pull-high input Audio AMP Enable when class 2 RF
52	P	VDD_IO	I/O power supply input
53	I/O	P3_5	GPIO 3_5, default pull-high input. Buzzer Signal Output
54	I	EAN	Embedded ROM/External Flash enable H: Embedded; L: External Flash
55	P	1V8	Core 1.8V power input
56	AO	AOHPR	R-channel single ended analog headphone output
57	P	GND	Exposed pad as ground

Application Note for GPIO Setting:

- 1) KEY PIN for FT Test  
HCI\_RXD, HCI\_TXD, RST\_N, P2\_0, P2\_4, P1\_3, P1\_2, P0\_3, P0\_5, P0\_0
- 2) For Class2 RF application: VOL+:P0\_1, VOL-: P1\_6, FWD:P2\_7, REV:P0\_5, AUDIO AMP ENABLE: P0\_4
- 3) For Class1 RF application: VOL+:P2\_7(Long Press), VOL-: P0\_5(Long Press), FWD:P2\_7(Short Press) , REV: P0\_5(Short Press) , AUDIO AMP ENABLE: P1\_6
- 4) Play/Pause: P0\_2
- 5) P1\_2:EEPROM Clock/Clock Signal for OLED(5028-202 not support)  
P1\_3:EEPROM Data/Data Signal for OLED(5028-202 not support)
- 6) SLIDE SWITCH DETECT: P0\_0
- 7) Buzzer Signal Output: P3\_5
- 8) CLASS 1 RF TX: P0\_1, CLASS 1 RF RX: P0\_3
- 9) External LDO power enable keep alive: P2\_2
- 10)System Configuration: P2\_0, P2\_4
- 11)P0\_0/P0\_3 are used as TX\_IND/RX\_IND of UART control in MCU application

## **6 Functional Description**

### **6.1 Overall Architecture**

The ISSC IS1684S integrates an enhanced EDR Bluetooth RF & BB core, HCI controller, audio engine and an ENHANCED 8051 processor with an internal mask ROM for program memory and SRAM for data memory. An innovative interconnection structure called the Common-Memory Architecture (CMA) is designed to provide a fast and flexible data movement scheme between the embedded processor, Bluetooth core, and peripheral hardware.

For audio application and power management, IS1684S has build-in an audio processor, mono codec and power management unit to reduce the external components.

### **6.2 Radio Frequency (RF)**

#### **6.2.1 Transmitter**

The internal PA has a maximum output power of +4dBm with level control 20dB from amplitude control. This is applied into Class 2/3 radios without external RF PA. For Class1 application, the build-in level control can be used with external PA for power control requirement.

The transmitter features IQ direct conversion to minimize the frequency drift. And it can excess 30dB power range with temperature compensation machine.

#### **6.2.2 Receiver**

The LNA can be operated into two type modes. One type is TR-combined mode for single port application. The other type is TR-separated mode for external PA/LNA application.

An ADC is used to sample input analogue wave for digital demodulation. Before the ADC, a channel filter has been integrated into receiver channel to increase the anti-interference capacity and also reduce the external component count.

For avoiding temperature variation issues, a temperature sensor with temperature calibration is utilized into bias current and gain control of LNA, Mixers, and RF AMP.

### 6.2.3 Synthesizer

The internal loop filter is used to reduce external RC components. This can reduce cost and variations for components. This internal LC tank for VCO is utilized to reduce variation for components. The cost is down at the same time.

A fully integrated synthesizer has been created. There requires no external VCO, varactor diode, resonator and loop filter.

### 6.3 MODEM

There are three different modulations for Bluetooth v3.0 (EDR). Table 6.3 summarizes these modulations and data rate.

Figure 6.3 Modulation type for Bluetooth v3.0 (EDR)

Data Rate	Modulation	Bits/Symbol
BDR: 1 Mbps	GFSK	1
EDR: 2 Mbps	$\pi/4$ DQPSK	2
EDR: 3 Mbps	8DPSK	3

**6.3.1 Basic Data Rate MODEM (BDR)**

On the Bluetooth v1.2 specification and below, 1 Mbps was the standard data rate based on Gaussian Frequency Shift Keying (GFSK) modulation scheme. This basic rate modem meets BDR requirements of Bluetooth v3.0(EDR) specification.

Figure 6.3.1 Data format for BDR

Access Code	Header	Payload
-------------	--------	---------

**6.3.2 Enhanced Data Rate MODEM (EDR)**

On the Bluetooth v3.0(EDR) specification, Enhanced Data Rate (EDR) has been introduced to provide 2 and 3 Mbps data rates as well as 1 Mbps. This enhanced data rate modem meets EDR requirements of Bluetooth v3.0(EDR) specification. For the viewpoint of baseband, both BDR and EDR utilize the same 1MHz symbol rate and 1.6 KHz slot rate. For BDR, 1 symbol represents 1 bit. However each symbol in the payload part of EDR packets represents 2 or 3 bits. This is achieved by using two different modulations,  $\pi/4$  DQPSK and 8DPSK.

Figure 6.3.2.A Data format for EDR

Access Code	Header	Guard	Sync	Payload	Trailer
-------------	--------	-------	------	---------	---------

For  $\pi/4$  DQPSK modulation, each symbol carries 2 bits of information. For its constellation diagram, although there are 8 possible phase states, the encoding scheme guarantees the trajectory of the modulation between symbols is restricted to 4 states. For a given starting

point, every phase change between symbols is restricted to  $+45^\circ$ ,  $+135^\circ$ ,  $-45^\circ$ , and  $-135^\circ$ .

Figure 6.3.2.B Phase shift & bit pattern for 2 MHz data rate

Phase Shift	Bit Pattern
$+45^\circ (+\pi/4)$	00
$+135^\circ (+3\pi/4)$	01
$-135^\circ (-3\pi/4)$	11
$-45^\circ (-\pi/4)$	10

For 8DPSK modulation, each symbol carries 3 bits of information. For its constellation diagram, it is similar to  $\pi/4$  DQPSK but the trajectory of the modulation between symbols has 8 possible phase states. For a given starting point, every phase change between symbols is restricted to  $0^\circ$ ,  $+45^\circ$ ,  $+90^\circ$ ,  $+135^\circ$ ,  $+180^\circ$ ,  $-135^\circ$ ,  $-90^\circ$ , and  $-45^\circ$ .

Figure 6.3.2.C Phase shift & bit pattern for 3 MHz data rate

Phase Shift	Bit Pattern
$0^\circ (+0)$	000
$+45^\circ (+\pi/4)$	001
$+90^\circ (+\pi/2)$	011
$+135^\circ (+3\pi/4)$	010
$+180^\circ (+\pi)$	110
$-135^\circ (-3\pi/4)$	111
$-90^\circ (-\pi/2)$	101

---

-45° ( $-\pi/4$ )	100
-------------------	-----

#### 6.4 Baseband

The following modules implemented in hardware constitute the Bluetooth Baseband Core. The frequency hopping sequence generator produces the correct hop frequency control sequence based on the Bluetooth clock, Bluetooth device address, and the current operating mode.

The access code generates the access code based on the Lower Address Part (LAP) of the Bluetooth device address. The access code is comprised of the preamble, sync word and trailer bits. The detection of the access code uses correlation to detect a valid access code.

Bluetooth uses two types of FEC: 1/3 repetition code and (15, 10) shorten Hamming code respectively. The former basically repeats each transmitted bit three times while the latter has 15 bits of codeword which contains 5 parity bits. The code has capability of correction of all single-bit errors in each codeword.

The purpose of HEC is to protect the header bits. Dedicated header error code generator calculates the HEC bits in the header of a transmitted packet. While on the receiver side, HEC detects corrupted headers.

A 16-bit CRC is adopted to protect payload data transmitted using certain types of Bluetooth packets.

Information confidentiality can be protected by encryption of the packet payload.

Dedicated encryption/decryption hardware is designed into the baseband core.

## 6.5 MCU

The embedded processor for IS1684S is a single-cycle 8051 CPU. The embedded processor will be referred to as simply the processor, 8051, or MCU throughout the remainder of this document. There are a few minor differences between a standard 8051 and this CPU. These include:

1. Alteration of memory timings to match internal and external memory configurations.
2. Modification of idle mode to disable internal CPU clocking. Only externally-clocked interrupt sources can allow the CPU to recover from idle mode.

A single-port synchronous interface is provided to memory. From this single port, the bandwidth is divided among the 7 interfaces spread amongst 5 physical busses described below:

- Embedded processor bus
- Baseband TX bus
- Baseband RX bus
- HCI TX bus
- HCI RX bus
- Audio bus
- DMA bus

In addition, attached to the embedded processor bus are a register bank, a dedicated single-port memory (data segment 1), and flash memory (program segment). The processor coordinates all link control procedures and data movement using a set of pointer registers. For example, when an HCI packet (from the host via USB or UART) is received into the HCI buffer, the processor is interrupted. The processor can then read a

status register to determine the HCI packet type and determine whether to set up the Baseband pointer registers for this memory region for RF-retransmission, or to otherwise directly perform packet processing with the CPU.

## **6.6 Bluetooth Clock and Timers**

A Bluetooth standard 28-bit counter running at 3.2 kHz implements the native clock defined by Bluetooth specification. This clock provides the transmission and receiving timing of a half time slot (312.5  $\mu$ s). Another finer counter implemented in 16 bits is also provided as the phase of a half time slot. This phase information is very helpful when a Bluetooth slave wants to adapt to its master's clock. The counter is pre-scalable for the purpose of power saving operations. The diagram below describes a standard Bluetooth native clock and master clock. The clock signal is also used as a slot boundary signal to trigger a baseband packet transmission or receipt.

There are several timers provided by the system, two timers for TX/RX and the others for general purpose.

The powerful pre-scheduling functions for the transceiver are realized different sets of programmable timers. Each set of timers is associated with the task of transmission or receiving. When the timer is configured by firmware, it will automatically execute the TX or RX task at a specific time. Sub-tasks and timing for a TX task remain to be defined.

Figure 6.6 Bluetooth clock

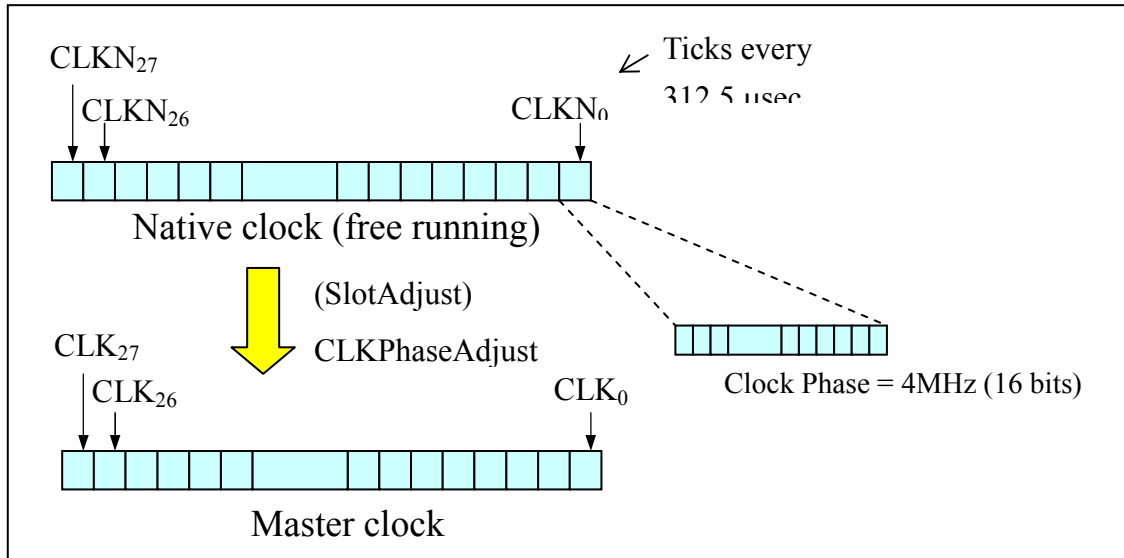

## 6.7 HCI Control Logic for USB/UART

Hardwired control logic is presented in front of the UART devices for HCI protocol handling and packet buffering. This control logic is part of the HCI controller defined in Bluetooth specification 1.2. This logic is partially responsible for the HCI protocol handling to/from the host and it also maps the registers of the UART devices indirectly to the 8051 such that the system can receive or send a HCI packet to/from the respective host interface. Major functions of this logic include:

- HCI packet formatter and de-formatter (identifying the packet type)
- Frame boundary determination, segmentation and reassembly of HCI packets.
- HCI packet transmission, receiving, and buffering (using common memory HCI buffer).
- Independent receive / transmit channels
- Universal device interface

### **6.7.1 HCI UART Interface**

An embedded HCI UART (Universal Asynchronous Receiver Transmitter) with programmable data rate up to 3Mbps is included in this design. The HCI UART supports the following functions:

- Full-Duplex operation
- Programmable BAUD rate (using 16-bit input clock divider to obtain Baud Rate x16 or x24 or x13 clock base)
- 7 or 8 Data bits
- 1 or 2 Stop bits
- Even / Odd / Mark / Space / None Parity configurations
- Break Generation / Detection
- Maskable individual interrupts to CPU and combined Error interrupt to HCI
- Selectable Direct CPU interface or interface to HCI module

### **6.8 General Purpose I/O**

The IS1684S provides 15 general purpose I/O ports. These general I/Os can be defined as input or output port individually by setting specific register bit. While setting as an input port, a build-in 50K $\Omega$  pull high or pull low resistor can be enabled for different application purpose.

### **6.9 Audio Processor**

The IS1684S builds in an enhanced audio engine to offer high quality of audio for audio application. The standard SBC A2DP audio function is implemented in the audio engine.

### 6.10 Audio DAC

The build in audio circuits contain a digital to analog converter (DAC) and a headphone driver. The DAC output is available for both line level and through the headphone amplifier to drive a low impedance headphone. The headphone output volume is adjustable by the combination of the digital/analog gain control.

Figure 6.10 Audio DAC

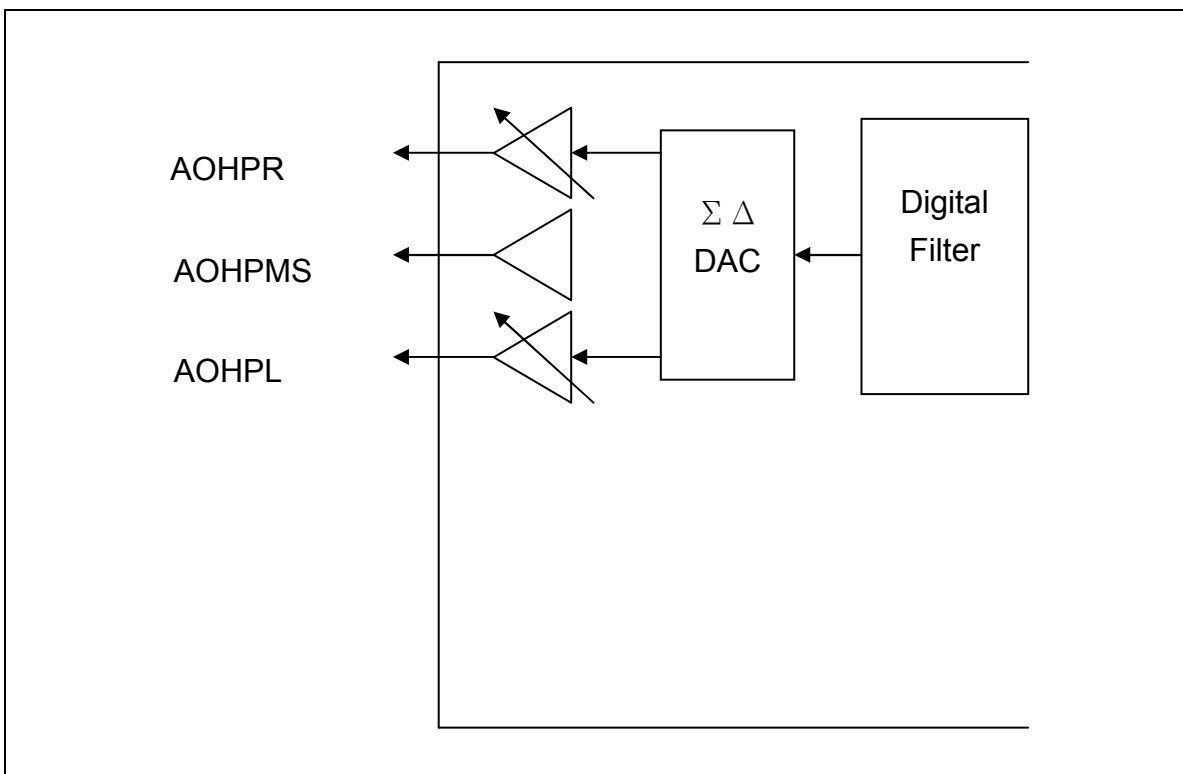

### 6.11 Auxiliary ADC

The 10-bit auxiliary analog to digital converter (SAR ADC) provides one dedicated channel for battery power detection and one other channel for external peripheral sensing. This ADC has 10 bits resolution that provides an accurate monitoring for battery voltage. The operating current is very low and almost consumes no power when disabled.

## **6.12 Power Management (PMU)**

The power management unit of IS1684S includes several power control blocks, linear regulators, switch-mode regulator, Aux-ADC, LED driver and Lithium-ion/Polymer battery charger.

### **6.12.1 3V1\_LDO**

The IS1684S has build-in the programmable output voltage LDOs (1.8~3.2V) for codec and digital IO power supply. The programmable LDO is used to regulate the high input voltage from battery or adapter. This LDO needs 1uF bypass capacitor.

### **6.12.2 Buck regulator**

The built-in programmable output voltage buck (1.8~2.4V) converts battery voltage for RF and baseband core power supply. This converter has high conversion efficiency and fast transient response.

### **6.12.3 Voltage Dectector**

The 10-bit Successive-Approximation analog to digital converter (SAR ADC) monitors the battery power and adapter power for charging and power management control.

### **6.12.4 Li-ion Battery Charger**

IS1684S includes a built-in battery charger optimized for use with lithium polymer batteries. The charger features a current sensor for charging control, user programmable current regulation and high accuracy voltage regulation. It charges the battery in four phases:

---

- reviving mode : 2mA charging current to charge BAT to 2.5V
- pre-charge mode : 0.1C charging current to charge BAT to 3.0V
- constant current mode : 0.xC (default 0.7C) charging current to charge BAT to 4.2V (programmable)
- constant voltage mode : charging is terminated while the charging current drops below 0.YC (default 0.13C)

Charging current in the constant current mode can be configured to provide a wide range of charging current up to 180mA (1mA per step). Charger will re-start charging if the battery voltage falls below an internal threshold.

System operation is allowed when the battery is charging.

### **6.13 Miscellaneous (Watchdog Timer, and Clock Divider)**

System related functions such as watchdog timer, Endian control, and interrupt vectors are also provided. The purpose of the watchdog timer is to provide a reset to CPU in case when the CPU fails to service the watchdog timer in a pre-defined (programmable) period.

## 7 Electrical Characteristics

### Absolute Maximum Ratings

Rating		Min	Max	Max
Operation Temperature		-20°C	+70°C	°C
Core supply voltage	VDD_CORE, VCC_RF, AVDD_SAR, AVDD_PLL	1.7V	1.98V	V
Codec supply voltage	VDD_AUDIO		3.3	V
I/O voltage	VDD_IO		3.3	V
Supply voltage	BK_VDD		4.7	V
	3V1_VIN		5	V
	BAT_IN		4.3	V
	ADAP_IN		6	V
	LED[1:0]		5	V
	Power switch		6	V

### Recommended Operate Condition

Symbol	Parameter	Min	Typical	Max	Unit
V <sub>DD18</sub>	Digital core supply voltage				
	SAR ADC supply voltage	1.62	1.8	1.92	V
	CODEC supply voltage				
V <sub>DDIO</sub>	I/O supply voltage	2.5	2.7	3.3	V
	RF supply voltage				
T <sub>OPERATION</sub>	Operating temperature range	-20	+25	+70	°C
T <sub>stg</sub>	Storage temperature	-40		+125	°C
V <sub>LDO</sub>	LDO supply voltage	1.8		3.3	V
V <sub>BAT_IN</sub>	Input voltage for SAR ADC	0.9		3.3	V

**Radio Characteristics:**  
**Transmitter section for BDR**

VCC_RF = 2.7V      Temperature = 25°C		Min	Typ	Max	Bluetooth specification	Unit
Maximum RF transmit power			3	4.0	-6 to 4	dBm
RF power variation over temperature range with compensation enabled			±2			dB
RF power control range			20		≥16	dB
RF power range control resolution			0.5			dB
20dB bandwidth for modulated carrier			900		≤1000	KHz
ACP	F = F <sub>0</sub> ±2MHz		-28		≤-20	dBm
	F = F <sub>0</sub> ±3MHz		-46		≤-40	dBm
	Note: F <sub>0</sub> =2441MHz		-54		≤-40	dBm
Δf <sub>1avg</sub> maximum modulation		150		165	140<Δf <sub>1avg</sub> <175	KHz
Δf <sub>2max</sub> maximum modulation		140		150	≥115	KHz
Δf <sub>2avg</sub> /Δf <sub>1avg</sub>		0.95	1		≥0.80	
ICFT (abs)		0	5	10	75	KHz
Drift rate (abs)		2		7	≤20	KHz/50μs
Drift (single slot packet, abs)			12		≤25	KHz
2 <sup>nd</sup> harmonic content @ Tx= 4dBm			-53		≤-47	dBm
3 <sup>rd</sup> harmonic content @ Tx= 4dBm			-55		≤-47	dBm

**Receiver section for BDR**

Temperature = 25°C	Frequency (GHz)	Min	Typ	Max	Bluetooth specification	Unit
Sensitivity at 0.1% BER for all basic rate packet types	2.402		-91		≤-70	dBm
	2.441		-91			
	2.480		-91			
Maximum received signal at 0.1% BER			-10		≥-20	dBm
C/I co-channel			5		≤11	dB
Adjacent channel selectivity C/I  Note: F <sub>0</sub> =2441MHz	F = F <sub>0</sub> +1MHz		-7		≤0	dB
	F = F <sub>0</sub> -1MHz		-7		≤0	dB
	F = F <sub>0</sub> +2MHz		-36		≤-30	dB
	F = F <sub>0</sub> -2MHz		-22		≤-9	dB
	F = F <sub>0</sub> -3MHz		-24		≤-20	dB
	F = F <sub>0</sub> +5MHz		-50		≤-40	dB
	F = F <sub>image</sub>		-22		≤-9	dB
Maximum level of intermodulation interferers			-38		≥-39	dB

**Transmitter Section for EDR**

Temperature = 25°C		Min	Typ	Max	Bluetooth specification	Unit
Relative transmit power			-1.6		-4 to 1	dB
π/4 DQPSK max carrier frequency stability	$ \omega_o $ freq. error		5		≤10 for all blocks	KHz
	$ \omega_i $ initial freq. error		10		≤75 for all blocks	KHz
	$ \omega_o+\omega_i $ block freq. error		10		≤75 for all blocks	KHz
8DPSK max carrier frequency stability	$ \omega_o $ freq. error		5		≤10 for all blocks	KHz
	$ \omega_i $ initial freq. error		10		≤75 for all blocks	KHz
	$ \omega_o+\omega_i $ block freq. error		10		≤75 for all blocks	KHz
π/4 DQPSK modulation accuracy @ Tx= 2dBm	RMS DEVM		7		≤20	%
	99% DEVM		Pass		≤30	%
	Peak DEVM			25	≤35	%
8DQPSK modulation accuracy @ Tx= 2dBm	RMS DEVM		7		≤13	%
	99% DEVM		Pass		≤20	%
	Peak DEVM			20	≤25	%

In-band spurious emissions  Note: $F_0=2441\text{MHz}$	$F > F_0+3\text{MHz}$		<-54		$\leq -40$	dBm
	$F = F_0-3\text{MHz}$		-46		$\leq -40$	dBm
	$F = F_0-2\text{MHz}$		-28		$\leq -20$	dBm
	$F = F_0-1\text{MHz}$		-30		$\leq -26$	dBm
	$F = F_0+1\text{MHz}$		-30		$\leq -26$	dBm
	$F = F_0+2\text{MHz}$		-28		$\leq -20$	dBm
	$F = F_0+3\text{MHz}$		-46		$\leq -40$	dBm
EDR differential phase encoding			100		$\geq 99$	%

**Receiver Section for EDR**

Temperature = 25°C	Frequency (GHz)	Modulation	Min	Typ	Max	Bluetooth specification	Unit	
Sensitivity at 0.01% BER	2.402	$\pi/4$ DQPSK		-92		$\leq -70$	dBm	
	2.441	$\pi/4$ DQPSK		-92				
	2.480	$\pi/4$ DQPSK		-92				
	2.402	8DPSK		-84		$\leq -70$	dBm	
	2.441	8DPSK		-84				
	2.480	8DPSK		-84				
Maximum received signal at 0.1% BER		$\pi/4$ DQPSK		-10		$\geq -20$	dBm	
		8DPSK		-10		$\geq -20$		
C/I co-channel at 0.1% BER		$\pi/4$ DQPSK		4		$\leq 13$	dB	
		8DPSK		5		$\leq 21$	dB	
Adjacent channel selectivity C/I	F = F <sub>0</sub> +1MHz	$\pi/4$ DQPSK		-14		$\leq 0$	dB	
		8DPSK		-8		$\leq 5$	dB	
	F = F <sub>0</sub> -1MHz	$\pi/4$ DQPSK		-13		$\leq 0$	dB	
		8DPSK		-8		$\leq 5$	dB	
	Note: F <sub>0</sub> =2441MHz	F = F <sub>0</sub> +2MHz	$\pi/4$ DQPSK		-38		$\leq -30$	dB
			8DPSK		-34		$\leq -25$	dB
	F = F <sub>0</sub> -2MHz	$\pi/4$ DQPSK		-21		$\leq -7$	dB	

		8DPSK		-21		$\leq 0$	dB
	$F = F_0 - 3\text{MHz}$	$\pi/4$ DQPSK		-27		$\leq -20$	dB
		8DPSK		-20		$\leq -13$	dB
		$F = F_0 + 5\text{MHz}$	$\pi/4$ DQPSK		-52		$\leq -40$
	8DPSK			-45		$\leq -33$	dB
	$F = F_{\text{image}}$		$\pi/4$ DQPSK		-21		$\leq -7$
		8DPSK		-21		$\leq 0$	dB

### Audio DAC

Test Condition: T= 25°C, Vdd=2.8V, 1KHz sine wave input, Bandwidth= 20~20KHz						
Parameter	Condition		Min.	Typ.	Max.	Unit
Output Level	Full scale			2.1		Vpp
Resolution			16			bits
Output Sampling Rate			8		48	KHz
SNR	$f_{in}=1\text{KHz}$ B/W=20~20KHz A-weighted THD+N < 0.01% 0dBFS signal Load=100K $\Omega$	8KHz		94		dB
		16KHz		94		dB
		32KHz		94		dB
		44.1KHz		94		dB
		48KHz		94		dB
Max Output Power	$R_L=16\text{Ohm}$			35		mW
	$R_L=32\text{Ohm}$			17		mW
THD+N	16Ohm load				0.05	%
	100K $\Omega$ load				0.01	%
Digital Gain			-54		4.85	dB
Digital Gain Resolution				6		dB
Analog Gain			-28		3	dB
Analog Gain step				1		dB
Output resistance	$R_L$		8	16		Ohm
Output capacitance	$C_p$				500	pF
Crosstalk between channels	L vs. R, measured at -10dBFS@1KHz input			-90	-80	dB
Analog supply voltage (AVDD)			1.8	2.8	3.0	V

### Battery Charger

Charging Mode (BAT_IN rising to 4.2V)		Min	Typ	Max	Unit
Operation Temperature		-20		70	°C
Input Voltage (Vin) Note: It needs more time to get battery fully charged when Vin=4.5V		4.5		6	V
Battery trickle charge current (BAT_IN < trickle charge voltage threshold)			0.1C		mA
Trickle charge voltage threshold			3		V
Maximum battery charge current	Headroom > 0.7V		350		mA
	Headroom = 0.3V		150		mA
Minimum battery charge current	Headroom > 0.7V		1		mA
	Headroom = 0.3V		1		mA
Battery charge termination current, % of fast charge current			10		%
Battery recharge hysteresis (Note1)			100		mV
Battery recharge current (Note2) Note: C → Battery capacity			0.25C		mA

Note1 : When charging complete and the adapter is still in, the battery voltage will slowly drop down.

When the voltage drop is larger than 100mV from the full voltage, the re-charging cycle will start.

Note2 : If the battery voltage during plug in is larger than 4V, the charging current will be limited to 0.25C to avoid the battery voltage overshoot.

### Switching Regulator

Normal Operation		Min	Typ	Max	Unit
Operation Temperature		-20		70	°C
Input Voltage (Vin)		3	3.7	4.5	V
Output Voltage (Vout)		1.6	1.85	2.4	mA
Output Ripple				20	mVrms
Max. Average Load Current(Iload)		120			mA
Max. Output Current (peak)		200			mA
Conversion Efficiency (Bat.@3.7V)	Iload =50mA		88		%
	Iload ≥ 10mA		80		
	Iload ≥ 250uA		65		
Switching Frequency			800		KHz
Start-up current Limit		0	50	210	mA
Start-up Settling Time			1.2	2	ms
Shutdown Current				<1	uA

### LDO

Normal Operation		Min	Typ	Max	Unit
Input Voltage ( $V_{in}$ )		3.0		4.5	V
Output Voltage ( $V_{OUT}$ ) (1) $V_{OUT\_CODEC}$ (2) $V_{OUT\_IO}$	$V_{OUT} = 2.9V (2.4\sim 3.4V)$		2.9		V
	$V_{OUT} = 1.8V (1.3\sim 2.3V)$		1.8		
Accuracy ( $V_{IN}=3.7V, I_{LOAD}=100mA, 27^{\circ}C$ )			$\pm 5$		%
Output Voltage adjustable step			100		mV/Step
Output adjustment range			$\pm 0.5$		V
Start-up inrush current			200	400	mA
Start-up Settling Time			250	500	$\mu s$
Output current(average)				100	mA
Output Current(peak)				150	mA
Drop-out voltage ( $I_{load} =$ maximum output current)				300	mV
Quiescent Current (excluding load, $I_{load} < 1mA$ )			45		$\mu A$
Load Regulation ( $I_{load} = 0mA$ to $100mA$ ), $\Delta V_{out}$				80	mV
Shutdown Current				<1	$\mu A$

Note: Two 100mA LDOs, one for IO and one for audio CODEC.

### Clock

Parameters	MIN	TYP	MAX	Unit
Crystal Frequency		16		MHz
Frequency Tolerance		±20		ppm
Operating Temperature	-20		70	°C
Trimming Capacitance		6.4		pF
Trimming Step Size		0.2		pF

### Digital GPIO (2.8V)

Parameters	MIN	TYP	MAX	Unit
<b>Input Voltage</b>	2.7	3	3.6	V
V <sub>IH</sub> (Input High Voltage)	2.0		V <sub>DD</sub>	V
V <sub>IL</sub> (Input Low Voltage)	0		0.8	V
<b>Input Reference Resistor</b>				
R <sub>PU</sub> (Pull-Up Resistor)		50K		Ohm
R <sub>PD</sub> (Pull-Down Resistor)		50K		Ohm
<b>Output Voltage</b>				
V <sub>OH</sub> (Output High Voltage)	2.4		V <sub>DD</sub>	V
V <sub>OL</sub> (Output Low Voltage)	0		0.4	V

## 8 Package Information

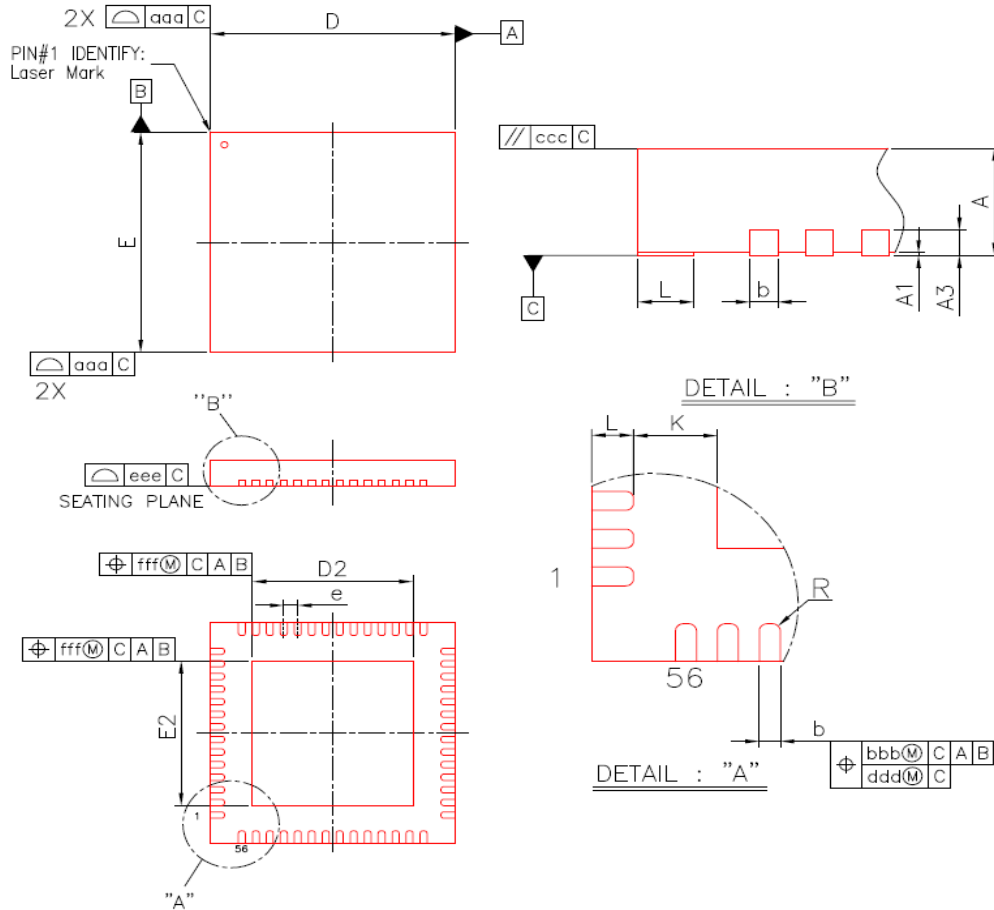

Symbol	Dimension in mm			Dimension in Inch		
	MIN	NOM	MAX	MIN	NOM	MAX
A	0.80	0.85	0.90	0.031	0.033	0.035
A1	0.00	0.02	0.05	0.000	0.001	0.002
A3	0.20 REF			0.008 REF		
b	0.15	0.20	0.25	0.006	0.008	0.010
D	6.90	7.00	7.10	0.272	0.276	0.280
E	6.90	7.00	7.10	0.272	0.276	0.280
D2	4.45	4.60	4.75	0.175	0.181	0.187
E2	4.45	4.60	4.75	0.175	0.181	0.187
e	0.40 BSC			0.016 BSC		
L	0.30	0.40	0.50	0.012	0.016	0.020
K	0.20	---	---	0.008	---	---
R	0.075	---	---	0.003	---	---
aaa	0.10			0.004		
bbb	0.07			0.003		
ccc	0.10			0.004		
ddd	0.05			0.002		
eee	0.08			0.003		
fff	0.10			0.004		

NOTE:

1. CONTROLLING DIMENSION : MILLIMETER
2. REFERENCE DOCUMENT: JEDEC MO-220.

## Appendix A. Reflow Profile

1.) Follow: IPC/JEDEC J-STD-020 C

2.) Condition:

Average ramp-up rate (217°C to peak): 1~2°C/sec max.

Preheat : 150~200°C · 60~180 seconds

Temperature maintained above 217°C : 60~150 seconds

Time within 5°C of actual peak temperature: 20 ~ 40 sec.

Peak temperature : 250+0/-5°C or 260+0/-5°C

Ramp-down rate : 3°C/sec. max.

Time 25°C to peak temperature : 8 minutes max.

Cycle interval : 5 minus

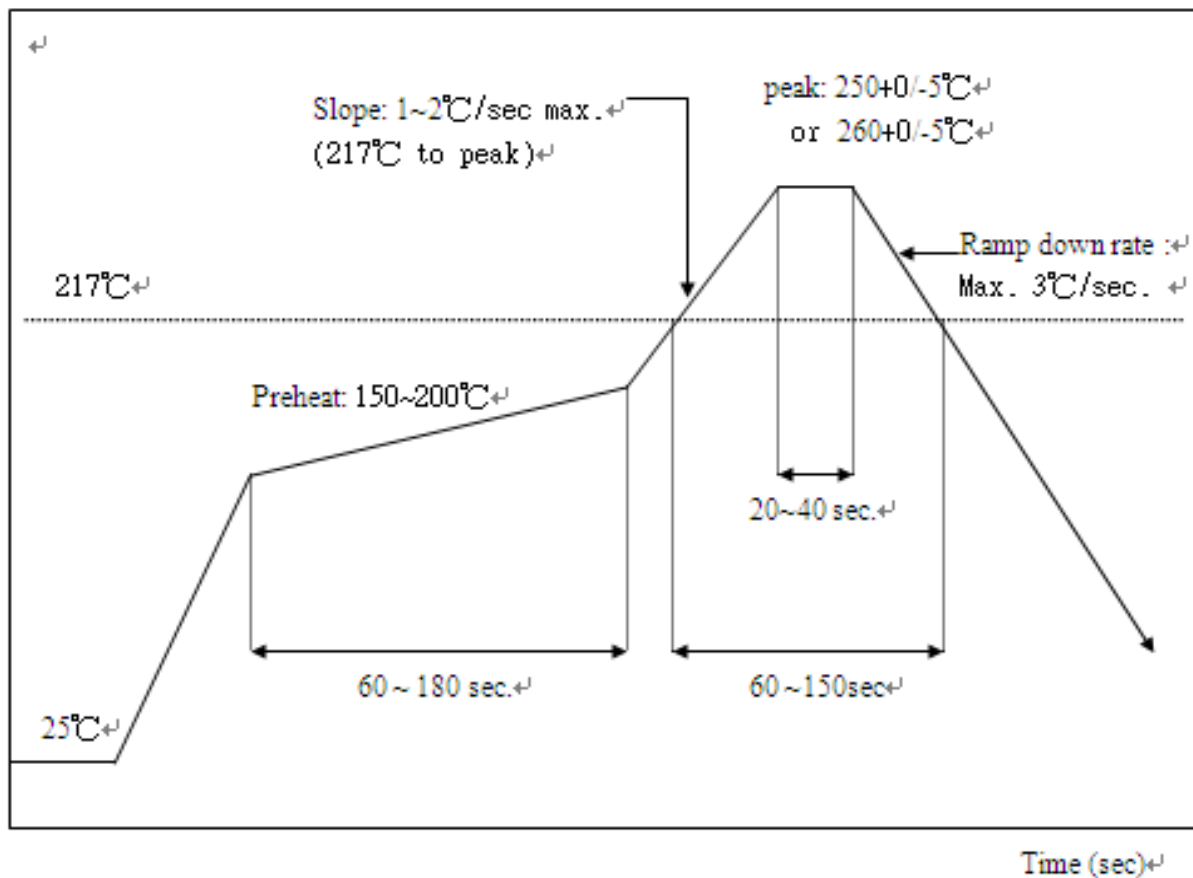

## Appendix B. BQB certification

<b>TPG Project</b>	ISSC Bluetooth 3.0(EDR) Single Chip (Component (Tested))			
<b>Qualified Design ID (QD ID)</b>	B016749   <a href="#">Export PICS</a>			
<b>PRD 1.0 ID (QP ID)</b>				
<b>Design Name</b>	ISSC Bluetooth 3.0(EDR) Single Chip			
<b>Wi-Fi® Certification ID</b>				
<b>Subsetted Designs</b>	<b>Date Created</b>	<b>Type</b>	<b>PICS</b>	
	Jun 28, 2010	Main	<a href="#">PICS</a>	
<b>Member Company</b>	ISSC Technologies Corp.			
<b>Specification Name</b>	3.0			
<b>Core Spec Addenda</b>	N/A			
<b>Design Model Number</b>	IS1XYZ, where X, Y and Z means 1~9			
<b>Hardware Version Number</b>	ISBT_BB_v30			
<b>Software Version Number</b>	ISBT_BB_v30			
<b>Qualification Assessment Date</b>	July/21/2010			
<b>Listing Date</b>	July/21/2010			
<b>Design Description</b>	ISSC Bluetooth 3.0(EDR) Single Chip			
<b>Product Type</b>	Component (Tested)			
<b>Technical Data Sheet (RIN)</b>	<b>** <a href="#">Open Reference Integration Notes (RIN)</a> **</b>			
<b>Listed By</b>	<a href="#">Charlie Lee</a>			
<b>BQE</b>	<a href="#">Jan-Willem Vonk</a>			
<b>Profile / Protocol</b>	<b>Role / Version (If Any)</b>			
Baseband				
Radio				
Link Manager				