

FCC PART 22/24 TEST REPORT

FCC Part 22 /Part 24

Report Reference No...... : **MWR150900701**

FCC ID..... : **RQQHLT-L50SPM**

Compiled by
(position+printed name+signature)..: File administrators Martin Ao



Supervised by
(position+printed name+signature)..: Test Engineer Yuchao Wang



Approved by
(position+printed name+signature)..: Manager Dixon Hao

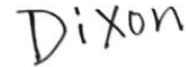

Date of issue.....: Sep 24, 2015

Representative Laboratory Name ..: **Maxwell International Co., Ltd.**

Address.....: Room 509, Hongfa center building, Baoan District, Shenzhen, Guangdong, China

Testing Laboratory Name: **CCIC Southern Electronic Product Testing (Shenzhen) Co., Ltd.**

Address.....: Electronic Testing Building, Shahe Road, Xili, Nanshan District, Shenzhen, 518055, P. R. China

Applicant's name.....: **HYUNDAI CORPORATION**

Address.....: 140-2, Kye-dong, Chongro-ku, Seoul, South Korea

Test specification :

Standard: **FCC Part 22: PUBLIC MOBILE SERVICES**

FCC Part 24: PERSONAL COMMUNICATIONS SERVICES

TRF Originator.....: Maxwell International Co., Ltd.

Maxwell International Co., Ltd. All rights reserved.

This publication may be reproduced in whole or in part for non-commercial purposes as long as the Maxwell International Co., Ltd. as copyright owner and source of the material. Maxwell International Co., Ltd. takes no responsibility for and will not assume liability for damages resulting from the reader's interpretation of the reproduced material due to its placement and context.

Test item description: Mobile Phone

Trade Mark: HYUNDAI

Manufacturer.....: **Sprocomm Technologies CO.,Ltd.**

Model/Type reference.....: L565

Listed Models: N/A

Ratings.....: DC 3.80V

Modulation: GMSK, 8-PSK

GPRS.....: Supported

EGPRS: Supported

Hardware version: FA1611 Ver.B

Software version: HYUNDAI_L565_V4.0.3

Frequency.....: GSM 850MHz; PCS 1900MHz;

Result.....: **PASS**

TEST REPORT

Test Report No. :	MWR150900701	Sep. 24, 2015
		Date of issue

Equipment under Test : Mobile Phone

Model /Type : L565

Listed Models : N/A

Applicant : **HYUNDAI CORPORATION**

Address : 140-2, Kye-dong, Chongro-ku, Seoul, South Korea

Manufacturer : **Sprocomm Technologies CO.,Ltd.**

Address : 5D-506 F1.6 Block, Tianfa Building, Tianan Chegongmiao Industrial Park, Futian Dist, Shenzhen, China

Test Result:	PASS
---------------------	-------------

The test report merely corresponds to the test sample.

It is not permitted to copy extracts of these test result without the written permission of the test laboratory.

Contents

<u>1</u>	<u>TEST STANDARDS.....</u>	<u>4</u>
<u>2</u>	<u>SUMMARY</u>	<u>5</u>
2.1	General Remarks	5
2.2	Product Description	5
2.3	Equipment under Test	6
2.4	Short description of the Equipment under Test (EUT)	6
2.5	Internal Identification of AE used during the test	6
2.6	Normal Accessory setting	6
2.7	EUT configuration	7
2.8	Related Submittal(s) / Grant (s)	7
2.9	Modifications	7
2.10	General Test Conditions/Configurations	7
<u>3</u>	<u>TEST ENVIRONMENT.....</u>	<u>8</u>
3.1	Address of the test laboratory	8
3.2	Test Facility	8
3.3	Environmental conditions	8
3.4	Test Description	8
3.5	Equipments Used during the Test	9
<u>4</u>	<u>TEST CONDITIONS AND RESULTS.....</u>	<u>10</u>
4.1	Output Power	10
4.2	Radiated Spurious Emission	15
4.3	Occupied Bandwidth and Emission Bandwidth	19
4.4	Band Edge Complicance	25
4.5	Spurious Emission on Antenna Port	30
4.6	Frequency Stability Test	47
4.7	Peak-to-Average Ratio (PAR)	50
<u>5</u>	<u>TEST SETUP PHOTOS OF THE EUT</u>	<u>51</u>
<u>6</u>	<u>EXTERNAL PHOTOS OF THE EUT.....</u>	<u>51</u>
<u>7</u>	<u>INTERNAL PHOTOS OF THE EUT.....</u>	<u>51</u>

1 TEST STANDARDS

The tests were performed according to following standards:

[FCC Part 22 \(10-1-12 Edition\)](#): PRIVATE LAND MOBILE RADIO SERVICES.

[FCC Part 24\(10-1-12 Edition\)](#): PUBLIC MOBILE SERVICES

[TIA/EIA 603 D June 2010](#): Land Mobile FM or PM Communications Equipment Measurement and Performance Standards.

[47 CFR FCC Part 15 Subpart B](#): - Unintentional Radiators

[FCC Part 2](#): FREQUENCY ALLOCA-TIONS AND RADIO TREATY MAT-TERS; GENERAL RULES AND REG-ULATIONS

[ANSI C63.4:2009](#): Methods of Measurement of Radio-Noise Emissions from Low-Voltage Electrical and Electronic Equipment in the Range of 9 kHz to 40 GHz

2 SUMMARY

2.1 General Remarks

Date of receipt of test sample	:	Aug 27, 2015
Testing commenced on	:	Aug 28, 2015
Testing concluded on	:	Sep 24, 2015

2.2 Product Description

The **HYUNDAI CORPORATION**'s Model: L565 or the "EUT" as referred to in this report; more general information as follows, for more details, refer to the user's manual of the EUT.

Name of EUT	Mobile Phone
Model Number	L565
Modulation Type	GMSK for GSM/GPRS, 8-PSK for EDGE, QPSK for UMTS, QPSK, 16QAM for LTE
Antenna Type	Internal
UMTS Operation Frequency Band	Device supported UMTS FDD Band II/IV/V
WLAN FCC Operation frequency	IEEE 802.11b:2412-2462MHz IEEE 802.11g:2412-2462MHz IEEE 802.11n HT20:2412-2462MHz IEEE 802.11n HT40:2422-2452MHz
BT FCC Operation frequency	2402MHz-2480MHz
HSDPA Release Version	Release 10
HSUPA Release Version	Release 6
DC-HSUPA Release Version	Not Supported
WCDMA Release Version	R99
LTE Release Version	R8
UMTS Operation Frequency Band	Device supported FDD band 2, FDD band 4, FDD band 7, FDD band 17
WLAN FCC Modulation Type	IEEE 802.11b: DSSS(CCK,DQPSK,DBPSK) IEEE 802.11g: OFDM(64QAM, 16QAM, QPSK, BPSK) IEEE 802.11n HT20: OFDM (64QAM, 16QAM, QPSK,BPSK) IEEE 802.11n HT40: OFDM (64QAM, 16QAM, QPSK,BPSK)
BT Modulation Type	GFSK,8DPSK, π /4DQPSK(BT 3.0+EDR)
Hardware version	FA1611 Ver.B
Software version	HYUNDAI_L565_V4.0.3
Android version	Android 4.4.2
GPS function	Supported
WLAN	Supported 802.11b/802.11g/802.11n
Bluetooth	Supported BT 4.0/BT 3.0+EDR
GSM/EDGE/GPRS	Supported GSM/GPRS/EDGE
GSM/EDGE/GPRS Power Class	GSM850:Power Class 4/ PCS1900:Power Class 1
GSM/EDGE/GPRS Operation Frequency	GSM850 :824.2MHz-848.8MHz/PCS1900:1850.2MHz-1909.8MHz
GSM/EDGE/GPRS Operation Frequency Band	GSM850/PCS1900/GPRS850/GPRS1900/EDGE850/EDGE1900
GSM Release Version	R99
GPRS/EDGE Multislot Class	GPRS/EDGE: Multi-slot Class 12
Extreme temp. Tolerance	-30°C to +50°C
Extreme vol. Limits	3.40VDC to 4.20VDC (nominal: 3.80VDC)
GPRS operation mode	Class B

2.3 Equipment under Test

Power supply system utilised

Power supply voltage	:	<input type="radio"/> 120V / 60 Hz	<input type="radio"/> 115V / 60Hz
		<input type="radio"/> 12 V DC	<input type="radio"/> 24 V DC
		<input checked="" type="radio"/> Other (specified in blank below)	

DC 3.80V

Test frequency list

Test Mode	TX/RX	RF Channel		
		Low(L)	Middle (M)	High (H)
GSM850	TX	Channel 128	Channel 190	Channel 251
		824.2 MHz	836.6 MHz	848.8 MHz
	RX	Channel 128	Channel 190	Channel 251
		869.2 MHz	881.6 MHz	893.8 MHz
Test Mode	TX/RX	RF Channel		
		Low(L)	Middle (M)	High (H)
GSM1900	TX	Channel 512	Channel 661	Channel 810
		1850.2 MHz	1880.0 MHz	1909.8 MHz
	RX	Channel 512	Channel 661	Channel 810
		1930.2 MHz	1960.0 MHz	1989.8 MHz

2.4 Short description of the Equipment under Test (EUT)

2.4.1 General Description

L565 is subscriber equipment in the WCDMA/GSM /LTE system. The HSPA/UMTS frequency band is Band II, Band IV and Band V, LTE frequency band is band 2,band 4, band 7,band 17; The GSM/GPRS/EDGE frequency band includes GSM850 and GSM900 and DCS1800 and PCS1900, but only Band II and Band V and GSM850 and PCS1900 bands test data included in this report. The Mobile Phone implements such functions as RF signal receiving/transmitting, HSPA/UMTS ,LTE and GSM/GPRS/EDGE protocol processing, voice, video MMS service, GPS and WIFI etc. Externally it provides micro SD card interface, earphone port (to provide voice service) and SIM card interface. It also provides Bluetooth module to synchronize data between a PC and the phone, or to use the built-in modem of the phone to access the Internet with a PC, or to exchange data with other Bluetooth devices.

NOTE: Unless otherwise noted in the report, the functional boards installed in the units shall be selected from the below list, but not means all the functional boards listed below shall be installed in one unit.

2.5 Internal Identification of AE used during the test

AE ID*	Description
AE1	Charger

AE1
 Model: L565
 INPUT: AC100-240V 50/60Hz 0.3A Max
 OUTPUT: DC 5.0V 1.0A

*AE ID: is used to identify the test sample in the lab internally.

2.6 Normal Accessory setting

Fully charged battery was used during the test.

2.7 EUT configuration

The following peripheral devices and interface cables were connected during the measurement:

● - supplied by the manufacturer

○ - supplied by the lab

<input type="radio"/>	Power Cable	Length (m) :	/
		Shield :	/
		Detachable :	/
<input type="radio"/>	Multimeter	Manufacturer :	/
		Model No. :	/

2.8 Related Submittal(s) / Grant (s)

This submittal(s) (test report) is intended for **FCC ID: RQQLT-L50SPM** filing to comply with FCC Part 22 and Part 24 Rules

2.9 Modifications

No modifications were implemented to meet testing criteria.

2.10 General Test Conditions/Configurations

2.10.1 Test Modes

NOTE: The test mode(s) are selected according to relevant radio technology specifications.

Test Mode	Test Modes Description
GSM/TM1	GSM system, GSM, GMSK modulation
GSM/TM2	GSM system, GPRS, GMSK modulation
GSM/TM3	GSM system, EDGE, 8PSK modulation

Note:

1. This EUT owns two SIM cards, after we perform the pretest for these two SIM cards; we found the SIM 1 is the worst case, so its result is recorded in this report.
2. As GSM and GPRS with the same emission designator, test result recorded in this report at the worst case GSM/TM1 only after exploratory scan.

2.10.2 Test Environment

Environment Parameter	Selected Values During Tests	
Relative Humidity	Ambient	
Temperature	TN	Ambient
Voltage	VL	3.4V
	VN	3.8V
	VH	4.2V

NOTE: VL=lower extreme test voltage VN=nominal voltage
VH=upper extreme test voltage TN=normal temperature

3 TEST ENVIRONMENT

3.1 Address of the test laboratory

CCIC Southern Electronic Product Testing (Shenzhen) Co., Ltd.

Electronic Testing Building, Shahe Road, Xili, Nanshan District, Shenzhen, 518055, P. R. China
The sites are constructed in conformance with the requirements of ANSI C63.7, ANSI C63.4 (2003) and CISPR Publication 22.

3.2 Test Facility

The test facility is recognized, certified, or accredited by the following organizations:

FCC-Registration information:

FCC-Registration No.: 406086

CCIC Southern Electronic Product Testing (Shenzhen) Co., Ltd. EMC Laboratory has been registered and fully described in a report filed with the FCC (Federal Communications Commission). The acceptance letter from the FCC is maintained in our files. Registration 406086, valid time is until October 28, 2017.

3.3 Environmental conditions

During the measurement the environmental conditions were within the listed ranges:

Temperature:	15-35 ° C
Humidity:	30-60 %
Atmospheric pressure:	950-1050mbar

3.4 Test Description

3.4.1 Cellular Band (824-849MHz paired with 869-894MHz)

Test Item	FCC Rule No.	Requirements	Verdict
Effective(Isotropic) Radiated Output Power	§2.1046, §22.913	FCC: ERP ≤ 7W.	Pass
Modulation Characteristics	§2.1047	Digital modulation	N/A
Bandwidth	§2.1049	OBW: No limit. EBW: No limit.	Pass
Band Edges Compliance	§2.1051, §22.917	≤-13dBm/1%*EBW, in 1MHz bands immediately outside and adjacent to The frequency block.	Pass
Spurious Emission at Antenna Terminals	§2.1051, §22.917	FCC: ≤ -13dBm/100kHz, from 9kHz to 10th harmonics but outside authorized operating frequency ranges.	Pass
Field Strength of Spurious Radiation	§2.1053, §22.917	FCC: ≤ -13dBm/100kHz.	Pass
Frequency Stability	§2.1055, §22.355	≤ ±2.5ppm.	Pass

NOTE 1: For the verdict, the "N/A" denotes "not applicable", the "N/T" denotes "not tested".

3.4.2 PCS Band (1850-1915MHz paired with 1930-1995MHz)

Test Item	FCC Rule No.	Requirements	Verdict
Effective(Isotropic) Radiated Output Power	§2.1046, §24.232	EIRP \leq 2W	Pass
Peak-Average Ratio	§2.1046, §24.232	FCC:Limits \leq 13dB	Pass
Modulation Characteristics	§2.1047	Digital modulation	N/A
Bandwidth	§2.1049	OBW: No limit. EBW: No limit.	Pass
Band Edges Compliance	§2.1051, §24.238	\leq -13dBm/1%*EBW, In 1MHz bands immediately outside and adjacent to The frequency block.	Pass
Spurious Emission at Antenna Terminals	§2.1051, §24.238	\leq -13dBm/1MHz, from 9kHz to10th harmonics but outside authorized Operating frequency ranges.	Pass
Field Strength of Spurious Radiation	§2.1053, §24.238	\leq -13dBm/1MHz.	Pass
Frequency Stability	§2.1055, §24.235	FCC: within authorized frequency block.	Pass

NOTE 1: For the verdict, the "N/A" denotes "not applicable", the "N/T" de notes "not tested".

Remark:

1. The measurement uncertainty is not included in the test result.

3.5 Equipments Used during the Test

Description	Manufacturer	Model	Serial No.	Test Date	Due Date
EMI Test Receiver	R&S	ESIB26	A0304218	2015.06.02	2016.06.01
Full-Anechoic Chamber	Albatross	12.8m*6.8m *6.4m	A0412372	2015.01.05	2016.01.04
Loop Antenna	Schwarz beck	HFH2-Z2	100047	2015.06.02	2016.06.01
Bilog Antenna	Schwarzbeck	VULB 9163	9163-274	2015.06.02	2016.06.01
Bilog Antenna	Schwarzbeck	VULB 9163	9163-276	2015.06.02	2016.06.01
Double ridge horn antenna	R&S	HF906	100150	2015.06.02	2016.06.01
Double ridge horn antenna	R&S	HF906	100155	2015.06.02	2016.06.01
Ultra-wideband antenna	R&S	HL562	100089	2015.06.02	2016.06.01
Ultra-wideband antenna	R&S	HL562	100090	2015.06.02	2016.06.01
Test Antenna – Horn (18-25GHz)	ETS	UG-596A/U	A0902607	2015.06.02	2016.06.01
Test Antenna – Horn (18-25GHz)	ETS	UG-596A/U	A0902611	2015.06.02	2016.06.01
Amplifier 20M~3GHz	R&S	PAP-0203H	22018	2015.06.02	2016.06.01
Ampilier 1G~18GHz	R&S	MITEQ AFS42- 00101800	25-S-42	2015.06.02	2016.06.01
Ampilier 18G~40GHz	R&S	JS42- 18002600- 28-5A	12111.0980. 00	2015.06.02	2016.06.01
System Simulator	R&S	CMW500	A130101034	2015.06.010	2016.06.09
Signal Generator	R&S	SMF100A	A0304267	2015.06.010	2016.06.09
Signal Analyzer	Agilent	N9030A	MY49430428	2015.06.010	2016.06.09

The calibration interval was one year.

4 TEST CONDITIONS AND RESULTS

4.1 Output Power

TEST APPLICABLE

During the process of testing, the EUT was controlled via R&S Digital Radio Communication tester (CMW500) to ensure max power transmission and proper modulation. This result contains output power and EIRP measurements for the EUT. In all cases, output power is within the specified limits.

4.1.1 Conducted Output Power

TEST CONFIGURATION

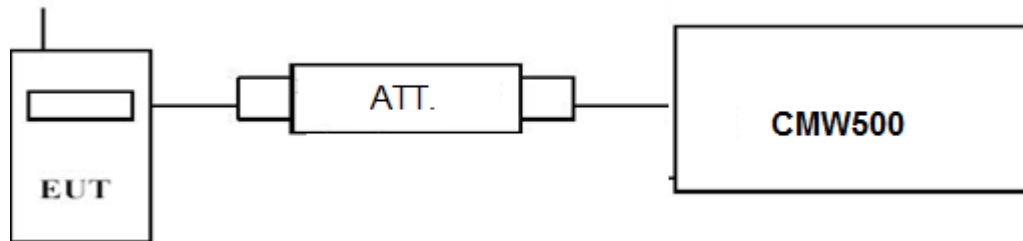

TEST PROCEDURE

Conducted Power Measurement:

- Place the EUT on a bench and set it in transmitting mode.
- Connect a low loss RF cable from the antenna port to a CMW500 by an Att.
- EUT Communicate with CMW500 then selects a channel for testing.
- Add a correction factor to the display CMW500, and then test.

GSM850				
Function	Power step	Nominal output power (dBm)	Power & Multislot class	Operation class
GSM	5	33dBm(2W)	4	/
GPRS	3	33dBm(2W)	12	B
EDGE	8	27dBm(0.5W)	12	B

PCS1900				
Function	Power step	Nominal output power (dBm)	Power & Multislot class	Operation class
GSM	0	30dBm(1W)	1	/
GPRS	3	30dBm(1W)	12	B
EDGE	2	27dBm(0.5W)	12	B

TEST RESULTS

GSM 850		Burst Average Conducted power (dBm)		
		Channel/Frequency(MHz)		
		128/824.2	190/836.6	251/848.8
GSM		32.84	33.27	33.09
GPRS (GMSK)	1TX slot	32.84	33.27	33.09
	2TX slot	30.32	30.64	30.73
	3TX slot	28.20	28.42	28.64
	4TX slot	27.32	27.55	27.80
EGPRS (8PSK)	1TX slot	27.73	27.61	27.66
	2TX slot	25.44	25.64	25.72
	3TX slot	23.05	23.21	23.37
	4TX slot	22.23	22.51	22.63

GSM 1900		Burst Average Conducted power (dBm)		
		Channel/Frequency(MHz)		
		512/1850.2	661/1880	810/1909.8
GSM		31.05	31.04	31.26
GPRS (GMSK)	1TX slot	31.10	30.98	31.34
	2TX slot	27.62	27.54	27.82
	3TX slot	26.31	26.45	26.66
	4TX slot	25.22	25.36	25.66
EGPRS (8PSK)	1TX slot	26.13	26.05	26.54
	2TX slot	24.35	24.52	24.64
	3TX slot	23.04	23.18	23.33
	4TX slot	22.32	22.47	22.51

4.1.2 Radiated Output Power

TEST DESCRIPTION

This is the test for the maximum radiated power from the EUT.

Rule Part 24.232(c) specifies, "Mobile/portable stations are limited to 2 watts e.i.r.p. Peak power" and 24.232(e) specifies that "Peak transmit power must be measured over any interval of continuous transmission using instrumentation calibrated in terms of an rms-equivalent voltage." Rule Part 22.913(a) specifies "The ERP of mobile transmitters and auxiliary test transmitters must not exceed 7 Watts."

TEST CONFIGURATION

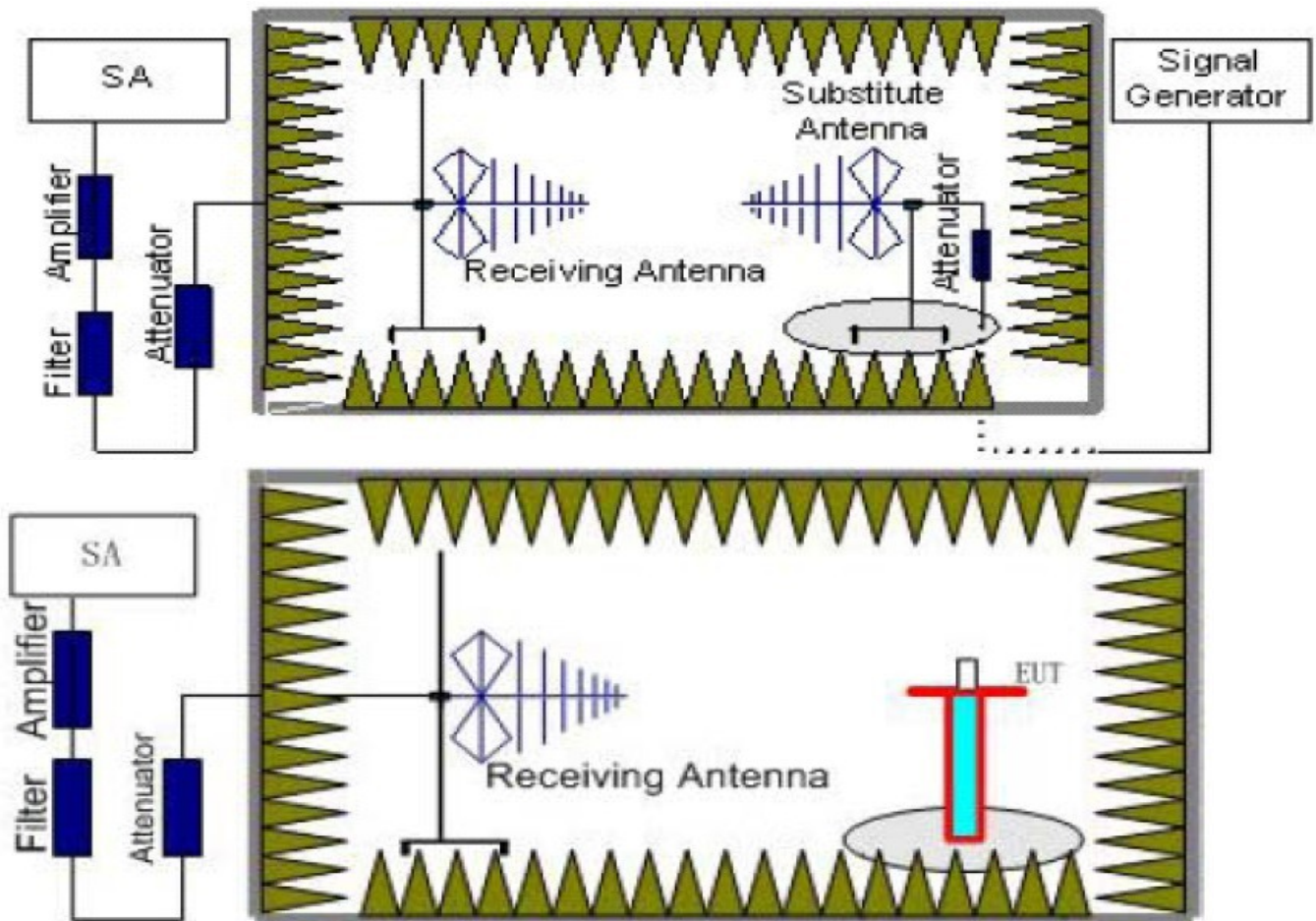

TEST PROCEDURE

1. EUT was placed on a 0.80 meter high non-conductive stand at a 3 meter test distance from the receive antenna. A receiving antenna was placed on the antenna mast 3 meters from the EUT for emission measurements. The height of receiving antenna is 0.80m. Detected emissions were maximized at each frequency by rotating the EUT through 360° and adjusting the receiving antenna polarization. The radiated emission measurements of all transmit frequencies in three channels (High, Middle, Low) were measured with peak detector.
2. A log-periodic antenna or double-ridged waveguide horn antenna shall be substituted in place of the EUT. The log-periodic antenna will be driven by a signal generator and the level will be adjusted till the same power value on the spectrum analyzer or receiver. The level of the spurious emissions can be calculated through the level of the signal generator, cable loss, the gain of the substitution antenna and the reading of the spectrum analyzer or receiver.
3. The EUT is then put into continuously transmitting mode at its maximum power level during the test. Set Test Receiver or Spectrum RBW=1MHz, VBW=3MHz, And the maximum value of the receiver should be recorded as (P_r).
4. The EUT shall be replaced by a substitution antenna. In the chamber, an substitution antenna for the frequency band of interest is placed at the reference point of the chamber. An RF Signal source for the frequency band of interest is connected to the substitution antenna with a cable that has been constructed to not interfere with the radiation pattern of the antenna. A power (P_{Mea}) is applied to the input of the

substitution antenna, and adjust the level of the signal generator output until the value of the receiver reach the previously recorded (P_r). The power of signal source (P_{Mea}) is recorded. The test should be performed by rotating the test item and adjusting the receiving antenna polarization.

5. A amplifier should be connected to the Signal Source output port. And the cable should be connect between the Amplifier and the Substitution Antenna. The cable loss (P_{cl}), the Substitution Antenna Gain (G_a) and the Amplifier Gain (P_{Ag}) should be recorded after test.

The measurement results are obtained as described below:

$$\text{Power(EIRP)} = P_{Mea} - P_{cl} + G_a$$

We used SMF100A microwave signal generator which signal level can up to 33dBm, so we not used power Amplifier for substitution test; The measurement results are amend as described below:

$$\text{Power(EIRP)} = P_{Mea} - P_{cl} + G_a$$

6. This value is EIRP since the measurement is calibrated using an antenna of known gain (2.15 dBi) and known input power.
7. ERP can be calculated from EIRP by subtracting the gain of the dipole, $ERP = EIRP - 2.15\text{dBi}$.

TEST LIMIT

Note: We test the H direction and V direction and V direction is worse.

According to 22.913(a) and 24.232(c), the ERP should be not exceed following table limits:

GSM850(GPRS850,EDGE850)		
Function	Power Step	Burst Peak ERP (dBm)
GSM	5	≤38.45dBm (7W)
GPRS	3	≤38.45dBm (7W)
EDGE	8	≤38.45dBm (7W)

PCS1900(GPRS1900,EDGE1900)		
Function	Power Step	Burst Peak EIRP (dBm)
GSM	0	≤33dBm (2W)
GPRS	3	≤33dBm (2W)
EDGE	2	≤33dBm (2W)

TEST RESULTS

Remark:

- We were tested all Configuration refer 3GPP TS151 010.
- $EIRP = P_{Mea}(\text{dBm}) - P_{cl}(\text{dB}) + P_{Ag}(\text{dB}) + G_a(\text{dBi})$
- $ERP = EIRP - 2.15\text{dBi}$ as EIRP by subtracting the gain of the dipole.

GSM/TM1/GSM850

Frequency (MHz)	P_{Mea} (dBm)	P_{cl} (dB)	G_a Antenna Gain(dB)	Correction (dB)	P_{Ag} (dB)	ERP (dBm)	Limit (dBm)	Margin (dB)	Polarization
824.20	-13.69	2.42	8.45	2.15	36.82	27.01	38.45	11.44	V
836.60	-13.11	2.46	8.45	2.15	36.82	27.55	38.45	10.90	V
848.80	-13.30	2.53	8.36	2.15	36.82	27.20	38.45	11.25	V

GSM/TM3/EDGE850

Frequency (MHz)	P_{Mea} (dBm)	P_{cl} (dB)	G_a Antenna Gain(dB)	Correction (dB)	P_{Ag} (dB)	ERP (dBm)	Limit (dBm)	Margin (dB)	Polarization
824.20	-18.29	2.42	8.45	2.15	36.82	22.41	38.45	16.04	V
836.60	-18.12	2.46	8.45	2.15	36.82	22.54	38.45	15.91	V
848.80	-18.29	2.53	8.36	2.15	36.82	22.21	38.45	16.24	V

GSM/TM1/GSM1900

Frequency (MHz)	P_{Mea} (dBm)	P_{cl} (dB)	G_a Antenna Gain(dB)	P_{Ag} (dB)	EIRP (dBm)	Limit (dBm)	Margin (dB)	Polarization
1850.20	-16.21	3.41	10.24	33.60	24.22	33.01	8.79	H
1880.00	-15.85	3.49	10.24	33.60	24.50	33.01	8.51	H
1909.80	-15.97	3.55	10.23	33.60	24.31	33.01	8.70	H

GSM/TM3/EDGE1900

Frequency (MHz)	P _{Mea} (dBm)	P _{cl} (dB)	G _a Antenna Gain(dB)	P _{Ag} (dB)	EIRP (dBm)	Limit (dBm)	Margin (dB)	Polarization
1850.20	-20.14	3.41	10.24	33.60	20.29	33.01	12.72	H
1880.00	-19.81	3.49	10.24	33.60	20.54	33.01	12.47	H
1909.80	-19.95	3.55	10.23	33.60	20.33	33.01	12.68	H

4.2 Radiated Spurious Emission

TEST APPLICABLE

According to the TIA/EIA 603D:2010 test method, The Receiver or Spectrum was scanned from 30 MHz to the 10th harmonic of the highest frequency generated within the equipment, which is the transmitted carrier that can be as high as 1910 MHz. The resolution bandwidth is set as outlined in Part 24.238 and Part 22.917. The spectrum is scanned with the mobile station transmitting at carrier frequencies that pertain to low, mid and high channels of PCS1900 and GSM850.

TEST CONFIGURATION

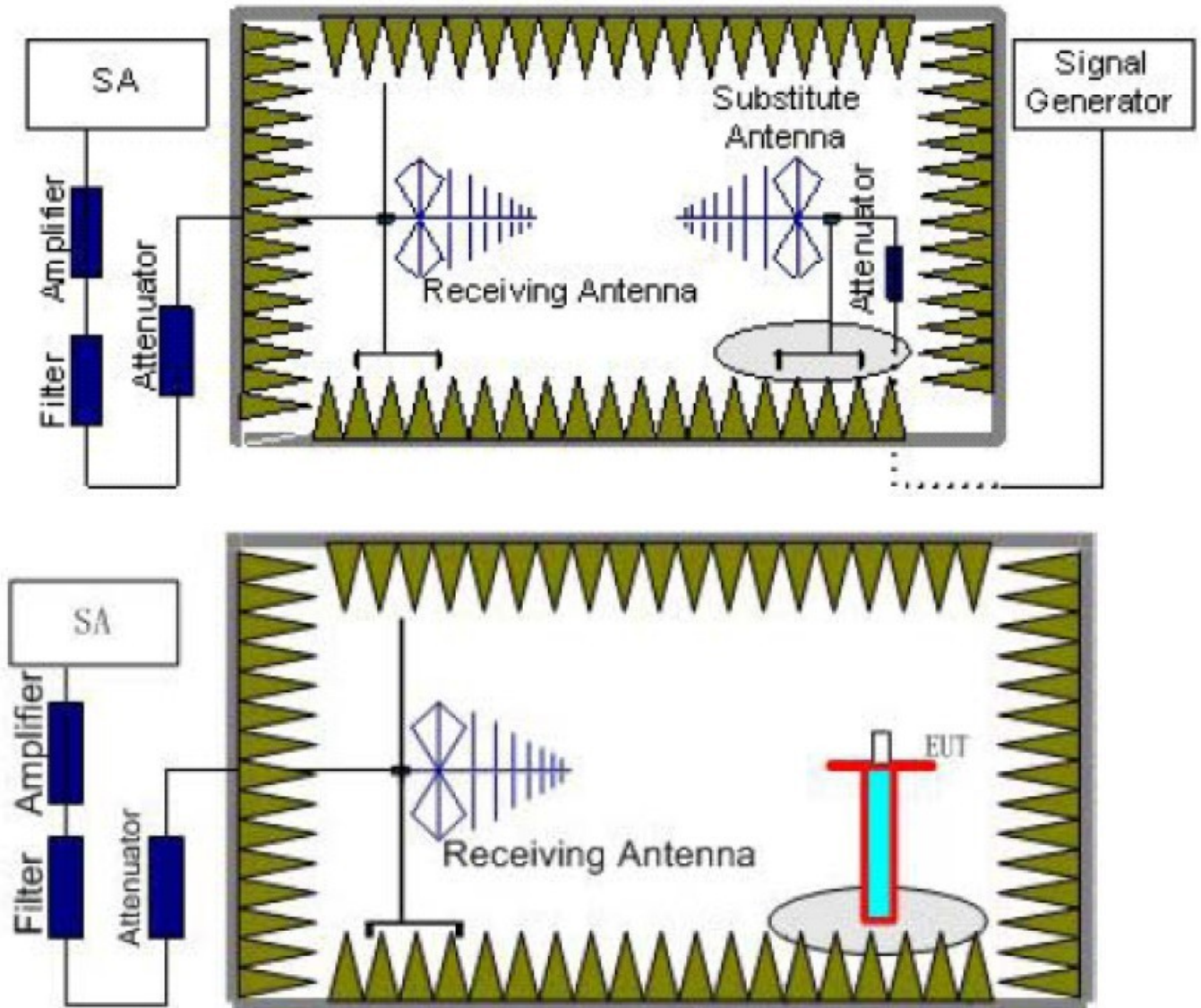

TEST PROCEDURE

1. EUT was placed on a 0.80 meter high non-conductive stand at a 3 meter test distance from the receive antenna. A receiving antenna was placed on the antenna mast 3 meters from the EUT for emission measurements. The height of receiving antenna is 0.80m. Detected emissions were maximized at each frequency by rotating the EUT through 360° and adjusting the receiving antenna polarization. The radiated emission measurements of all transmit frequencies in three channels (High, Middle, Low) were measured with peak detector.
2. A log-periodic antenna or double-ridged waveguide horn antenna shall be substituted in place of the EUT. The log-periodic antenna will be driven by a signal generator and the level will be adjusted till the same power value on the spectrum analyzer or receiver. The level of the spurious emissions can be calculated through the level of the signal generator, cable loss, the gain of the substitution antenna and the reading of the spectrum analyzer or receiver.

3. The EUT is then put into continuously transmitting mode at its maximum power level during the test. Set Test Receiver or Spectrum RBW=1MHz, VBW=3MHz, And the maximum value of the receiver should be recorded as (P_r).
4. The EUT shall be replaced by a substitution antenna. In the chamber, an substitution antenna for the frequency band of interest is placed at the reference point of the chamber. An RF Signal source for the frequency band of interest is connected to the substitution antenna with a cable that has been constructed to not interfere with the radiation pattern of the antenna. A power (P_{Mea}) is applied to the input of the substitution antenna, and adjust the level of the signal generator output until the value of the receiver reach the previously recorded (P_r). The power of signal source (P_{Mea}) is recorded. The test should be performed by rotating the test item and adjusting the receiving antenna polarization.
5. A amplifier should be connected to the Signal Source output port. And the cable should be connect between the Amplifier and the Substitution Antenna. The cable loss (P_{cl}), the Substitution Antenna Gain (G_a) and the Amplifier Gain (P_{Ag}) should be recorded after test. The measurement results are obtained as described below:
Power(EIRP)= $P_{Mea} - P_{Ag} - P_{cl} + G_a$
6. This value is EIRP since the measurement is calibrated using an antenna of known gain (2.15 dBi) and known input power.
7. ERP can be calculated from EIRP by subtracting the gain of the dipole, ERP = EIRP -2.15dBi.
8. In order to make sure test results more clearly, we set frequency range and sweep time for difference frequency range as follows table:

Working Frequency	Subrange (GHz)	RBW	VBW	Sweep time (s)
TM1/GSM 850	0.00009~0.15	1KHz	3KHz	30
	0.00015~0.03	10KHz	30KHz	10
	0.03~1	100KHz	300KHz	10
	1~2	1 MHz	3 MHz	2
	2~5	1 MHz	3 MHz	3
	5~8	1 MHz	3 MHz	3
	8~10	1 MHz	3 MHz	3
TM1/GSM 1900	0.00009~0.15	1KHz	3KHz	30
	0.00015~0.03	10KHz	30KHz	10
	0.03~1	100KHz	300KHz	10
	1~2	1 MHz	3 MHz	2
	2~5	1 MHz	3 MHz	3
	5~8	1 MHz	3 MHz	3
	8~11	1 MHz	3 MHz	3
	11~14	1 MHz	3 MHz	3
	14~18	1 MHz	3 MHz	3
18~20	1 MHz	3 MHz	2	

TEST LIMITS

According to 24.238 and 22.917 specify that the power of any emission outside of the authorized operating frequency ranges must be attenuated below the transmitting power (P) by a factor of at least $43 + 10 \log(P)$ dB.

The specification that emissions shall be attenuated below the transmitter power (P) by at least $43 + 10 \log(P)$ dB, translates in the relevant power range (1 to 0.001 W) to -13 dBm. At 1 W the specified minimum attenuation becomes 43 dB and relative to a 30 dBm (1 W) carrier becomes a limit of -13 dBm. At 0.001 W (0 dBm) the minimum attenuation is 13 dB, which again yields a limit of -13 dBm. In this way a translation of the specification from relative to absolute terms is carried out.

Frequency	Channel	Frequency Range	Verdict
TM1/GSM 850	Low	9KHz-10GHz	PASS
	Middle	9KHz -10GHz	PASS
	High	9KHz -10GHz	PASS
TM1/GSM 1900	Low	9KHz -20GHz	PASS
	Middle	9KHz -20GHz	PASS
	High	9KHz -20GHz	PASS

TEST RESULTS

Remark:

1. We were tested all refer 3GPP TS151 010.
2. $EIRP = P_{Mea}(dBm) - P_{cl}(dB) + G_a(dBi)$
3. We were not recorded other points as values lower than limits.
4. Margin = Limit - EIRP

GSM/TM1/GSM850_ Low Channel

Frequency (MHz)	P _{Mea} (dBm)	P _{cl} (dB)	Diatance	Ga Antenna Gain(dB)	Peak EIRP (dBm)	Limit (dBm)	Margin (dB)	Polarization
1648.4	-38.12	3.00	3.00	9.58	-31.54	-13.00	18.54	H
2472.6	-44.34	3.03	3.00	10.72	-36.65	-13.00	23.65	H
1648.4	-36.94	3.00	3.00	9.68	-30.26	-13.00	17.26	V
2472.6	-52.84	3.03	3.00	10.72	-45.15	-13.00	32.15	V

GSM/TM1/GSM850_ Middle Channel

Frequency (MHz)	P _{Mea} (dBm)	P _{cl} (dB)	Diatance	Ga Antenna Gain(dB)	EIRP (dBm)	Limit (dBm)	Margin (dB)	Polarization
1673.2	-36.12	3.00	3.00	9.58	-29.54	-13.00	16.54	H
2509.8	-43.56	3.03	3.00	10.72	-35.87	-13.00	22.87	H
1673.2	-39.34	3.00	3.00	9.68	-32.66	-13.00	19.66	V
2509.8	-48.47	3.03	3.00	10.72	-40.78	-13.00	27.78	V

GSM/TM1/GSM850_ High Channel

Frequency (MHz)	P _{Mea} (dBm)	P _{cl} (dB)	Diatance	Ga Antenna Gain(dB)	EIRP (dBm)	Limit (dBm)	Margin (dB)	Polarization
1697.6	-36.80	3.00	3.00	9.58	-30.22	-13.00	17.22	H
2546.4	-43.35	3.03	3.00	10.72	-35.66	-13.00	22.66	H
1697.6	-38.46	3.00	3.00	9.68	-31.78	-13.00	18.78	V
2546.4	-44.20	3.03	3.00	10.72	-36.51	-13.00	23.51	V

GSM/TM3/GSM850_ Low Channel

Frequency (MHz)	P _{Mea} (dBm)	P _{cl} (dB)	Diatance	Ga Antenna Gain(dB)	Peak EIRP (dBm)	Limit (dBm)	Margin (dB)	Polarization
1648.4	-42.06	3.00	3.00	9.58	-35.48	-13.00	22.48	H
2472.6	-48.24	3.03	3.00	10.72	-40.55	-13.00	27.55	H
1648.4	-45.34	3.00	3.00	9.68	-38.66	-13.00	25.66	V
2472.6	-50.10	3.03	3.00	10.72	-42.41	-13.00	29.41	V

GSM/TM3/GSM850_ Middle Channel

Frequency (MHz)	P _{Mea} (dBm)	P _{cl} (dB)	Diatance	Ga Antenna Gain(dB)	EIRP (dBm)	Limit (dBm)	Margin (dB)	Polarization
1673.2	-38.36	3.00	3.00	9.58	-31.78	-13.00	18.78	H
2509.8	-40.35	3.03	3.00	10.72	-32.66	-13.00	19.66	H
1673.2	-42.57	3.00	3.00	9.68	-35.89	-13.00	22.89	V
2509.8	-48.10	3.03	3.00	10.72	-40.41	-13.00	27.41	V

GSM/TM3/GSM850_ High Channel

Frequency (MHz)	P _{Mea} (dBm)	P _{cl} (dB)	Diatance	Ga Antenna Gain(dB)	EIRP (dBm)	Limit (dBm)	Margin (dB)	Polarization
1697.6	-36.72	3.00	3.00	9.58	-30.14	-13.00	17.14	H
2546.4	-43.35	3.03	3.00	10.72	-35.66	-13.00	22.66	H
1697.6	-38.26	3.00	3.00	9.68	-31.58	-13.00	18.58	V
2546.4	-47.34	3.03	3.00	10.72	-39.65	-13.00	26.65	V

GSM/TM1/GSM1900_ Low Channel

Frequency (MHz)	P _{Mea} (dBm)	Pcl (dB)	Diatance	Ga Antenna Gain(dB)	Peak EIRP (dBm)	Limit (dBm)	Margin (dB)	Polarization
3700.4	-38.09	4.39	3.00	12.34	-30.14	-13.00	17.14	H
5550.6	-43.47	5.31	3.00	13.52	-35.26	-13.00	22.26	H
3700.4	-40.82	4.39	3.00	12.34	-32.87	-13.00	19.87	V
5550.6	-46.87	5.31	3.00	13.52	-38.66	-13.00	25.66	V

GSM/TM1/GSM1900_ Middle Channel

Frequency (MHz)	P _{Mea} (dBm)	Pcl (dB)	Diatance	Ga Antenna Gain(dB)	EIRP (dBm)	Limit (dBm)	Margin (dB)	Polarization
3760.0	-38.71	4.41	3.00	12.34	-30.78	-13.00	17.78	H
5640.0	-47.75	5.38	3.00	13.58	-39.55	-13.00	26.55	H
3760.0	-43.67	4.41	3.00	12.34	-35.74	-13.00	22.74	V
5640.0	-48.42	5.38	3.00	13.58	-40.22	-13.00	27.22	V

GSM/TM1/GSM1900_ High Channel

Frequency (MHz)	P _{Mea} (dBm)	Pcl (dB)	Diatance	Ga Antenna Gain(dB)	EIRP (dBm)	Limit (dBm)	Margin (dB)	Polarization
3819.6	-43.41	4.45	3.00	12.45	-35.41	-13.00	22.41	H
5729.4	-48.93	5.47	3.00	13.66	-40.74	-13.00	27.74	H
3819.6	-44.66	4.45	3.00	12.45	-36.66	-13.00	23.66	V
5729.4	-51.05	5.48	3.00	13.66	-42.87	-13.00	29.87	V

GSM/TM3/GSM1900_ Low Channel

Frequency (MHz)	P _{Mea} (dBm)	Pcl (dB)	Diatance	Ga Antenna Gain(dB)	Peak EIRP (dBm)	Limit (dBm)	Margin (dB)	Polarization
3700.4	-41.40	4.39	3.00	12.34	-33.45	-13.00	20.45	H
5550.6	-46.98	5.31	3.00	13.52	-38.77	-13.00	25.77	H
3700.4	-46.50	4.39	3.00	12.34	-38.55	-13.00	25.55	V
5550.6	-44.75	5.31	3.00	13.52	-36.54	-13.00	23.54	V

GSM/TM3/GSM1900_ Middle Channel

Frequency (MHz)	P _{Mea} (dBm)	Pcl (dB)	Diatance	Ga Antenna Gain(dB)	EIRP (dBm)	Limit (dBm)	Margin (dB)	Polarization
3760.0	-41.40	4.41	3.00	12.34	-33.47	-13.00	20.47	H
5640.0	-48.61	5.38	3.00	13.58	-40.41	-13.00	27.41	H
3760.0	-50.80	4.41	3.00	12.34	-42.87	-13.00	29.87	V
5640.0	-53.86	5.38	3.00	13.58	-45.66	-13.00	32.66	V

GSM/TM3/GSM1900_ High Channel

Frequency (MHz)	P _{Mea} (dBm)	Pcl (dB)	Diatance	Ga Antenna Gain(dB)	EIRP (dBm)	Limit (dBm)	Margin (dB)	Polarization
3819.6	-45.84	4.45	3.00	12.45	-37.84	-13.00	24.84	H
5729.4	-47.85	5.47	3.00	13.66	-39.66	-13.00	26.66	H
3819.6	-49.41	4.45	3.00	12.45	-41.41	-13.00	28.41	V
5729.4	-47.92	5.48	3.00	13.66	-39.74	-13.00	26.74	V

4.3 Occupied Bandwidth and Emission Bandwidth

TEST APPLICABLE

Similar to conducted emissions; occupied bandwidth measurements are only provided for selected frequencies in order to reduce the amount of submitted data. Data were taken at the extreme and mid frequencies of PCS1900 band and GSM850 band. The table below lists the measured 99% Bandwidth and -26dBc Bandwidth.

TEST CONFIGURATION

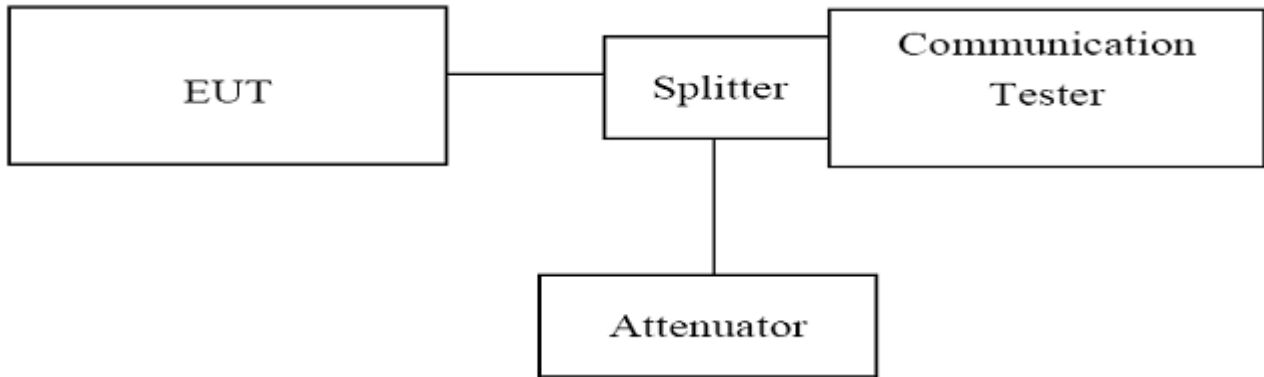

TEST PROCEDURE

1. The EUT was set up for the max output power with pseudo random data modulation;
2. The Occupied bandwidth and Emission Bandwidth were measured with Agilent Spectrum Analyzer N9030A (peak);
3. Set RBW=5.1KHz, VBW=51KHz, Span=1MHz, SWT=500ms;
4. Set SPA Max hold and View, Set 99% Occupied Bandwidth/ Set -26dBc Occupied Bandwidth
5. These measurements were done at 3 frequencies, 1850.20 MHz, 1880.00 MHz and 1909.80 MHz for PCS1900 band; 824.20MHz, 836.60 MHz and 848.80 MHz for GSM850 band. (Low, middle and high of operational frequency range).

TEST RESULTS

GSM/TM1/GSM850				
Channel Number	Frequency (MHz)	Occupied Bandwidth (99% BW) (kHz)	Emission Bandwidth (26 dBc BW) (kHz)	Verdict
128	824.20	247.41	311.28	PASS
190	836.60	245.69	312.35	PASS
251	848.80	246.49	311.25	PASS

GSM/TM3/EGPRS850				
Channel Number	Frequency (MHz)	Occupied Bandwidth (99% BW) (kHz)	Emission Bandwidth (26 dBc BW) (kHz)	Verdict
128	824.20	244.63	306.52	PASS
190	836.60	246.10	306.14	PASS
251	848.80	248.91	309.07	PASS

GSM/TM1/GSM1900				
Channel Number	Frequency (MHz)	Occupied Bandwidth (99% BW) (kHz)	Emission Bandwidth (26 dBc BW) (kHz)	Verdict
512	1850.20	245.60	311.14	PASS
661	1880.00	245.18	318.03	PASS
810	1909.80	243.04	314.01	PASS

GSM/TM3/GPRS1900				
Channel Number	Frequency (MHz)	Occupied Bandwidth (99% BW) (kHz)	Emission Bandwidth (26 dBc BW) (kHz)	Verdict
512	1850.20	246.86	309.80	PASS
661	1880.00	243.74	300.81	PASS
810	1909.80	246.03	313.49	PASS

GSM/TM1/GSM850

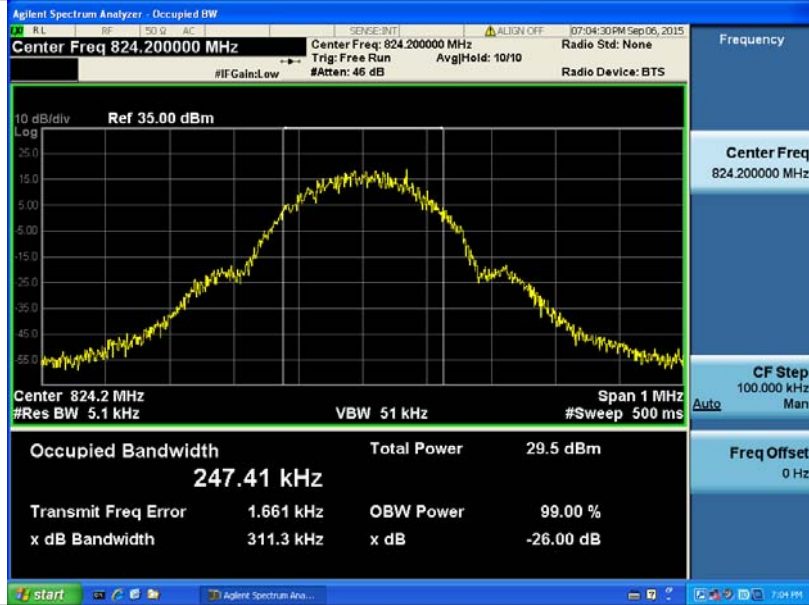

Channel 128

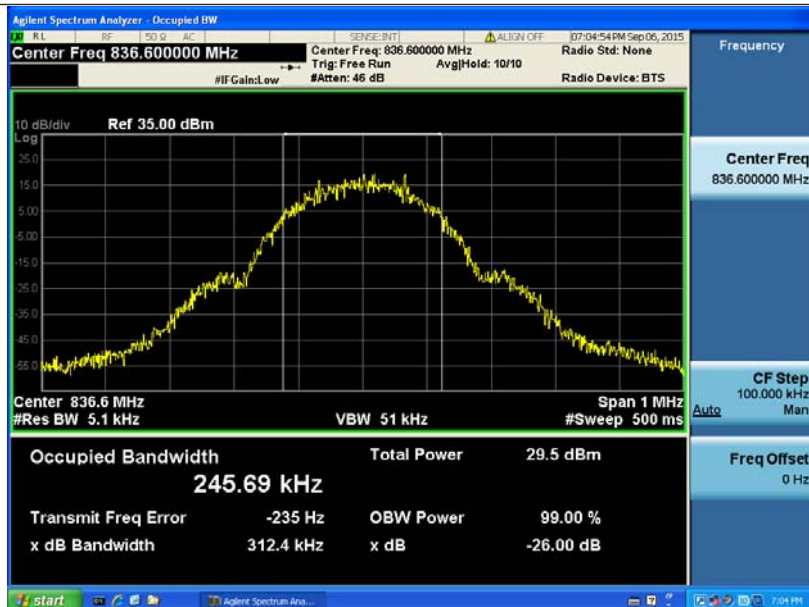

Channel 190

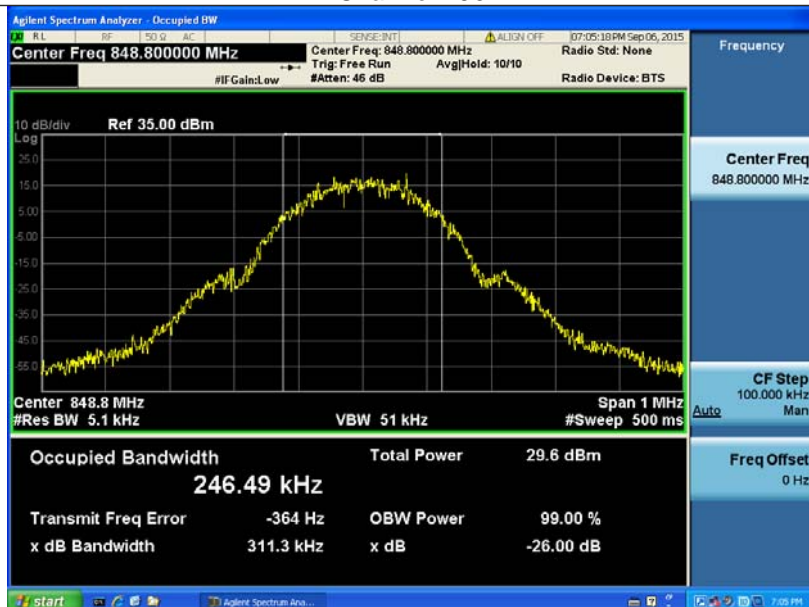

Channel 251

GSM/TM3/EGPRS850

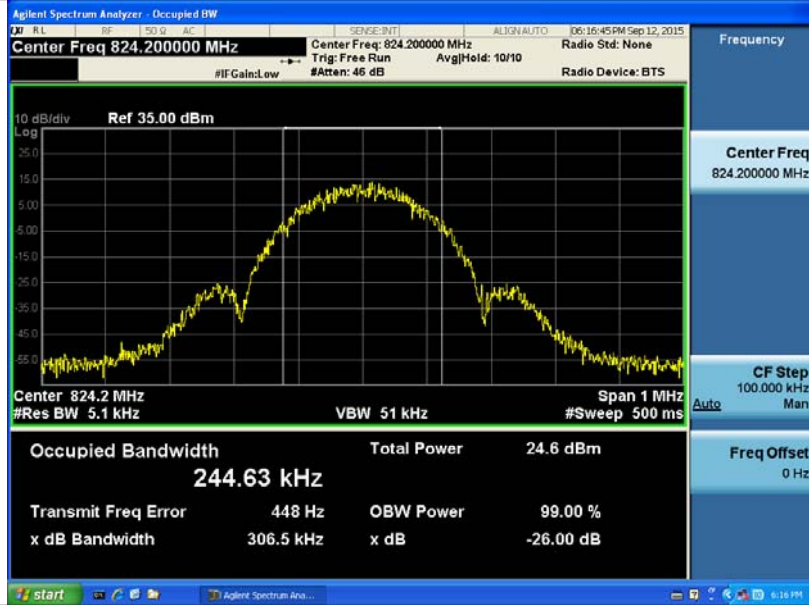

Channel 128

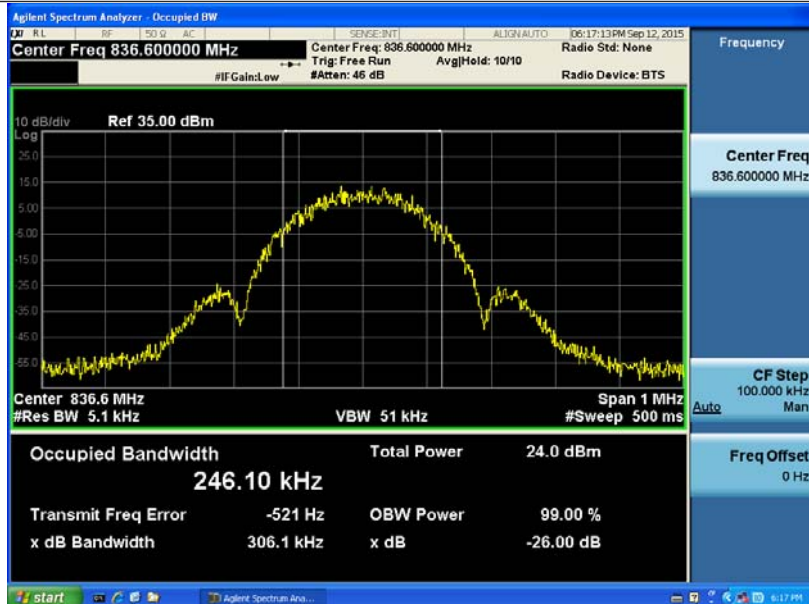

Channel 190

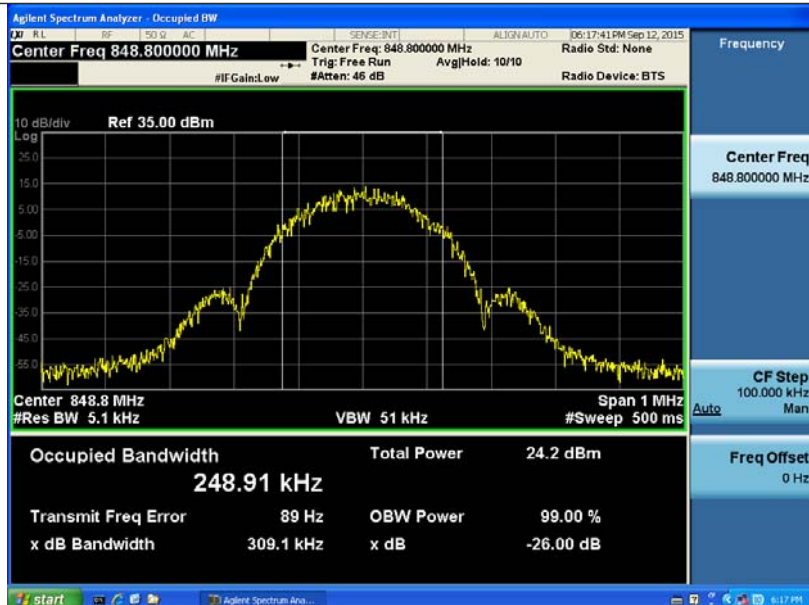

Channel 251

GSM/TM1/GSM1900

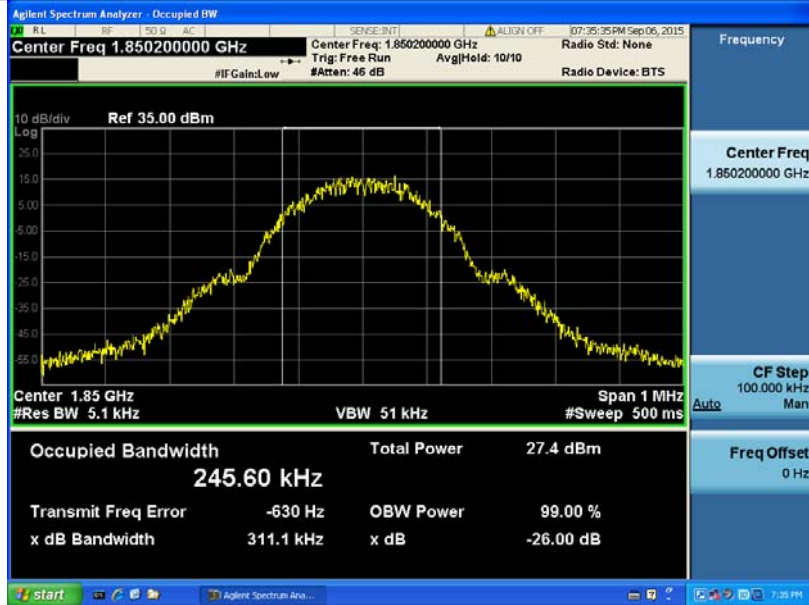

Channel 512

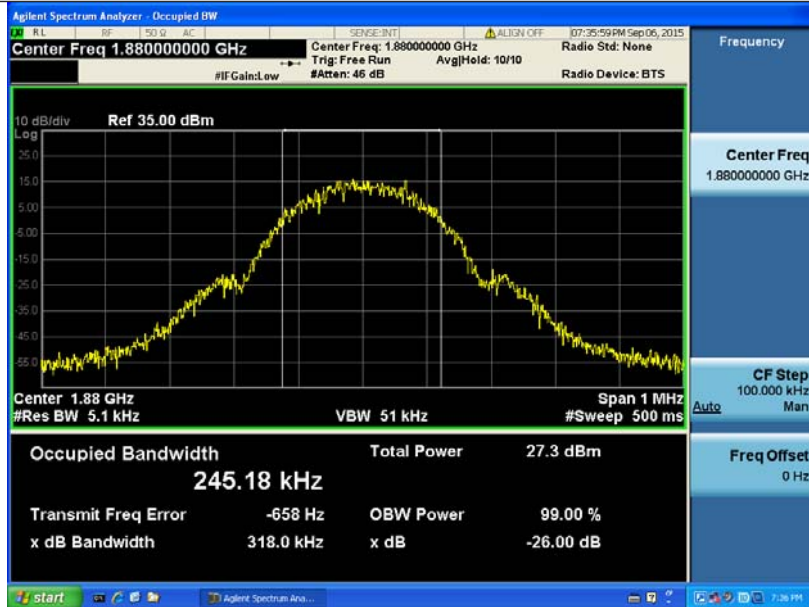

Channel 661

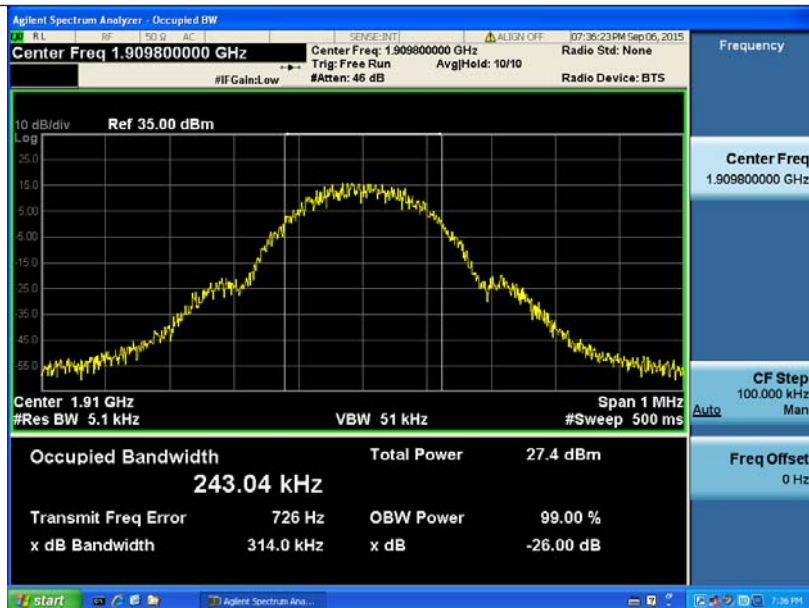

Channel 810

GSM/TM3/EGPRS1900

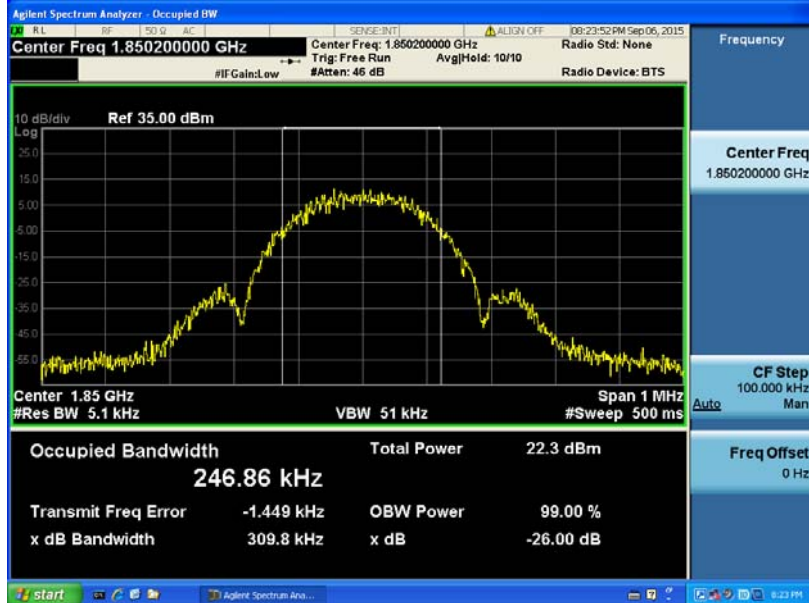

Channel 512

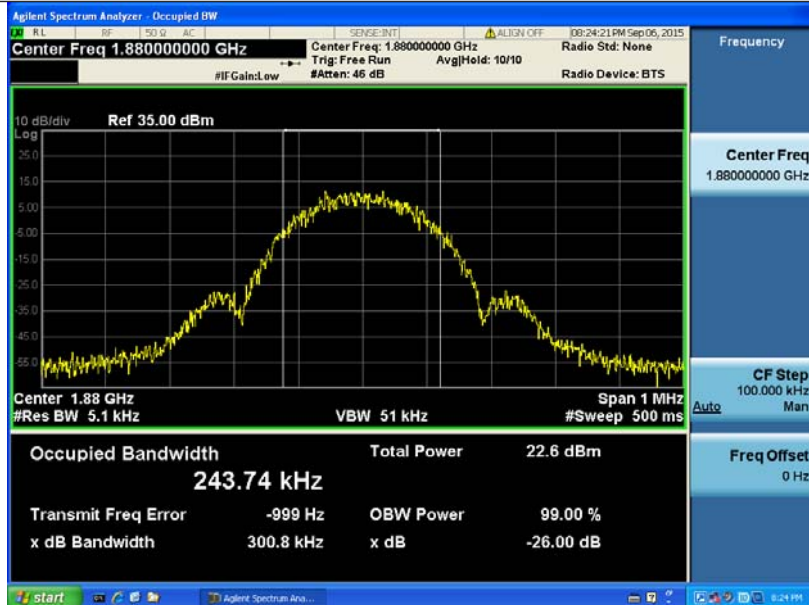

Channel 661

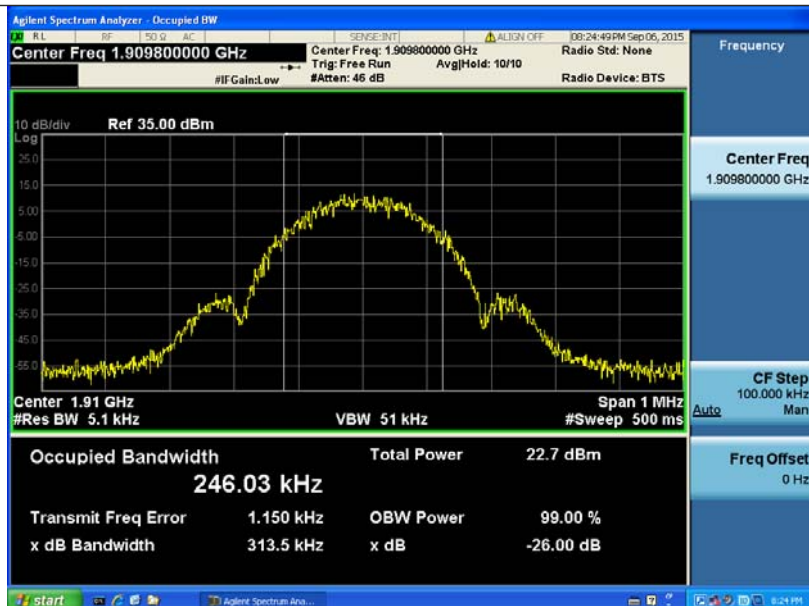

Channel 810

4.4 Band Edge Compliance

TEST APPLICABLE

During the process of testing, the EUT was controlled via Agilent Digital Radio Communication tester (CMW500) to ensure max power transmission and proper modulation.

TEST CONFIGURATION

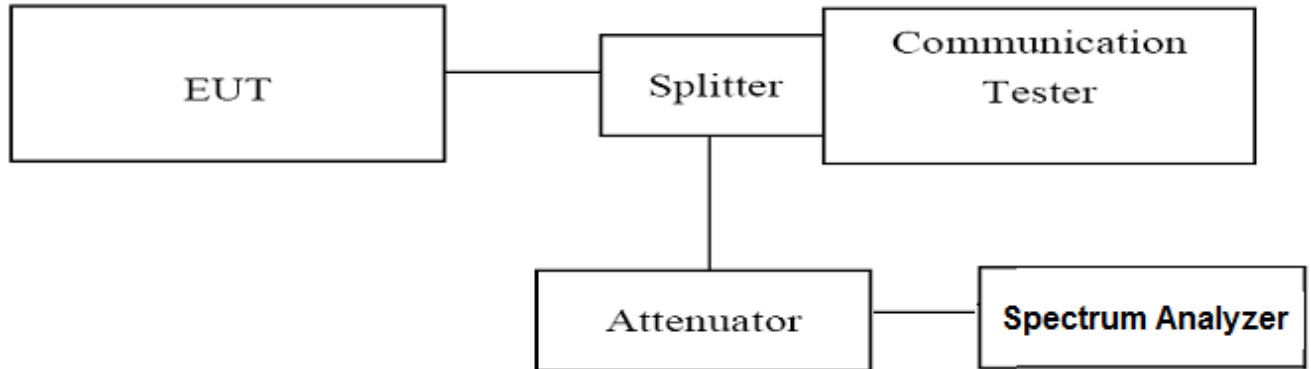

TEST PROCEDURE

1. The EUT was set up for the max output power with pseudo random data modulation;
2. The power was measured with Agilent Spectrum Analyzer N9030A;
3. Set RBW=5.1KHz,VBW=51KHz,Span=2MHz,SWT=300ms, Dector: RMS;
1. These measurements were done at 3 frequencies, 1850.20 MHz, 1880.00 MHz and 1909.80 MHz for PCS1900 band; 824.20 MHz, 836.60 MHz and 848.80 MHz for GSM850 band. (bottom, middle and top of operational frequency range).

TEST RESULTS

GSM/TM1/GSM850						
Channel Number	Frequency (MHz)	Measurement Results		Limit (dBm)	Refer to Plot	Verdict
		Frequency (MHz)	Values (dBm)			
128	824.20	823.986	-25.290	-13.00	Plot 4.4.1 A	PASS
251	848.80	849.022	-24.688	-13.00	Plot 4.4.1 B	PASS

GSM/TM3/ EGPRS850						
Channel Number	Frequency (MHz)	Measurement Results		Limit (dBm)	Refer to Plot	Verdict
		Frequency (MHz)	Values (dBm)			
128	824.20	823.978	-32.692	-13.00	Plot 4.4.2 A	PASS
251	848.80	849.008	-32.018	-13.00	Plot 4.4.2 B	PASS

GSM/TM1/GSM1900						
Channel Number	Frequency (MHz)	Measurement Results		Limit (dBm)	Refer to Plot	Verdict
		Frequency (MHz)	Values (dBm)			
512	1850.20	1849.998	-25.953	-13.00	Plot 4.4.3 A	PASS
810	1909.80	1910.016	-27.597	-13.00	Plot 4.4.3 B	PASS

GSM/TM3/ EGPRS1900						
Channel Number	Frequency (MHz)	Measurement Results		Limit (dBm)	Refer to Plot	Verdict
		Frequency (MHz)	Values (dBm)			
512	1850.20	1849.986	-34.026	-13.00	Plot 4.4.4 A	PASS
810	1909.80	1910.012	-35.715	-13.00	Plot 4.4.4 B	PASS

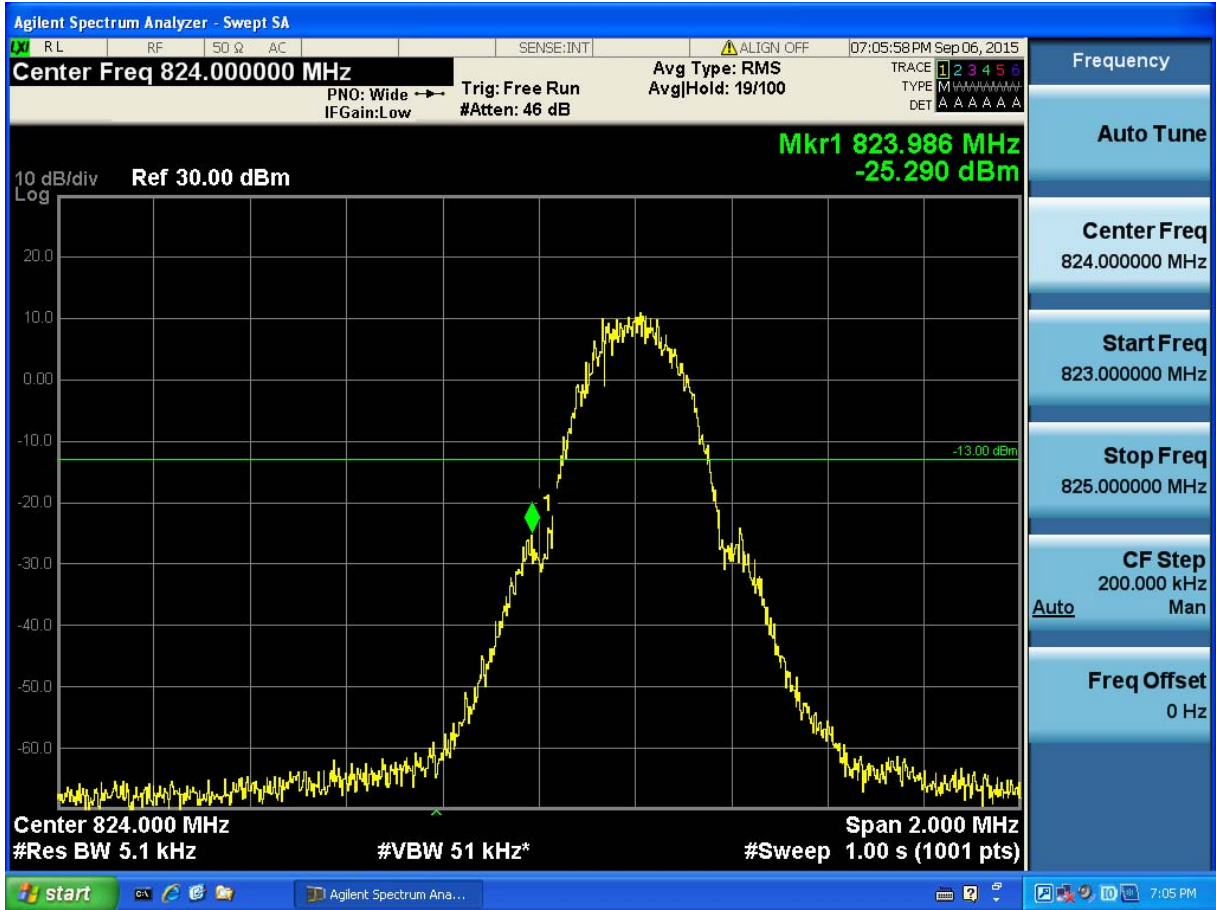

(Plot 4.4.1 A: Channel 128: 824.20MHz @ GSM850)

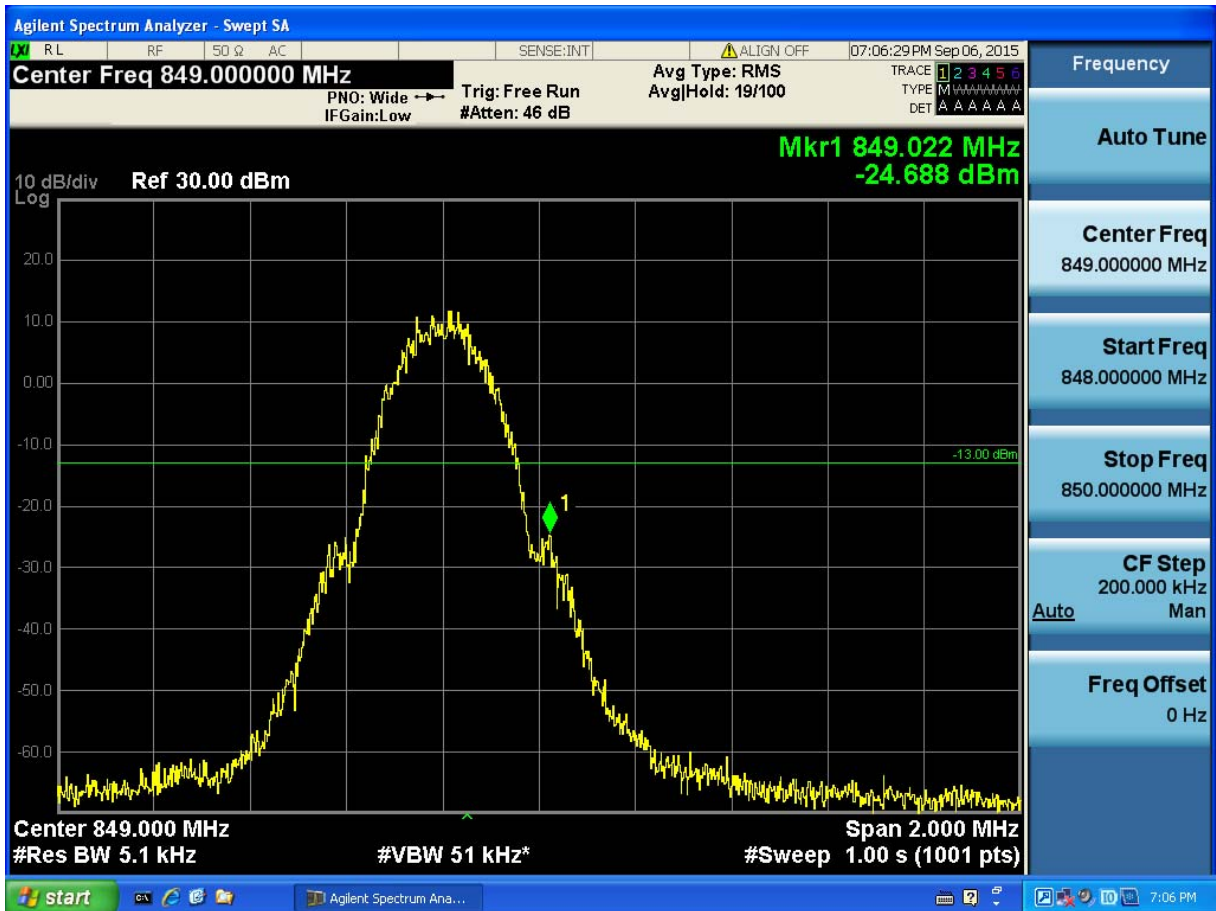

(Plot 4.4.1 B: Channel 251: 848.80MHz @ GSM850)

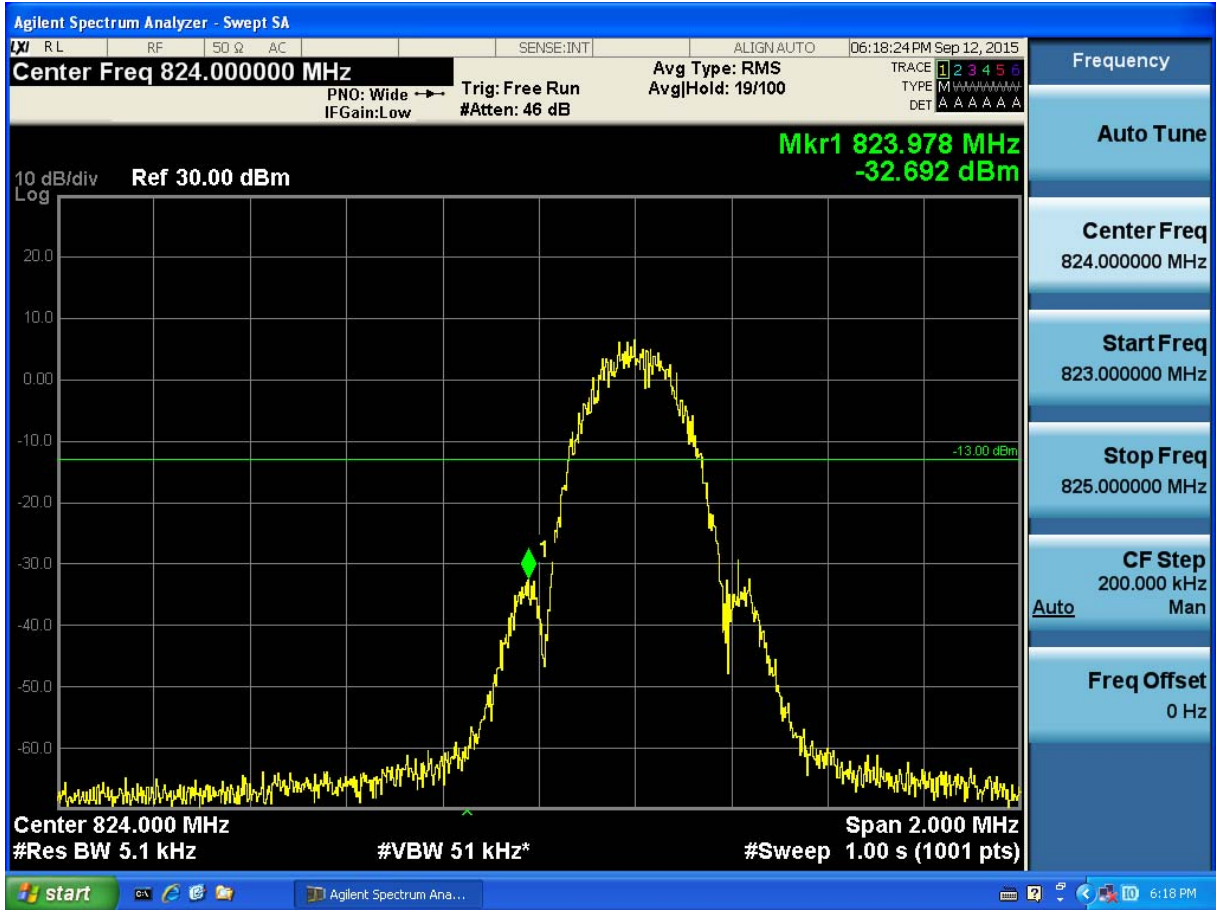

(Plot 4.4.2 A: Channel 128: 824.20MHz @ EGPRS850)

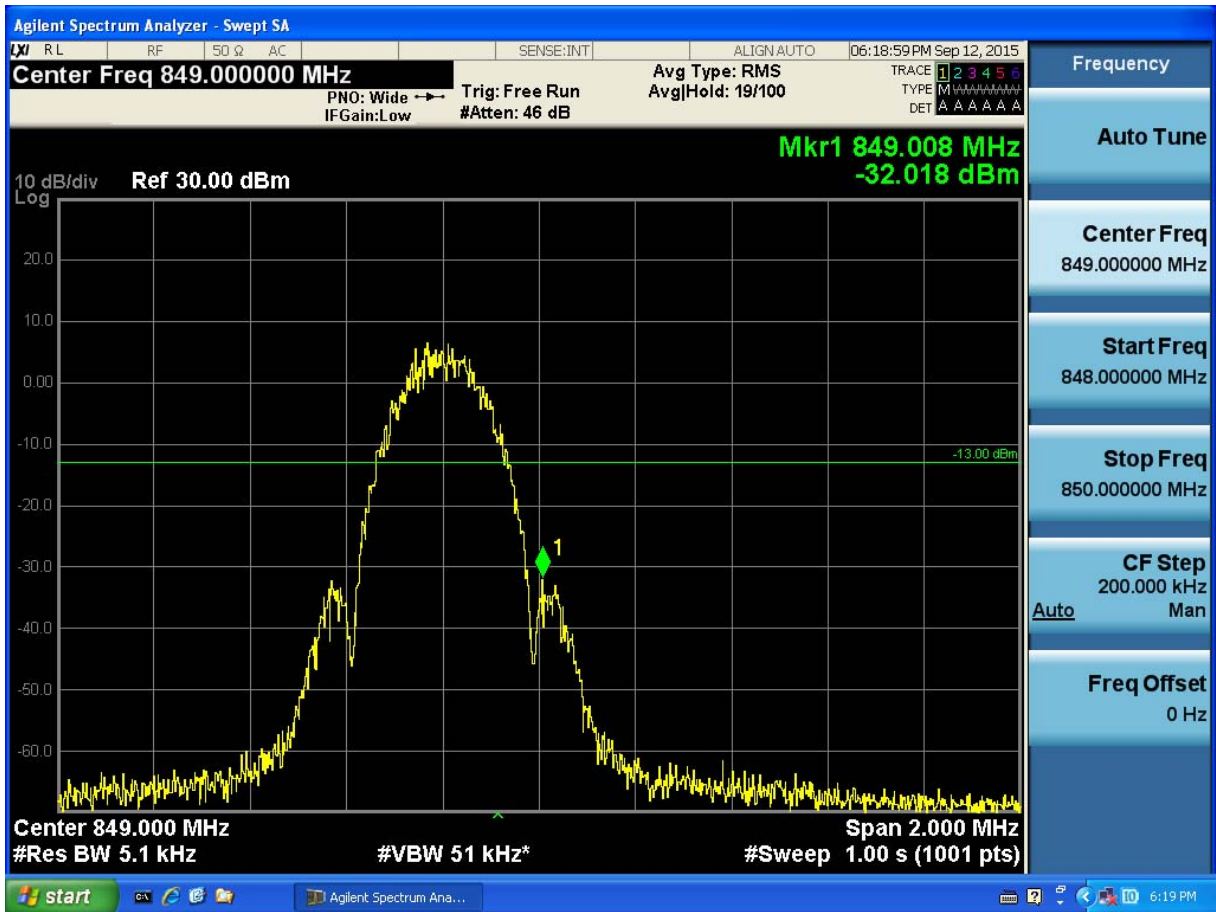

(Plot 4.4.2 B: Channel 251: 848.80MHz @ EGPRS850)

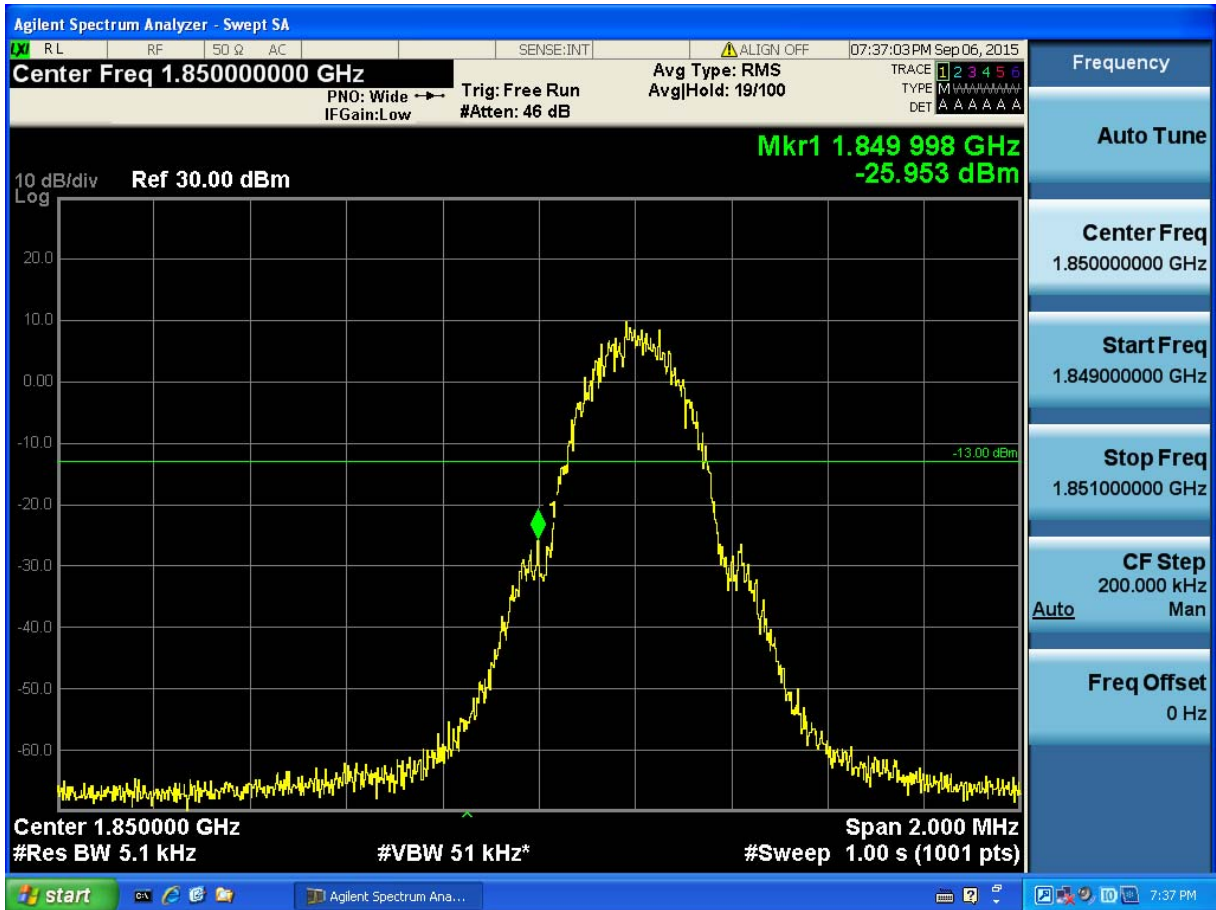

(Plot 4.4.3 A: Channel 512: 1850.20MHz @ PCS1900)

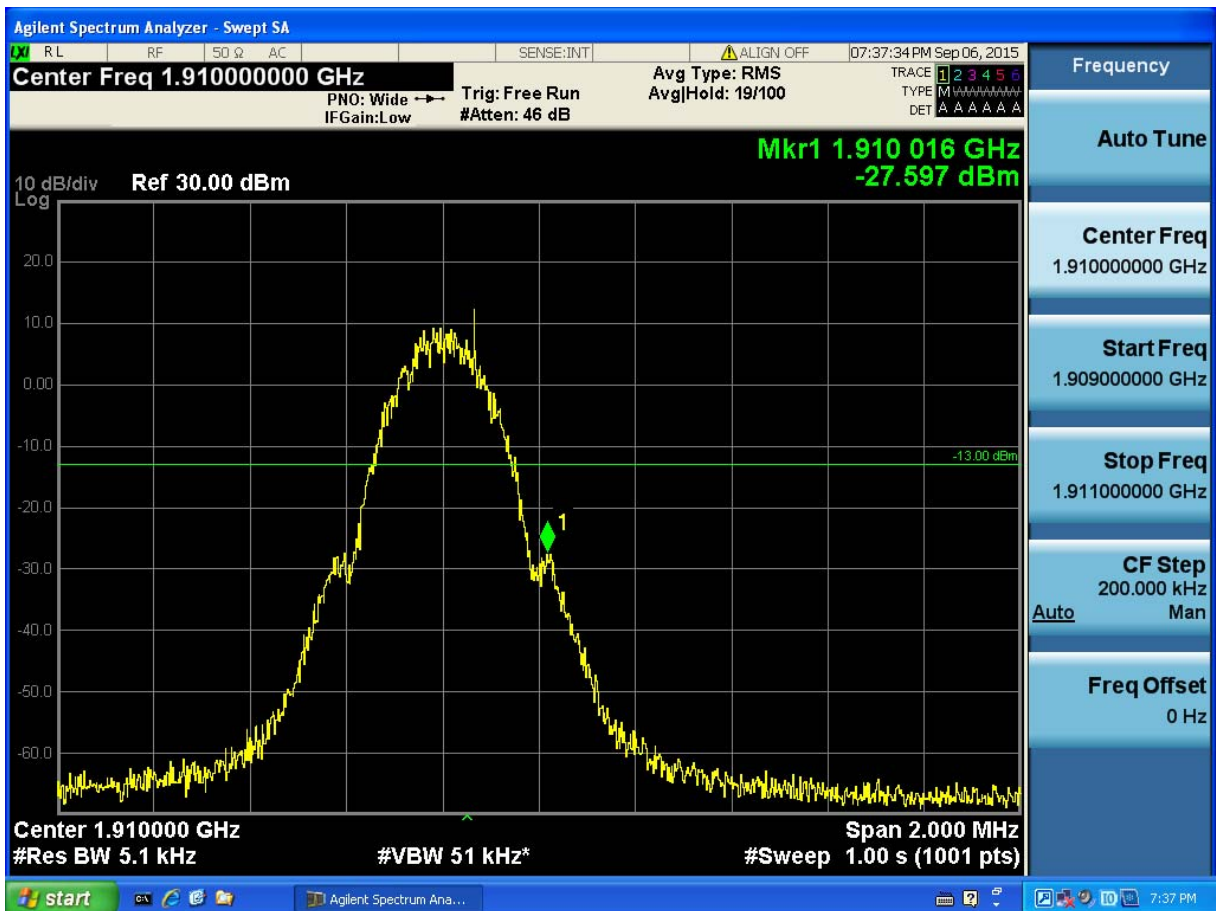

(Plot 4.4.3 B: Channel 810: 1909.80MHz @ PCS1900)

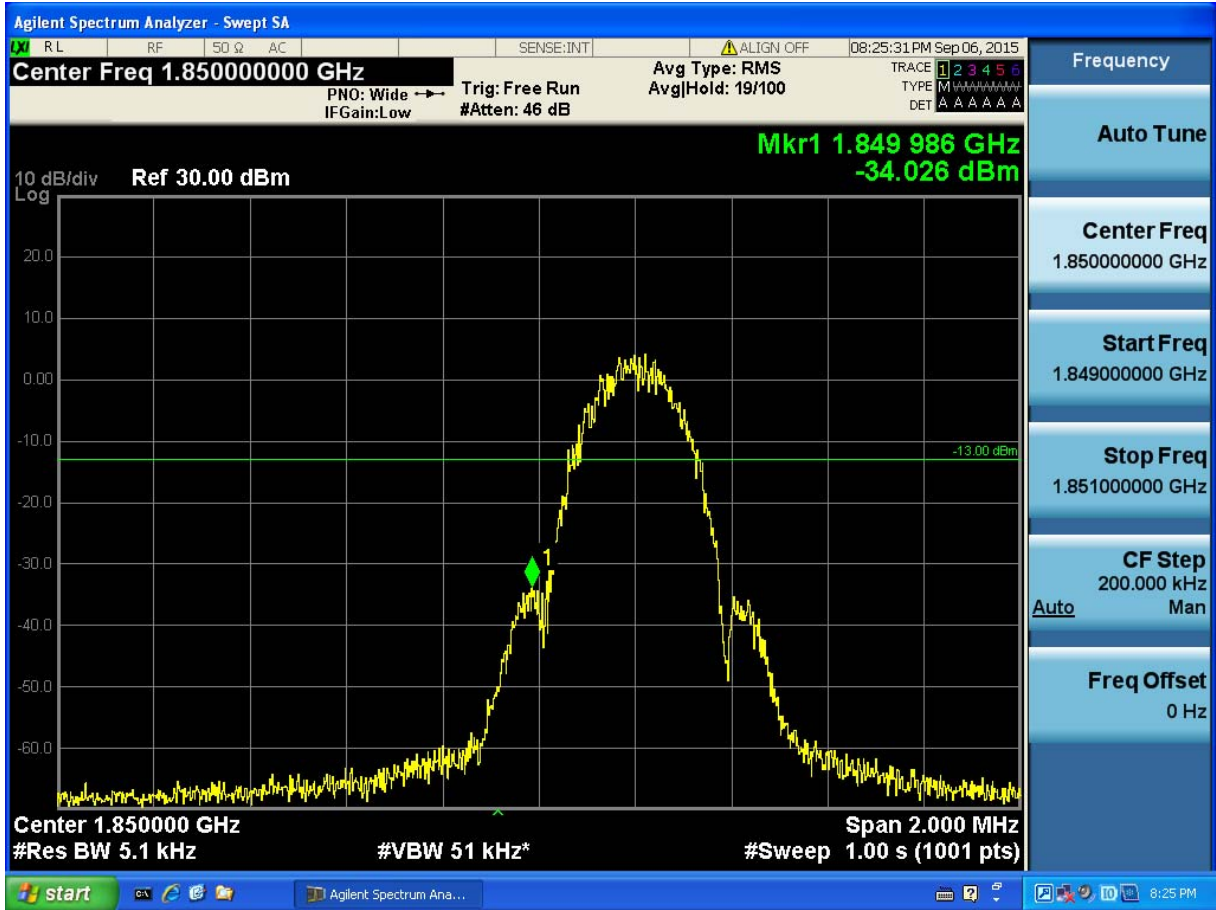

(Plot 4.4.4 A: Channel 512: 1850.20MHz @EGPRS1900)

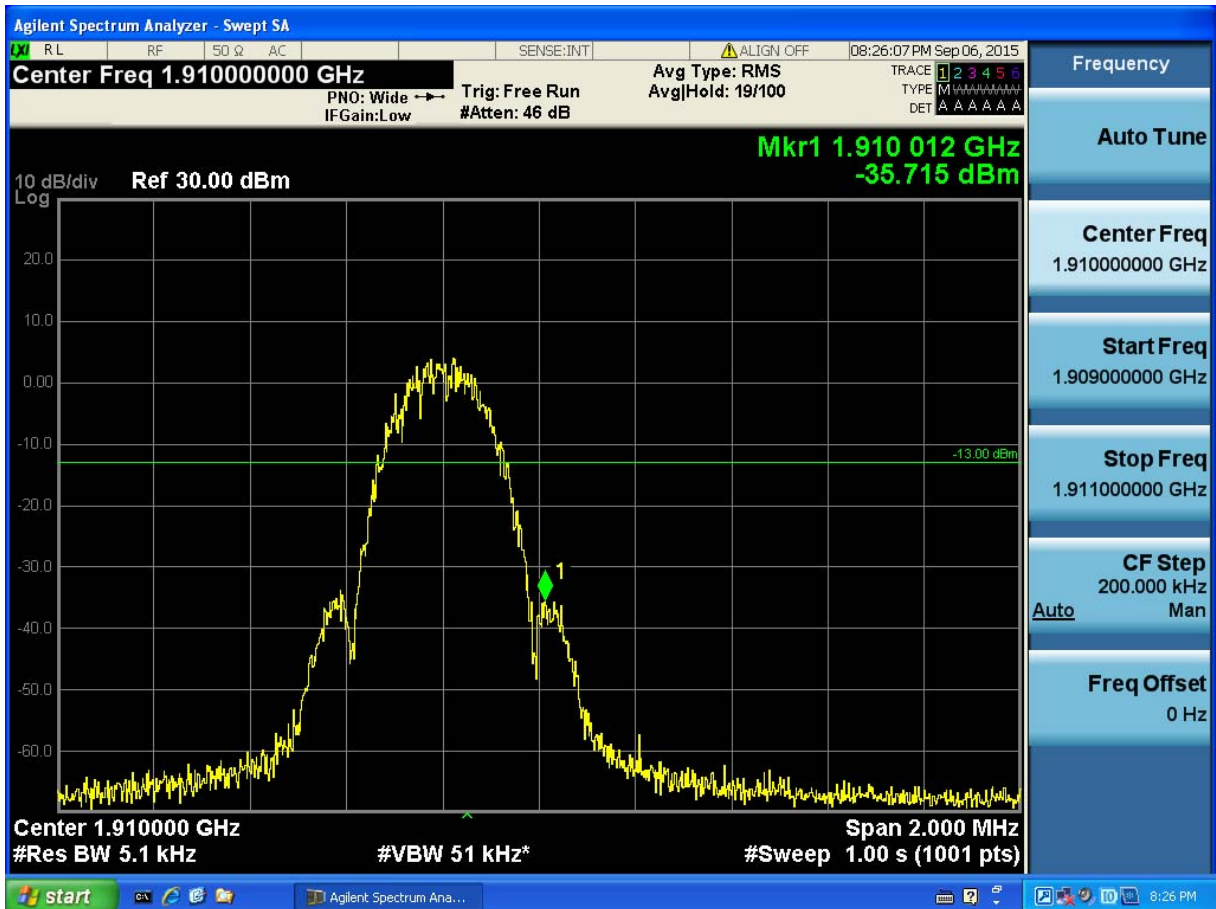

(Plot 4.4.4 B: Channel 810: 1909.80MHz @ EGPRS1900)

4.5 Spurious Emission on Antenna Port

TEST APPLICABLE

The following steps outline the procedure used to measure the conducted emissions from the EUT.

1. Determine frequency range for measurements: From CFR 2.1057 the spectrum should be investigated from the lowest radio frequency generated in the equipment up to at least the 10th harmonic of the carrier frequency. For the equipment of PCS1900 band, this equates to a frequency range of 9 KHz to 19.1 GHz, data taken from 9 KHz to 25 GHz. For GSM850, data taken from 9 KHz to 9 GHz.
2. The sweep time is set automatically by instrument itself. That should be the optimal sweep time for the span and the RBW. If the sweep time is too short, that is sweep is too fast, the sweep result is not accurate; if the sweep time is too long, that is sweep is too low, some frequency components may be lost. The instrument will give an optimal sweep time according the selected span and RBW.
3. The procedure to get the conducted spurious emission is as follows:
The trace mode is set to MaxHold to get the highest signal at each frequency;
Wait 25 seconds;
Get the result.
4. Determine EUT transmit frequencies: below outlines the band edge frequencies pertinent to conducted emissions testing.

TEST CONFIGURATION

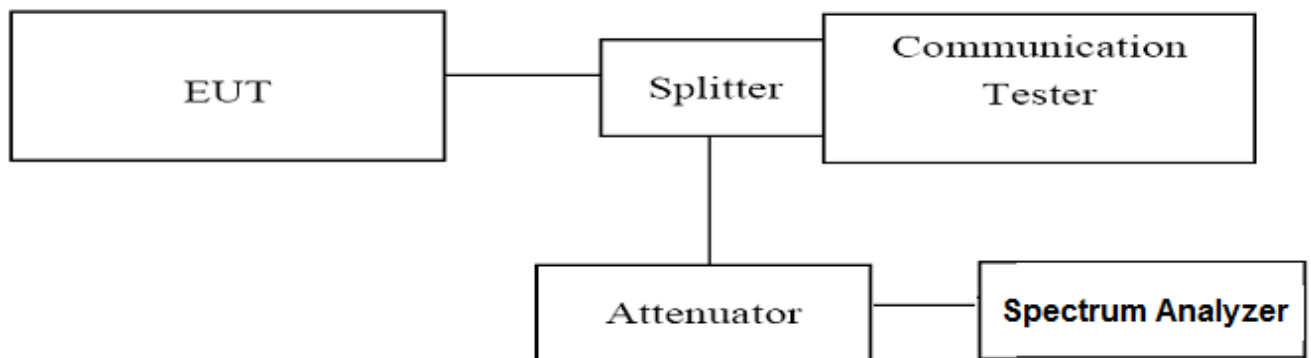

TEST PROCEDURE

1. The EUT was set up for the max output power with pseudo random data modulation;
2. The power was measured with Agilent Spectrum Analyzer N9030A (peak);
3. These measurements were done at 3 frequencies, 1850.20 MHz, 1880.00 MHz and 1909.80 MHz for PCS1900 band; 824.20 MHz, 836.60 MHz and 848.80 MHz for GSM850 band. (Low, middle and high of operational frequency range).

TEST LIMIT

Part 24.238 and Part 22.917 specify that the power of any emission outside of the authorized operating frequency ranges must be attenuated below the transmitting power (P) by a factor of at least $43 + 10 \log(P)$ dB.

The specification that emissions shall be attenuated below the transmitter power (P) by at least $43 + 10 \log(P)$ dB, translates in the relevant power range (1 to 0.001 W) to -13 dBm. At 1 W the specified minimum attenuation becomes 43 dB and relative to a 30 dBm (1 W) carrier becomes a limit of -13 dBm. At 0.001 W (0 dBm) the minimum attenuation is 13 dB, which again yields a limit of -13 dBm. In this way a translation of the specification from relative to absolute terms is carried out.

TEST RESULTS

4.5.1 For GSM/TM1/GSM850 Test Results

A. Test Verdict

Test Mode/ Channel	Frequency (MHz)	Frequency Range	Refer to Plot	Limit (dBm)	Verdict
GSM/TM1/GSM850 /128	824.20	9KHz-150KHz	Plot 4.5.1 A1	-13.00	PASS
		150KHz-30MHz	Plot 4.5.1 A2	-13.00	PASS
		30MHz-1GHz	Plot 4.5.1 A3	-13.00	PASS
		1GHz-9GHz	Plot 4.5.1 A4	-13.00	PASS
GSM/TM1/GSM850 /190	836.60	9KHz-150KHz	Plot 4.5.1 B1	-13.00	PASS
		150KHz-30MHz	Plot 4.5.1 B2	-13.00	PASS
		30MHz-1GHz	Plot 4.5.1 B3	-13.00	PASS
		1GHz-9GHz	Plot 4.5.1 B4	-13.00	PASS
GSM/TM1/GSM850 /251	848.80	9KHz-150KHz	Plot 4.5.1 C1	-13.00	PASS
		150KHz-30MHz	Plot 4.5.1 C2	-13.00	PASS
		30MHz-1GHz	Plot 4.5.1 C3	-13.00	PASS
		1GHz-9GHz	Plot 4.5.1 C4	-13.00	PASS

Note:

1. In general, the worse case attenuation requirement shown above was applied.
2. "----" means that the emission level is too low to be measured or at least 20 dB down than the limit.

B. Test Plots

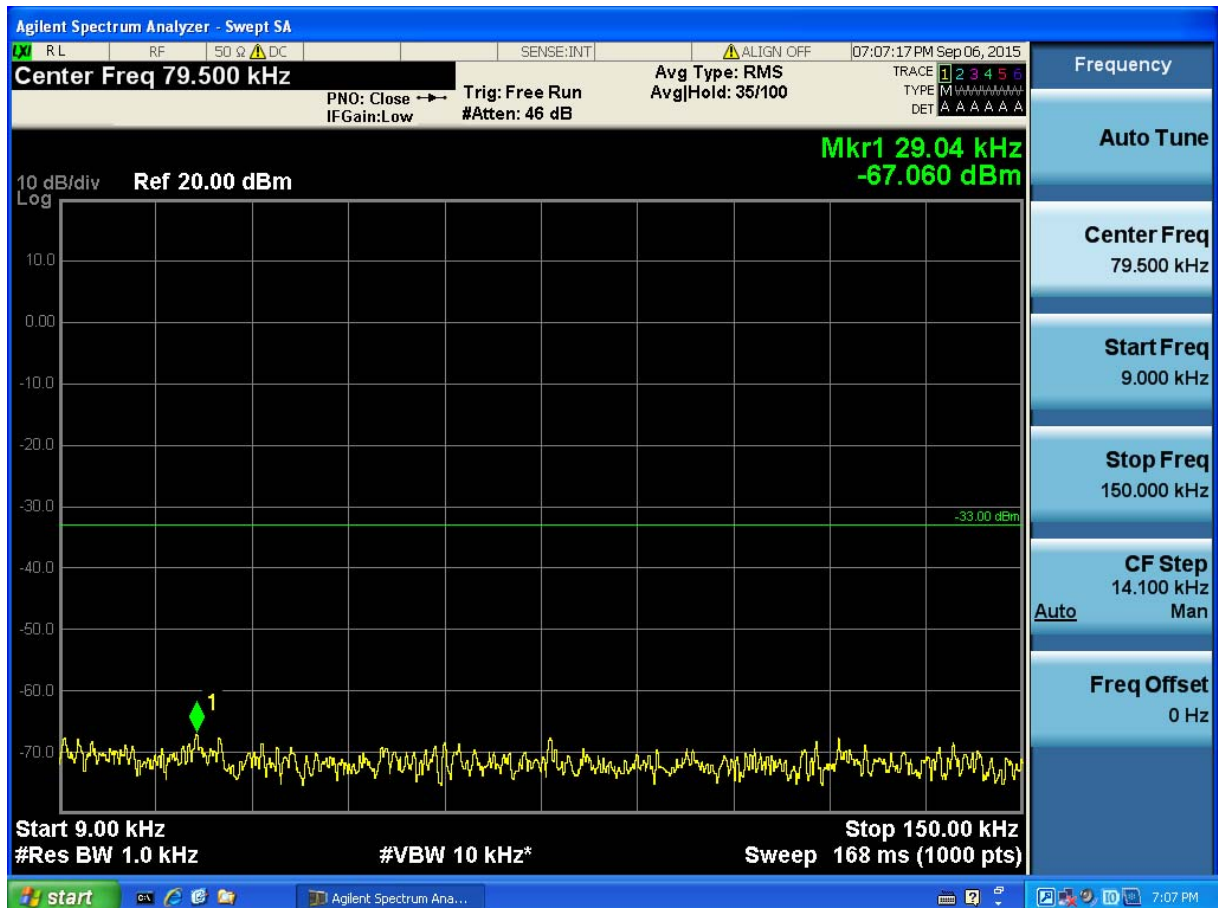

(Plot 4.5.1 A1: Channel 128: 824.20MHz @ Traffic @ GSM850)



(Plot 4.5.1 A2: Channel 128: 824.20MHz @ Traffic @ GSM850)

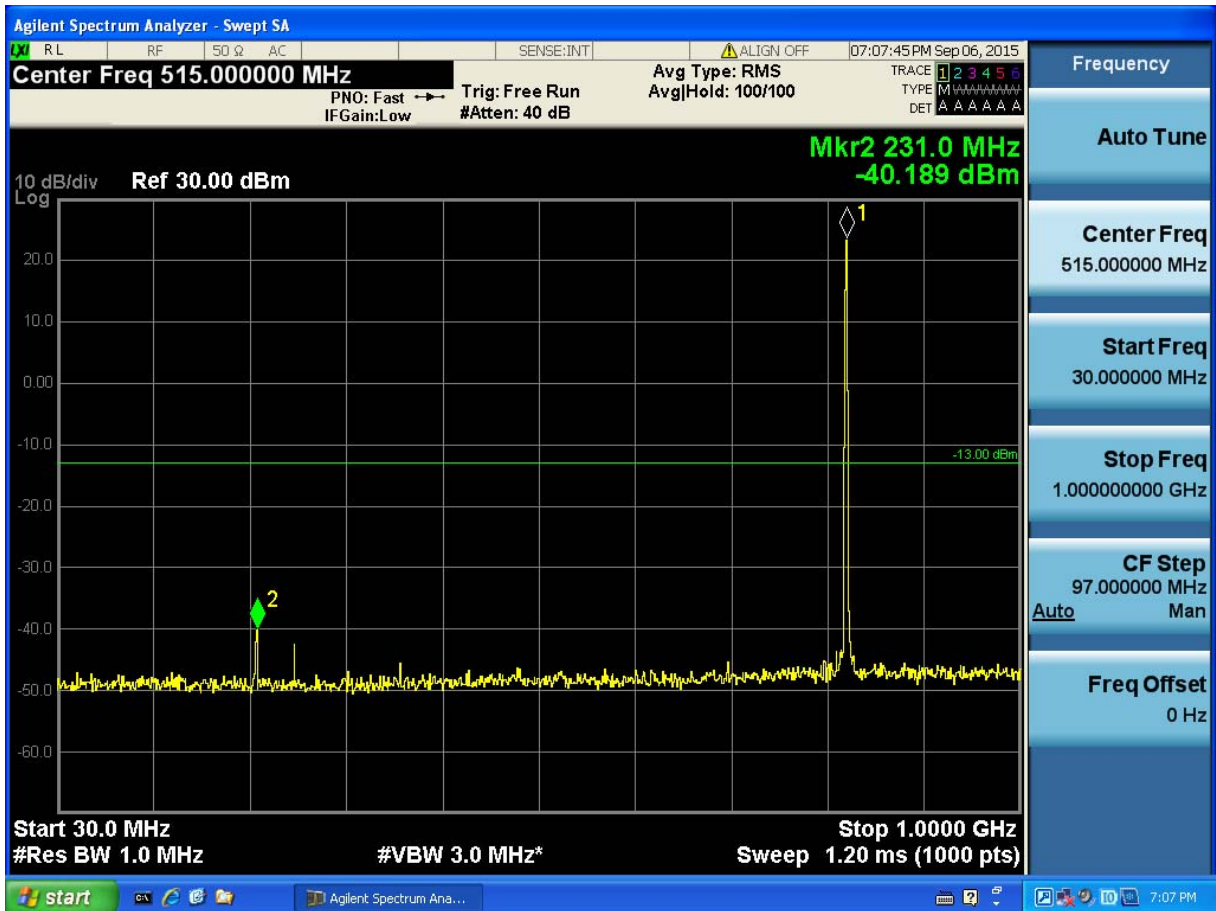

(Plot 4.5.1 A3: Channel 128: 824.20MHz @ Traffic @ GSM850)

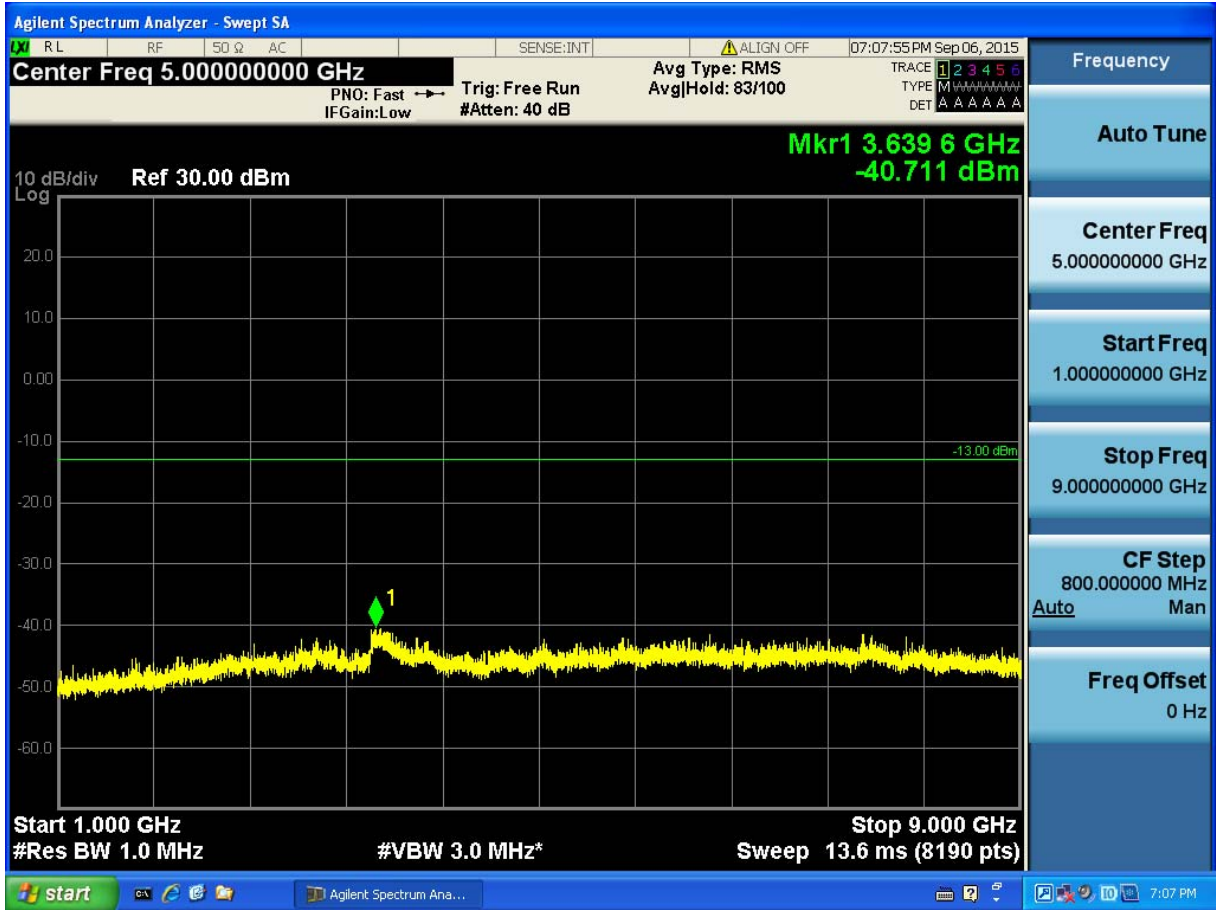

(Plot 4.5.1 A4: Channel 128: 824.20MHz @ Traffic @ GSM850)

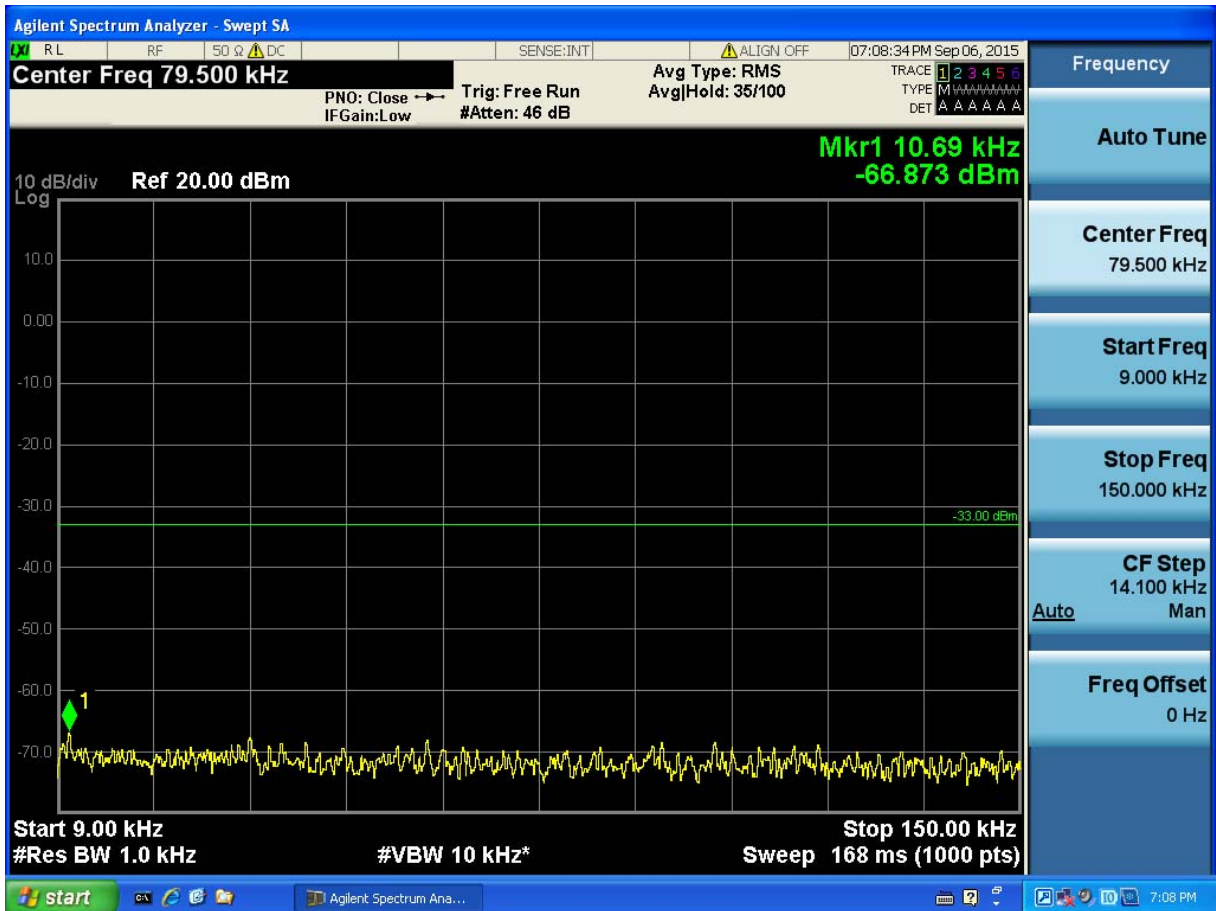

(Plot 4.5.1 B1: Channel 190: 836.60MHz @ Traffic @ GSM850)



(Plot 4.5.1 B2: Channel 190: 836.60MHz @ Traffic @ GSM850)

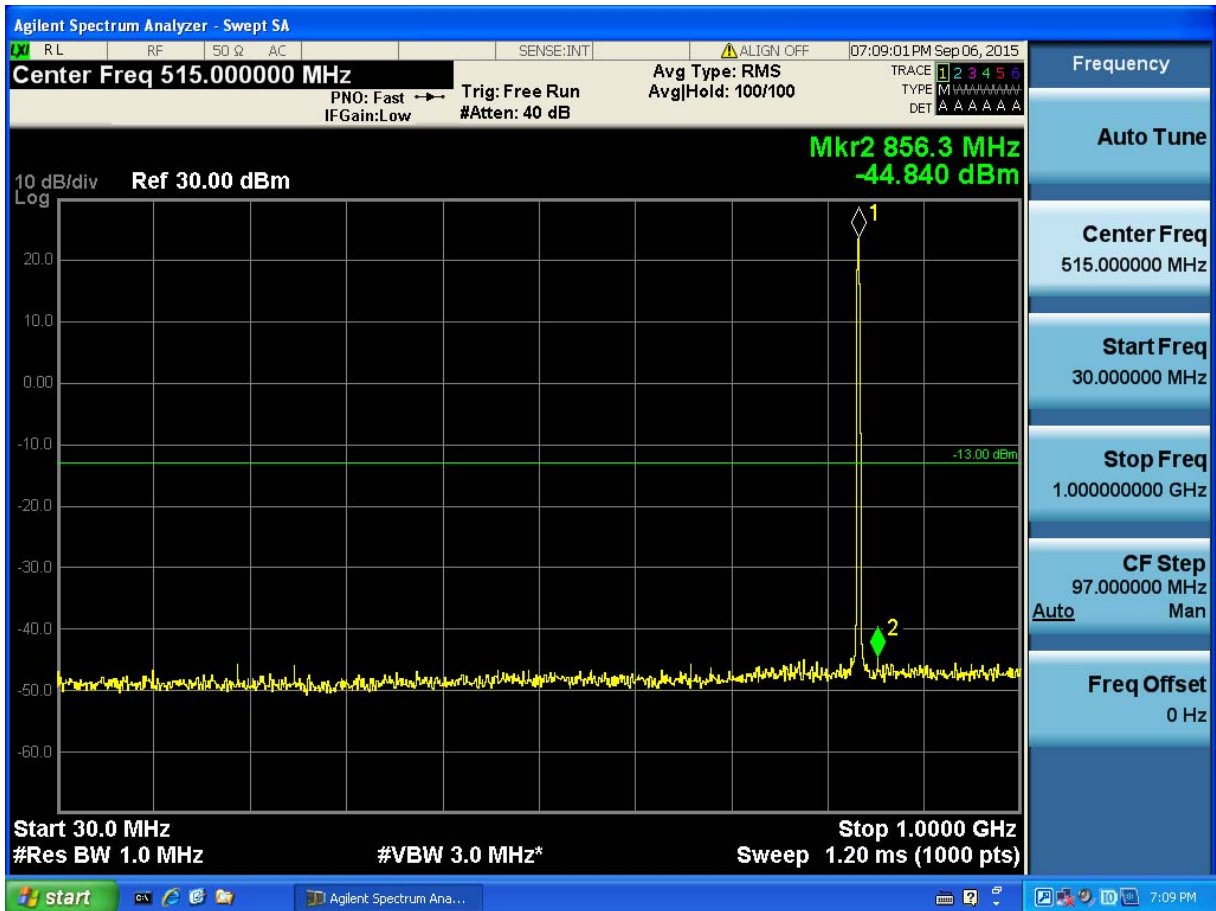

(Plot 4.5.1 B3: Channel 190: 836.60MHz @ Traffic @ GSM850)

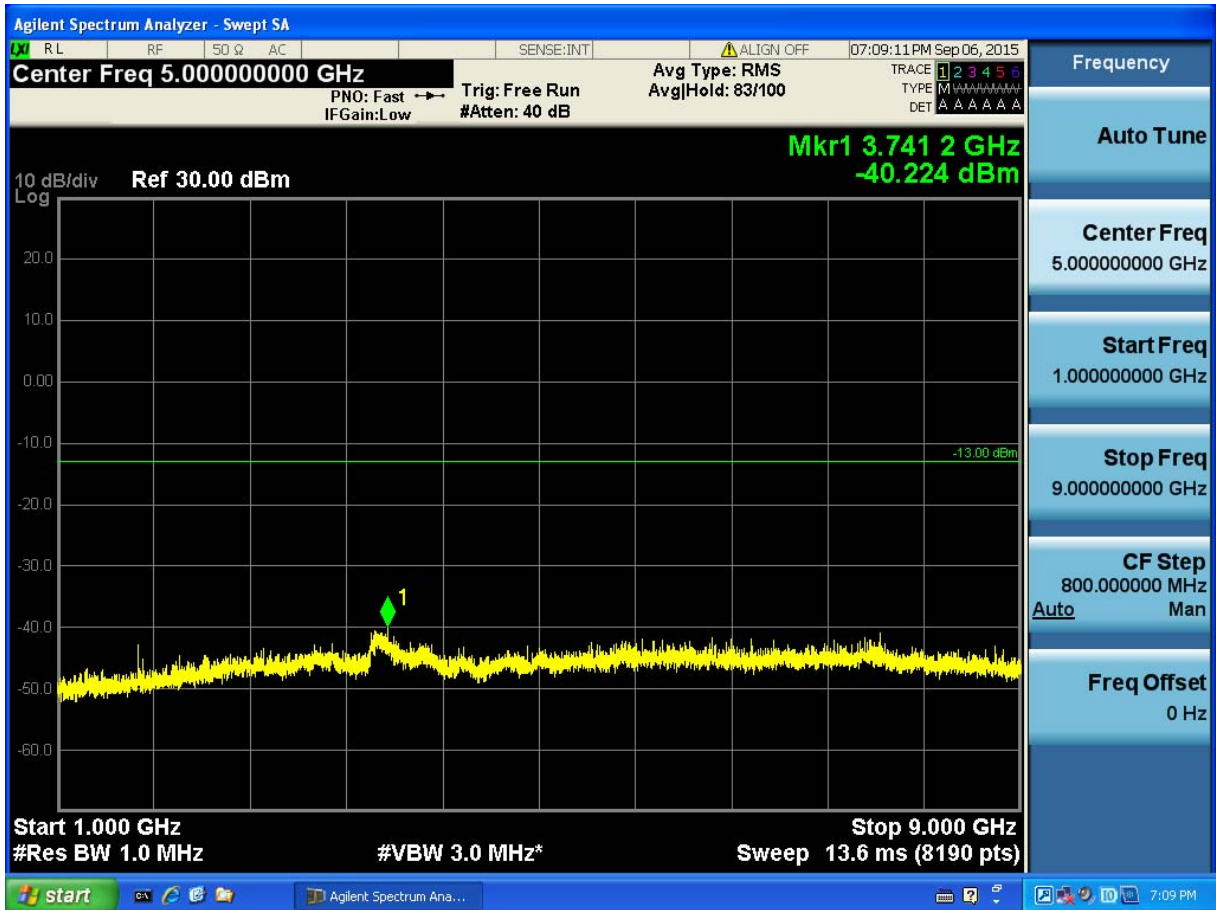

(Plot 4.5.1 B4: Channel 190: 836.60MHz @ Traffic @ GSM850)

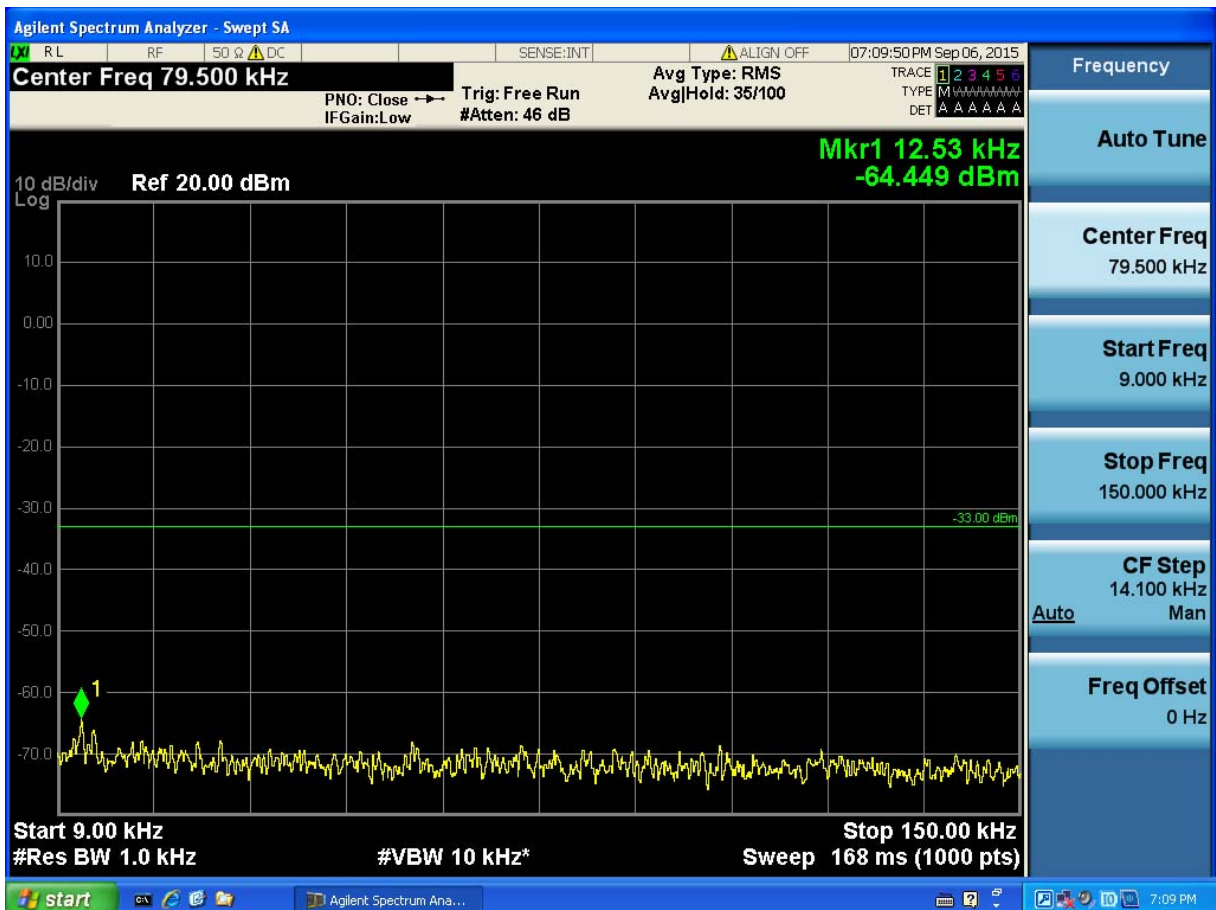

(Plot 4.5.1 C1: Channel 251: 848.80MHz @ Traffic @ GSM850)



(Plot 4.5.1 C2: Channel 251: 848.80MHz @ Traffic @ GSM850)

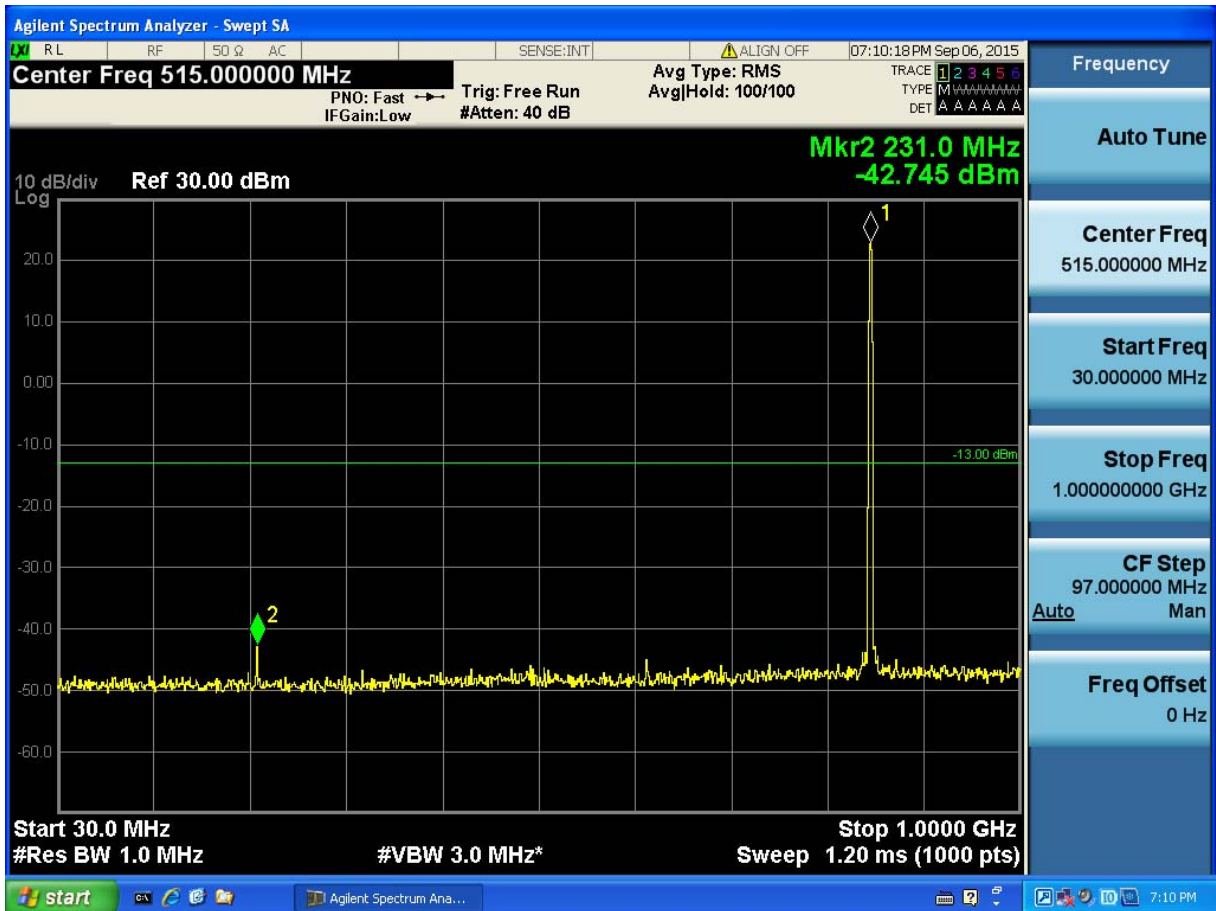

(Plot 4.5.1 C3: Channel 251: 848.80MHz @ Traffic @ GSM850)



(Plot 4.5.1 C4: Channel 251: 848.80MHz @ Traffic @ GSM850)

4.5.2 For GSM/TM1/GSM 1900 Test Results

A. Test Verdict

Test Mode/ Channel	Frequency (MHz)	Frequency Range	Refer to Plot	Limit (dBm)	Verdict
GSM/TM1/GSM1900 /512	1850.20	9KHz-150KHz	Plot 4.5.2 A1	-13.00	PASS
		150KHz-30MHz	Plot 4.5.2 A2	-13.00	PASS
		30MHz-1GHz	Plot 4.5.2 A3	-13.00	PASS
		1GHz-7GHz	Plot 4.5.2 A4	-13.00	PASS
		7 GHz-13.5 GHz	Plot 4.5.2 A5	-13.00	PASS
		13.5 GHz -20GHz	Plot 4.5.2 A6	-13.00	PASS
GSM/TM1/GSM1900 /661	1880.00	9KHz-150KHz	Plot 4.5.2 A1	-13.00	PASS
		150KHz-30MHz	Plot 4.5.2 A2	-13.00	PASS
		30MHz-1GHz	Plot 4.5.2 A3	-13.00	PASS
		1GHz-7GHz	Plot 4.5.2 A4	-13.00	PASS
		7 GHz-13.5 GHz	Plot 4.5.2 A5	-13.00	PASS
		13.5 GHz -20GHz	Plot 4.5.2 A6	-13.00	PASS
GSM/TM1/GSM1900 /810	1909.80	9KHz-150KHz	Plot 4.5.2 A1	-13.00	PASS
		150KHz-30MHz	Plot 4.5.2 A2	-13.00	PASS
		30MHz-1GHz	Plot 4.5.2 A3	-13.00	PASS
		1GHz-7GHz	Plot 4.5.2 A4	-13.00	PASS
		7 GHz-13.5 GHz	Plot 4.5.2 A5	-13.00	PASS
		13.5 GHz -20GHz	Plot 4.5.2 A6	-13.00	PASS

Note:

1. In general, the worse case attenuation requirement shown above was applied.
2. "----" means that the emission level is too low to be measured or at least 20 dB down than the limit.

B. Test Plots

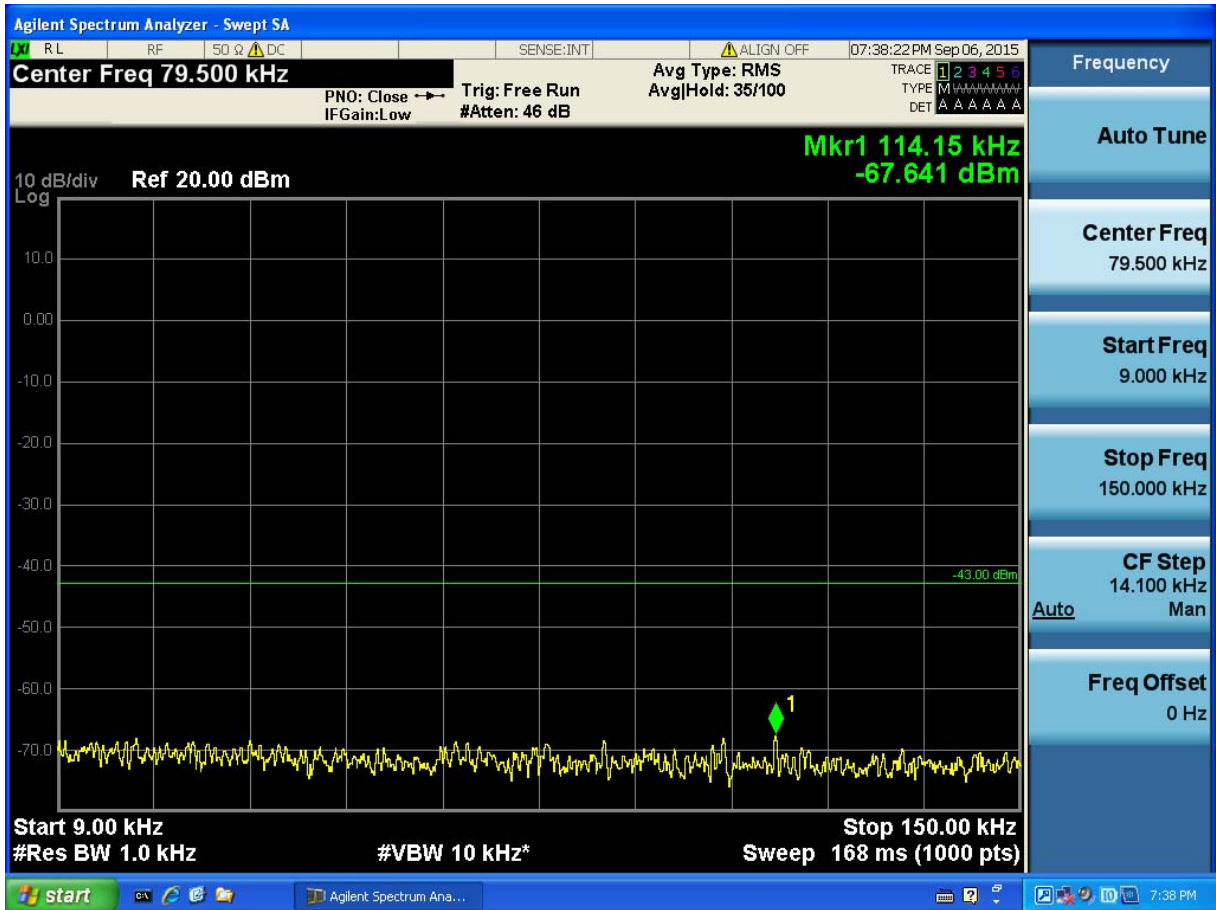

(Plot 4.5.2 A1: Channel 512: 1850.20MHz @ Traffic @ PCS1900)



(Plot 4.5.2 A2: Channel 512: 1850.20MHz @ Traffic @ PCS1900)

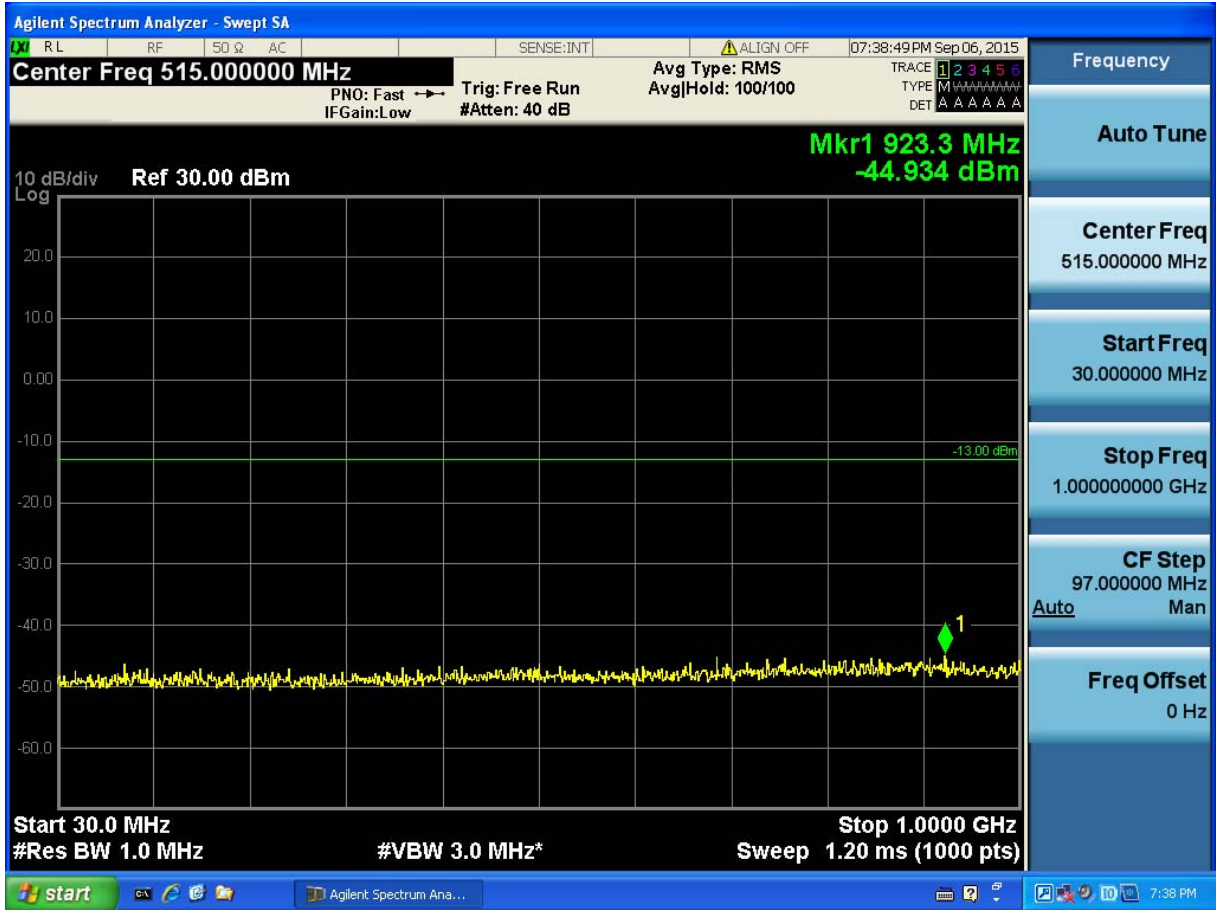

(Plot 4.5.2 A3: Channel 512: 1850.20MHz @ Traffic @ PCS1900)

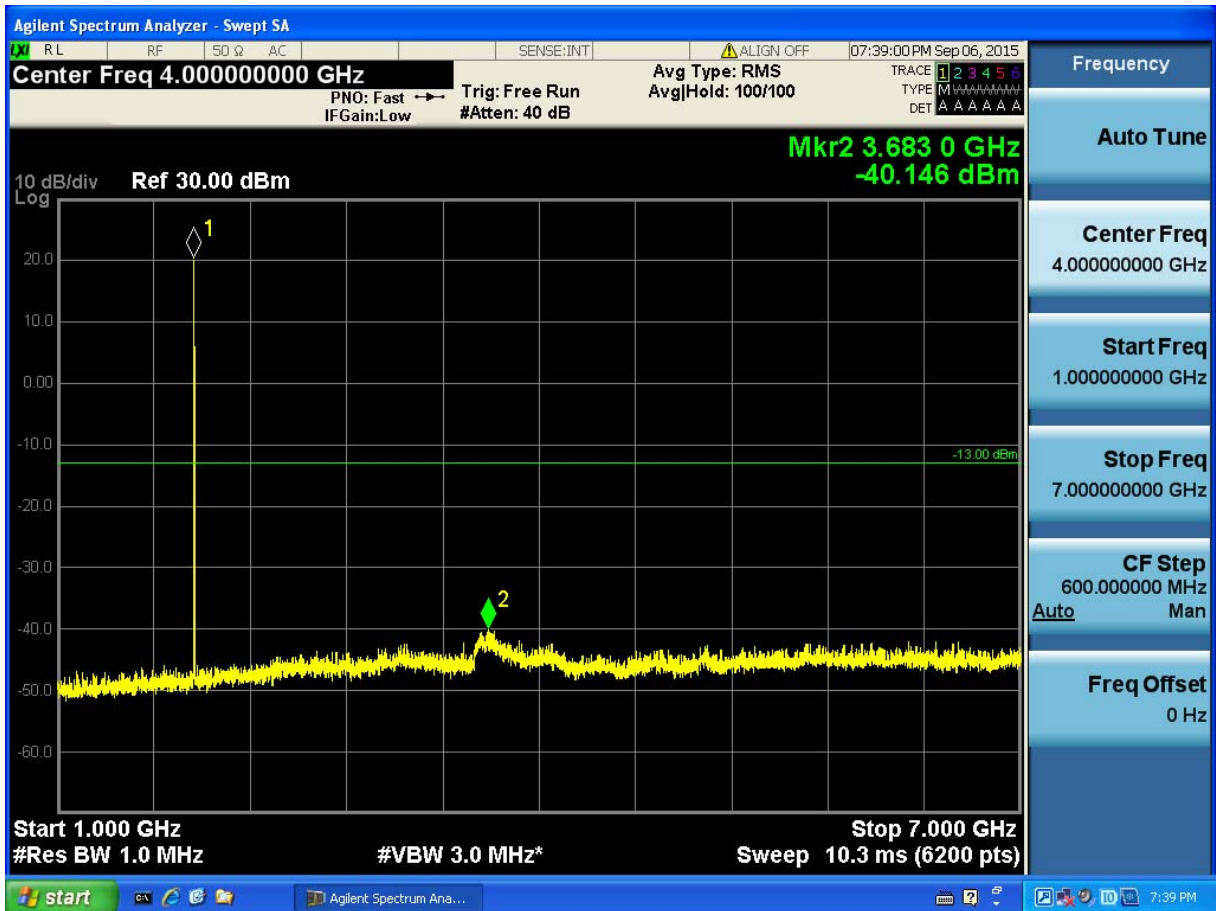

(Plot 4.5.2 A4: Channel 512: 1850.20MHz @ Traffic @ PCS1900)

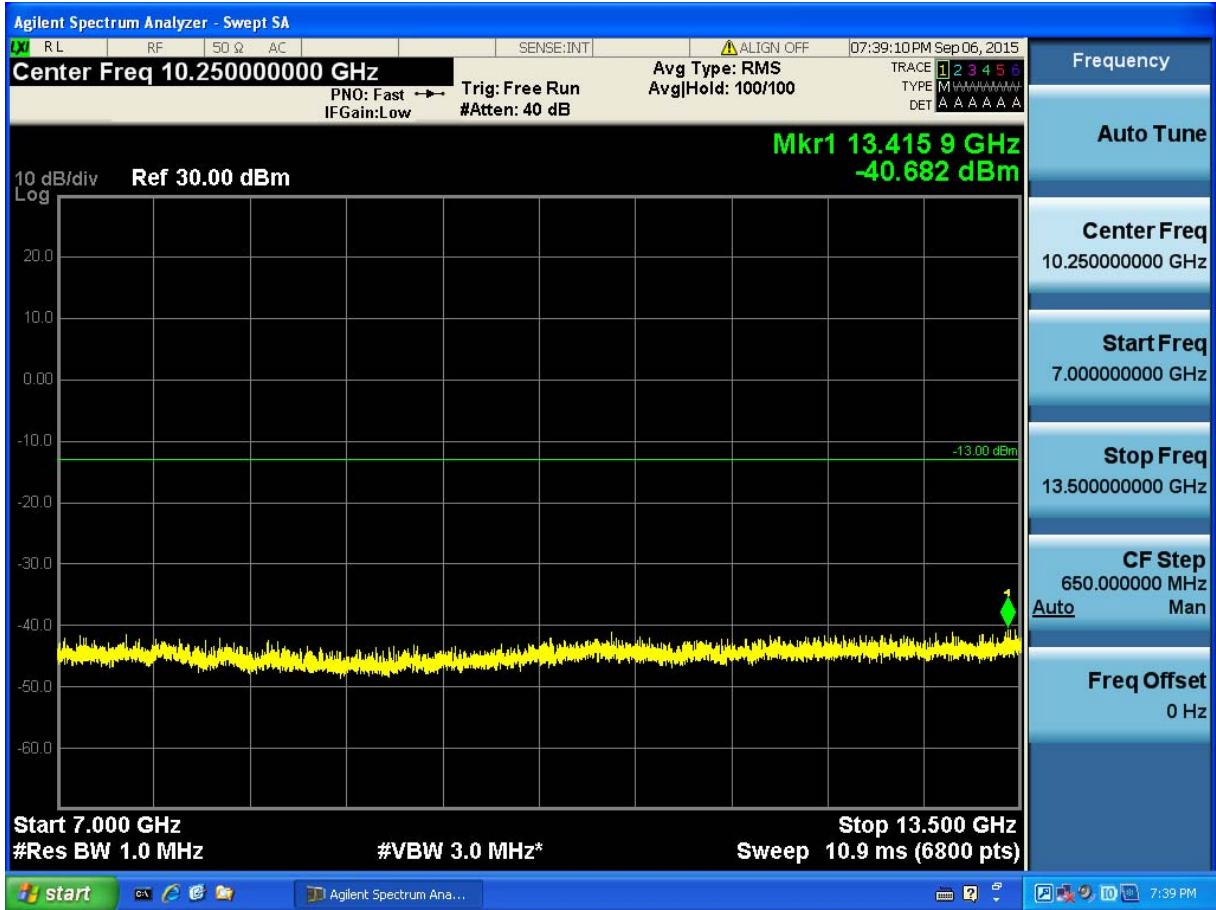

(Plot 4.5.2 A5: Channel 512: 1850.20MHz @ Traffic @ PCS1900)



(Plot 4.56.2 A6: Channel 512: 1850.20MHz @ Traffic @ PCS1900)

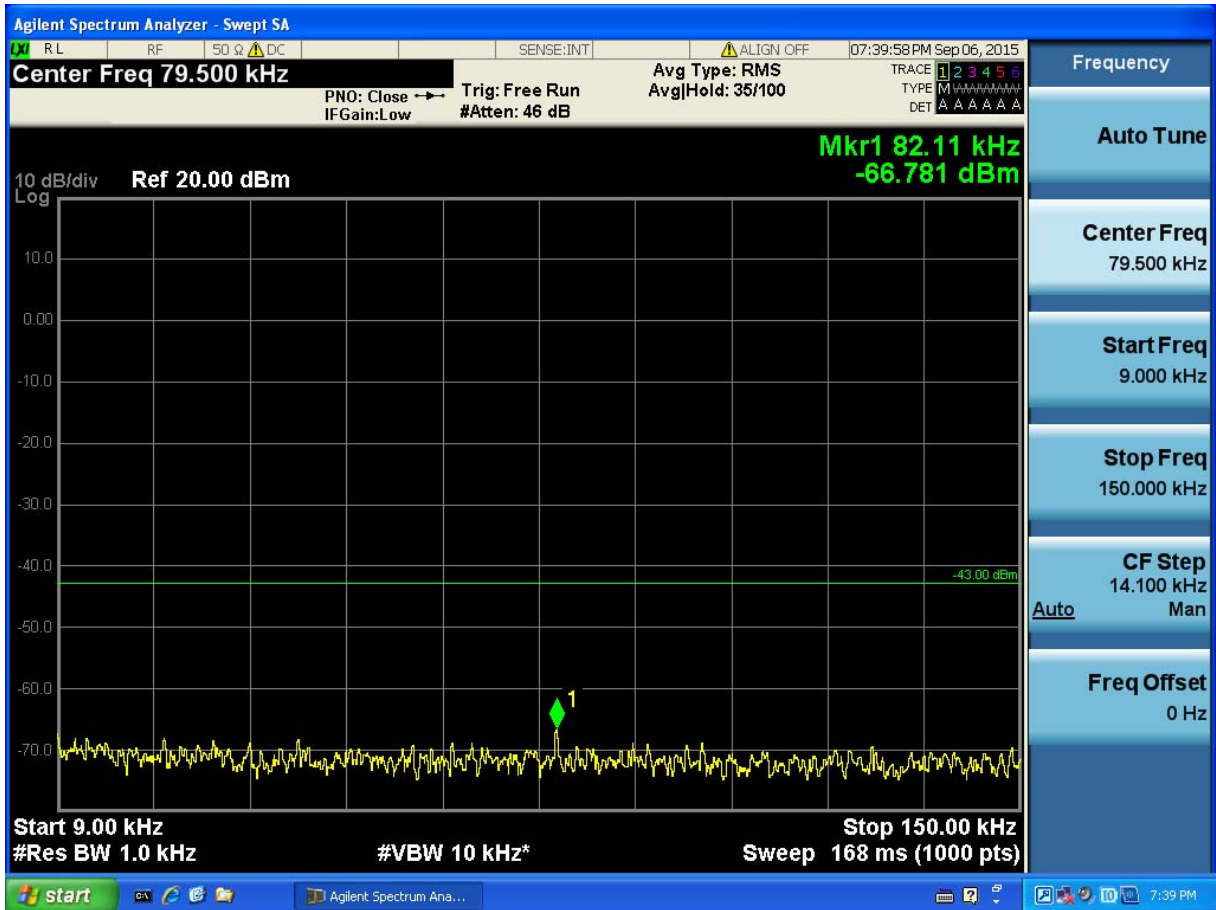

(Plot 4.5.2 B1: Channel 661: 1880.00MHz @ Traffic @ PCS1900)



(Plot 4.5.2 B2: Channel 661: 1880.00MHz @ Traffic @ PCS1900)

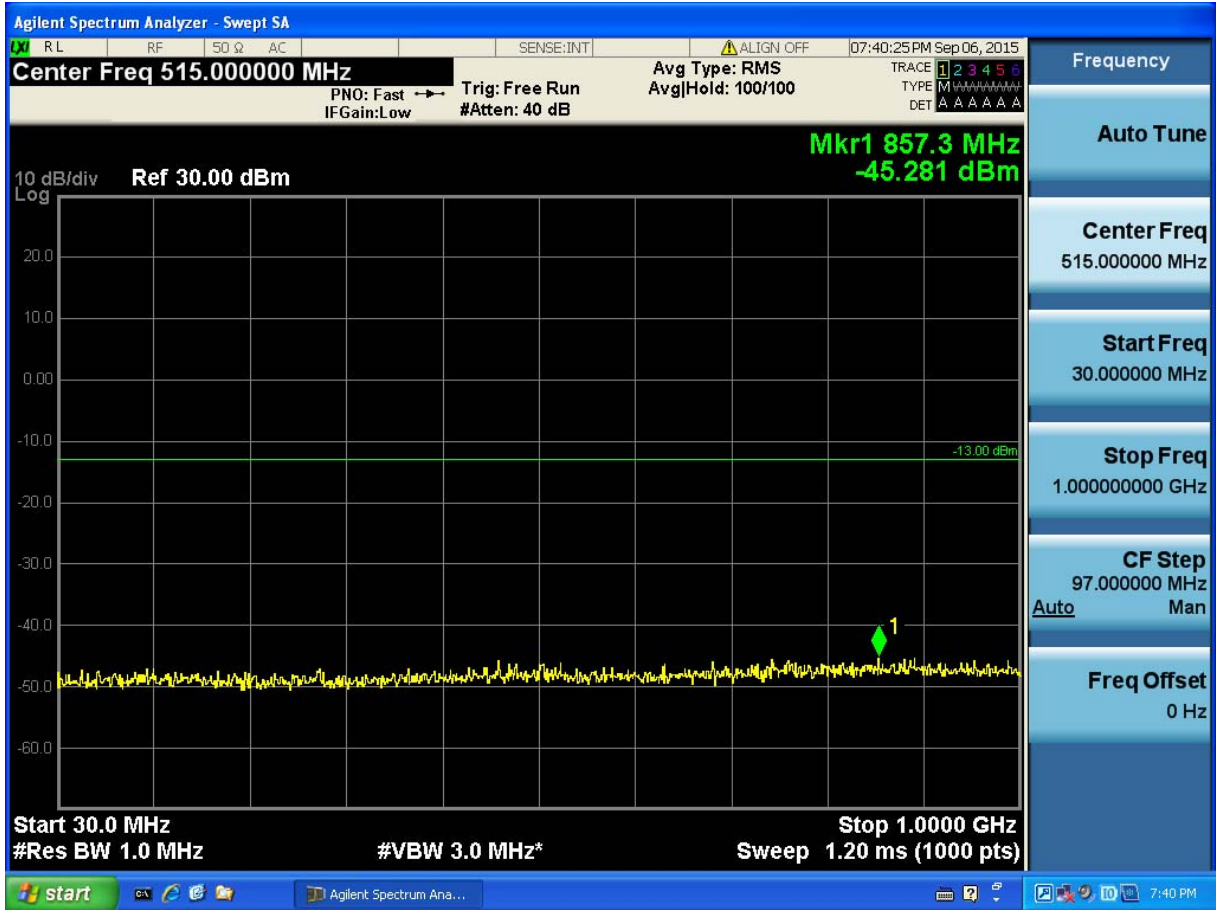

(Plot 4.5.2 B3: Channel 661: 1880.00MHz @ Traffic @ PCS1900)

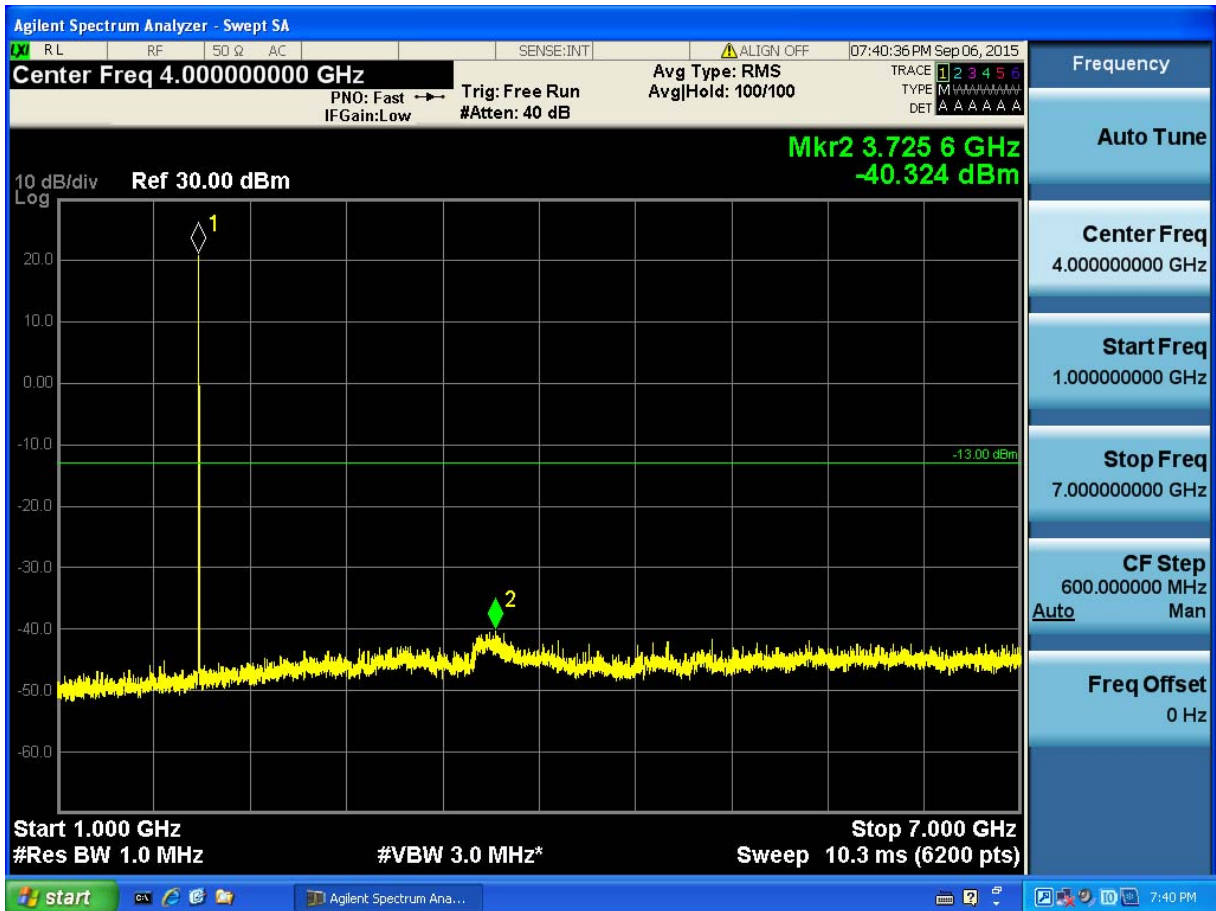

(Plot 4.5.2 B4: Channel 661: 1880.00MHz @ Traffic @ PCS1900)



(Plot 4.5.2 B5: Channel 661: 1880.00MHz @ Traffic @ PCS1900)



(Plot 4.5.2 B6: Channel 661: 1880.00MHz @ Traffic @ PCS1900)

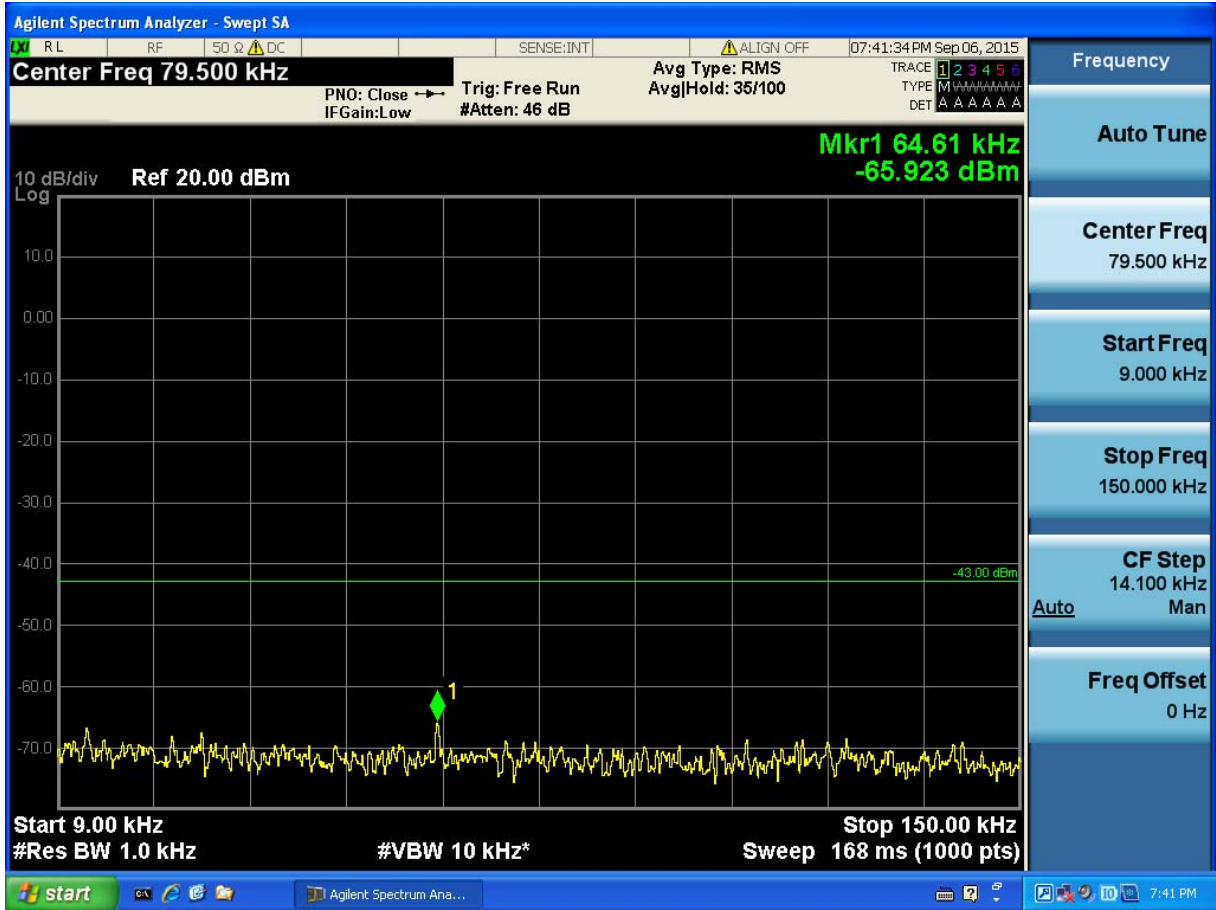

(Plot 4.5.2 C1: Channel 810: 1909.80MHz @ Traffic @ PCS1900)

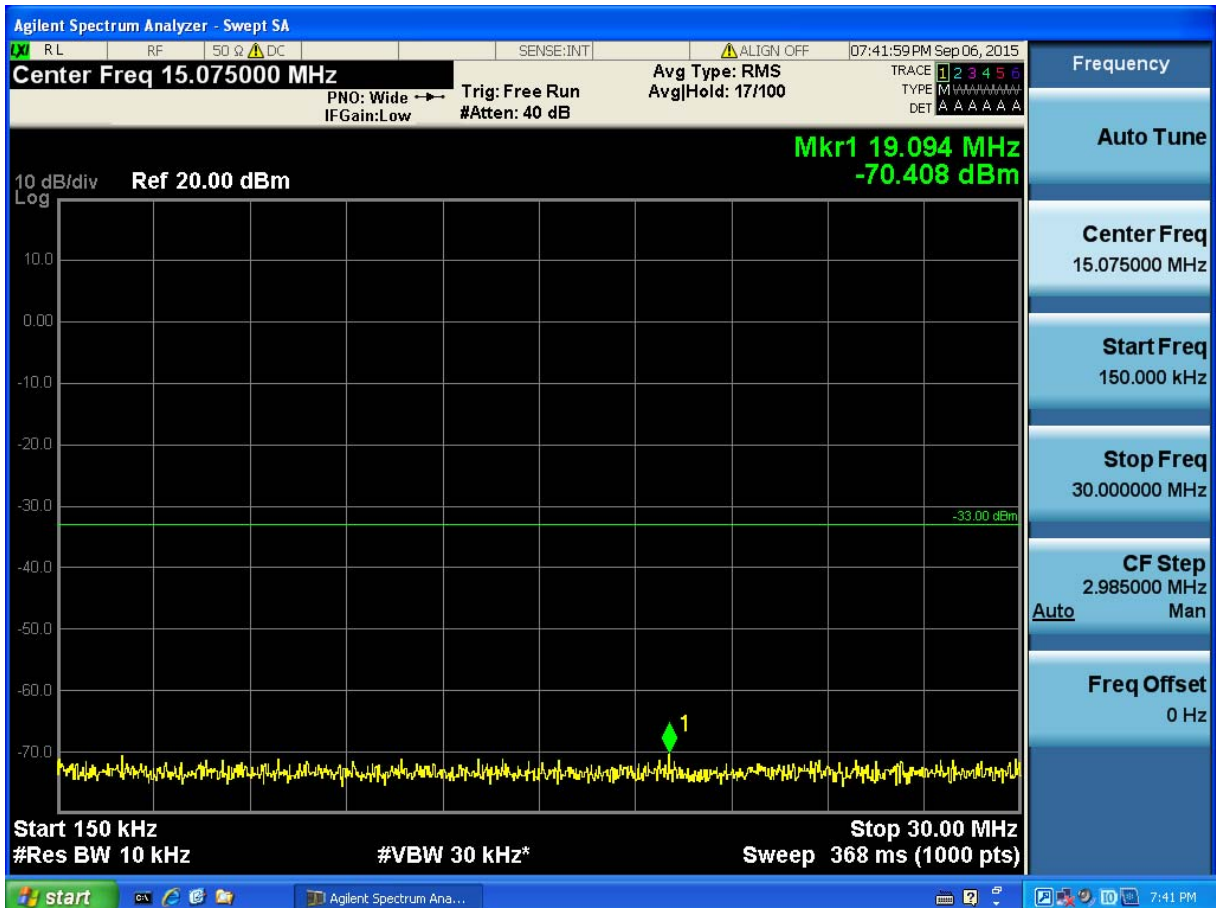

(Plot 4.5.2 C2: Channel 810: 1909.80MHz @ Traffic @ PCS1900)

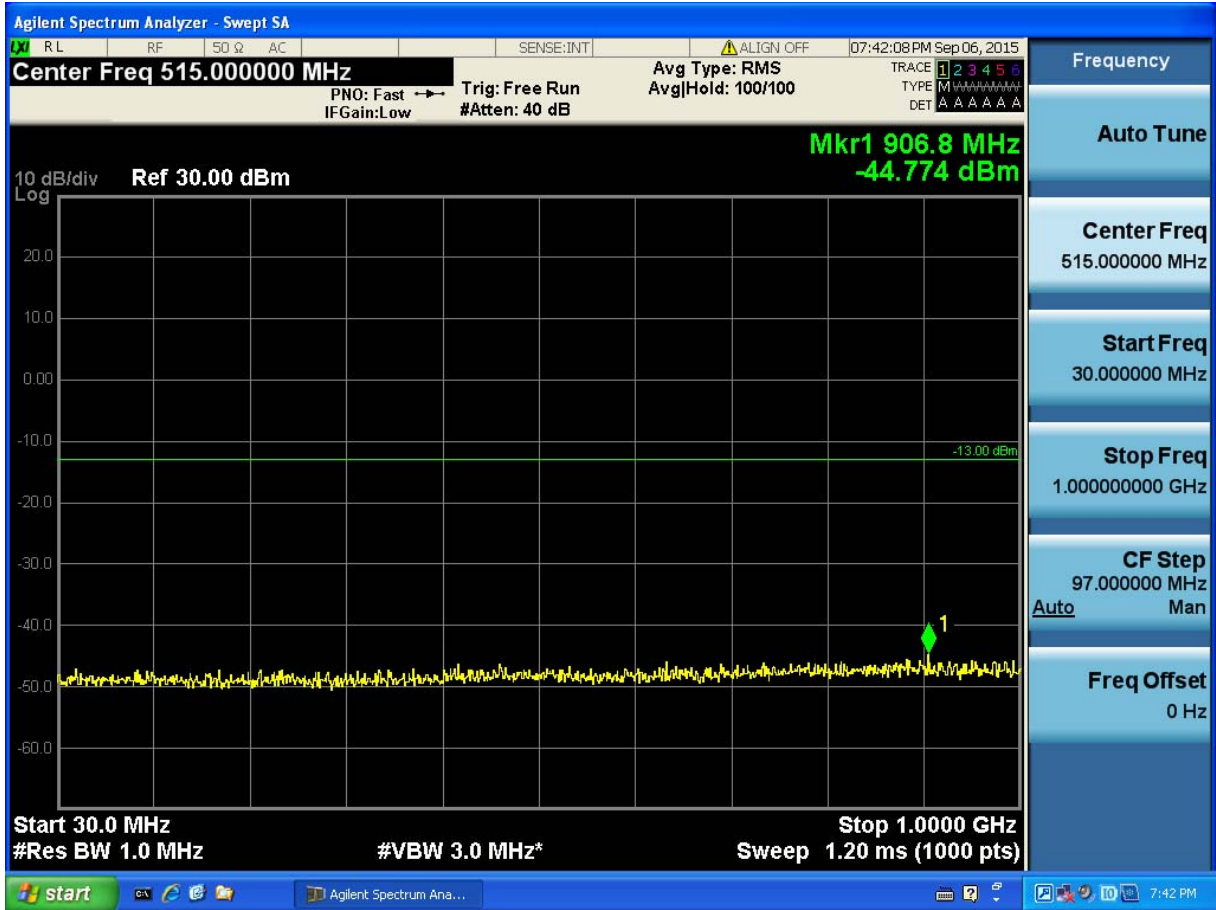

(Plot 4.5.2 C3: Channel 810: 1909.80MHz @ Traffic @ PCS1900)

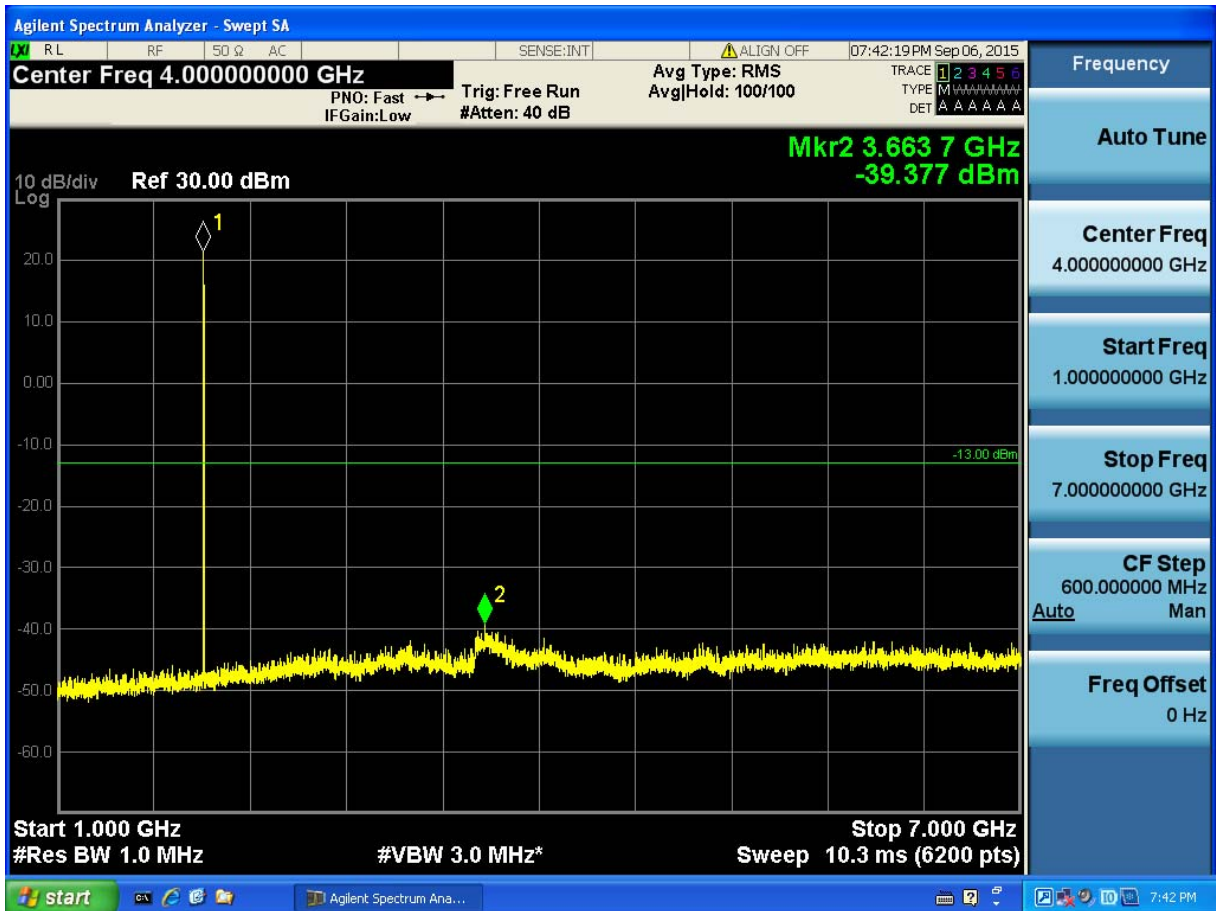

(Plot 4.5.2 C4: Channel 810: 1909.80MHz @ Traffic @ PCS1900)



(Plot 4.5.2 C5: Channel 810: 1909.80MHz @ Traffic @ PCS1900)



(Plot 4.5.2 C6: Channel 810: 1909.80MHz @ Traffic @ PCS1900)

4.6 Frequency Stability Test

TEST APPLICABLE

1. According to FCC Part 2 Section 2.1055 (a)(1), the frequency stability shall be measured with variation of ambient temperature from -30°C to +50°C centigrade.
2. According to FCC Part 2 Section 2.1055 (E) (2), for battery powered equipment, the frequency stability shall be measured with reducing primary supply voltage to the battery operating end point, which is specified by the manufacture.
3. Vary primary supply voltage from 85 to 115 percent of the nominal value for other than hand carried voltage equipment and the end voltage point was 3.40V.

TEST PROCEDURE

In order to measure the carrier frequency under the condition of AFC lock, it is necessary to make measurements with the EUT in a "call mode". This is accomplished with the use of R&S CMW500 DIGITAL RADIO COMMUNICATION TESTER.

1. Measure the carrier frequency at room temperature;
2. Subject the EUT to overnight soak at -30°C;
3. With the EUT, powered via nominal voltage, connected to the CMW500 and in a simulated call on middle channel of PCS 1900 and GSM850, measure the carrier frequency. These measurements should be made within 2 minutes of Powering up the EUT, to prevent significant self-warming;
4. Repeat the above measurements at 10°C increments from -30°C to +50°C. Allow at least 0.5 hours at each temperature, unpowered, before making measurements;
5. Remeasure carrier frequency at room temperature with nominal voltage. Vary supply voltage from minimum voltage to maximum voltage, in 0.1Volt increments remeasuring carrier frequency at each voltage. Pause at nominal voltage for 0.5 hours unpowered, to allow any self-heating to stabilize, before continuing;
6. Subject the EUT to overnight soak at +50°C;
7. With the EUT, powered via nominal voltage, connected to the CMW500 and in a simulated call on the centre channel, measure the carrier frequency. These measurements should be made within 2 minutes of Powering up the EUT, to prevent significant self-warming;
8. Repeat the above measurements at 10°C increments from +50°C to -30°C. Allow at least 0.5 hours at each temperature, unpowered, before making measurements;
9. At all temperature levels hold the temperature to +/- 0.5°C during the measurement procedure;

TEST CONFIGURATION

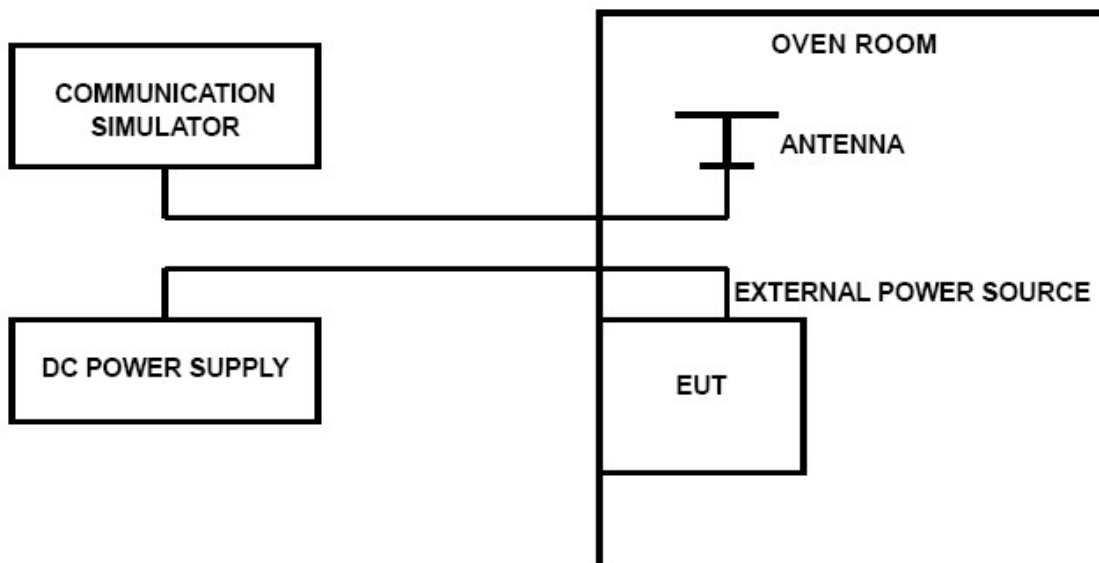

TEST LIMITS

For Hand carried battery powered equipment

According to the JTC standard the frequency stability of the carrier shall be accurate to within 0.1 ppm of the received frequency from the base station. This accuracy is sufficient to meet Sec. 24.235, Frequency Stability. The frequency stability shall be sufficient to ensure that the fundamental emission stays within the authorized

frequency block. As this transceiver is considered "Hand carried, battery powered equipment" Section 2.1055(d)(2) applies. This requires that the lower voltage for frequency stability testing be specified by the manufacturer. This transceiver is specified to operate with an input voltage of between 3.40VDC and 4.20VDC, with a nominal voltage of 3.70DC. Operation above or below these voltage limits is prohibited by transceiver software in order to prevent improper operation as well as to protect components from overstress. These voltages represent a tolerance of -10 % and +12.5 %. For the purposes of measuring frequency stability these voltage limits are to be used.

For equipment powered by primary supply voltage

According to the JTC standard the frequency stability of the carrier shall be accurate to within 0.1 ppm of the received frequency from the base station. This accuracy is sufficient to meet Sec. 24.235, Frequency Stability. The frequency stability shall be sufficient to ensure that the fundamental emission stays within the authorized frequency block. For this EUT section 2.1055(d)(1) applies. This requires varying primary supply voltage from 85 to 115 percent of the nominal value for other than hand carried battery equipment.

TEST RESULTS

GSM/TM1/GSM850					
DC Power	Temperature (°C)	Frequency error(Hz)	Frequency error(ppm)	Limit (ppm)	Verdict
3.40	25	-4.46	-0.01	2.50	PASS
3.80	25	-13.43	-0.02	2.50	PASS
4.20	25	-17.18	-0.02	2.50	PASS
3.80	-30	-17.56	-0.02	2.50	PASS
3.80	-20	-10.78	-0.01	2.50	PASS
3.80	-10	-15.05	-0.02	2.50	PASS
3.80	0	-11.56	-0.01	2.50	PASS
3.80	10	-12.66	-0.02	2.50	PASS
3.80	20	-13.24	-0.02	2.50	PASS
3.80	30	-12.01	-0.01	2.50	PASS
3.80	40	-10.20	-0.01	2.50	PASS
3.80	50	-18.14	-0.02	2.50	PASS

GSM/TM3/ EGPRS850					
DC Power	Temperature (°C)	Frequency error(Hz)	Frequency error(ppm)	Limit (ppm)	Verdict
3.40	25	-11.49	-0.01	2.50	PASS
3.80	25	-11.62	-0.01	2.50	PASS
4.20	25	-7.04	-0.01	2.50	PASS
3.80	-30	-15.88	-0.02	2.50	PASS
3.80	-20	-13.72	-0.02	2.50	PASS
3.80	-10	-10.72	-0.01	2.50	PASS
3.80	0	-12.24	-0.01	2.50	PASS
3.80	10	-12.30	-0.01	2.50	PASS
3.80	20	-11.20	-0.01	2.50	PASS
3.80	30	-9.94	-0.01	2.50	PASS
3.80	40	-12.24	-0.01	2.50	PASS
3.80	50	-9.62	-0.01	2.50	PASS

GSM/TM1/PCS1900					
DC Power	Temperature (°C)	Frequency error(Hz)	Frequency error(ppm)	Limit (ppm)	Verdict
3.40	25	-8.85	0.00	2.50	PASS
3.80	25	-9.30	-0.01	2.50	PASS
4.20	25	-6.72	0.00	2.50	PASS
3.80	-30	-6.52	0.00	2.50	PASS
3.80	-20	-3.87	0.00	2.50	PASS
3.80	-10	-0.84	0.00	2.50	PASS
3.80	0	2.52	0.00	2.50	PASS
3.80	10	-6.07	0.00	2.50	PASS
3.80	20	-6.72	0.00	2.50	PASS
3.80	30	-3.87	0.00	2.50	PASS
3.80	40	-5.68	0.00	2.50	PASS
3.80	50	0.52	0.00	2.50	PASS

GSM/TM3/ EGPRS1900					
DC Power	Temperature (°C)	Frequency error(Hz)	Frequency error(ppm)	Limit (ppm)	Verdict
3.40	25	-2.74	0.00	2.50	PASS
3.80	25	-3.23	0.00	2.50	PASS
4.20	25	-1.10	0.00	2.50	PASS
3.80	-30	3.94	0.00	2.50	PASS
3.80	-20	-0.71	0.00	2.50	PASS
3.80	-10	1.49	0.00	2.50	PASS
3.80	0	-5.97	0.00	2.50	PASS
3.80	10	-2.74	0.00	2.50	PASS
3.80	20	-5.59	0.00	2.50	PASS
3.80	30	-2.74	0.00	2.50	PASS
3.80	40	-3.23	0.00	2.50	PASS
3.80	50	-1.10	0.00	2.50	PASS

4.7 Peak-to-Average Ratio (PAR)

LIMIT

The Peak-to-Average Ratio (PAR) of the transmission may not exceed 13 dB.

TEST CONFIGURATION

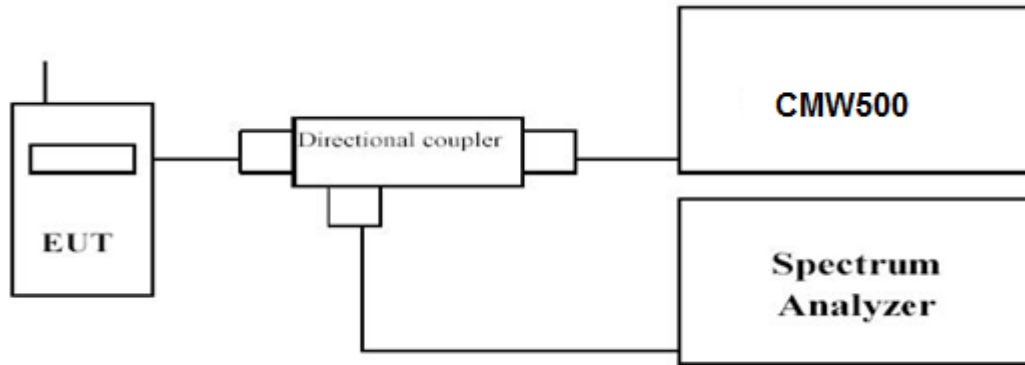

TEST PROCEDURE

Use spectrum to measure the total peak power and record as P_{Pk} . Use spectrum to measure the total average power and record as P_{Avg} . Both the peak and average power levels must be expressed in the same logarithmic units (e.g., dBm).

Determine the PAPR from:

$$PAPR \text{ (dB)} = P_{Pk} \text{ (dBm)} - P_{Avg} \text{ (dBm)}$$

TEST RESULTS

GSM/TM1/ PCS1900		GSM/TM3/EGPRS1900
Frequency (MHz)	Measured (dB)	Measured (dB)
1850.20	0.59	0.68
1880.00	0.78	0.75
1909.80	0.84	0.91

5 Test Setup Photos of the EUT

Please refer to separated files for Test Setup Photos of the EUT.

6 External Photos of the EUT

Please refer to separated files for External Photos of the EUT.

7 Internal Photos of the EUT

Please refer to separated files for Internal Photos of the EUT.

.....**End of Report**.....