



**FCC PART 22/24 TEST REPORT**

**FCC Part 22 /Part 24**

**Report Reference No.**..... : **MWR151101102**

**FCC ID**..... : **RQQHLT-L50SCM**

Compiled by  
( position+printed name+signature)..: File administrators Martin Ao

Supervised by  
( position+printed name+signature)..: Test Engineer Yuchao Wang

Approved by  
( position+printed name+signature)..: Manager Dixon Hao

Date of issue.....: Nov. 01, 2015

**Representative Laboratory Name** ..: **Maxwell International Co., Ltd.**

Address.....: Room 509, Hongfa center building, Baoan District, Shenzhen, Guangdong, China

**Testing Laboratory Name** .....: **Shenzhen CTL Testing Technology Co., Ltd.**

Address.....: Floor 1-A, Baisha Technology Park, No.3011, Shahexi Road, Nanshan District, Shenzhen, China 518055

**Applicant's name**.....: **HYUNDAI CORPORATION**

Address.....: 140-2, Kye-dong, Chongro-ku, Seoul, South Korea

**Test specification** ..... :

Standard .....: **FCC Part 22: PUBLIC MOBILE SERVICES**  
**FCC Part 24: PERSONAL COMMUNICATIONS SERVICES**  
**FCC Part 27: MISCELLANEOUS WIRELESS COMMUNICATIONS SERVICES**

TRF Originator.....: Maxwell International Co., Ltd.

**MAXWELL INTERNATIONAL CO., LTD. All rights reserved.**

This publication may be reproduced in whole or in part for non-commercial purposes as long as the MAXWELL INTERNATIONAL CO., LTD. as copyright owner and source of the material. MAXWELL INTERNATIONAL CO., LTD. takes no responsibility for and will not assume liability for damages resulting from the reader's interpretation of the reproduced material due to its placement and context.

**Test item description** .....: Mobile Phone

Trade Mark .....: HYUNDAI

**Manufacturer**.....: **Skycom Telecommunications Co., Limited**

Model/Type reference.....: L505

Listed Models .....: N/A

Ratings.....: DC 3.80V

Modulation .....: QPSK

Hardware version .....: WW818-MB-V0.5

Software version .....: HYUNDAI\_L505\_V4.0.3

Frequency.....: UMTS Band II/ UMTS Band IV/ UMTS Band V

Result.....: **PASS**

**TEST REPORT**

<b>Test Report No. :</b>	<b>MWR151101102</b>	Nov. 01, 2015
		Date of issue

Equipment under Test : Mobile Phone

Model /Type : L505

Listed Models : N/A

**Applicant** : **HYUNDAI CORPORATION**

Address : 140-2, Kye-dong, Chongro-ku, Seoul, South Korea

**Manufacturer** : **Skycom Telecommunications Co., Limited**

Address : Rm604, East Block, Shengtang Bldg., No.1, Tairan 9 Rd.,  
Chegongmiao, Futian District, Shenzhen, China

<b>Test Result:</b>	<b>PASS</b>
---------------------	-------------

The test report merely corresponds to the test sample.  
It is not permitted to copy extracts of these test result without the written permission of the test laboratory.

## Contents

<b><u>1</u></b>	<b><u>TEST STANDARDS.....</u></b>	<b><u>4</u></b>
<b><u>2</u></b>	<b><u>SUMMARY .....</u></b>	<b><u>5</u></b>
2.1	General Remarks	5
2.2	Product Description	5
2.3	Product Description	5
2.4	Equipment under Test	6
2.5	Short description of the Equipment under Test (EUT)	6
2.6	Internal Identification of AE used during the test	6
2.7	Normal Accessory setting	7
2.8	EUT configuration	7
2.9	Related Submittal(s) / Grant (s)	7
2.10	Modifications	7
2.11	General Test Conditions/Configurations	7
<b><u>3</u></b>	<b><u>TEST ENVIRONMENT.....</u></b>	<b><u>8</u></b>
3.1	Address of the test laboratory	8
3.2	Test Facility	8
3.3	Environmental conditions	8
3.4	Test Description	8
3.5	Equipments Used during the Test	10
<b><u>4</u></b>	<b><u>TEST CONDITIONS AND RESULTS.....</u></b>	<b><u>11</u></b>
4.1	Output Power	11
4.2	Radiated Spurious Emission	15
4.3	Occupied Bandwidth and Emission Bandwidth	19
4.4	Band Edge Compliance	23
4.5	Spurious Emission on Antenna Port	27
4.6	Frequency Stability Test	54
4.7	Peak-to-Average Ratio (PAR)	56
<b><u>5</u></b>	<b><u>TEST SETUP PHOTOS OF THE EUT .....</u></b>	<b><u>59</u></b>
<b><u>6</u></b>	<b><u>EXTERNAL PHOTOS OF THE EUT.....</u></b>	<b><u>59</u></b>
<b><u>7</u></b>	<b><u>INTERNAL PHOTOS OF THE EUT.....</u></b>	<b><u>59</u></b>

# **1 TEST STANDARDS**

The tests were performed according to following standards:

[FCC Part 22 \(10-1-12 Edition\)](#): PRIVATE LAND MOBILE RADIO SERVICES.

[FCC Part 24\(10-1-12 Edition\)](#): PUBLIC MOBILE SERVICES

[FCC Part 27\(10-1-12 Edition\)](#): MISCELLANEOUS WIRELESS COMMUNICATIONS SERVICES

[TIA/EIA 603 D June 2010](#): Land Mobile FM or PM Communications Equipment Measurement and Performance Standards.

[47 CFR FCC Part 15 Subpart B](#): - Unintentional Radiators

[FCC Part 2](#): FREQUENCY ALLOCA-TIONS AND RADIO TREATY MAT-TERS; GENERAL RULES AND REG-ULATIONS

[ANSI C63.4:2009](#): Methods of Measurement of Radio-Noise Emissions from Low-Voltage Electrical and Electronic Equipment in the Range of 9 kHz to 40 GHz

[FCCKDB971168D01](#) Power Meas License Digital Systems

## 2 SUMMARY

### 2.1 General Remarks

Date of receipt of test sample	:	Oct. 10, 2015
Testing commenced on	:	Oct. 11, 2015
Testing concluded on	:	Nov. 01, 2015

### 2.2 Product Description

### 2.3 Product Description

The **HYUNDAI CORPORATION**'s Model: L505 or the "EUT" as referred to in this report; more general information as follows, for more details, refer to the user's manual of the EUT.

Name of EUT	Mobile Phone
Model Number	L505
Modulation Type	GMSK for GSM/GPRS, 8-PSK for EDGE, QPSK for UMTS, QPSK, 16QAM for LTE
Antenna Type	Internal
UMTS Operation Frequency Band	Device supported UMTS FDD Band II/IV/V
WLAN FCC Operation frequency	IEEE 802.11b:2412-2462MHz IEEE 802.11g:2412-2462MHz IEEE 802.11n HT20:2412-2462MHz IEEE 802.11n HT40:2422-2452MHz
BT FCC Operation frequency	2402MHz-2480MHz
HSDPA Release Version	Release 10
HSUPA Release Version	Release 6
DC-HSUPA Release Version	Not Supported
WCDMA Release Version	R99
LTE Release Version	R8
LTE Operation Frequency Band	Device supported FDD band 2, FDD band 4, FDD band 7, FDD band 17
WLAN FCC Modulation Type	IEEE 802.11b: DSSS(CCK,DQPSK,DBPSK) IEEE 802.11g: OFDM(64QAM, 16QAM, QPSK, BPSK) IEEE 802.11n HT20: OFDM (64QAM, 16QAM, QPSK,BPSK) IEEE 802.11n HT40: OFDM (64QAM, 16QAM, QPSK,BPSK)
BT Modulation Type	GFSK,8DPSK, $\pi$ /4DQPSK(BT 3.0+EDR)
Hardware version	WW818-MB-V0.5
Software version	HYUNDAI_L505_V4.0.3
Android version	Android 4.4.2
GPS function	Supported
WLAN	Supported 802.11b/802.11g/802.11n
Bluetooth	Supported BT 4.0/BT 3.0+EDR
GSM/EDGE/GPRS	Supported GSM/GPRS/EDGE
GSM/EDGE/GPRS Power Class	GSM850:Power Class 4/ PCS1900:Power Class 1
GSM/EDGE/GPRS Operation Frequency	GSM850 :824.2MHz-848.8MHz/PCS1900:1850.2MHz-1909.8MHz
GSM/EDGE/GPRS Operation Frequency Band	GSM850/PCS1900/GPRS850/GPRS1900/EDGE850/EDGE1900
GSM Release Version	R99
GPRS/EDGE Multislot Class	GPRS/EDGE: Multi-slot Class 12
Extreme temp. Tolerance	-30°C to +50°C
Extreme vol. Limits	3.40VDC to 4.20VDC (nominal: 3.80VDC)
GPRS operation mode	Class B

## 2.4 Equipment under Test

### Power supply system utilised

Power supply voltage	:	<input type="radio"/> 120V / 60 Hz	<input type="radio"/> 115V / 60Hz
		<input type="radio"/> 12 V DC	<input type="radio"/> 24 V DC
		<input checked="" type="radio"/> Other (specified in blank below)	

DC 3.80V

### Test frequency list

Test Mode	TX/RX	RF Channel		
		Low(L)	Middle (M)	High (H)
WCDMA850	TX	Channel 4132	Channel 4182	Channel 4233
		826.4 MHz	836.4 MHz	846.6 MHz
	RX	Channel 4357	Channel 4407	Channel 4458
		871.4 MHz	881.4 MHz	891.6 MHz
WCDMA1900	TX	Channel 9262	Channel 9400	Channel 9538
		1852.4 MHz	1880.0 MHz	1907.6 MHz
WCDMA1900	RX	Channel 9662	Channel 9800	Channel 9938
		1932.4 MHz	1960.0 MHz	1987.6 MHz
WCDMA1700	TX	Channel1312	Channel1413	Channel1513
		1712.4MHz	1732.6MHz	1752.6MHz
	RX	Channel1537	Channel1638	Channel1738
		2112.4MHz	2132.6MHz	2152.6MHz

## 2.5 Short description of the Equipment under Test (EUT)

### 2.5.1 General Description

L505 is subscriber equipment in the WCDMA/GSM /LTE system. The HSPA/UMTS frequency band is Band II, Band IV and Band V, LTE frequency band is band 2, band 4, band 7,band 17; The GSM/GPRS/EDGE frequency band includes GSM850 and GSM900 and DCS1800 and PCS1900, but only Band II and Band V and GSM850 and PCS1900 bands test data included in this report. The Mobile Phone implements such functions as RF signal receiving/transmitting, HSPA/UMTS ,LTE and GSM/GPRS/EDGE protocol processing, voice, video MMS service, GPS and WIFI etc. Externally it provides micro SD card interface, earphone port (to provide voice service) and SIM card interface. It also provides Bluetooth module to synchronize data between a PC and the phone, or to use the built-in modem of the phone to access the Internet with a PC, or to exchange data with other Bluetooth devices.

NOTE: Unless otherwise noted in the report, the functional boards installed in the units shall be selected from the below list, but not means all the functional boards listed below shall be installed in one unit.

### 2.6 Internal Identification of AE used during the test

AE ID*	Description
AE1	Battery
AE2	Charger

AE1

Model: TPA-5950100UU

INPUT: 100-240V~ 50/60Hz 0.2A

OUTPUT: DC 5.0V 1.0A

\*AE ID: is used to identify the test sample in the lab internally.

## 2.7 Normal Accessory setting

Fully charged battery was used during the test.

## 2.8 EUT configuration

The following peripheral devices and interface cables were connected during the measurement:

- - supplied by the manufacturer
- - supplied by the lab

<input type="radio"/>	Power Cable	Length (m) :	/
		Shield :	/
		Detachable :	/
<input type="radio"/>	Multimeter	Manufacturer :	/
		Model No. :	/

## 2.9 Related Submittal(s) / Grant (s)

This submittal(s) (test report) is intended for **FCC ID: RQQHLT-L50SCM** filing to comply with FCC Part 22 and Part 24 Rules

## 2.10 Modifications

No modifications were implemented to meet testing criteria.

## 2.11 General Test Conditions/Configurations

### 2.11.1 Test Modes

NOTE: The test mode(s) are selected according to relevant radio technology specifications.

Test Mode	Test Modes Description
UMTS/TM1	WCDMA system, QPSK modulation
UMTS/TM2	HSDPA system, QPSK modulation
UMTS/TM3	HSUPA system, QPSK modulation

Note:

1. This EUT owns two SIM cards, after we perform the pretest for these two SIM cards; we found the SIM 1 is the worst case, so its result is recorded in this report.
2. As WCDMA, HSDPA and HSUPA with the same emission designator, test result recorded in this report at the worst case UMTS/TM1 only after exploratory scan.

### 2.11.2 Test Environment

Environment Parameter	Selected Values During Tests	
Relative Humidity	Ambient	
Temperature	TN	Ambient
Voltage	VL	3.4V
	VN	3.8V
	VH	4.2V

NOTE: VL=lower extreme test voltage VN=nominal voltage  
VH=upper extreme test voltage TN=normal temperature

### 3 TEST ENVIRONMENT

#### 3.1 Address of the test laboratory

##### Shenzhen CTL Testing Technology Co., Ltd.

Floor 1-A, Baisha Technology Park, No. 3011, Shahexi Road, Nanshan, Shenzhen 518055 China

There is one 3m semi-anechoic chamber and two line conducted labs for final test. The Test Sites meet the requirements in documents ANSI C63.4 and CISPR 22/EN 55022 requirements.

#### 3.2 Test Facility

The test facility is recognized, certified, or accredited by the following organizations:

The test facility is recognized, certified, or accredited by the following organizations:

##### IC Registration No.: 9618B

The 3m alternate test site of Shenzhen CTL Testing Technology Co., Ltd. EMC Laboratory has been registered by Certification and Engineer Bureau of Industry Canada for the performance of with Registration No.: 9618B on November 13, 2013.

##### FCC-Registration No.: 970318

Shenzhen CTL Testing Technology Co., Ltd. EMC Laboratory has been registered and fully described in a report filed with the (FCC) Federal Communications Commission. The acceptance letter from the FCC is maintained in our files. Registration 970318, December 19, 2013.

#### 3.3 Environmental conditions

During the measurement the environmental conditions were within the listed ranges:

Temperature:	15-35 ° C
Humidity:	30-60 %
Atmospheric pressure:	950-1050mbar

(1) expressed at approximately the 95% confidence level using a coverage factor of k=1.96.

#### 3.4 Test Description

##### 3.4.1 Cellular Band (824-849MHz paired with 869-894MHz)

Test Item	FCC Rule No.	Requirements	Verdict
Effective(Isotropic) Radiated Output Power	§2.1046, §22.913	FCC: ERP ≤ 7W.	Pass
Modulation Characteristics	§2.1047	Digital modulation	N/A
Bandwidth	§2.1049	OBW: No limit. EBW: No limit.	Pass
Band Edges Compliance	§2.1051, §22.917	≤-13dBm/1%*EBW, in 1MHz bands immediately outside and adjacent to The frequency block.	Pass
Spurious Emission at Antenna Terminals	§2.1051, §22.917	FCC: ≤ -13dBm/100kHz, from 9kHz to 10th harmonics but outside authorized operating frequency ranges.	Pass
Field Strength of Spurious Radiation	§2.1053, §22.917	FCC: ≤ -13dBm/100kHz.	Pass
Frequency Stability	§2.1055, §22.355	≤ ±2.5ppm.	Pass

NOTE 1: For the verdict, the "N/A" denotes "not applicable", the "N/T" de notes "not tested".



**3.4.2 PCS Band (1850-1915MHz paired with 1930-1995MHz)**

Test Item	FCC Rule No.	Requirements	Verdict
Effective(Isotropic) Radiated Output Power	§2.1046, §24.232	EIRP $\leq$ 2W	Pass
Peak-Average Ratio	§2.1046, §24.232	FCC:Limits $\leq$ 13dB	Pass
Modulation Characteristics	§2.1047	Digital modulation	N/A
Bandwidth	§2.1049	OBW: No limit. EBW: No limit.	Pass
Band Edges Compliance	§2.1051, §24.238	$\leq$ -13dBm/1%*EBW, In 1MHz bands immediately outside and adjacent to The frequency block.	Pass
Spurious Emission at Antenna Terminals	§2.1051, §24.238	$\leq$ -13dBm/1MHz, from 9kHz to10th harmonics but outside authorized Operating frequency ranges.	Pass
Field Strength of Spurious Radiation	§2.1053, §24.238	$\leq$ -13dBm/1MHz.	Pass
Frequency Stability	§2.1055, §24.235	FCC: within authorized frequency block.	Pass

NOTE 1: For the verdict, the "N/A" denotes "not applicable", the "N/T" de notes "not tested".

## Remark:

1. The measurement uncertainty is not included in the test result.

**3.4.3 AWS Band (1710-1755MHz pairedwith 2110-2155MHz)**

Test Item	FCC RuleNo.	Requirements	Verdict
Effective(Isotropic)Radiate dPowerOutputData	§2.1046, §27.50(d)	EIRP $\leq$ 1W;	Pass
Peak-AverageRatio	§2.1046, §27.50(d)	Limits $\leq$ 13dB	Pass
ModulationCharacteristics	§2.1047	Digitalmodulation	N/A
Bandwidth	§2.1049	OBW: Nolimit. EBW: Nolimit.	Pass
BandEdgesCompliance	§2.1051, §27.53(h)	$\leq$ -13dBm/1%*EBW,in1 MHzbandsimmediately outsideandadjacent to thefrequency block.	Pass
SpuriousEmissionatAntennaTerminals	§2.1051, §27.53(h)	$\leq$ -13dBm/1MHz, from9kHzto10thharmonicsbutoutsideauthorized operatingfrequency ranges.	Pass
Frequency Stability	§2.1055, §27.54	Withinauthorizedbands of operation/frequency block.	Pass
Radiatedspurious emission	§2.1053, §27.53(h)	$\leq$ -13dBm/1MHz.	Pass

NOTE 1: For the verdict, the "N/A" denotes "not applicable", the "N/T" de notes "not tested"

### 3.5 Equipments Used during the Test

Test Equipment	Manufacturer	Model No.	Serial No.	Calibration Date	Calibration Due Date
LISN	R&S	ENV216	3560.6550.12	2015/06/02	2016/06/01
LISN	R&S	ESH2-Z5	860014/010	2015/06/02	2016/06/01
Bilog Antenna	Sunol Sciences Corp.	JB1	A061713	2015/06/02	2016/06/01
EMI Test Receiver	R&S	ESCI	103710	2015/06/02	2016/06/01
Spectrum Analyzer	Agilent	N9030A	MY49430428	2015/05/21	2016/05/20
Controller	EM Electronics	Controller EM 1000	N/A	2015/05/21	2016/05/20
Horn Antenna	Sunol Sciences Corp.	DRH-118	A062013	2015/05/19	2016/05/18
Active Loop Antenna	SCHWARZBECK	FMZB1519	1519-037	2015/05/19	2016/05/18
Amplifier	Agilent	8349B	3008A02306	2015/05/19	2016/05/18
Amplifier	Agilent	8447D	2944A10176	2015/05/19	2016/05/18
Temperature/ Humidity Meter	Gangxing	CTH-608	02	2015/05/20	2016/05/19
High-Pass Filter	K&L	9SH10-2700/X12750-O/O	N/A	2015/05/20	2016/05/19
High-Pass Filter	K&L	41H10-1375/U12750-O/O	N/A	2015/05/20	2016/05/19
Coaxial Cables	HUBER+SUHNER	SUCOFLEX 104PEA-10M	10m	2015/06/02	2016/06/01
Coaxial Cables	HUBER+SUHNER	SUCOFLEX 104PEA-3M	3m	2015/06/02	2016/06/01
Coaxial Cables	HUBER+SUHNER	SUCOFLEX 104PEA-3M	3m	2015/06/02	2016/06/01
RF Cable	Megalon	RF-A303	N/A	2015/06/02	2016/06/01
Power Sensor	R&S	NRP-Z4	823.3618.03	2015.06.02	2016.06.01
Power Meter	R&S	NRVS	1020.1809.02	2015.06.02	2016.06.01

## 4 TEST CONDITIONS AND RESULTS

### 4.1 Output Power

#### TEST APPLICABLE

During the process of testing, the EUT was controlled via R&S Digital Radio Communication tester (CMW500) to ensure max power transmission and proper modulation. This result contains output power and EIRP measurements for the EUT. In all cases, output power is within the specified limits.

#### 4.1.1. Conducted Output Power

##### TEST CONFIGURATION

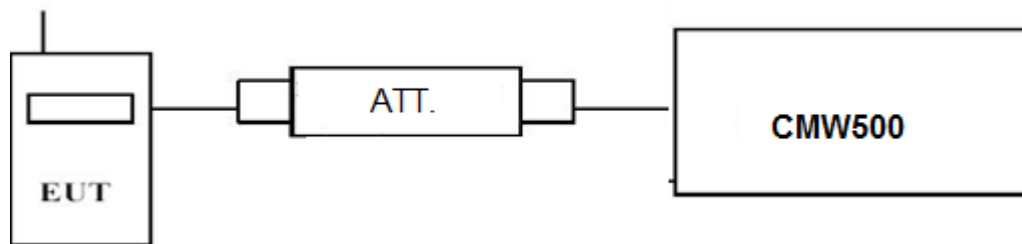

##### TEST PROCEDURE

###### **Conducted Power Measurement:**

- a) Place the EUT on a bench and set it in transmitting mode.
- b) Connect a low loss RF cable from the antenna port to a CMW500 by an Att.
- c) EUT Communicate with CMW500 then selects a channel for testing.
- d) Add a correction factor to the display CMW500, and then test.

##### TEST RESULTS

*See next page*

Test Mode	Test Channel	Burst Average Conducted power (dBm)		
		UMTS Band V	UMTS Band IV	UMTS Band II
UMTS/TM1	LCH	22.39	23.62	23.29
	MCH	22.86	23.44	23.39
	HCH	22.80	23.62	23.46
UMTS/TM2	LCH_SubTest-1	21.39	22.62	22.23
	LCH_SubTest-2	20.55	21.89	21.51
	LCH_SubTest-3	20.48	21.82	21.49
	LCH_SubTest-4	20.39	21.77	21.46
	MCH_SubTest-1	21.88	22.47	22.31
	MCH_SubTest-2	21.18	21.78	21.59
	MCH_SubTest-3	21.10	21.53	21.43
	MCH_SubTest-4	21.04	21.55	21.46
	HCH_SubTest-1	21.80	22.57	22.48
	HCH_SubTest-2	21.11	21.69	21.60
	HCH_SubTest-3	21.00	21.54	21.57
UMTS/TM3	LCH_SubTest-4	20.89	21.56	21.52
	LCH_SubTest-1	19.12	20.50	20.12
	LCH_SubTest-2	19.14	20.40	19.99
	LCH_SubTest-3	20.15	21.52	21.10
	LCH_SubTest-4	18.58	19.84	19.54
	LCH_SubTest-5	19.24	19.40	20.51
	MCH_SubTest-1	19.66	22.16	20.20
	MCH_SubTest-2	19.64	20.20	20.10
	MCH_SubTest-3	20.67	21.35	21.16
	MCH_SubTest-4	19.07	19.69	19.56
	MCH_SubTest-5	20.10	21.74	20.61
	HCH_SubTest-1	19.59	20.46	20.28
	HCH_SubTest-2	19.58	20.32	20.26
	HCH_SubTest-3	20.62	21.46	21.33
HCH_SubTest-4	19.01	19.78	19.71	
HCH_SubTest-5	20.03	20.58	20.37	

## 4.1.1 Radiated Output Power

### TEST DESCRIPTION

This is the test for the maximum radiated power from the EUT.

Rule Part 24.232(c) specifies, "Mobile/portable stations are limited to 2 watts e.i.r.p. Peak power" and 24.232(e) specifies that "Peak transmit power must be measured over any interval of continuous transmission using instrumentation calibrated in terms of an rms-equivalent voltage." Rule Part 22.913(a) specifies "The ERP of mobile transmitters and auxiliary test transmitters must not exceed 7 Watts."

Per Part 27.50(d) (4) specifies, Fixed, mobile, and portable (hand-held) stations operating in the 1710-1755MHz band are limited to 1W EIRP. Fixed stations operating in this band are limited to a maximum antenna height of 10 meters above ground. Mobile and portable stations operating in this band must employ a means for limiting power to the minimum necessary for successful communications.

### TEST CONFIGURATION

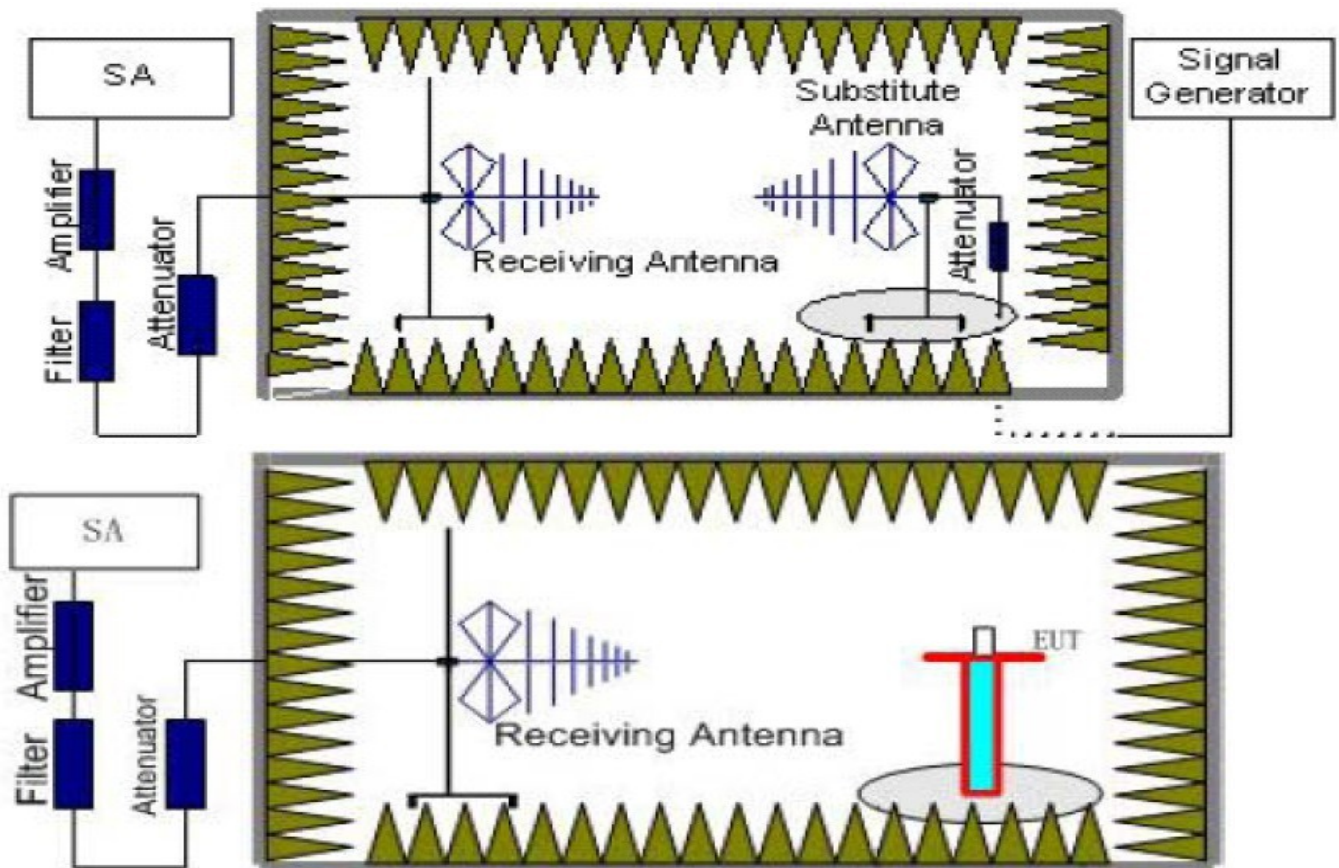

### TEST PROCEDURE

1. EUT was placed on a 0.80 meter high non-conductive stand at a 3 meter test distance from the receive antenna. A receiving antenna was placed on the antenna mast 3 meters from the EUT for emission measurements. The height of receiving antenna is 0.80m. Detected emissions were maximized at each frequency by rotating the EUT through 360° and adjusting the receiving antenna polarization. The radiated emission measurements of all transmit frequencies in three channels (High, Middle, Low) were measured with peak detector.
2. A log-periodic antenna or double-ridged waveguide horn antenna shall be substituted in place of the EUT. The log-periodic antenna will be driven by a signal generator and the level will be adjusted till the same power value on the spectrum analyzer or receiver. The level of the spurious emissions can be calculated through the level of the signal generator, cable loss, the gain of the substitution antenna and the reading of the spectrum analyzer or receiver.
3. The EUT is then put into continuously transmitting mode at its maximum power level during the test. Set Test Receiver or Spectrum RBW=10MHz, VBW=10MHz, And the maximum value of the receiver should be recorded as ( $P_r$ ).
4. The EUT shall be replaced by a substitution antenna. In the chamber, an substitution antenna for the frequency band of interest is placed at the reference point of the chamber. An RF Signal source for the

frequency band of interest is connected to the substitution antenna with a cable that has been constructed to not interfere with the radiation pattern of the antenna. A power ( $P_{Mea}$ ) is applied to the input of the substitution antenna, and adjust the level of the signal generator output until the value of the receiver reach the previously recorded ( $P_r$ ). The power of signal source ( $P_{Mea}$ ) is recorded. The test should be performed by rotating the test item and adjusting the receiving antenna polarization.

5. A amplifier should be connected to the Signal Source output port. And the cable should be connect between the Amplifier and the Substitution Antenna. The cable loss ( $P_{cl}$ ), the Substitution Antenna Gain ( $G_a$ ) and the Amplifier Gain ( $P_{Ag}$ ) should be recorded after test.

The measurement results are obtained as described below:

$$\text{Power(EIRP)} = P_{Mea} - P_{cl} + G_a$$

We used SMF100A microwave signal generator which signal level can up to 33dBm, so we not used power Amplifier for substitution test; The measurement results are amend as described below:

$$\text{Power(EIRP)} = P_{Mea} - P_{cl} + G_a$$

6. This value is EIRP since the measurement is calibrated using an antenna of known gain (2.15 dBi) and known input power.
7. ERP can be calculated from EIRP by subtracting the gain of the dipole,  $ERP = EIRP - 2.15\text{dBi}$ .

### TEST LIMIT

According to 22.913(a), 24.232(c) and 27.50(d) (4), the ERP(EIRP) should be not exceeding following table limits:

	<b>Burst Average EIRP</b>
UMTS Band II	33dBm (2W)
	<b>Burst Average EIRP</b>
UMTS Band IV	30dBm (1W)
	<b>Burst Average ERP</b>
UMTS Band V	38.45dBm (7W)

### TEST RESULTS

Remark:

1. We were tested all Configuration refer 3GPP TS134 121.
2.  $EIRP = P_{Mea}(\text{dBm}) - P_{cl}(\text{dB}) + P_{Ag}(\text{dB}) + G_a(\text{dBi})$
3.  $ERP = EIRP - 2.15\text{dBi}$  as EIRP by subtracting the gain of the dipole.

#### UMTS/TM1/UMTS Band II

Frequency (MHz)	$P_{Mea}$ (dBm)	$P_{cl}$ (dB)	$G_a$ Antenna Gain(dB)	$P_{Ag}$ (dB)	EIRP (dBm)	Limit (dBm)	Margin (dB)	Polarization
1852.4	-19.84	3.41	10.24	33.60	20.59	33.01	12.42	H
1880.0	-19.61	3.49	10.24	33.60	<b>20.74</b>	33.01	12.27	H
1907.6	-20.74	3.55	10.23	33.60	19.54	33.01	13.47	H

#### UMTS/TM1/UMTS Band V

Frequency (MHz)	$P_{Mea}$ (dBm)	$P_{cl}$ (dB)	$G_a$ Antenna Gain(dB)	Correction (dB)	$P_{Ag}$ (dB)	ERP (dBm)	Limit (dBm)	Margin (dB)	Polarization
826.40	-23.01	2.42	8.45	2.15	36.82	17.69	38.45	20.76	V
836.60	-22.79	2.46	8.45	2.15	36.82	<b>17.87</b>	38.45	20.58	V
846.60	-23.35	2.53	8.36	2.15	36.82	17.15	38.45	21.30	V

#### UMTS/TM1/UMTS Band IV

Frequency (MHz)	$P_{Mea}$ (dBm)	$P_{cl}$ (dB)	$G_a$ Antenna Gain(dB)	$P_{Ag}$ (dB)	EIRP (dBm)	Limit (dBm)	Margin (dB)	Polarization
1712.4	-25.19	3.06	9.68	34.80	16.23	30.00	13.77	H
1732.6	-24.26	3.17	9.68	34.80	<b>17.05</b>	30.00	12.95	H
1752.6	-24.59	3.22	9.75	34.80	16.74	30.00	13.26	H

## 4.2 Radiated Spurious Emission

### TEST APPLICABLE

According to the TIA/EIA 603D:2010 test method, The Receiver or Spectrum was scanned from 9 KHz to the 10<sup>th</sup> harmonic of the highest frequency generated within the equipment, which is the transmitted carrier that can be as high as 1910 MHz The resolution bandwidth is set as outlined in Part 24.238, Part 22.917 and Part 27.54. The spectrum is scanned with the mobile station transmitting at carrier frequencies that pertain to low, mid and high channels of WCDMA Band II WCDMA Band IV and WCDMA Band V.

### TEST CONFIGURATION

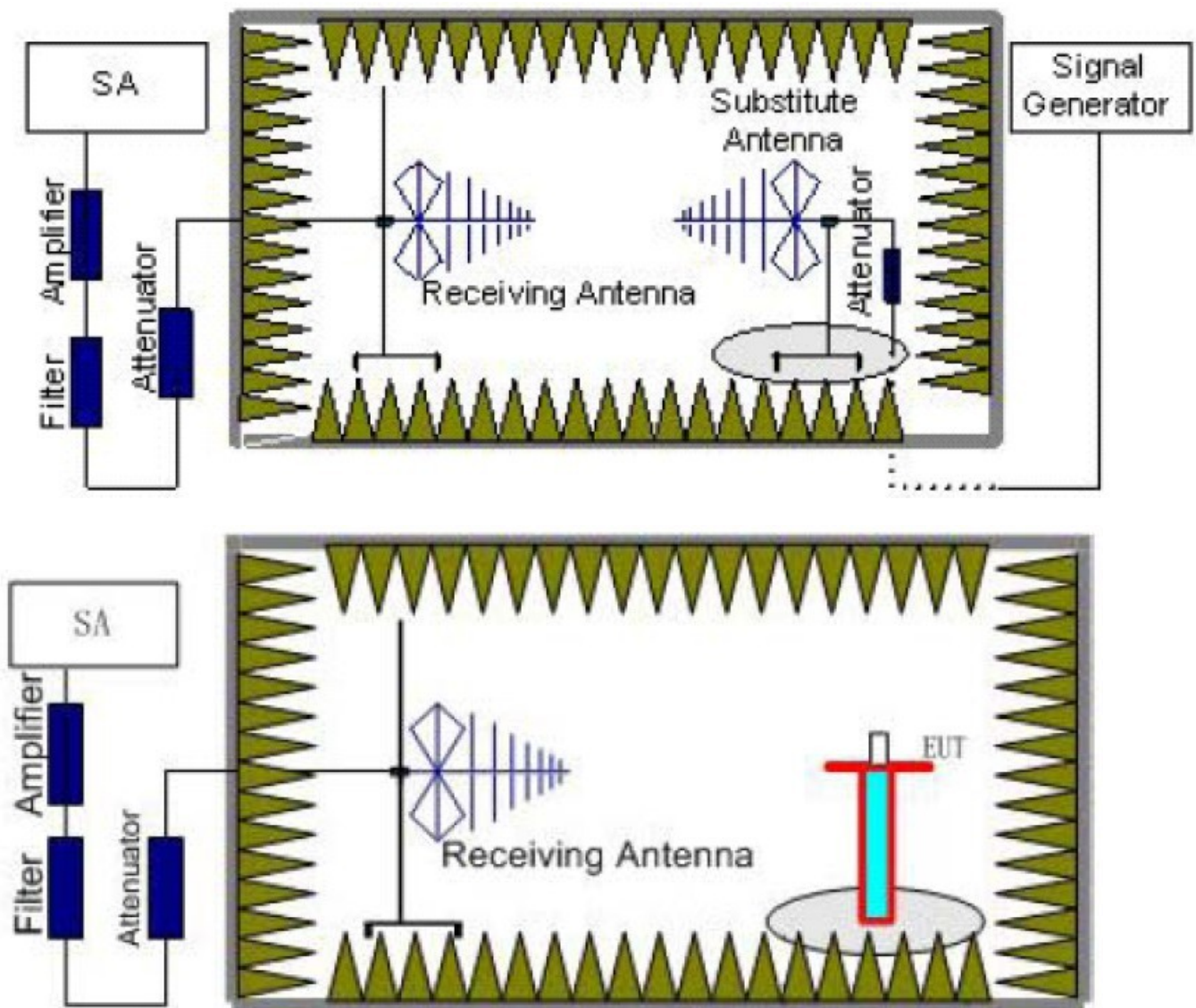

### TEST PROCEDURE

1. EUT was placed on a 0.80 meter high non-conductive stand at a 3 meter test distance from the receive antenna. A receiving antenna was placed on the antenna mast 3 meters from the EUT for emission measurements. The height of receiving antenna is 0.80m. Detected emissions were maximized at each frequency by rotating the EUT through 360° and adjusting the receiving antenna polarization. The radiated emission measurements of all transmit frequencies in three channels (High, Middle, Low) were measured with peak detector.
2. A log-periodic antenna or double-ridged waveguide horn antenna shall be substituted in place of the EUT. The log-periodic antenna will be driven by a signal generator and the level will be adjusted till the same power value on the spectrum analyzer or receiver. The level of the spurious emissions can be calculated through the level of the signal generator, cable loss, the gain of the substitution antenna and the reading of the spectrum analyzer or receiver.

3. The EUT is then put into continuously transmitting mode at its maximum power level during the test. Set Test Receiver or Spectrum RBW=1MHz, VBW=3MHz, And the maximum value of the receiver should be recorded as ( $P_r$ ).
4. The EUT shall be replaced by a substitution antenna. In the chamber, an substitution antenna for the frequency band of interest is placed at the reference point of the chamber. An RF Signal source for the frequency band of interest is connected to the substitution antenna with a cable that has been constructed to not interfere with the radiation pattern of the antenna. A power ( $P_{Mea}$ ) is applied to the input of the substitution antenna, and adjust the level of the signal generator output until the value of the receiver reach the previously recorded ( $P_r$ ). The power of signal source ( $P_{Mea}$ ) is recorded. The test should be performed by rotating the test item and adjusting the receiving antenna polarization.
5. A amplifier should be connected to the Signal Source output port. And the cable should be connect between the Amplifier and the Substitution Antenna. The cable loss ( $P_{cl}$ ), the Substitution Antenna Gain ( $G_a$ ) and the Amplifier Gain ( $P_{Ag}$ ) should be recorded after test. The measurement results are obtained as described below:  
Power(EIRP)= $P_{Mea} - P_{Ag} - P_{cl} + G_a$
6. This value is EIRP since the measurement is calibrated using an antenna of known gain (2.15 dBi) and known input power.
7. ERP can be calculated from EIRP by subtracting the gain of the dipole, ERP = EIRP -2.15dBi.
8. In order to make sure test results more clearly, we set frequency range and sweep time for difference frequency range as follows table:

Working Frequency	Subrange (GHz)	RBW	VBW	Sweep time (s)
UMTS/TM1/ WCDMA Band V	0.00009~0.15	1KHz	3KHz	30
	0.00015~0.03	10KHz	30KHz	10
	0.03~1	100KHz	300KHz	10
	1~2	1 MHz	3 MHz	2
	2~5	1 MHz	3 MHz	3
	5~8	1 MHz	3 MHz	3
	8~10	1 MHz	3 MHz	3
UMTS/TM1/ WCDMA Band II	0.00009~0.15	1KHz	3KHz	30
	0.00015~0.03	10KHz	30KHz	10
	0.03~1	100KHz	300KHz	10
	1~2	1 MHz	3 MHz	2
	2~5	1 MHz	3 MHz	3
	5~8	1 MHz	3 MHz	3
	8~11	1 MHz	3 MHz	3
	11~14	1 MHz	3 MHz	3
	14~18	1 MHz	3 MHz	3
UMTS/TM1/ WCDMA Band IV	0.00009~0.15	1KHz	3KHz	30
	0.00015~0.03	10KHz	30KHz	10
	0.03~1	100KHz	300KHz	10
	1~2	1 MHz	3 MHz	2
	2~5	1 MHz	3 MHz	3
	5~8	1 MHz	3 MHz	3
	8~11	1 MHz	3 MHz	3
	11~14	1 MHz	3 MHz	3
	14~18	1 MHz	3 MHz	3

### TEST LIMITS

According to 24.238, 22.917 and 27.54 specify that the power of any emission outside of the authorized operating frequency ranges must be attenuated below the transmitting power ( $P$ ) by a factor of at least  $43 + 10 \log(P)$  dB.

The specification that emissions shall be attenuated below the transmitter power ( $P$ ) by at least  $43 + 10 \log(P)$  dB, translates in the relevant power range (1 to 0.001 W) to -13 dBm. At 1 W the specified minimum attenuation becomes 43 dB and relative to a 30 dBm (1 W) carrier becomes a limit of -13 dBm. At 0.001 W (0 dBm) the minimum attenuation is 13 dB, which again yields a limit of -13 dBm. In this way a translation of the specification from relative to absolute terms is carried out.



Frequency	Channel	Frequency Range	Verdict
UMTS/TM1/ WCDMA Band V	Low	9KHz-10GHz	PASS
	Middle	9KHz -10GHz	PASS
	High	9KHz -10GHz	PASS
UMTS/TM1/ WCDMA Band II	Low	9KHz -20GHz	PASS
	Middle	9KHz -20GHz	PASS
	High	9KHz -20GHz	PASS
UMTS/TM1/ WCDMA Band IV	Low	9KHz -18GHz	PASS
	Middle	9KHz -48GHz	PASS
	High	9KHz -48GHz	PASS

## TEST RESULTS

Remark:

1. We were tested all Configuration refer 3GPP TS134 121.
2.  $EIRP = P_{Mea}(dBm) - P_{cl}(dB) + P_{Ag}(dB) + G_a(dBi)$
3.  $ERP = EIRP - 2.15dBi$  as EIRP by subtracting the gain of the dipole.

### UMTS/TM1/ WCDMA Band II \_ Low Channel

Frequency (MHz)	P <sub>Mea</sub> (dBm)	P <sub>cl</sub> (dB)	Diatance	Ga Antenna Gain(dB)	Peak EIRP (dBm)	Limit (dBm)	Margin (dB)	Polarization
3704.8	-43.21	4.39	3.00	12.34	-35.26	-13.00	22.26	H
5557.2	-45.62	5.31	3.00	13.52	-37.41	-13.00	24.41	H
3704.8	-40.31	4.39	3.00	12.34	-32.36	-13.00	19.36	V
5557.2	-43.62	5.31	3.00	13.52	-35.41	-13.00	22.41	V

### UMTS/TM1/ WCDMA Band II \_ Middle Channel

Frequency (MHz)	P <sub>Mea</sub> (dBm)	P <sub>cl</sub> (dB)	Diatance	Ga Antenna Gain(dB)	EIRP (dBm)	Limit (dBm)	Margin (dB)	Polarization
3760.0	-41.38	4.41	3.00	12.34	-33.45	-13.00	20.45	H
5640.0	-48.34	5.38	3.00	13.58	-40.14	-13.00	27.14	H
3760.0	-39.18	4.41	3.00	12.34	-31.25	-13.00	18.25	V
5640.0	-47.72	5.38	3.00	13.58	-39.52	-13.00	26.52	V

### UMTS/TM1/ WCDMA Band II \_ High Channel

Frequency (MHz)	P <sub>Mea</sub> (dBm)	P <sub>cl</sub> (dB)	Diatance	Ga Antenna Gain(dB)	EIRP (dBm)	Limit (dBm)	Margin (dB)	Polarization
3815.2	-43.49	4.45	3.00	12.45	-35.49	-13.00	22.49	H
5722.8	-46.75	5.47	3.00	13.66	-38.56	-13.00	25.56	H
3815.2	-42.78	4.45	3.00	12.45	-34.78	-13.00	21.78	V
5722.8	-44.44	5.48	3.00	13.66	-36.26	-13.00	23.26	V

### UMTS/TM1/ WCDMA Band V \_ Low Channel

Frequency (MHz)	P <sub>Mea</sub> (dBm)	P <sub>cl</sub> (dB)	Diatance	Ga Antenna Gain(dB)	Peak EIRP (dBm)	Limit (dBm)	Margin (dB)	Polarization
1652.8	-38.84	3.00	3.00	9.58	-32.26	-13.00	19.26	H
2479.2	-47.94	3.03	3.00	10.72	-40.25	-13.00	27.25	H
1652.8	-38.56	3.00	3.00	9.68	-31.88	-13.00	18.88	V
2479.2	-46.33	3.03	3.00	10.72	-38.64	-13.00	25.64	V

### UMTS/TM1/ WCDMA Band V \_ Middle Channel

Frequency (MHz)	P <sub>Mea</sub> (dBm)	P <sub>cl</sub> (dB)	Diatance	Ga Antenna Gain(dB)	EIRP (dBm)	Limit (dBm)	Margin (dB)	Polarization
1672.8	-38.45	3.00	3.00	9.58	-31.87	-13.00	18.87	H
2509.2	-47.32	3.03	3.00	10.72	-39.63	-13.00	26.63	H
1672.8	-36.04	3.00	3.00	9.68	-29.36	-13.00	16.36	V
2509.2	-43.10	3.03	3.00	10.72	-35.41	-13.00	22.41	V

## UMTS/TM1/ WCDMA Band V \_ High Channel

Frequency (MHz)	P <sub>Mea</sub> (dBm)	P <sub>cl</sub> (dB)	Diatance	Ga Antenna Gain(dB)	EIRP (dBm)	Limit (dBm)	Margin (dB)	Polarization
1693.2	-37.84	3.00	3.00	9.58	-31.26	-13.00	18.26	H
2539.8	-49.24	3.03	3.00	10.72	-41.55	-13.00	28.55	H
1693.2	-37.01	3.00	3.00	9.68	-30.33	-13.00	17.33	V
2539.8	-46.38	3.03	3.00	10.72	-38.69	-13.00	25.69	V

### 4.3 Occupied Bandwidth and Emission Bandwidth

#### TEST APPLICABLE

Similar to conducted emissions; occupied bandwidth measurements are only provided for selected frequencies in order to reduce the amount of submitted data. Data were taken at the extreme and mid frequencies of WCDMA Band II, WCDMA IV and WCDMA band V. The table below lists the measured 99% Bandwidth and -26dBc Bandwidth.

#### TEST CONFIGURATION

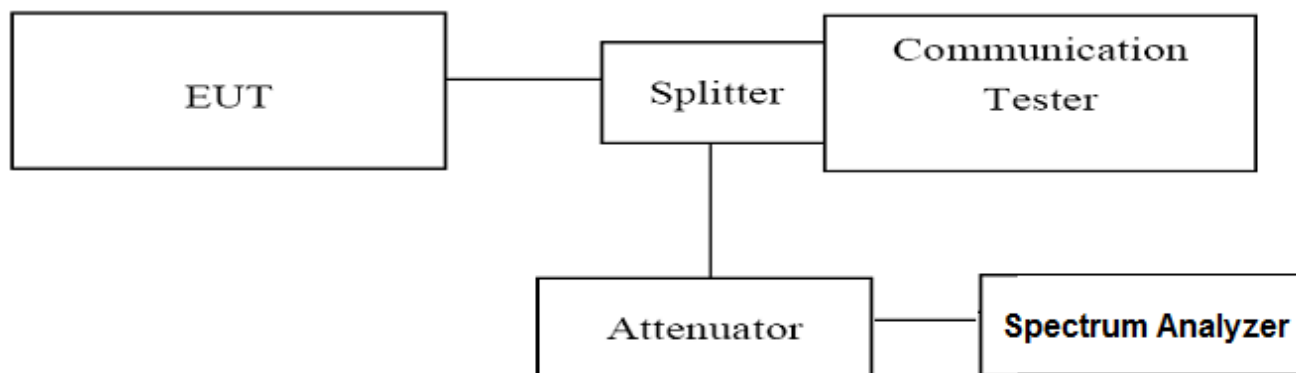

#### TEST PROCEDURE

1. The EUT was set up for the max output power with pseudo random data modulation;
2. The Occupied bandwidth and Emission Bandwidth were measured with Agilent Spectrum Analyzer N9020A (peak);
3. Set RBW=100KHz,VBW=30KHz,Span=10MHz,SWT=1.267ms;
4. Set SPA Max hold and View, Set 99% Occupied Bandwidth/ Set -26dBc Occupied Bandwidth
5. These measurements were done at 3 frequencies for WCDMA band II/IV/V. (low, middle and high of operational frequency range).

#### TEST RESULTS

UMTS/TM1/ WCDMA Band II				
Channel Number	Frequency (MHz)	Occupied Bandwidth (99% BW) ( kHz)	Emission Bandwidth (26 dBc BW) ( kHz)	Verdict
9262	1852.4	4210.0	4845	PASS
9400	1880.0	4200.5	4848	PASS
9538	1907.6	4214.5	4842	PASS

UMTS/TM1/ WCDMA Band IV				
Channel Number	Frequency (MHz)	Occupied Bandwidth (99% BW) ( kHz)	Emission Bandwidth (26 dBc BW) ( kHz)	Verdict
1312	1712.4	4201.0	4851	PASS
1413	1732.6	4214.8	4847	PASS
1513	1752.6	4208.1	4835	PASS

UMTS/TM1/ WCDMA Band V				
Channel Number	Frequency (MHz)	Occupied Bandwidth (99% BW) ( kHz)	Emission Bandwidth (26 dBc BW) ( kHz)	Verdict
4132	826.40	4203.5	4878	PASS
4183	836.60	4206.5	4824	PASS
4233	846.60	4210.2	4840	PASS

UMTS/TM1/ WCDMA Band II

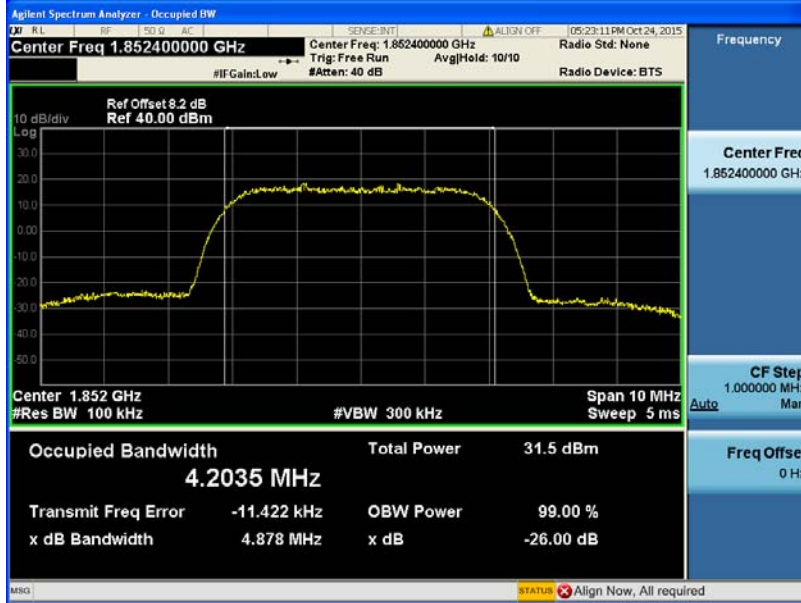

Channel 9262

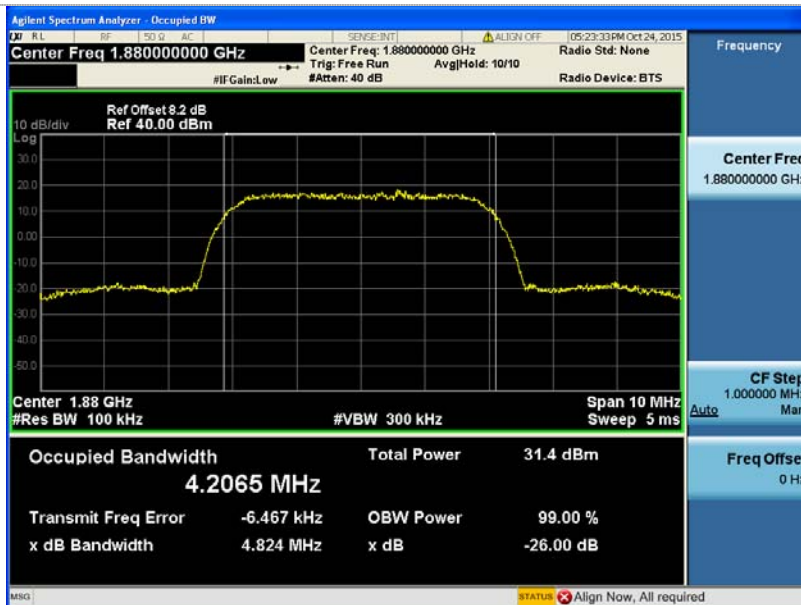

Channel 9400

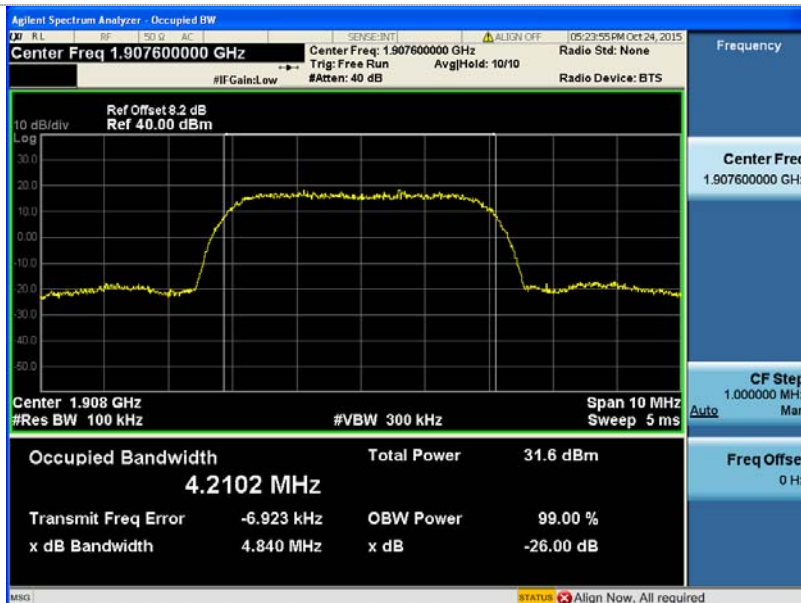

Channel 9538

UMTS/TM1/ WCDMA Band IV

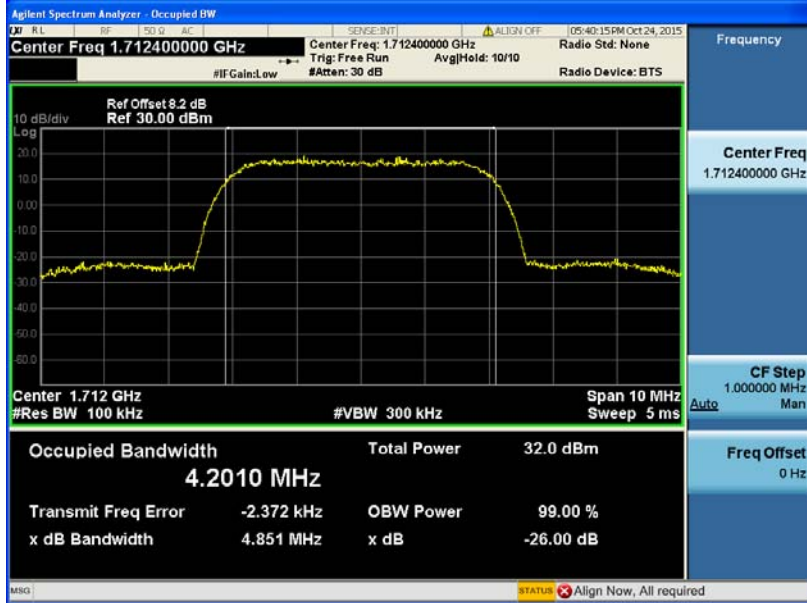

Channel1312

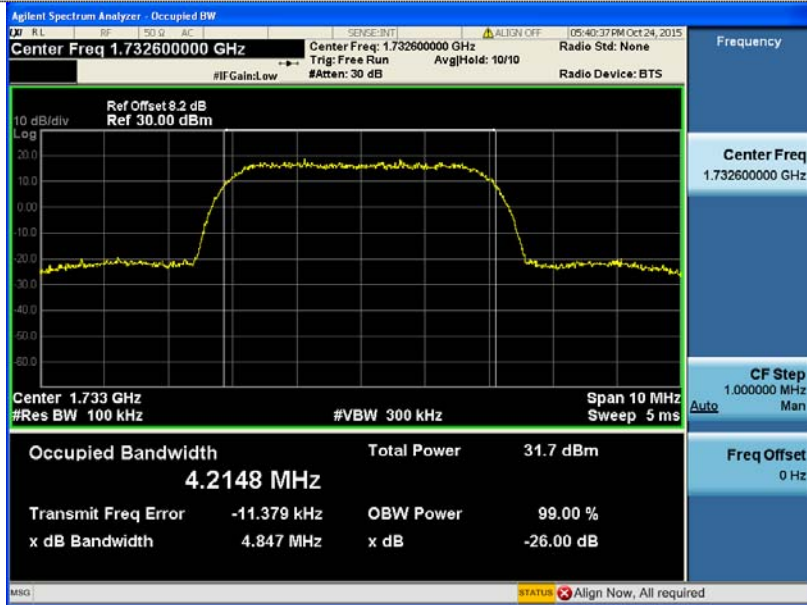

Channel 1413



Channel 1513

UMTS/TM1/ WCDMA Band V

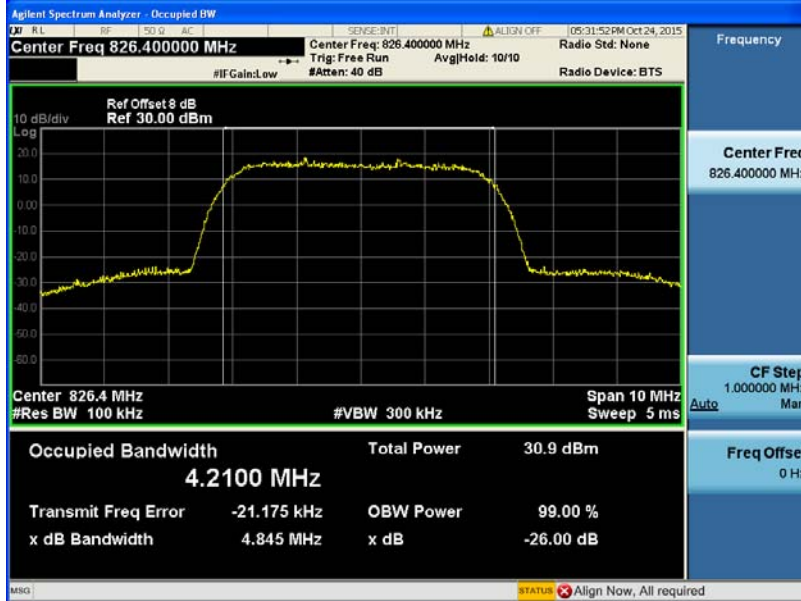

Channel 4132

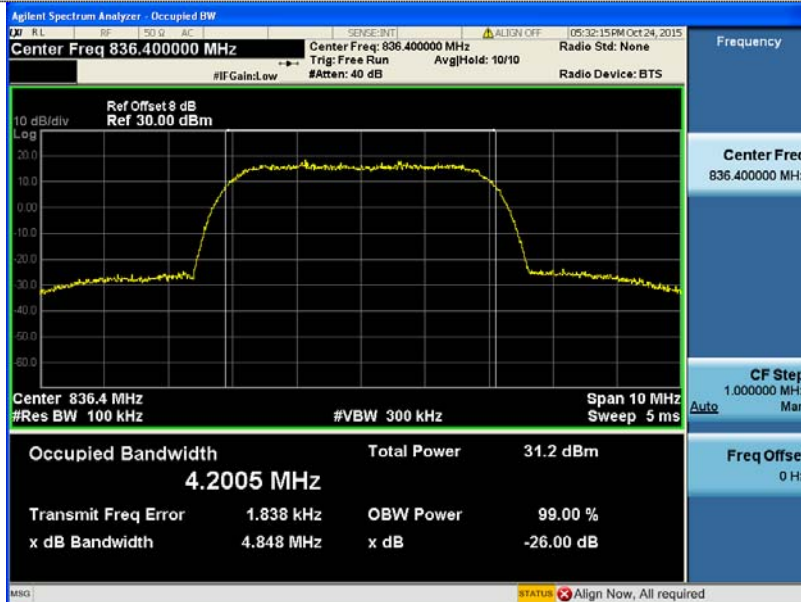

Channel 4183

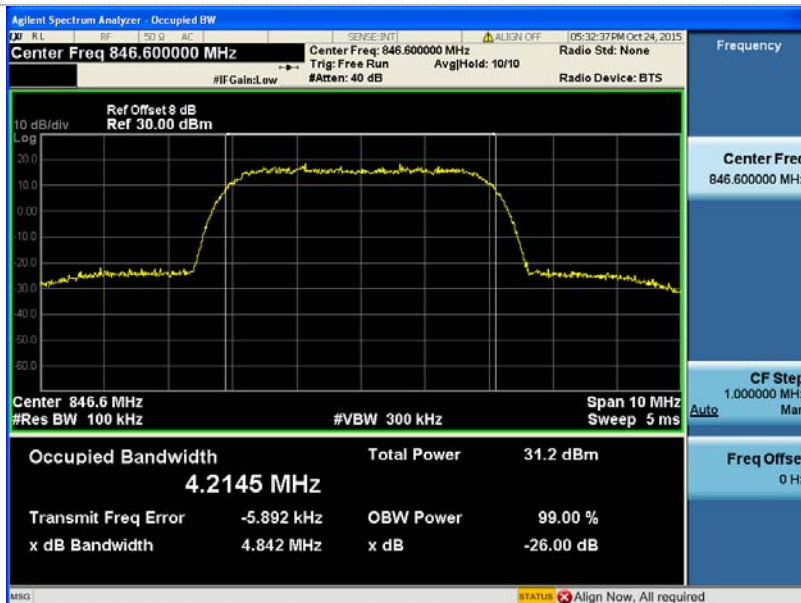

Channel 4233

## 4.4 Band Edge Compliance

### TEST APPLICABLE

During the process of testing, the EUT was controlled via Agilent Digital Radio Communication tester (8960) to ensure max power transmission and proper modulation.

### TEST CONFIGURATION

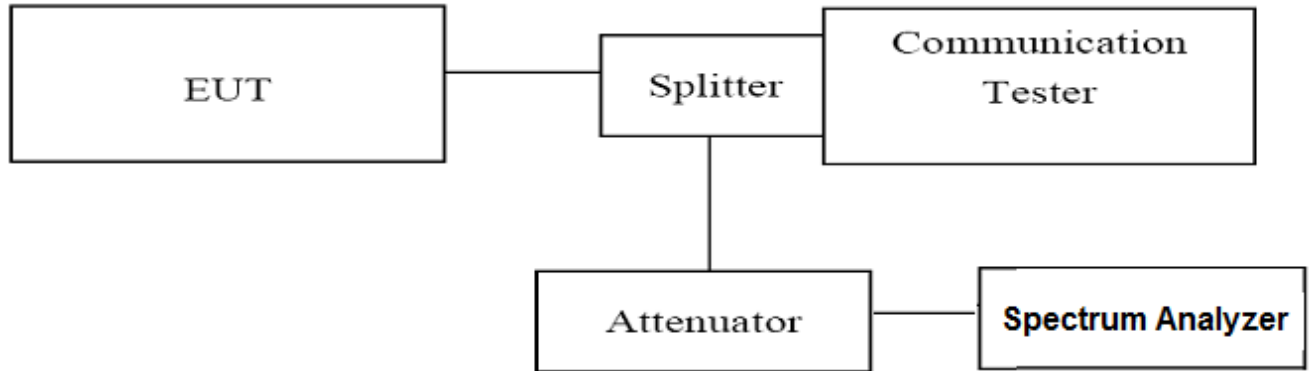

### TEST PROCEDURE

1. The EUT was set up for the max output power with pseudo random data modulation;
  2. The power was measured with Agilent Spectrum Analyzer N9020A;
  3. Set RBW=51KHz,VBW=200KHz,Span=5MHz,SWT=1ms,Detector: RMS;
- These measurements were done at 2 frequencies for WCDMA Band II/IV/V. (low and high of operational frequency range).

### TEST RESULTS

UMTS/TM1/WCDMA Band II						
Channel Number	Frequency (MHz)	Measurement Results		Limit (dBm)	Refer to Plot	Verdict
		Frequency (MHz)	Values (dBm)			
9262	1852.4	1849.875	-20.755	-13.00	Plot 4.4.1 A	PASS
9538	1907.6	1910.170	-19.987	-13.00	Plot 4.4.1 B	PASS

UMTS/TM1/WCDMA Band IV						
Channel Number	Frequency (MHz)	Measurement Results		Limit (dBm)	Refer to Plot	Verdict
		Frequency (MHz)	Values (dBm)			
1312	1712.4	1709.836	-21.213	-13.00	Plot 4.4.2 A	PASS
1513	1752.6	1755.171	-20.021	-13.00	Plot 4.4.2 B	PASS

UMTS/TM1/WCDMA Band V						
Channel Number	Frequency (MHz)	Measurement Results		Limit (dBm)	Refer to Plot	Verdict
		Frequency (MHz)	Values (dBm)			
4132	826.40	823.993	-19.389	-13.00	Plot 4.4.3 A	PASS
4233	846.60	849.001	-21.120	-13.00	Plot 4.4.3 B	PASS



(Plot 4.5.1 A: Channel 9262: 1852.4MHz WCDMA Band II)



(Plot 4.5.1 B: Channel 9538: 1907.6MHz WCDMA Band II)





(Plot 4.5.2 A: Channel 1312: 1712.4MHz WCDMA Band IV)



(Plot 4.5.2 B: Channel 1513: 1752.6MHz WCDMA Band II)

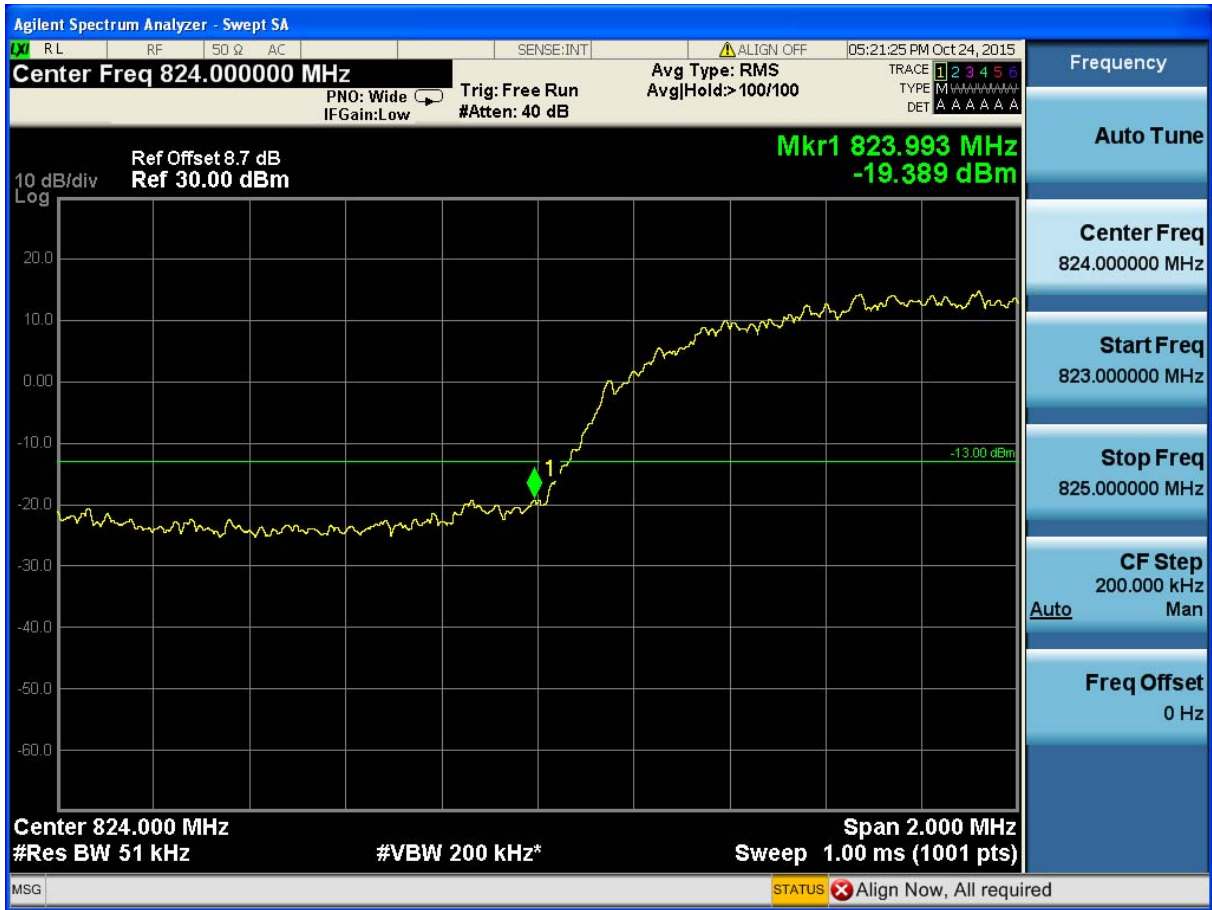

(Plot 4.5.3 A: Channel 4132: 826.4MHz @ WCDMA Band V)



(Plot 4.5.3 B: Channel 4233: 846.6MHz @ WCDMA Band V)

## 4.5 Spurious Emission on Antenna Port

### TEST APPLICABLE

The following steps outline the procedure used to measure the conducted emissions from the EUT.

1. Determine frequency range for measurements: From CFR 2.1057 the spectrum should be investigated from the lowest radio frequency generated in the equipment up to at least the 10th harmonic of the carrier frequency. For the equipment of WCDMA band II/IV, this equates to a frequency range of 9 KHz to 20GHz, data taken from 9 KHz to 20 GHz. For WCDMA Band V, data taken from 9 KHz to 13.6 GHz.
2. The sweep time is set automatically by instrument itself. That should be the optimal sweep time for the span and the RBW. If the sweep time is too short, that is sweep is too fast, the sweep result is not accurate; if the sweep time is too long, that is sweep is too low, some frequency components may be lost. The instrument will give an optimal sweep time according the selected span and RBW.
3. The procedure to get the conducted spurious emission is as follows:  
The trace mode is set to MaxHold to get the highest signal at each frequency;  
Wait 25 seconds;  
Get the result.
4. Determine EUT transmit frequencies: below outlines the band edge frequencies pertinent to conducted emissions testing.

### TEST CONFIGURATION

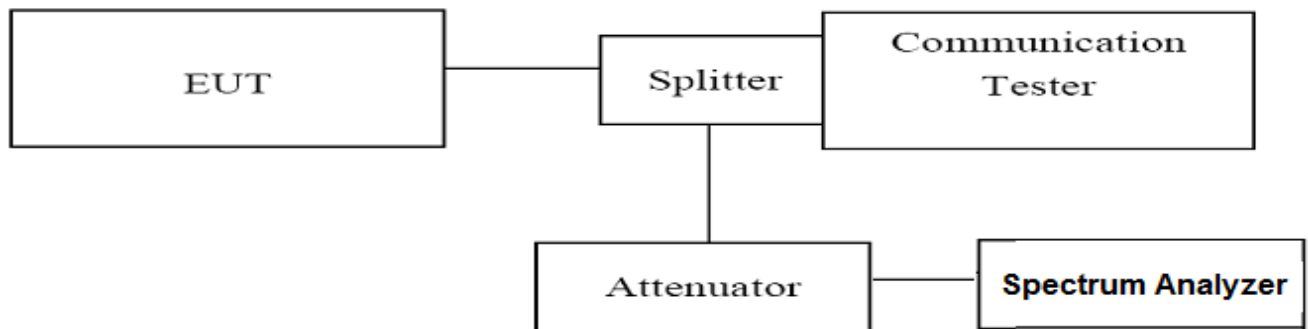

### TEST PROCEDURE

1. The EUT was set up for the max output power with pseudo random data modulation;
2. The power was measured with Agilent Spectrum Analyzer N9030A (peak);
3. These measurements were done at 3 frequencies for WCDMA band II/IV/V. (low, middle and high of operational frequency range).

### TEST LIMIT

Part 24.238, Part 22.917 and Part 22.54 specify that the power of any emission outside of the authorized operating frequency ranges must be attenuated below the transmitting power (P) by a factor of at least  $43 + 10 \log(P)$  dB.

The specification that emissions shall be attenuated below the transmitter power (P) by at least  $43 + 10 \log(P)$  dB, translates in the relevant power range (1 to 0.001 W) to -13 dBm. At 1 W the specified minimum attenuation becomes 43 dB and relative to a 30 dBm (1 W) carrier becomes a limit of -13 dBm. At 0.001 W (0 dBm) the minimum attenuation is 13 dB, which again yields a limit of -13 dBm. In this way a translation of the specification from relative to absolute terms is carried out.

### TEST RESULTS

### 4.5.1 For UMTS/TM1/WCDMA Band II Test Results

#### A. Test Verdict

Test Mode/ Channel	Frequency (MHz)	Frequency Range	Refer to Plot	Limit (dBm)	Verdict
UMTS/TM1/WCDMA Band II/9262	1852.40	9KHz-150KHz	Plot 4.5.1 A1	-13.00	PASS
		150KHz-30MHz	Plot 4.5.1 A2	-13.00	PASS
		30MHz-1GHz	Plot 4.5.1 A3	-13.00	PASS
		1GHz-7GHz	Plot 4.5.1 A4	-13.00	PASS
		7GHz-13.6GHz	Plot 4.5.1 A5	-13.00	PASS
		13.6GHz-25GHz	Plot 4.5.1 A6	-13.00	PASS
UMTS/TM1/WCDMA Band II/9400	1880.00	9KHz-150KHz	Plot 4.5.1 B1	-13.00	PASS
		150KHz-30MHz	Plot 4.5.1 B2	-13.00	PASS
		30MHz-1GHz	Plot 4.5.1 B3	-13.00	PASS
		1GHz-7GHz	Plot 4.5.1 B4	-13.00	PASS
		7GHz-13.6GHz	Plot 4.5.1 B5	-13.00	PASS
		13.6GHz-25GHz	Plot 4.5.1 B6	-13.00	PASS
UMTS/TM1/WCDMA Band II/9538	1907.60	9KHz-150KHz	Plot 4.5.1 C1	-13.00	PASS
		150KHz-30MHz	Plot 4.5.1 C2	-13.00	PASS
		30MHz-1GHz	Plot 4.5.1 C3	-13.00	PASS
		1GHz-7GHz	Plot 4.5.1 C4	-13.00	PASS
		7GHz-13.6GHz	Plot 4.5.1 C5	-13.00	PASS
		13.6GHz-25GHz	Plot 4.5.1 C6	-13.00	PASS

Note:

1. In general, the worse case attenuation requirement shown above was applied.
2. \*\*\* means that the emission level is too low to be measured or at least 20 dB down than the limit.

#### B. Test Plots

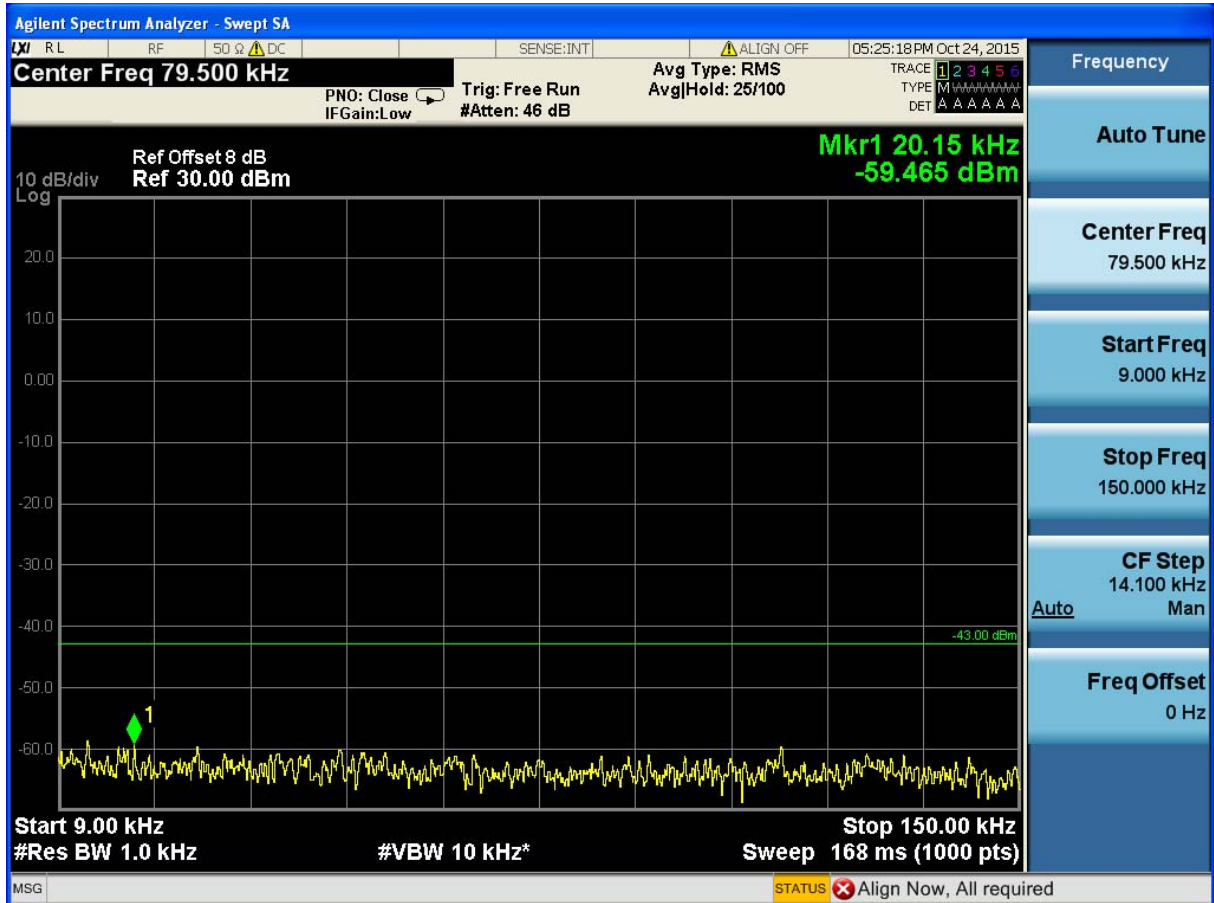

(Plot 4.5.1 A1: Channel 9262: 1852.4MHz @ Traffic WCDMA Band II)

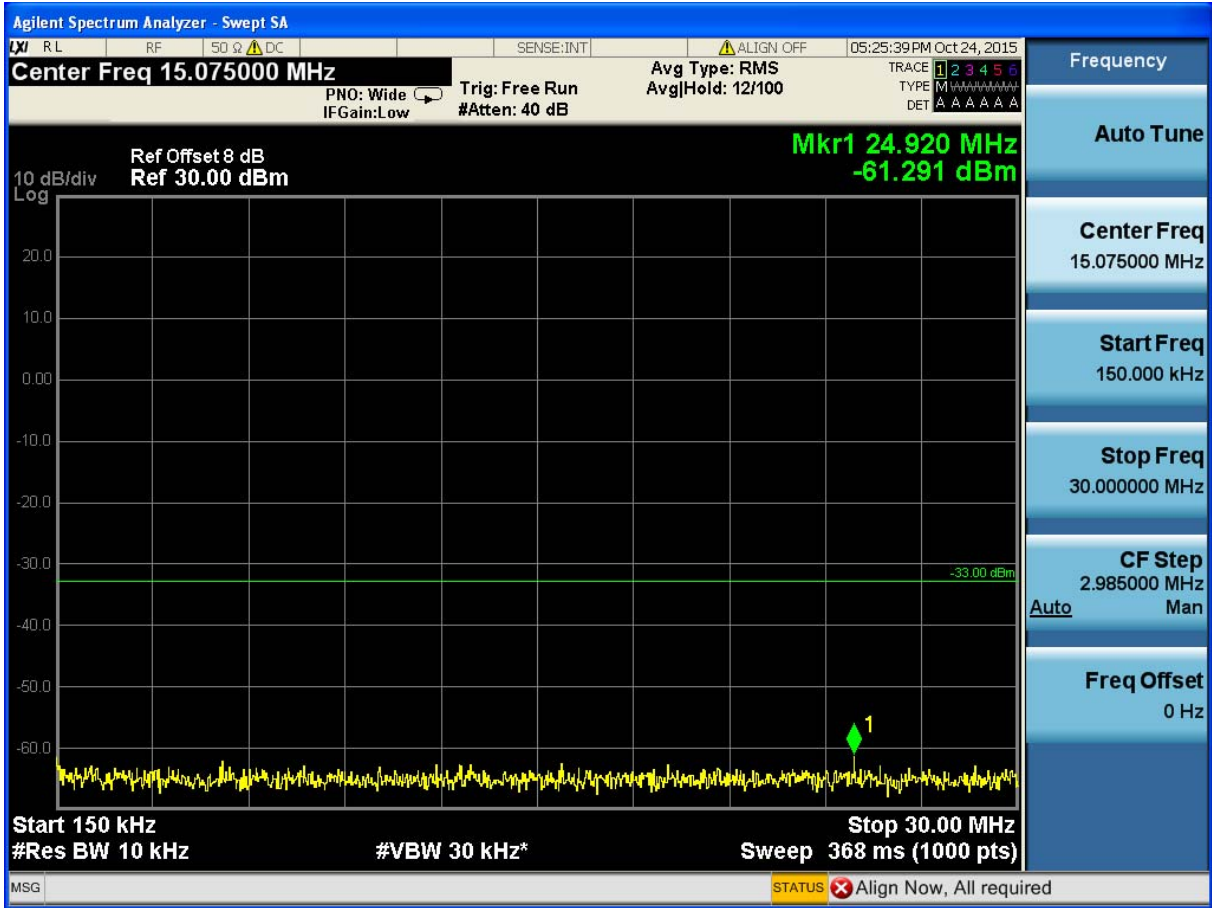

(Plot 4.5.1 A2: Channel 9262: 1852.4MHz @ Traffic WCDMA Band II)

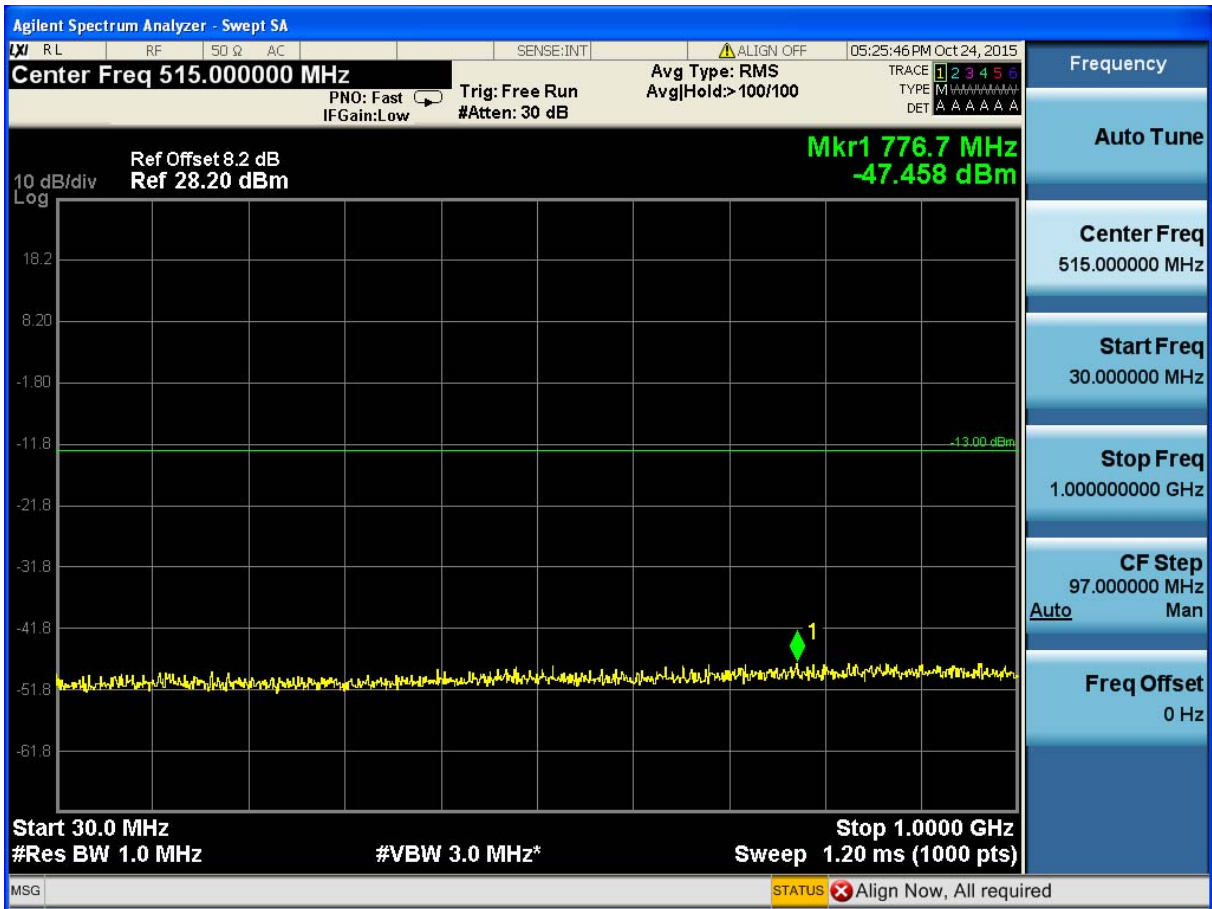

(Plot 4.5.1 A3: Channel 9262: 1852.4MHz @ Traffic WCDMA Band II)

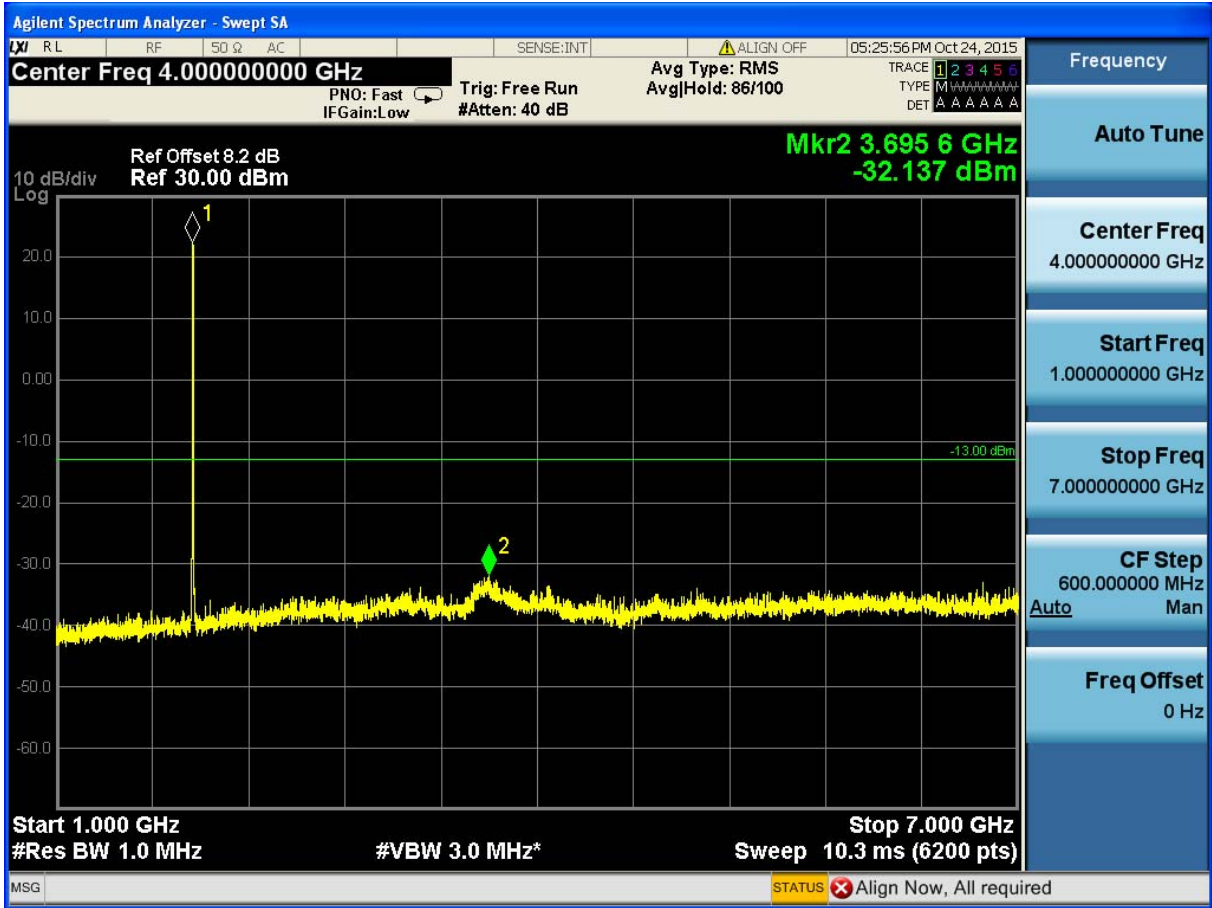

(Plot 4.5.1 A4: Channel 9262: 1852.4MHz @ Traffic WCDMA Band II)

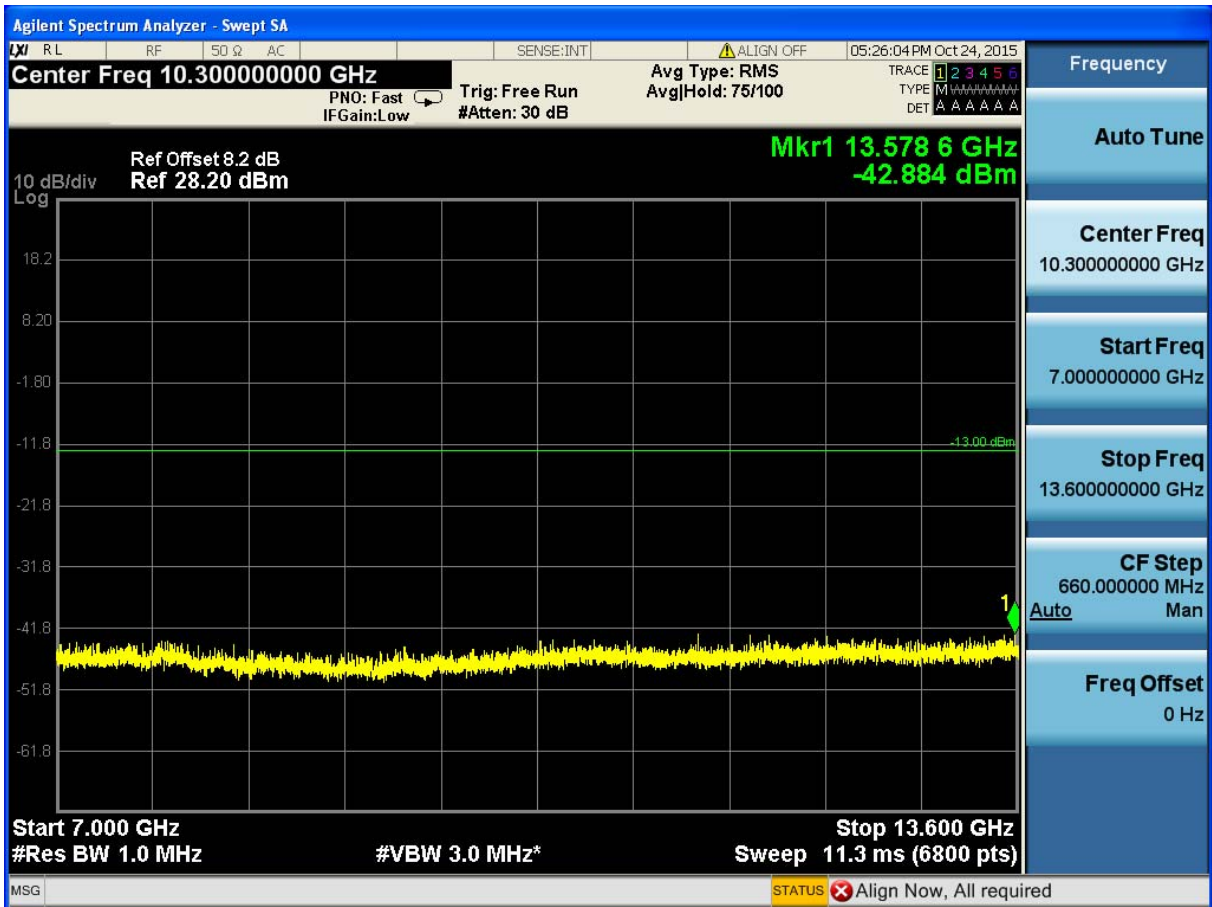

(Plot 4.5.1 A5: Channel 9262: 1852.4MHz @ Traffic WCDMA Band II)