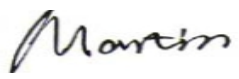
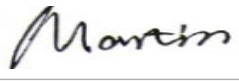
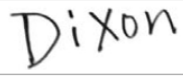

FCC TEST REPORT

47 CFR FCC Part 15 Subpart B

| | | |
|---|---|---|
| Report Reference No.....: | MWR1409002906 | |
| FCC ID.....: | RQQHLT-E415 | |
| Compiled by (position+printed name+signature)... | File administrators Martin Ao |  |
| Supervised by (position+printed name+signature)... | Test Engineer Martin Ao |  |
| Approved by (position+printed name+signature)... | Manager Dixon Hao |  |
| Date of issue.....: | Sep 20, 2014 | |
| Representative Laboratory Name ..: | Maxwell International Co., Ltd. | |
| Address | Room 509, Hongfa center building, Baoan District, Shenzhen, Guangdong, China | |
| Testing Laboratory Name | Shenzhen CTL Testing Technology Co., Ltd. | |
| Address | Floor 1-A, Baisha Technology Park, No. 3011, Shahexi Road, Nanshan, Shenzhen, China | |
| Applicant's name.....: | HYUNDAI CORPORATION | |
| Address | 140-2, Kye-dong, Chongro-ku, Seoul, South Korea | |
| Test specification | | |
| Standard | 47 CFR FCC Part 15 Subpart B - Unintentional Radiators | |
| | ANSI C63.4: 2009 | |
| TRF Originator.....: | Maxwell International Co., Ltd. | |
| Master TRF.....: | Dated 2011-05 | |
| Maxwell International Co., Ltd. All rights reserved. | | |
| This publication may be reproduced in whole or in part for non-commercial purposes as long as the Maxwell International Co., Ltd. as copyright owner and source of the material. Maxwell International Co., Ltd. takes no responsibility for and will not assume liability for damages resulting from the reader's interpretation of the reproduced material due to its placement and context. | | |
| Test item description | Mobile Phone | |
| Trade Mark | HYUNDAI | |
| Manufacturer.....: | WASAM TECHNOLOGY (SHEN ZHEN) CO.,LTD. | |
| Model/Type reference.....: | E415 | |
| Listed Models | / | |
| Rating | DC 3.70V | |
| Hardware version | HYUNDAI_W407_V1.0 | |
| Software version | HYUNDAI_W407_V1.0 | |
| Result.....: | PASS | |

TEST REPORT

| | | |
|--------------------------|----------------------|---------------|
| Test Report No. : | MWR1409002906 | Sep 20, 2014 |
| | | Date of issue |

Equipment under Test : Mobile Phone

Model /Type : E415

Listed Models : /

Applicant : **HYUNDAI CORPORATION**

Address : 140-2, Kye-dong, Chongro-ku, Seoul, South Korea

Manufacturer : **WASAM TECHNOLOGY (SHEN ZHEN) CO.,LTD.**

Address : B,F Building, (Hengqiang Industrial Park), Bogang Taifeng Industrial Zone, Shajing Town, Bao'an District, Shenzhen, China.

| | |
|---------------------|-------------|
| Test Result: | PASS |
|---------------------|-------------|

The test report merely corresponds to the test sample.

It is not permitted to copy extracts of these test result without the written permission of the test laboratory.

Contents

| | | |
|-----------|---|-----------|
| 1. | <u>TEST STANDARDS.....</u> | 4 |
| 2. | <u>SUMMARY</u> | 5 |
| 2.1. | General Remarks | 5 |
| 2.2. | Product Description | 5 |
| 2.3. | Equipment under Test | 5 |
| 2.4. | Short description of the Equipment under Test (EUT) | 5 |
| 2.5. | EUT operation mode | 6 |
| 2.6. | Related Submittal(s) / Grant (s) | 6 |
| 2.7. | Internal Identification of AE used during the test | 6 |
| 2.8. | Modifications | 6 |
| 2.9. | EUT configuration | 6 |
| 2.10. | Configuration of Tested System | 7 |
| 2.11. | NOTE | 7 |
| 3. | <u>TEST ENVIRONMENT.....</u> | 8 |
| 3.1. | Address of the test laboratory | 8 |
| 3.2. | Test Facility | 8 |
| 3.3. | Environmental conditions | 8 |
| 3.4. | Statement of the measurement uncertainty | 8 |
| 3.5. | Equipments Used during the Test | 9 |
| 4. | <u>TEST CONDITIONS AND RESULTS.....</u> | 10 |
| 4.1. | Conducted Emissions Test | 10 |
| 4.2. | Radiated Emission Test | 12 |
| 5. | <u>TEST SETUP PHOTOS OF THE EUT</u> | 15 |

1. TEST STANDARDS

The tests were performed according to following standards:

[47 CFR FCC Part 15 Subpart B](#) - Unintentional Radiators

[ANSI C63.4: 2009](#) – American National Standard for Methods of Measurement of Radio-Noise Emissions from Low-Voltage Electrical and Electronic Equipment in the Range of 9 kHz to 40GHz

2. SUMMARY

2.1. General Remarks

| | | |
|--------------------------------|---|--------------|
| Date of receipt of test sample | : | Sep 10, 2014 |
| | | |
| Testing commenced on | : | Sep 10, 2014 |
| | | |
| Testing concluded on | : | Sep 20, 2014 |

2.2. Product Description

The **HYUNDAI CORPORATION's** Model: E415 or the "EUT" as referred to in this report; more general information as follows, for more details, refer to the user's manual of the EUT.

| | |
|------------------------------|---------------------------------------|
| Name of EUT | Mobile Phone |
| Model Number | E415 |
| FCC ID | RQQHLT-E415 |
| Modulation Type | GMSK for GSM/GPRS; QPSK for WCDMA |
| Antenna Type | Internal |
| GSM/EDGE/GPRS | Supported GPRS |
| Extreme temp. Tolerance | -30°C to +50°C |
| Extreme vol. Limits | 3.40VDC to 4.20VDC (nominal: 3.70VDC) |
| GSM Operation Frequency Band | GSM 850MHz/ PCS 1900MHz |
| GSM Release Version | R99 |
| GPRS operation mode | Class B |
| GPRS Multislot Class | 12 |
| EGPRS Multislot Class | Only support downlink mode |

2.3. Equipment under Test

Power supply system utilised

| | | | |
|----------------------|---|---|-----------------------------------|
| Power supply voltage | : | <input type="radio"/> 120V / 60 Hz | <input type="radio"/> 115V / 60Hz |
| | | <input type="radio"/> 12 V DC | <input type="radio"/> 24 V DC |
| | | <input checked="" type="radio"/> Other (specified in blank below) | |

DC 3.70V

2.4. Short description of the Equipment under Test (EUT)

2.4.1 General Description

E415 is subscriber equipment in the WCDMA/GSM system. The HSPA/UMTS frequency band is Band II, Band IV; The GSM/GPRS/EDGE (EDGE downlink only) frequency and includes GSM850 and GSM900 and DCS1800 and PCS1900, but only Band II and Band V and GSM850 and PCS1900 bands test data included in this report. The Mobile Phone implements such functions as RF signal receiving/transmitting, HSPA/UMTS and GSM/GPRS/EDGE protocol processing, voice, video MMS service, GPS, AGPS and WIFI etc. Externally it provides micro SD card interface, earphone port (to provide voice service) and SIM card interface. It also provides Bluetooth module to synchronize data between a PC and the phone, or to use the built-in modem of the phone to access the Internet with a PC, or to exchange data with other Bluetooth devices.

2.4.2 EUT Identity

| | |
|----------|-----------------|
| IMEI No. | |
| SIM 1 | 135790246811220 |
| SIM 2 | 135790246811228 |

NOTE: Unless otherwise noted in the report, the functional boards installed in the units shall be selected from the below list, but not means all the functional boards listed below shall be installed in one unit.

2.4.3 Test Environments

NOTE: The values used in the test report maybe stringent than the declared.

| Environment Parameter | Selected Values During Tests | | |
|-----------------------|------------------------------|---------|-------------------|
| NTNV | Temperature | Voltage | Relative Humidity |
| | Ambient | 3.7VDC | Ambient |

2.5. EUT operation mode

The EUT has been tested under typical operating condition.

2.6. Related Submittal(s) / Grant (s)

This submittal(s) (test report) is intended for **FCC ID: RQQLT-E415** filing to comply with the FCC Part 15, Subpart B Rules.

2.7. Internal Identification of AE used during the test

| AE ID* | Description |
|--------|-------------|
| AE1 | Battery |
| AE2 | Charger |

AE1

Model: E415
 Capacitance: 1400mAh
 Nominal Voltage: 3.70V

AE2:

Model: E415

*AE ID: is used to identify the test sample in the lab internally.
 We not used AE2 when for FCC Part 15B test.

2.8. Modifications

No modifications were implemented to meet testing criteria.

2.9. EUT configuration

The following peripheral devices and interface cables were connected during the measurement:

- supplied by the manufacturer
- supplied by the lab

| | | | |
|-----------------------|-------------|----------------|---|
| <input type="radio"/> | Power Cable | Length (m) : | / |
| | | Shield : | / |
| | | Detachable : | / |
| <input type="radio"/> | Multimeter | Manufacturer : | / |
| | | Model No. : | / |

2.10. Configuration of Tested System

Configuration of Tested System

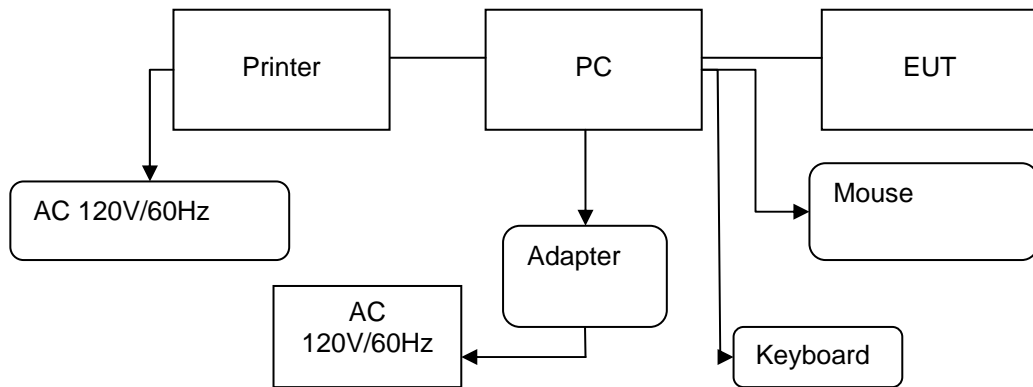

Equipment Used in Tested System

| No. | Equipment | Manufacturer | Model No. | Serial No. | Length | shielded/unshielded | Notes |
|-----|---------------------------------|--------------|----------------|-------------------------|--------|---------------------|-------|
| 1 | PC | Acer | E1-571G | 1RNN42X | / | / | DOC |
| 2 | Printer | HP | C3990 | C3990A | / | / | DOC |
| 3 | Mouse | DELL | MO56UO A | G0E02SY7 | 1.00m | unshielded | DOC |
| 4 | Keyboard | DELL | L100 | CNRH656658907 26009L | / | / | DOC |
| 5 | USB Cable (EUT to PC) | Genshuo | USB 2.0 | N/A | 0.60m | unshielded | N/A |
| 6 | USB Cable (Printer to PC) | Genshuo | USB 2.0 | N/A | 1.20m | unshielded | N/A |
| 7 | Power line | / | / | N/A | 1.00m | unshielded | N/A |
| 8 | Adapter | HIPRO | HP- A0904A3 | F1120709016S40 4 | 1.50m | unshielded | DOC |

2.11. NOTE

- The EUT is a Mobile Phone with WCDMA/GSM/GPRS,WiFi and Bluetooth fuction,The functions of the EUT listed as below:

| | Test Standards | Reference Report |
|-----------|-------------------------|------------------|
| GSM/GPRS | FCC Part 22/FCC Part 24 | MWR1409002901 |
| WCDMA | FCC Part 22/FCC Part 24 | MWR1409002902 |
| Bluetooth | FCC Part 15 C 15.247 | MWR1409002903 |
| BLE | FCC Part 15 C 15.247 | MWR1409002904 |
| WiFi | FCC Part 15 C 15.247 | MWR1409002905 |
| USB Port | FCC Part 15 B | MWR1409002906 |
| SAR | FCC Part 2 §2.1093 | MWR1409002907 |

3. TEST ENVIRONMENT

3.1. Address of the test laboratory

Shenzhen CTL Testing Technology Co., Ltd.

Floor 1-A, Baisha Technology Park, No. 3011, Shahexi Road, Nanshan, Shenzhen, China

The sites are constructed in conformance with the requirements of ANSI C63.7, ANSI C63.4 (2003) and CISPR Publication 22.

3.2. Test Facility

The test facility is recognized, certified, or accredited by the following organizations:

FCC-Registration No.: 970318

Shenzhen CTL Testing Technology Co., Ltd. has been registered and fully described in a report filed with the (FCC) Federal Communications Commission. The acceptance letter from the FCC is maintained in our files. Registration 970318, Dec 19, 2013

3.3. Environmental conditions

During the measurement the environmental conditions were within the listed ranges:

Temperature: 15-35 ° C

Humidity: 30-60 %

Atmospheric pressure: 950-1050mbar

3.4. Statement of the measurement uncertainty

The data and results referenced in this document are true and accurate. The reader is cautioned that there may be errors within the calibration limits of the equipment and facilities. The measurement uncertainty was calculated for all measurements listed in this test report acc. to CISPR 16 - 4 „Specification for radio disturbance and immunity measuring apparatus and methods – Part 4: Uncertainty in EMC Measurements“ and is documented in the Shenzhen CTL Testing Technology Co., Ltd. quality system acc. to DIN EN ISO/IEC 17025. Furthermore, component and process variability of devices similar to that tested may result in additional deviation. The manufacturer has the sole responsibility of continued compliance of the device.

Hereafter the best measurement capability for Shenzhen CTL Testing Technology Co., Ltd. is reported:

| Test | Range | Measurement Uncertainty | Notes |
|-----------------------|------------|-------------------------|-------|
| Radiated Emission | 30~1000MHz | 4.24 dB | (1) |
| Radiated Emission | 1~18GHz | 5.16 dB | (1) |
| Radiated Emission | 18-40GHz | 5.54 dB | (1) |
| Conducted Disturbance | 0.15~30MHz | 3.39 dB | (1) |

(1) This uncertainty represents an expanded uncertainty expressed at approximately the 95% confidence level using a coverage factor of k=2.

3.5. Equipments Used during the Test

| AC Power Conducted Emission | | | | | |
|-----------------------------|-------------------|---------------|-------------|------------|------------|
| Item | Test Equipment | Manufacturer | Model No. | Serial No. | Last Cal. |
| 1 | Artificial Mains | Rohde&Schwarz | ENV216 | 101316 | 2014/07/02 |
| 2 | EMI Test Receiver | Rohde&Schwarz | ESCI3 | 103710 | 2014/07/02 |
| 3 | Pulse Limiter | Com-Power | LIT-153 | 53226 | 2014/07/01 |
| 4 | EMI Test Software | Rohde&Schwarz | ES-K1 V1.71 | N/A | N/A |

| Radiated Emission | | | | | |
|-------------------|--------------------|------------------------------|-----------|------------|------------|
| Item | Test Equipment | Manufacturer | Model No. | Serial No. | Last Cal. |
| 1 | Bilog Antenna | Sunol Sciences Corp. | JB1 | A061713 | 2014/07/12 |
| 2 | EMI TEST Receivcer | Rohde&Schwarz | ESCI3 | 103710 | 2014/07/02 |
| 3 | EMI TEST Software | Audix | E3 | N/A | N/A |
| 4 | EMI TEST Software | Rohde&Schwarz | ESK1 | N/A | N/A |
| 5 | HORN ANTENNA | Sunol Sciences Corp. | DRH-118 | A062013 | 2014/07/12 |
| 6 | Amplifer | HP | 8447D | 3113A07663 | 2013/10/27 |
| 7 | Preamplifier | HP | 8349B | 3155A00882 | 2014/07/03 |
| 8 | Amplifer | Compliance Direction systems | PAP1-4060 | 129 | 2014/07/03 |
| 9 | Loop Antenna | Rohde&Schwarz | HFH2-Z2 | 100020 | 2014/06/29 |
| 10 | TURNTABLE | MATURO | TT2.0 | ---- | N/A |
| 11 | ANTENNA MAST | MATURO | TAM-4.0-P | ---- | N/A |
| 12 | Horn Antenna | SCHWARZBECK | BBHA9170 | 25849 | 2014/06/21 |
| 13 | Spectrum Analyzer | Rohde&Schwarz | FSU26 | 201148 | 2014/07/02 |

The Cal.Interval was one year

4. TEST CONDITIONS AND RESULTS

4.1. Conducted Emissions Test

TEST CONFIGURATION

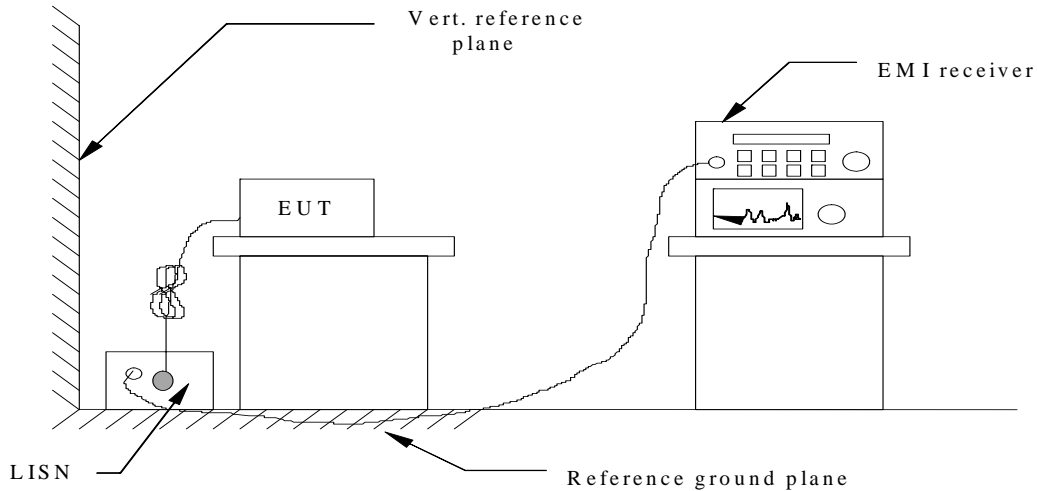

TEST PROCEDURE

1. The equipment was set up as per the test configuration to simulate typical actual usage per the user's manual. The EUT is a tabletop system; a wooden table with a height of 0.8 meters is used and is placed on the ground plane as per ANSI C63.4-2009.
2. Support equipment, if needed, was placed as per ANSI C63.4-2009.
3. All I/O cables were positioned to simulate typical actual usage as per ANSI C63.4-2009.
4. The EUT received AC120V/60Hz power through a Line Impedance Stabilization Network (LISN) which supplied power source and was grounded to the ground plane.
5. All support equipments received AC power from a second LISN, if any.
6. The EUT test program was started. Emissions were measured on each current carrying line of the EUT using a spectrum Analyzer / Receiver connected to the LISN powering the EUT. The LISN has two monitoring points: Line 1 (Hot Side) and Line 2 (Neutral Side). Two scans were taken: one with Line 1 connected to Analyzer / Receiver and Line 2 connected to a 50 ohm load; the second scan had Line 1 connected to a 50 ohm load and Line 2 connected to the Analyzer / Receiver.
7. Analyzer / Receiver scanned from 150 KHz to 30MHz for emissions in each of the test modes.
8. During the above scans, the emissions were maximized by cable manipulation.

CONDUCTED POWER LINE EMISSION LIMIT

For unintentional device, according to § 15.107(a) Line Conducted Emission Limits is as following :

| Frequency (MHz) | Maximum RF Line Voltage (dBµV) | | | |
|-----------------|--------------------------------|------|---------|--------|
| | CLASS A | | CLASS B | |
| | Q.P. | Ave. | Q.P. | Ave. |
| 0.15 - 0.50 | 79 | 66 | 66-56* | 56-46* |
| 0.50 - 5.00 | 73 | 60 | 56 | 46 |
| 5.00 - 30.0 | 73 | 60 | 60 | 50 |

* Decreasing linearly with the logarithm of the frequency

TEST RESULTS

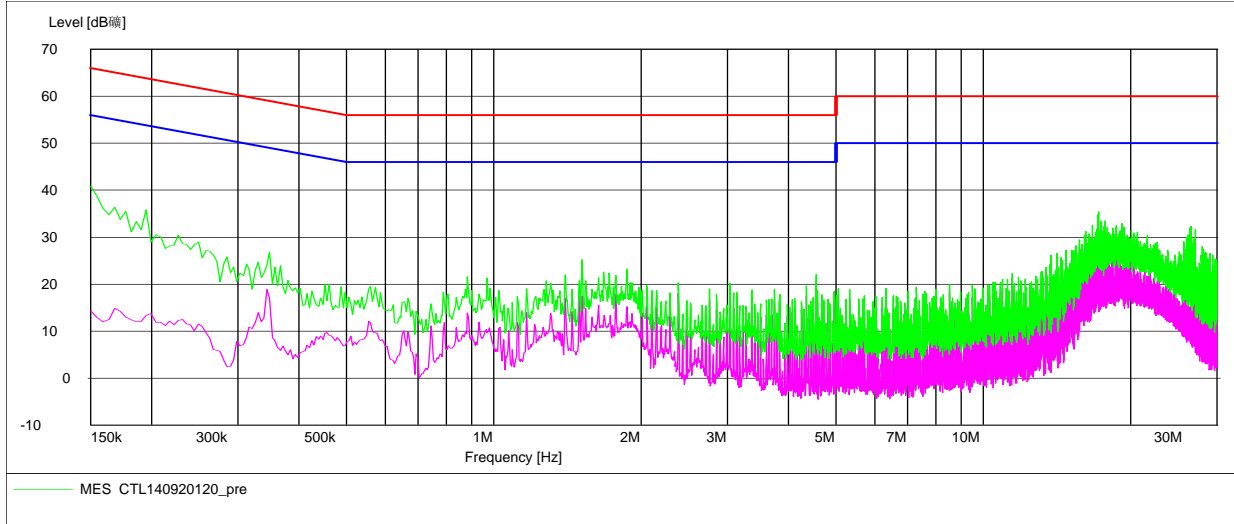

| Frequency MHz | Level dBμV | Transd dB | Limit dBμV | Margin dB | Detector | Line |
|---------------|------------|-----------|------------|-----------|----------|------|
| 16.712000 | 30.60 | 10.8 | 60 | 29.4 | QP | N |
| 17.414000 | 31.90 | 10.8 | 60 | 28.1 | QP | N |
| 17.690000 | 30.20 | 10.8 | 60 | 29.8 | QP | N |
| 17.414000 | 30.30 | 10.8 | 50 | 19.7 | AV | N |
| 17.696000 | 28.80 | 10.8 | 50 | 21.2 | AV | N |
| 18.674000 | 27.90 | 10.9 | 50 | 22.1 | AV | N |

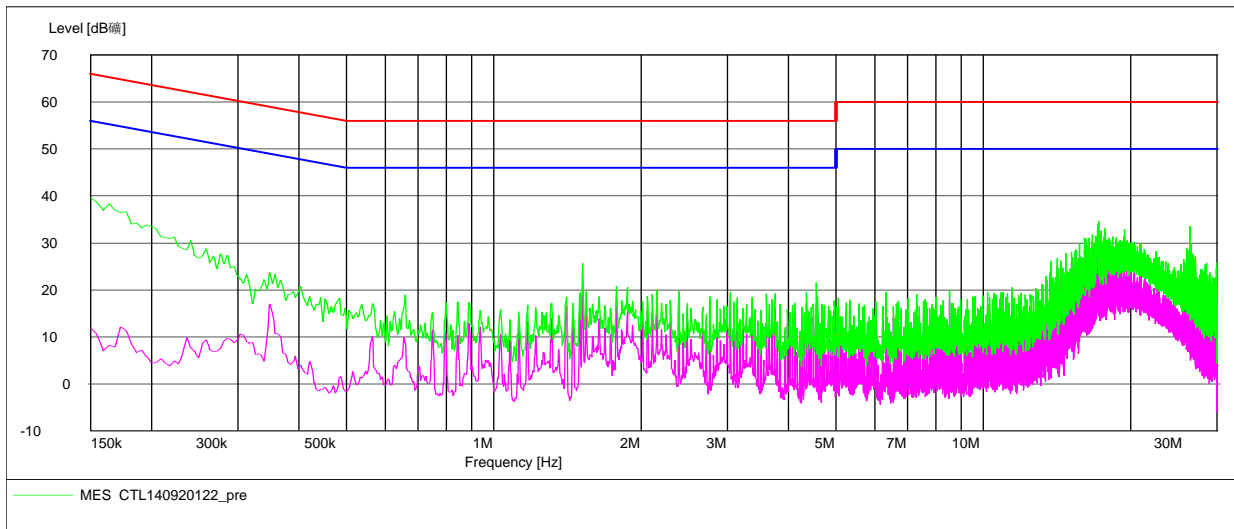

| Frequency MHz | Level dBμV | Transd dB | Limit dBμV | Margin dB | Detector | Line |
|---------------|------------|-----------|------------|-----------|----------|------|
| 17.414000 | 31.20 | 10.8 | 60 | 28.8 | QP | L1 |
| 17.696000 | 29.90 | 10.8 | 60 | 30.1 | QP | L1 |
| 19.376000 | 29.40 | 10.9 | 60 | 30.6 | QP | L1 |
| 16.712000 | 29.30 | 10.8 | 50 | 20.7 | AV | L1 |
| 17.084000 | 29.20 | 10.8 | 50 | 20.8 | AV | L1 |
| 17.414000 | 29.50 | 10.8 | 50 | 20.5 | AV | L1 |

4.2. Radiated Emission Test

TEST CONFIGURATION

Frequency range: 9 KHz – 30MHz

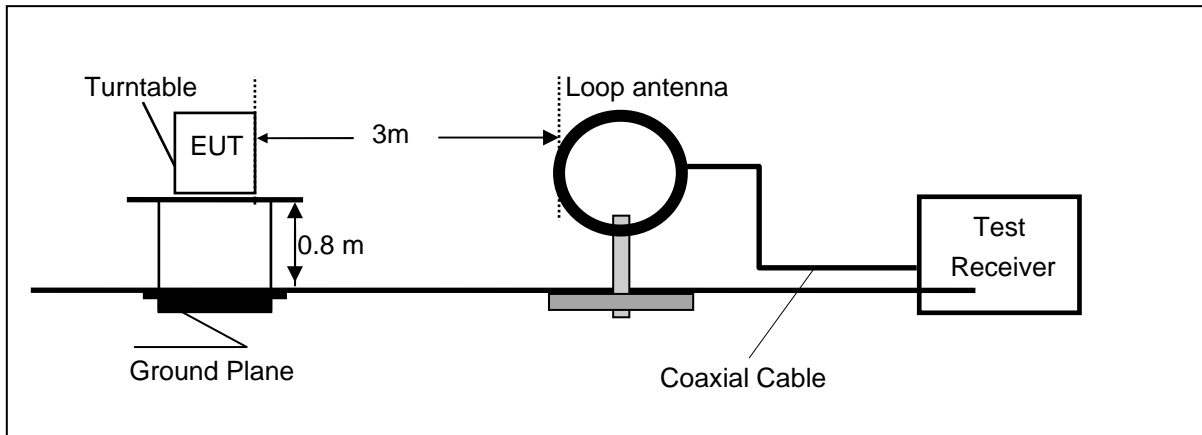

Frequency range: 30MHz – 1000MHz

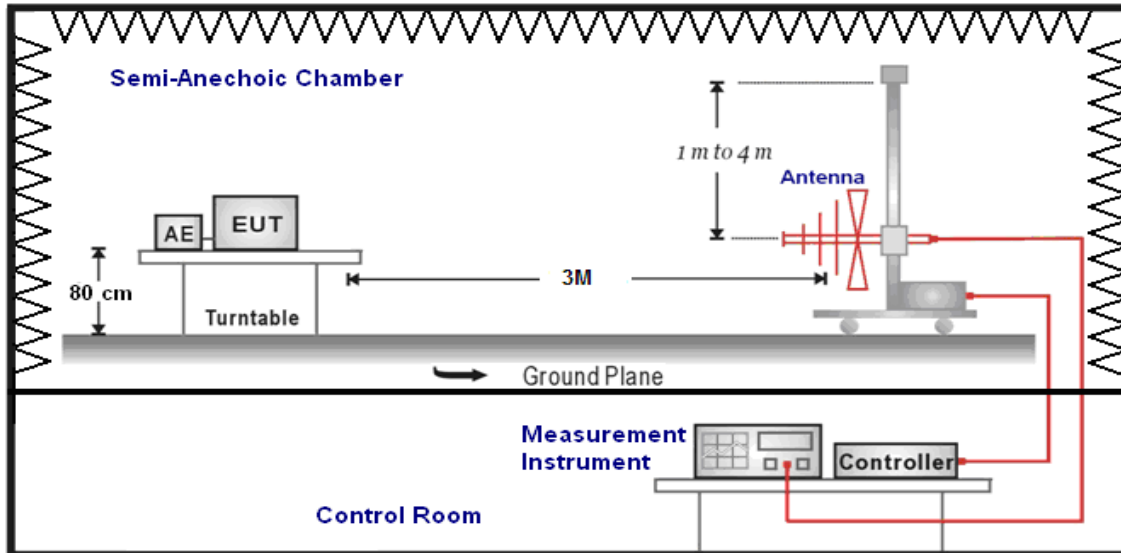

Frequency range above 1GHz-25GHz

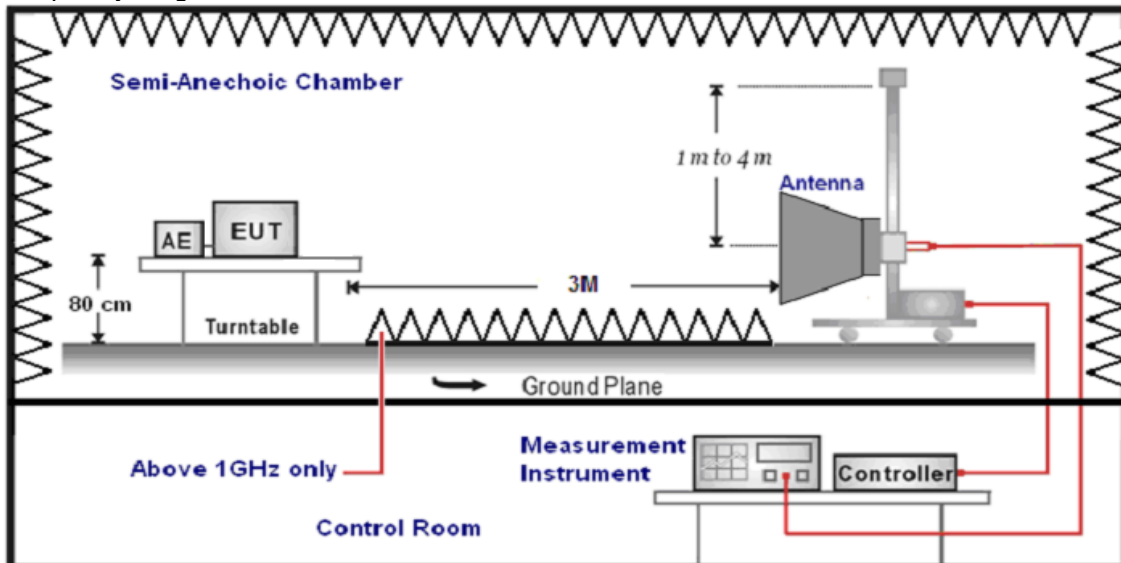

TEST PROCEDURE

1. The EUT is placed on a turntable, which is 0.8m above ground plane.
2. The turntable shall be rotated for 360 degrees to determine the position of maximum emission level.
3. EUT is set 3m away from the receiving antenna, which is varied from 1m to 4m to find out the highest emissions.
4. Maximum procedure was performed on the six highest emissions to ensure EUT compliance.
5. And also, each emission was to be maximized by changing the polarization of receiving antenna both horizontal and vertical.
6. Repeat above procedures until the measurements for all frequencies are complete.
7. The maximum operation frequency was 512MHz, the radiated emission test frequency from 9 KHz to 18GHz.

FIELD STRENGTH CALCULATION

The field strength is calculated by adding the Antenna Factor and Cable Factor and subtracting the Amplifier Gain and Duty Cycle Correction Factor (if any) from the measured reading. The basic equation with a sample calculation is as follows:

$$FS = RA + AF + CL - AG$$

| | |
|---------------------------|--|
| Where FS = Field Strength | CL = Cable Attenuation Factor (Cable Loss) |
| RA = Reading Amplitude | AG = Amplifier Gain |
| AF = Antenna Factor | |

For example

| Frequency (MHz) | FS (dBµV/m) | RA (dBµV/m) | AF (dB) | CL (dB) | AG (dB) | Transd (dB) |
|-----------------|-------------|-------------|---------|---------|---------|-------------|
| 300.00 | 40 | 58.1 | 12.2 | 1.6 | 31.90 | -18.1 |

$$Transd = AF + CL - AG$$

RADIATION LIMIT

For unintentional device, according to § 15.109(a), except for Class A digital devices, the field strength of radiated emissions from unintentional radiators at a distance of 3 meters shall not exceed the following values:

| Frequency (MHz) | Distance (Meters) | Radiated (dBµV/m) | Radiated (µV/m) |
|-----------------|-------------------|------------------------|-----------------|
| 0.009-0.49 | 300 | 20log(2400/F(KHz))+80 | 2400/F(KHz) |
| 0.49-1.705 | 30 | 20log(24000/F(KHz))+40 | 24000/F(KHz) |
| 1.705-30 | 30 | 20log(30)+40 | 30 |
| 30-88 | 3 | 40.0 | 100 |
| 88-216 | 3 | 43.5 | 150 |
| 216-960 | 3 | 46.0 | 200 |
| Above 960 | 3 | 54.0 | 500 |

TEST RESULTS

Remark: 1. We not recorded emission level for 10GHz to 18GHz as emissio level was at least 10dB below emission level.

For 9KHz to 30MHz

| Frequency (MHz) | Corrected Reading (dBµV/m)@3m | FCC Limit (dBµV/m) @3m | Margin (dB) | Detector | Result |
|-----------------|-------------------------------|------------------------|-------------|----------|--------|
| 12.00 | 45.32 | 69.54 | 24.22 | QP | PASS |
| 24.00 | 43.71 | 69.54 | 25.83 | QP | PASS |

For 30MHz-1GHz

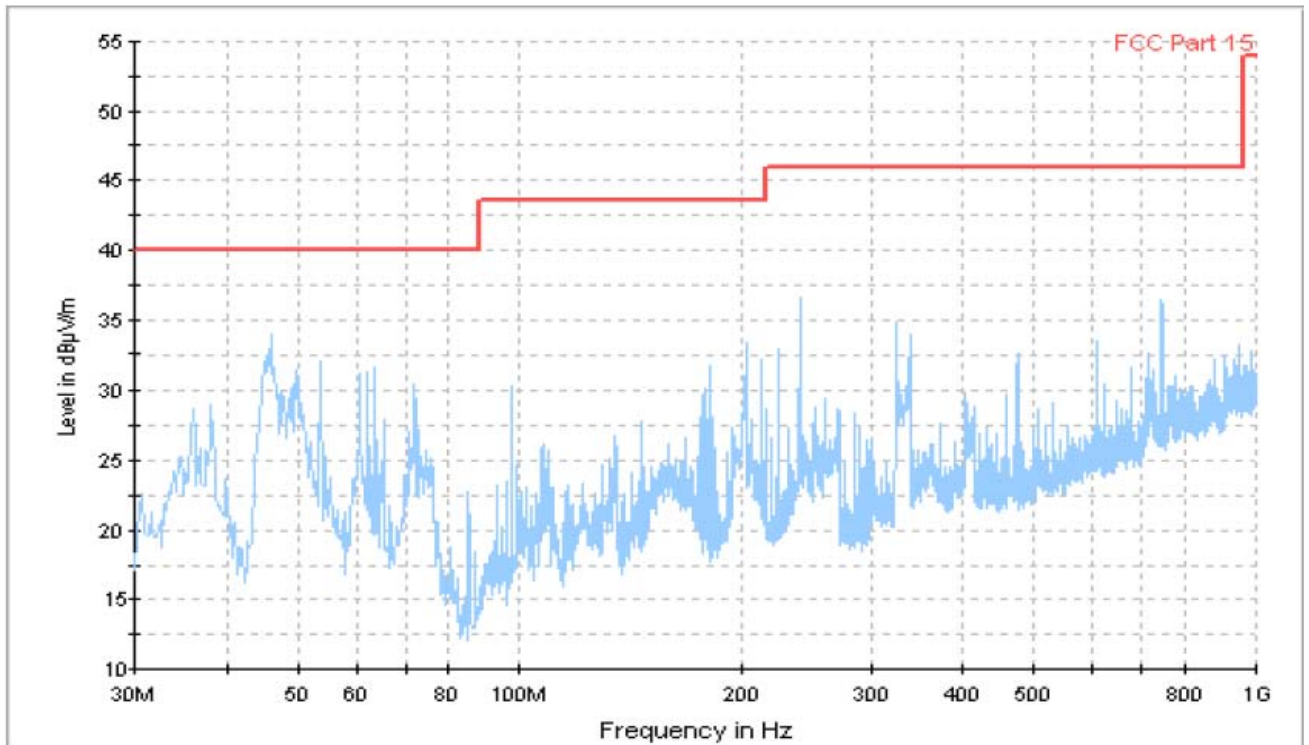

| Frequency (MHz) | Reading (dBuV) | Correct Factor (dB/m) | Result (dBuV/m) | Limit (dBuV/m) | Margin (dB) | Detector | Ant. Polar. H / V |
|-----------------|----------------|-----------------------|-----------------|----------------|-------------|----------|-------------------|
| 46.78 | 18.96 | -11.30 | 30.26 | 40.00 | 9.74 | QP | V |
| 240.00 | 25.81 | -8.60 | 34.41 | 46.00 | 11.59 | QP | H |

For 1GHz-10GHz

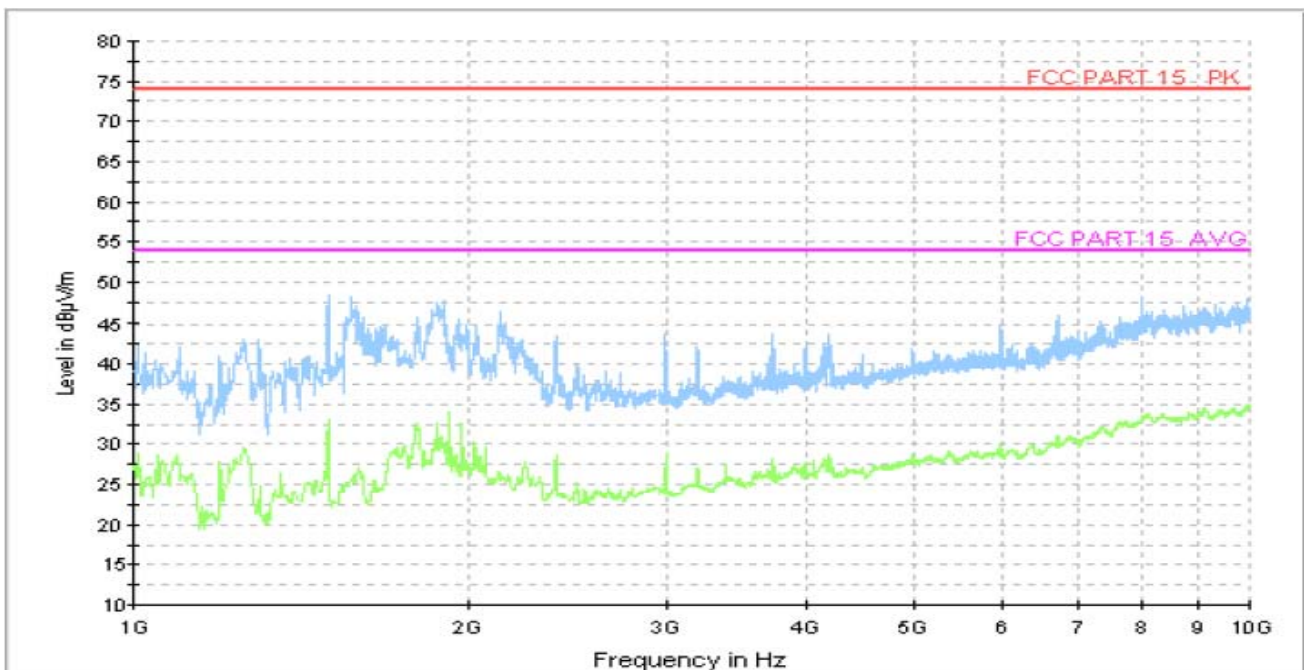

| Frequency (MHz) | Reading (dBuV) | Correct Factor (dB/m) | Result (dBuV/m) | Limit (dBuV/m) | Margin (dB) | Detector | Ant. Polar. H / V |
|-----------------|----------------|-----------------------|-----------------|----------------|-------------|-----------|-------------------|
| --- | --- | --- | --- | --- | --- | Peak & AV | H & V |

5. Test Setup Photos of the EUT

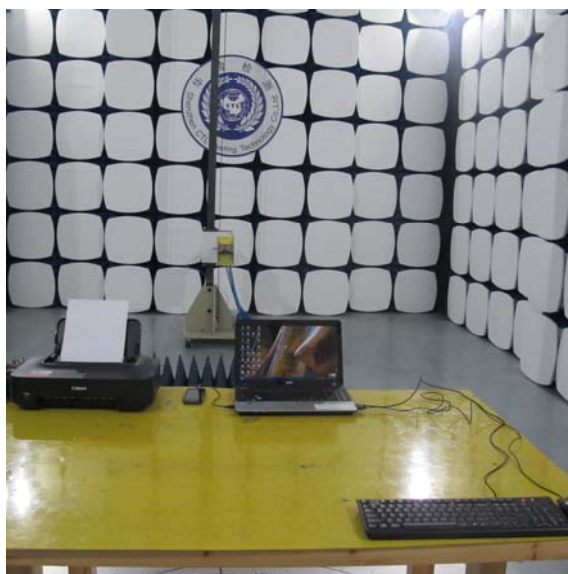

.....End of Report.....