



FCC RADIO TEST REPORT

FCC ID: ROWCDT-XX5370

Product : CDT-XX5370-00-09

Trade Name : N/A

Model Name : B0-9(5370)

Serial Model : K0-9(5370), F0-9(5370), G0-9(5370),
D0-9(5370), A0-9(5370)

Report No. : NTEK- 2012NT1231637F

Prepared for

China Dragon Technology Limited
B4 Bidg, haosan No.1 Industry Park, Shajing street, Bao'an Dist.,
Shenzhen, China

Prepared by

Shenzhen NTEK Testing Technology Co., Ltd.
1/F, Building E, Fenda Science Park, Sanwei Community, Xixiang Street
Bao'an District, Shenzhen P.R. China
Tel.: +86-0755-61156588 Fax.: +86-0755-61156599
Website: www.ntek.org.cn

TEST RESULT CERTIFICATION

Applicant's name : China Dragon Technology Limited
Address : B4 Bidg, haosan No.1 Industry Park, Shajing street, Bao'an Dist.,
Shenzhen, China

Manufacture's Name : China Dragon Technology Limited
Address : B4 Bidg, haosan No.1 Industry Park, Shajing street, Bao'an Dist.,
Shenzhen, China

Product description

Product name..... : CDT-XX5370-00~09

Model and/or type reference : B0-9(5370)

Serial Model : K0-9(5370), F0-9(5370), G0-9(5370), D0-9(5370), A0-9(5370)

Standards : FCC Part15.247

Test procedure ANSI C63.4-2003

This device described above has been tested by NTEK, and the test results show that the equipment under test (EUT) is in compliance with the FCC requirements. And it is applicable only to the tested sample identified in the report.

This report shall not be reproduced except in full, without the written approval of NTEK, this document may be altered or revised by NTEK, personal only, and shall be noted in the revision of the document.

Date of Test :

Date (s) of performance of tests..... : 31 Dec. 2012 ~07 Jan. 2013

Date of Issue..... : 08 Jan. 2013

Test Result..... : **Pass**

Testing Engineer : Apple Huang
(Apple Huang)

Technical Manager : Tom Zhang
(Tom Zhang)

Authorized Signatory : Bovey Yang
(Bovey Yang)

Table of Contents

| | Page |
|---|-------------|
| 1 . SUMMARY OF TEST RESULTS | 5 |
| 1.1 TEST FACILITY | 6 |
| 1.2 MEASUREMENT UNCERTAINTY | 6 |
| 2 . GENERAL INFORMATION | 7 |
| 2.1 GENERAL DESCRIPTION OF EUT | 7 |
| 2.2 DESCRIPTION OF TEST MODES | 9 |
| 2.3 BLOCK DIGRAM SHOWING THE CONFIGURATION OF SYSTEM TESTED | 10 |
| 2.4 DESCRIPTION OF SUPPORT UNITS(CONDUCTED MODE) | 11 |
| 2.5 EQUIPMENTS LIST FOR ALL TEST ITEMS | 12 |
| 3 . EMC EMISSION TEST | 13 |
| 3.1 CONDUCTED EMISSION MEASUREMENT | 13 |
| 3.1.1 POWER LINE CONDUCTED EMISSION LIMITS | 13 |
| 3.1.2 TEST PROCEDURE | 14 |
| 3.1.3 DEVIATION FROM TEST STANDARD | 14 |
| 3.1.4 TEST SETUP | 14 |
| 3.1.5 EUT OPERATING CONDITIONS | 14 |
| 3.1.6 TEST RESULTS | 15 |
| 3.2 RADIATED EMISSION MEASUREMENT | 17 |
| 3.2.1 RADIATED EMISSION LIMITS | 17 |
| 3.2.2 TEST PROCEDURE | 18 |
| 3.2.3 DEVIATION FROM TEST STANDARD | 18 |
| 3.2.4 TEST SETUP | 19 |
| 3.2.5 EUT OPERATING CONDITIONS | 20 |
| 3.2.6 TEST RESULTS (BETWEEN 9KHZ – 30 MHZ) | 21 |
| 3.2.7 TEST RESULTS (BETWEEN 30MHZ – 1GHZ) | 22 |
| 3.2.8 TEST RESULTS (ABOVE 1000 MHZ) | 24 |
| 4 . POWER SPECTRAL DENSITY TEST | 64 |
| 4.1 APPLIED PROCEDURES / LIMIT | 64 |
| 4.1.1 TEST PROCEDURE | 64 |
| 4.1.2 DEVIATION FROM STANDARD | 64 |
| 4.1.3 TEST SETUP | 64 |
| 4.1.4 EUT OPERATION CONDITIONS | 64 |
| 4.1.5 TEST RESULTS | 65 |
| 5 . BANDWIDTH TEST | 73 |
| 5.1 APPLIED PROCEDURES / LIMIT | 73 |
| 5.1.1 TEST PROCEDURE | 73 |

Table of Contents

| | Page |
|---|-------------|
| 5.1.2 DEVIATION FROM STANDARD | 73 |
| 5.1.3 TEST SETUP | 73 |
| 5.1.4 EUT OPERATION CONDITIONS | 73 |
| 5.1.5 TEST RESULTS | 74 |
| 6 . PEAK OUTPUT POWER TEST | 82 |
| 6.1 APPLIED PROCEDURES / LIMIT | 82 |
| 6.1.1 TEST PROCEDURE | 82 |
| 6.1.2 DEVIATION FROM STANDARD | 82 |
| 6.1.3 TEST SETUP | 82 |
| 6.1.4 EUT OPERATION CONDITIONS | 82 |
| 6.1.5 TEST RESULTS | 83 |
| 7 . ANTENNA REQUIREMENT | 84 |
| 7.1 STANDARD REQUIREMENT | 84 |
| 7.2 EUT ANTENNA | 84 |
| 8 . EUT TEST PHOTO | 85 |
| APPENDIX-PHOTOGRAPHS OF EUT CONSTRUCTIONAL DETAILS | |

1. SUMMARY OF TEST RESULTS

Test procedures according to the technical standards:

| FCC Part15 (15.247) , Subpart C | | | |
|--|----------------------------|----------|--------|
| Standard Section | Test Item | Judgment | Remark |
| 15.207 | Conducted Emission | PASS | |
| 15.247 (a)(2) | 6dB Bandwidth | PASS | |
| 15.247 (b) | Peak Output Power | PASS | |
| 15.247 (c) | Radiated Spurious Emission | PASS | |
| 15.247 (d) | Power Spectral Density | PASS | |
| 15.205 | Band Edge Emission | PASS | |
| 15.203 | Antenna Requirement | PASS | |

NOTE:

(1) "N/A" denotes test is not applicable in this Test Report

1.1 TEST FACILITY

NTEK Testing Technology Co., Ltd
 Add.:1/F, Building E, Fenda Science Park, Sanwei Community, Xixiang Street, Bao'an District, Shenzhen P.R. China.
 FCC Registration No.:238937; IC Registration No.:9270A-1
 CNAS Registration No.:L5516

1.2 MEASUREMENT UNCERTAINTY

The reported uncertainty of measurement $y \pm U$, where expanded uncertainty U is based on a standard uncertainty multiplied by a coverage factor of $k=2$, providing a level of confidence of approximately 95 %.

| No. | Item | Uncertainty |
|-----|------------------------------|-------------------------|
| 1 | Conducted Emission Test | $\pm 1.38\text{dB}$ |
| 2 | RF power,conducted | $\pm 0.16\text{dB}$ |
| 3 | Spurious emissions,conducted | $\pm 0.21\text{dB}$ |
| 4 | All emissions,radiated(<1G) | $\pm 4.68\text{dB}$ |
| 5 | All emissions,radiated(>1G) | $\pm 4.89\text{dB}$ |
| 6 | Temperature | $\pm 0.5^\circ\text{C}$ |
| 7 | Humidity | $\pm 2\%$ |

2. GENERAL INFORMATION

2.1 GENERAL DESCRIPTION OF EUT

| | | |
|------------------------|--|---|
| Equipment | CDT-XX5370-00~09 | |
| Trade Name | N/A | |
| Model Name | B0-9(5370) | |
| Serial Model | K0-9(5370), F0-9(5370), G0-9(5370), D0-9(5370), A0-9(5370) | |
| Model Difference | All the model are the same circuit and RF module, except the model name. | |
| Product Description | The EUT is a CDT-XX5370-00~09 | |
| | Operation Frequency: | 802.11b/g/n 20:2412~2462 MHz 802.11n 40: 2422~2452MHz |
| | Modulation Type: | CCK/OFDM/DBPSK/DAPSK |
| | Bit Rate of Transmitter | 802.11b:11/5.5/2/1 Mbps 802.11g:54/48/36/24/18/12/9/6 Mbps 802.11n(20/40MHz):150/144.44/130/117/115.56/104/86.67/78/52/6.5 Mbps |
| | Number Of Channel | 802.11b/g/n20: 11CH 802.11n 40: 7CH |
| | Antenna Designation: | Please see Note 3. |
| | Output Power(PK Conducted): | 802.11b: 12.79 dBm (Max.) 802.11g: 10.65 dBm (Max.) 802.11n20: 10.97 dBm (Max.) 802.11n40: 9.78 dBm (Max.) |
| | Output Power(AV Conducted): | 802.11b: 9.78 dBm 802.11g: 7.43 dBm 802.11n20: 7.31 dBm 802.11n40: 7.11 dBm |
| | Antenna Gain (dBi) | 2.0dbi |
| | Based on the application, features, or specification exhibited in User's Manual, the EUT is considered as an ITE/Computing Device. More details of EUT technical specification, please refer to the User's Manual. | |
| Channel List | Please refer to the Note 2. | |
| power supply | DC 5.0V from PC AC120V/60Hz | |
| Adapter | N/A | |
| Battery | N/A | |
| Connecting I/O Port(s) | Please refer to the User's Manual | |

Note:

1. For a more detailed features description, please refer to the manufacturer's specifications or the User's Manual.

2.

| Channel List for 802.11b/g/n(20MHz) | | | | | | | |
|-------------------------------------|-----------------|---------|-----------------|---------|-----------------|---------|-----------------|
| Channel | Frequency (MHz) | Channel | Frequency (MHz) | Channel | Frequency (MHz) | Channel | Frequency (MHz) |
| 01 | 2412 | 04 | 2427 | 07 | 2442 | 10 | 2457 |
| 02 | 2417 | 05 | 2432 | 08 | 2447 | 11 | 2462 |
| 03 | 2422 | 06 | 2437 | 09 | 2452 | | |

| Channel List for 802.11n(40MHz) | | | | | | | |
|---------------------------------|-----------------|---------|-----------------|---------|-----------------|---------|-----------------|
| Channel | Frequency (MHz) | Channel | Frequency (MHz) | Channel | Frequency (MHz) | Channel | Frequency (MHz) |
| 03 | 2422 | 06 | 2437 | 09 | 2452 | | |
| 04 | 2427 | 07 | 2442 | | | | |
| 05 | 2432 | 08 | 2447 | | | | |

3.

Table for Filed Antenna

| Ant | Brand | Model Name | Antenna Type | Connector | Gain (dBi) | NOTE |
|-----|-------|------------|------------------|-----------|------------|------|
| A | N/A | N/A | External antenna | U-FL | 2.0 | N/A |

2.2 DESCRIPTION OF TEST MODES

To investigate the maximum EMI emission characteristics generates from EUT, the test system was pre-scanning tested base on the consideration of following EUT operation mode or test configuration mode which possible have effect on EMI emission level. Each of these EUT operation mode(s) or test configuration mode(s) mentioned above was evaluated respectively.

| Pretest Mode | Description |
|--------------|---------------------------|
| Mode 1 | 802.11b CH1/ CH6/ CH11 |
| Mode 2 | 802.11g CH1/ CH6/ CH11 |
| Mode 3 | 802.11n(20)CH1/ CH6/ CH11 |
| Mode 4 | 802.11n(40) CH3/ CH6/ CH9 |
| Mode 5 | Link Mode |

| For Conducted Emission | |
|------------------------|-------------|
| Final Test Mode | Description |
| Mode 5 | Link Mode |

| For Radiated Emission | |
|-----------------------|---------------------------|
| Final Test Mode | Description |
| Mode 1 | 802.11b CH1/ CH6/ CH11 |
| Mode 2 | 802.11g CH1/ CH6/ CH11 |
| Mode 3 | 802.11n CH1/ CH6/ CH11 |
| Mode 4 | 802.11n(40) CH3/ CH6/ CH9 |

Note:

- (1) The measurements are performed at the highest, middle, lowest available channels.
- (2) The measurements are performed at all Bit Rate of Transmitter, the worst data was reported

2.3 BLOCK DIGRAM SHOWING THE CONFIGURATION OF SYSTEM TESTED

Conducted Emission Test

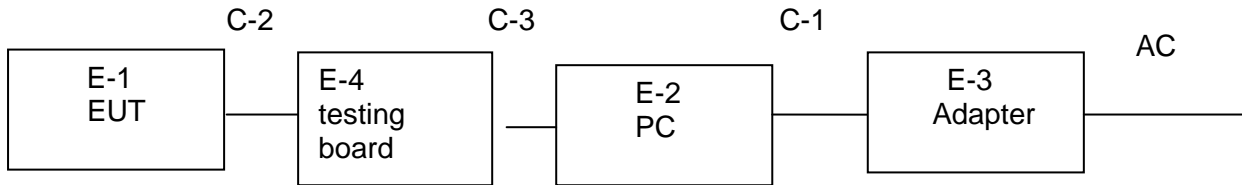

Radiated Spurious Emission Test

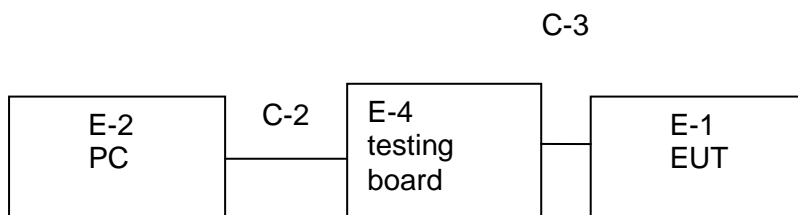

2.4 DESCRIPTION OF SUPPORT UNITS(CONDUCTED MODE)

The EUT has been tested as an independent unit together with other necessary accessories or support units. The following support units or accessories were used to form a representative test configuration during the tests.

| Item | Equipment | Mfr/Brand | Model/Type No. | Series No. | Note |
|------|-------------------|-----------|----------------|------------|------|
| E-1 | CDT-XX5370-00~09 | N/A | B0-9(5370) | N/A | EUT |
| E-2 | Notebook computer | IBM | 2366 | N/A | |
| E-3 | Adapter | IBM | 08K8202 | N/A | |
| E-4 | Testing board | N/A | USB COM | N/A | |
| | | | | | |
| | | | | | |

| Item | Shielded Type | Ferrite Core | Length | Note |
|------|---------------|--------------|--------|------|
| C-1 | NO | NO | 0.8M | |
| C-2 | NO | NO | 1.0M | |
| | | | | |
| | | | | |
| | | | | |

Note:

- (1) The support equipment was authorized by Declaration of Confirmation.
- (2) For detachable type I/O cable should be specified the length in cm in 『Length』 column.

2.5 EQUIPMENTS LIST FOR ALL TEST ITEMS

Radiation Test equipment

| Item | Kind of Equipment | Manufacturer | Type No. | Serial No. | Calibrated until |
|------|--------------------|--------------|-------------|------------|------------------|
| 1 | Spectrum Analyzer | Agilent | E4407B | 160400005 | Jul. 06. 2013 |
| 2 | Test Receiver | R&S | ESPI | 101318 | Jul. 06. 2013 |
| 3 | Bilog Antenna | TESEQ | CBL6111D | 31216 | Jul. 06. 2013 |
| 4 | 50Ω Coaxial Switch | Anritsu | MP59B | 6200264416 | Jul. 06. 2013 |
| 5 | Spectrum Analyzer | ADVANTEST | R3132 | 150900201 | Jul. 06. 2013 |
| 6 | Horn Antenna | EM | EM-AH-10180 | 2011071402 | Jul. 06. 2013 |
| 7 | Horn Ant | Schwarzbeck | BBHA 9170 | 9170-181 | Jul. 06. 2013 |
| 8 | Amplifier | EM | EM-30180 | 060538 | Jul. 06. 2013 |
| 9 | Loop Antenna | ARA | PLA-1030/B | 1029 | Jul. 06. 2013 |
| 10 | Power Meter | R&S | NRVS | 100696 | Jul. 06. 2013 |

Conduction Test equipment

| Item | Kind of Equipment | Manufacturer | Type No. | Serial No. | Calibrated until |
|------|-----------------------|--------------|----------|------------|------------------|
| 1 | Test Receiver | R&S | ESCI | 101160 | Jul. 06. 2013 |
| 2 | LISN | R&S | ENV216 | 101313 | Jul. 06. 2013 |
| 3 | LISN | EMCO | 3816/2 | 00042990 | Jul. 06. 2013 |
| 4 | 50Ω Coaxial Switch | Anritsu | MP59B | 6200264417 | Jul. 06. 2013 |
| 5 | Passive Voltage Probe | R&S | ESH2-Z3 | 100196 | Jul. 06. 2013 |
| 6 | Absorbing clamp | R&S | MOS-21 | 100423 | Jul. 06. 2013 |

3. EMC EMISSION TEST

3.1 CONDUCTED EMISSION MEASUREMENT

3.1.1 POWER LINE CONDUCTED EMISSION Limits (Frequency Range 150KHz-30MHz)

| FREQUENCY (MHz) | Class A (dBuV) | | Class B (dBuV) | | Standard |
|-----------------|----------------|---------|----------------|-----------|----------|
| | Quasi-peak | Average | Quasi-peak | Average | |
| 0.15 -0.5 | 79.00 | 66.00 | 66 - 56 * | 56 - 46 * | CISPR |
| 0.50 -5.0 | 73.00 | 60.00 | 56.00 | 46.00 | CISPR |
| 5.0 -30.0 | 73.00 | 60.00 | 60.00 | 50.00 | CISPR |

| | | | | | |
|-----------|-------|-------|-----------|-----------|-----|
| 0.15 -0.5 | 79.00 | 66.00 | 66 - 56 * | 56 - 46 * | FCC |
| 0.50 -5.0 | 73.00 | 60.00 | 56.00 | 46.00 | FCC |
| 5.0 -30.0 | 73.00 | 60.00 | 60.00 | 50.00 | FCC |

Note:

- (1) The tighter limit applies at the band edges.
- (2) The limit of " * " marked band means the limitation decreases linearly with the logarithm of the frequency in the range.

The following table is the setting of the receiver

| Receiver Parameters | Setting |
|---------------------|----------|
| Attenuation | 10 dB |
| Start Frequency | 0.15 MHz |
| Stop Frequency | 30 MHz |
| IF Bandwidth | 9 kHz |

3.1.2 TEST PROCEDURE

- a. The EUT was placed 0.4 meters from the horizontal ground plane with EUT being connected to the power mains through a line impedance stabilization network (LISN). All other support equipments powered from additional LISN(s). The LISN provide 50 Ohm/ 50uH of coupling impedance for the measuring instrument.
- b. Interconnecting cables that hang closer than 40 cm to the ground plane shall be folded back and forth in the center forming a bundle 30 to 40 cm long.
- c. I/O cables that are not connected to a peripheral shall be bundled in the center. The end of the cable may be terminated, if required, using the correct terminating impedance. The overall length shall not exceed 1 m.
- d. LISN at least 80 cm from nearest part of EUT chassis.
- e. For the actual test configuration, please refer to the related Item –EUT Test Photos.

3.1.3 DEVIATION FROM TEST STANDARD

No deviation

3.1.4 TEST SETUP

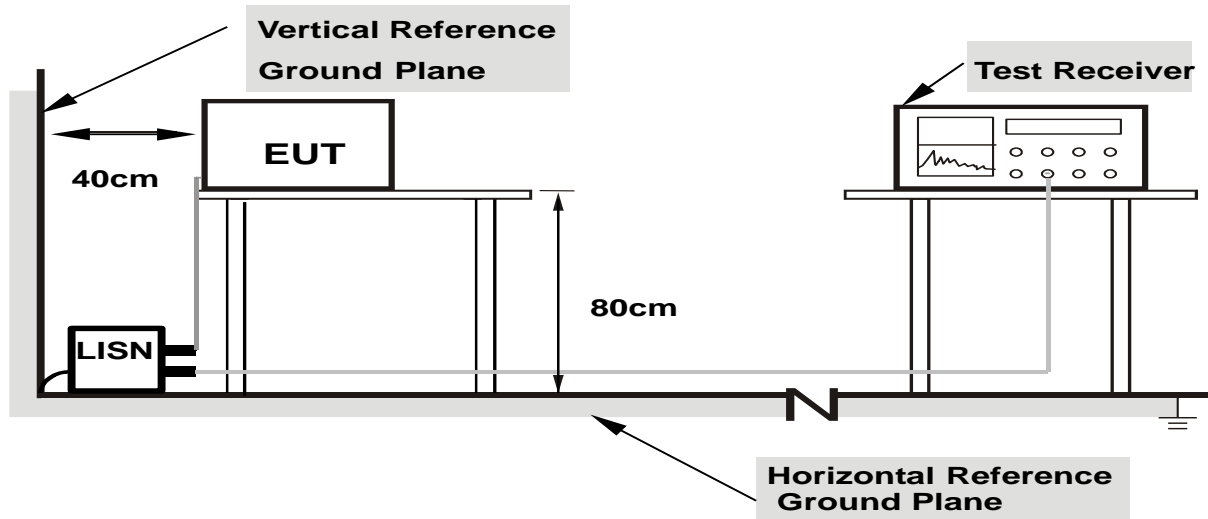

- Note:**
- 1.Support units were connected to second LISN.
 - 2.Both of LISNs (AMN) are 80 cm from EUT and at least 80 from other units and other metal planes

3.1.5 EUT OPERATING CONDITIONS

The EUT was configured for testing in a typical fashion (as a customer would normally use it). The EUT has been programmed to continuously transmit during test. This operating condition was tested and used to collect the included data.

3.1.6 TEST RESULTS

| | | | |
|----------------|-----------------------------|---------------------|------------|
| EUT : | CDT-XX5370-00~09 | Model Name. : | B0-9(5370) |
| Temperature : | 26 °C | Relative Humidity : | 54% |
| Pressure : | 1010hPa | Phase : | L |
| Test Voltage : | DC 5.0V from PC AC120V/60Hz | Test Mode : | Mode 5 |

| Frequency (MHz) | Meter Reading (dBμV) | Factor (dB) | Emission Level (dBμV) | Limits (dBμV) | Margin (dB) | Detector Type |
|--------------------|-------------------------|----------------|--------------------------|------------------|----------------|---------------|
| 0.166 | 50.93 | 9.81 | 60.74 | 65.15 | -4.41 | QP |
| 0.166 | 35.24 | 9.81 | 45.05 | 55.15 | -10.1 | AVG |
| 0.762 | 38.57 | 10.2 | 48.77 | 56 | -7.23 | QP |
| 1.0859 | 33.29 | 10.16 | 43.45 | 46 | -2.55 | AVG |
| 3.034 | 39.53 | 10.3 | 49.83 | 56 | -6.17 | QP |
| 3.034 | 32.22 | 10.3 | 42.52 | 46 | -3.48 | AVG |

Remark:

1. All readings are Quasi-Peak and Average values.
2. Factor = Insertion Loss + Cable Loss.

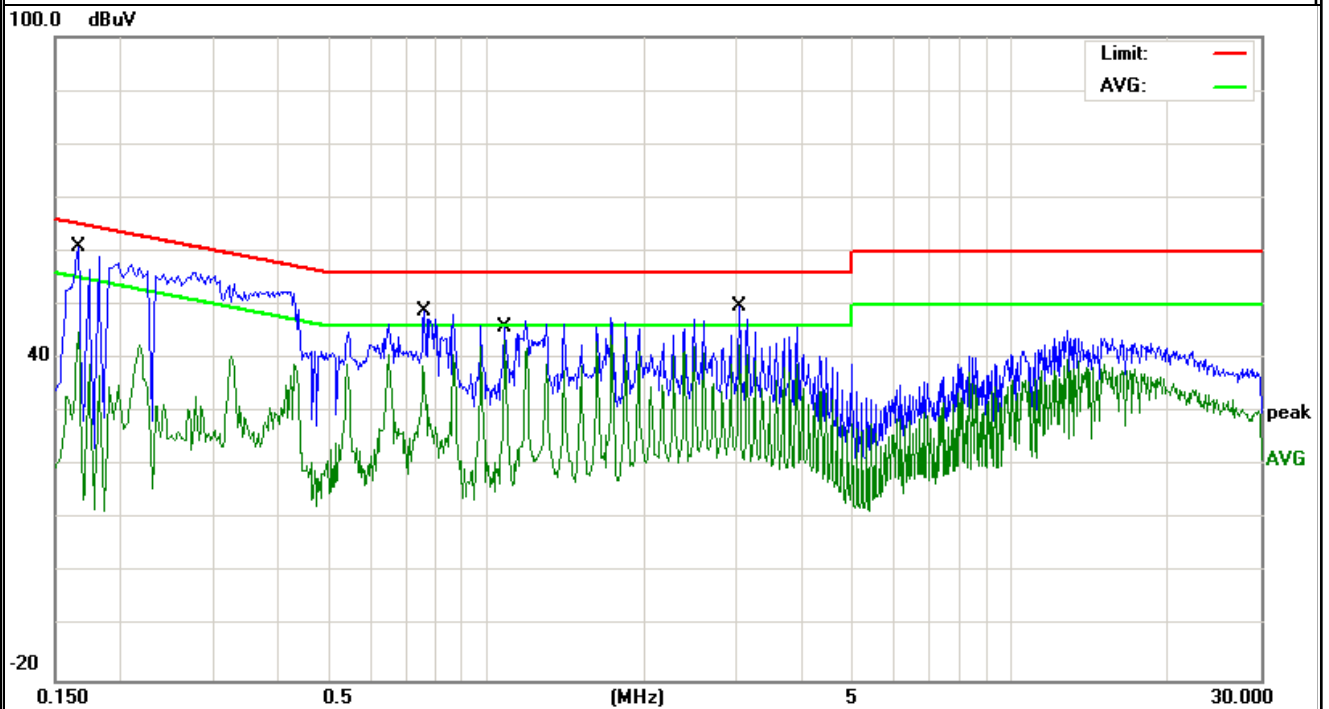

| | | | |
|----------------|-----------------------------|---------------------|------------|
| EUT : | CDT-XX5370-00~09 | Model Name. : | B0-9(5370) |
| Temperature : | 26 °C | Relative Humidity : | 54% |
| Pressure : | 1010hPa | Phase : | N |
| Test Voltage : | DC 5.0V from PC AC120V/60Hz | Test Mode : | Mode 5 |

| Frequency (MHz) | Meter Reading (dBμV) | Factor (dB) | Emission Level (dBμV) | Limits (dBμV) | Margin (dB) | Detector Type |
|-----------------|----------------------|-------------|-----------------------|---------------|-------------|---------------|
| 0.178 | 49.57 | 9.79 | 59.36 | 64.57 | -5.21 | QP |
| 0.218 | 34.69 | 9.8 | 44.49 | 52.89 | -8.4 | AVG |
| 0.326 | 35.64 | 9.95 | 45.59 | 49.55 | -3.96 | AVG |
| 0.358 | 43.47 | 10 | 53.47 | 58.77 | -5.3 | QP |
| 3.142 | 39.84 | 10.3 | 50.14 | 56 | -5.86 | QP |
| 3.142 | 29.95 | 10.3 | 40.25 | 46 | -5.75 | AVG |

Remark:

1. All readings are Quasi-Peak and Average values.
2. Factor = Insertion Loss + Cable Loss.

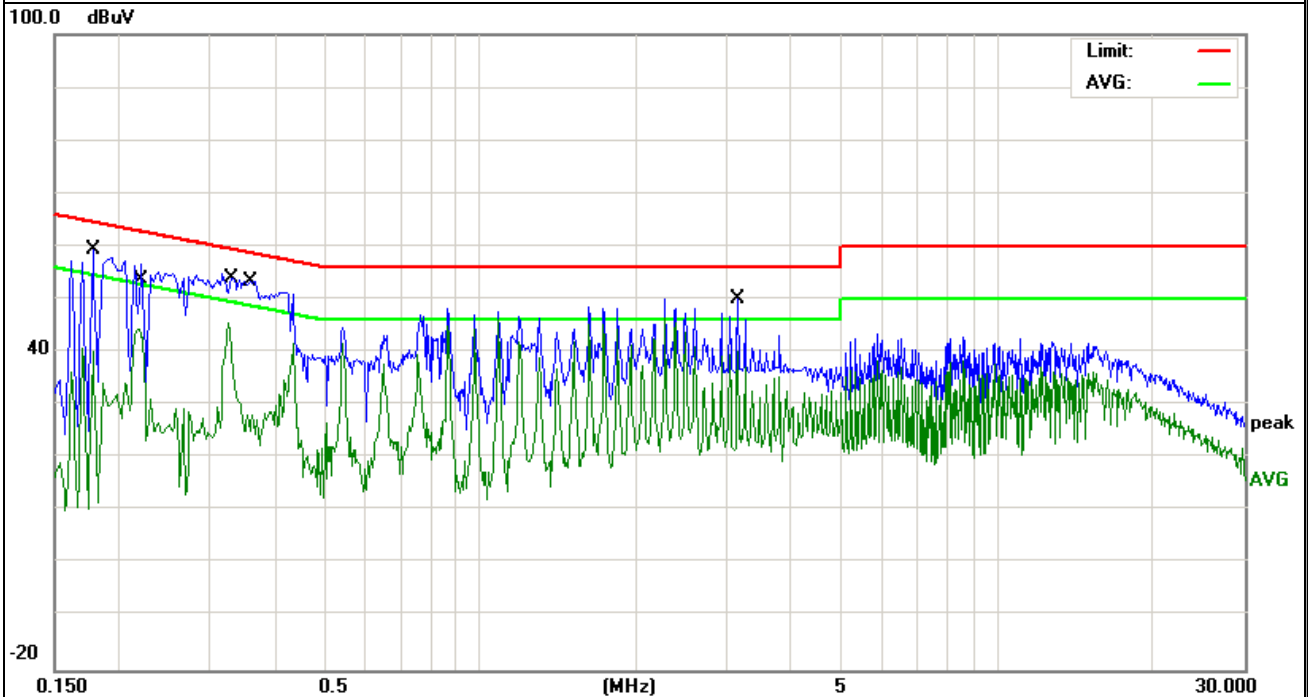

3.2 RADIATED EMISSION MEASUREMENT

3.2.1 RADIATED EMISSION LIMITS (Frequency Range 9kHz-1000MHz)

20dBc in any 100 kHz bandwidth outside the operating frequency band. In case the emission fall within the restricted band specified on 15.205(a), then the 15.209(a) limit in the table below has to be followed.

| Frequencies (MHz) | Field Strength (microrvolts/meter) | Measurement Distance (meters) |
|-------------------|------------------------------------|-------------------------------|
| 0.009~0.490 | 2400/F(KHz) | 300 |
| 0.490~1.705 | 24000/F(KHz) | 30 |
| 1.705~30.0 | 30 | 30 |
| 30~88 | 100 | 3 |
| 88~216 | 150 | 3 |
| 216~960 | 200 | 3 |
| Above 960 | 500 | 3 |

LIMITS OF RADIATED EMISSION MEASUREMENT (Above 1000MHz)

| FREQUENCY (MHz) | Class A (dBuV/m) (at 3M) | | Class B (dBuV/m) (at 3M) | |
|-----------------|--------------------------|---------|--------------------------|---------|
| | PEAK | AVERAGE | PEAK | AVERAGE |
| Above 1000 | 80 | 60 | 74 | 54 |

Notes:

- (1) The limit for radiated test was performed according to FCC PART 15C.
- (2) The tighter limit applies at the band edges.
- (3) Emission level (dBuV/m)=20log Emission level (uV/m).

| Spectrum Parameter | Setting |
|---------------------------------------|--|
| Attenuation | Auto |
| Start Frequency | 1000 MHz |
| Stop Frequency | 10th carrier harmonic |
| RB / VB (emission in restricted band) | 1 MHz / 1 MHz for Peak, 1 MHz / 10Hz for Average |

| Receiver Parameter | Setting |
|------------------------|----------------------------------|
| Attenuation | Auto |
| Start ~ Stop Frequency | 9kHz~150kHz / RB 200Hz for QP |
| Start ~ Stop Frequency | 150kHz~30MHz / RB 9kHz for QP |
| Start ~ Stop Frequency | 30MHz~1000MHz / RB 120kHz for QP |

3.2.2 TEST PROCEDURE

- a. The measuring distance of at 3 m shall be used for measurements at frequency up to 1GHz. For frequencies above 1GHz, any suitable measuring distance may be used.
- b. The EUT was placed on the top of a rotating table 0.8 meters above the ground at a 3 meter open area test site. The table was rotated 360 degrees to determine the position of the highest radiation.
- c. The height of the equipment or of the substitution antenna shall be 0.8 m; the height of the test antenna shall vary between 1 m to 4 m. Both horizontal and vertical polarizations of the antenna are set to make the measurement.
- d. The initial step in collecting conducted emission data is a spectrum analyzer peak detector mode pre-scanning the measurement frequency range. Significant peaks are then marked and then Quasi Peak detector mode re-measured.
- e. If the Peak Mode measured value compliance with and lower than Quasi Peak Mode Limit, the EUT shall be deemed to meet QP Limits and then no additional QP Mode measurement performed.
- f. For the actual test configuration, please refer to the related Item –EUT Test Photos.

Note:

Both horizontal and vertical antenna polarities were tested and performed pretest to three orthogonal axis. The worst case emissions were reported

3.2.3 DEVIATION FROM TEST STANDARD

No deviation

3.2.4 TEST SETUP

(A) Radiated Emission Test-Up Frequency Below 30MHz

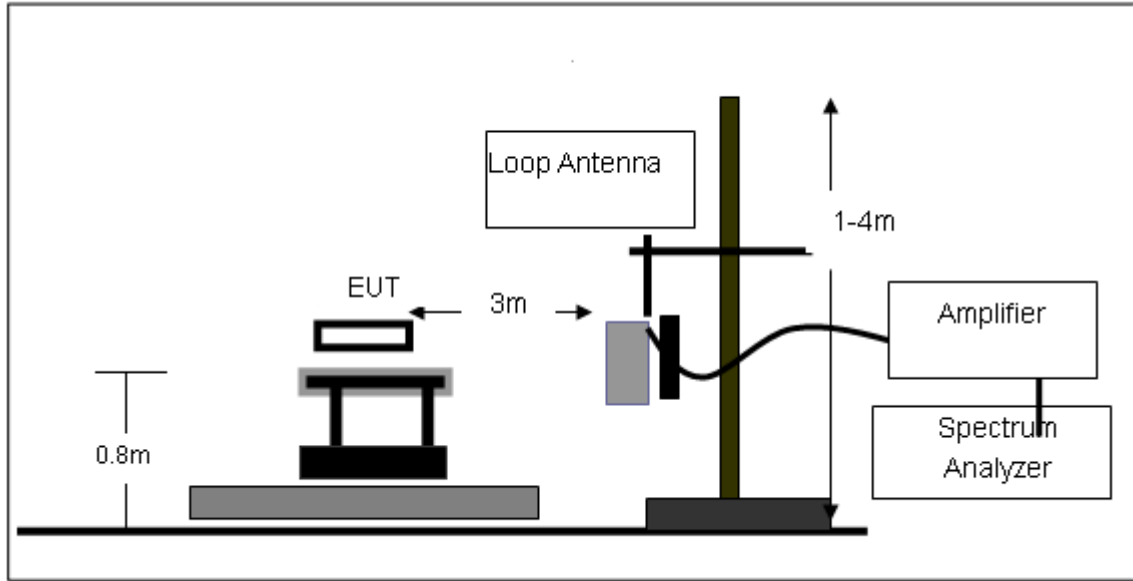

(B) Radiated Emission Test-Up Frequency 30MHz~1GHz

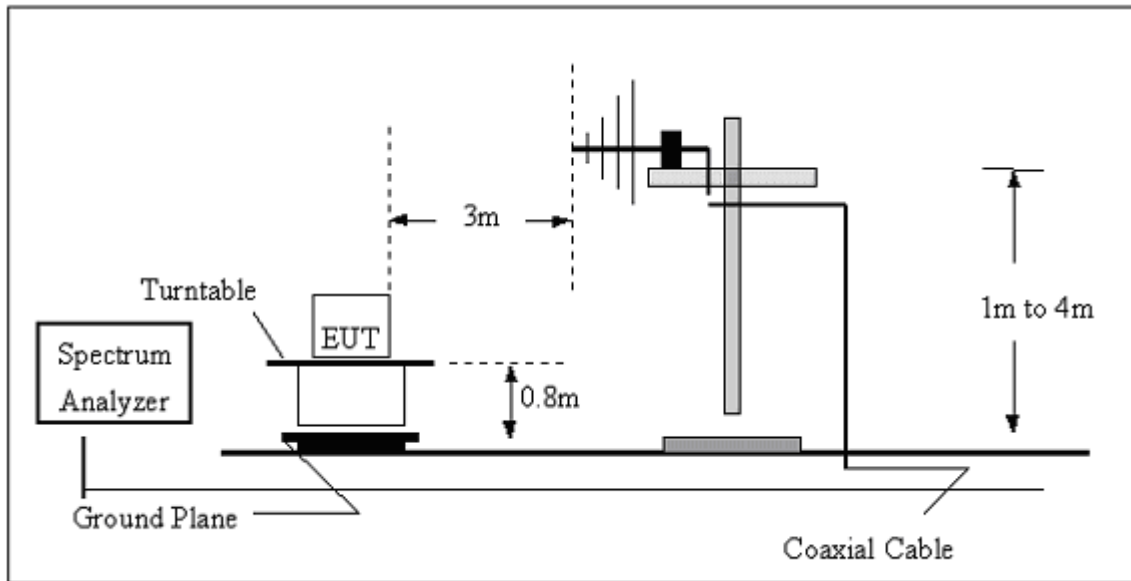

(C) Radiated Emission Test-Up Frequency Above 1GHz

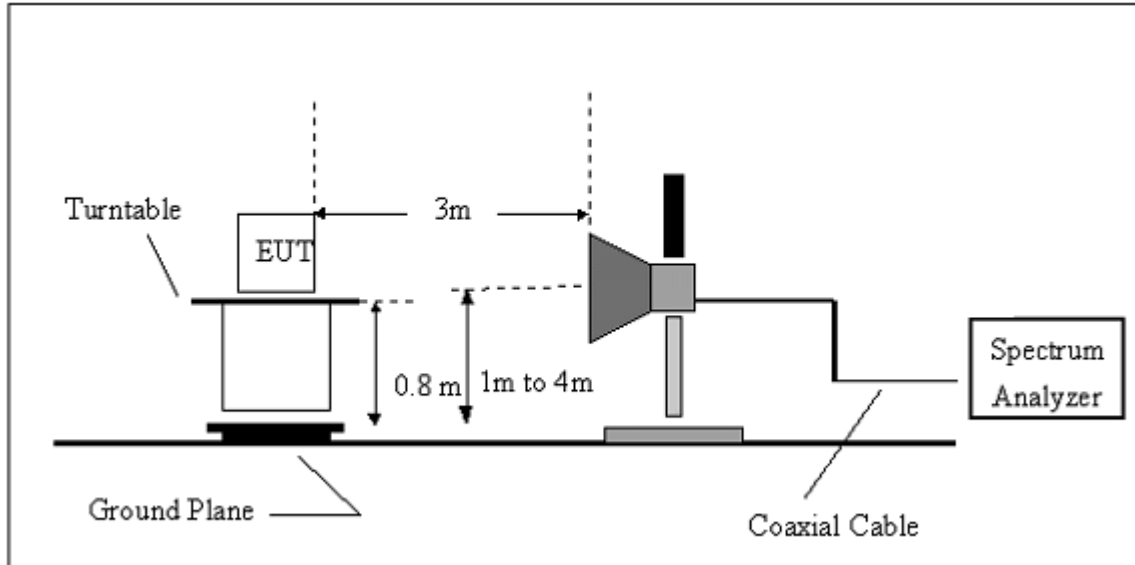

3.2.5 EUT OPERATING CONDITIONS

The EUT tested system was configured as the statements of 2.4 Unless otherwise a special operating condition is specified in the follows during the testing.

3.2.6 TEST RESULTS (BETWEEN 9KHZ – 30 MHZ)

| | | | |
|--------------|------------------|--------------------|------------|
| EUT: | CDT-XX5370-00~09 | Model Name. : | B0-9(5370) |
| Temperature: | 20 °C | Relative Humidity: | 48% |
| Pressure: | 1010 hPa | Test Voltage : | DC 5.0V |
| Test Mode : | TX | Polarization : | -- |

| Freq. (MHz) | Reading (dBuV/m) | Limit (dBuV/m) | Margin (dB) | State P/F |
|----------------|---------------------|-------------------|----------------|--------------|
| -- | -- | -- | -- | PASS |
| -- | -- | -- | -- | PASS |

NOTE:

The amplitude of spurious emissions which are attenuated by more than 20dB below the permissible value has no need to be reported.

Distance extrapolation factor = $20 \log (\text{specific distance}/\text{test distance})(\text{dB})$;

Limit line = specific limits(dBuv) + distance extrapolation factor.

3.2.7 TEST RESULTS (BETWEEN 30MHZ – 1GHZ)

| | | | |
|---------------|------------------|---------------------|------------|
| EUT : | CDT-XX5370-00~09 | Model Name : | B0-9(5370) |
| Temperature : | 20 °C | Relative Humidity : | 48% |
| Pressure : | 1010 hPa | Test Voltage : | DC 5.0V |
| Test Mode : | TX | Polarization : | Horizontal |

| Frequency (MHz) | Meter Reading (dBμV) | Factor (dB) | Emission Level (dBμV/m) | Limits (dBμV/m) | Margin (dB) | Detector Type |
|-----------------|----------------------|-------------|-------------------------|-----------------|-------------|---------------|
| 167.2366 | 23.18 | 10.26 | 33.44 | 43.5 | -10.06 | QP |
| 211.5264 | 25.04 | 9.36 | 34.4 | 43.5 | -9.1 | QP |
| 341.9786 | 22.8 | 15.15 | 37.95 | 46 | -8.05 | QP |
| 675.2078 | 17.54 | 22.15 | 39.69 | 46 | -6.31 | QP |

Remark:
Factor = Antenna Factor + Cable Loss – Pre-amplifier.

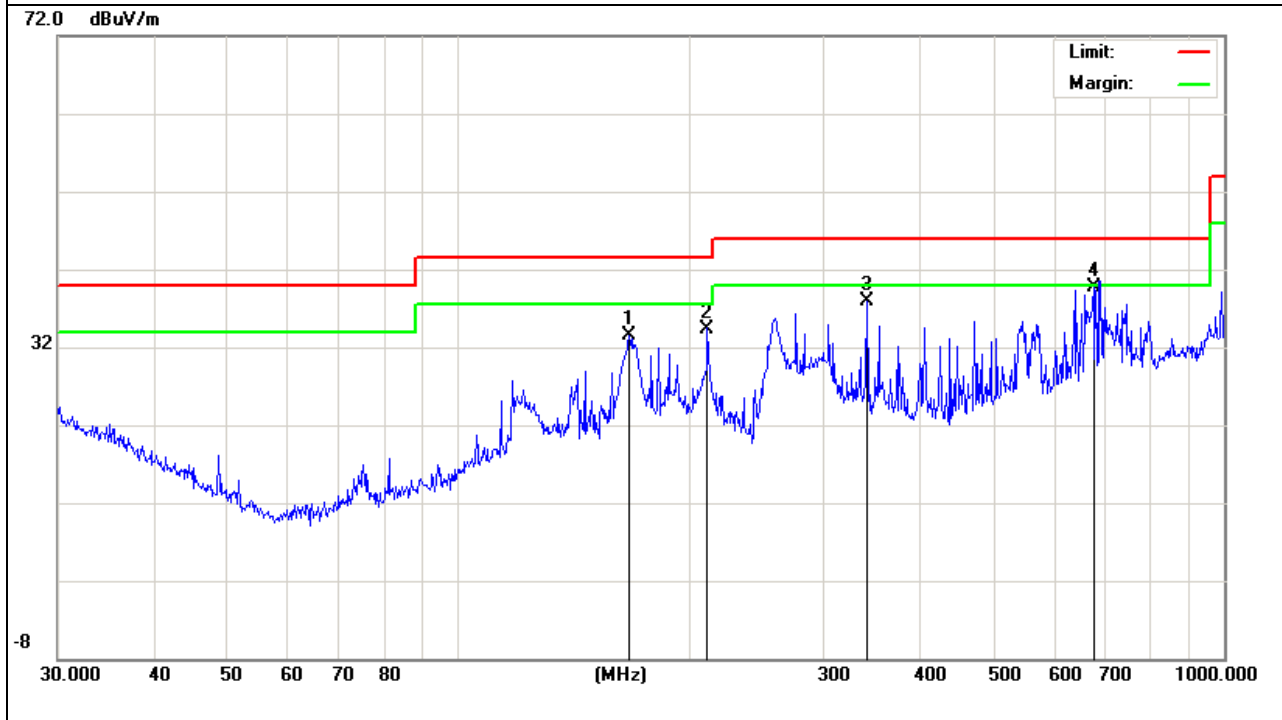

| | | | |
|---------------|------------------|---------------------|------------|
| EUT : | CDT-XX5370-00~09 | Model Name : | B0-9(5370) |
| Temperature : | 20 °C | Relative Humidity : | 48% |
| Pressure : | 1010 hPa | Test Voltage : | DC 5.0V |
| Test Mode : | TX | Polarization : | Vertical |

| Frequency (MHz) | Meter Reading (dBμV) | Factor (dB) | Emission Level (dBμV/m) | Limits (dBμV/m) | Margin (dB) | Detector Type |
|-----------------|----------------------|-------------|-------------------------|-----------------|-------------|---------------|
| 119.8555 | 22.06 | 11.77 | 33.83 | 43.5 | -9.67 | QP |
| 495.9343 | 17.03 | 19.3 | 36.33 | 46 | -9.67 | QP |
| 549.0193 | 18.83 | 21.83 | 40.66 | 46 | -5.34 | QP |
| 670.4892 | 17.07 | 22.08 | 39.15 | 46 | -6.85 | QP |
| | | | | | | |

Remark:

Factor = Antenna Factor + Cable Loss – Pre-amplifier.

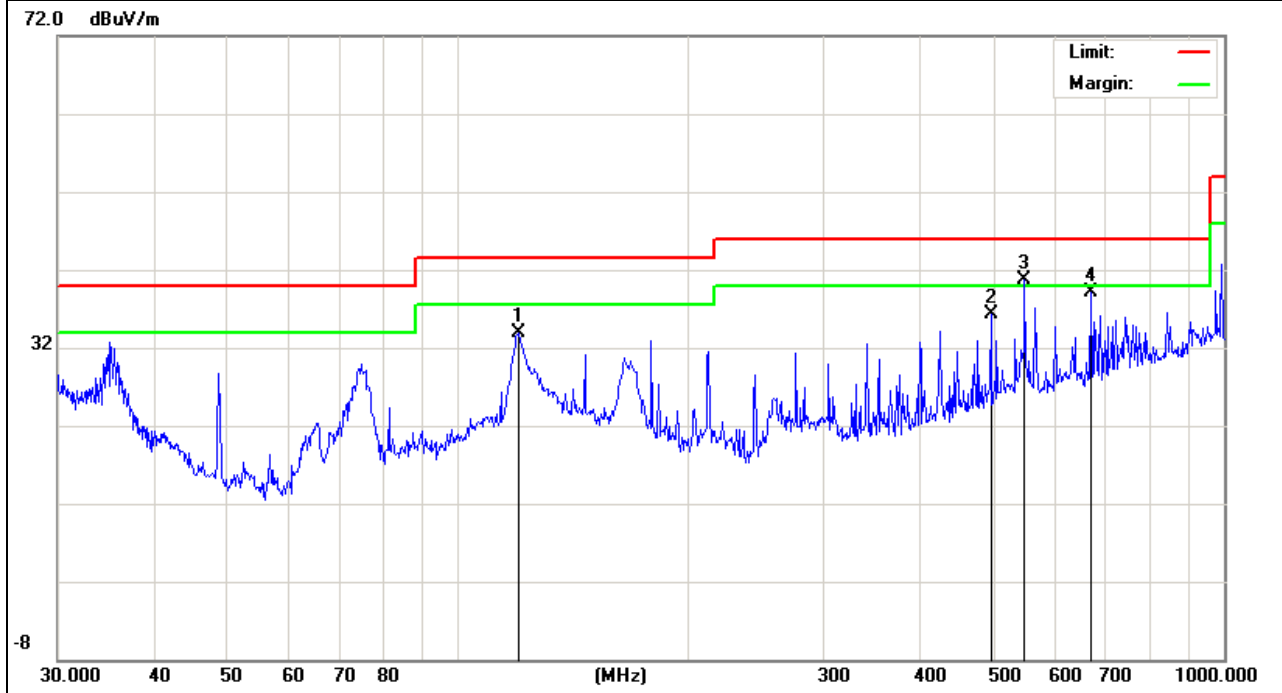

3.2.8 TEST RESULTS (ABOVE 1000 MHZ)

| | | | |
|---------------|-------------------------|---------------------|------------|
| EUT : | CDT-XX5370-00~09 | Model Name : | B0-9(5370) |
| Temperature : | 20 °C | Relative Humidity : | 48% |
| Pressure : | 1010 hPa | Test Voltage : | DC 5.0V |
| Test Mode : | CH1 (802.11b Mode)/2412 | Polarization : | Horizontal |

| Frequency (MHz) | Meter Reading (dBμV) | Factor (dB) | Emission Level (dBμV/m) | Limits (dBμV/m) | Margin (dB) | Detector Type |
|-----------------|----------------------|-------------|-------------------------|-----------------|-------------|---------------|
| 4824.146 | 50.81 | 10.44 | 61.25 | 74 | -12.75 | peak |
| 4824.146 | 33.24 | 10.44 | 43.68 | 54 | -10.32 | AVG |
| 7236.145 | 44.24 | 12.39 | 56.63 | 74 | -17.37 | peak |
| 7236.145 | 29.15 | 12.39 | 41.54 | 54 | -12.46 | AVG |
| | | | | | | |
| | | | | | | |
| | | | | | | |
| | | | | | | |

Remark:
Factor = Antenna Factor + Cable Loss – Pre-amplifier.

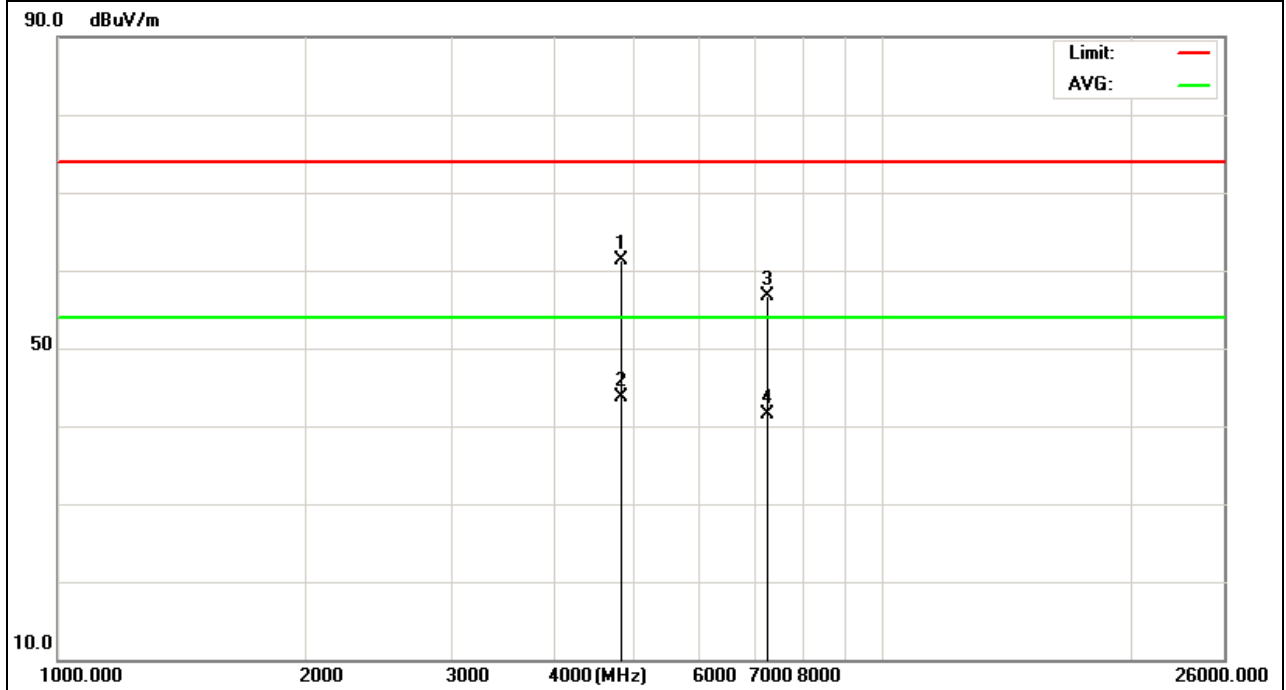

| | | | |
|---------------|-------------------------|---------------------|------------|
| EUT : | CDT-XX5370-00~09 | Model Name : | B0-9(5370) |
| Temperature : | 20 °C | Relative Humidity : | 48% |
| Pressure : | 1010 hPa | Test Voltage : | DC 5.0V |
| Test Mode : | CH1 (802.11b Mode)/2412 | Polarization : | Vertical |

| Frequency (MHz) | Meter Reading (dBμV) | Factor (dB) | Emission Level (dBμV/m) | Limits (dBμV/m) | Margin (dB) | Detector Type |
|--------------------|-------------------------|----------------|----------------------------|--------------------|----------------|---------------|
| 4874.141 | 51.25 | 10.4 | 61.65 | 74 | -12.35 | peak |
| 4874.141 | 32.44 | 10.4 | 42.84 | 54 | -11.16 | AVG |
| 7311.159 | 42.82 | 12.75 | 55.57 | 74 | -18.43 | peak |
| 7311.159 | 27.67 | 12.75 | 40.42 | 54 | -13.58 | AVG |
| | | | | | | |
| | | | | | | |
| | | | | | | |
| | | | | | | |

Remark:
Factor = Antenna Factor + Cable Loss – Pre-amplifier.

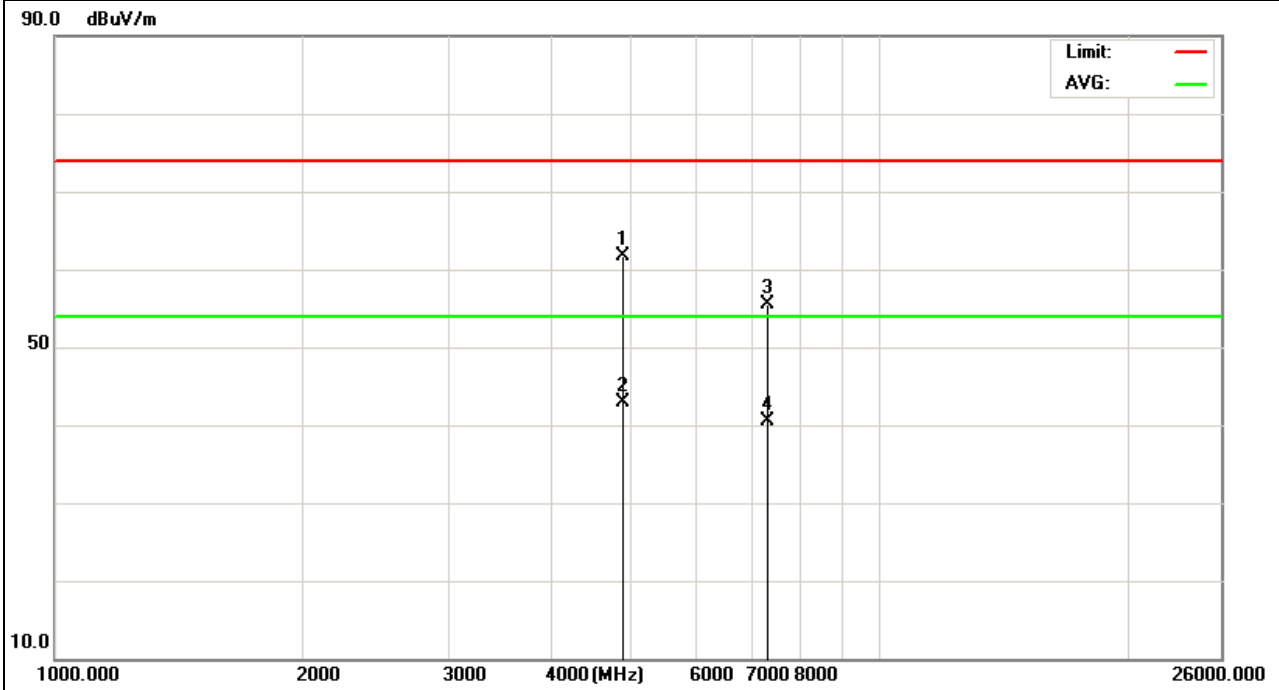

| | | | |
|---------------|-------------------------|---------------------|------------|
| EUT : | CDT-XX5370-00~09 | Model Name : | B0-9(5370) |
| Temperature : | 20 °C | Relative Humidity : | 48% |
| Pressure : | 1010 hPa | Test Voltage : | DC 5.0V |
| Test Mode : | CH6 (802.11b Mode)/2437 | Polarization : | Horizontal |

| Frequency (MHz) | Meter Reading (dBμV) | Factor (dB) | Emission Level (dBμV/m) | Limits (dBμV/m) | Margin (dB) | Detector Type |
|-----------------|----------------------|-------------|-------------------------|-----------------|-------------|---------------|
| 4874.155 | 50.16 | 10.4 | 60.56 | 74 | -13.44 | peak |
| 4874.155 | 33.11 | 10.4 | 43.51 | 54 | -10.49 | AVG |
| 7311.132 | 42.45 | 12.75 | 55.2 | 74 | -18.8 | peak |
| 7311.132 | 27.63 | 12.75 | 40.38 | 54 | -13.62 | AVG |
| | | | | | | |
| | | | | | | |

Remark:
 Factor = Antenna Factor + Cable Loss – Pre-amplifier.

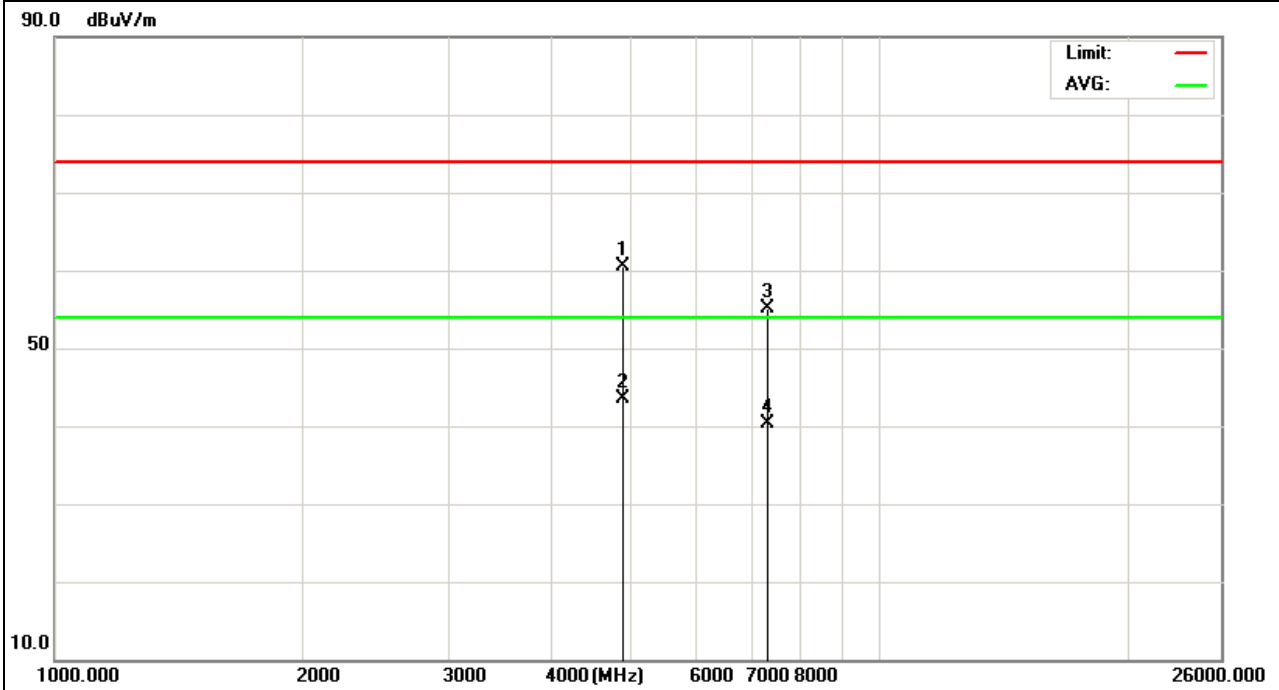

| | | | |
|---------------|-------------------------|---------------------|------------|
| EUT : | CDT-XX5370-00~09 | Model Name : | B0-9(5370) |
| Temperature : | 20 °C | Relative Humidity : | 48% |
| Pressure : | 1010 hPa | Test Voltage : | DC 5.0V |
| Test Mode : | CH6 (802.11b Mode)/2437 | Polarization : | Vertical |

| Frequency (MHz) | Meter Reading (dBμV) | Factor (dB) | Emission Level (dBμV/m) | Limits (dBμV/m) | Margin (dB) | Detector Type |
|-----------------|----------------------|-------------|-------------------------|-----------------|-------------|---------------|
| 4924.142 | 52.2 | 10.39 | 62.59 | 74 | -11.41 | peak |
| 4934.142 | 33.04 | 10.44 | 43.48 | 54 | -10.52 | AVG |
| 7386.139 | 42.69 | 12.68 | 55.37 | 74 | -18.63 | peak |
| 7386.139 | 28.76 | 12.68 | 41.44 | 54 | -12.56 | AVG |
| | | | | | | |
| | | | | | | |

Remark:

- Factor = Antenna Factor + Cable Loss – Pre-amplifier.
- No emission detected above 18GHz

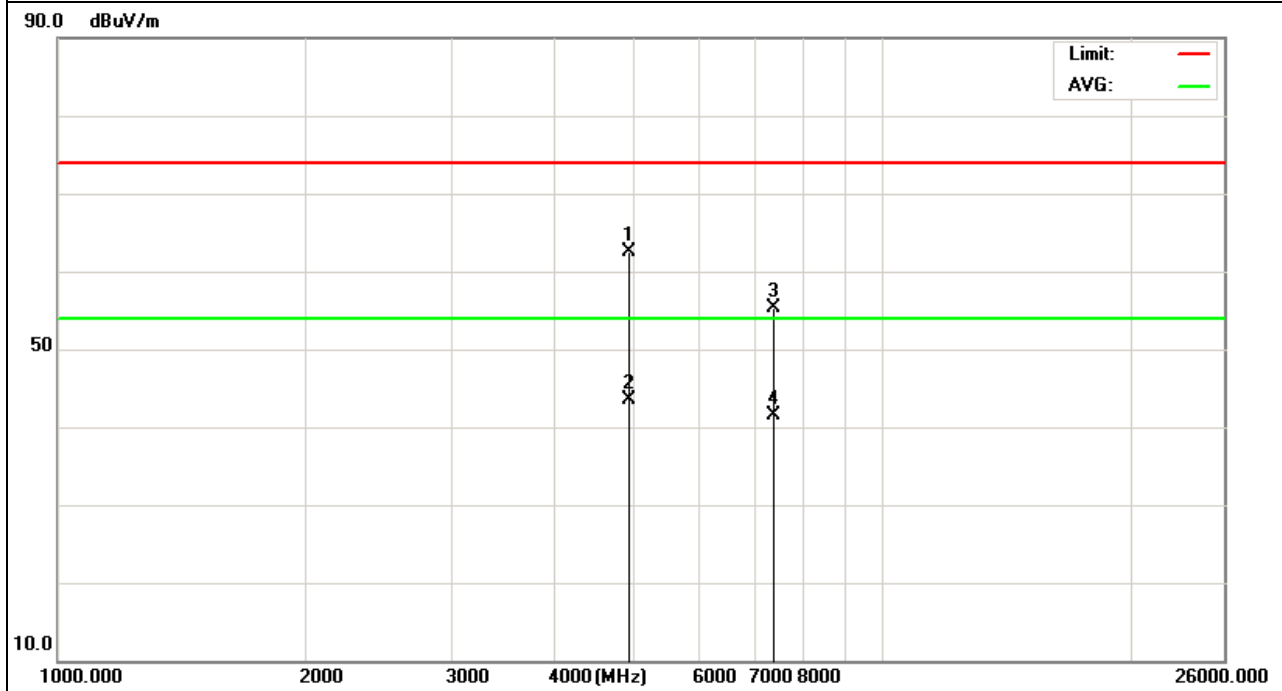

| | | | |
|---------------|--------------------------|---------------------|------------|
| EUT : | CDT-XX5370-00~09 | Model Name : | B0-9(5370) |
| Temperature : | 20 °C | Relative Humidity : | 48% |
| Pressure : | 1010 hPa | Test Voltage : | DC 5.0V |
| Test Mode : | CH11 (802.11b Mode)/2462 | Polarization : | Horizontal |

| Frequency (MHz) | Meter Reading (dBμV) | Factor (dB) | Emission Level (dBμV/m) | Limits (dBμV/m) | Margin (dB) | Detector Type |
|-----------------|----------------------|-------------|-------------------------|-----------------|-------------|---------------|
| 4924.141 | 51.15 | 10.39 | 61.54 | 74 | -12.46 | peak |
| 4924.141 | 33.07 | 10.39 | 43.46 | 54 | -10.54 | AVG |
| 7386.138 | 42.6 | 12.68 | 55.28 | 74 | -18.72 | peak |
| 7386.138 | 28 | 12.68 | 40.68 | 54 | -13.32 | AVG |
| | | | | | | |
| | | | | | | |
| | | | | | | |
| | | | | | | |

Remark:

- Factor = Antenna Factor + Cable Loss – Pre-amplifier.
- No emission detected above 18GHz

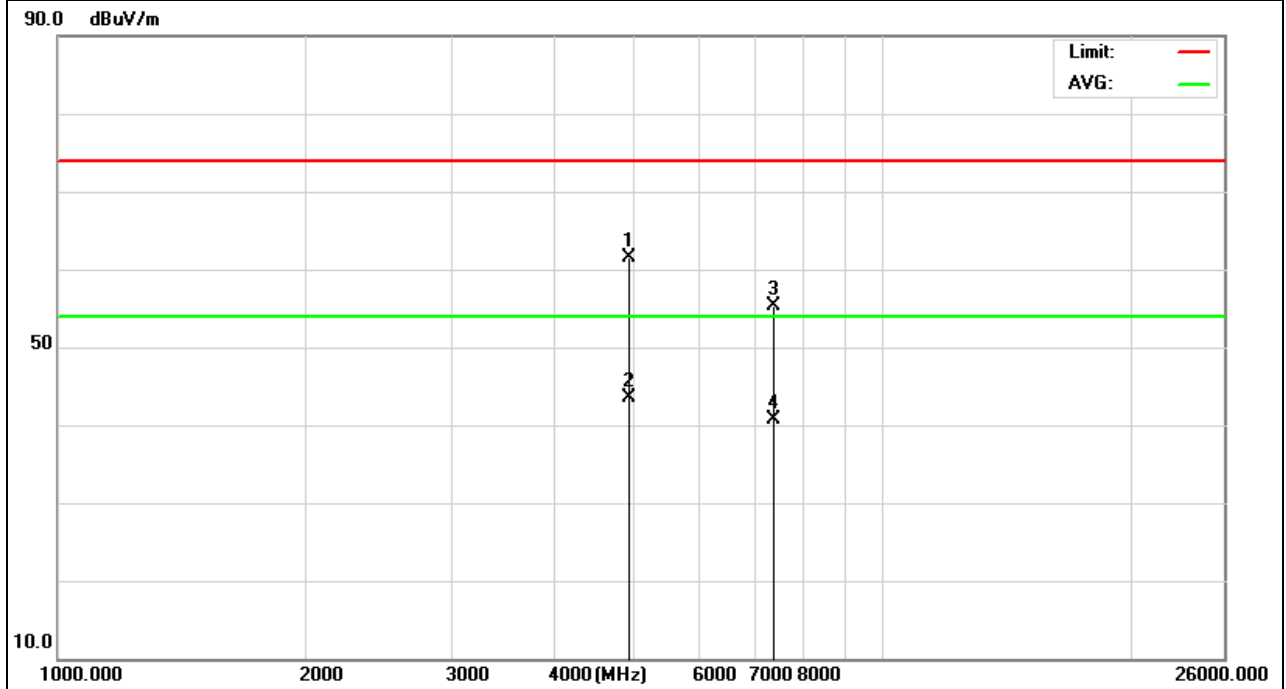

| | | | |
|---------------|--------------------------|---------------------|------------|
| EUT : | CDT-XX5370-00~09 | Model Name : | B0-9(5370) |
| Temperature : | 20 °C | Relative Humidity : | 48% |
| Pressure : | 1010 hPa | Test Voltage : | DC 5.0V |
| Test Mode : | CH11 (802.11b Mode)/2462 | Polarization : | Vertical |

| Frequency (MHz) | Meter Reading (dBμV) | Factor (dB) | Emission Level (dBμV/m) | Limits (dBμV/m) | Margin (dB) | Detector Type |
|-----------------|----------------------|-------------|-------------------------|-----------------|-------------|---------------|
| 4924.118 | 51.86 | 10.39 | 62.25 | 74 | -11.75 | peak |
| 4924.118 | 31.99 | 10.39 | 42.38 | 54 | -11.62 | AVG |
| 7386.138 | 42.8 | 12.68 | 55.48 | 74 | -18.52 | peak |
| 7386.138 | 28.05 | 12.68 | 40.73 | 54 | -13.27 | AVG |
| | | | | | | |
| | | | | | | |
| | | | | | | |
| | | | | | | |

Remark:
Factor = Antenna Factor + Cable Loss – Pre-amplifier.

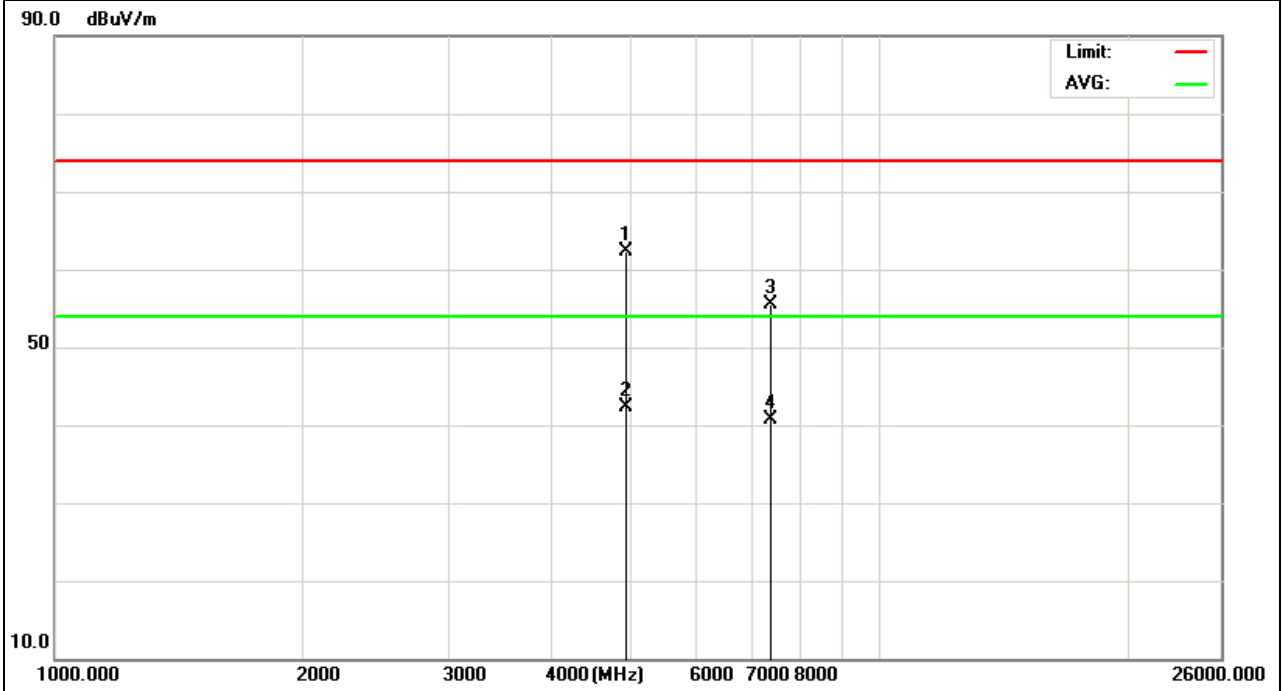

| | | | |
|---------------|-------------------------|---------------------|------------|
| EUT : | CDT-XX5370-00~09 | Model Name : | B0-9(5370) |
| Temperature : | 20 °C | Relative Humidity : | 48% |
| Pressure : | 1010 hPa | Test Voltage : | DC 5.0V |
| Test Mode : | CH1 (802.11g Mode)/2412 | Polarization : | Horizontal |

| Frequency (MHz) | Meter Reading (dBμV) | Factor (dB) | Emission Level (dBμV/m) | Limits (dBμV/m) | Margin (dB) | Detector Type |
|-----------------|----------------------|-------------|-------------------------|-----------------|-------------|---------------|
| 4824.166 | 46.97 | 10.44 | 57.41 | 74 | -16.59 | peak |
| 4824.166 | 31.15 | 10.44 | 41.59 | 54 | -12.41 | AVG |
| 7236.22 | 40.89 | 12.39 | 53.28 | 74 | -20.72 | peak |
| 7236.22 | 26.11 | 12.39 | 38.5 | 54 | -15.5 | AVG |
| | | | | | | |
| | | | | | | |
| | | | | | | |
| | | | | | | |

Remark:
Factor = Antenna Factor + Cable Loss – Pre-amplifier.

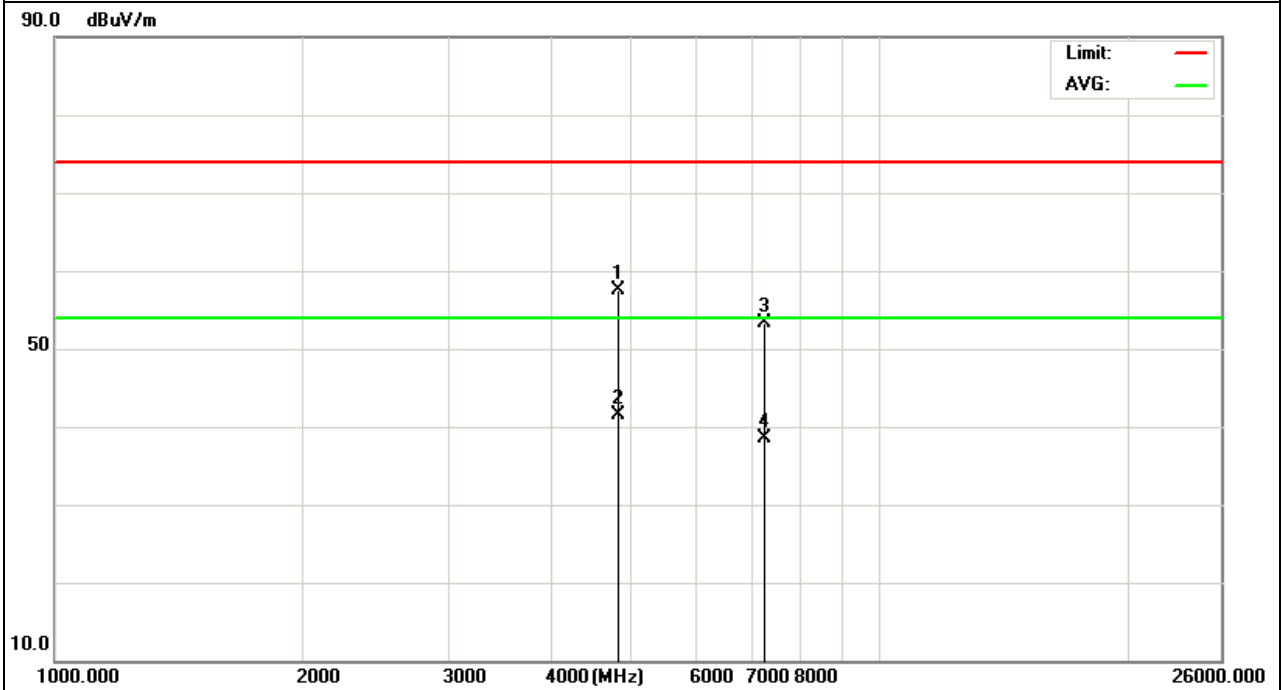

| | | | |
|---------------|-------------------------|---------------------|------------|
| EUT : | CDT-XX5370-00~09 | Model Name : | B0-9(5370) |
| Temperature : | 20 °C | Relative Humidity : | 48% |
| Pressure : | 1010 hPa | Test Voltage : | DC 5.0V |
| Test Mode : | CH1 (802.11g Mode)/2412 | Polarization : | Vertical |

| Frequency (MHz) | Meter Reading (dBμV) | Factor (dB) | Emission Level (dBμV/m) | Limits (dBμV/m) | Margin (dB) | Detector Type |
|-----------------|----------------------|-------------|-------------------------|-----------------|-------------|---------------|
| 4824.151 | 48.01 | 10.44 | 58.45 | 74 | -15.55 | peak |
| 4824.151 | 32.25 | 10.44 | 42.69 | 54 | -11.31 | AVG |
| 7236.138 | 42.16 | 12.39 | 54.55 | 74 | -19.45 | peak |
| 7236.138 | 26.24 | 12.39 | 38.63 | 54 | -15.37 | AVG |
| | | | | | | |
| | | | | | | |
| | | | | | | |
| | | | | | | |

Remark:
Factor = Antenna Factor + Cable Loss – Pre-amplifier.

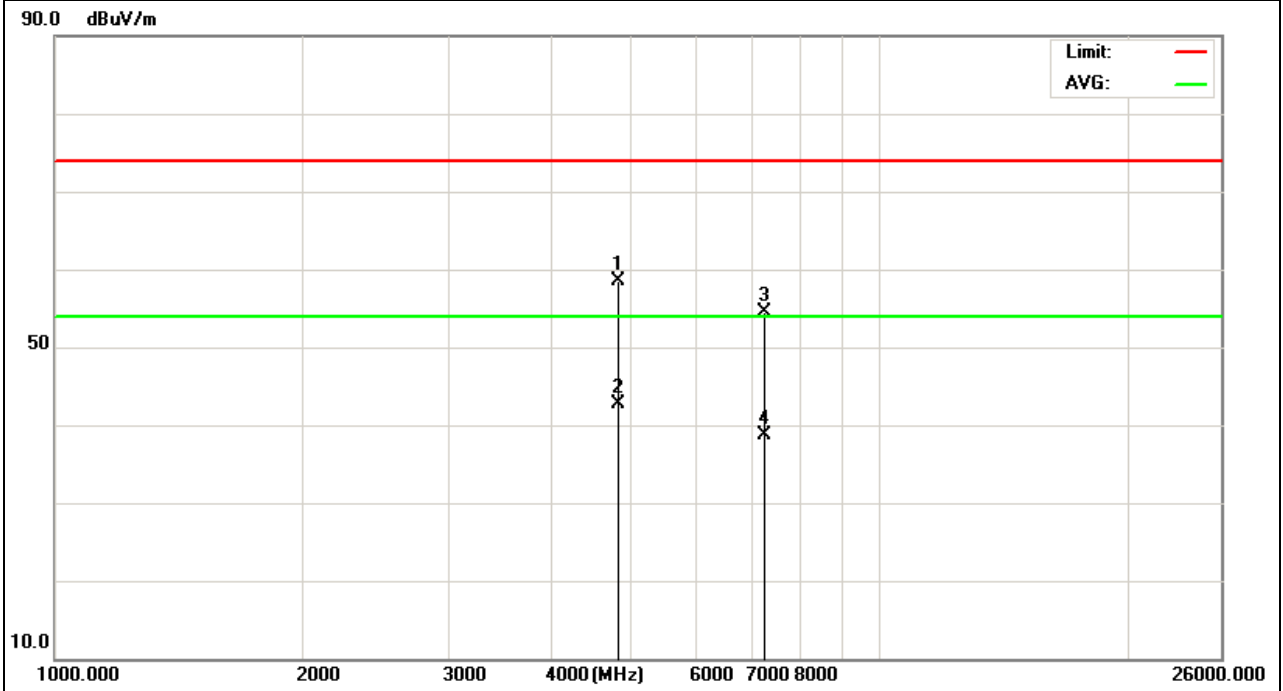

| | | | |
|---------------|-------------------------|---------------------|------------|
| EUT : | CDT-XX5370-00~09 | Model Name : | B0-9(5370) |
| Temperature : | 20 °C | Relative Humidity : | 48% |
| Pressure : | 1010 hPa | Test Voltage : | DC 5.0V |
| Test Mode : | CH6 (802.11g Mode)/2437 | Polarization : | Horizontal |

| Frequency (MHz) | Meter Reading (dBμV) | Factor (dB) | Emission Level (dBμV/m) | Limits (dBμV/m) | Margin (dB) | Detector Type |
|-----------------|----------------------|-------------|-------------------------|-----------------|-------------|---------------|
| 4874.136 | 48.49 | 10.4 | 58.89 | 74 | -15.11 | peak |
| 4874.136 | 31.48 | 10.4 | 41.88 | 54 | -12.12 | AVG |
| 7311.166 | 38.4 | 12.75 | 51.15 | 74 | -22.85 | peak |
| 7311.166 | 26.5 | 12.75 | 39.25 | 54 | -14.75 | AVG |
| | | | | | | |
| | | | | | | |

Remark:
Factor = Antenna Factor + Cable Loss – Pre-amplifier.

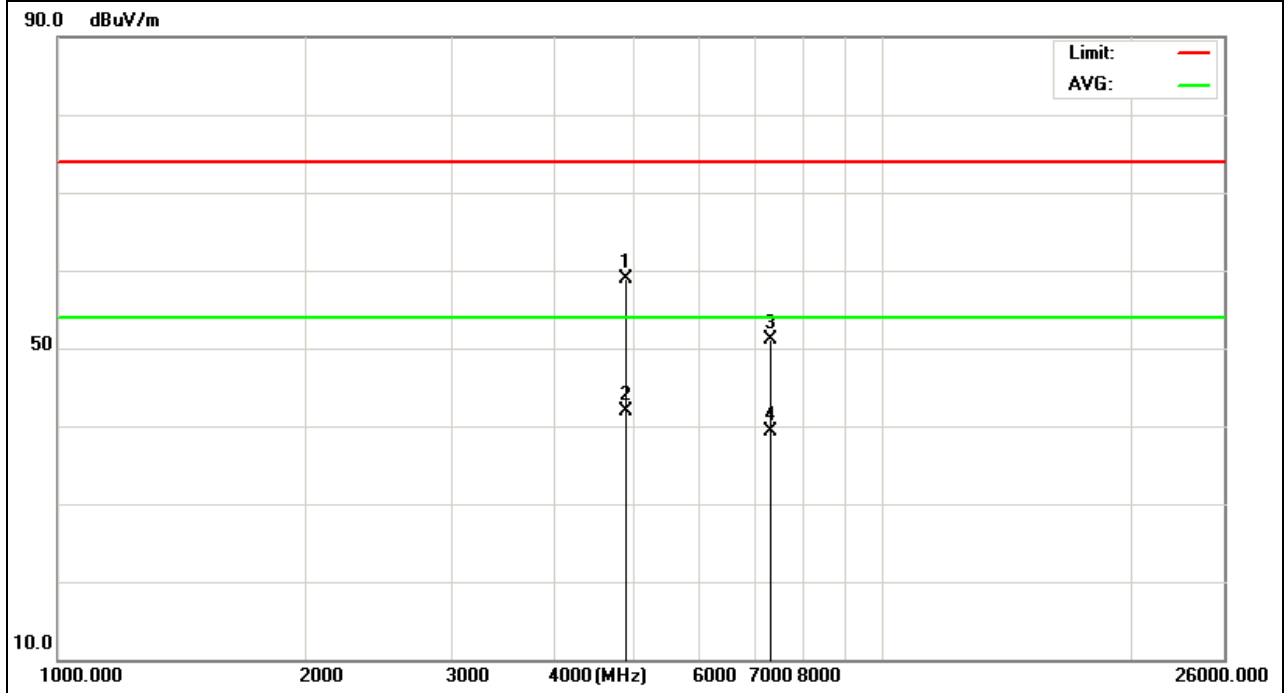

| | | | |
|---------------|-------------------------|---------------------|------------|
| EUT : | CDT-XX5370-00~09 | Model Name : | B0-9(5370) |
| Temperature : | 20 °C | Relative Humidity : | 48% |
| Pressure : | 1010 hPa | Test Voltage : | DC 5.0V |
| Test Mode : | CH6 (802.11g Mode)/2437 | Polarization : | Vertical |

| Frequency (MHz) | Meter Reading (dBμV) | Factor (dB) | Emission Level (dBμV/m) | Limits (dBμV/m) | Margin (dB) | Detector Type |
|-----------------|----------------------|-------------|-------------------------|-----------------|-------------|---------------|
| 4874.154 | 48.38 | 10.4 | 58.78 | 74 | -15.22 | peak |
| 4874.154 | 32.25 | 10.4 | 42.65 | 54 | -11.35 | AVG |
| 7311.133 | 42.67 | 12.75 | 55.42 | 74 | -18.58 | peak |
| 7311.133 | 27.89 | 12.75 | 40.64 | 54 | -13.36 | AVG |
| | | | | | | |
| | | | | | | |

Remark:
Factor = Antenna Factor + Cable Loss – Pre-amplifier.

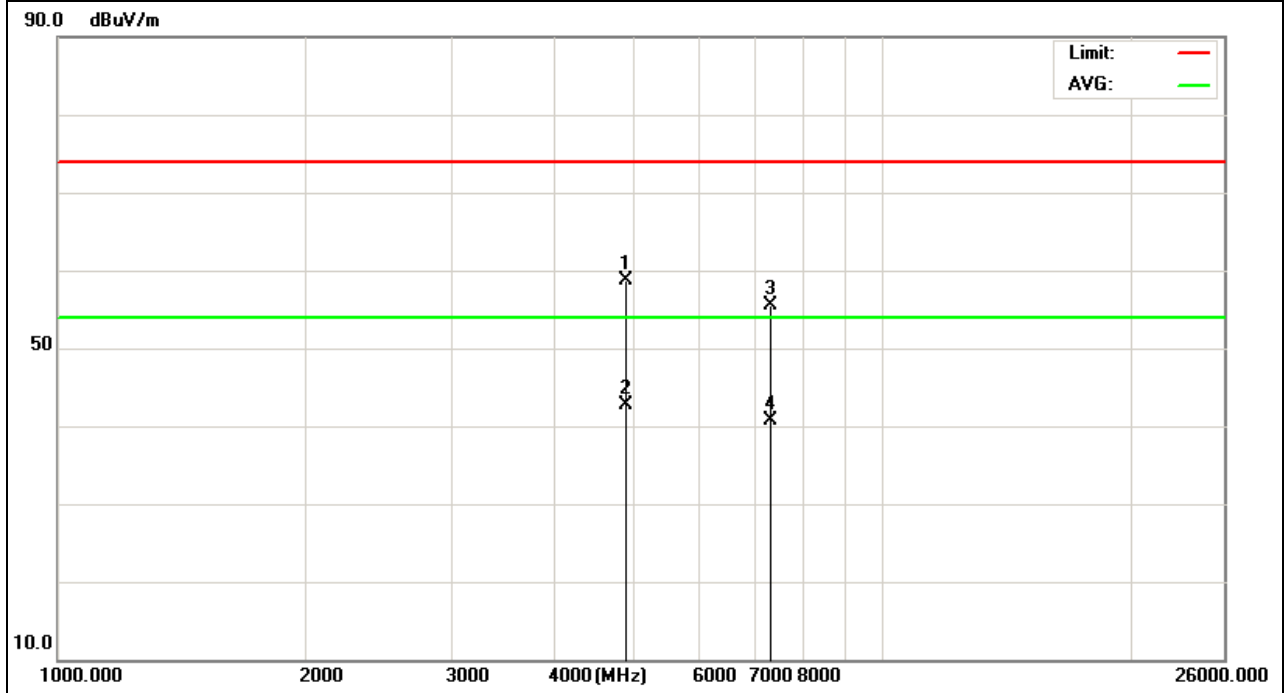

| | | | |
|---------------|--------------------------|---------------------|------------|
| EUT : | CDT-XX5370-00~09 | Model Name : | B0-9(5370) |
| Temperature : | 20 °C | Relative Humidity : | 48% |
| Pressure : | 1010 hPa | Test Voltage : | DC 5.0V |
| Test Mode : | CH11 (802.11g Mode)/2462 | Polarization : | Horizontal |

| Frequency (MHz) | Meter Reading (dBμV) | Factor (dB) | Emission Level (dBμV/m) | Limits (dBμV/m) | Margin (dB) | Detector Type |
|-----------------|----------------------|-------------|-------------------------|-----------------|-------------|---------------|
| 4924.134 | 48.48 | 10.39 | 58.87 | 74 | -15.13 | peak |
| 4924.134 | 33.28 | 10.39 | 43.67 | 54 | -10.33 | AVG |
| 7386.145 | 42.88 | 12.68 | 55.56 | 74 | -18.44 | peak |
| 7386.145 | 27.88 | 12.68 | 40.56 | 54 | -13.44 | AVG |
| | | | | | | |
| | | | | | | |
| | | | | | | |
| | | | | | | |

Remark:
Factor = Antenna Factor + Cable Loss – Pre-amplifier.

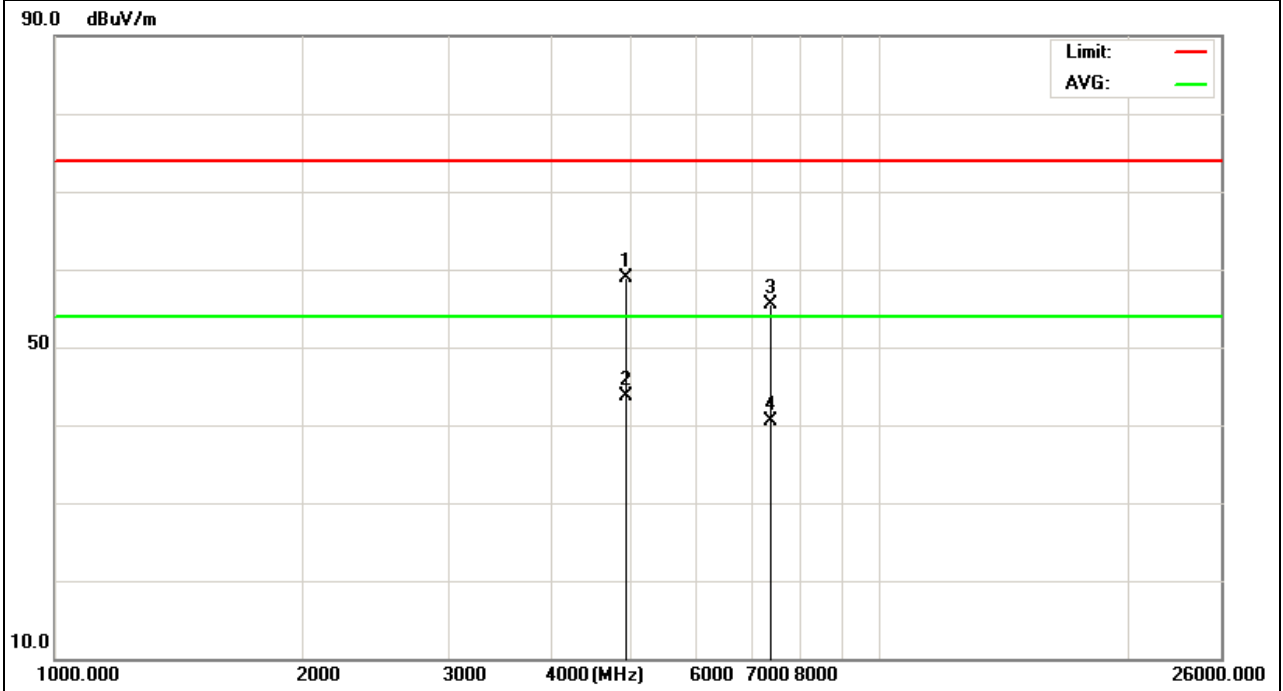

| | | | |
|---------------|-------------------------|---------------------|------------|
| EUT : | CDT-XX5370-00~09 | Model Name : | B0-9(5370) |
| Temperature : | 20 °C | Relative Humidity : | 48% |
| Pressure : | 1010 hPa | Test Voltage : | DC 5.0V |
| Test Mode : | CH11(802.11g Mode)/2462 | Polarization : | Vertical |

| Frequency (MHz) | Meter Reading (dBμV) | Factor (dB) | Emission Level (dBμV/m) | Limits (dBμV/m) | Margin (dB) | Detector Type |
|-----------------|----------------------|-------------|-------------------------|-----------------|-------------|---------------|
| 4924.144 | 47.17 | 10.39 | 57.56 | 74 | -16.44 | peak |
| 4924.144 | 32.04 | 10.39 | 42.43 | 54 | -11.57 | AVG |
| 7386.125 | 39.89 | 12.68 | 52.57 | 74 | -21.43 | peak |
| 7386.125 | 27.74 | 12.68 | 40.42 | 54 | -13.58 | AVG |
| | | | | | | |
| | | | | | | |
| | | | | | | |
| | | | | | | |

Remark:
Factor = Antenna Factor + Cable Loss – Pre-amplifier.

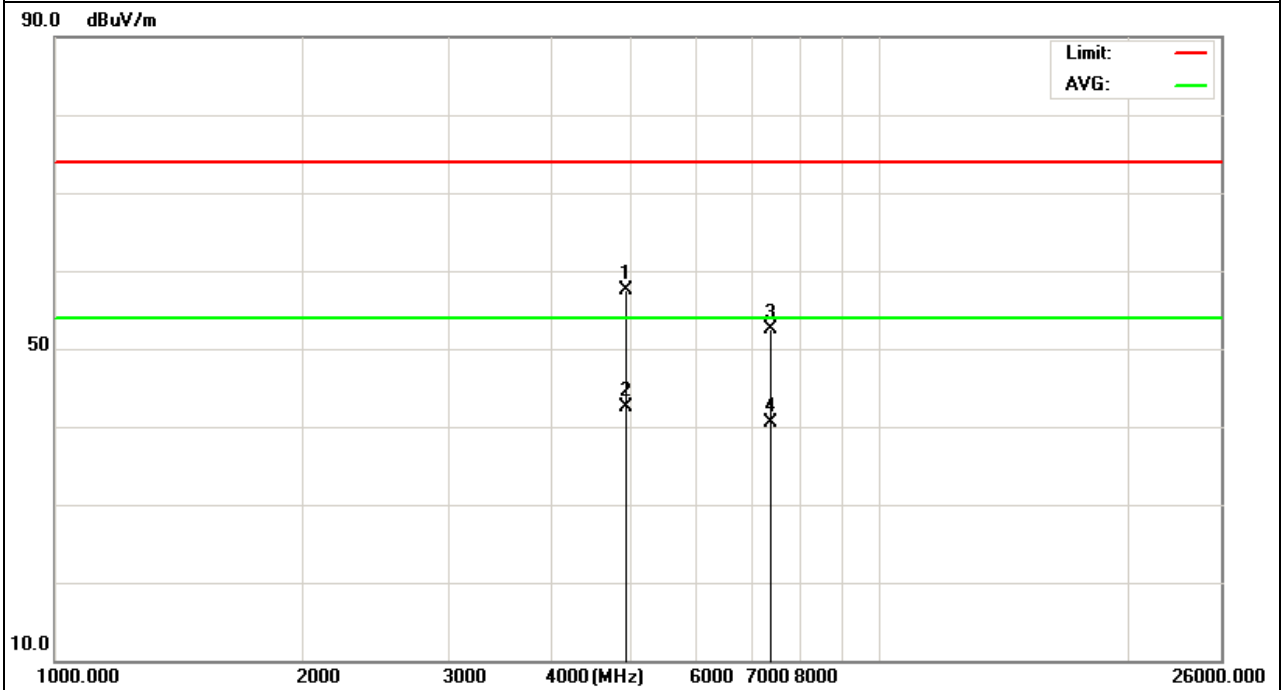

| | | | |
|---------------|-------------------------|---------------------|------------|
| EUT : | CDT-XX5370-00~09 | Model Name : | B0-9(5370) |
| Temperature : | 20 °C | Relative Humidity : | 48% |
| Pressure : | 1010 hPa | Test Voltage : | DC 5.0V |
| Test Mode : | CH1(802.11n Mode)/20MHz | Polarization : | Horizontal |

| Frequency (MHz) | Meter Reading (dBμV) | Factor (dB) | Emission Level (dBμV/m) | Limits (dBμV/m) | Margin (dB) | Detector Type |
|-----------------|----------------------|-------------|-------------------------|-----------------|-------------|---------------|
| 4824.136 | 49.01 | 10.44 | 59.45 | 74 | -14.55 | peak |
| 4824.136 | 32.94 | 10.44 | 43.38 | 54 | -10.62 | AVG |
| 7236.118 | 41.24 | 12.39 | 53.63 | 74 | -20.37 | peak |
| 7236.118 | 28.02 | 12.39 | 40.41 | 54 | -13.59 | AVG |
| | | | | | | |
| | | | | | | |

Remark:
 Factor = Antenna Factor + Cable Loss – Pre-amplifier.

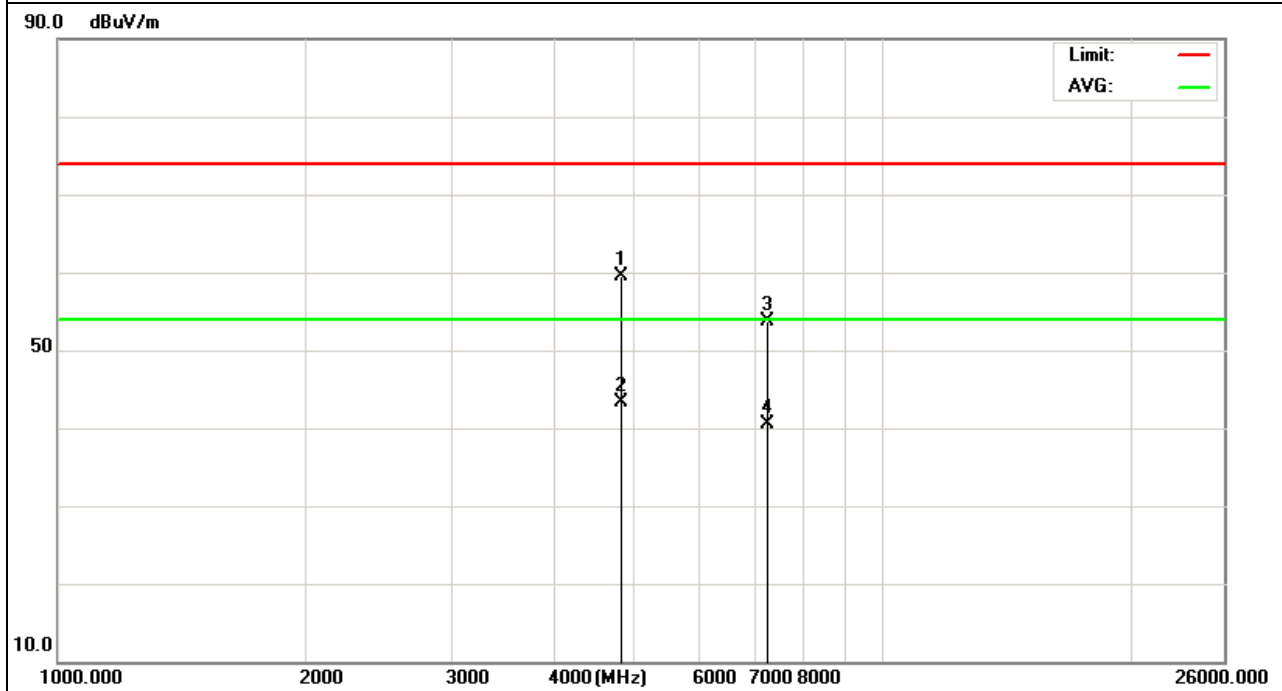

| | | | |
|---------------|-------------------------|---------------------|------------|
| EUT : | CDT-XX5370-00~09 | Model Name : | B0-9(5370) |
| Temperature : | 20 °C | Relative Humidity : | 48% |
| Pressure : | 1010 hPa | Test Voltage : | DC 5.0V |
| Test Mode : | CH1(802.11n Mode)/20MHz | Polarization : | Vertical |

| Frequency (MHz) | Meter Reading (dBμV) | Factor (dB) | Emission Level (dBμV/m) | Limits (dBμV/m) | Margin (dB) | Detector Type |
|--------------------|-------------------------|----------------|----------------------------|--------------------|----------------|---------------|
| 4824.137 | 48.18 | 10.44 | 58.62 | 74 | -15.38 | peak |
| 4824.137 | 32.45 | 10.44 | 42.89 | 54 | -11.11 | AVG |
| 7236.141 | 42.14 | 12.39 | 54.53 | 74 | -19.47 | peak |
| 7236.141 | 27.33 | 12.39 | 39.72 | 54 | -14.28 | AVG |
| | | | | | | |
| | | | | | | |

Remark:
Factor = Antenna Factor + Cable Loss – Pre-amplifier.

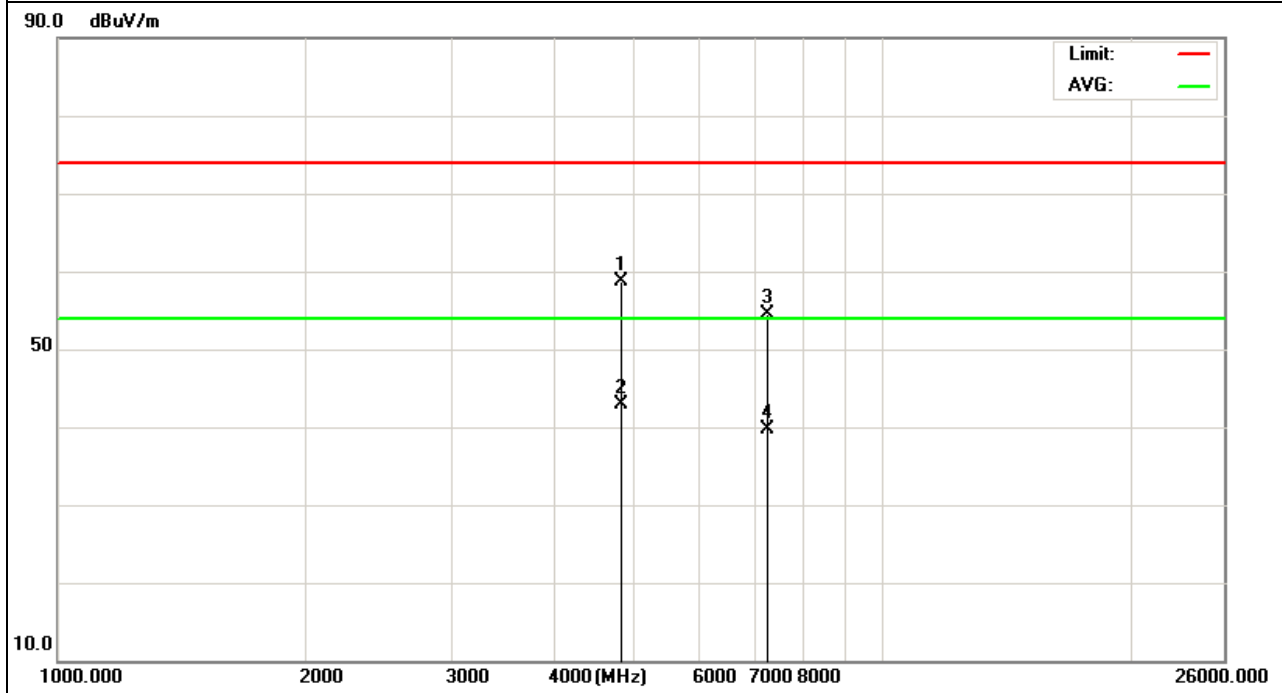

| | | | |
|---------------|-------------------------|---------------------|------------|
| EUT : | CDT-XX5370-00~09 | Model Name : | B0-9(5370) |
| Temperature : | 20 °C | Relative Humidity : | 48% |
| Pressure : | 1010 hPa | Test Voltage : | DC 5.0V |
| Test Mode : | CH6(802.11n Mode)/20MHz | Polarization : | Horizontal |

| Frequency (MHz) | Meter Reading (dBμV) | Factor (dB) | Emission Level (dBμV/m) | Limits (dBμV/m) | Margin (dB) | Detector Type |
|-----------------|----------------------|-------------|-------------------------|-----------------|-------------|---------------|
| 4874.156 | 47.98 | 10.4 | 58.38 | 74 | -15.62 | peak |
| 4874.156 | 30.81 | 10.4 | 41.21 | 54 | -12.79 | AVG |
| 7311.124 | 41.64 | 12.75 | 54.39 | 74 | -19.61 | peak |
| 7311.124 | 26.45 | 12.75 | 39.2 | 54 | -14.8 | AVG |
| | | | | | | |
| | | | | | | |

Remark:
Factor = Antenna Factor + Cable Loss – Pre-amplifier.

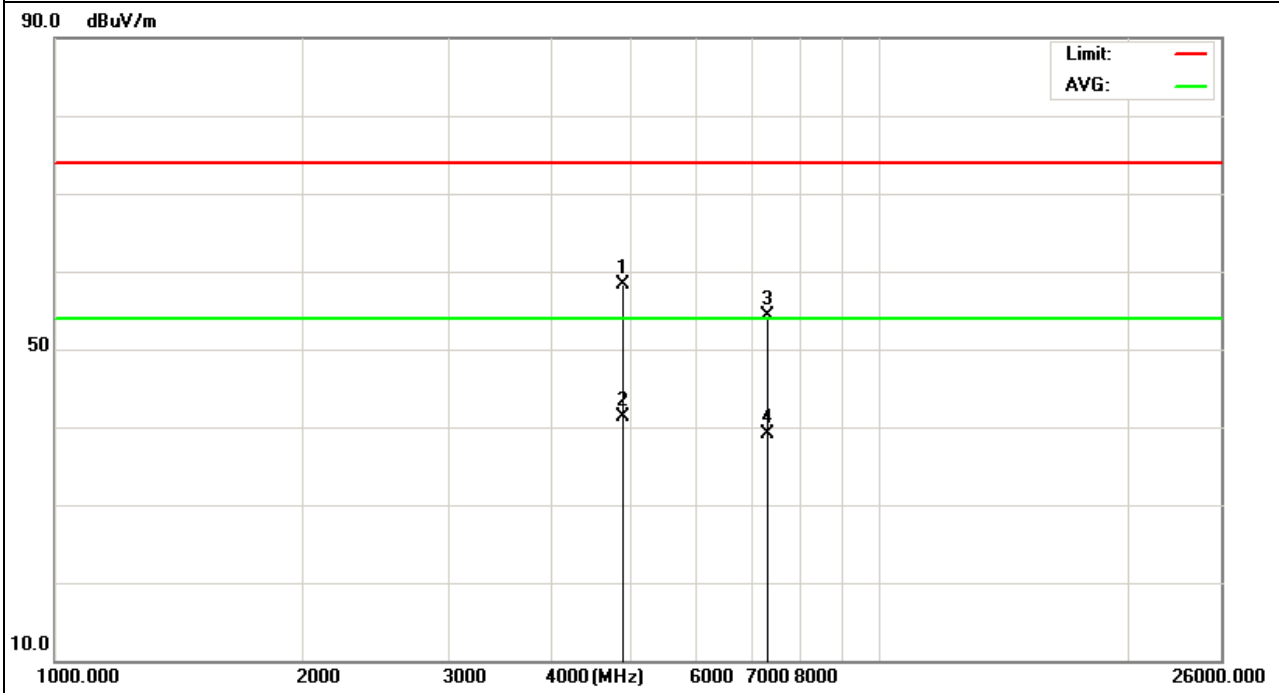

| | | | |
|---------------|-------------------------|---------------------|------------|
| EUT : | CDT-XX5370-00~09 | Model Name : | B0-9(5370) |
| Temperature : | 20 °C | Relative Humidity : | 48% |
| Pressure : | 1010 hPa | Test Voltage : | DC 5.0V |
| Test Mode : | CH6(802.11n Mode)/20MHz | Polarization : | Vertical |

| Frequency (MHz) | Meter Reading (dBμV) | Factor (dB) | Emission Level (dBμV/m) | Limits (dBμV/m) | Margin (dB) | Detector Type |
|-----------------|----------------------|-------------|-------------------------|-----------------|-------------|---------------|
| 4874.157 | 47.99 | 10.4 | 58.39 | 74 | -15.61 | peak |
| 4874.157 | 31.18 | 10.4 | 41.58 | 54 | -12.42 | AVG |
| 7311.165 | 41.62 | 12.75 | 54.37 | 74 | -19.63 | peak |
| 7311.165 | 26.9 | 12.75 | 39.65 | 54 | -14.35 | AVG |
| | | | | | | |
| | | | | | | |

Remark:

Factor = Antenna Factor + Cable Loss – Pre-amplifier.

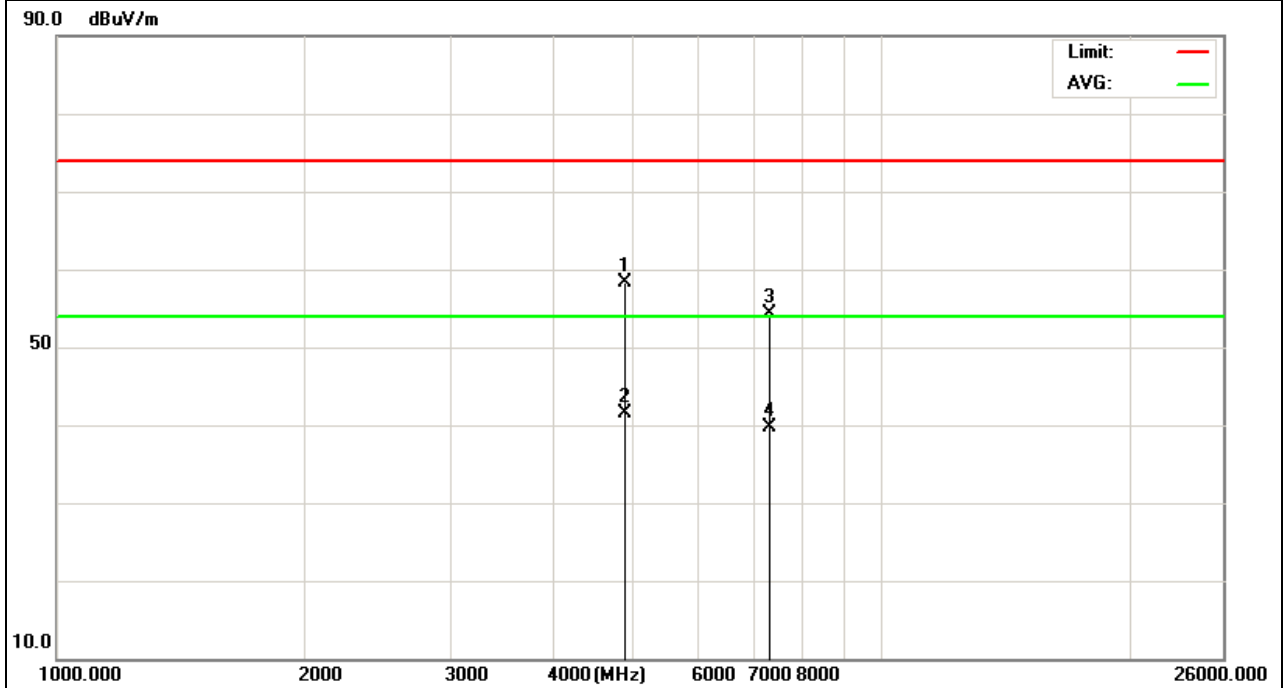

| | | | |
|---------------|--------------------------|---------------------|------------|
| EUT : | CDT-XX5370-00~09 | Model Name : | B0-9(5370) |
| Temperature : | 20 °C | Relative Humidity : | 48% |
| Pressure : | 1010 hPa | Test Voltage : | DC 5.0V |
| Test Mode : | CH11(802.11n Mode)/20MHz | Polarization : | Horizontal |

| Frequency (MHz) | Meter Reading (dBμV) | Factor (dB) | Emission Level (dBμV/m) | Limits (dBμV/m) | Margin (dB) | Detector Type |
|-----------------|----------------------|-------------|-------------------------|-----------------|-------------|---------------|
| 4924.136 | 49.16 | 10.39 | 59.55 | 74 | -14.45 | peak |
| 4924.136 | 31.27 | 10.39 | 41.66 | 54 | -12.34 | AVG |
| 7386.179 | 41.8 | 12.68 | 54.48 | 74 | -19.52 | peak |
| 7386.179 | 26.55 | 12.68 | 39.23 | 54 | -14.77 | AVG |
| | | | | | | |
| | | | | | | |

Remark:
 Factor = Antenna Factor + Cable Loss – Pre-amplifier.

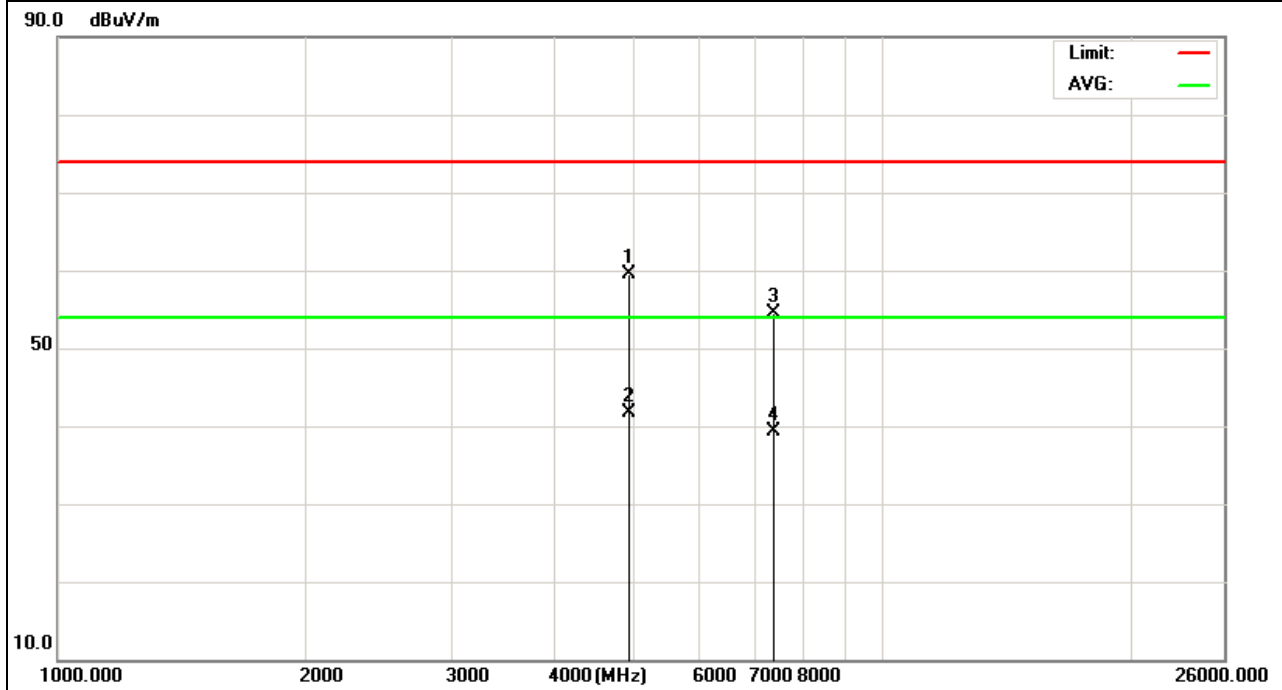

| | | | |
|---------------|--------------------------|---------------------|------------|
| EUT : | CDT-XX5370-00~09 | Model Name : | B0-9(5370) |
| Temperature : | 20 °C | Relative Humidity : | 48% |
| Pressure : | 1010 hPa | Test Voltage : | DC 5.0V |
| Test Mode : | CH11(802.11n Mode)/20MHz | Polarization : | Vertical |

| Frequency (MHz) | Meter Reading (dBμV) | Factor (dB) | Emission Level (dBμV/m) | Limits (dBμV/m) | Margin (dB) | Detector Type |
|--------------------|-------------------------|----------------|----------------------------|--------------------|----------------|---------------|
| 4924.146 | 49.13 | 10.39 | 59.52 | 74 | -14.48 | peak |
| 4924.146 | 32.26 | 10.39 | 42.65 | 54 | -11.35 | AVG |
| 7386.163 | 43.61 | 12.68 | 56.29 | 74 | -17.71 | peak |
| 7386.163 | 27.89 | 12.68 | 40.57 | 54 | -13.43 | AVG |
| | | | | | | |
| | | | | | | |

Remark:
Factor = Antenna Factor + Cable Loss – Pre-amplifier.

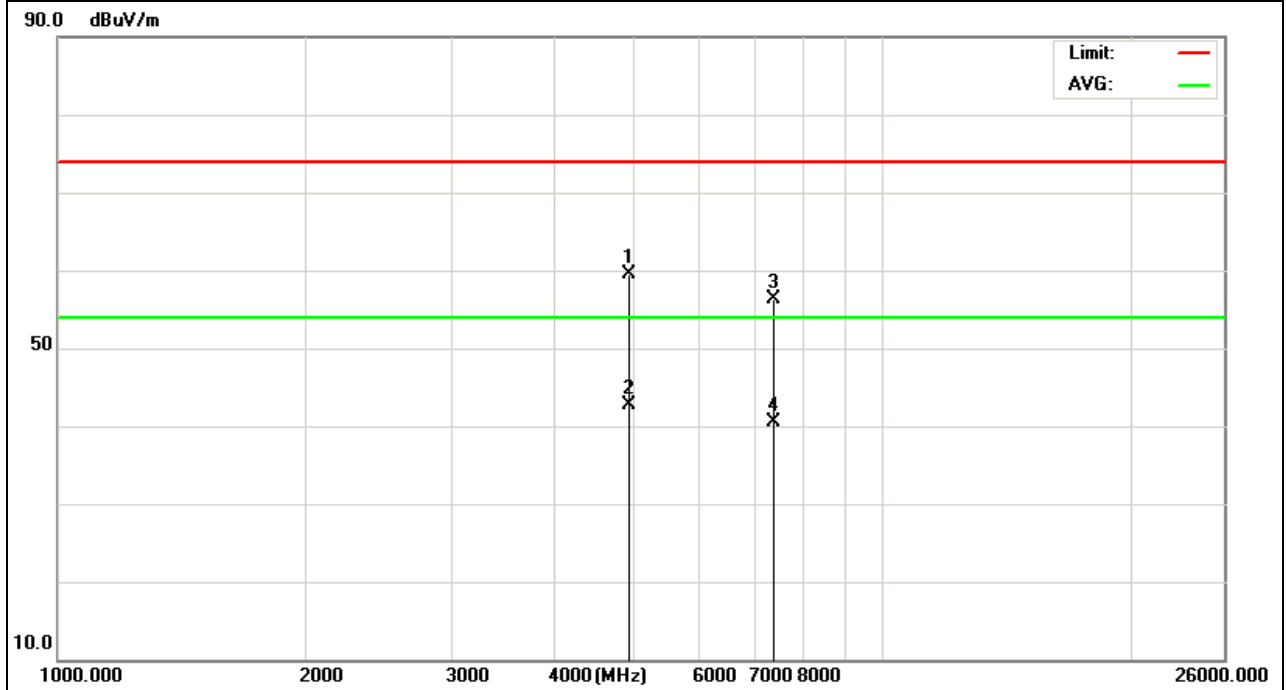

| | | | |
|---------------|-------------------------|---------------------|------------|
| EUT : | CDT-XX5370-00~09 | Model Name : | B0-9(5370) |
| Temperature : | 20 °C | Relative Humidity : | 48% |
| Pressure : | 1010 hPa | Test Voltage : | DC 5.0V |
| Test Mode : | CH3(802.11n Mode)/40MHz | Polarization : | Horizontal |

| Frequency (MHz) | Meter Reading (dBμV) | Factor (dB) | Emission Level (dBμV/m) | Limits (dBμV/m) | Margin (dB) | Detector Type |
|-----------------|----------------------|-------------|-------------------------|-----------------|-------------|---------------|
| 4844.155 | 46.91 | 10.5 | 57.41 | 74 | -16.59 | peak |
| 4844.155 | 31.97 | 10.5 | 42.47 | 54 | -11.53 | AVG |
| 7266.318 | 40.83 | 12.5 | 53.33 | 74 | -20.67 | peak |
| 7266.318 | 28.17 | 12.5 | 40.67 | 54 | -13.33 | AVG |
| | | | | | | |
| | | | | | | |

Remark:
 Factor = Antenna Factor + Cable Loss – Pre-amplifier.

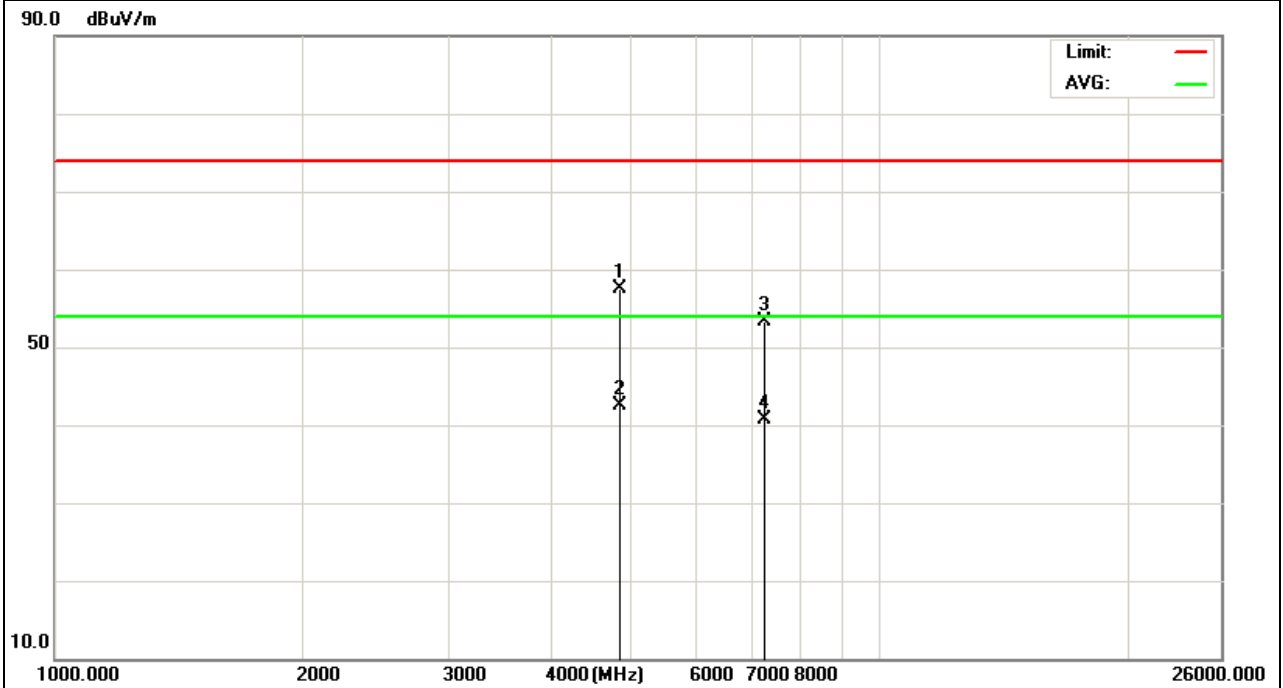

| | | | |
|---------------|-------------------------|---------------------|------------|
| EUT : | CDT-XX5370-00~09 | Model Name : | B0-9(5370) |
| Temperature : | 20 °C | Relative Humidity : | 48% |
| Pressure : | 1010 hPa | Test Voltage : | DC 5.0V |
| Test Mode : | CH3(802.11n Mode)/40MHz | Polarization : | Vertical |

| Frequency (MHz) | Meter Reading (dBμV) | Factor (dB) | Emission Level (dBμV/m) | Limits (dBμV/m) | Margin (dB) | Detector Type |
|-----------------|----------------------|-------------|-------------------------|-----------------|-------------|---------------|
| 4844.324 | 46.05 | 10.5 | 56.55 | 74 | -17.45 | peak |
| 4844.324 | 31.99 | 10.5 | 42.49 | 54 | -11.51 | AVG |
| 7266.257 | 40.88 | 12.5 | 53.38 | 74 | -20.62 | peak |
| 7266.257 | 27.79 | 12.5 | 40.29 | 54 | -13.71 | AVG |
| | | | | | | |
| | | | | | | |

Remark:
 Factor = Antenna Factor + Cable Loss – Pre-amplifier.

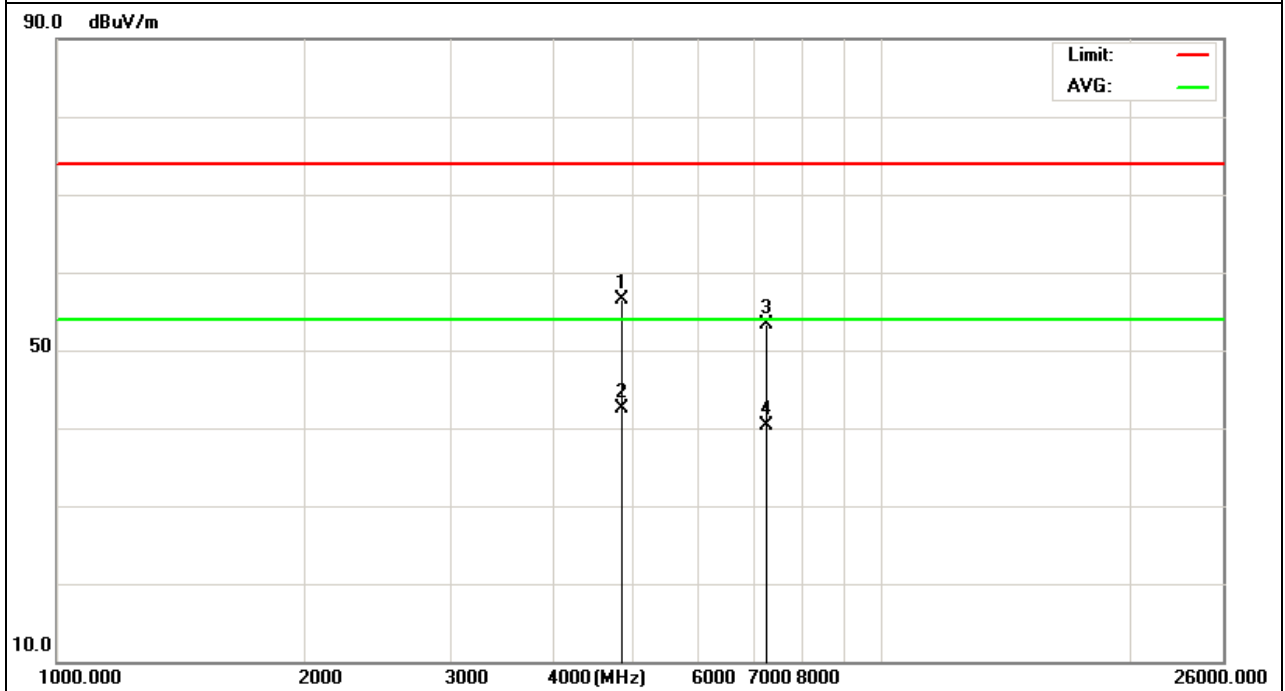

| | | | |
|---------------|-------------------------|---------------------|------------|
| EUT : | CDT-XX5370-00~09 | Model Name : | B0-9(5370) |
| Temperature : | 20 °C | Relative Humidity : | 48% |
| Pressure : | 1010 hPa | Test Voltage : | DC 5.0V |
| Test Mode : | CH6(802.11n Mode)/40MHz | Polarization : | Horizontal |

| Frequency (MHz) | Meter Reading (dBμV) | Factor (dB) | Emission Level (dBμV/m) | Limits (dBμV/m) | Margin (dB) | Detector Type |
|-----------------|----------------------|-------------|-------------------------|-----------------|-------------|---------------|
| 4874.234 | 46.93 | 10.4 | 57.33 | 74 | -16.67 | peak |
| 4874.234 | 32.18 | 10.4 | 42.58 | 54 | -11.42 | AVG |
| 7311.157 | 40.74 | 12.75 | 53.49 | 74 | -20.51 | peak |
| 7311.157 | 26.77 | 12.75 | 39.52 | 54 | -14.48 | AVG |
| | | | | | | |
| | | | | | | |

Remark:
 Factor = Antenna Factor + Cable Loss – Pre-amplifier.

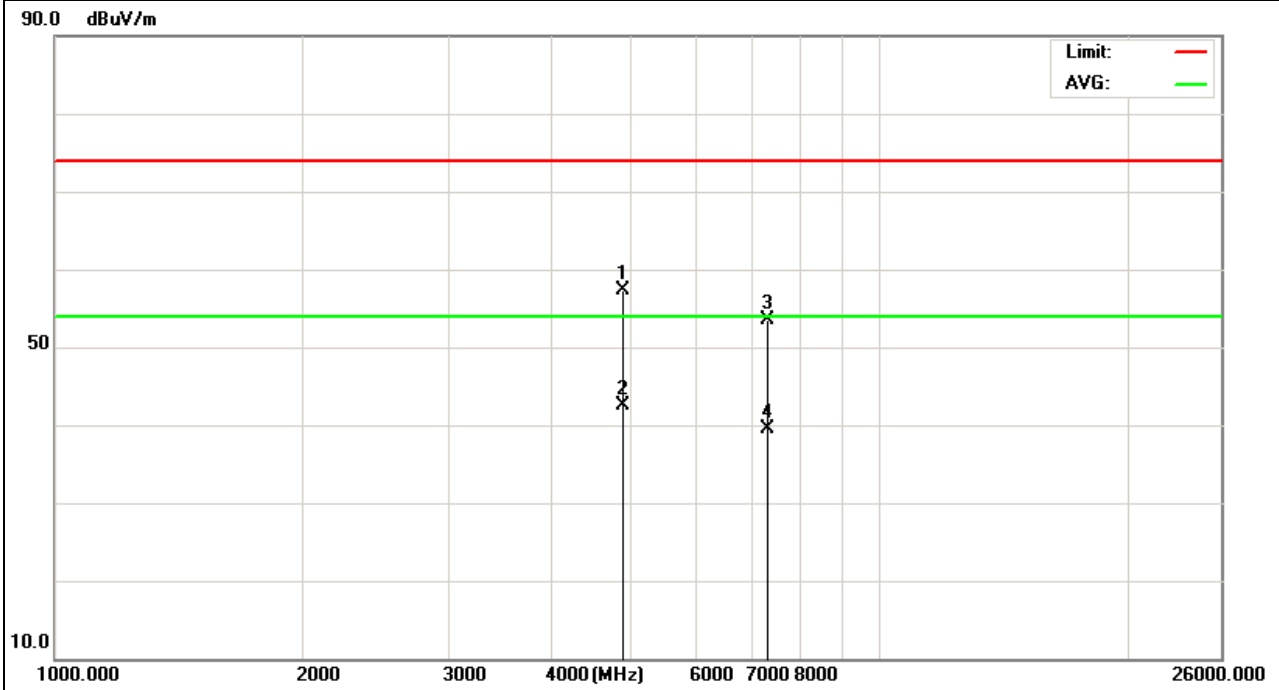

| | | | |
|---------------|-------------------------|---------------------|------------|
| EUT : | CDT-XX5370-00~09 | Model Name : | B0-9(5370) |
| Temperature : | 20 °C | Relative Humidity : | 48% |
| Pressure : | 1010 hPa | Test Voltage : | DC 5.0V |
| Test Mode : | CH6(802.11n Mode)/40MHz | Polarization : | Vertical |

| Frequency (MHz) | Meter Reading (dBμV) | Factor (dB) | Emission Level (dBμV/m) | Limits (dBμV/m) | Margin (dB) | Detector Type |
|-----------------|----------------------|-------------|-------------------------|-----------------|-------------|---------------|
| 4874.535 | 46.84 | 10.4 | 57.24 | 74 | -16.76 | peak |
| 4874.535 | 32.88 | 10.4 | 43.28 | 54 | -10.72 | AVG |
| 7311.633 | 40.86 | 12.75 | 53.61 | 74 | -20.39 | peak |
| 7311.633 | 28.09 | 12.75 | 40.84 | 54 | -13.16 | AVG |
| | | | | | | |
| | | | | | | |

Remark:
 Factor = Antenna Factor + Cable Loss – Pre-amplifier.

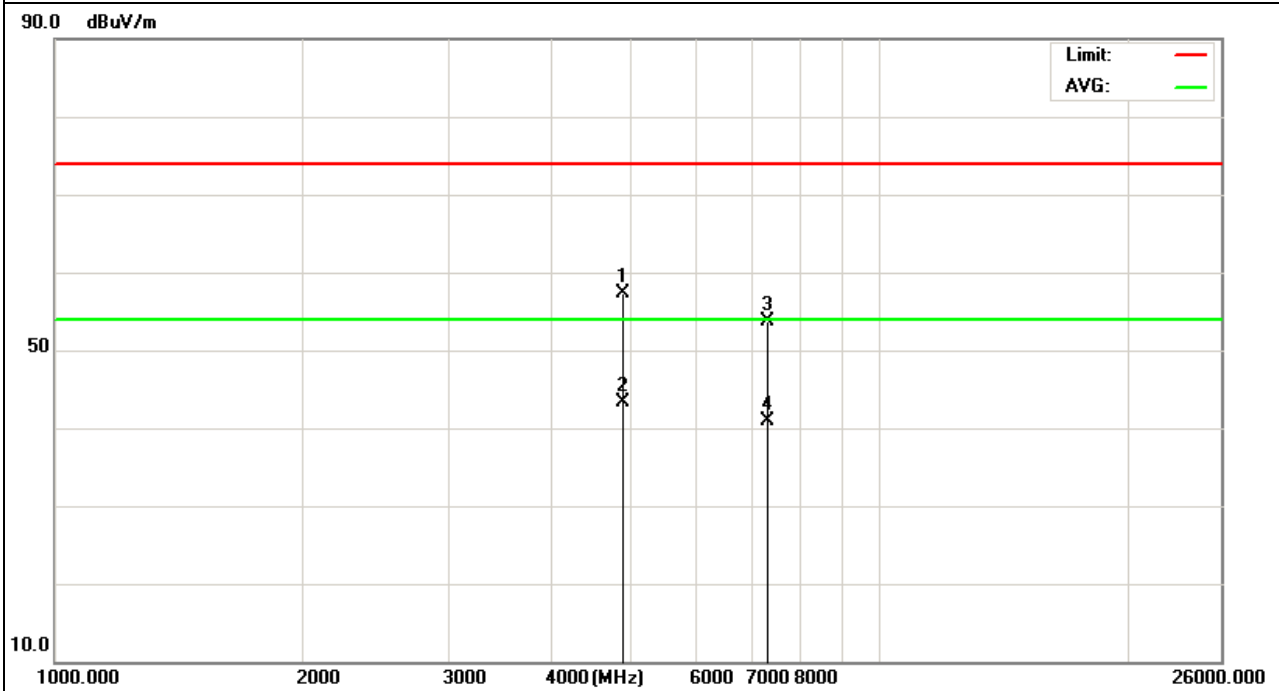

| | | | |
|---------------|-------------------------|---------------------|------------|
| EUT : | CDT-XX5370-00~09 | Model Name : | B0-9(5370) |
| Temperature : | 20 °C | Relative Humidity : | 48% |
| Pressure : | 1010 hPa | Test Voltage : | DC 5.0V |
| Test Mode : | CH9(802.11n Mode)/40MHz | Polarization : | Horizontal |

| Frequency (MHz) | Meter Reading (dBμV) | Factor (dB) | Emission Level (dBμV/m) | Limits (dBμV/m) | Margin (dB) | Detector Type |
|-----------------|----------------------|-------------|-------------------------|-----------------|-------------|---------------|
| 4904.343 | 47.27 | 10.29 | 57.56 | 74 | -16.44 | peak |
| 4904.343 | 32.2 | 10.29 | 42.49 | 54 | -11.51 | AVG |
| 7356.245 | 40.62 | 12.79 | 53.41 | 74 | -20.59 | peak |
| 7356.245 | 27.88 | 12.79 | 40.67 | 54 | -13.33 | AVG |
| | | | | | | |
| | | | | | | |

Remark:
 Factor = Antenna Factor + Cable Loss – Pre-amplifier.

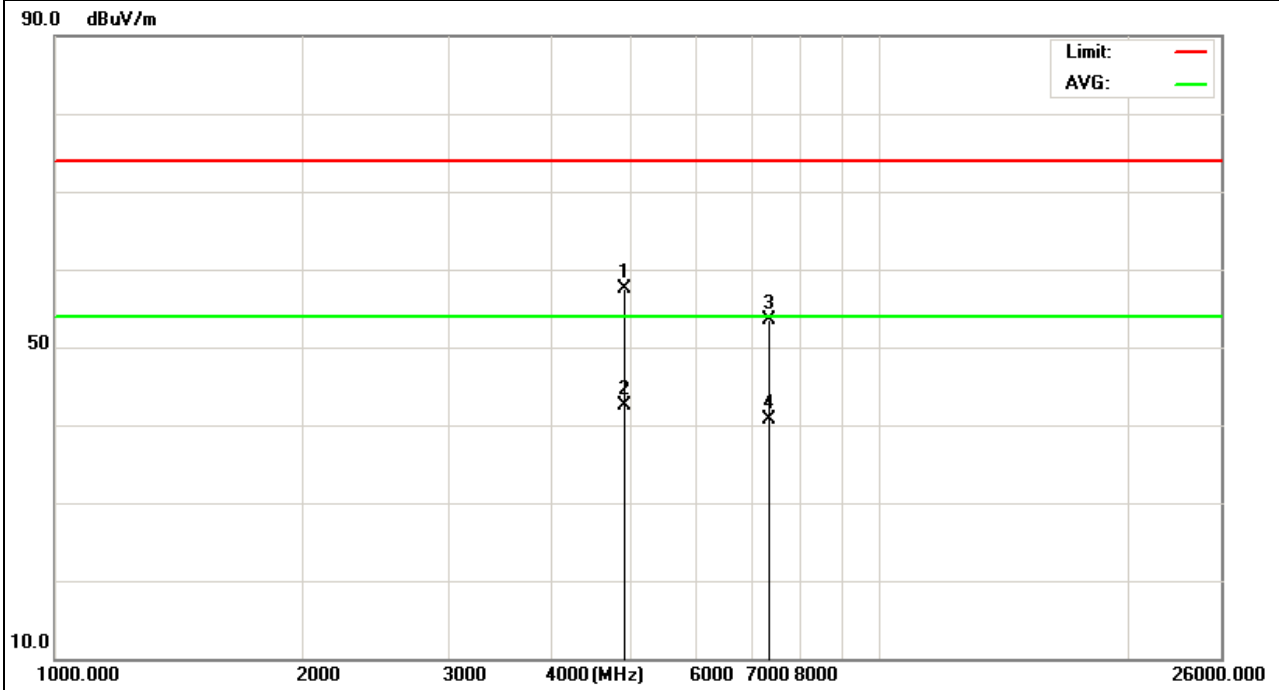

| | | | |
|---------------|-------------------------|---------------------|------------|
| EUT : | CDT-XX5370-00~09 | Model Name : | B0-9(5370) |
| Temperature : | 20 °C | Relative Humidity : | 48% |
| Pressure : | 1010 hPa | Test Voltage : | DC 5.0V |
| Test Mode : | CH9(802.11n Mode)/40MHz | Polarization : | Vertical |

| Frequency (MHz) | Meter Reading (dBμV) | Factor (dB) | Emission Level (dBμV/m) | Limits (dBμV/m) | Margin (dB) | Detector Type |
|-----------------|----------------------|-------------|-------------------------|-----------------|-------------|---------------|
| 4904.158 | 47.13 | 10.29 | 57.42 | 74 | -16.58 | peak |
| 4904.158 | 31.98 | 10.29 | 42.27 | 54 | -11.73 | AVG |
| 7356.419 | 40.96 | 12.79 | 53.75 | 74 | -20.25 | peak |
| 7356.419 | 26.84 | 12.79 | 39.63 | 54 | -14.37 | AVG |
| | | | | | | |
| | | | | | | |

Remark:
Factor = Antenna Factor + Cable Loss – Pre-amplifier.

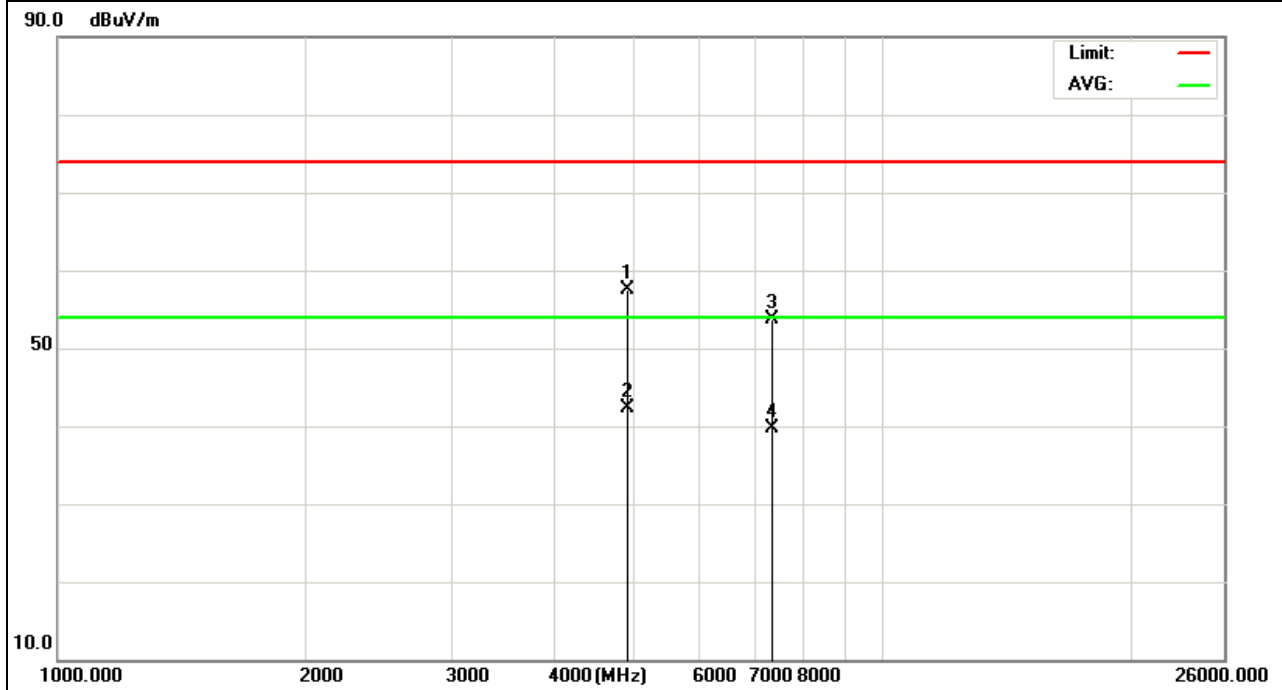

| | | | |
|---------------|-------------------|---------------------|------------|
| EUT : | CDT-XX5370-00~09 | Model Name : | B0-9(5370) |
| Temperature : | 20 °C | Relative Humidity : | 48% |
| Pressure : | 1010 hPa | Test Voltage : | DC 5.0V |
| Test Mode : | CH1(802.11b Mode) | Polarization : | Horizontal |

| Frequency (MHz) | Meter Reading (dBμV) | Factor (dB) | Emission Level (dBμV/m) | Limits (dBμV/m) | Margin (dB) | Detector Type |
|-----------------|----------------------|-------------|-------------------------|-----------------|-------------|---------------|
| 2397.1 | 72.17 | -13.02 | 59.15 | 74 | -14.85 | peak |
| 2397.1 | 56.54 | -13.02 | 43.52 | 54 | -10.48 | AVG |
| 2400 | 68.27 | -12.99 | 55.28 | 74 | -18.72 | peak |
| 2400 | 52.73 | -12.99 | 39.74 | 54 | -14.26 | AVG |
| | | | | | | |
| | | | | | | |

Remark:
 Factor = Antenna Factor + Cable Loss – Pre-amplifier.

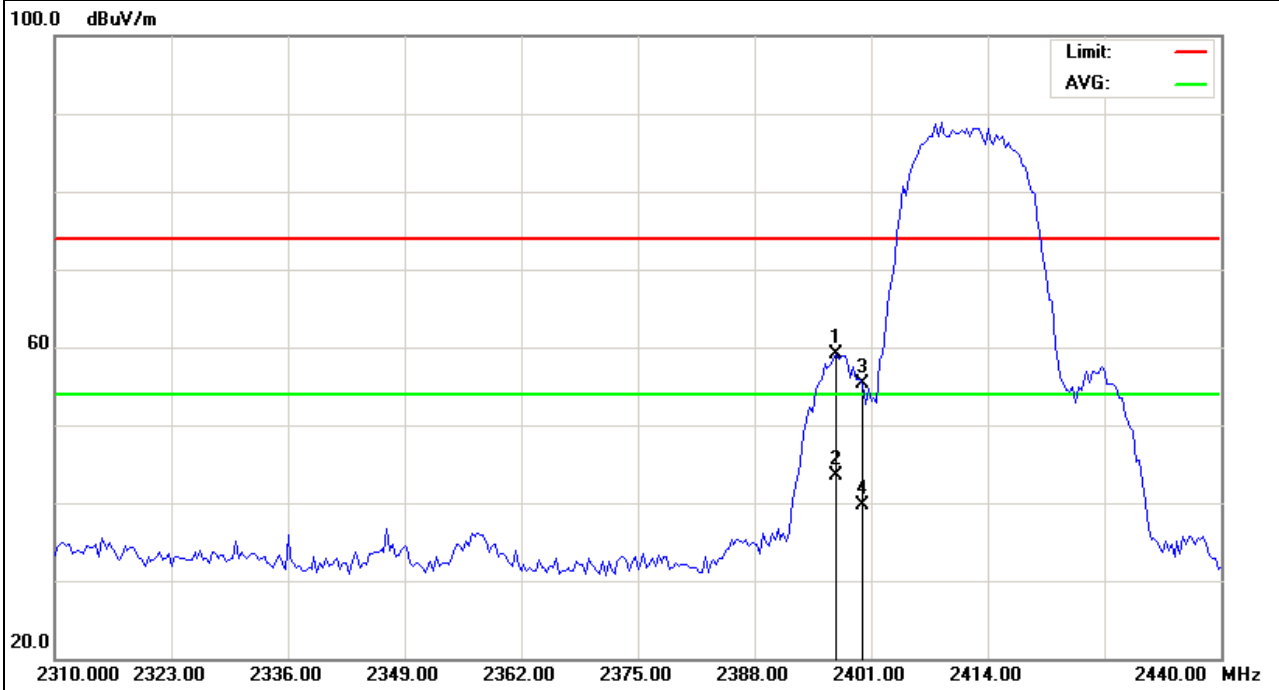

| | | | |
|---------------|-------------------|---------------------|------------|
| EUT : | CDT-XX5370-00~09 | Model Name : | B0-9(5370) |
| Temperature : | 20 °C | Relative Humidity : | 48% |
| Pressure : | 1010 hPa | Test Voltage : | DC 5.0V |
| Test Mode : | CH1(802.11b Mode) | Polarization : | Vertical |

| Frequency (MHz) | Meter Reading (dBμV) | Factor (dB) | Emission Level (dBμV/m) | Limits (dBμV/m) | Margin (dB) | Detector Type |
|-----------------|----------------------|-------------|-------------------------|-----------------|-------------|---------------|
| 2397.75 | 65.42 | -13 | 52.42 | 74 | -21.58 | peak |
| 2400 | 61.73 | -12.99 | 48.74 | 74 | -25.26 | peak |
| | | | | | | |
| | | | | | | |
| | | | | | | |
| | | | | | | |

Remark:
 Factor = Antenna Factor + Cable Loss – Pre-amplifier.

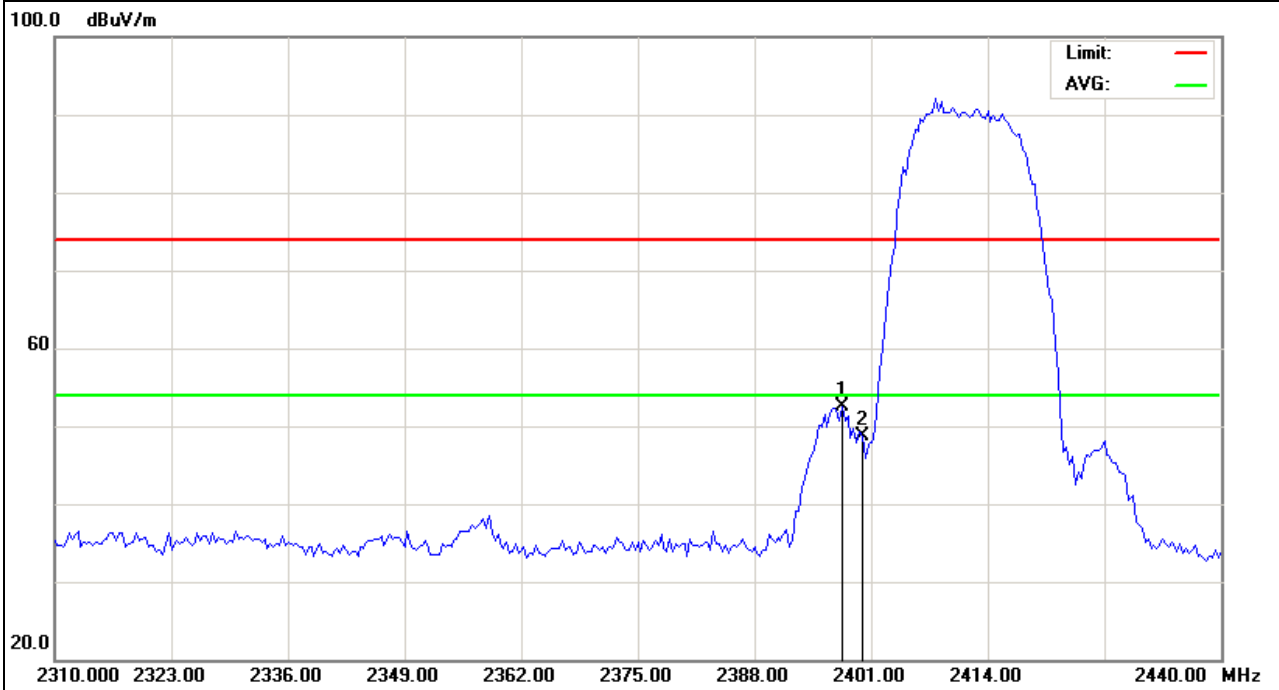

| | | | |
|---------------|--------------------|---------------------|------------|
| EUT : | CDT-XX5370-00~09 | Model Name : | B0-9(5370) |
| Temperature : | 20 °C | Relative Humidity : | 48% |
| Pressure : | 1010 hPa | Test Voltage : | DC 5.0V |
| Test Mode : | CH11(802.11b Mode) | Polarization : | Horizontal |

| Frequency (MHz) | Meter Reading (dBμV) | Factor (dB) | Emission Level (dBμV/m) | Limits (dBμV/m) | Margin (dB) | Detector Type |
|--------------------|-------------------------|----------------|----------------------------|--------------------|----------------|---------------|
| 2483.5 | 63.04 | -12.78 | 50.26 | 74 | -23.74 | peak |
| | | | | | | |
| | | | | | | |
| | | | | | | |
| | | | | | | |
| | | | | | | |

Remark:
Factor = Antenna Factor + Cable Loss – Pre-amplifier.

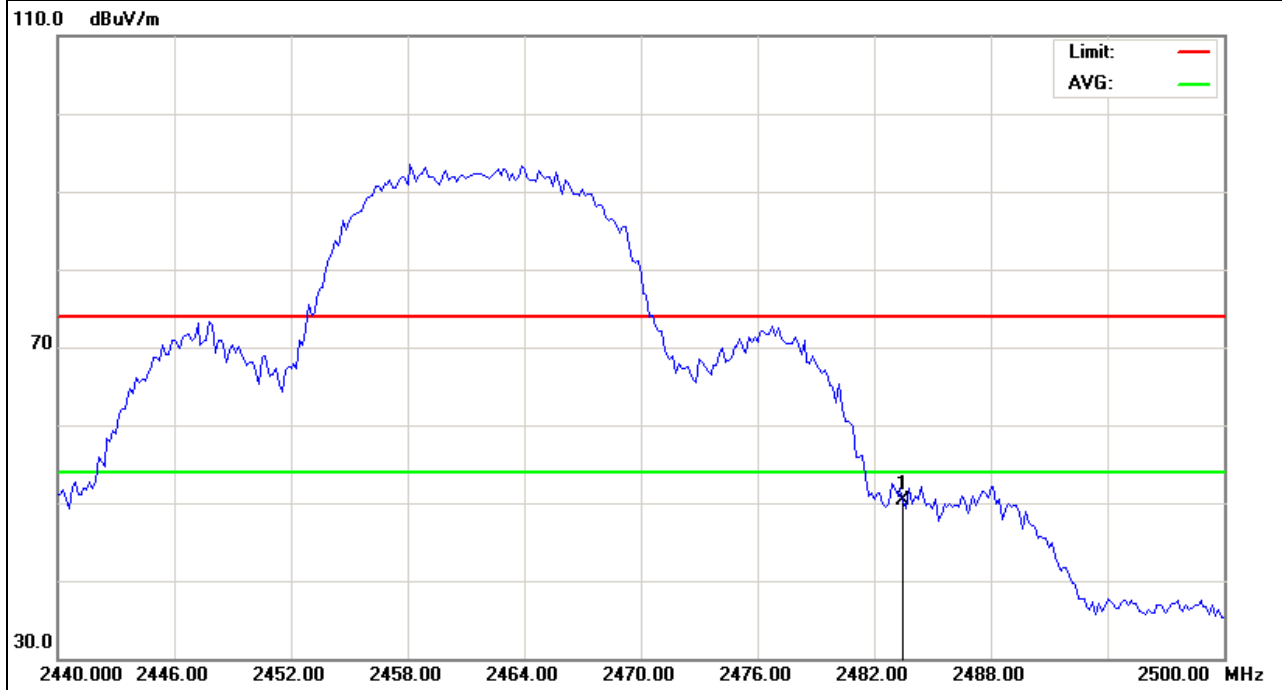

| | | | |
|---------------|--------------------|---------------------|------------|
| EUT : | CDT-XX5370-00~09 | Model Name : | B0-9(5370) |
| Temperature : | 20 °C | Relative Humidity : | 48% |
| Pressure : | 1010 hPa | Test Voltage : | DC 5.0V |
| Test Mode : | CH11(802.11b Mode) | Polarization : | Vertical |

| Frequency (MHz) | Meter Reading (dBμV) | Factor (dB) | Emission Level (dBμV/m) | Limits (dBμV/m) | Margin (dB) | Detector Type |
|--------------------|-------------------------|----------------|----------------------------|--------------------|----------------|---------------|
| 2483.5 | 65.45 | -12.78 | 52.67 | 74 | -21.33 | peak |
| | | | | | | |
| | | | | | | |
| | | | | | | |
| | | | | | | |

Remark:
Factor = Antenna Factor + Cable Loss – Pre-amplifier.

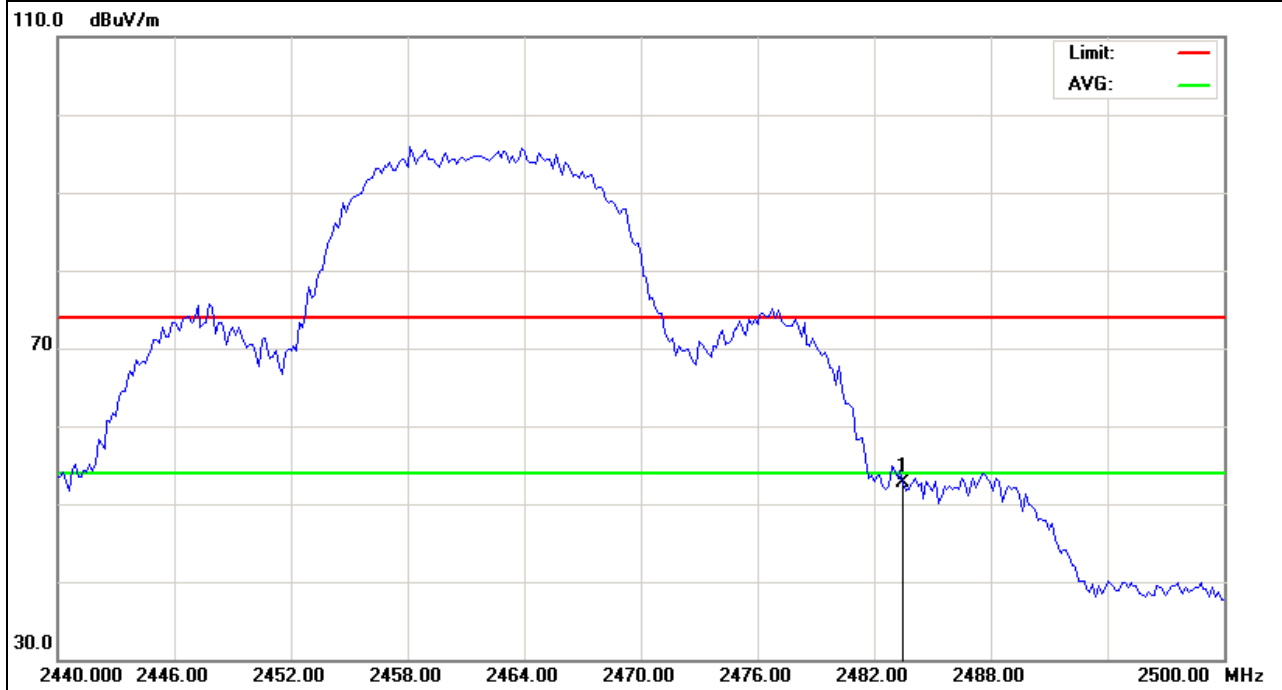

| | | | |
|---------------|-------------------|---------------------|------------|
| EUT : | CDT-XX5370-00~09 | Model Name : | B0-9(5370) |
| Temperature : | 20 °C | Relative Humidity : | 48% |
| Pressure : | 1010 hPa | Test Voltage : | DC 5.0V |
| Test Mode : | CH1(802.11g Mode) | Polarization : | Horizontal |

| Frequency (MHz) | Meter Reading (dBμV) | Factor (dB) | Emission Level (dBμV/m) | Limits (dBμV/m) | Margin (dB) | Detector Type |
|--------------------|-------------------------|----------------|----------------------------|--------------------|----------------|---------------|
| 2400 | 74.38 | -12.99 | 61.39 | 74 | -12.61 | peak |
| 2400 | 54.51 | -12.99 | 41.52 | 54 | -12.48 | AVG |
| | | | | | | |
| | | | | | | |
| | | | | | | |
| | | | | | | |

Remark:
Factor = Antenna Factor + Cable Loss – Pre-amplifier.

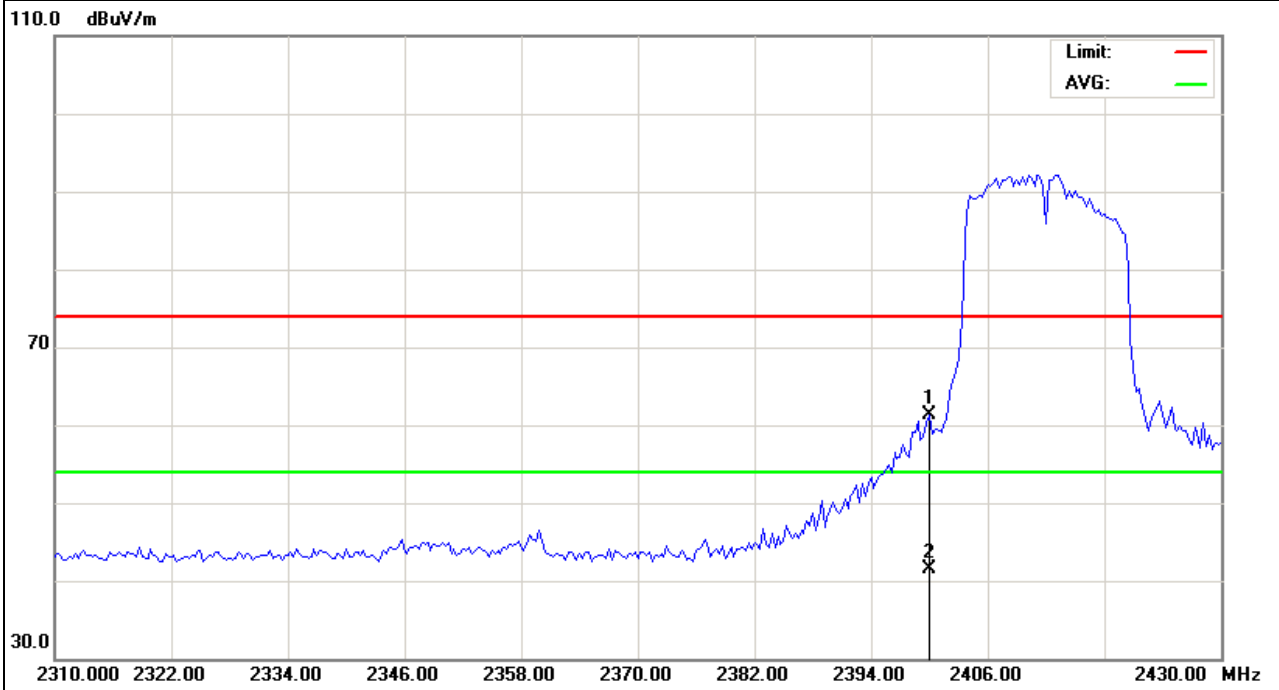

| | | | |
|---------------|------------------|---------------------|------------|
| EUT : | CDT-XX5370-00~09 | Model Name : | B0-9(5370) |
| Temperature : | 20 °C | Relative Humidity : | 48% |
| Pressure : | 1010 hPa | Test Voltage : | DC 5.0V |
| Test Mode : | CH1(802.11gMode) | Polarization : | Vertical |

| Frequency (MHz) | Meter Reading (dBμV) | Factor (dB) | Emission Level (dBμV/m) | Limits (dBμV/m) | Margin (dB) | Detector Type |
|--------------------|-------------------------|----------------|----------------------------|--------------------|----------------|---------------|
| 2400 | 75.31 | -12.99 | 62.32 | 74 | -11.68 | peak |
| 2400 | 53.99 | -12.99 | 41 | 54 | -13 | AVG |
| | | | | | | |
| | | | | | | |
| | | | | | | |
| | | | | | | |

Remark:
Factor = Antenna Factor + Cable Loss – Pre-amplifier.

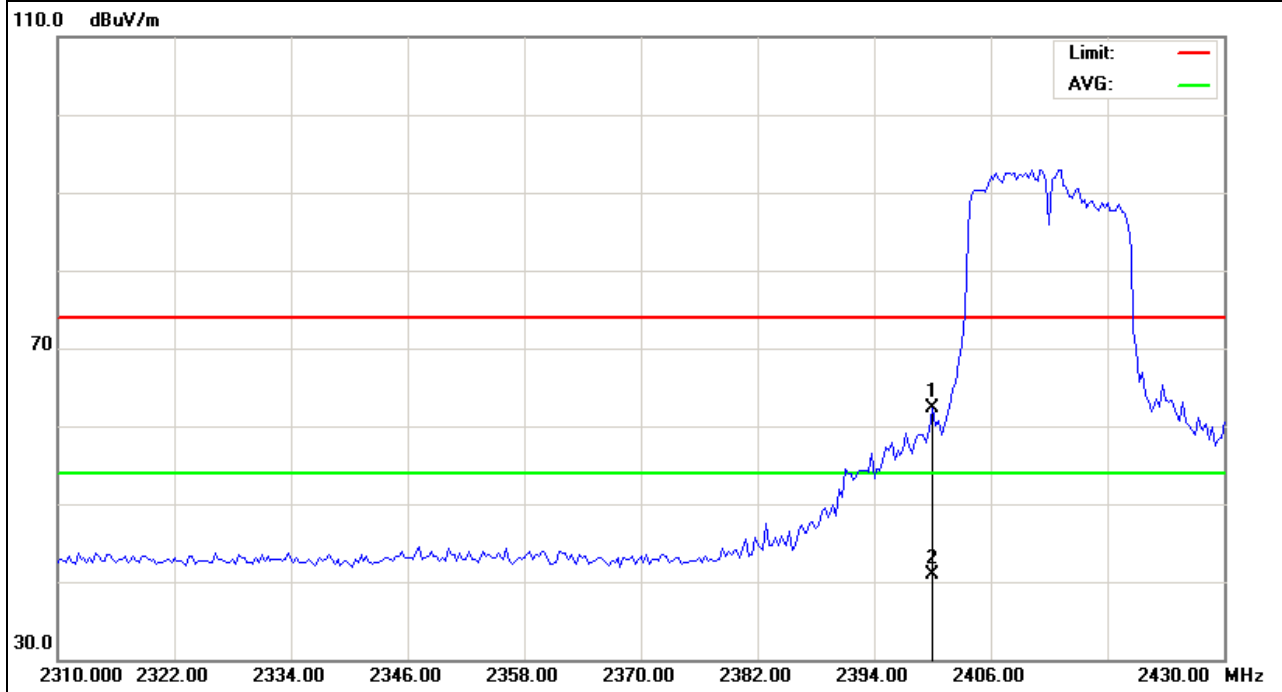

| | | | |
|---------------|--------------------|---------------------|------------|
| EUT : | CDT-XX5370-00~09 | Model Name : | B0-9(5370) |
| Temperature : | 20 °C | Relative Humidity : | 48% |
| Pressure : | 1010 hPa | Test Voltage : | DC 5.0V |
| Test Mode : | CH11(802.11g Mode) | Polarization : | Horizontal |

| Frequency (MHz) | Meter Reading (dBμV) | Factor (dB) | Emission Level (dBμV/m) | Limits (dBμV/m) | Margin (dB) | Detector Type |
|-----------------|----------------------|-------------|-------------------------|-----------------|-------------|---------------|
| 2483.5 | 75.21 | -12.78 | 62.43 | 74 | -11.57 | peak |
| 2483.5 | 56.55 | -12.78 | 43.77 | 54 | -10.23 | AVG |
| | | | | | | |
| | | | | | | |
| | | | | | | |
| | | | | | | |

Remark:
 Factor = Antenna Factor + Cable Loss – Pre-amplifier.

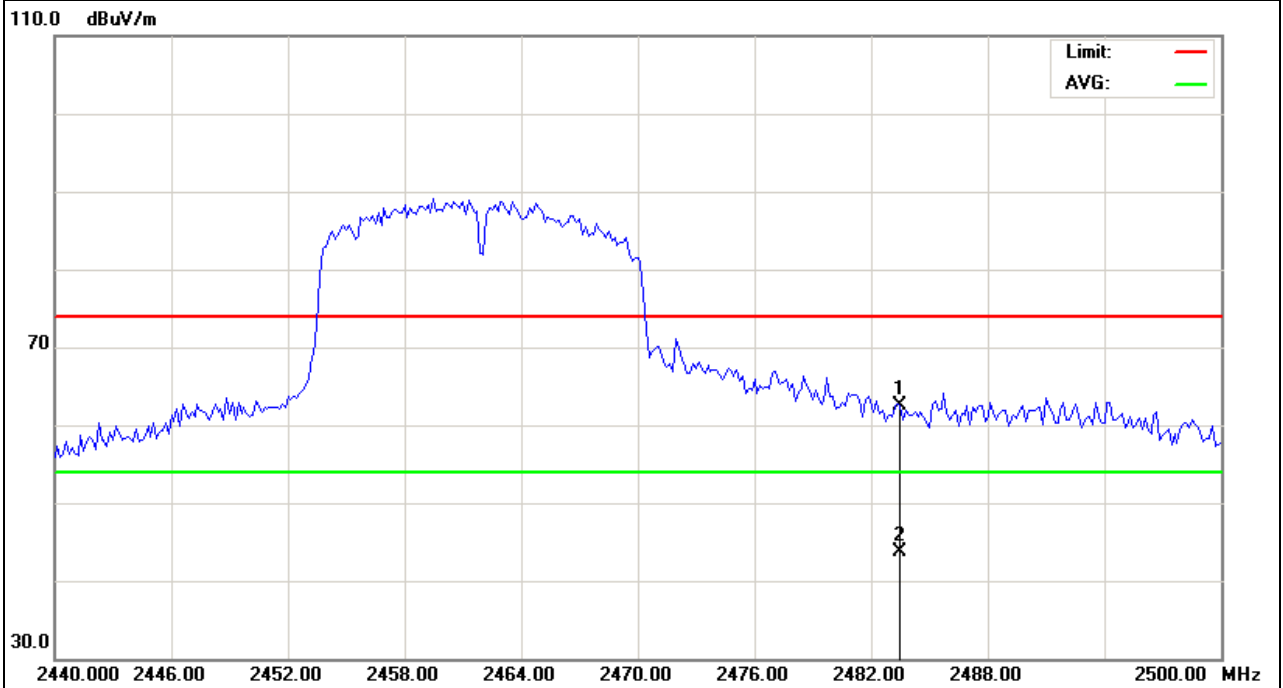

| | | | |
|---------------|--------------------|---------------------|------------|
| EUT : | CDT-XX5370-00~09 | Model Name : | B0-9(5370) |
| Temperature : | 20 °C | Relative Humidity : | 48% |
| Pressure : | 1010 hPa | Test Voltage : | DC 5.0V |
| Test Mode : | CH11(802.11g Mode) | Polarization : | Vertical |

| Frequency (MHz) | Meter Reading (dBμV) | Factor (dB) | Emission Level (dBμV/m) | Limits (dBμV/m) | Margin (dB) | Detector Type |
|--------------------|-------------------------|----------------|----------------------------|--------------------|----------------|---------------|
| 2483.5 | 75.1 | -12.78 | 62.32 | 74 | -11.68 | peak |
| 2483.5 | 54.94 | -12.78 | 42.16 | 54 | -11.84 | AVG |
| | | | | | | |
| | | | | | | |
| | | | | | | |
| | | | | | | |

Remark:
Factor = Antenna Factor + Cable Loss – Pre-amplifier.

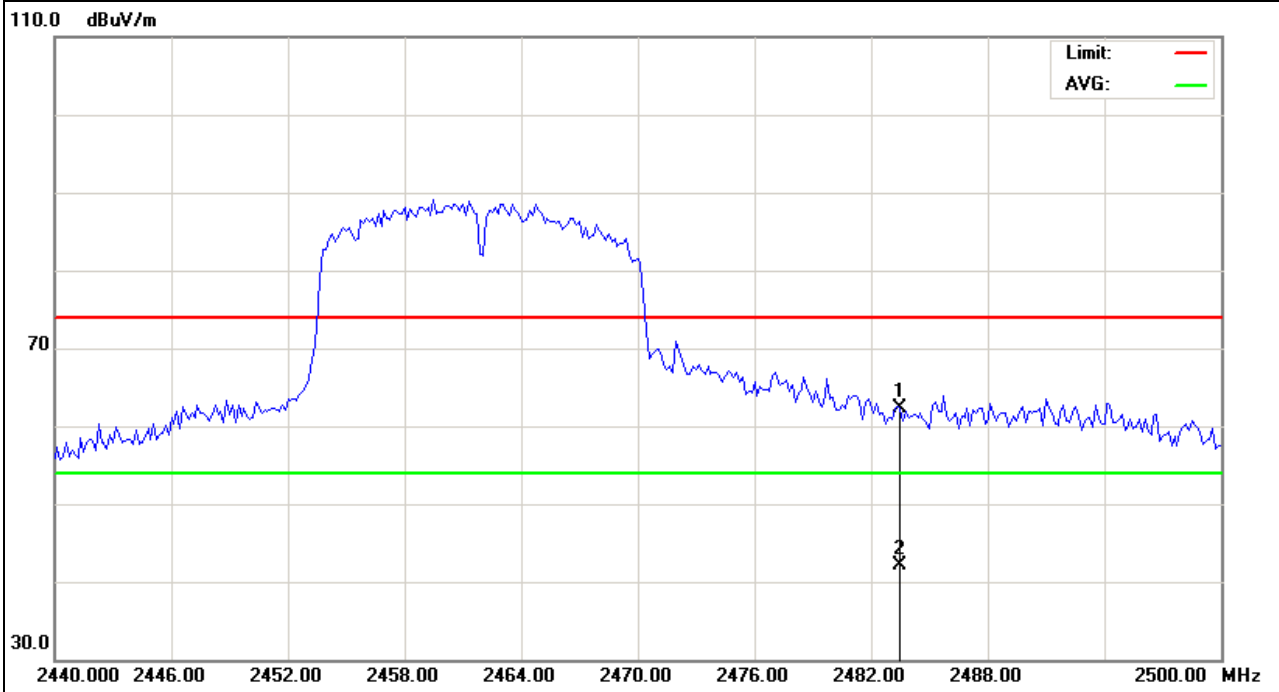

| | | | |
|---------------|-------------------------|---------------------|------------|
| EUT : | CDT-XX5370-00~09 | Model Name : | B0-9(5370) |
| Temperature : | 20 °C | Relative Humidity : | 48% |
| Pressure : | 1010 hPa | Test Voltage : | DC 5.0V |
| Test Mode : | CH1(802.11N Mode)/20MHz | Polarization : | Horizontal |

| Frequency (MHz) | Meter Reading (dBμV) | Factor (dB) | Emission Level (dBμV/m) | Limits (dBμV/m) | Margin (dB) | Detector Type |
|-----------------|----------------------|-------------|-------------------------|-----------------|-------------|---------------|
| 2400 | 68.89 | -12.99 | 55.9 | 74 | -18.1 | peak |
| 2400 | 56.26 | -12.99 | 43.27 | 54 | -10.73 | AVG |
| | | | | | | |
| | | | | | | |
| | | | | | | |
| | | | | | | |

Remark:
 Factor = Antenna Factor + Cable Loss – Pre-amplifier.

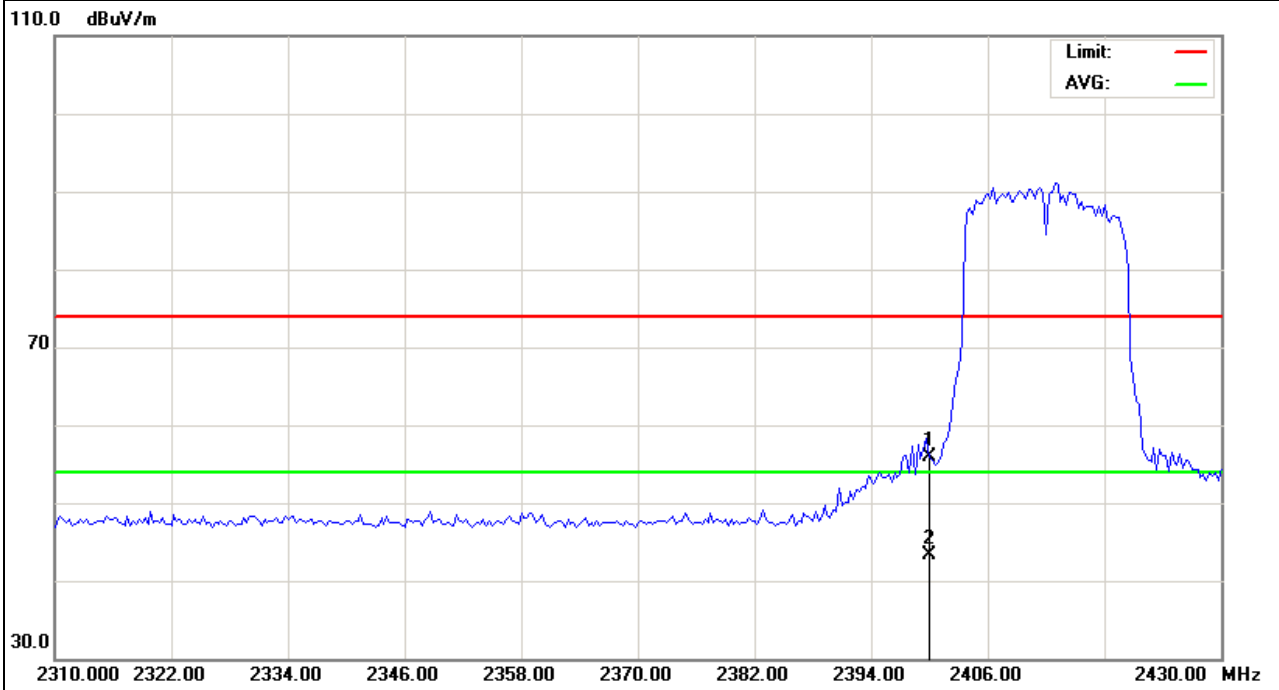

| | | | |
|---------------|-----------------------|---------------------|------------|
| EUT : | CDT-XX5370-00~09 | Model Name : | B0-9(5370) |
| Temperature : | 20 °C | Relative Humidity : | 48% |
| Pressure : | 1010 hPa | Test Voltage : | DC 5.0V |
| Test Mode : | CH1(802.11N Mode)/20M | Polarization : | Vertical |

| Frequency (MHz) | Meter Reading (dBμV) | Factor (dB) | Emission Level (dBμV/m) | Limits (dBμV/m) | Margin (dB) | Detector Type |
|--------------------|-------------------------|----------------|----------------------------|--------------------|----------------|---------------|
| 2400 | 69.53 | -12.99 | 56.54 | 74 | -17.46 | peak |
| 2400 | 56.73 | -12.99 | 43.74 | 54 | -10.26 | AVG |
| | | | | | | |
| | | | | | | |
| | | | | | | |
| | | | | | | |

Remark:
Factor = Antenna Factor + Cable Loss – Pre-amplifier.

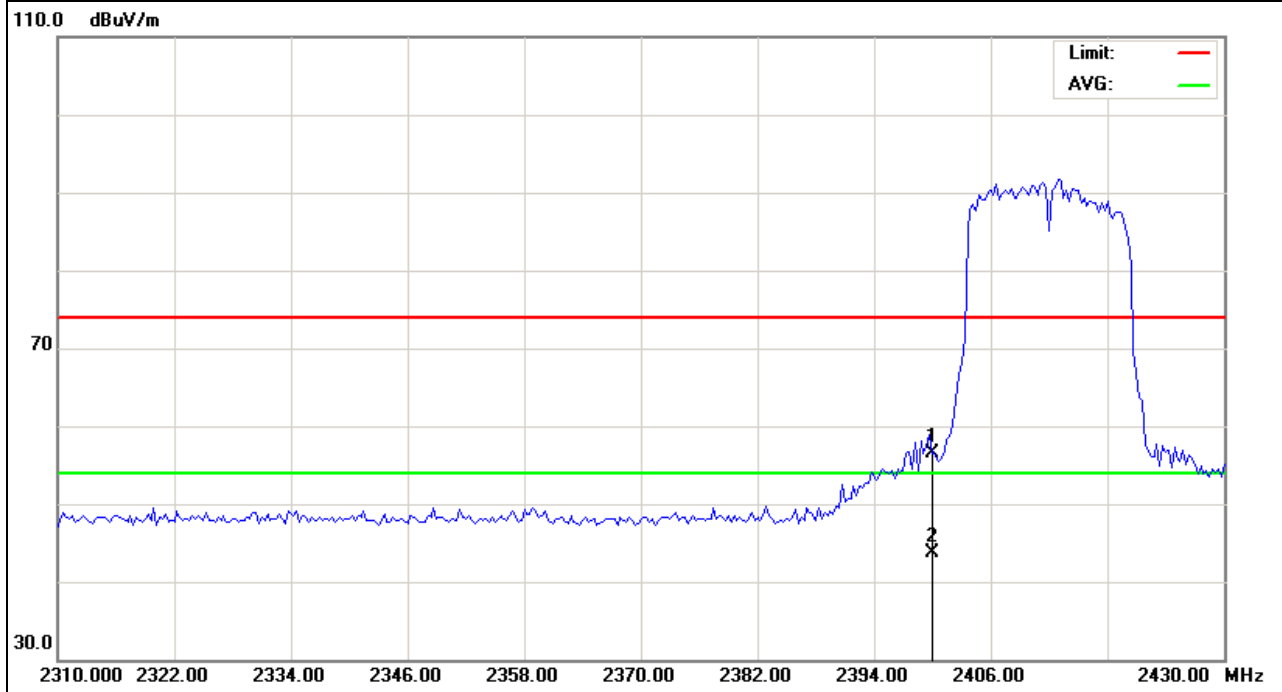

| | | | |
|---------------|--------------------------|---------------------|------------|
| EUT : | CDT-XX5370-00~09 | Model Name : | B0-9(5370) |
| Temperature : | 20 °C | Relative Humidity : | 48% |
| Pressure : | 1010 hPa | Test Voltage : | DC 5.0V |
| Test Mode : | CH11(802.11N Mode)/20MHz | Polarization : | Horizontal |

| Frequency (MHz) | Meter Reading (dBμV) | Factor (dB) | Emission Level (dBμV/m) | Limits (dBμV/m) | Margin (dB) | Detector Type |
|-----------------|----------------------|-------------|-------------------------|-----------------|-------------|---------------|
| 2483.5 | 82.03 | -12.78 | 69.25 | 74 | -4.75 | peak |
| 2483.5 | 56.87 | -12.78 | 44.09 | 54 | -9.91 | AVG |
| | | | | | | |
| | | | | | | |
| | | | | | | |
| | | | | | | |

Remark:
 Factor = Antenna Factor + Cable Loss – Pre-amplifier.

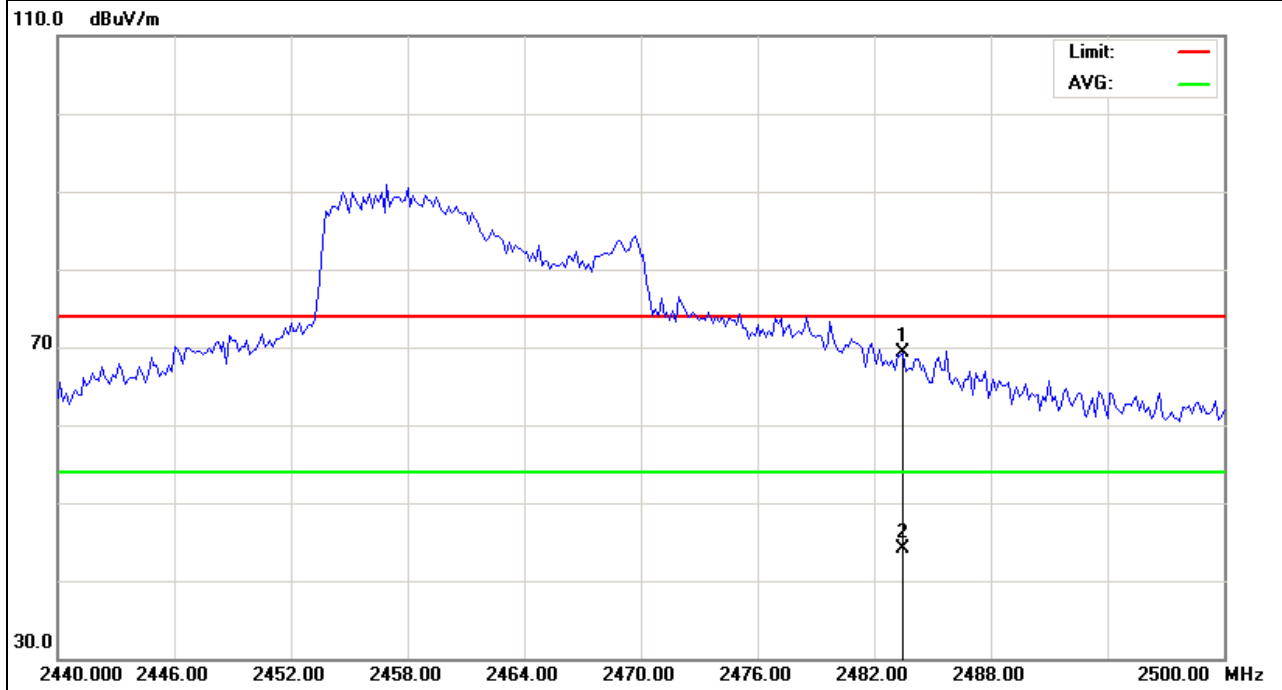

| | | | |
|---------------|--------------------------|---------------------|------------|
| EUT : | CDT-XX5370-00~09 | Model Name : | B0-9(5370) |
| Temperature : | 20 °C | Relative Humidity : | 48% |
| Pressure : | 1010 hPa | Test Voltage : | DC 5.0V |
| Test Mode : | CH11(802.11N Mode)/20MHz | Polarization : | Vertical |

| Frequency (MHz) | Meter Reading (dBμV) | Factor (dB) | Emission Level (dBμV/m) | Limits (dBμV/m) | Margin (dB) | Detector Type |
|-----------------|----------------------|-------------|-------------------------|-----------------|-------------|---------------|
| 2483.5 | 80.87 | -12.78 | 68.09 | 74 | -5.91 | peak |
| 2483.5 | 57.72 | -12.78 | 44.94 | 54 | -9.06 | AVG |
| | | | | | | |
| | | | | | | |
| | | | | | | |
| | | | | | | |

Remark:
 Factor = Antenna Factor + Cable Loss – Pre-amplifier.

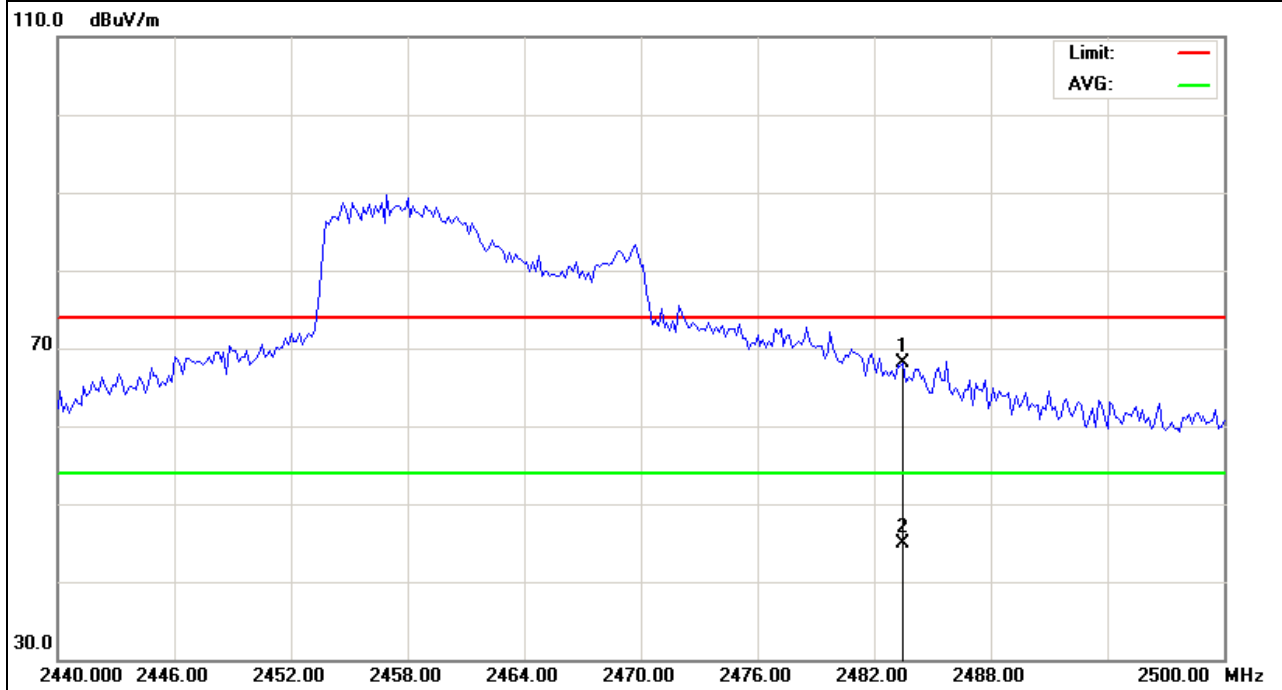

| | | | |
|---------------|-----------------------|---------------------|------------|
| EUT : | CDT-XX5370-00~09 | Model Name : | B0-9(5370) |
| Temperature : | 20 °C | Relative Humidity : | 48% |
| Pressure : | 1010 hPa | Test Voltage : | DC 5.0V |
| Test Mode : | CH3(802.11n Mode)/40M | Polarization : | Horizontal |

| Frequency (MHz) | Meter Reading (dBμV) | Factor (dB) | Emission Level (dBμV/m) | Limits (dBμV/m) | Margin (dB) | Detector Type |
|--------------------|-------------------------|----------------|----------------------------|--------------------|----------------|---------------|
| 2400 | 78.84 | -12.99 | 65.85 | 74 | -8.15 | peak |
| 2400 | 60.75 | -12.99 | 47.76 | 54 | -6.24 | AVG |
| | | | | | | |
| | | | | | | |
| | | | | | | |
| | | | | | | |

Remark:
Factor = Antenna Factor + Cable Loss – Pre-amplifier.

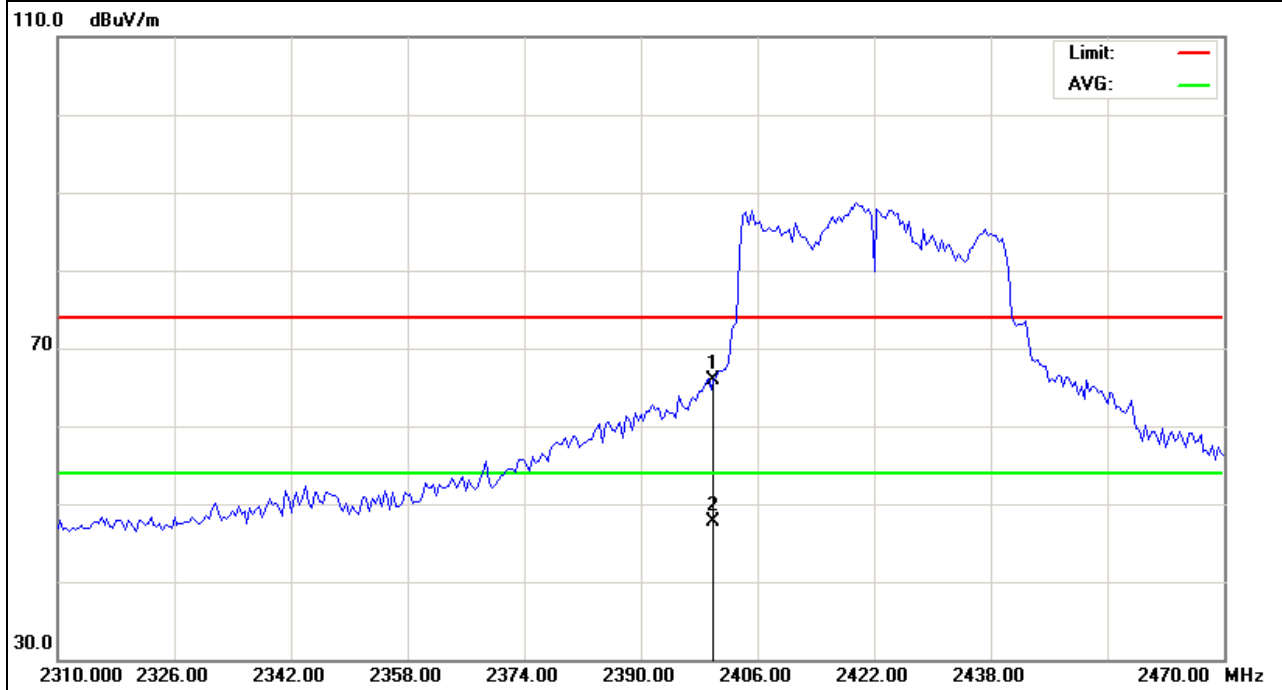

| | | | |
|---------------|-------------------------|---------------------|------------|
| EUT : | CDT-XX5370-00~09 | Model Name : | B0-9(5370) |
| Temperature : | 20 °C | Relative Humidity : | 48% |
| Pressure : | 1010 hPa | Test Voltage : | DC 5.0V |
| Test Mode : | CH3(802.11n Mode)/40MHz | Polarization : | Vertical |

| Frequency (MHz) | Meter Reading (dBμV) | Factor (dB) | Emission Level (dBμV/m) | Limits (dBμV/m) | Margin (dB) | Detector Type |
|-----------------|----------------------|-------------|-------------------------|-----------------|-------------|---------------|
| 2400 | 67.83 | -12.99 | 54.84 | 74 | -19.16 | peak |
| 2400 | 53.89 | -12.99 | 40.9 | 54 | -13.1 | AVG |
| | | | | | | |
| | | | | | | |
| | | | | | | |
| | | | | | | |

Remark:
 Factor = Antenna Factor + Cable Loss – Pre-amplifier.

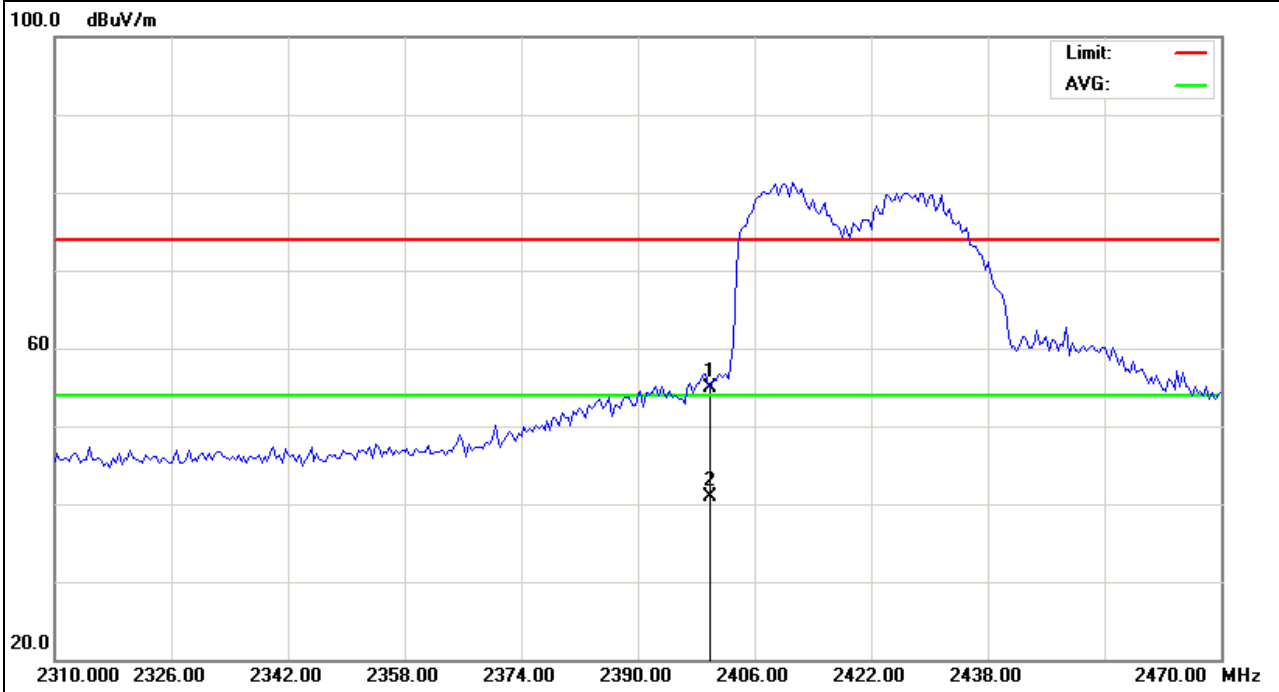

| | | | |
|---------------|-------------------------|---------------------|------------|
| EUT : | CDT-XX5370-00~09 | Model Name : | B0-9(5370) |
| Temperature : | 20 °C | Relative Humidity : | 48% |
| Pressure : | 1010 hPa | Test Voltage : | DC 5.0V |
| Test Mode : | CH9(802.11n Mode)/40MHz | Polarization : | Horizontal |

| Frequency (MHz) | Meter Reading (dBμV) | Factor (dB) | Emission Level (dBμV/m) | Limits (dBμV/m) | Margin (dB) | Detector Type |
|--------------------|-------------------------|----------------|----------------------------|--------------------|----------------|---------------|
| 2483.5 | 69.44 | -12.78 | 56.66 | 74 | -17.34 | peak |
| | | | | | | |
| | | | | | | |
| | | | | | | |
| | | | | | | |
| | | | | | | |

Remark:
Factor = Antenna Factor + Cable Loss – Pre-amplifier.

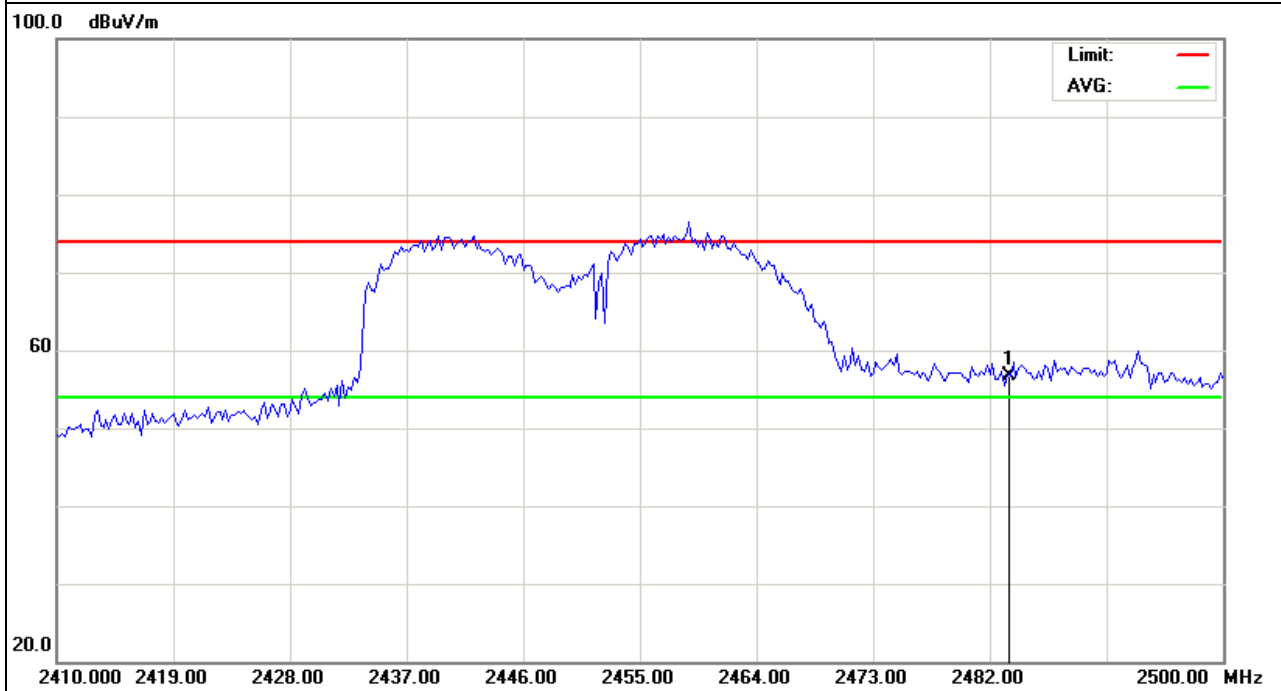

| | | | |
|---------------|-------------------------|---------------------|------------|
| EUT : | CDT-XX5370-00~09 | Model Name : | B0-9(5370) |
| Temperature : | 20 °C | Relative Humidity : | 48% |
| Pressure : | 1010 hPa | Test Voltage : | DC 5.0V |
| Test Mode : | CH9(802.11n Mode)/40MHz | Polarization : | Vertical |

| Frequency (MHz) | Meter Reading (dBμV) | Factor (dB) | Emission Level (dBμV/m) | Limits (dBμV/m) | Margin (dB) | Detector Type |
|--------------------|-------------------------|----------------|----------------------------|--------------------|----------------|---------------|
| 2483.5 | 77.57 | -12.78 | 64.79 | 74 | -9.21 | peak |
| | | | | | | |
| | | | | | | |
| | | | | | | |
| | | | | | | |

Remark:
Factor = Antenna Factor + Cable Loss – Pre-amplifier.

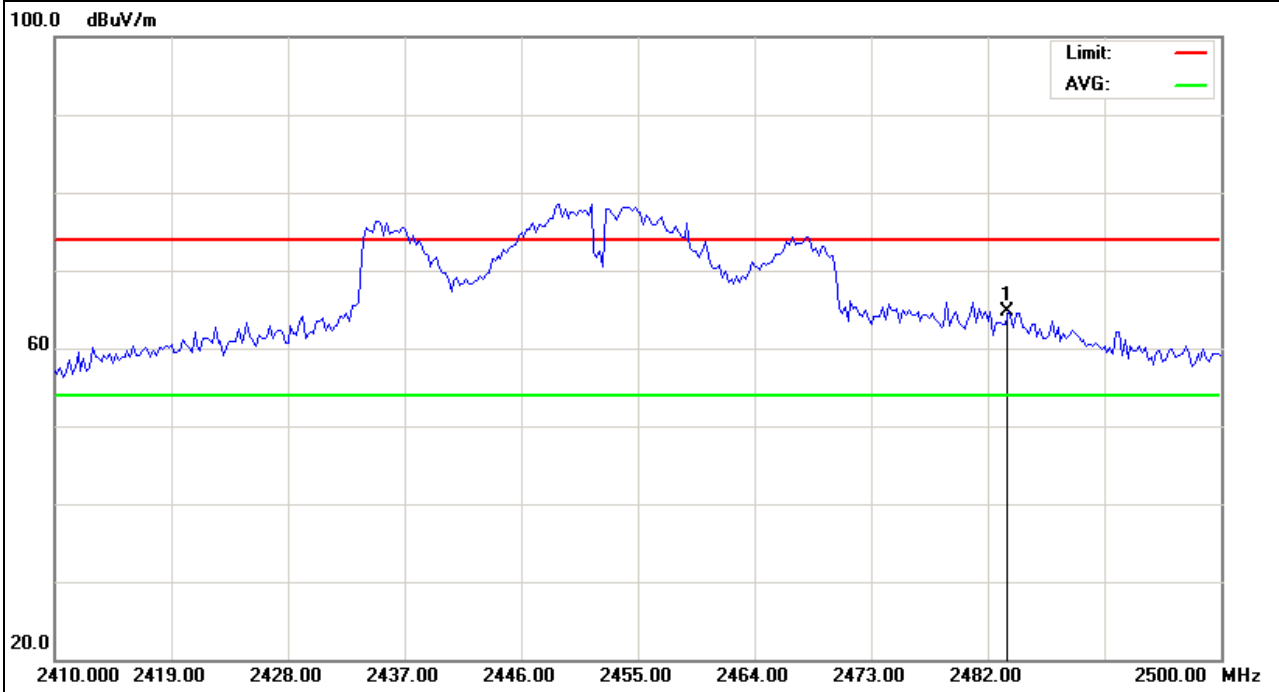

4. POWER SPECTRAL DENSITY TEST

4.1 APPLIED PROCEDURES / LIMIT

| FCC Part15 (15.247) , Subpart C | | | | |
|---------------------------------|------------------------|------------------------|-----------------------|--------|
| Section | Test Item | Limit | Frequency Range (MHz) | Result |
| 15.247 | Power Spectral Density | 8 dBm (in any 3KHz) | 2400-2483.5 | PASS |

4.1.1 TEST PROCEDURE

Referring to DTS guidance 558074 D01

1. Set analyzer center frequency to DTS channel center frequency.
2. Set the span to 1.5 times the DTS channel bandwidth.
3. Set the RBW \geq 3 kHz.
4. Set the VBW \geq 3 x RBW.
5. Detector = peak.
6. Sweep time = auto couple.
7. Trace mode = max hold.
8. Allow trace to fully stabilize.
9. Use the peak marker function to determine the maximum amplitude level.
10. If measured value exceeds limit, reduce RBW (no less than 3 kHz) and repeat.

4.1.2 DEVIATION FROM STANDARD

No deviation.

4.1.3 TEST SETUP



4.1.4 EUT OPERATION CONDITIONS

The EUT tested system was configured as the statements of 2.1 Unless otherwise a special operating condition is specified in the follows during the testing.

4.1.5 TEST RESULTS

| | | | |
|---------------|-----------------------------|---------------------|------------|
| EUT : | CDT-XX5370-00~09 | Model Name : | B0-9(5370) |
| Temperature : | 25 °C | Relative Humidity : | 60% |
| Pressure : | 1015 hPa | Test Voltage : | DC 5.0V |
| Test Mode : | TX b Mode /CH01, CH06, CH11 | | |

| Frequency | Power Density (dBm) | Limit (dBm) | Result |
|-----------|---------------------|-------------|-------------|
| 2412 MHz | -7.97 | 8 | PASS |
| 2437 MHz | -8.79 | 8 | PASS |
| 2462 MHz | -9.71 | 8 | PASS |

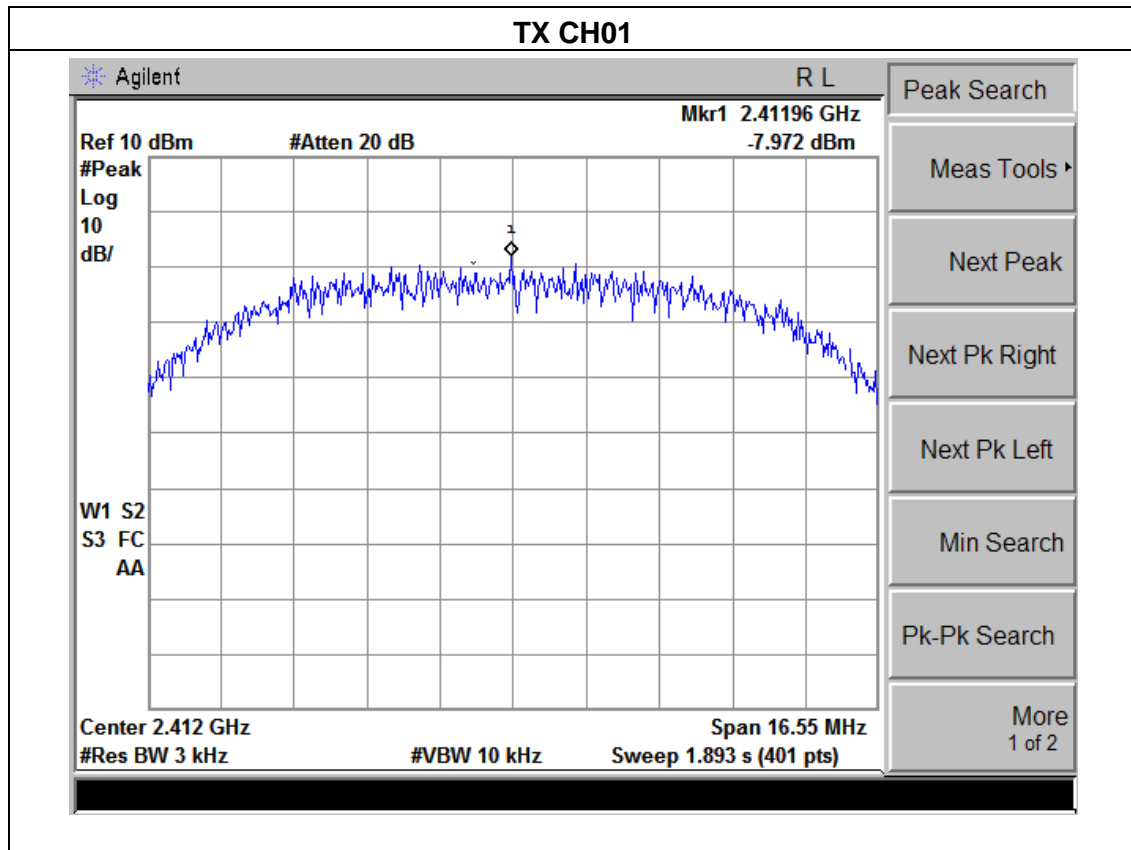

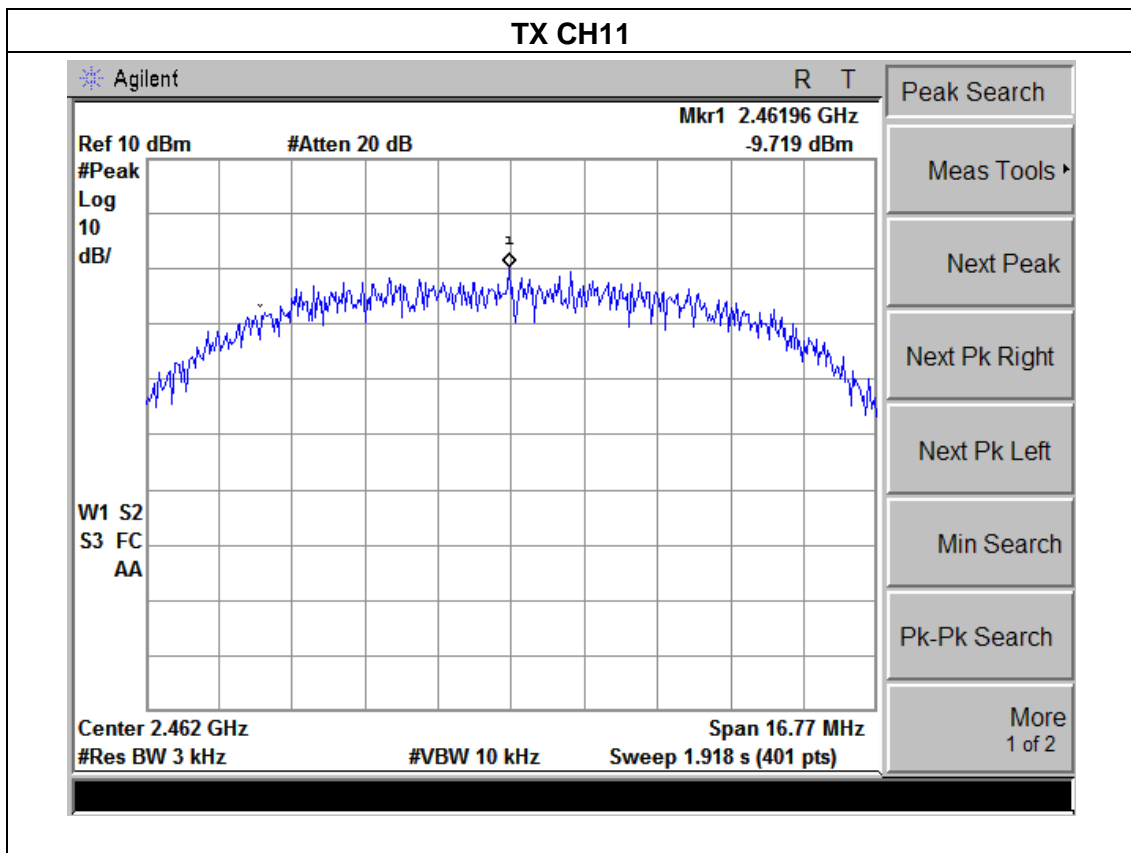
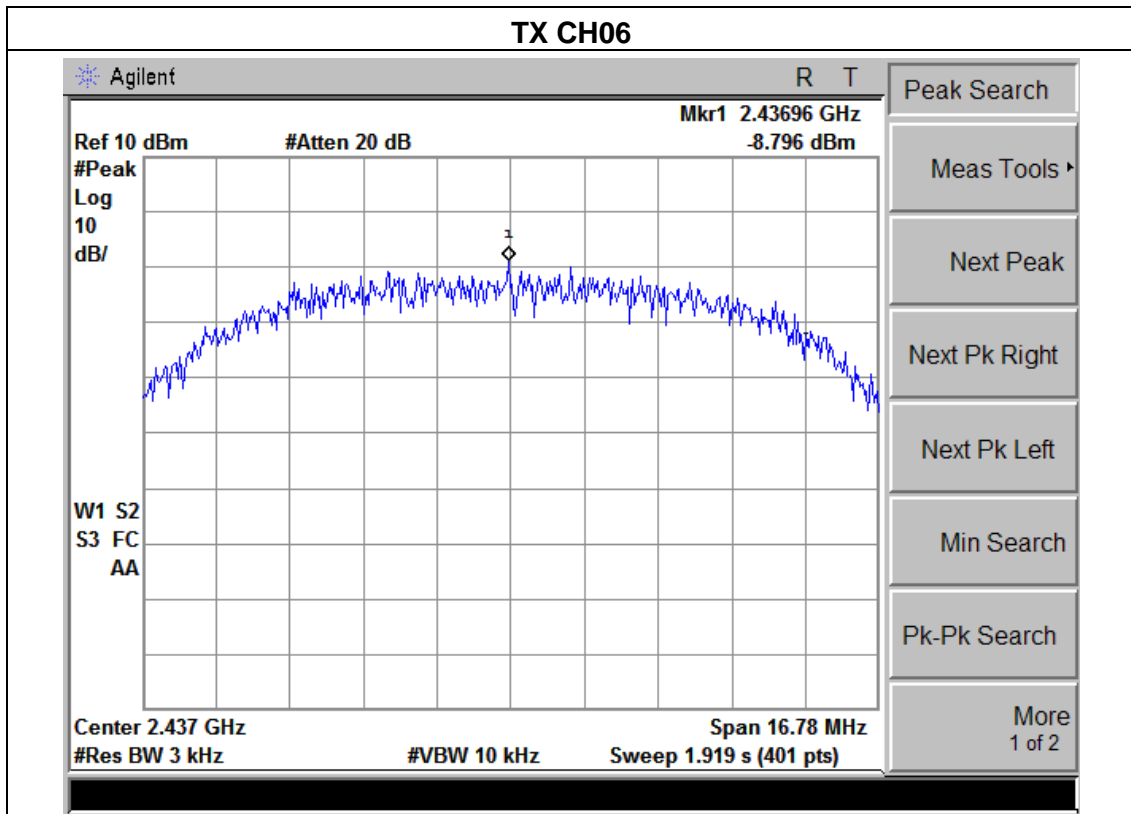

| | | | |
|---------------|-----------------------------|---------------------|------------|
| EUT : | CDT-XX5370-00~09 | Model Name : | B0-9(5370) |
| Temperature : | 25 °C | Relative Humidity : | 60% |
| Pressure : | 1015 hPa | Test Voltage : | DC 5.0V |
| Test Mode : | TX g Mode /CH01, CH06, CH11 | | |

| Frequency | Power Density (dBm) | Limit (dBm) | Result |
|-----------|---------------------|-------------|-------------|
| 2412 MHz | -10.16 | 8 | PASS |
| 2437 MHz | -11.26 | 8 | PASS |
| 2462 MHz | -10.87 | 8 | PASS |

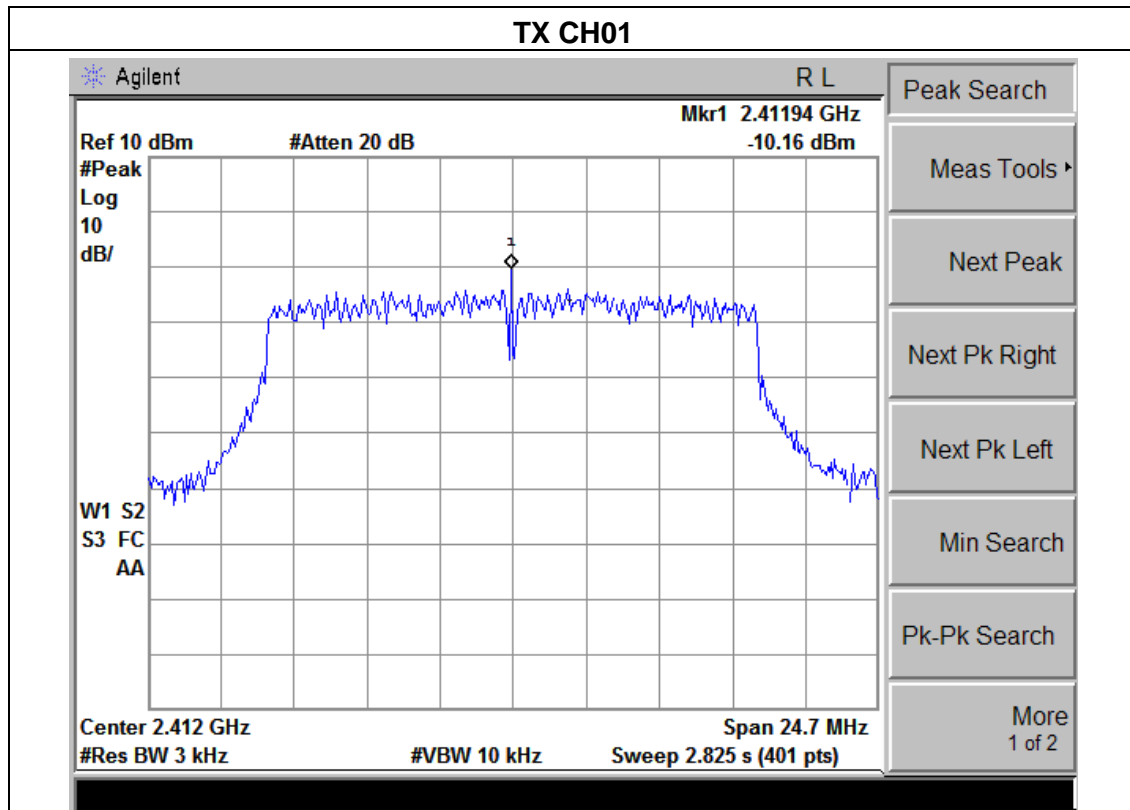

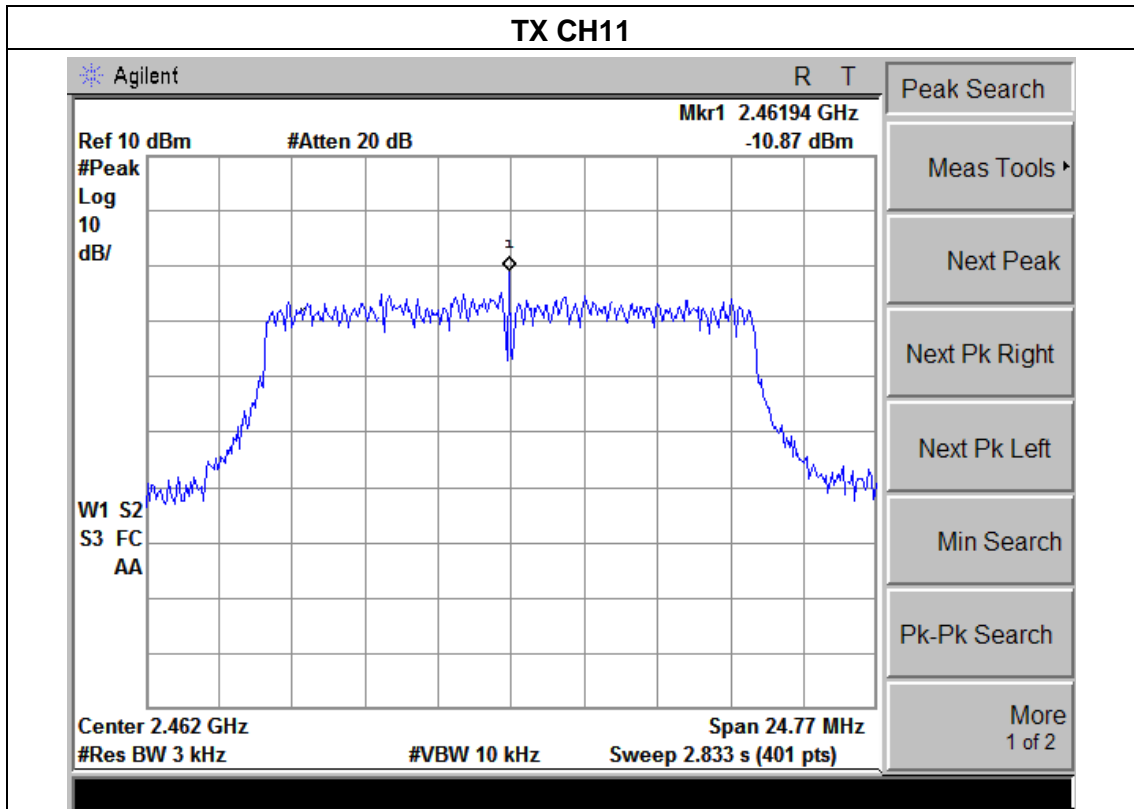
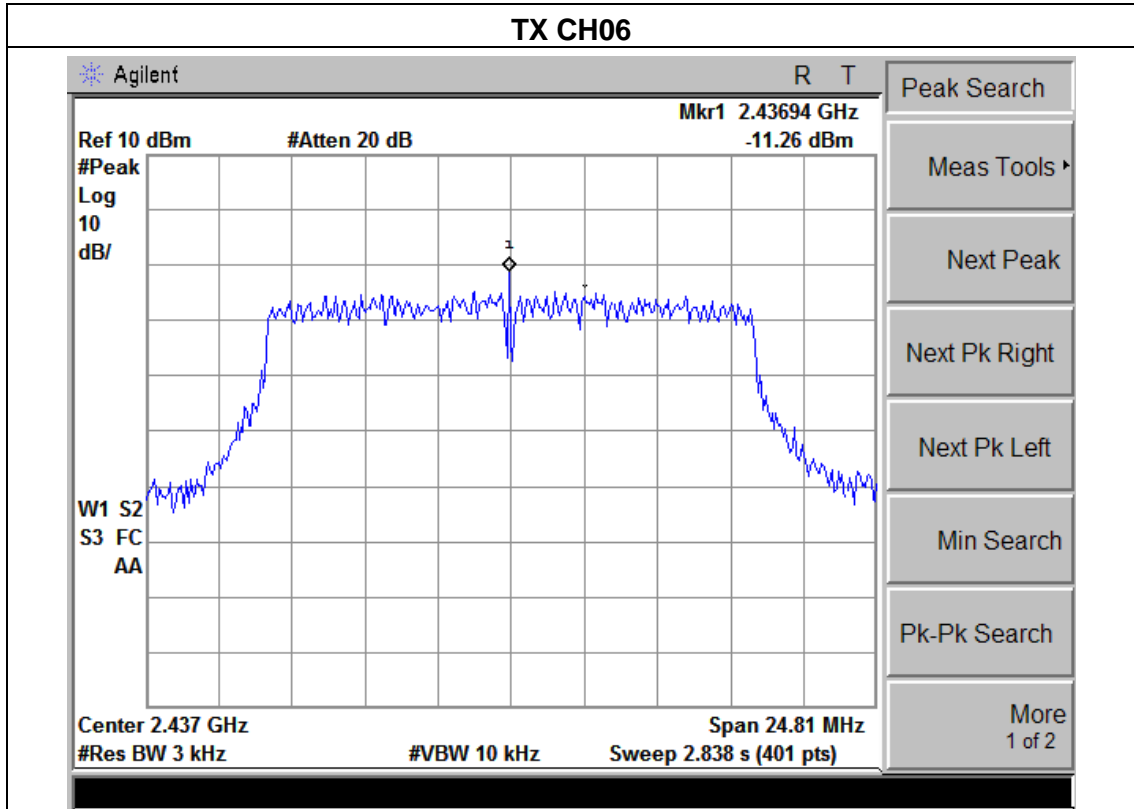

| | | | |
|---------------|----------------------------------|---------------------|------------|
| EUT : | CDT-XX5370-00~09 | Model Name : | B0-9(5370) |
| Temperature : | 25 °C | Relative Humidity : | 60% |
| Pressure : | 1015 hPa | Test Voltage : | DC 5.0V |
| Test Mode : | TX n Mode(20M) /CH01, CH06, CH11 | | |

| Frequency | Power Density (dBm) | Limit (dBm) | Result |
|-----------|---------------------|-------------|-------------|
| 2412 MHz | -9.84 | 8 | PASS |
| 2437 MHz | -11.22 | 8 | PASS |
| 2462 MHz | -11.97 | 8 | PASS |

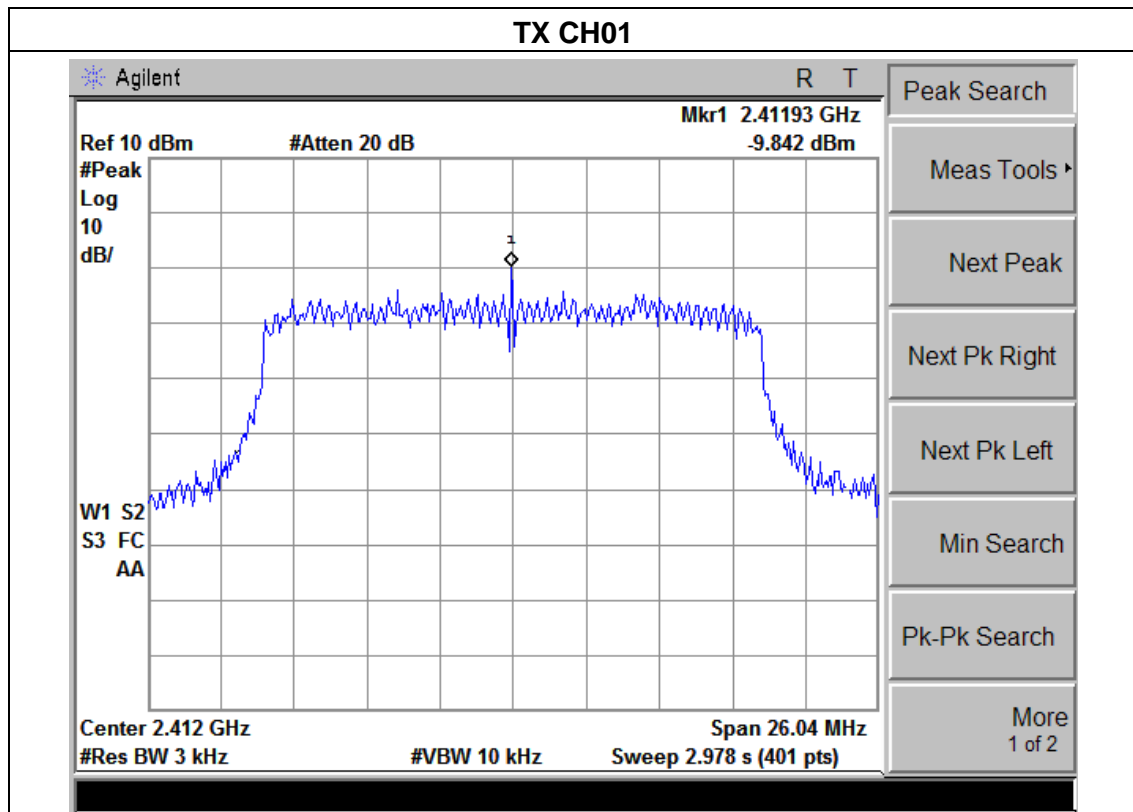

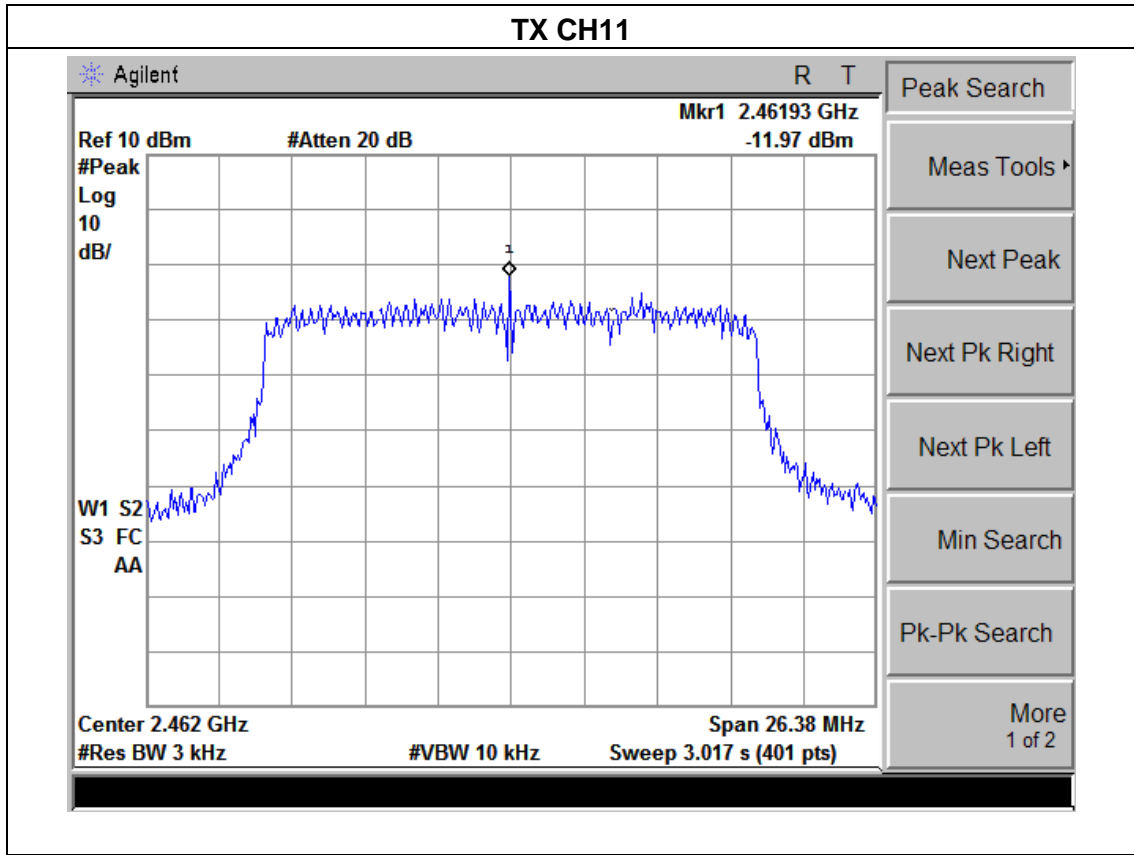
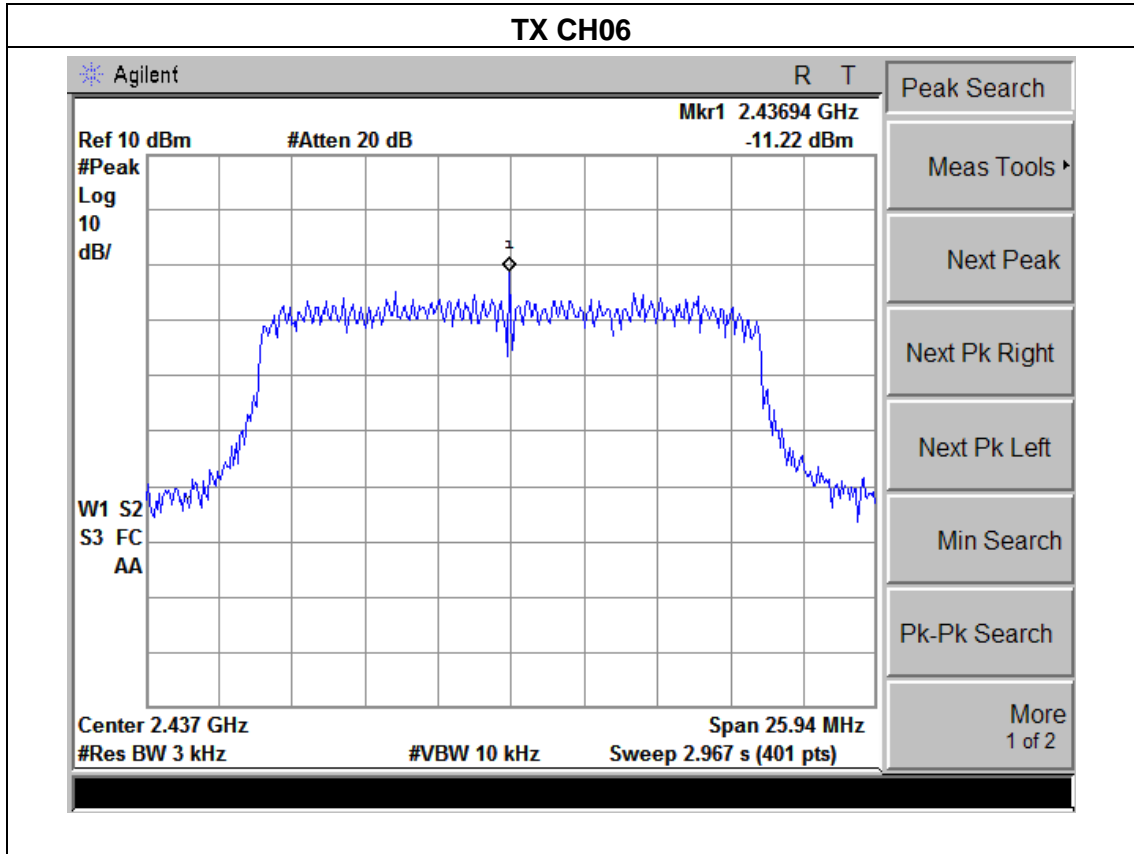

| | | | |
|---------------|----------------------------------|---------------------|------------|
| EUT : | CDT-XX5370-00~09 | Model Name : | B0-9(5370) |
| Temperature : | 25 °C | Relative Humidity : | 60% |
| Pressure : | 1015 hPa | Test Voltage : | DC 5.0V |
| Test Mode : | TX n Mode(40M) /CH03, CH06, CH09 | | |

| Frequency | Power Density (dBm) | Limit (dBm) | Result |
|-----------|---------------------|-------------|--------|
| 2422 MHz | -8.68 | 8 | PASS |
| 2437 MHz | -8.62 | 8 | PASS |
| 2452 MHz | -8.62 | 8 | PASS |

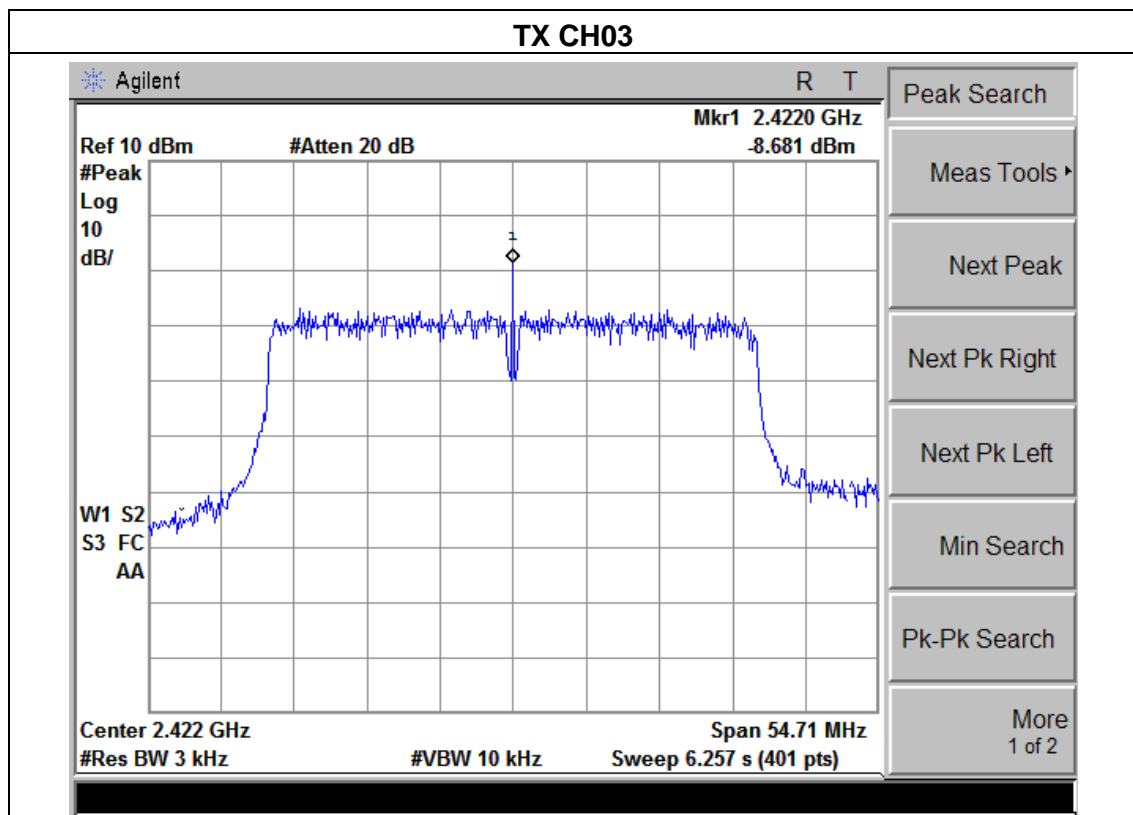

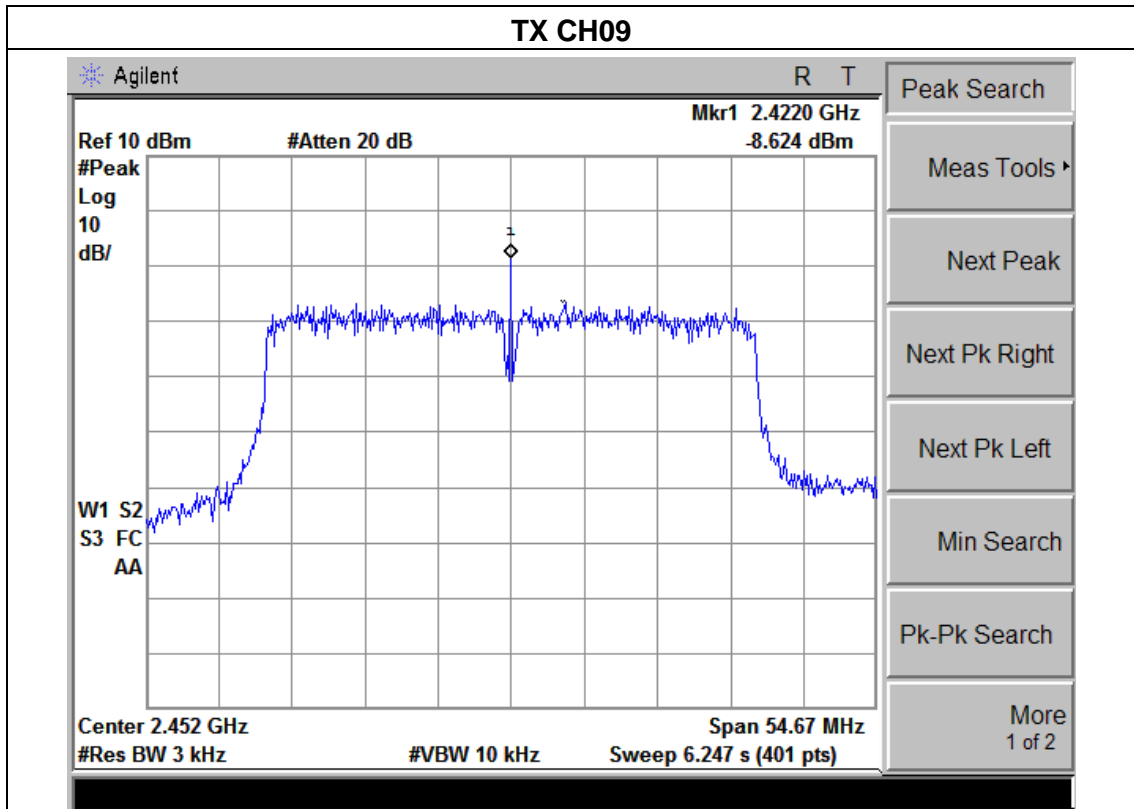
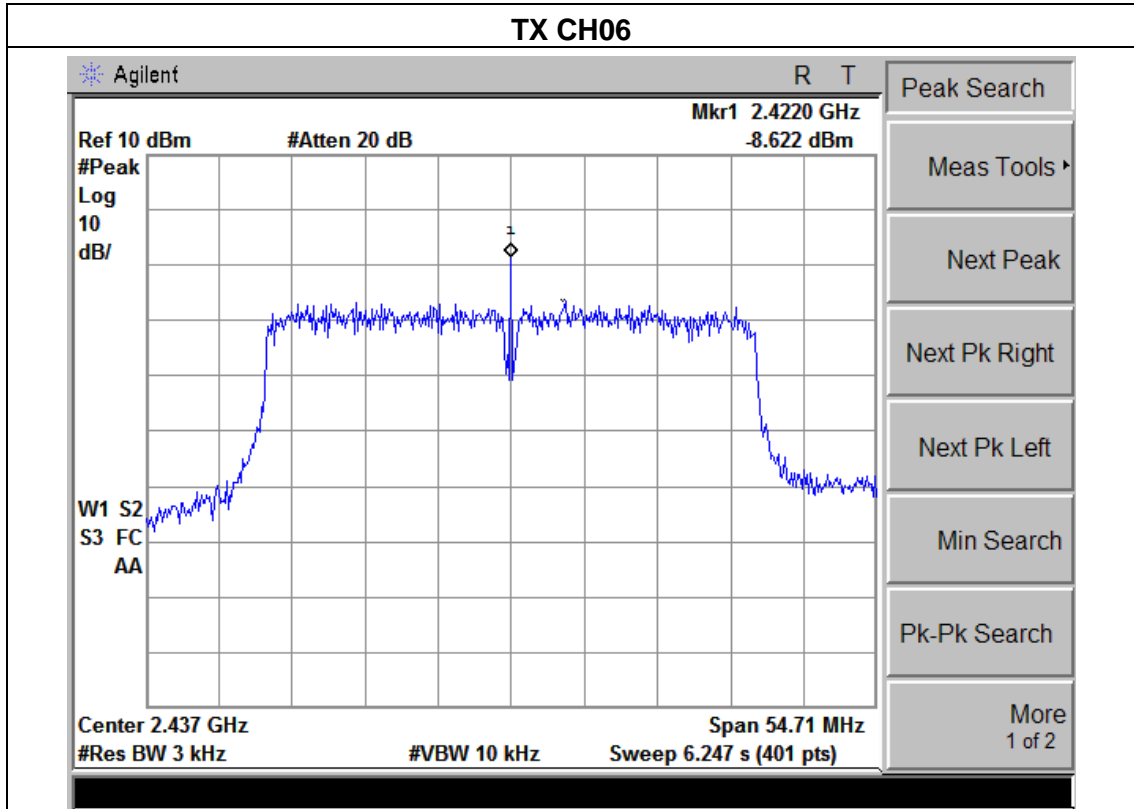

5. BANDWIDTH TEST

5.1 APPLIED PROCEDURES / LIMIT

| FCC Part15 (15.247) , Subpart C | | | | |
|---------------------------------|-----------|---|-----------------------|--------|
| Section | Test Item | Limit | Frequency Range (MHz) | Result |
| 15.247(a)(2) | Bandwidth | $\geq 500\text{KHz}$ (6dB bandwidth) | 2400-2483.5 | PASS |

5.1.1 TEST PROCEDURE

a.

1. Set resolution bandwidth (RBW) = 1-5% or DTS BW, not to exceed 100 kHz.
2. Set the video bandwidth (VBW) $\geq 3 \times$ RBW.
3. Detector = Peak.
4. Trace mode = max hold.
5. Sweep = auto couple.
6. Allow the trace to stabilize.
7. Measure the maximum width of the emission that is constrained by the frequencies associated with the two outermost amplitude points (upper and lower) that are attenuated by 6 dB relative to the maximum level measured in the fundamental emission.

5.1.2 DEVIATION FROM STANDARD

No deviation.

5.1.3 TEST SETUP



5.1.4 EUT OPERATION CONDITIONS

The EUT tested system was configured as the statements of 2.4 Unless otherwise a special operating condition is specified in the follows during the testing.

5.1.5 TEST RESULTS

| | | | |
|---------------|-----------------------------|---------------------|------------|
| EUT : | CDT-XX5370-00~09 | Model Name : | B0-9(5370) |
| Temperature : | 25 °C | Relative Humidity : | 60% |
| Pressure : | 1012 hPa | Test Voltage : | DC 5.0V |
| Test Mode : | TX b Mode /CH01, CH06, CH11 | | |

| Frequency | 6dB Bandwidth (MHz) | 99% Occupied BW (MHz) | Channel Separation (MHz) | Result |
|-----------|---------------------|-----------------------|--------------------------|-------------|
| 2412 MHz | 11.03 | 14.44 | >=500KHz | PASS |
| 2437 MHz | 11.18 | 14.38 | >=500KHz | PASS |
| 2462 MHz | 11.18 | 14.40 | >=500KHz | PASS |

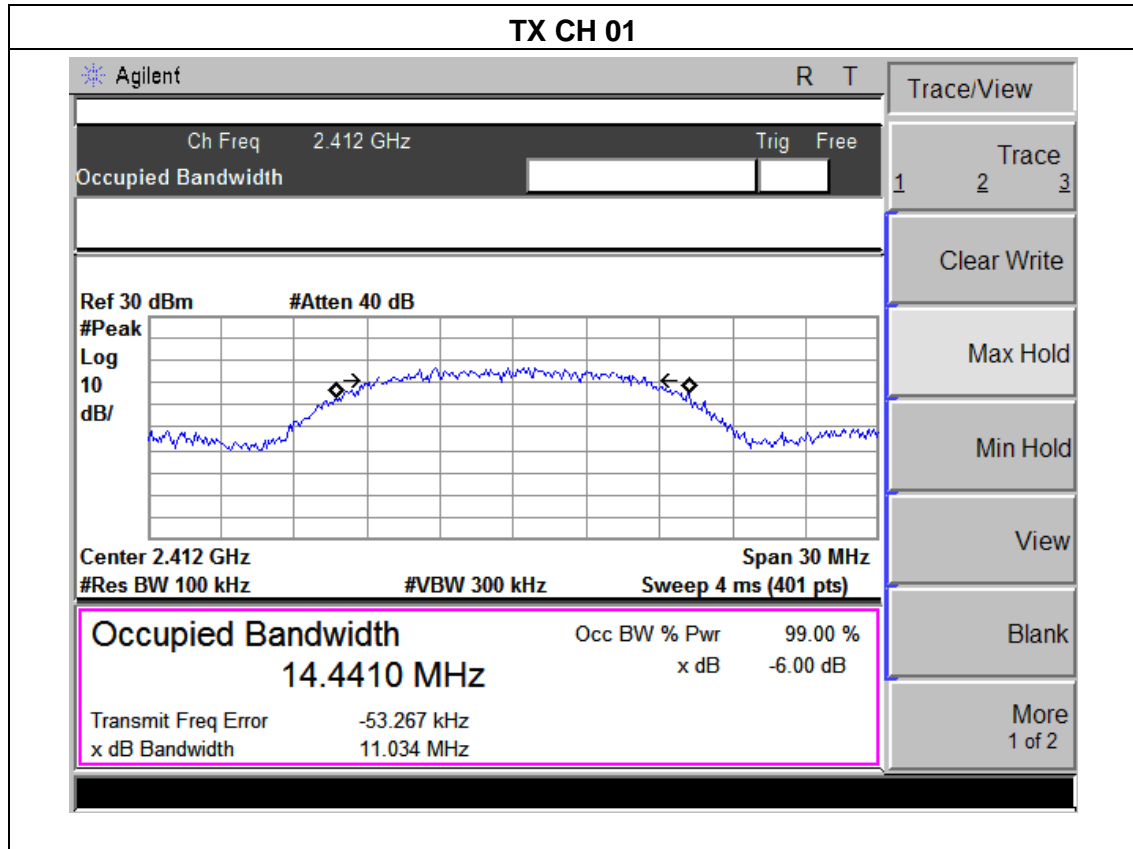

TX CH 06

Agilent
R T

Ch Freq 2.437 GHz Trig Free

Occupied Bandwidth

Ref 30 dBm #Atten 40 dB

#Peak Log 10 dB/

Center 2.437 GHz Span 30 MHz
#Res BW 100 kHz #VBW 300 kHz Sweep 4 ms (401 pts)

| | | |
|---------------------------|--------------|----------|
| Occupied Bandwidth | Occ BW % Pwr | 99.00 % |
| 14.3833 MHz | x dB | -6.00 dB |
| Transmit Freq Error | -54.509 kHz | |
| x dB Bandwidth | 11.184 MHz | |

Trace/View

Trace 1 2 3

Clear Write

Max Hold

Min Hold

View

Blank

More 1 of 2

TX CH 11

Agilent
R T

Ch Freq 2.462 GHz Trig Free

Occupied Bandwidth

Ref 30 dBm #Atten 40 dB

#Peak Log 10 dB/

Center 2.462 GHz Span 30 MHz
#Res BW 100 kHz #VBW 300 kHz Sweep 4 ms (401 pts)

| | | |
|---------------------------|--------------|----------|
| Occupied Bandwidth | Occ BW % Pwr | 99.00 % |
| 14.4093 MHz | x dB | -6.00 dB |
| Transmit Freq Error | -70.418 kHz | |
| x dB Bandwidth | 11.180 MHz | |

Freq/Channel

Center Freq 2.46200000 GHz

Start Freq 2.44700000 GHz

Stop Freq 2.47700000 GHz

CF Step 3.00000000 MHz
Auto Man

Freq Offset 0.00000000 Hz

Signal Track On Off

Scale Type Log Lin

| | | | |
|---------------|-----------------------------|---------------------|------------|
| EUT : | CDT-XX5370-00~09 | Model Name : | B0-9(5370) |
| Temperature : | 25 °C | Relative Humidity : | 60% |
| Pressure : | 1012 hPa | Test Voltage : | DC 5.0V |
| Test Mode : | TX g Mode /CH01, CH06, CH11 | | |

| Frequency | 6dB Bandwidth (MHz) | 99% Occupied BW (MHz) | Channel Separation (MHz) | Result |
|-----------|---------------------|-----------------------|--------------------------|-------------|
| 2412 MHz | 16.47 | 16.44 | >=500KHz | PASS |
| 2437 MHz | 16.54 | 16.43 | >=500KHz | PASS |
| 2462 MHz | 16.51 | 16.41 | >=500KHz | PASS |

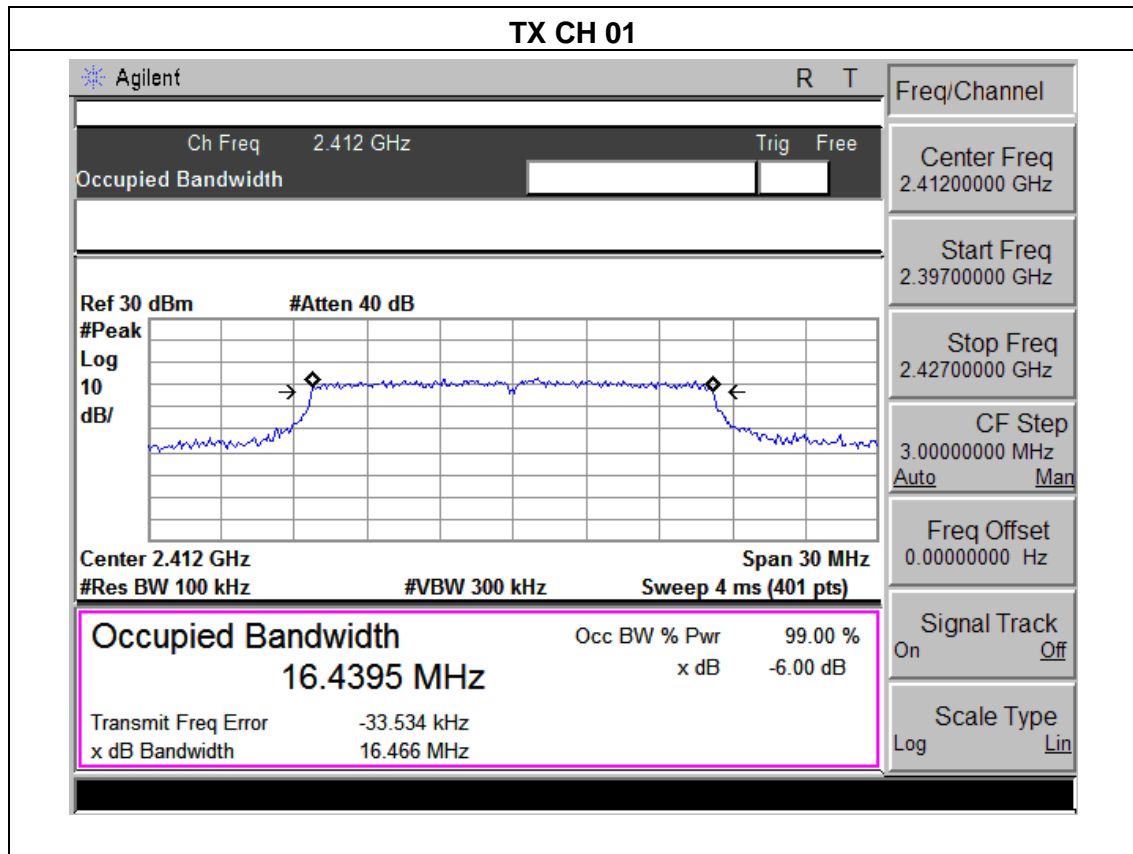

TX CH 06

Agilent R T

Ch Freq 2.437 GHz Trig Free

Occupied Bandwidth [] []

Ref 30 dBm #Atten 40 dB

#Peak
Log
10
dB/

Center 2.437 GHz Span 30 MHz

#Res BW 100 kHz #VBW 300 kHz Sweep 4 ms (401 pts)

Occupied Bandwidth Occ BW % Pwr 99.00 %

16.4341 MHz x dB -6.00 dB

Transmit Freq Error -36.686 kHz

x dB Bandwidth 16.543 MHz

Freq/Channel

Center Freq 2.43700000 GHz

Start Freq 2.42200000 GHz

Stop Freq 2.45200000 GHz

CF Step 3.00000000 MHz
Auto Man

Freq Offset 0.00000000 Hz

Signal Track On Off

Scale Type Log Lin

TX CH 11

Agilent R T

Ch Freq 2.462 GHz Trig Free

Occupied Bandwidth [] []

Ref 30 dBm #Atten 40 dB

#Peak
Log
10
dB/

Center 2.462 GHz Span 30 MHz

#Res BW 100 kHz #VBW 300 kHz Sweep 4 ms (401 pts)

Occupied Bandwidth Occ BW % Pwr 99.00 %

16.4081 MHz x dB -6.00 dB

Transmit Freq Error -40.877 kHz

x dB Bandwidth 16.510 MHz

Trace/View

Trace 1 2 3

Clear Write

Max Hold

Min Hold

View

Blank

More 1 of 2

| | | | |
|---------------|----------------------------------|---------------------|------------|
| EUT : | CDT-XX5370-00~09 | Model Name : | B0-9(5370) |
| Temperature : | 25 °C | Relative Humidity : | 60% |
| Pressure : | 1012 hPa | Test Voltage : | DC 5.0V |
| Test Mode : | TX n Mode(20M) /CH01, CH06, CH11 | | |

| Frequency | 6dB Bandwidth (MHz) | 99% Occupied BW (MHz) | Channel Separation (MHz) | Result |
|-----------|---------------------|-----------------------|--------------------------|-------------|
| 2412 MHz | 17.36 | 17.50 | >=500KHz | PASS |
| 2437 MHz | 17.29 | 17.46 | >=500KHz | PASS |
| 2462 MHz | 17.59 | 17.47 | >=500KHz | PASS |

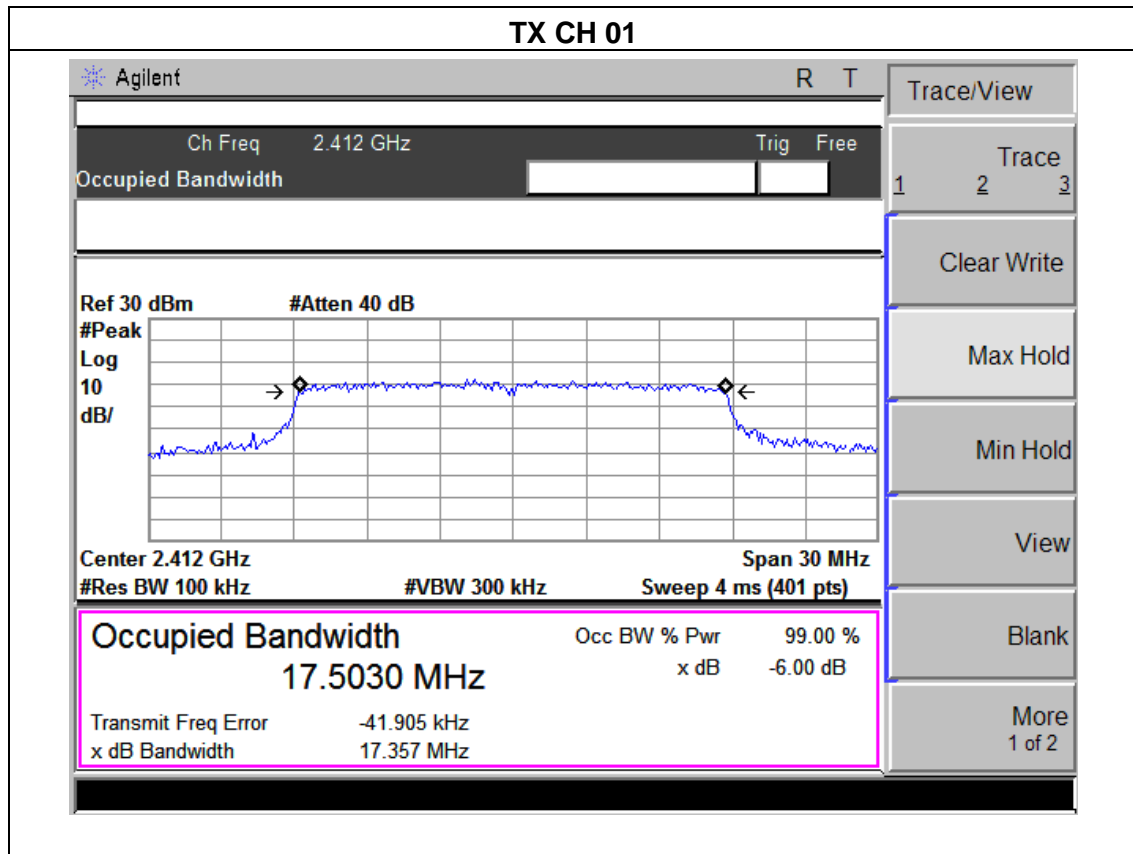

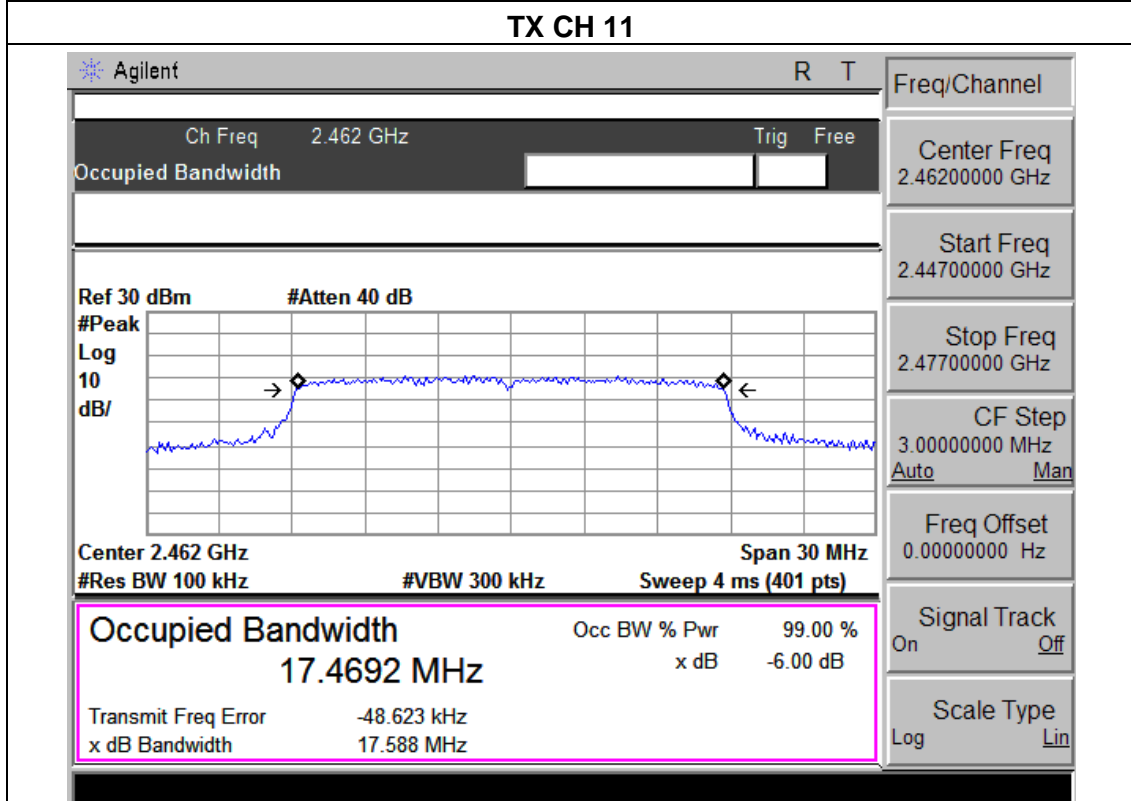
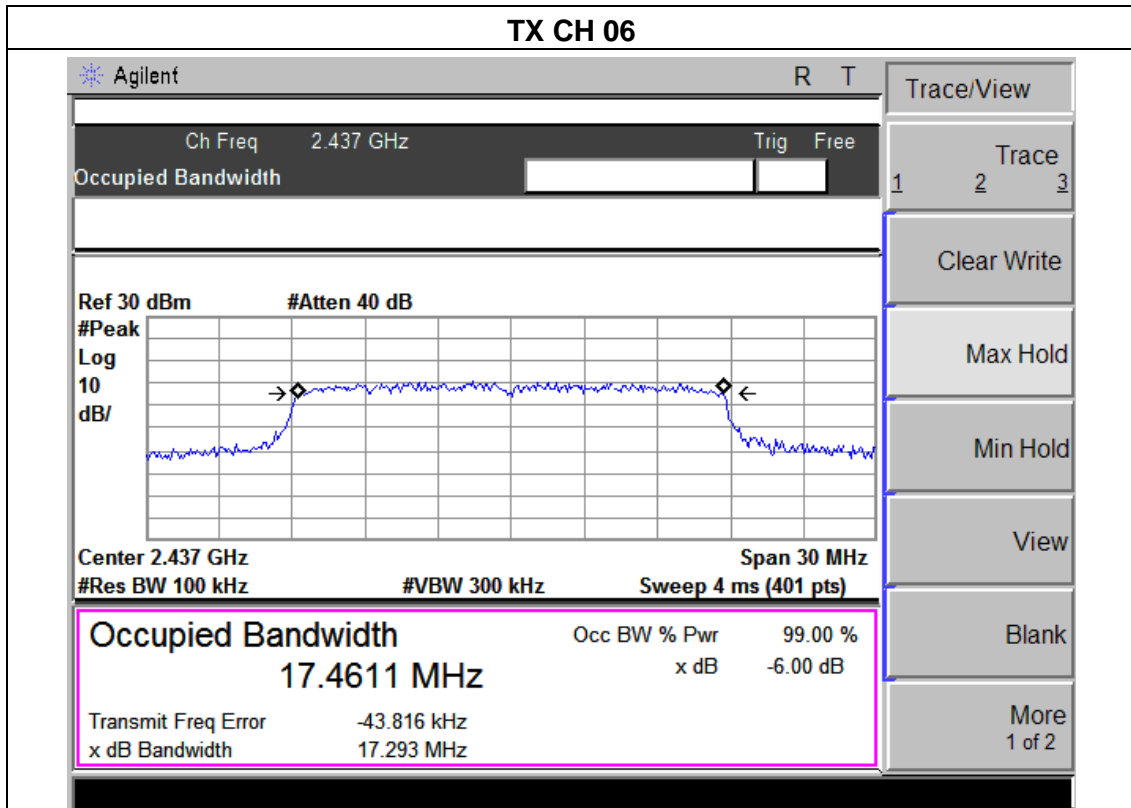

| | | | |
|---------------|----------------------------------|---------------------|------------|
| EUT : | CDT-XX5370-00~09 | Model Name : | B0-9(5370) |
| Temperature : | 25 °C | Relative Humidity : | 60% |
| Pressure : | 1012 hPa | Test Voltage : | DC 5.0V |
| Test Mode : | TX n Mode(40M) /CH03, CH06, CH09 | | |

| Frequency | 6dB Bandwidth (MHz) | 99% Occupied BW (MHz) | Channel Separation (MHz) | Result |
|-----------|---------------------|-----------------------|--------------------------|-------------|
| 2422 MHz | 36.47 | 35.99 | >=500KHz | PASS |
| 2437 MHz | 36.47 | 36.05 | >=500KHz | PASS |
| 2452 MHz | 36.45 | 35.98 | >=500KHz | PASS |

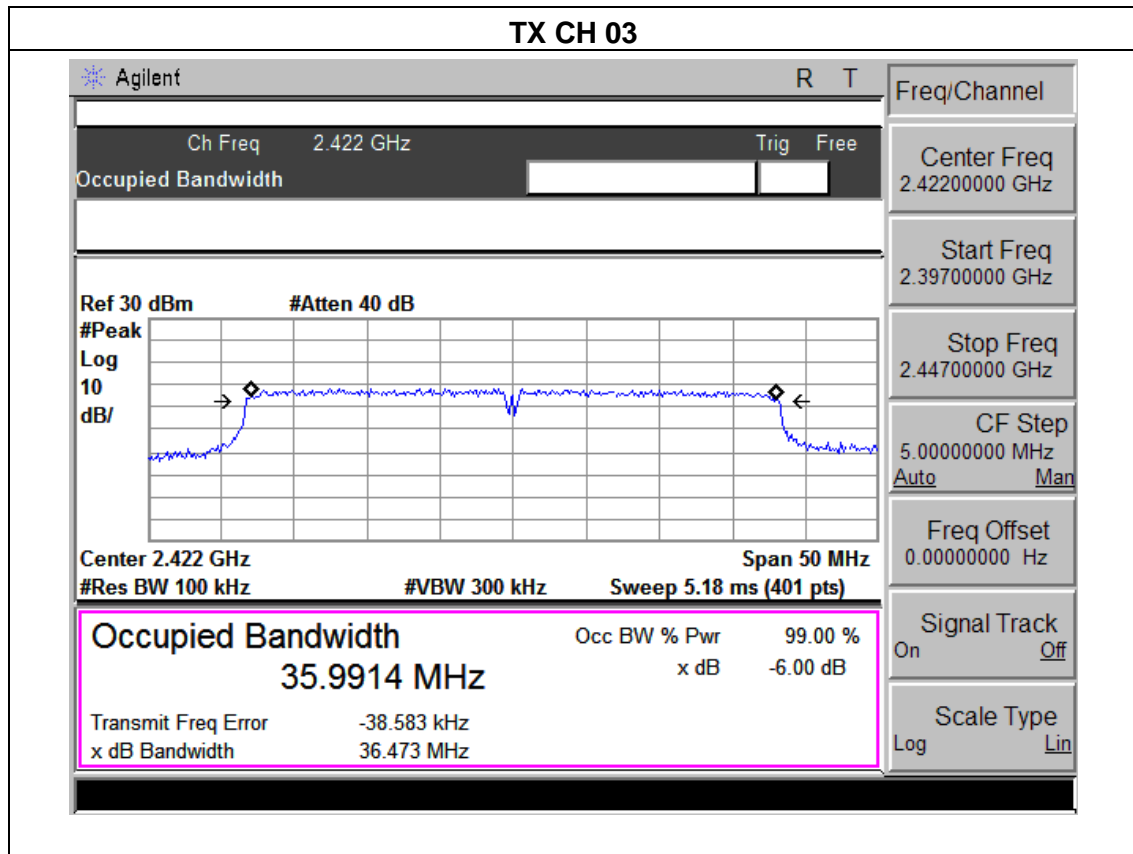

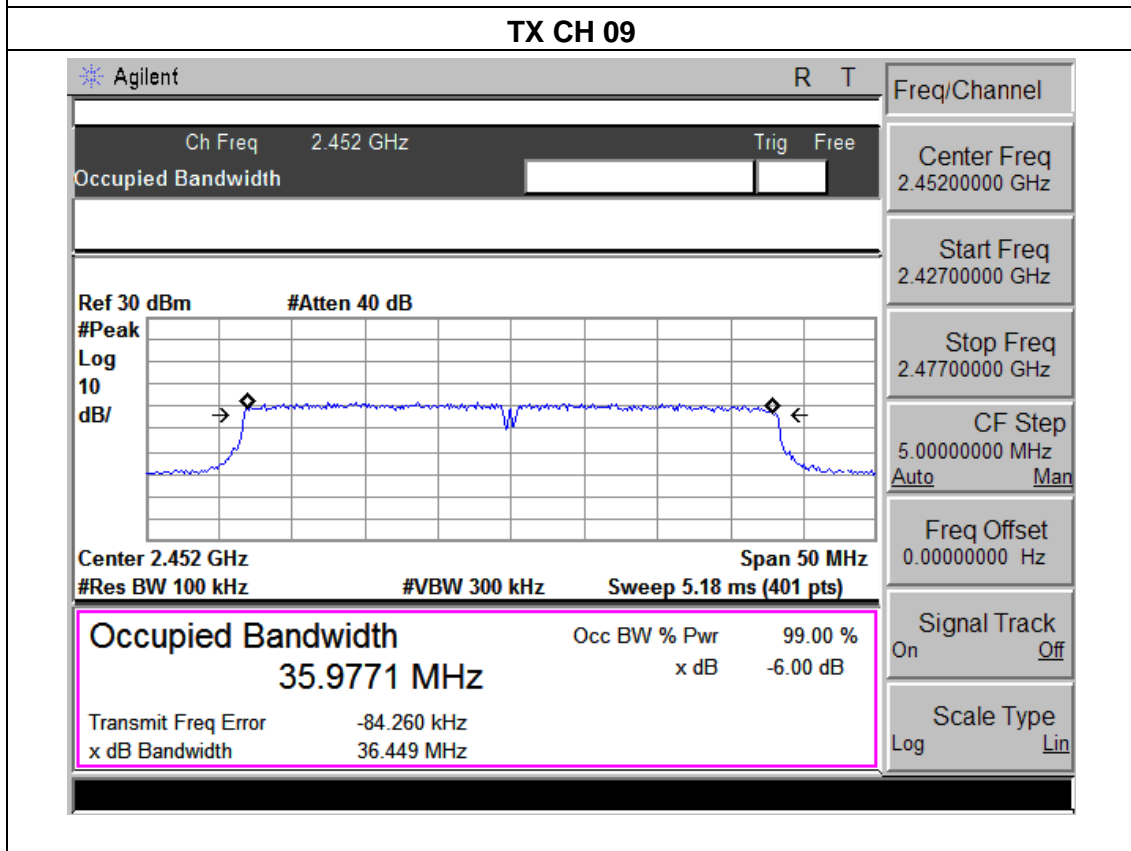
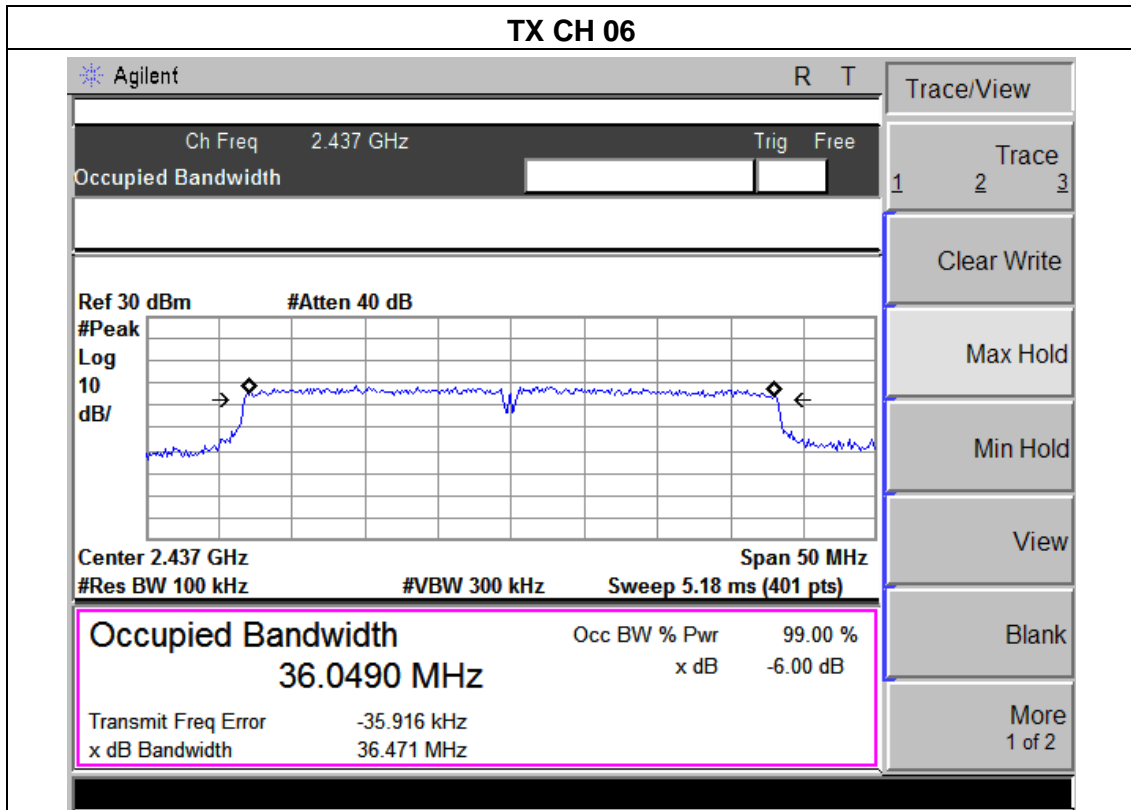

6. PEAK OUTPUT POWER TEST

6.1 APPLIED PROCEDURES / LIMIT

| FCC Part15 (15.247) , Subpart C | | | | |
|---------------------------------|-------------------|-----------------|-----------------------|--------|
| Section | Test Item | Limit | Frequency Range (MHz) | Result |
| 15.247(b)(3) | Peak Output Power | 1 watt or 30dBm | 2400-2483.5 | PASS |

6.1.1 TEST PROCEDURE

- a. The EUT was directly connected to the Power meter

6.1.2 DEVIATION FROM STANDARD

No deviation.

6.1.3 TEST SETUP



6.1.4 EUT OPERATION CONDITIONS

The EUT tested system was configured as the statements of 2.4 Unless otherwise a special operating condition is specified in the follows during the testing.

6.1.5 TEST RESULTS

| | | | |
|---------------|--|---------------------|------------|
| EUT : | CDT-XX5370-00~09 | Model Name : | B0-9(5370) |
| Temperature : | 25 °C | Relative Humidity : | 60% |
| Pressure : | 1012 hPa | Test Voltage : | DC 5.0V |
| Test Mode : | TX b/g/n(20M,40M) Mode /CH01, CH06, CH11 | | |

| TX 802.11b Mode | | | | |
|----------------------------|-----------|-------------------------------------|------------------------------------|-------|
| Test Channe | Frequency | Maximum Peak Conducted Output Power | Maximum Conducted Output Power(AV) | LIMIT |
| | (MHz) | (dBm) | (dBm) | dBm |
| CH01 | 2412 | 12.79 | 9.77 | 30 |
| CH06 | 2437 | 12.38 | 9.78 | 30 |
| CH11 | 2462 | 12.57 | 9.52 | 30 |
| TX 802.11g Mode | | | | |
| CH01 | 2412 | 10.65 | 7.43 | 30 |
| CH06 | 2437 | 10.52 | 7.25 | 30 |
| CH11 | 2462 | 10.59 | 7.19 | 30 |
| TX 802.11n(20) Mode | | | | |
| CH01 | 2412 | 10.97 | 7.31 | 30 |
| CH06 | 2437 | 10.68 | 6.68 | 30 |
| CH11 | 2462 | 10.55 | 6.54 | 30 |
| TX 802.11n(40) Mode | | | | |
| CH03 | 2422 | 9.78 | 7.11 | 30 |
| CH06 | 2437 | 9.68 | 6.68 | 30 |
| CH09 | 2452 | 9.51 | 6.54 | 30 |

7. ANTENNA REQUIREMENT

7.1 STANDARD REQUIREMENT

15.203 requirement: For intentional device, according to 15.203: an intentional radiator shall be designed to ensure that no antenna other than that furnished by the responsible party shall be used with the device.

7.2 EUT ANTENNA

The EUT antenna is Integrated antenna. It comply with the standard requirement.

8. EUT TEST PHOTO

Radiated Measurement Photos

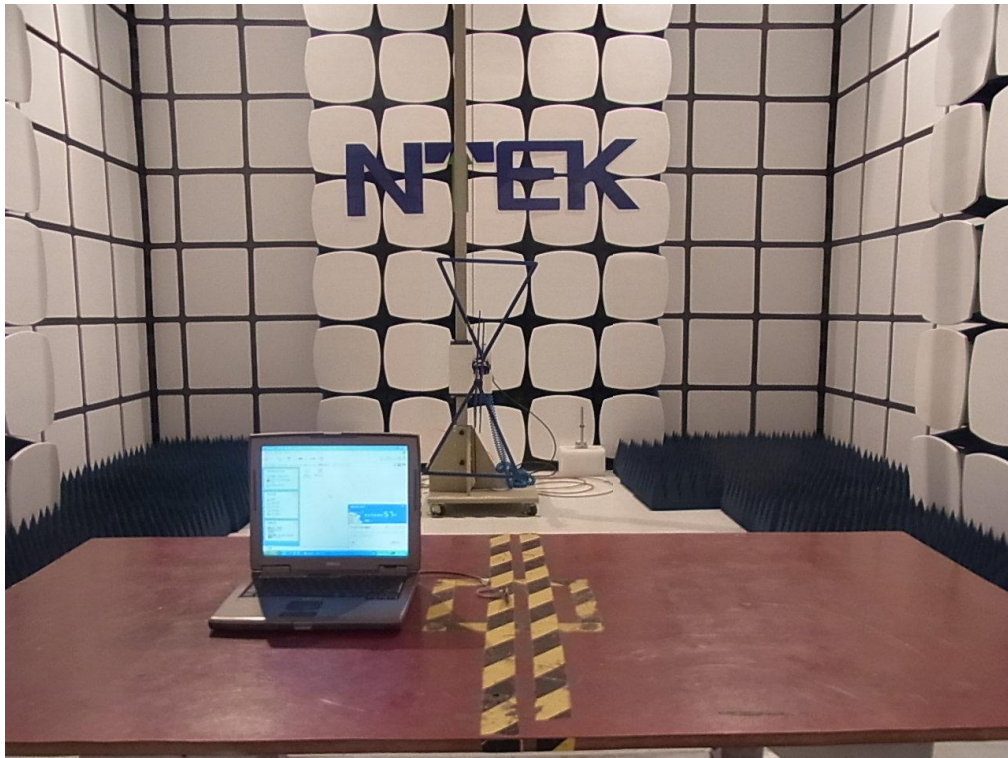
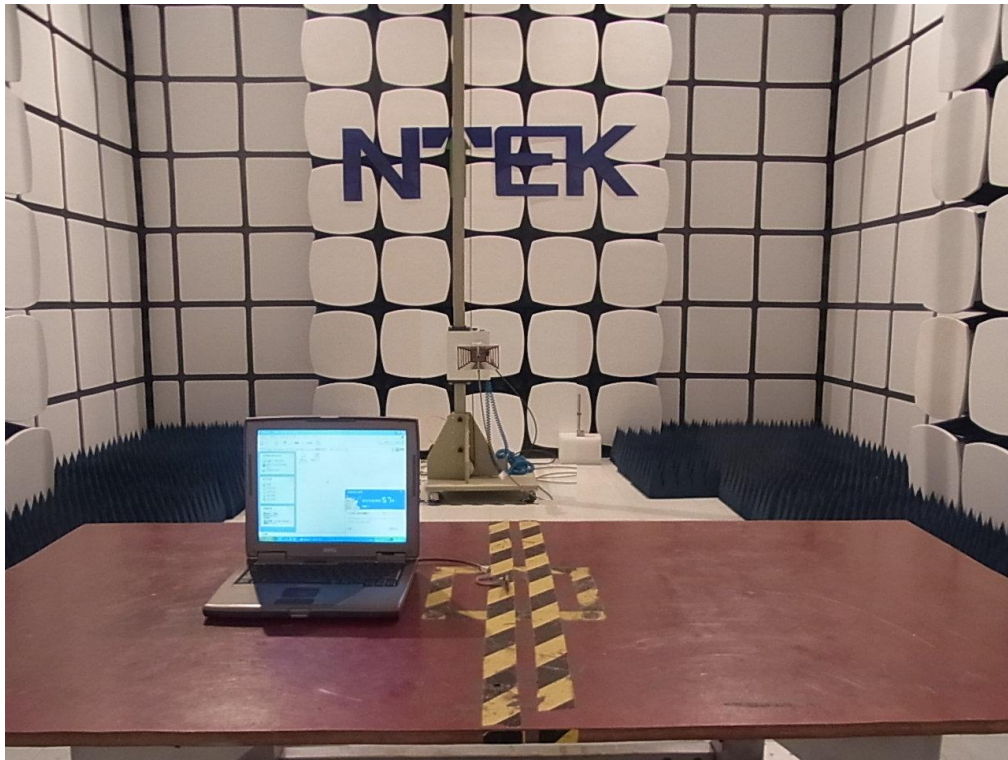

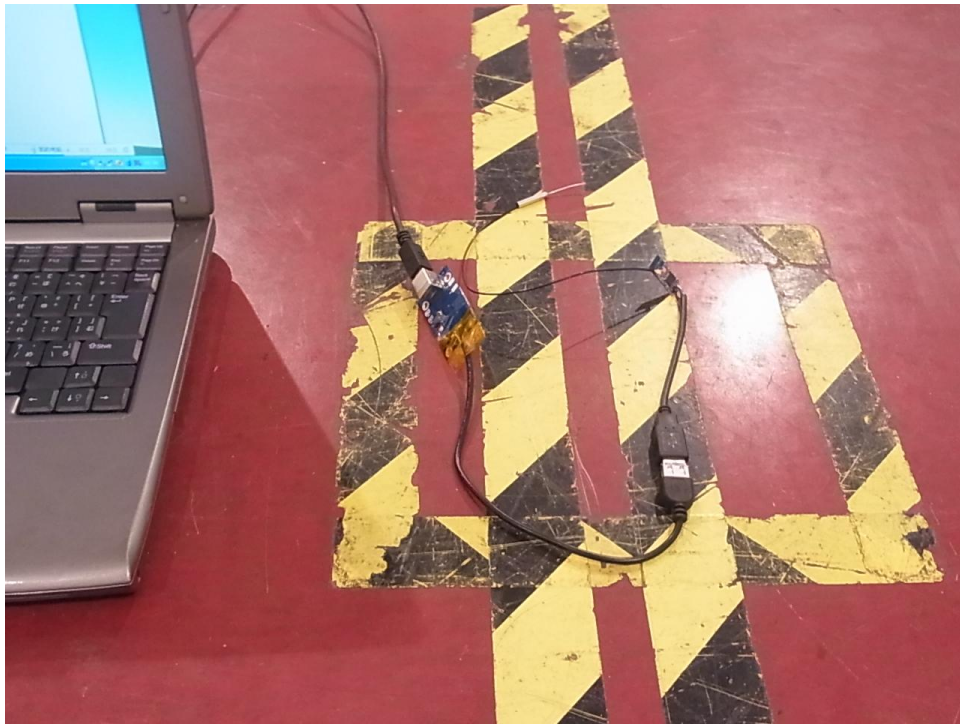

Conducted Measurement Photos

