



TEST REPORT NO: RU1139/6029  
COPY NO: -----  
ISSUE NO: 1  
FCC ID: Q639522A

**REPORT ON THE CERTIFICATION TESTING OF AN  
IRIDIUM SATELLITE LLC  
DAYTONA L-BAND TRANSCEIVER  
WITH RESPECT TO  
THE FCC RULES CFR 47, PART 25**

TEST DATE: 18<sup>th</sup> January 2005 – 21<sup>st</sup> January 2005

TESTED BY: ----- J CHARTERS  
APPROVED BY: ----- P GREEN  
PRODUCT MANAGER  
EMC  
DATE: 27<sup>th</sup> January 2005-----

Distribution:

- Copy Nos:
1. Cambridge Consultants Limited
  2. TCB: TRL Compliance Services Limited
  3. TRL EMC

THIS DOCUMENT MAY BE REPRODUCED ONLY IN ITS ENTIRETY AND WITHOUT CHANGE



## CONTENTS

	<b>PAGE</b>
CERTIFICATE OF CONFORMITY & COMPLIANCE	3
APPLICANT'S SUMMARY	4
EQUIPMENT TEST CONDITIONS	5
TESTS REQUIRED	5
TEST RESULTS – Transmitter	
RF Output Power - Conducted	6
Emissions Limitations - Conducted	7
Spurious Emissions - Conducted	8
Spurious Emissions - Radiated	9
Frequency Stability -Temperature	10
Frequency Stability -Voltage	11
	<b>ANNEX</b>
PHOTOGRAPHS	A
APPLICANT'S SUBMISSION OF DOCUMENTATION LIST	B
TEST EQUIPMENT LIST	C
TEST COMMANDS	D
DUTY CYCLE	E
EMISSIONS LIMITATIONS	F
TRANSMITTER SPURIOUS EMISSIONS – Conducted	G
TRANSMITTER SPURIOUS EMISSIONS – Radiated	H
FREQUENCY STABILITY – Temperature	I
FREQUENCY STABILITY – Voltage	J

**Notes:**

- |    |   |     |     |
|----|---|-----|-----|
| 1. | Component failure during test   | YES | [ ] |
|    |   | NO  | [X] |
| 2. | If Yes, details of failure:   |     |     |
| 3. | The facilities used for the testing of the product contain in this report are FCC Listed. |     |     |



**CERTIFICATE OF CONFORMITY & COMPLIANCE**

FCC IDENTITY: Q639522A  
PURPOSE OF TEST: Certification  
TEST SPECIFICATION: FCC Rules CFR 47, Part 25  
TEST RESULT: Compliant to Specification  
ITU EMISSIONS DESIGNATOR 41K7Q7W  
EQUIPMENT UNDER TEST: Daytona L-Band Transceiver  
EQUIPMENT TYPE: Satellite Communications Module  
MAXIMUM OUTPUT 40.11dBm, 10.3W, 10.11dBW  
ANTENNA TYPE: External TNC connector. For test purposes applicant declared a Fixed Mast Antenna with a gain of 2dBi  
CHANNEL SPACING: 41.667 kHz  
NUMBER OF CHANNELS: 252  
MODULATION TYPE: Q7W  
POWER SOURCE(s): +4.4 Vdc  
TEST DATE(s): 18<sup>th</sup> January 2005 – 21<sup>st</sup> January 2005  
ORDER No(s): EU2942  
APPLICANT: Iridium Satellite LLC  
ADDRESS: 6701 Democracy Blvd.  
Suite 500  
Bethesda  
United States of America  
MD 20817

TESTED BY: \_\_\_\_\_ J CHARTERS

APPROVED BY: \_\_\_\_\_ P GREEN  
PRODUCT  
MANAGER EMC

## APPLICANT'S SUMMARY

EQUIPMENT UNDER TEST (EUT): Daytona L-Band Transceiver

EQUIPMENT TYPE: Satellite Communications Module

PURPOSE OF TEST: Certification

TEST SPECIFICATION(S): FCC Rules CFR 47, Part 25

TEST RESULT: COMPLIANT Yes   
No

APPLICANT'S CATEGORY: MANUFACTURER   
IMPORTER   
DISTRIBUTOR   
TEST HOUSE   
AGENT

APPLICANT'S CONTACT PERSON(S): Mr C Geibel

E-mail address: Conrad.geibel@iridium.com

APPLICANT: Iridium Satellite LLC

ADDRESS: 6701 Democracy Blvd.  
Suite 500  
Bethesda  
United States of America  
MD 20817

TEL: +1 301 571 6277

FAX: +1 301 571 6250

MANUFACTURER: Iridium Satellite LLC

DEVELOPMENT AGENT Cambridge Consultants Limited

DEVELOPMENT AGENT S CONTACT PERSON(S): Mr P Williams

E-mail address: paul.williams@cambridgeconsultants.com

ADDRESS: Science Park  
Milton Road  
Cambridge  
CB4 4DW  
United Kingdom

TEL: +44 (0)1223 420024

FAX: +44 (0)1223 423373

EUT(S) COUNTRY OF ORIGIN: United States

TEST LABORATORY: TRL EMC

UKAS ACCREDITATION No: 0728

TEST DATE(S): 18<sup>th</sup> January 2005 – 21<sup>st</sup> January 2005

TEST REPORT No: RU1139/6029

**EQUIPMENT TEST / EXAMINATIONS REQUIRED**

1.	TEST/EXAMINATION	FCC Part 2	FCC Part 25	APPLICABILITY	RESULT
	RF Power Output	-	25.204 (a)	YES	PASS
	Emissions Limitations	-	25.202 (f)	YES	PASS
	Spurious Emissions at Antenna Terminals	2.1051	25.202 (f) 25.213	YES	PASS
	Protection of the Radio Navigation Satellite Service	-	25.216(c) 25.216(f)	YES	PASS
	Spurious Emissions Radiated	2.1053	25.202 (f) 25.213	YES	PASS
	Frequency Stability Temperature	2.1055	25.202 (d)	YES	PASS
	Frequency Stability Voltage	2.1055	25.202 (d)	YES	PASS

Note: The Daytona L-Band Transceiver is subject to FCC Part 25 & Part 2 for FCC Certification for units marketed within the United States. The above tests, as specified in FCC Part 2, with limits as defined in FCC Part 25 were performed on the Daytona L-Band Transceiver.

- 2. Product Use: Satellite Telephone and Data Communications
- 3. Emission Designator: 41k7Q7W
- 4. Temperatures: Ambient (Tnom) 20°C
- 5. Supply Voltages: Vnom +4.4 Vdc

Note: Vnom voltages are as stated above unless otherwise shown on the test report page

- 6. Equipment Category: Single channel   
Two channel   
Multi-channel
- 7. Channel spacing: Narrowband  41.667 kHz  
Wideband
- 8. Test Location: TRL Compliance Services  
Up Holland   
Long Green
- 9. Modifications made during test program: No modifications were performed.

## Product Description

The satellite communications module consists of an L-Band Transceiver (LBT) capable of simultaneous transmit and receive (duplex) operation covering the frequency range of 1616MHz to 1626.5MHz. The frequency accesses used for duplex channels are organised into sub-bands each of which contains eight frequency accesses. Each sub-band, therefore occupies 333.33 kHz (i.e.  $8 \times 41.667\text{kHz}$ ). Up to 30 sub-bands containing 240 frequency accesses may be used for duplex channels.

## Standard References

- 47 CFR 2            Code of Federal Regulations, Title 47, Part 2, "Frequency allocations and Radio Telemetry Matters;  
10-1-03 Edition    General Rules and Regulations"
  
- 47 CFR 25         Code of Federal Regulations, Title 47, Part 25, "Satellite Communications" Subpart C,  
10-1-03 Edition    "Technical Matters"
  
- C63.4-2003        American National Standards Institute (ANSI), "Methods of Measurement of Radio Noise Emissions  
from Low Voltage Electrical and Electronic Equipment in the Range 9 kHz to 40 GHz"

**COMPLIANCE TESTS**

**TRANSMITTER TESTS**

**RF OUTPUT POWER – CONDUCTED – PART 25.204 (a)**

Ambient temperature = 15.5°C  
 Relative humidity = 49%  
 Supply voltage = +4.4 Vdc  
 Channel number = See test results

Radio Laboratory

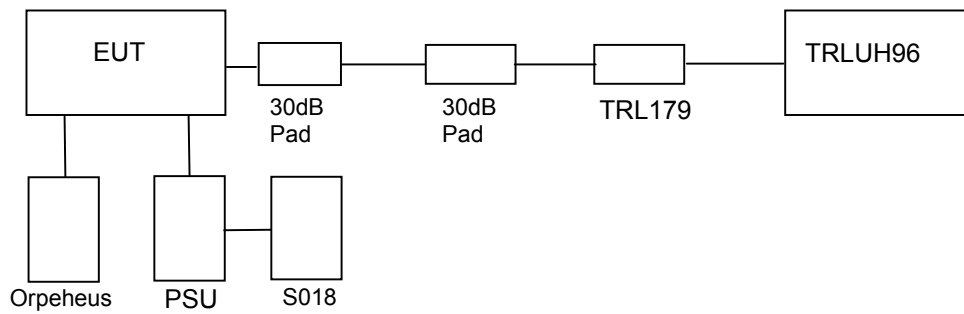

See Annex C for full list of test equipment

The test setup was as per the above diagram. The unit was tested on four channels. The unit was put into test mode and set to operate at maximum power and with a random modulating signal using the manual test command 27 XXX YY Z# (See Annex D for explanation of test command). The antenna gain, included in the table below, represents the highest gain of any antennas that are used with this system.

Frequency MHz	Attenuator and cable loss dB	Level at Power Meter dBm	Antenna Gain dB	Duty Cycle Factor dB (See Annex D)	Carrier power dBm	Carrier power dBw	Limit dBW
Channel 1	59.7	-31.99	2	10.4	40.11	10.11	40
Channel 75	59.7	-32.56	2	10.4	39.54	9.54	40
Channel 150	59.7	-33.31	2	10.4	38.79	8.79	40
Channel 240	59.7	-33.99	2	10.4	38.11	8.11	40

- Notes:
1. Duty Cycle Factor =  $10 \times \log(1/X)$  Where  $X = (T_{on} / T_{frame})$ . See Annex E for duty cycle plots
  2. Correction Factor for dBm to dBW = -30dB
  3. Antenna gain of 2dBi is the worst case gain over an isotropic antenna

## TRANSMITTER TESTS

### EMISSIONS LIMITATIONS – CONDUCTED – PART 25.202 (f)

Ambient temperature = 20°C  
 Relative humidity = 54%  
 Supply voltage = +4.4 Vdc

Radio Laboratory

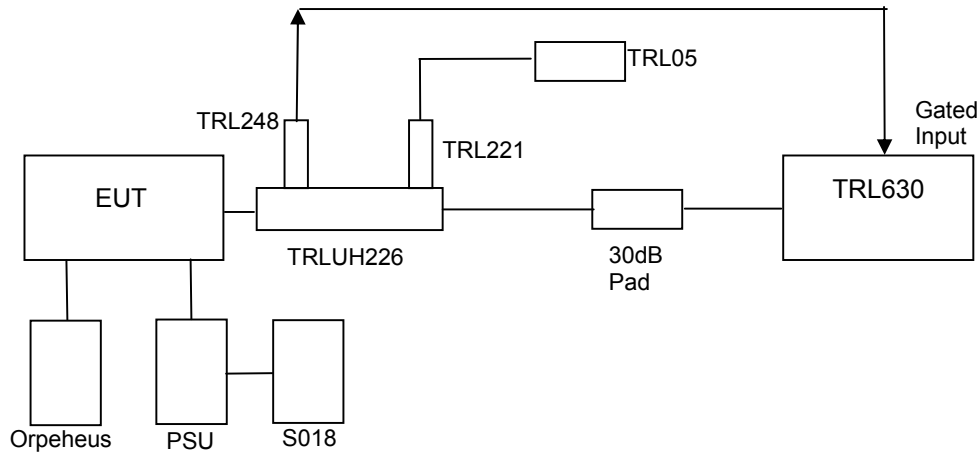

See Annex C for full list of test equipment

The test setup was as per the above diagram. The unit was tested on four channels. The unit was put into test mode and set to operate at maximum power and with a random modulating signal using the manual test command 27 XXX YY Z# (See Annex D for explanation of test command).

To enable an average measurement to be taken the gated input trigger of the spectrum analyser was used.

The Spurious limit is as follows:

On any frequency removed from the assigned frequency by the following percentage of the authorised bandwidth

±50%	-	100%	-25 dBc
±100%	-	250 %	-35 dBc
> ±250%			At least 43 + 10 log PdB

$$(10\log P_{\text{watts}}) - (43 + 10\log (P_{\text{watts}} * 1000)) = \text{LIMIT} = -13 \text{ dBm}$$

Where the Authorised Bandwidth = 41.667 kHz

The 3 kHz to 4 kHz bandwidth correction has been taken into account in the Ref level offset figure.

The Daytona L-Band Transceiver was found to comply with the limits

See plots in Annex F.



## TRANSMITTER TESTS

### SPURIOUS EMISSIONS – CONDUCTED – PART 25.202 (f) & 25.213

Ambient temperature = 26°C  
 Relative humidity = 62%  
 Supply voltage = +4.4 Vdc

Radio Laboratory

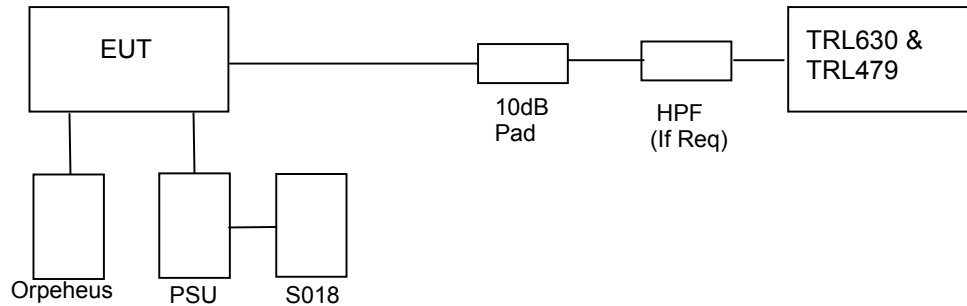

For measurements below band edge of 1610MHz use same test setup as per emissions limitations. For measurements above band edge of 1628.5MHz use the above test setup

See Annex C for full list of test equipment

The test setup was as per the above diagram. The unit was tested on four channels. The unit was put into test mode and set to operate at maximum power and with a random modulating signal using the manual test command 27 XXX YY Z# (See Annex D for explanation of test command).

The Spurious limit was calculated as follows:

On any frequency removed from the assigned frequency by more than 250% of the authorised bandwidth

At least  $43 + 10 \log(P)$  dB

$$(10 \log P_{\text{watts}}) - (43 + 10 \log (P_{\text{watts}} * 1000)) = \text{LIMIT} = -13 \text{ dBm}$$

## RESULTS

Frequency Range (MHz)	Ch N°	Freq. of Emission	Spectrum Analyser Level (dBm)	Attenuator & Cable Losses (dB)	Spurious Emission Level (dBm)	Limit dBm
30MHz – 1559MHz	No significant emissions within 10 dB's of the limit					-13
1559MHz – 1605MHz	1 240	1604.372 1604.398	-76.58 -78.38	31.3 31.3	-45.28 -47.08	-40
1605MHz – 1610MHz	1 240	1605.000 1605.000	-76.82 -78.31	31.3 31.3	-45.52 -47.01	-40 to 10
1628.5MHz – 16.3 GHz	No significant emissions within 10 dB's of the limit					-13

Notes :

1. Emissions Checked up to 10 times Fc
2. Reference level offset of Scan plots in Annex G already have approximate attenuator losses taken into account
3. Average measurement in a carrier on state were taken in the bands 1599MHz to 1605MHz and 1605MHz -1610MHz. All other scans were peak hold for worst case.
4. -40 to -10 Linearly interpolated in dBm Vs frequency offset.
5. Correction Factor for dBm to dBW = -30dB

The Daytona L-Band Transceiver was found to comply with the limits. See Annex G for plots

## TRANSMITTER TESTS

### SPURIOUS EMISSIONS – RADIATED – PART 25.202 (f) & 25.213

Ambient temperature = 18°C  
 Relative humidity = 55%  
 Conditions = OATS  
 Supply voltage = +4.4 Vdc  
 Supply Frequency = N/A

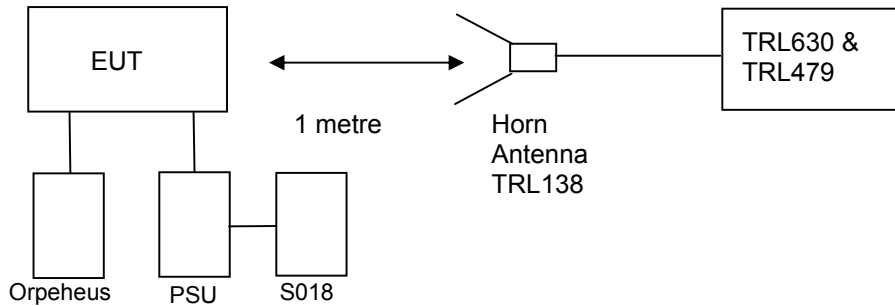

See Annex C for full list of test equipment

The test setup was as per the above diagram. The unit was tested on four channels. The unit was put into test mode and set to operate at maximum power and with a random modulating signal using the manual test command 27 XXX YY Z# (See Annex D for explanation of test command). The unit was mounted on a turntable and rotated through 360° to find the worst case emission.

The Spurious limit was calculated as follows:

On any frequency removed from the assigned frequency by more than 250% of the authorised bandwidth

At least  $43 + 10 \log P_{dB}$

$$(10 \log P_{\text{watts}}) - (43 + 10 \log (P_{\text{watts}} * 1000)) = \text{LIMIT} = -13 \text{ dBm}$$

## RESULTS

Frequency Range (MHz)	Ch N°	Freq. of Emission	Spectrum Analyser Level (dBm)	Attenuator & Cable Losses (dB)	Spurious Emission Level (dBm)	Limit dBm
30MHz – 1559MHz		No significant emissions within 10 dB's of the limit				-13
1559MHz – 1605MHz		No significant emissions within 10 dB's of the limit				-40
1605MHz – 1610MHz		No significant emissions within 10 dB's of the limit				-40 to 10
1628.5MHz – 16.3 GHz		No significant emissions within 10 dB's of the limit				-13

- Notes :
1. Emissions Checked up to 10 times Fc
  2. Scan plots of channels 1 & 240 with receive antenna in vertical polarization in annex H.
  3. The unit was mounted on a turntable and rotated through 360° and in 3 orthogonal planes to find the worst case emission.
  4. -40 to -10 Linearly interpolated in dBm Vs frequency offset.
  5. Correction Factor for dBm to dBW = -30dB

The Daytona L-Band Transceiver was found to comply with the limits. See annex H for plots

## TRANSMITTER TESTS

### FREQUENCY STABILITY – CONDUCTED – TEMPERATURE – PART 25.202 (d)

Ambient temperature = 28°C  
 Relative humidity = 49%  
 Supply voltage = +4.4 Vdc

Radio Laboratory

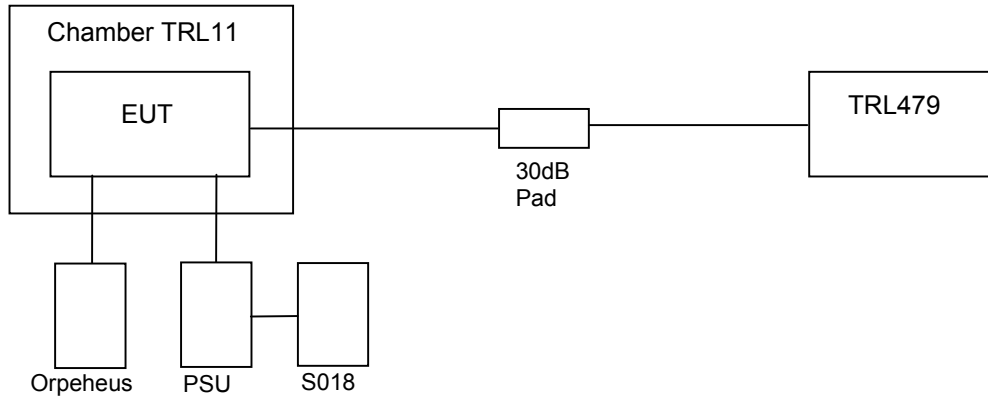

See Annex C for full list of test equipment

The test setup was as per the above diagram. The unit was tested on four channels. The unit was put into test mode and set to operate at maximum power and with a random modulating signal using test commands sent from a PC via the MAMBO Box that were equivalent to the manual test command 27 XXX YY Z# (See Annex D for explanation of test command). The Analyser was set to max hold

## RESULTS

TEMP °C	Frequency (MHz)			
	Channel 1	Channel 75	Channel 150	Channel 240
+60	1616.0282	1619.0997	1622.2267	1625.9750
+50	1616.0160	1619.1006	1622.2250	1625.9746
+40	1616.0172	1619.0996	1622.2264	1625.9758
+30	1616.0186	1619.1010	1622.2262	1625.9764
+20	1616.0192	1619.1010	1622.2280	1625.9756
+10	1616.0186	1619.1012	1622.2264	1625.9760
0	1616.0178	1619.1006	1622.2268	1625.9768
-10	1616.0172	1619.1014	1622.2270	1625.9758
-20	1616.0174	1619.1018	1622.2258	1625.9756
-30	1616.0164	1619.1008	1622.2186	1625.9744

Notes: 1.Limit  $\pm 10$ ppm (See Annex I for plots verses limit)

The Daytona L-Band Transceiver was found to comply with the limits

**TRANSMITTER TESTS**

**FREQUENCY STABILITY – CONDUCTED – VOLTAGE – PART 25.202 (d)**

Ambient temperature = 24°C Radio Laboratory  
 Relative humidity = 41%  
 Supply voltage = +4.4 Vdc

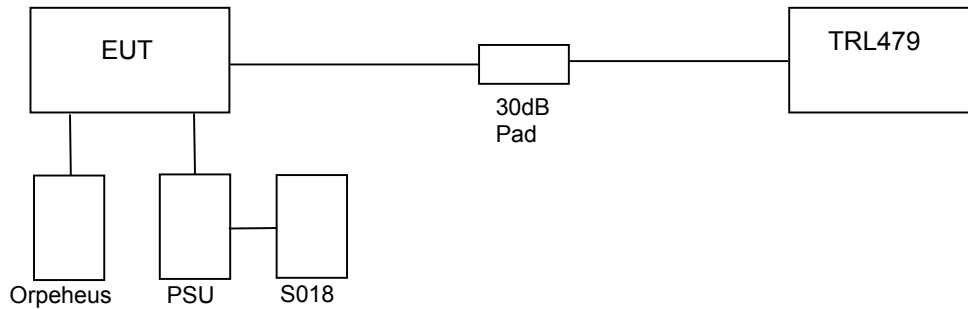

See Annex C for full list of test equipment

The test setup was as per the above diagram. The unit was tested on four channels .The unit was put into test mode and set to operate at maximum power and with a random modulating signal using the manual test command 27 XXX YY Z# (See Annex D for explanation of test command). The Analyser was set to max hold

**RESULTS**

VOLTAGE	Frequency (MHz)			
	Channel 1	Channel 75	Channel 150	Channel 240
85	1616.0246	1619.1010	1622.2270	1625.9774
90	1616.0190	1619.1012	1622.2270	1625.9760
95	1616.0176	1619.1018	1622.2252	1625.9762
100	1616.0182	1619.1010	1622.2262	1625.9766
105	1616.0184	1619.1012	1622.2262	1625.9756
110	1616.0174	1619.1014	1622.2264	1625.9756
115	1616.0188	1619.1012	1622.2258	1625.9758

Notes: 1.Limit ± 10ppm (See Annex J for plots verses limit)

The Daytona L-Band Transceiver was found to comply with the limits

**ANNEX A**  
**PHOTOGRAPHS**

PHOTOGRAPH 1.

RADIATED TEST SETUP

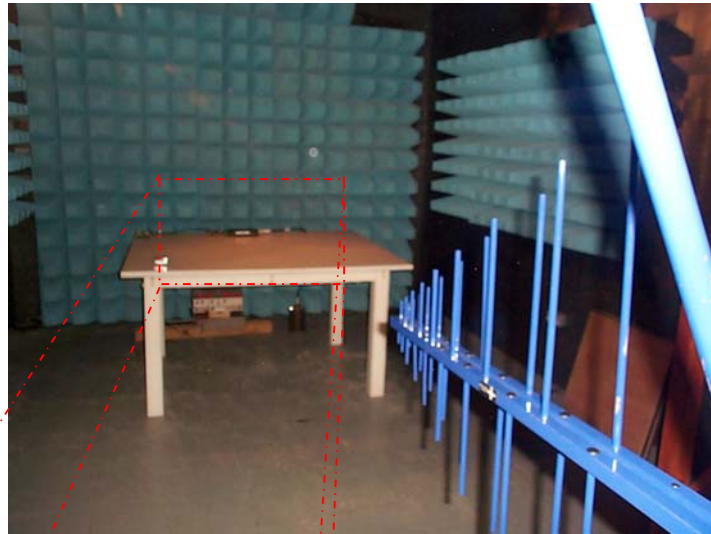

PHOTOGRAPH 2.

CONDUCTED TEST SETUP

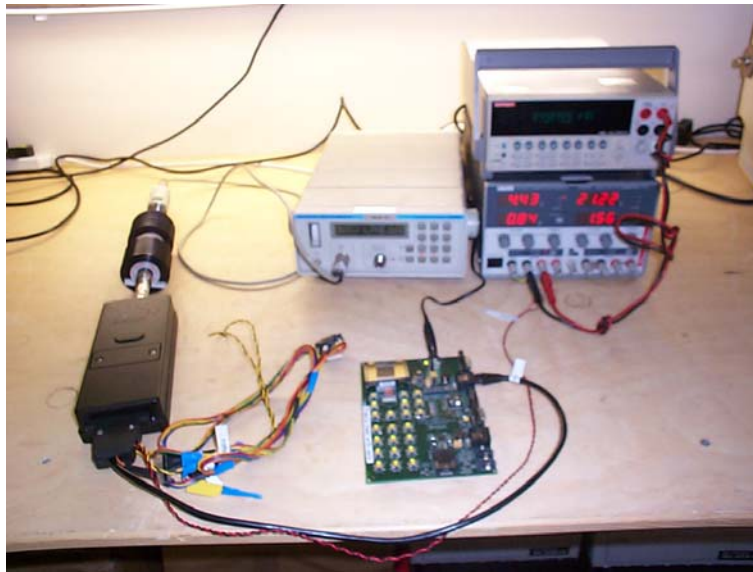

**ANNEX B**  
**APPLICANT'S SUBMISSION OF DOCUMENTATION LIST**



### APPLICANT'S SUBMISSION OF DOCUMENTATION LIST

a.	TCB	-	APPLICATION	<input checked="" type="checkbox"/>
		-	FEE	<input checked="" type="checkbox"/>
b.	AGENT'S LETTER OF AUTHORISATION	-		<input checked="" type="checkbox"/>
c.	MODEL(s) vs IDENTITY	-		<input type="checkbox"/>
d.	ALTERNATIVE TRADE NAME DECLARATION(s)	-		<input type="checkbox"/>
e.	LABELLING	-	PHOTOGRAPHS	<input type="checkbox"/>
		-	DECLARATION	<input type="checkbox"/>
		-	DRAWINGS	<input type="checkbox"/>
f.	TECHNICAL DESCRIPTION	-		<input checked="" type="checkbox"/>
g.	BLOCK DIAGRAMS	-	Tx	<input checked="" type="checkbox"/>
		-	Rx	<input type="checkbox"/>
		-	PSU	<input type="checkbox"/>
		-	AUX	<input type="checkbox"/>
h.	CIRCUIT DIAGRAMS	-	Tx	<input type="checkbox"/>
		-	Rx	<input type="checkbox"/>
		-	PSU	<input type="checkbox"/>
		-	AUX	<input type="checkbox"/>
i.	COMPONENT LOCATION	-	Tx	<input type="checkbox"/>
		-	Rx	<input type="checkbox"/>
		-	PSU	<input type="checkbox"/>
		-	AUX	<input type="checkbox"/>
j.	PCB TRACK LAYOUT	-	Tx	<input type="checkbox"/>
		-	Rx	<input type="checkbox"/>
		-	PSU	<input type="checkbox"/>
		-	AUX	<input type="checkbox"/>
k.	BILL OF MATERIALS	-	Tx	<input type="checkbox"/>
		-	Rx	<input type="checkbox"/>
		-	PSU	<input type="checkbox"/>
		-	AUX	<input type="checkbox"/>
l.	USER INSTALLATION / OPERATING INSTRUCTIONS	-		<input checked="" type="checkbox"/>

**ANNEX C**  
**TEST EQUIPMENT LIST**

TYPE OF EQUIPMENT	MAKER/SUPPLIER	MODEL No	SERIAL No	TRL No
SPECTRUM ANALYSER	R & S	ESIB 7	100182	630
SPECTRUM ANALYSER	ANRITSU	MS2665C	MT26089	479
PSU	MANSON	EP-603	60316619	149
PSU	THURLBY THANDAR	PL320QMD	N/A	N/A
RF DIODE	SUHNER	H7	1001.17.A	248
HORN	EMCO	3115	9010-3580	138
HORN	EMCO	3115	9010-3581	139
BIDIRECTIONAL COUPLER	NARDA	3022	72622	UH226
CABLE	ROSENBERGER	MICRO COAX	N/A	280
ENVIRONMENTAL CHAMBER(TEMP)	SHARTREE	TCC125-815P	CS 203	11
POWER METER	MARCONI	6960B	236997010	UH96
POWER SENSOR	MARCONI	6920	1227	179
LOOP ANTENNA 9kHz - 30MHz	R & S	HFH2	881058 - 53	07
MULTIMETER	KEITHLEY	2000	0588183	S018
LOAD	SUHNER	65 BNC-50-0-1	N/A	05
20dB ATTENUATOR	BIRD	8340-200-N	MFC 70998	221
30 dB ATTENUATOR	NARDA	776C-30	619	N/A
30 dB ATTENUATOR	NARDA	776C-30	577	N/A
EXTERNAL KEYPAD	CCL	ORPHEUS	C7032-011a/V1	N/A
HIGH PASS FILTER	AFL	N/A	N/A	N/A

**ANNEX D**  
**TEST COMMANDS**

## TEST COMMANDS

Command Function	Keypad Sequence
Enter Manual Test Mode	Press and Hold # Key for more than 3 seconds
Exit Manual Test Mode	01#
Turn on transmission with maximum power enabled and with random modulation	27 xxx yy z# xxx = Channel Number yy = power setp z = Modulation
<u>Example 1</u> Channel number 001 (Min frequency), power level 0 (Max) Modulation set to random data (z = 1, z = 0 is a tone)	27 001 00 1#
<u>Example 2</u> Channel number 240 (Max frequency), power level 8 (Min) Modulation set to random data (z = 1, z = 0 is a tone)	27 240 1#
Turn off transmission with maximum power enabled and with random modulation	27#

Notes: To enter test mode a test sim card is required.

**ANNEX E**  
**DUTY CYCLE**

# Duty Cycle Plots

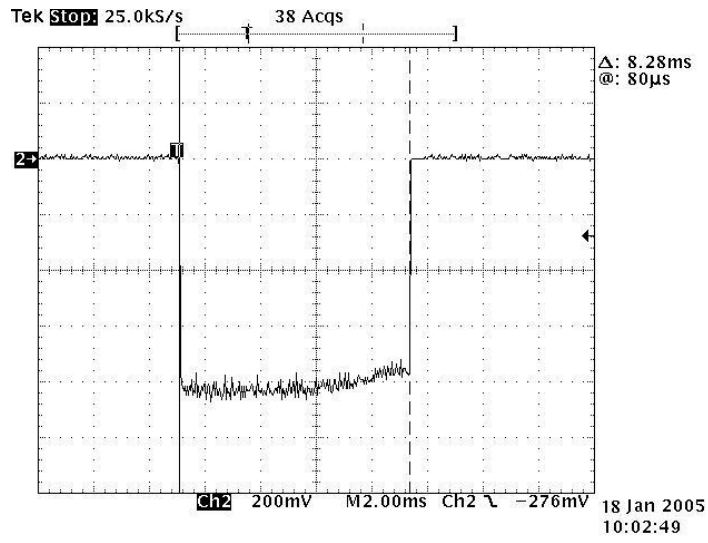

$$T_{on} = 8.28mS$$

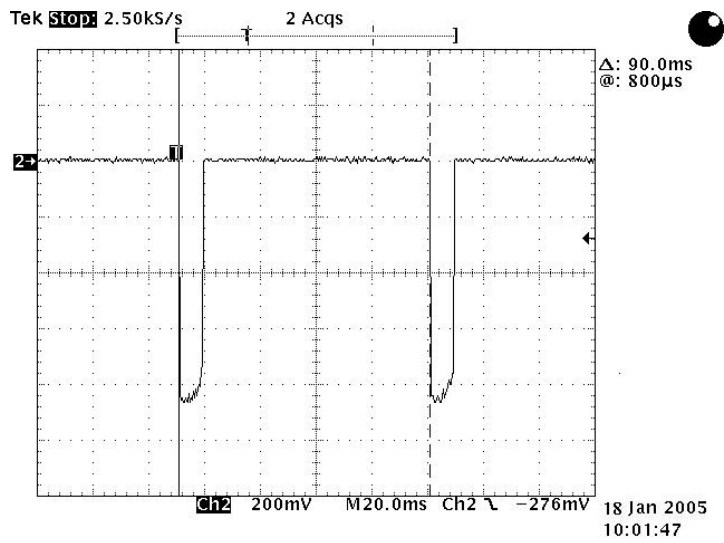

$$T_{frame} = 90mS$$

**ANNEX F**  
**EMISSIONS LIMITATIONS**



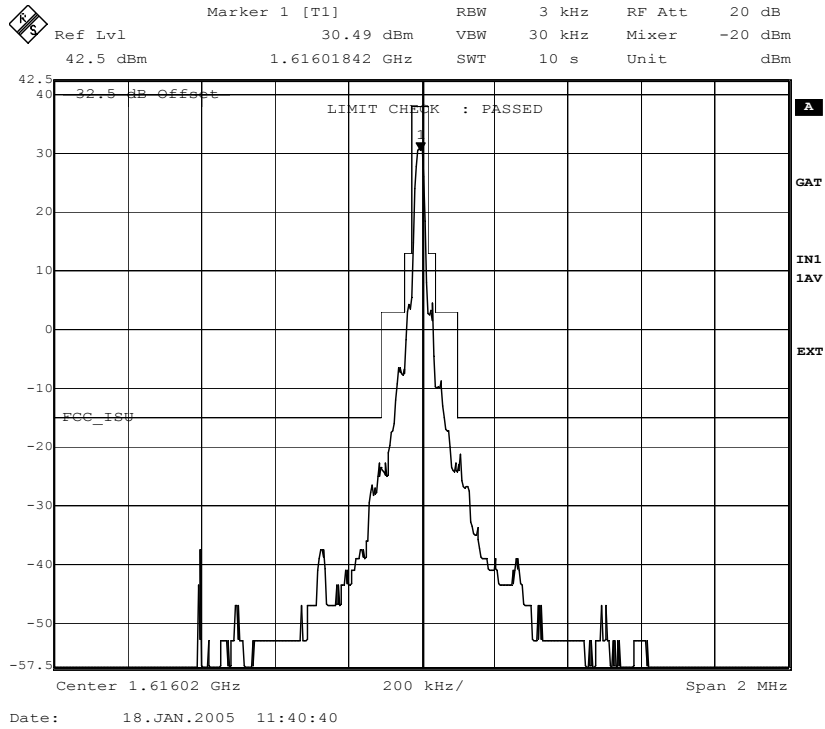

Channel 1

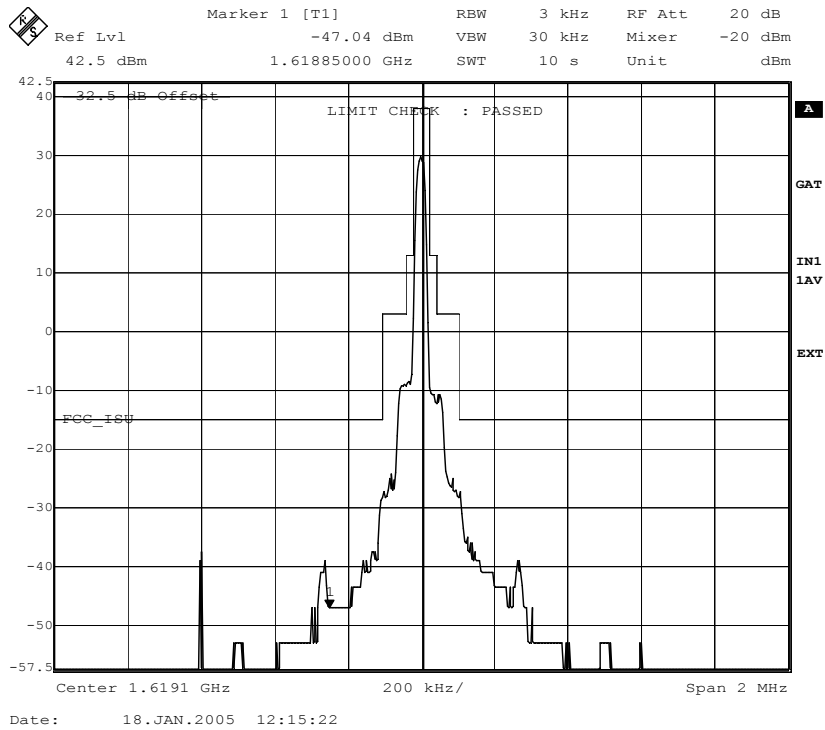

Channel 75

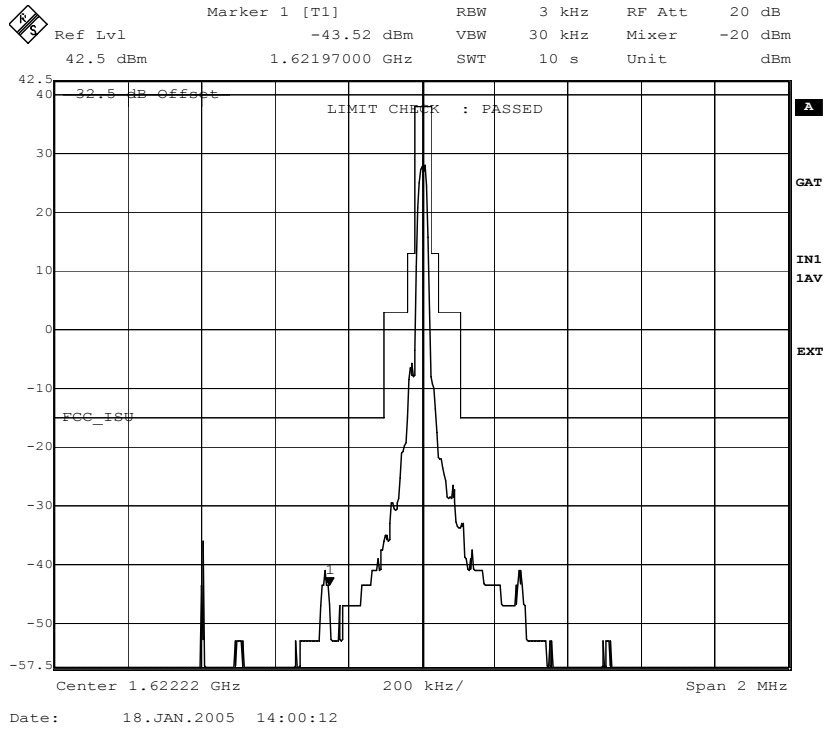

Channel 150

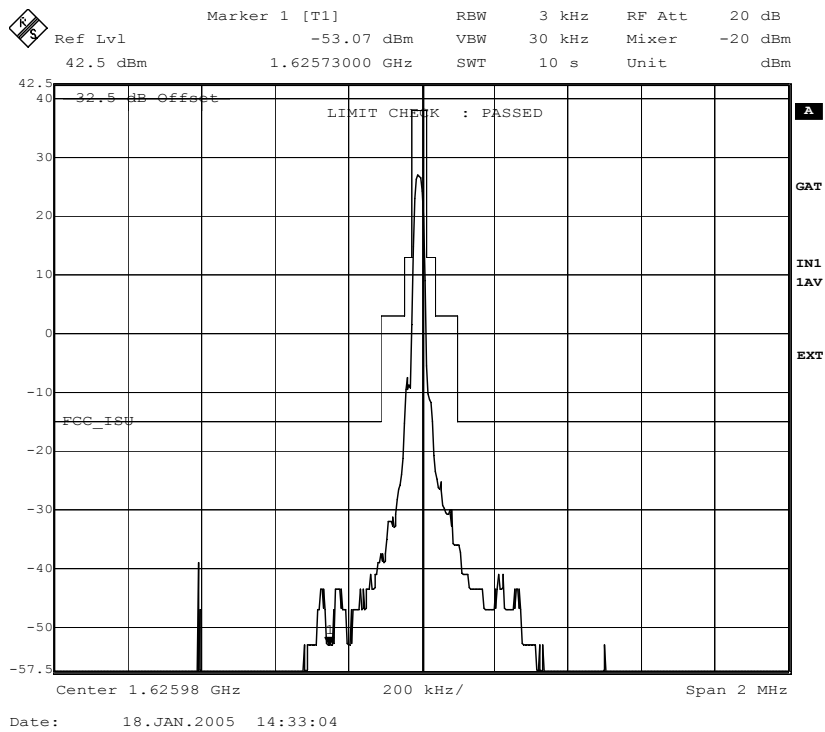

Channel 240

**ANNEX G**  
**TRANSMITTER SPURIOUS EMISSIONS - Conducted**

TRANSMITTER SPURIOUS EMISSIONS – Conducted

Channel 1

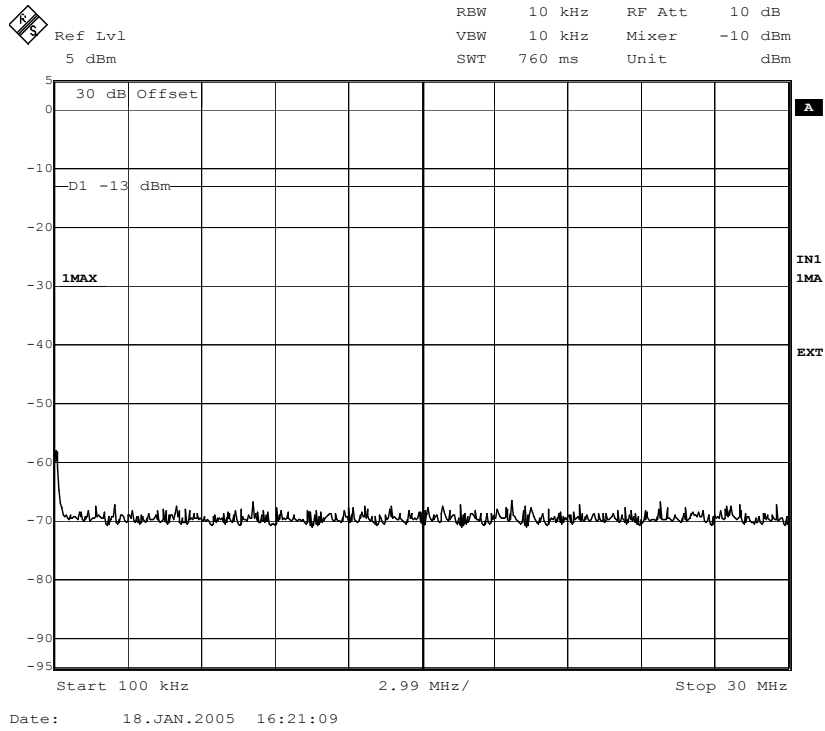

100 kHz – 30MHz

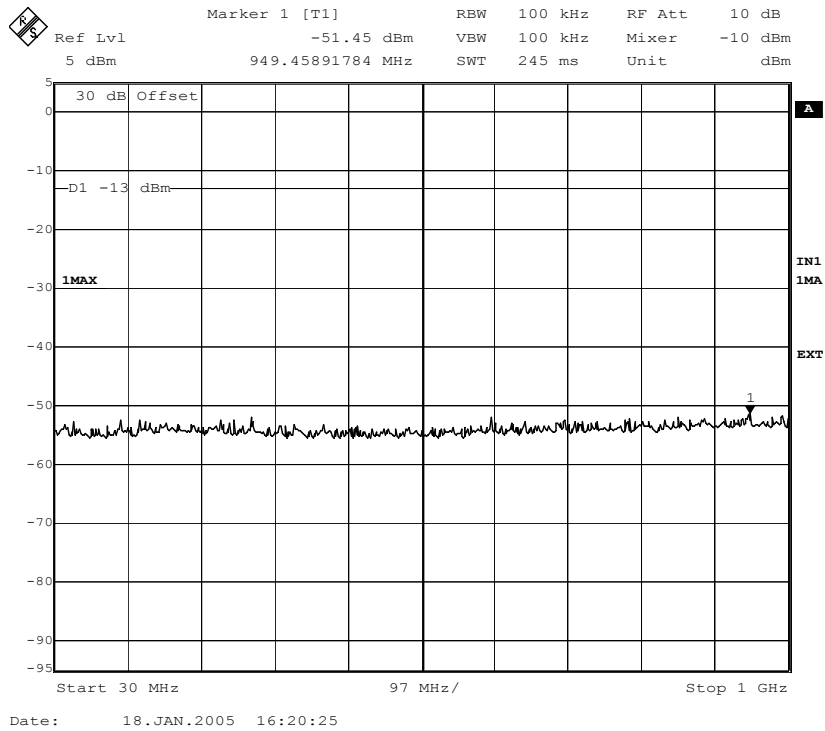

30MHz – 1000MHz

RU1074/4830

TRANSMITTER SPURIOUS EMISSIONS – Conducted

Channel 1

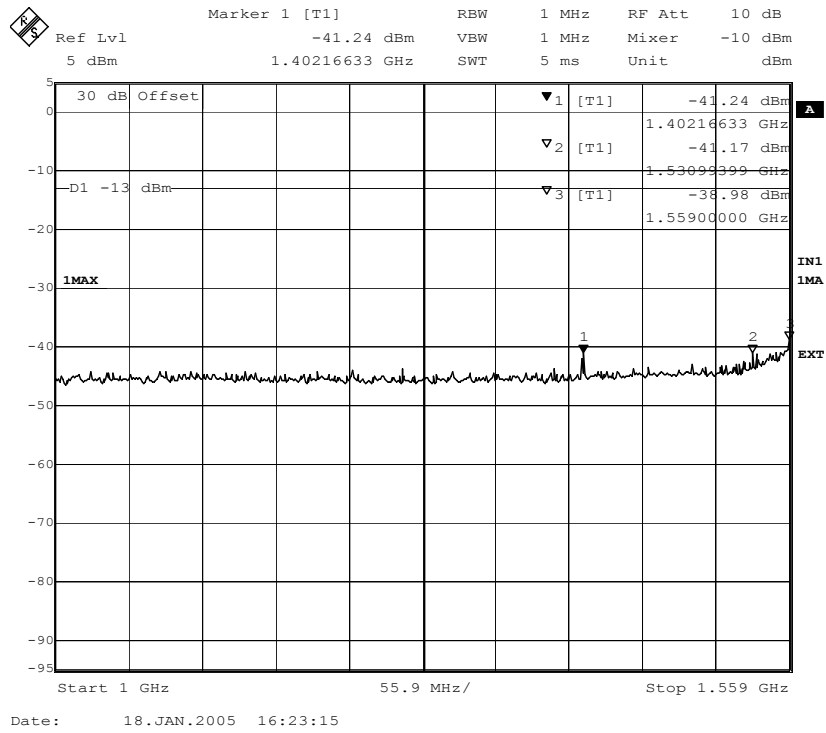

1000MHz – 1559MHz

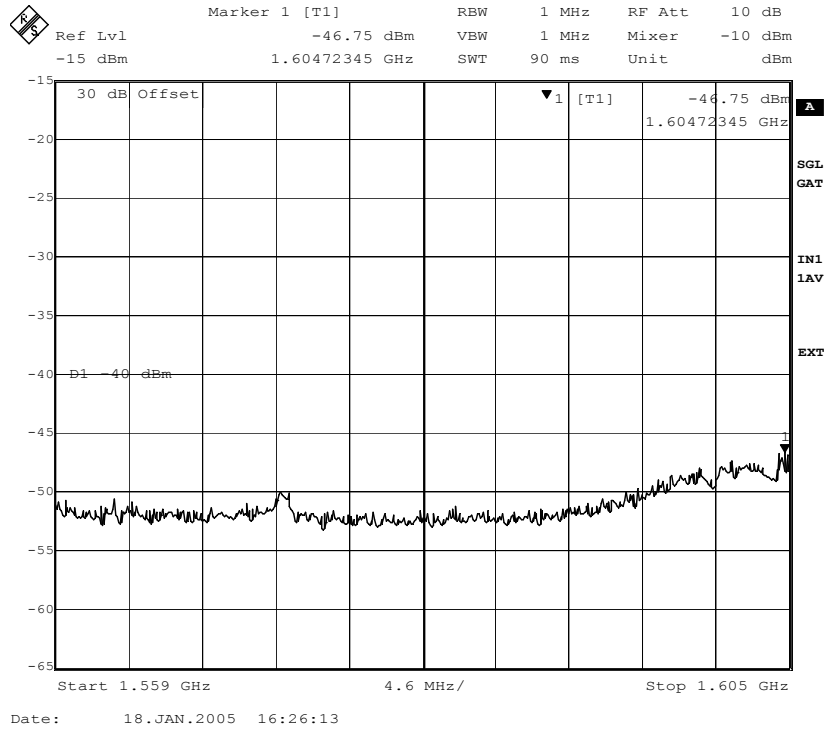

1559MHz – 1605MHz

RU1074/4830

TRANSMITTER SPURIOUS EMISSIONS – Conducted

Channel 1

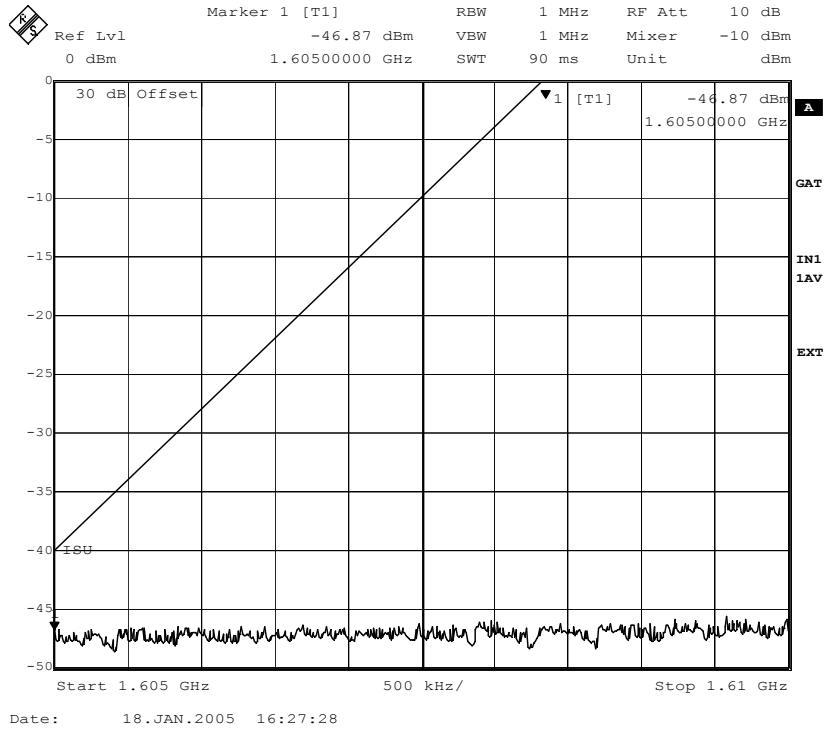

1605MHz – 1610MHz

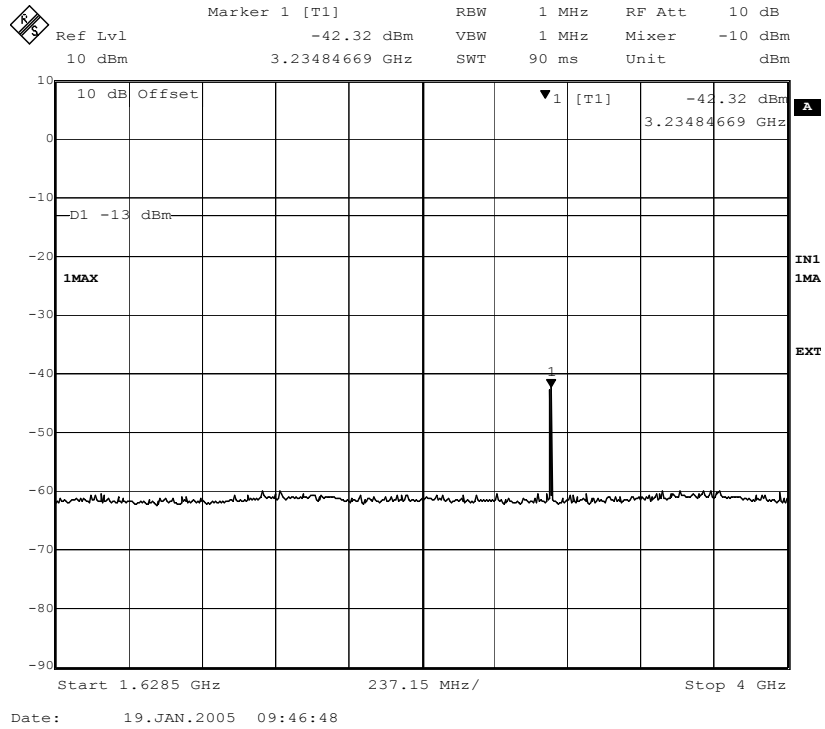

1628.5MHz – 4000MHz

RU1074/4830

TRANSMITTER SPURIOUS EMISSIONS – Conducted

Channel 1

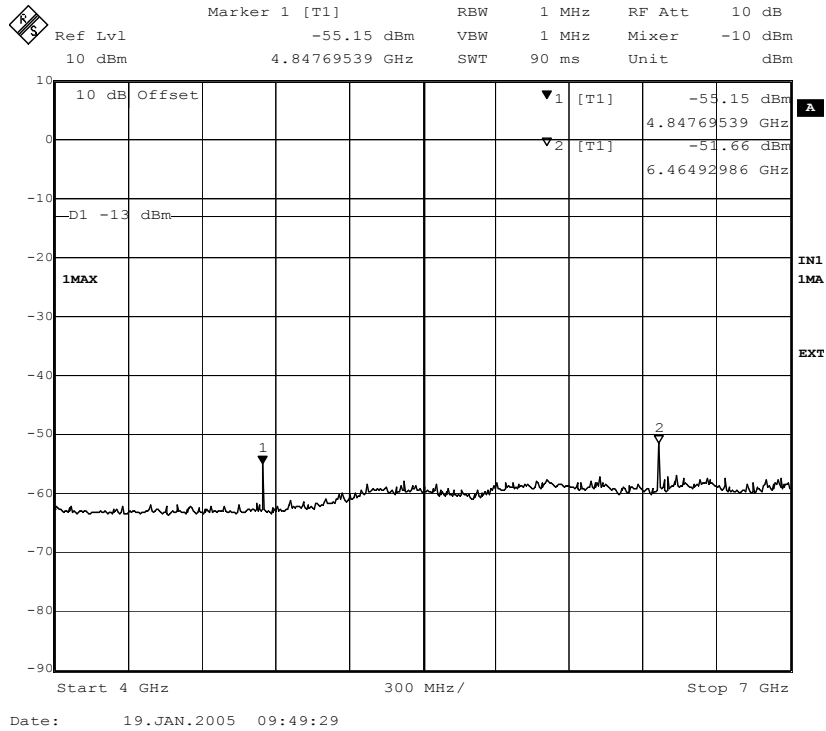

4GHz – 7GHz

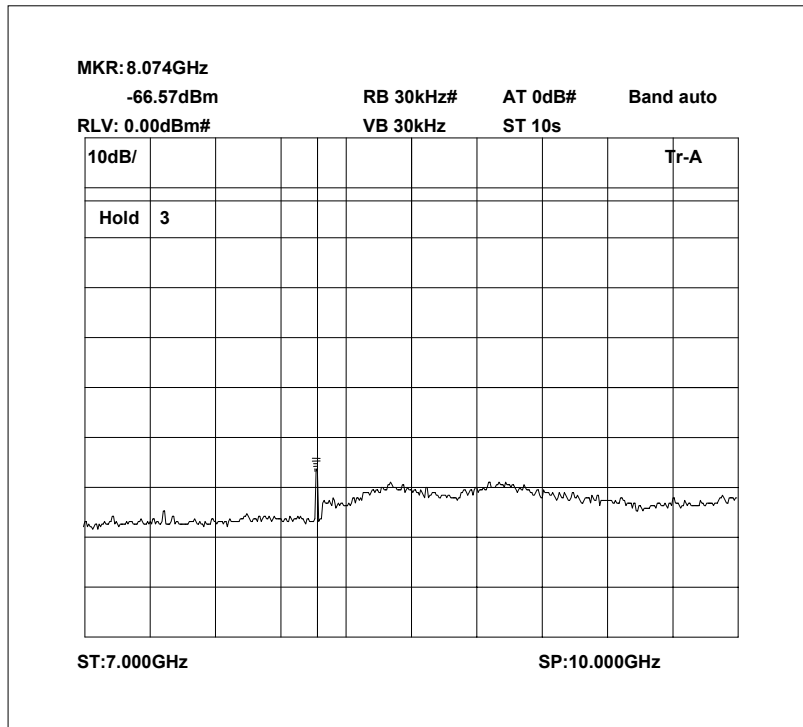

7GHz – 10GHz

RU1074/4830

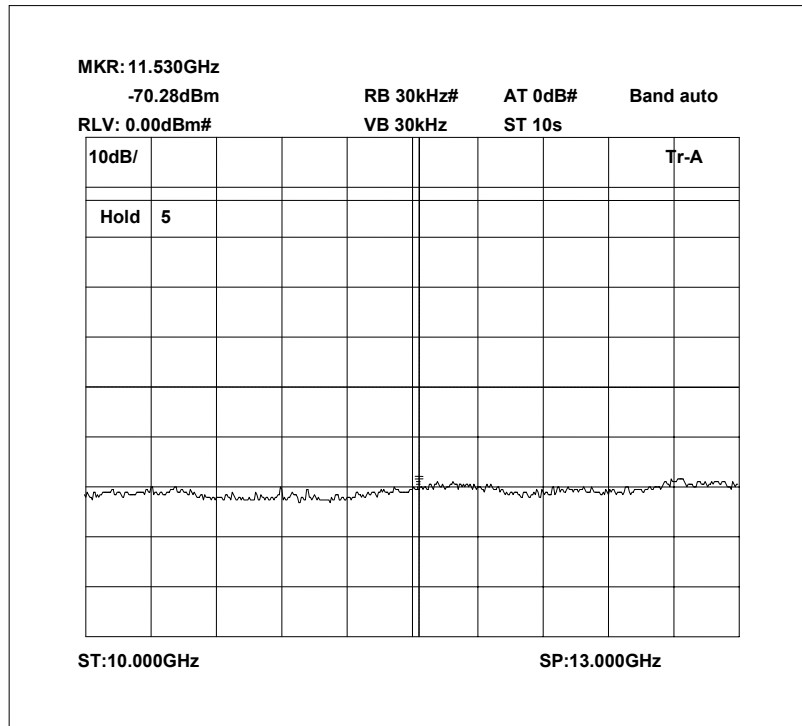

10GHz – 13GHz

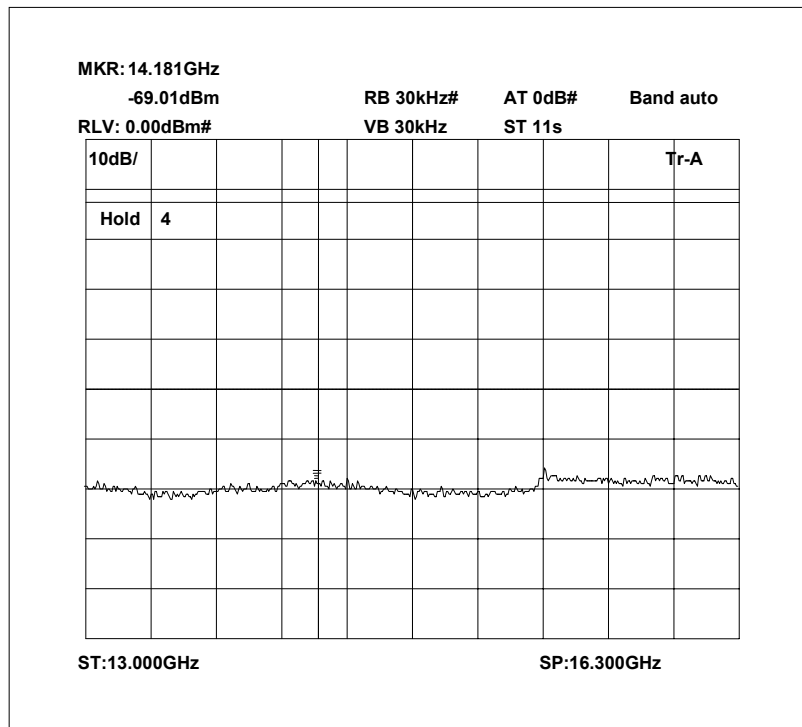

13GHz – 16.3GHz



TRANSMITTER SPURIOUS EMISSIONS – Conducted

Channel 240

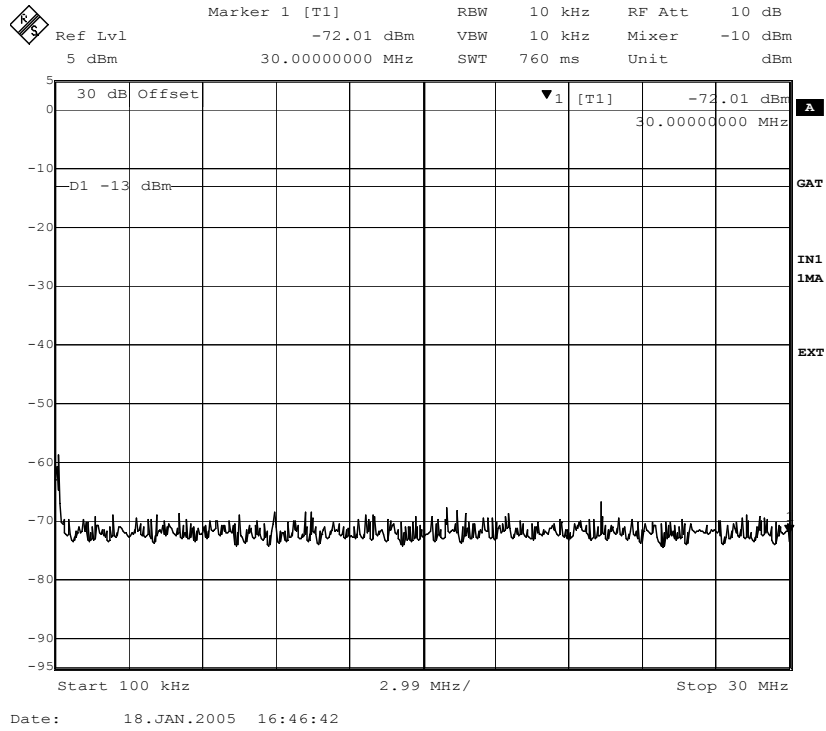

100 kHz – 30MHz

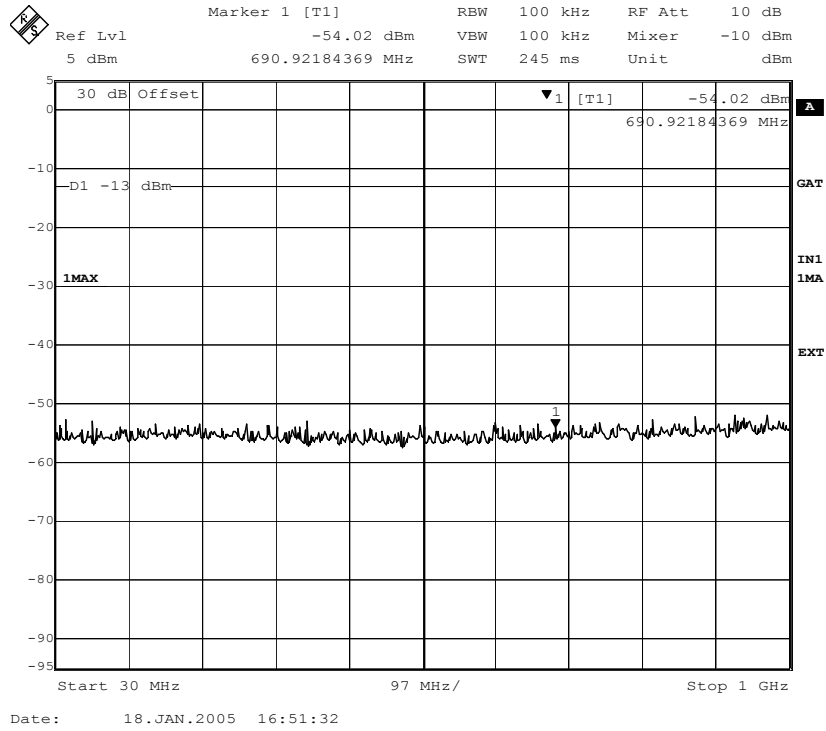

30MHz – 1000MHz

RU1074/4830

TRANSMITTER SPURIOUS EMISSIONS – Conducted

Channel 240

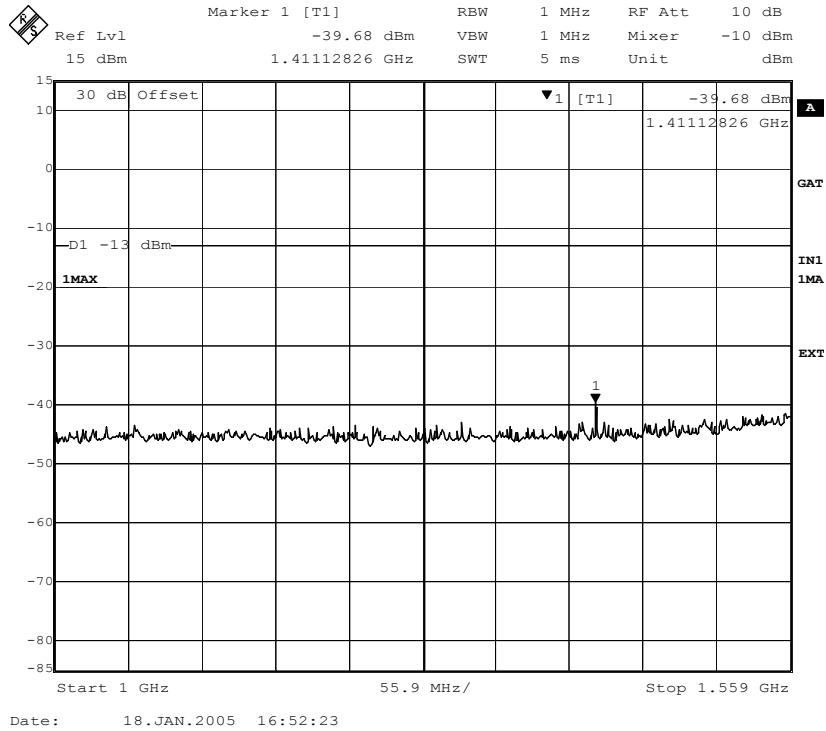

1000MHz – 1559MHz

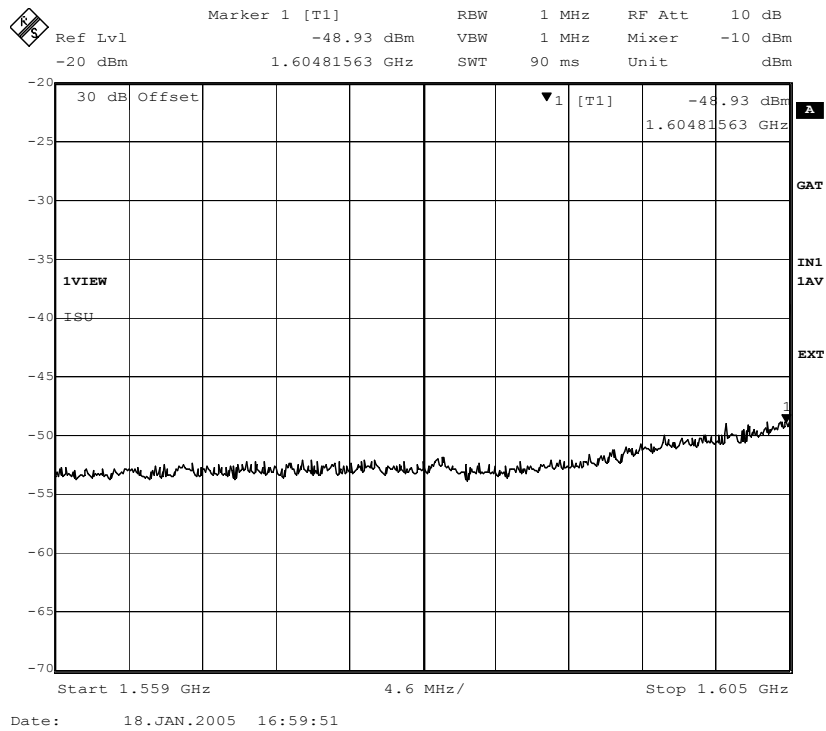

1559MHz – 1605MHz

RU1074/4830

TRANSMITTER SPURIOUS EMISSIONS – Conducted

Channel 240

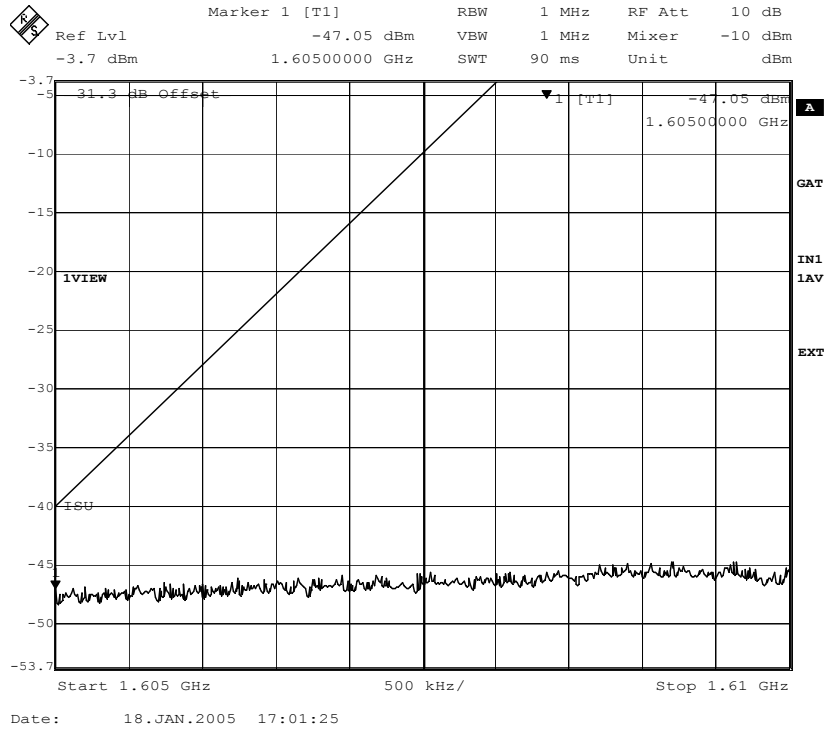

1605MHz – 1610MHz

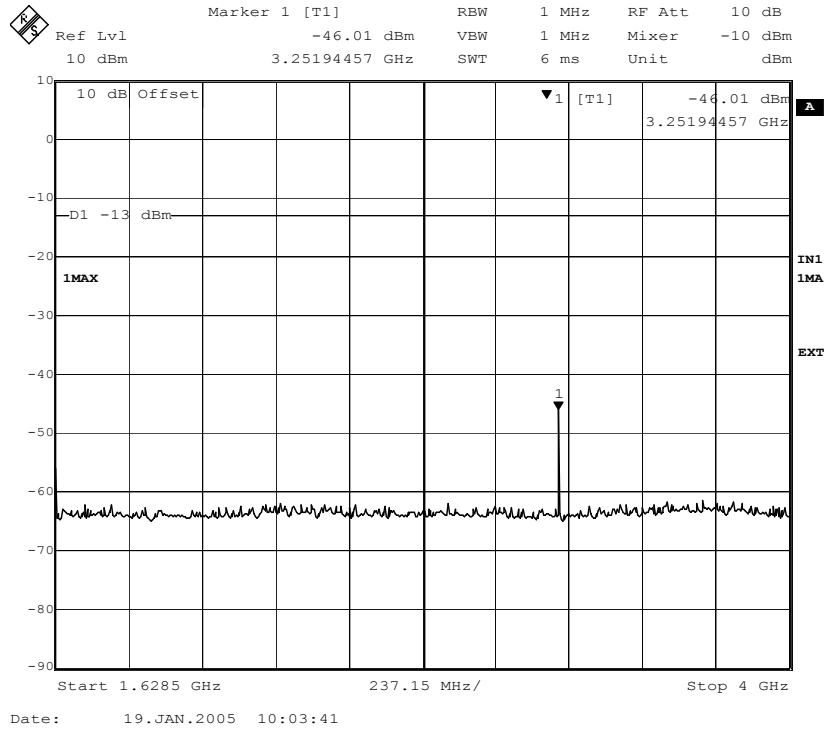

1628.5MHz – 4000MHz

RU1074/4830

TRANSMITTER SPURIOUS EMISSIONS – Conducted

Channel 240

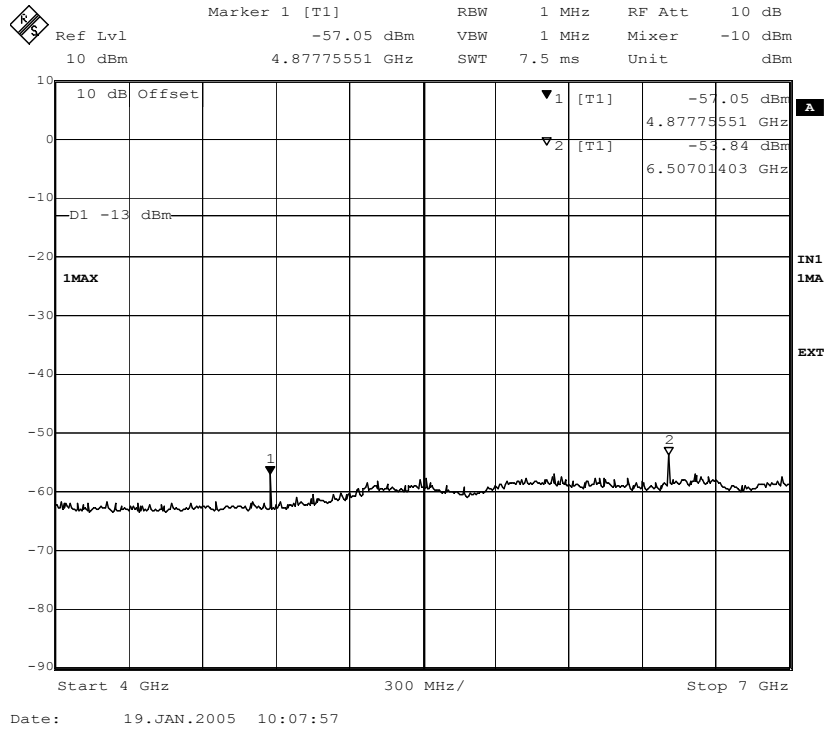

4GHz – 7GHz

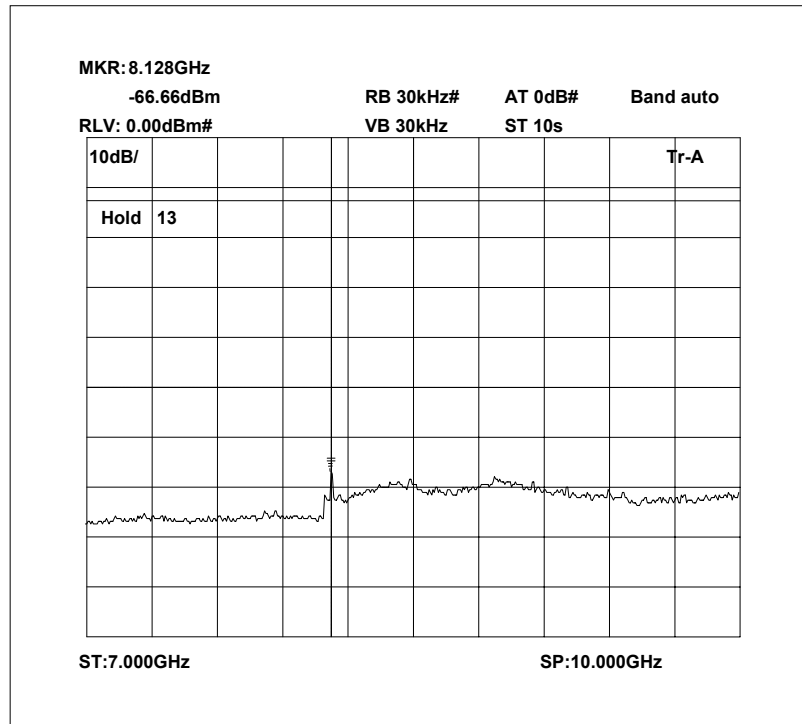

7GHz – 10GHz

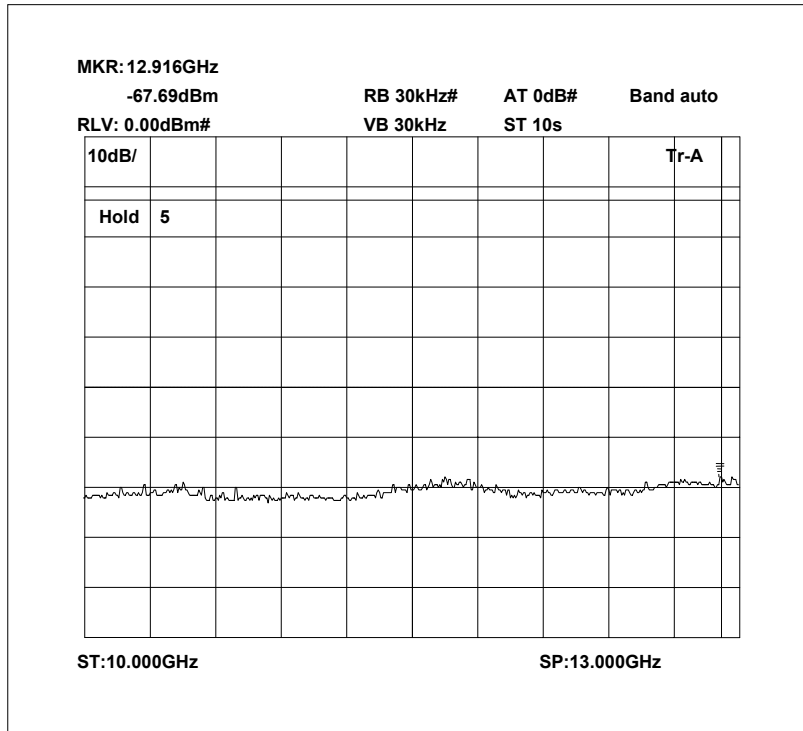

10GHz – 13GHz

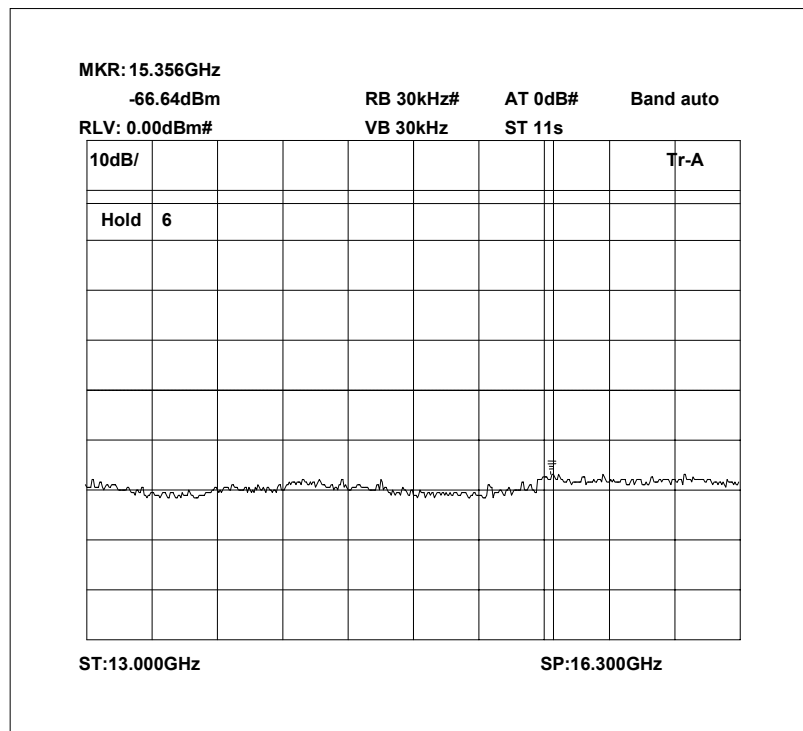

13GHz – 16.3GHz

**ANNEX H**

**TRANSMITTER SPURIOUS EMISSIONS - Radiated**

TRANSMITTER SPURIOUS EMISSIONS – Radiated

Channel 1

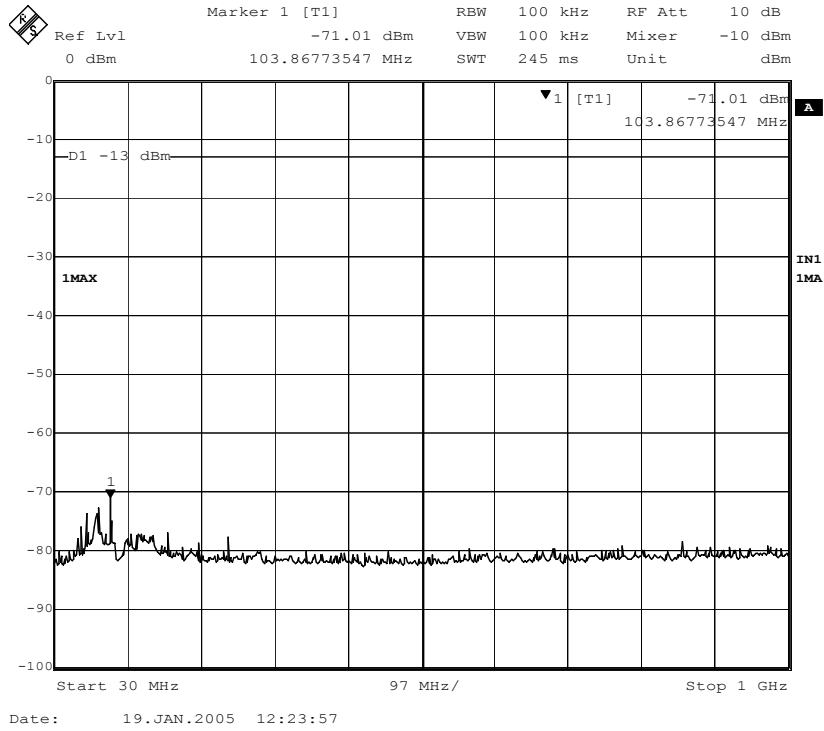

30MHz – 1000MHz

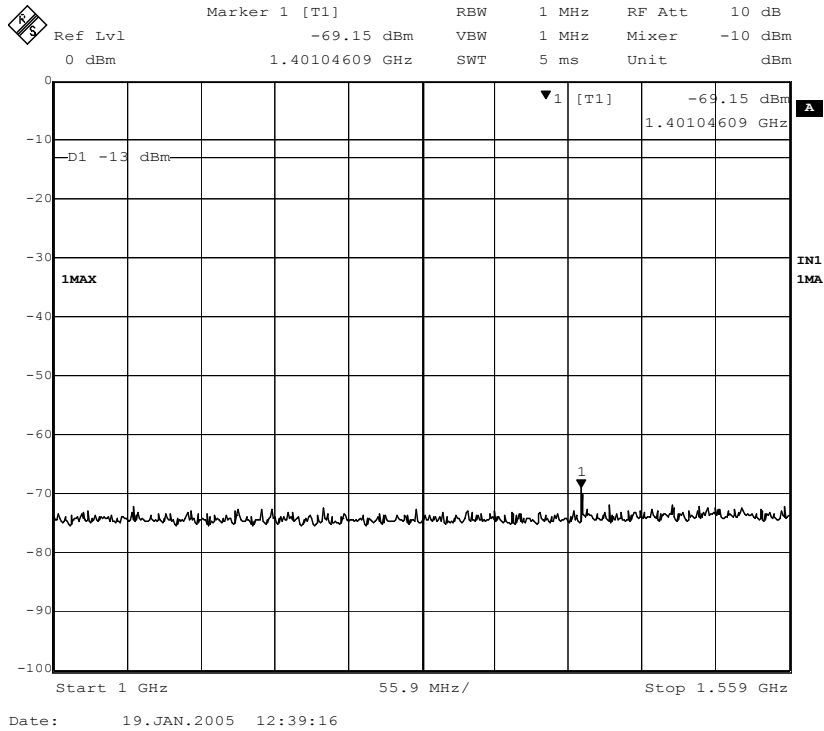

1000MHz – 1559MHz

RU1074/4830

TRANSMITTER SPURIOUS EMISSIONS – Radiated

Channel 1

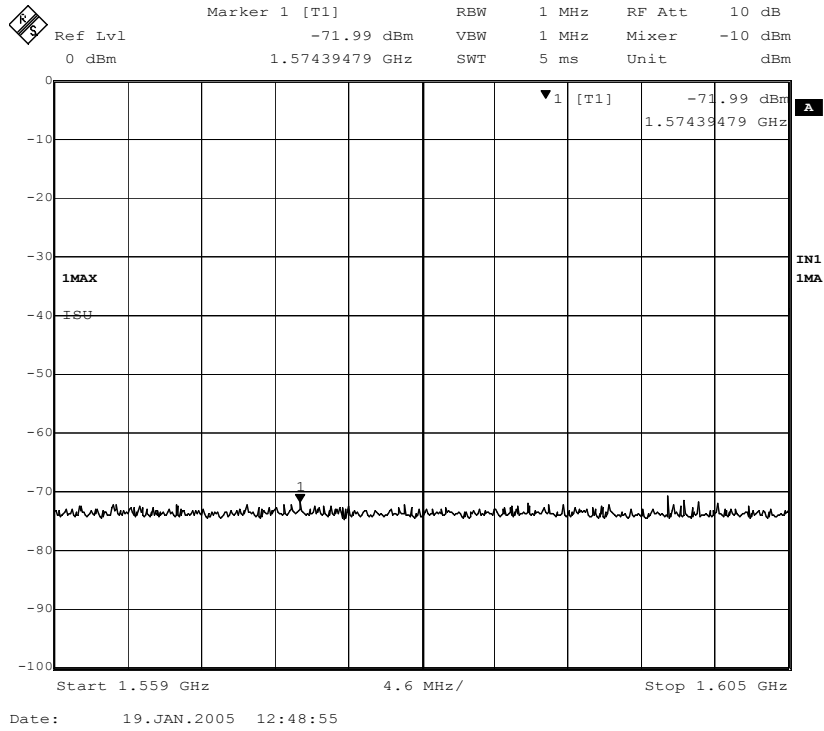

1559MHz – 1605MHz

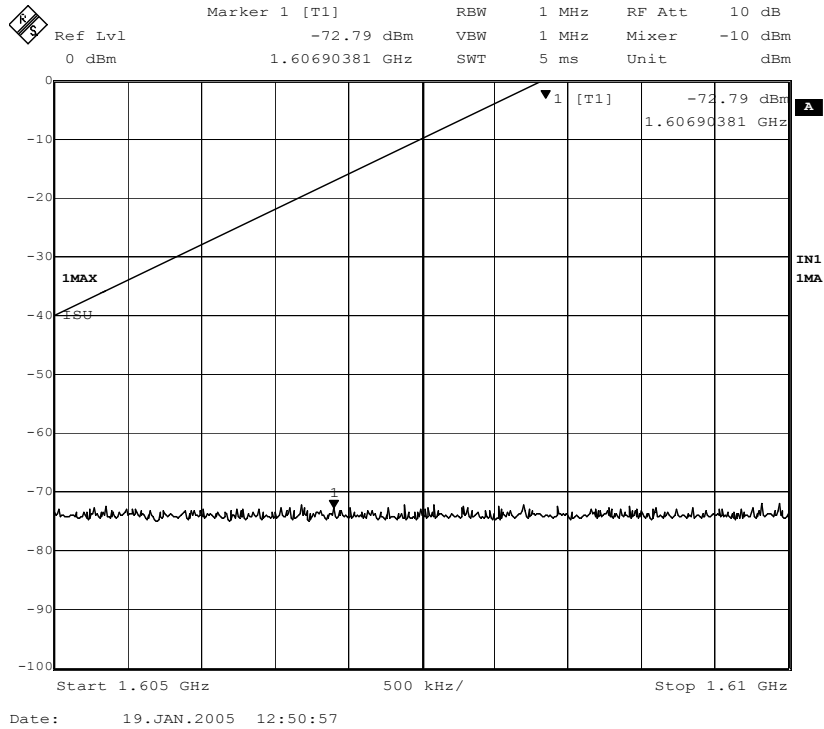

1605MHz – 1610MHz



TRANSMITTER SPURIOUS EMISSIONS – Radiated

Channel 1

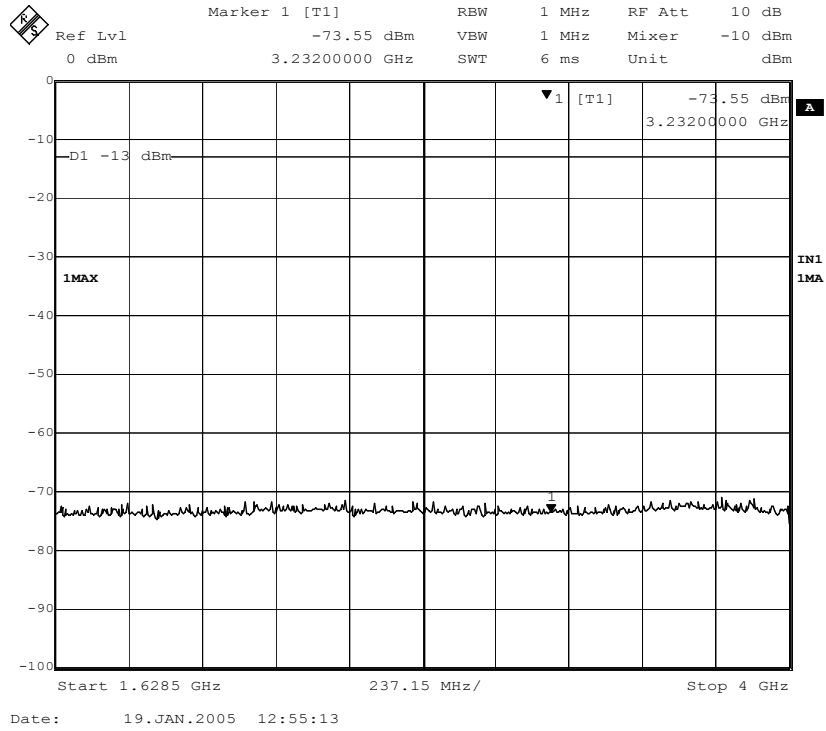

1628.5MHz – 4000MHz

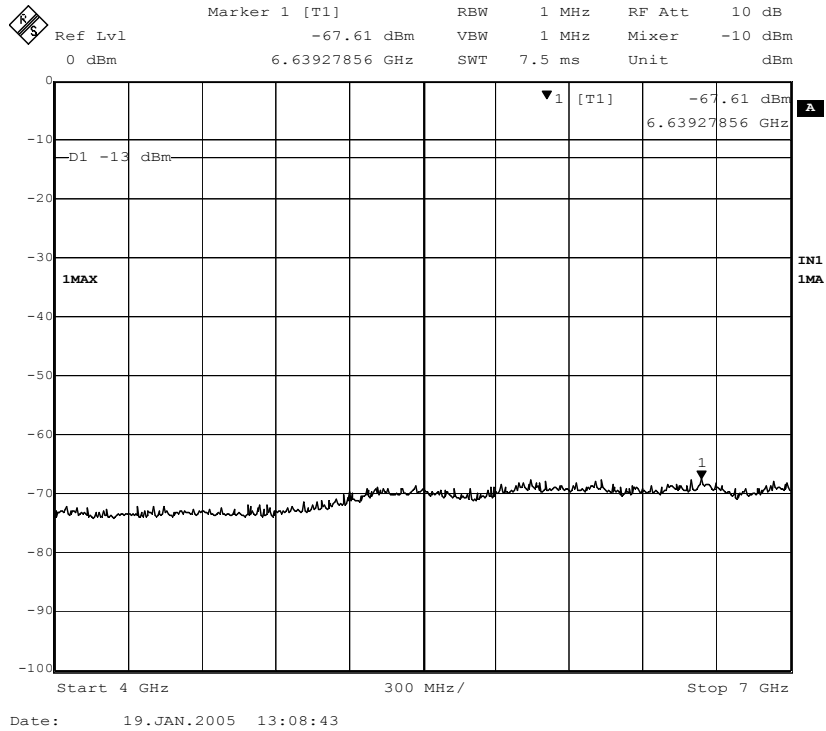

4GHz – 7GHz

RU1074/4830

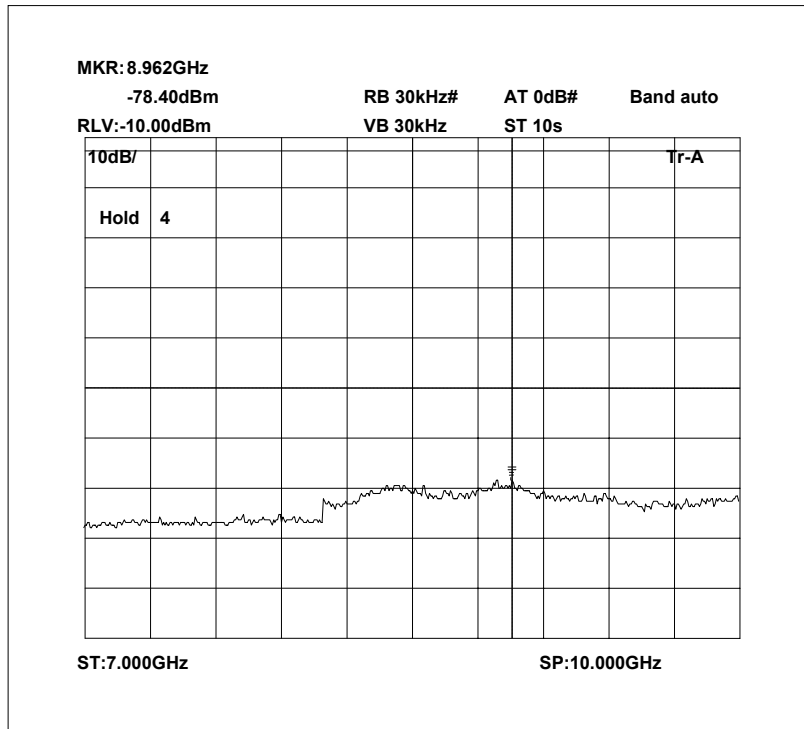

7GHz – 10GHz

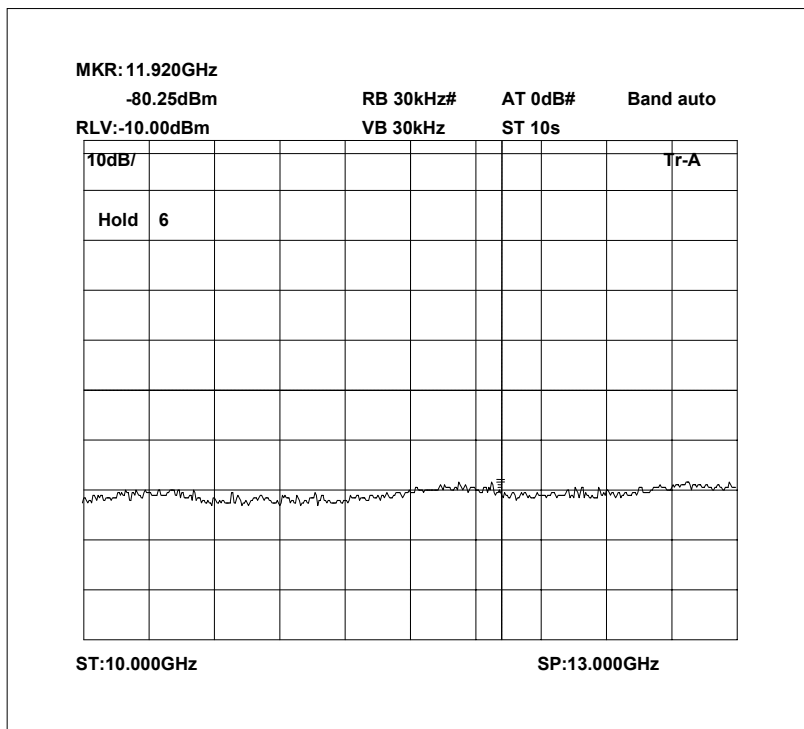

10GHz – 13GHz

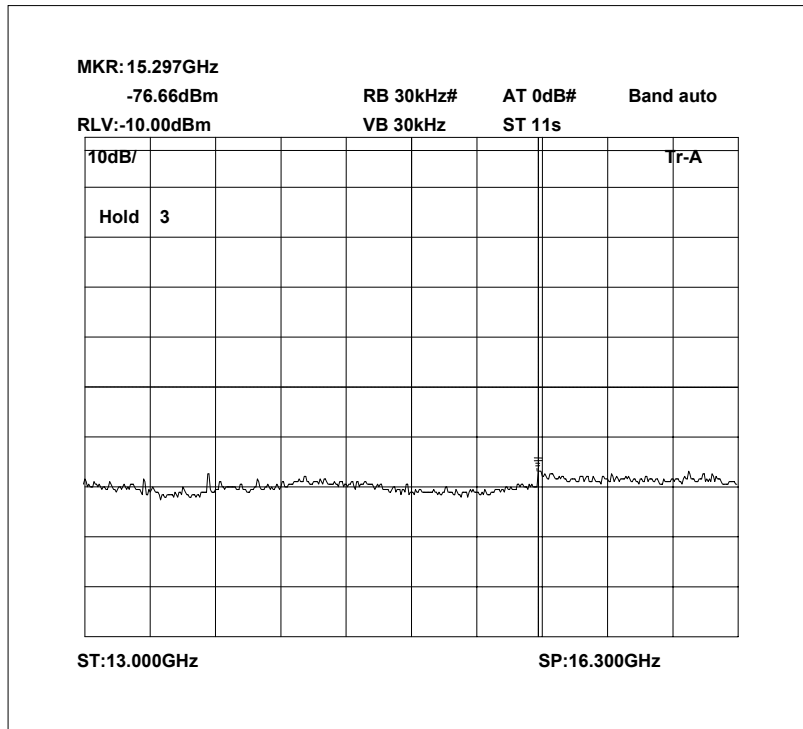

13GHz – 16.3GHz

TRANSMITTER SPURIOUS EMISSIONS – Radiated

Channel 240

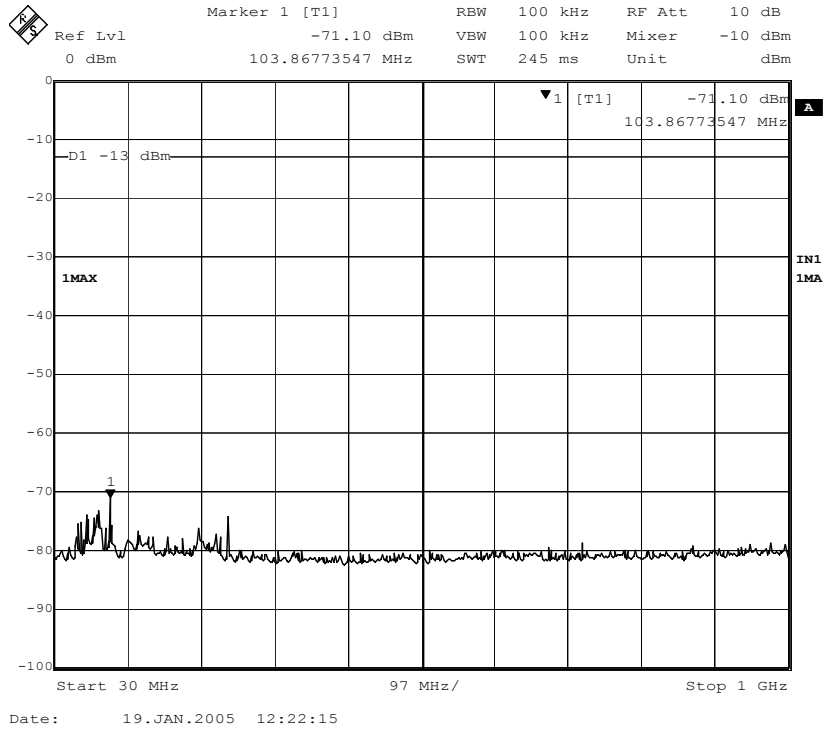

30MHz – 1000MHz

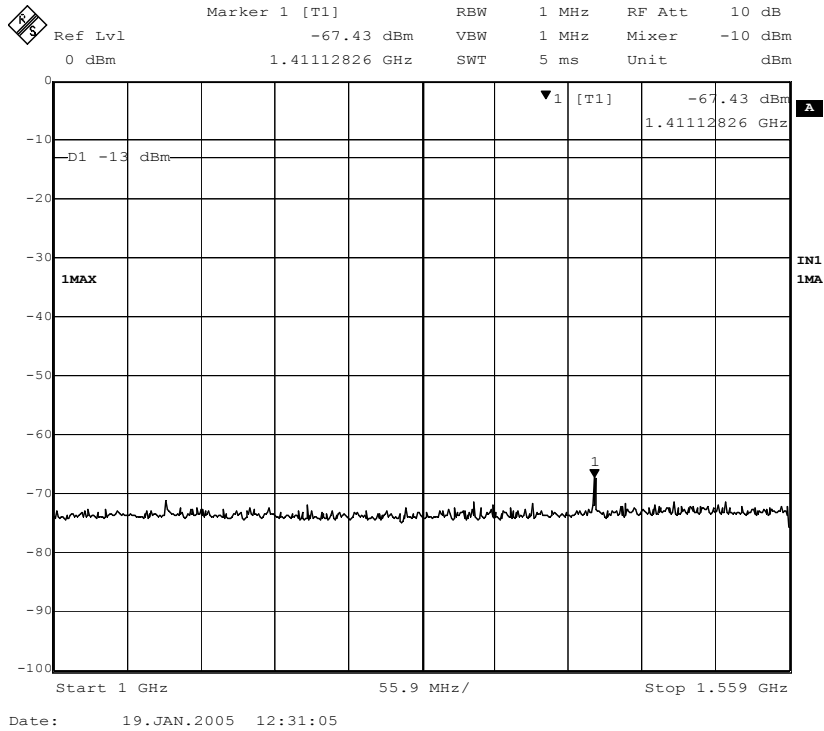

1000MHz – 1559MHz

RU1074/4830

TRANSMITTER SPURIOUS EMISSIONS – Radiated

Channel 240

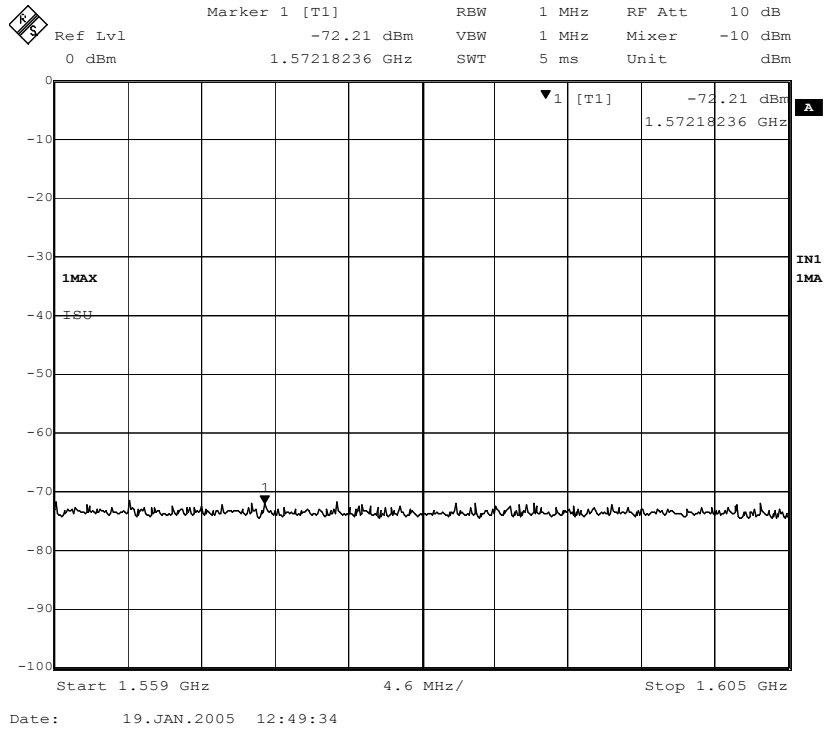

1559MHz – 1605MHz

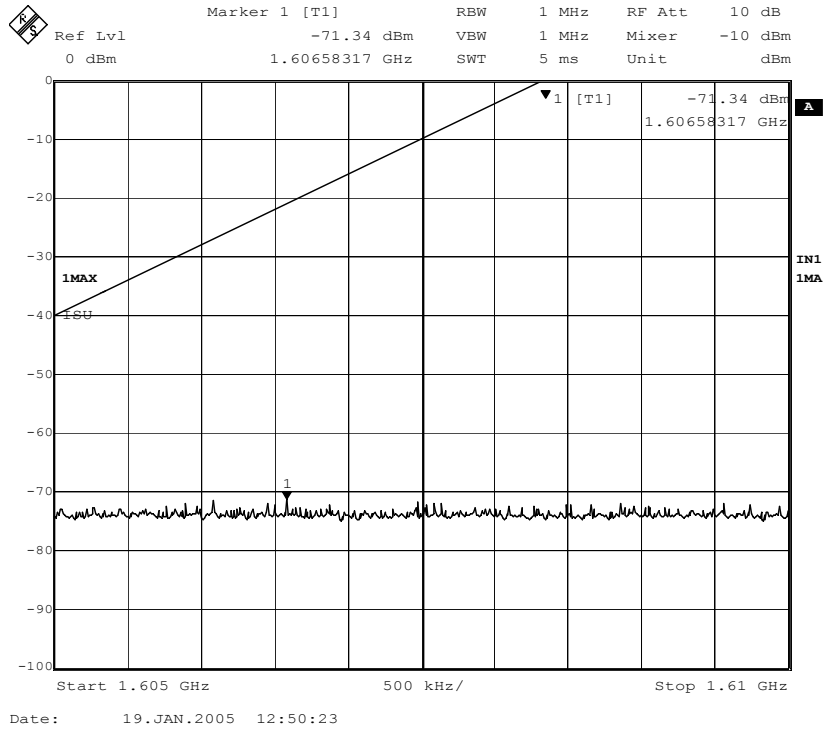

1605MHz – 1610MHz

RU1074/4830

TRANSMITTER SPURIOUS EMISSIONS – Radiated

Channel 240

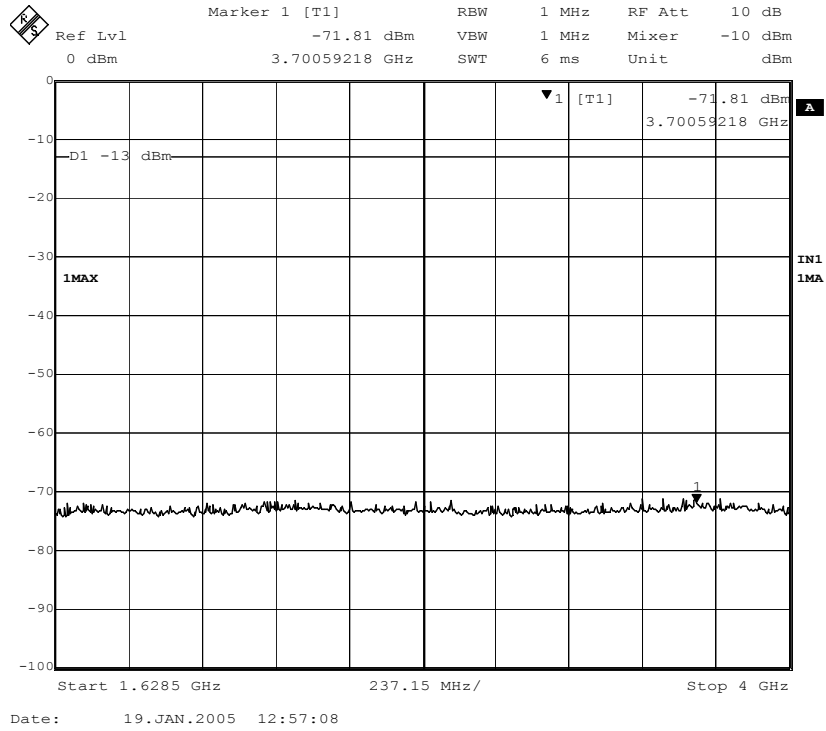

1628.5MHz – 4000MHz

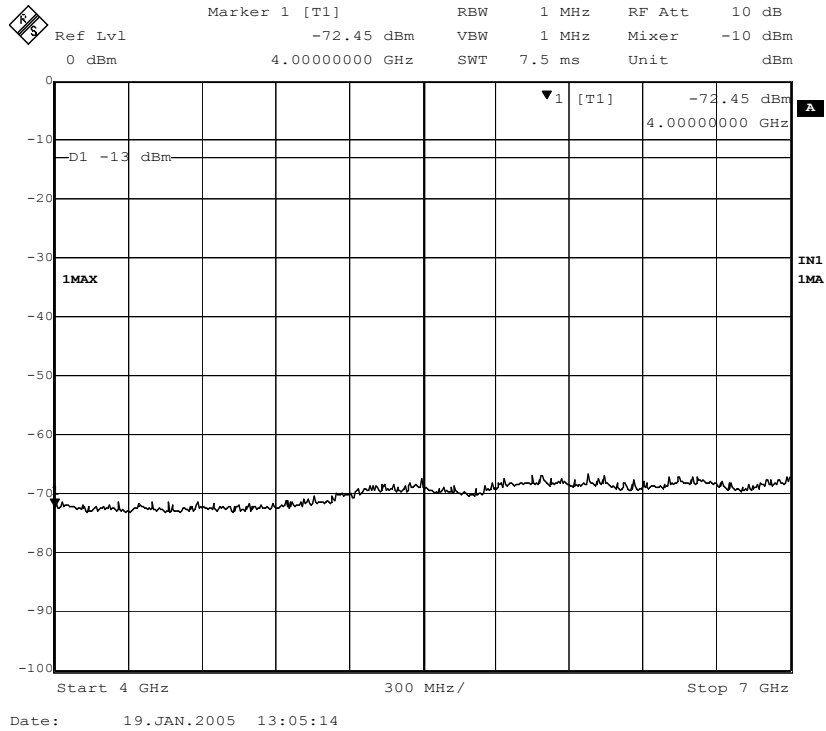

4GHz – 7GHz

RU1074/4830

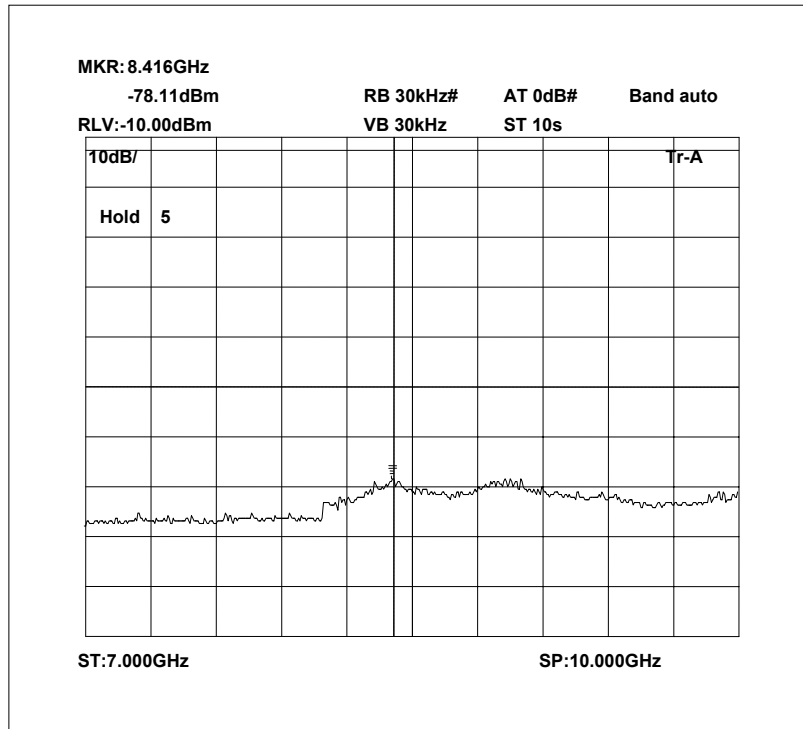

7GHz – 10GHz

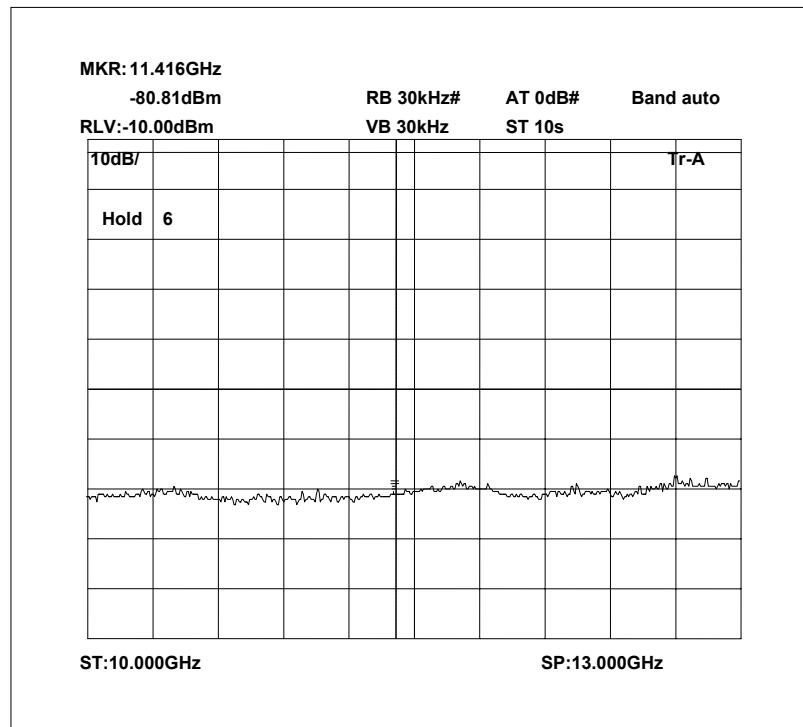

10GHz – 13GHz

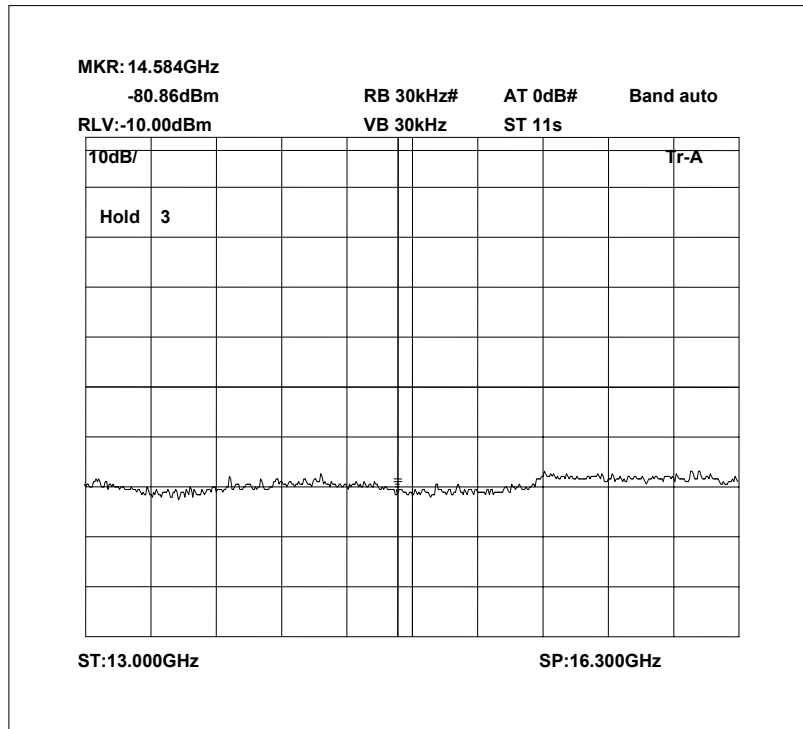

13GHz – 16.3GHz



**ANNEX I**  
**FREQUENCY STABILITY - Temperature**

Channel 1 Frequency Stability - Temperature

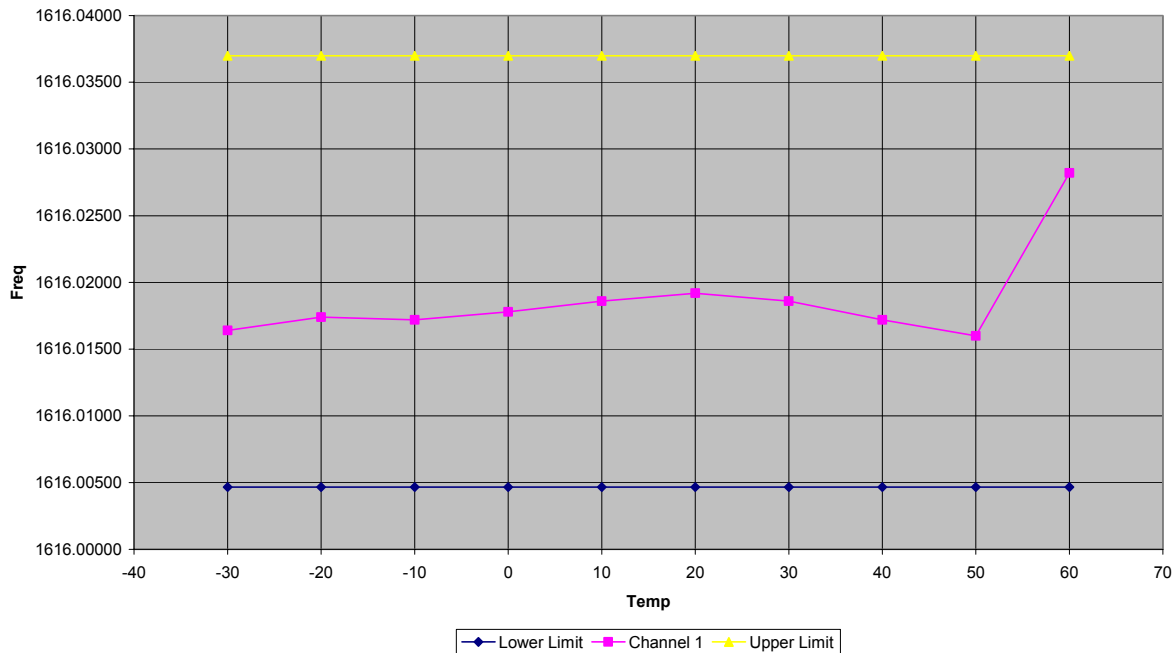

Channel 75 Frequency Stability - Temperature

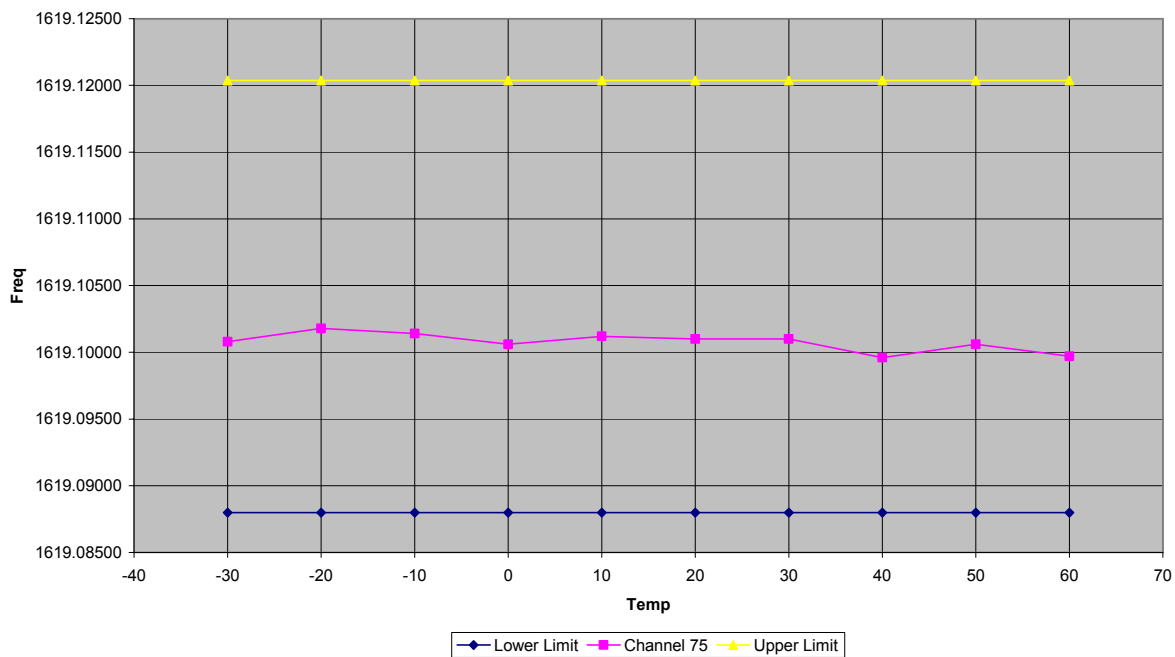

Channel 150 Frequency Stability - Temperature

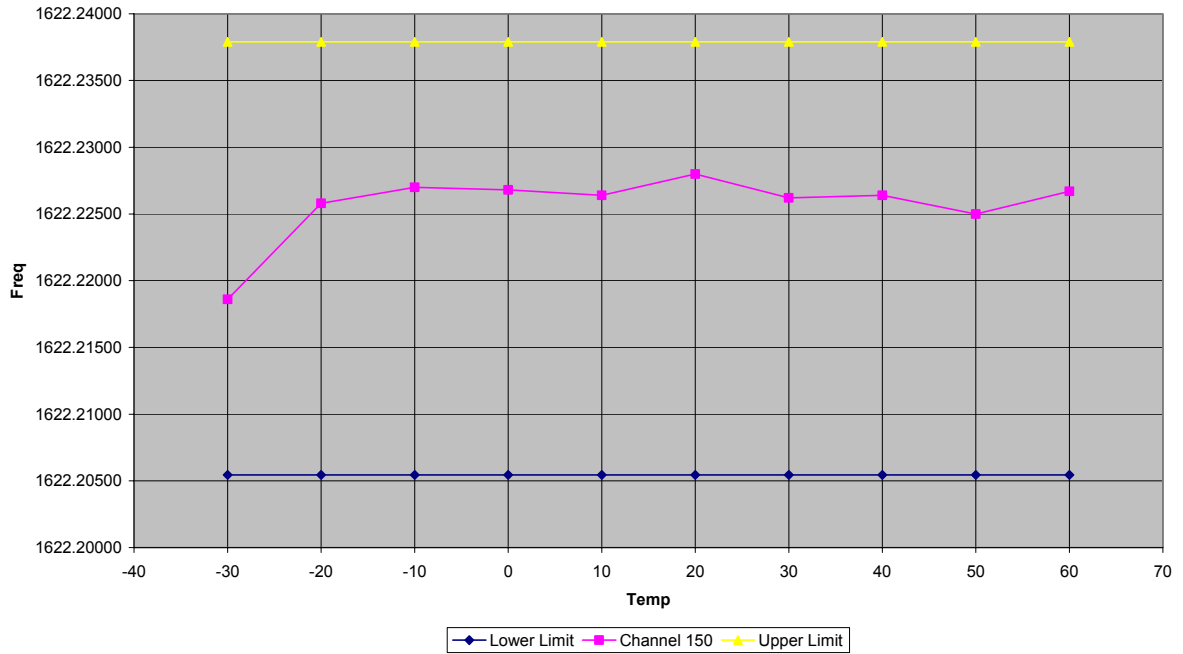

Channel 240 Frequency Stability - Temperature

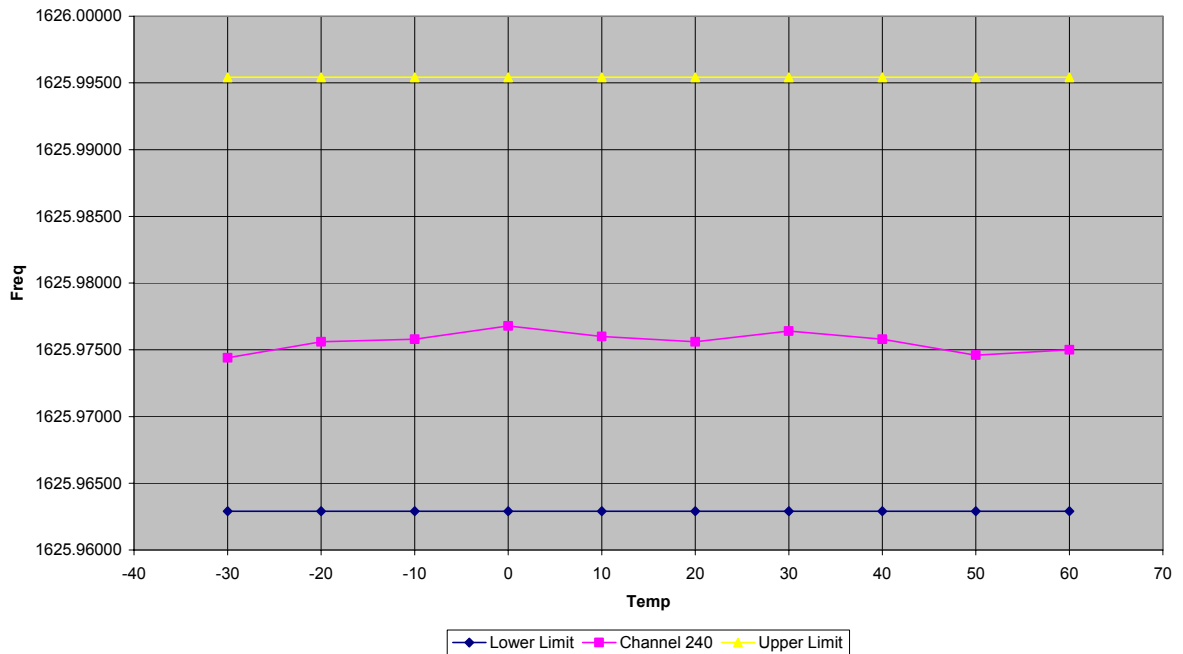

**ANNEX J**  
**FREQUENCY STABILITY – Voltage**

Channel 1 Frequency Stability - Voltage

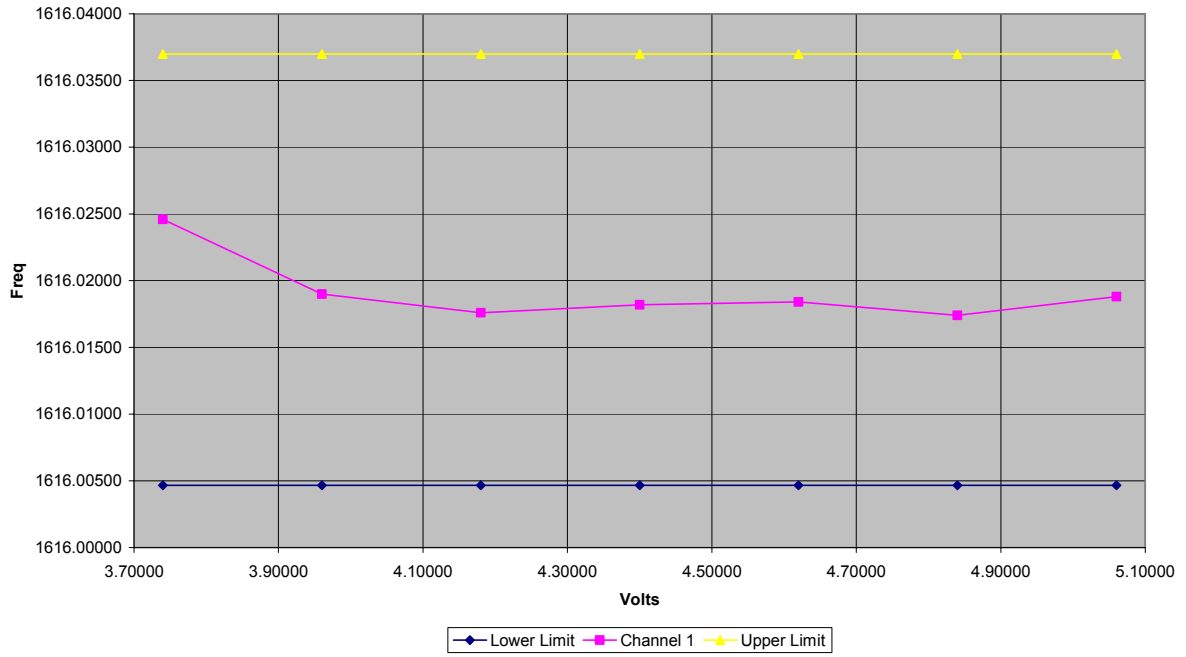

Channel 75 Frequency Stability - Voltage

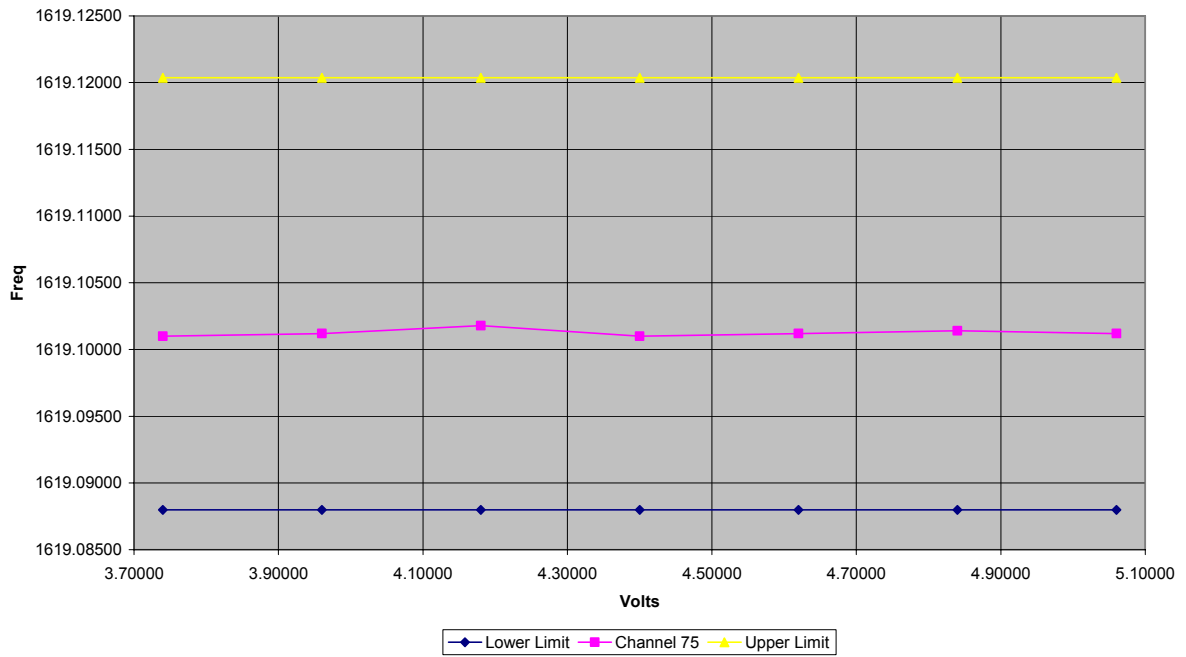

Channel 150 Frequency Stability - Voltage

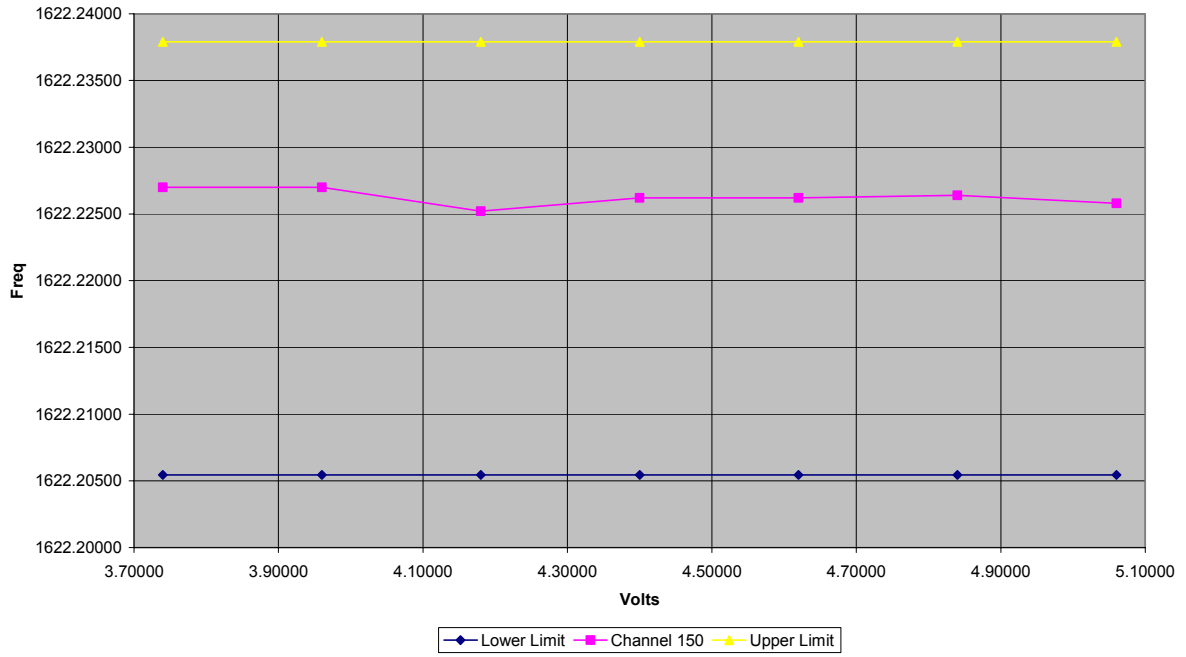

Channel 240 Frequency Stability - Voltage

