



Product Service

---

**Choose certainty.  
Add value.**

# Report On

Radio Testing of the  
Thrane & Thrane A/S SAILOR 6390 Navtex Receiver  
In accordance with IEC 61097-6

COMMERCIAL-IN-CONFIDENCE

Document 75923004 Report 04 Issue 2

November 2013



Product Service

TÜV SÜD Product Service, Octagon House, Concorde Way, Segensworth North,  
Fareham, Hampshire, United Kingdom, PO15 5RL  
Tel: +44 (0) 1489 558100. Website: [www.tuv-sud.co.uk](http://www.tuv-sud.co.uk)

COMMERCIAL-IN-CONFIDENCE

**REPORT ON**

Radio Testing of the  
Thrane & Thrane A/S SAILOR 6390 Navtex receiver  
In accordance with IEC 61097-6

Document 75923004 Report 04 Issue 2

November 2013

**PREPARED FOR**

Thrane & Thrane A/S  
Lundotoftegaardsvej 93D  
DK-2880 Kgs  
Lynby  
2800  
DENMARK

**PREPARED BY**

  
\_\_\_\_\_  
**Nic Forsyth**  
Senior Engineer

**APPROVED BY**

  
\_\_\_\_\_  
**Robert Hampton**  
Authorised Signatory

**DATED**

\_\_\_\_\_  
08 November 2013

**This report has been revised to issue 2 to include additional results.**





## CONTENTS

Section	Page No
<b>1</b>	<b>REPORT SUMMARY ..... 3</b>
1.1	Introduction ..... 4
1.2	Brief Summary of Results ..... 5
1.3	Declaration of Build Status ..... 7
1.4	Product Information ..... 8
1.5	Deviations from the Standard ..... 9
1.6	Modification Record ..... 9
1.7	Alternative Test Site ..... 9
1.8	NAVTEX Test system ..... 10
<b>2</b>	<b>TEST DETAILS ..... 13</b>
2.1	Performance Requirements ..... 14
2.2	INS Input Electrical ..... 16
2.3	INS Input Performance ..... 17
2.4	INS Output Electrical ..... 18
2.5	INS Output Performance ..... 19
2.6	Printer Output Performance ..... 20
2.7	Exclusion of Stations ..... 21
2.8	Exclusion of Message Categories ..... 23
2.9	Receiver Test Facility ..... 25
2.10	Search and Rescue Alarm Provision and Reset ..... 26
2.11	Additional Alarms ..... 27
2.12	Call Sensitivity ..... 30
2.13	Interface Rejection and Blocking Immunity ..... 32
2.14	Co-channel Rejection ..... 35
2.15	Intermodulation ..... 36
2.16	Off-Frequency Transmitter ..... 38
2.17	Simultaneous Operation on Several Receive Frequencies ..... 39
2.18	Protection of Input Circuits ..... 40
2.19	Tests of Technical Characteristics (ITU-Recommendation M.540) ..... 42
2.20	Internal Storage, Message Tagging and Erasure of Oldest Message Identification ..... 44
2.21	Erasure of Message Identifications / Storage Time ..... 46
2.22	Reception of Messages with Character Errors ..... 47
2.23	Unsatisfactory Reception ..... 49
2.24	Power-Off Check ..... 50
2.25	Brown-Out Test ..... 51
2.26	UTC Handling Check ..... 52
2.27	Spurious Emissions ..... 53
2.28	Equipment Manuals ..... 54
2.29	Marking and Identification ..... 56
<b>3</b>	<b>TEST EQUIPMENT USED ..... 58</b>
3.1	Test Equipment Used ..... 59
3.2	Measurement Uncertainty ..... 66
<b>4</b>	<b>PHOTOGRAPHS ..... 67</b>
4.1	Photographs of Equipment Under Test (EUT) ..... 68
<b>5</b>	<b>ACCREDITATION, DISCLAIMERS AND COPYRIGHT ..... 70</b>
5.1	Accreditation, Disclaimers and Copyright ..... 71



Product Service

## **SECTION 1**

### **REPORT SUMMARY**

Radio Testing of the  
Thrane & Thrane A/S SAILOR 6390 Navtex receiver  
In accordance with IEC 61097-6



Product Service

## 1.1 INTRODUCTION

The information contained in this report is intended to show verification of the Radio Testing of the Thrane & Thrane A/S SAILOR 6390 Navtex receiver to the requirements of IEC 61097-6.

Objective	To perform Radio Testing to determine the Equipment Under Test's (EUT's) compliance with the Test Specification, for the series of tests carried out.
Manufacturer	Thrane & Thrane A/S
Model Number(s)	SAILOR 6390 Navtex receiver
Serial Number(s)	65700635240027 65700635240029 65700635240030
Number of Samples Tested	3
Test Specification/Issue/Date	IEC 61097-6 (2005-12)
Order Number	P2620
Date	31 May 2013
Start of Test	27 August 2013
Finish of Test	21 October 2013
Name of Engineer(s)	N Forsyth M Russell
Reference Documents	IEC 61162-1: 2010 IEC 61162-2: 1998 IEC 60945: 2002



## 1.2 BRIEF SUMMARY OF RESULTS

A brief summary of the tests carried out in accordance with IEC 61097-6 is shown below.

Section	Spec Clause	Test Description	Result	Comments/Base Standard
2.1	4	Performance Requirements	Pass	
2.2	7.1	INS Input Electrical	Pass	
2.3	7.2	INS Input Performance	Pass	
2.4	7.3	INS Output Electrical	Pass	
2.5	7.4	INS Output Performance	Pass	
2.6	7.5	Printer Output Electrical	N/A	Printer connected via Ethernet and cannot be tested via serial interface. Therefore it is not possible or applicable to perform electrical testing.
2.7	7.6	Printer Output Performance	Pass	
2.8	8.1	Exclusion of Stations	Pass	
2.9	8.2	Exclusion of Message Categories	Pass	
2.10	8.3	Receiver Test Facility	Pass	
2.11	8.4	Search and Rescue Alarm Provision and Reset	Pass	
2.12	8.5	Additional Alarms	Pass	
2.13	9.1	Call Sensitivity	Pass	
2.14	9.2	Interference Rejection and Blocking Immunity	Pass	
2.15	9.3	Co-channel Rejection	Pass	
2.16	9.4	Intermodulation	Pass	
2.17	9.5	Off-Frequency Transmitter	Pass	
2.18	9.6	Simultaneous Operation on Several Receive Frequencies	Pass	



Product Service

Section	Spec Clause	Test Description	Result	Comments/Base Standard
2.19	9.7	Protection of Input Circuits	Pass	
2.20	10.5	Tests of Technical Characteristics (ITU-R Recommendation M.540)	Pass	
2.21	11.1	Internal Storage, Message Tagging and Erasure of Oldest Message Identification	Pass	
2.22	11.2	Erasure of Message Identifications / Storage Time	Pass	
2.23	11.4	Reception of Messages with Character Errors	Pass	
2.24	11.5	Unsatisfactory Reception	Pass	
2.25	11.6	Power-Off Check	Pass	
2.26	11.7	Brown-Out Test	Pass	
2.27	11.8	UTC Handling Check	Pass	
2.28	12.1	Spurious Emissions	Pass	
2.29	12.2	Equipment Manuals – checks of the manufacturer's documentation	Pass	
2.30	12.3	Marking and identification	Pass	



Product Service

### 1.3 DECLARATION OF BUILD STATUS

<b>Manufacturer</b>	Thrane & Thrane A/S
<b>Country of origin</b>	Denmark
<b>Technical Description</b>	Navtex Receiver
<b>Model No</b>	TT-6390A
<b>Part No</b>	406390A
<b>Serial No</b>	XXX
<b>Drawing Number</b>	97-137247-P01 (P: preliminary)
<b>Build Status</b>	Prototype build
<b>Software Issue</b>	1.00
<b>Hardware Issue</b>	Rev. B
<b>FCC ID</b>	ROJ6390
<b>IC ID</b>	
<b>Highest Operating Frequency</b>	300MHz (DSP clock)
<b>Signature</b>	Jesper Holst
<b>Date</b>	2013-06-06
<b>D of B S Serial No</b>	1

Note: This document has been prepared to enable manufacturers with no mechanism for producing their own Declaration of Build Status, to declare the build state of the equipment submitted for test.





## 1.4 PRODUCT INFORMATION

### 1.4.1 Technical Description

The Equipment Under Test (EUT) was a Thrane & Thrane A/S SAILOR 6390 Navtex receiver as shown below . A full technical description can be found in the manufacturer's documentation.



Equipment Under Test



## 1.5 DEVIATIONS FROM THE STANDARD

No deviations from the applicable test standard were made during testing.

## 1.6 MODIFICATION RECORD

The following modifications were made to the EUT during testing:

Modification State	Description of Modification	SW Version	Modification Fitted by	Date of Modification
0	As supplied by the customer	0.96	Not Applicable	Not Applicable
1	Three resistors removed at the output terminals of the NMEA transmitter. These resistors are noted as R832, R833 and R835 on schematic diagrams to be separately submitted with the technical construction file.	0.96	Erik Anderson of Thrane & Thrane A/S in the presence of M Russell.	28 August 2013
2	Software update to version 0.98 for modifications to algorithms used for filtering of b1 and b2 characters.	0.98	Jesper Holst of Thrane & Thrane A/S in the presence of M Russell.	30 August 2013
3	Software update to version 1.00	1.00	Jesper Holst of Thrane & Thrane A/S	14 October 2013

## 1.7 ALTERNATIVE TEST SITE

Testing of the following clauses was performed at Thrane & Thrane A/S in Aalborg, Denmark, in the presence of Mr Jesper Holst and Mr Eric Anderson of Thrane & Thrane A/S: 7.3, 7.4, 7.6, 8.1, 8.2, 9.1, 9.2, 9.3, 9.4, 9.5, 9.6, 9.7, 10.5, 11.1, 11.4, 11.5, 11.6, 11.7, 12.1 and 12.3.



1.8 NAVTEX TEST SYSTEM

The test equipment shown in the diagram below was used to generate the standard test signal (STS) in accordance with ITU-R Recommendation M.625, Annex I,4, collective B-mode and unwanted test signals (if applicable).

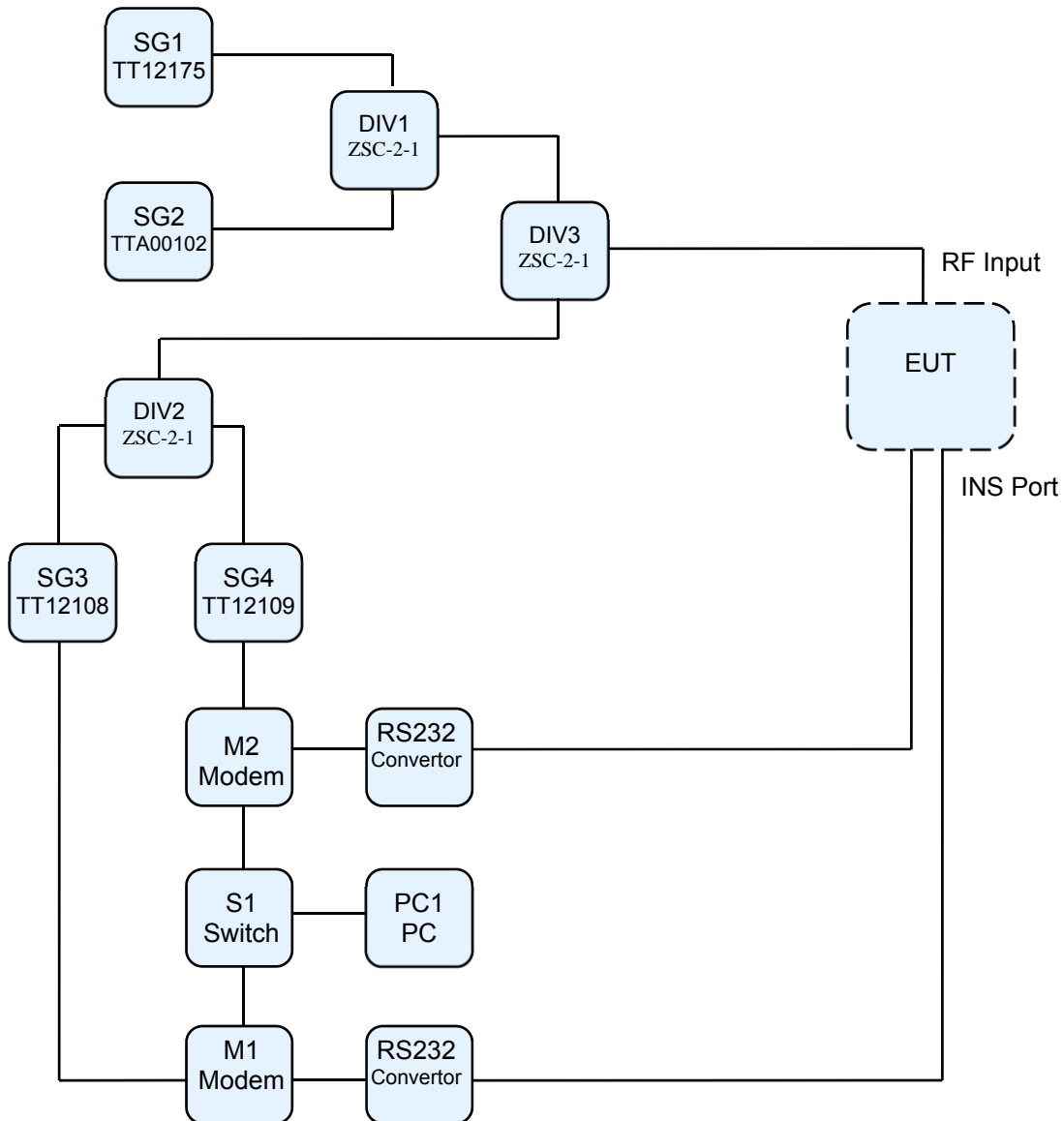

SG4/M2 was used for both 490.0 kHz and 4209.5 kHz whilst SG3/M1 was used for 518.0 kHz. 4209.5 kHz was set on SG4/M2 in the scenario where 490.0 kHz and 4209.5 kHz were applied simultaneously (Simultaneous reception on several receive frequencies – Clause 9.6).



Product Service

The mark and space transmitter frequency tolerance were measured using a frequency counter by fixing the 2FSK trigger input of the signal generator at + 5.0V and - 5.0V respectively.

	Measured Tolerance (Hz)	Tolerance Limit (Hz)
Mark	+0.720	±10
Space	-0.573	

The baud rate of the system was then verified by checking the frequency offset between the carrier frequency and the first upper sideband.



Baud Rate: 49.85 Hz

The outputs of the modems were connected to the 2FSK trigger inputs of the signal generators which were set to a level corresponding to -107 dBm at the EUT. An external 10 MHz reference was used to phase lock the all of the signal generators.

The loss through the test system was measured as:

Frequency (kHz)	Loss (dB) – 50Ω Artificial Antenna	Loss (dB) 10Ω High Impedance Artificial Antenna (Note 1)
490.0	6.9	29.1
518.0	7.0	30.5
4209.5	7.1	30.6



For ease of testing purposes only, it was assumed that the path loss of the system with the 50 Ω artificial antenna was 6.0 dB and 29.5 dB for the 10 Ω high impedance antenna. This was deemed a “worst case” scenario as the wanted signal level at the EUT would be lower than the relevant level required. In all cases, interfering signals were calibrated to the level required by the standard at the EUT receiver.

Note 1: Calculation of 10 Ω high impedance loss:

**50ohm to 10ohm / 150pF converter**

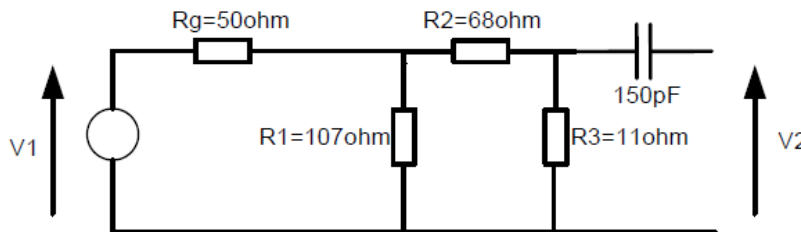

Calculated EMF attenuation:

$$V2/V1 = (R3 \cdot R1) / (R2 + R3) \cdot (Rg + R1) + (Rg \cdot R1)$$

Values of resistors and capacitor inserted result in  $20 \cdot \log(V2/V1) = 23.5 \text{ dB}$

To ensure the validity of the assumption above the power attenuation was measured by means of Spectrum Analyser and Tracking Generator.

Pin av = -20.0dBm ⇒ EMFin = 93.0dBuV  
 Pout = -70.0dBm =  $100.00 \cdot 10^{-12} \text{ W}$  (result from analyser).

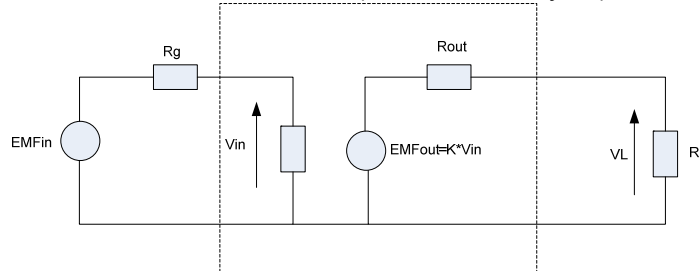

The output impedance Rout at 518.0 kHz is estimated to be equal to the capacitive part of the artificial antenna resulting in:

$$R_{out} = \frac{1}{2\pi f C} = \frac{1}{2\pi \cdot 518 \cdot 10^3 \cdot 150 \cdot 10^{-12}} = 2049.4 \Omega$$

$$EMF_{out} = V_L \cdot \frac{R_{out} + R_L}{R_L} \quad \wedge \quad P_{out} = \frac{V_L^2}{R_L} \Rightarrow V_L = \sqrt{P_{out} \cdot R_L}$$

Therefore:

$$EMF_{out} = \sqrt{P_{out} \cdot R_L} \cdot \frac{R_{out} + R_L}{R_L}$$

Following values inserted:

Pout = 100.00E-12 W    Rout = 2049.4 Ω    RL = 50 Ω

Results in:

EMFout = 2.969E-3 V = 69.45 dBμV

The loss in EMF is:

EMFout – EMFin = 69.45 – 93.0 = 23.55 dB

The difference between the calculated and measured values was 0.05 dB which can be considered negligible.



Product Service

## **SECTION 2**

### **TEST DETAILS**

Radio Testing of the  
Thrane & Thrane A/S SAILOR 6390 Navtex receiver  
In accordance with IEC 61097-6



## 2.1 PERFORMANCE REQUIREMENTS

### 2.1.1 Specification Reference

IEC 61097-6, Clause 4

### 2.1.2 Equipment Under Test and Modification State

SAILOR 6390 Navtex receiver S/N: 65700635240027 - Modification State 0

### 2.1.3 Date of Test

02 September & 14 October 2013

### 2.1.4 Test Equipment Used

The major items of test equipment used for the above tests are identified in Section 3.1.

### 2.1.5 Environmental Conditions

Ambient Temperature	21.9 to 24.4 °C
Relative Humidity	45.4 to 50.2 %

### 2.1.6 Test Results

The following test results show compliance with the performance requirements in section 4, where the requirements are not tested in the tests cases of sections 7, 8, 9, 10, 11 and 12.

#### Clause 4.3.7 – Controls and Indicators

It is not possible to exclude message types A, B D and L. In the “Filters” menu, available via the display, these message types are greyed out and cannot be modified. All other message types are readily available and can be included or excluded by checking or un-checking the message type.

#### Clause 4.3.8 - Programmable control memories

A factory reset was performed on the EUT and the location designators were set to all characters, A-Z. The message designators were set to ABCDEFHJKLVZ.

#### Clause 4.3.9 – Alarms

The search and rescue alarm has a different alarm sound than other alarms, is the only alarm that activates the alarm relay and is displayed differently on the user interface.

#### Clause 4.4 – Interfaces

The equipment has been tested to and complies with IEC 61162-1, see test report 75923004 Report 02.



Product Service

Clause 4.6.1.1 – User Interface

There is a control for adjusting the display illumination on the front of the display unit.

There are three indicator lights at the bottom of the display to indicate which receiver is currently receiving.

It is possible to select transmitter coverage area (B1) and message types (B2) independently for message storage, output to the INS port and output to printer port via the display. The setting for each output is performed via a different tab on the display unit to enable independent settings.

Clause 4.6.1.2 – Number of characters displayed per line

The display is capable of displaying more than 32 characters per line.

Clause 4.6.1.3 – Number of lines displayed

The display is capable of displaying more than 16 lines of text.

Clause 4.6.1.6 – Automatic Line feed

Automatic line feed of the display did not entail division of a word.

Clause 4.6.1.7 – End of message display

Individual messages can only be opened in turn using the touch screen. End of message is clearly indicated by the use of line feeds.

Clause 4.6.1.8 – Corrupt Characters

Corrupted characters were replaced by an asterix.

Clause 4.6.1.9 - Printer interface message selection requirements

It is possible to select the following data to be output to the printer.

Requirement	Result
All messages as they are received	Pass
All messages stored in the message memory	Pass
All messages received on specified frequencies, from specified locations or having specified message designators	Pass
All messages currently displayed	Pass
Individual messages selected from those appearing on the display	Pass

Clause 4.8.1.2 – Message Tagging

2000 messages were loaded from the standard test file onto the EUT. 495 messages were tagged automatically by communicating with the database directly, the ability to do this is not available to the user and only possible by the manufacturer. 5 messages were then tagged via the user interface. It was confirmed that it was not possible to tag any more messages, complying with the requirement that no more than 25% of the memory can be used for message retention.





Product Service

**2.2 INS INPUT ELECTRICAL**

**2.2.1 Specification Reference**

IEC 61097-6, Clause 7.1

**2.2.2 Equipment Under Test and Modification State**

SAILOR 6390 Navtex receiver S/N: 65700635240027 - Modification State 0

**2.2.3 Date of Test**

14 October 2013

**2.2.4 Test Equipment Used**

The major items of test equipment used for the above tests are identified in Section 3.1.

**2.2.5 Environmental Conditions**

Ambient Temperature 21.9 °C  
 Relative Humidity 45.4 %

**2.2.6 Test Results**

Navtex - Receiver

24 V DC Supply

Conditions	Result
The INS input port configured in accordance with IEC 61162-1 and IEC 61162-2, shall be tested according to the relevant standard with regard to minimum and maximum voltage and current at the input terminals.	Pass

Limit Clause 7.1

The interfaces shall fulfil the applicable requirements of IEC 61162-1 and IEC 61162-2.



Product Service

**2.3 INS INPUT PERFORMANCE**

**2.3.1 Specification Reference**

IEC 61097-6, Clause 7.2

**2.3.2 Equipment Under Test and Modification State**

SAILOR 6390 Navtex receiver S/N: 65700635240027 - Modification State 0

**2.3.3 Date of Test**

14 October 2013

**2.3.4 Test Equipment Used**

The major items of test equipment used for the above tests are identified in Section 3.1.

**2.3.5 Environmental Conditions**

Ambient Temperature      22.4 °C  
 Relative Humidity          46.7 %

**2.3.6 Test Results**

Navtex - Receiver

24.0 V DC Supply

Conditions	Result
Operate the input with simulated data that represent the receiver control functions defined in IEC 61097-6 Annex C, including messages with invalid and unavailable data formatters. This test shall include loading the EUT input with 100 % of the interface's capacity for a period of not less than 5 min. Check for correct operation of the EUT.	Pass

Limit Clause 7.2

Verify that the displayed data/EUT operation agrees with the simulated input data and that invalid and unavailable data formats do not stop/inhibit the correct operation of the EUT.



Product Service

**2.4 INS OUTPUT ELECTRICAL**

**2.4.1 Specification Reference**

IEC 61097-6, Clause 7.3

**2.4.2 Equipment Under Test and Modification State**

SAILOR 6390 Navtex receiver S/N: 65700635240030 - Modification State 1

**2.4.3 Date of Test**

28 August 2013 – 29 August 2013

**2.4.4 Test Equipment Used**

The major items of test equipment used for the above tests are identified in Section 3.1.

**2.4.5 Environmental Conditions**

Ambient Temperature 25.1°C  
 Relative Humidity 46.2%

**2.4.6 Test Results**

Navtex - Receiver

24.0 V DC Supply

Conditions	Result
The INS output port configured in accordance with IEC 61162-1 and IEC 61162-2, shall be tested according to the relevant standard with regard to minimum and maximum voltage and current driving capability at the output terminals.	Pass

Limit Clause 7.3

The interfaces shall fulfil the applicable requirements of IEC 61162-1 and IEC 61162-2.



Product Service

**2.5 INS OUTPUT PERFORMANCE**

**2.5.1 Specification Reference**

IEC 61097-6, Clause 7.4

**2.5.2 Equipment Under Test and Modification State**

SAILOR 6390 Navtex receiver S/N: 65700635240029 - Modification State 2

**2.5.3 Date of Test**

03 September 2013

**2.5.4 Test Equipment Used**

The major items of test equipment used for the above tests are identified in Section 3.1.

**2.5.5 Environmental Conditions**

Ambient Temperature 23.9°C  
 Relative Humidity 57.8%

**2.5.6 Test Results**

Navtex - Receiver

24.0 V DC Supply

Conditions	Result		
	490.0 kHz	518.0 kHz	4209.5 kHz
Set the EUT to output to the INS port so that it is loaded with 100 % of the interface's capacity. Check for correct operation of the EUT by checking for conformance with the performance check as detailed in IEC 61097-6 Clause 5.3.	Pass	Pass	Pass

Limit Clause 7.4

Verify that the output data/EUT operation agrees with the requested output data.



Product Service

**2.6 PRINTER OUTPUT PERFORMANCE**

**2.6.1 Specification Reference**

IEC 61097-6, Clause 7.6

**2.6.2 Equipment Under Test and Modification State**

SAILOR 6390 Navtex receiver S/N: 65700635240029 - Modification State 2

**2.6.3 Date of Test**

03 September 2013

**2.6.4 Test Equipment Used**

The major items of test equipment used for the above tests are identified in Section 3.1.

**2.6.5 Environmental Conditions**

Ambient Temperature 23.9°C  
 Relative Humidity 57.8%

**2.6.6 Test Results**

Navtex - Receiver

24.0 V DC Supply

Conditions	Result		
	490.0 kHz	518.0 kHz	4209.5 kHz
Set the EUT to output to the printer port so that it is loaded with 100 % of the interface's capacity. Check for correct operation of the EUT by checking for conformance with the performance check as detailed in IEC 61097-6 Clause 5.3.	Pass	Pass	Pass

Limit Clause 7.6

Verify that the output data/EUT operation agrees with the requested output data.



Product Service

**2.7 EXCLUSION OF STATIONS**

**2.7.1 Specification Reference**

IEC 61097-6, Clause 8.1

**2.7.2 Equipment Under Test and Modification State**

SAILOR 6390 Navtex receiver S/N: 65700635240029 - Modification State 2

**2.7.3 Date of Test**

30 August 2013

**2.7.4 Test Equipment Used**

The major items of test equipment used for the above tests are identified in Section 3.1.

**2.7.5 Environmental Conditions**

Ambient Temperature	24.7°C
Relative Humidity	53.3%



Product Service

**2.7.6 Test Results**

Navtex - Receiver

24.0 V DC Supply

Conditions	Result
490.0 kHz: Disable D Q T stations to the Display only. Enable N O P Q R S T U V W X Y Z stations to the INS Port only. Enable A C E G I K M O Q S U W Y stations to the printer. 490.0 kHz: D Q T station message not displayed. N O P Q R S T U V W X Y Z station message sent to INS port. A C E G I K M O Q S U W Y station message sent to printer.	All except D Q T station messages displayed. Only N O P Q R S T U V W X Y Z station messages sent to INS port. Only A C E G I K M O Q S U W Y station messages sent to printer.
518.0 kHz: Enable A B C D E F G H I J K L M N O P Q R S stations to the Display only. Enable B D F H J L N P R T V X Z stations to the INS Port only. Enable A E I M Q U Y stations to the printer only. 518.0 kHz: A B C D E F G H I J K L M N O P Q R S station message displayed. B D F H J L N P R T V X Z station message sent to INS port. A E I M Q U Y station message sent to printer.	Only A B C D E F G H I J K L M N O P Q R S station messages displayed. Only B D F H J L N P R T V X Z station messages sent to INS port. Only A E I M Q U Y station messages sent to printer.
4209.5 kHz: Enable B D F H J L N P R T V X Z stations to the Display Only. Enable B C D J N R X stations to the INS Port Only. Enable A B G H I J O P Q R W X Y Z stations to the printer. 4209.5 kHz: B D F F H J L N P R T V X W station message displayed. B C D J N R X station message sent to INS port. A B G H I J O P Q R W X Y station message sent to printer.	Only B D F F H J L N P R T V X W station messages displayed. Only B C D J N R X station messages sent to INS port. Only A B G H I J O P Q R W X Y station messages sent to printer.

Limit Clause 8.1.2

For each value of B<sub>1</sub> not selected, the EUT shall neither display nor print the test message.



Product Service

**2.8 EXCLUSION OF MESSAGE CATEGORIES**

**2.8.1 Specification Reference**

IEC 61097-6, Clause 8.2

**2.8.2 Equipment Under Test and Modification State**

SAILOR 6390 Navtex receiver S/N: 65700635240029 - Modification State 2

**2.8.3 Date of Test**

30 August 2013

**2.8.4 Test Equipment Used**

The major items of test equipment used for the above tests are identified in Section 3.1.

**2.8.5 Environmental Conditions**

Ambient Temperature	24.7°C
Relative Humidity	53.3%





Product Service

**2.8.6 Test Results**

Navtex - Receiver

24 V DC Supply

Conditions	Result
490.0 kHz: Disable D Q T category messages to the Display only. Enable N O P Q R S T U V W X Y Z category messages to the INS Port only. Enable A C E G I K M O Q S U W Y category messages to the printer. 490.0 kHz: D Q T category messages not displayed. N O P Q R S T U V W X Y Z category messages sent to INS port. A C E G I K M O Q S U W Y category message sent to printer.	All except D Q T category messages displayed. Only N O P Q R S T U V W X Y Z category messages sent to INS port. Only A C E G I K M O Q S U W Y category messages sent to printer.
518.0 kHz: Enable A B C D E F G H I J K L M N O P Q R S category messages to the Display only. Enable B D F H J L N P R T V X Z category messages to the INS Port only. Enable A E I M Q U Y category messages to the printer only. 518.0 kHz: A B C D E F G H I J K L M N O P Q category messages displayed. B D F H J L N P R T V X Z category messages sent to INS port. A E I M Q U Y category messages sent to printer.	Only A B C D E F G H I J K L M N O P Q R S category messages displayed. Only B D F H J L N P R T V X Z station messages sent to INS port. Only A E I M Q U Y station messages sent to printer.
4209.5 kHz: Enable B D F H J L N P R T V X Z category messages to the Display Only. Enable B C D J N R X category messages to the INS Port Only. Enable A B G H I J O P Q R W X Y Z category messages to the printer. 4209.5 kHz: B D F H J L N P R T V X Z category messages displayed. B C D J N R X station message sent to INS port. A B G H I J O P Q R W X Y category messages sent to printer.	Only B D F H J L N P R T V X Z category messages displayed. Only B C D J N R X category messages sent to INS port. Only A B G H I J O P Q R W X Y category messages sent to printer.

Limit Clause 8.2.2

The EUT shall display *or print* the messages with the currently programmed B<sub>2</sub> characters, and also the messages with the B<sub>2</sub> characters A, B, D and L.



Product Service

**2.9 RECEIVER TEST FACILITY**

**2.9.1 Specification Reference**

IEC 61097-6, Clause 8.3

**2.9.2 Equipment Under Test and Modification State**

SAILOR 6390 Navtex receiver S/N: 65700635240027 - Modification State 0

**2.9.3 Date of Test**

14 October 2013

**2.9.4 Test Equipment Used**

The major items of test equipment used for the above tests are identified in Section 3.1.

**2.9.5 Environmental Conditions**

Ambient Temperature      22.1 °C  
 Relative Humidity          46.2 %

**2.9.6 Test Results**

Navtex - Receiver

24.0 V DC Supply

Conditions	Result
Self test check	Pass

Limit Clause 8.3.2

The test display/printout shall contain at least 36 valid characters and an indication of whether the test Passed or failed.

The test data shall be displayed but not stored in memory.



Product Service

**2.10 SEARCH AND RESCUE ALARM PROVISION AND RESET**

**2.10.1 Specification Reference**

IEC 61097-6, Clause 8.4

**2.10.2 Equipment Under Test and Modification State**

SAILOR 6390 Navtex receiver S/N: 65700635240027 - Modification State 0

**2.10.3 Date of Test**

14 October 2013

**2.10.4 Test Equipment Used**

The major items of test equipment used for the above tests are identified in Section 3.1.

**2.10.5 Environmental Conditions**

Ambient Temperature °C  
 Relative Humidity %

**2.10.6 Test Results**

Navtex - Receiver

24.0 V DC Supply

Conditions	Result
An alarm shall be activated.	Pass
An alarm can be reset manually via the user interface.	Pass
An alarm can be reset via the INS port and the use of the IEC 61162 'ACK' sentence.	Pass
The audible level of the alarm signal shall be measured to be between 75 dBA and 85 dBA.	Not applicable, EUT only has an alarm relay.

Limit Clause 8.4.2

An alarm shall be activated. The EUT shall be examined for the means whereby an alarm is generated.

It shall be demonstrated that that this alarm can be reset manually via the user interface in the case of an EUT with integral display.

It shall be demonstrated that this alarm can be reset via the INS port and the use of the IEC 61162 'ACK' sentence.

The audible level of the alarm signal shall be measured to be between 75 dBA and 85 dBA.



Product Service

**2.11 ADDITIONAL ALARMS**

**2.11.1 Specification Reference**

IEC 61097-6, Clause 8.5

**2.11.2 Equipment Under Test and Modification State**

SAILOR 6390 Navtex receiver S/N: 65700635240027 - Modification State 0

**2.11.3 Date of Test**

14 October 2013

**2.11.4 Test Equipment Used**

The major items of test equipment used for the above tests are identified in Section 3.1.

**2.11.5 Environmental Conditions**

Ambient Temperature 22.8 °C  
 Relative Humidity 45.9 %

**2.11.6 Test Results**

Navtex - Receiver

24.0 V DC Supply

Alarm 001: Navigational Warning		
Action	Sentence output from Navtex Receiver	Result
Message received with type A	\$CRALR,246060,001,A,V,NAVTEX: Navigational Warning	Pass
Alarm is acknowledged on display.	\$CRALR,246060,001,A,A,NAVTEX: Navigational Warning	Pass
Alarm is reset by reading the message on the display.	\$CRALR,246060,001,V,A,NAVTEX: Navigational Warning	Pass
Comments		
When this alarm is acknowledged with the ACK sentence, the alarm state is also reset as there is no way to confirm that the message has been read via the serial interface. There is no NMEA or proprietary sentence available for this function.		



Alarm 002: Meteorological Warning		
Action	Sentence output from Navtex Receiver	Result
Message received with type B	\$CRALR,246060,002,A,V,NAVTEX: Meteorological Warning	Pass
Alarm is acknowledged on display.	\$CRALR,246060,002,A,A,NAVTEX: Meteorological Warning	Pass
Alarm is reset by reading the message on the display.	\$CRALR,246060,002,V,A,NAVTEX: Meteorological Warning	Pass
Comments		
When this alarm is acknowledged with the ACK sentence, the alarm state is also reset as there is no way to confirm that the message has been read via the serial interface. There is no NMEA or proprietary sentence available for this function.		

Alarm 003: Search and Rescue Information		
Testing in clause 8.4.		

Alarm 004: Receiver Malfunction		
It is not possible to generate this alarm.		

Alarm 005: Built-in Self Test Failure		
Testing in clause 8.3.		

Alarm 006: General Failure		
It is not possible to generate this alarm.		

Alarm 060: Printer is offline		
Action	Sentence output from Navtex Receiver	Result
Printer is set offline	\$CRALR,246060,060,A,V,NAVTEX: Printer is offline	Pass
Alarm is acknowledged: \$CRACK,060	\$CRALR,246060,060,A,A,NAVTEX: Printer is offline	Pass
Printer is set online	\$CRALR,246060,060,V,A,NAVTEX: Printer is offline	Pass

Alarm 061: Printer is busy		
It is not possible to generate this alarm.		

Alarm 062: Printer is low on paper		
Action	Sentence output from Navtex Receiver	Result
Paper low sensor triggered	\$CRALR,246060,062,A,V,NAVTEX: Printer is low on paper	Pass
Alarm is acknowledged: \$CRACK,062	\$CRALR,246060,062,A,A,NAVTEX: Printer is low on paper	Pass
Paper low sensor reset	\$CRALR,246060,062,V,A,NAVTEX: Printer is low on paper	Pass



Alarm 063: Printer is out of paper		
Action	Sentence output from Navtex Receiver	Result
Paper is removed	\$CRALR,246060,063,A,V,NAVTEX: Printer is out of paper	Pass
Alarm is acknowledged: \$CRACK,063	\$CRALR,246060,063,A,A,NAVTEX: Printer is out of paper	Pass
Paper is installed	\$CRALR,246060,063,V,A,NAVTEX: Printer is out of paper	Pass

Alarm 064: Printer not connected		
Action	Sentence output from Navtex Receiver	Result
Power removed from printer	\$CRALR,246060,064,A,V,NAVTEX: Printer not connected	Pass
Alarm is acknowledged: \$CRACK,064	\$CRALR,246060,064,A,A,NAVTEX: Printer not connected	Pass
Printer powered on	\$CRALR,246060,064,V,A,NAVTEX: Printer not connected	Pass

Alarm 065: Printer error		
It is not possible to generate this alarm.		

Alarm 066: No default printer configured		
It is not possible to generate this alarm.		

Alarm 067: GPS alarm		
Action	Sentence output from Navtex Receiver	Result
GPRMC message removed for 10 mins	\$CRALR,151351.27,067,A,V,NAVTEX: GPS position lost	Pass
Alarm is acknowledged: \$CRACK,067	\$CRALR,151351.27,067,A,A,NAVTEX: GPS position lost	Pass
GPRMC message re-applied	\$CRALR,151351.27,067,V,A,NAVTEX: GPS position lost	Pass

Alarm 068: Automatic mode invalid		
Action	Sentence output from Navtex Receiver	Result
Automatic mode enabled and GPRMC message removed for 10 mins	\$CRALR,153920.67,068,A,V,NAVTEX: Automode invalid	Pass
Alarm is acknowledged: \$CRACK,068	\$CRALR,153920.67,068,A,A,NAVTEX: Automode invalid	Pass
Auto mode is then disabled and the alarm is reset after acknowledgement.	\$CRALR,153920.67,068,V,A,NAVTEX: Automode invalid	Pass

Limit Clause 8.5.2

It shall be demonstrated that such additional alarms can be suppressed.

It shall be demonstrated that such additional alarms can be reset.



Product Service

## 2.12 CALL SENSITIVITY

### 2.12.1 Specification Reference

IEC 61097-6, Clause 9.1

### 2.12.2 Equipment Under Test and Modification State

SAILOR 6390 Navtex receiver S/N: 65700635240029 - Modification State 0

### 2.12.3 Date of Test

26 August 2013

### 2.12.4 Test Equipment Used

The major items of test equipment used for the above tests are identified in Section 3.1.

### 2.12.5 Environmental Conditions

Ambient Temperature 24.9°C  
Relative Humidity 45.2%

### 2.12.6 Test Results

The test system was set up as described in section 1.8 and the level of the wanted signal was adjusted to a value corresponding to -107 dBm at the receiver input of the EUT for a type A artificial antenna and -99 dBm for a type B artificial antenna. The STS was repeated 25 times and the character error rate was calculated by analysing the messages received by the EUT.

#### Navtex - Receiver Antenna Type A

24.0 V DC Supply

Test Voltage (V DC)	RF Signal Level (dBm)	Test Frequency (kHz)	Error Rate (%)
24.0	-107.0	490.0	0 (No Errors)
		518.0	0 (No Errors)
		4209.5	0 (No Errors)



Product Service

Navtex - Receiver Antenna Type B

24.0 V DC Supply

Test Voltage (V DC)	RF Signal Level (dBm)	Test Frequency (kHz)	Error Rate (%)
24.0	-92.0	490.0	0 (No Errors)
		518.0	0 (No Errors)
		4209.6	0 (No Errors)

Limit Clause 9.1.3The character error rate shall be  $\leq 4\%$





Product Service

## **2.13 INTERFACE REJECTION AND BLOCKING IMMUNITY**

### **2.13.1 Specification Reference**

IEC 61097-6, Clause 9.2

### **2.13.2 Equipment Under Test and Modification State**

SAILOR 6390 Navtex receiver S/N: 65700635240029 - Modification State 0

### **2.13.3 Date of Test**

26 August 2013

### **2.13.4 Test Equipment Used**

The major items of test equipment used for the above tests are identified in Section 3.1.

### **2.13.5 Environmental Conditions**

Ambient Temperature	25.4°C
Relative Humidity	38.3%

### **2.13.6 Test Results**

The test system was set up as described in section 1.8. The level was adjusted to +6 dB relative of the STS level. The unwanted signal was generated using a signal generator (SG1) at the frequencies described by the table below. For each interfering frequency range specified, the frequency closest to the wanted frequency was chosen unless otherwise stated.



Navtex – Receive Antenna Type A

24.0 V DC Supply

Receive Frequency (kHz)	Interfering Frequency Range	Interfering Signal Level (relative to wanted level, dB)	Chosen Interference Frequency (MHz)	Character Error Rate (%)
490.0	489 kHz to 489.5 kHz	+20	489.5 kHz	0 (No Errors)
	490.5 kHz to 491 kHz	+20	490.5 kHz	0 (No Errors)
	487 kHz to 489 kHz	+40	489.0 kHz	0 (No Errors)
	491 kHz to 493 kHz	+40	491.0 kHz	0 (No Errors)
	100 kHz to 487 kHz	+70	245.0 kHz <sup>1</sup>	0 (No Errors)
	100 kHz to 487 kHz	+70	163.333 kHz <sup>2</sup>	0 (No Errors)
	493 kHz to 30 MHz	+70	493.0 kHz	0 (No Errors)
	156 MHz to 174 MHz	+70	156.8 MHz <sup>3</sup>	0 (No Errors)
	450 MHz to 470 MHz	+70	450.0 MHz	0 (No Errors)
518.0	517 kHz to 517.5 kHz	+20	517.5 kHz	0 (No Errors)
	518.5 kHz to 519 kHz	+20	519.0 kHz	0 (No Errors)
	515 kHz to 517 kHz	+40	517.0 kHz	0 (No Errors)
	519 kHz to 521 kHz	+40	519.0 kHz	0 (No Errors)
	100 kHz to 515 kHz	+70	259.0 kHz <sup>1</sup>	0 (No Errors)
	100 kHz to 515 kHz	+70	172.666 kHz <sup>2</sup>	0 (No Errors)
	521 kHz to 30 MHz	+70	521.0 kHz	0 (No Errors)
	156 MHz to 174 MHz	+70	156.8 MHz <sup>3</sup>	0 (No Errors)
	450 MHz to 470 MHz	+70	450.0 MHz	0 (No Errors)
4209.5	4208.5 kHz to 4209 kHz	+20	4209.0 kHz	0 (No Errors)
	4210 kHz to 4210.5 kHz	+20	4210.0 kHz	0 (No Errors)
	4206.5 kHz to 4208.5 kHz	+40	4208.5 kHz	0 (No Errors)
	4210.5 kHz to 4212.5 kHz	+40	4210.5 kHz	0 (No Errors)
	100 kHz to 4206.5 kHz	+70	450.0 kHz <sup>4</sup>	0 (No Errors)
	100 kHz to 4206.5 kHz	+70	3309.5 kHz <sup>5</sup>	0 (No Errors)
	4212.5 kHz to 30 MHz	+70	4212.5 kHz	0 (No Errors)
	156 MHz to 174 MHz	+70	156.8 MHz <sup>3</sup>	0 (No Errors)
	450 MHz to 470 MHz	+70	450.0 MHz	0 (No Errors)

<sup>1</sup>  $f_{sp} = 1/2 \cdot f_{rx}$  - To ensure 2<sup>nd</sup> harmonic is not generated in the receiver.  
<sup>2</sup>  $f_{sp} = 1/3 \cdot f_{rx}$  - To ensure 3<sup>rd</sup> harmonic is not generated in the receiver.  
<sup>1 & 2</sup> Suppression filter was used with  $f_c = 250$  kHz.

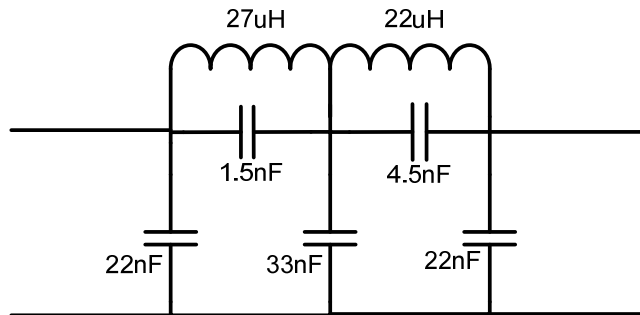

Circuit Diagram of 250 kHz Low Pass Filter

<sup>3</sup> Frequency of the maritime emergency channel – channel 16.

<sup>4</sup>  $f_{IF} = 450 \text{ kHz}$

<sup>5</sup>  $f_{IM} = f_{rx} - 2 \cdot f_{IF}$

Limit Clause 9.2.3

The unwanted signal shall not induce a character error rate >4% in any of the received messages.



Product Service

## 2.14 CO-CHANNEL REJECTION

### 2.14.1 Specification Reference

IEC 61097-6, Clause 9.3

### 2.14.2 Equipment Under Test and Modification State

SAILOR 6390 Navtex receiver S/N: 65700635240029 - Modification State 0

### 2.14.3 Date of Test

27 August 2013

### 2.14.4 Test Equipment Used

The major items of test equipment used for the above tests are identified in Section 3.1.

### 2.14.5 Environmental Conditions

Ambient Temperature 25.7°C  
Relative Humidity 45.1%

### 2.14.6 Test Results

The test system was set up as described in section 1.8. The level was adjusted to +6 dB relative of the STS level. The unwanted signal was generated using a signal generator (SG1) at the receive frequencies described by the table below at a level corresponding to -6 dB of the STS.

#### Navtex – Receive Antenna Type A

24.0 V DC Supply

Receive Frequency (kHz)	Character Error Rate (%)
490.0	0 (No errors)
518.0	0 (No errors)
4290.5	0 (No errors)

#### Limit Clause 9.3.3

The unwanted signal shall not induce a character error rate >4% in any of the received messages.



Product Service

## 2.15 INTERMODULATION

### 2.15.1 Specification Reference

IEC 61097-6, Clause 9.4

### 2.15.2 Equipment Under Test and Modification State

SAILOR 6390 Navtex receiver S/N: 65700635240029 - Modification State 0

### 2.15.3 Date of Test

27 August 2013

### 2.15.4 Test Equipment Used

The major items of test equipment used for the above tests are identified in Section 3.1.

### 2.15.5 Environmental Conditions

Ambient Temperature	25.0°C
Relative Humidity	49.2%

### 2.15.6 Test Results

The test system was set up as described in section 1.8. The level was adjusted to +6 dB relative of the STS level. The unwanted signals were generated using two signal generators (SG1 and SG2) at the receive frequencies described by the table below at a level corresponding to +50 dB relative to the wanted signal (-51 dBm).



Product Service

Navtex – Receive Antenna Type A

24 V DC Supply

Receive Frequency (kHz)	Intermodulation Frequency Pair (kHz)		Character Error Rate (%)
490.0	488.0	486.0	0 (No Errors)
	487.0	484.0	0 (No Errors)
	486.0	482.0	0 (No Errors)
	492.0	494.0	0 (No Errors)
	493.0	496.0	0 (No Errors)
	494.0	498.0	0 (No Errors)
518.0	516.0	514.0	0 (No Errors)
	515.0	512.0	0 (No Errors)
	514.0	510.0	0 (No Errors)
	520.0	522.0	0 (No Errors)
	521.0	524.0	0 (No Errors)
	522.0	526.0	0 (No Errors)
4209.5	4207.5	4205.5	0 (No Errors)
	4206.5	4203.5	0 (No Errors)
	4205.5	4201.5	0 (No Errors)
	4211.5	4213.5	0 (No Errors)
	4212.5	4215.5	0 (No Errors)
	4213.5	4217.5	0 (No Errors)

Limit Clause 9.4.3

Intermodulation shall not induce a character error rate >4%.



Product Service

**2.16 OFF-FREQUENCY TRANSMITTER****2.16.1 Specification Reference**

IEC 61097-6, Clause 9.5

**2.16.2 Equipment Under Test and Modification State**

SAILOR 6390 Navtex receiver S/N: 65700635240029 - Modification State 0

**2.16.3 Date of Test**

27 August 2013

**2.16.4 Test Equipment Used**

The major items of test equipment used for the above tests are identified in Section 3.1.

**2.16.5 Environmental Conditions**

Ambient Temperature 25.2°C

Relative Humidity 49.1%

**2.16.6 Test Results**

The test system was set up as described in section 1.8. The level was adjusted to +6 dB relative of the STS level with a frequency offset of  $\pm 25$  Hz as described in the table below.

Navtex – Receive Antenna Type A

24.0 V DC Supply

Receive Frequency (kHz)	Frequency Shift (Hz)	Character Error Rate (%)
490.0	-25	0 (No Errors)
	+25	0 (No Errors)
518.0	-25	0 (No Errors)
	+25	0 (No Errors)
4209.5	-25	0 (No Errors)
	+25	0 (No Errors)

Limit Clause 9.5.3

The test signal shall not produce in the EUT a character error rate >4% for each test.



Product Service

**2.17 SIMULTANEOUS OPERATION ON SEVERAL RECEIVE FREQUENCIES**

**2.17.1 Specification Reference**

IEC 61097-6, Clause 9.6

**2.17.2 Equipment Under Test and Modification State**

SAILOR 6390 Navtex receiver S/N: 65700635240029 - Modification State 0

**2.17.3 Date of Test**

27 August 2013

**2.17.4 Test Equipment Used**

The major items of test equipment used for the above tests are identified in Section 3.1.

**2.17.5 Environmental Conditions**

Ambient Temperature 25.2°C  
Relative Humidity 42.7%

**2.17.6 Test Results**

The test system was set up as described in section 1.8. SG3 and SG4 were used to provide the STS. The signal generators were adjusted to the frequency and amplitude at the receiver input of the EUT as described by the table below.

Navtex – Receive Antenna Type A

24.0 V DC Supply

STS 1			STS 2		
Receive Frequency (kHz)	Amplitude (dBm)	Character Error Rate (%)	Receive Frequency (kHz)	Amplitude (dBm)	Character Error Rate (%)
490.0	-101	0 (No Errors)	518.0	-51	0 (No Errors)
490.0	-51	0 (No Errors)	518.0	-101	0 (No Errors)
490.0	-101	0 (No Errors)	4209.5	-51	0 (No Errors)
490.0	-51	0 (No Errors)	4209.5	-101	0 (No Errors)
518.0	-101	0 (No Errors)	4209.5	-51	0 (No Errors)
518.0	-51	0 (No Errors)	4209.5	-101	0 (No Errors)

Limit Clause 9.6.3

The display of the STS transmitted on each frequency shall have a character error rate of ≤4%.





## 2.18 PROTECTION OF INPUT CIRCUITS

### 2.18.1 Specification Reference

IEC 61097-6, Clause 9.7

### 2.18.2 Equipment Under Test and Modification State

SAILOR 6390 Navtex receiver S/N: 65700635240029 - Modification State 0

### 2.18.3 Date of Test

27 August 2013

### 2.18.4 Test Equipment Used

The major items of test equipment used for the above tests are identified in Section 3.1.

### 2.18.5 Environmental Conditions

Ambient Temperature	26.1°C
Relative Humidity	40.9%

### 2.18.6 Test Results

A signal generator at a frequency described by the table below was connected to the input of a RF amplifier. The output of the RF amplifier was connected to a DSO via 36 dB of external attenuation to protect the input of the test equipment. The gain was adjusted on the RF amplifier until a level of  $1.34 V_{pp}$  was observed on the DSO. When 30 dB of external attenuation is removed, this level corresponds to a level of  $15 V_{rms}$  with matched load equivalent to  $30 V_{rms}$  (E.M.F).

#### Calibration Setup Diagram

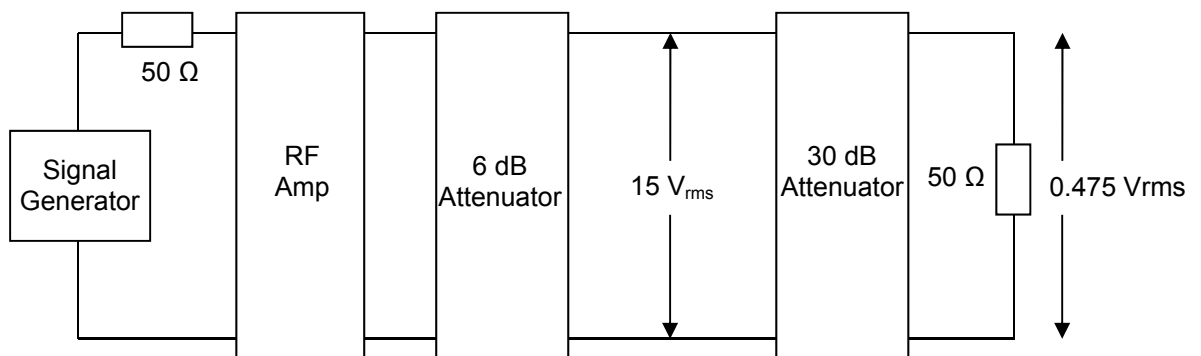



Product Service

A level of  $30V_{rms}$  (E.M.F) is applied to the receiver input for duration of 15 minutes after which a performance check was performed on each frequency as described by the table below. The wanted test signal was set up as described in 1.8. The signal generator amplitude was set relative to +6 dB of the STS level and the message sent to the EUT repeated 25 times on each of the frequencies as described by the table below (One frequency for each receiver).

The test frequency was adjusted and the above step was performed again.

#### Navtex – Receive Antenna Type A

##### 24.0 V DC Supply

Chosen Test Frequency (kHz)	Test Level (Vrms)	Test Time (Minutes)	Result		
			490.0 kHz	518.0 kHz	4209.5 kHz
518.0	30	15	0 (No Errors)	0 (No Errors)	0 (No Errors)
4209.5	30	15	0 (No Errors)	0 (No Errors)	0 (No Errors)

#### Limit Clause 9.7.3

The EUT shall continue to operate normally.



Product Service

**2.19 TESTS OF TECHNICAL CHARACTERISTICS (ITU-RECOMMENDATION M.540)**

**2.19.1 Specification Reference**

IEC 61097-6, Clause 10.5

**2.19.2 Equipment Under Test and Modification State**

SAILOR 6390 Navtex receiver S/N: 65700635240029 - Modification State 2

**2.19.3 Date of Test**

30 August 2013 – 02 September 2013

**2.19.4 Test Equipment Used**

The major items of test equipment used for the above tests are identified in Section 3.1.

**2.19.5 Environmental Conditions**

Ambient Temperature 23.8 - 24.0°C  
Relative Humidity 52.3 - 54.0%

**2.19.6 Test Results**

Navtex - Receiver

24.0 V DC Supply

Printer activation/error-free preamble B<sub>1</sub>-B<sub>4</sub>

	Result: 490.0 kHz	Result: 518.0 kHz	Result: 4209.5 kHz
Please confirm the EUT does not store message identifications nor print out the messages with the EUT configured to accept all B <sub>1</sub> and B <sub>2</sub> characters.	Pass – No messages received.	Pass – No messages received.	Pass – No messages received.
Please confirm the EUT does not store message identifications nor print out the messages with the EUT configured to accept specific B <sub>1</sub> and B <sub>2</sub> characters.	Pass – The EUT was configured to accept messages with B <sub>1</sub> = A B G H I J. No messages received.	Pass – The EUT was configured to accept messages with B <sub>1</sub> = A B G H I J. No messages received.	Pass – The EUT was configured to accept messages with B <sub>1</sub> = A B G H I J. No messages received.

Limit Clause 10.5.2.2

The EUT shall neither store the message identifications nor print out the messages.



Product Service

Non-repetitive printing of a message

IEC 61097-6 Clause 11.3 is only required for EUT's with an integral printer therefore 11.3 was not required. The method detailed in 11.3.1 was used to demonstrate conformance with clause 4.3.4 Repetition of printing/display. As this is not a test of the EUT's memory capability the method was adjusted as to not wait the 59 h, 2 h & 12 h specified. Conformance of the EUT's memory capability is proven by conformance with clause 11.2, see section 2.43.

	Result: 490.0 kHz	Result: 518.0 kHz	Result: 4209.5 kHz
Please confirm the EUT does not store repeated message identifications nor print out the messages.	Pass	Pass	Pass

Limit Clause 10.5.2.3

The EUT shall neither store the message identifications nor print out the messages.

Message with B<sub>3</sub>B<sub>4</sub> = 00

	Result: 490.0 kHz	Result: 518.0 kHz	Result: 4209.5 kHz
Please confirm the EUT always prints, stores and displays the test message when transmitted with B <sub>1</sub> selected.	Pass	Pass	Pass

Limit Clause 10.5.4.2

The EUT shall always print, store and display the test message when transmitted with B<sub>1</sub> selected.



Product Service

## **2.20 INTERNAL STORAGE, MESSAGE TAGGING AND ERASURE OF OLDEST MESSAGE IDENTIFICATION**

### **2.20.1 Specification Reference**

IEC 61097-6, Clause 11.1

### **2.20.2 Equipment Under Test and Modification State**

SAILOR 6390 Navtex receiver S/N: 65700635240029 - Modification State 2

### **2.20.3 Date of Test**

02 September 2013

### **2.20.4 Test Equipment Used**

The major items of test equipment used for the above tests are identified in Section 3.1.

### **2.20.5 Environmental Conditions**

Ambient Temperature	24.5°C
Relative Humidity	49.9%

### **2.20.6 Test Results**

The STF was pre-loaded in to the non-volatile memory of the EUT. This file contained 6000 messages (2000 for each receive frequency) each 500 characters in length.

The 5 oldest messages were tagged for permanent retention and the database file was logged for comparison. The test script consisting of 10 new messages was sent and the database file was again logged. All messages were untagged and a further 10 new messages was sent. The database file was again logged for comparison. This was repeated for all 3 receive frequencies as per the table below:

Navtex - Receiver

## 24.0 V DC Supply

Requirement	Results		
	490.0 kHz	518.0 kHz	4209.5 kHz
a) Storage of all messages of the STF	✓	✓	✓
b) Tagging of five oldest messages	✓	✓	✓
c) Test script messages stored at end of messages, tagged messages still stored and next oldest 10 messages are no longer stored.	✓	✓	✓
d) All tagged messages were untagged. Ten oldest messages replaced by ten new messages from test script.	✓	✓	✓

Limit Clause 11.1.2

- a) A check of the EUT shall indicate that all messages of the STF have been stored.
- b) The EUT shall be checked to ensure it has correctly tagged the messages.
- c) A check of the EUT shall indicate that all messages of the test script have been stored, that the first (oldest) 5 tagged messages are still stored and that the next 10 oldest messages of the STF are no longer stored.
- d) A check of the EUT shall indicate that the 10 oldest messages have been replaced by the 10 new messages.



Product Service

**2.21 ERASURE OF MESSAGE IDENTIFICATIONS / STORAGE TIME**

**2.21.1 Specification Reference**

IEC 61097-6, Clause 11.2

**2.21.2 Equipment Under Test and Modification State**

SAILOR 6390 Navtex receiver S/N: 65700635240027 - Modification State 0

**2.21.3 Date of Test**

21 August 2013

**2.21.4 Test Equipment Used**

The major items of test equipment used for the above tests are identified in Section 3.1.

**2.21.5 Environmental Conditions**

Ambient Temperature 22.5 °C  
Relative Humidity 41.9 %

**2.21.6 Test Results**

24.0 V DC Supply

Requirement	Results		
	490.0 kHz	518.0 kHz	4209.5 kHz
a) Non storage of new message	N/A*	✓	N/A*
a) Non overwriting of any stored contents		✓	
b) 61 hour message 'A' stored		✓	
b) 61 hour message overwrote oldest message		✓	
c) 73 hour check that only message 'A' & tagged message are stored		✓	
d) Storage of test script & tagged message		✓	

Limit Clause 11.2.2

- a) A check of the EUT shall indicate that the message applied after 59 hours was not stored and did not overwrite any of the stored contents of the EUT.
- b) A check of the EUT shall indicate that the message 'A' applied after 61 hours was stored and overwrote the oldest message stored in the EUT.
- c) A check of the EUT after 73 hours shall indicate that only message 'A' and the message tagged for retention are stored in the EUT.
- d) After applying the test script the EUT shall contain the contents of the test script, and the message tagged for retention.

\*The memory store is one database that applies to all frequencies.



Product Service

## **2.22 RECEPTION OF MESSAGES WITH CHARACTER ERRORS**

### **2.22.1 Specification Reference**

IEC 61097-6, Clause 11.4

### **2.22.2 Equipment Under Test and Modification State**

SAILOR 6390 Navtex receiver S/N: 65700635240029 - Modification State 2

### **2.22.3 Date of Test**

02 September 2013

### **2.22.4 Test Equipment Used**

The major items of test equipment used for the above tests are identified in Section 3.1.

### **2.22.5 Environmental Conditions**

Ambient Temperature	24.2°C
Relative Humidity	51.4%

### **2.22.6 Test Results**

The STS was applied to the EUT with modified messages to contain a character error rate (CER) >20% and < 33%. The STS was repeated 35 times. It was observed that the EUT stored in memory and printed the 35 messages, each indicating a CER of >20% and < 33%.

The message contents was modified further to give a CER >4 % and < 20%. The STS was applied to the EUT a further 35 times and it was observed that the EUT stored in memory and printed the 35 messages, each indicating a CER of >4 % and < 20%.



Navtex - Receiver

## 24.0 V DC Supply

Frequency – 490.0 kHz	
Conditions	Result
a) 35 messages with CER at 27 %	All messages stored & printed indicating a character error rate of 27 %.
b) 35 messages with CER at 11 %	All messages stored & printed indicating a character error rate of 11 %.
Frequency – 518.0 kHz	
Conditions	Result
a) 35 messages with CER at 27 %	All messages stored & printed indicating a character error rate of 27 %.
b) 35 messages with CER at 11 %	All messages stored & printed indicating a character error rate of 11 %.
Frequency – 4209.5 kHz	
Conditions	Result
a) 35 messages with CER at 27 %	All messages stored & printed indicating a character error rate of 27 %.
b) 35 messages with CER at 10 %	All messages stored & printed indicating a character error rate of 10 %.

Limit Clause 11.4.2

- a) The EUT shall store (non-printing EUTs) or print (printing EUTs) the 35 messages, each indicating the character error rate of >20% and ≤33%.
- b) The EUT shall store (non-printing EUTs) or print (printing EUTs) the 35 messages, each indicating the character error rate of >4% and ≤20%.



Product Service

**2.23 UNSATISFACTORY RECEPTION**

**2.23.1 Specification Reference**

IEC 61097-6, Clause 11.5

**2.23.2 Equipment Under Test and Modification State**

SAILOR 6390 Navtex receiver S/N: 65700635240029 - Modification State 2

**2.23.3 Date of Test**

02 September 2013

**2.23.4 Test Equipment Used**

The major items of test equipment used for the above tests are identified in Section 3.1.

**2.23.5 Environmental Conditions**

Ambient Temperature 24.3°C  
Relative Humidity 49.9%

**2.23.6 Test Results**

The STS was applied to the EUT with modified messages to contain a character error rate (CER) >33%. The STS was repeated 35 times. It was observed that EUT did not store in memory or print any of the 35 messages.

Navtex - Receiver

24.0 V DC Supply

Conditions	Result – 490.0 kHz	Result – 518.0 kHz	Result – 4209.5 kHz
35 messages with correct ID and CER > 33%.	No messages stored or displayed.	No messages stored or displayed.	No messages stored or displayed.

Limit Clause 11.5.2

The EUT shall not store messages or message identifications. An EUT with an integral printer shall not print any of the test messages.



Product Service

**2.24 POWER-OFF CHECK****2.24.1 Specification Reference**

IEC 61097-6, Clause 11.6

**2.24.2 Equipment Under Test and Modification State**

SAILOR 6390 Navtex receiver S/N: 65700635240029 - Modification State 2

**2.24.3 Date of Test**

03 September 2013

**2.24.4 Test Equipment Used**

The major items of test equipment used for the above tests are identified in Section 3.1.

**2.24.5 Environmental Conditions**

Ambient Temperature 24.8°C

Relative Humidity 51.6%

**2.24.6 Test Results**

The STF was pre-loaded in to the EUT and the database file was logged for comparison. The current B<sub>1</sub> and B<sub>2</sub> characters were noted. Power was removed from the equipment for a period > 6 h after which power was re-applied to the EUT. The contents of the database file were logged for comparison. The current B<sub>1</sub> and B<sub>2</sub> characters were examined for any change.

Navtex - Receiver

24.0 V DC Supply

Requirement	Results after six hours power-off		
	490.0 kHz	518.0 kHz	4209.5 kHz
Contents of non-volatile message storage	✓	✓	✓
Settings for transmitter coverage area (B <sub>1</sub> )	✓	✓	✓
Settings for message type (B <sub>2</sub> )	✓	✓	✓
Other non volatile user settings	None	None	None

Limit Clause 11.6.2

After a 6 hour power-down cycle, the EUT's non-volatile message storage shall contain the set of messages defined in the STF. All settings that the manufacturer has declared as non-volatile shall be unchanged from before the power-off cycle.



Product Service

**2.25 BROWN-OUT TEST**

**2.25.1 Specification Reference**

IEC 61097-6, Clause 11.7

**2.25.2 Equipment Under Test and Modification State**

SAILOR 6390 Navtex receiver S/N: 65700635240029 - Modification State 2

**2.25.3 Date of Test**

03 September 2013

**2.25.4 Test Equipment Used**

The major items of test equipment used for the above tests are identified in Section 3.1.

**2.25.5 Environmental Conditions**

Ambient Temperature 24.8°C  
 Relative Humidity 51.6%

**2.25.6 Test Results**

The STF was pre-loaded in to the EUT and the database file was logged for comparison. The current B<sub>1</sub> and B<sub>2</sub> characters were noted. The supply voltage was gradually decreased from nominal voltage (12.0 V) to 40% of nominal voltage (4.8 V) over a time period of 30 s. After which, the voltage was gradually increased from 40% of nominal voltage (4.8 V) to 80% of nominal voltage (9.6 V) over a time period of 30 s. The contents of the database file was logged after the “brown out” condition and logged for comparison. The current B<sub>1</sub> and B<sub>2</sub> characters were examined for any change.

Navtex - Receiver

12.0 V DC Supply (Minimum voltage was used as this would result in worst case conditions).

Requirement	Results after brown-out		
	490.0 kHz	518.0 kHz	4209.5 kHz
Contents of non-volatile message storage	✓	✓	✓
Settings for transmitter coverage area (B <sub>1</sub> )	✓	✓	✓
Settings for message type (B <sub>2</sub> )	✓	✓	✓
Declared non volatile settings unchanged	None	None	None

Limit Clause 11.7.2

After a power supply brown-out, the EUT’s non-volatile message storage shall contain the set of messages defined in the STF. All settings that the manufacturer has declared as non-volatile shall be unchanged from before the power-off cycle.



Product Service

**2.26 UTC HANDLING CHECK****2.26.1 Specification Reference**

IEC 61097-6, Clause 11.8

**2.26.2 Equipment Under Test and Modification State**

SAILOR 6390 Navtex receiver S/N: 65700635240027 - Modification State 0

**2.26.3 Date of Test**

17 October 2013

**2.26.4 Test Equipment Used**

The major items of test equipment used for the above tests are identified in Section 3.1.

**2.26.5 Environmental Conditions**

Ambient Temperature    22.7 °C  
 Relative Humidity        44.5 %

**2.26.6 Test Results**Navtex - Receiver

24.0 V DC Supply

Requirement	Results after six hours power-off
Memory contents check after 6 hours power-down	Memory contents have not changed
Memory contents check after a further 53 hours power on	Memory contents have not changed

Limit Clause 11.8.2

After a 6 hour power-down cycle, the EUT's non-volatile message storage shall contain the set of messages defined in the STF. After a further 53 hours power on, the memory contents shall not have changed.



Product Service

**2.27 SPURIOUS EMISSIONS**

**2.27.1 Specification Reference**

IEC 61097-6, Clause 12.1

**2.27.2 Equipment Under Test and Modification State**

SAILOR 6390 Navtex receiver S/N: 65700635240029 - Modification State 0

**2.27.3 Date of Test**

27 August 2013

**2.27.4 Test Equipment Used**

The major items of test equipment used for the above tests are identified in Section 3.1.

**2.27.5 Environmental Conditions**

Ambient Temperature 25.6°C  
 Relative Humidity 49.1%

**2.27.6 Test Results**

The receiver input of the EUT was connected to the output of the spectrum analyser via a DC block. The loss between the EUT and the spectrum analyser was measured using a spectrum analyser with tracking generator function. The worst case loss over the frequency range 9 kHz – 2 GHz was < 1dB therefore was considered negligible providing a 6 dB Pass margin was obtained.

Navtex - Receiver Type A

24.0 V DC Supply

Frequency (kHz)	Level (nW)
9 kHz – 2 GHz	< 1 nW*

\*No spurious emissions were detected within 6dB of the limit.

Limit Clause 12.1.2

The power of any discrete component shall be  $\leq 1 \times 10^{-9}$  W (1nW).



Product Service

## 2.28 EQUIPMENT MANUALS

### 2.28.1 Specification Reference

IEC 61097-6, Clause 12.2

### 2.28.2 Equipment Under Test and Modification State

SAILOR 6390 Navtex receiver S/N: 65700635240027 - Modification State 2

### 2.28.3 Date of Test

16 October 2013

### 2.28.4 Test Equipment Used

No test equipment was required.

### 2.28.5 Test Results

The EUT shall comply with the requirements of IEC 60945 Clause 4.8 which are as follows.

#### **Requirements of IEC 60945 Clause 4.8**

*“Adequate information shall be provided to enable the equipment to be properly operated and maintained by suitably qualified members of a ship’s crew.”*

The manual describes the operation and maintenance of the equipment.

a) *be written in English;*

The manual is written in English.

b) *identify the category of the equipment or units to which they refer (4.4);*

The equipment is identified as for use in a protected environment and this is written in the Installation and service section at the beginning of the manual.

c) *(A.694/8.3.1) in the case of equipment so designed that fault diagnosis and repair down to component level are practicable, provide full circuit diagrams, component layouts and a component parts list;*

The equipment is not designed to be repaired.

d) *(A.694/8.3.2) in the case of equipment containing complex modules in which fault diagnosis and repair down to component level are not practicable, contain sufficient information to enable a defective complex module to be located, identified and replaced. Other modules and those discrete components which do not form part of modules shall also meet the requirements of 4.8 c) above.*

The equipment is defined as being a single module and will either be operational or faulty.



*Moreover adequate information shall be provided to allow equipment to be installed so that it operates in accordance with the requirements of the relevant equipment standard, taking into account limitations imposed by the operation of other equipment also required to be installed on the bridge.*

The installation manual provides guidance on how to install the equipment including placement of the antenna.

#### **Requirements of IEC 61097-6 Annex D**

Requirement	Section of Manual	Results
nominal supply voltage and frequency	Appendix A - Specifications	Pass
minimum and maximum supply voltage	Appendix A - Specifications	Pass
how the reception and storage of new messages other than SAR messages are indicated to the user	Chapter 2 - Operation	Pass
the memory capacity of the unit in terms of the number of 500 character long messages	Chapter 1 - Introduction	Pass
whether the unit is IEC 60945 'protected' or 'exposed' category	Installation and service	Pass
a list of available alarms	Alarms and notifications	Pass
the receiver frequencies on which the unit operates	Chapter 1 - Introduction	Pass
a list of user settings that are non-volatile	Chapter 1 - Introduction Chapter 2 - Operation	Pass
whether the unit uses a source of time for handling message ageing (for example UTC from an external source or an internal RTC)	Chapter 2 - Operation	Pass
operating temperature range	Appendix A - Specifications	Pass
storage temperature range	Appendix A - Specifications	Pass
INS port serial interface electrical and protocol standards and settings	Chapter 1 - Introduction	Pass
printer port serial interface electrical and protocol standards and settings	Not applicable	Pass
provide an overview of the NAVTEX system	Installation section of installation manual	Pass
manufacturer recommendations, if any, on periodic functional testing and maintenance	Chapter 3 - Service & maintenance	Pass
warranty information	Chapter 1 - Introduction	Pass
a recommendation for mounting the unit	Installation section of installation manual	Pass
information relating to the shipment of the unit	Chapter 3 - Service & maintenance	Pass
information relating to the disposal of the unit at the end of its operational life	Chapter 3 - Service & maintenance	Pass
a list of languages supported by the user interface	Chapter 1 - Introduction	Pass

In addition to the requirements of 61097-6 and IEC 60945, the equipment has been tested to and complies with the requirements of IEC 61162-1, test results are shown in test report 75923004 Report 02.





Product Service

**2.29 MARKING AND IDENTIFICATION**

**2.29.1 Specification Reference**

IEC 61097-6, Clause 12.3

**2.29.2 Equipment Under Test and Modification State**

SAILOR 6390 Navtex receiver S/N: 65700635240029 - Modification State 2

**2.29.3 Date of Test**

02 September 2013

**2.29.4 Environmental Conditions**

Ambient Temperature	23.8°C
Relative Humidity	52.1%

**2.29.5 Test Results**

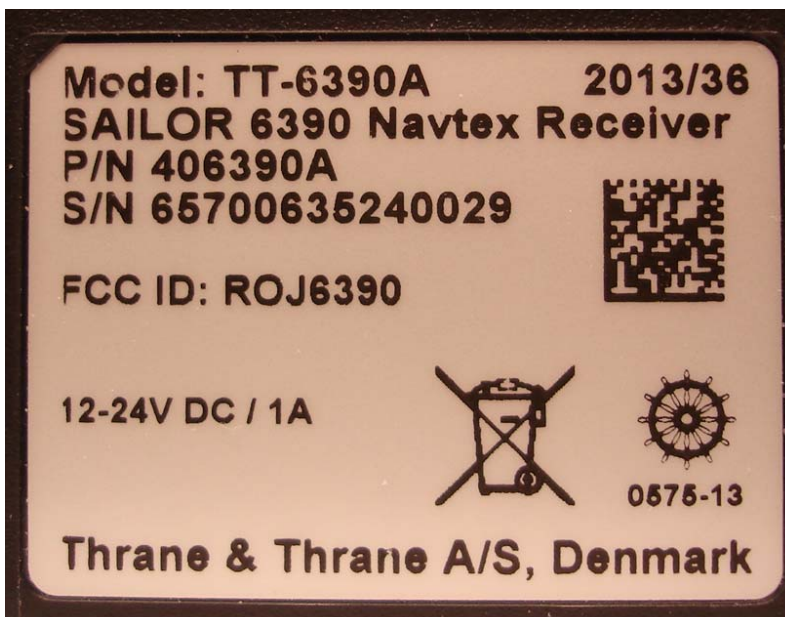
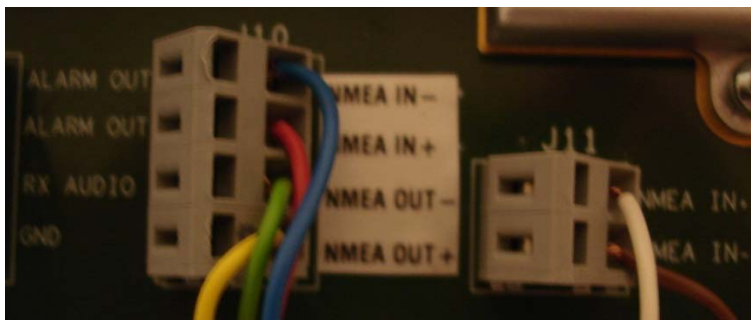



Product Service

Limit Clause 12.3

The markings on the EUT shall include details of the power supply from which the equipment is intended to be operated as well as those specified in 4.9 of IEC 60945.

The interface connections required shall be clearly identified in the operator manual or other appropriate literature. This shall include identification of A and B signal lines for IEC 61162 interfaces.



Product Service

### **SECTION 3**

#### **TEST EQUIPMENT USED**



Product Service

**3.1 TEST EQUIPMENT USED**

List of absolute measuring and other principal items of test equipment.

Instrument	Manufacturer	Type No.	Serial Number	Calibration Period (months)	Calibration Due
<b>Section 2.1 – INS Input Electrical</b>					
Hygrometer	Rotronic	I-1000	TE: 1386	12	18-Apr-2014
Multimeter	Iso-Tech	IDM101	TE 2419	12	09-Oct-2014
Multimeter	Iso-Tech	IDM101	TE 2424	12	12-Sep-2014
Power Supply Unit	Hewlett Packard	6253A	TE 0084	-	O/P Mon
<b>Section 2.2 – INS Input Performance</b>					
Hygrometer	Rotronic	I-1000	TE: 1386	12	18-Apr-2014
Power Supply	Iso-Tech	IPS 2010	TE: 2435	-	OP MON
Multimeter	Iso-Tech	IDM101	TE: 2419	12	09-Oct-2014
USB to Serial	Brainboxes	US-842	24172	-	TU
<b>Section 2.3 – INS Output Electrical</b>					
Multimeter	Iso-tech	IDM101	TE:2421	12	25-Oct-2013
Hygrometer	R.S Components	1361C	TE: 3844	12	22-Mar-2014
Power Supply Unit	EA	EA-3023	ECI 5670	-	O/P Mon
Power Supply Unit	Agilent	E3620A	TT12133	-	O/P Mon
Oscilloscope	Hewlett Packard	54602B	ECI 4649	24	06-Jun-2015
<b>Section 2.4 – INS Output Performance</b>					
Multimeter	Iso-tech	IDM101	TE:2421	12	25-Oct-2013
Hygrometer	R.S Components	1361C	TE: 3844	12	22-Mar-2014
DC Power Supply	Bang & Ouesen	SN17	ECI 3174	-	O/P Mon
Signal Generator	Marconi Instruments	2024	TT12108 / 112246/014	12	26-Oct-2013
Signal Generator	IFN	2025	TT12109 / 202303/587	12	26-Oct-2013
Navtex Test Modem	ICS V4 Navtex Modem	N/a	TTA00244	-	TU
Power Splitter	Mini Circuits	ZSC-2-1	B UU05401239	-	TU
Power Splitter	Mini Circuits	ZSC-2-1	B UU05401239	-	TU
Spectrum Analyser	Rohde & Schwarz	FSEA	ECI 6943 / 833608	6	13-Sep-2013
10 MHz Frequency Reference	Hewlett Packard	58503B	ECI 6960	-	TU



Instrument	Manufacturer	Type No.	Serial Number	Calibration Period (months)	Calibration Due
<b>Section 2.6 – Printer Output Performance</b>					
Multimeter	Iso-tech	IDM101	TE 2421	12	25-Oct-2013
Hygrometer	R.S Components	1361C	TE 3844	12	22-Mar-2014
DC Power Supply	Bang & Ouesen	SN17	ECI 3174	-	O/P Mon
Signal Generator	Marconi Instruments	2024	TT12108 / 112246/014	12	26-Oct-2013
Signal Generator	IFN	2025	TT12109 / 202303/587	12	26-Oct-2013
Navtex Test Modem	ICS V4 Navtex Modem	N/A	TTA00244	-	TU
Power Splitter	Mini Circuits	ZSC-2-1	B UU05401239	-	TU
Power Splitter	Mini Circuits	ZSC-2-1	B UU05401239	-	TU
Spectrum Analyser	Rohde & Schwarz	FSEA	ECI 6943 / 833608	6	13-Sep-2013
10 MHz Frequency Reference	Hewlett Packard	58503B	ECI 6960	-	TU
<b>Section 2.7 – Exclusion of Stations</b>					
Multimeter	Iso-tech	IDM101	TE 2421	12	25-Oct-2013
Hygrometer	R.S Components	1361C	TE 3844	12	22-Mar-2014
DC Power Supply	Bang & Ouesen	SN17	ECI 3174	-	O/P Mon
Signal Generator	Marconi Instruments	2024	TT12108 / 112246/014	12	26-Oct-2013
Signal Generator	IFN	2025	TT12109 / 202303/587	12	26-Oct-2013
2 Navtex Test Modems (Same ID)	ICS	V4 Navtex Modem	TTA00244	-	TU
Power Splitter	Mini Circuits	ZSC-2-1	B UU05401239	-	TU
Power Splitter	Mini Circuits	ZSC-2-1	B UU05401239	-	TU
Spectrum Analyser	Rohde & Schwarz	FSEA	ECI 6943 / 833608	6	13-Sep-2013
10 MHz Frequency Reference	Hewlett Packard	58503B	ECI 6960	-	TU
<b>Section 2.8– Exclusion of Message Categories</b>					
Multimeter	Iso-tech	IDM101	TE 2421	12	25-Oct-2013
Hygrometer	R.S Components	1361C	TE 3844	12	22-Mar-2014
DC Power Supply	Bang & Ouesen	SN17	ECI 3174	-	O/P Mon
Signal Generator	Marconi Instruments	2024	TT12108 / 112246/014	12	26-Oct-2013
Signal Generator	IFN	2025	TT12109 / 202303/587	12	26-Oct-2013
2 Navtex Test Modems (Same ID)	ICS	V4 Navtex Modem	TTA00244	-	TU
Power Splitter	Mini Circuits	ZSC-2-1	B UU05401239	-	TU
Power Splitter	Mini Circuits	ZSC-2-1	B UU05401239	-	TU
Spectrum Analyser	Rohde & Schwarz	FSEA	ECI 6943 / 833608	6	13-Sep-2013
10 MHz Frequency Reference	Hewlett Packard	58503B	ECI 6960	-	TU



Instrument	Manufacturer	Type No.	Serial Number	Calibration Period (months)	Calibration Due
<b>Section 2.9 – Receiver Test Facility</b>					
Hygrometer	Rotronic	I-1000	TE 1386	12	18-Apr-2014
<b>Section 2.10 – Search and Rescue Alarm Provision and Reset</b>					
Power Supply	Iso-Tech	IPS 2010	TE 2435	-	O/P Mon
Multimeter	Iso-Tech	IDM101	TE 2419	12	09-Oct-2014
Signal Generator	Ifr	2023B	202304/933	-	O/P Mon
Modem	ICS	V4	103596	-	TU
USB to Serial	Brainboxes	US-842	24172	-	TU
<b>Section 2.11 – Additional Alarms</b>					
Power Supply	Iso-Tech	IPS 2010	TE 2435	-	O/P Mon
Multimeter	Iso-Tech	IDM101	TE 2419	12	09-Oct-2014
Signal Generator	Ifr	2023B	202304/933	-	O/P Mon
Modem	ICS	V4	103596	-	TU
USB to Serial	Brainboxes	US-842	24172	-	TU
<b>Section 2.12 – Call Sensitivity</b>					
Multimeter	Iso-tech	IDM101	TE 2421	12	25-Oct-2013
Hygrometer	R.S Components	1361C	TE 3844	12	22-Mar-2014
DC Power Supply	Bang & Ouesen	SN17	ECI 3174	-	O/P Mon
Signal Generator	Marconi Instruments	2024	TT12108 / 112246/014	12	26-Oct-2013
Signal Generator	IFN	2025	TT12109 / 202303/587	12	26-Oct-2013
Navtex Test Modem	ICS V4 Navtex Modem	N/A	TTA00244	-	TU
Power Splitter	Mini Circuits	ZSC-2-1	B UU05401239	-	TU
Power Splitter	Mini Circuits	ZSC-2-1	B UU05401239	-	TU
Spectrum Analyser	Rohde & Schwarz	FSEA	ECI 6943 / 833608	6	13-Sep-2013
10 MHz Frequency Reference	Hewlett Packard	58503B	ECI 6960	-	TU
<b>Section 2.13 – Interference Rejection and Blocking Immunity</b>					
Multimeter	Iso-tech	IDM101	TE 2421	12	25-Oct-2013
Hygrometer	R.S Components	1361C	TE 3844	12	22-Mar-2014
DC Power Supply	Bang & Ouesen	SN17	ECI 3174	-	O/P Mon
Signal Generator	Marconi Instruments	2024	TT12108 / 112246/014	12	26-Oct-2013
Signal Generator	IFN	2025	TT12109 / 202303/587	12	26-Oct-2013
Signal Generator	Rohde & Schwarz	SMA 100A	TT12175 / 103869-TJ	12	14-Mar-2013
Navtex Test System	ICS V4 Navtex Modem	N/A	TTA00244	-	TU
Power Splitter	Mini Circuits	ZSC-2-1	B UU05401239	-	TU
Power Splitter	Mini Circuits	ZSC-2-1	B UU05401239	-	TU
Power Splitter	Mini Circuits	ZSC-2-1	B UU05401239	-	TU
Spectrum Analyser	Rohde & Schwarz	FSEA	ECI 6943 / 833608	6	13-Sep-2013
10 MHz Frequency Reference	Hewlett Packard	58503B	ECI 6960	-	TU
Suppression Filter	Thrane and Thrance	N/A	N/S	-	TU



Product Service

Instrument	Manufacturer	Type No.	Serial Number	Calibration Period (months)	Calibration Due
<b>Section 2.14 – Co-channel Rejection</b>					
Multimeter	Iso-tech	IDM101	TE:2421	12	25-Oct-2013
Hygrometer	R.S Components	1361C	TE: 3844	12	22-Mar-2014
DC Power Supply	Bang & Ouesen	SN17	ECI 3174	-	O/P Mon
Signal Generator	Marconi Instruments	2024	TT12108 / 112246/014	12	26-Oct-2013
Signal Generator	IFN	2025	TT12109 / 202303/587	12	26-Oct-2013
Signal Generator	Rohde & Schwarz	SMA 100A	TT12175 / 103869-TJ	12	14-Mar-2014
Navtex Test System	ICS	?	TTA00244	-	TU
Power Splitter	Mini Circuits	ZSC-2-1	B UU05401239	-	TU
Power Splitter	Mini Circuits	ZSC-2-1	B UU05401239	-	TU
Power Splitter	Mini Circuits	ZSC-2-1	B UU05401239	-	TU
Spectrum Analyser	Rohde & Schwarz	FSEA	ECI 6943 / 833608	6	13-Sep-2013
10 MHz Frequency Reference	HP	58503B	ECI 6960	-	TU
<b>Section 2.15 – Intermodulation</b>					
Multimeter	Iso-tech	IDM101	TE:2421	12	25-Oct-2013
Hygrometer	R.S Components	1361C	TE: 3844	12	22-Mar-2014
DC Power Supply	Bang & Ouesen	SN17	ECI 3174	-	O/P Mon
Signal Generator	Marconi Instruments	2024	TT12108 / 112246/014	12	26-Oct-2013
Signal Generator	IFN	2025	TT12109 / 202303/587	12	26-Oct-2013
Signal Generator	Rohde & Schwarz	SMA 100A	TT12175 / 103869-TJ	12	14-Mar-2014
Signal Generator	Rohde & Schwarz	SMA 100A	TTA00102 / 103038	12	28-Feb-2014
Navtex Test System	ICS	V4	TTA00244	-	TU
Power Splitter	Mini Circuits	ZSC-2-1	B UU05401239	-	TU
Power Splitter	Mini Circuits	ZSC-2-1	B UU05401239	-	TU
Power Splitter	Mini Circuits	ZSC-2-1	B UU05401239	-	TU
Spectrum Analyser	Rohde & Schwarz	FSEA	ECI 6943 / 833608	6	13-Sep-2013
10 MHz Frequency Reference	HP	58503B	ECI 6960	-	TU



Instrument	Manufacturer	Type No.	Serial Number	Calibration Period (months)	Calibration Due
<b>Section 2.16 – Off Frequency Transmitter</b>					
Multimeter	Iso-tech	IDM101	TE:2421	12	25-Oct-2013
Hygrometer	R.S Components	1361C	TE: 3844	12	22-Mar-2014
DC Power Supply	Bang & Ouesen	SN17	ECI 3174	-	O/P Mon
Signal Generator	Marconi Instruments	2024	TT12108 / 112246/014	12	26-Oct-2013
Signal Generator	IFN	2025	TT12109 / 202303/587	12	26-Oct-2013
Navtex Test System	ICS	?	TTA00244	-	TU
Power Splitter	Mini Circuits	ZSC-2-1	B UU05401239	-	TU
Power Splitter	Mini Circuits	ZSC-2-1	B UU05401239	-	TU
Spectrum Analyser	Rohde & Schwarz	FSEA	ECI 6943 / 833608	6	13-Sep-2013
10 MHz Frequency Reference	HP	58503B	ECI 6960	-	TU
<b>Section 2.17 – Simultaneous Operation on Several Receive Frequencies</b>					
Multimeter	Iso-tech	IDM101	TE:2421	12	25-Oct-2013
Hygrometer	R.S Components	1361C	TE: 3844	12	22-Mar-2014
DC Power Supply	Bang & Ouesen	SN17	ECI 3174	-	O/P Mon
Signal Generator	Marconi Instruments	2024	TT12108 / 112246/014	12	26-Oct-2013
Signal Generator	IFN	2025	TT12109 / 202303/587	12	26-Oct-2013
Navtex Test System	ICS	N/A	TTA00244	-	TU
Power Splitter	Mini Circuits	ZSC-2-1	B UU05401239	-	TU
Power Splitter	Mini Circuits	ZSC-2-1	B UU05401239	-	TU
Spectrum Analyser	Rohde & Schwarz	FSEA	ECI 6943 / 833608	6	13-Sep-2013
10 MHz Frequency Reference	HP	58503B	ECI 6960	-	TU
<b>Section 2.18 – Protection of Input Circuits</b>					
Multimeter	Iso-tech	IDM101	TE:2421	12	25-Oct-2013
Hygrometer	R.S Components	1361C	TE: 3844	12	22-Mar-2014
DC Power Supply	Bang & Ouesen	SN17	ECI 3174	-	O/P Mon
Signal Generator	Marconi Instruments	2024	TT12108 / 112246/014	12	26-Oct-2013
Signal Generator	IFN	2025	TT12109 / 202303/587	12	26-Oct-2013
Navtex Test System	ICS	N/A	TTA00244	-	TU
Power Splitter	Mini Circuits	ZSC-2-1	B UU05401239	-	TU
Power Splitter	Mini Circuits	ZSC-2-1	B UU05401239	-	TU
Spectrum Analyser	Rohde & Schwarz	FSEA	ECI 6943 / 833608	6	13-Sep-2013
10 MHz Frequency Reference	HP	58503B	ECI 6960	-	TU
Digital Storage Oscilloscope	Agilent	DSO-X-3012A	TT12157	-	TU
RF Amplifier	Amplifier Research	75A220	ECI 5617	-	TU
6 dB Attenuator	Narda	765-6	ECI 4186	-	TU
30 dB Attenuator	Narda	776C-30	2535	-	TU





Instrument	Manufacturer	Type No.	Serial Number	Calibration Period (months)	Calibration Due
<b>Section 2.19 – Tests of Technical Characteristics (ITU-R Recommendation M.540)</b>					
Multimeter	Iso-tech	IDM101	TE:2421	12	25-Oct-2013
Hygrometer	R.S Components	1361C	TE: 3844	12	22-Mar-2014
DC Power Supply	Bang & Ouesen	SN17	ECI 3174	-	O/P Mon
Signal Generator	Marconi Instruments	2024	TT12108 / 112246/014	12	26-Oct-2013
Signal Generator	IFN	2025	TT12109 / 202303/587	12	26-Oct-2013
2 Navtex Test Modems (Same ID)	ICS	V4 Navtex Modem	TTA00244	-	TU
Power Splitter	Mini Circuits	ZSC-2-1	B UU05401239	-	TU
Power Splitter	Mini Circuits	ZSC-2-1	B UU05401239	-	TU
Spectrum Analyser	Rohde & Schwarz	FSEA	ECI 6943 / 833608	6	13-Sep-2013
10 MHz Frequency Reference	HP	58503B	ECI 6960	-	TU
<b>Section 2.20– Internal Storage, Tagging and Erasure of Messages</b>					
Power Supply	Iso-Tech	IPS 2010	TE: 2435	-	O/P Mon
Multimeter	Iso-Tech	IDM101	TE: 2419	12	09-Oct-2014
Signal Generator	Ifr	2023B	202304/933	-	O/P Mon
Modem	ICS	V4	103596	-	TU
USB to Serial	Brainboxes	US-842	24172	-	TU
<b>Section 2.21– Erasure of Message Identifications/Storage Time</b>					
Power Supply	Iso-Tech	IPS 2010	TE: 2435	-	O/P Mon
Multimeter	Iso-Tech	IDM101	TE: 2419	12	09-Oct-2014
Signal Generator	Ifr	2023B	202304/933	-	O/P Mon
Modem	ICS	V4	103596	-	TU
USB to Serial	Brainboxes	US-842	24172	-	TU
<b>Section 2.22 – Reception of Messages with Character Errors</b>					
Multimeter	Iso-tech	IDM101	TE:2421	12	25-Oct-2013
Hygrometer	R.S Components	1361C	TE: 3844	12	22-Mar-2014
DC Power Supply	Bang & Ouesen	SN17	ECI 3174	-	O/P Mon
Signal Generator	Marconi Instruments	2024	TT12108 / 112246/014	12	26-Oct-2013
Signal Generator	IFN	2025	TT12109 / 202303/587	12	26-Oct-2013
2 Navtex Test Modems (Same ID)	ICS	V4 Navtex Modem	TTA00244	-	TU
Power Splitter	Mini Circuits	ZSC-2-1	B UU05401239	-	TU
Power Splitter	Mini Circuits	ZSC-2-1	B UU05401239	-	TU
Spectrum Analyser	Rohde & Schwarz	FSEA	ECI 6943 / 833608	6	13-Sep-2013
10 MHz Frequency Reference	HP	58503B	ECI 6960	-	TU



Product Service

Instrument	Manufacturer	Type No.	Serial Number	Calibration Period (months)	Calibration Due
<b>Section 2.23 – Unsatisfactory Reception</b>					
Multimeter	Iso-tech	IDM101	TE:2421	12	25-Oct-2013
Hygrometer	R.S Components	1361C	TE: 3844	12	22-Mar-2014
DC Power Supply	Bang & Ouesen	SN17	ECI 3174	-	O/P Mon
Signal Generator	Marconi Instruments	2024	TT12108 / 112246/014	12	26-Oct-2013
Signal Generator	IFN	2025	TT12109 / 202303/587	12	26-Oct-2013
2 Navtex Test Modems (Same ID)	ICS	V4 Navtex Modem	TTA00244	-	TU
Power Splitter	Mini Circuits	ZSC-2-1	B UU05401239	-	TU
Power Splitter	Mini Circuits	ZSC-2-1	B UU05401239	-	TU
Spectrum Analyser	Rohde & Schwarz	FSEA	ECI 6943 / 833608	6	13-Sep-2013
10 MHz Frequency Reference	HP	58503B	ECI 6960	-	TU
<b>Section 2.24 – Power Off Check</b>					
Multimeter	Iso-tech	IDM101	TE:2421	12	25-Oct-2013
Hygrometer	R.S Components	1361C	TE: 3844	12	22-Mar-2014
DC Power Supply	Bang & Ouesen	SN17	ECI 3174	-	O/P Mon
<b>Section 2.25 – Brown-Out Test</b>					
Multimeter	Iso-tech	IDM101	TE:2421	12	25-Oct-2013
Hygrometer	R.S Components	1361C	TE: 3844	12	22-Mar-2014
DC Power Supply	Bang & Ouesen	SN17	ECI 3174	-	O/P Mon
<b>Section 2.26 – UTC Handling Check</b>					
Power Supply	Iso-Tech	IPS 2010	TE: 2435	-	O/P Mon
Multimeter	Iso-Tech	IDM101	TE: 2419	12	09-Oct-2014
Signal Generator	Ifr	2023B	202304/933	-	O/P Mon
Modem	ICS	V4	103596	-	TU
USB to Serial	Brainboxes	US-842	24172	-	TU
<b>Section 2.27 – Spurious Emissions</b>					
Multimeter	Iso-tech	IDM101	TE:2421	12	25-Oct-2013
Hygrometer	R.S Components	1361C	TE: 3844	12	22-Mar-2014
DC Power Supply	Bang & Ouesen	SN17	ECI 3174	-	O/P Mon
Spectrum Analyser	Rohde & Schwarz	FSEA	ECI 6943 / 833608	6	13-Sep-2013
10 MHz Frequency Reference	HP	58503B	ECI 6960	-	TU

TU – Traceability Unscheduled  
 O/P Mon – Output Monitored with Calibrated Equipment



### 3.2 MEASUREMENT UNCERTAINTY

For a 95% confidence level, the measurement uncertainties for defined systems are:-

Test Discipline	MU
INS Input Electrical	-
INS Input Performance	-
INS Output Electrical	-
INS Output Performance	-
Printer Output Electrical	-
Printer Output Performance	-
Exclusion of Stations	-
Exclusion of Message Categories	-
Receiver Test Facility	-
Search and Rescue Alarm Provision and Reset	-
Additional Alarms	-
Call Sensitivity	1.6 dB
Interference Rejection and Blocking Immunity	-
Co-channel Rejection	-
Intermodulation	-
Off-Frequency Transmitter	-
Simultaneous Operation on Several Receive Frequencies	-
Protection of Input Circuits	-
Tests of Technical Characteristics (ITU-R Recommendation M.540)	-
Internal Storage, Message Tagging and Erasure of Oldest Message Identification	-
Erasure of Message Identifications / Storage Time	-
Reception of Messages with Character Errors	-
Unsatisfactory Reception	-
Power-Off Check	-
Brown-Out Test	-
UTC Handling Check	-
Spurious Emissions	0.6 dB
Equipment Manuals – checks of the manufacturer's documentation	-
Marking and identification	-



Product Service

## **SECTION 4**

### **PHOTOGRAPHS**



4.1 PHOTOGRAPHS OF EQUIPMENT UNDER TEST (EUT)



Front View



Rear View

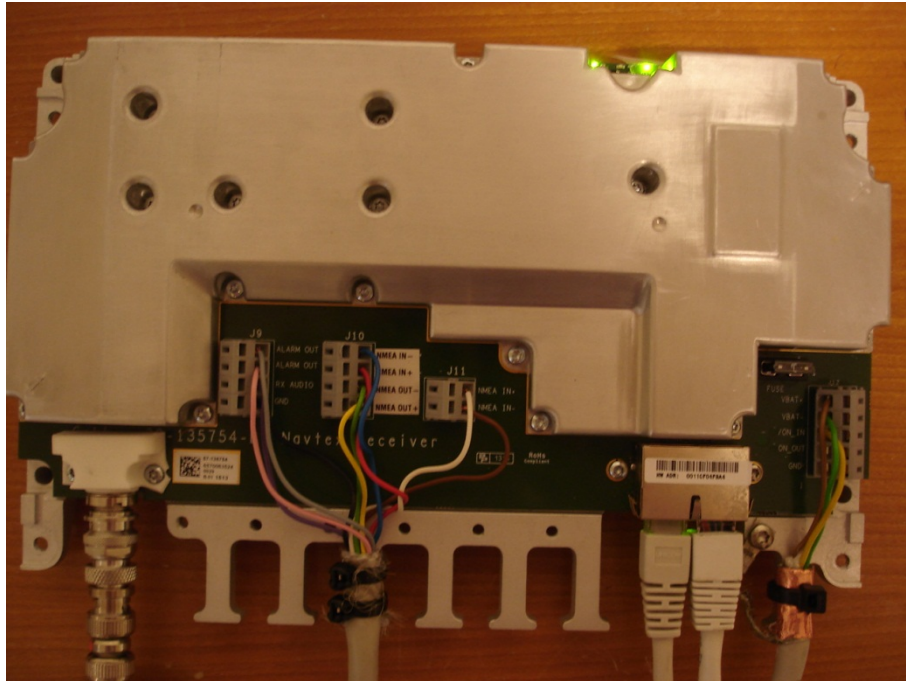

Internal View



Product Service

## **SECTION 5**

### **ACCREDITATION, DISCLAIMERS AND COPYRIGHT**



Product Service

## 5.1 ACCREDITATION, DISCLAIMERS AND COPYRIGHT



This report relates only to the actual item/items tested.

Our UKAS Accreditation does not cover opinions and interpretations and any expressed are outside the scope of our UKAS Accreditation.

Results of tests not covered by our UKAS Accreditation Schedule are marked NUA  
(Not UKAS Accredited).

This report must not be reproduced, except in its entirety, without the written permission of  
TÜV SÜD Product Service

© 2013 TÜV SÜD Product Service