

ARINC 600 CONNECTOR
NON ENVIRONMENTAL
AMPHENOL PART NO :
AJ2-203CF-40081577
CAVITY A : 71W1A
CAVITY B : 120Q2
CAVITY C : 12F5C2

CONNECTING PART
NON ENVIRONMENTAL
AMPHENOL PART NO :
AD2-203CF-30081510
CAVITY A : 71W1A
CAVITY B : 120Q2
CAVITY C : 12F5C2

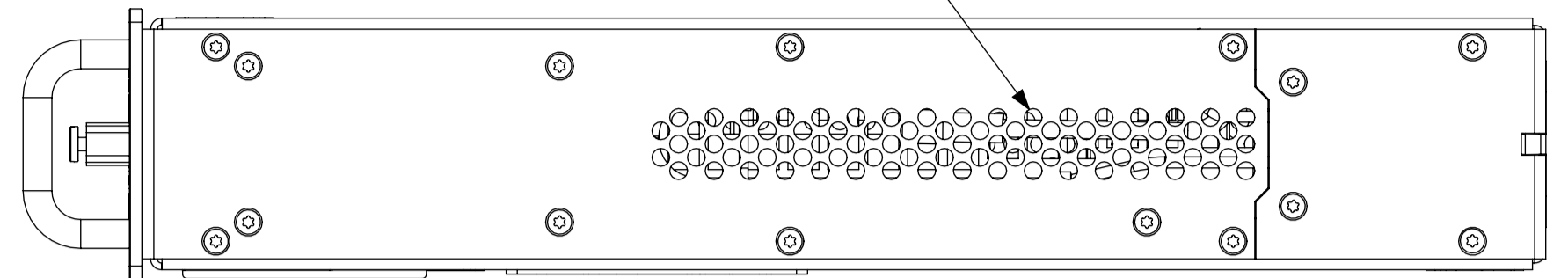

NOTE 5

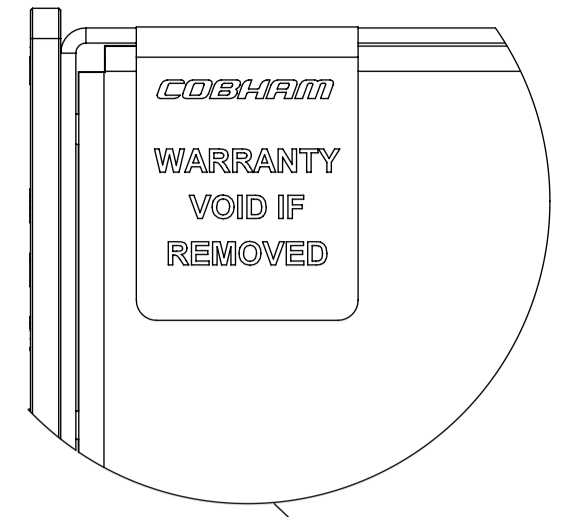
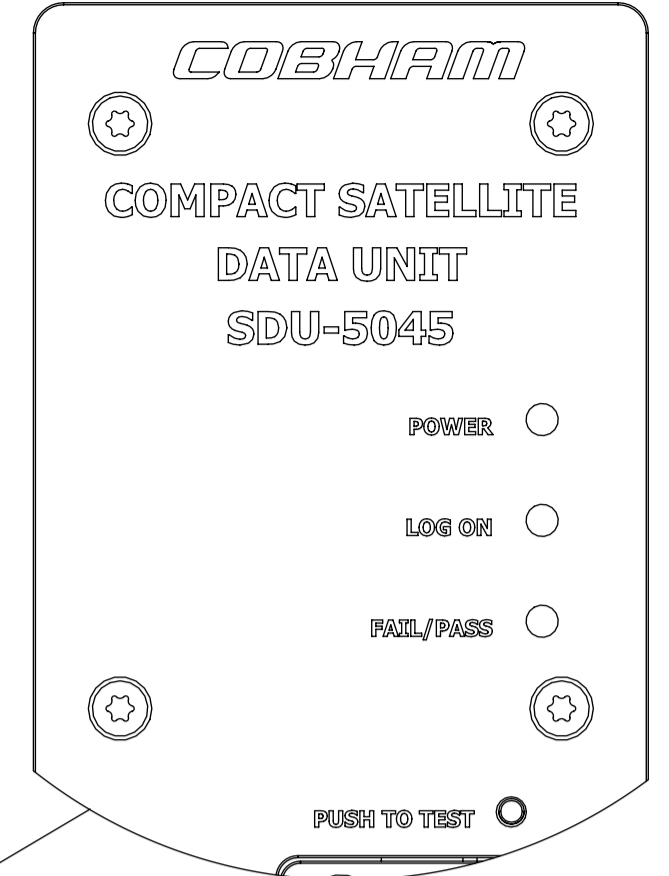

HISTORY				
VER	REV	DESCRIPTION	DATE	APPROVAL
A	-	ORIGINAL	2020.04.29	Jesper Sundberg
B	-	PART NUMBER UPDATED	2020.12.01	Mathias Perrier
C	-	CERTIFICATION LABEL ADDED	2021.03.11	Mathias Perrier

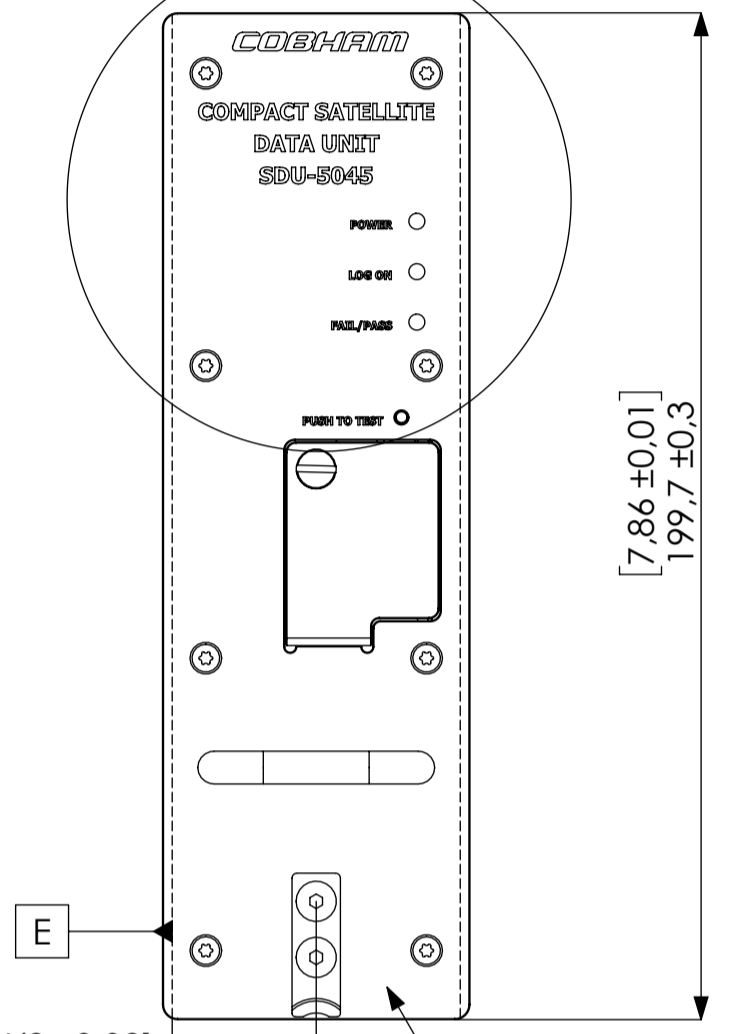
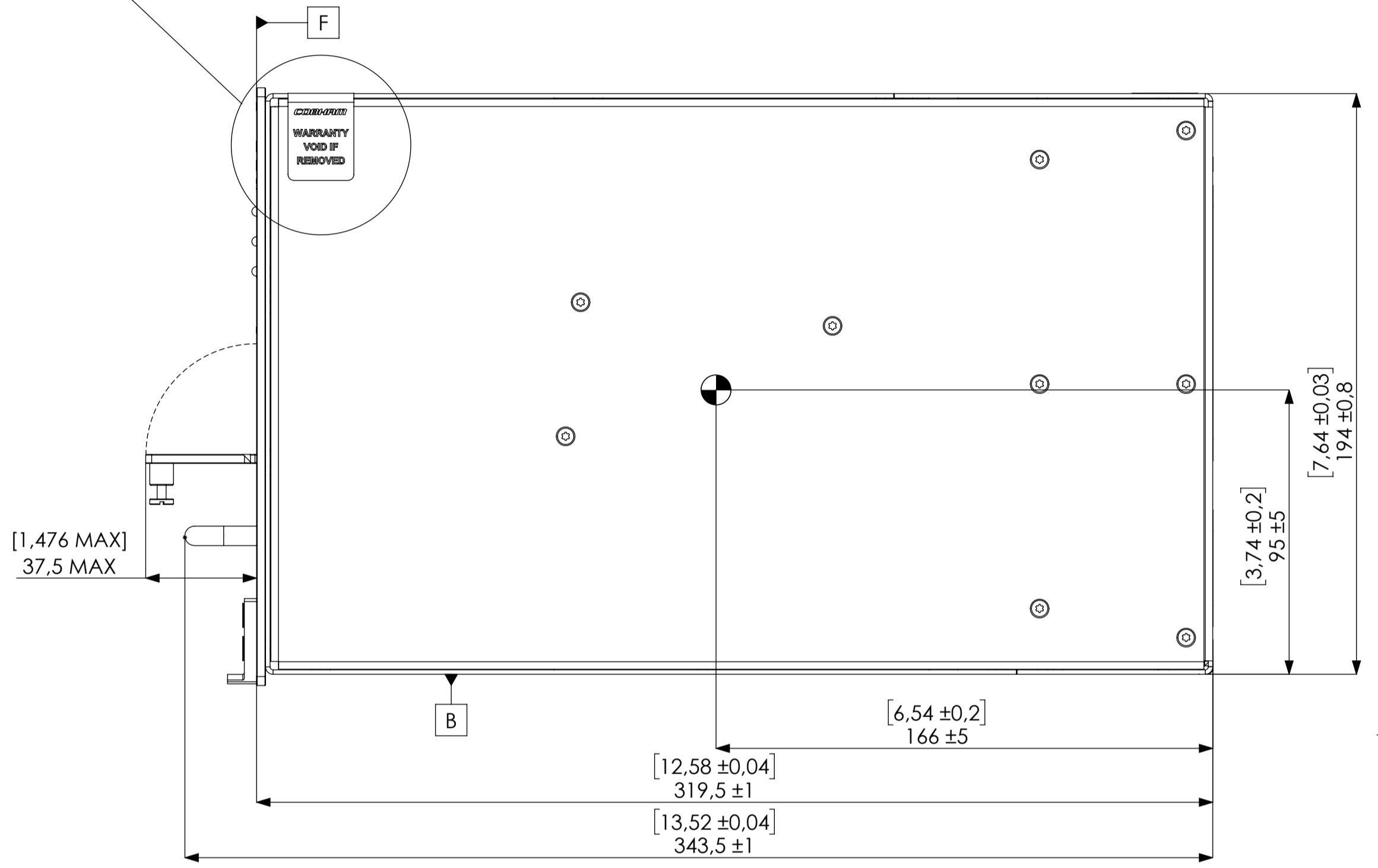
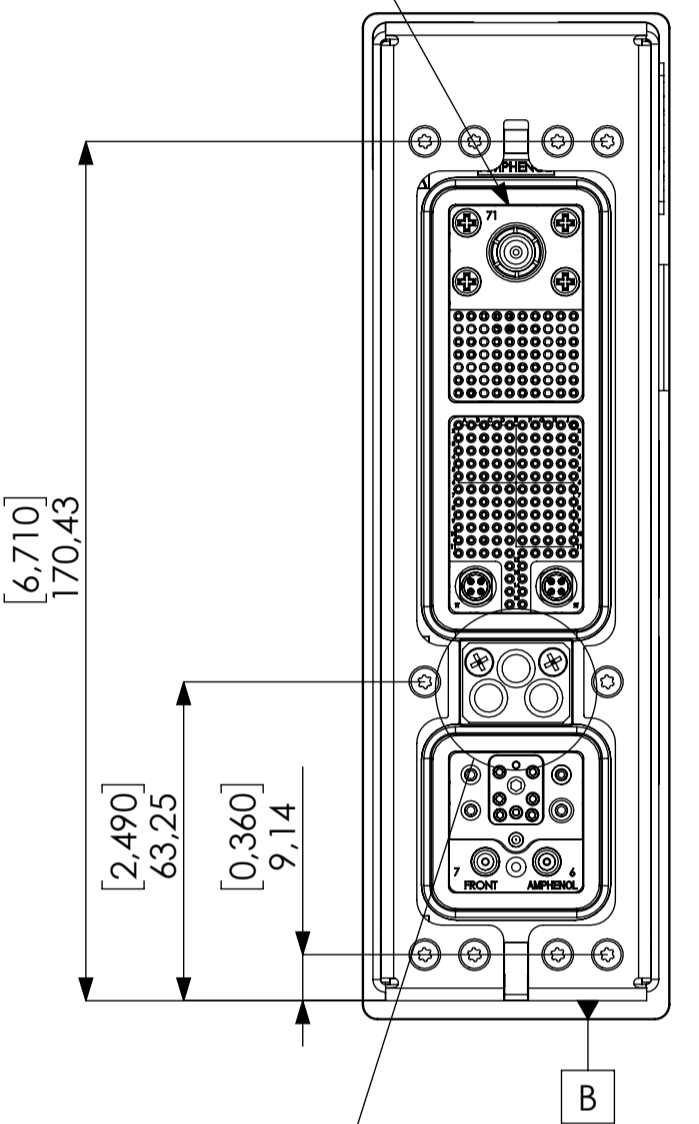

NOTE 10

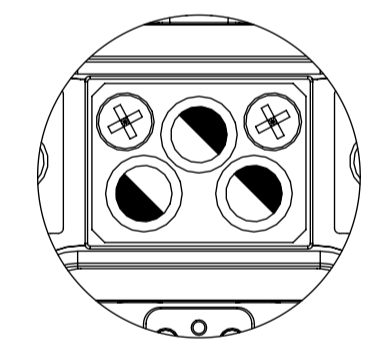
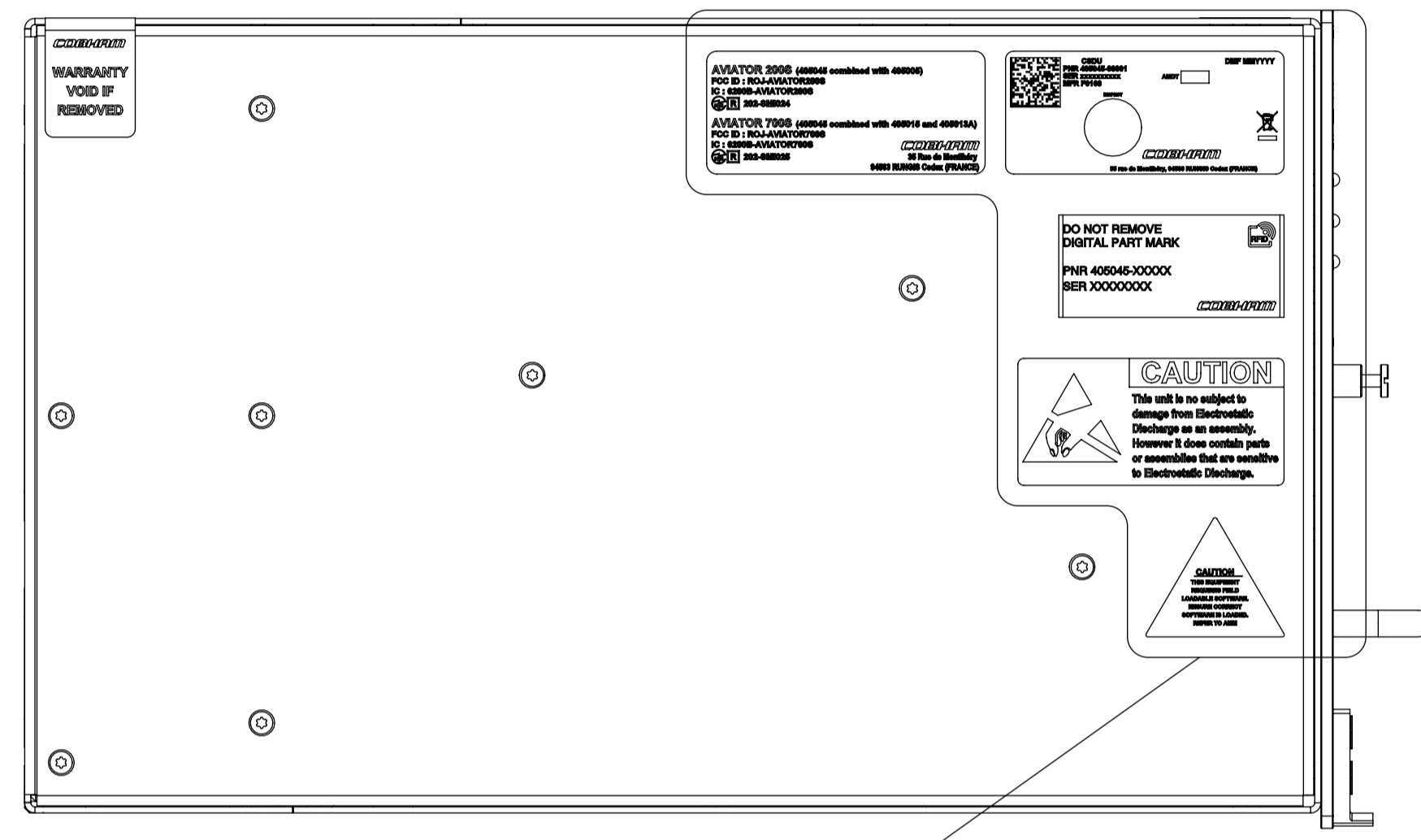

SEE NOTE 3
INDEX CODE 81

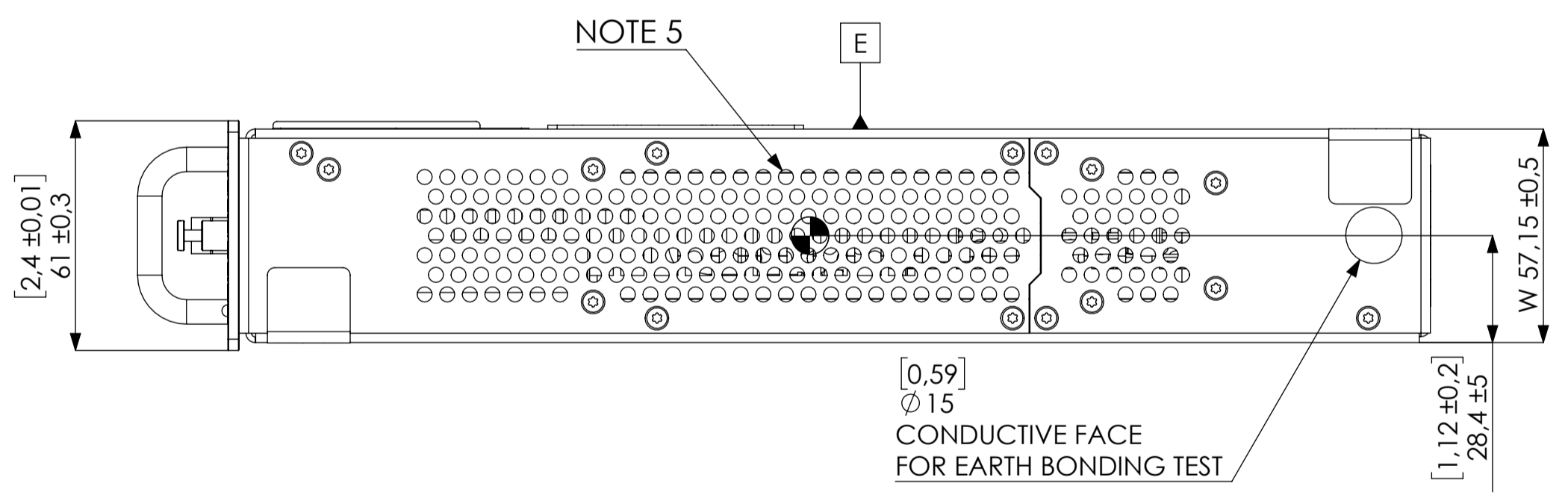

NOTE 5

CONDUCTIVE FACE FOR EARTH BONDING TEST

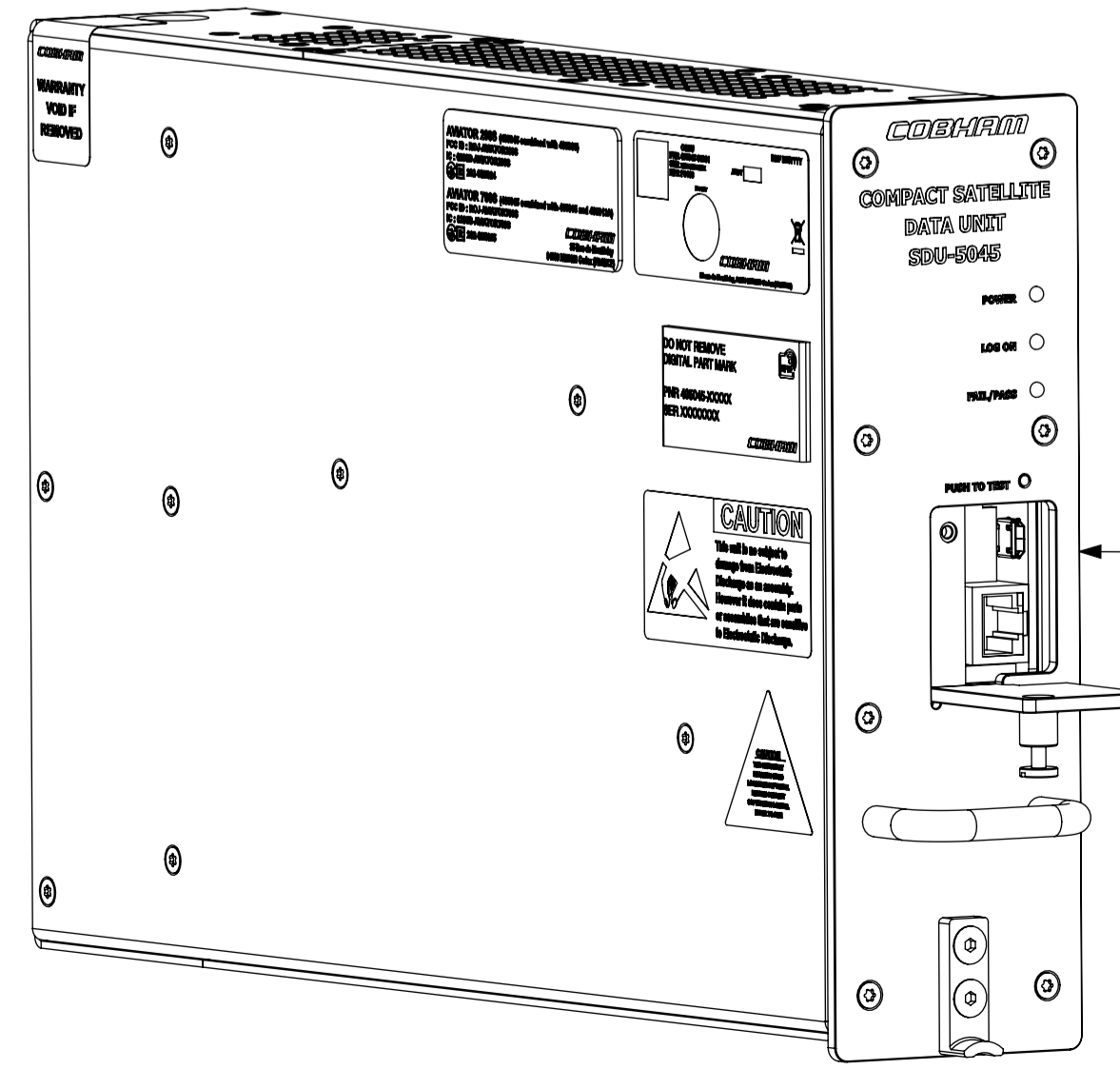
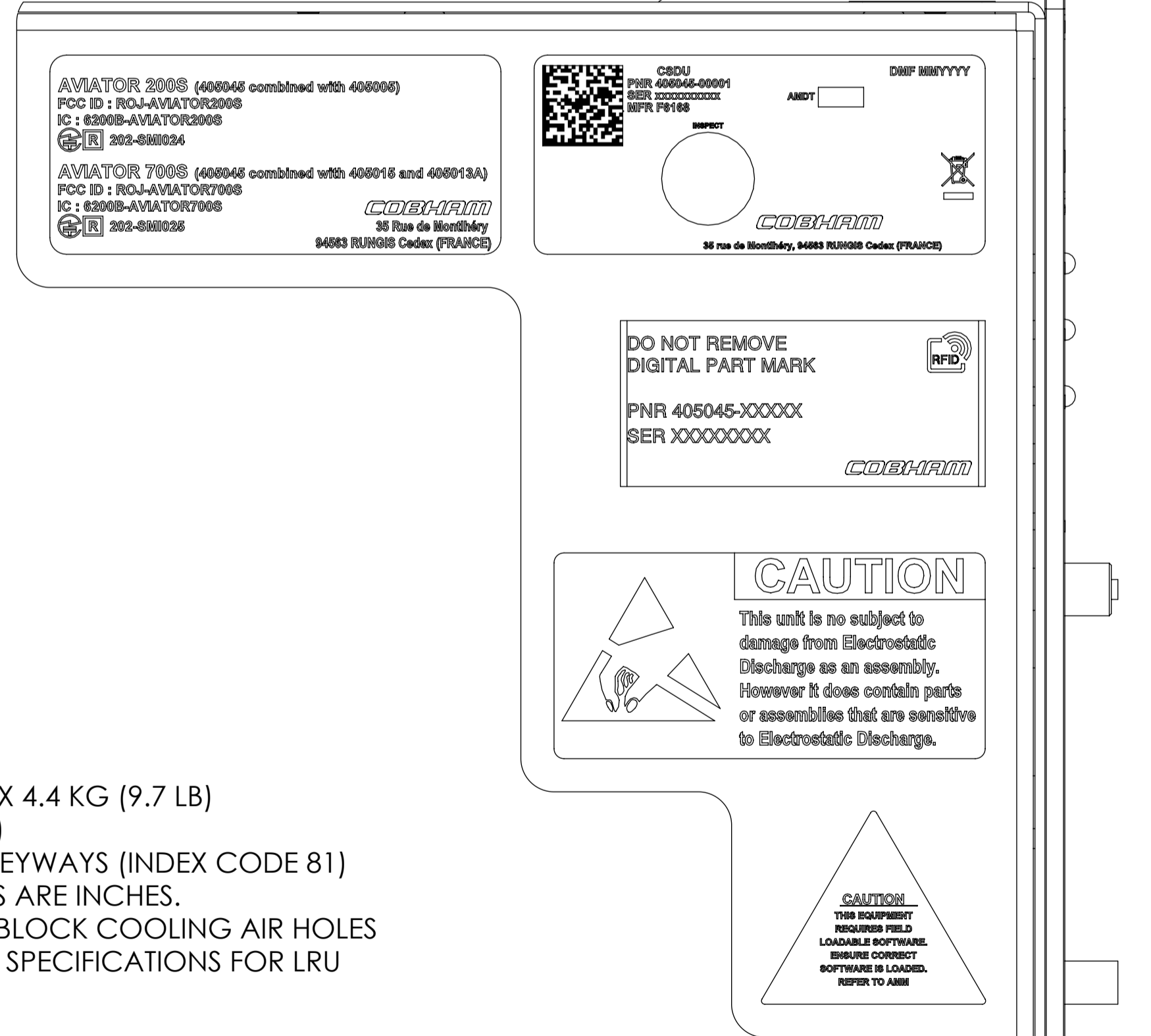

- MAINTENANCE CONNECTOR
10/100 BASE-T ETHERNET CONNECTOR
CONNECTING PART :
10/100 BASE-T ETHERNET CONNECTOR RJ45 MALE
- MICRO USB 2.0 TYPE B CONNECTOR
CONNECTING PART
MICRO USB 2.0 TYPE B PLUG
- MAINTENANCE CONNECTOR COVER

NOTES :

- UNIT WEIGHT 4.2 KG (9.26 LB). GUARANTEED WEIGHT MAX 4.4 KG (9.7 LB)
- INDICATES APPROXIMATE CENTER OF GRAVITY (COG)
- DARK PORTION INDICATES SOLID PART OF POLARISING KEYWAYS (INDEX CODE 81)
- DIMENSIONS ARE MILLIMETERS. DIMENSIONS IN BRACKETS ARE INCHES.
- 26 KG/HR FORCED AIR COOLING IS REQUIRED. DO NOT BLOCK COOLING AIR HOLES
- ALL EXTERNAL DIMENSIONS CONFORM TO ARINC 600-19 SPECIFICATIONS FOR LRU CASE SIZE 2

MATERIAL AND FINISH :

- MATERIAL : ALUMINIUM ALLOY
- FINISH : CHEMICAL CONVERSION TO MIL-DTL-5541F TYPE II CLASS 3
- PAINT : PPG AEROSPACE COATING
PRIMER : DESOPRIME ® CFCA7502E
TOPCOAT : DESOTHANE ® CA8311 HS POLYURETHANE BLACK MATT
- FRONT FACE BLACK ANODIZED ALUMINIUM

PART NUMBER 405045-00001

SURFACE TREATMENT: SEE NOTES		UNLESS OTHERWISE SPECIFIED DIMENSIONS ARE IN MILLIMETRE AND TOLERANCES IN ACCORDANCE WITH DS 2769			
MATERIAL: SEE NOTES		DR: M... 2020.12.01	CH: ... 2020.12.01	OUTLINE DRAWING SDU 5045	
		AP: ... 2020.12.01	PR: ... 2020.12.01	SIZE A1	ASSET NO. DRAWING NO. 94-173522
				SCALE 1:1,5	SHEET 1 OF 1

THIS DRAWING CONTAINS INFORMATION THAT IS PROPRIETARY TO COBHAM PLC. AND SHOULD NOT BE USED WITHOUT WRITTEN PERMISSION