



FCC TEST REPORT

Job No. : GPEM2306000344EC
Applicant : CanTops Co., Ltd.
Equipment Under Test (EUT) :
 Product Name : iMAN+
 Model Name : CTS-CFHD-AA
 Alt. Model Name : CTS-CFHD-AA-FL, CTS-CFHD-AA-CN
FCC Authorization Type : Certification
Applied Standards : FCC Part 15 Subpart B, Class A
FCC ID : RMN-CTS-CFHD
Date of Receipt : June 7, 2023
Date of Test : June 23, 2023 ~ June 26, 2023
Date of Issue : June 28, 2023
Test Results : Complied

Tested by	:	 ----- Luther Choi
Reviewed by	:	 ----- Julia Choi

This test report does not assure KOLAS accreditation.

- 1) The results of this test report are effective only to the items tested.
- 2) The SGS Korea is not responsible for the sampling, the results of this test report apply to the sample as received.

Remarks :

This document is issued by the Company subject to its General Conditions of Service printed overleaf, available on request or accessible at <http://www.sgs.com/en/Terms-and-Conditions.aspx> and, for electronic format documents, subject to Terms and Conditions for Electronic Documents at www.sgs.com/terms_e-document.htm.
 The results shown in this test report refer only to the sample(s) tested unless otherwise stated. This Test Report cannot be reproduced, except in full.

Contents

1. General Information.....	4
1.1 Client Information.....	4
1.2 Test Laboratory.....	4
1.3 General Information of E.U.T.	4
1.4 Operating Modes and Conditions.....	4
1.5 Peripheral Equipments.....	5
1.6 Cable List.....	5
1.7 System Configurations.....	6
1.8 Test System Layout	6
1.9 Modifications/Notes.....	7
1.10 Applicable Standards for Testing	7
1.11 Summary of Test Results.....	7
2. Emission Test.....	8
2.1 Test Results.....	8
2.2 Test Method and Limits.....	8
2.2.1 Test Method.....	8
2.2.2 Test Limits.....	8
2.3 Conducted Disturbance	9
2.3.1 Test Equipments.....	9
2.3.2 Test Site.....	9
2.3.3 Environment Conditions.....	9
2.3.4 Test Results.....	10
2.4 Radiated Emission	16
2.4.1 Test Equipments.....	16
2.4.2 Test Site.....	16
2.4.3 Environment Conditions.....	16
2.4.4 Test Results.....	17
Appendix A : Measurement Uncertainty	26

Revision History

Revision	Report number	Description
0	F690501-RF-EMC001490	Initial
1		

1. General Information

1.1 Client Information

Applicant	CanTops Co., Ltd.
Applicant Address	(A-1002~1008 Digital Empire BLDG), 16, Deogyong-daero 1556beon-gil, Yeongtong-gu, Suwon-si, Gyeonggi-do, Republic of Korea
Manufacturer	CanTops Co., Ltd.
Manufacturer Address	(A-1002~1008 Digital Empire BLDG), 16, Deogyong-daero 1556beon-gil, Yeongtong-gu, Suwon-si, Gyeonggi-do, Republic of Korea

1.2 Test Laboratory

Name and Address	SGS Korea Co., Ltd.
- Giheung Laboratory	35, Giheungdanji-ro 121beon-gil, Giheung-gu, Yongin-si, Gyeonggi-do, Republic of Korea
- Gunpo Laboratory	4, LS-ro 182beon-gil, Gunpo-si, Gyeonggi-do, 15807, Republic of Korea
- Dongtan Laboratory	12, Dongtansandan 10-gil, Hwaseong-si, Gyeonggi-do, 18487, Republic of Korea
FCC Registration No.	KR0150
IC Registration No.	7837B
Phone	+ 82 31 548 0710
Fax	+ 82 31 548 0719
e-mail	julia.choi@sgs.com

1.3 General Information of E.U.T.

Classification	Specification
Product Name	iMAN+
Model Name	CTS-CFHD-AA
Alt. Model Name	CTS-CFHD-AA-FL, CTS-CFHD-AA-CN
Model Differences	<ul style="list-style-type: none"> - CTS-CFHD-AA-FL : All are the same as the basic model, but the model name is different depending on the use of the sales business. - CTS-CFHD-AA-CN : The external appearance and circuit are all the same as the basic model but port is blocked because the CID Checker don't applied.
Serial No.	-
EMI Classification	Class A
Internal Clock Frequency	5 850 MHz
Rated Power	100 - 240 V~, 50/60 Hz(For Adapter), DC 7.2 V(For Battery)
Test Voltage	120 V~, 60 Hz
H/W Version	2.1
S/W Version	1.0
Port	RS422 CON, 12V Power CON, CID CHECKER, 24V Power CON RS232 CON(Unused/Administrator Port)
Components	Main Body, Switching Adaptor
Function	As a kind of TP, manual operation and monitoring of VHL can be done at once at site using IR, 2.4G RF or 5G RF radio communication.

1.4 Operating Modes and Conditions

Operating mode	Operating Condition
1) Charging + IR Communication	A state in which the EUT's internal battery is charged through the switching adapter and IR communication is performed with HPIO, a peripheral device.
2) Charging + RS-422 Communication	A state in which the EUT's internal battery is charged through the switching adapter and RS-422 communication with the notebook computer, a peripheral device.
3) Charging + Optical Communication	A state in which the internal battery of the EUT's charged through the switching adapter and the connected CIDO-Sensor communicates optically with the peripheral CIDR-Sensor.

1.5 Peripheral Equipments

Description	Model	Serial No.	Manufacturer	Note.
CID-R	CTS-CIDR-MC	-	CanTops Co., Ltd.	Korea
HPIO	CTS-HPIO-25	-	CanTops Co., Ltd.	Korea
CIDO-Sensor	CTS-CIDO-SE-1-0	-	CanTops Co., Ltd.	Korea
CIDR-Sensor	CTS-CIDR-SE-1-0	-	CanTops Co., Ltd.	Korea
CID-R	CTS-CIDR-MC	-	CanTops Co., Ltd.	Korea
CID-R AC/DC Adapter	GM42-240775-D	B1808035359	FOSHAN SHUNDE GUANYUDA POWER SUPPLY CO.,LTD	China
Notebook Computer	NT740U5L	0MMN91BH800200Y	Samsung Electronics Co., Ltd.	-

1.6 Cable List

Start		END		Cable Spec.		Used core
Name	I/O Port	Name	I/O Port	Length (m)	Shield	
1) Charging + IR Communication Mode						
EUT	RS422 CON	Notebook Computer	USB	1.5	Unshield	No
	12V Power CON	Switching Adaptor (EUT)	DC OUT	0.8	Unshield	No
	CID CHECKER	CIDO-Sensor	I/O	1.0	Unshield	No
	24V Power CON	HPIO	I/O	1.0	Unshield	No
	-	HPIO	-	-	-	-
Notebook Computer	DC IN	Notebook Computer AC/DC Adapter	DC OUT	1.3	Unshield	No
Notebook Computer AC/DC Adapter	AC IN	AC Power Source	-	1.5	Unshield	No
Switching Adaptor(EUT)	AC IN	AC Power Source	-	-	-	-
2) Charging + RS-422 Communication Mode						
EUT	RS422 CON	Notebook Computer	USB	1.5	Unshield	No
	12V Power CON	Switching Adaptor (EUT)	DC OUT	0.8	Unshield	No
	CID CHECKER	CIDO-Sensor	I/O	1.0	Unshield	No
	24V Power CON	HPIO	I/O	1.0	Unshield	No
	-	HPIO	-	-	-	-
Notebook Computer	DC IN	Notebook Computer AC/DC Adapter	DC OUT	1.3	Unshield	No
Notebook Computer AC/DC Adapter	AC IN	AC Power Source	-	1.5	Unshield	No
Switching Adaptor(EUT)	AC IN	AC Power Source	-	-	-	-
3) Charging + Optical Communication Mode						
EUT	RS422 CON	Notebook Computer	USB	1.5	Unshield	No
	12V Power CON	Switching Adaptor (EUT)	DC OUT	0.8	Unshield	No
	CID CHECKER	CIDO-Sensor	I/O	1.0	Unshield	No
	24V Power CON	HPIO	I/O	1.0	Unshield	No
	-	HPIO	-	-	-	-
Notebook Computer	DC IN	Notebook Computer AC/DC Adapter	DC OUT	1.3	Unshield	No

Notebook Computer AC/DC Adapter	AC IN	AC Power Source	-	1.5	Unshield	No
Switching Adaptor(EUT)	AC IN	AC Power Source	-	-	-	-
CIDO-Sensor	-	CIDR-Sensor	-	-	-	-
CIDR-Sensor	I/O	CID-R	Lane1-1	1.0	Unshield	No
CID-R	CT	CID-R AC/DC Adapter	DC OUT	0.8	Unshield	No
CID-R AC/DC Adapter	AC IN	AC Power Source	-	-	-	-

1.7 System Configurations

Description	Model	Serial No.	Manufacturer	Note
Switching Adaptor	FJ-SW1202000N	-	SHENZHEN FUJIA APPLIANCE CO.,LTD.	China
Battery	PWS2S1P-3.5A	-	Power CO.LTD.	Korea
LCD Board	-	-	-	-
Main Board	CTS-CFHD-AA01 VER2.1	-	CanTops Co., Ltd.	Korea

1.8 Test System Layout

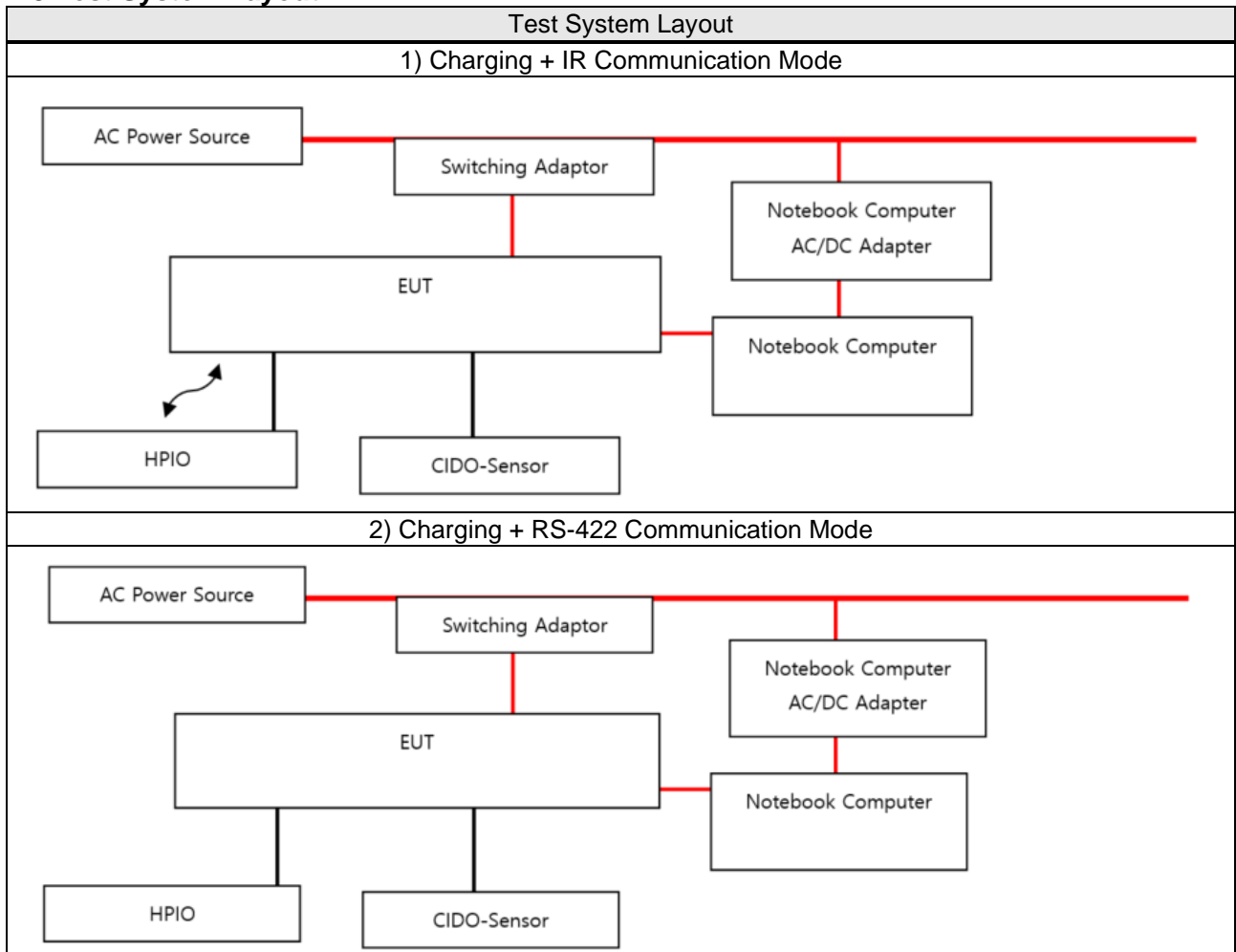

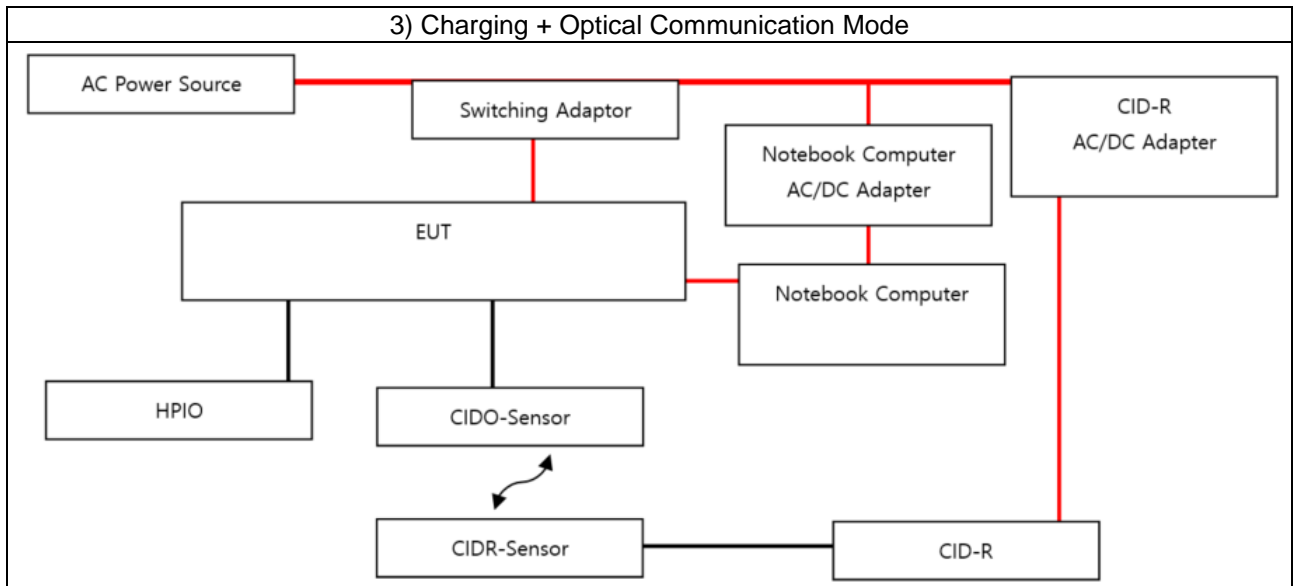

1.9 Modifications/Notes

- There was no modified item during the test.

1.10 Applicable Standards for Testing

Standards	Status	Deviation
FCC Part 15 : Subpart B	Applicable	No Deviation

1.11 Summary of Test Results

Test Item	Standards	Results
Conducted Emission	FCC Part 15 Subpart B Section 15.107 ANSI C63.4a:2017	Complied
Radiated Emission	FCC Part 15 Subpart B Section 15.109 ANSI C63.4a:2017	Complied

Note : Test methods of all test items are performed according to the basic standards in this table.

EMISSION

2.1 Test Results

Test Items	Standards	Test Results
Conducted Emission	FCC Part 15 Subpart B Section 15.107 ANSI C63.4a:2017	Complied
Radiated Emission	FCC Part 15 Subpart B Section 15.109 ANSI C63.4a:2017	Complied

2.2 Test Method and Limits

2.2.1 Test Method

Test Items	Measuring Frequency Range	RBW	Measuring Distance
Conducted Emission	0.15 MHz ~ 30 MHz	9 kHz	-
Radiated Emission	30 MHz ~ 1 GHz	120 kHz	10 m & 3 m
	Above 1 GHz	1 MHz	3 m

Note : 10 m method of radiated emission measurement is only applied to Class A equipment over the frequency range of 30 MHz ~ 1 GHz. Except this, 3 m method is applied to Class B equipment over the frequency range of 30 MHz ~ 1 GHz and Class A and Class B equipment above 1 GHz.

2.2.2 Test Limits

-Conducted Emission Limits

Frequency Range	Limits(dB μ V)		Class
	Quasi-peak	Average	
0.15 MHz ~ 0.5 MHz	79	66	Class A
0.5 MHz ~ 30 MHz	73	60	
0.15 MHz ~ 0.5 MHz	66 to 56	56 to 46	Class B
0.5 MHz ~ 5 MHz	56	46	
5 MHz ~ 30 MHz	60	50	

Note : The lower limit shall apply at the transition frequencies. The limit decreases linearly with the logarithm of the frequency in the range 0.15 MHz to 0.5 MHz.

-Radiated Emission Limits below 1 GHz

Frequency Range	Limits(dB μ V/m)	Class
	Quasi-peak	
30 MHz ~ 88 MHz	39.0	Class A (10 m method)
88 MHz ~ 216 MHz	43.5	
216 MHz ~ 960 MHz	46.4	
960 MHz ~ 1 GHz	49.5	
30 MHz ~ 88 MHz	40.0	Class B (3 m method)
88 MHz ~ 216 MHz	43.5	
216 MHz ~ 960 MHz	46.0	
960 MHz ~ 1 GHz	54.0	

-Radiated Emission Limits above 1 GHz (3 m method)

Frequency Range	Limits(dB μ V/m)		Class
	Average	Peak	
Above 1 GHz	59.5	79.5	Class A
Above 1 GHz	54.0	74.0	Class B

Note : The limits of class A equipment is extrapolated using an extrapolation factor of 20 dB/decade because it was measured at 3 m distance not 10 m distance.

2.3 Conducted Disturbance

The initial preliminary exploratory scans were performed over the measuring frequency range(0.15 MHz to 30 MHz) using a max hold mode incorporating a Peak detector and CISPR-Average detector and using the EMI measuring software. The final test data was measured using a Quasi-Peak detector and CISPR-Average detector.

Note. Measuring software

- Giheung Lab.: EMC32(V10.40.10) from R&S
- Gunpo Lab.: EMC32(V10.60.20) from R&S
- Dongtan Lab.: EMC32(V10.40.00) from R&S

2.3.1 Test Equipments

Equipment	Model	Manufacturer	Serial No	Cal Due. Date
EMI TEST RECEIVER	ESU8	R&S	100128	2024.05.25
2-LINE V-NETWORK	ENV216	R&S	101180	2023.08.04
ARTIFICIAL MAIN NETWORK	ESH2-Z5	R&S	100303	2023.08.24
PULSE LIMITER	ESH3-Z2	R&S	100283	2023.08.22

2.3.2 Test Site

Shield Room in Giheung Laboratory

2.3.3 Environment Conditions

Temperature	(Minimum 22.0, Maximum 22.9) °C
Humidity	(Minimum 43.0, Maximum 45.0) % R.H.
Atmospheric Pressure	(Minimum 100.0, Maximum 100.0) kPa
Test Date	June 26, 2023

2.3.4 Test Results

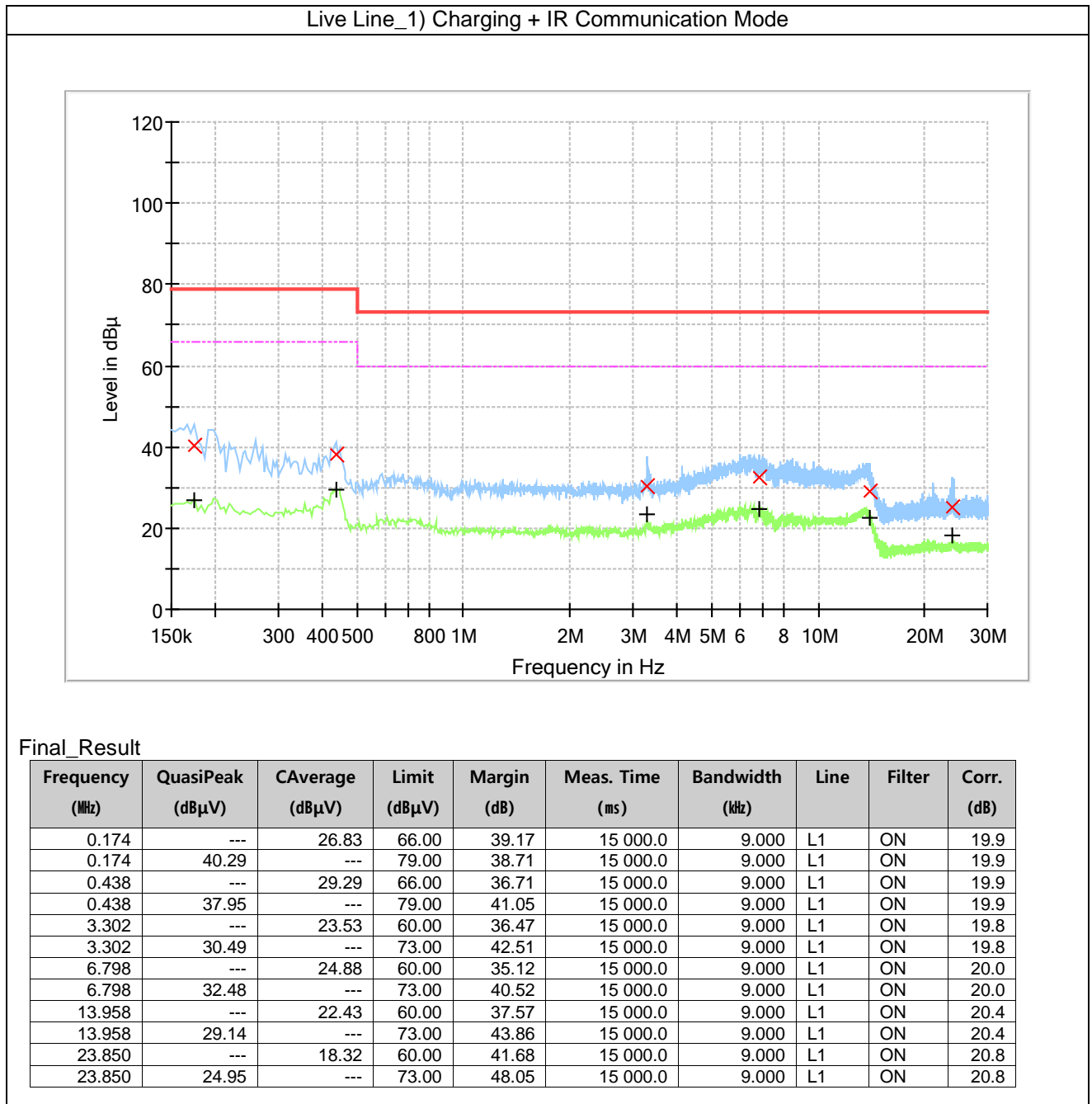

Neutral Line_1) Charging + IR Communication Mode

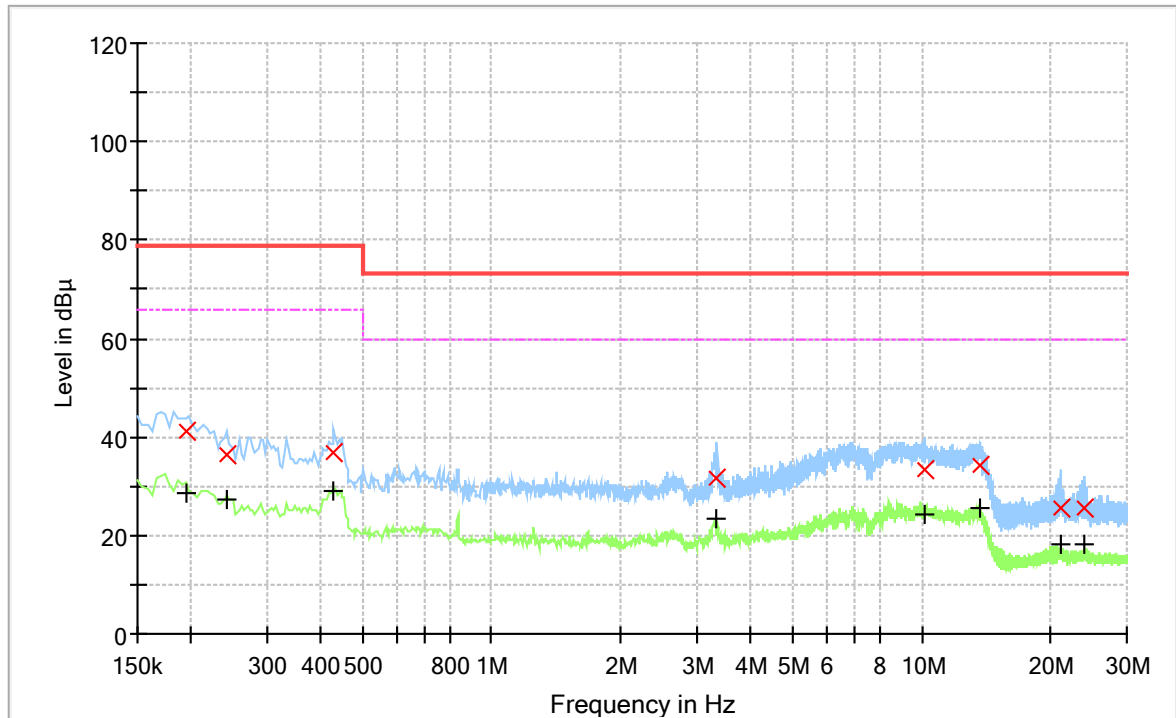

Final_Result

Frequency (MHz)	QuasiPeak (dBµV)	CAverage (dBµV)	Limit (dBµV)	Margin (dB)	Meas. Time (ms)	Bandwidth (kHz)	Line	Filter	Corr. (dB)
0.194	---	28.48	66.00	37.52	15 000.0	9.000	N	ON	19.8
0.194	40.96	---	79.00	38.04	15 000.0	9.000	N	ON	19.8
0.242	---	27.22	66.00	38.78	15 000.0	9.000	N	ON	19.6
0.242	36.53	---	79.00	42.47	15 000.0	9.000	N	ON	19.6
0.430	---	29.05	66.00	36.95	15 000.0	9.000	N	ON	19.9
0.430	36.71	---	79.00	42.29	15 000.0	9.000	N	ON	19.9
3.346	---	23.53	60.00	36.47	15 000.0	9.000	N	ON	19.8
3.346	31.64	---	73.00	41.36	15 000.0	9.000	N	ON	19.8
10.182	---	24.34	60.00	35.66	15 000.0	9.000	N	ON	20.1
10.182	33.24	---	73.00	39.76	15 000.0	9.000	N	ON	20.1
13.666	---	25.35	60.00	34.65	15 000.0	9.000	N	ON	20.4
13.666	34.04	---	73.00	38.96	15 000.0	9.000	N	ON	20.4
21.014	---	18.27	60.00	41.73	15 000.0	9.000	N	ON	20.7
21.014	25.50	---	73.00	47.50	15 000.0	9.000	N	ON	20.7
23.870	---	18.40	60.00	41.60	15 000.0	9.000	N	ON	20.8
23.870	25.35	---	73.00	47.65	15 000.0	9.000	N	ON	20.8

Live Line_2) Charging + RS-422 Communication Mode

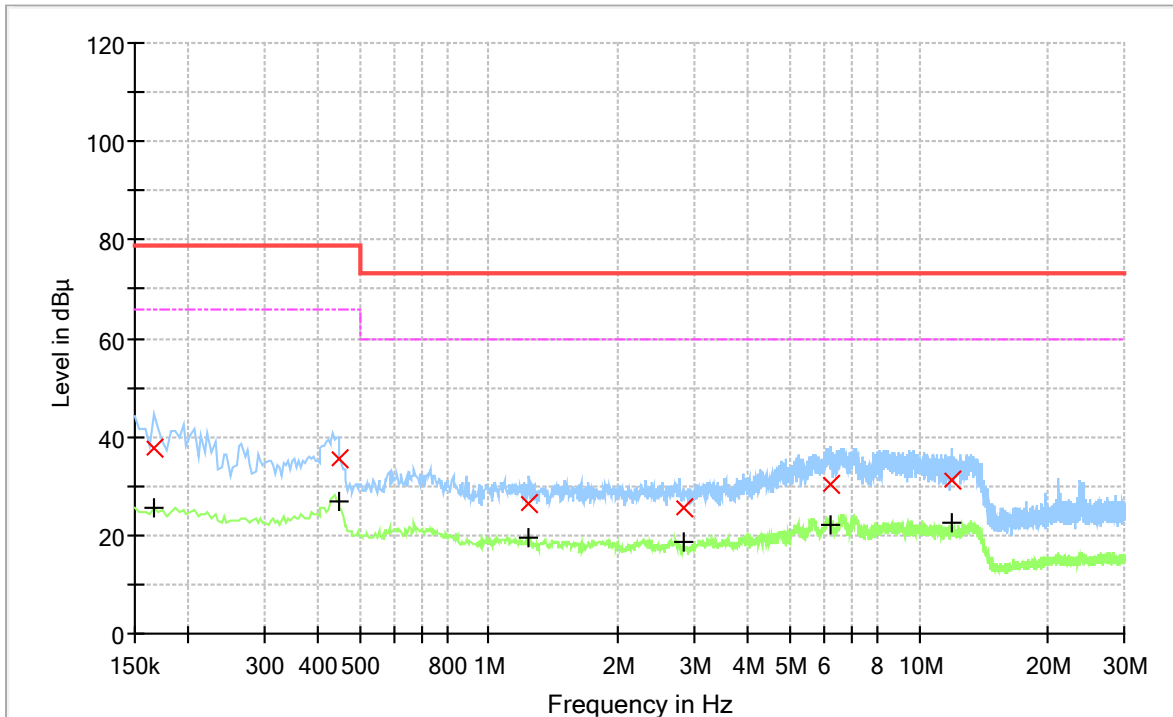

Final_Result

Frequency (MHz)	QuasiPeak (dBμV)	CAverage (dBμV)	Limit (dBμV)	Margin (dB)	Meas. Time (ms)	Bandwidth (kHz)	Line	Filter	Corr. (dB)
0.166	---	25.57	66.00	40.43	15 000.0	9.000	L1	ON	19.9
0.166	37.81	---	79.00	41.19	15 000.0	9.000	L1	ON	19.9
0.446	---	26.73	66.00	39.27	15 000.0	9.000	L1	ON	19.9
0.446	35.38	---	79.00	43.62	15 000.0	9.000	L1	ON	19.9
1.238	---	19.67	60.00	40.33	15 000.0	9.000	L1	ON	19.7
1.238	26.43	---	73.00	46.57	15 000.0	9.000	L1	ON	19.7
2.834	---	18.71	60.00	41.29	15 000.0	9.000	L1	ON	19.8
2.834	25.41	---	73.00	47.59	15 000.0	9.000	L1	ON	19.8
6.214	---	21.88	60.00	38.12	15 000.0	9.000	L1	ON	19.9
6.214	30.33	---	73.00	42.67	15 000.0	9.000	L1	ON	19.9
11.886	---	22.57	60.00	37.43	15 000.0	9.000	L1	ON	20.2
11.886	31.06	---	73.00	41.94	15 000.0	9.000	L1	ON	20.2

Neutral Line_2) Charging + RS-422 Communication Mode

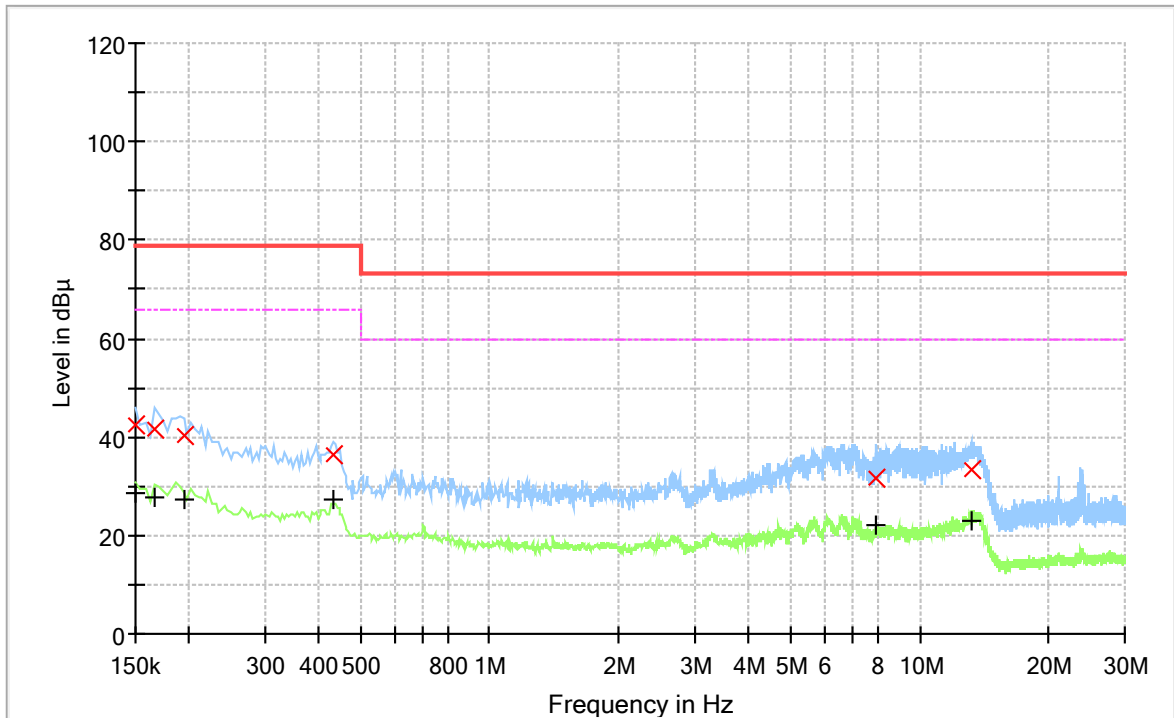

Final_Result

Frequency (MHz)	QuasiPeak (dBµV)	CAverage (dBµV)	Limit (dBµV)	Margin (dB)	Meas. Time (ms)	Bandwidth (kHz)	Line	Filter	Corr. (dB)
0.150	---	28.40	66.00	37.60	15 000.0	9.000	N	ON	19.7
0.150	42.39	---	79.00	36.61	15 000.0	9.000	N	ON	19.7
0.166	---	27.88	66.00	38.12	15 000.0	9.000	N	ON	19.9
0.166	41.67	---	79.00	37.33	15 000.0	9.000	N	ON	19.9
0.194	---	27.13	66.00	38.87	15 000.0	9.000	N	ON	19.8
0.194	40.12	---	79.00	38.88	15 000.0	9.000	N	ON	19.8
0.434	---	27.33	66.00	38.67	15 000.0	9.000	N	ON	19.9
0.434	36.55	---	79.00	42.45	15 000.0	9.000	N	ON	19.9
7.954	---	22.07	60.00	37.93	15 000.0	9.000	N	ON	20.0
7.954	31.46	---	73.00	41.54	15 000.0	9.000	N	ON	20.0
13.134	---	23.14	60.00	36.86	15 000.0	9.000	N	ON	20.4
13.134	33.24	---	73.00	39.76	15 000.0	9.000	N	ON	20.4

Live Line_3) Charging + Optical Communication Mode

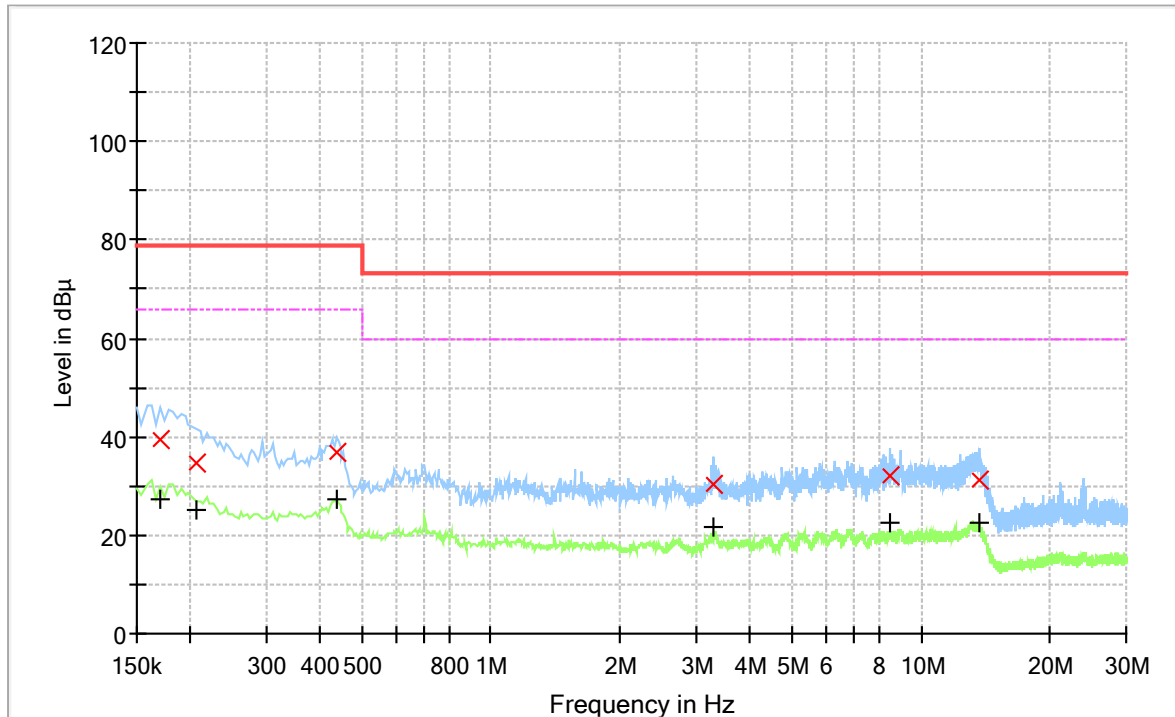

Final_Result

Frequency (MHz)	QuasiPeak (dBµV)	CAverage (dBµV)	Limit (dBµV)	Margin (dB)	Meas. Time (ms)	Bandwidth (kHz)	Line	Filter	Corr. (dB)
0.170	---	27.22	66.00	38.78	15 000.0	9.000	L1	ON	20.0
0.170	39.57	---	79.00	39.43	15 000.0	9.000	L1	ON	20.0
0.206	---	24.92	66.00	41.08	15 000.0	9.000	L1	ON	19.8
0.206	34.64	---	79.00	44.36	15 000.0	9.000	L1	ON	19.8
0.438	---	27.30	66.00	38.70	15 000.0	9.000	L1	ON	19.9
0.438	36.71	---	79.00	42.29	15 000.0	9.000	L1	ON	19.9
3.290	---	21.84	60.00	38.16	15 000.0	9.000	L1	ON	19.8
3.290	30.15	---	73.00	42.85	15 000.0	9.000	L1	ON	19.8
8.466	---	22.71	60.00	37.29	15 000.0	9.000	L1	ON	20.0
8.466	32.22	---	73.00	40.78	15 000.0	9.000	L1	ON	20.0
13.610	---	22.48	60.00	37.52	15 000.0	9.000	L1	ON	20.3
13.610	31.38	---	73.00	41.62	15 000.0	9.000	L1	ON	20.3

Neutral Line_3) Charging + Optical Communication Mode

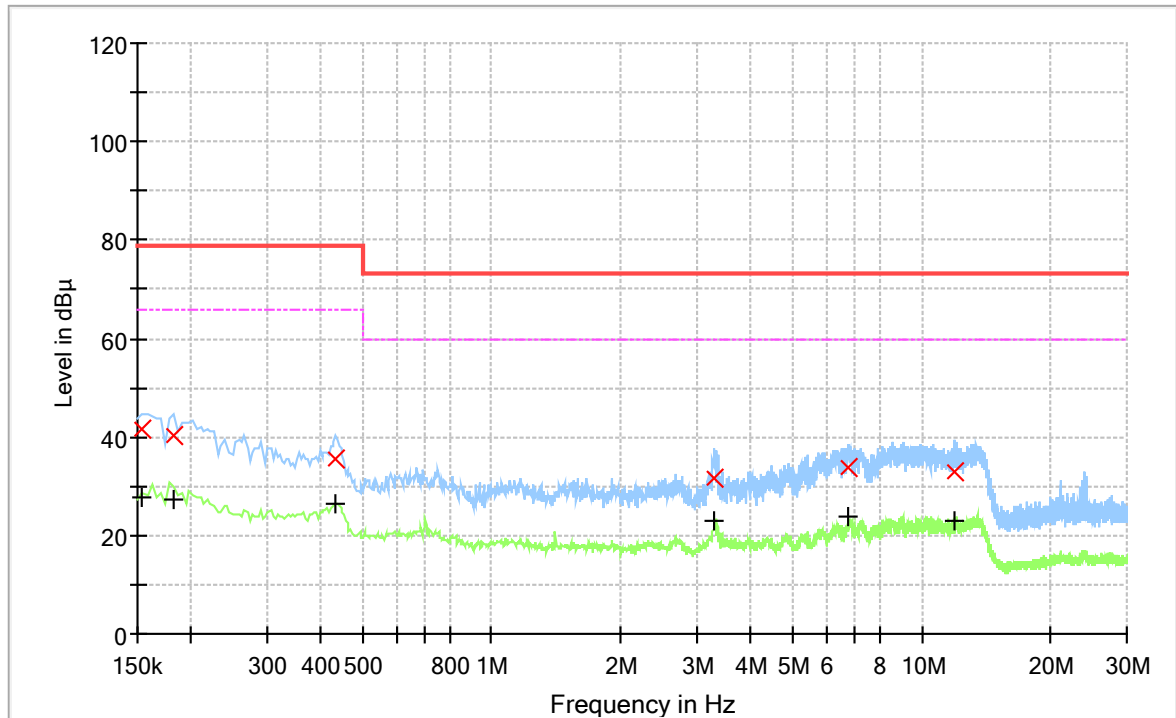

Final_Result

Frequency (MHz)	QuasiPeak (dBµV)	CAverage (dBµV)	Limit (dBµV)	Margin (dB)	Meas. Time (ms)	Bandwidth (kHz)	Line	Filter	Corr. (dB)
0.154	---	27.63	66.00	38.37	15 000.0	9.000	N	ON	19.7
0.154	41.80	---	79.00	37.20	15 000.0	9.000	N	ON	19.7
0.182	---	27.39	66.00	38.61	15 000.0	9.000	N	ON	19.9
0.182	40.32	---	79.00	38.68	15 000.0	9.000	N	ON	19.9
0.434	---	26.54	66.00	39.46	15 000.0	9.000	N	ON	19.9
0.434	35.32	---	79.00	43.68	15 000.0	9.000	N	ON	19.9
3.290	---	23.13	60.00	36.87	15 000.0	9.000	N	ON	19.8
3.290	31.59	---	73.00	41.41	15 000.0	9.000	N	ON	19.8
6.718	---	23.79	60.00	36.21	15 000.0	9.000	N	ON	20.0
6.718	34.00	---	73.00	39.00	15 000.0	9.000	N	ON	20.0
11.918	---	22.90	60.00	37.10	15 000.0	9.000	N	ON	20.3
11.918	32.72	---	73.00	40.28	15 000.0	9.000	N	ON	20.3

Measurement Uncertainty : See Appendix A

Note : • (L1) : Live

• Margin = Limit – Quasi Peak or CAverage

• (N) : Neutral

• Corr. = LISN Factor + Cable loss + Pulse Limiter factor

Ex) In case

Freq ; 0.5 MHz, level ; 30 dB(µV), CL ; 0.2 dB, LISN ; 9.5 dB, P/L: 9.8 dB

Result = Level + CL + LISN + P/L

$$= 30 + 0.2 + 9.5 + 9.8$$

$$= 49.5$$

Margin = Limit – Result

$$= 79 - 49.5$$

$$= 29.5$$

2.4 Radiated Emission

The initial preliminary exploratory scans were performed over the measuring frequency range (30 MHz to 30 GHz) using a max hold mode incorporating a Peak detector by using the EMI measuring software. The final test data was measured using a Quasi-Peak detector below 1 GHz, Peak and CISPR Average detector above 1 GHz. Measurements were made with the antenna positioned in both the horizontal and vertical planes of polarization. The antenna height was varied from 1 m to 4 m and the EUT was rotated 360° to find the maximum emitting point for each frequency.

Note. Measuring software

- Giheung Lab.: EMC32(V10.40.10) from R&S
- Gunpo Lab.: EP5RE(V5.3.70) from TOYO
- Dongtan Lab.: EMC32(V10.40.10) from R&S

2.4.1 Test Equipments

Equipment	Model	Manufacturer	Serial No	Cal Due. Date
EMI TEST RECEIVER	ESU40	R&S	100075	2024.01.19
Hybrid ANTENNA	VULB 9163	SCHWARZBECK	9163-396	2024.03.22
Double Ridged Horn Antenna	HF907	R&S	100208	2024.03.09
Double Ridged Horn Antenna	BBHA9170	SCHWARZBECK	BBHA9170454	2023.07.07
PREAMPLIFIER	AM-1431	MITEQ	1336160	2024.05.23
AMPLIFIER	SCU 18	R&S	10070	2023.08.25
Low Noise Amplifier	TK-PA1840H	TESTEK	110006	2024.02.03

Note: The calibration period of every equipment is 1 year.

2.4.2 Test Site

10 m SEMI-ANECHOIC CHAMBER in Giheung Laboratory

2.4.3 Environment Conditions

Below 1 GHz

Temperature	(Minimum 21.0, Maximum 21.8) °C
Humidity	(Minimum 42.0, Maximum 44.0) % R.H.
Atmospheric Pressure	(Minimum 100.0, Maximum 100.0) kPa
Test Date	June 26, 2023

Above 1 GHz

Temperature	(Minimum 21.5, Maximum 22.7) °C
Humidity	(Minimum 47.0, Maximum 49.0) % R.H.
Atmospheric Pressure	(Minimum 100.2, Maximum 100.2) kPa
Test Date	June 23, 2023

2.4.4 Test Results

Below 1 GHz (3 m method)

1) Charging + IR Communication Mode

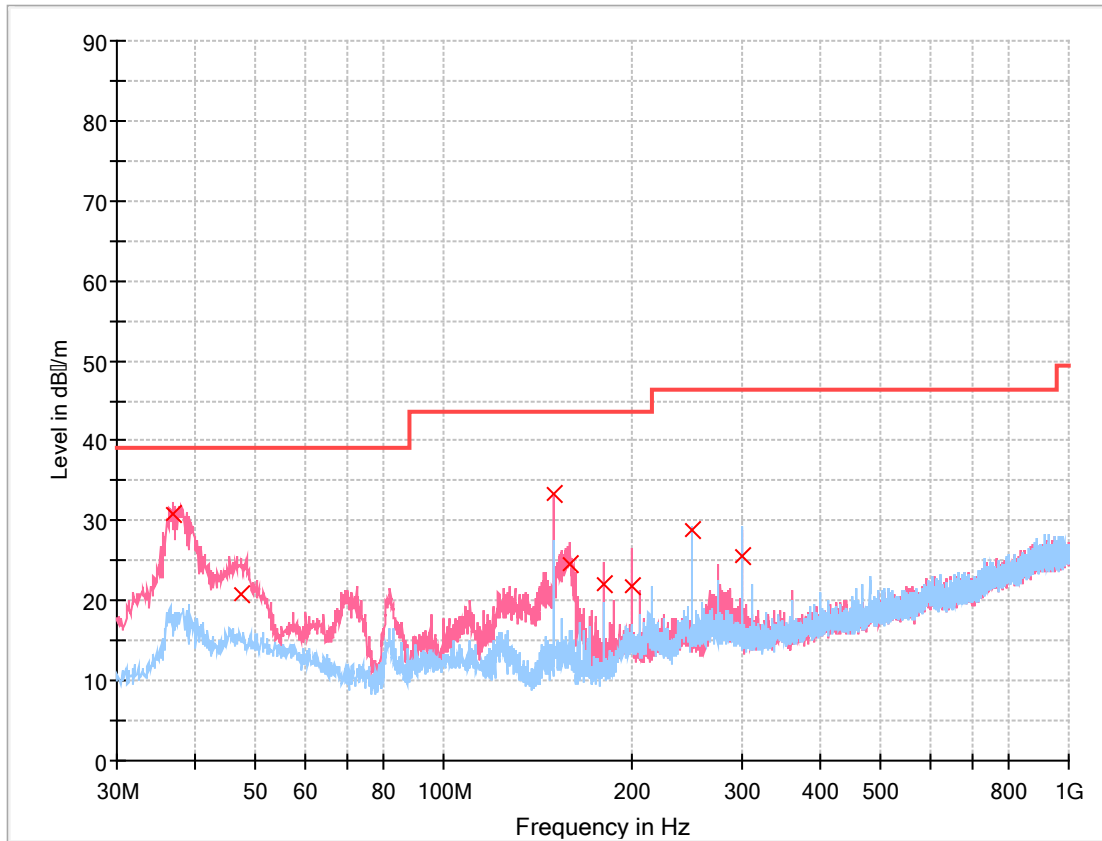

Final_Result

Frequency (MHz)	QuasiPeak (dBμV/m)	Limit (dBμV/m)	Margin (dB)	Meas. Time (ms)	Bandwidth (kHz)	Height (cm)	Pol	Azimuth (deg)	Corr. (dB)
36.887	30.91	39.10	8.19	15 000.0	120.000	200.0	V	94.0	-19.7
47.363	20.85	39.10	18.25	15 000.0	120.000	100.0	V	100.0	-17.5
149.989	33.26	43.52	10.26	15 000.0	120.000	100.0	V	83.0	-23.2
159.204	24.55	43.52	18.97	15 000.0	120.000	100.0	V	91.0	-22.7
179.962	22.07	43.52	21.45	15 000.0	120.000	100.0	V	336.0	-21.6
199.944	21.80	43.52	21.72	15 000.0	120.000	100.0	V	125.0	-19.8
249.996	28.75	46.50	17.75	15 000.0	120.000	400.0	H	354.0	-18.1
299.951	25.56	46.50	20.94	15 000.0	120.000	400.0	H	149.0	-17.3

2) Charging + RS-422 Communication Mode

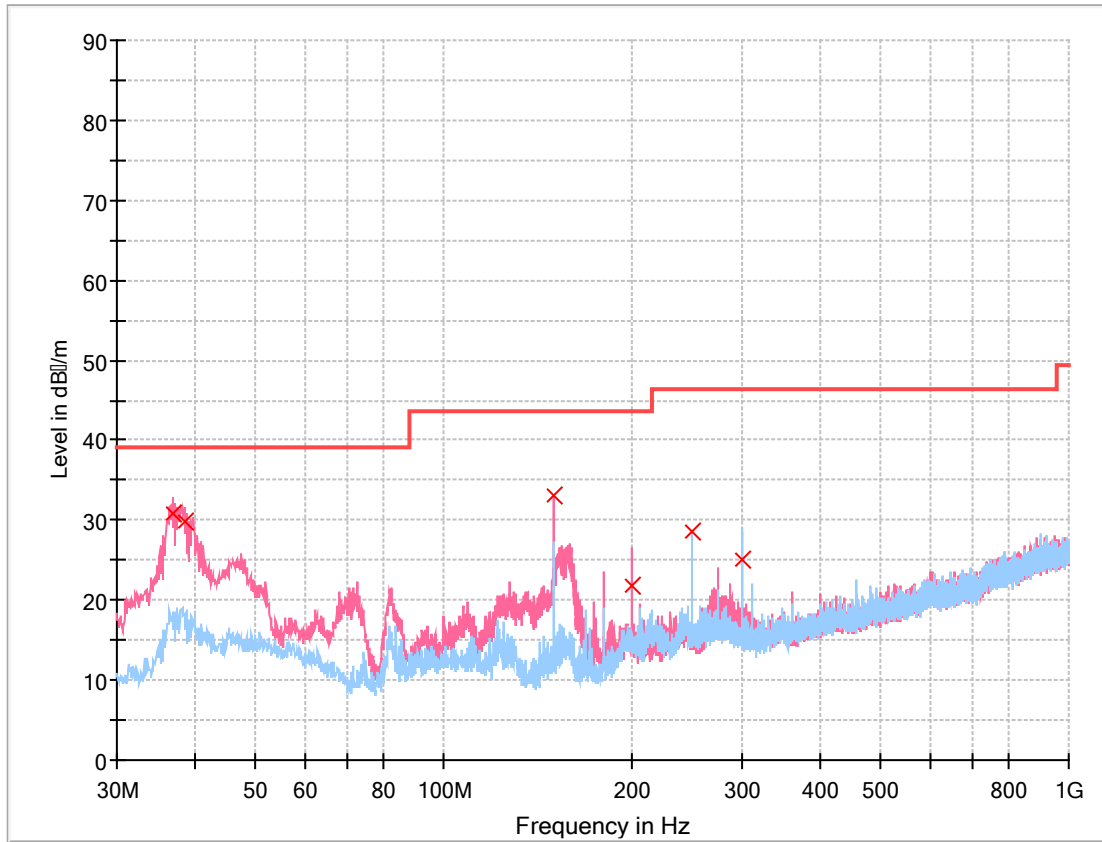

Final_Result

Frequency (MHz)	QuasiPeak (dBµV/m)	Limit (dBµV/m)	Margin (dB)	Meas. Time (ms)	Bandwidth (kHz)	Height (cm)	Pol	Azimuth (deg)	Corr. (dB)
36.887	30.89	39.10	8.21	15 000.0	120.000	200.0	V	77.0	-19.7
38.536	29.81	39.10	9.29	15 000.0	120.000	200.0	V	93.0	-19.1
149.989	32.99	43.52	10.53	15 000.0	120.000	100.0	V	101.0	-23.2
199.944	21.76	43.52	21.76	15 000.0	120.000	100.0	V	134.0	-19.8
249.996	28.63	46.50	17.87	15 000.0	120.000	400.0	H	0.0	-18.1
299.951	25.05	46.50	21.45	15 000.0	120.000	400.0	H	158.0	-17.3

3) Charging + Optical Communication Mode

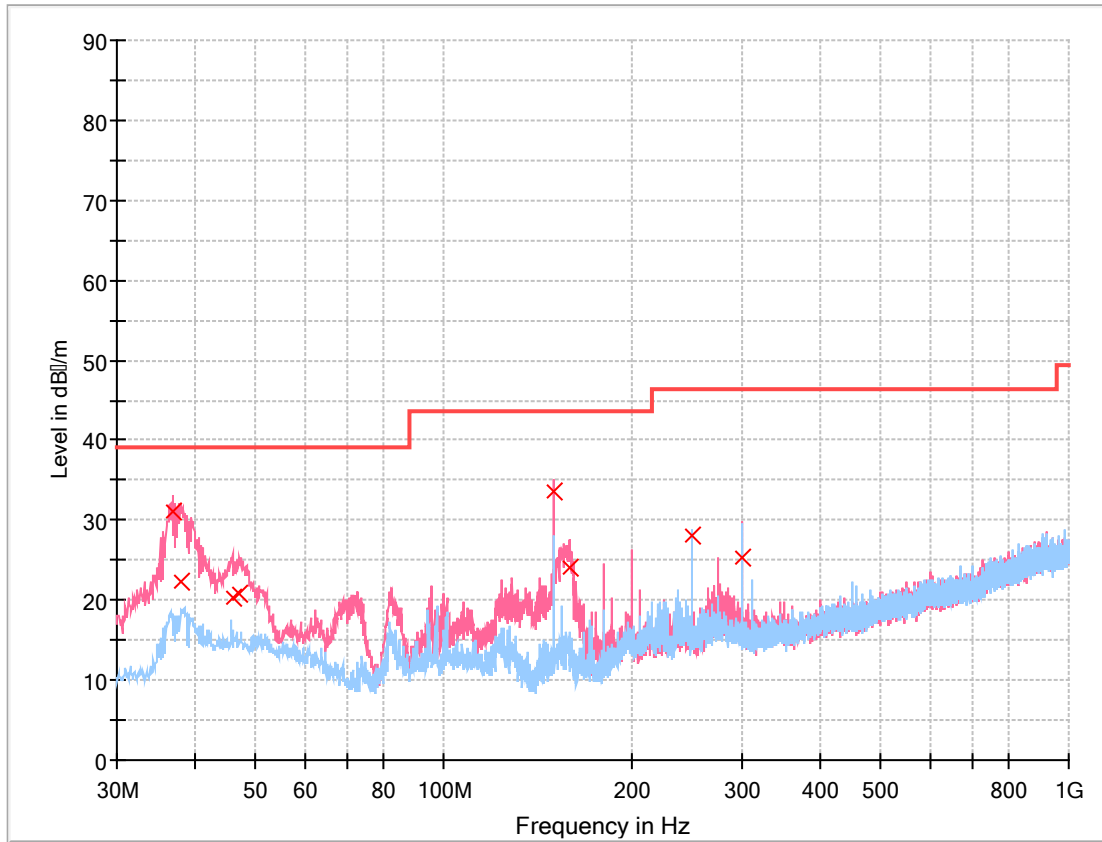

Final_Result

Frequency (MHz)	QuasiPeak (dBµV/m)	Limit (dBµV/m)	Margin (dB)	Meas. Time (ms)	Bandwidth (kHz)	Height (cm)	Pol	Azimuth (deg)	Corr. (dB)
36.887	31.07	39.10	8.03	15 000.0	120.000	200.0	V	93.0	-19.7
37.857	22.29	39.10	16.81	15 000.0	120.000	200.0	V	85.0	-19.3
45.908	20.30	39.10	18.80	15 000.0	120.000	100.0	V	0.0	-17.6
47.169	20.76	39.10	18.34	15 000.0	120.000	100.0	V	182.0	-17.5
149.989	33.71	43.52	9.81	15 000.0	120.000	100.0	V	82.0	-23.2
158.913	24.15	43.52	19.37	15 000.0	120.000	100.0	V	108.0	-22.7
249.996	27.98	46.50	18.52	15 000.0	120.000	400.0	H	19.0	-18.1
299.951	25.35	46.50	21.15	15 000.0	120.000	100.0	V	166.0	-17.3

Measurement Uncertainty: See Appendix A

Note : • POL H = Horizontal

• Margin = Limit – Quasi Peak

• POL V = Vertical

• Corr. = Antenna Factor + Cable loss – Amplifier Gain

Above 1 GHz (3 m method)

① 1 GHz ~ 18 GHz

1) Charging + IR Communication Mode

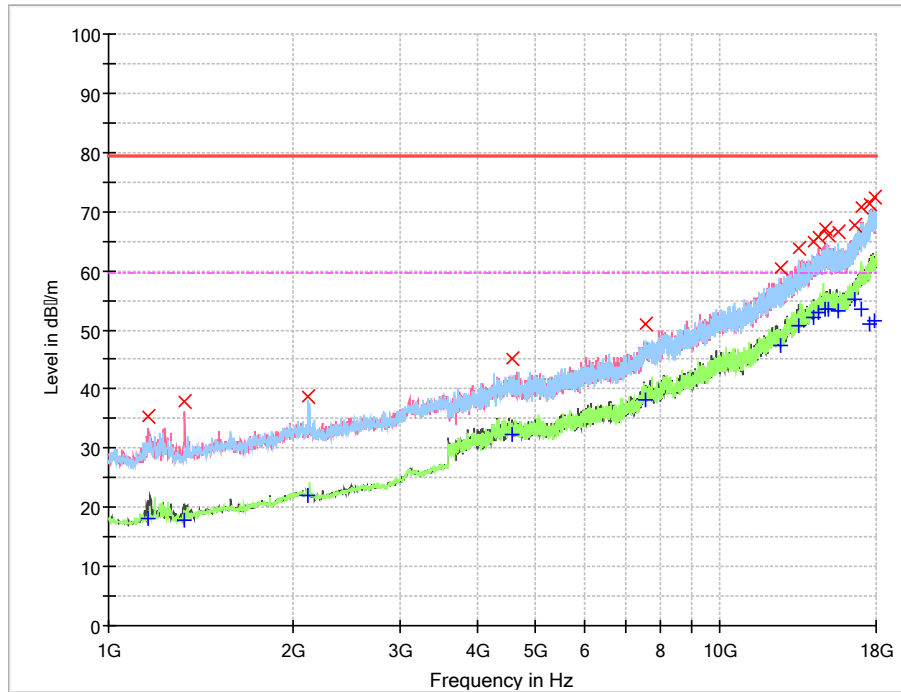

Final Result

Frequency (MHz)	MaxPeak (dBμV/m)	CAverage (dBμV/m)	Limit (dBμV/m)	Margin (dB)	Meas. Time(ms)	Bandwidth (kHz)	Height (cm)	Pol	Azimuth (deg)	Corr. (dB)
4 573.400	---	32.24	59.50	27.26	15 000.0	1 000.000	100.0	V	145.0	3.1
4 573.400	44.99	---	79.50	34.51	15 000.0	1 000.000	100.0	V	145.0	3.1
7 572.200	51.00	---	79.50	28.50	15 000.0	1 000.000	100.0	H	244.0	9.5
7 572.200	---	38.23	59.50	21.27	15 000.0	1 000.000	100.0	H	244.0	9.5
12 536.200	60.47	---	79.50	19.03	15 000.0	1 000.000	100.0	V	131.0	19.5
12 536.200	---	47.47	59.50	12.03	15 000.0	1 000.000	100.0	V	131.0	19.5
13 430.400	63.92	---	79.50	15.58	15 000.0	1 000.000	100.0	H	0.0	21.6
13 430.400	---	50.74	59.50	8.76	15 000.0	1 000.000	100.0	H	0.0	21.6
14 186.900	---	52.09	59.50	7.41	15 000.0	1 000.000	100.0	V	0.0	23.5
14 186.900	64.83	---	79.50	14.67	15 000.0	1 000.000	100.0	V	0.0	23.5
14 511.600	65.77	---	79.50	13.73	15 000.0	1 000.000	100.0	V	116.0	24.2
14 511.600	---	52.89	59.50	6.61	15 000.0	1 000.000	100.0	V	116.0	24.2
14 805.700	67.05	---	79.50	12.45	15 000.0	1 000.000	100.0	V	345.0	24.7
14 805.700	---	53.44	59.50	6.06	15 000.0	1 000.000	100.0	V	345.0	24.7
15 072.600	66.09	---	79.50	13.41	15 000.0	1 000.000	100.0	V	330.0	25.0
15 072.600	---	53.43	59.50	6.07	15 000.0	1 000.000	100.0	V	330.0	25.0
15 647.200	66.44	---	79.50	13.06	15 000.0	1 000.000	100.0	H	59.0	24.4
15 647.200	---	53.09	59.50	6.41	15 000.0	1 000.000	100.0	H	59.0	24.4
16 560.100	---	55.08	59.50	4.42	15 000.0	1 000.000	100.0	H	301.0	26.5
16 560.100	67.69	---	79.50	11.81	15 000.0	1 000.000	100.0	H	301.0	26.5
16 995.300	70.77	---	79.50	8.73	15 000.0	1 000.000	100.0	V	0.0	28.2
16 995.300	---	53.44	59.50	6.06	15 000.0	1 000.000	100.0	V	0.0	28.2
17 534.200	---	50.91	59.50	8.59	15 000.0	1 000.000	100.0	H	258.0	29.6
17 534.200	71.33	---	79.50	8.17	15 000.0	1 000.000	100.0	H	258.0	29.6
17 847.000	---	51.62	59.50	7.88	15 000.0	1 000.000	100.0	H	0.0	30.8
17 847.000	72.44	---	79.50	7.06	15 000.0	1 000.000	100.0	H	0.0	30.8

2) Charging + RS-422 Communication Mode

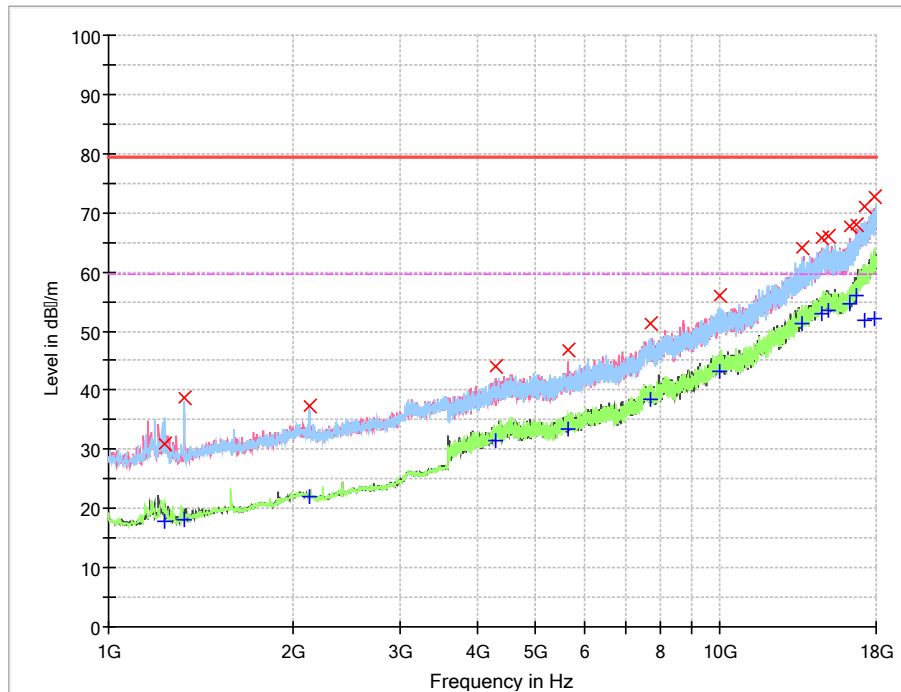

Final_Result

Frequency (MHz)	MaxPeak (dBμV/m)	CAverage (dBμV/m)	Limit (dBμV/m)	Margin (dB)	Meas. Time(ms)	Bandwidth (kHz)	Height (cm)	Pol	Azimuth (deg)	Corr. (dB)
1 238.000	30.79	---	79.50	48.71	15 000.0	1 000.000	100.0	H	8.0	-14.5
1 238.000	---	17.80	59.50	41.70	15 000.0	1 000.000	100.0	H	8.0	-14.5
1 328.100	38.69	---	79.50	40.81	15 000.0	1 000.000	100.0	H	0.0	-13.9
1 328.100	---	17.99	59.50	41.51	15 000.0	1 000.000	100.0	H	0.0	-13.9
2 125.400	---	21.93	59.50	37.57	15 000.0	1 000.000	100.0	H	288.0	-7.9
2 125.400	37.37	---	79.50	42.13	15 000.0	1 000.000	100.0	H	288.0	-7.9
4 284.400	---	31.43	59.50	28.07	15 000.0	1 000.000	100.0	V	341.0	2.7
4 284.400	43.93	---	79.50	35.57	15 000.0	1 000.000	100.0	V	341.0	2.7
5 654.600	---	33.50	59.50	26.00	15 000.0	1 000.000	100.0	V	204.0	4.9
5 654.600	46.66	---	79.50	32.84	15 000.0	1 000.000	100.0	V	204.0	4.9
7 677.600	---	38.44	59.50	21.06	15 000.0	1 000.000	100.0	H	0.0	9.9
7 677.600	51.19	---	79.50	28.31	15 000.0	1 000.000	100.0	H	0.0	9.9
9 970.900	56.05	---	79.50	23.45	15 000.0	1 000.000	100.0	H	59.0	14.9
9 970.900	---	43.12	59.50	16.38	15 000.0	1 000.000	100.0	H	59.0	14.9
13 649.700	63.95	---	79.50	15.55	15 000.0	1 000.000	100.0	H	106.0	22.1
13 649.700	---	51.15	59.50	8.35	15 000.0	1 000.000	100.0	H	106.0	22.1
14 639.100	65.75	---	79.50	13.75	15 000.0	1 000.000	100.0	V	218.0	24.4
14 639.100	---	52.97	59.50	6.53	15 000.0	1 000.000	100.0	V	218.0	24.4
15 059.000	65.89	---	79.50	13.61	15 000.0	1 000.000	100.0	H	0.0	25.0
15 059.000	---	53.41	59.50	6.09	15 000.0	1 000.000	100.0	H	0.0	25.0
16 279.600	67.56	---	79.50	11.94	15 000.0	1 000.000	100.0	V	29.0	25.4
16 279.600	---	54.53	59.50	4.97	15 000.0	1 000.000	100.0	V	29.0	25.4
16 658.700	---	55.88	59.50	3.62	15 000.0	1 000.000	100.0	V	0.0	27.0
16 658.700	68.09	---	79.50	11.41	15 000.0	1 000.000	100.0	V	0.0	27.0
17 182.300	---	51.81	59.50	7.69	15 000.0	1 000.000	100.0	H	0.0	28.6
17 182.300	70.92	---	79.50	8.58	15 000.0	1 000.000	100.0	H	0.0	28.6
17 901.400	72.66	---	79.50	6.84	15 000.0	1 000.000	100.0	V	191.0	31.1
17 901.400	---	52.04	59.50	7.10	15 000.0	1 000.000	100.0	V	191.0	31.1

3) Charging + Optical Communication Mode

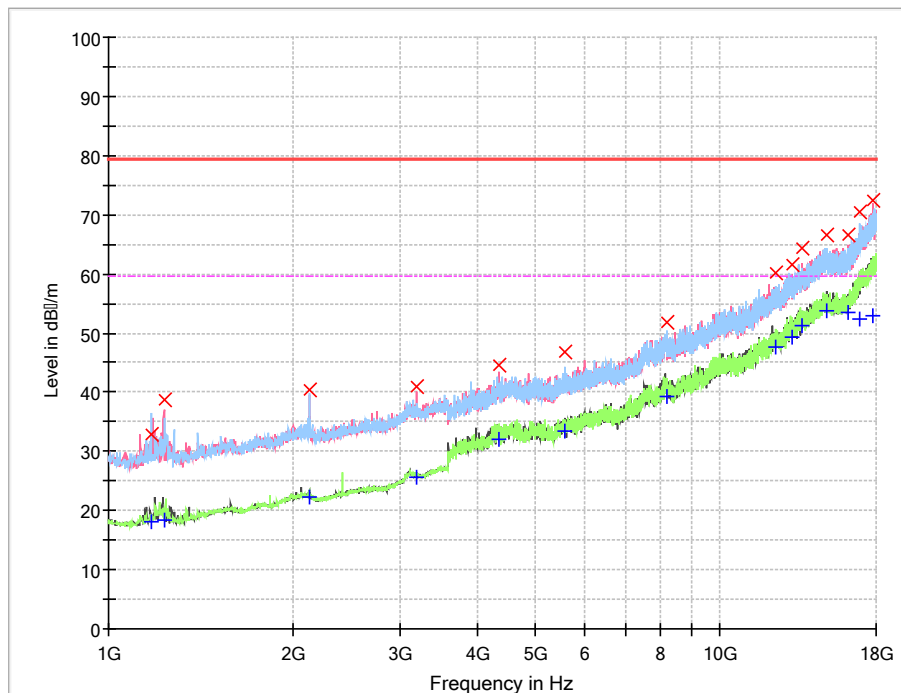

Final_Result

Frequency (MHz)	MaxPeak (dBμV/m)	CAverage (dBμV/m)	Limit (dBμV/m)	Margin (dB)	Meas. Time(ms)	Bandwidth (kHz)	Height (cm)	Pol	Azimuth (deg)	Corr. (dB)
1 173.400	32.83	---	79.50	46.67	15 000.0	1 000.000	100.0	H	200.0	-14.8
1 173.400	---	18.05	59.50	41.45	15 000.0	1 000.000	100.0	H	200.0	-14.8
1 231.200	---	18.51	59.50	40.99	15 000.0	1 000.000	100.0	V	325.0	-14.6
1 231.200	38.81	---	79.50	40.69	15 000.0	1 000.000	100.0	V	325.0	-14.6
2 128.800	---	22.15	59.50	37.35	15 000.0	1 000.000	100.0	V	298.0	-7.9
2 128.800	40.53	---	79.50	38.97	15 000.0	1 000.000	100.0	V	298.0	-7.9
3 196.400	41.08	---	79.50	38.42	15 000.0	1 000.000	100.0	V	351.0	-2.4
3 196.400	---	25.59	59.50	33.91	15 000.0	1 000.000	100.0	V	351.0	-2.4
4 340.500	---	32.16	59.50	27.34	15 000.0	1 000.000	100.0	V	325.0	3.0
4 340.500	44.61	---	79.50	34.89	15 000.0	1 000.000	100.0	V	325.0	3.0
5 578.100	---	33.38	59.50	26.12	15 000.0	1 000.000	100.0	H	0.0	4.9
5 578.100	46.69	---	79.50	32.81	15 000.0	1 000.000	100.0	H	0.0	4.9
8 179.100	---	39.20	59.50	20.30	15 000.0	1 000.000	100.0	H	50.0	10.8
8 179.100	51.81	---	79.50	27.69	15 000.0	1 000.000	100.0	H	50.0	10.8
12 332.200	60.16	---	79.50	19.34	15 000.0	1 000.000	100.0	H	0.0	19.2
12 332.200	---	47.65	59.50	11.85	15 000.0	1 000.000	100.0	H	0.0	19.2
13 088.700	---	49.17	59.50	10.33	15 000.0	1 000.000	100.0	V	339.0	20.8
13 088.700	61.70	---	79.50	17.80	15 000.0	1 000.000	100.0	V	339.0	20.8
13 632.700	---	51.18	59.50	8.32	15 000.0	1 000.000	100.0	V	76.0	22.1
13 632.700	64.26	---	79.50	15.24	15 000.0	1 000.000	100.0	V	76.0	22.1
14 970.600	66.50	---	79.50	13.00	15 000.0	1 000.000	100.0	H	331.0	24.9
14 970.600	---	53.89	59.50	5.61	15 000.0	1 000.000	100.0	H	331.0	24.9
16 150.400	---	53.57	59.50	5.93	15 000.0	1 000.000	100.0	V	244.0	25.0
16 150.400	66.45	---	79.50	13.05	15 000.0	1 000.000	100.0	V	244.0	25.0
16 952.800	70.43	---	79.50	9.07	15 000.0	1 000.000	100.0	H	229.0	28.2
16 952.800	---	52.31	59.50	7.19	15 000.0	1 000.000	100.0	H	229.0	28.2
17 743.300	72.42	---	79.50	7.08	15 000.0	1 000.000	100.0	V	258.0	30.4
17 743.300	---	52.82	59.50	6.68	15 000.0	1 000.000	100.0	V	258.0	30.4

② 18 GHz ~ 30 GHz

1) Charging + IR Communication Mode

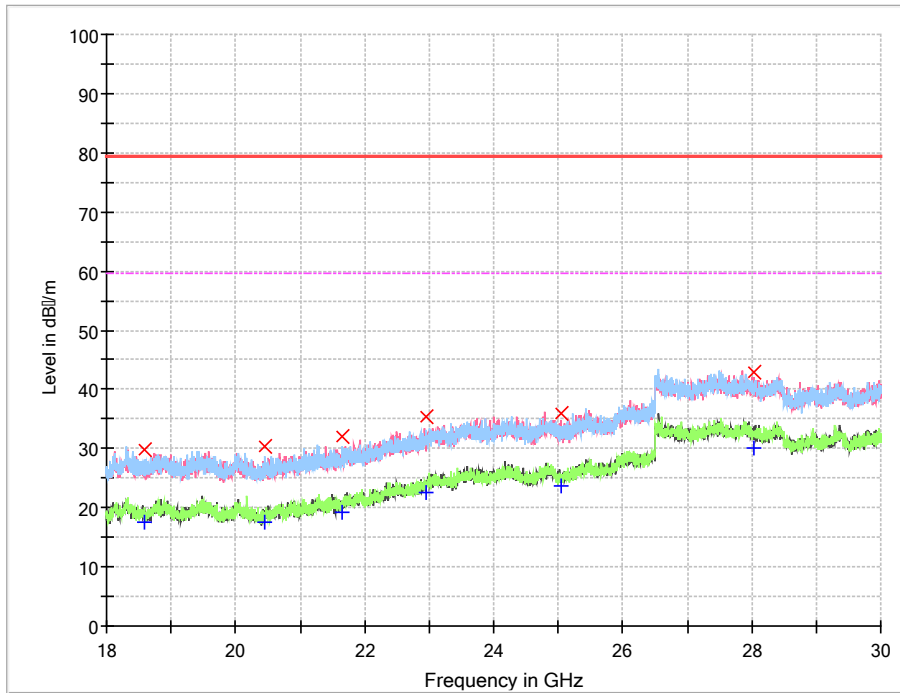

Final_Result

Frequency (MHz)	MaxPeak (dBµV/m)	CAverage (dBµV/m)	Limit (dBµV/m)	Margin (dB)	Meas. Time(ms)	Bandwidth (kHz)	Height (cm)	Pol	Azimuth (deg)	Corr. (dB)
18 580.800	29.93	---	79.50	49.57	15 000.0	1 000.000	100.0	H	122.0	-2.8
18 580.800	---	17.52	59.50	41.98	15 000.0	1 000.000	100.0	H	122.0	-2.8
20 461.800	30.27	---	79.50	49.23	15 000.0	1 000.000	100.0	H	101.0	-2.3
20 461.800	---	17.60	59.50	41.90	15 000.0	1 000.000	100.0	H	101.0	-2.3
21 654.200	---	19.35	59.50	40.15	15 000.0	1 000.000	100.0	H	7.0	-0.5
21 654.200	31.99	---	79.50	47.51	15 000.0	1 000.000	100.0	H	7.0	-0.5
22 954.400	---	22.45	59.50	37.05	15 000.0	1 000.000	100.0	H	175.0	2.3
22 954.400	35.43	---	79.50	44.07	15 000.0	1 000.000	100.0	H	175.0	2.3
25 035.600	35.91	---	79.50	43.59	15 000.0	1 000.000	100.0	V	102.0	2.8
25 035.600	---	23.57	59.50	35.93	15 000.0	1 000.000	100.0	V	102.0	2.8
28 040.800	---	30.16	59.50	29.34	15 000.0	1 000.000	100.0	V	236.0	4.8
28 040.800	42.82	---	79.50	36.68	15 000.0	1 000.000	100.0	V	236.0	4.8

2) Charging + RS-422 Communication Mode

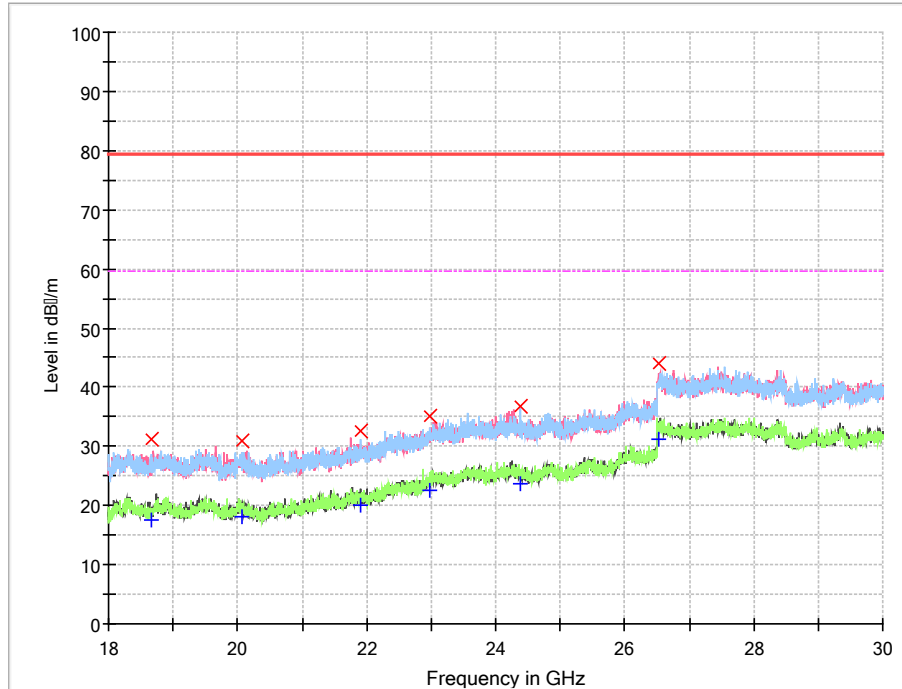

Final_Result

Frequency (MHz)	MaxPeak (dBμV/m)	CAverage (dBμV/m)	Limit (dBμV/m)	Margin (dB)	Meas. Time(ms)	Bandwidth (kHz)	Height (cm)	Pol	Azimuth (deg)	Corr. (dB)
18 666.600	31.21	---	79.50	48.29	15 000.0	1 000.000	100.0	H	232.0	-2.8
18 666.600	---	17.53	59.50	41.97	15 000.0	1 000.000	100.0	H	232.0	-2.8
20 072.400	---	18.21	59.50	41.29	15 000.0	1 000.000	100.0	V	183.0	-2.8
20 072.400	31.00	---	79.50	48.50	15 000.0	1 000.000	100.0	V	183.0	-2.8
21 911.600	---	20.13	59.50	39.37	15 000.0	1 000.000	100.0	H	308.0	-0.1
21 911.600	32.67	---	79.50	46.83	15 000.0	1 000.000	100.0	H	308.0	-0.1
22 987.400	---	22.67	59.50	36.83	15 000.0	1 000.000	100.0	H	0.0	2.3
22 987.400	35.20	---	79.50	44.30	15 000.0	1 000.000	100.0	H	0.0	2.3
24 388.800	36.66	---	79.50	42.84	15 000.0	1 000.000	100.0	H	0.0	3.4
24 388.800	---	23.76	59.50	35.74	15 000.0	1 000.000	100.0	H	0.0	3.4
26 536.000	---	31.19	59.50	28.31	15 000.0	1 000.000	100.0	V	335.0	5.2
26 536.000	43.89	---	79.50	35.61	15 000.0	1 000.000	100.0	V	335.0	5.2

3) Charging + Optical Communication Mode

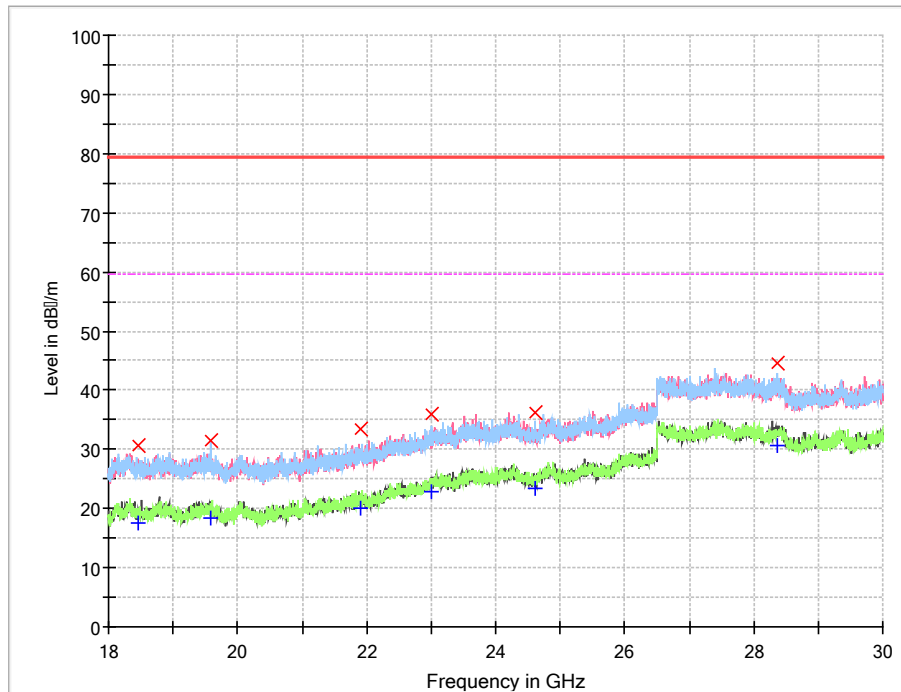

Final_Result

Frequency (MHz)	MaxPeak (dBμV/m)	CAverage (dBμV/m)	Limit (dBμV/m)	Margin (dB)	Meas. Time(ms)	Bandwidth (kHz)	Height (cm)	Pol	Azimuth (deg)	Corr. (dB)
18 451.000	30.55	---	79.50	48.95	15 000.0	1 000.000	100.0	H	138.0	-2.7
18 451.000	---	17.49	59.50	42.01	15 000.0	1 000.000	100.0	H	138.0	-2.7
19 581.800	31.39	---	79.50	48.11	15 000.0	1 000.000	100.0	H	68.0	-2.8
19 581.800	---	18.25	59.50	41.25	15 000.0	1 000.000	100.0	H	68.0	-2.8
21 902.800	33.43	---	79.50	46.07	15 000.0	1 000.000	100.0	H	38.0	-0.1
21 902.800	---	20.05	59.50	39.45	15 000.0	1 000.000	100.0	H	38.0	-0.1
23 016.000	35.85	---	79.50	43.65	15 000.0	1 000.000	100.0	H	239.0	2.4
23 016.000	---	22.89	59.50	36.61	15 000.0	1 000.000	100.0	H	239.0	2.4
24 608.800	36.23	---	79.50	43.27	15 000.0	1 000.000	100.0	H	261.0	3.2
24 608.800	---	23.41	59.50	36.09	15 000.0	1 000.000	100.0	H	261.0	3.2
28 362.000	44.47	---	79.50	35.03	15 000.0	1 000.000	100.0	H	261.0	4.9
28 362.000	---	30.68	59.50	28.82	15 000.0	1 000.000	100.0	H	261.0	4.9

Measurement Uncertainty : See Appendix A

Note : • AF = Antenna Factor

• POL H = Horizontal

• H = Height

• Corr. = AF + CL – AMP

• CL = Cable Loss

• POL V = Vertical

• Margin = Limit – Result

** The value of 'Level' includes 'Corr.'

• AMP = Amplifier Gain

• A = Angle

Ex) In case

Freq ; 100 MHz, level ; 30 dB(μV/m), AF ; 10 dB/m, CL ; 4 dB, Amp ; 25 dB

Result = Level + AF + CL – Amp

$$= 30 + 10 + 4 - 25$$

$$= 19$$

Margin = Limit – Result

$$= 43.5 - 19$$

$$= 24.5$$

Appendix A : Measurement Uncertainty

- Giheung Laboratory

Test Method		Measurement Uncertainty	
Conducted Emission		ENV216	3.7 dB (The confidential level is 95 %, $k=2$)
		ESH2-Z5	3.2 dB (The confidential level is 95 %, $k=2$)
		ESH3-Z6	3.2 dB (The confidential level is 95 %, $k=2$)
		NNLK8129	3.1 dB (The confidential level is 95 %, $k=2$)
Conducted Emission - Signal		ISN T800	5.4 dB (The confidential level is 95 %, $k=2$)
		ISN ST08	6.6 dB (The confidential level is 95 %, $k=2$)
Discontinuous		2.7 dB (The confidential level is 95 %, $k=2$)	
Radiated Emission	9 kHz ~30 MHz	Horizontal	3.3 dB (The confidential level is 95 %, $k=2$)
		Vertical	3.3 dB (The confidential level is 95 %, $k=2$)
	30 MHz ~ 1 000 MHz	Horizontal	4.3 dB (The confidential level is 95 %, $k=2$)
		Vertical	4.6 dB (The confidential level is 95 %, $k=2$)
	1 GHz ~ 18 GHz	Horizontal	3.9 dB (The confidential level is 95 %, $k=2$)
		Vertical	4.0 dB (The confidential level is 95 %, $k=2$)

- Gunpo Laboratory

Test Method		Measurement Uncertainty	
Conducted Emission		ENV216	4.0 dB (The confidential level is 95 %, $k=2$)
		ESH2-Z5	3.6 dB (The confidential level is 95 %, $k=2$)
		ESH3-Z6	3.8 dB (The confidential level is 95 %, $k=2$)
Conducted Emission - Signal		ISN T800	5.8 dB (The confidential level is 95 %, $k=2$)
		ISNT8-Cat6	5.8 dB (The confidential level is 95 %, $k=2$)
		ISN S751	7.5 dB (The confidential level is 95 %, $k=2$)
Disturbance Voltage at Antenna Terminal		2.9 dB (The confidential level is 95 %, $k=2$)	
Radiated Emission	9 kHz ~30 MHz	Horizontal	3.4 dB (The confidential level is 95 %, $k=2$)
		Vertical	3.4 dB (The confidential level is 95 %, $k=2$)
	30 MHz ~ 1 000 MHz	Horizontal	4.5 dB (The confidential level is 95 %, $k=2$)
		Vertical	5.1 dB (The confidential level is 95 %, $k=2$)
	1 GHz ~ 18 GHz	Horizontal	3.7 dB (The confidential level is 95 %, $k=2$)
		Vertical	3.9 dB (The confidential level is 95 %, $k=2$)

- Dongtan Laboratory

Test Method		Measurement Uncertainty	
Conducted Emission	ENV216	3.5 dB (The confidential level is 95 %, $k=2$)	
	ESH2-Z5	3.3 dB (The confidential level is 95 %, $k=2$)	
	ESH3-Z6	3.3 dB (The confidential level is 95 %, $k=2$)	
	NNLK8129	3.4 dB (The confidential level is 95 %, $k=2$)	
Conducted Emission - Signal	ISN T800	5.7 dB (The confidential level is 95 %, $k=2$)	
	ISN ST08	5.5 dB (The confidential level is 95 %, $k=2$)	
Discontinuous		2.9 dB (The confidential level is 95 %, $k=2$)	
disturbance Power		3.9 dB (The confidential level is 95 %, $k=2$)	
Radiated Emission	9 kHz ~30 MHz (Triple Loop Ant.)	3.4 dB (The confidential level is 95 %, $k=2$)	
	9 kHz ~30 MHz (Loop Ant.)	Horizontal	3.8 dB (The confidential level is 95 %, $k=2$)
		Vertical	3.8 dB (The confidential level is 95 %, $k=2$)
	30 MHz ~ 1 000 MHz	Horizontal	4.8 dB (The confidential level is 95 %, $k=2$)
		Vertical	5.4 dB (The confidential level is 95 %, $k=2$)
	1 GHz ~ 18 GHz	Horizontal	4.1 dB (The confidential level is 95 %, $k=2$)
Vertical		4.2 dB (The confidential level is 95 %, $k=2$)	

- End of Test Report -