



Parrot

Created by : <b>Sebastien LAVAL</b>	Reference <b>SLA-2008-001</b>	Title <b>CK5000New - Hands-Free Car Kit Modules Datasheet</b>
Revised by : <b>Sebastien LAVAL</b>	Date <b>05/09/2008</b>	edition N°: <b>1.02</b>
Approved by : <b>Fabien LEA</b>	Date <b>05/09/2008</b>	Function <b>OEM Program Manager</b>



Parrot

**CK5000New - Hands-Free Car Kit  
Modules Datasheet**



Created by : <b>Sebastien LAVAL</b>	Reference <b>SLA-2008-001</b>	Title <b>CK5000New - Hands-Free Car Kit Modules Datasheet</b>
Revised by : <b>Sebastien LAVAL</b>	Date <b>05/09/2008</b>	edition N°: <b>1.02</b>
Approved by : <b>Fabien LEA</b>	Date <b>05/09/2008</b>	Function <b>OEM Program Manager</b>

**HISTORY**

Rev	Date	Author	Description
0.9	28/12/2007	F. LEA	Add precision regarding Combo memory and RAM technology
0.91	09/01/2008	S.LAVAL	<ul style="list-style-type: none"> <li>- Refresh document layout</li> <li>- Review features list</li> <li>- Update block diagram §1.2</li> <li>- Add 26 MHz oscillator in §2.2</li> <li>- Remove Power Supply description on §2.4</li> <li>- Update external circuit in § 2.6: Replace LM4665 by op-amp stage</li> <li>- Update connector specification</li> </ul>
0.92	06/02/2008	S.LAVAL	- New description for software architecture
0.93	29/02/2008	S.LAVAL	- Mechanical design update
0.94	31/03/2008	S.LAVAL	- Connector pin out drawing review
0.95	16/04/2008	S.LAVAL	<ul style="list-style-type: none"> <li>- Add mechanical specification for horizontal module</li> <li>- Add motherboard integration for horizontal module</li> <li>- Start-up sequence update</li> <li>- Update mechanical specification for vertical module</li> <li>- Add FCC ID and legal notice</li> </ul>
1.00	29/08/2008	S.LAVAL	<ul style="list-style-type: none"> <li>- Update overall document format</li> <li>- Correct AC output level</li> <li>- Review § 4.5.3</li> </ul>
1.01	02/09/2008	S.LAVAL	- Revise §4.3
1.02	05/09/2008	S.LAVAL	<ul style="list-style-type: none"> <li>- Add CE Declaration</li> <li>- Update §6 BLUES description</li> <li>- Update §4.5.3.3</li> <li>- Update Absolute maximum ratings §4.3</li> </ul>

**REFERENCE DOCUMENTS**

N°	Reference	Rev	Title
[1]	PN		



Created by : <b>Sebastien LAVAL</b>	Reference <b>SLA-2008-001</b>	Title <b>CK5000New - Hands-Free Car Kit Modules Datasheet</b>
Revised by : <b>Sebastien LAVAL</b>	Date <b>05/09/2008</b>	edition N°: <b>1.02</b>
Approved by : <b>Fabien LEA</b>	Date <b>05/09/2008</b>	Function <b>OEM Program Manager</b>

**TABLE OF CONTENTS**

**1 PRODUCT OVERVIEW ..... 4**

1.1 CK5000NEW FEATURES ..... 4

1.2 CONFIGURATIONS ..... 5

**2 ELECTRICAL ARCHITECTURE..... 6**

2.1 BLOCK DIAGRAM..... 6

2.2 MAIN COMPONENTS ..... 7

**3 CONNECTOR PIN-OUT ..... 8**

**4 ELECTRICAL CHARACTERISTICS ..... 9**

4.1 POWER CONSUMPTION ..... 9

4.2 POWER SUPPLY..... 9

4.3 ABSOLUTE MAXIMUM RATINGS..... 9

4.4 BLUETOOTH RADIO LINK..... 9

4.5 ELECTRICAL SPECIFICATIONS ..... 9

    4.5.1 *UART interface* ..... 9

    4.5.2 *Reset* ..... 10

    4.5.3 *Audio Interface*..... 11

4.6 EXTERNAL DESIGN (ANALOG INTERFACE)..... 13

**5 MODULE LAYOUT .....14**

**6 SOFTWARE SPECIFICATIONS .....15**

6.1 SOFTWARE FUNCTIONALITIES ..... 15

6.2 SOFTWARE ARCHITECTURE ..... 16

**7 MECHANICAL CHARACTERISTICS .....17**

7.1 MECHANICAL SPECIFICATIONS – MODULE WITH PCB ANTENNA..... 17

    7.1.1 *Vertical version:* ..... 17

    7.1.2 *Horizontal version:*..... 18

    7.1.3 *Shield specifications:*..... 18

7.2 CONNECTOR SPECIFICATION: ..... 18

7.3 MOTHERBOARD INTEGRATION..... 19

    7.3.1 *Vertical module – Mechanical integration:*..... 19

    7.3.2 *Horizontal version – Mechanical integration:*..... 20

    7.3.3 *Mother board interface connector MOLEX 52465-1470:*..... 21

**8 APPROVALS / CERTIFICATIONS.....22**

8.1 BLUETOOTH QUALIFICATION..... 22

8.2 FCC / CE COMPLIANCE..... 22

    8.2.1 *CK5000New with internal BT antenna* ..... 22

    8.2.2 *CK5000New with external BT antenna* ..... 23

8.3 CE DECLARATION..... 23

8.4 ROHS DECLARATION ..... 23

**9 DEVELOPMENT TOOLS .....24**

Created by : <b>Sebastien LAVAL</b>	Reference <b>SLA-2008-001</b>	Title <b>CK5000New - Hands-Free Car Kit Modules Datasheet</b>
Revised by : <b>Sebastien LAVAL</b>	Date <b>05/09/2008</b>	edition N°: <b>1.02</b>
Approved by : <b>Fabien LEA</b>	Date <b>05/09/2008</b>	Function <b>OEM Program Manager</b>

## 1 PRODUCT OVERVIEW

---

This document is the Datasheet of the Parrot CK5000New Bluetooth Module.

The CK5000New is a feature-rich Bluetooth platform designed for the integration in car audios, car telematic systems or any systems requiring a complete embedded Bluetooth solution.

### 1.1 CK5000New Features

- Full Bluetooth Hands Free solution:
  - Phone call
  - Phone Book synchronisation
  - Message synchronisation
- Bluetooth:
  - Bluetooth Power Class2 Radio
  - Bluetooth specification v2.0
  - All profiles supported
  - Compatible with all Bluetooth phones
- Digital Signal Processing:
  - Acoustic Echo cancellation
  - Noise Reduction
  - Robust voice recognition for name dialling (speaker dependent)
- Compatibility Management:
  - Pairing and connection with all Bluetooth Devices: Phones, smartphones, PDA ...
  - Phone Book Synchronization with all devices.
  - Offer of numerous characters sets (European, Russian, Chinese, Japanese...)
- Hardware:
  - P4+ ASIC (64MHz core frequency)
  - Infineon Bluetooth chip PMB 8753
  - UART interface (up to 460800 bauds)
  - Internal crystal oscillator 26 MHz
  - Module dimensions: 28x 32.45mm
  - External interface: 14 pins board to board connector
  - Possibility of internal or external antenna



Created by : <b>Sebastien LAVAL</b>	Reference <b>SLA-2008-001</b>	Title <b>CK5000New - Hands-Free Car Kit Modules Datasheet</b>
Revised by : <b>Sebastien LAVAL</b>	Date <b>05/09/2008</b>	edition N°: <b>1.02</b>
Approved by : <b>Fabien LEA</b>	Date <b>05/09/2008</b>	Function <b>OEM Program Manager</b>

## 1.2 Configurations

Ordering Reference	Module Type
PF240015xx	CK5000New HIA
PF240016xx	CK5000New VIA
PF240017xx	CK5000New HEA
PF240018xx	CK5000New VEA

*HIA* : Horizontal version – Internal Antenna  
*HEA* : Horizontal version – External Antenna  
*VIA* : Vertical Version – Internal Antenna  
*VEA* : Vertical Version – External Antenna

Created by : <b>Sebastien LAVAL</b>	Reference <b>SLA-2008-001</b>	Title <b>CK5000New - Hands-Free Car Kit Modules Datasheet</b>
Revised by : <b>Sebastien LAVAL</b>	Date <b>05/09/2008</b>	edition N°: <b>1.02</b>
Approved by : <b>Fabien LEA</b>	Date <b>05/09/2008</b>	Function <b>OEM Program Manager</b>

## 2 ELECTRICAL ARCHITECTURE

### 2.1 Block diagram

The main electrical interfaces provided by the CK5000New are:

- Audio:
  - 1 audio input (analogical)
  - 1 audio output (analogical)
- Serial Link:
  - UART for the software interface through AT commands (refer to [1])
- Power Supply:
  - 3.3V

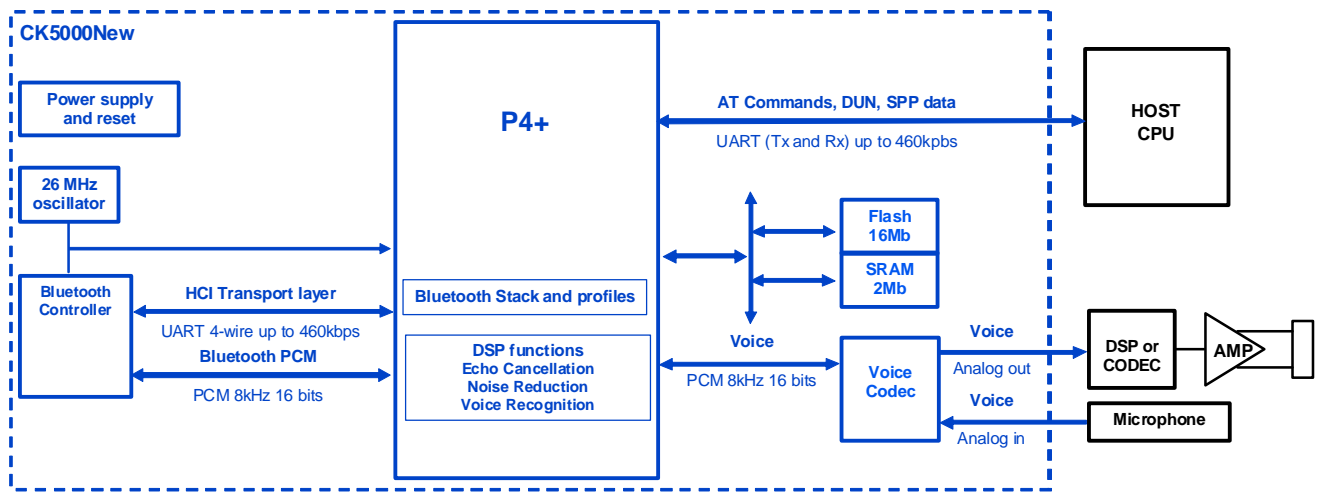

CK5000New block diagram

Created by : <b>Sebastien LAVAL</b>	Reference <b>SLA-2008-001</b>	Title <b>CK5000New - Hands-Free Car Kit Modules Datasheet</b>
Revised by : <b>Sebastien LAVAL</b>	Date <b>05/09/2008</b>	edition N°: <b>1.02</b>
Approved by : <b>Fabien LEA</b>	Date <b>05/09/2008</b>	Function <b>OEM Program Manager</b>

## 2.2 Main components

The main components are:

- Parrot4+ ASIC
- Bluetooth module Infineon PMB8753
- Combo Ram/Flash : 2 Mbits or 4Mbits SRAM memory & 16 Mbits flash memory
- Codec : 16 bits PCM 8kHz audio codec for converting audio signals between analog and digital formats
- 26 MHZ oscillator
- BT antenna: 2 different configurations available (on PCB F-inverted Antenna or coaxial connector for remote antenna).

Created by : Sebastien LAVAL	Reference SLA-2008-001	Title <b>CK5000New - Hands-Free Car Kit Modules Datasheet</b>
Revised by : Sebastien LAVAL	Date 05/09/2008	edition N°: 1.02
Approved by : Fabien LEA	Date 05/09/2008	Function OEM Program Manager

### 3 CONNECTOR PIN-OUT

The following pin-out allows an interface to the CK5000New according to market standards:

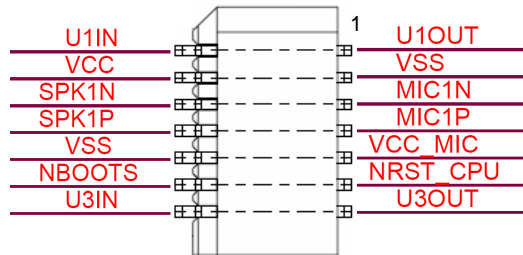

14 pins connector

PIN	FUNCTION	INPUT / OUTPUT / POWER	TYPICAL VOLTAGE	MAXIMAL CURRENT	COMMENT
1	U1OUT	O	3.3V	10mA	16C550 Compatible type (for Flash Update interface and host AT commands)
2	U1IN	I	3.3V	1mA	
3	VSS	P	0V	1A	GROUND
4	VCC	P	3.3V ( $\pm 0.1V$ )	1 A	
5	MIC1N	I	0V	15mA	Analogical audio input
6	SPK1N	O	1.65V (2)	10mA	Analogical audio output
7	MIC1P	I	2.5V (2)	1mA	Analogical audio input
8	SPK1P (3)	O	1.65V (2)	10mA	Analogical audio output
9	VCC_MIC	P	3.3V	1mA	Microphone bias voltage
10	VSS	P	0V	1A	GROUND
11	NRST_CPU (1)	I	3.3V	3mA	RESET trigger Input
12	NBOOTS	I	3.3V	1mA	Flash update
13	U3OUT	O	3.3V	10mA	16C550 Compatible type (for Debug interface)
14	U3IN	I	3.3V	1mA	

Notes:

1) Internal pull up.

2) Mean value.

3) SPK Output pins are differential outputs with  $V_{cc}/2$  mean value.



Created by : Sebastien LAVAL	Reference SLA-2008-001	Title <b>CK5000New - Hands-Free Car Kit Modules Datasheet</b>
Revised by : Sebastien LAVAL	Date 05/09/2008	edition N°: 1.02
Approved by : Fabien LEA	Date 05/09/2008	Function OEM Program Manager

## 4 ELECTRICAL CHARACTERISTICS

### 4.1 Power consumption

The CK5000New features two different operating modes allowing low-power consumption:

Operating modes	Current	Comment
standby mode	<40 mA	BT module in park/sniff mode , Parrot4+ ASIC in idle
active mode	<200 mA	All components active

### 4.2 Power supply

DC input supply voltage.....3.3V (±0.1V)

Maximum allowed ripple.....30 mV rms

Peak current: 1A during 1.2ms during switch ON.

### 4.3 Absolute maximum ratings

Operating temperature range.....-40°C to +85°C

Storage temperature range.....-20°C to +50°C

Non-operating temperature range.....-40°C to +125°C

DC input supply voltage range.....3.2V to 3.6V

ESD sensitivity according to IEC610000-4-2.....±2KV

### 4.4 Bluetooth Radio link

The module is optionally equipped with internal PCB antenna or a connector for external antenna.

The line impedance from RF output to connector (over Bluetooth frequency range) is 50 Ohm.

### 4.5 Electrical specifications

#### 4.5.1 UART interface

UART 1 and 3 are 16C550 Compatible Type.

- Default transmission speed is 115200bps, max speed is 460800 bps
- A bit "Start Bit=0" is added to the beginning of each word (8bits).
- A "Stop Bit=1" is sent by the transmitter at the end of each word.
- No parity

Created by : <b>Sebastien LAVAL</b>	Reference <b>SLA-2008-001</b>	Title <b>CK5000New - Hands-Free Car Kit Modules Datasheet</b>
Revised by : <b>Sebastien LAVAL</b>	Date <b>05/09/2008</b>	edition N°: <b>1.02</b>
Approved by : <b>Fabien LEA</b>	Date <b>05/09/2008</b>	Function <b>OEM Program Manager</b>

- The Least Significant Bit (LSB) is sent first

<b>UART1 / UART3</b>					
	<b>Min</b>	<b>Typ</b>	<b>Max</b>	<b>Unit</b>	<b>Comment</b>
Input High Level	2.5	--	Vcc	V	NC
Input Low Level	--	--	0.5	V	NC
Output High Level	Vcc-0.3	--	N/A	V	at IOH = 0,1mA (open collector with build-in 2,5k pull-up)
Output Low Level	--	--	0.4	V	at IOL = 2mA
Rise Time versus Load Capacitance for Output	--	1300	1900	ns	C = 100 pF
Fall Time versus Load Capacitance for Output	--	240	350	ns	C = 100 pF

#### 4.5.2 Reset

Asynchronous reset signal used to reset the module, active low.

<b>RESET</b>					
	<b>Min</b>	<b>Typ</b>	<b>Max</b>	<b>Unit</b>	<b>Comment</b>
Reset Time	50	--	--	µs	NC
Active Level	--	--	0.2	V	NC
Non Active Level	2.5	--	N/A	V	NC

The Switching ON and OFF procedures are described below.

##### 4.5.2.1 *Switch ON sequence:*

The signal "NRST\_CPU" on the host interface is forced to a logical zero value by host until the supply voltage reached its nominal value.

- The host switches its signal "NRST\_CPU" to a logical one value allowing the module to turn on its supply.
- After 280ms, the power supply is stabilized and then triggers the start of the ASIC

##### 4.5.2.2 *Switch OFF sequence:*

- The host sends the "sleep" AT command: AT\*POFF [1].
- The ASIC disconnects any BT link.
- The ASIC sends the "sleep acknowledgement" AT event and then stops the UART link [1].
- The host switches the reset to a zero logical value.

If the host switches the "NRST\_CPU" to zero level for at least 5 µs but no more than 4ms the module will be reset.

Created by : <b>Sebastien LAVAL</b>	Reference <b>SLA-2008-001</b>	Title <b>CK5000New - Hands-Free Car Kit Modules Datasheet</b>
Revised by : <b>Sebastien LAVAL</b>	Date <b>05/09/2008</b>	edition N°: <b>1.02</b>
Approved by : <b>Fabien LEA</b>	Date <b>05/09/2008</b>	Function <b>OEM Program Manager</b>

### 4.5.3 Audio Interface

#### 4.5.3.1 *Microphone interface*

The below schematic details internal microphone stage:

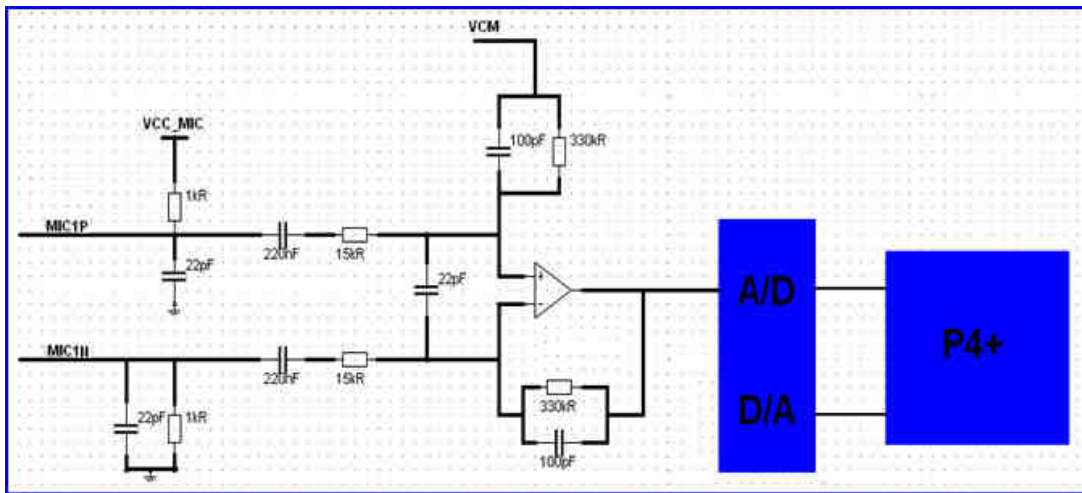

CK5000New is designed to be used with an electret condenser microphone with impedance less than 2.2kOhms.

Recommended electrical characteristics of the microphone:

- Operating voltage: 1.5V-3.6V DC
- Current consumption: 500µA max.
- Use of pre-amplified microphones is in option.

#### 4.5.3.2 *Microphone power supply*

Supply voltage 3.3V for microphone.

Decoupling capacitor required on main board (470µF – 6V3 with ESR<10 ohm at low temperature)

#### 4.5.3.3 *Characteristics*

AUDIO Input (Analogical)					
	Min	Typ	Max	Unit	Comment
Input Impedance	TBD	TBD	2200	Ohm	NC
DC Input Voltage (BIAS Voltage)	TBD	2.5	TBD		NC
Common Mode Rejection Ratio @1kHz	30	TBD	--	dB	NC
Signal To Noise Ratio (THD + N)/S	TBD	TBD	--	dB	NC
High Cut Frequency (-3dB)	--	3.4	--	kHz	NC
Low Cut Frequency (-3dB)	--	200	--	Hz	NC



Created by : <b>Sebastien LAVAL</b>	Reference <b>SLA-2008-001</b>	Title <b>CK5000New - Hands-Free Car Kit Modules Datasheet</b>
Revised by : <b>Sebastien LAVAL</b>	Date <b>05/09/2008</b>	edition N°: <b>1.02</b>
Approved by : <b>Fabien LEA</b>	Date <b>05/09/2008</b>	Function <b>OEM Program Manager</b>

#### 4.5.3.4 Speaker interface

SPK1N and SPK1P are differential outputs capable of driving a 1kOhms load with 2.94V peak-to-peak.

The signal mean value is  $V_{cc}/2$ .

AUDIO Output (Analogical)					
	Min	Typ	Max	Unit	Comment
Drive Load Capability	1000	--	--	Ohm	NC
AC Output Level	--	--	0.85	V rms	NC
DC output voltage	$V_{cc}/2 - 0.2$	$V_{cc}/2$	$V_{cc}/2 + 0.2$	V	NC
THD	--	TBD	TBD	%	NC
High Cut Frequency (-3dB)	--	3.6	--	kHz	NC
Low Cut Frequency (-3dB)	--	200	--	Hz	NC
Out Put Noise	--	TBD	TBD	$\mu$ V	NC
Signal To Noise Ratio	--	TBD	--	dB	NC
Power Supply Rejection	--	TBD	--	dB	NC

Created by : <b>Sebastien LAVAL</b>	Reference <b>SLA-2008-001</b>	Title <b>CK5000New - Hands-Free Car Kit Modules Datasheet</b>
Revised by : <b>Sebastien LAVAL</b>	Date <b>05/09/2008</b>	edition N°: <b>1.02</b>
Approved by : <b>Fabien LEA</b>	Date <b>05/09/2008</b>	Function <b>OEM Program Manager</b>

## 4.6 External design (analog interface)

Audio Pins SPK1P, SPK1N, MIC1P and MIC1N must be protected from noise.

Isolate U1IN, U1OUT, U3IN, U3OUT, SPK1P, SPK1N, MIC1P, MIC1N, NRST\_CPU and VSS by 0R resistors (RF: 0603) and use ferrites in case of EMC disturbances.

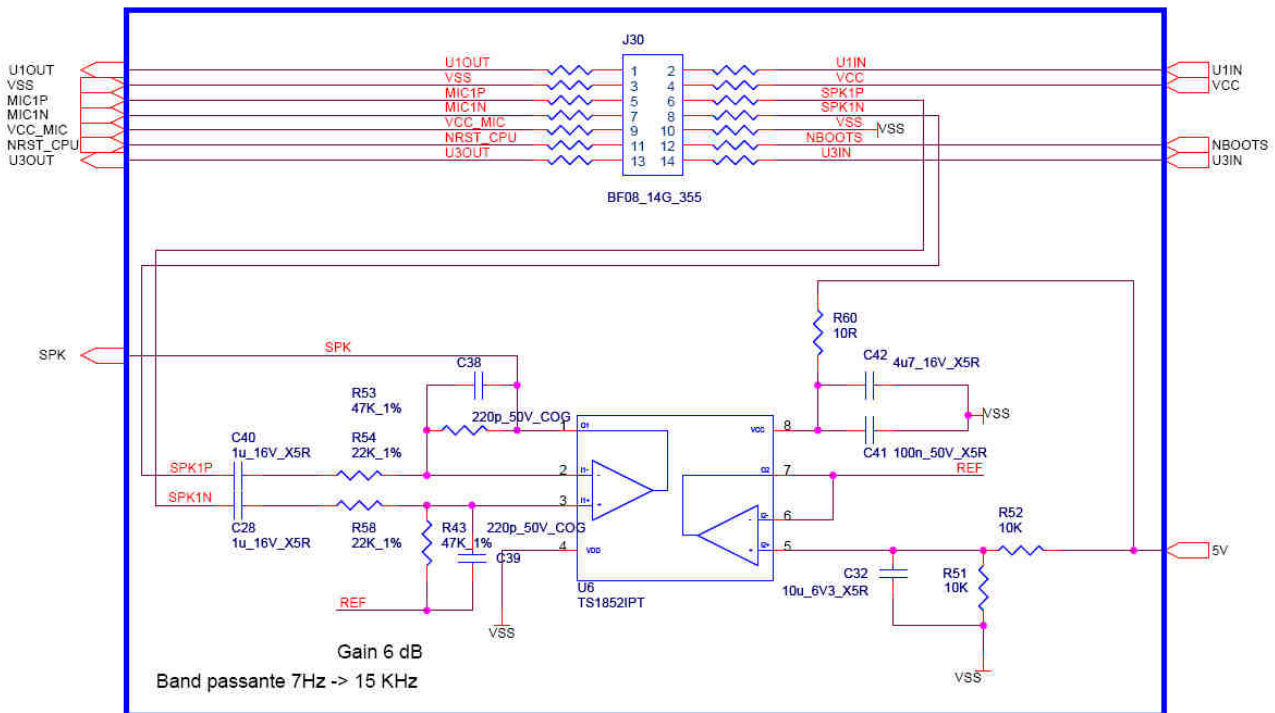

Example of audio stage interface on host board

Created by : <b>Sebastien LAVAL</b>	Reference <b>SLA-2008-001</b>	Title <b>CK5000New - Hands-Free Car Kit Modules Datasheet</b>
Revised by : <b>Sebastien LAVAL</b>	Date <b>05/09/2008</b>	edition N°: <b>1.02</b>
Approved by : <b>Fabien LEA</b>	Date <b>05/09/2008</b>	Function <b>OEM Program Manager</b>

## 5 MODULE LAYOUT

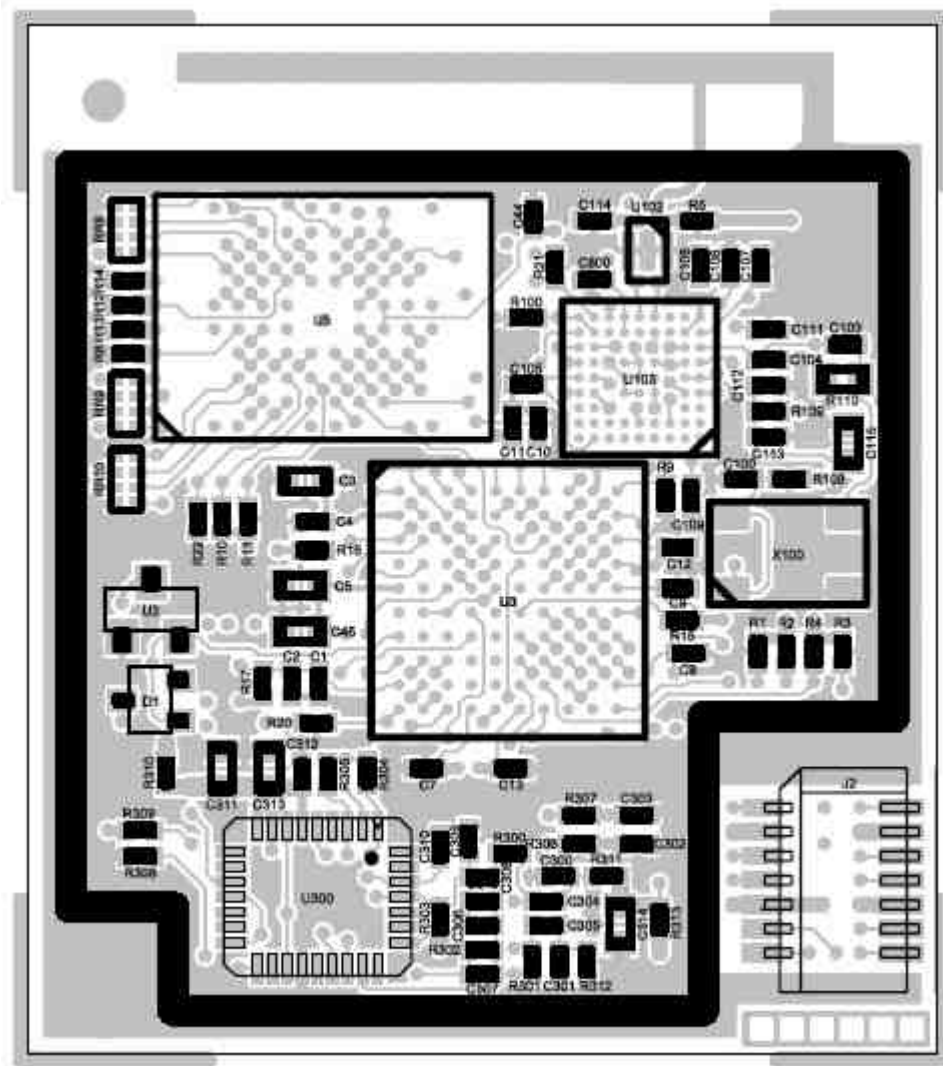

Created by : Sebastien LAVAL	Reference SLA-2008-001	Title <b>CK5000New - Hands-Free Car Kit Modules Datasheet</b>
Revised by : Sebastien LAVAL	Date 05/09/2008	edition N°: 1.02
Approved by : Fabien LEA	Date 05/09/2008	Function OEM Program Manager

## 6 SOFTWARE SPECIFICATIONS

### Bluetooth Stack

- HCI (Host Controller interface),
- L2CAP (Logical Link Control and Adaptation Protocol),
- RFCOMM (TS011...),
- SDP (Service Discovery Protocol),
- OBEX (IrDA Object Exchange).



### Bluetooth Profiles Supported

BLUES 2.0
<b>Generic Access Profile</b> GAP
<b>Phone Management</b> HFP 0.96 - 1.0 - 1.5 HSP 1.0
<b>Phone Book</b> PBAP 1.0 SYNC 1.1 (IrMC SYNC over BT) OPP 1.0 Server/Client (Vcard 2.1) GSM 07.07 AT Commands Nokia synchronization protocol
<b>Others</b> SPP 1.1 DUNP 1.1 Software update over SPP

### 6.1 Software Functionalities

The main target of the software interface is to provide a high level command set, hiding the internal complexity of the Bluetooth function and the variability of its standard across different devices.

This software interface is based on well-known AT commands. Some of these commands are directly derived from the GSM 07.07 recommendation and from the appropriate Bluetooth profiles.

Some supplementary commands are used to manage Bluetooth related functions like device pairing and connection management as well as the acoustic and speech recognition functions.

AT commands are detailed in [1].

Created by : Sebastien LAVAL	Reference SLA-2008-001	Title <b>CK5000New - Hands-Free Car Kit Modules Datasheet</b>
Revised by : Sebastien LAVAL	Date 05/09/2008	edition N°: 1.02
Approved by : Fabien LEA	Date 05/09/2008	Function OEM Program Manager

## 6.2 Software Architecture

CK5000New software architecture can be decomposed as showed on the diagram below.

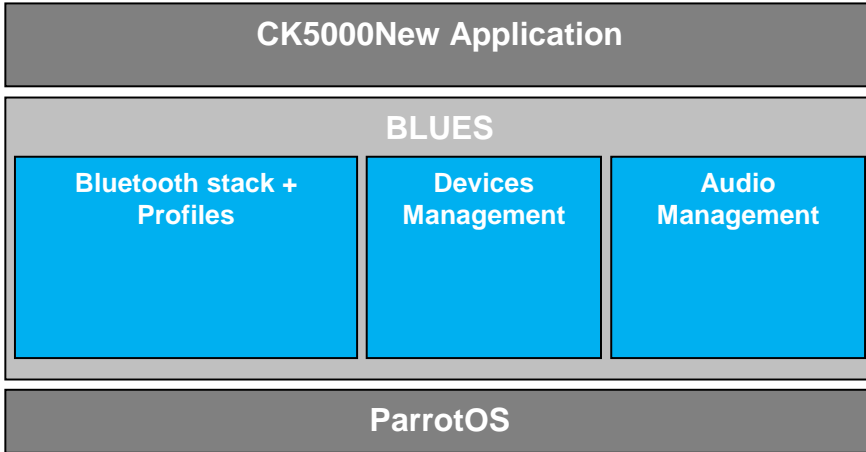

BLUES supports Unicode, which allows the management of accents and phonebook in any language. It has also a friendly and flexible MMI. One can use BLUES with a simple single or double key interface as well as a diversity of graphic displays.

For information, here is a description of Bluetooth stack and Bluetooth profiles in BLUES.

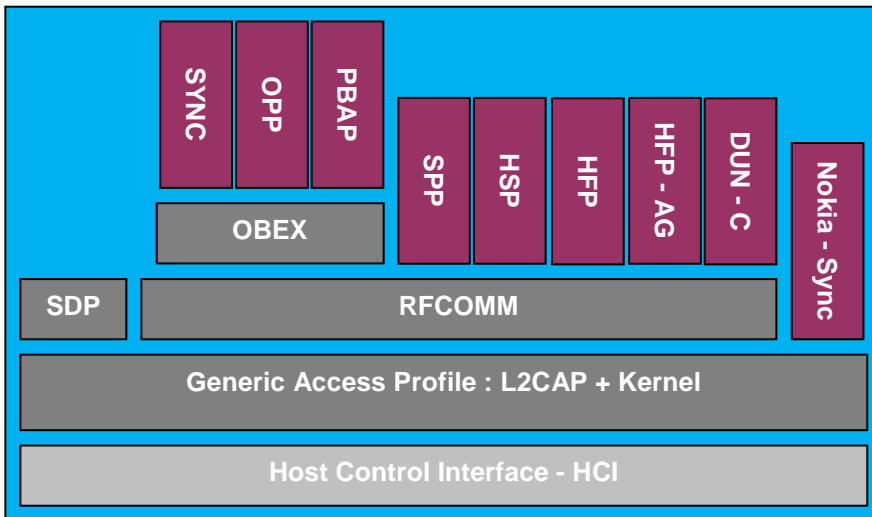



Created by : <b>Sebastien LAVAL</b>	Reference <b>SLA-2008-001</b>	Title <b>CK5000New - Hands-Free Car Kit Modules Datasheet</b>
Revised by : <b>Sebastien LAVAL</b>	Date <b>05/09/2008</b>	edition N°: <b>1.02</b>
Approved by : <b>Fabien LEA</b>	Date <b>05/09/2008</b>	Function <b>OEM Program Manager</b>

## 7 MECHANICAL CHARACTERISTICS

The CK5000New features a female connector allowing a connection to the motherboard through a male connector.

The CK5000New exists in two mechanical configurations, with either a vertical or a horizontal mounting onto the mother board. Each mechanical configuration is realised by the mounting of a specific PCB shield and the appropriate 14 pins connector.

For both version fixation to the mother board is assured by the PCB shield.

### 7.1 Mechanical specifications – module with PCB antenna

These dimensions are stated on a preliminary basis.

#### 7.1.1 Vertical version:

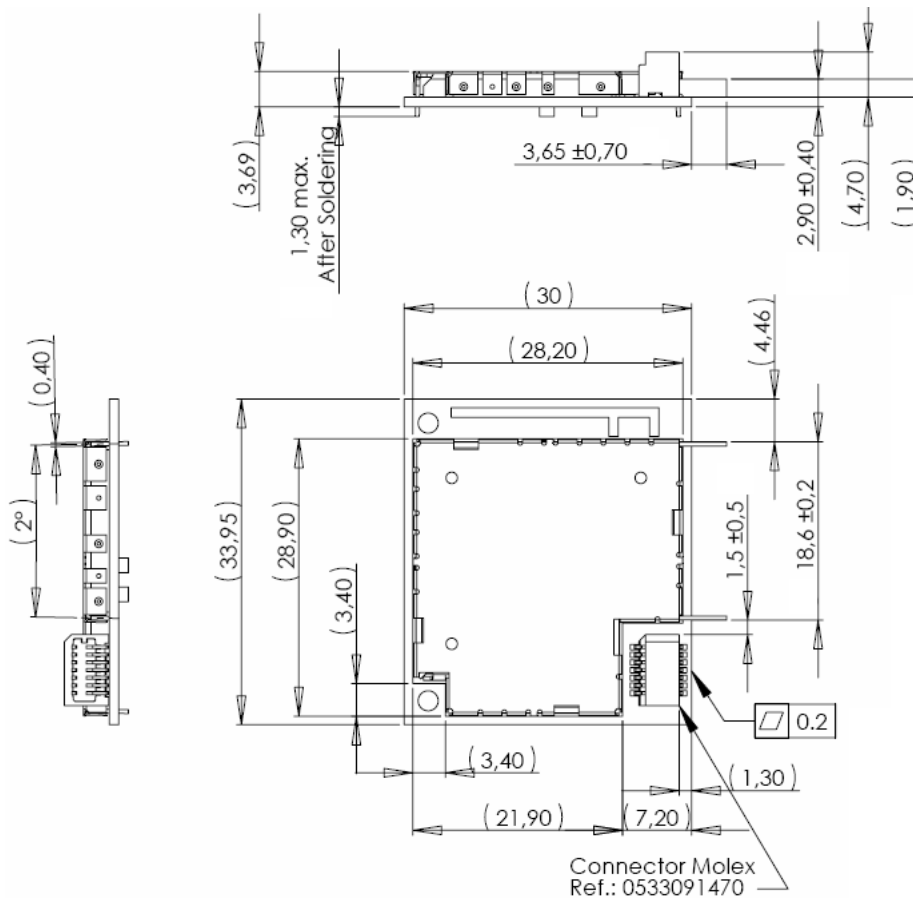

Created by : Sebastien LAVAL	Reference SLA-2008-001	Title <b>CK5000New - Hands-Free Car Kit Modules Datasheet</b>
Revised by : Sebastien LAVAL	Date 05/09/2008	edition N°: 1.02
Approved by : Fabien LEA	Date 05/09/2008	Function OEM Program Manager

7.1.2 Horizontal version:

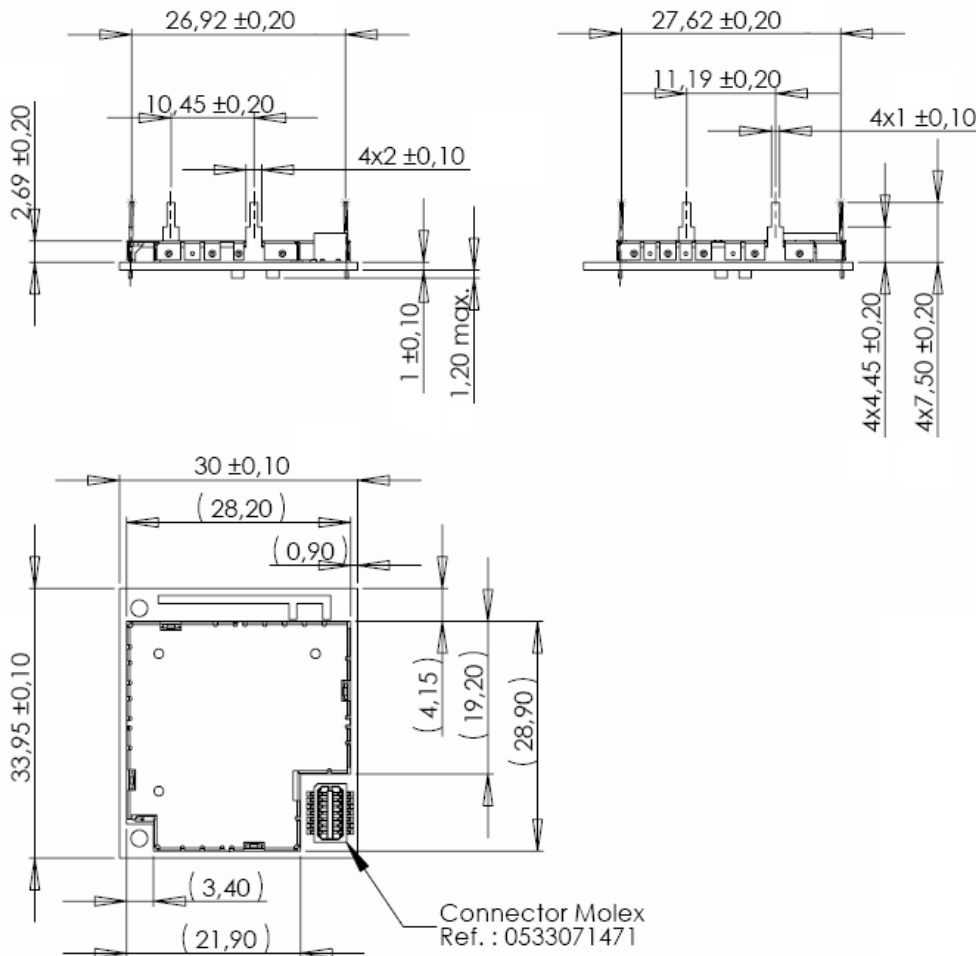

7.1.3 Shield specifications:

For vertical version, refer to annex documents: PAR\_ME0040-B-080625.pdf and PAR\_ME0041-B-080625.pdf.

For horizontal version, refer to annex documents: CK5000NEW Frame2 19004197\_P7.pdf and PAR\_ME0041-B-080625.pdf

**7.2 Connector specification:**

Respectively vertical and horizontal versions of the CK5000New module mount interface connector: MOLEX 053309-1470 and MOLEX 053307-1471.

Datasheets are proposed as annexe documents.

Created by : <b>Sebastien LAVAL</b>	Reference <b>SLA-2008-001</b>	Title <b>CK5000New - Hands-Free Car Kit Modules Datasheet</b>
Revised by : <b>Sebastien LAVAL</b>	Date <b>05/09/2008</b>	edition N°: <b>1.02</b>
Approved by : <b>Fabien LEA</b>	Date <b>05/09/2008</b>	Function <b>OEM Program Manager</b>

## 7.3 Motherboard Integration

Mechanical constraints for the integration on the mother board are detailed below.

### 7.3.1 Vertical module – Mechanical integration:

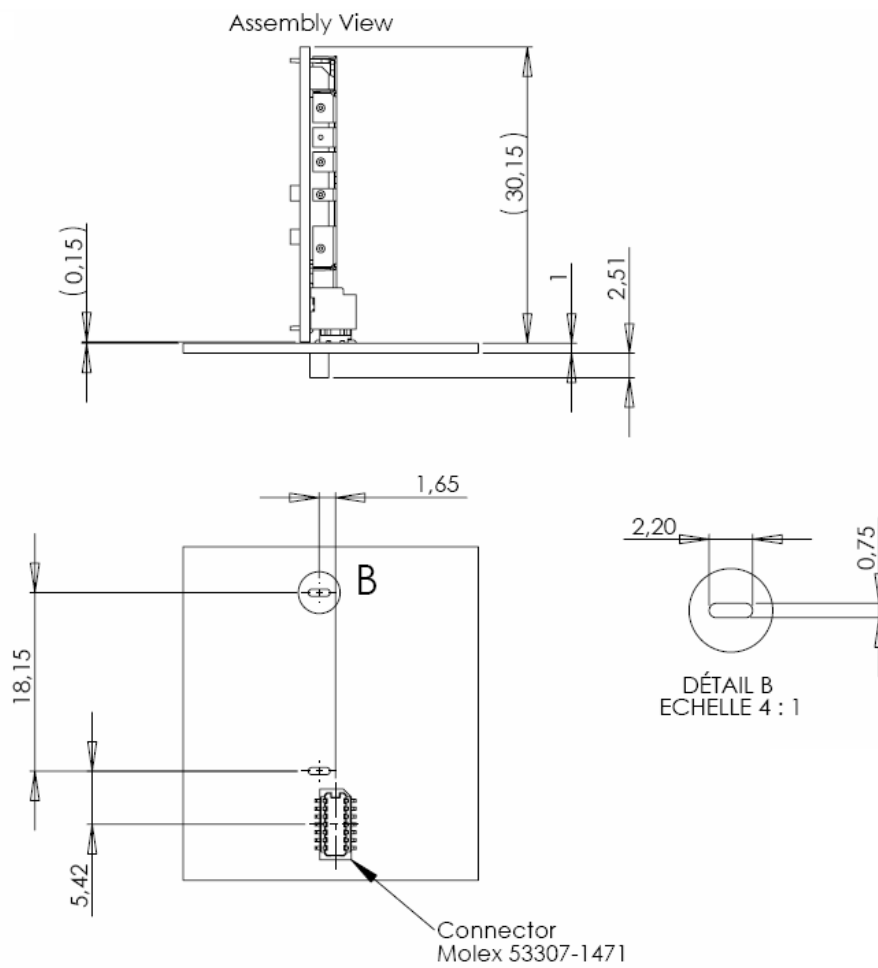

Created by : <b>Sebastien LAVAL</b>	Reference <b>SLA-2008-001</b>	Title <b>CK5000New - Hands-Free Car Kit Modules Datasheet</b>
Revised by : <b>Sebastien LAVAL</b>	Date <b>05/09/2008</b>	edition N°: <b>1.02</b>
Approved by : <b>Fabien LEA</b>	Date <b>05/09/2008</b>	Function <b>OEM Program Manager</b>

7.3.2 Horizontal version – Mechanical integration:

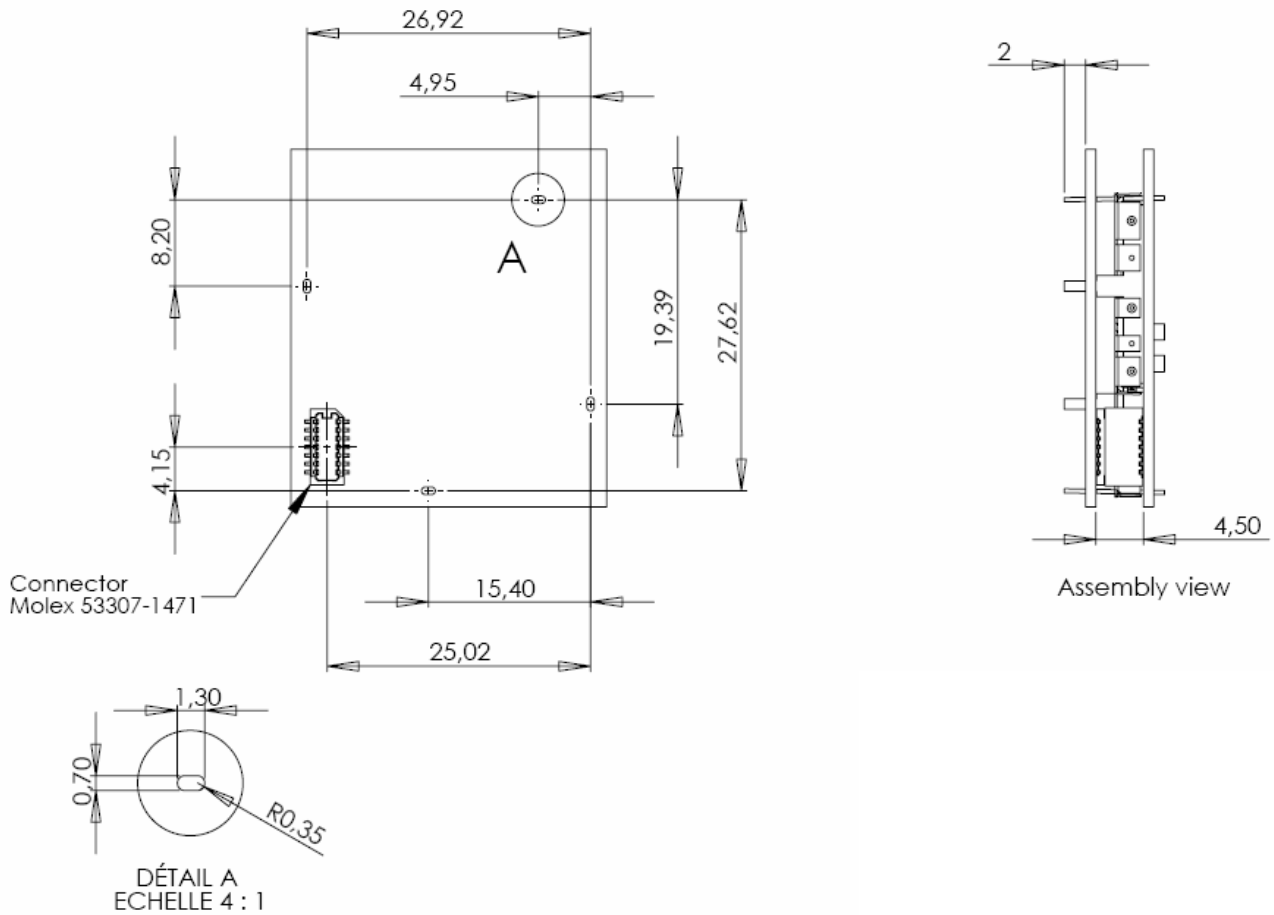

Created by : <b>Sebastien LAVAL</b>	Reference <b>SLA-2008-001</b>	Title <b>CK5000New - Hands-Free Car Kit Modules Datasheet</b>
Revised by : <b>Sebastien LAVAL</b>	Date <b>05/09/2008</b>	edition N°: <b>1.02</b>
Approved by : <b>Fabien LEA</b>	Date <b>05/09/2008</b>	Function <b>OEM Program Manager</b>

7.3.3 Mother board interface connector MOLEX 52465-1470:

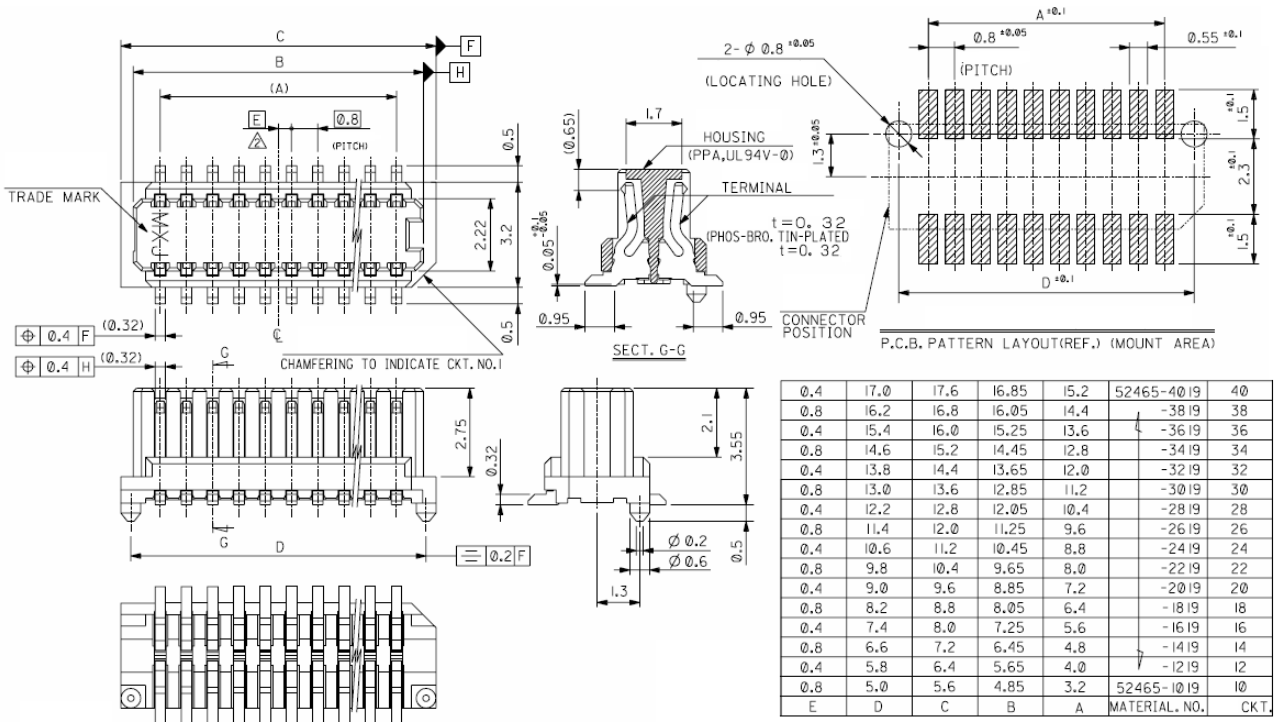



Created by : Sebastien LAVAL	Reference SLA-2008-001	Title <b>CK5000New - Hands-Free Car Kit Modules Datasheet</b>
Revised by : Sebastien LAVAL	Date 05/09/2008	edition N°: 1.02
Approved by : Fabien LEA	Date 05/09/2008	Function OEM Program Manager

## 8 APPROVALS / CERTIFICATIONS

---

### 8.1 BLUETOOTH Qualification

To be completed after product qualification.

### 8.2 FCC / CE Compliance

#### 8.2.1 CK5000New with internal BT antenna

FCC ID: RKXCK5000N VIA

In accordance with FCC Part 15, the CK5000New is listed as a Limited Modular Transmitter device.

In support of the Modular Transmitter Approval, the following is stated:

- The module does have buffered modulation / data inputs.
- The module have a permanently attached antenna.
- The module have its own RF shielding
- The module can be tested as a stand-alone device.
- The module is labeled with the proper FCC ID, and labeling instructions are provided to OEM end users for external product labels.
- The module does have instruction for proper use.
- The module does meet the FCC RF regulations.

Limited Modular Transmitter Approval, is granted, instead of Modular Transmitter Approval, because the following condition is not met:

- The module does not have to regulate its own power supply.

Module CK5000New is labelled with its own FCC number on its shielding, and, if the FCC ID is not visible when the module is installed inside final device, then the outside of the device into which the module is installed must also display a label referring to the enclosed module. This exterior label can use wording such as the following: "Contains Transmitter Module FCC ID: RKXCK5000N VIA" or "Contains FCC ID: RKXCK5000N VIA." Any similar wording that expresses the same meaning may be used.

Module CK5000New can not be integrated in a final device which is connected to the AC power lines. It is necessary that final device must be supplied by a battery.

FCC RF exposure requirements: This device and its antenna(s) must not be collocated or operating in conjunction with any other antenna or transmitter.

THIS DEVICE COMPLIES WITH PART 15 OF THE FCC RULES. OPERATION IS SUBJECT TO THE FOLLOWING TWO CONDITIONS:

- (1) THIS DEVICE MAY NOT CAUSE HARMFUL INTERFERENCE, AND



Created by : <b>Sebastien LAVAL</b>	Reference <b>SLA-2008-001</b>	Title <b>CK5000New - Hands-Free Car Kit Modules Datasheet</b>
Revised by : <b>Sebastien LAVAL</b>	Date <b>05/09/2008</b>	edition N°: <b>1.02</b>
Approved by : <b>Fabien LEA</b>	Date <b>05/09/2008</b>	Function <b>OEM Program Manager</b>

(2) THIS DEVICE MUST ACCEPT ANY INTERFERENCE RECEIVED, INCLUDING INTERFERENCE THAT MAY CAUSE UNDESIRE OPERATION.

NOTE: THE MANUFACTURER IS NOT RESPONSIBLE FOR ANY RADIO OR TV INTERFERENCE CAUSED BY UNAUTHORIZED MODIFICATIONS TO THIS EQUIPMENT. SUCH MODIFICATIONS COULD VOID THE USER'S AUTHORITY TO OPERATE THE EQUIPMENT.

### 8.2.2 CK5000New with external BT antenna

CK5000New with external antenna is not submitted to FCC and CE marks. Moreover, there is no "fixed" configuration: cable (between module and antenna) and BT antenna characteristics. These 2 elements have an impact on the EMC performances. Also, environment around the module (car radio) is an important factor. So, FCC and CE qualifications must be done with the whole product (car radio + CK5000New)

## 8.3 CE Declaration

We, Parrot SA 174 quai de Jemmapes 75010 Paris France, declare under our sole responsibility that our product (Parrot CK5050+) is in conformity with the Radio and Telecommunication equipment directive 1999/5/EC R&TTE according to the essentials requirements and respect the norms listed below:

<b>3.1-a) Electrical Safety</b>	<b>EN60950-1</b>
<b>EMF</b>	<b>EN50371</b>
<b>3.1-b) EMC</b>	<b>EN301 489-17</b>
<b>3.2 Radio</b>	<b>EN300 328</b>

Paris, September the 2nd, 2008

Qualification Manager

Arezki Guerrab

## 8.4 ROHS Declaration

To be completed.



Created by : <b>Sebastien LAVAL</b>	Reference <b>SLA-2008-001</b>	Title <b>CK5000New - Hands-Free Car Kit Modules Datasheet</b>
Revised by : <b>Sebastien LAVAL</b>	Date <b>05/09/2008</b>	edition N°: <b>1.02</b>
Approved by : <b>Fabien LEA</b>	Date <b>05/09/2008</b>	Function <b>OEM Program Manager</b>

## 9 DEVELOPMENT TOOLS

---

To be released.