



FCC TEST REPORT

REPORT NO.: RF930309R02
MODEL NO.: WM1270
RECEIVED: Mar. 9, 2004
TESTED: Mar. 11 ~ Mar. 19, 2004

APPLICANT: CastleNet Technology Inc.

ADDRESS: 16F, No. 957, Chung Cheng Road,
Cuhung-Ho City, Taipei Hsien, Taiwan,
R.O.C.

ISSUED BY: Advance Data Technology Corporation

LAB LOCATION: 47 14th Lin, Chiapau Tsun, Linko, Taipei,
Taiwan, R.O.C.

This test report consists of 66 pages in total. It may be duplicated completely for legal use with the approval of the applicant. It should not be reproduced except in full, without the written approval of our laboratory. The client should not use it to claim product endorsement by CNLA or any government agencies. The test results in the report only apply to the tested sample.



0528
ILAC MRA



Table of Contents

1	CERTIFICATION	4
2	SUMMARY OF TEST RESULTS	5
3	GENERAL INFORMATION	6
3.1	GENERAL DESCRIPTION OF EUT	6
3.2	DESCRIPTION OF TEST MODES	7
3.3	GENERAL DESCRIPTION OF APPLIED STANDARDS	7
3.4	DESCRIPTION OF SUPPORT UNITS	8
3.5	CONFIGURATION OF SYSTEM UNDER TEST	8
4	TEST TYPES AND RESULTS	9
4.1	CONDUCTED EMISSION MEASUREMENT	9
4.1.1	LIMITS OF CONDUCTED EMISSION MEASUREMENT	9
4.1.2	TEST INSTRUMENTS	9
4.1.3	TEST PROCEDURES	10
4.1.4	DEVIATION FROM TEST STANDARD	10
4.1.5	TEST SETUP	11
4.1.6	EUT OPERATING CONDITIONS	11
4.1.7	TEST RESULTS	12
4.2	RADIATED EMISSION MEASUREMENT	18
4.2.1	LIMITS OF RADIATED EMISSION MEASUREMENT	18
4.2.2	TEST INSTRUMENTS	19
4.2.3	TEST PROCEDURES	20
4.2.4	DEVIATION FROM TEST STANDARD	20
4.2.5	TEST SETUP	21
4.2.6	EUT OPERATING CONDITIONS	21
4.2.7	TEST RESULTS	22
4.3	6dB BANDWIDTH MEASUREMENT	30
4.3.1	LIMITS OF 6dB BANDWIDTH MEASUREMENT	30
4.3.2	TEST INSTRUMENTS	30
4.3.3	TEST PROCEDURE	30
4.3.4	DEVIATION FROM TEST STANDARD	30



4.3.5 TEST SETUP 30

4.3.6 EUT OPERATING CONDITIONS 30

4.3.7 TEST RESULTS 31

4.4 MAXIMUM PEAK OUTPUT POWER 39

4.4.1 LIMITS OF MAXIMUM PEAK OUTPUT POWER MEASUREMENT 39

4.4.2 TEST INSTRUMENTS 39

4.4.3 TEST PROCEDURES 40

4.4.4 DEVIATION FROM TEST STANDARD 40

4.4.5 TEST SETUP 40

4.4.6 EUT OPERATING CONDITIONS 40

4.4.7 TEST RESULTS 41

4.5 POWER SPECTRAL DENSITY MEASUREMENT 42

4.5.1 LIMITS OF POWER SPECTRAL DENSITY MEASUREMENT 42

4.5.2 TEST INSTRUMENTS 42

4.5.3 TEST PROCEDURE 42

4.5.4 DEVIATION FROM TEST STANDARD 42

4.5.5 TEST SETUP 42

4.5.6 EUT OPERATING CONDITIONS 42

4.5.7 TEST RESULTS 43

4.6 BAND EDGES MEASUREMENT 51

4.6.1 LIMITS OF BAND EDGES MEASUREMENT 51

4.6.2 TEST INSTRUMENTS 51

4.6.3 TEST PROCEDURE 51

4.6.4 DEVIATION FROM TEST STANDARD 51

4.6.5 EUT OPERATING CONDITION 51

4.6.6 TEST RESULTS 52

4.7 ANTENNA REQUIREMENT 61

4.7.1 STANDARD APPLICABLE 61

4.7.2 ANTENNA CONNECTED CONSTRUCTION 61

5 PHOTOGRAPHS OF THE TEST CONFIGURATION 62

6 INFORMATION ON THE TESTING LABORATORIES 66



1 CERTIFICATION

PRODUCT : Wireless 802.11g MiniPCI Card
MODEL NO.: WM1270
BRAND: CastleNet
APPLICANT : CastleNet Technology Inc.
TEST ITEM: ENGINEERING SAMPLE
STANDARDS : FCC Part 15, Subpart C (Section 15.247),
ANSI C63.4-1992

We, **Advance Data Technology Corporation**, hereby certify that one sample of the designation has been tested in our facility from Mar. 11 to Mar. 19, 2004. The test record, data evaluation and Equipment Under Test (EUT) configurations represented herein are true and accurate accounts of the measurements of the sample's EMC characteristics under the conditions herein specified.

PREPARED BY: Suntee Liu , **DATE:** March 25, 2004
Suntee Liu
APPROVED BY: Ellis Wu , **DATE:** March 25, 2004
Ellis Wu /
Technical Manager



2 SUMMARY OF TEST RESULTS

The EUT has been tested according to the following specifications:

APPLIED STANDARD: FCC Part 15, Subpart C			
Standard Section	Test Type and Limit	Result	REMARK
15.207	AC Power Conducted Emission	PASS	Meet the requirement of limit Minimum passing margin is -21.09dB at 0.177MHz
15.247(a)(2)	Spectrum Bandwidth of a Direct Sequence Spread Spectrum System Limit : min. 500kHz	PASS	Meet the requirement of limit
15.247(b)	Maximum Peak Output Power Limit: max. 30dBm	PASS	Meet the requirement of limit
15.247(c)	Transmitter Radiated Emissions Limit: Table 15.209	PASS	Meet the requirement of limit Minimum passing margin is -1.02dB at 4924.00MHz
15.247(d)	Power Spectral Density Limit: max. 8dBm	PASS	Meet the requirement of limit
15.247(c)	Band Edge Measurement Limit: 20 dB less than the peak value of fundamental frequency	PASS	Meet the requirement of limit

NOTE: The information of measurement uncertainty is available upon the customer's request.



3 GENERAL INFORMATION

3.1 GENERAL DESCRIPTION OF EUT

PRODUCT	Wireless 802.11g MiniPCI Card
MODEL NO.	WM1270
POWER SUPPLY	3.3Vdc from host equipment
MODULATION TYPE	BPSK, QPSK, CCK, 16QAM, 64QAM
RADIO TECHNOLOGY	DSSS, OFDM
TRANSFER RATE	802.11b: 11/5.5/2/1Mbps 802.11g: 54/48/36/24/18/12/9/6Mbps
FREQUENCY RANGE	2412MHz ~ 2462MHz
NUMBER OF CHANNEL	11
MAXIMUM OUTPUT POWER	17.53dBm
ANTENNA TYPE	Dipole antenna with 2dBi antenna gain
DATA CABLE	NA
I/O PORTS	NA
ASSOCIATED DEVICES	NA

NOTE:

1. The EUT operates in the 2.4GHz frequency spectrum with throughput of up to 54Mbps.
2. The EUT complies with IEEE 802.11g draft standards and backwards compatible with IEEE 802.11b products.
3. For a more detailed features description, please refer to the manufacturer's specifications or User's Manual.



3.2 DESCRIPTION OF TEST MODES

Eleven channels are provided to this EUT.

Channel	Frequency	Channel	Frequency
1	2412 MHz	7	2442 MHz
2	2417 MHz	8	2447 MHz
3	2422 MHz	9	2452 MHz
4	2427 MHz	10	2457 MHz
5	2432 MHz	11	2462 MHz
6	2437 MHz		

NOTE:

1. Below 1GHz, the channel 1, 6, and 11 were pre-tested in chamber. The channel 11, worst case one, was chosen for final test.
2. Above 1GHz, the channel 1, 6, and 11 were tested individually.
3. Transfer rate, 11Mbps with CCK technique and 6Mbps with OFDM technique, the worst cases, were chosen for final test.
4. There are two test modes presented in the report. One is for CCK technique and another is for OFDM technique.

3.3 GENERAL DESCRIPTION OF APPLIED STANDARDS

The EUT is a Wireless 802.11g MiniPCI Card. According to the specifications of the manufacturer, it must comply with the requirements of the following standards:

FCC Part 15, Subpart C. (15.247)

ANSI C63.4 : 1992

All test items have been performed and recorded as per the above standards.

NOTE: The EUT is also considered as a kind of computer peripheral, because the connection to computer is necessary for typical use. It has been verified to comply with the requirements of FCC Part 15, Subpart B, Class B (DoC). The test report has been issued separately.



3.4 DESCRIPTION OF SUPPORT UNITS

The EUT has been tested as an independent unit together with other necessary accessories or support units. The following support units or accessories were used to form a representative test configuration during the tests.

NO.	PRODUCT	BRAND	MODEL NO.	SERIAL NO.	FCC ID
1	NOTEBOOK	DELL	D500	NA	FCC DoC Approved
2	PRINTER	EPSON	LQ-300+	DCGY017058	FCC DoC Approved
3	MODEM	ACEEX	1414	980020516	IFAXDM1414

NO.	SIGNAL CABLE DESCRIPTION OF THE ABOVE SUPPORT UNITS
1	NA
2	1.2m braid shielded wire, terminated with DB25 and Centronics connector via metallic frame, w/o core
3	1.2 m braid shielded wire, terminated with DB25 and DB9 connector via metallic frame, w/o core.

NOTE: All power cords of the above support units are non shielded (1.8m).

3.5 CONFIGURATION OF SYSTEM UNDER TEST

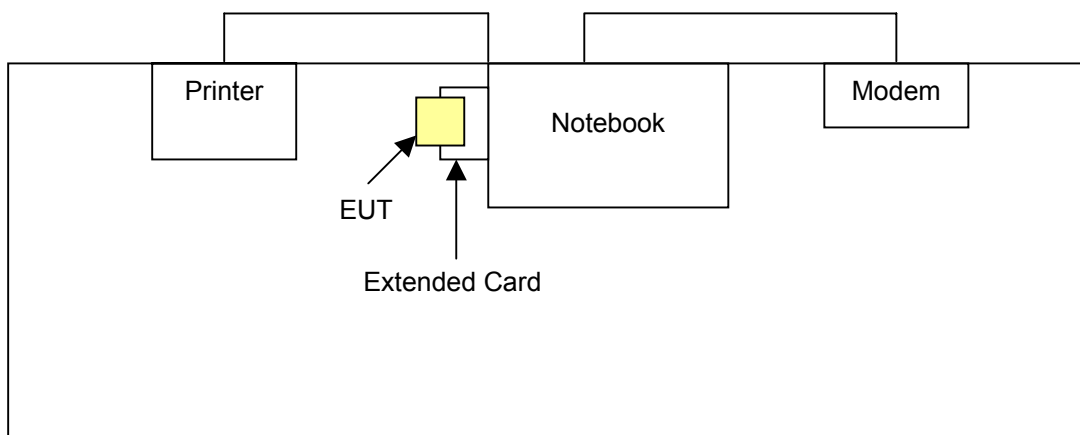



4 TEST TYPES AND RESULTS

4.1 CONDUCTED EMISSION MEASUREMENT

4.1.1 LIMITS OF CONDUCTED EMISSION MEASUREMENT

FREQUENCY OF EMISSION (MHz)	CONDUCTED LIMIT (dB μ V)	
	Quasi-peak	Average
0.15-0.5	66 to 56	56 to 46
0.5-5	56	46
5-30	60	50

- NOTE:**
1. The lower limit shall apply at the transition frequencies.
 2. The limit decreases in line with the logarithm of the frequency in the range of 0.15 to 0.50 MHz.
 3. All emanations from a class A/B digital device or system, including any network of conductors and apparatus connected thereto, shall not exceed the level of field strengths specified above.

4.1.2 TEST INSTRUMENTS

DESCRIPTION & MANUFACTURER	MODEL NO.	SERIAL NO.	CALIBRATED UNTIL
ROHDE & SCHWARZ Test Receiver	ESCS 30	838251/021	Jan. 04, 2005
ROHDE & SCHWARZ Artificial Mains Network (for EUT)	ESH3-Z5	100218	Dec. 09, 2004
ROHDE & SCHWARZ Artificial Mains Network (for peripherals)	ESH3-Z5	100219	Dec. 09, 2004
ROHDE & SCHWARZ Artificial Mains Network (for peripherals)	ESH3-Z5	100220	Dec. 09, 2004
*ROHDE & SCHWARZ 4-wire ISN	ENY41	837032/016	Nov. 19, 2004
*ROHDE & SCHWARZ 2-wire ISN	ENY22	837497/016	Nov. 19, 2004
Software	Cond-V2M3	NA	NA
RF cable (JYEBAO)	5D-FB	Cable-C10.01	May 01, 2004
SUHNER Terminator (For ROHDE & SCHWARZ LISN)	65BNC-5001	E1-010770	Feb. 28, 2005
SUHNER Terminator (For ROHDE & SCHWARZ LISN)	65BNC-5001	E1-010773	Apr. 06, 2004

- NOTE:**
1. The calibration interval of the above test instruments is 12 months and the calibrations are traceable to NML/ROC and NIST/USA.
 2. “*”: These equipment are used for conducted telecom port test only (if tested).
 3. The test was performed in ADT Shielded Room No. 10.
 4. The VCCI Site Registration No. is C-1312.



4.1.3 TEST PROCEDURES

- a. The EUT was placed 0.4 meters from the conducting wall of the shielded room with EUT being connected to the power mains through a line impedance stabilization network (LISN). Other support units were connected to the power mains through another LISN. The two LISNs provide 50 ohm/ 50uH of coupling impedance for the measuring instrument.
- b. Both lines of the power mains connected to the EUT were checked for maximum conducted interference.
- c. The frequency range from 150kHz to 30MHz was searched. Emission levels under (Limit -20dB) was not recorded.

4.1.4 DEVIATION FROM TEST STANDARD

No deviation

4.1.5 TEST SETUP

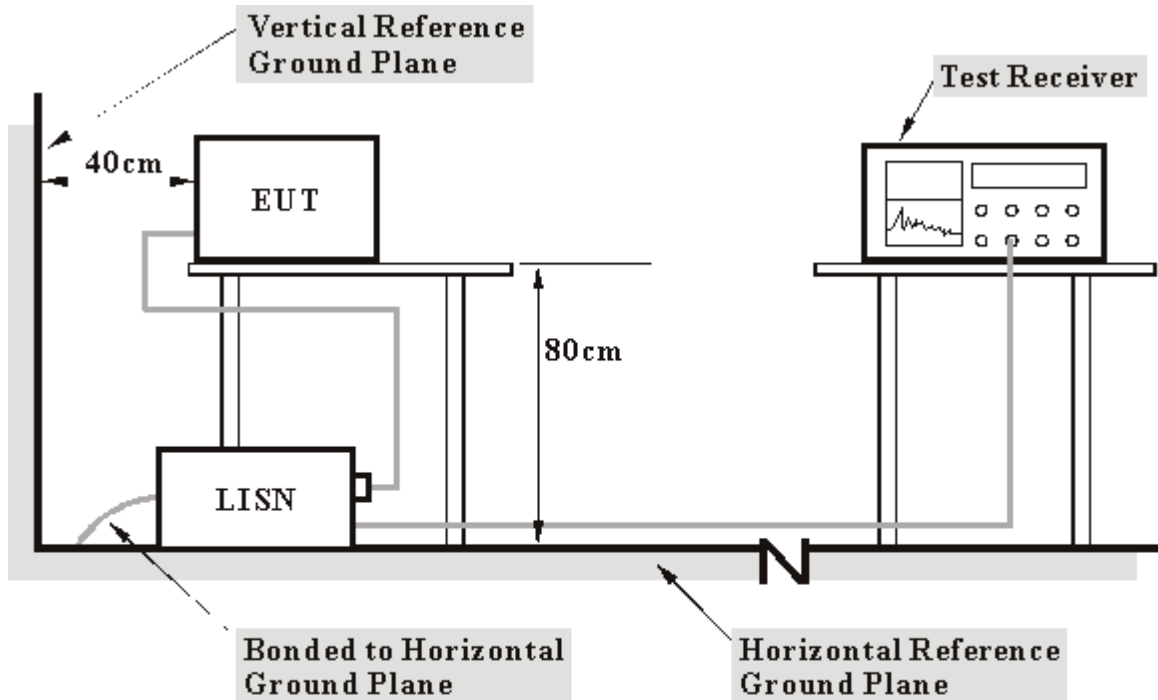

- Note:**
1. Support units were connected to second LISN.
 2. Both of LISNs (AMN) 80 cm from EUT and at the least 80 cm from other units and other metal planes support units.

For the actual test configuration, please refer to the related item – Photographs of the Test Configuration.

4.1.6 EUT OPERATING CONDITIONS

- a. Plug the EUT a notebook system placed on a testing table.
- b. The notebook system ran a test program (provided by manufacturer) to enable EUT under transmission/receiving condition continuously at specific channel frequency.
- c. The notebook system sent "H" messages to its screen.
- d. The notebook system sent "H" messages to modem.
- e. The notebook system sent "H" messages to printer, and the printer prints them on paper.
- f. Steps c~e were repeated.



4.1.7 TEST RESULTS

EUT	Wireless 802.11g MiniPCI Card	MODEL	WM1270
CHANNEL	1	6dB BANDWIDTH	9kHz
INPUT POWER (SYSTEM)	120Vac, 60Hz	PHASE	Line (L)
ENVIRONMENTAL CONDITIONS	20deg. C, 75%RH, 991hPa	TESTED BY: Jamison Chan	

No	Freq. [MHz]	Corr. Factor (dB)	Reading Value		Emission Level		Limit		Margin	
			[dB (uV)]		[dB (uV)]		[dB (uV)]		(dB)	
			Q.P.	AV.	Q.P.	AV.	Q.P.	AV.	Q.P.	AV.
1	0.150	0.10	43.49	-	43.59	-	66.00	56.00	-22.41	-
2	0.201	0.10	38.13	-	38.23	-	63.58	53.58	-25.35	-
3	0.283	0.10	34.81	-	34.91	-	60.73	50.73	-25.82	-
4	0.341	0.10	34.69	-	34.79	-	59.17	49.17	-24.38	-
5	0.865	0.18	28.94	-	29.12	-	56.00	46.00	-26.88	-
6	9.504	0.58	35.77	-	36.35	-	60.00	50.00	-23.65	-

- REMARKS:**
1. Q.P. and AV. are abbreviations of quasi-peak and average individually.
 2. "-": The Quasi-peak reading value also meets average limit and measurement with the average detector is unnecessary.
 3. The emission levels of other frequencies were very low against the limit.
 4. Margin value = Emission level - Limit value
 5. Correction factor = Insertion loss + Cable loss
 6. Emission Level = Correction Factor + Reading Value.

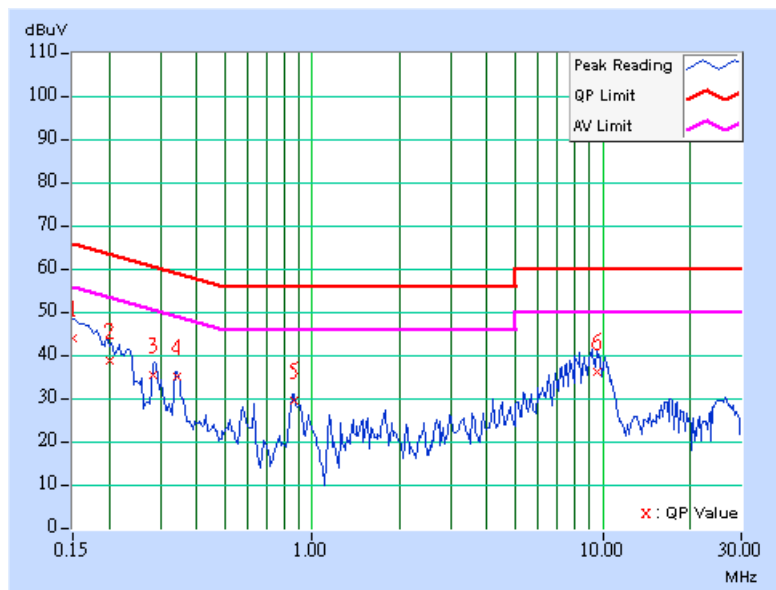



EUT	Wireless 802.11g MiniPCI Card	MODEL	WM1270
CHANNEL	1	6dB BANDWIDTH	9kHz
INPUT POWER (SYSTEM)	120Vac, 60Hz	PHASE	Neutral (N)
ENVIRONMENTAL CONDITIONS	20deg. C, 75%RH, 991hPa	TESTED BY: Jamison Chan	

No	Freq. [MHz]	Corr. Factor (dB)	Reading Value		Emission Level		Limit		Margin	
			[dB (uV)]		[dB (uV)]		[dB (uV)]		(dB)	
			Q.P.	AV.	Q.P.	AV.	Q.P.	AV.	Q.P.	AV.
1	0.150	0.10	43.91	-	44.01	-	66.00	56.00	-21.99	-
2	0.197	0.10	40.09	-	40.19	-	63.74	53.74	-23.55	-
3	0.287	0.10	38.27	-	38.37	-	60.62	50.62	-22.25	-
4	0.908	0.18	26.74	-	26.92	-	56.00	46.00	-29.08	-
5	8.008	0.43	34.11	-	34.54	-	60.00	50.00	-25.46	-
6	9.531	0.48	36.57	-	37.05	-	60.00	50.00	-22.95	-

- REMARKS:**
1. Q.P. and AV. are abbreviations of quasi-peak and average individually.
 2. "-": The Quasi-peak reading value also meets average limit and measurement with the average detector is unnecessary.
 3. The emission levels of other frequencies were very low against the limit.
 4. Margin value = Emission level - Limit value
 5. Correction factor = Insertion loss + Cable loss
 6. Emission Level = Correction Factor + Reading Value.

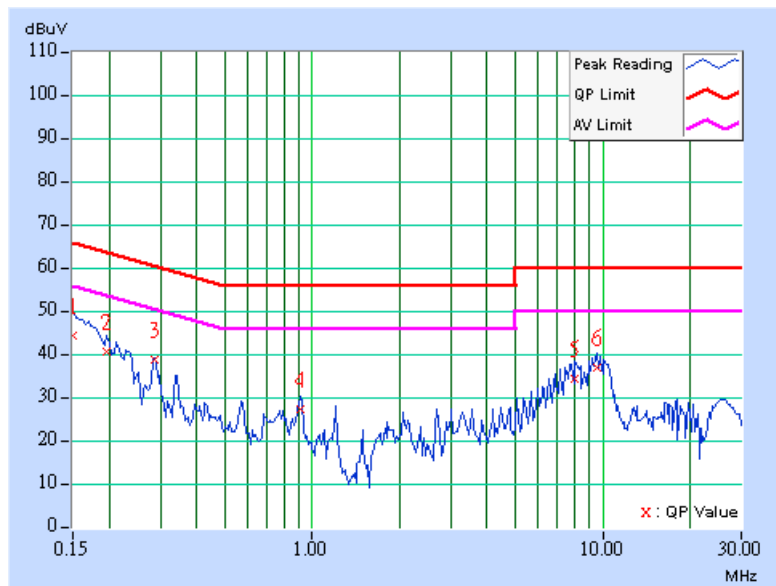



EUT	Wireless 802.11g MiniPCI Card	MODEL	WM1270
CHANNEL	6	6dB BANDWIDTH	9kHz
INPUT POWER (SYSTEM)	120Vac, 60Hz	PHASE	Line (L)
ENVIRONMENTAL CONDITIONS	20deg. C, 75%RH, 991hPa	TESTED BY: Jamison Chan	

No	Freq. [MHz]	Corr. Factor (dB)	Reading Value [dB (uV)]		Emission Level [dB (uV)]		Limit [dB (uV)]		Margin (dB)	
			Q.P.	AV.	Q.P.	AV.	Q.P.	AV.	Q.P.	AV.
			1	0.150	0.10	43.85	-	43.95	-	66.00
2	0.197	0.10	39.79	-	39.89	-	63.74	53.74	-23.85	-
3	0.228	0.10	36.02	-	36.12	-	62.52	52.52	-26.40	-
4	0.287	0.10	37.54	-	37.64	-	60.62	50.62	-22.98	-
5	0.341	0.10	34.67	-	34.77	-	59.17	49.17	-24.40	-
6	9.230	0.56	36.07	-	36.63	-	60.00	50.00	-23.37	-

- REMARKS:**
1. Q.P. and AV. are abbreviations of quasi-peak and average individually.
 2. "-": The Quasi-peak reading value also meets average limit and measurement with the average detector is unnecessary.
 3. The emission levels of other frequencies were very low against the limit.
 4. Margin value = Emission level - Limit value
 5. Correction factor = Insertion loss + Cable loss
 6. Emission Level = Correction Factor + Reading Value.

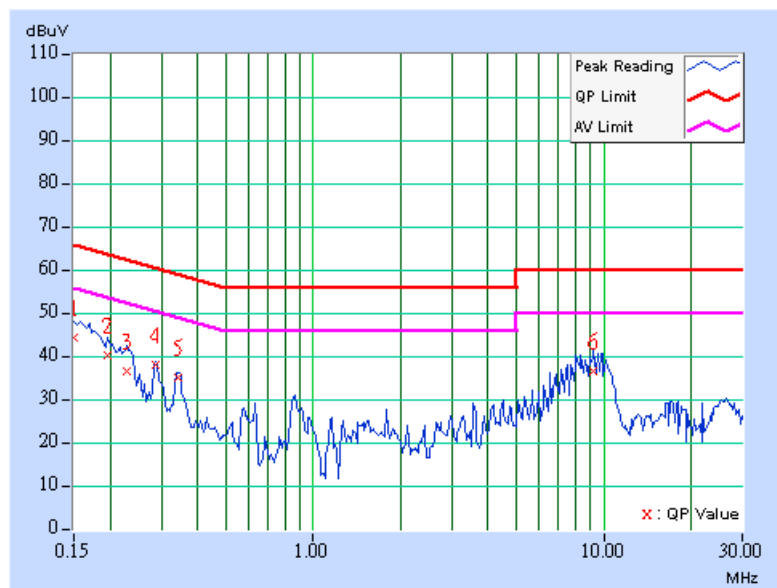



EUT	Wireless 802.11g MiniPCI Card	MODEL	WM1270
CHANNEL	6	6dB BANDWIDTH	9kHz
INPUT POWER (SYSTEM)	120Vac, 60Hz	PHASE	Neutral (N)
ENVIRONMENTAL CONDITIONS	20deg. C, 75%RH, 991hPa	TESTED BY: Jamison Chan	

No	Freq. [MHz]	Corr. Factor (dB)	Reading Value [dB (uV)]		Emission Level [dB (uV)]		Limit [dB (uV)]		Margin (dB)	
			Q.P.	AV.	Q.P.	AV.	Q.P.	AV.	Q.P.	AV.
			1	0.150	0.10	43.75	-	43.85	-	66.00
2	0.173	0.10	42.00	-	42.10	-	64.79	54.79	-22.69	-
3	0.224	0.10	33.22	-	33.32	-	62.66	52.66	-29.34	-
4	0.287	0.10	38.25	-	38.35	-	60.62	50.62	-22.27	-
5	8.336	0.44	33.41	-	33.85	-	60.00	50.00	-26.15	-
6	9.832	0.49	36.78	-	37.27	-	60.00	50.00	-22.73	-

- REMARKS:**
1. Q.P. and AV. are abbreviations of quasi-peak and average individually.
 2. "-": The Quasi-peak reading value also meets average limit and measurement with the average detector is unnecessary.
 3. The emission levels of other frequencies were very low against the limit.
 4. Margin value = Emission level - Limit value
 5. Correction factor = Insertion loss + Cable loss
 6. Emission Level = Correction Factor + Reading Value.

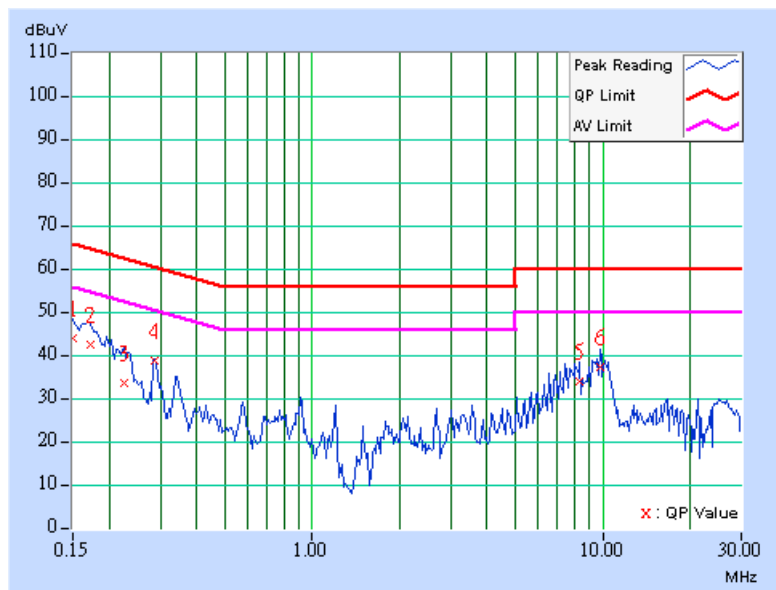



EUT	Wireless 802.11g MiniPCI Card	MODEL	WM1270
CHANNEL	11	6dB BANDWIDTH	9kHz
INPUT POWER (SYSTEM)	120Vac, 60Hz	PHASE	Line (L)
ENVIRONMENTAL CONDITIONS	20deg. C, 75%RH, 991hPa	TESTED BY: Jamison Chan	

No	Freq. [MHz]	Corr. Factor (dB)	Reading Value [dB (uV)]		Emission Level [dB (uV)]		Limit [dB (uV)]		Margin (dB)	
			Q.P.	AV.	Q.P.	AV.	Q.P.	AV.	Q.P.	AV.
			1	0.150	0.10	43.23	-	43.33	-	66.00
2	0.173	0.10	40.69	-	40.79	-	64.79	54.79	-24.00	-
3	0.220	0.10	36.10	-	36.20	-	62.81	52.81	-26.61	-
4	0.287	0.10	37.60	-	37.70	-	60.62	50.62	-22.92	-
5	8.020	0.50	35.37	-	35.87	-	60.00	50.00	-24.13	-
6	9.539	0.58	36.52	-	37.10	-	60.00	50.00	-22.90	-

- REMARKS:**
1. Q.P. and AV. are abbreviations of quasi-peak and average individually.
 2. "-": The Quasi-peak reading value also meets average limit and measurement with the average detector is unnecessary.
 3. The emission levels of other frequencies were very low against the limit.
 4. Margin value = Emission level - Limit value
 5. Correction factor = Insertion loss + Cable loss
 6. Emission Level = Correction Factor + Reading Value.

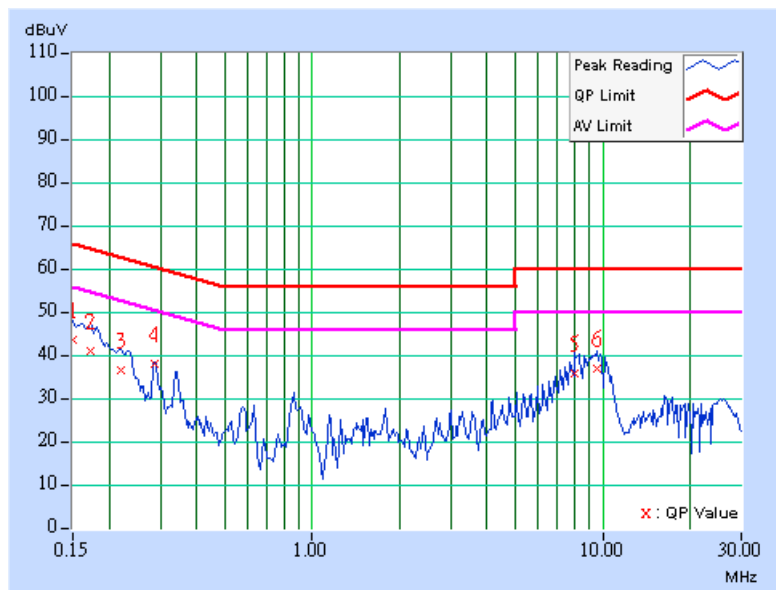



EUT	Wireless 802.11g MiniPCI Card	MODEL	WM1270
CHANNEL	11	6dB BANDWIDTH	9kHz
INPUT POWER (SYSTEM)	120Vac, 60Hz	PHASE	Neutral (N)
ENVIRONMENTAL CONDITIONS	20deg. C, 75%RH, 991hPa	TESTED BY: Jamison Chan	

No	Freq. [MHz]	Corr. Factor (dB)	Reading Value [dB (uV)]		Emission Level [dB (uV)]		Limit [dB (uV)]		Margin (dB)	
			Q.P.	AV.	Q.P.	AV.	Q.P.	AV.	Q.P.	AV.
			1	0.158	0.10	43.22	-	43.32	-	65.58
2	0.177	0.10	43.42	-	43.52	-	64.61	54.61	-21.09	-
3	0.287	0.10	38.25	-	38.35	-	60.62	50.62	-22.27	-
4	0.923	0.19	27.21	-	27.40	-	56.00	46.00	-28.60	-
5	8.031	0.43	35.08	-	35.51	-	60.00	50.00	-24.49	-
6	9.570	0.49	35.12	-	35.61	-	60.00	50.00	-24.39	-

- REMARKS:**
1. Q.P. and AV. are abbreviations of quasi-peak and average individually.
 2. "-": The Quasi-peak reading value also meets average limit and measurement with the average detector is unnecessary.
 3. The emission levels of other frequencies were very low against the limit.
 4. Margin value = Emission level - Limit value
 5. Correction factor = Insertion loss + Cable loss
 6. Emission Level = Correction Factor + Reading Value.

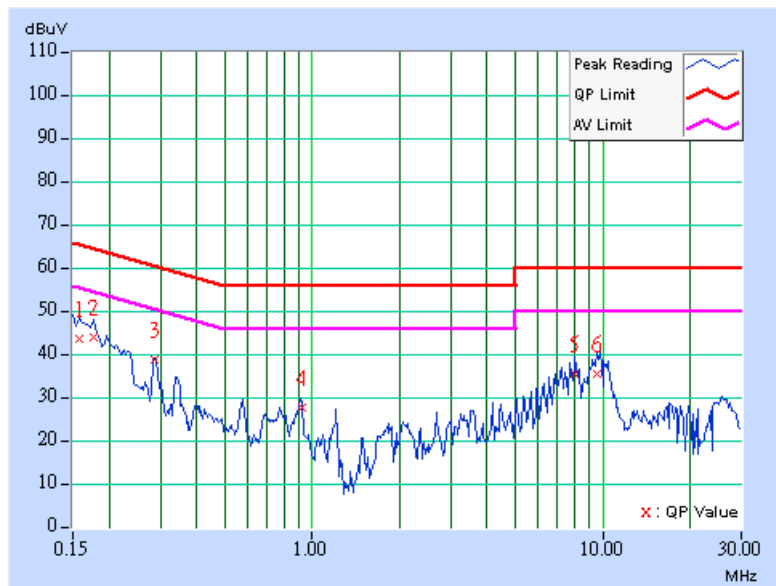



4.2 RADIATED EMISSION MEASUREMENT

4.2.1 LIMITS OF RADIATED EMISSION MEASUREMENT

Emissions radiated outside of the specified bands, shall be according to the general radiated limits in 15.209 as following:

Frequencies (MHz)	Field strength (microvolts/meter)	Measurement distance (meters)
0.009-0.490	2400/F(kHz)	300
0.490-1.705	24000/F(kHz)	30
1.705-30.0	30	30
30-88	100	3
88-216	150	3
216-960	200	3
Above 960	500	3

NOTE:

1. The lower limit shall apply at the transition frequencies.
2. Emission level (dBuV/m) = 20 log Emission level (uV/m).
3. As shown in 15.35(b), for frequencies above 1000MHz, the field strength limits are based on average detector, however, the peak field strength of any emission shall not exceed the maximum permitted average limits, specified above by more than 20dB under any condition of modulation.



4.2.2 TEST INSTRUMENTS

DESCRIPTION & MANUFACTURER	MODEL NO.	SERIAL NO.	CALIBRATED UNTIL
*HP Spectrum Analyzer	8593E	3911A07465	Jul. 07, 2004
*HP Preamplifier	8447D	2944A10386	Aug. 12, 2004
* HP Preamplifier	8449B	3008A01292	Aug. 11, 2004
SCHAFFNER Tunable Dipole Antenna	VHBA 9123	459	Jun. 26, 2004
SCHWARZBECK Tunable Dipole Antenna	UHA 9105	977	
*SCHAFFNER TEST RECEIVER	SCR 3501	409	Nov. 06, 2004
* SCHAFFNER BILOG Antenna	CBL6111C	2727	Jul. 15, 2004
* SCHWARZBECK Horn Antenna	BBHA9120-D1	D130	Jun. 30, 2004
* ADT. Turn Table	TT100	0201	NA
* ADT. Tower	AT100	0201	NA
* Software	ADT_Radiated_V5.14	NA	NA
* ANRITSU RF Switches	MP59B	6100237246	Oct. 17, 2004
* TIMES RF cable	LMR-600	CABLE-ST10-01	Oct. 17, 2004

- NOTE:**
1. The calibration interval of the above test instruments is 12 months. And the calibrations are traceable to NML/ROC and NIST/USA.
 2. "*" = These equipment are used for the final measurement.
 3. The horn antenna and HP preamplifier (model: 8449B) are used only for the measurement of emission frequency above 1GHz if tested.
 4. The test was performed in ADT Open Site No. 10.
 5. The VCCI Site Registration No. is R-1625.



4.2.3 TEST PROCEDURES

- a. The EUT was placed on the top of a rotating table 0.8 meters above the ground at a 10 meter open area test site. The table was rotated 360 degrees to determine the position of the highest radiation.
- b. The EUT was set 3 meters away from the interference-receiving antenna, which was mounted on the top of a variable-height antenna tower.
- c. The antenna is a broadband antenna, and its height is varied from one meter to four meters above the ground to determine the maximum value of the field strength. Both horizontal and vertical polarizations of the antenna are set to make the measurement.
- d. For each suspected emission, the EUT was arranged to its worst case and then the antenna was tuned to heights from 1 meter to 4 meters and the rotatable table was turned from 0 degrees to 360 degrees to find the maximum reading.
- e. The test-receiver system was set to Peak Detect Function and Specified Bandwidth with Maximum Hold Mode.
- f. If the emission level of the EUT in peak mode was 10 dB lower than the limit specified, then testing could be stopped and the peak values of the EUT would be reported. Otherwise the emissions that did not have 10 dB margin would be re-tested one by one using peak, quasi-peak or average method as specified and then reported in a data sheet.

NOTE:

1. The resolution bandwidth and video bandwidth of test receiver/spectrum analyzer is 120kHz for Peak detection (PK) and Quasi-peak detection (QP) at frequency below 1GHz.
2. The resolution bandwidth and video bandwidth of test receiver/spectrum analyzer is 1 MHz for Peak detection at frequency above 1GHz.
3. The resolution bandwidth of test receiver/spectrum analyzer is 1 MHz and the video bandwidth is 10 Hz for Average detection (AV) at frequency above 1GHz.

4.2.4 DEVIATION FROM TEST STANDARD

No deviation

4.2.5 TEST SETUP

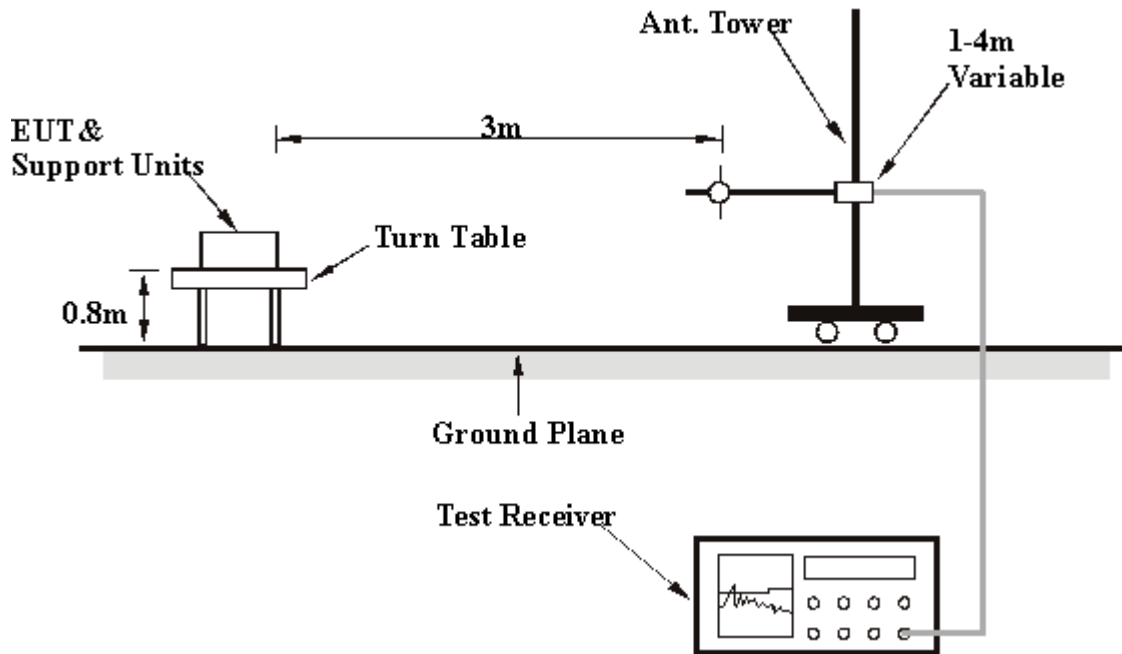

For the actual test configuration, please refer to the related item – Photographs of the Test Configuration.

4.2.6 EUT OPERATING CONDITIONS

Same as 4.1.6



4.2.7. TEST RESULTS

EUT	Wireless 802.11g MiniPCI Card	MODEL	WM1270
CHANNEL	11	FREQUENCY RANGE	Below 1000MHz
INPUT POWER (SYSTEM)	120Vac, 60Hz	DETECTOR FUNCTION	Quasi-Peak
ENVIRONMENTAL CONDITIONS	23deg. C, 80%RH, 991hPa	TESTED BY	Jun Wu

ANTENNA POLARITY & TEST DISTANCE: HORIZONTAL AT 3 M								
No.	Freq. (MHz)	Emission Level (dBuV/m)	Limit (dBuV/m)	Margin (dB)	Antenna Height (m)	Table Angle (Degree)	Raw Value (dBuV)	Correction Factor (dB/m)
1	66.53	35.35 QP	40.00	-4.65	2.20 H	116	29.25	6.10
2	132.50	39.18 QP	43.50	-4.32	2.45 H	40	26.69	12.49
3	165.80	33.65 QP	43.50	-9.85	2.45 H	70	23.09	10.56
4	199.61	41.54 QP	43.50	-1.96	2.28 H	91	31.08	10.46
5	231.93	38.70 QP	46.00	-7.30	1.98 H	326	26.03	12.67
6	331.00	33.01 QP	46.00	-12.99	1.76 H	180	16.11	16.90
7	399.00	34.27 QP	46.00	-11.73	1.58 H	276	14.89	19.38
8	500.00	33.95 QP	46.00	-12.05	1.00 H	54	12.05	21.90
9	533.00	33.23 QP	46.00	-12.77	1.00 H	0	10.39	22.84
10	566.00	34.34 QP	46.00	-11.66	1.00 H	49	10.65	23.69
11	797.50	33.43 QP	46.00	-12.57	1.00 H	325	6.23	27.20

- REMARKS:**
1. Emission level(dBuV/m)=Raw Value(dBuV) + Correction Factor(dB)
 2. Correction Factor(dB/m) = Antenna Factor (dB/m) + Cable Factor (dB)
 3. The other emission levels were very low against the limit.
 4. Margin value = Emission level – Limit value.



EUT	Wireless 802.11g MiniPCI Card	MODEL	WM1270
CHANNEL	11	FREQUENCY RANGE	Below 1000MHz
INPUT POWER (SYSTEM)	120Vac, 60Hz	DETECTOR FUNCTION	Quasi-Peak
ENVIRONMENTAL CONDITIONS	23deg. C, 80%RH, 991hPa	TESTED BY	Jun Wu

ANTENNA POLARITY & TEST DISTANCE: VERTICAL AT 3 M

No.	Freq. (MHz)	Emission Level (dBuV/m)	Limit (dBuV/m)	Margin (dB)	Antenna Height (m)	Table Angle (Degree)	Raw Value (dBuV)	Correction Factor (dB/m)
1	66.51	35.16 QP	40.00	-4.84	1.00 V	272	29.06	6.10
2	166.48	33.04 QP	43.50	-10.46	1.00 V	51	22.50	10.54
3	199.60	41.10 QP	43.50	-2.40	1.00 V	221	30.64	10.46
4	231.75	36.65 QP	46.00	-9.35	1.00 V	9	23.99	12.66
5	331.00	32.87 QP	46.00	-13.13	1.63 V	224	15.97	16.90
6	454.00	32.11 QP	46.00	-13.89	1.90 V	78	11.62	20.49
7	530.00	34.22 QP	46.00	-11.78	1.43 V	250	11.46	22.76
8	566.00	36.93 QP	46.00	-9.07	1.15 V	309	13.24	23.69
9	795.30	33.24 QP	46.00	-12.76	1.00 V	0	6.04	27.21

- REMARKS:**
1. Emission level(dBuV/m)=Raw Value(dBuV) + Correction Factor(dB)
 2. Correction Factor(dB/m) = Antenna Factor (dB/m) + Cable Factor (dB)
 3. The other emission levels were very low against the limit.
 4. Margin value = Emission level – Limit value.



EUT	Wireless 802.11g MiniPCI Card	MODEL	WM1270
CHANNEL	1	FREQUENCY RANGE	1 ~ 25GHz
TEST MODE	CCK	INPUT POWER (SYSTEM)	120Vac, 60Hz
ENVIRONMENTAL CONDITIONS	23deg. C, 80%RH, 991hPa	DETECTOR FUNCTION	Peak (PK) Average (AV)
TESTED BY: Jun Wu			

ANTENNA POLARITY & TEST DISTANCE: HORIZONTAL AT 3 M								
No.	Freq. (MHz)	Emission Level (dBuV/m)	Limit (dBuV/m)	Margin (dB)	Antenna Height (m)	Table Angle (Degree)	Raw Value (dBuV)	Correction Factor (dB/m)
1	2390.00	43.93 PK	74.00	-30.07	1.16 H	4	13.63	30.30
1	2390.00	35.87 AV	54.00	-18.13	1.16 H	4	5.57	30.30
2	*2412.00	101.47 PK			1.16 H	4	71.23	30.24
2	*2412.00	93.41 AV			1.16 H	4	63.17	30.24
3	3215.00	44.33 PK	74.00	-29.67	1.16 H	301	10.70	33.63
4	4824.00	51.15 PK	74.00	-22.85	1.37 H	21	14.62	36.53
4	4824.00	40.21 AV	54.00	-13.79	1.37 H	21	3.68	36.53

ANTENNA POLARITY & TEST DISTANCE: VERTICAL AT 3 M								
No.	Freq. (MHz)	Emission Level (DbuV/m)	Limit (dBuV/m)	Margin (dB)	Antenna Height (m)	Table Angle (Degree)	Raw Value (dBuV)	Correction Factor (dB/m)
1	2390.00	51.87 PK	74.00	-22.13	1.23 V	11	21.57	30.30
1	2390.00	43.67 AV	54.00	-10.33	1.23 V	11	13.37	30.30
2	*2412.00	109.41 PK			1.23 V	11	79.17	30.24
2	*2412.00	101.24 AV			1.23 V	11	71.00	30.24
3	3215.00	47.00 PK	74.00	-27.00	1.11 V	0	13.37	33.63
4	4824.00	64.50 PK	74.00	-9.50	1.23 V	11	27.97	36.53
4	4824.00	52.83 AV	54.00	-1.17	1.23 V	11	16.30	36.53

- REMARKS:**
1. Emission level (dBuV/m)=Raw Value (dBuV) + Correction Factor (dB)
 2. Correction Factor (dB/m) = Antenna Factor (dB/m) + Cable Factor (dB)
 3. The other emission levels were very low against the limit.
 4. Margin value = Emission level – Limit value.
 5. “ * “: Fundamental frequency.



EUT	Wireless 802.11g MiniPCI Card	MODEL	WM1270
CHANNEL	6	FREQUENCY RANGE	1 ~ 25GHz
TEST MODE	CCK	INPUT POWER (SYSTEM)	120Vac, 60Hz
ENVIRONMENTAL CONDITIONS	23deg. C, 80%RH, 991hPa	DETECTOR FUNCTION	Peak (PK) Average (AV)
TESTED BY: Jun Wu			

ANTENNA POLARITY & TEST DISTANCE: HORIZONTAL AT 3 M

No.	Freq. (MHz)	Emission Level (dBuV/m)	Limit (dBuV/m)	Margin (dB)	Antenna Height (m)	Table Angle (Degree)	Raw Value (dBuV)	Correction Factor (dB/m)
1	*2437.00	102.81 PK	74.00		1.16 H	4	72.50	30.31
1	*2437.00	94.81 AV	54.00		1.16 H	4	64.50	30.31
2	3249.00	42.12 PK	74.00	-31.88	1.21 H	320	8.52	33.60
3	4874.00	50.29 PK	74.00	-23.71	1.33 H	2	13.60	36.69
3	4874.00	45.19 AV	54.00	-8.81	1.33 H	2	8.50	36.69

ANTENNA POLARITY & TEST DISTANCE: VERTICAL AT 3 M

No.	Freq. (MHz)	Emission Level (dBuV/m)	Limit (dBuV/m)	Margin (dB)	Antenna Height (m)	Table Angle (Degree)	Raw Value (dBuV)	Correction Factor (dB/m)
1	*2437.00	109.81 PK			1.22 V	360	79.50	30.31
1	*2437.00	101.81 AV			1.22 V	360	71.50	30.31
2	3249.00	47.63 PK	74.00	-26.37	1.14 V	339	14.03	33.60
2	3249.00	43.13 AV	54.00	-10.84	1.14 V	339	9.53	33.60
3	4874.00	65.49 PK	74.00	-8.51	1.33 V	342	28.80	36.69
3	4874.00	52.66 AV	54.00	-1.34	1.33 V	342	15.97	36.69

- REMARKS:**
1. Emission level (dBuV/m)=Raw Value (dBuV) + Correction Factor (dB)
 2. Correction Factor (dB/m) = Antenna Factor (dB/m) + Cable Factor (dB)
 3. The other emission levels were very low against the limit.
 4. Margin value = Emission level – Limit value.
 5. “ * “: Fundamental frequency.



EUT	Wireless 802.11g MiniPCI Card	MODEL	WM1270
CHANNEL	11	FREQUENCY RANGE	1 ~ 25GHz
TEST MODE	CCK	INPUT POWER (SYSTEM)	120Vac, 60Hz
ENVIRONMENTAL CONDITIONS	23deg. C, 80%RH, 991hPa	DETECTOR FUNCTION	Peak (PK) Average (AV)
TESTED BY: Jun Wu			

ANTENNA POLARITY & TEST DISTANCE: HORIZONTAL AT 3 M								
No.	Freq. (MHz)	Emission Level (dBuV/m)	Limit (dBuV/m)	Margin (dB)	Antenna Height (m)	Table Angle (Degree)	Raw Value (dBuV)	Correction Factor (dB/m)
1	*2462.00	102.87 PK			1.22 H	0	72.50	30.37
1	*2462.00	95.04 AV			1.22 H	0	64.67	30.37
2	2483.50	45.70 PK	74.00	-28.30	1.22 H	0	15.27	30.43
2	2483.50	37.87 AV	54.00	-16.13	1.22 H	0	7.44	30.43
3	3277.00	43.03 PK	74.00	-30.97	1.15 H	214	9.45	33.58
4	4924.00	47.15 PK	54.00	-26.85	1.15 H	70	10.30	36.85

ANTENNA POLARITY & TEST DISTANCE: VERTICAL AT 3 M								
No.	Freq. (MHz)	Emission Level (dBuV/m)	Limit (dBuV/m)	Margin (dB)	Antenna Height (m)	Table Angle (Degree)	Raw Value (dBuV)	Correction Factor (dB/m)
1	*2462.00	110.70 PK			1.20 V	360	80.33	30.37
1	*2642.00	103.37 AV			1.20 V	360	73.00	30.37
2	2483.50	53.53 PK	74.00	-20.47	1.20 V	360	23.10	30.43
2	2483.50	46.20 AV	54.00	-7.80	1.20 V	360	15.77	30.43
3	3277.00	48.08 PK	74.00	-25.92	1.22 V	87	14.50	33.58
4	4924.00	65.48 PK	74.00	-8.52	1.32 V	259	28.63	36.85
4	4924.00	52.98 AV	54.00	-1.02	1.32 V	259	16.13	36.85

- REMARKS:**
1. Emission level (dBuV/m)=Raw Value (dBuV) + Correction Factor (dB)
 2. Correction Factor (dB/m) = Antenna Factor (dB/m) + Cable Factor (dB)
 3. The other emission levels were very low against the limit.
 4. Margin value = Emission level – Limit value.
 5. “ * “: Fundamental frequency.



EUT	Wireless 802.11g MiniPCI Card	MODEL	WM1270
CHANNEL	1	FREQUENCY RANGE	1 ~ 25GHz
TEST MODE	OFDM	INPUT POWER (SYSTEM)	120Vac, 60Hz
ENVIRONMENTAL CONDITIONS	23deg. C, 80%RH, 991hPa	DETECTOR FUNCTION	Peak (PK) Average (AV)
TESTED BY: Jun Wu			

ANTENNA POLARITY & TEST DISTANCE: HORIZONTAL AT 3 M								
No.	Freq. (MHz)	Emission Level (dBuV/m)	Limit (dBuV/m)	Margin (dB)	Antenna Height (m)	Table Angle (Degree)	Raw Value (dBuV)	Correction Factor (dB/m)
1	2390.00	52.07 PK	74.00	-21.93	1.00 H	310	21.77	30.30
1	2390.00	42.24 AV	54.00	-11.76	1.00 H	310	11.94	30.30
2	*2412.00	102.57 PK			1.00 H	310	72.33	30.24
2	*2412.00	92.74 AV			1.00 H	310	62.50	30.24
3	3217.00	45.45 PK	74.00	-28.55	1.11 H	214	11.82	33.63
4	4824.00	54.00 PK	74.00	-20.00	1.40 H	307	17.47	36.53
4	4824.00	41.13 AV	54.00	-12.87	1.40 H	307	4.60	36.53

ANTENNA POLARITY & TEST DISTANCE: VERTICAL AT 3 M								
No.	Freq. (MHz)	Emission Level (dBuV/m)	Limit (dBuV/m)	Margin (dB)	Antenna Height (m)	Table Angle (Degree)	Raw Value (dBuV)	Correction Factor (dB/m)
1	2390.00	58.24 PK	74.00	-15.76	1.00 V	185	27.94	30.30
1	2390.00	48.07 AV	54.00	-5.93	1.00 V	185	17.77	30.30
2	*2412.00	108.74 PK			1.00 V	185	78.50	30.24
2	*2412.00	98.57 AV			1.00 V	185	68.33	30.24
3	3217.00	47.83 PK		-26.17	1.26 V	360	14.20	33.63
4	4824.00	64.20 PK	74.00	-9.80	1.11 V	327	27.67	36.53
4	4824.00	49.83 AV	54.00	-4.17	1.11 V	327	13.30	36.53

- REMARKS:**
1. Emission level (dBuV/m)=Raw Value (dBuV) + Correction Factor (dB)
 2. Correction Factor (dB/m) = Antenna Factor (dB/m) + Cable Factor (dB)
 3. The other emission levels were very low against the limit.
 4. Margin value = Emission level – Limit value.
 5. “ * “: Fundamental frequency.



EUT	Wireless 802.11g MiniPCI Card	MODEL	WM1270
CHANNEL	6	FREQUENCY RANGE	1 ~ 25GHz
TEST MODE	OFDM	INPUT POWER (SYSTEM)	120Vac, 60Hz
ENVIRONMENTAL CONDITIONS	23deg. C, 80%RH, 991hPa	DETECTOR FUNCTION	Peak (PK) Average (AV)
TESTED BY: Jun Wu			

ANTENNA POLARITY & TEST DISTANCE: HORIZONTAL AT 3 M

No.	Freq. (MHz)	Emission Level (dBuV/m)	Limit (dBuV/m)	Margin (dB)	Antenna Height (m)	Table Angle (Degree)	Raw Value (dBuV)	Correction Factor (dB/m)
1	*2437.00	102.81 PK			1.00 H	297	72.50	30.31
1	*2437.00	92.14 AV			1.00 H	297	61.83	30.31
2	3249.00	45.12 PK	74.00	-28.88	1.08 H	241	11.52	33.60
3	4874.00	51.31 PK	74.00	-22.69	1.27 H	128	14.62	36.69
3	4874.00	40.09 AV	54.00	-13.91	1.27 H	128	3.40	36.69

ANTENNA POLARITY & TEST DISTANCE: VERTICAL AT 3 M

No.	Freq. (MHz)	Emission Level (dBuV/m)	Limit (dBuV/m)	Margin (dB)	Antenna Height (m)	Table Angle (Degree)	Raw Value (dBuV)	Correction Factor (dB/m)
1	*2437.00	108.64 PK			1.20 V	360	78.33	30.31
1	*2437.00	97.81 AV			1.20 V	360	67.50	30.31
2	3249.00	48.10 PK	74.00	-25.90	1.00 V	185	14.50	33.60
3	4874.00	63.82 PK	74.00	-10.18	1.10 V	306	27.13	36.69
3	4874.00	49.16 AV	54.00	-4.84	1.10 V	306	12.47	36.69

- REMARKS:**
1. Emission level (dBuV/m)=Raw Value (dBuV) + Correction Factor (dB)
 2. Correction Factor (dB/m) = Antenna Factor (dB/m) + Cable Factor (dB)
 3. The other emission levels were very low against the limit.
 4. Margin value = Emission level – Limit value.
 5. “ * ”: Fundamental frequency.



EUT	Wireless 802.11g MiniPCI Card	MODEL	WM1270
CHANNEL	11	FREQUENCY RANGE	1 ~ 25GHz
TEST MODE	OFDM	INPUT POWER (SYSTEM)	120Vac, 60Hz
ENVIRONMENTAL CONDITIONS	23deg. C, 80%RH, 991hPa	DETECTOR FUNCTION	Peak (PK) Average (AV)
TESTED BY: Jun Wu			

ANTENNA POLARITY & TEST DISTANCE: HORIZONTAL AT 3 M

No.	Freq. (MHz)	Emission Level (dBuV/m)	Limit (dBuV/m)	Margin (dB)	Antenna Height (m)	Table Angle (Degree)	Raw Value (dBuV)	Correction Factor (dB/m)
1	*2462.00	103.20 PK			1.25 H	312	72.83	30.37
1	*2462.00	92.70 AV			1.25 H	312	62.33	30.37
2	2483.50	54.05 PK	74.00	-19.95	1.25 H	312	23.62	30.43
2	2483.50	43.55 AV	54.00	-10.45	1.25 H	312	13.12	30.43
3	3282.00	45.94 PK	74.00	-28.06	1.45 H	214	12.37	33.57
4	4924.00	53.48 PK	74.00	-20.52	1.44 H	256	16.63	36.85
4	4924.00	39.48 AV	54.00	-14.52	1.44 H	256	2.63	36.85

ANTENNA POLARITY & TEST DISTANCE: VERTICAL AT 3 M

No.	Freq. (MHz)	Emission Level (dBuV/m)	Limit (dBuV/m)	Margin (dB)	Antenna Height (m)	Table Angle (Degree)	Raw Value (dBuV)	Correction Factor (dB/m)
1	*2462.00	108.87 PK			1.20 V	356	78.50	30.37
1	*2462.00	97.87 AV			1.20 V	356	67.50	30.37
2	2483.50	59.72 PK	74.00	-14.28	1.20 V	356	29.29	30.43
2	2483.50	48.72 AV	54.00	-5.28	1.20 V	356	18.29	30.43
3	3282.00	46.97 PK	74.00	-27.03	1.00 V	6	13.40	33.57
4	4924.00	56.98 PK	74.00	-17.02	1.15 V	9	20.13	36.85
4	4924.00	42.98 AV	54.00	-11.02	1.15 V	9	6.13	36.85

- REMARKS:**
1. Emission level (dBuV/m)=Raw Value (dBuV) + Correction Factor (dB)
 2. Correction Factor (dB/m) = Antenna Factor (dB/m) + Cable Factor (dB)
 3. The other emission levels were very low against the limit.
 4. Margin value = Emission level – Limit value.
 5. “ * “: Fundamental frequency.



4.3 6dB BANDWIDTH MEASUREMENT

4.3.1 LIMITS OF 6dB BANDWIDTH MEASUREMENT

The minimum of 6dB Bandwidth Measurement is 0.5 MHz.

4.3.2 TEST INSTRUMENTS

Description & Manufacturer	Model No.	Serial No.	Calibrated Until
SPECTRUM ANALYZER	FSEK30	100049	Aug. 12, 2004

NOTE: The calibration interval of the above test instruments is 12 months and the calibrations are traceable to NML/ROC and NIST/USA.

4.3.3 TEST PROCEDURE

The transmitter output was connected to the spectrum analyzer through an attenuator. The bandwidth of the fundamental frequency was measured by spectrum analyzer with 100kHz RBW and 100kHz VBW. The 6dB bandwidth is defined as the total spectrum the power of which is higher than peak power minus 6dB.

4.3.4 DEVIATION FROM TEST STANDARD

No deviation

4.3.5 TEST SETUP

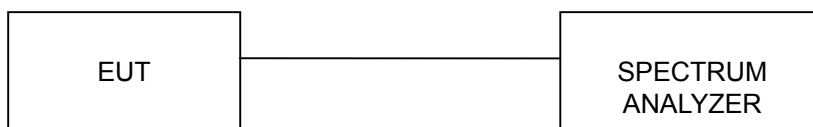

For the actual test configuration, please refer to the related Item – Photographs of the Test Configuration.

4.3.6 EUT OPERATING CONDITIONS

The software provided by client to enable the EUT under transmission condition continuously at lowest, middle and highest channel frequencies individually.



4.3.7 TEST RESULTS

EUT	Wireless 802.11g MiniPCI Card	MODEL	WM1270
INPUT POWER (SYSTEM)	120Vac, 60Hz	ENVIRONMENTAL CONDITIONS	20deg. C, 72%RH, 991hPa
TEST MODE	CCK	TESTED BY	Steven Lu

CHANNEL	CHANNEL FREQUENCY (MHz)	6dB BANDWIDTH (MHz)	MINIMUM LIMIT (MHz)	PASS/FAIL
1	2412	10.52	0.5	PASS
6	2437	9.92	0.5	PASS
11	2462	10.04	0.5	PASS



CH1

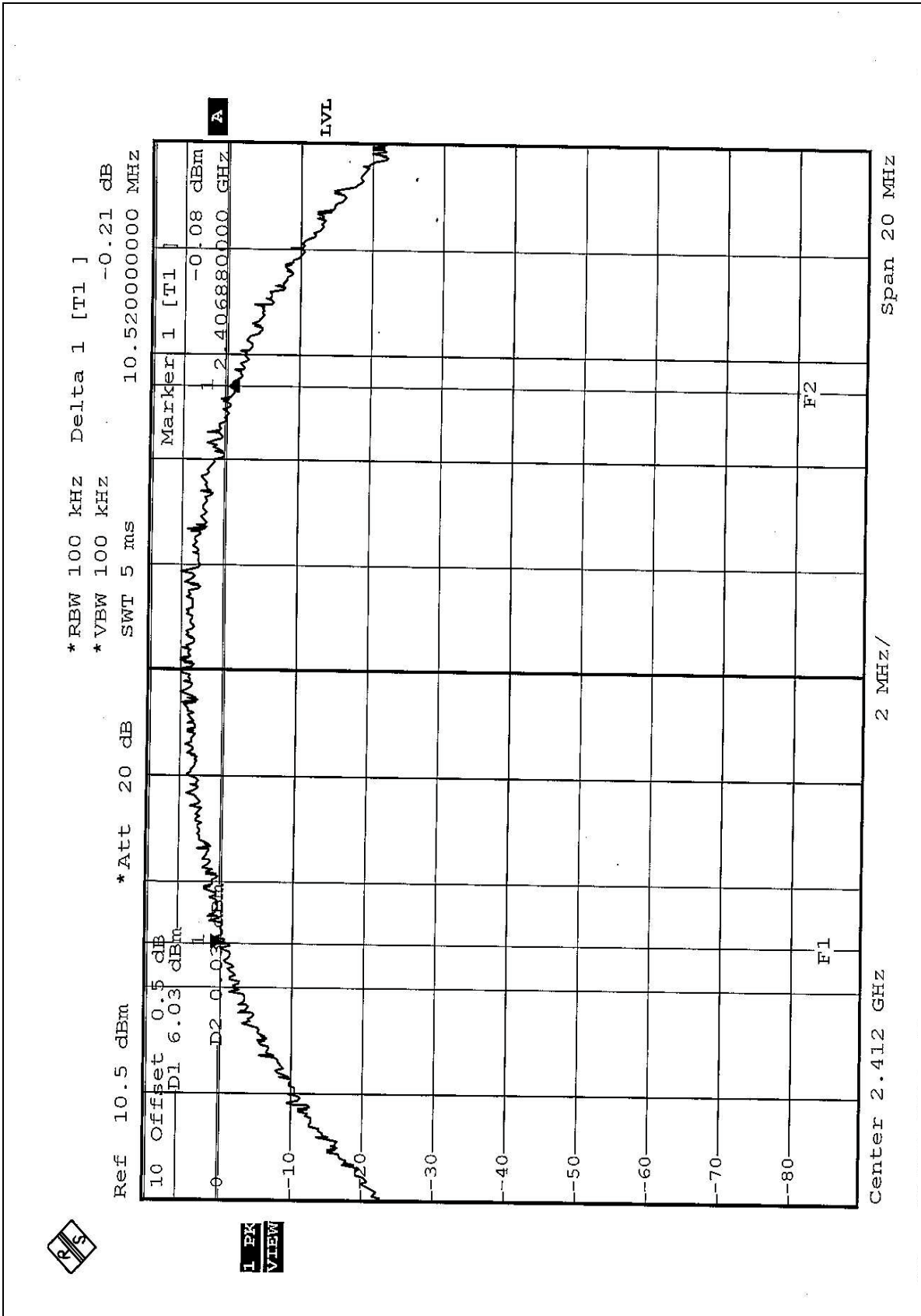



CH6

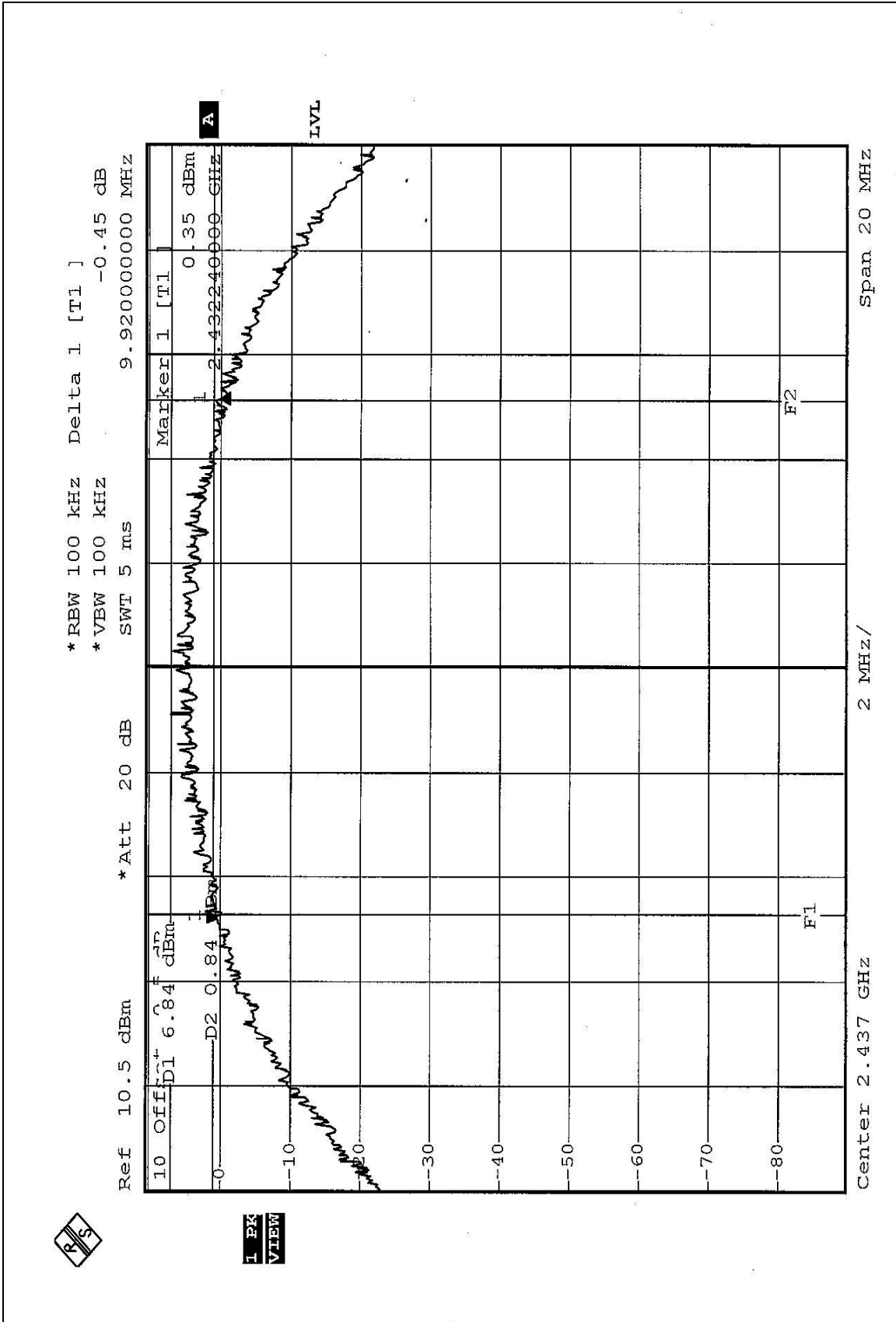



CH11

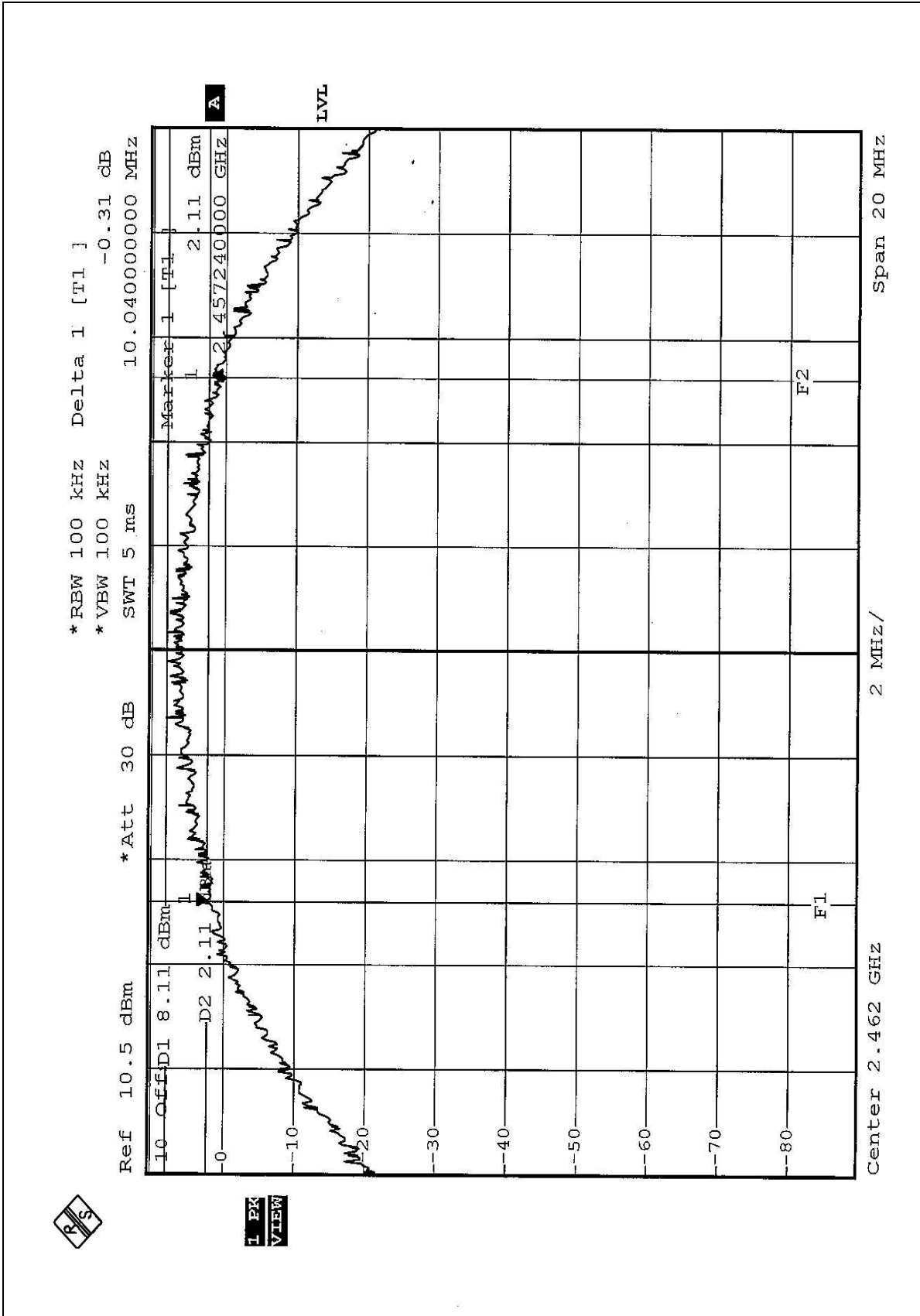

1 EX VIEW



EUT	Wireless 802.11g MiniPCI Card	MODEL	WM1270
INPUT POWER (SYSTEM)	120Vac, 60Hz	ENVIRONMENTAL CONDITIONS	20deg. C, 72%RH, 991hPa
TEST MODE	OFDM	TESTED BY	Steven Lu

CHANNEL	CHANNEL FREQUENCY (MHz)	6dB BANDWIDTH (MHz)	MINIMUM LIMIT (MHz)	PASS/FAIL
1	2412	16.56	0.5	PASS
6	2437	16.52	0.5	PASS
11	2462	16.48	0.5	PASS



CH1

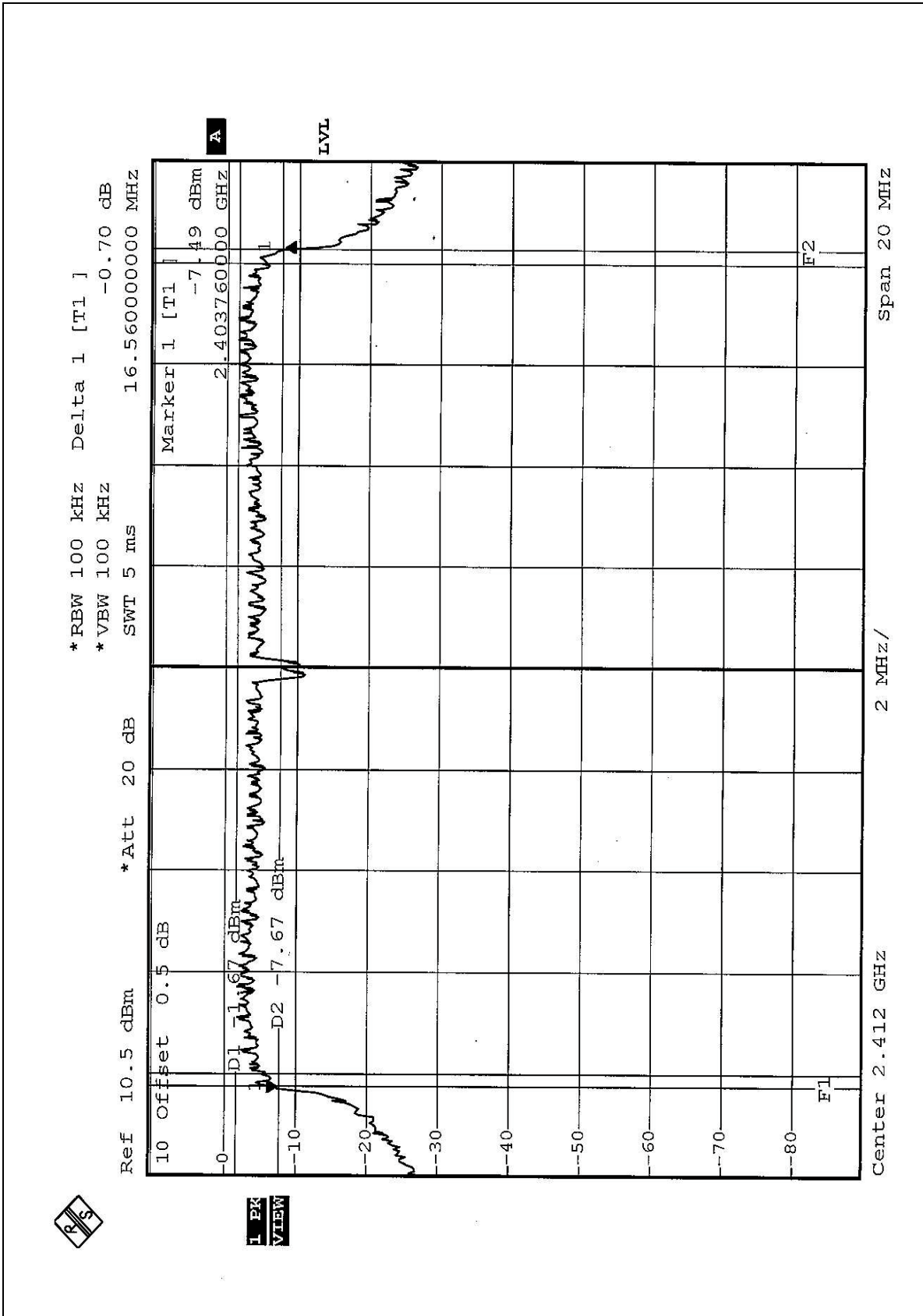

1 EK VIEW



CH6

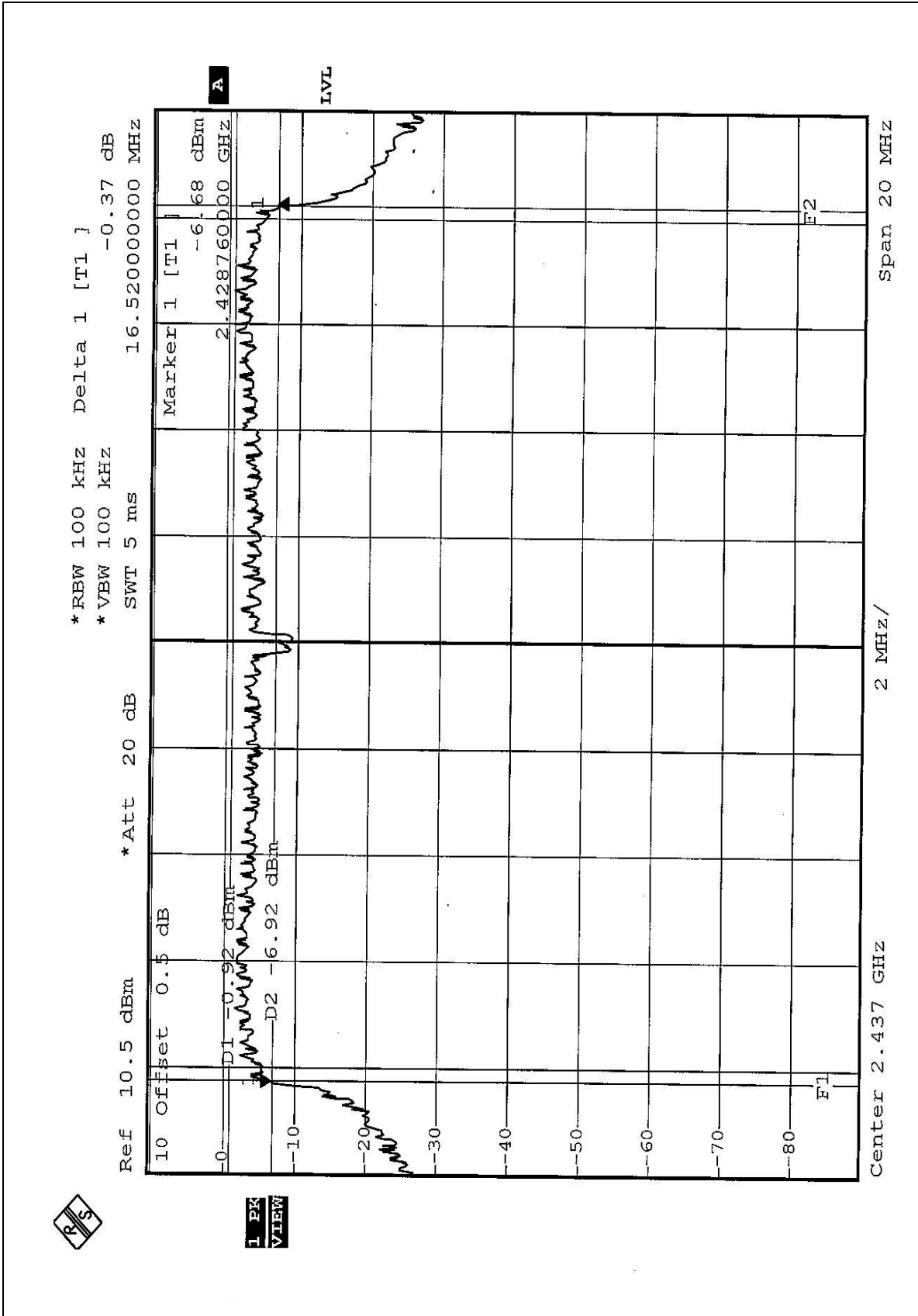



CH11

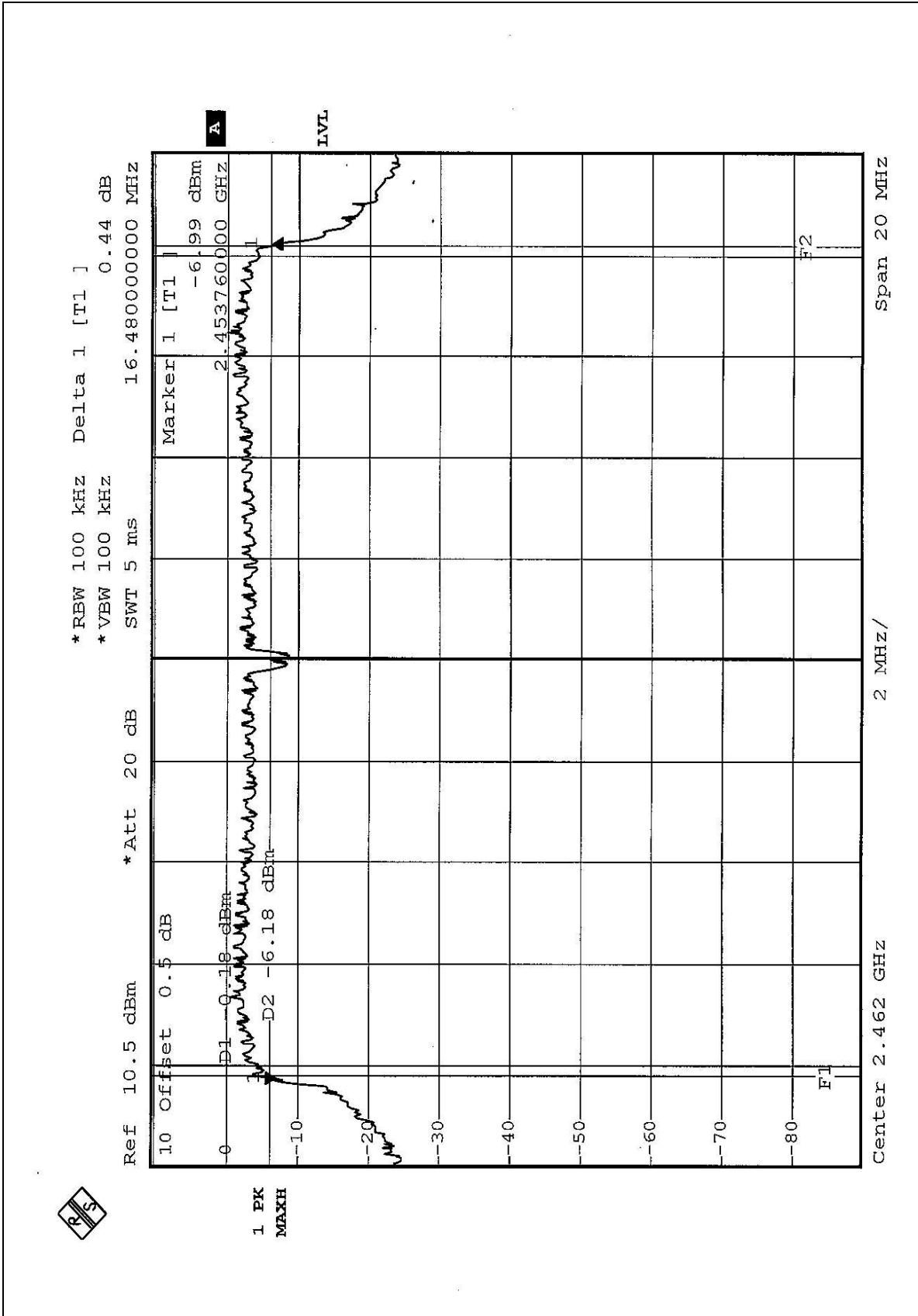



4.4 MAXIMUM PEAK OUTPUT POWER

4.4.1 LIMITS OF MAXIMUM PEAK OUTPUT POWER MEASUREMENT

The Maximum Peak Output Power Measurement is 30dBm.

4.4.2 TEST INSTRUMENTS

Description & Manufacturer	Model No.	Serial No.	Calibrated Until
R&S SPECTRUM ANALYZER	FSEK30	100049	Aug. 12, 2004
R&S SIGNAL GENERATOR	SMP04	100011	May 28, 2004
TEKTRONIX OSCILLOSCOPE	TDS 1012	C019167	Feb. 01, 2005
NARDA DETECTOR	4503A	FSCM99899	NA

NOTE:

The calibration interval of the above test instruments is 12 months and the calibrations are traceable to NML/ROC and NIST/USA..



4.4.3 TEST PROCEDURES

1. A detector was used on the output port of the EUT. An oscilloscope was used to read the response of the detector.
2. Replaced the EUT by the signal generator. The center frequency of the S.G was adjusted to the center frequency of the measured channel.
3. Adjusted the power to have the same reading on oscilloscope. Record the power level.

4.4.4 DEVIATION FROM TEST STANDARD

No deviation

4.4.5 TEST SETUP



4.4.6 EUT OPERATING CONDITIONS

Same as Item 4.3.6



4.4.7 TEST RESULTS

EUT	Wireless 802.11g MiniPCI Card	MODEL	WM1270
ENVIRONMENTAL CONDITIONS	20deg. C, 72%RH, 991hPa	INPUT POWER (SYSTEM)	120Vac, 60Hz
TEST MODE	CCK	TESTED BY	Steven Lu

CHANNEL	CHANNEL FREQUENCY (MHz)	PEAK POWER OUTPUT (dBm)	PEAK POWER LIMIT (dBm)	PASS/FAIL
1	2412	16.93	30	PASS
6	2437	17.01	30	PASS
11	2462	17.50	30	PASS

EUT	Wireless 802.11g MiniPCI Card	MODEL	WM1270
ENVIRONMENTAL CONDITIONS	20deg. C, 72%RH, 991hPa	INPUT POWER (SYSTEM)	120Vac, 60Hz
TEST MODE	OFDM	TESTED BY	Steven Lu

CHANNEL	CHANNEL FREQUENCY (MHz)	PEAK POWER OUTPUT (dBm)	PEAK POWER LIMIT (dBm)	PASS/FAIL
1	2412	17.49	30	PASS
6	2437	17.53	30	PASS
11	2462	17.31	30	PASS



4.5 POWER SPECTRAL DENSITY MEASUREMENT

4.5.1 LIMITS OF POWER SPECTRAL DENSITY MEASUREMENT

The Maximum of Power Spectral Density Measurement is 8dBm.

4.5.2 TEST INSTRUMENTS

Description & Manufacturer	Model No.	Serial No.	Calibrated Until
SPECTRUM ANALYZER	FSEK30	100049	Aug. 12, 2004

NOTE: The calibration interval of the above test instruments is 12 months and the calibrations are traceable to NML/ROC and NIST/USA.

4.5.3 TEST PROCEDURE

The transmitter output was connected to the spectrum analyzer through an attenuator, the bandwidth of the fundamental frequency was measured with the spectrum analyzer using 3kHz RBW and 30kHz VBW, set sweep time=span/3kHz. The power spectral density was measured and recorded. The sweep time is allowed to be longer than span/3KHz for a full response of the mixer in the spectrum analyzer.

4.5.4 DEVIATION FROM TEST STANDARD

No deviation

4.5.5 TEST SETUP

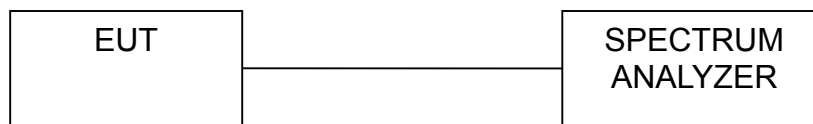

4.5.6 EUT OPERATING CONDITIONS

Same as 4.3.6



4.5.7 TEST RESULTS

EUT	Wireless 802.11g MiniPCI Card	MODEL	WM1270
INPUT POWER (SYSTEM)	120Vac, 60Hz	ENVIRONMENTAL CONDITIONS	20deg. C, 72%RH, 991hPa
TEST MODE	CCK	TESTED BY	Steven Lu

CHANNEL NUMBER	CHANNEL FREQUENCY (MHz)	RF POWER LEVEL IN 3 KHz BW (dBm)	MAXIMUM LIMIT (dBm)	PASS/FAIL
1	2412	-7.93	8	PASS
6	2437	-7.67	8	PASS
11	2462	-7.01	8	PASS



CH1

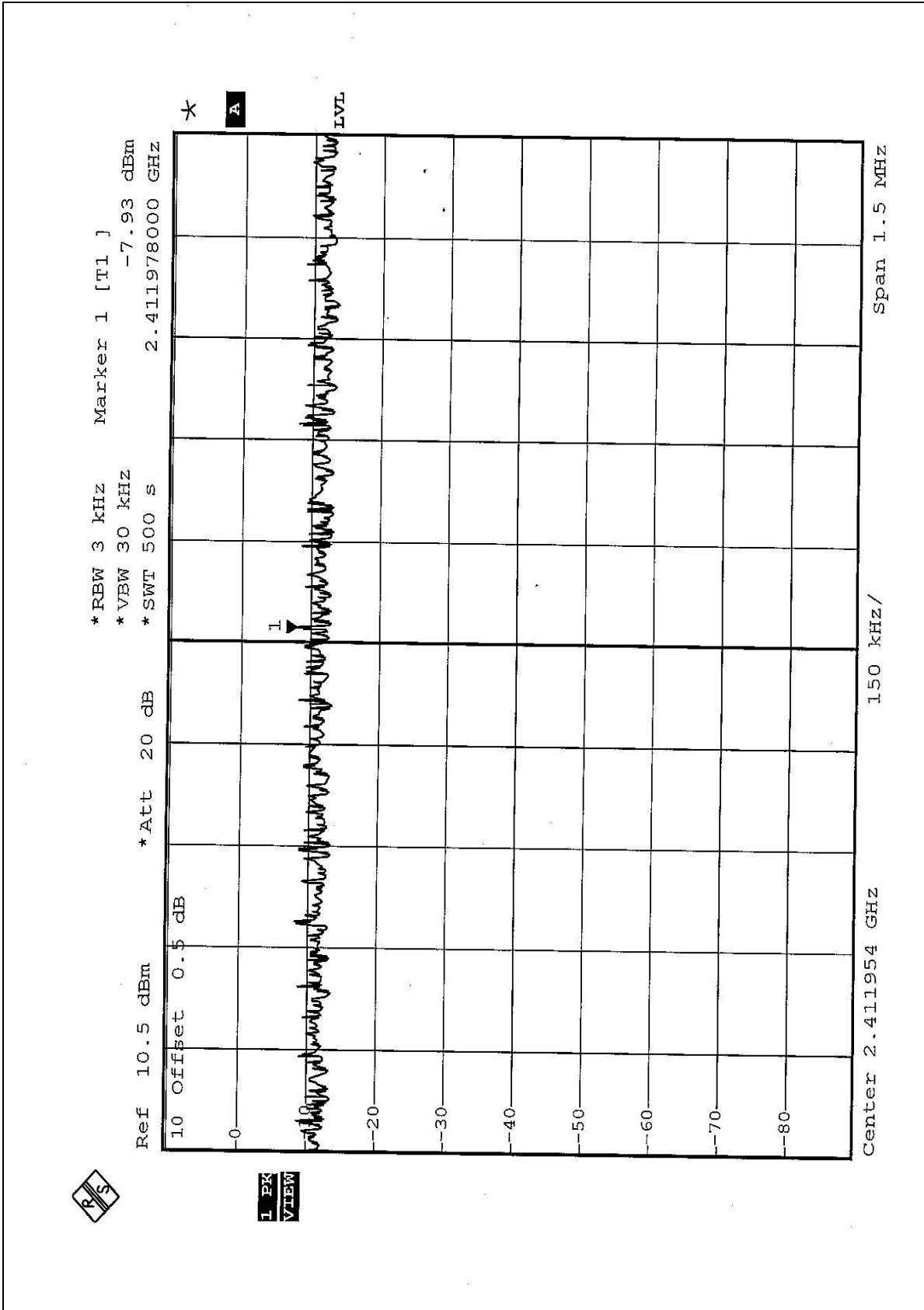



CH6

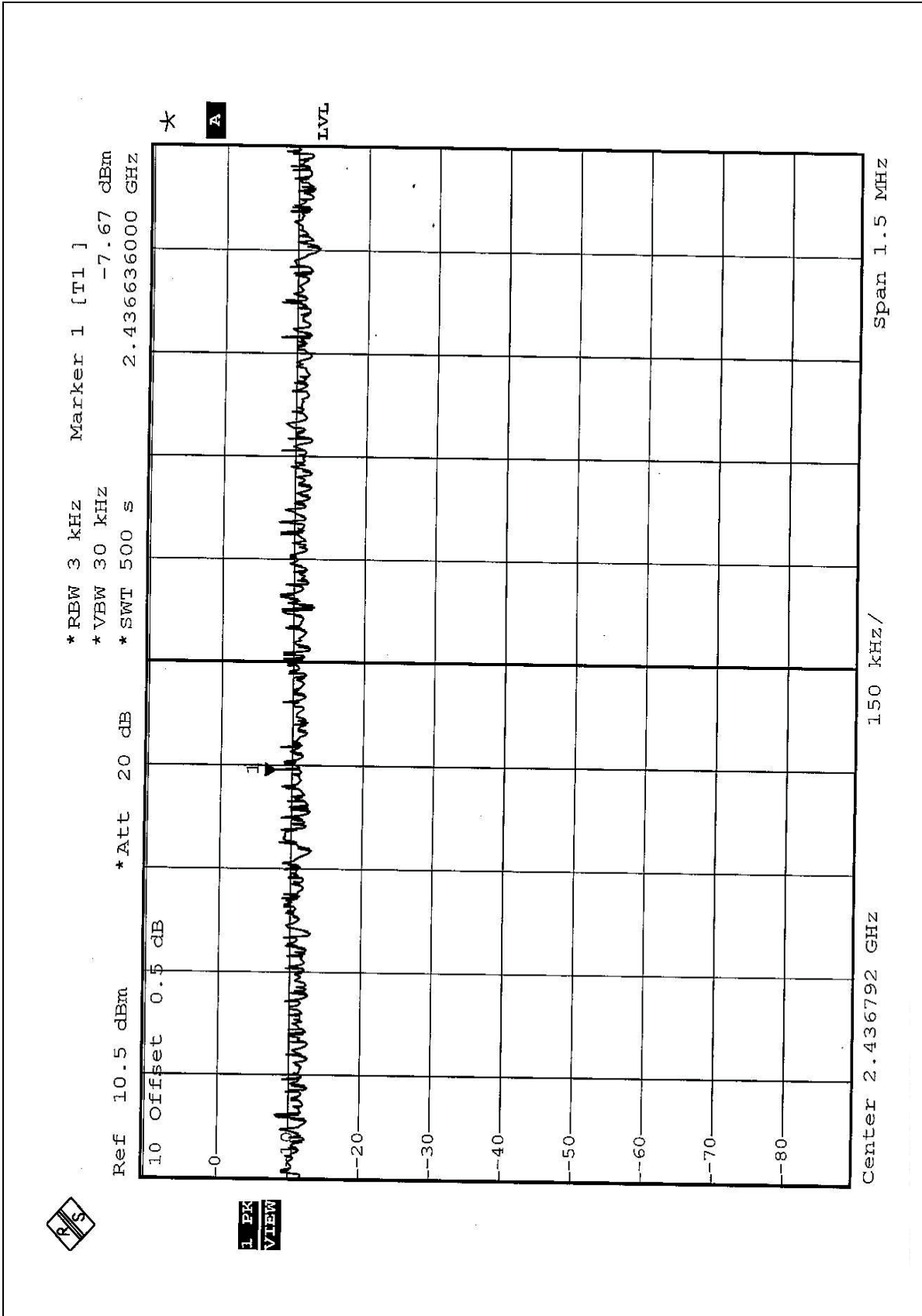



CH11

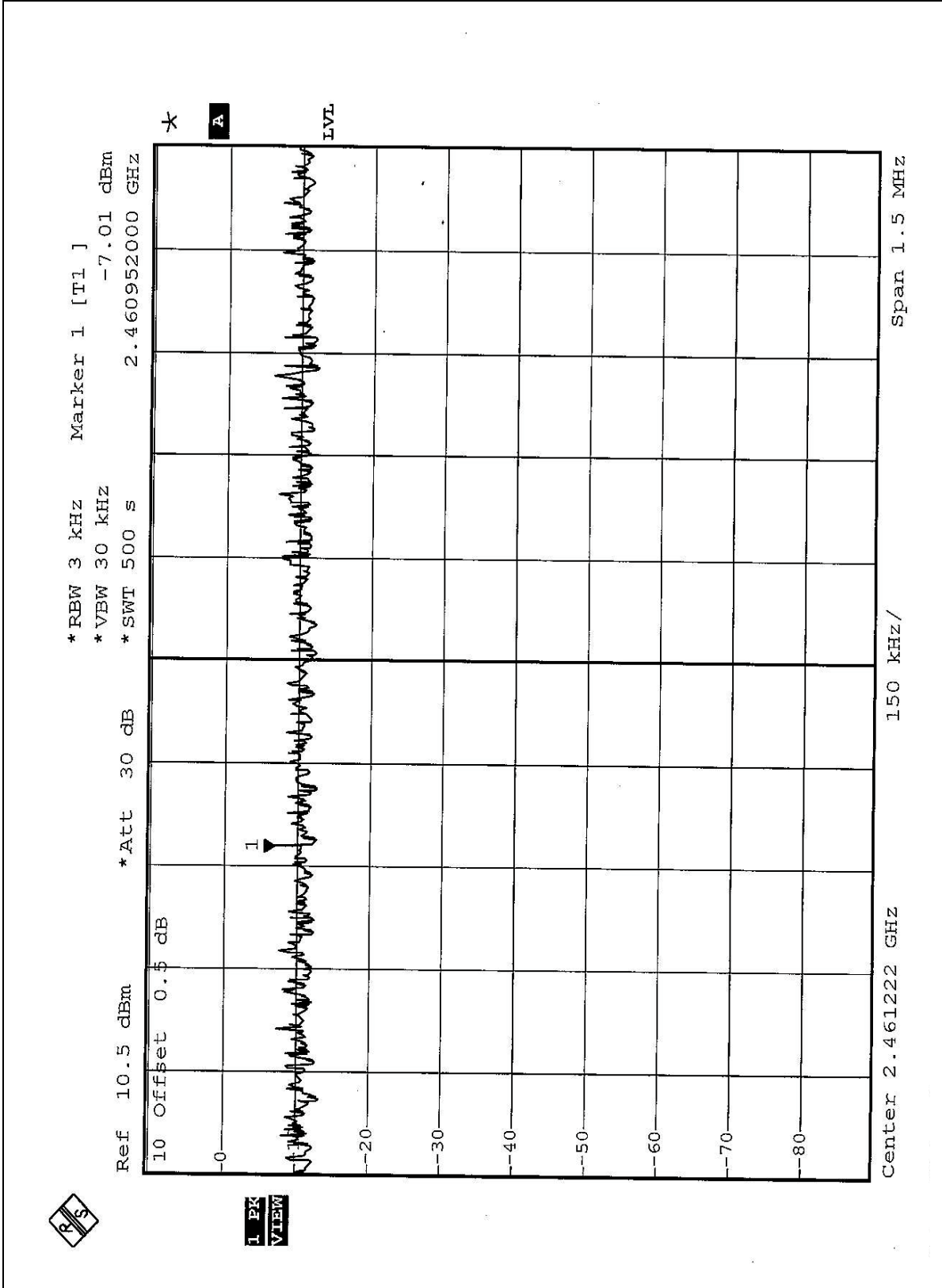



EUT	Wireless 802.11g MiniPCI Card	MODEL	WM1270
INPUT POWER (SYSTEM)	120Vac, 60Hz	ENVIRONMENTAL CONDITIONS	20deg. C, 72%RH, 991hPa
TEST MODE	OFDM	TESTED BY	Steven Lu

CHANNEL NUMBER	CHANNEL FREQUENCY (MHz)	RF POWER LEVEL IN 3 KHz BW (dBm)	MAXIMUM LIMIT (dBm)	PASS/FAIL
1	2412	-12.16	8	PASS
6	2437	-12.28	8	PASS
11	2462	-12.63	8	PASS



CH1

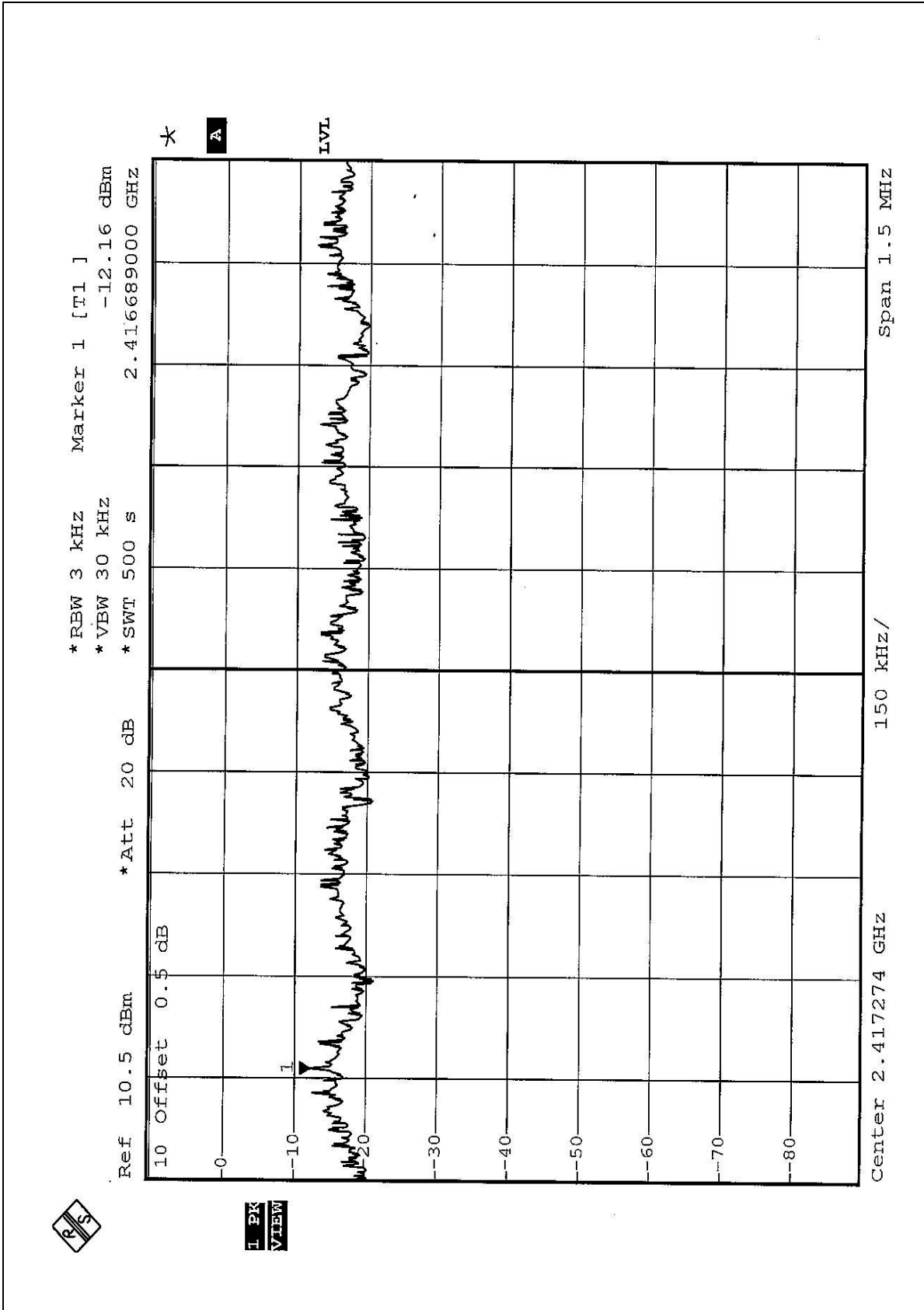



CH6

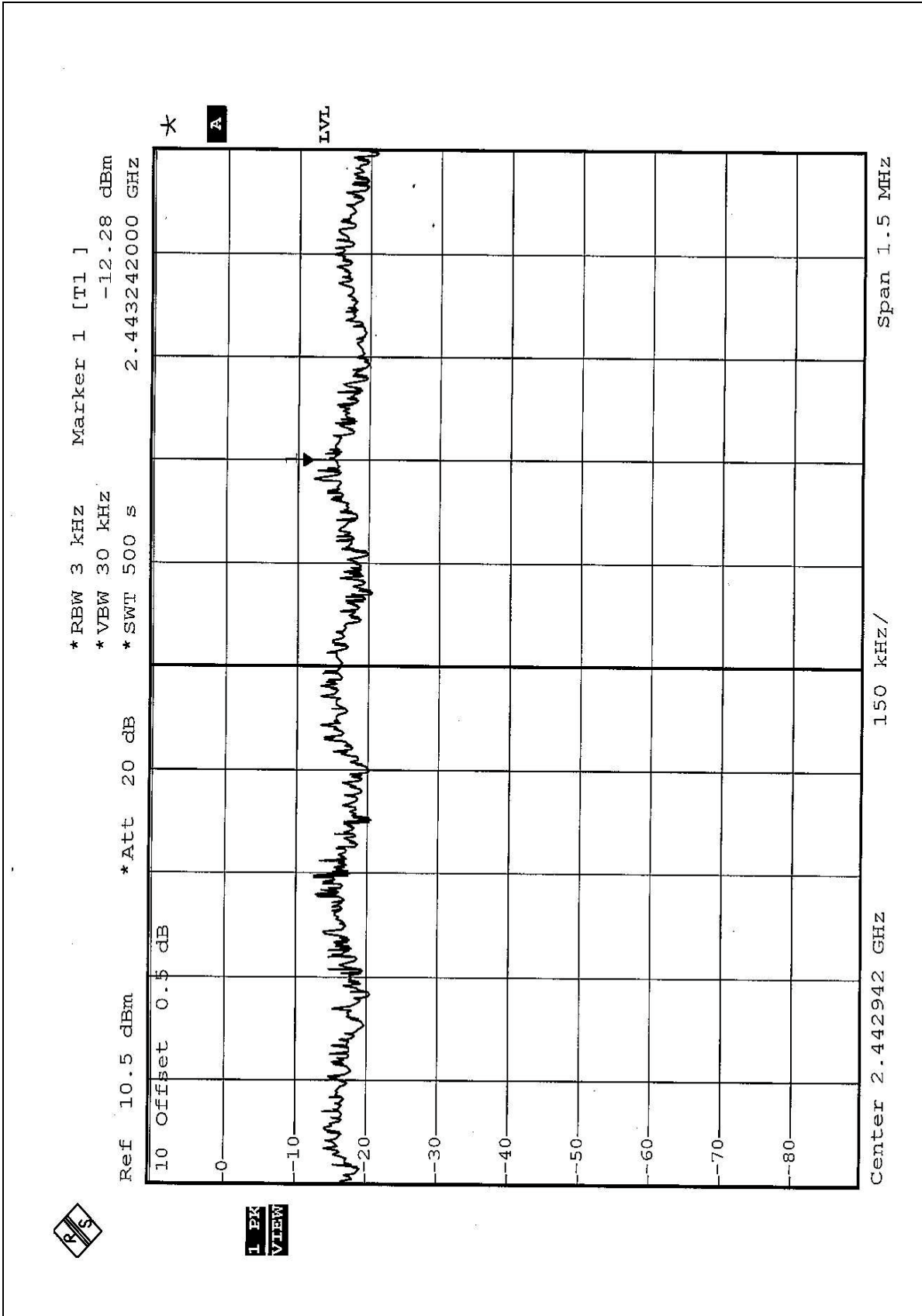



CH11

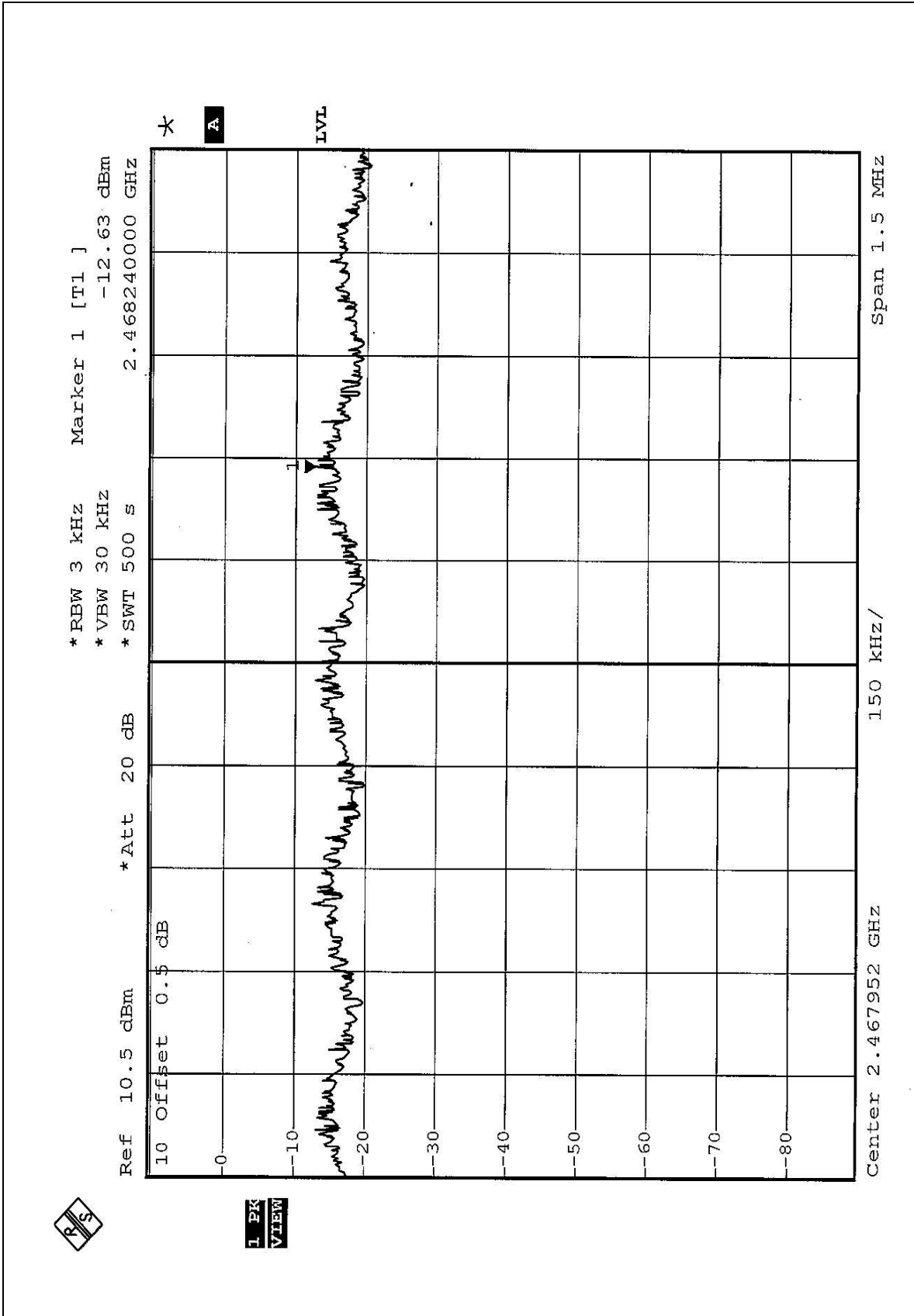



4.6 BAND EDGES MEASUREMENT

4.6.1 LIMITS OF BAND EDGES MEASUREMENT

Below -20dB of the highest emission level of operating band (in 100KHz Resolution Bandwidth).

4.6.2 TEST INSTRUMENTS

Description & Manufacturer	Model No.	Serial No.	Calibrated Until
SPECTRUM ANALYZER	FSEK30	100049	Aug. 12, 2004

NOTE: The calibration interval of the above test instruments is 12 months and the calibrations are traceable to NML/ROC and NIST/USA.

4.6.3 TEST PROCEDURE

The transmitter output was connected to the spectrum analyzer via a low lose cable. Set both RBW and VBW of spectrum analyzer to 100kHz and 100kHz with suitable frequency span including 100MHz bandwidth from band edge. The band edges was measured and recorded.

4.6.4 DEVIATION FROM TEST STANDARD

No deviation

4.6.5 EUT OPERATING CONDITION

Same as Item 4.3.6



4.6.6 TEST RESULTS

The spectrum plots are attached on the following 8 pages. D2 line indicates the highest level and D1 line indicates the 20dB offset below D2. It shows compliance with the requirement in part 15.247(C).

NOTE 1: The band edge emission plot of CCK technique on the following 1~2 pages show 56.18dB delta between carrier maximum power and local maximum emission in restrict band (2.3890GHz). The emission of carrier strength list in the test result of channel 1 at the item 4.2.7 is 101.24dBuV/m, so the maximum field strength in restrict band is $101.24 - 56.18 = 45.06$ dBuV/m which is under 54dBuV/m limit.

NOTE 2: The band edge emission plot of CCK technique on the following 3~4 pages show 56.87dB delta between carrier maximum power and local maximum emission in restrict band (2.4841GHz). The emission of carrier strength list in the test result of channel 11 at the item 4.2.7 is 103.37dBuV/m, so the maximum field strength in restrict band is $103.37 - 56.87 = 46.50$ dBuV/m which is under 54dBuV/m limit.

NOTE 3: The band edge emission plot of OFDM technique on the following 5~6 pages show 47.42dB delta between carrier maximum power and local maximum emission in restrict band (2.3900GHz). The emission of carrier strength list in the test result of channel 1 at the item 4.2.7 is 98.57dBuV/m, so the maximum field strength in restrict band is $98.57 - 47.42 = 51.15$ dBuV/m which is under 54dBuV/m limit.

NOTE 4: The band edge emission plot of OFDM technique on the following 7~8 pages show 48.97dB delta between carrier maximum power and local maximum emission in restrict band (2.4841GHz). The emission of carrier strength list in the test result of channel 11 at the item 4.2.7 is 97.87dBuV/m, so the maximum field strength in restrict band is $97.87 - 48.97 = 48.90$ dBuV/m which is under 54dBuV/m limit.

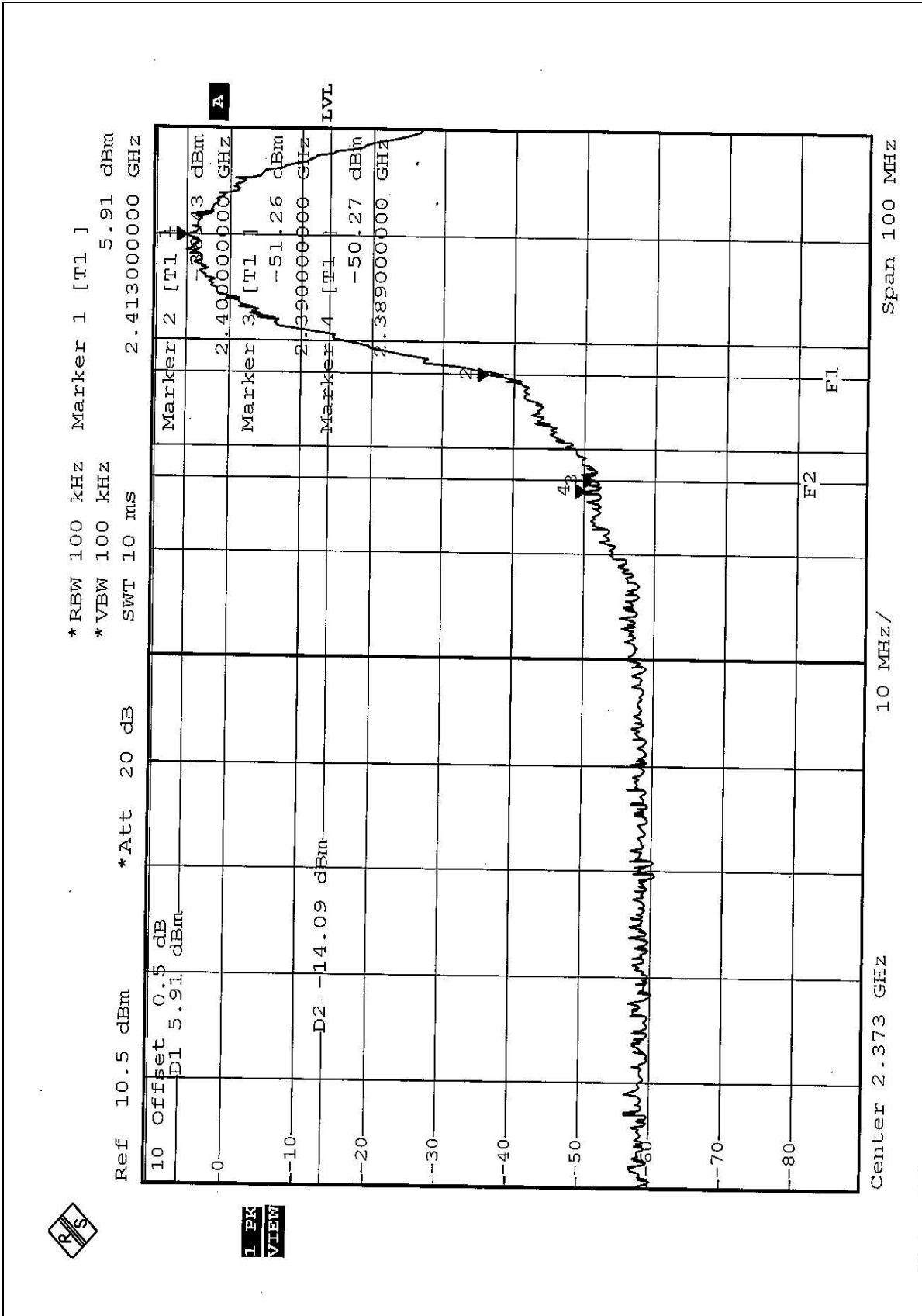

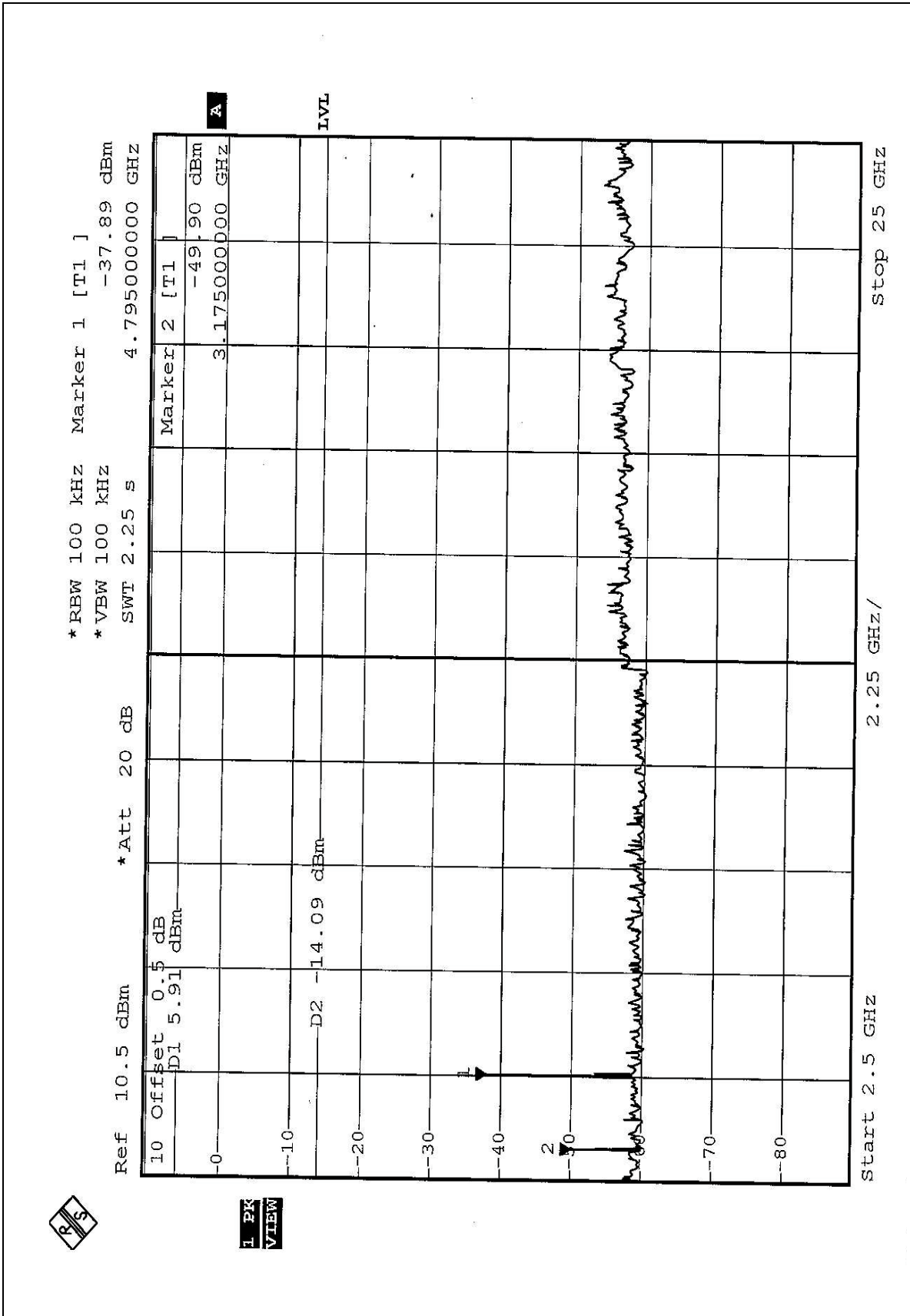

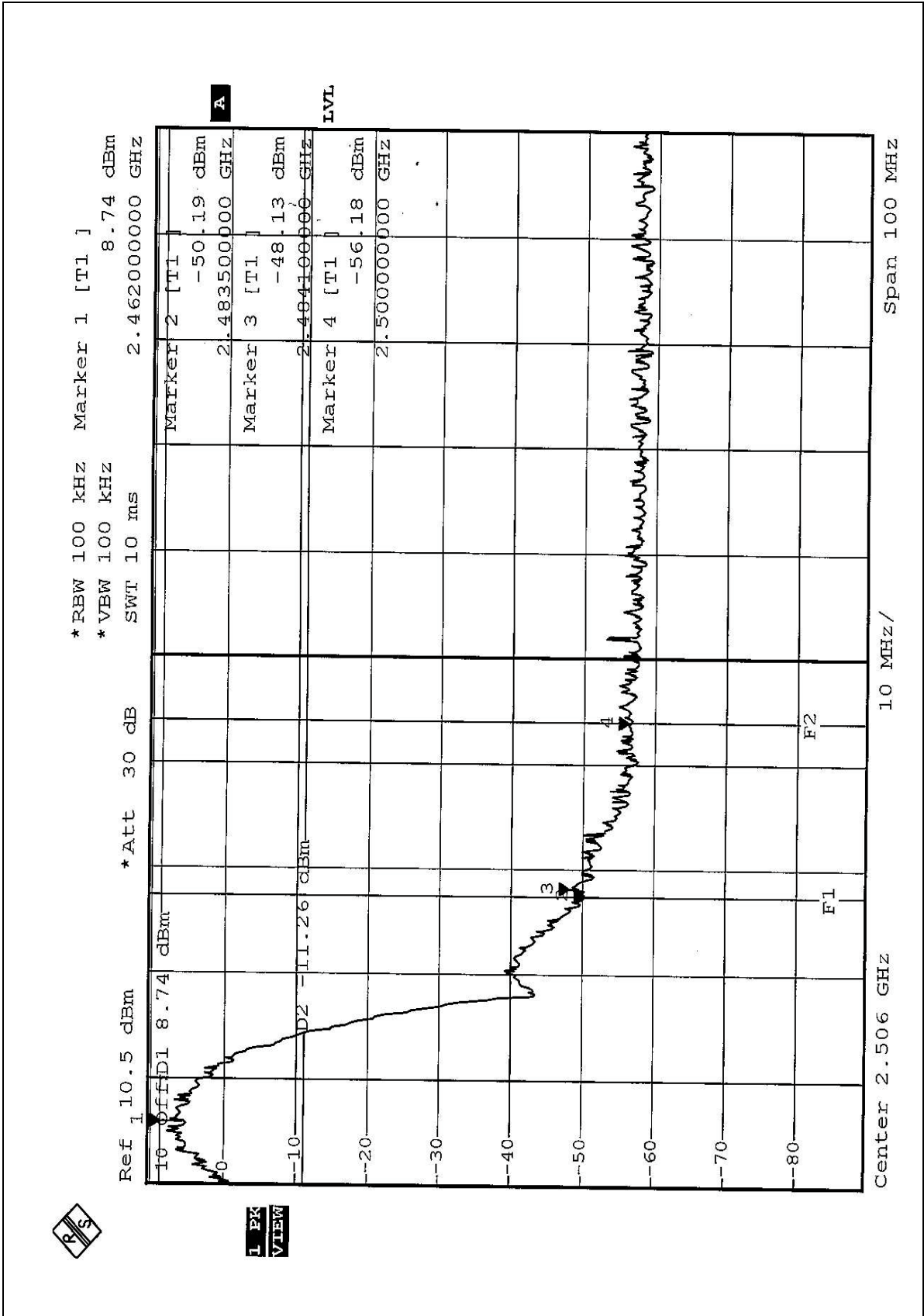

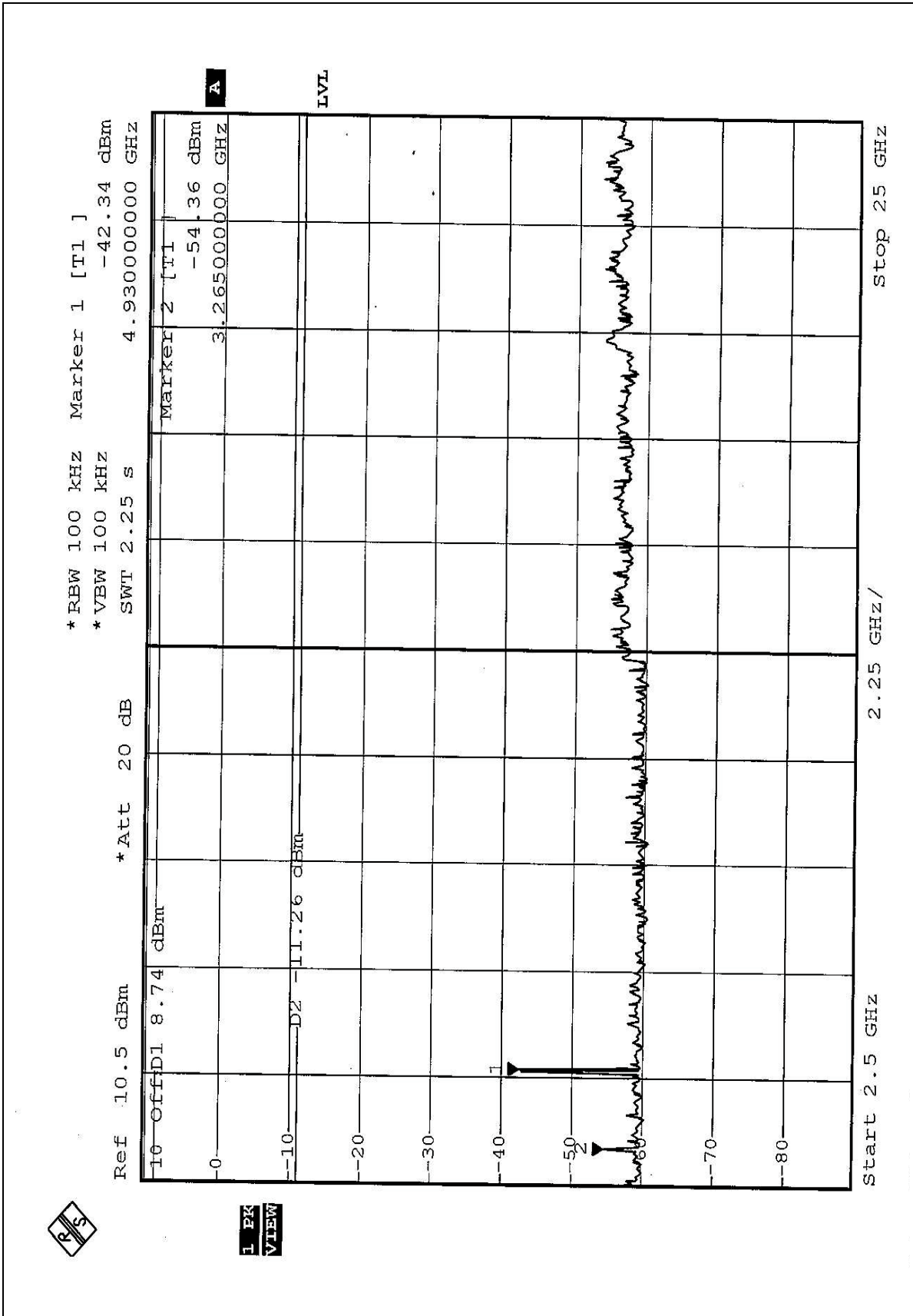

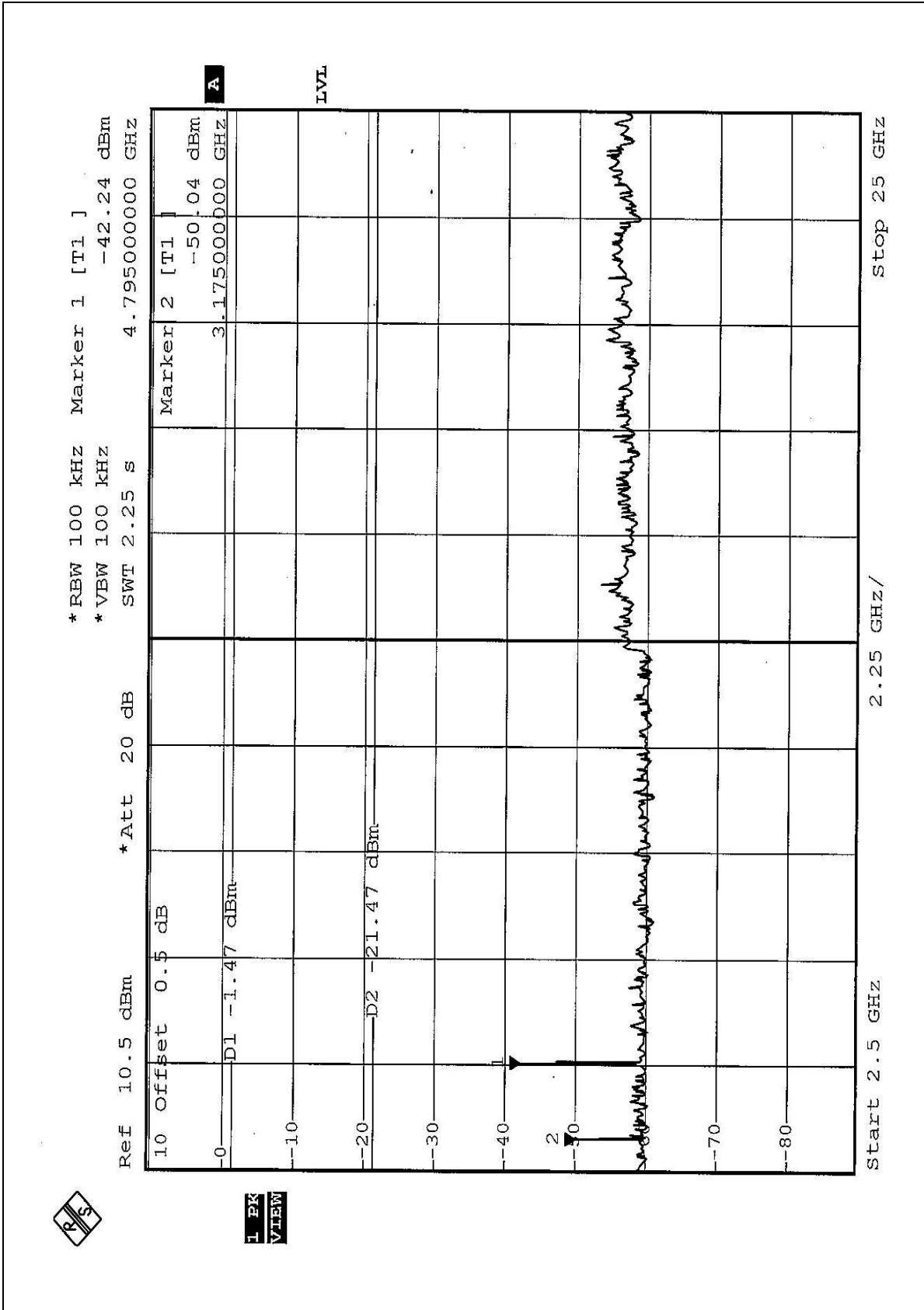

1 PK VIEW

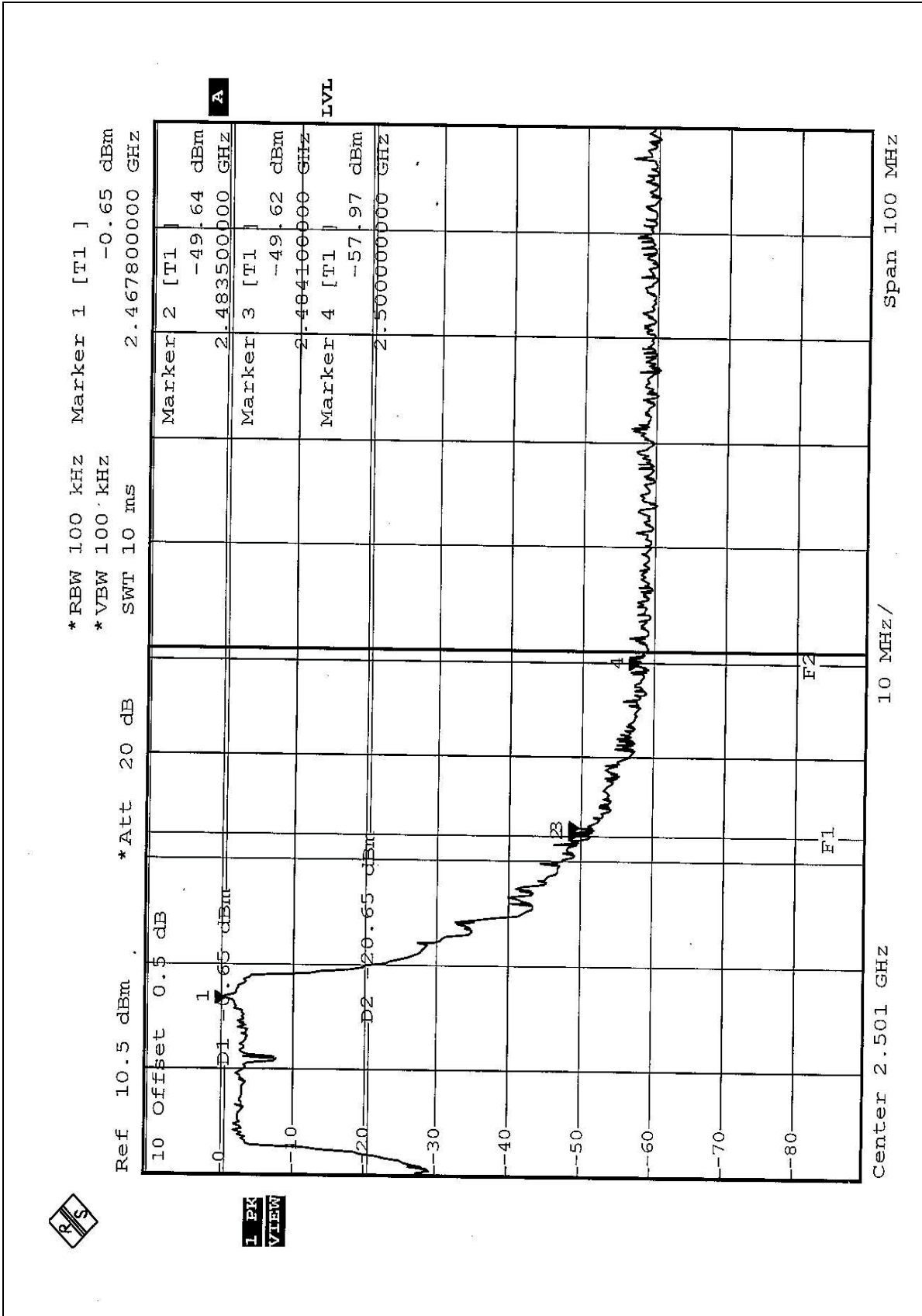

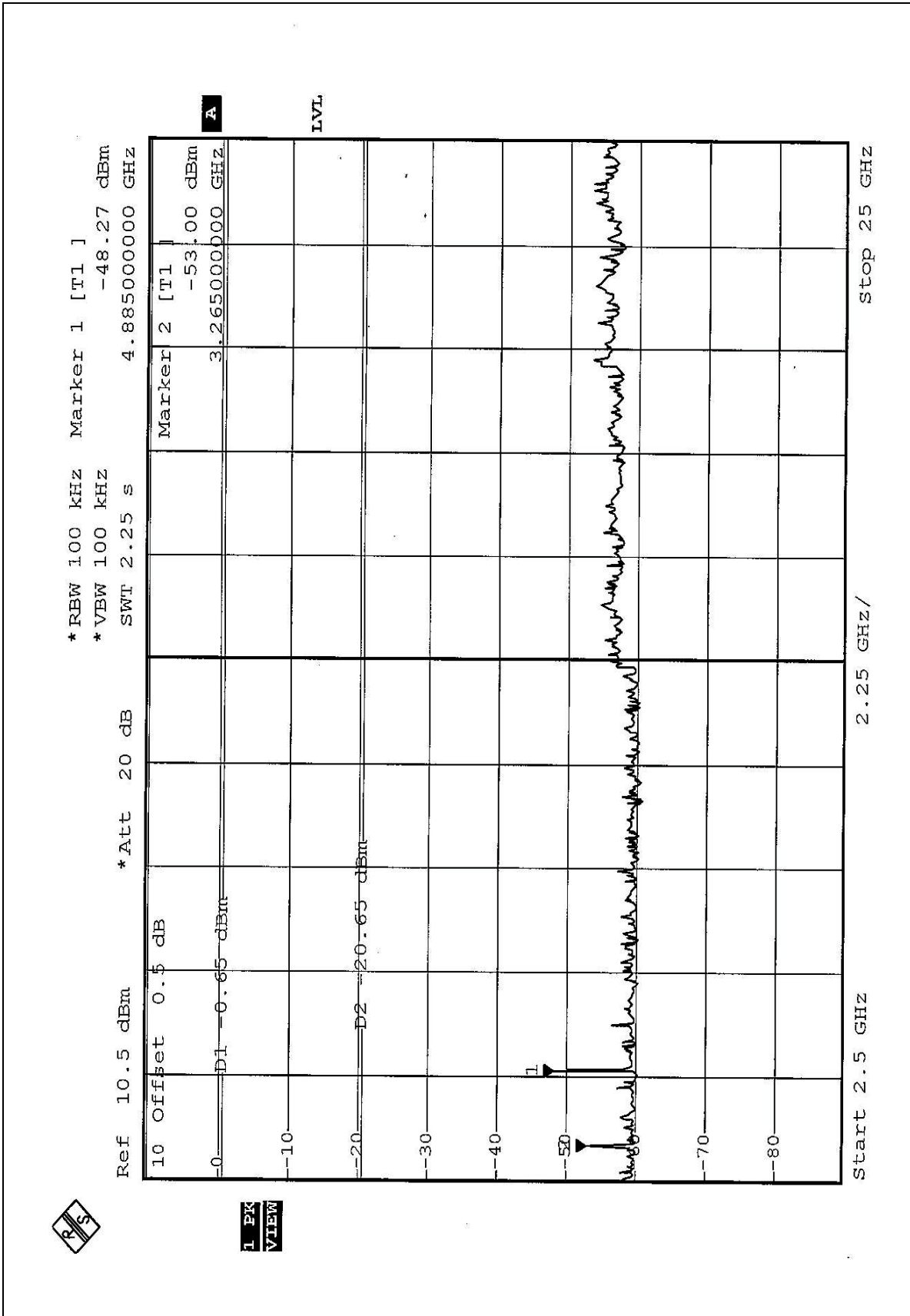



4.7 ANTENNA REQUIREMENT

4.7.1 STANDARD APPLICABLE

For intentional device, according to FCC 47 CFR Section 15.203, an intentional radiator shall be designed to ensure that no antenna other than that furnished by the responsible party shall be used with the device.

And according to FCC 47 CFR Section 15.247 (b), if transmitting antennas of directional gain greater than 6dBi are used, the power shall be reduced by the amount in dB that the directional gain of the antenna exceeds 6dBi.

4.7.2 ANTENNA CONNECTED CONSTRUCTION

The maximum Gain antennas used in this product is dipole antenna with UFL antenna connector. And the maximum Gain of these antennas is 2dBi.

5 PHOTOGRAPHS OF THE TEST CONFIGURATION

CONDUCTED EMISSION TEST





RADIATED EMISSION TEST







6 INFORMATION ON THE TESTING LABORATORIES

We, ADT Corp., were founded in 1988 to provide our best service in EMC, Radio, Telecom and Safety consultation. Our laboratories are accredited and approved by the following approval agencies according to ISO/IEC 17025, Guide 25 or EN 45001:

USA	FCC, NVLAP, UL
Germany	TUV Rheinland
Japan	VCCI
Norway	NEMKO
Canada	INDUSTRY CANADA , CSA
R.O.C.	CNLA, BSMI, DGT
Netherlands	Telefication
Singapore	PSB , GOST-ASIA(MOU)
Russia	CERTIS(MOU)

Copies of accreditation certificates of our laboratories obtained from approval agencies can be downloaded from our web site:

www.adt.com.tw/index.5/phtml. If you have any comments, please feel free to contact us at the following:

Linko EMC/RF Lab

Tel: 886-2-26052180
Fax: 886-2-26052943

Hsin Chu EMC/RF Lab

Tel: 886-3-5935343
Fax: 886-3-5935342

Hwa Ya EMC/RF/Safety Lab

Tel: 886-3-3183232
Fax: 886-3-3185050

Linko RF & Telecom Lab

Tel: 886-3-3270910
Fax: 886-3-3270892

Email: service@mail.adt.com.tw

Web Site: www.adt.com.tw

The address and road map of all our labs can be found in our web site also.