



# FCC TEST REPORT

**REPORT NO.:** RF930309R01  
**MODEL NO.:** WM1210  
**RECEIVED:** Mar. 9, 2004  
**TESTED:** Mar. 11 ~ Mar. 25, 2004

**APPLICANT:** CastleNet Technology Inc.

**ADDRESS:** 16F, No. 957, Chung Cheng Road,  
Cuhung-Ho City, Taipei Hsien, Taiwan, R.O.C.

**ISSUED BY:** Advance Data Technology Corporation

**LAB LOCATION:** 47 14th Lin, Chiapau Tsun, Linko, Taipei,  
Taiwan, R.O.C.

This test report consists of 67 pages in total. It may be duplicated completely for legal use with the approval of the applicant. It should not be reproduced except in full, without the written approval of our laboratory. The client should not use it to claim product endorsement by CNLA or any government agencies. The test results in the report only apply to the tested sample.



0528  
ILAC MRA



## Table of Contents

1	CERTIFICATION .....	4
2	SUMMARY OF TEST RESULTS .....	5
3	GENERAL INFORMATION .....	6
3.1	GENERAL DESCRIPTION OF EUT .....	6
3.2	DESCRIPTION OF TEST MODES .....	7
3.3	GENERAL DESCRIPTION OF APPLIED STANDARDS .....	7
3.4	DESCRIPTION OF SUPPORT UNITS .....	8
3.5	CONFIGURATION OF SYSTEM UNDER TEST .....	8
4	TEST TYPES AND RESULTS .....	9
4.1	CONDUCTED EMISSION MEASUREMENT .....	9
4.1.1	LIMITS OF CONDUCTED EMISSION MEASUREMENT .....	9
4.1.2	TEST INSTRUMENTS .....	9
4.1.3	TEST PROCEDURES .....	10
4.1.4	DEVIATION FROM TEST STANDARD .....	10
4.1.5	TEST SETUP .....	11
4.1.6	EUT OPERATING CONDITIONS .....	11
4.1.7	TEST RESULTS .....	12
4.2	RADIATED EMISSION MEASUREMENT .....	18
4.2.1	LIMITS OF RADIATED EMISSION MEASUREMENT .....	18
4.2.2	TEST INSTRUMENTS .....	19
4.2.3	TEST PROCEDURES .....	20
4.2.4	DEVIATION FROM TEST STANDARD .....	20
4.2.5	TEST SETUP .....	21
4.2.6	EUT OPERATING CONDITIONS .....	21
4.2.7	TEST RESULTS .....	22
4.3	6dB BANDWIDTH MEASUREMENT .....	30
4.3.1	LIMITS OF 6dB BANDWIDTH MEASUREMENT .....	30
4.3.2	TEST INSTRUMENTS .....	30
4.3.3	TEST PROCEDURE .....	30
4.3.4	DEVIATION FROM TEST STANDARD .....	30
4.3.5	TEST SETUP .....	30
4.3.6	EUT OPERATING CONDITIONS .....	30
4.3.7	TEST RESULTS .....	31



4.4	MAXIMUM PEAK OUTPUT POWER .....	39
4.4.1	LIMITS OF MAXIMUM PEAK OUTPUT POWER MEASUREMENT .....	39
4.4.2	TEST INSTRUMENTS .....	39
4.4.3	TEST PROCEDURES .....	40
4.4.4	DEVIATION FROM TEST STANDARD .....	40
4.4.5	TEST SETUP .....	40
4.4.6	EUT OPERATING CONDITIONS .....	40
4.4.7	TEST RESULTS .....	41
4.5	POWER SPECTRAL DENSITY MEASUREMENT .....	42
4.5.1	LIMITS OF POWER SPECTRAL DENSITY MEASUREMENT .....	42
4.5.2	TEST INSTRUMENTS .....	42
4.5.3	TEST PROCEDURE .....	42
4.5.4	DEVIATION FROM TEST STANDARD .....	42
4.5.5	TEST SETUP .....	42
4.5.6	EUT OPERATING CONDITIONS .....	42
4.5.7	TEST RESULTS .....	43
4.6	BAND EDGES MEASUREMENT .....	51
4.6.1	LIMITS OF BAND EDGES MEASUREMENT .....	51
4.6.2	TEST INSTRUMENTS .....	51
4.6.3	TEST PROCEDURE .....	51
4.6.4	DEVIATION FROM TEST STANDARD .....	51
4.6.5	EUT OPERATING CONDITION .....	51
4.6.6	TEST RESULTS .....	52
4.7	ANTENNA REQUIREMENT .....	62
4.7.1	STANDARD APPLICABLE .....	62
4.7.2	ANTENNA CONNECTED CONSTRUCTION .....	62
5	PHOTOGRAPHS OF THE TEST CONFIGURATION .....	63
6	INFORMATION ON THE TESTING LABORATORIES .....	67



# 1 CERTIFICATION

**PRODUCT :** Wireless 802.11g MiniPCI Card  
**MODEL NO.:** WM1210  
**BRAND:** CastleNet  
**APPLICANT :** CastleNet Technology Inc.  
**TESTED:** March 11 to March 25, 2004  
**TEST ITEM:** ENGINEERING SAMPLE  
**STANDARDS :** FCC Part 15, Subpart C (Section 15.247),  
ANSI C63.4-2001

The above equipment has been tested by **Advance Data Technology Corporation**, and found compliance with the requirement of the above standards. The test record, data evaluation and Equipment Under Test (EUT) configurations represented herein are true and accurate accounts of the measurements of the sample's EMC characteristics under the conditions herein specified.

**PREPARED BY:** Annie Chang, **DATE:** April 21, 2004  
Annie Chang

**APPROVED BY:** Ellis Wu, **DATE:** April 21, 2004  
Ellis Wu / Technical Manager



## 2 SUMMARY OF TEST RESULTS

The EUT has been tested according to the following specifications:

<b>APPLIED STANDARD: FCC Part 15, Subpart C</b>			
<b>Standard Section</b>	<b>Test Type and Limit</b>	<b>Result</b>	<b>REMARK</b>
15.207	AC Power Conducted Emission	PASS	Meet the requirement of limit Minimum passing margin is -14.80dB at 0.173MHz
15.247(a)(2)	Spectrum Bandwidth of a Direct Sequence Spread Spectrum System Limit : min. 500kHz	PASS	MEET THE REQUIREMENT OF LIMIT
15.247(b)	Maximum Peak Output Power Limit: max. 30dBm	PASS	Meet the requirement of limit
15.247(c)	Transmitter Radiated Emissions Limit: Table 15.209	PASS	Meet the requirement of limit Minimum passing margin is -2.55dB at 7386.00MHz
15.247(d)	Power Spectral Density Limit: max. 8dBm	PASS	MEET THE REQUIREMENT OF LIMIT
15.247(c)	Band Edge Measurement Limit: 20 dB less than the peak value of fundamental frequency	PASS	MEET THE REQUIREMENT OF LIMIT

**NOTE:** The information of measurement uncertainty is available upon the customer's request.



### 3 GENERAL INFORMATION

#### 3.1 GENERAL DESCRIPTION OF EUT

<b>PRODUCT</b>	Wireless 802.11g MiniPCI Card
<b>MODEL NO.</b>	WM1210
<b>POWER SUPPLY</b>	3.3Vdc from host equipment
<b>MODULATION TYPE</b>	BPSK, QPSK, CCK, 16QAM, 64QAM
<b>RADIO TECHNOLOGY</b>	DSSS, OFDM
<b>TRANSFER RATE</b>	802.11b: 11/5.5/2/1Mbps 802.11g: 54/48/36/24/18/12/9/6Mbps
<b>FREQUENCY RANGE</b>	2412MHz ~ 2462MHz
<b>NUMBER OF CHANNEL</b>	11
<b>MAXIMUM OUTPUT POWER</b>	18.04dBm
<b>ANTENNA TYPE</b>	Internal Dipole antenna with 2dBi antenna gain
<b>DATA CABLE</b>	NA
<b>I/O PORTS</b>	NA
<b>ASSOCIATED DEVICES</b>	NA

**NOTE:**

1. The EUT operates in the 2.4GHz frequency spectrum with throughput of up to 54Mbps.
2. The EUT complies with IEEE 802.11g draft standards and backwards compatible with IEEE 802.11b products.
3. The above EUT information was declared by manufacturer and for a more detailed features description, please refer to the manufacturer's specifications or User's Manual.



### 3.2 DESCRIPTION OF TEST MODES

Eleven channels are provided to this EUT.

Channel	Frequency	Channel	Frequency
1	2412 MHz	7	2442 MHz
2	2417 MHz	8	2447 MHz
3	2422 MHz	9	2452 MHz
4	2427 MHz	10	2457 MHz
5	2432 MHz	11	2462 MHz
6	2437 MHz		

**NOTE:**

1. Below 1GHz, the channel 1, 6, and 11 were pre-tested in chamber. The channel 11, worst case one, was chosen for final test.
2. Above 1GHz, the channel 1, 6, and 11 were tested individually.
3. Transfer rate, 11Mbps with CCK technique and 6Mbps with OFDM technique, the worst cases, were chosen for final test.
4. For our experience and technical viewpoint, we have chosen data rates-11Mbps for CCK technique and 6Mbps for OFDM technique-as the worst cases for the test among other data rates.

### 3.3 GENERAL DESCRIPTION OF APPLIED STANDARDS

The EUT is a Wireless 802.11g MiniPCI Card. According to the specifications of the manufacturer, it must comply with the requirements of the following standards:

**FCC Part 15, Subpart C. (15.247)**  
**ANSI C63.4 : 2001**

All test items have been performed and recorded as per the above standards.

**NOTE:** The EUT is also considered as a kind of computer peripheral, because the connection to computer is necessary for typical use. It has been verified to comply with the requirements of FCC Part 15, Subpart B, Class B (DoC). The test report has been issued separately.



### 3.4 DESCRIPTION OF SUPPORT UNITS

The EUT has been tested as an independent unit together with other necessary accessories or support units. The following support units or accessories were used to form a representative test configuration during the tests.

NO.	PRODUCT	BRAND	MODEL NO.	SERIAL NO.	FCC ID
1	NOTEBOOK	DELL	PP05L	7T390 A02	FCC DoC Approved
2	PRINTER	EPSON	LQ-300+	DCGY017058	FCC DoC Approved
3	MODEM	ACEEX	1414	980020519	IFAXDM1414

NO.	SIGNAL CABLE DESCRIPTION OF THE ABOVE SUPPORT UNITS
1	NA
2	1.2m braid shielded wire, terminated with DB25 and Centronics connector via metallic frame, w/o core
3	1.2 m braid shielded wire, terminated with DB25 and DB9 connector via metallic frame, w/o core.

**NOTE:** All power cords of the above support units are non-shielded (1.8m).

### 3.5 CONFIGURATION OF SYSTEM UNDER TEST

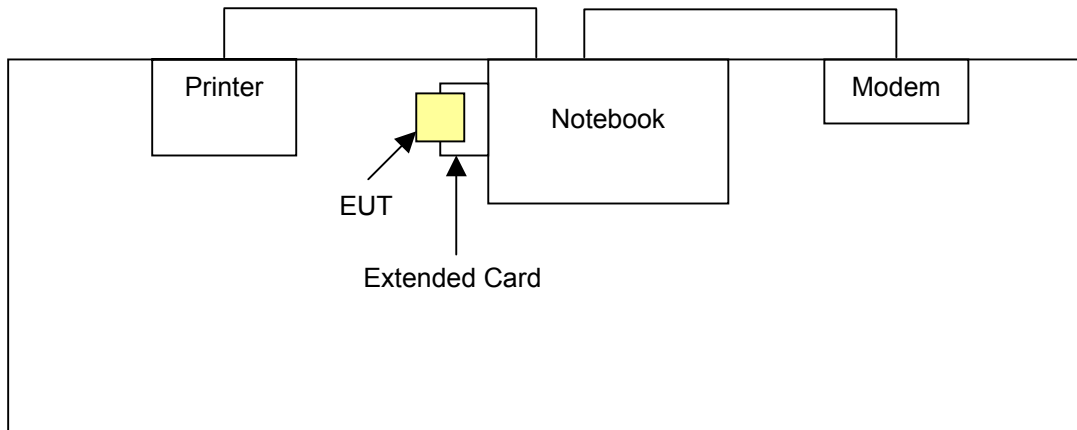





## 4 TEST TYPES AND RESULTS

### 4.1 CONDUCTED EMISSION MEASUREMENT

#### 4.1.1 LIMITS OF CONDUCTED EMISSION MEASUREMENT

FREQUENCY OF EMISSION (MHz)	CONDUCTED LIMIT (dB $\mu$ V)	
	Quasi-peak	Average
0.15-0.5	66 to 56	56 to 46
0.5-5	56	46
5-30	60	50

- NOTE:**
1. The lower limit shall apply at the transition frequencies.
  2. The limit decreases in line with the logarithm of the frequency in the range of 0.15 to 0.50 MHz.
  3. All emanations from a class A/B digital device or system, including any network of conductors and apparatus connected thereto, shall not exceed the level of field strengths specified above.

#### 4.1.2 TEST INSTRUMENTS

DESCRIPTION & MANUFACTURER	MODEL NO.	SERIAL NO.	CALIBRATED UNTIL
ROHDE & SCHWARZ Test Receiver	ESCS 30	838251/021	Jan. 04, 2005
ROHDE & SCHWARZ Artificial Mains Network (for EUT)	ESH3-Z5	100218	Dec. 09, 2004
ROHDE & SCHWARZ Artificial Mains Network (for peripherals)	ESH3-Z5	100219	Dec. 09, 2004
ROHDE & SCHWARZ Artificial Mains Network (for peripherals)	ESH3-Z5	100220	Dec. 09, 2004
*ROHDE & SCHWARZ 4-wire ISN	ENY41	837032/016	Nov. 19, 2004
*ROHDE & SCHWARZ 2-wire ISN	ENY22	837497/016	Nov. 19, 2004
Software	Cond-V2M3	NA	NA
RF cable (JYEBAO)	5D-FB	Cable-C10.01	May 01, 2004
SUHNTER Terminator (For ROHDE & SCHWARZ LISN)	65BNC-5001	E1-010770	Feb. 28, 2005
SUHNTER Terminator (For ROHDE & SCHWARZ LISN)	65BNC-5001	E1-010773	Feb. 28, 2005

- NOTE:**
1. The calibration interval of the above test instruments is 12 months and the calibrations are traceable to NML/ROC and NIST/USA.
  2. “\*”: These equipment are used for conducted telecom port test only (if tested).
  3. The test was performed in ADT Shielded Room No. 10.
  4. The VCCI Site Registration No. is C-1312.



#### 4.1.3 TEST PROCEDURES

- a. The EUT was placed 0.4 meters from the conducting wall of the shielded room with EUT being connected to the power mains through a line impedance stabilization network (LISN). Other support units were connected to the power mains through another LISN. The two LISNs provide 50 ohm/ 50uH of coupling impedance for the measuring instrument.
- b. Both lines of the power mains connected to the EUT were checked for maximum conducted interference.
- c. The frequency range from 150kHz to 30MHz was searched. Emission levels under (Limit -20dB) was not recorded.

#### 4.1.4 DEVIATION FROM TEST STANDARD

No deviation

#### 4.1.5 TEST SETUP

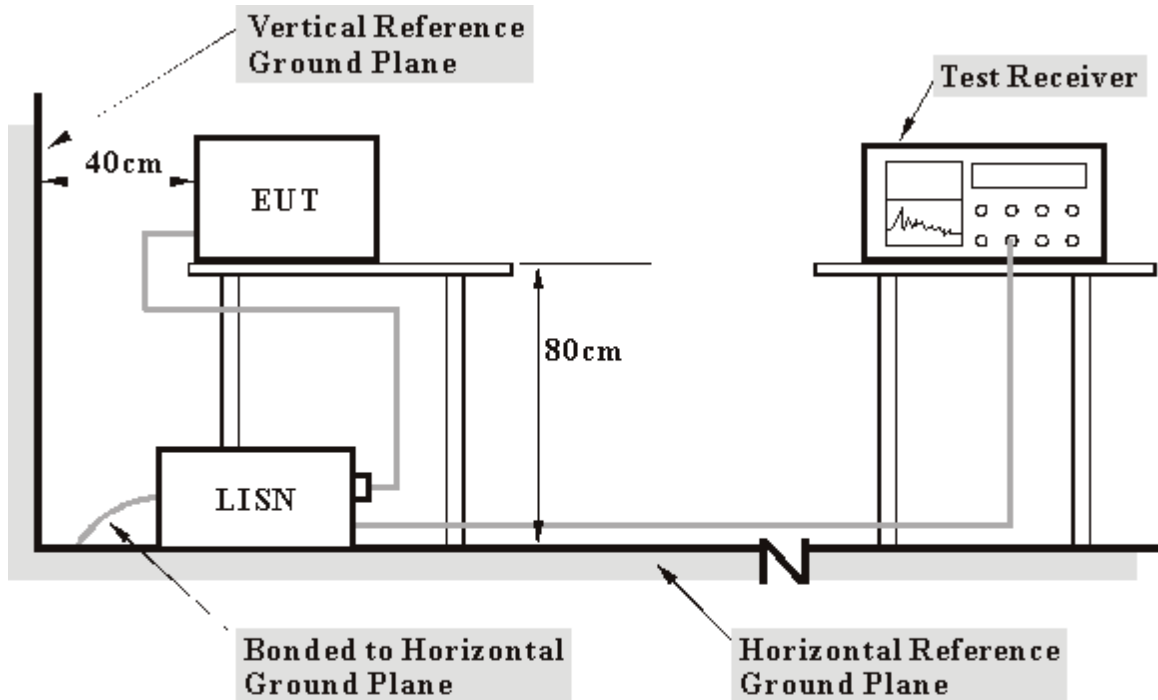

- Note:**
1. Support units were connected to second LISN.
  2. Both of LISNs (AMN) 80 cm from EUT and at the least 80 cm from other units and other metal planes support units.

For the actual test configuration, please refer to the related item – Photographs of the Test Configuration.

#### 4.1.6 EUT OPERATING CONDITIONS

- a. Plug the EUT a notebook system placed on a testing table.
- b. The notebook system ran a test program (provided by manufacturer) to enable EUT under transmission/receiving condition continuously at specific channel frequency.
- c. The notebook system sent "H" messages to its screen.
- d. The notebook system sent "H" messages to modem.
- e. The notebook system sent "H" messages to printer, and the printer prints them on paper.
- f. Steps c~e were repeated.



4.1.7 TEST RESULTS

<b>EUT</b>	Wireless 802.11g MiniPCI Card	<b>MODEL</b>	WM1210
<b>CHANNEL</b>	1	<b>6dB BANDWIDTH</b>	9kHz
<b>INPUT POWER (SYSTEM)</b>	120Vac, 60Hz	<b>PHASE</b>	Line (L)
<b>ENVIRONMENTAL CONDITIONS</b>	20deg. C, 75%RH, 991hPa	<b>TESTED BY:</b> Jamison Chan	

No	Freq. [MHz]	Corr. Factor (dB)	Reading Value		Emission Level		Limit		Margin	
			[dB (uV)]		[dB (uV)]		[dB (uV)]		(dB)	
			Q.P.	AV.	Q.P.	AV.	Q.P.	AV.	Q.P.	AV.
1	0.154	0.10	50.30	-	50.40	-	65.79	55.79	-15.39	-
<b>2</b>	<b>0.173</b>	<b>0.10</b>	<b>49.89</b>	-	<b>49.99</b>	-	<b>64.79</b>	<b>54.79</b>	<b>-14.80</b>	-
3	0.189	0.10	47.79	-	47.89	-	64.08	54.08	-16.19	-
4	0.244	0.10	41.90	-	42.00	-	61.97	51.97	-19.97	-
5	8.539	0.53	35.73	-	36.26	-	60.00	50.00	-23.74	-
6	10.102	0.60	32.61	-	33.21	-	60.00	50.00	-26.79	-

- REMARKS:**
1. Q.P. and AV. are abbreviations of quasi-peak and average individually.
  2. "-": The Quasi-peak reading value also meets average limit and measurement with the average detector is unnecessary.
  3. The emission levels of other frequencies were very low against the limit.
  4. Margin value = Emission level - Limit value
  5. Correction factor = Insertion loss + Cable loss
  6. Emission Level = Correction Factor + Reading Value.

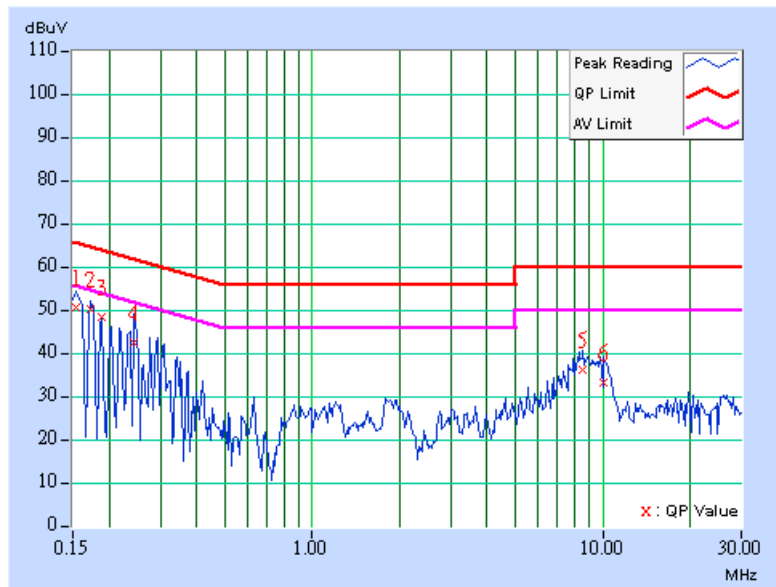



<b>EUT</b>	Wireless 802.11g MiniPCI Card	<b>MODEL</b>	WM1210
<b>CHANNEL</b>	1	<b>6dB BANDWIDTH</b>	9kHz
<b>INPUT POWER (SYSTEM)</b>	120Vac, 60Hz	<b>PHASE</b>	Neutral (N)
<b>ENVIRONMENTAL CONDITIONS</b>	20deg. C, 75%RH, 991hPa	<b>TESTED BY:</b> Jamison Chan	

No	Freq. [MHz]	Corr. Factor (dB)	Reading Value [dB (uV)]		Emission Level [dB (uV)]		Limit [dB (uV)]		Margin (dB)	
			Q.P.	AV.	Q.P.	AV.	Q.P.	AV.	Q.P.	AV.
			1	0.170	0.10	48.95	-	49.05	-	64.98
2	0.189	0.10	46.70	-	46.80	-	64.08	54.08	-17.28	-
3	0.205	0.10	42.81	-	42.91	-	63.42	53.42	-20.51	-
4	0.295	0.10	33.24	-	33.34	-	60.40	50.40	-27.06	-
5	7.855	0.43	32.50	-	32.93	-	60.00	50.00	-27.07	-
6	10.039	0.50	33.62	-	34.12	-	60.00	50.00	-25.88	-

- REMARKS:**
1. Q.P. and AV. are abbreviations of quasi-peak and average individually.
  2. "-": The Quasi-peak reading value also meets average limit and measurement with the average detector is unnecessary.
  3. The emission levels of other frequencies were very low against the limit.
  4. Margin value = Emission level - Limit value
  5. Correction factor = Insertion loss + Cable loss
  6. Emission Level = Correction Factor + Reading Value.

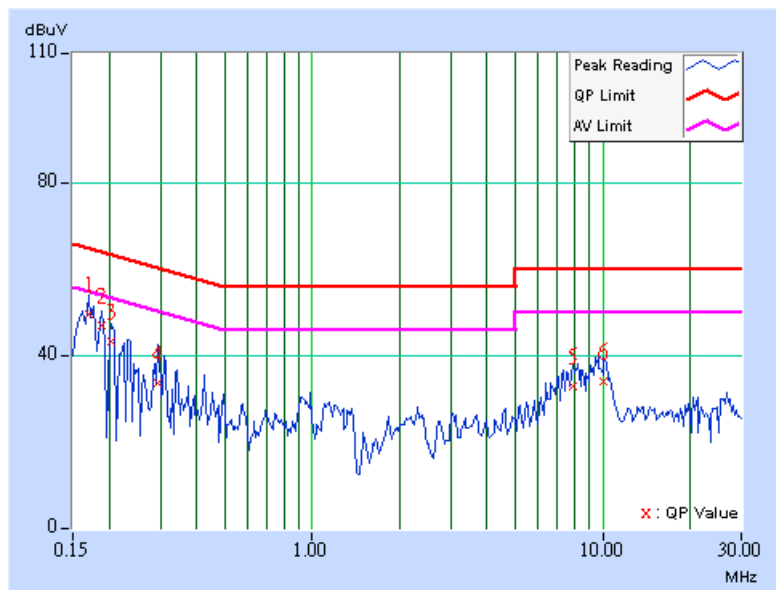



<b>EUT</b>	Wireless 802.11g MiniPCI Card	<b>MODEL</b>	WM1210
<b>CHANNEL</b>	6	<b>6dB BANDWIDTH</b>	9kHz
<b>INPUT POWER (SYSTEM)</b>	120Vac, 60Hz	<b>PHASE</b>	Line (L)
<b>ENVIRONMENTAL CONDITIONS</b>	20deg. C, 75%RH, 991hPa	<b>TESTED BY:</b> Jamison Chan	

No	Freq. [MHz]	Corr. Factor [dB]	Reading Value [dB (uV)]		Emission Level [dB (uV)]		Limit [dB (uV)]		Margin (dB)	
			Q.P.	AV.	Q.P.	AV.	Q.P.	AV.	Q.P.	AV.
			1	0.150	0.10	47.86	-	47.96	-	66.00
2	0.173	0.10	45.47	-	45.57	-	64.79	54.79	-19.22	-
3	0.189	0.10	45.01	-	45.11	-	64.08	54.08	-18.97	-
4	0.205	0.10	44.69	-	44.79	-	63.42	53.42	-18.63	-
5	7.969	0.50	30.07	-	30.57	-	60.00	50.00	-29.43	-
6	8.461	0.52	35.54	-	36.06	-	60.00	50.00	-23.94	-

- REMARKS:**
1. Q.P. and AV. are abbreviations of quasi-peak and average individually.
  2. "-": The Quasi-peak reading value also meets average limit and measurement with the average detector is unnecessary.
  3. The emission levels of other frequencies were very low against the limit.
  4. Margin value = Emission level - Limit value
  5. Correction factor = Insertion loss + Cable loss
  6. Emission Level = Correction Factor + Reading Value.

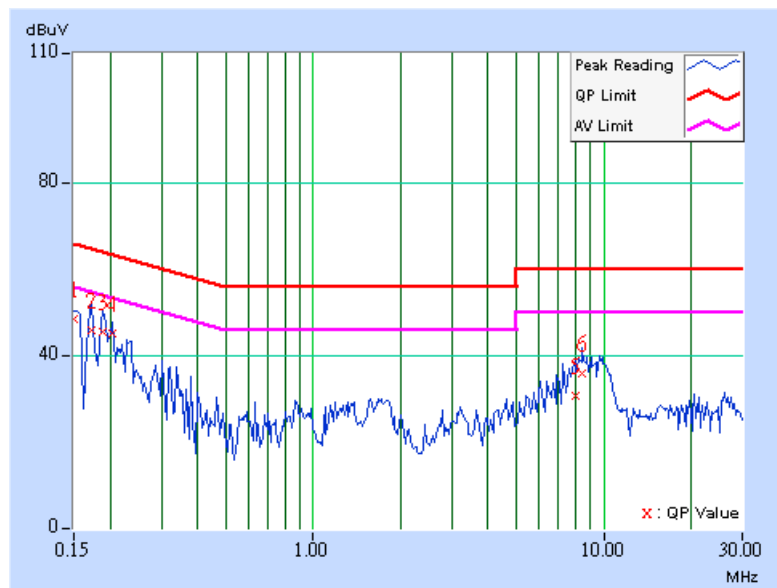



<b>EUT</b>	Wireless 802.11g MiniPCI Card	<b>MODEL</b>	WM1210
<b>CHANNEL</b>	6	<b>6dB BANDWIDTH</b>	9kHz
<b>INPUT POWER (SYSTEM)</b>	120Vac, 60Hz	<b>PHASE</b>	Neutral (N)
<b>ENVIRONMENTAL CONDITIONS</b>	20deg. C, 75%RH, 991hPa	<b>TESTED BY:</b> Jamison Chan	

No	Freq. [MHz]	Corr. Factor (dB)	Reading Value [dB (uV)]		Emission Level [dB (uV)]		Limit [dB (uV)]		Margin (dB)	
			Q.P.	AV.	Q.P.	AV.	Q.P.	AV.	Q.P.	AV.
			1	0.162	0.10	47.93	-	48.03	-	65.38
2	0.173	0.10	47.07	-	47.17	-	64.79	54.79	-17.62	-
3	0.189	0.10	45.63	-	45.73	-	64.08	54.08	-18.35	-
4	0.224	0.10	40.87	-	40.97	-	62.66	52.66	-21.69	-
5	8.023	0.43	27.96	-	28.39	-	60.00	50.00	-31.61	-
6	10.047	0.50	33.50	-	34.00	-	60.00	50.00	-26.00	-

- REMARKS:**
1. Q.P. and AV. are abbreviations of quasi-peak and average individually.
  2. "-": The Quasi-peak reading value also meets average limit and measurement with the average detector is unnecessary.
  3. The emission levels of other frequencies were very low against the limit.
  4. Margin value = Emission level - Limit value
  5. Correction factor = Insertion loss + Cable loss
  6. Emission Level = Correction Factor + Reading Value.

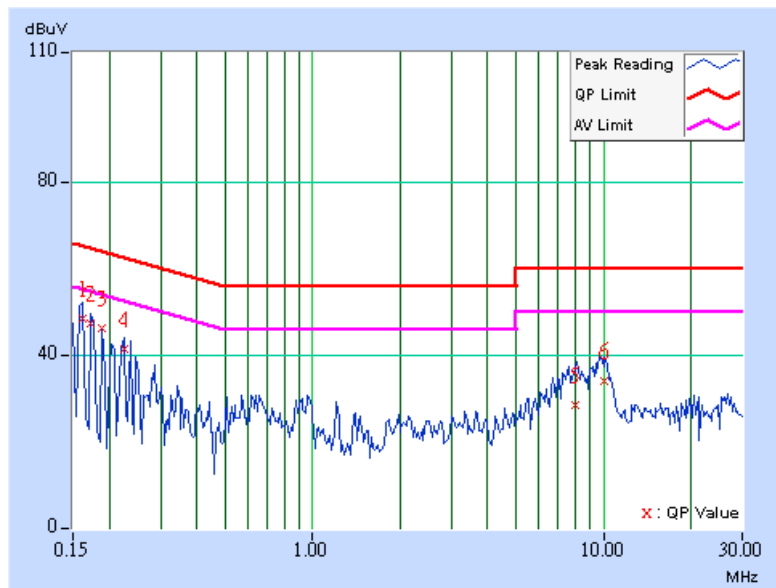



<b>EUT</b>	Wireless 802.11g MiniPCI Card	<b>MODEL</b>	WM1210
<b>CHANNEL</b>	11	<b>6dB BANDWIDTH</b>	9kHz
<b>INPUT POWER (SYSTEM)</b>	120Vac, 60Hz	<b>PHASE</b>	Line (L)
<b>ENVIRONMENTAL CONDITIONS</b>	20deg. C, 75%RH, 991hPa	<b>TESTED BY:</b> Jamison Chan	

No	Freq. [MHz]	Corr. Factor (dB)	Reading Value		Emission Level		Limit		Margin	
			[dB (uV)]		[dB (uV)]		[dB (uV)]		(dB)	
			Q.P.	AV.	Q.P.	AV.	Q.P.	AV.	Q.P.	AV.
1	0.166	0.10	45.37	-	45.47	-	65.18	55.18	-19.71	-
2	0.181	0.10	44.88	-	44.98	-	64.43	54.43	-19.45	-
3	0.209	0.10	43.63	-	43.73	-	63.26	53.26	-19.53	-
4	0.252	0.10	36.91	-	37.01	-	61.71	51.71	-24.70	-
5	8.184	0.51	34.90	-	35.41	-	60.00	50.00	-24.59	-
6	8.484	0.52	35.08	-	35.60	-	60.00	50.00	-24.40	-

- REMARKS:**
1. Q.P. and AV. are abbreviations of quasi-peak and average individually.
  2. "-": The Quasi-peak reading value also meets average limit and measurement with the average detector is unnecessary.
  3. The emission levels of other frequencies were very low against the limit.
  4. Margin value = Emission level - Limit value
  5. Correction factor = Insertion loss + Cable loss
  6. Emission Level = Correction Factor + Reading Value.

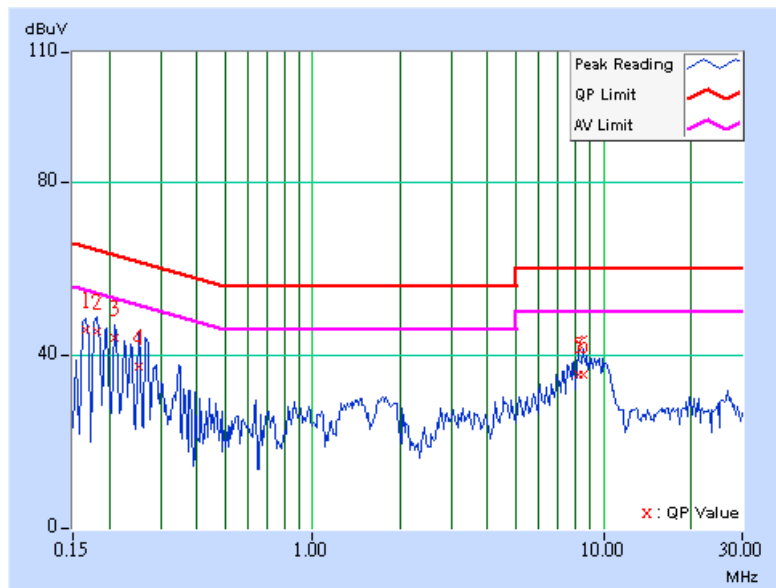





<b>EUT</b>	Wireless 802.11g MiniPCI Card	<b>MODEL</b>	WM1210
<b>CHANNEL</b>	11	<b>6dB BANDWIDTH</b>	9kHz
<b>INPUT POWER (SYSTEM)</b>	120Vac, 60Hz	<b>PHASE</b>	Neutral (N)
<b>ENVIRONMENTAL CONDITIONS</b>	20deg. C, 75%RH, 991hPa	<b>TESTED BY:</b> Jamison Chan	

No	Freq. [MHz]	Corr. Factor (dB)	Reading Value [dB (uV)]		Emission Level [dB (uV)]		Limit [dB (uV)]		Margin (dB)	
			Q.P.	AV.	Q.P.	AV.	Q.P.	AV.	Q.P.	AV.
			1	0.150	0.10	48.46	-	48.56	-	66.00
2	0.170	0.10	46.41	-	46.51	-	64.98	54.98	-18.47	-
3	0.185	0.10	43.60	-	43.70	-	64.25	54.25	-20.55	-
4	0.216	0.10	42.52	-	42.62	-	62.96	52.96	-20.34	-
5	8.141	0.44	33.51	-	33.95	-	60.00	50.00	-26.05	-
6	9.949	0.50	34.41	-	34.91	-	60.00	50.00	-25.09	-

- REMARKS:**
1. Q.P. and AV. are abbreviations of quasi-peak and average individually.
  2. "-": The Quasi-peak reading value also meets average limit and measurement with the average detector is unnecessary.
  3. The emission levels of other frequencies were very low against the limit.
  4. Margin value = Emission level - Limit value
  5. Correction factor = Insertion loss + Cable loss
  6. Emission Level = Correction Factor + Reading Value.

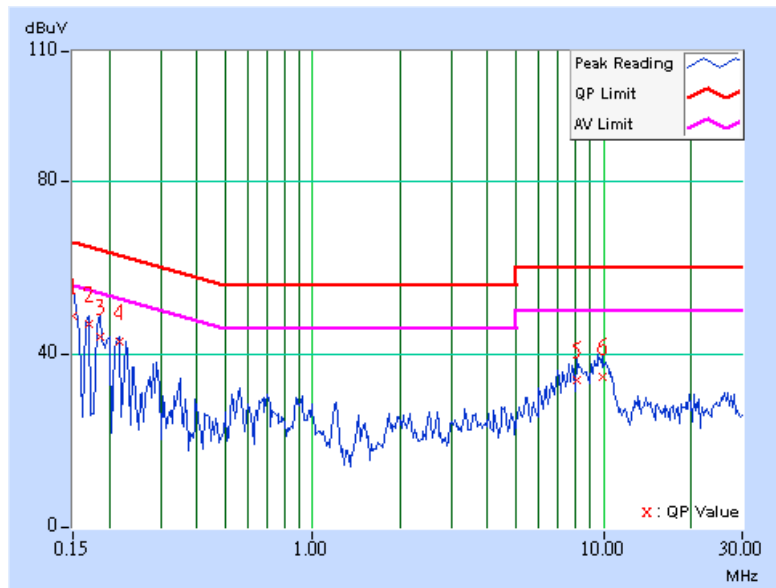



## 4.2 RADIATED EMISSION MEASUREMENT

### 4.2.1 LIMITS OF RADIATED EMISSION MEASUREMENT

Emissions radiated outside of the specified bands, shall be according to the general radiated limits in 15.209 as following:

Frequencies (MHz)	Field strength (microvolts/meter)	Measurement distance (meters)
0.009-0.490	2400/F(kHz)	300
0.490-1.705	24000/F(kHz)	30
1.705-30.0	30	30
30-88	100	3
88-216	150	3
216-960	200	3
Above 960	500	3

**NOTE:**

1. The lower limit shall apply at the transition frequencies.
2. Emission level (dBuV/m) = 20 log Emission level (uV/m).
3. As shown in 15.35(b), for frequencies above 1000MHz, the field strength limits are based on average detector, however, the peak field strength of any emission shall not exceed the maximum permitted average limits, specified above by more than 20dB under any condition of modulation.



## 4.2.2 TEST INSTRUMENTS

DESCRIPTION & MANUFACTURER	MODEL NO.	SERIAL NO.	CALIBRATED UNTIL
* HP Spectrum Analyzer	8593E	3911A07465	Jul. 7, 2004
* HP Preamplifier	8447D	2432A03504	Jun. 10, 2004
* HP Preamplifier	8449B	3008A01292	Aug. 11, 2004
SCHAFFNER Tunable Dipole Antenna	VHBA 9123	459	Jun. 26, 2004
SCHWARZBECK Tunable Dipole Antenna	UHA 9105	977	
* ROHDE & SCHWARZ Test Receiver	ESI7	838496/016	Feb. 08, 2005
* Schwarzbeck Antenna	VULB9168	137	Feb. 27, 2005
* SCHWARZBECK Horn Antenna	BBHA9120-D1	D130	Jun. 30, 2004
* ADT. Turn Table	TT100	0306	NA
* ADT. Tower	AT100	0306	NA
* Software	ADT_Radiated_V5.14	NA	NA
* TIMES RF cable	LL142	CABLE-CH6-01	Apr. 30, 2004

- NOTE:** 1. The calibration interval of the above test instruments is 12 months. And the calibrations are traceable to NML/ROC and NIST/USA.
2. "\*" = These equipment are used for the final measurement.
3. The horn antenna and HP preamplifier (model: 8449B) are used only for the measurement of emission frequency above 1GHz if tested.
4. The test was performed in ADT Chamber No. 6.



### 4.2.3 TEST PROCEDURES

- a. The EUT was placed on the top of a rotating table 0.8 meters above the ground at a 10 meter open area test site. The table was rotated 360 degrees to determine the position of the highest radiation.
- b. The EUT was set 3 meters away from the interference-receiving antenna, which was mounted on the top of a variable-height antenna tower.
- c. The antenna is a broadband antenna, and its height is varied from one meter to four meters above the ground to determine the maximum value of the field strength. Both horizontal and vertical polarizations of the antenna are set to make the measurement.
- d. For each suspected emission, the EUT was arranged to its worst case and then the antenna was tuned to heights from 1 meter to 4 meters and the rotatable table was turned from 0 degrees to 360 degrees to find the maximum reading.
- e. The test-receiver system was set to Peak Detect Function and Specified Bandwidth with Maximum Hold Mode.
- f. If the emission level of the EUT in peak mode was 10 dB lower than the limit specified, then testing could be stopped and the peak values of the EUT would be reported. Otherwise the emissions that did not have 10 dB margin would be re-tested one by one using peak, quasi-peak or average method as specified and then reported in a data sheet.

**NOTE:**

1. The resolution bandwidth and video bandwidth of test receiver/spectrum analyzer is 120kHz for Peak detection (PK) and Quasi-peak detection (QP) at frequency below 1GHz.
2. The resolution bandwidth and video bandwidth of test receiver/spectrum analyzer is 1 MHz for Peak detection at frequency above 1GHz.
3. The resolution bandwidth of test receiver/spectrum analyzer is 1 MHz and the video bandwidth is 10 Hz for Average detection (AV) at frequency above 1GHz.

### 4.2.4 DEVIATION FROM TEST STANDARD

No deviation

#### 4.2.5 TEST SETUP

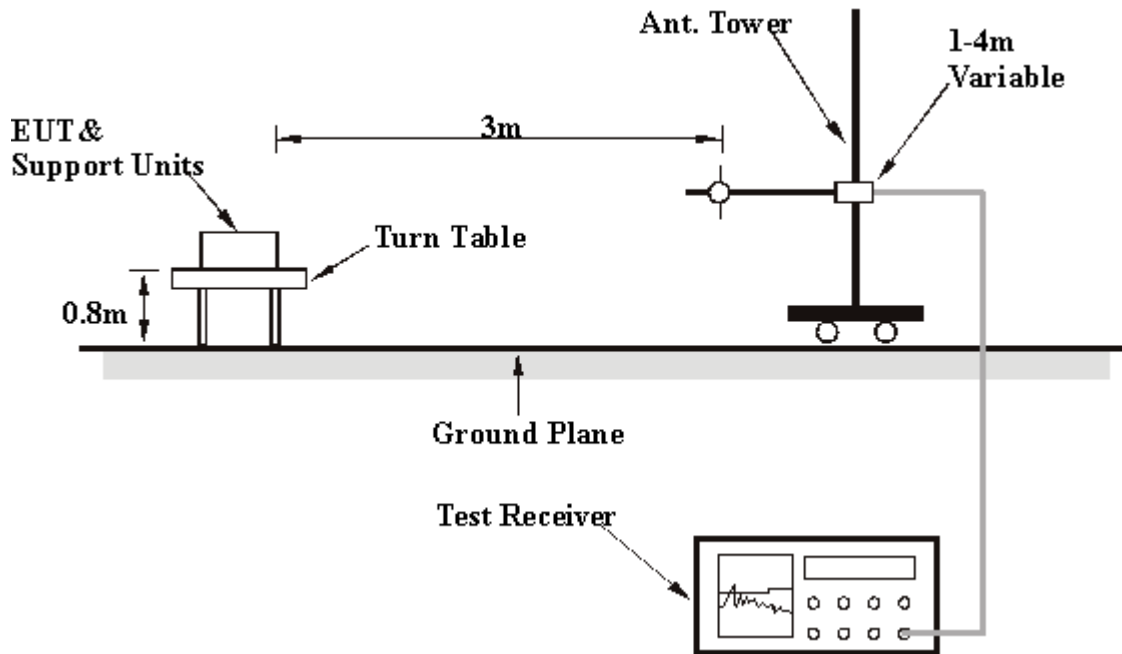

For the actual test configuration, please refer to the related item – Photographs of the Test Configuration.

#### 4.2.6 EUT OPERATING CONDITIONS

Same as 4.1.6



4.2.7. TEST RESULTS

<b>EUT</b>	Wireless 802.11g MiniPCI Card	<b>MODEL</b>	WM1210
<b>CHANNEL</b>	11	<b>FREQUENCY RANGE</b>	Below 1000MHz
<b>INPUT POWER (SYSTEM)</b>	120Vac, 60Hz	<b>DETECTOR FUNCTION</b>	Quasi-Peak
<b>ENVIRONMENTAL CONDITIONS</b>	23deg. C, 64%RH, 991hPa	<b>TESTED BY</b>	Gary Chang

<b>ANTENNA POLARITY &amp; TEST DISTANCE: HORIZONTAL AT 3 M</b>								
No.	Freq. (MHz)	Emission Level (dBuV/m)	Limit (dBuV/m)	Margin (dB)	Antenna Height (m)	Table Angle (Degree)	Raw Value (dBuV)	Correction Factor (dB/m)
1	70.82	31.49 QP	40.00	-8.51	4.00 H	82	18.73	12.77
2	166.68	40.40 QP	43.50	-3.10	1.62 H	360	26.25	14.15
3	199.12	40.90 QP	43.50	-2.60	1.00 H	139	29.37	11.53
4	278.82	34.93 QP	46.00	-11.07	1.00 H	346	20.50	14.43
5	393.51	34.29 QP	46.00	-11.71	3.00 H	262	17.48	16.82
6	718.14	36.34 QP	46.00	-9.66	3.50 H	166	13.40	22.93
7	889.20	35.38 QP	46.00	-10.62	3.00 H	103	10.36	25.03

- REMARKS:**
1. Emission level(dBuV/m)=Raw Value(dBuV) + Correction Factor(dB/m)
  2. Correction Factor(dB/m) = Antenna Factor (dB/m) + Cable Factor (dB)
  3. The other emission levels were very low against the limit.
  4. Margin value = Emission level – Limit value.



<b>EUT</b>	Wireless 802.11g MiniPCI Card	<b>MODEL</b>	WM1210
<b>CHANNEL</b>	11	<b>FREQUENCY RANGE</b>	Below 1000MHz
<b>INPUT POWER (SYSTEM)</b>	120Vac, 60Hz	<b>DETECTOR FUNCTION</b>	Quasi-Peak
<b>ENVIRONMENTAL CONDITIONS</b>	23deg. C, 64%RH, 991hPa	<b>TESTED BY</b>	Gary Chang

<b>ANTENNA POLARITY &amp; TEST DISTANCE: VERTICAL AT 3 M</b>								
No.	Freq. (MHz)	Emission Level (dBuV/m)	Limit (dBuV/m)	Margin (dB)	Antenna Height (m)	Table Angle (Degree)	Raw Value (dBuV)	Correction Factor (dB/m)
1	31.94	36.43 QP	40.00	-3.57	1.00 V	313	21.92	14.50
2	66.93	35.30 QP	40.00	-4.70	3.50 V	154	22.04	13.27
3	133.30	27.94 QP	43.50	-15.56	2.00 V	104	14.24	13.69
4	171.90	35.28 QP	43.50	-8.22	2.00 V	160	21.58	13.69
5	200.07	32.73 QP	43.50	-10.77	2.00 V	327	21.26	11.46
6	325.47	35.13 QP	46.00	-10.87	1.50 V	145	19.79	15.34
7	455.71	37.05 QP	46.00	-8.95	1.00 V	112	18.87	18.18
8	494.59	36.31 QP	46.00	-9.69	3.00 V	133	17.67	18.65
9	603.45	35.44 QP	46.00	-10.56	2.00 V	121	14.15	21.30
10	786.17	34.93 QP	46.00	-11.07	2.00 V	130	11.18	23.75
11	846.43	39.14 QP	46.00	-6.86	2.00 V	130	14.92	24.22
12	904.75	35.97 QP	46.00	-10.03	2.50 V	148	10.67	25.30

- REMARKS:**
1. Emission level(dBuV/m)=Raw Value(dBuV) + Correction Factor(dB/m)
  2. Correction Factor(dB/m) = Antenna Factor (dB/m) + Cable Factor (dB)
  3. The other emission levels were very low against the limit.
  4. Margin value = Emission level – Limit value.



<b>EUT</b>	Wireless 802.11g MiniPCI Card	<b>MODEL</b>	WM1210
<b>CHANNEL</b>	1	<b>FREQUENCY RANGE</b>	1 ~ 25GHz
<b>MODULATION MODE</b>	CCK	<b>INPUT POWER (SYSTEM)</b>	120Vac, 60Hz
<b>ENVIRONMENTAL CONDITIONS</b>	20deg. C, 76%RH, 991hPa	<b>DETECTOR FUNCTION</b>	Peak (PK) Average (AV)
<b>TESTED BY:</b> Jun Wu			

<b>ANTENNA POLARITY &amp; TEST DISTANCE: HORIZONTAL AT 3 M</b>								
No.	Freq. (MHz)	Emission Level (dBuV/m)	Limit (dBuV/m)	Margin (dB)	Antenna Height (m)	Table Angle (Degree)	Raw Value (dBuV)	Correction Factor (dB/m)
1	2390.00	49.70 PK	74.00	-24.30	1.82 H	126	17.87	31.84
1	2390.00	41.59 AV	54.00	-12.41	1.82 H	126	9.76	31.84
2	*2412.00	103.93 PK			1.82 H	126	72.00	31.93
2	*2412.00	95.82 AV			1.82 H	126	63.89	31.93
3	4824.00	49.16 PK	74.00	-24.84	1.04 H	228	11.59	37.58
3	4824.00	41.46 AV	54.00	-12.54	1.04 H	228	3.89	37.58
4	7236.00	56.66 PK	74.00	-17.34	1.32 H	243	12.71	43.95
4	7236.00	45.35 AV	54.00	-8.65	1.32 H	243	1.40	43.95
5	9648.00	57.43 PK	74.00	-16.57	1.34 H	252	8.29	49.14
5	9648.00	46.32 AV	54.00	-7.68	1.34 H	252	-2.82	49.14

<b>ANTENNA POLARITY &amp; TEST DISTANCE: VERTICAL AT 3 M</b>								
No.	Freq. (MHz)	Emission Level (DbuV/m)	Limit (dBuV/m)	Margin (dB)	Antenna Height (m)	Table Angle (Degree)	Raw Value (dBuV)	Correction Factor (dB/m)
1	2390.00	62.17 PK	74.00	-11.83	1.14 V	211	30.34	31.84
1	2390.00	50.31 AV	54.00	-3.69	1.14 V	211	18.48	31.84
2	*2412.00	112.48 PK			1.14 V	211	80.55	31.93
2	*2412.00	104.54 AV			1.14 V	211	72.61	31.93
3	4824.00	54.37 PK	74.00	-19.63	1.11 V	2	16.80	37.58
3	4824.00	44.84 AV	54.00	-9.16	1.11 V	2	7.27	37.58
4	7236.00	60.36 PK	74.00	-13.64	1.60 V	98	16.41	43.95
4	7236.00	49.78 AV	54.00	-4.22	1.60 V	98	5.83	43.95
5	9648.00	59.06 PK	74.00	-14.94	1.54 V	280	9.92	49.14
5	9648.00	48.12 AV	54.00	-5.88	1.54 V	280	-1.02	49.14

- REMARKS:**
1. Emission level (dBuV/m)=Raw Value (dBuV) + Correction Factor (dB)
  2. Correction Factor (dB/m) = Antenna Factor (dB/m) + Cable Factor (dB)
  3. The other emission levels were very low against the limit.
  4. Margin value = Emission level – Limit value.
  5. “ \* “: Fundamental frequency.





<b>EUT</b>	Wireless 802.11g MiniPCI Card	<b>MODEL</b>	WM1210
<b>CHANNEL</b>	6	<b>FREQUENCY RANGE</b>	1 ~ 25GHz
<b>MODULATION MODE</b>	CCK	<b>INPUT POWER (SYSTEM)</b>	120Vac, 60Hz
<b>ENVIRONMENTAL CONDITIONS</b>	20deg. C, 76%RH, 991hPa	<b>DETECTOR FUNCTION</b>	Peak (PK) Average (AV)
<b>TESTED BY:</b> Jun Wu			

**ANTENNA POLARITY & TEST DISTANCE: HORIZONTAL AT 3 M**

No.	Freq. (MHz)	Emission Level (dBuV/m)	Limit (dBuV/m)	Margin (dB)	Antenna Height (m)	Table Angle (Degree)	Raw Value (dBuV)	Correction Factor (dB/m)
1	*2437.00	105.28 PK			1.38 H	157	73.21	32.07
1	*2437.00	97.10 AV			1.38 H	157	65.03	32.07
2	4874.00	49.97 PK	74.00	-24.03	1.18 H	287	12.29	37.68
3	7312.00	57.20 PK	74.00	-16.80	1.23 H	69	13.14	44.06
3	7312.00	44.48 AV	54.00	-9.52	1.23 H	69	0.42	44.06

**ANTENNA POLARITY & TEST DISTANCE: VERTICAL AT 3 M**

No.	Freq. (MHz)	Emission Level (dBuV/m)	Limit (dBuV/m)	Margin (dB)	Antenna Height (m)	Table Angle (Degree)	Raw Value (dBuV)	Correction Factor (dB/m)
1	*2437.00	111.65 PK			1.34 V	79	79.58	32.07
1	*2437.00	102.36 AV			1.34 V	79	70.29	32.07
2	4874.00	52.66 PK	74.00	-21.34	1.15 V	273	14.98	37.68
2	4874.00	38.85 AV	54.00	-15.15	1.15 V	273	1.17	37.68
3	7309.00	59.26 PK	74.00	-14.74	1.12 V	88	15.21	44.05
3	7309.00	47.13 AV	54.00	-6.87	1.12 V	88	3.08	44.05
4	9747.00	54.39 PK	74.00	-19.61	1.46 V	214	4.80	49.59
4	9747.00	51.19 AV	54.00	-2.81	1.46 V	214	1.60	49.59

- REMARKS:**
1. Emission level (dBuV/m)=Raw Value (dBuV) + Correction Factor (dB)
  2. Correction Factor (dB/m) = Antenna Factor (dB/m) + Cable Factor (dB)
  3. The other emission levels were very low against the limit.
  4. Margin value = Emission level – Limit value.
  5. “ \* “: Fundamental frequency.



<b>EUT</b>	Wireless 802.11g MiniPCI Card	<b>MODEL</b>	WM1210
<b>CHANNEL</b>	11	<b>FREQUENCY RANGE</b>	1 ~ 25GHz
<b>MODULATION MODE</b>	CCK	<b>INPUT POWER (SYSTEM)</b>	120Vac, 60Hz
<b>ENVIRONMENTAL CONDITIONS</b>	20deg. C, 76%RH, 991hPa	<b>DETECTOR FUNCTION</b>	Peak (PK) Average (AV)
<b>TESTED BY:</b> Jun Wu			

<b>ANTENNA POLARITY &amp; TEST DISTANCE: HORIZONTAL AT 3 M</b>								
No.	Freq. (MHz)	Emission Level (dBuV/m)	Limit (dBuV/m)	Margin (dB)	Antenna Height (m)	Table Angle (Degree)	Raw Value (dBuV)	Correction Factor (dB/m)
1	*2462.00	101.13 PK			1.60 H	158	68.93	32.20
1	*2462.00	93.18 AV			1.60 H	158	60.98	32.20
2	2483.50	47.53 PK	74.00	-26.47	1.60 H	158	15.22	32.31
2	2483.50	39.58 AV	54.00	-14.42	1.60 H	158	7.27	32.31
3	4924.00	51.30 PK	74.00	-22.70	1.46 H	180	13.56	37.74
3	4924.00	45.12 AV	54.00	-8.88	1.46 H	180	7.38	37.74
4	7386.00	56.84 PK	74.00	-17.16	1.56 H	83	12.46	44.38
4	7386.00	44.74 AV	54.00	-9.26	1.56 H	83	0.36	44.38
5	9848.00	58.63 PK	74.00	-15.37	1.35 H	235	8.38	50.25
5	9848.00	47.32 AV	54.00	-6.68	1.35 H	235	-2.93	50.25

<b>ANTENNA POLARITY &amp; TEST DISTANCE: VERTICAL AT 3 M</b>								
No.	Freq. (MHz)	Emission Level (dBuV/m)	Limit (dBuV/m)	Margin (dB)	Antenna Height (m)	Table Angle (Degree)	Raw Value (dBuV)	Correction Factor (dB/m)
1	*2462.00	112.16 PK			1.10 V	217	79.96	32.20
1	*2462.00	104.23 AV			1.10 V	217	72.03	32.20
2	2483.50	58.56 PK	74.00	-15.44	1.10 V	217	26.25	32.31
2	2483.50	50.63 AV	54.00	-3.37	1.10 V	217	18.32	32.31
3	4924.00	55.48 PK	74.00	-18.52	1.10 V	330	17.74	37.74
3	4924.00	44.62 AV	54.00	-9.38	1.10 V	330	6.88	37.74
4	7386.00	60.81 PK	74.00	-13.19	1.55 V	98	16.43	44.38
4	7386.00	51.45 AV	54.00	-2.55	1.55 V	98	7.07	44.38
5	9848.00	61.19 PK	74.00	-12.81	1.50 V	180	10.94	50.25
5	9848.00	49.23 AV	54.00	-4.77	1.50 V	180	-1.02	50.25

- REMARKS:**
1. Emission level (dBuV/m)=Raw Value (dBuV) + Correction Factor (dB)
  2. Correction Factor (dB/m) = Antenna Factor (dB/m) + Cable Factor (dB)
  3. The other emission levels were very low against the limit.
  4. Margin value = Emission level – Limit value.
  5. “ \* “: Fundamental frequency.



<b>EUT</b>	Wireless 802.11g MiniPCI Card	<b>MODEL</b>	WM1210
<b>CHANNEL</b>	1	<b>FREQUENCY RANGE</b>	1 ~ 25GHz
<b>MODULATION MODE</b>	OFDM	<b>INPUT POWER (SYSTEM)</b>	120Vac, 60Hz
<b>ENVIRONMENTAL CONDITIONS</b>	23deg. C, 70%RH, 991hPa	<b>DETECTOR FUNCTION</b>	Peak (PK) Average (AV)
<b>TESTED BY:</b> Martin Lee			

**ANTENNA POLARITY & TEST DISTANCE: HORIZONTAL AT 3 M**

No.	Freq. (MHz)	Emission Level (dBuV/m)	Limit (dBuV/m)	Margin (dB)	Antenna Height (m)	Table Angle (Degree)	Raw Value (dBuV)	Correction Factor (dB/m)
1	2390.00	42.54 PK	74.00	-31.46	1.58 H	360	11.74	30.80
2	2390.00	33.20 AV	54.00	-20.80	1.58 H	360	2.4	30.80
2	2412.00	96.37 PK	74.00	22.37	1.58 H	360	65.67	30.70
2	2412.00	87.03 AV	54.00	33.03	1.58 H	360	56.33	30.70
3	4824.00	49.42 PK	74.00	-24.58	1.00 H	0	12.90	36.52
3	4824.00	40.59 AV	54.00	-13.41	1.00 H	0	4.07	36.52
4	9648.00	54.44 PK	74.00	-19.56	1.52 H	29	10.16	44.28
4	9648.00	43.11 AV	54.00	-10.89	1.52 H	29	-1.17	44.28

**ANTENNA POLARITY & TEST DISTANCE: VERTICAL AT 3 M**

No.	Freq. (MHz)	Emission Level (DbuV/m)	Limit (dBuV/m)	Margin (dB)	Antenna Height (m)	Table Angle (Degree)	Raw Value (dBuV)	Correction Factor (dB/m)
1	2390.00	53.54 PK	74.00	-20.46	1.48 V	240	22.74	30.80
1	2390.00	43.87 AV	54.00	-10.13	1.48 V	240	13.07	30.80
2	*2412.00	107.37 PK			1.48 V	240	76.67	30.70
2	*2412.00	97.70 AV			1.48 V	240	67.00	30.70
3	4824.00	51.92 PK	74.00	-22.08	1.55 V	17	15.40	36.52
3	4824.00	47.42 AV	54.00	-6.58	1.55 V	17	10.90	36.52
4	9648.00	56.29 PK	74.00	-17.71	1.56 V	179	12.01	44.28
4	9648.00	45.27 AV	54.00	-8.73	1.56 V	179	0.99	44.28

- REMARKS:**
1. Emission level (dBuV/m)=Raw Value (dBuV) + Correction Factor (dB)
  2. Correction Factor (dB/m) = Antenna Factor (dB/m) + Cable Factor (dB)
  3. The other emission levels were very low against the limit.
  4. Margin value = Emission level – Limit value.
  5. “ \* ”: Fundamental frequency.



<b>EUT</b>	Wireless 802.11g MiniPCI Card	<b>MODEL</b>	WM1210
<b>CHANNEL</b>	6	<b>FREQUENCY RANGE</b>	1 ~ 25GHz
<b>MODULATION MODE</b>	OFDM	<b>INPUT POWER (SYSTEM)</b>	120Vac, 60Hz
<b>ENVIRONMENTAL CONDITIONS</b>	23deg. C, 70%RH, 991hPa	<b>DETECTOR FUNCTION</b>	Peak (PK) Average (AV)
<b>TESTED BY:</b> Martin Lee			

<b>ANTENNA POLARITY &amp; TEST DISTANCE: HORIZONTAL AT 3 M</b>								
No.	Freq. (MHz)	Emission Level (dBuV/m)	Limit (dBuV/m)	Margin (dB)	Antenna Height (m)	Table Angle (Degree)	Raw Value (dBuV)	Correction Factor (dB/m)
1	*2437.00	99.70 PK			1.48 H	230	68.98	30.72
1	*2437.00	89.95 AV			1.48 H	230	59.23	30.72
2	4874.00	51.63 PK	74.00	-22.37	1.40 H	126	14.92	36.71
2	4874.00	45.44 AV	54.00	-8.56	1.40 H	126	8.73	36.71
3	9748.00	56.54 PK	74.00	-17.46	1.51 H	76	12.31	44.23
3	9748.00	46.73 AV	54.00	-7.27	1.51 H	76	2.50	44.23

<b>ANTENNA POLARITY &amp; TEST DISTANCE: VERTICAL AT 3 M</b>								
No.	Freq. (MHz)	Emission Level (dBuV/m)	Limit (dBuV/m)	Margin (dB)	Antenna Height (m)	Table Angle (Degree)	Raw Value (dBuV)	Correction Factor (dB/m)
1	*2437.00	109.39 PK			1.50 V	239	78.67	30.72
1	*2437.00	100.05 AV			1.50 V	239	69.33	30.72
2	4874.00	54.44 PK	74.00	-19.56	1.57 V	18	17.73	36.71
2	4874.00	49.44 AV	54.00	-4.56	1.57 V	18	12.73	36.71
3	9748.00	56.20 PK	74.00	-17.80	1.39 V	195	11.97	44.23
3	9748.00	46.99 AV	54.00	-7.01	1.39 V	195	2.76	44.23

- REMARKS:**
1. Emission level (dBuV/m)=Raw Value (dBuV) + Correction Factor (dB)
  2. Correction Factor (dB/m) = Antenna Factor (dB/m) + Cable Factor (dB)
  3. The other emission levels were very low against the limit.
  4. Margin value = Emission level – Limit value.
  5. “ \* “: Fundamental frequency.



<b>EUT</b>	Wireless 802.11g MiniPCI Card	<b>MODEL</b>	WM1210
<b>CHANNEL</b>	11	<b>FREQUENCY RANGE</b>	1 ~ 25GHz
<b>MODULATION MODE</b>	OFDM	<b>INPUT POWER (SYSTEM)</b>	120Vac, 60Hz
<b>ENVIRONMENTAL CONDITIONS</b>	23deg. C, 70%RH, 991hPa	<b>DETECTOR FUNCTION</b>	Peak (PK) Average (AV)
<b>TESTED BY:</b> Martin Lee			

<b>ANTENNA POLARITY &amp; TEST DISTANCE: HORIZONTAL AT 3 M</b>								
No.	Freq. (MHz)	Emission Level (dBuV/m)	Limit (dBuV/m)	Margin (dB)	Antenna Height (m)	Table Angle (Degree)	Raw Value (dBuV)	Correction Factor (dB/m)
1	*2462.00	96.74 PK			1.00 H	255	66.00	30.74
1	*2462.00	87.64 AV			1.00 H	255	56.90	30.74
2	2483.50	45.40 PK	74.00	-28.60	1.00 H	255	14.64	30.76
3	4924.00	49.80 PK	74.00	-24.20	1.49 H	250	12.89	36.90
4	9848.00	55.51 PK	74.00	-18.49	1.44 H	1	11.32	44.19
4	9848.00	44.04 AV	54.00	-9.96	1.44 H	1	-0.15	44.19

<b>ANTENNA POLARITY &amp; TEST DISTANCE: VERTICAL AT 3 M</b>								
No.	Freq. (MHz)	Emission Level (dBuV/m)	Limit (dBuV/m)	Margin (dB)	Antenna Height (m)	Table Angle (Degree)	Raw Value (dBuV)	Correction Factor (dB/m)
1	*2462.00	106.38 PK			1.04 V	49	75.64	30.74
1	*2462.00	96.35 AV			1.04 V	49	65.61	30.74
2	2483.50	55.04 PK	74.00	-18.96	1.04 V	49	24.28	30.76
2	2483.50	45.01 AV	54.00	-8.99	1.04 V	49	14.25	30.76
3	4924.00	52.80 PK	74.00	-21.20	1.40 V	34	15.89	36.90
3	4924.00	47.77 AV	54.00	-6.23	1.40 V	34	10.86	36.90
4	9848.00	57.49 PK	74.00	-16.51	1.57 V	354	13.30	44.19
4	9848.00	48.70 AV	54.00	-5.30	1.57 V	354	4.51	44.19

- REMARKS:**
1. Emission level (dBuV/m)=Raw Value (dBuV) + Correction Factor (dB)
  2. Correction Factor (dB/m) = Antenna Factor (dB/m) + Cable Factor (dB)
  3. The other emission levels were very low against the limit.
  4. Margin value = Emission level – Limit value.
  5. “ \* “: Fundamental frequency.



**4.3 6dB BANDWIDTH MEASUREMENT**

4.3.1 LIMITS OF 6dB BANDWIDTH MEASUREMENT

The minimum of 6dB Bandwidth Measurement is 0.5 MHz.

4.3.2 TEST INSTRUMENTS

Description & Manufacturer	Model No.	Serial No.	Calibrated Until
SPECTRUM ANALYZER	FSEK30	100049	Aug. 12, 2004

**NOTE:** The calibration interval of the above test instruments is 12 months and the calibrations are traceable to NML/ROC and NIST/USA.

4.3.3 TEST PROCEDURE

The transmitter output was connected to the spectrum analyzer through an attenuator. The bandwidth of the fundamental frequency was measured by spectrum analyzer with 100kHz RBW and 100kHz VBW. The 6dB bandwidth is defined as the total spectrum the power of which is higher than peak power minus 6dB.

4.3.4 DEVIATION FROM TEST STANDARD

No deviation

4.3.5 TEST SETUP

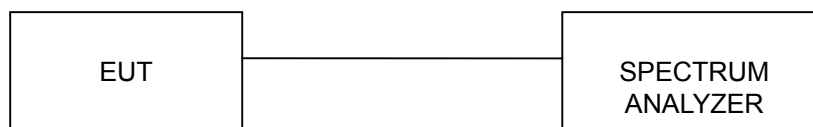

For the actual test configuration, please refer to the related Item – Photographs of the Test Configuration.

4.3.6 EUT OPERATING CONDITIONS

The software provided by client to enable the EUT under transmission condition continuously at lowest, middle and highest channel frequencies individually.



## 4.3.7 TEST RESULTS

<b>EUT</b>	Wireless 802.11g MiniPCI Card	<b>MODEL</b>	WM1210
<b>INPUT POWER (SYSTEM)</b>	120Vac, 60Hz	<b>ENVIRONMENTAL CONDITIONS</b>	20deg. C, 75%RH, 991hPa
<b>MODULATION MODE</b>	CCK	<b>TESTED BY</b>	Steven Lu

<b>CHANNEL</b>	<b>CHANNEL FREQUENCY (MHz)</b>	<b>6dB BANDWIDTH (MHz)</b>	<b>MINIMUM LIMIT (MHz)</b>	<b>PASS/FAIL</b>
1	2412	11.52	0.5	PASS
6	2437	11.56	0.5	PASS
11	2462	11.52	0.5	PASS



CH1

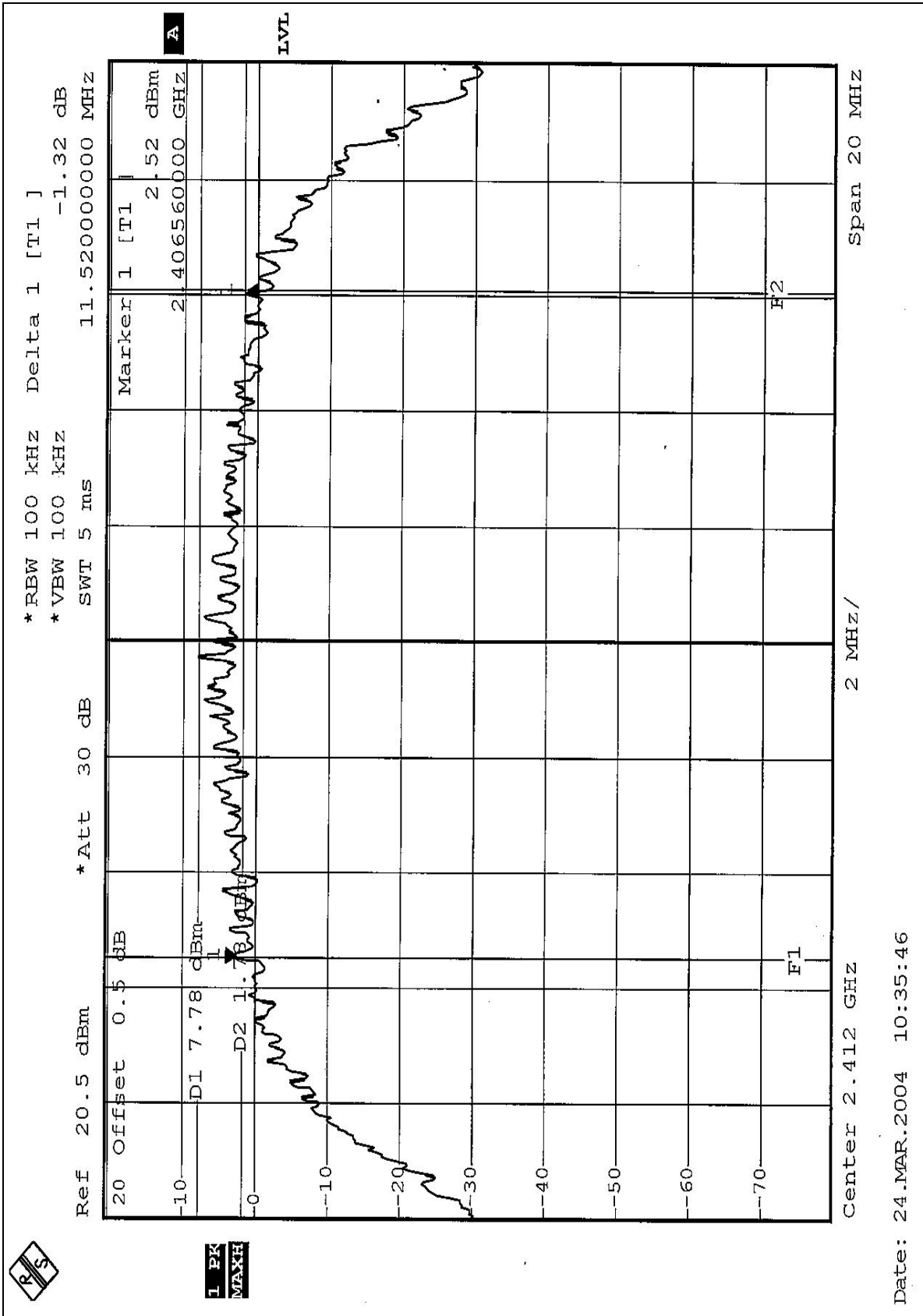





CH6

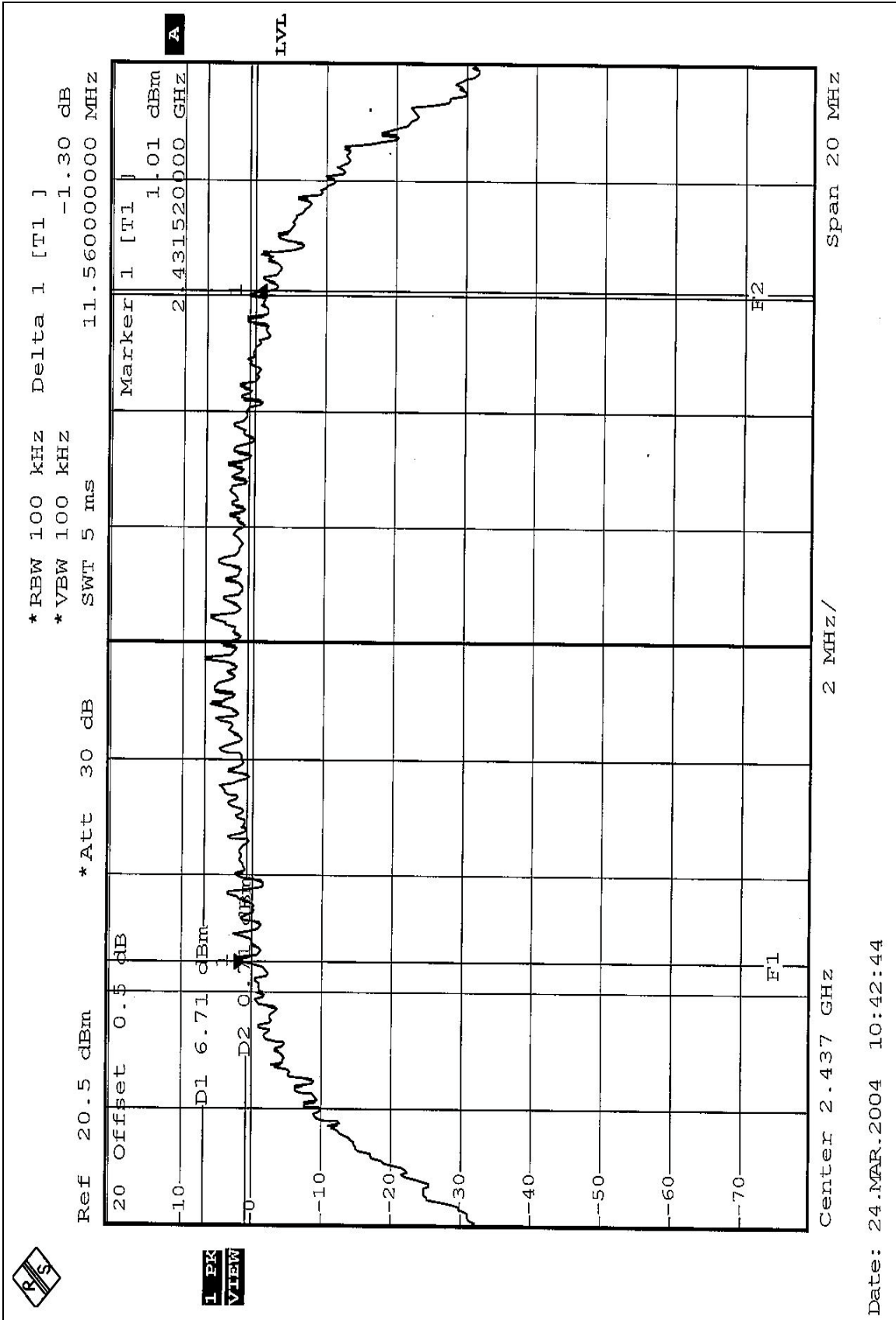



CH11

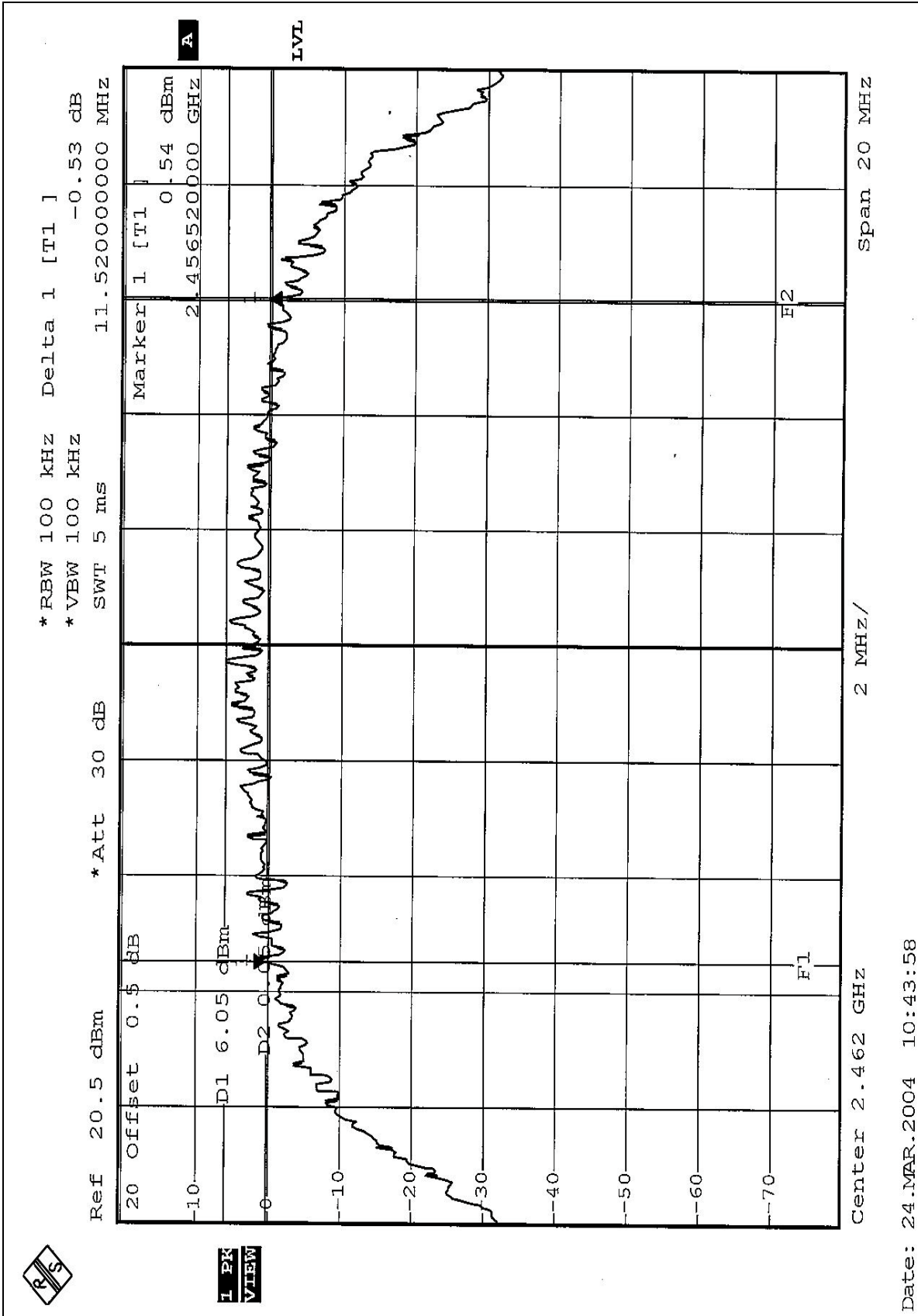



<b>EUT</b>	Wireless 802.11g MiniPCI Card	<b>MODEL</b>	WM1210
<b>INPUT POWER (SYSTEM)</b>	120Vac, 60Hz	<b>ENVIRONMENTAL CONDITIONS</b>	20deg. C, 73%RH, 991hPa
<b>MODULATION MODE</b>	OFDM	<b>TESTED BY</b>	Steven Lu

<b>CHANNEL</b>	<b>CHANNEL FREQUENCY (MHz)</b>	<b>6dB BANDWIDTH (MHz)</b>	<b>MINIMUM LIMIT (MHz)</b>	<b>PASS/FAIL</b>
1	2412	16.44	0.5	PASS
6	2437	16.48	0.5	PASS
11	2462	16.44	0.5	PASS



CH1

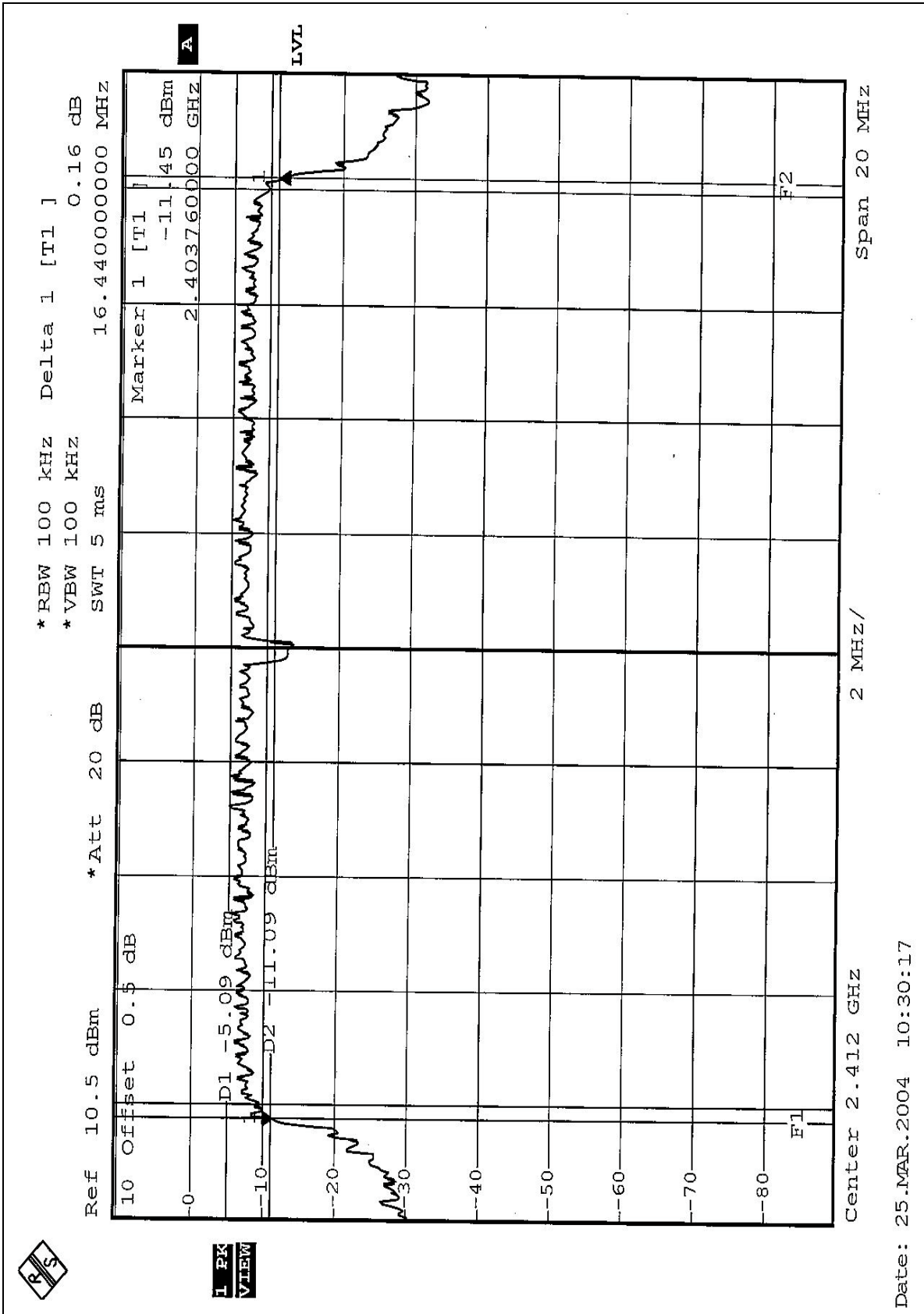



CH6

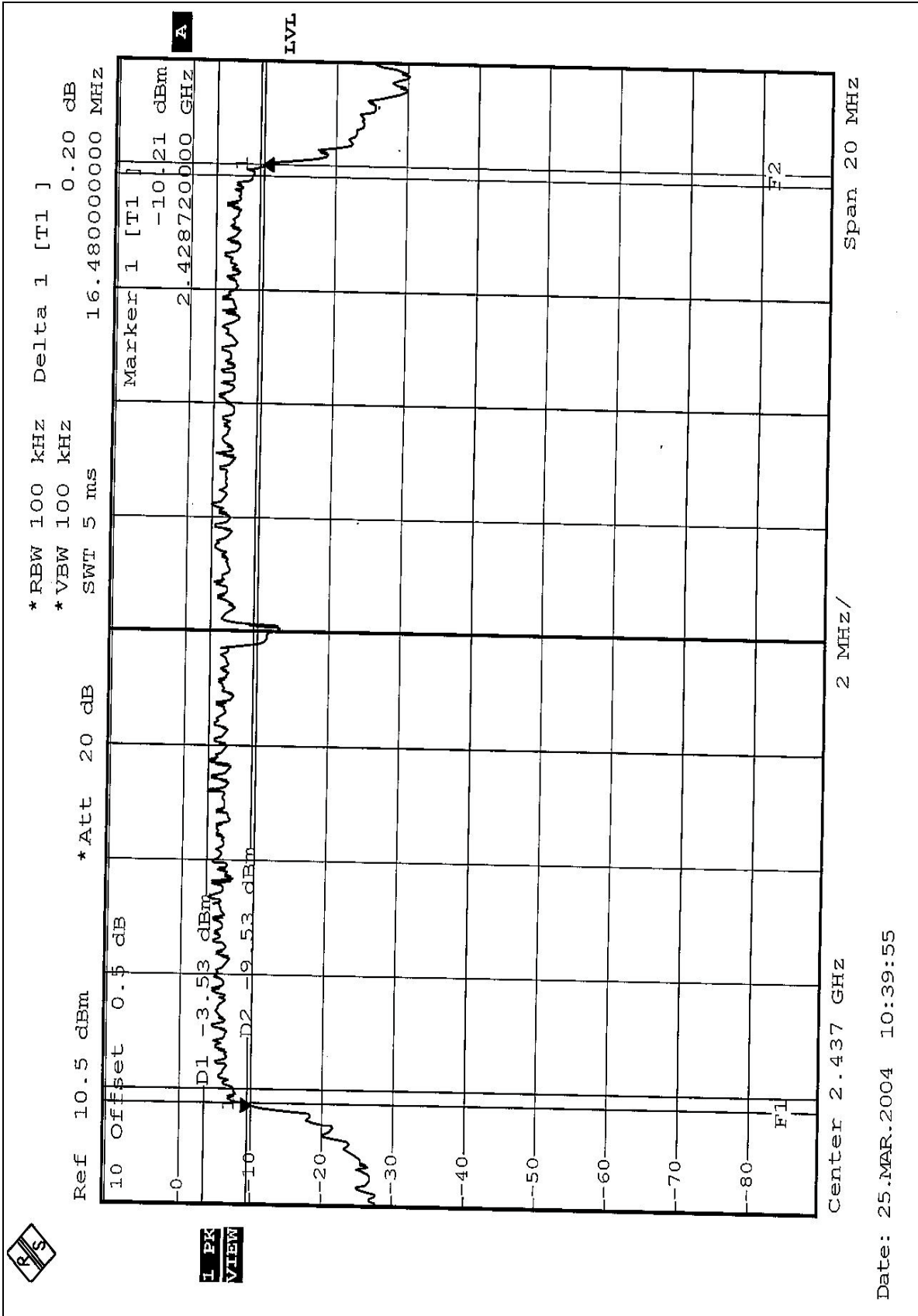

Date: 25.MAR.2004 10:39:55



CH11

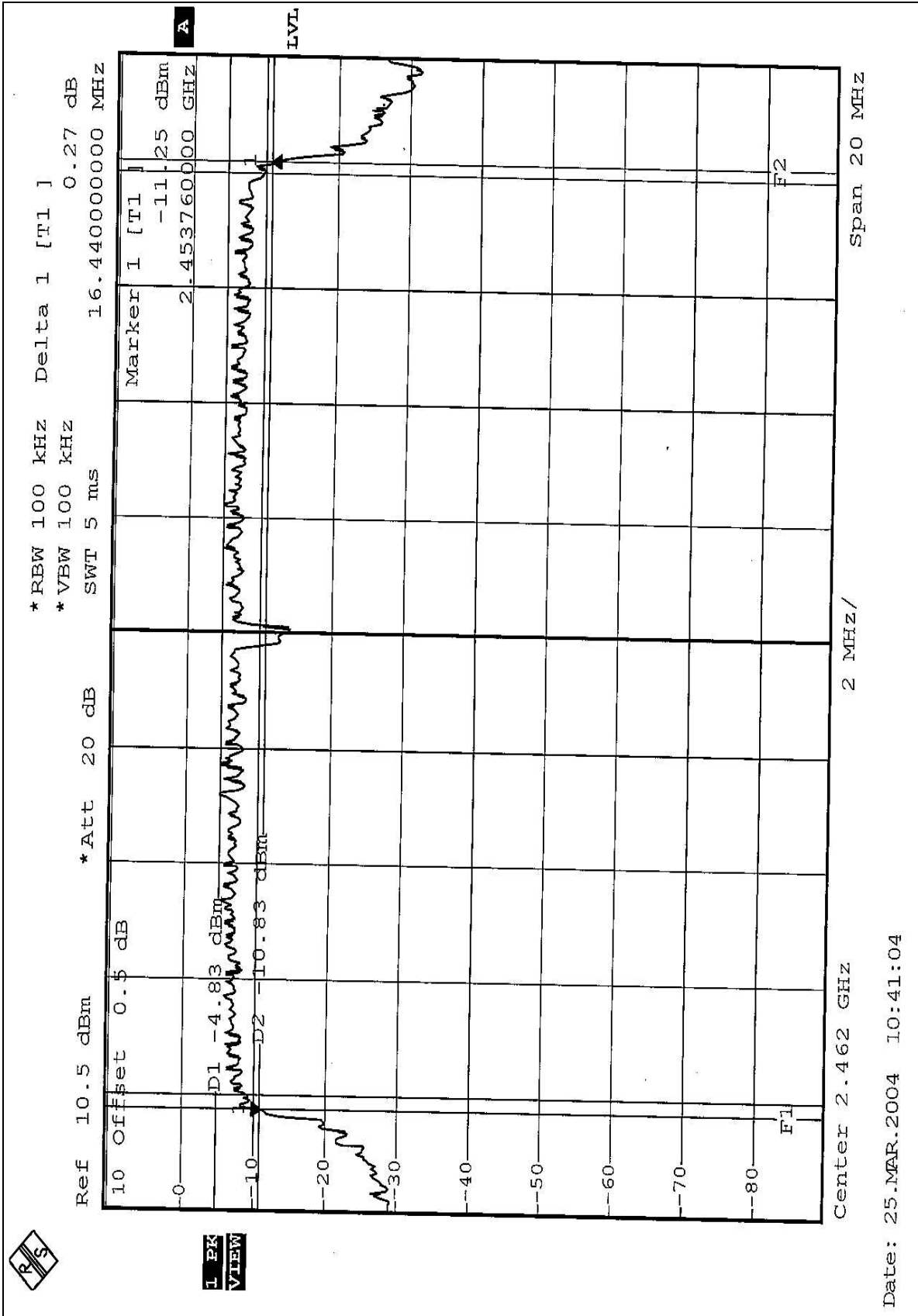



#### 4.4 MAXIMUM PEAK OUTPUT POWER

##### 4.4.1 LIMITS OF MAXIMUM PEAK OUTPUT POWER MEASUREMENT

The Maximum Peak Output Power Measurement is 30dBm.

##### 4.4.2 TEST INSTRUMENTS

Description & Manufacturer	Model No.	Serial No.	Calibrated Until
R&S SPECTRUM ANALYZER	FSEK30	100049	Aug. 12, 2004
R&S SIGNAL GENERATOR	SMP04	100011	May 28, 2004
TEKTRONIX OSCILLOSCOPE	TDS 1012	C019167	Feb. 01, 2005
NARDA DETECTOR	4503A	FSCM99899	NA

**NOTE:**

The calibration interval of the above test instruments is 12 months and the calibrations are traceable to NML/ROC and NIST/USA..



#### 4.4.3 TEST PROCEDURES

1. A detector was used on the output port of the EUT. An oscilloscope was used to read the response of the detector.
2. Replaced the EUT by the signal generator. The center frequency of the S.G was adjusted to the center frequency of the measured channel.
3. Adjusted the power to have the same reading on oscilloscope. Record the power level.

#### 4.4.4 DEVIATION FROM TEST STANDARD

No deviation

#### 4.4.5 TEST SETUP



#### 4.4.6 EUT OPERATING CONDITIONS

Same as Item 4.3.6