

TO: 凱碩科技股份有限公司

SPECIFICATION FOR APPROVAL

DESCRIPTION : 2.4G ANTENNA(WHITE)+1.13(290mm)+CORE+剝皮鍍錫
PART NO : 2AN-CA01WE-019R
慶陸 PART NO : 6602100053-290
DATE : 2009/09/17

PLEASE RETURN TO US ONE COPY OF " SPECIFICATION FOR APPROVAL"
" WITH YOUR APPROVED SIGNATURES

APPROVED SIGNATURES			
			

廣州市慶隆電子塑膠五金有限公司

蘇州慶旺電子科技有限公司

慶宏電子(東莞)有限公司



慶陸工業股份有限公司

KINSUN INDUSTRIES INC.

桃園縣中壢市普忠路 211 巷 20 號

TEL : 886-3-4353551

FAX : 886-3-4353951

[Http://www.kinsun.com](http://www.kinsun.com)

e-mail: jason@kinsun.com

TECHNICAL DATA

Electrical Properties

Frequency Range: 2.4~2.5 GHz

Impedance: 50 Ohm nominal

V.S.W.R : ≤ 2.0

Gain : 2dBi \pm 0.25

Radiation: Omni

Polarization: Vertical

Electrical Wave: Dipole array

Mechanical Properties

Antenna Cover: PLASTIC

Color : WHITE

Operation Temperature:-20°C~+65°C

Storage Temperature:-30°C~+75°C

RoHS COMPLIANT

MECHANICAL

Antenna Cover : PU

Antenna Base : PC UL 94V-0

Color : White

ELECTRICAL

Frequency : 2.4GHz

Cable : Coaxial Cable ϕ 1.13

Core : 4x10x2 mm

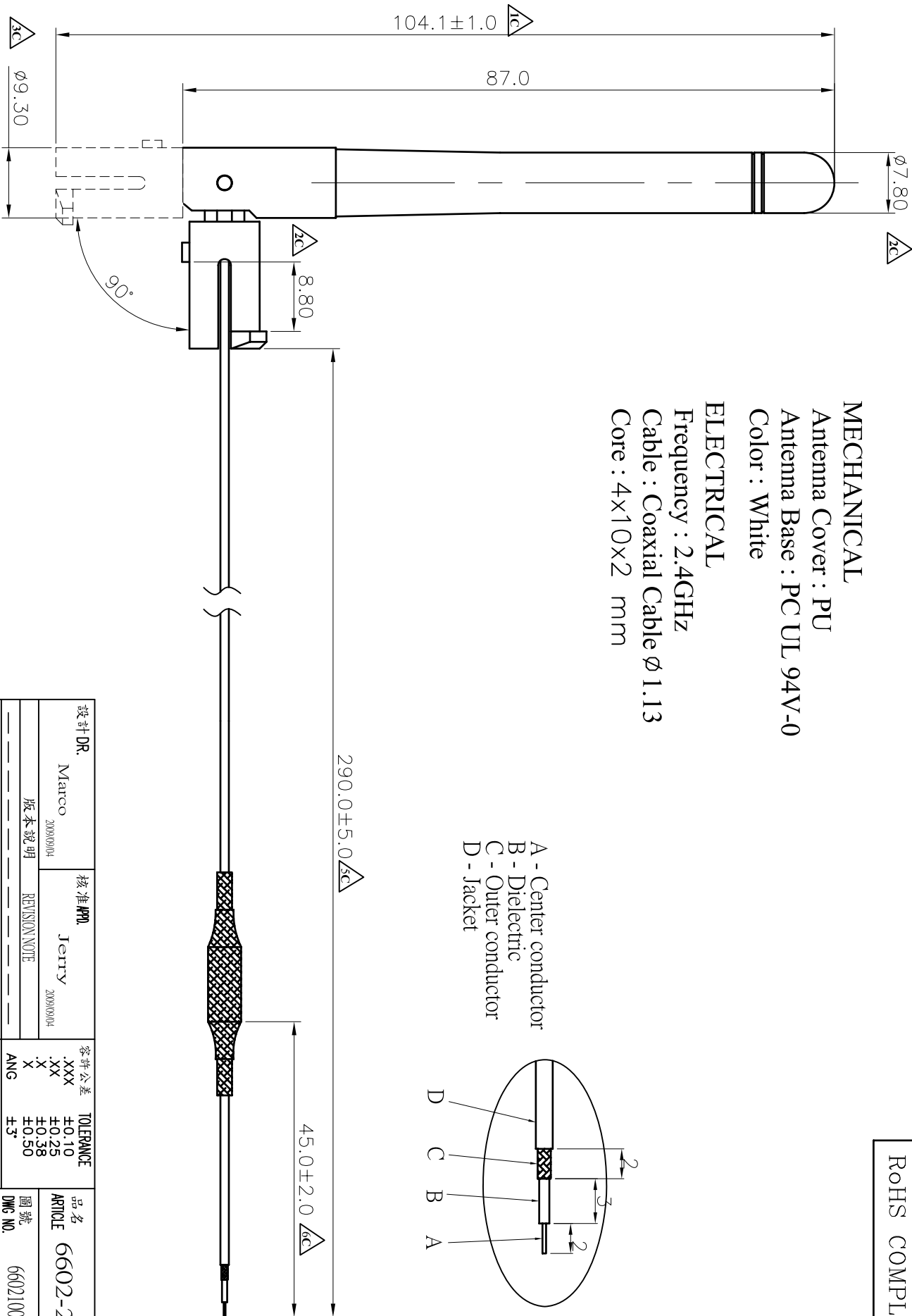

- A - Center conductor
- B - Dielectric
- C - Outer conductor
- D - Jacket

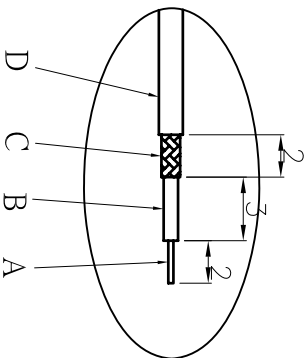

設計 DR.	Marco	核准 APP.	Jerry	容許公差	TOLERANCE	品名	6602-2.4GHZ
	20090904		20090904	.XXX	±0.10	ARTICLE	
版本說明	REVISION NOTE			.XX	±0.25	圖號	6602100053-290
				.X	±0.38	單位 UNIT	mm
				ANG	±3°	比例 SCALE	2/1
						圖號	6602100053-290
						單位 UNIT	mm
						比例 SCALE	2/1
REV. SHEET		REV. SHEET		REV. SHEET		REV. SHEET	
A		A		A		A	

Brand / Model : 6602100053-290

Remark : 2450 MHz

Tested by : Allen Yu

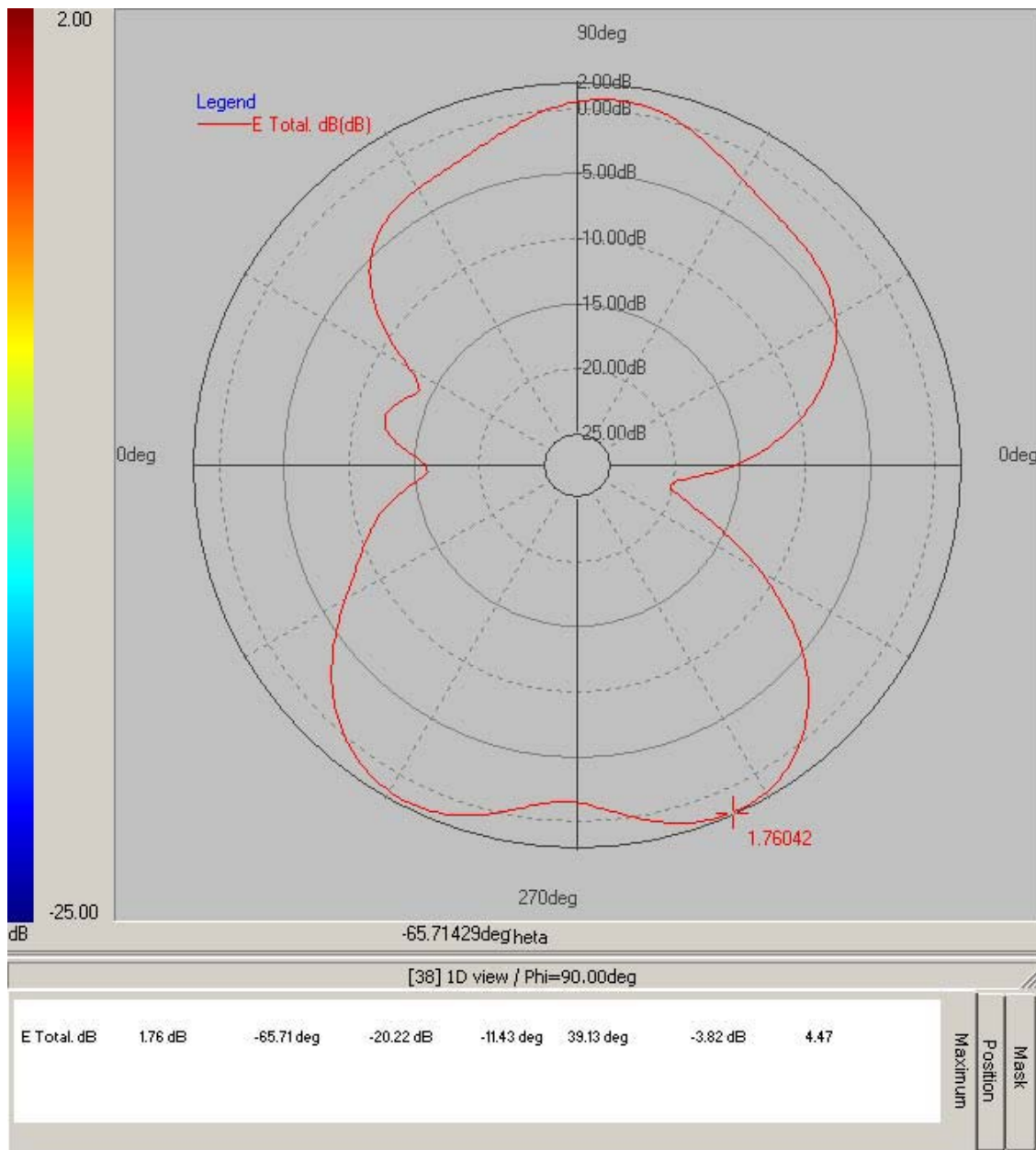

-- : Max. deg

*Unit : dBi

Frequency(MHz) : **2450.00**

Pattern Field : **E plane**

Average Gain(dB) : **-3.82dB**

Maximum Gain(dB) : **1.76dB**

Maximum Gain(degree) : **-65.71**

Minimum Gain(dB) : **-20.22dB**

Minimum Gain(degree) : **-11.43**

Brand / Model : 6602100053-290

Remark : 2450 MHz

Tested by : Allen Yu

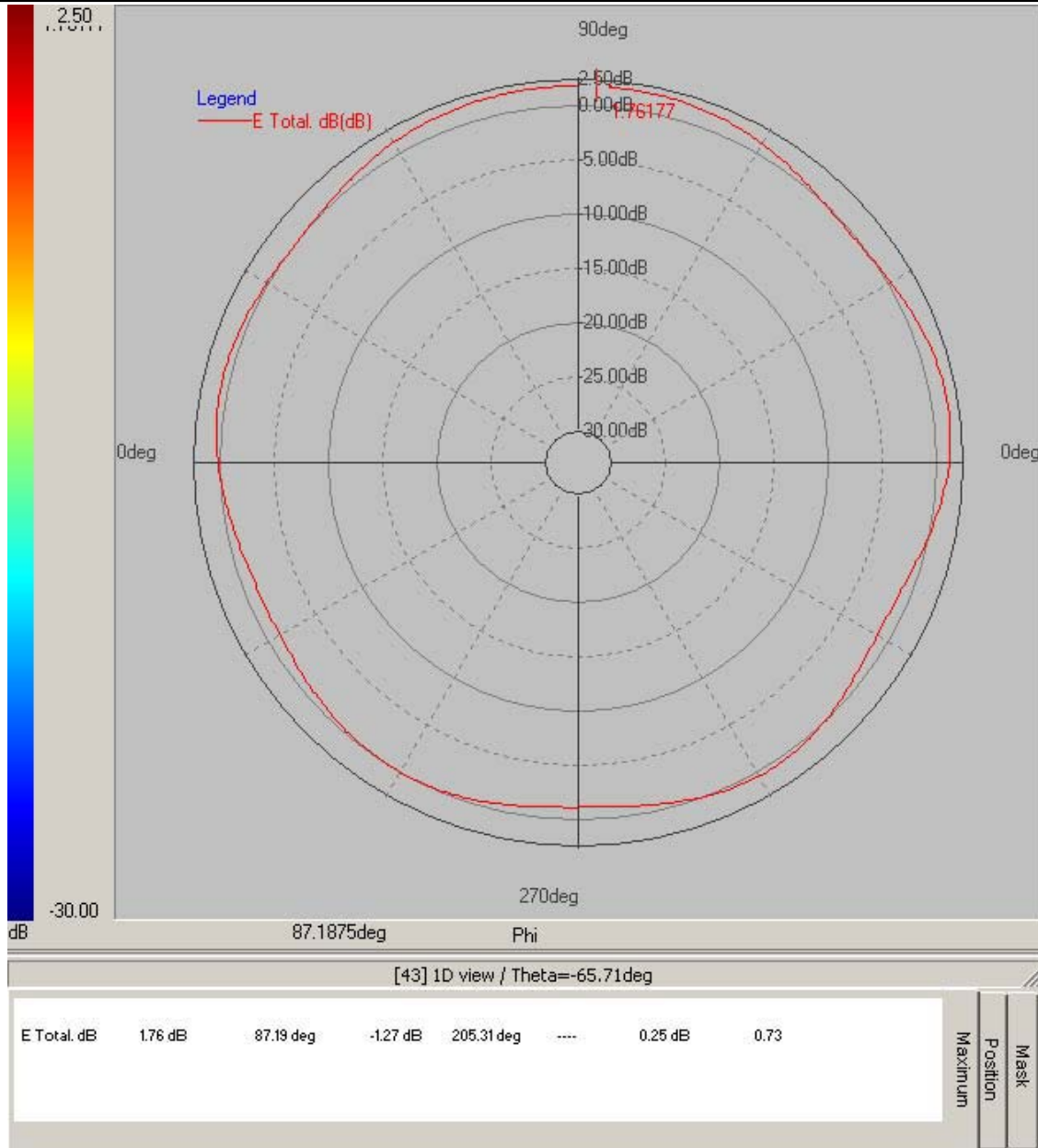

-- : Max. deg

*Unit : dBi

Frequency(MHz) : **2450.00**

Pattern Field : **H plane**

Average Gain(dB) : **0.25dB**

Maximum Gain(dB) : **1.76dB**

Maximum Gain(degree) : **87.19**

Minimum Gain(dB) : **-1.27dB**

Minimum Gain(degree) : **205.31**

Brand / Model : 6602113053-300
 Remark : 2400 MHz – 2500 MHz
 Tested by : Allen Yu

660210053-290

S11

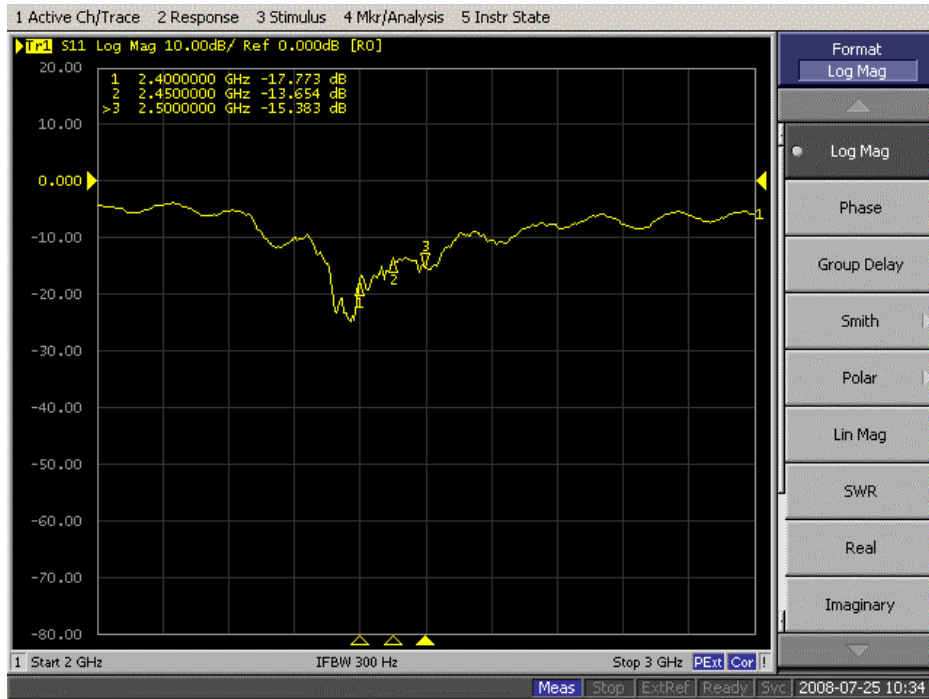

VSWR

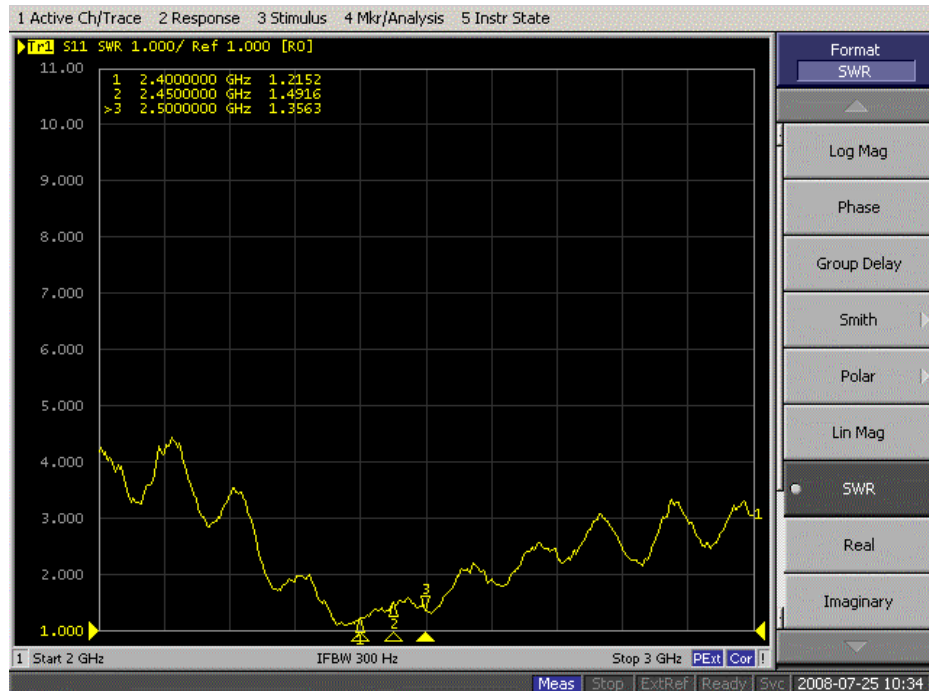

Elastollan[®] S Series

Technical Bulletin

Polyester Type

Elastollan[®] S series of products are polyester-based thermoplastic polyurethanes that exhibit good hydrolytic stability. They also exhibit good oil, fuel and solvent resistance. These products can be injection molded, blow molded and extruded. All grades should be dried before processing. Elastollan[®] products can be stored for up to 1 year in their original container. Containers should be stored in a cool, dry area.

Extrusion grades: S90A

Injection molding grades: S80A to S60D

Physical Properties	Units	ASTM Method	S80A ³	S85A ³	S90A ³	S95A ³	S98A ³	S60D ³
Specific gravity	gr./cm ³	D-792	1.21	1.22	1.23	1.23	1.24	1.25
Hardness	Shore A D	D-2240	80 ± 2	85 ± 2	92 ± 2	96 ± 2	98 ± 2	-
				-	41 ± 2	48 ± 2	54 ± 2	60 ± 2
Tensile strength	MPa psi	D-412	27.5	34	39	42	42	43
			4000	4900	5600	6100	6100	6200
Tensile stress @100 % elongation	MPa psi	D-412	5.5	6.9	11	14	19	22
			800	1000	1550	2000	2700	3200
@300 % elongation	MPa psi		9.6	14	20	26	32	37
			1400	1980	2900	3800	4700	5300
Elongation @brk.	%	D-412	650	690	540	510	425	450
Tensile set @brk.	%	D-412	45	35	55	70	80	110
Tear strength	N/mm lb./in.	D-624 DIE C		104	128	154	185	195
				590	730	875	1050	1150
Abrasion resistance	mg (Loss)	D-1044 ² (Taber)	25	25	25	30	50	50

Test samples were cured 20 hours @ 100 °C before testing.

- NOTE:** ¹ These products can only be ordered in minimum quantities. Please contact your sales representative for details.
² H-18 wheel, 1000 gm weight and 1000 cycles.
³ Products with an N designation do not contain hydrolytic stabilizers. Contact Elastollan Technical Service Rep for further information

Caution: Contact with product dusts from regrinding operations may cause temporary irritation of the eyes and the respiratory tract. Use with local exhaust. Under hot melt processing conditions (170-230 °C), wear personal protective equipment to prevent thermal burns.

First aid: *Eyes*-Flush eyes with flowing water at least 15 minutes. If irritation develops, consult a physician. *Skin*-Skin contact with hot melt may cause thermal burns. Call a physician immediately. *Inhalation*-If vapors generated from the hot melt process are inhaled, move to fresh air. Aid in breathing. If breathing difficulties develop, see a physician immediately.

In case of fire: Use water fog, foam, CO₂, or dry chemical extinguishing media. Firefighters should be equipped with self-contained breathing apparatus and turnout gear.

Disposal: Waste material, unused contents and empty containers must be disposed of in accordance with applicable local, state or federal regulations. Refer to our Material Safety Data Sheet for specific disposal instructions.

In case of chemical emergency: Call CHEMTREC day or night for assistance and information concerning spilled material, fire, exposure and other chemical accidents. 800-424-9300

Attention: This product is sold solely for use by industrial institutions. Refer to our Material Safety Data Sheet regarding safety, usage, applications, hazards, procedures and disposal of this product. Consult your supervisor for additional information.

No warranties of any kind, either express or implied, including warranties of merchantability or fitness for a particular purpose, are made regarding products described or designs, data or information set forth or that the products designs, data or information may be used without infringing the intellectual property rights of others in no case shall the descriptions information, data or designs provided be considered a part of our terms and conditions of sale. Further, you expressly understand and agree that the descriptions, designs, data and information furnished by BASF hereunder are provided gratis and BASF assumes no obligation or liability for the description, designs data and information given or results obtained, all such being given and accepted at your risk.

BASF Corporation, 1609 Biddle Avenue, Wyandotte, Michigan 48192 (800) 892-3111 x21, www.basf.com/elastollan

©BASF Corporation 2000

BASF

日本帝人化成聚碳酸酯樹脂 POLYCARBONATE RESIN "TEIJIN PANLITE"

規 格 型 號 特 性	比 重	透 光 率	彎 曲 強 度	衝 擊 強 度	熱 變 形 溫 度	吸 收 率		耐 火 等 級	
						g/cm ³	3mm 厚 度 %		kg/cm ²
高衝擊級	I.E-1250	高衝擊、射出級	1.18	半透明	21,500	85	134	0.5 ~ 0.9	HB
防火級	LN-1250 LN-2250	射出防火 V-0 具難型	1.23	80	22,300	80	136	0.5 ~ 0.7	V-0
	LN-1250G	射出防火 V-0 易難型	1.22	半透明	23,000	80	133	0.5 ~ 0.7	V-0
光高反射級	I.D-1000RM	全反射高衝擊透光性級	1.23	光線反射率 2mm 96 以上	25,000	80	134	0.4 ~ 0.6	
玻璃纖維強化級 PANLITE-G GLASS FIBRE REIN- FORCED GRADE	G-3110	射出玻璃纖維 10 %	1.27	半透明	36,000	9	146	0.3 ~ 0.5 0.4 ~ 0.5	V-2 V-0
	G-3115	射出玻璃纖維 15 %	1.30	半透明	45,000	12	147	0.3 ~ 0.4 0.4 ~ 0.5	V-2 V-0
	G-3120	射出玻璃纖維 20 %	1.34	半透明	55,000	14	148	0.1 ~ 0.3 0.4 ~ 0.6	V-2 V-1
	G-3130	射出玻璃纖維 30 %	1.43	半透明	74,000	16	149	0.02 ~ 0.2 0.3 ~ 0.5	V-2 V-1
易成型級 PANLITE-G MOLD RELEASE GRADE	G-3110R	射出、易成型含玻璃纖維 10 %	1.27	不透明	36,500	9	145	0.2 ~ 0.5 0.4 ~ 0.6	V-2 V-0
	G-3130R	射出、易成型含玻璃纖維 30 %	1.43	不透明	74,000	12	150	0.02 ~ 0.2 0.3 ~ 0.5	V-2 V-1
外觀良好級 PANLITE-G GOOD APPEARANCE G- GRADE	G-3110H	射出、低彎曲含玻璃纖維 10 %	1.27	半透明	34,500	5	140	0.3 ~ 0.5 0.4 ~ 0.6	V-2 V-0
	G-3115H	射出、低彎曲含玻璃纖維 15 %	1.30	半透明	40,000	6		0.2 ~ 0.4 0.4 ~ 0.6	V-2 V-0
	G-3120H	射出、低彎曲含玻璃纖維 20 %	1.34	半透明	47,000	6		0.2 ~ 0.4 0.4 ~ 0.5	V-2 V-0
	G-3124H	射出、低彎曲含玻璃纖維 24 %		半透明	52,000	7		0.1 ~ 0.3 0.4 ~ 0.5	V-2 V-0
	G-3130H	射出、低彎曲含玻璃纖維 30 %	1.43	半透明	65,000	9	140	0.1 ~ 0.3 0.3 ~ 0.5	V-2 V-1
低彎曲級 PANLITE-G LOW ANISOTROPIC G- GRADE	G-3110M	射出超低彎曲、外觀良好 含玻璃纖維 10 %	1.27	半透明	25,900	8	133	0.5 ~ 0.7	V-2 V-0
	G-3115M	射出超低彎曲、外觀良好含玻璃纖維 15 %	1.30	半透明	28,500	5	140	0.4 ~ 0.6	V-2
	G-3120M	射出超低彎曲、外觀良好含玻璃纖維 20 %	1.34	半透明	31,500	4	141	0.4 ~ 0.6	V-2
	G-3130M	射出超低彎曲、外觀良好 含玻璃纖維 30 %	1.43	半透明	40,000	2	135	0.3 ~ 0.5	V-2 V-1
玻璃纖維強化難燃級 FLAME RETARD GRADE	GN-3110	射出防火含玻璃纖維 10 %	1.26	半透明	35,000	7	146	0.3 ~ 0.5 0.4 ~ 0.5	V-0
	GN-3120	射出防火含玻璃纖維 20 %		半透明					V-0
	GN-3130	射出防火含玻璃纖維 30 %	1.44	半透明	75,000	12	145	0.02 ~ 0.2 0.3 ~ 0.5	V-0
FRICITION & ABRASION RESISTANT 耐磨、耐蝕級	GS-3130	射出、耐磨、耐蝕含玻璃纖維 30 %	1.51	半透明	77,000	14	150	0.02 ~ 0.2 0.3 ~ 0.5	V-1 V-0
	LS-1250	射出耐磨、耐蝕	1.23	半透明	21,500	12	136	0.5 ~ 0.7	V-2 V-0

◎ 以上表所列數值 僅供參考用

QMFZ2 Component - Plastics

Sunday, March 15, 1998

E50075

TEIJIN CHEMICALS LTD

HIBIYA DAIBIRU BLDG 2-2 UCHISAIWAI-CHO 1-CHOME CHIYODA-KU TOKYO 100-0011 JAPAN

Material Designation: **LN-1250G#(f1)***

Product Description: Polycarbonate (PC), designated "Panlife" furnished as pellets, powder.

Color	Min. Thick (mm)	Flame Class	HWI	HAI	RTIElec	RTIImp	RTI Str	IEC GWIT	IEC GWFI
ALL	1.0	V-0	1	2	125	105	115	-	-
	1.5	V-0	3	0	125	115	125	-	-
	3.0	V-0	3	0	125	115	125	-	-
	6.0	V-0	2	0	125	115	125	-	-

CTI: 3

HVTR: 3

D495: 6

IEC BP: -

Material designation may be suffixed with any one or two letters.

(f1) Suitable for outdoor use with respect to exposure to Ultraviolet Light, Water Exposure and Immersion in accordance with UL 746C.

* All colors except clear.

Report Date: 05/11/1989

Underwriters Laboratories Inc®

699748006

UL94 small-scale test data does not pertain to building materials, furnishings and related contents. UL 94 small-scale test data is intended solely for determining the flammability of plastic materials used in components and parts of end-product devices and appliances, where the acceptability of the combination is determined by ULL.

SPECIFICATION

1. Kind of Product : RFX50-SS32-113S

2. Character of conductor :

Item	Material	Unit	Detail of spec.
1. Conductor	Material	----	Silver-plated copper stranded conductor
	Construction	No/mm	7/0.08
	Cond. Dia.	mm	0.24
2. Insulation	Material	----	Teflon FEP
	Outer dia.	mm	0.68 + 0.04 - 0.02
	Color	----	Natural color
	Material	----	Silver-plated copper wire
3. Braiding Conductor	Construction	No/mm	16/4/0.05
	Outer dia.	mm	Approx. 0.88
	Shielding	%	Min. 90
	Material	----	Teflon FEP
4. Extruding	Outer dia.	mm	1.13 + 0.08 - 0.05
	Color	----	#16-BLACK or other color
5. Bending radius	Without load	mm	5xΦ Cable
	With load	mm	10xΦ Cable

SPECIFICATION

3.Character of electrical :

		Ω /Km	Max. 597
1.Inner Conductor resistance			
2.AC Dielectric strength			500V for 1minute
3.Impedance	----	Ω	50±2
4.Capacitance (Nom.)	at 1 KHz	pF/m	95
	at 1 GHz	dB/m	2.0
	at 2 GHz	dB/m	2.9
	at 3 GHz	dB/m	3.6
	at 4 GHz	dB/m	4.2
	at 5 GHz	dB/m	4.7
5. Attenuation(Nom.)	at 5 GHz	dB/m	4.7
	at 6 GHz	dB/m	5.2

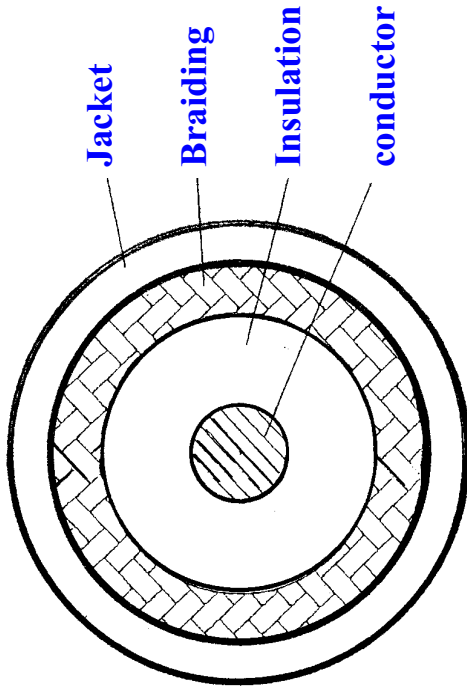

4.Packing : 250 mm Plastic reel (reel weight 0.5Kg)

5.Each length per reel : **1500 Meters** (Approx. Gross weight **5.1Kg**)

Customer Approval:

Approval: DonyLu C. C

Design : K.M.LU

93.8.5

SPECIFICATION FOR APPROVAL

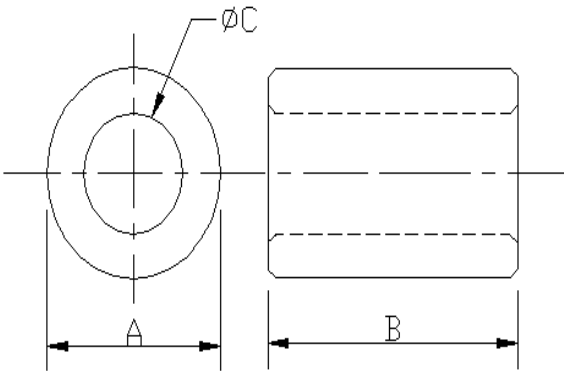
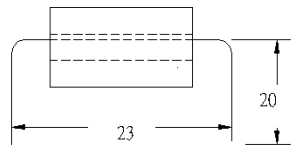
CUSTOMER:		CUST.P/N:	
ITEM:	K5B RH 4x10x2	K.C.P/N: PS0404IA	
<p>(1) SHAPE :</p> 	A	4.0±0.2 m/m	
	B	10.0±0.4 m/m	
	C	2.0±0.15 m/m	
	D	m/m	
	E	m/m	
	F	m/m	
	G	m/m	
<p>(2) ELECTRICAL REQUIREMENTS:</p> <p>$Z_1 = 37^{-0}$ OHM AT 25 MHz</p> <p>$Z_2 = 63^{-0}$ OHM AT 100 MHz</p>	<p>(3) TEST CONDITIONS:</p> <p>1 IMPEDANCE ANALYZER IHP4191A</p> <p>TEST FIXTURE: HP16092A</p> <p>2. WIRE: $\Phi 0.65$ T.C.W*63m/m/2Ts</p> <p>3. DRAWING:</p> 		
<p>(4) PACKING</p> <p><input checked="" type="checkbox"/> IN BULK <input type="checkbox"/> VACUUM <input type="checkbox"/> INSERTION</p> <p>2000 PCS/BAGS* 4 BAG/INNER BOX* 4 BOXES/CARTON = 32000 PCS</p> <p>PCS/PLATE* PLATES/CARTON= PCS</p> <p>PCS/TRAY* TRAYS/CARTON= PCS</p>	<p>(5) APPEARANCE</p> <p>(1) AREA OF BREAK : <2 m/m²</p> <p>(2) SUM OF BREAKING AREA : <3 m/m²</p> <p>(3) DEPTH OF BREAK : <1 m/m</p>		
<p>(6) REMARK:</p>	Approved by 黃國章		
	Checked by 吳明珠		
	Drawn by 吳明珠		
	DWG.NO.		

TEST DATA FOR PREPRODUCTION SAMPLES

CUSTOMER				CUST. P/N		
ITEM	<i>K5B RH 4x10x2</i>			K.C. P/N	<i>PS0404IA</i>	
TEMP.	24 °C	RH	69 %	DWG.NO.		
WIRE	0.65x63m/m T.C.W	WINDING	1/2 Ts	Q'TY		
Test Instruments						
Meas. Item.	Z (OHM)	Z (OHM)	A m/m	B m/m	C m/m	
Spec./ Yours.						
Spec./Suggest.	37⁻⁰	63⁻⁰	4.0±0.2	10.0±0.4	2.0±0.15	
Test Freq.	25 MHZ	100 MHZ				
1	51	85	4.08	10.06	2.04	
2	50	84	4.06	10.12	2.02	
3	50	84	4.04	10.10	2.00	
4	50	84	4.04	10.10	2.00	
5	51	85	4.04	10.06	2.00	
6						
7						
8						
9						
10						
\bar{X}	50	84	4.05	10.09	2.01	
R	1	1	0.04	0.06	0.04	
Your Sample.						
REMARK:				Approved by: 吴明珠		
				Checked by: 吴明珠		
				Drawn by: 吴明珠		

KING CORE ELECTRONICS INC.

K5B RH 4x10x2

