



Test Report

Product Name : Portable Navigation Device
Model No. : GPsmile 61, GPsmile 61XX
FCC ID. : RJINAV61XX

Applicant : Holux Technology, Inc.

Address : 1F, No.30, R&D Rd. II, Hsinchu City 300, Taiwan (R.O.C.)

Date of Receipt : 2008/03/28
Issued Date : 2008/05/08
Report No. : 084148R-RFUSP06V01
Version : V1.0

The test results relate only to the samples tested.

The test report shall not be reproduced except in full without the written approval of QuieTek Corporation.

TABLE OF CONTENTS

Description	Page
1. General Information.....	5
1.1. EUT Description	5
1.2. Operational Description	7
1.3. Test Mode	8
1.4. Tested System Details	9
1.5. Configuration of tested System.....	9
1.6. EUT Exercise Software.....	9
1.7. Test Facility.....	10
2. Conducted Emission	12
2.1. Test Equipment.....	12
2.2. Test Setup	12
2.3. Limits	13
2.4. Test Procedure	13
2.5. Test Specification.....	13
2.6. Test Result.....	14
2.7. Test Photo	18
3. Peak Power Output.....	19
3.1. Test Equipment.....	19
3.2. Test Setup	19
3.3. Test procedures	19
3.4. Limits.....	19
3.5. Test Specification.....	19
3.6. Test Result.....	20
4. Radiated Emission.....	23
4.1. Test Equipment.....	23
4.2. Test Setup	23
4.3. Limits.....	24
4.4. Test Procedure	24
4.5. Test Specification.....	24
4.6. Test Result.....	25
4.7. Test Photo	41
5. RF Conducted Emission	44
5.1. Test Equipment.....	44
5.2. Test Setup	44
5.3. Limits.....	45
5.4. Test Procedure	45
5.5. Test Specification.....	45
5.6. Test Result.....	46
6. Band Edge.....	48
6.1. Test Equipment.....	48
6.2. Test Setup	48
6.3. Limits.....	49
6.4. Test Procedure	49

6.5.	Test Specification.....	49
6.6.	Test Result.....	50
7.	Number of hopping frequency.....	58
7.1.	Test Equipment.....	58
7.2.	Test Setup	58
7.3.	Limits.....	59
7.4.	Test Procedures.....	59
7.5.	Test Specification.....	59
7.6.	Test Result.....	60
8.	Carrier Frequency Separation.....	64
8.1.	Test Equipment.....	64
8.2.	Test Setup	64
8.3.	Limits.....	64
8.4.	Test Procedures.....	64
8.5.	Test Specification.....	64
8.6.	Test Result.....	65
9.	Occupied Bandwidth	68
9.1.	Test Equipment.....	68
9.2.	Test Setup	68
9.3.	Limits.....	69
9.4.	Test Procedures.....	69
9.5.	Test Specification.....	69
9.6.	Test Result.....	70
10.	Dwell Time.....	76
10.1.	Test Equipment.....	76
10.2.	Test Setup	76
10.3.	Limits.....	77
10.4.	Test Procedures.....	77
10.5.	Test Specification.....	77
10.6.	Test Result.....	78
Attachement		82
<input type="checkbox"/>	EUT Photograph.....	82

1. General Information

1.1. EUT Description

Product Name	Portable Navigation Device
Trade Name	HOLUX
Model No.	GPSmile 61, GPSmile 61XX
Frequency Range	2402~2480MHz
Channel Number	79
Type of Modulation	GFSK
Channel Control	Auto
Antenna Type	Soldered on PCB
Antenna Gain	2dBi

Component	
Earphone Cable	Phone, GP-DEH-903600-31, Non-Shielded, 1.0m
Car Charger	SEMDITECH, IC-MUB-GPSH-G
Cradle	ARKON CM014-KST
Power Adapter	DVE, DSA-15P-05 US 050100 I/ P: 100-240V 50/60Hz O/P: 5V, 2A Cable Out: Non-Shielded, 1.8m

Working Frequency of Each Channel							
Channel	Frequency	Channel	Frequency	Channel	Frequency	Channel	Frequency
Channel 00	2402 MHz	Channel 20	2422 MHz	Channel 40	2442 MHz	Channel 60	2462 MHz
Channel 01	2403 MHz	Channel 21	2423 MHz	Channel 41	2443 MHz	Channel 61	2463 MHz
Channel 02	2404 MHz	Channel 22	2424 MHz	Channel 42	2444 MHz	Channel 62	2464 MHz
Channel 03	2405 MHz	Channel 23	2425 MHz	Channel 43	2445 MHz	Channel 63	2465 MHz
Channel 04	2406 MHz	Channel 24	2426 MHz	Channel 44	2446 MHz	Channel 64	2466 MHz
Channel 05	2407 MHz	Channel 25	2427 MHz	Channel 45	2447 MHz	Channel 65	2467 MHz
Channel 06	2408 MHz	Channel 26	2428 MHz	Channel 46	2448 MHz	Channel 66	2468 MHz
Channel 07	2409 MHz	Channel 27	2429 MHz	Channel 47	2449 MHz	Channel 67	2469 MHz
Channel 08	2410 MHz	Channel 28	2430 MHz	Channel 48	2450 MHz	Channel 68	2470 MHz
Channel 09	2411 MHz	Channel 29	2431 MHz	Channel 49	2451 MHz	Channel 69	2471 MHz
Channel 10	2412 MHz	Channel 30	2432 MHz	Channel 50	2452 MHz	Channel 70	2472 MHz
Channel 11	2413 MHz	Channel 31	2433 MHz	Channel 51	2453 MHz	Channel 71	2473 MHz
Channel 12	2414 MHz	Channel 32	2434 MHz	Channel 52	2454 MHz	Channel 72	2474 MHz
Channel 13	2415 MHz	Channel 33	2435 MHz	Channel 53	2455 MHz	Channel 73	2475 MHz
Channel 14	2416 MHz	Channel 34	2436 MHz	Channel 54	2456 MHz	Channel 74	2476 MHz
Channel 15	2417 MHz	Channel 35	2437 MHz	Channel 55	2457 MHz	Channel 75	2477 MHz
Channel 16	2418 MHz	Channel 36	2438 MHz	Channel 56	2458 MHz	Channel 76	2478 MHz
Channel 17	2419 MHz	Channel 37	2439 MHz	Channel 57	2459 MHz	Channel 77	2479 MHz
Channel 18	2420 MHz	Channel 38	2440 MHz	Channel 58	2460 MHz	Channel 78	2480 MHz
Channel 19	2421 MHz	Channel 39	2441 MHz	Channel 59	2461 MHz		

The system receivers have input bandwidths that match the hopping channel bandwidths of their corresponding transmitters and shift frequencies in synchronization with the transmitted signals. Frequency hopping spread spectrum systems are not required to employ all available hopping channels during each transmission. The transmitter is presented with a continuous data stream. In addition, a system employing short transmission bursts must comply with the definition of a frequency hopping system and must distribute its 79 channels and over the minimum number of hopping channels (75 channels).

The incorporation of intelligence within a frequency hopping spread spectrum system that permits the system to recognize other users within the spectrum band so that it individually and independently chooses and adapts its hop sets to avoid hopping on occupied channels is permitted. The coordination of frequency hopping systems in any other manner for the express purpose of avoiding the simultaneous occupancy of individual hopping frequencies by multiple transmitters is not permitted.

Note:

1. This device is a Portable Navigation Device included a 2.4GHz receiving function, and 2.4GHz transmitting function.
2. The variation of model number is for different strategy of marketing.
3. These tests were conducted on a sample of the equipment for the purpose of demonstrating compliance with Part 15 Subpart C Paragraph 15.247 for spread spectrum devices.
4. Regards to the frequency band operation; the lowest , middle and highest frequency of channel were selected to perform the test, and then shown on this report.
5. This device is a composite device in accordance with Part 15 regulations. The function receiving was measured and made a test report that the report number is 084148R-RFUSP01V02 under Declaration of Conformity.

1.3. Test Mode

QuieTek has verified the construction and function in typical operation. All the test modes were carried out with the EUT in transmitting operation, which was shown in this test report and defined as follows:

Pre-Test Mode	
EMI	Mode 1: Transmit (Adapter) Mode 2: Transmit (Car Charger)
Final Test Mode	
EMI	Mode 1: Transmit (Adapter) Mode 2: Transmit (Car Charger)

Emission	
Conducted Emission	Yes
Peak Power Output	Yes
Radiated Emission	Yes
Band Edge	Yes
Channel of Number	Yes
Channel Separation	Yes
Occupied Bandwidth	Yes
Dwell Time	Yes

1.4. Tested System Details

The types for all equipments, plus descriptions of all cables used in the tested system (including inserted cards) are:

Product	Manufacturer	Model No.	Serial No.	FCC ID	Power Cord
1 Earphone	Phone	GP-DEH-903600-31	N/A	DoC	--

1.5. Configuration of tested System

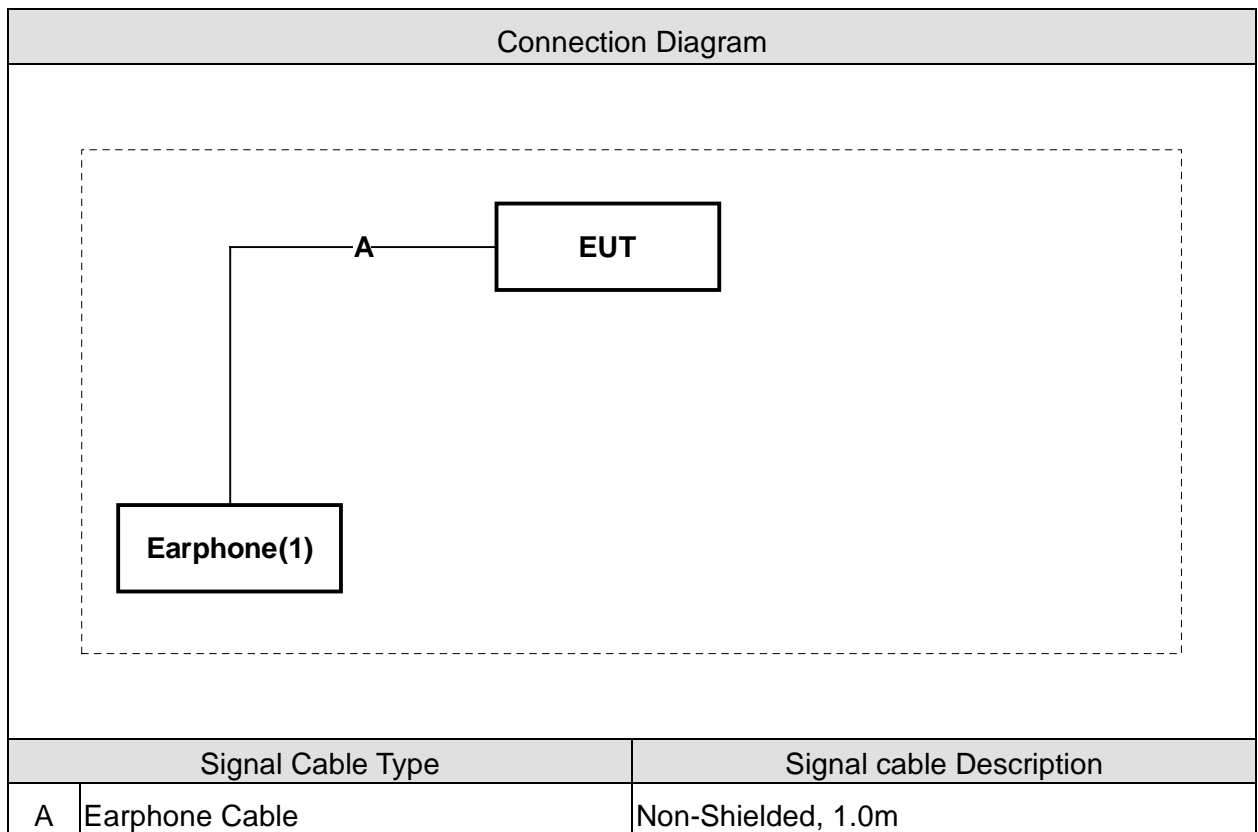

1.6. EUT Exercise Software

1	Setup the EUT and simulators as shown on 1.5.
2	Turn on the power of all equipment.
3	The EUT will play the function from Bluetooth program.
4	Verify the model operation.
5	Repeat the above procedure (3) to (4).

1.7. Test Facility

Ambient conditions in the laboratory:

Items	Test Item	Required (IEC 68-1)	Actual
Temperature (°C)	FCC PART 15 B 15.107 Conducted Emission	15 - 35	25
Humidity (%RH)		25 - 75	50
Barometric pressure (mbar)		860 - 1060	950-1000
Temperature (°C)	FCC PART 15 C 15.247 Peak Power Output (FHSS)	15 - 35	25
Humidity (%RH)		25 - 75	58
Barometric pressure (mbar)		860 - 1060	950-1000
Temperature (°C)	FCC PART 15 C 15.247 Radiated Emission (FHSS)	15 - 35	25
Humidity (%RH)		25 - 75	54
Barometric pressure (mbar)		860 - 1060	950-1000
Temperature (°C)	FCC PART 15 C 15.247 Band Edge (FHSS)	15 - 35	25
Humidity (%RH)		25 - 75	50
Barometric pressure (mbar)		860 - 1060	950-1000
Temperature (°C)	FCC PART 15 C 15.247 Channel Of Number (FHSS)	15 - 35	25
Humidity (%RH)		25 - 75	53
Barometric pressure (mbar)		860 - 1060	950-1000
Temperature (°C)	FCC PART 15 C 15.247 Channel Separation (FHSS)	15 - 35	25
Humidity (%RH)		25 - 75	54
Barometric pressure (mbar)		860 - 1060	950-1000
Temperature (°C)	FCC PART 15 C 15.247 Occupied Bandwidth (FHSS)	15 - 35	24
Humidity (%RH)		25 - 75	57
Barometric pressure (mbar)		860 - 1060	950-1000
Temperature (°C)	FCC PART 15 C 15.247 Dwell Time (FHSS)	15 - 35	25
Humidity (%RH)		25 - 75	58
Barometric pressure (mbar)		860 - 1060	950-1000

Site Description:

Accredited by NVLAP
NVLAP Lab Code: 200347-0
Effective through: September 30, 2008



March 23, 2008 Accreditation on DNV
Statement No. : 413-99-LAB11



March 27, 2008 Accreditation on TÜV Rheinland
Certificate No.: 10011438-2-2008



December 14, 2005 Accreditation on Nemko
Certificate No.: ELA 165

Accredited by TAF
Accreditation Number: 1313



Effective through: December 27, 2010
Site Name: Quietek Corporation



Site Address: No.75-1, Wang-Yeh Valley, Yung-Hsing,
Chiung-Lin, Hsin-Chu County,
Taiwan, R.O.C.
TEL : 886-3-5928858 / FAX : 886-3-5928859
E-Mail : service@quietek.com

2. Conducted Emission

2.1. Test Equipment

The following test equipment are used during the test:

Conducted Emission / SR2

Instrument	Manufacturer	Type No.	Serial No	Cal. Date
4-Wire ISN	R & S	ENY 41	837032/001	2008/04/15
Artificial Mains Network	R & S	ENV4200	848411/010	2008/03/13
Double 2-Wire ISN	R & S	ENY 22	835354/008	2008/04/15
LISN	R & S	ESH3-Z5	825562/002	2008/03/31
Pulse Limiter	R & S	ZSH3Z2	357.8810.54	2007/07/19
Test Receiver	R & S	ESCS 30	100122	2008/02/21

Note: All equipment upon which need to calibrated are with calibration period of 1 year.

2.2. Test Setup

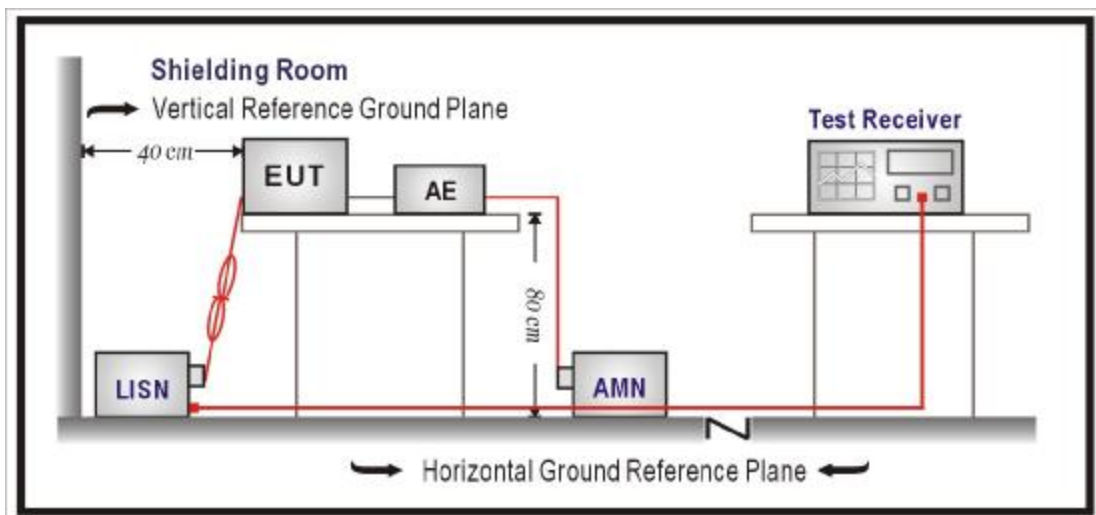

2.3. Limits

FCC Part 15 Subpart C Paragraph 15.207 Limits (dBuV)		
Frequency MHz	QP	AV
0.15 - 0.50	66-56	56-46
0.50-5.0	56	46
5.0 - 30	60	50

Remarks : In the above table, the tighter limit applies at the band edges.

2.4. Test Procedure

The EUT was setup and tested according to ANSI C63.4, 2003.

The EUT and simulators are connected to the main power through a line impedance stabilization network (L.I.S.N.). This provides a 50 ohm /50uH coupling impedance for the measuring equipment. The peripheral devices are also connected to the main power through a LISN that provides a 50ohm/50uH coupling impedance with 50ohm termination. (Please refers to the block diagram of the test setup and photographs.)

Both sides of A.C. line are checked for maximum conducted interference. In order to find the maximum emission, the relative positions of equipment and all of the interface cables must be changed according to ANSI C63.4: 2003 on conducted measurement.

Conducted emissions were investigated over the frequency range from 0.15MHz to 30MHz using a receiver bandwidth of 9kHz.

2.5. Test Specification

According to FCC Part 15 Subpart C Paragraph 15.207: 2006

2.6. Test Result

Site : ShieldingRoom 2	Time : 2008/04/23 - 10:08
Limit : CISPR_B_00M_QP	Margin : 0
EUT : Portable Navigation Device	Probe : QTK-LISN-SR2 - Line1
Power : AC 120V/60Hz	Note : Mode 1: Transmit (Adapter)

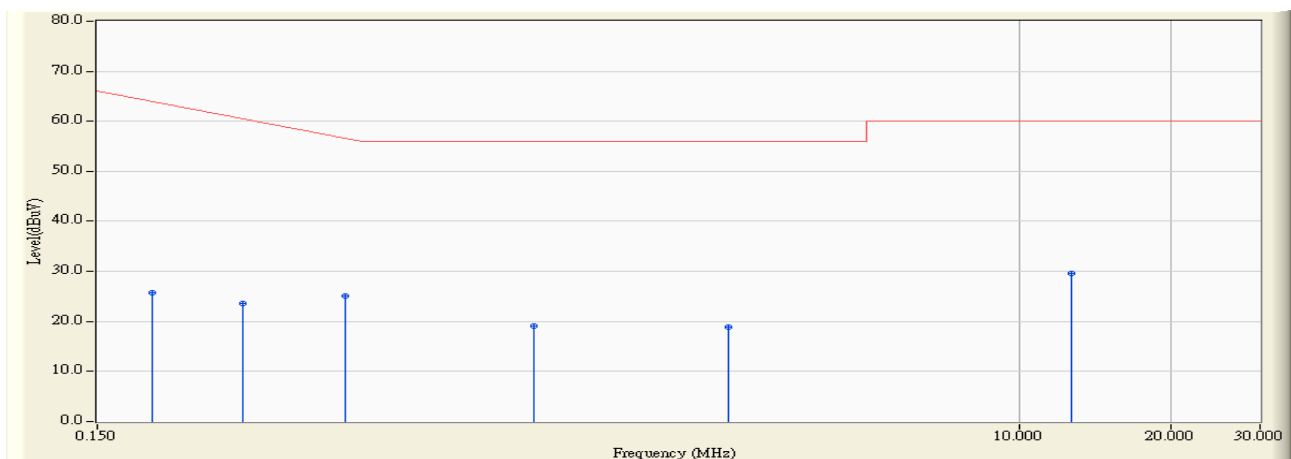

	Frequency (MHz)	Correct Factor (dB)	Reading Level (dBuV)	Measure Level (dBuV)	Margin (dB)	Limit (dBuV)	Detector Type
1	0.193	0.040	25.760	25.800	-38.971	64.771	QUASPEAK
2	0.291	0.044	23.510	23.554	-38.417	61.971	QUASPEAK
3	0.463	0.060	25.120	25.180	-31.877	57.057	QUASPEAK
4	1.095	0.080	18.960	19.040	-36.960	56.000	QUASPEAK
5	2.662	0.140	18.840	18.980	-37.020	56.000	QUASPEAK
6	* 12.673	0.780	28.880	29.660	-30.340	60.000	QUASPEAK

Note:

1. All Reading Levels are Quasi-Peak and average value.
2. " * ", means this data is the worst emission level.
3. Measurement Level = Reading Level + Correct Factor.

Engineer :	
Site : ShieldingrRoom 2	Time : 2008/04/23 - 10:08
Limit : CISPR_B_00M_AV	Margin : 0
EUT : Portable Navigation Device	Probe : QTK-LISN-SR2 - Line1
Power : AC 120V/60Hz	Note : Mode 1: Transmit (Adapter)

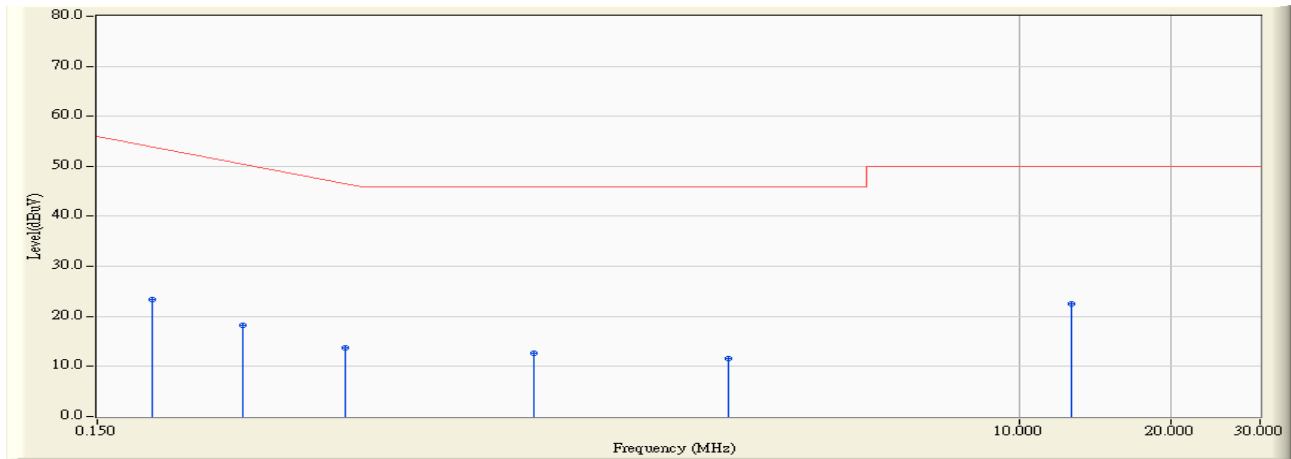

		Frequency (MHz)	Correct Factor (dB)	Reading Level (dBuV)	Measure Level (dBuV)	Margin (dB)	Limit (dBuV)	Detector Type
1		0.193	0.040	23.240	23.280	-31.491	54.771	AVERAGE
2		0.291	0.044	18.240	18.284	-33.687	51.971	AVERAGE
3		0.463	0.060	13.710	13.770	-33.287	47.057	AVERAGE
4		1.095	0.080	12.550	12.630	-33.370	46.000	AVERAGE
5		2.662	0.140	11.360	11.500	-34.500	46.000	AVERAGE
6	*	12.673	0.780	21.840	22.620	-27.380	50.000	AVERAGE

Note:

1. All Reading Levels are Quasi-Peak and average value.
2. " * ", means this data is the worst emission level.
3. Measurement Level = Reading Level + Correct Factor.

Engineer :	
Site : ShieldingRoom 2	Time : 2008/04/23 - 10:14
Limit : CISPR_B_00M_QP	Margin : 0
EUT : Portable Navigation Device	Probe : QTK-LISN-SR2 - Line2
Power : AC 120V/60Hz	Note : Mode 1: Transmit (Adapter)

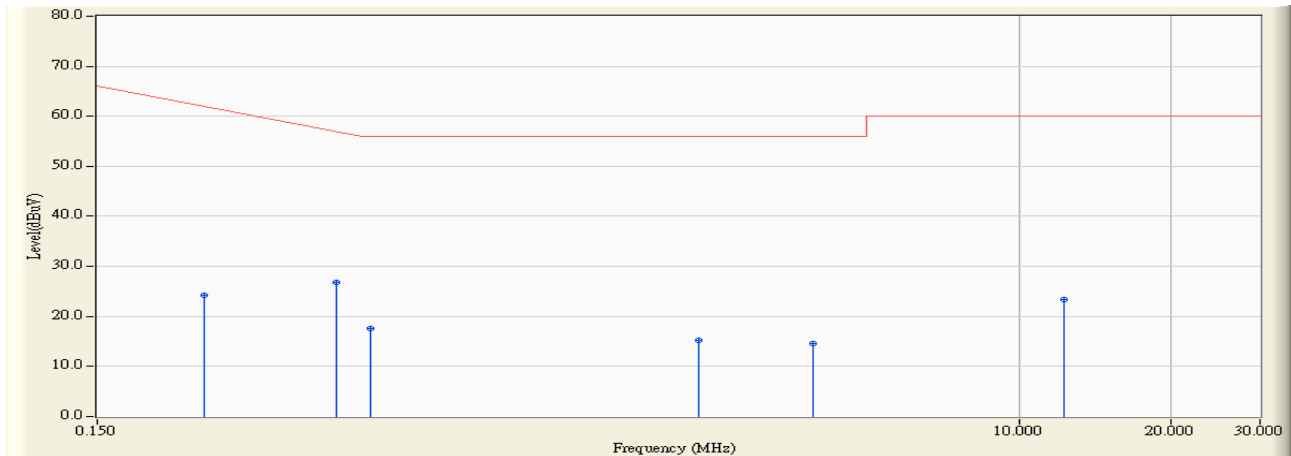

		Frequency (MHz)	Correct Factor (dB)	Reading Level (dBuV)	Measure Level (dBuV)	Margin (dB)	Limit (dBuV)	Detector Type
1		0.244	0.030	24.160	24.190	-39.124	63.314	QUASIPeAK
2	*	0.447	0.050	26.790	26.840	-30.674	57.514	QUASIPeAK
3		0.521	0.050	17.510	17.560	-38.440	56.000	QUASIPeAK
4		2.326	0.110	15.050	15.160	-40.840	56.000	QUASIPeAK
5		3.923	0.180	14.470	14.650	-41.350	56.000	QUASIPeAK
6		12.314	0.590	22.880	23.470	-36.530	60.000	QUASIPeAK

Note:

1. All Reading Levels are Quasi-Peak and average value.
2. " * ", means this data is the worst emission level.
3. Measurement Level = Reading Level + Correct Factor.

Engineer :	
Site : ShieldingRoom 2	Time : 2008/04/23 - 10:14
Limit : CISPR_B_00M_AV	Margin : 0
EUT : Portable Navigation Device	Probe : QTK-LISN-SR2 - Line2
Power : AC 120V/60Hz	Note : Mode 1: Transmit (Adapter)

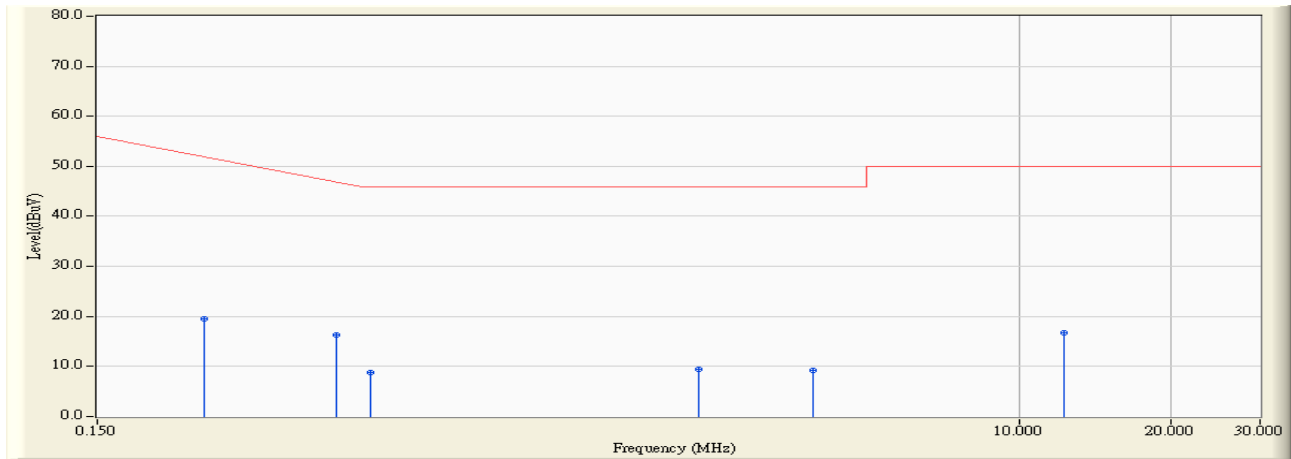

		Frequency (MHz)	Correct Factor (dB)	Reading Level (dBuV)	Measure Level (dBuV)	Margin (dB)	Limit (dBuV)	Detector Type
1		0.244	0.030	19.560	19.590	-33.724	53.314	AVERAGE
2	*	0.447	0.050	16.350	16.400	-31.114	47.514	AVERAGE
3		0.521	0.050	8.660	8.710	-37.290	46.000	AVERAGE
4		2.326	0.110	9.430	9.540	-36.460	46.000	AVERAGE
5		3.923	0.180	9.080	9.260	-36.740	46.000	AVERAGE
6		12.314	0.590	16.110	16.700	-33.300	50.000	AVERAGE

Note:

1. All Reading Levels are Quasi-Peak and average value.
2. " * ", means this data is the worst emission level.
3. Measurement Level = Reading Level + Correct Factor.

3. Peak Power Output

3.1. Test Equipment

The following test equipments are used during the test:

Item	Equipment	Manufacturer	Model No. / Serial No.	Last Cal.
1	Spectrum Analyzer	R&S	FSP/ 100005	Oct., 2007
2	No.1 OATS			Sep., 2007

Note: All equipment upon which need to calibrated are with calibration period of 1 year.

3.2. Test Setup

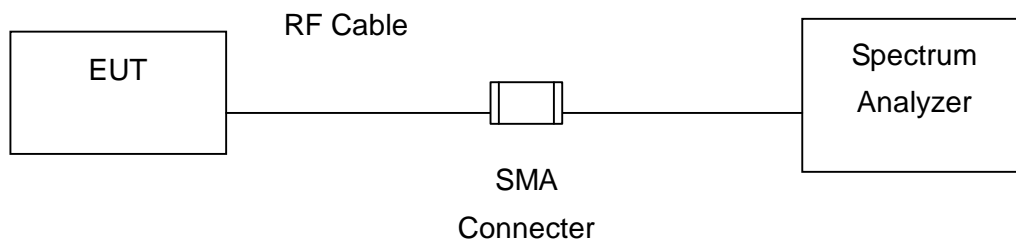

3.3. Test procedures

The EUT was setup according to ANSI C63.4, 2003 and tested according to FHSS test procedure of FCC Public Notice DA 00-705 for compliance to FCC 47CFR 15.247 requirements

3.4. Limits

For frequency hopping systems operating in the 902-928 MHz band: 1 Watt for systems employing at least 50 hopping channels; and, 0.25 Watts for systems employing less than 50 hopping channels.

For frequency hopping systems in the 2400-2483.5 MHz band employing at least 75 hopping channels, and all frequency hopping systems in the 5725-5850 MHz band: 1Watt. For all other frequency hopping systems in the 2400-2483.5 MHz band: 0.125 Watt.

3.5. Test Specification

According to FCC Part 15 Subpart C Paragraph 15.247: 2006

3.6. Test Result

Product	Portable Navigation Device		
Test Item	Peak Power Output		
Test Mode	Transmit		
Date of Test	2008/03/28	Test Site	No.1 OATS

Channel No.	Frequency (MHz)	Measure Level (dBm)	Limit (dBm)	Result
00	2402.00	-1.52	1Watt= 30 dBm	Pass

Channel 00

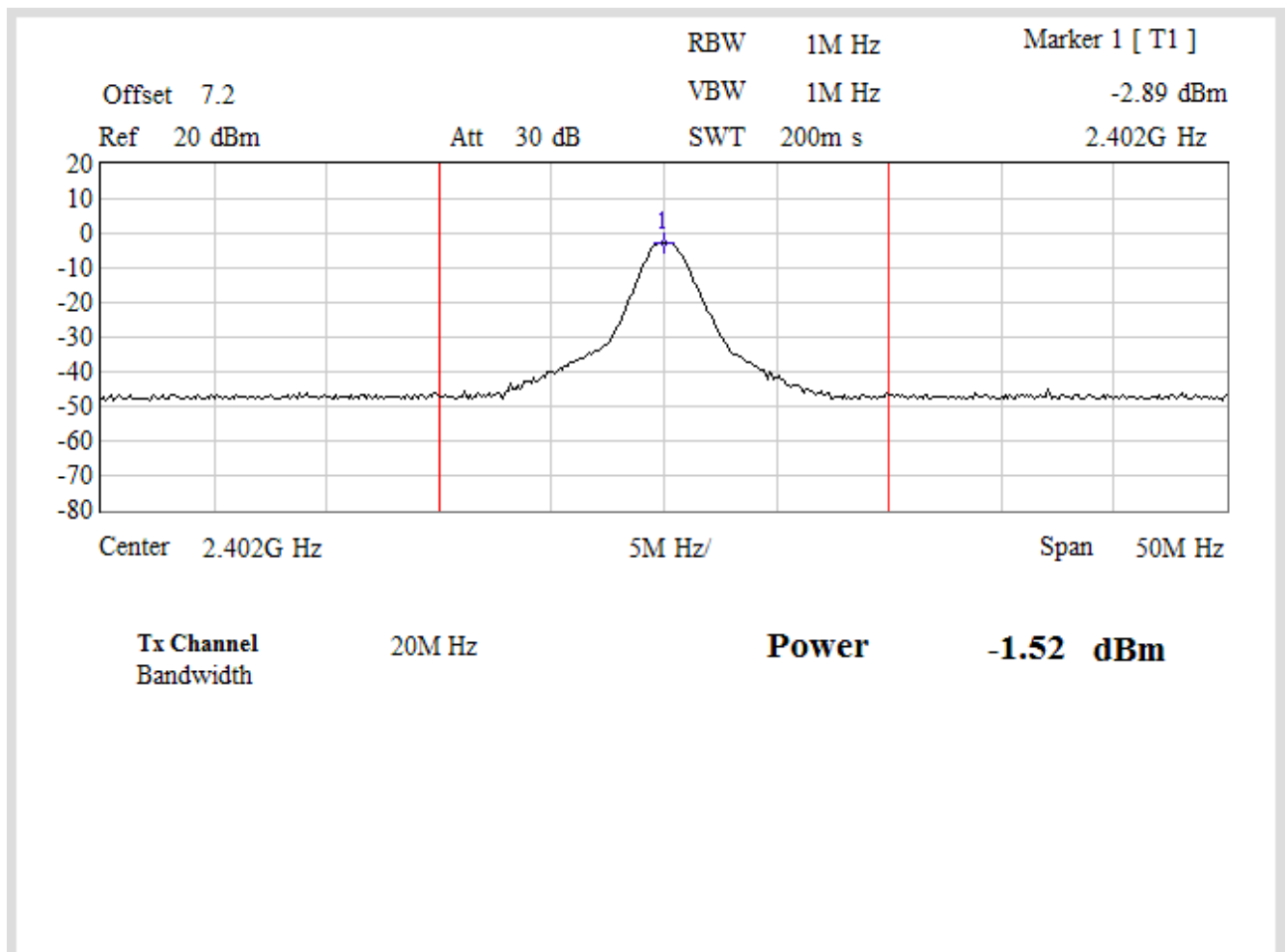

Product	Portable Navigation Device		
Test Item	Peak Power Output		
Test Mode	Transmit		
Date of Test	2008/03/28	Test Site	No.1 OATS

Channel No.	Frequency (MHz)	Measure Level (dBm)	Limit (dBm)	Result
39	2441.00	-2.02	1Watt= 30 dBm	Pass

Channel 39

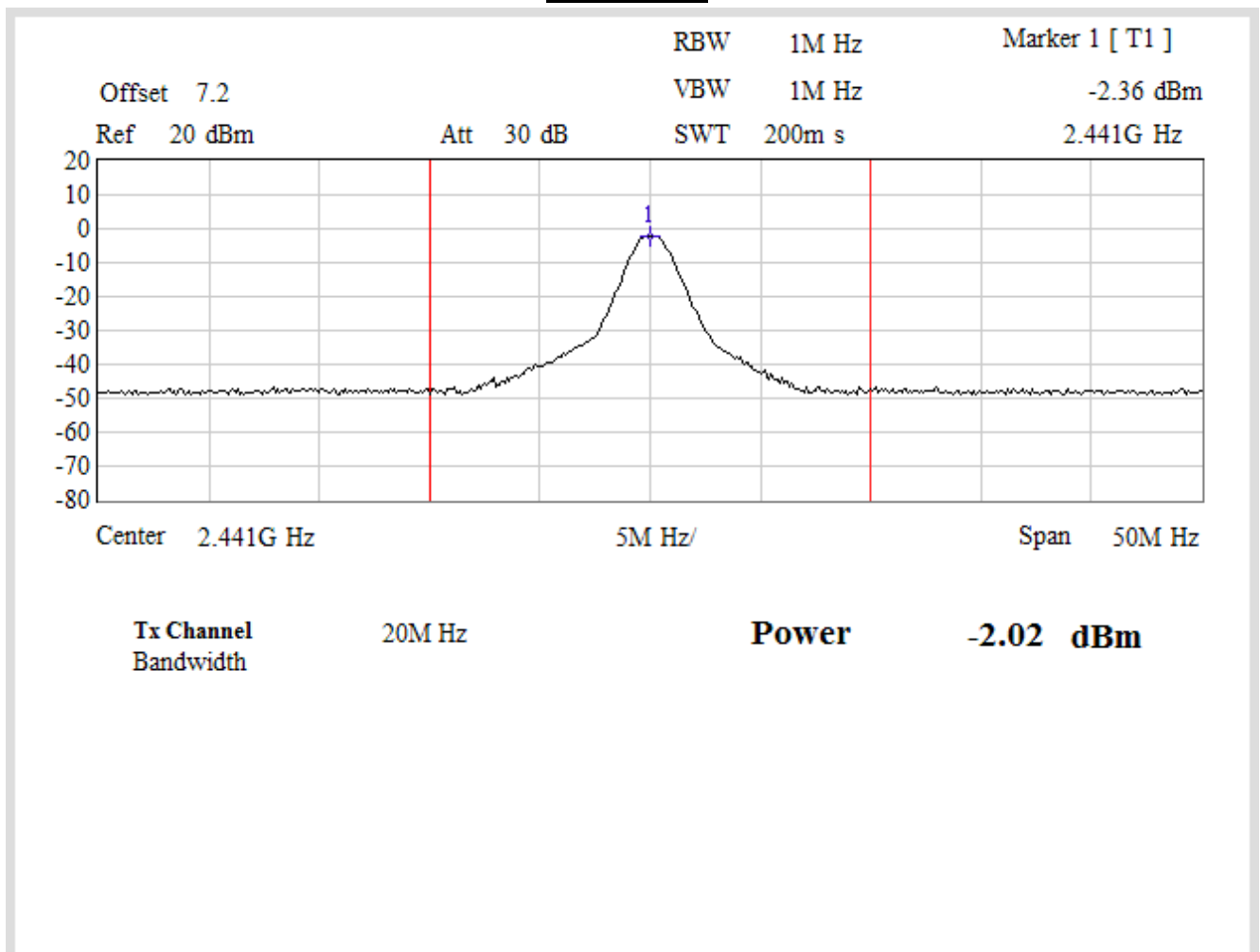

Product	Portable Navigation Device		
Test Item	Peak Power Output		
Test Mode	Transmit		
Date of Test	2008/03/28	Test Site	No.1 OATS

Channel No.	Frequency (MHz)	Measure Level (dBm)	Limit (dBm)	Result
78	2480.00	-3.2	1Watt= 30 dBm	Pass

Channel 78

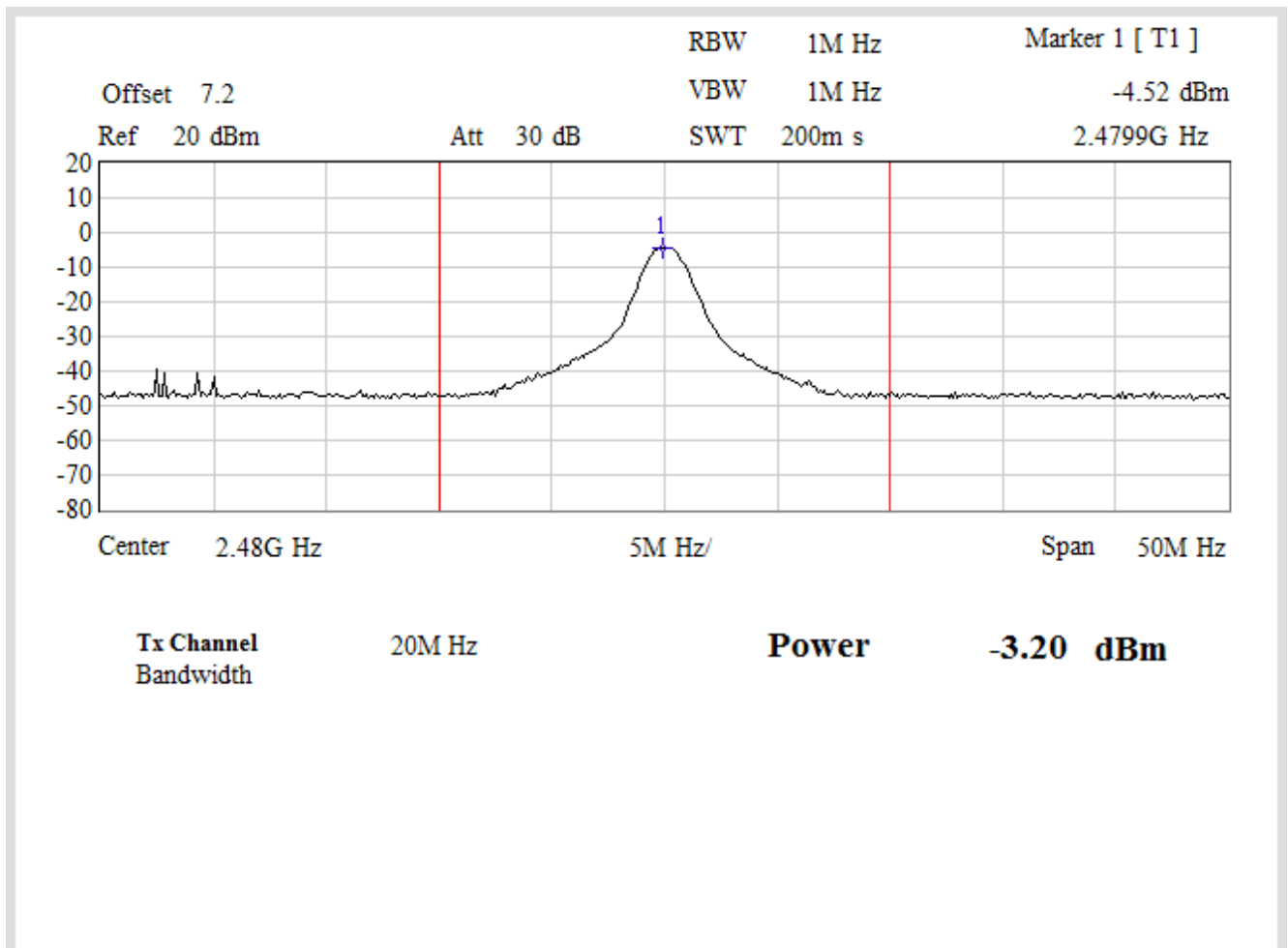

4. Radiated Emission

4.1. Test Equipment

The following test equipment are used during the test:

Radiated Emission / Site1

Instrument	Manufacturer	Type No.	Serial No	Cal. Date
Bilog Antenna	Schaffner Chase	CBL6112B	2895	2007/09/03
Horn Antenna	Electro Metrics	EM-6961	103325	2008/03/15
Pre-Amplifier	HP	8449B	3008A01123	2007/11/15
Pre-Amplifier	Quietek	AP-025C	N/A	N/A
Spectrum Analyzer	R & S	FSP40	100005	2007/08/25
Spectrum Analyzer	Advantest	R3162	120300649	2007/11/24
Test Receiver	R & S	ESCS 30	825442/017	2008/02/13

Note: 1. All equipments that need to calibrate are with calibration period of 1 year.
 2. "N/A" Ca1.Date is used to Pre-test, not final test.

4.2. Test Setup

Under 1GHz Test Setup:

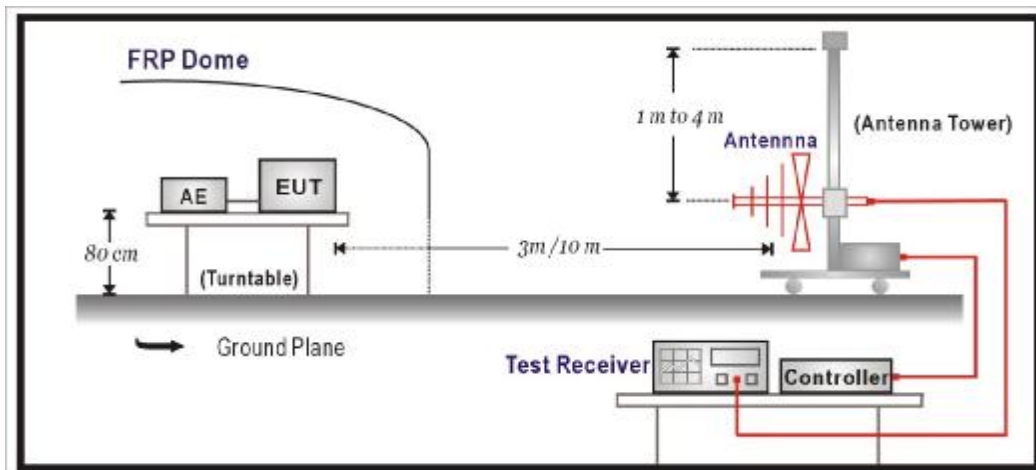

Above 1GHz Test Setup:

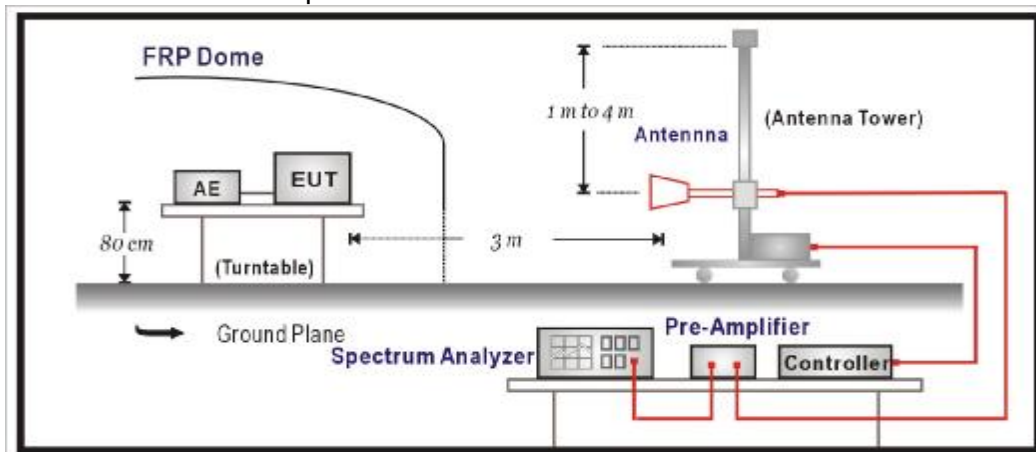

4.3. Limits

Emissions radiated outside of the specified frequency bands, except for harmonics, shall be attenuated by at least 20dB below the level of the fundamental or to the general radiated emission limits in paragraph 15.209, whichever is the lesser attenuation.

FCC Part 15 Subpart C Paragraph 15.209 Limits		
Frequency MHz	uV/m	dBuV/m
30-88	100	40
88-216	150	43.5
216-960	200	46
Above 960	500	54

- Remarks :
1. RF Voltage (dBuV) = 20 log RF Voltage (uV)
 2. In the Above Table, the tighter limit applies at the band edges.
 3. Distance refers to the distance in meters between the measuring instrument antenna and the closed point of any part of the device or system.

4.4. Test Procedure

The EUT and its simulators are placed on a turn table which is 0.8 meter above ground. The turn table can rotate 360 degrees to determine the position of the maximum emission level. The antenna can move up and down between 1 meter and 4 meters to find out the maximum emission level.

Both horizontal and vertical polarization of the antenna are set on measurement. In order to find the maximum emission, all of the interface cables must be manipulated according to ANSI C63.4:2003 on radiated measurement.

On any frequency or frequencies below or equal to 1000 MHz, the limits shown are based on measuring equipment employing a quasi-peak detector function and on any frequency or frequencies above 1000 MHz the radiated limits shown are based upon the use of measurement instrumentation employing an average detector function. When average radiated emission measurement are included emission measurement below 1000 MHz, there also is a limit on the radio frequency emissions, as measured using instrumentation with a peak detector function, corresponding to 20 dB above the maximum permitted average limit. The bandwidth below 1GHz setting on the field strength meter is 120 kHz and above 1GHz is 1MHz.

4.5. Test Specification

According to FCC Part 15 Subpart C Paragraph 15.247: 2006

4.6. Test Result

30MHz-1GHz Spurious:

Engineer :	Time : 2008/04/13 - 17:22
Site : Site 1	Margin : 6
Limit : FCC_CLASS_B_03M_QP	Probe : CB3_FCC_30-1G(2007) - HORIZONTAL
EUT : Portable Navigation Device	Power : AC 120V/60Hz
Note : Mode 1: Transmit (Adapter)	

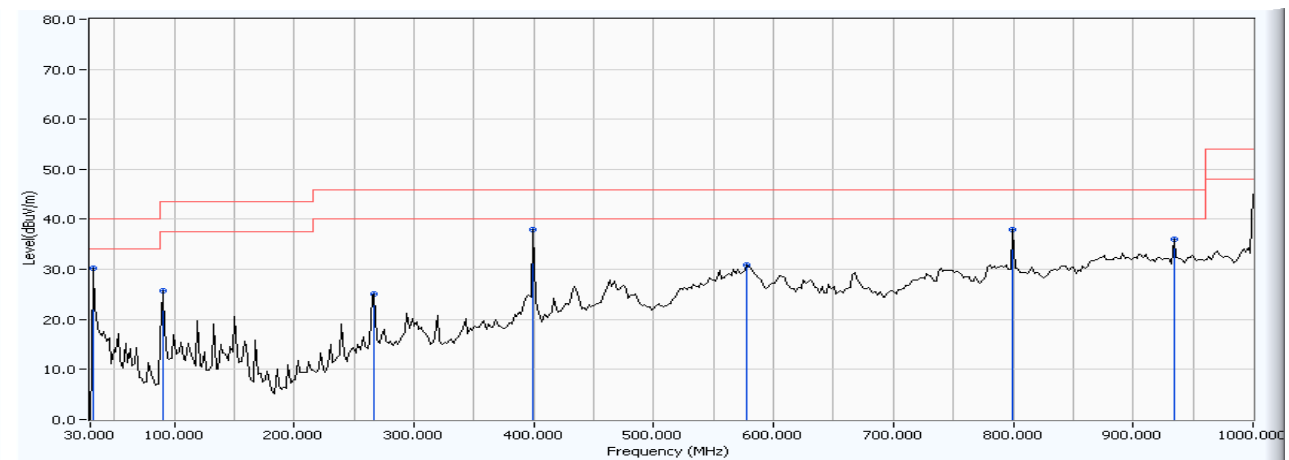

	Frequency (MHz)	Correct Factor (dB)	Reading Level (dBuV)	Measure Level (dBuV/m)	Margin (dB)	Limit (dBuV/m)	Detector Type
1	31.944	4.363	25.886	30.249	-9.751	40.000	Quasi_Peak
2	90.261	-8.388	34.230	25.842	-17.658	43.500	Quasi_Peak
3	267.154	-3.955	28.947	24.991	-21.009	46.000	Quasi_Peak
4	* 399.339	5.189	32.850	38.039	-7.961	46.000	Quasi_Peak
5	578.176	10.042	20.738	30.780	-15.220	46.000	Quasi_Peak
6	799.780	9.412	28.486	37.898	-8.102	46.000	Quasi_Peak
7	933.908	10.692	25.331	36.022	-9.978	46.000	Quasi_Peak

Note:

1. All Reading Levels are Quasi-Peak value.
2. “ * ”, means this data is the worst emission level.
3. Measurement Level = Reading Level + Correct Factor.

Engineer :	Time : 2008/04/13 - 17:26
Site : Site 1	Margin : 6
Limit : FCC_CLASS_B_03M_QP	Probe : CB3_FCC_30-1G(2007) - VERTICAL
EUT : Portable Navigation Device	Power : AC 120V/60Hz
Note : Mode 1: Transmit (Adapter)	

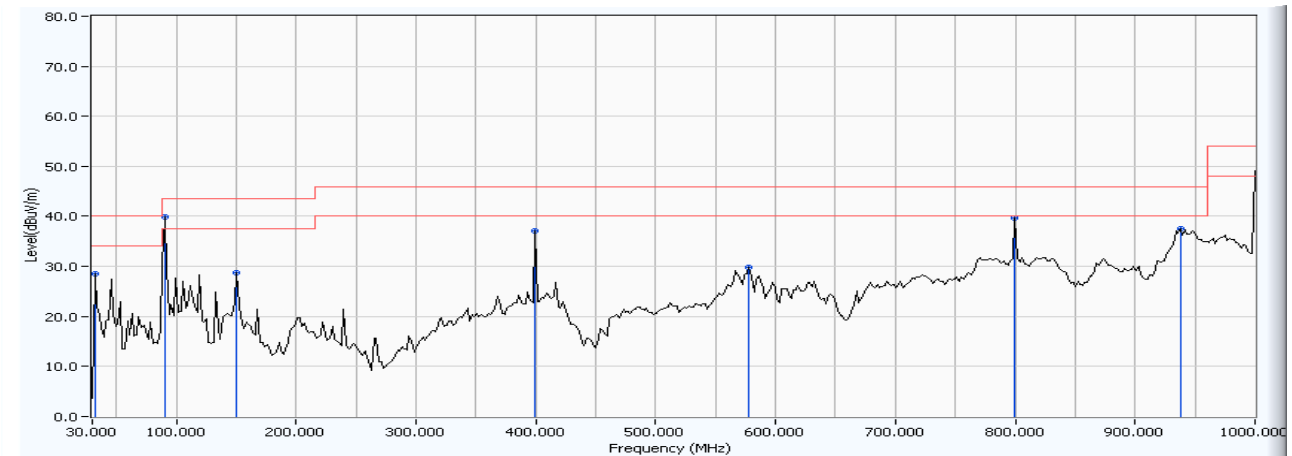

	Frequency (MHz)	Correct Factor (dB)	Reading Level (dBuV)	Measure Level (dBuV/m)	Margin (dB)	Limit (dBuV/m)	Detector Type
1	31.944	1.606	26.887	28.493	-11.507	40.000	Quasi_Peak
2	* 90.261	-1.148	41.009	39.861	-3.639	43.500	Quasi_Peak
3	150.521	-2.092	30.781	28.689	-14.811	43.500	Quasi_Peak
4	399.339	3.575	33.432	37.007	-8.993	46.000	Quasi_Peak
5	578.176	8.976	20.775	29.751	-16.249	46.000	Quasi_Peak
6	799.780	10.822	28.852	39.674	-6.326	46.000	Quasi_Peak
7	937.796	15.849	21.658	37.507	-8.493	46.000	Quasi_Peak

Note:

1. All Reading Levels are Quasi-Peak value.
2. “ * ”, means this data is the worst emission level.
3. Measurement Level = Reading Level + Correct Factor.

Engineer :	Time : 2008/04/21 - 10:41
Site : Site 1	Margin : 6
Limit : FCC_CLASS_B_03M_QP	Probe : CB3_FCC_30-1G(2007) - HORIZONTAL
EUT : Portable Navigation Device	Power : DC 12V
Note : Mode 2: Transmit (Car Charger)	

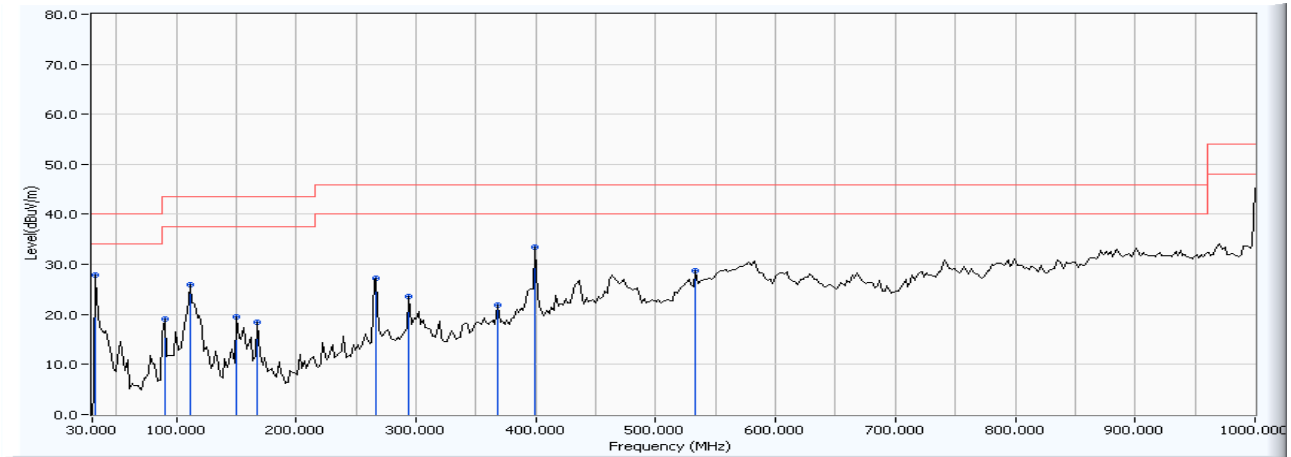

		Frequency (MHz)	Correct Factor (dB)	Reading Level (dBuV)	Measure Level (dBuV/m)	Margin (dB)	Limit (dBuV/m)	Detector Type
1	*	31.944	4.363	23.432	27.795	-12.205	40.000	Quasi_Peak
2		90.261	-8.388	27.576	19.188	-24.312	43.500	Quasi_Peak
3		111.643	-7.754	33.664	25.910	-17.590	43.500	Quasi_Peak
4		150.521	-11.610	31.127	19.517	-23.983	43.500	Quasi_Peak
5		168.016	-12.803	31.172	18.369	-25.131	43.500	Quasi_Peak
6		267.154	-3.955	31.258	27.302	-18.698	46.000	Quasi_Peak
7		294.369	-1.050	24.741	23.691	-22.309	46.000	Quasi_Peak
8		368.236	-0.983	22.959	21.976	-24.024	46.000	Quasi_Peak
9		399.339	5.189	28.182	33.371	-12.629	46.000	Quasi_Peak
10		533.467	5.528	23.145	28.673	-17.327	46.000	Quasi_Peak

Note:

1. All Reading Levels are Quasi-Peak value.
2. “ * ”, means this data is the worst emission level.
3. Measurement Level = Reading Level + Correct Factor.

Engineer :	Time : 2008/04/21 - 10:44
Site : Site 1	Margin : 6
Limit : FCC_CLASS_B_03M_QP	Probe : CB3_FCC_30-1G(2007) - VERTICAL
EUT : Portable Navigation Device	Power : DC 12V
Note : Mode 2: Transmit (Car Charger)	

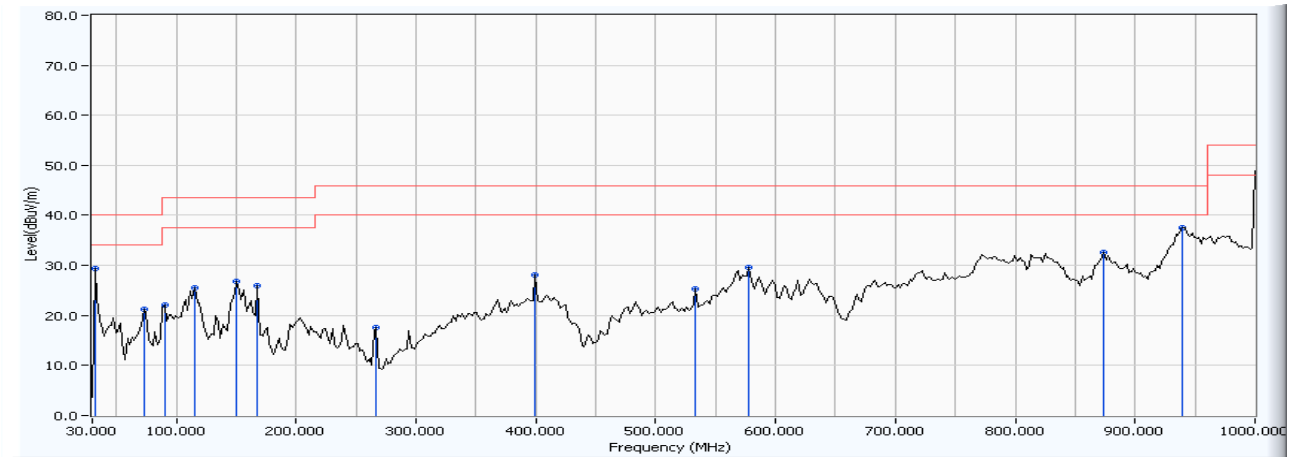

	Frequency (MHz)	Correct Factor (dB)	Reading Level (dBuV)	Measure Level (dBuV/m)	Margin (dB)	Limit (dBuV/m)	Detector Type
1	31.944	1.606	27.741	29.347	-10.653	40.000	Quasi_Peak
2	72.766	-6.486	27.703	21.217	-18.783	40.000	Quasi_Peak
3	90.261	-1.148	23.210	22.062	-21.438	43.500	Quasi_Peak
4	115.531	-0.397	25.986	25.589	-17.911	43.500	Quasi_Peak
5	150.521	-2.092	28.835	26.743	-16.757	43.500	Quasi_Peak
6	168.016	-3.652	29.594	25.941	-17.559	43.500	Quasi_Peak
7	267.154	-9.311	26.968	17.656	-28.344	46.000	Quasi_Peak
8	399.339	3.575	24.585	28.160	-17.840	46.000	Quasi_Peak
9	533.467	1.403	23.992	25.396	-20.604	46.000	Quasi_Peak
10	578.176	8.976	20.602	29.578	-16.422	46.000	Quasi_Peak
11	873.647	10.716	21.802	32.519	-13.481	46.000	Quasi_Peak
12	* 939.740	15.863	21.669	37.531	-8.469	46.000	Quasi_Peak

Note:

1. All Reading Levels are Quasi-Peak value.
2. " * ", means this data is the worst emission level.
3. Measurement Level = Reading Level + Correct Factor.

Harmonic & Spurious:

Engineer :	Time : 2008/04/13 - 11:56
Site : Site 1	Margin : 6
Limit : FCC_SpartC_15.247_H_03M_PK	Probe : CB4_FCC_1-18G(2007) - HORIZONTAL
EUT : Potable Navigation Device	Power : AC 120V/60Hz
Note : TX-2402MHz	

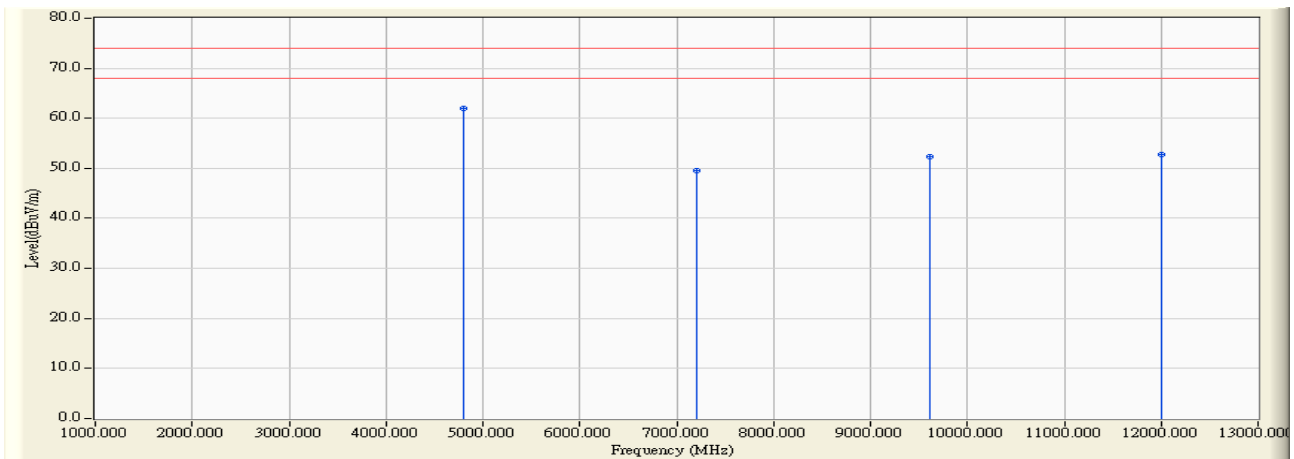

		Frequency (MHz)	Correct Factor (dB)	Reading Level (dBuV)	Measure Level (dBuV/m)	Margin (dB)	Peak Limit (dBuV/m)	Average Limit (dBuV/m)	Detector Type
1	*	4804.180	6.019	56.010	62.029	-11.971	74.000	54.000	PEAK
2		7206.020	12.604	36.990	49.594	-24.406	74.000	54.000	PEAK
3		9608.010	18.523	33.790	52.312	-21.688	74.000	54.000	PEAK
4		12010.020	20.169	32.630	52.799	-21.201	74.000	54.000	PEAK

Note:

1. All Readings below 1GHz are Peak, above are performed with peak and/or average measurements as necessary.
2. “ * ”, means this data is the worst emission level.
3. Measurement Level = Reading Level + Correct Factor.
4. The average measurement was not performed when the peak measured data under the limit of average detection. If the readings given are average, peak measurement should also be supplied.

Engineer :	Time : 2008/04/13 - 11:57
Site : Site 1	Margin : 6
Limit : FCC_SpartC_15.247_H_03M_AV	Probe : CB4_FCC_1-18G(2007) - HORIZONTAL
EUT : Potable Navigation Device	Power : AC 120V/60Hz
Note : TX-2402MHz	

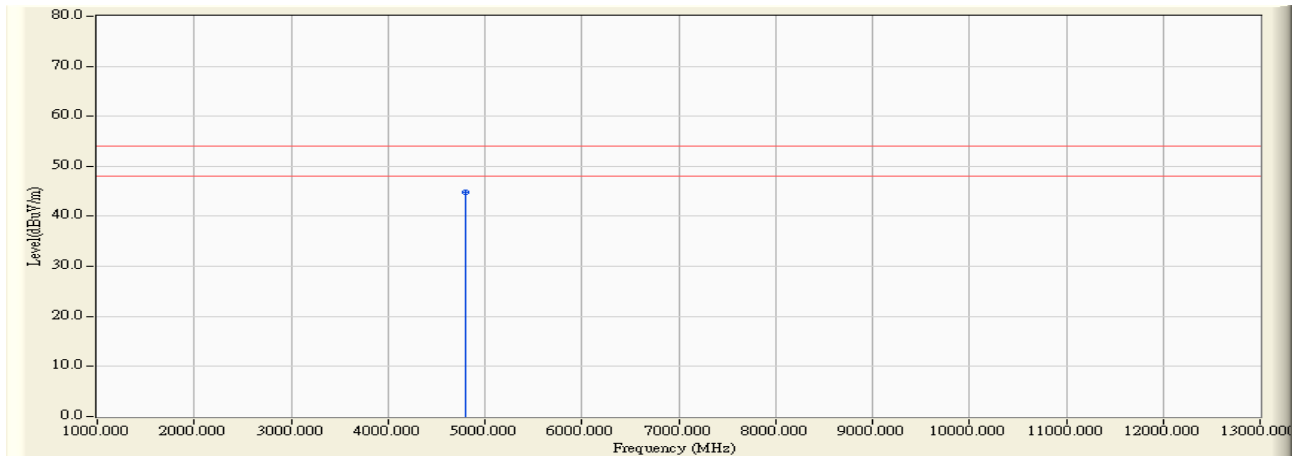

		Frequency (MHz)	Correct Factor (dB)	Reading Level (dBuV)	Measure Level (dBuV/m)	Margin (dB)	Peak Limit (dBuV/m)	Average Limit (dBuV/m)	Detector Type
1	*	4804.040	6.019	38.890	44.908	-9.092	74.000	54.000	AVERAGE

Note:

1. All Readings below 1GHz are average, above are performed with peak and/or average measurements as necessary.
2. “ * ”, means this data is the worst emission level.
3. Measurement Level = Reading Level + Correct Factor.
4. The average measurement was not performed when the peak measured data under the limit of average detection. If the readings given are average, peak measurement should also be supplied.

Engineer :	Time : 2008/04/13 - 12:05
Site : Site 1	Margin : 6
Limit : FCC_SpartC_15.247_H_03M_PK	Probe : CB4_FCC_1-18G(2007) - VERTICAL
EUT : Potable Navigation Device	Power : AC 120V/60Hz
Note : TX-2402MHz	

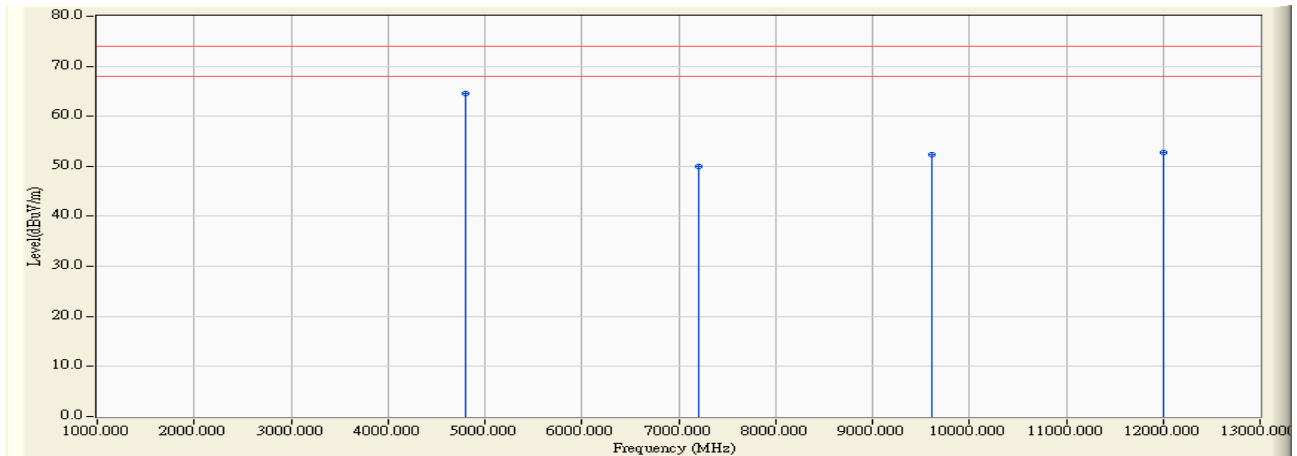

		Frequency (MHz)	Correct Factor (dB)	Reading Level (dBuV)	Measure Level (dBuV/m)	Margin (dB)	Peak Limit (dBuV/m)	Average Limit (dBuV/m)	Detector Type
1	*	4804.380	6.019	58.470	64.489	-9.511	74.000	54.000	PEAK
2		7206.040	13.016	36.860	49.876	-24.124	74.000	54.000	PEAK
3		9608.020	17.309	35.030	52.338	-21.662	74.000	54.000	PEAK
4		12009.980	20.150	32.670	52.820	-21.180	74.000	54.000	PEAK

Note:

1. All Readings below 1GHz are Peak, above are performed with peak and/or average measurements as necessary.
2. “ * ”, means this data is the worst emission level.
3. Measurement Level = Reading Level + Correct Factor.
4. The average measurement was not performed when the peak measured data under the limit of average detection. If the readings given are average, peak measurement should also be supplied.

Engineer :	Time : 2008/04/13 - 12:07
Site : Site 1	Margin : 6
Limit : FCC_SpartC_15.247_H_03M_AV	Probe : CB4_FCC_1-18G(2007) - VERTICAL
EUT : Potable Navigation Device	Power : AC 120V/60Hz
Note : TX-2402MHz	

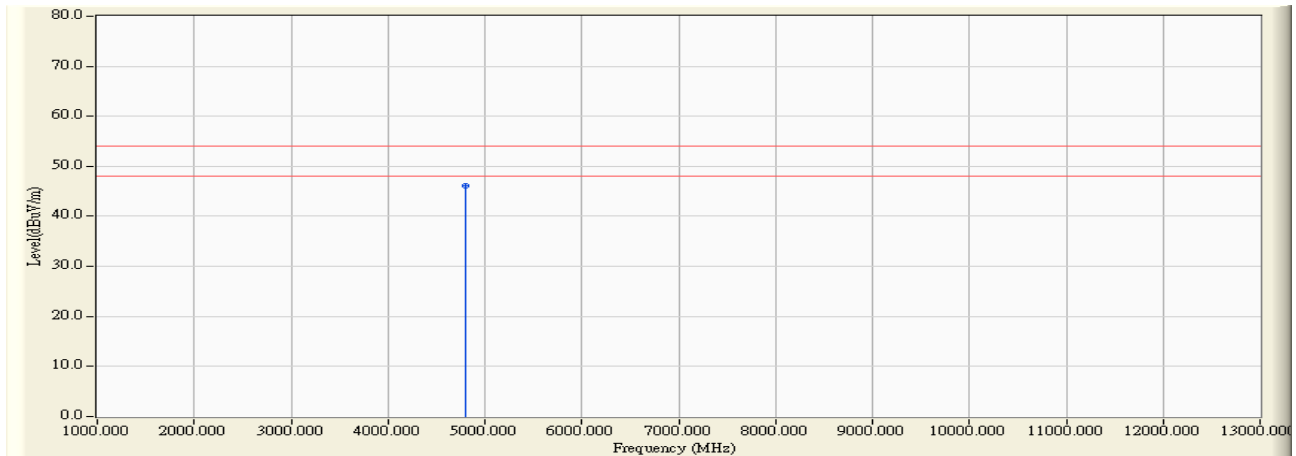

		Frequency (MHz)	Correct Factor (dB)	Reading Level (dBuV)	Measure Level (dBuV/m)	Margin (dB)	Peak Limit (dBuV/m)	Average Limit (dBuV/m)	Detector Type
1	*	4804.040	6.019	39.990	46.008	-7.992	74.000	54.000	AVERAGE

Note:

1. All Readings below 1GHz are average, above are performed with peak and/or average measurements as necessary.
2. “ * ”, means this data is the worst emission level.
3. Measurement Level = Reading Level + Correct Factor.
4. The average measurement was not performed when the peak measured data under the limit of average detection. If the readings given are average, peak measurement should also be supplied.

Engineer :	Time : 2008/04/13 - 12:16
Site : Site 1	Margin : 6
Limit : FCC_SpartC_15.247_H_03M_PK	Probe : CB4_FCC_1-18G(2007) - HORIZONTAL
EUT : Potable Navigation Device	Power : AC 120V/60Hz
Note : TX-2441MHz	

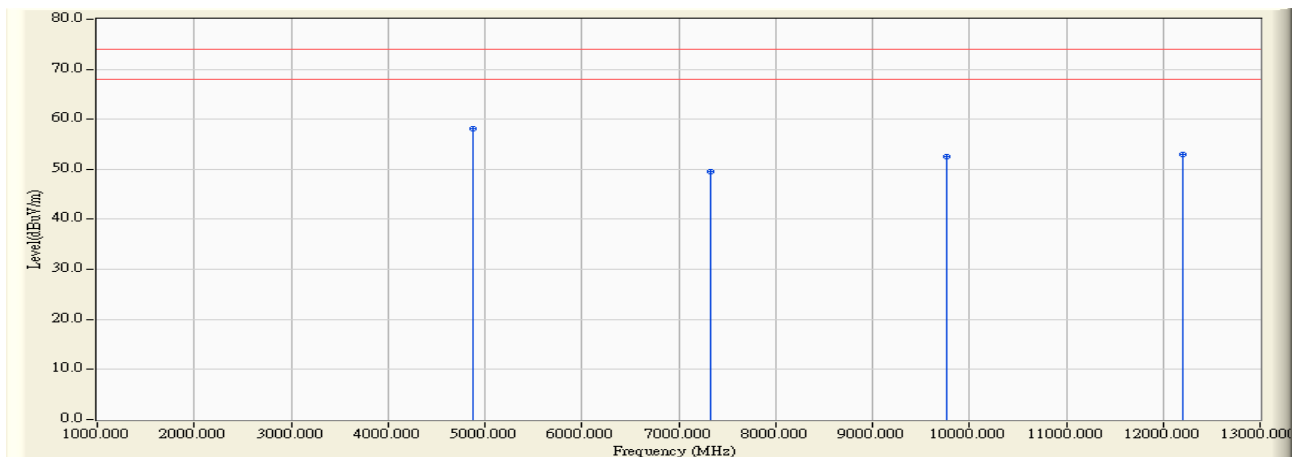

		Frequency (MHz)	Correct Factor (dB)	Reading Level (dBuV)	Measure Level (dBuV/m)	Margin (dB)	Peak Limit (dBuV/m)	Average Limit (dBuV/m)	Detector Type
1	*	4882.120	6.234	51.890	58.124	-15.876	74.000	54.000	PEAK
2		7323.010	13.056	36.430	49.487	-24.513	74.000	54.000	PEAK
3		9764.010	19.287	33.240	52.527	-21.473	74.000	54.000	PEAK
4		12205.020	20.543	32.450	52.994	-21.006	74.000	54.000	PEAK

Note:

1. All Readings below 1GHz are Peak, above are performed with peak and/or average measurements as necessary.
2. “ * ”, means this data is the worst emission level.
3. Measurement Level = Reading Level + Correct Factor.
4. The average measurement was not performed when the peak measured data under the limit of average detection. If the readings given are average, peak measurement should also be supplied.

Engineer :	Time : 2008/04/13 - 12:16
Site : Site 1	Margin : 6
Limit : FCC_SpartC_15.247_H_03M_AV	Probe : CB4_FCC_1-18G(2007) - HORIZONTAL
EUT : Potable Navigation Device	Power : AC 120V/60Hz
Note : TX-2441MHz	

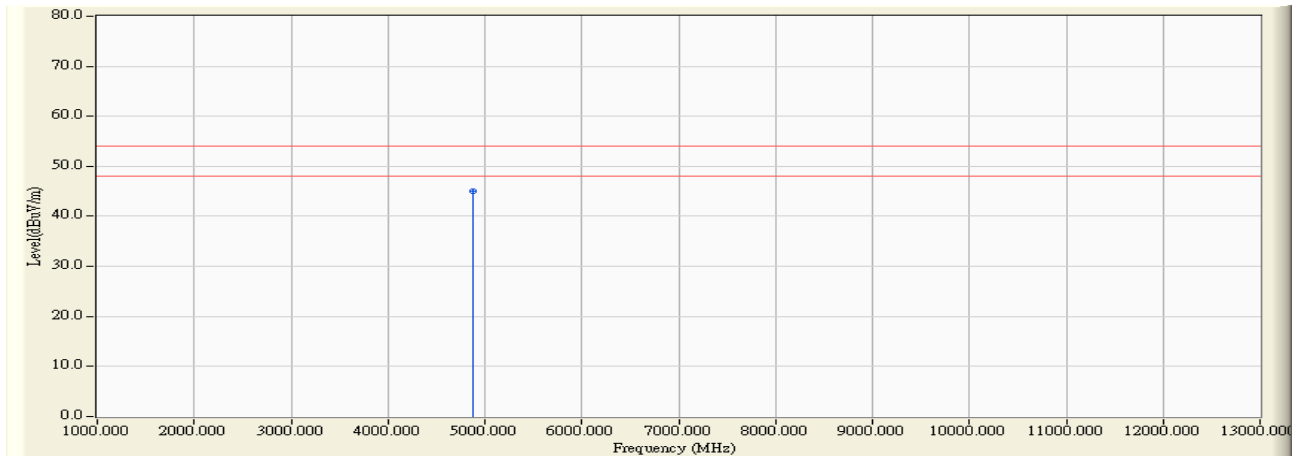

		Frequency (MHz)	Correct Factor (dB)	Reading Level (dBuV)	Measure Level (dBuV/m)	Margin (dB)	Peak Limit (dBuV/m)	Average Limit (dBuV/m)	Detector Type
1	*	4882.010	6.234	38.850	45.084	-8.916	74.000	54.000	AVERAGE

Note:

1. All Readings below 1GHz are average, above are performed with peak and/or average measurements as necessary.
2. “ * ”, means this data is the worst emission level.
3. Measurement Level = Reading Level + Correct Factor.
4. The average measurement was not performed when the peak measured data under the limit of average detection. If the readings given are average, peak measurement should also be supplied.

Engineer :	Time : 2008/04/13 - 12:25
Site : Site 1	Margin : 6
Limit : FCC_SpartC_15.247_H_03M_PK	Probe : CB4_FCC_1-18G(2007) - VERTICAL
EUT : Potable Navigation Device	Power : AC 120V/60Hz
Note : TX-2441MHz	

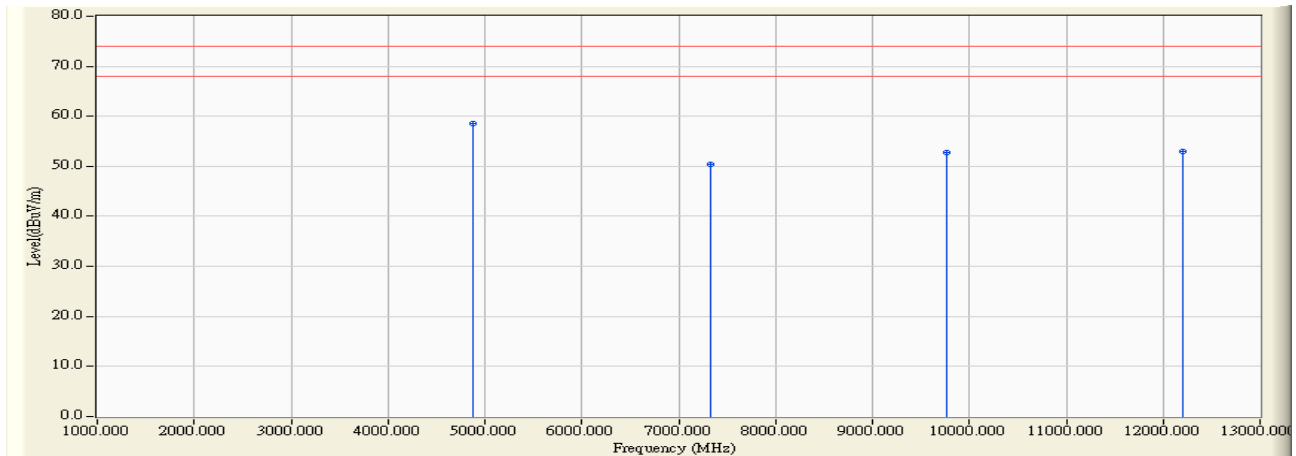

		Frequency (MHz)	Correct Factor (dB)	Reading Level (dBuV)	Measure Level (dBuV/m)	Margin (dB)	Peak Limit (dBuV/m)	Average Limit (dBuV/m)	Detector Type
1	*	4882.180	6.235	52.230	58.465	-15.535	74.000	54.000	PEAK
2		7323.000	13.703	36.780	50.484	-23.516	74.000	54.000	PEAK
3		9764.040	17.761	34.990	52.751	-21.249	74.000	54.000	PEAK
4		12205.010	20.130	32.740	52.870	-21.130	74.000	54.000	PEAK

Note:

1. All Readings below 1GHz are Peak, above are performed with peak and/or average measurements as necessary.
2. “ * ”, means this data is the worst emission level.
3. Measurement Level = Reading Level + Correct Factor.
4. The average measurement was not performed when the peak measured data under the limit of average detection. If the readings given are average, peak measurement should also be supplied.

Engineer :	Time : 2008/04/13 - 12:26
Site : Site 1	Margin : 6
Limit : FCC_SpartC_15.247_H_03M_AV	Probe : CB4_FCC_1-18G(2007) - VERTICAL
EUT : Potable Navigation Device	Power : AC 120V/60Hz
Note : TX-2441MHz	

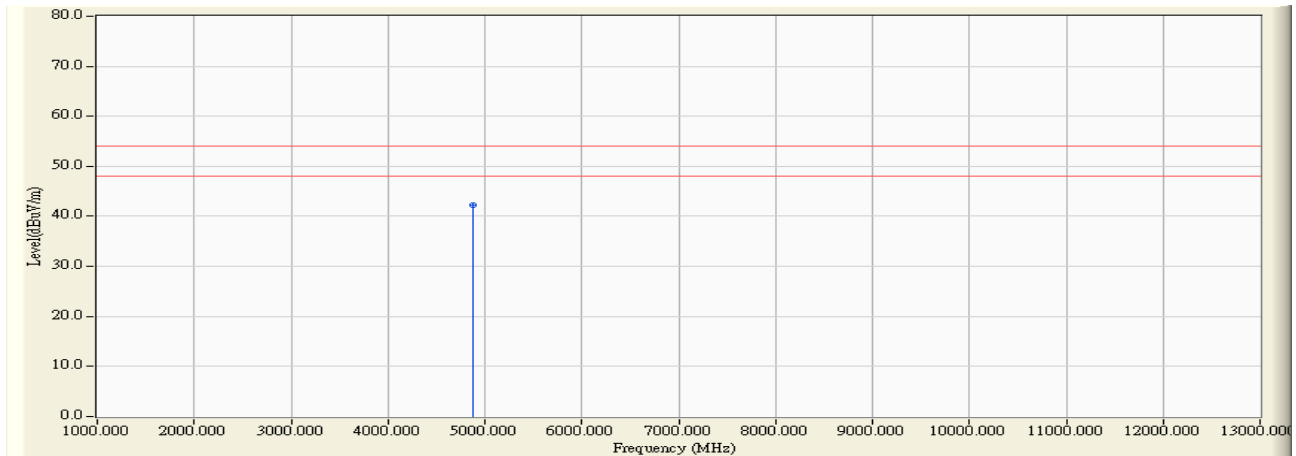

		Frequency (MHz)	Correct Factor (dB)	Reading Level (dBuV)	Measure Level (dBuV/m)	Margin (dB)	Peak Limit (dBuV/m)	Average Limit (dBuV/m)	Detector Type
1	*	4882.000	6.234	36.090	42.324	-11.676	74.000	54.000	AVERAGE

Note:

1. All Readings below 1GHz are average, above are performed with peak and/or average measurements as necessary.
2. “ * ”, means this data is the worst emission level.
3. Measurement Level = Reading Level + Correct Factor.
4. The average measurement was not performed when the peak measured data under the limit of average detection. If the readings given are average, peak measurement should also be supplied.

Engineer :	Time : 2008/04/13 - 12:32
Site : Site 1	Margin : 6
Limit : FCC_SpartC_15.247_H_03M_PK	Probe : CB4_FCC_1-18G(2007) - HORIZONTAL
EUT : Potable Navigation Device	Power : AC 120V/60Hz
Note : TX-2480MHz	

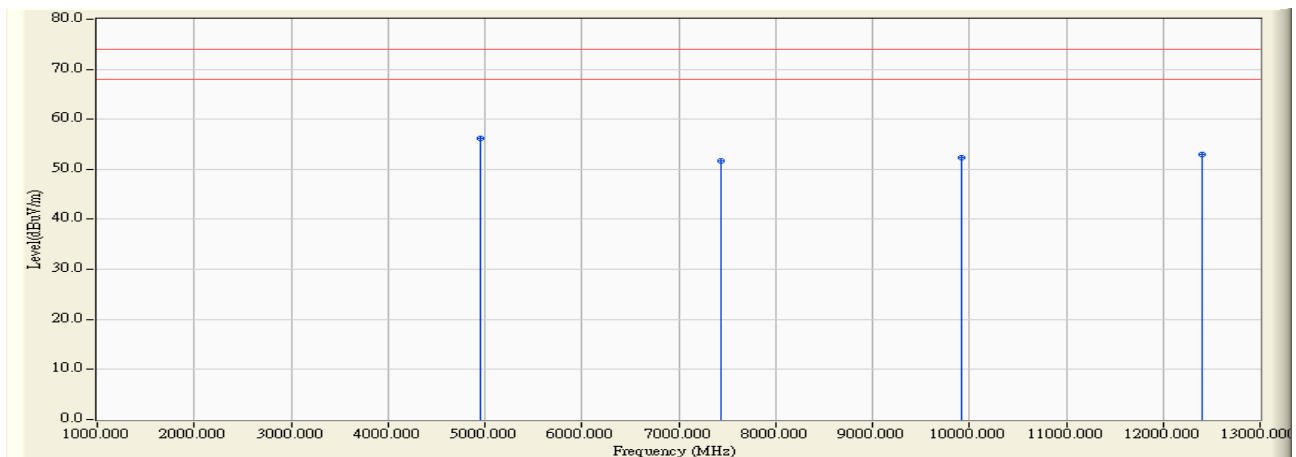

		Frequency (MHz)	Correct Factor (dB)	Reading Level (dBuV)	Measure Level (dBuV/m)	Margin (dB)	Peak Limit (dBuV/m)	Average Limit (dBuV/m)	Detector Type
1	*	4960.080	6.457	49.820	56.277	-17.723	74.000	54.000	PEAK
2		7439.980	13.527	38.060	51.588	-22.412	74.000	54.000	PEAK
3		9920.020	20.046	32.360	52.407	-21.593	74.000	54.000	PEAK
4		12400.000	20.918	31.970	52.888	-21.112	74.000	54.000	PEAK

Note:

1. All Readings below 1GHz are Peak, above are performed with peak and/or average measurements as necessary.
2. “ * ”, means this data is the worst emission level.
3. Measurement Level = Reading Level + Correct Factor.
4. The average measurement was not performed when the peak measured data under the limit of average detection. If the readings given are average, peak measurement should also be supplied.

Engineer :	Time : 2008/04/13 - 12:33
Site : Site 1	Margin : 6
Limit : FCC_SpartC_15.247_H_03M_AV	Probe : CB4_FCC_1-18G(2007) - HORIZONTAL
EUT : Potable Navigation Device	Power : AC 120V/60Hz
Note : TX-2480MHz	

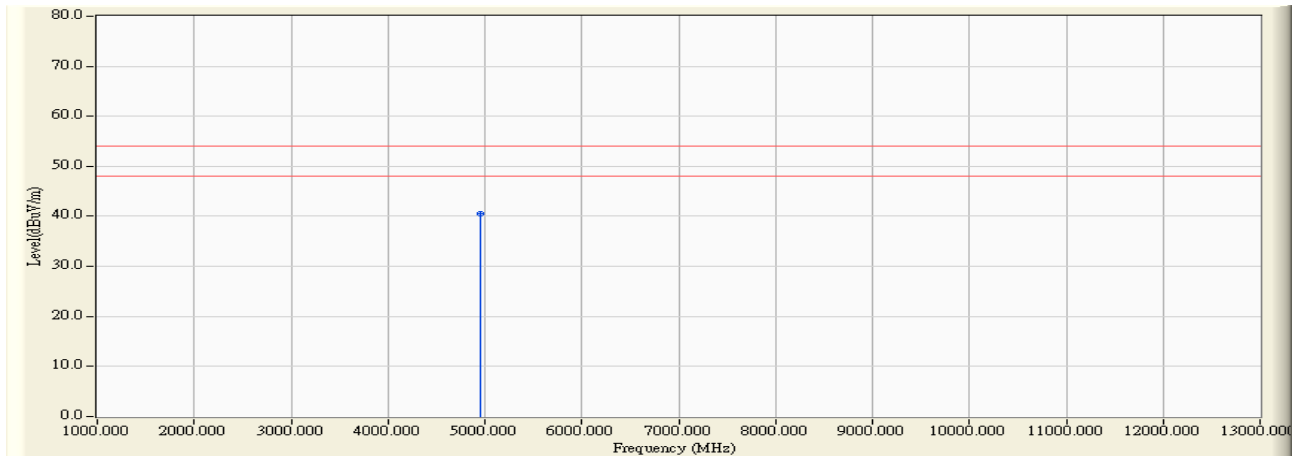

		Frequency (MHz)	Correct Factor (dB)	Reading Level (dBuV)	Measure Level (dBuV/m)	Margin (dB)	Peak Limit (dBuV/m)	Average Limit (dBuV/m)	Detector Type
1	*	4960.100	6.457	34.030	40.487	-13.513	74.000	54.000	AVERAGE

Note:

1. All Readings below 1GHz are average, above are performed with peak and/or average measurements as necessary.
2. “ * ”, means this data is the worst emission level.
3. Measurement Level = Reading Level + Correct Factor.
4. The average measurement was not performed when the peak measured data under the limit of average detection. If the readings given are average, peak measurement should also be supplied.

Engineer :	Time : 2008/04/13 - 12:39
Site : Site 1	Margin : 6
Limit : FCC_SpartC_15.247_H_03M_PK	Probe : CB4_FCC_1-18G(2007) - VERTICAL
EUT : Potable Navigation Device	Power : AC 120V/60Hz
Note : TX-2480MHz	

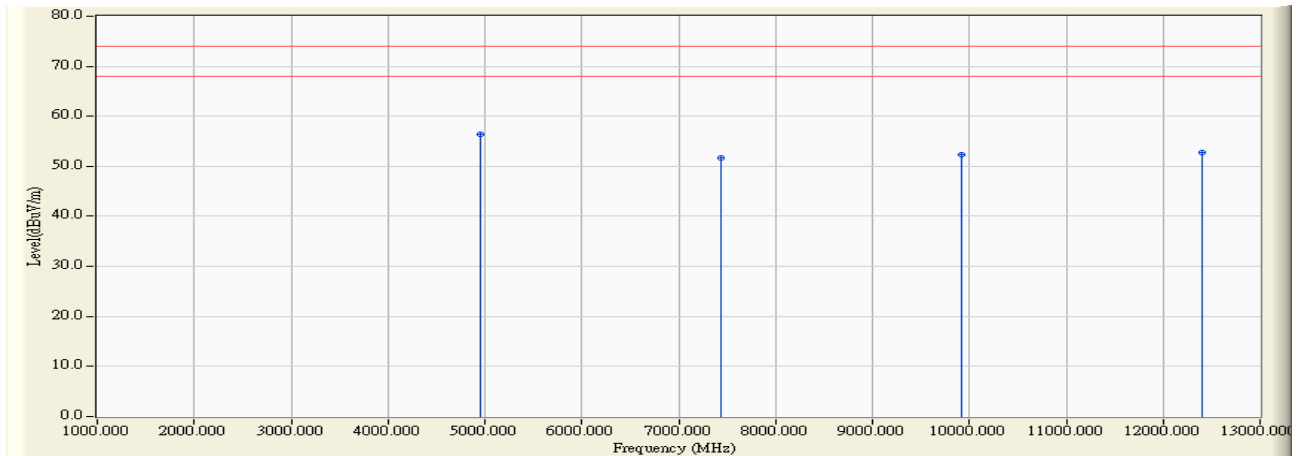

		Frequency (MHz)	Correct Factor (dB)	Reading Level (dBuV)	Measure Level (dBuV/m)	Margin (dB)	Peak Limit (dBuV/m)	Average Limit (dBuV/m)	Detector Type
1	*	4960.060	6.457	49.920	56.377	-17.623	74.000	54.000	PEAK
2		7440.000	14.410	37.180	51.591	-22.409	74.000	54.000	PEAK
3		9919.980	18.205	34.060	52.265	-21.735	74.000	54.000	PEAK
4		12400.020	20.120	32.580	52.700	-21.300	74.000	54.000	PEAK

Note:

1. All Readings below 1GHz are Peak, above are performed with peak and/or average measurements as necessary.
2. “ * ”, means this data is the worst emission level.
3. Measurement Level = Reading Level + Correct Factor.
4. The average measurement was not performed when the peak measured data under the limit of average detection. If the readings given are average, peak measurement should also be supplied.

Engineer :	Time : 2008/04/13 - 12:39
Site : Site 1	Margin : 6
Limit : FCC_SpartC_15.247_H_03M_AV	Probe : CB4_FCC_1-18G(2007) - VERTICAL
EUT : Potable Navigation Device	Power : AC 120V/60Hz
Note : TX-2480MHz	

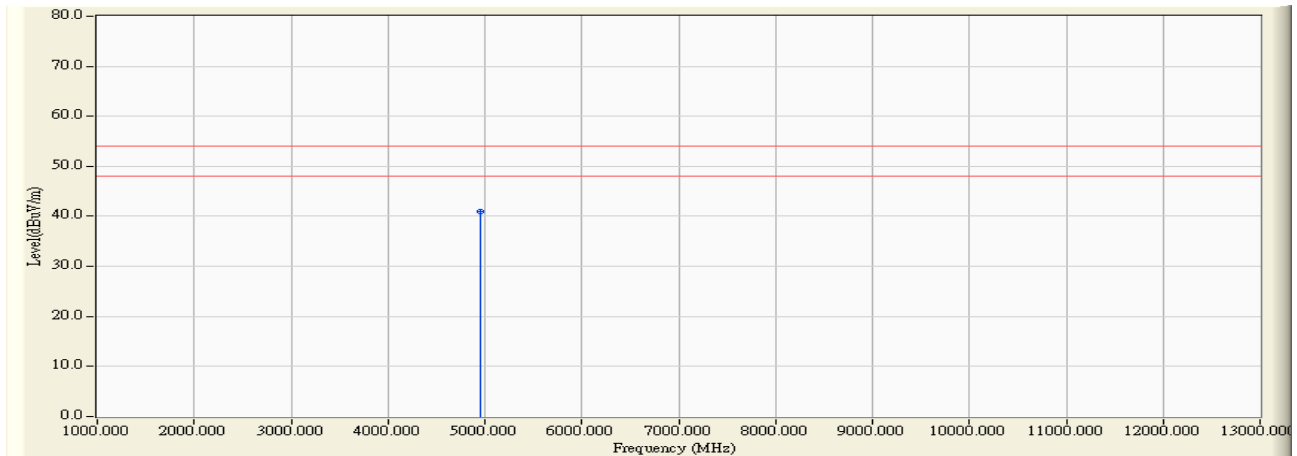

		Frequency (MHz)	Correct Factor (dB)	Reading Level (dBuV)	Measure Level (dBuV/m)	Margin (dB)	Peak Limit (dBuV/m)	Average Limit (dBuV/m)	Detector Type
1	*	4960.040	6.457	34.420	40.877	-13.123	74.000	54.000	AVERAGE

Note:

1. All Readings below 1GHz are average, above are performed with peak and/or average measurements as necessary.
2. “ * ”, means this data is the worst emission level.
3. Measurement Level = Reading Level + Correct Factor.
4. The average measurement was not performed when the peak measured data under the limit of average detection. If the readings given are average, peak measurement should also be supplied.

5. RF Conducted Emission

5.1. Test Equipment

The following test equipments are used during the test:

RF Conducted Measurement:				
Item	Equipment	Manufacturer	Model No. / Serial No.	Last Cal.
1	Spectrum Analyzer	R & S	FSP / 100561	Mar., 2008
2	No.1 OATS			Sep., 2007

Note: 1. All equipments that need to calibrate are with calibration period of 1 year.

2. Mark "X" test instruments are used to measure the final test results.

5.2. Test Setup

RF Conducted Measurement:

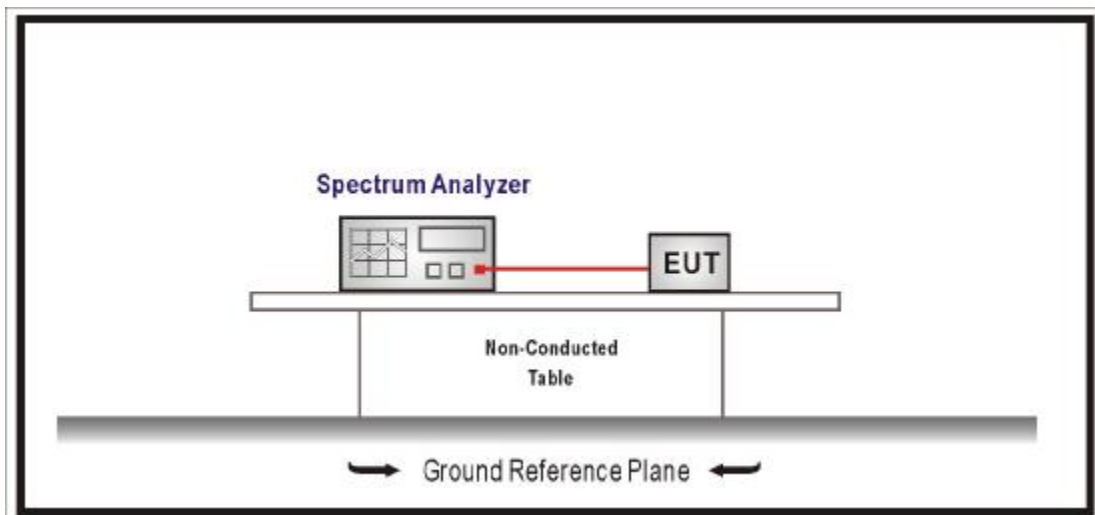

5.3. Limits

In any 100 kHz bandwidth outside the frequency band in which the spread spectrum intentional radiator is operating, the radio frequency power that is produced by the intentional radiator shall be at least 20 dB below that in the 100 kHz bandwidth within the band that contains the highest level of the desired power, based on either an RF conducted or a radiated measurement. Attenuation below the general limits specified in Section 15.209(a) is not required. In addition, radiated emissions which fall in the restricted bands, as defined in Section 15.205(a), must also comply with the radiated emission limits specified in Section 15.209(a) (see Section 15.205(c)).

5.4. Test Procedure

The EUT was setup according to ANSI C63.4, 2003 and tested according to FHSS test procedure of FCC Public Notice DA 00-705 for compliance to FCC 47CFR 15.247 requirements.

5.5. Test Specification

According to FCC Part 15 Subpart C Paragraph 15.247: 2006

5.6. Test Result

Product	Portable Navigation Device		
Test Item	RF Conducted Emissions		
Test Mode	Mode 1: Transmit		
Date of Test	2008/04/28	Test Site	No.1 OATS

Channel No.	Frequency (MHz)	Required Limit (dBc)	Result
00	2402	>20	Pass

Figure Channel 1:

Channel 1

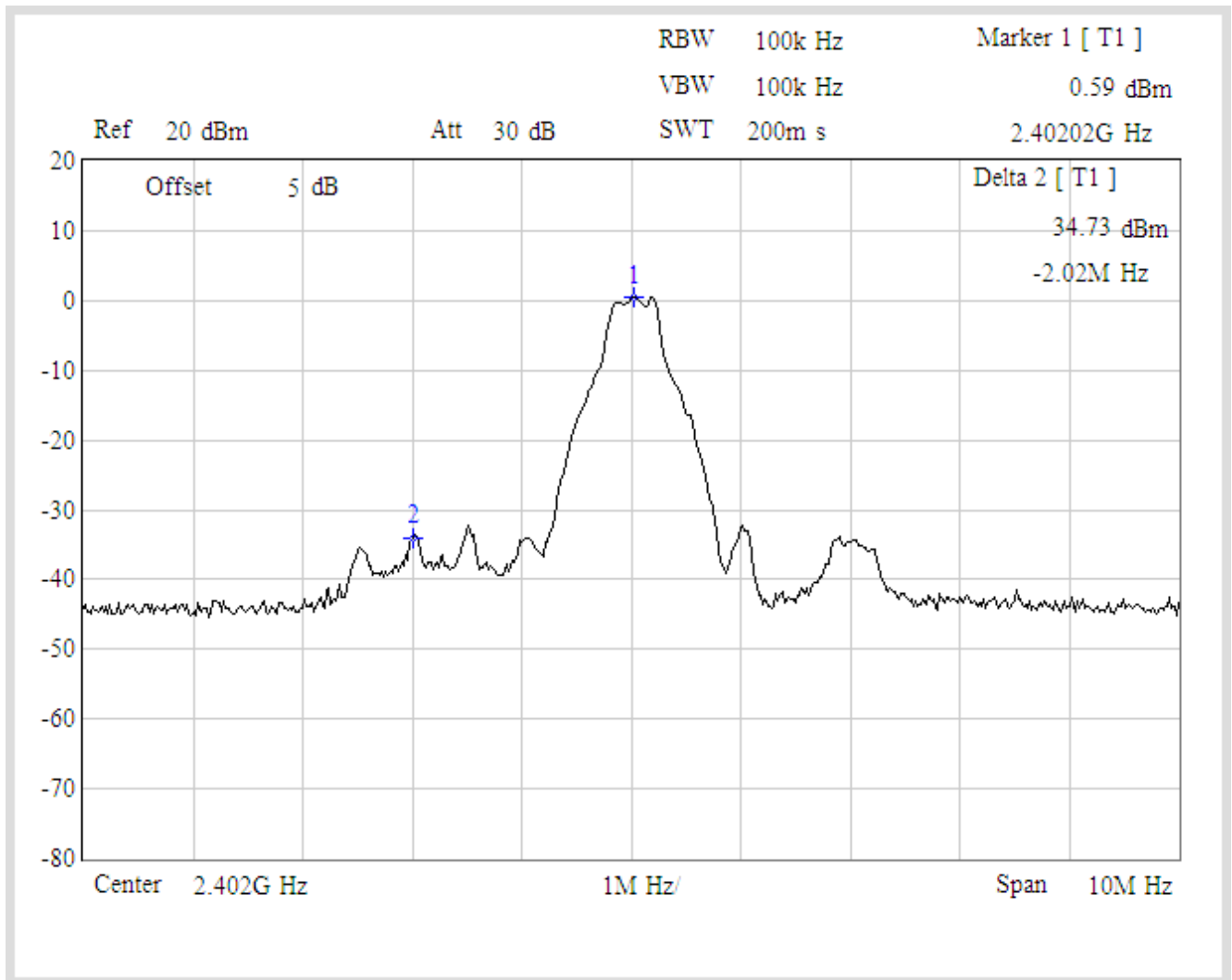

Product	Portable Navigation Device		
Test Item	RF Conducted Emissions		
Test Mode	Mode 1: Transmit		
Date of Test	2008/04/28	Test Site	No.1 OATS

Channel No.	Frequency (MHz)	Required Limit (dBc)	Result
78	2480	>20	Pass

Figure Channel 78:

Channel 78

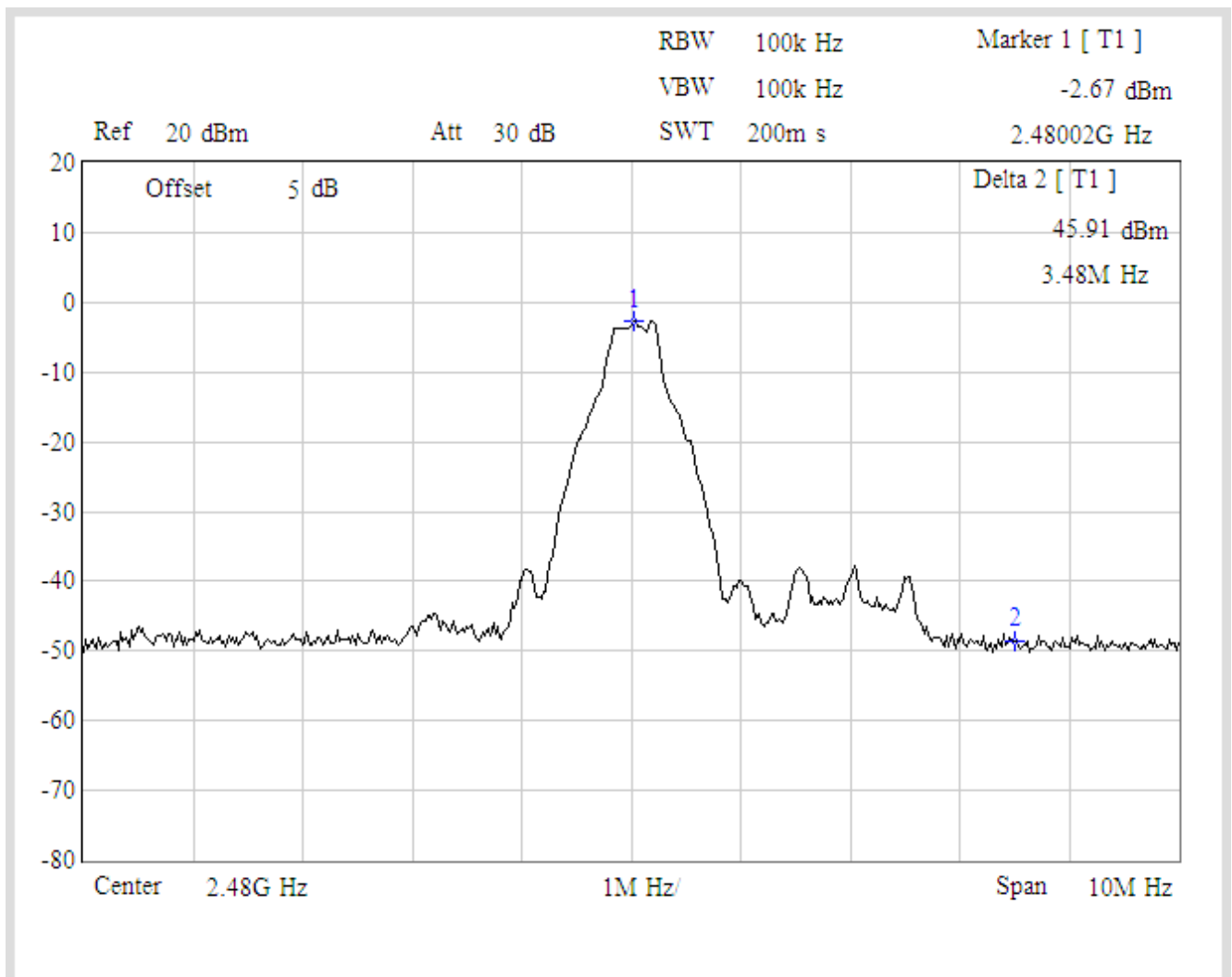

6. Band Edge

6.1. Test Equipment

The following test equipments are used during the test:

RF Radiated Measurement:					
Item		Equipment	Manufacturer	Model No. / Serial No.	Last Cal.
1	X	Spectrum Analyzer	R & S	FSP40 / 100005	Aug., 2007
2	X	Pre-Amplifier	HP	8449B / 3008A01123	Feb., 2008
3		Loop Antenna	R & S	HFH2-Z2 / 833799/004	Sep., 2007
4		BiconiLog Antenna	Schwarzbeck	VULB 9166 / 1061	Sep., 2007
5		Bilog Antenna	Chase	CBL6112B / 2455	Sep., 2007
6	X	Horn Antenna	Schwarzbeck	BBHA 9120D / BBHA9120D312	Sep., 2007
7		No.1 OATS			Sep., 2007

- Note: 1. All equipments that need to calibrate are with calibration period of 1 year.
 2. Mark "X" test instruments are used to measure the final test results.

6.2. Test Setup

RF Radiated Measurement:

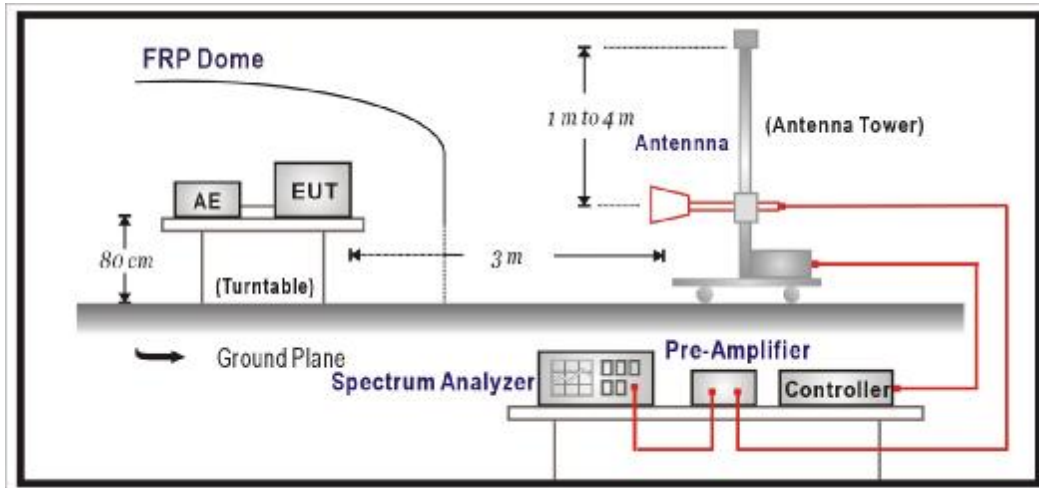

6.3. Limits

Emissions radiated outside of the specified frequency bands, except for harmonics, shall be attenuated by at least 20dB below the level of the fundamental or to the general radiated emission limits in paragraph 15.209, whichever is the lesser attenuation.

6.4. Test Procedure

The EUT was setup according to ANSI C63.4, 2003 and tested according to FHSS test procedure of FCC Public Notice DA 00-705 for compliance to FCC 47CFR 15.247 requirements

The EUT and its simulators are placed on a turn table which is 0.8 meter above ground. The turn table can rotate 360 degrees to determine the position of the maximum emission level. The EUT was positioned such that the distance from antenna to the EUT was 3 meters.

The antenna can move up and down between 1 meter and 4 meters to find out the maximum emission level.

Both horizontal and vertical polarization of the antenna are set on measurement. In order to find the maximum emission, all of the interface cables must be manipulated according to ANSI C63.4:2003 on radiated measurement.

6.5. Test Specification

According to FCC Part 15 Subpart C Paragraph 15.247: 2006

6.6. Test Result

Engineer :	Time : 2008/04/22 - 10:20
Site : Site 1	Margin : 6
Limit : FCC_15.209(961011)_03M_PK	Probe : CB3_FCC_1-18G(2007) - HORIZONTAL
EUT : Portable Navigation Device	
Power : AC 120V/60Hz	
Note : TX-2402	

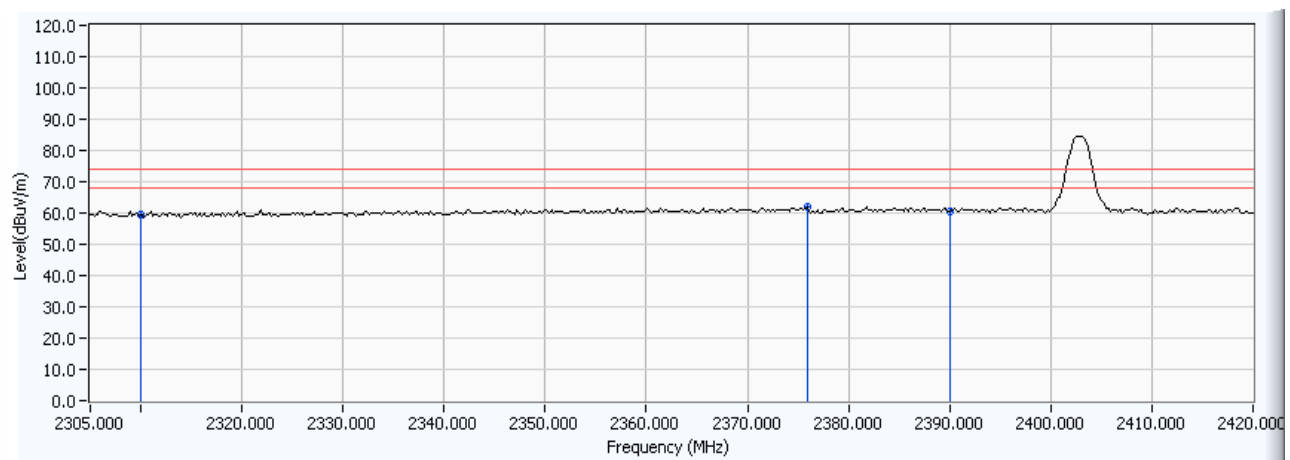

	Frequency (MHz)	Correct Factor (dB)	Reading Level (dBuV)	Measure Level (dBuV/m)	Margin (dB)	Limit (dBuV/m)	Detector Type
1	2310.000	30.412	28.956	59.367	-14.633	74.000	PEAK
2	* 2375.982	30.518	31.499	62.017	-11.983	74.000	PEAK
3	2390.000	30.543	30.077	60.620	-13.380	74.000	PEAK

Note:

1. All Readings below 1GHz are peak, above are performed with peak and/or average measurements as necessary.
2. “ * ”, means this data is the worst emission level.
3. Measurement Level = Reading Level + Correct Factor.
4. The average measurement was not performed when the peak measured data under the limit of average detection. If the readings given are average, peak measurement should also be supplied.

Engineer :	Time : 2008/04/22 - 10:40
Site : Site 1	Margin : 6
Limit : FCC_15.209(961011)_03M_PK	Probe : CB3_FCC_1-18G(2007) - VERTICAL
EUT : Portable Navigation Device	
Power : AC 120V/60Hz	
Note : TX-2402	

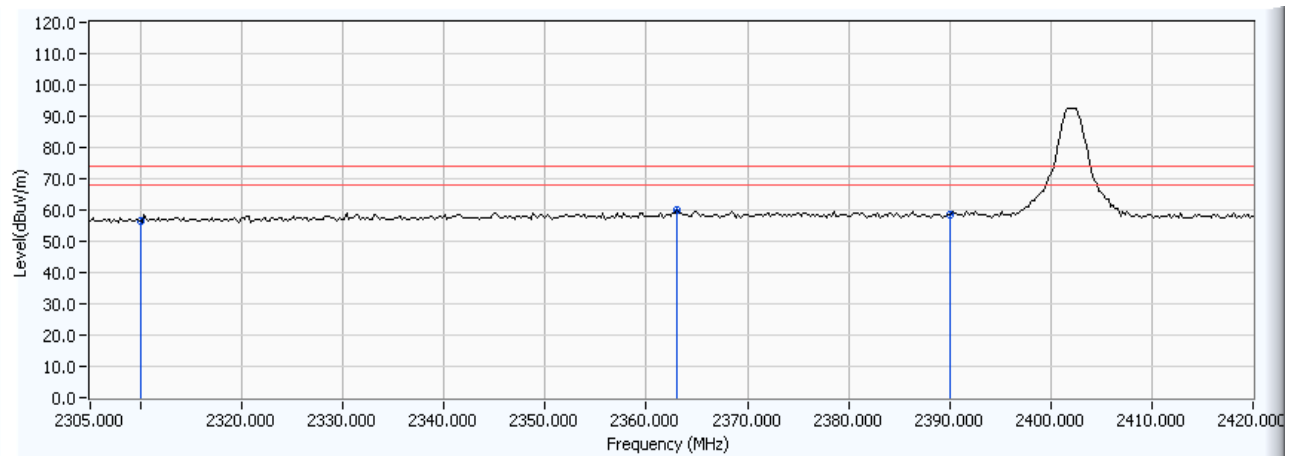

	Frequency (MHz)	Correct Factor (dB)	Reading Level (dBuV)	Measure Level (dBuV/m)	Margin (dB)	Limit (dBuV/m)	Detector Type
1	2310.000	28.433	27.951	56.384	-17.616	74.000	PEAK
2	* 2363.076	28.621	31.178	59.799	-14.201	74.000	PEAK
3	2390.000	28.724	29.785	58.509	-15.491	74.000	PEAK

Note:

1. All Readings below 1GHz are peak, above are performed with peak and/or average measurements as necessary.
2. “ * ”, means this data is the worst emission level.
3. Measurement Level = Reading Level + Correct Factor.
4. The average measurement was not performed when the peak measured data under the limit of average detection. If the readings given are average, peak measurement should also be supplied.

Engineer :	Time : 2008/04/22 - 11:14
Site : Site 1	Margin : 6
Limit : FCC_15.209(961011)_03M_AV	Probe : CB3_FCC_1-18G(2007) - HORIZONTAL
EUT : Portable Navigation Device	
Power : AC 120V/60Hz	
Note : TX-2402	

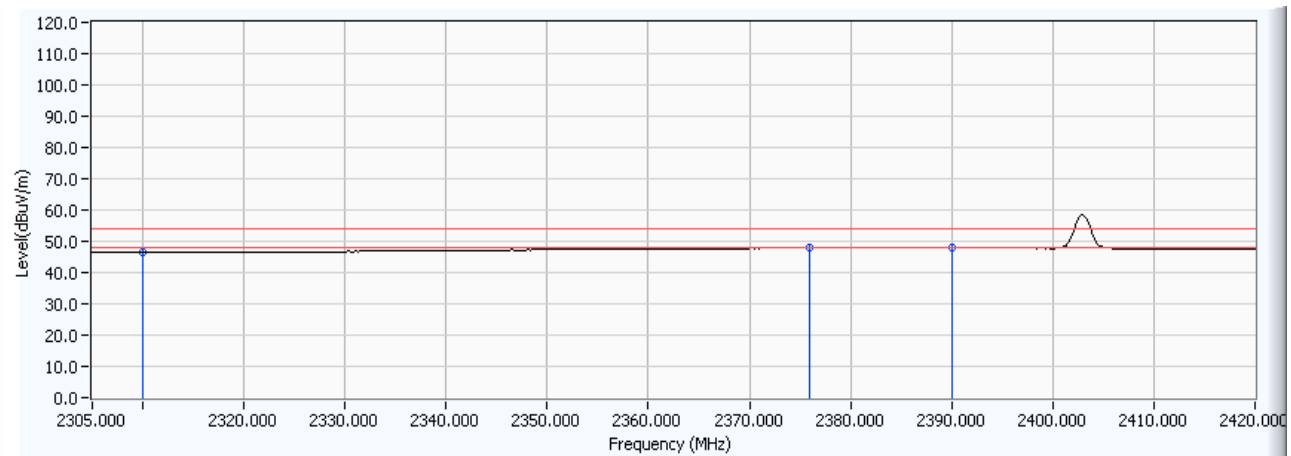

	Frequency (MHz)	Correct Factor (dB)	Reading Level (dBuV)	Measure Level (dBuV/m)	Margin (dB)	Limit (dBuV/m)	Detector Type
1	2310.000	30.412	15.959	46.370	-7.630	54.000	AVERAGE
2	* 2375.982	30.518	17.294	47.812	-6.188	54.000	AVERAGE
3	2390.000	30.543	17.257	47.800	-6.200	54.000	AVERAGE

Note:

1. All Readings below 1GHz are average, above are performed with peak and/or average measurements as necessary.
2. “ * ”, means this data is the worst emission level.
3. Measurement Level = Reading Level + Correct Factor.
4. The average measurement was not performed when the peak measured data under the limit of average detection. If the readings given are average, peak measurement should also be supplied.

Engineer :	Time : 2008/04/22 - 10:42
Site : Site 1	Margin : 6
Limit : FCC_15.209(961011)_03M_AV	Probe : CB3_FCC_1-18G(2007) - VERTICAL
EUT : Portable Navigation Device	
Power : AC 120V/60Hz	
Note : TX-2402	

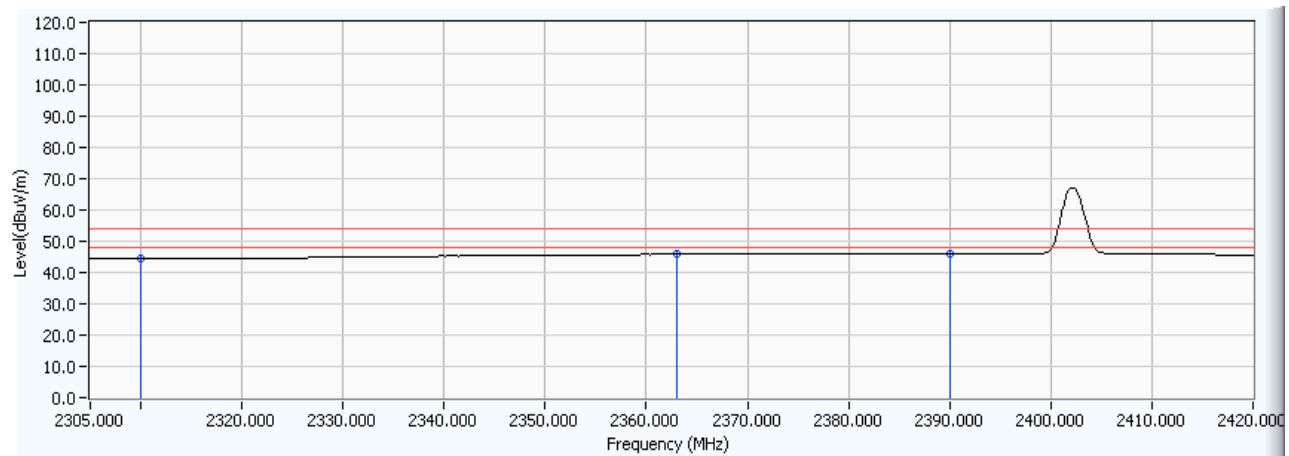

	Frequency (MHz)	Correct Factor (dB)	Reading Level (dBuV)	Measure Level (dBuV/m)	Margin (dB)	Limit (dBuV/m)	Detector Type
1	2310.000	28.433	16.023	44.456	-9.544	54.000	AVERAGE
2	2363.076	28.621	17.167	45.788	-8.212	54.000	AVERAGE
3	* 2390.000	28.724	17.263	45.987	-8.013	54.000	AVERAGE

Note:

1. All Readings below 1GHz are average, above are performed with peak and/or average measurements as necessary.
2. “ * ”, means this data is the worst emission level.
3. Measurement Level = Reading Level + Correct Factor.
4. The average measurement was not performed when the peak measured data under the limit of average detection. If the readings given are average, peak measurement should also be supplied.

Engineer :	Time : 2008/04/22 - 10:52
Site : Site 1	Margin : 6
Limit : FCC_15.209(961011)_03M_PK	Probe : CB3_FCC_1-18G(2007) - HORIZONTAL
EUT : Portable Navigation Device	
Power : AC 120V/60Hz	
Note : TX-2480	

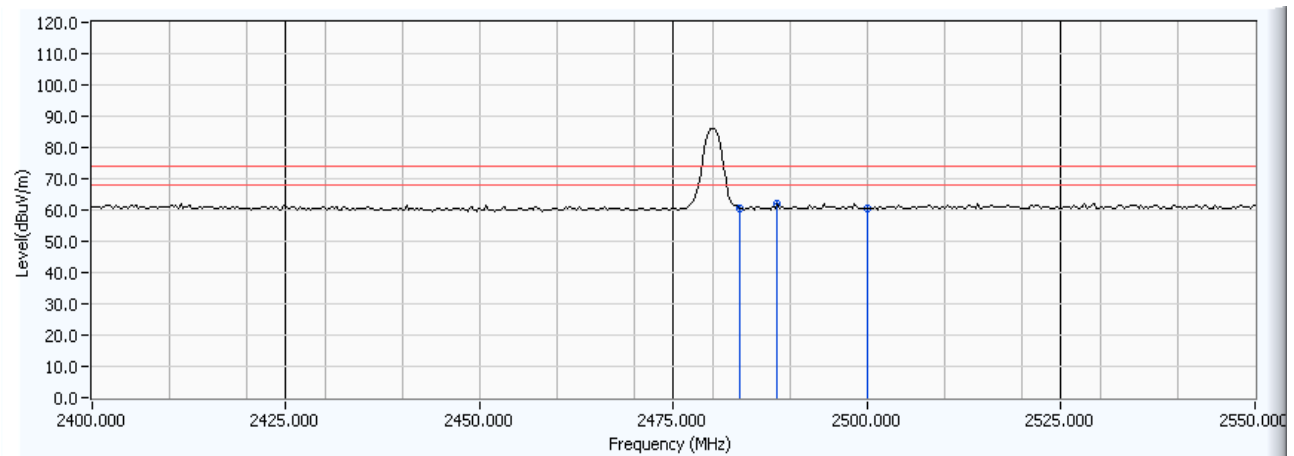

		Frequency (MHz)	Correct Factor (dB)	Reading Level (dBuV)	Measure Level (dBuV/m)	Margin (dB)	Limit (dBuV/m)	Detector Type
1		2483.500	30.696	29.796	60.491	-13.509	74.000	PEAK
2	*	2488.377	30.702	31.240	61.941	-12.059	74.000	PEAK
3		2500.000	30.722	29.946	60.668	-13.332	74.000	PEAK

Note:

1. All Readings below 1GHz are Peak, above are performed with peak and/or average measurements as necessary.
2. “ * ”, means this data is the worst emission level.
3. Measurement Level = Reading Level + Correct Factor.
4. The average measurement was not performed when the peak measured data under the limit of average detection. If the readings given are average, peak measurement should also be supplied.

Engineer :	Time : 2008/04/22 - 10:59
Site : Site 1	Margin : 6
Limit : FCC_15.209(961011)_03M_PK	Probe : CB3_FCC_1-18G(2007) - VERTICAL
EUT : Portable Navigation Device	
Power : AC 120V/60Hz	
Note : TX-2480	

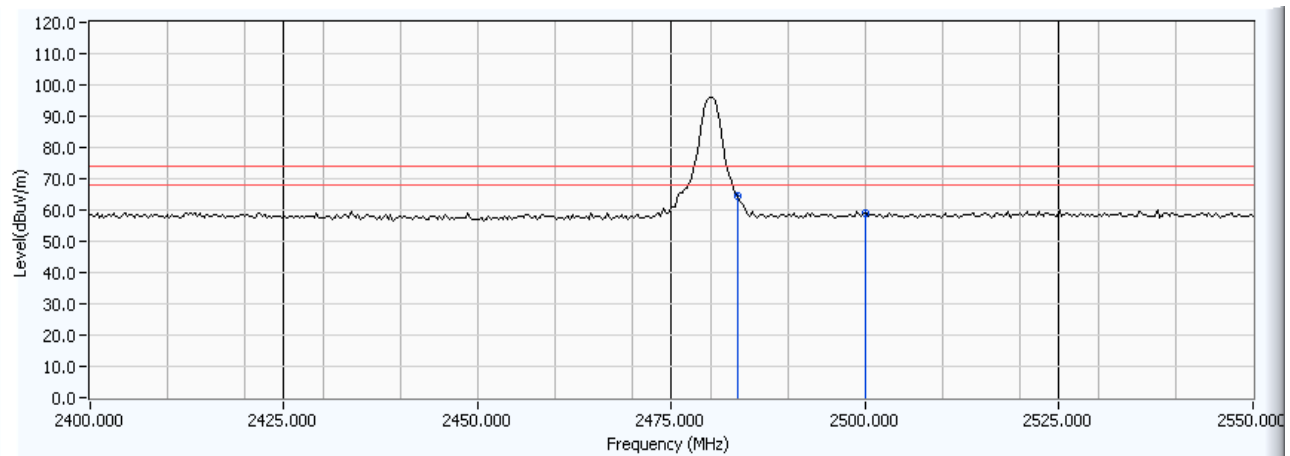

		Frequency (MHz)	Correct Factor (dB)	Reading Level (dBuV)	Measure Level (dBuV/m)	Margin (dB)	Limit (dBuV/m)	Detector Type
1	*	2483.500	29.064	35.329	64.392	-9.608	74.000	PEAK
2		2483.567	29.064	35.203	64.266	-9.734	74.000	PEAK
3		2500.000	29.114	29.744	58.858	-15.142	74.000	PEAK

Note:

1. All Readings below 1GHz are Peak, above are performed with peak and/or average measurements as necessary.
2. “ * ”, means this data is the worst emission level.
3. Measurement Level = Reading Level + Correct Factor.
4. The average measurement was not performed when the peak measured data under the limit of average detection. If the readings given are average, peak measurement should also be supplied.

Engineer :	Time : 2008/04/22 - 10:54
Site : Site 1	Margin : 6
Limit : FCC_15.209(961011)_03M_AV	Probe : CB3_FCC_1-18G(2007) - HORIZONTAL
EUT : Portable Navigation Device	
Power : AC 120V/60Hz	
Note : TX-2480	

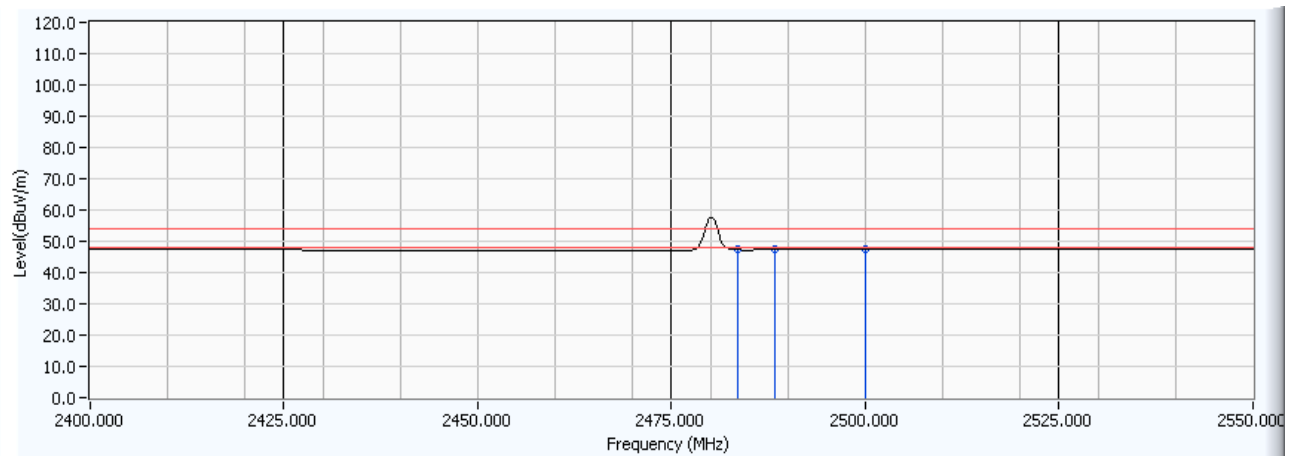

	Frequency (MHz)	Correct Factor (dB)	Reading Level (dBuV)	Measure Level (dBuV/m)	Margin (dB)	Limit (dBuV/m)	Detector Type
1	2483.500	30.696	16.568	47.263	-6.737	54.000	AVERAGE
2	2488.377	30.702	16.641	47.342	-6.658	54.000	AVERAGE
3	* 2500.000	30.722	16.753	47.475	-6.525	54.000	AVERAGE

Note:

1. All Readings below 1GHz are average, above are performed with peak and/or average measurements as necessary.
2. “ * ”, means this data is the worst emission level.
3. Measurement Level = Reading Level + Correct Factor.
4. The average measurement was not performed when the peak measured data under the limit of average detection. If the readings given are average, peak measurement should also be supplied.

Engineer :	Time : 2008/04/22 - 11:02
Site : Site 1	Margin : 6
Limit : FCC_15.209(961011)_03M_AV	Probe : CB3_FCC_1-18G(2007) - VERTICAL
EUT : Portable Navigation Device	
Power : AC 120V/60Hz	
Note : TX-2480	

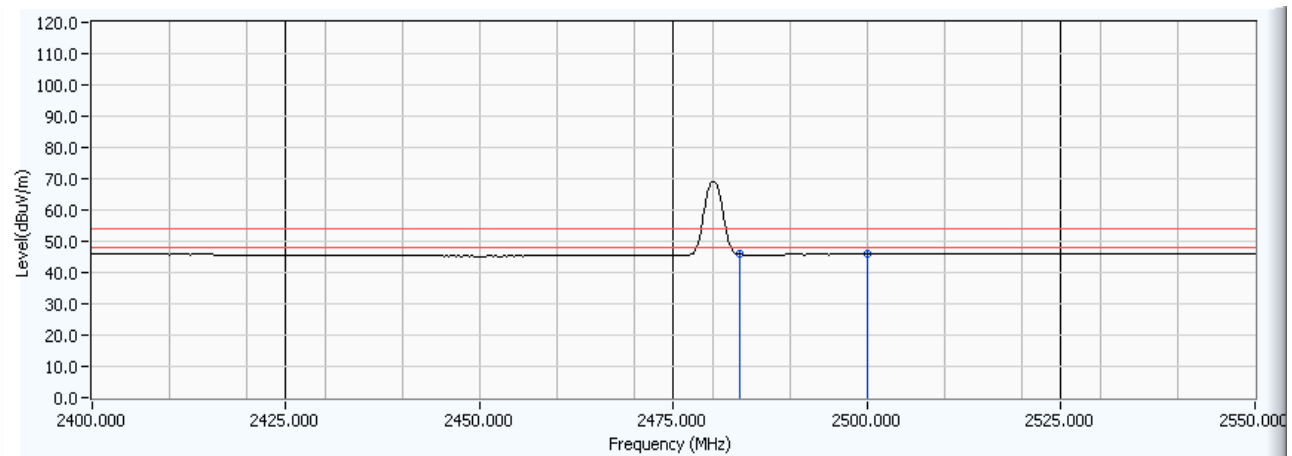

	Frequency (MHz)	Correct Factor (dB)	Reading Level (dBuV)	Measure Level (dBuV/m)	Margin (dB)	Limit (dBuV/m)	Detector Type
1	2483.500	29.064	16.728	45.791	-8.209	54.000	AVERAGE
2	2483.567	29.064	16.694	45.757	-8.243	54.000	AVERAGE
3	* 2500.000	29.114	16.761	45.875	-8.125	54.000	AVERAGE

Note:

1. All Readings below 1GHz are average, above are performed with peak and/or average measurements as necessary.
2. “ * ”, means this data is the worst emission level.
3. Measurement Level = Reading Level + Correct Factor.
4. The average measurement was not performed when the peak measured data under the limit of average detection. If the readings given are average, peak measurement should also be supplied.

7. Number of hopping frequency

7.1. Test Equipment

The following test equipments are used during the test:

Item	Equipment	Manufacturer	Model No. / Serial No.	Last Cal.
1	Spectrum Analyzer	R & S	FSP / 100561	Mar., 2008
2	No.1 OATS			Sep., 2007

Note: 1. All equipments that need to calibrate are with calibration period of 1 year.

7.2. Test Setup

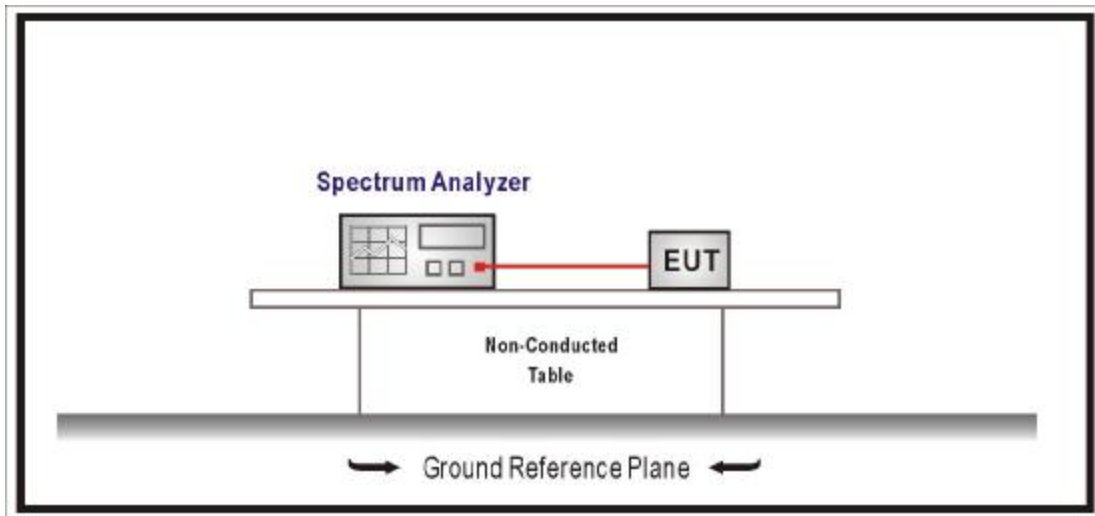

7.3. Limits

For frequency hopping systems operating in the 902-928 MHz band: if the 20 dB bandwidth of the hopping channel is less than 250 kHz, the system shall use at least 50 hopping frequencies and the average time of occupancy on any frequency shall not be greater than 0.4 seconds within a 20 second period; if the 20 dB bandwidth of the hopping channel is 250 kHz or greater, the system shall use at least 25 hopping frequencies and the average time of occupancy on any frequency shall not be greater than 0.4 seconds within a 10 second period. The maximum allowed 20 dB bandwidth of the hopping channel is 500 kHz.

For frequency hopping systems operating in the 2400-2483.5 MHz bands, which use fewer than 75 hopping frequencies, may employ intelligent hopping techniques to avoid interference to other transmissions. Frequency hopping systems may avoid or suppress transmissions on a particular hopping frequency provided that a minimum of 15 non-overlapping channels are used.

For frequency hopping systems operating in the 5725-5850 MHz band shall use at least 75 hopping frequencies.

7.4. Test Procedures

The EUT was setup according to ANSI C63.4, 2003 and tested according to FHSS test procedure of FCC Public Notice DA 00-705 for compliance to FCC 47CFR 15.247 requirements

Span = the frequency band of operation

RBW \geq 1% of the span , VBW \geq RBW

Sweep = auto, Detector function = peak, Trace = max hold

7.5. Test Specification

According to FCC Part 15 Subpart C Paragraph 15.247: 2006

7.6. Test Result

Product	Portable Navigation Device		
Test Item	Number of hopping frequency		
Test Mode	Transmit		
Date of Test	2008/04/28	Test Site	No.1 OATS

Frequency Range (MHz)	Measure Level (Hopping Channel)	Limit (Hopping Channel)	Result
2402 ~ 2480	79	>75	Pass

2402-2420MHz

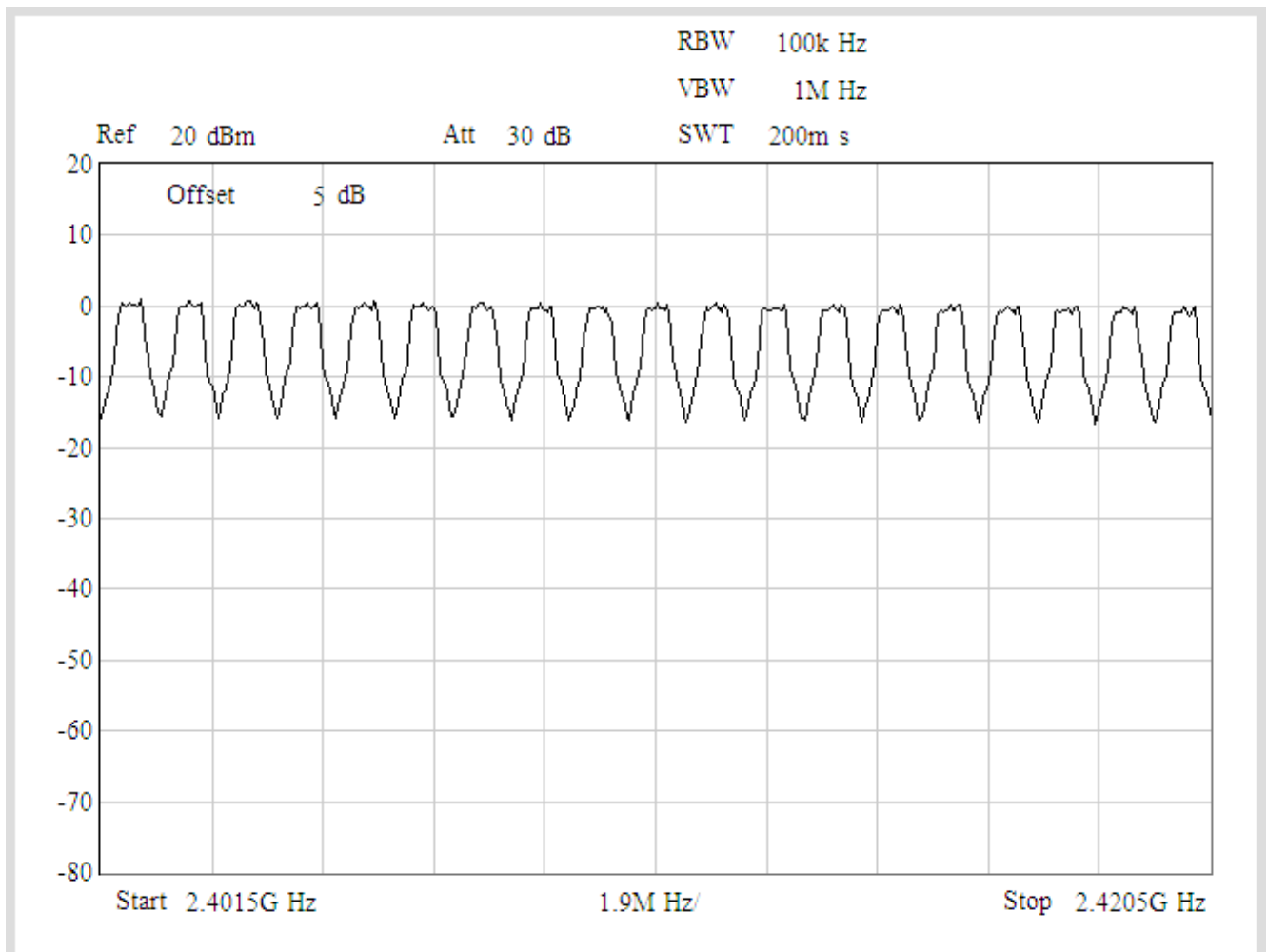

2421-2440MHz

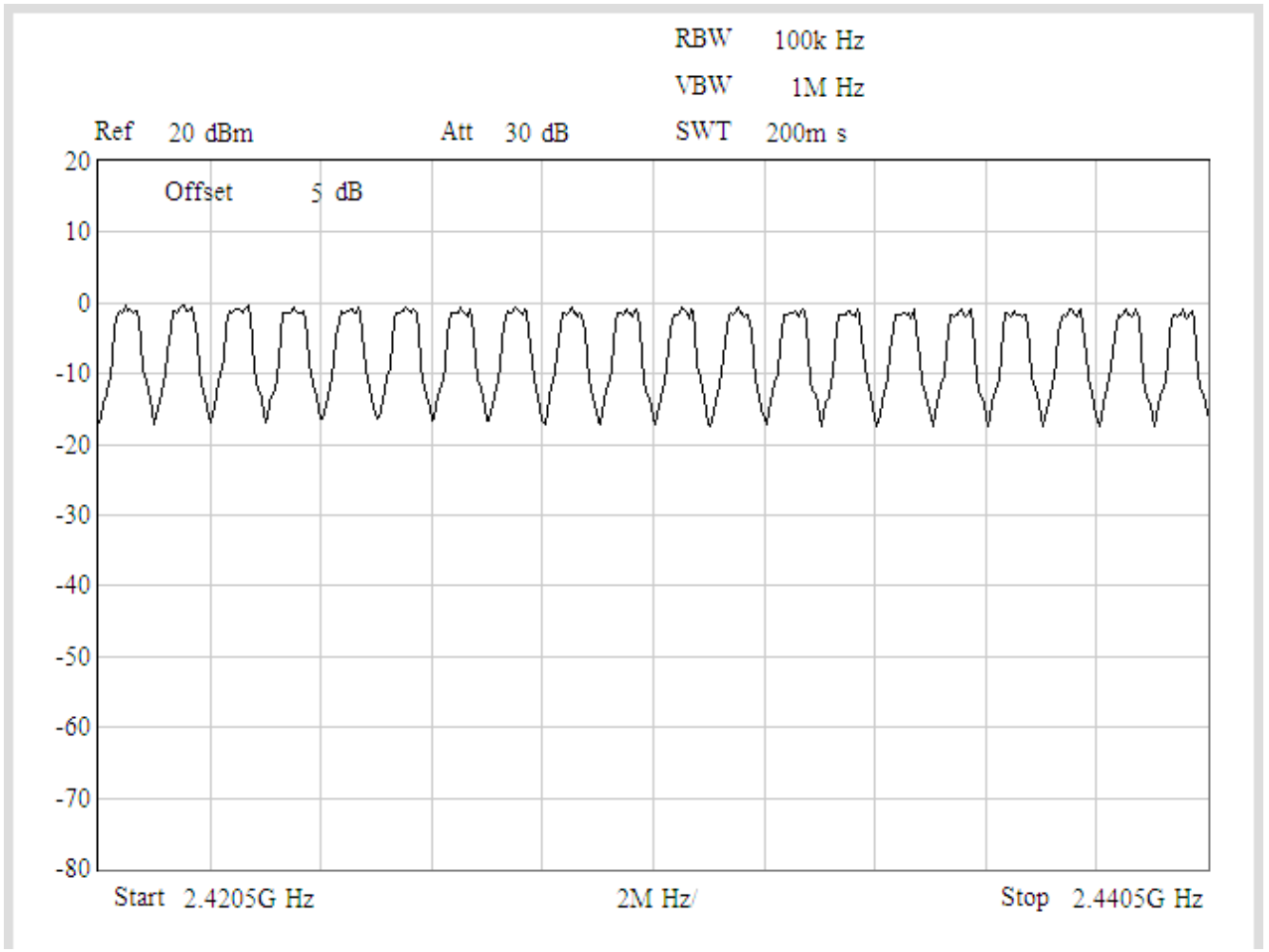

2441-2460MHz

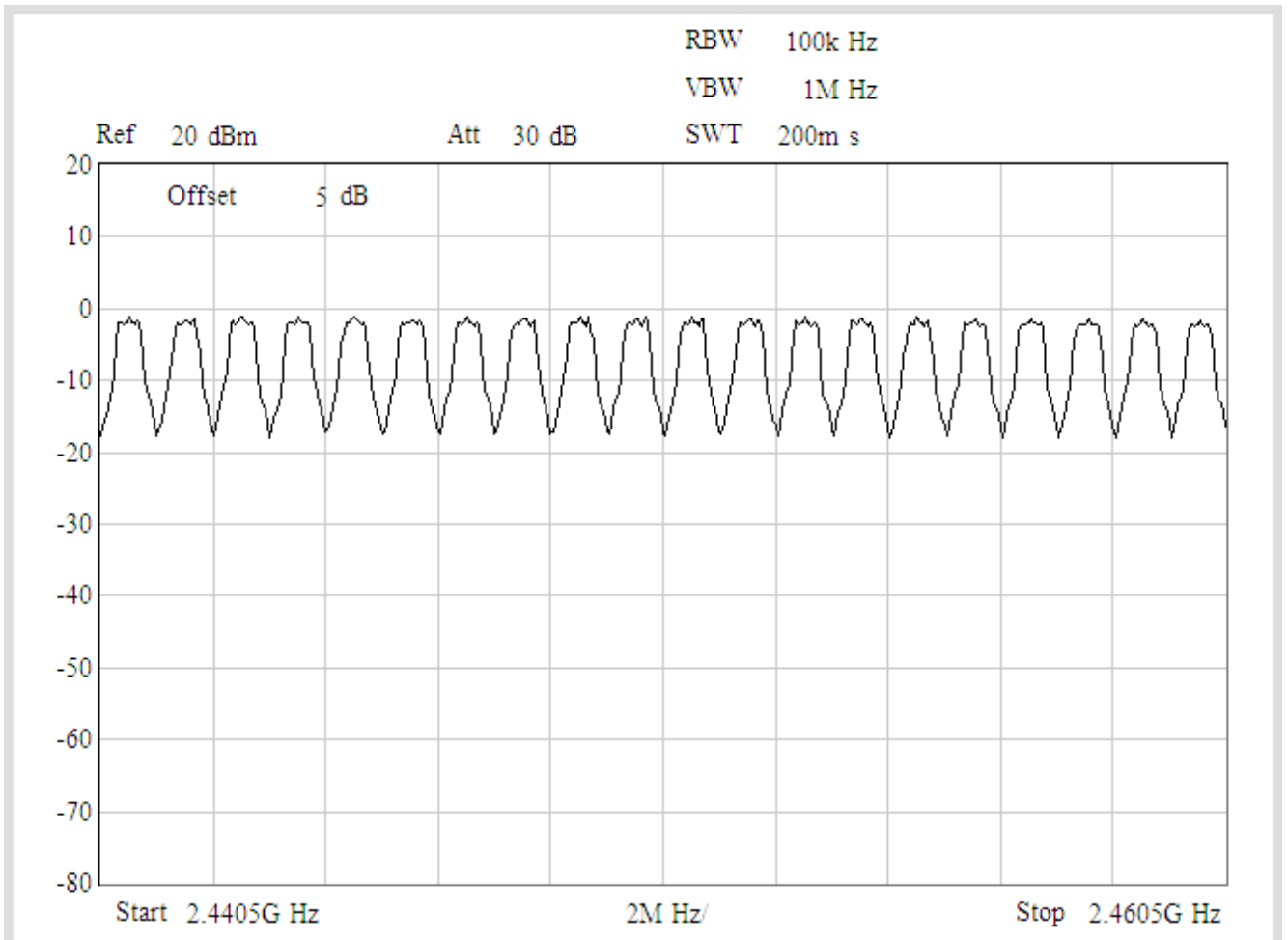

2461-2480MHz

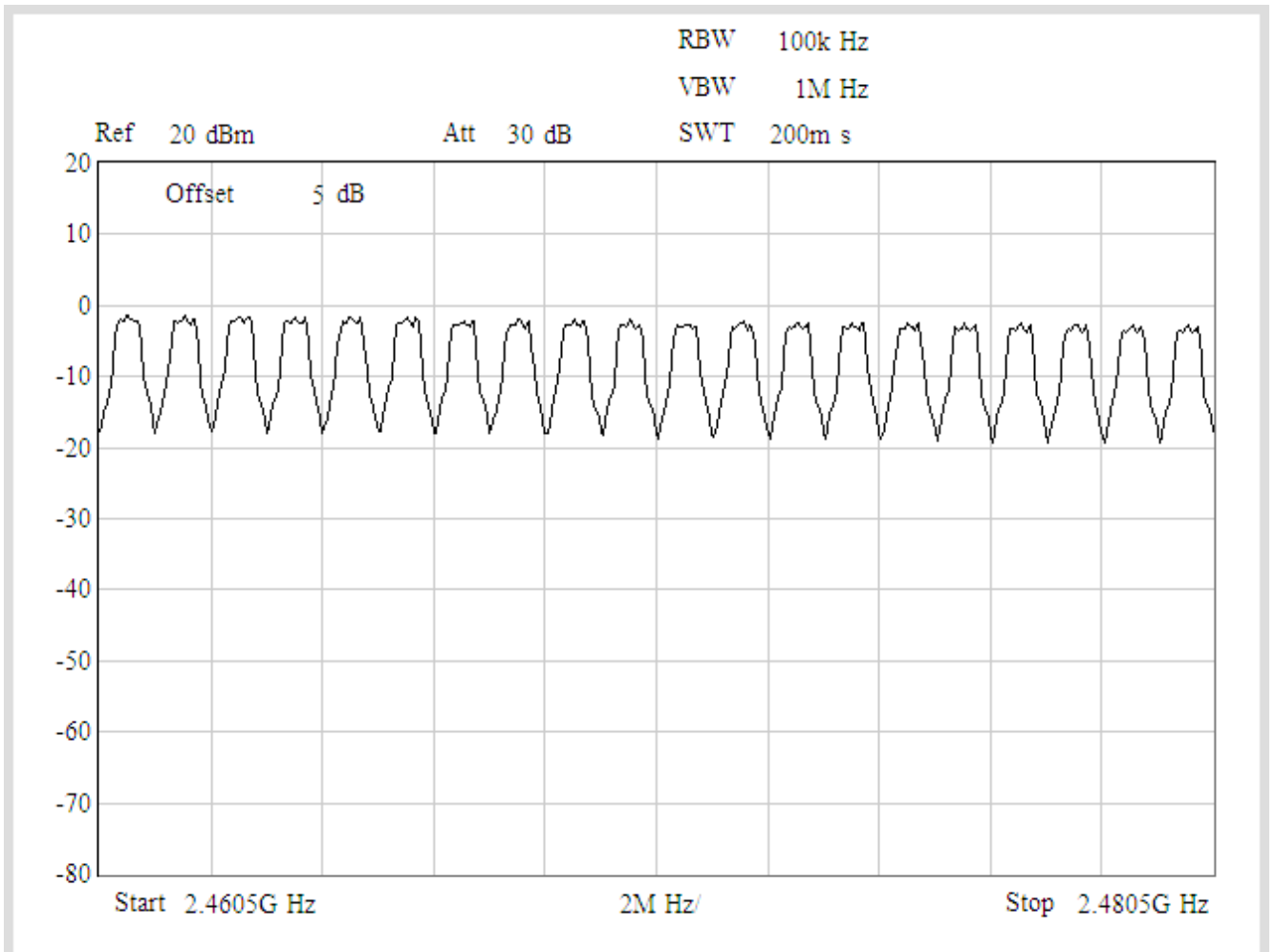

8. Carrier Frequency Separation

8.1. Test Equipment

The following test equipment are used during the test:

Item	Equipment	Manufacturer	Model No. / Serial No.	Last Cal.
1	Spectrum Analyzer	R & S	FSP / 100561	Mar., 2008
2	No.1 OATS			Sep., 2007

Note: 1. All equipments that need to calibrate are with calibration period of 1 year.

8.2. Test Setup

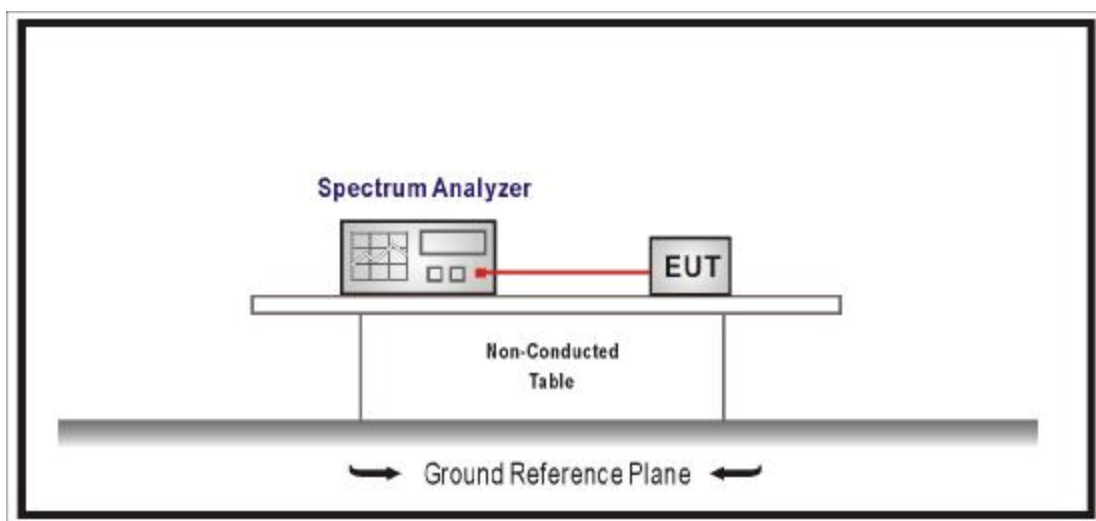

8.3. Limits

For frequency hopping systems shall have hopping channel carrier frequencies separated by a minimum of 25 kHz or the 20 dB bandwidth of the hopping channel, whichever is greater.

8.4. Test Procedures

The EUT was setup according to ANSI C63.4, 2003 and tested according to FHSS test procedure of FCC Public Notice DA 00-705 for compliance to FCC 47CFR 15.247 requirements

Span = wide enough to capture the peaks of two adjacent channels

Resolution Bandwidth (RBW) \geq 1% of the span, VBW \geq RBW

Sweep = auto, Detector function = peak, Trace = max hold

8.5. Test Specification

According to FCC Part 15 Subpart C Paragraph 15.247: 2006

Product	Portable Navigation Device		
Test Item	Carrier Frequency Separation		
Test Mode	Transmit		
Date of Test	2008/03/28	Test Site	No.1 OATS

Channel No.	Frequency (MHz)	Measure Level (kHz)	Limit (kHz)	Result
39	2441.00	1000	>739.86	Pass

Channel 39

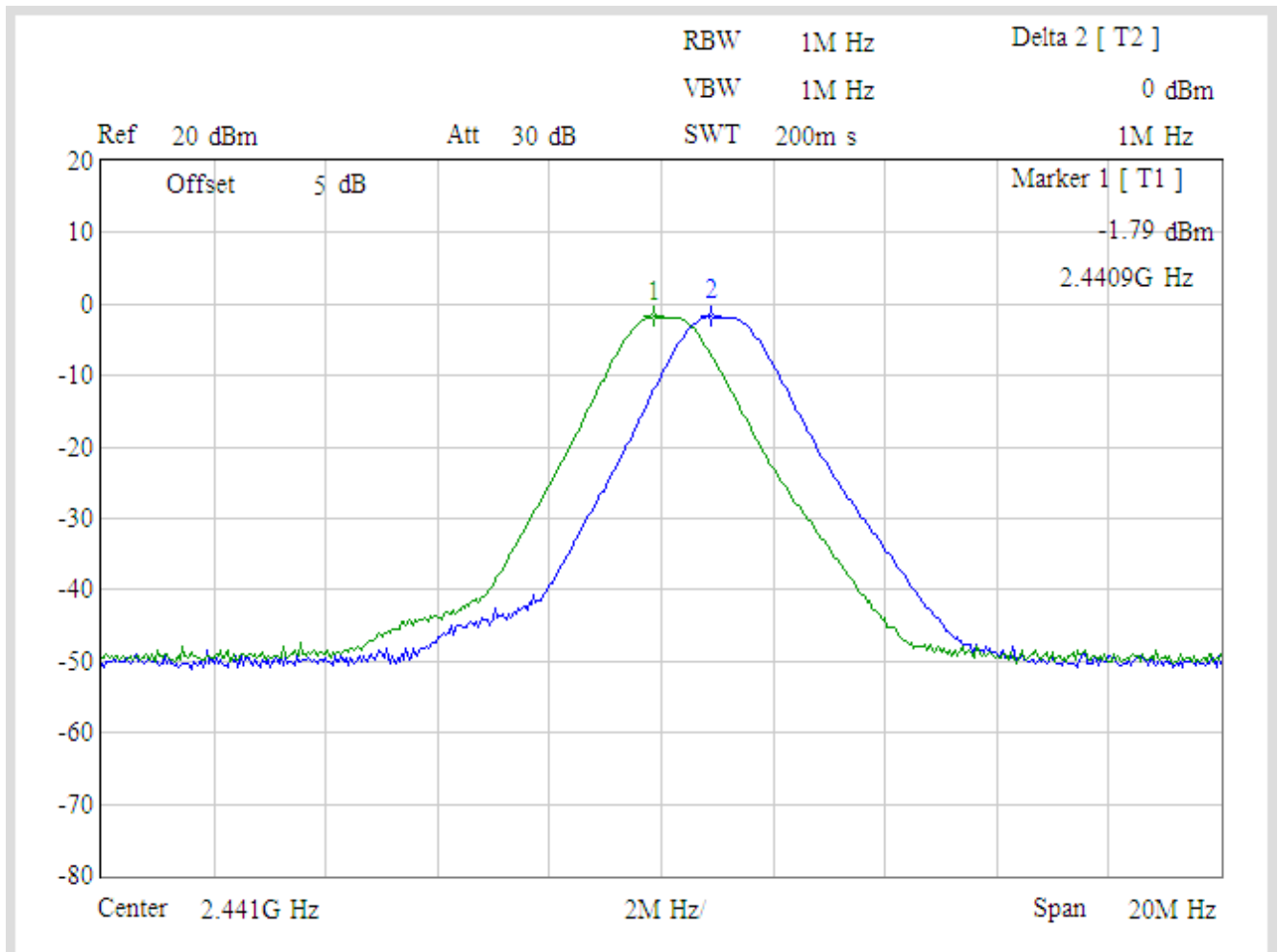

9. Occupied Bandwidth

9.1. Test Equipment

The following test equipment are used during the test:

Item	Equipment	Manufacturer	Model No. / Serial No.	Last Cal.
1	Spectrum Analyzer	R & S	FSP / 100561	Mar., 2008
2	No.1 OATS			Sep., 2007

Note: 1. All equipments that need to calibrate are with calibration period of 1 year.

9.2. Test Setup

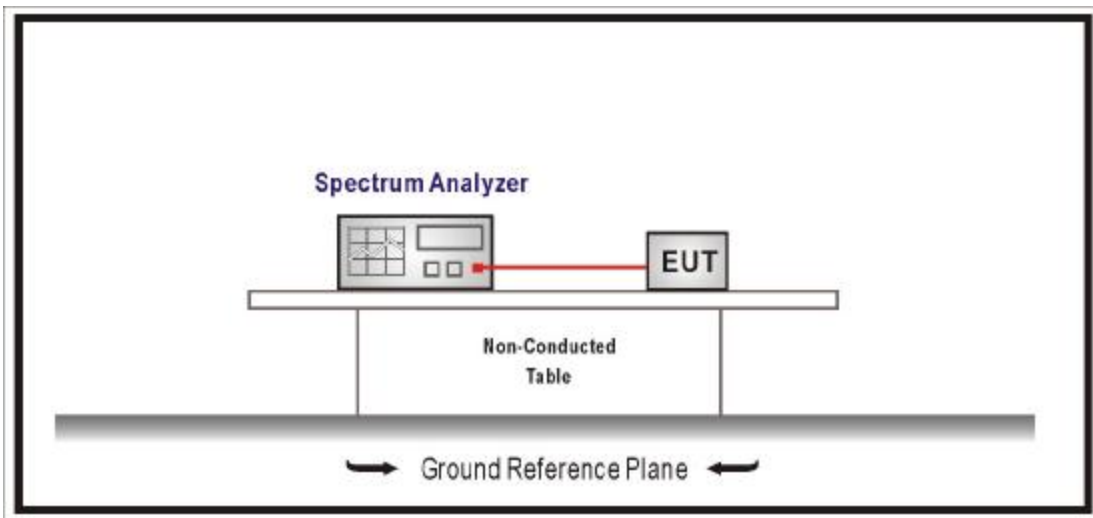

9.3. Limits

For frequency hopping systems operating in the 902-928 MHz band: if the 20 dB bandwidth of the hopping channel is less than 250 kHz, the system shall use at least 50 hopping frequencies and the average time of occupancy on any frequency shall not be greater than 0.4 seconds within a 20 second period; if the 20 dB bandwidth of the hopping channel is 250 kHz or greater, the system shall use at least 25 hopping frequencies and the average time of occupancy on any frequency shall not be greater than 0.4 seconds within a 10 second period. The maximum allowed 20 dB bandwidth of the hopping channel is 500 kHz.

For frequency hopping systems operating in the 5725-5850 MHz bands. The maximum 20 dB bandwidth of the hopping channel is 1 MHz.

For frequency hopping systems shall have hopping channel carrier frequencies separated by a minimum of 25 kHz or the 20 dB bandwidth of the hopping channel, whichever is greater.

9.4. Test Procedures

The EUT was setup according to ANSI C63.4, 2003 and tested according to FHSS test procedure of FCC Public Notice DA 00-705 for compliance to FCC 47CFR 15.247 requirements

Use the following spectrum analyzer settings:

Span = approximately 2 to 3 times the 20 dB bandwidth, centered on a hopping channel

RBW \geq 1% of the 20 dB bandwidth, VBW \geq RBW

Sweep = auto, Detector function = peak, Trace = max hold

The EUT should be transmitting at its maximum data rate.

9.5. Test Specification

According to FCC Part 15 Subpart C Paragraph 15.247: 2006

9.6. Test Result

Product	Portable Navigation Device		
Test Item	Occupied Bandwidth		
Test Mode	Transmit		
Date of Test	2008/03/28	Test Site	No.1 OATS

1M-GFSK Modulation, PRBS Packet Type

Channel No.	Frequency (MHz)	Measure Level (MHz)	Limit (MHz)	Result
00	2402.00	1.121	--	Pass

Channel 00

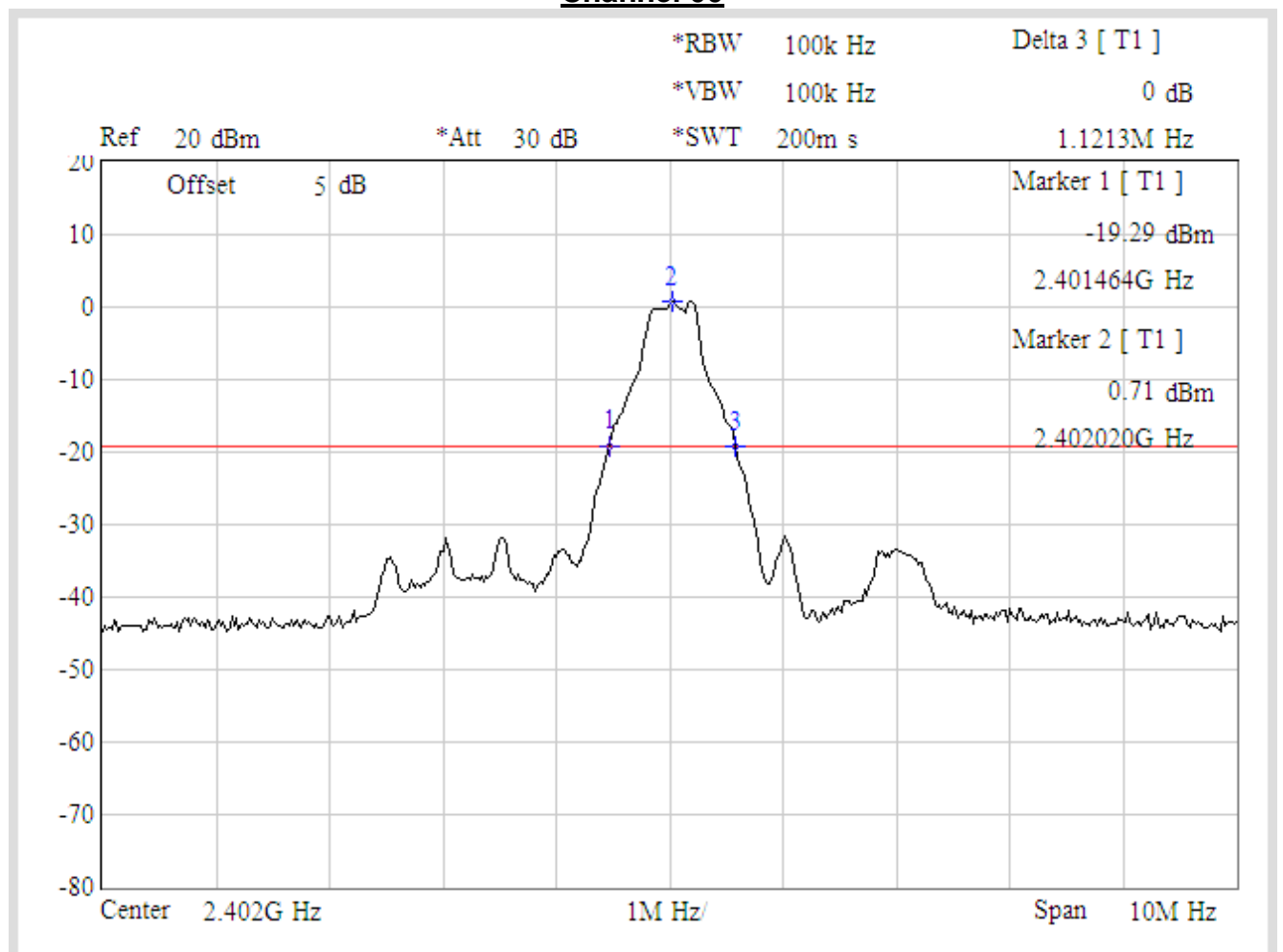

Product	Portable Navigation Device		
Test Item	Occupied Bandwidth		
Test Mode	Transmit		
Date of Test	2008/03/28	Test Site	No.1 OATS

1M-GFSK Modulation, PRBS Packet Type (99%)

Channel No.	Frequency (MHz)	Measure Level (MHz)	Limit (MHz)	Result
00	2402.00	0.98	--	Pass

Channel 00

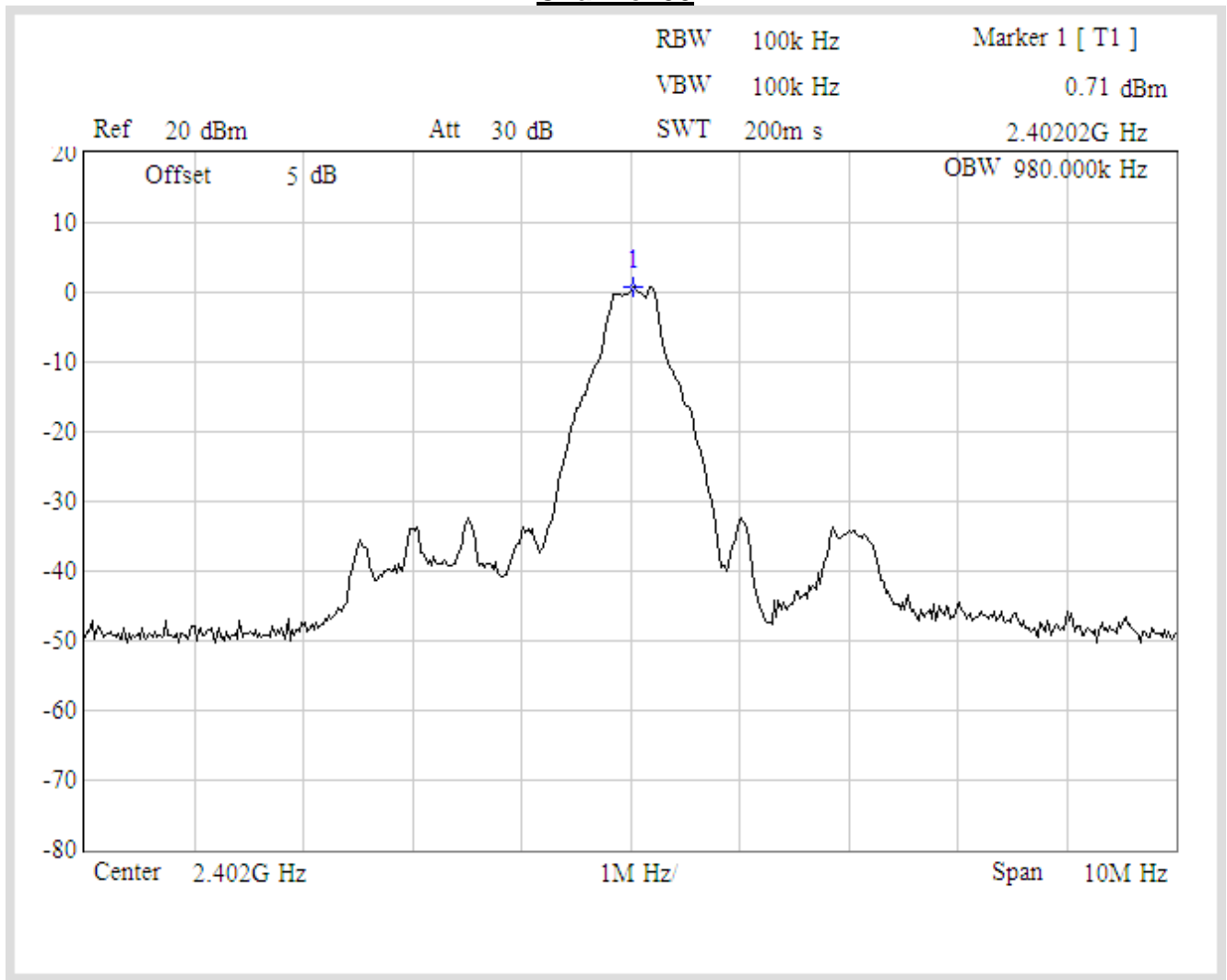

Product	Portable Navigation Device		
Test Item	Occupied Bandwidth		
Test Mode	Transmit		
Date of Test	2008/03/28	Test Site	No.1 OATS

1M-GFSK Modulation, PRBS Packet Type

Channel No.	Frequency (MHz)	Measure Level (MHz)	Limit (MHz)	Result
39	2441.00	1.121	--	Pass

Channel 39

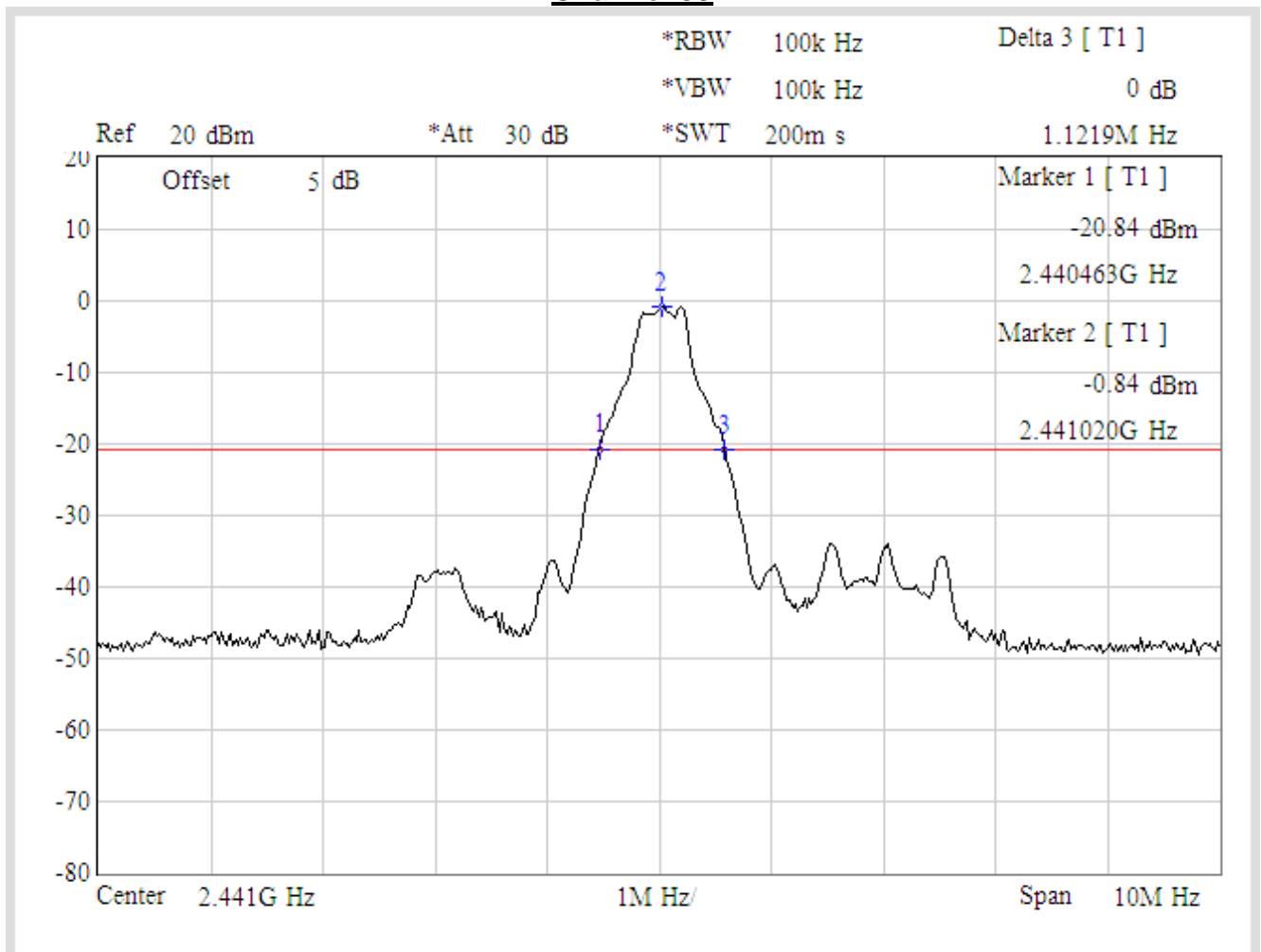

Product	Portable Navigation Device		
Test Item	Occupied Bandwidth		
Test Mode	Transmit		
Date of Test	2008/03/28	Test Site	No.1 OATS

1M-GFSK Modulation, PRBS Packet Type (99%)

Channel No.	Frequency (MHz)	Measure Level (MHz)	Limit (MHz)	Result
39	2441.00	1.03	--	Pass

Channel 39

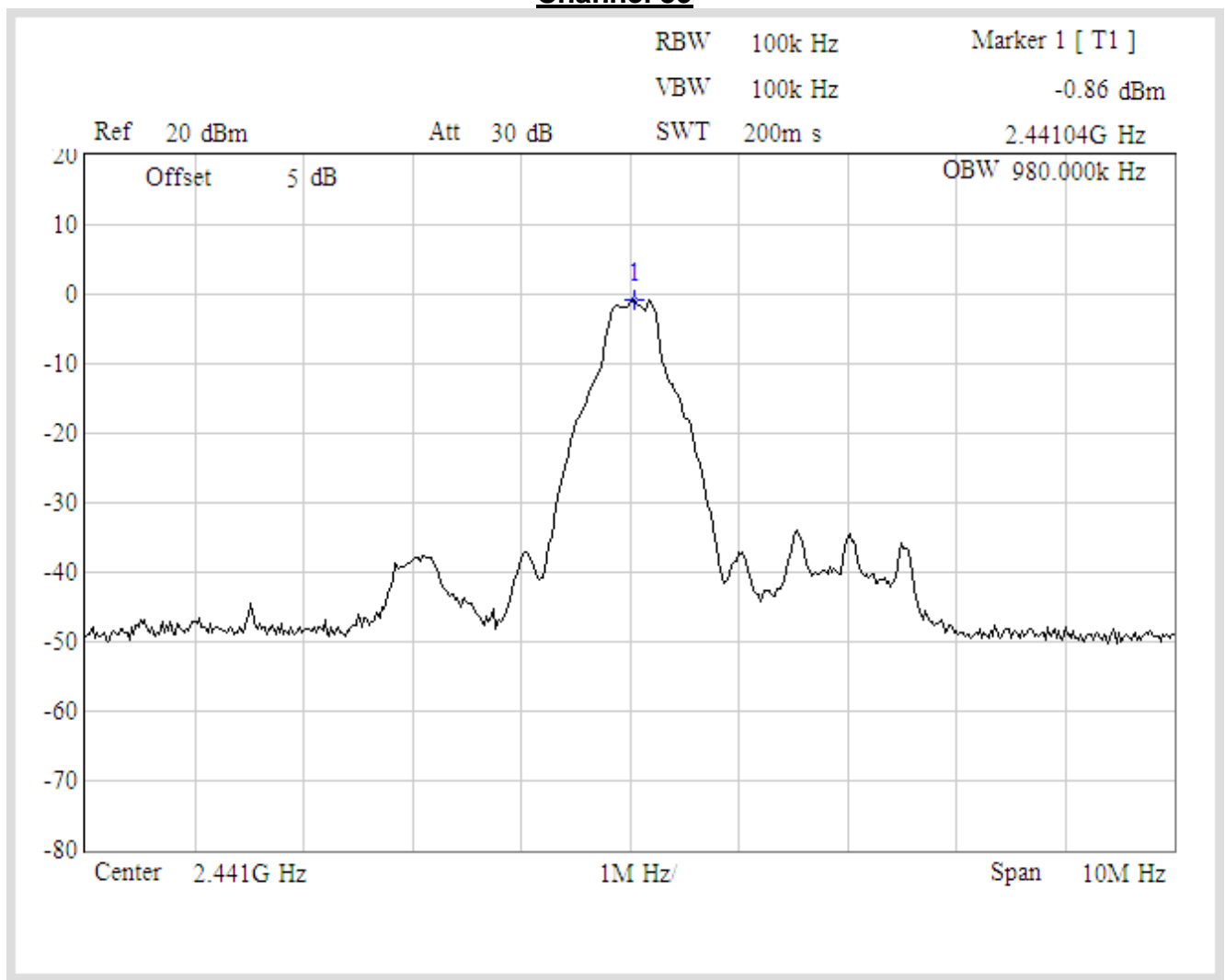

Product	Portable Navigation Device		
Test Item	Occupied Bandwidth		
Test Mode	Transmit		
Date of Test	2008/03/28	Test Site	No.1 OATS

1M-GFSK Modulation, PRBS Packet Type

Channel No.	Frequency (MHz)	Measure Level (MHz)	Limit (MHz)	Result
78	2480.00	1.117	--	Pass

Channel 78

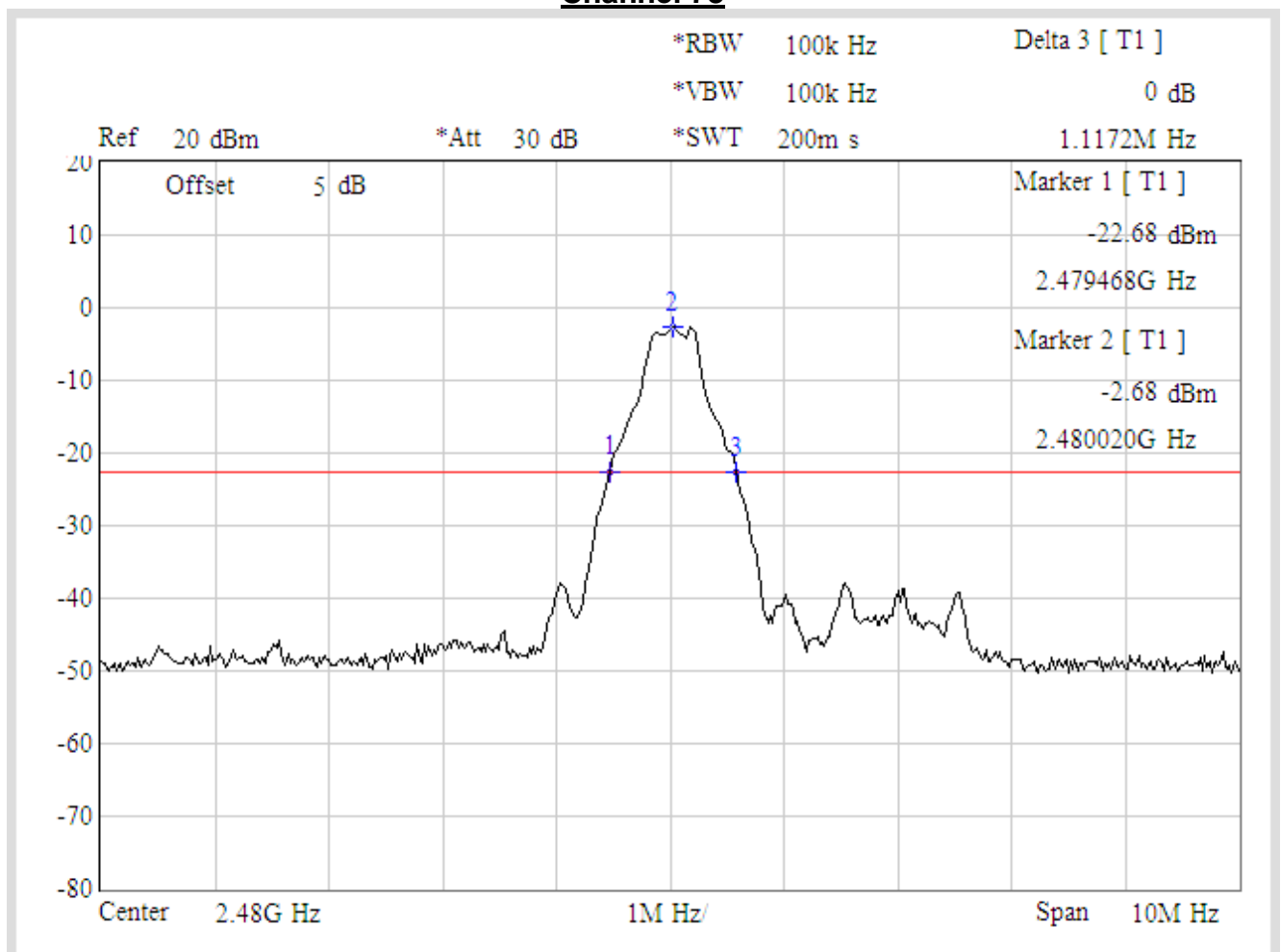

Product	Portable Navigation Device		
Test Item	Occupied Bandwidth		
Test Mode	Transmit		
Date of Test	2008/03/28	Test Site	No.1 OATS

1M-GFSK Modulation, PRBS Packet Type (99%)

Channel No.	Frequency (MHz)	Measure Level (MHz)	Limit (MHz)	Result
78	2480.00	0.98	--	Pass

Channel 78

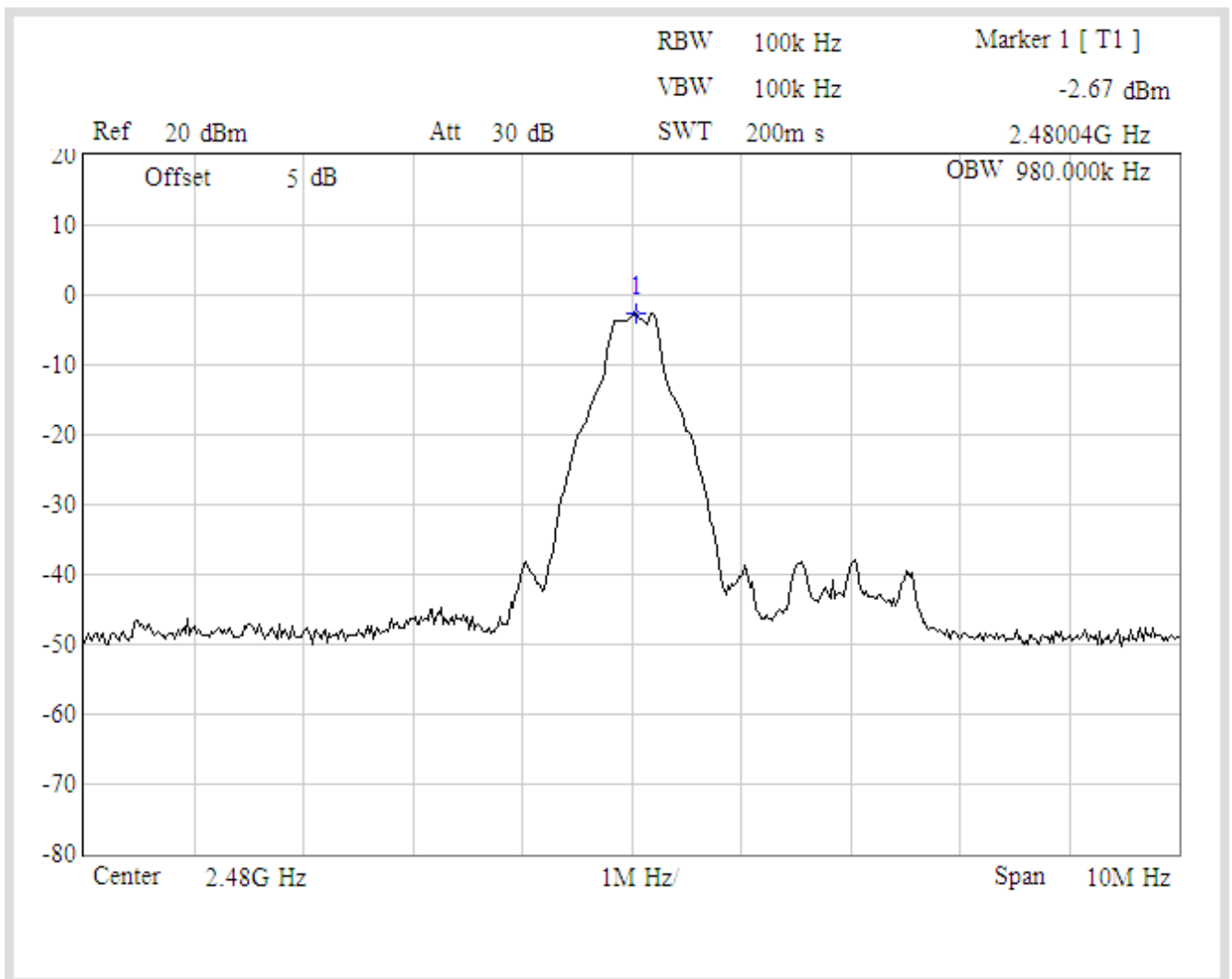

10. Dwell Time

10.1. Test Equipment

The following test equipment are used during the test:

Item	Equipment	Manufacturer	Model No. / Serial No.	Last Cal.
1	Spectrum Analyzer	R & S	FSP / 100561	Mar., 2008
2	No.1 OATS			Sep., 2007

Note: 1. All equipments that need to calibrate are with calibration period of 1 year.

10.2. Test Setup

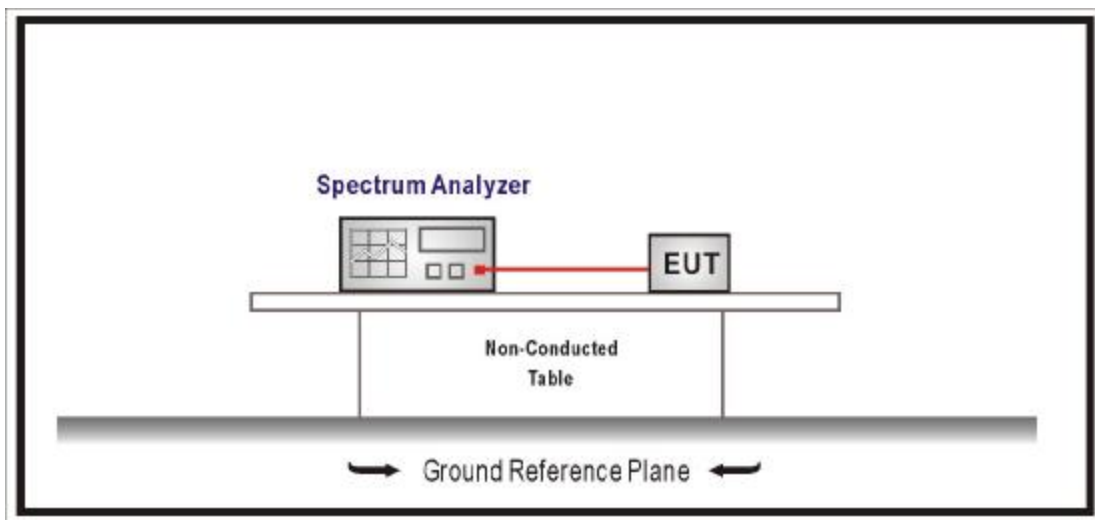

10.3. Limits

For frequency hopping systems operating in the 902-928 MHz band: if the 20 dB bandwidth of the hopping channel is less than 250 kHz, the system shall use at least 50 hopping frequencies and the average time of occupancy on any frequency shall not be greater than 0.4 seconds within a 20 second period; if the 20 dB bandwidth of the hopping channel is 250 kHz or greater, the system shall use at least 25 hopping frequencies and the average time of occupancy on any frequency shall not be greater than 0.4 seconds within a 10 second period. For frequency hopping systems operating in the 2400-2483.5 MHz bands. The average time of occupancy on any channel shall not be greater than 0.4 seconds within a period of 0.4 seconds multiplied by the number of hopping channels employed. For frequency hopping systems operating in the 5725-5850 MHz bands. The average time of occupancy on any frequency shall not be greater than 0.4 seconds within a 30 second period.

10.4. Test Procedures

The EUT was setup according to ANSI C63.4, 2003 and tested according to FHSS test procedure of FCC Public Notice DA 00-705 for compliance to FCC 47CFR 15.247 requirements

Span = zero span, centered on a hopping channel

RBW = 1 MHz, VBW \geq RBW

Sweep = as necessary to capture the entire dwell time per hopping channel

Detector function = peak, Trace = max hold

10.5. Test Specification

According to FCC Part 15 Subpart C Paragraph 15.247: 2006

10.6. Test Result

Product	Portable Navigation Device		
Test Item	Dwell Time		
Test Mode	Transmit		
Date of Test	2008/03/28	Test Site	No.1 OATS

Occupancy Time of Frequency Hopping System-DH 5

A) 2402MHz Test Time Period: $0.4 \times 79 = 31.6\text{sec}$, Hopping Times Within 1sec: $5/20\text{msec} = 250 / \text{sec}$

The Maximum Occupancy Time Within 31.6sec: $0.000308 \times (250/79) \times 31.6 = 0.308\text{sec}$.

B) 2441MHz Test Time Period: $0.4 \times 79 = 31.6\text{sec}$, Hopping Times Within 1sec: $5/20\text{msec} = 250 / \text{sec}$

The Maximum Occupancy Time Within 31.6sec: $0.000308 \times (250/79) \times 31.6 = 0.308\text{sec}$.

C) 2480MHz Test Time Period: $0.4 \times 79 = 31.6\text{sec}$, Hopping Times Within 1sec: $5/20\text{msec} = 250 / \text{sec}$

The Maximum Occupancy Time Within 31.6sec: $0.000312 \times (250/79) \times 31.6 = 0.312\text{sec}$.

Test Result: The Average Occupancy Time of Each Highest , Middle and Lowest Channel Is Less Than 0.4sec , And Corresponds to The Standard .

Hop rate-2402MHz

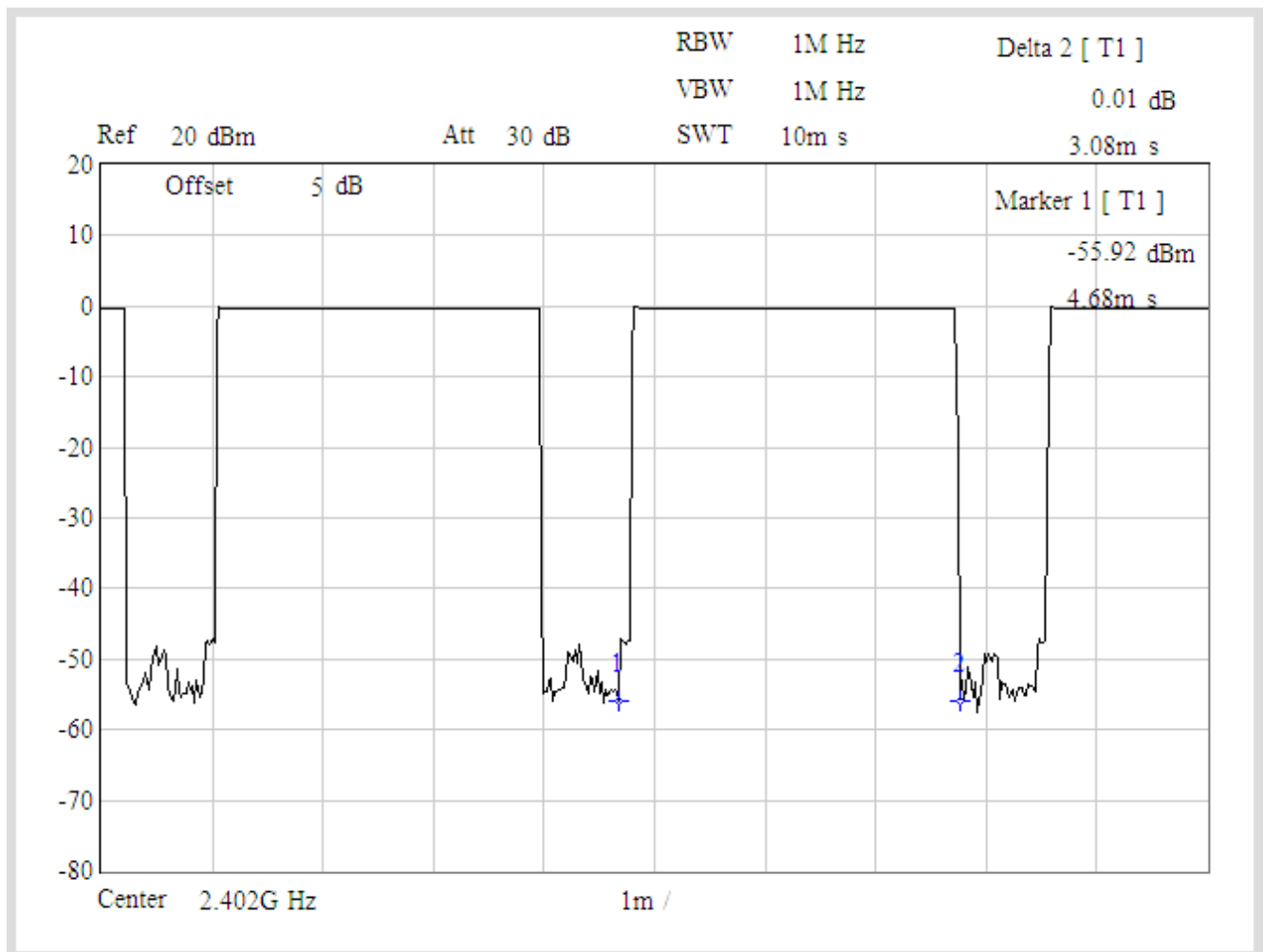

Hop rate-2441MHz

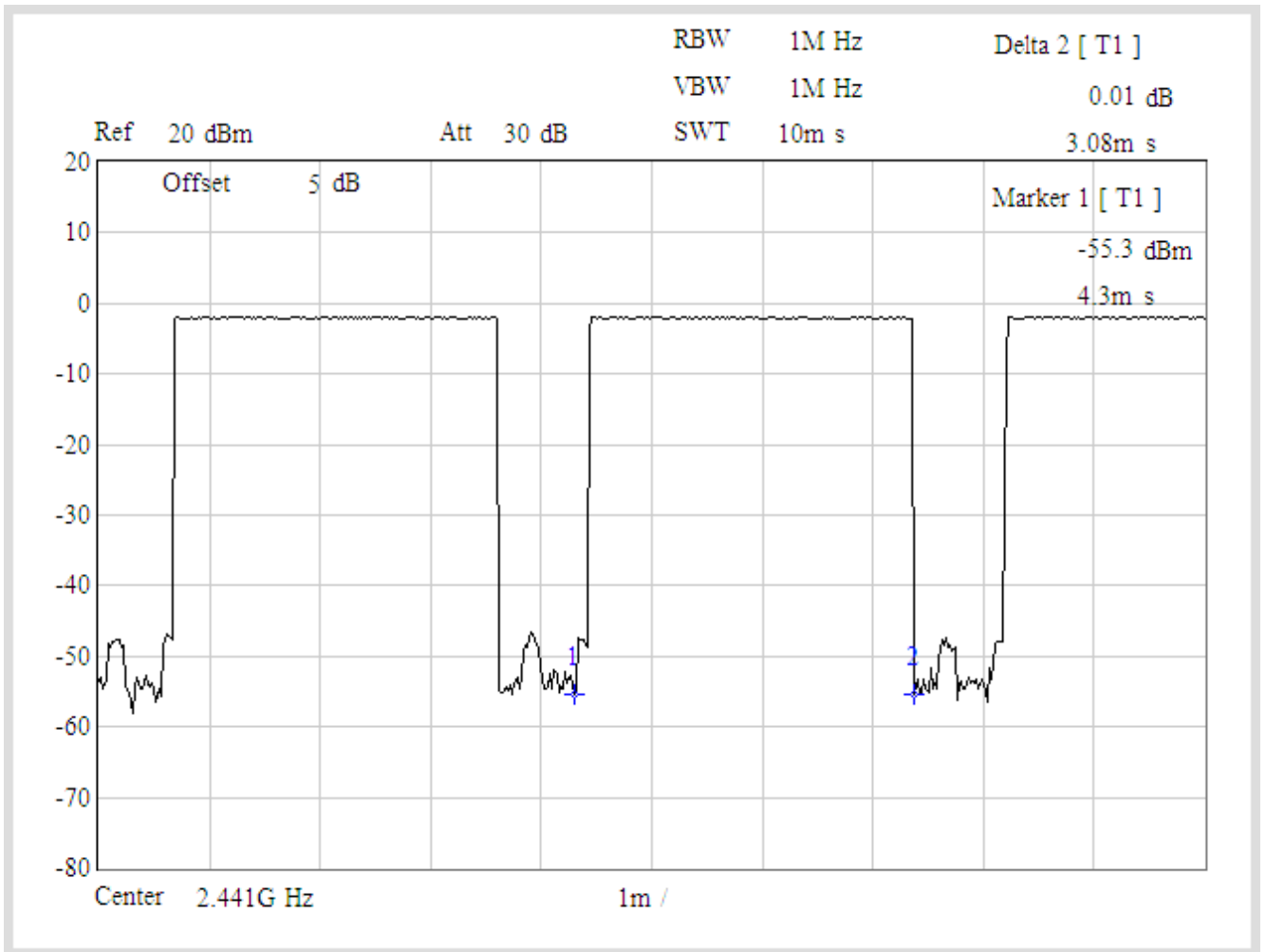

Hop rate-2480MHz

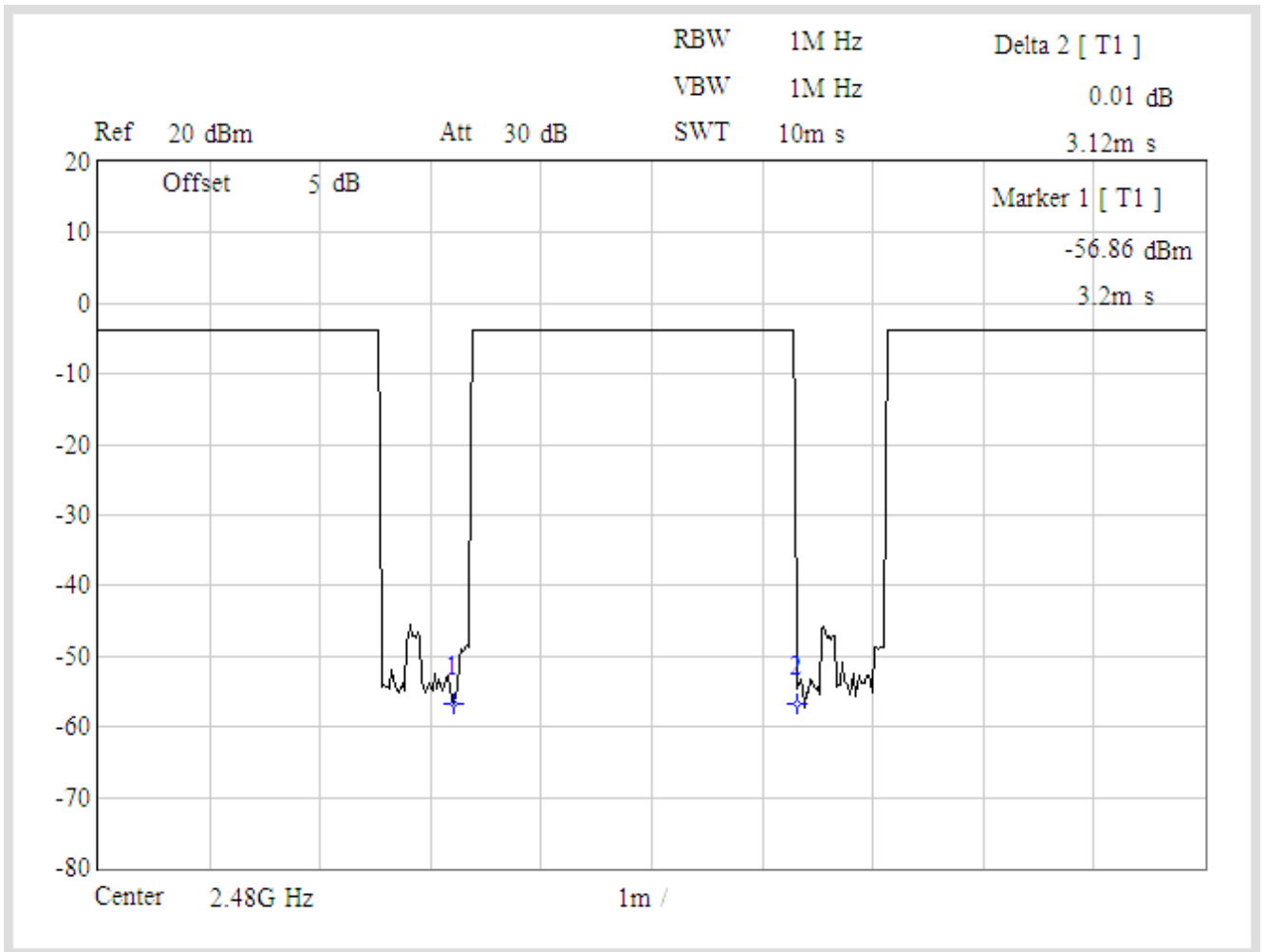

Note: Dwell time = time slot length * hop rate / number of hopping channels * period

Time slot length

