

FCC Test Report

EQUIPMENT : Tracker007
BRAND NAME : HOLUX
MODEL NO. : GR515
FCC ID : RJI-TRACKER007
STANDARD : 47 CFR Part 2, 22(H), 24(E)
CLASSIFICATION : PCS Licensed Transmitter worn on body (PCT)
Tx FREQUENCY RANGE : GSM850 : 824.2 ~ 848.8MHz
GSM1900 : 1850.2 ~ 1909.8 MHz
Rx FREQUENCY RANGE : GSM850 : 869.2 ~ 893.8MHz
GSM1900 : 1930.2 ~ 1989.8 MHz
MAX. RF OUTPUT POWER : GSM850 : 0.38 W
GSM1900 : 1.43 W
EMISSION DESIGNATOR : 300KGXW
APPLICANT : **HOLUX Technology, Inc**
No. 1-1, Innovation Road I, Science-Based Industrial Park,
Hsinchu 300, Taiwan, R.O.C

The product sample received on Aug. 08, 2008 and completely tested on Aug. 29, 2008. We, SPORTON INTERNATIONAL Inc., would like to declare that the tested sample has been evaluated in accordance with the procedures given in ANSI C63.4-2003 and shown compliance with the applicable technical standards.

The test results in this report apply exclusively to the tested model / sample. Without written approval of SPORTON INTERNATIONAL INC., the test report shall not be reproduced except in full.



Reviewed by: Roy Wu
/ Manager



SPORTON International Inc.

No. 52, Hwa Ya 1st Rd., Hwa Ya Technology Park, Kwei-Shan Hsiang, Tao Yuan Hsien, Taiwan, R.O.C.



TABLE OF CONTENTS

SUMMARY OF TEST RESULT 3

1 GENERAL DESCRIPTION 5

1.1 Applicant..... 5

1.2 Manufacturer 5

1.3 Feature of Equipment Under Test..... 5

1.4 Testing Site..... 6

1.5 Applied Standards 6

1.6 Ancillary Equipment List..... 6

2 TEST CONFIGURATION OF EQUIPMENT UNDER TEST 7

2.1 Test Mode..... 7

2.2 Connection Diagram of Test System 7

3 TEST RESULT 8

3.1 Conducted Output Power Measurement..... 8

3.2 Effective Radiated Power and Effective Isotropic Radiated Power Measurement 10

3.3 Occupied Bandwidth and Band Edge Measurement 12

3.4 Conducted Emission Measurement 21

3.5 Field Strength of Spurious Radiation Measurement 27

3.6 Frequency Stability Measurement..... 32

4 LIST OF MEASURING EQUIPMENTS..... 35

5 UNCERTAINTY OF EVALUATION 36

6 CERTIFICATION OF TAF ACCREDITATION..... 37

APPENDIX A. PHOTOGRAPHS OF EUT

APPENDIX B. SETUP PHOTOGRAPHS



SUMMARY OF TEST RESULT

Report Section	FCC Rule	IC Rule	Description	Limit	Result
3.1	§2.1046	NA	Conducted Output Power	NA	Pass
3.2	§22.913(a)(2)	RSS-132(4.4) SRSP-503(5.1.3)	Effective Radiated Power	< 7 Watts for FCC (<6.3 Watts for IC)	Pass
3.2	§24.232(c)	RSS-133 (6.4) SRSP-510(5.1.2)	Equivalent Isotropic Radiated Power	< 2 Watts	Pass
3.3	§2.1049 §22.917(a) §24.238(a)	NA	Occupied Bandwidth	NA	Pass
3.3	§2.1051 §22.917(a) §24.238(a)	RSS-132 (4.5.1) RSS-133 (6.5.1)	Band Edge Measurement	< 43+10log10(P[Watts])	Pass
3.4	§2.1051 §22.917(a) §24.238(a)	RSS-132 (4.5.1) RSS-133 (6.5.1)	Conducted Emission	< 43+10log10(P[Watts])	Pass
3.5	§2.1053 §22.917(a) §24.238(a)	RSS-132 (4.5.1) RSS-133 (6.5.1)	Field Strength of Spurious Radiation	< 43+10log10(P[Watts])	Pass
3.6	§2.1055 §22.355 §24.235	RSS-132(4.3) RSS-133(6.3)	Frequency Stability for Temperature & Voltage	< 2.5 ppm	Pass



REVISION HISTORY

REPORT NO.	VERSION	DESCRIPTION	ISSUED DATE
FG880820	Rev. 01	Initial issue of report	Sep. 08, 2008

1 General Description

1.1 Applicant

HOLUX Technology, Inc

No. 1-1, Innovation Road I, Science-Based Industrial Park, Hsinchu 300, Taiwan, R.O.C

1.2 Manufacturer

HOLUX Technology, Inc

No. 1-1, Innovation Road I, Science-Based Industrial Park, Hsinchu 300, Taiwan, R.O.C

1.3 Feature of Equipment Under Test

Product Feature & Specification	
Equipment	Tracker007
Brand Name	HOLUX
Model No.	GR515
Tx Frequency Range	GSM850 : 824 MHz ~ 849 MHz GSM1900 : 1850 MHz ~ 1910 MHz
Rx Frequency Range	GSM850 : 869 MHz ~ 894 MHz GSM1900 : 1930 MHz ~ 1990 MHz
Maximum Output Power to Antenna	GSM850 : 31.92dBm GSM1900 : 29.09dBm
Max. ERP/EIRP Power	GSM850 : 0.38 W (25.77 dBm) GSM1900 : 1.43 W (31.55 dBm)
Type of Modulation :	GMSK
DUT Stage :	Identical Prototype

2nd Component Source List

Component model	
Adapter	DMATEK / SYS1196-0605-W2
Car Charger	ChenTai / CC-0103
Battery	Edan / LP523442D
USB Cable	DMATEK / UL 2725 28# IP+28# 2C

Remark:

- The above EUT's information was declared by manufacturer. Please refer to the specifications or user's manual for more detailed description.
- For accessories equipped with this EUT, please refer to the appendix of the external photo.
- For other wireless features of this EUT, the test report will be issued separately.

1.4 Testing Site

Test Site	SPORTON INTERNATIONAL INC.		
Test Site Location	No. 52, Hwa Ya 1 st Rd., Hwa Ya Technology Park, Kwei-Shan Hsiang, Tao Yuan Hsien, Taiwan, R.O.C TEL: +886-3-3273456 / FAX: +886-3-3284978		
Test Site No.	Sporton Site No.		FCC/IC Registration No.
	TH02-HY	03CH07-HY	TW1022/4086B-1

1.5 Applied Standards

According to the specifications of the manufacturer, the EUT must comply with the requirements of the following standards:

- ♦ Preliminary Guidance for Receiving Applications for Certification of 3G Device. May 9, 2006.
- ♦ 47 CFR Part 2, 22(H), 24(E)
- ♦ ANSI C63.4-2003
- ♦ ANSI / TIA / EIA-603-C-2004
- ♦ IC RSS-132, RSS-133

Remark:

- ♦ All test items were verified and recorded according to the standards and without any deviation during the test.
- ♦ This EUT has also been tested and complied with the requirements of FCC Part 15, Subpart B (DoC), recorded in a separate test report.

1.6 Ancillary Equipment List

Item	Equipment	Trade Name	Model Name	FCC ID	Data Cable / Power Cord
1	Base Station	Agilent	E5515C	N/A	Unshielded, 1.8m

2 Test Configuration of Equipment Under Test

2.1 Test Mode

During all testing, EUT is in link mode with base station emulator at maximum power level. The spurious emission measurements were carried out in semi-anechoic chamber with 3-meter test range, and EUT is rotated on three test planes to find out the worst emission.

Frequency range investigated for radiated emission:

30 MHz to 9000 MHz for GSM850; 30MHz to 19000 MHz for GSM1900.

Test Modes		
Band	Radiated TCs	Conducted TCs
GSM 850	■ GSM Link	■ GSM Link
GSM 1900	■ GSM Link	■ GSM Link

2.2 Connection Diagram of Test System

<GSM Link Mode>

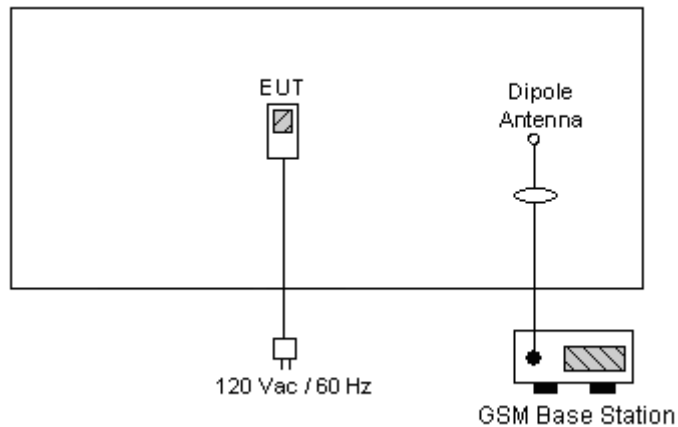

3 Test Result

3.1 Conducted Output Power Measurement

3.1.1 Description of the Conducted Output Power Measurement

A base station simulator was used to establish communication with the EUT. Its parameters were set to transmit the maximum power on the EUT. The measured power in the radio frequency on the transmitter output terminals shall be reported.

3.1.2 Measuring Instruments

See list of measuring instruments of this test report.

3.1.3 Test Procedures

1. The transmitter output port was connected to base station.
2. Set EUT at maximum power through base station.
3. Select lowest, middle, and highest channels for each band and different modulation.

3.1.4 Test Setup

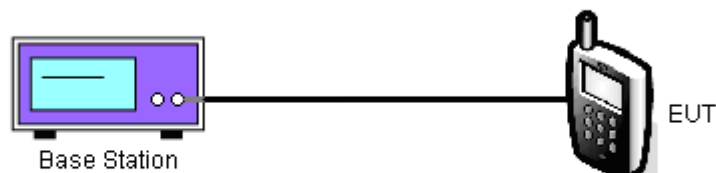



3.1.5 Test Result of Conducted Output Power

Cellular				
Modes	Channel	Frequency (MHz)	Conducted Power	
			(dBm)	(Watts)
GSM	128	824.2 (Low)	31.90	1.55
	189	836.4 (Mid)	31.91	1.55
	251	848.8 (High)	31.92	1.56

PCS				
Modes	Channel	Frequency (MHz)	Conducted Power	
			(dBm)	(Watts)
GSM	512	1850.2 (Low)	29.09	0.81
	661	1880.0 (Mid)	29.02	0.80
	810	1909.8 (High)	28.77	0.75

3.2 Effective Radiated Power and Effective Isotropic Radiated Power Measurement

3.2.1 Description of the ERP/EIRP Measurement

ERP/EIRP is measured by substitution method according to ANSI / TIA / EIA-603-C-2004. The ERP of mobile transmitters must not exceed 7 Watts and the EIRP of mobile transmitters are limited to 2 Watts.

3.2.2 Measuring Instruments

See list of measuring instruments of this test report.

3.2.3 Test Procedures

1. The EUT was placed on a tutable with 1.0 meter height in a fully anechoic chamber.
2. The EUT was set at 1.2 meters from the receiving antenna, which was mounted on the antenna tower.
3. The table was rotated 360 degrees to determine the position of the highest radiated power.
4. The height of the receiving antenna is adjusted to look for the maximum ERP/EIRP.
5. Taking the record of maximum ERP/EIRP.
6. A dipole antenna was substituted in place of the EUT and was driven by a signal generator.
7. The conducted power at the terminal of the dipole antenna is measured.
8. Repeat step 3 to step 5 to get the maximum ERP/EIRP of the substitution antenna.
9. $ERP/EIRP = P_s + E_t - E_s + G_s = P_s + R_t - R_s + G_s$

P_s (dBm) : Input power to substitution antenna.

G_s (dBi or dBd) : Substitution antenna Gain.

$E_t = R_t + AF$

$E_s = R_s + AF$

AF (dB/m) : Receive antenna factor

R_t : The highest received signal in spectrum analyzer for EUT.

R_s : The highest received signal in spectrum analyzer for substitution antenna.

3.2.4 Test Setup

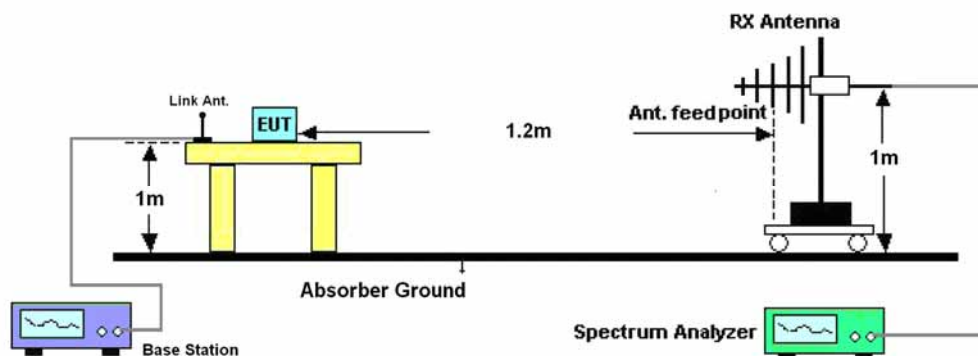



3.2.5 Test Result of ERP

GSM850						
Horizontal Polarization						
Frequency (MHz)	Rt (dBm)	Rs (dBm)	Ps (dBm)	Gs (dBd)	ERP (dBm)	ERP (W)
824.20	-28.56	-48.12	0.00	-1.08	18.48	0.07
836.40	-28.16	-48.28	0.00	-0.93	19.19	0.08
848.80	-30.09	-48.35	0.00	-0.76	17.50	0.06
Vertical Polarization						
Frequency (MHz)	Rt (dBm)	Rs (dBm)	Ps (dBm)	Gs (dBd)	ERP (dBm)	ERP (W)
824.20	-21.13	-47.97	0.00	-1.08	25.76	0.38
836.40	-22.12	-48.01	0.00	-0.93	24.96	0.31
848.80	-21.52	-48.05	0.00	-0.76	25.77	0.38

3.2.6 Test Result of EIRP

GSM1900						
Horizontal Polarization						
Frequency (MHz)	Rt (dBm)	Rs (dBm)	Ps (dBm)	Gs (dBi)	EIRP (dBm)	EIRP (W)
1850.20	-32.33	-51.88	0.00	1.96	21.51	0.14
1880.00	-34.35	-52.99	0.00	2.00	20.64	0.12
1909.80	-37.69	-54.28	0.00	1.98	18.57	0.07
Vertical Polarization						
Frequency (MHz)	Rt (dBm)	Rs (dBm)	Ps (dBm)	Gs (dBi)	EIRP (dBm)	EIRP (W)
1850.20	-23.34	-52.13	0.00	1.96	30.75	1.19
1880.00	-23.62	-53.17	0.00	2.00	31.55	1.43
1909.80	-24.90	-54.13	0.00	1.98	31.21	1.32

3.3 Occupied Bandwidth and Band Edge Measurement

3.3.1 Description of Occupied Bandwidth and Band Edge Measurement

The power of any emission outside of the authorized operating frequency ranges must be lower than the transmitter power (P) by a factor of at least $43 + 10 \log (P)$ dB.

The emission bandwidth is defined as the width of the signal between two points, located at the 2 sides of the carrier frequency, outside of which all emissions are attenuated at least 26 dB below the transmitter power.

3.3.2 Measuring Instruments

See list of measuring instruments of this test report.

3.3.3 Test Procedures

1. The EUT was connected to Spectrum Analyzer and Base Station via power divider.
2. The 99% and 26 dB occupied bandwidth (BW) of the low, middle and high channels for the highest RF powers were measured.
3. The band edge of low and high channels for the highest RF powers were measured. Setting RBW as roughly BW/100.

3.3.4 Test Setup

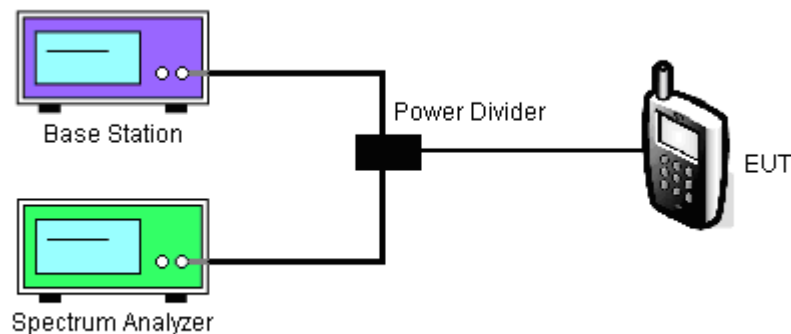



3.3.5 Test Result (Plots) of Occupied Bandwidth

Band :	GSM 850	Power Stage :	High
Test Mode :	GSM Link		

99% Occupied Bandwidth Plot on Channel 128

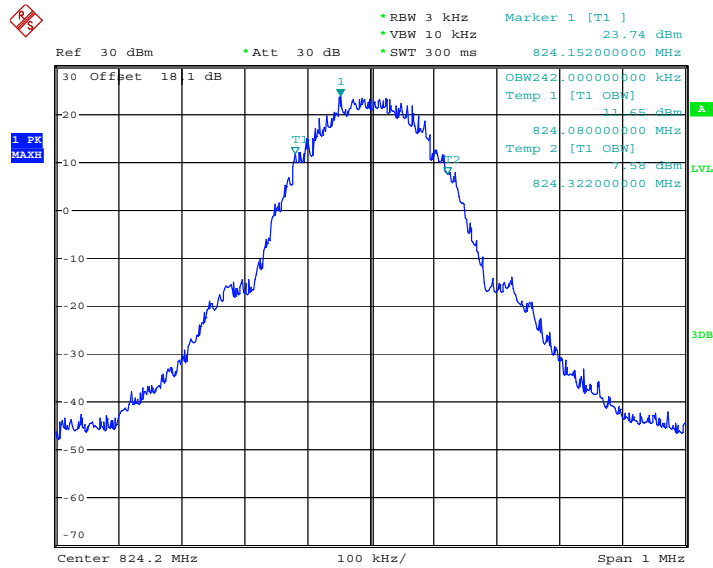

Date: 29.AUG.2008 17:22:27

99% Occupied Bandwidth Plot on Channel 189

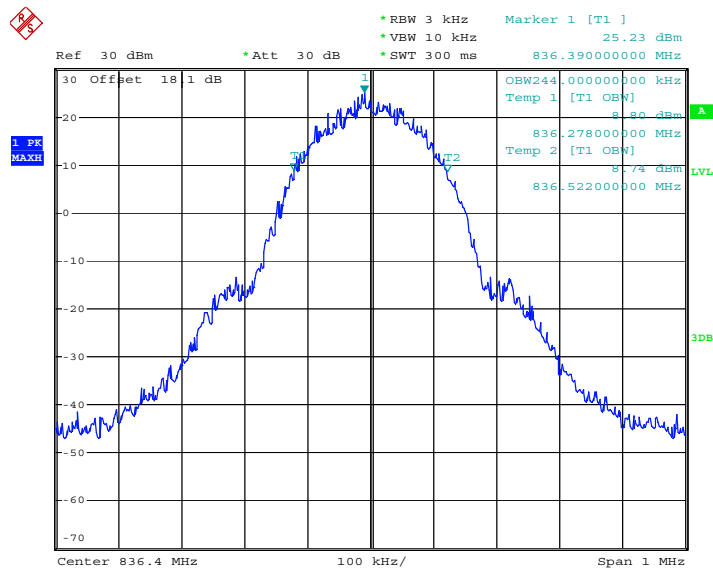

Date: 29.AUG.2008 17:23:50



99% Occupied Bandwidth Plot on Channel 251

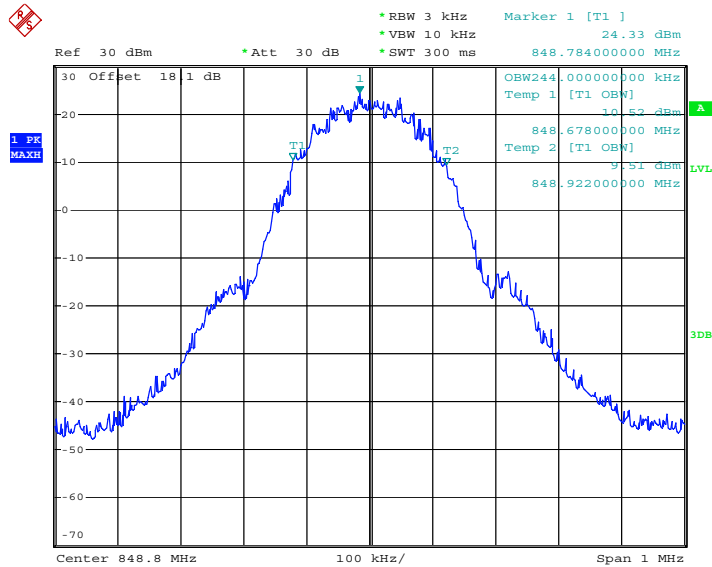

Date: 29.AUG.2008 17:20:57

26dB Bandwidth Plot on Channel 128

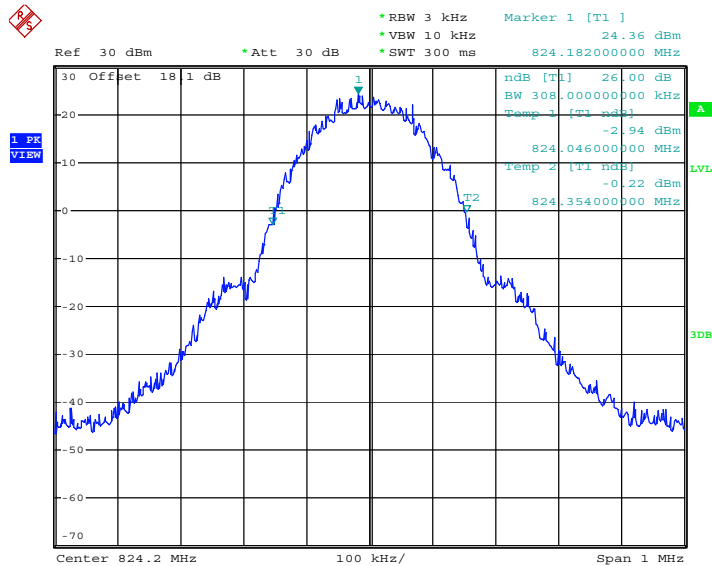

Date: 29.AUG.2008 17:17:14



26dB Bandwidth Plot on Channel 189

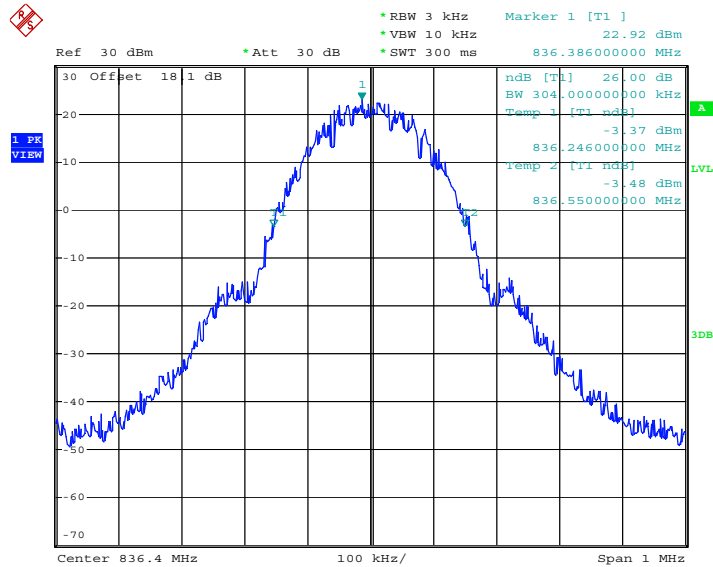

Date: 29.AUG.2008 17:17:53

26dB Bandwidth Plot on Channel 251

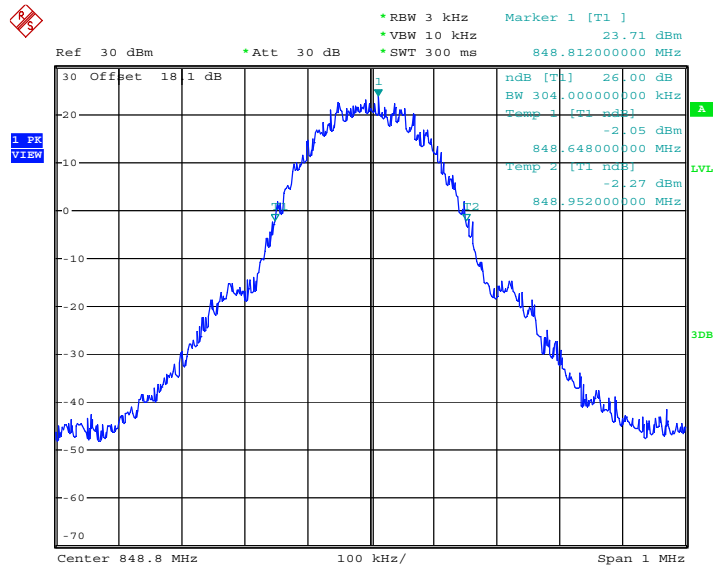

Date: 29.AUG.2008 17:18:37



Band :	GSM 1900	Power Stage :	High
Test Mode :	GSM Link		

99% Occupied Bandwidth Plot on Channel 512

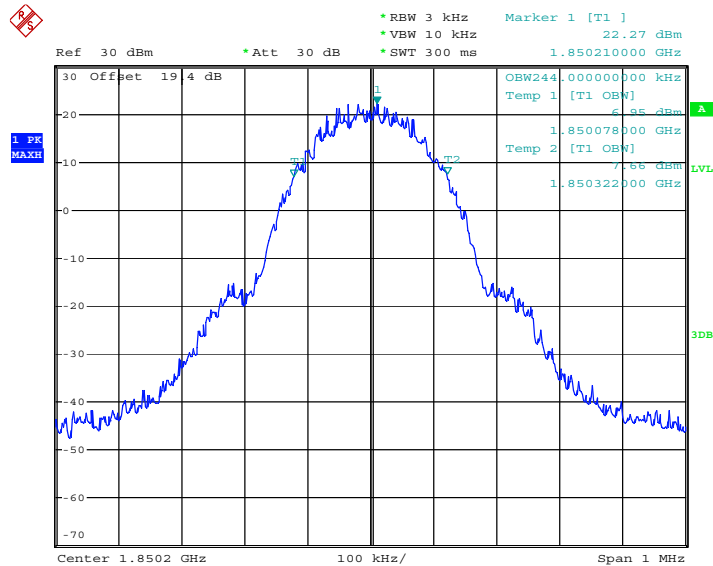

Date: 29.AUG.2008 17:46:33

99% Occupied Bandwidth Plot on Channel 661

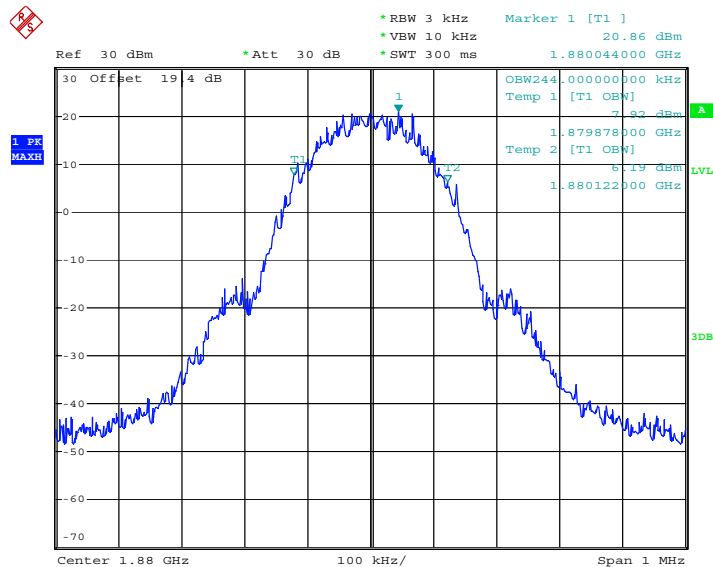

Date: 29.AUG.2008 17:47:22



99% Occupied Bandwidth Plot on Channel 810

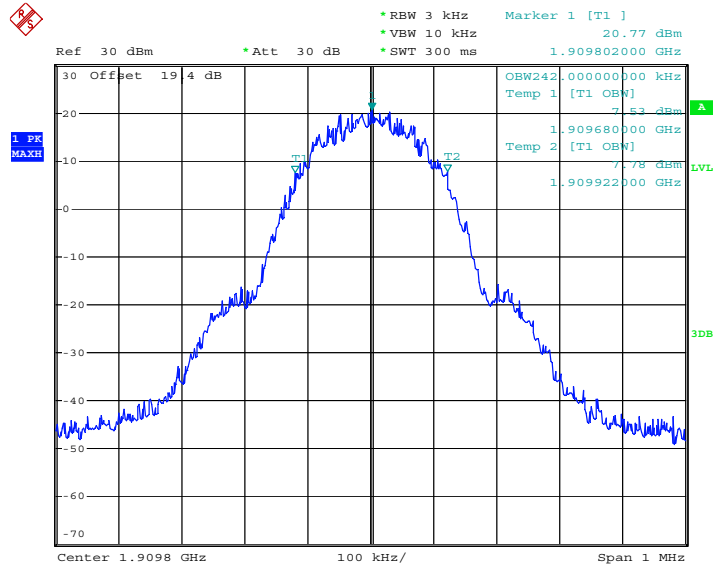

Date: 29.AUG.2008 17:45:20

26dB Bandwidth Plot on Channel 512

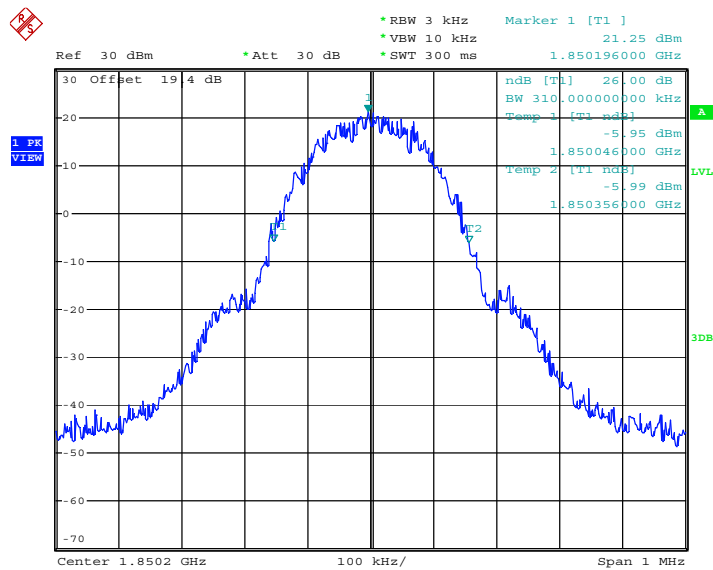

Date: 29.AUG.2008 17:42:52



26dB Bandwidth Plot on Channel 661

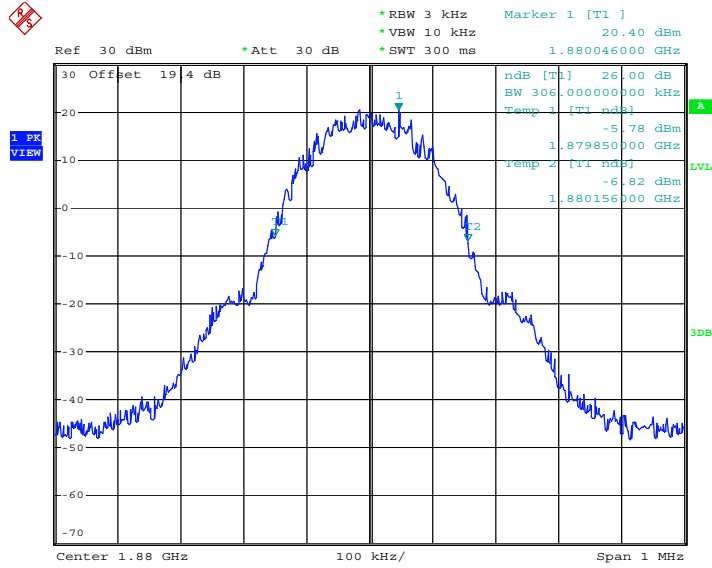

Date: 29.AUG.2008 17:43:31

26dB Bandwidth Plot on Channel 810

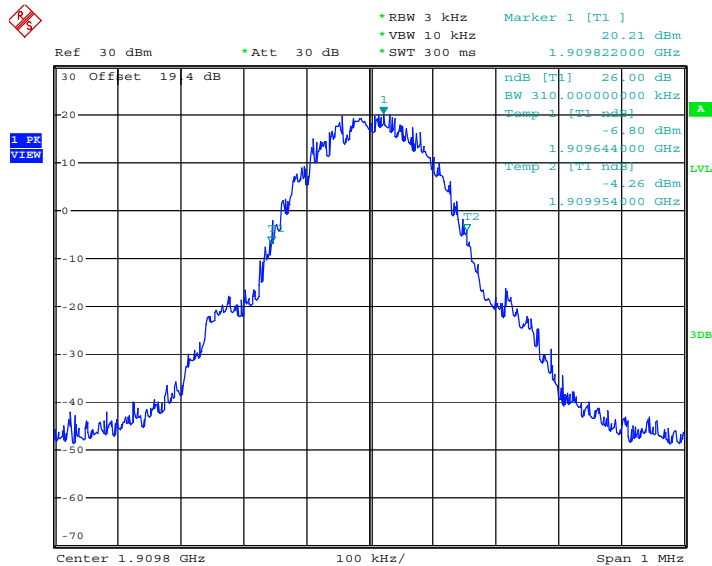

Date: 29.AUG.2008 17:44:45



3.3.6 Test Result (Plots) of Conducted Band Edges

Band :	GSM 850	Power Stage :	High
Test Mode :	GSM Link		

Low Band Edge Plot on Channel 128

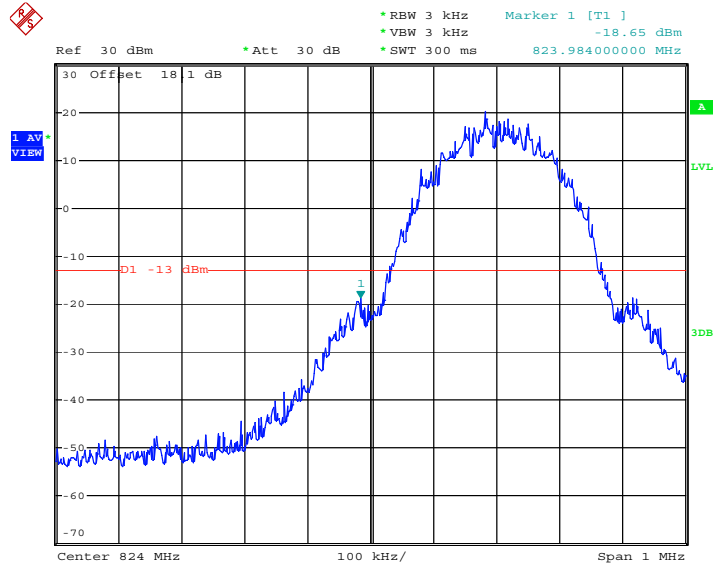

Date: 29.AUG.2008 17:29:57

High Band Edge Plot on Channel 251

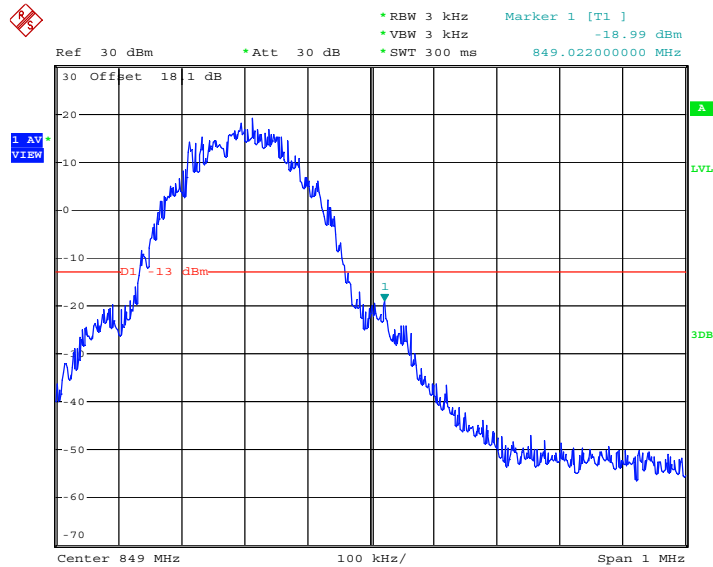

Date: 29.AUG.2008 17:26:25



Band :	GSM 1900	Power Stage :	High
Test Mode :	GSM Link		

Low Band Edge Plot on Channel 512

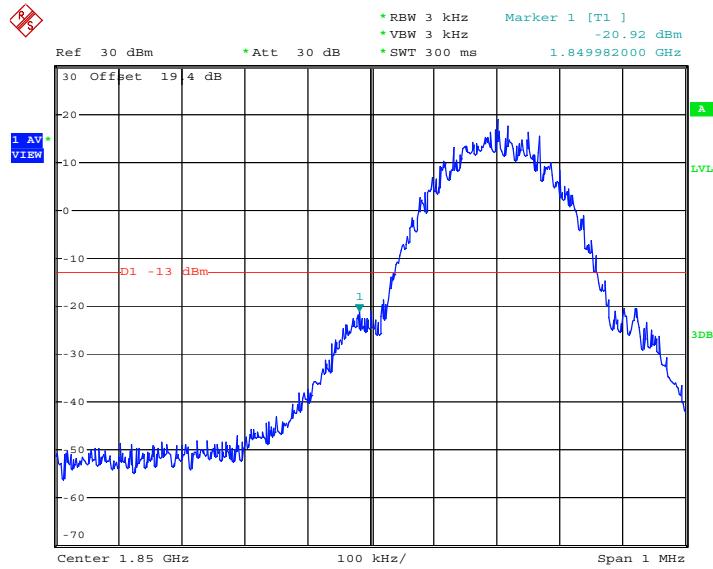

Date: 29.AUG.2008 17:49:31

High Band Edge Plot on Channel 810

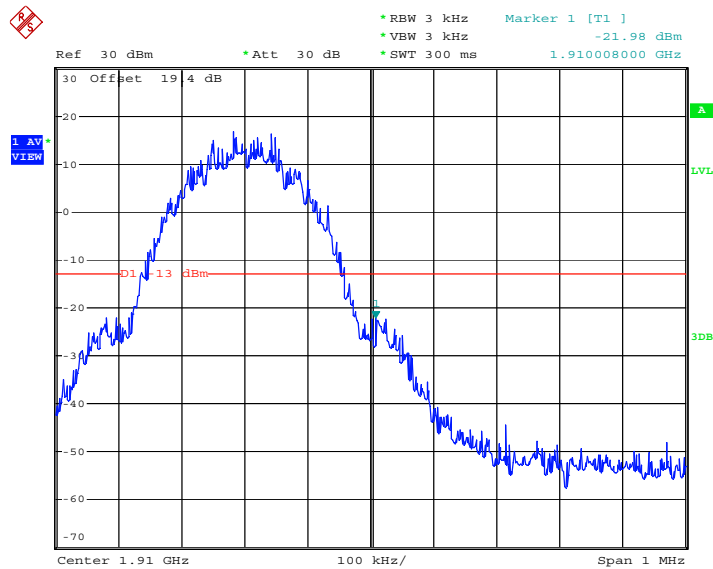

Date: 29.AUG.2008 17:53:22

3.4 Conducted Emission Measurement

3.4.1 Description of Conducted Emission Measurement

The power of any emission outside of the authorized operating frequency ranges must be lower than the transmitter power (P) by a factor of at least $43 + 10 \log (P)$ dB.

It is measured by means of a calibrated spectrum analyzer and scanned from 30 MHz up to a frequency including its 10th harmonic.

3.4.2 Measuring Instruments

See list of measuring instruments of this test report.

3.4.3 Test Procedures

1. The EUT was connected to spectrum analyzer and base station via power divider.
2. The middle channel for the highest RF power within the transmitting frequency was measured.
3. The conducted spurious emission for the whole frequency range was taken.

3.4.4 Test Setup

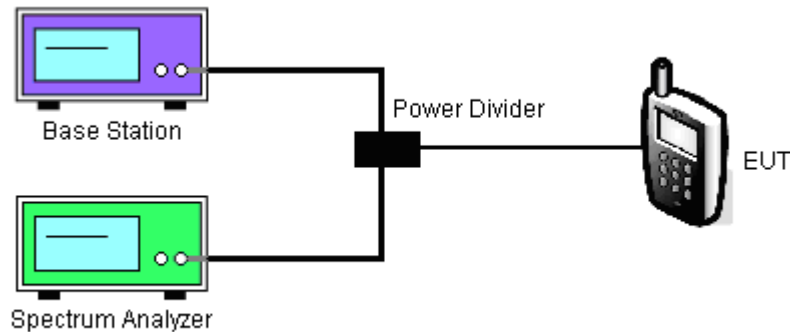



3.4.5 Test Result of Conducted Emission

Band :	GSM 850	Channel :	189
Test Mode :	GSM Link		

Conducted Emission Plot below 1GHz

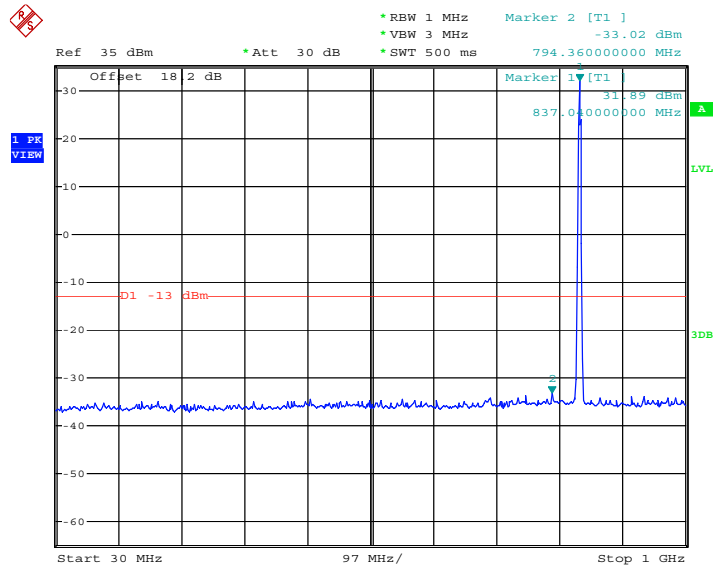

Date: 29.AUG.2008 17:56:21

Conducted Emission Plot between 1GHz ~ 3GHz

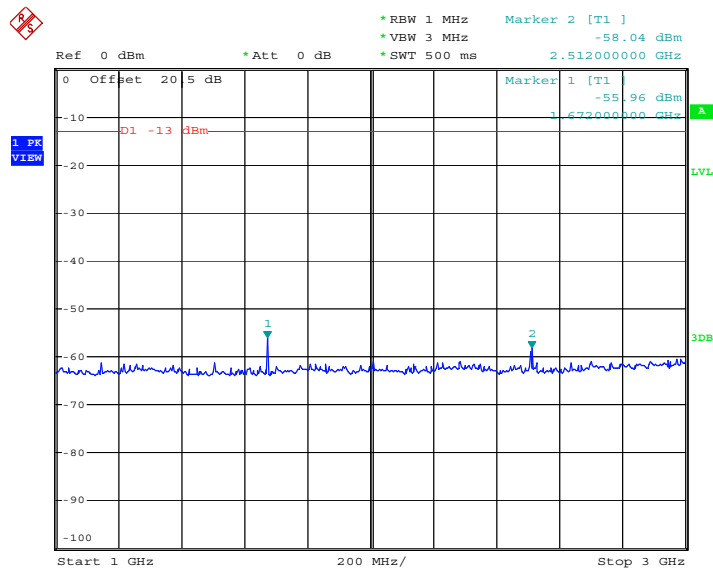

Date: 29.AUG.2008 18:16:55



Conducted Emission Plot between 3GHz ~ 7GHz

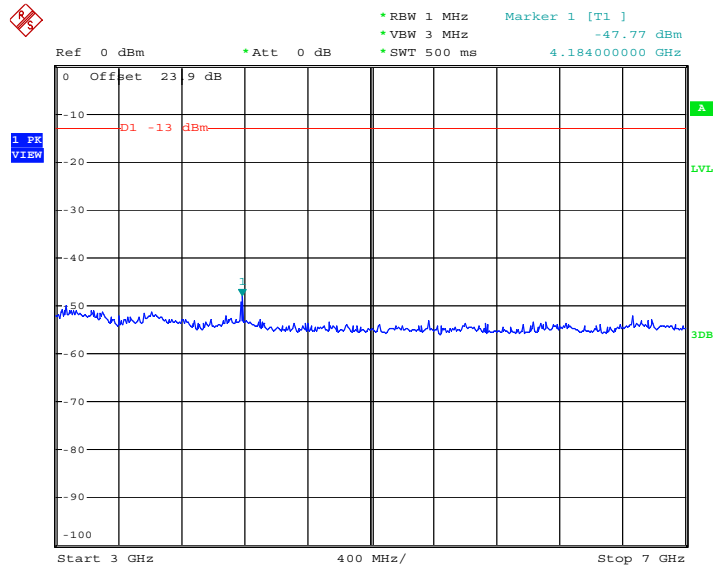

Date: 29.AUG.2008 18:18:33

Conducted Emission Plot between 7GHz ~ 9GHz

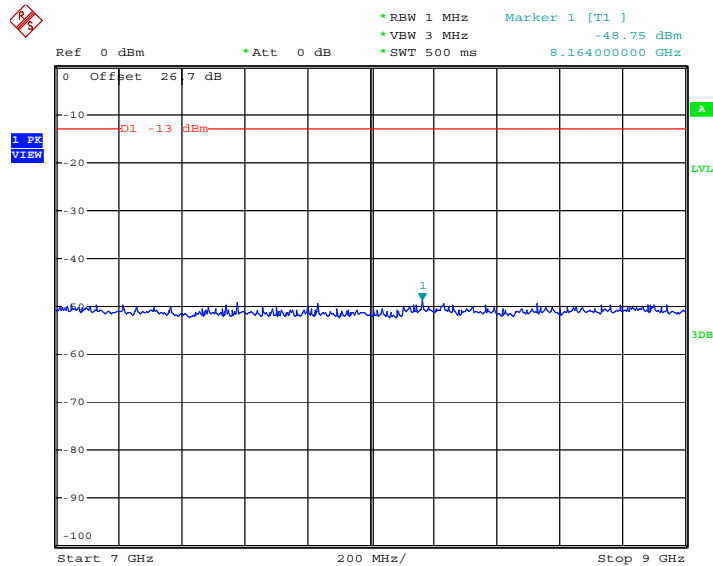

Date: 29.AUG.2008 18:27:02



Band :	GSM 1900	Channel :	661
Test Mode :	GSM Link		

Conducted Emission Plot below 1GHz

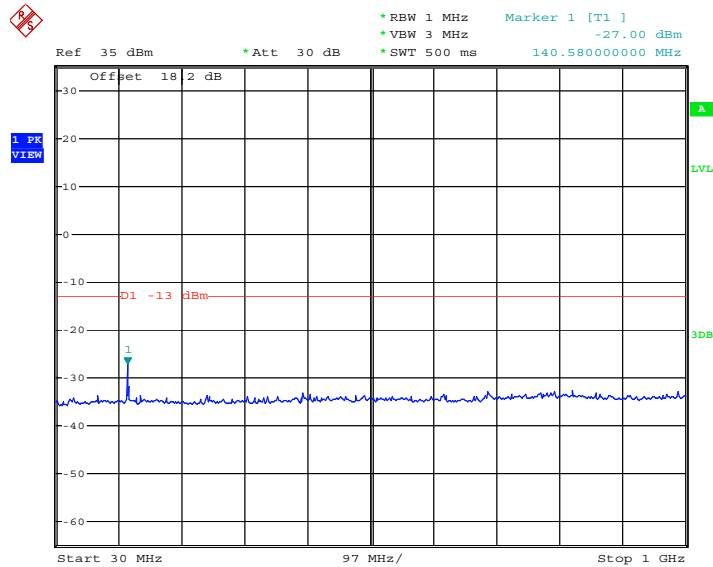

Date: 29.AUG.2008 18:12:42

Conducted Emission Plot between 1GHz ~ 3GHz

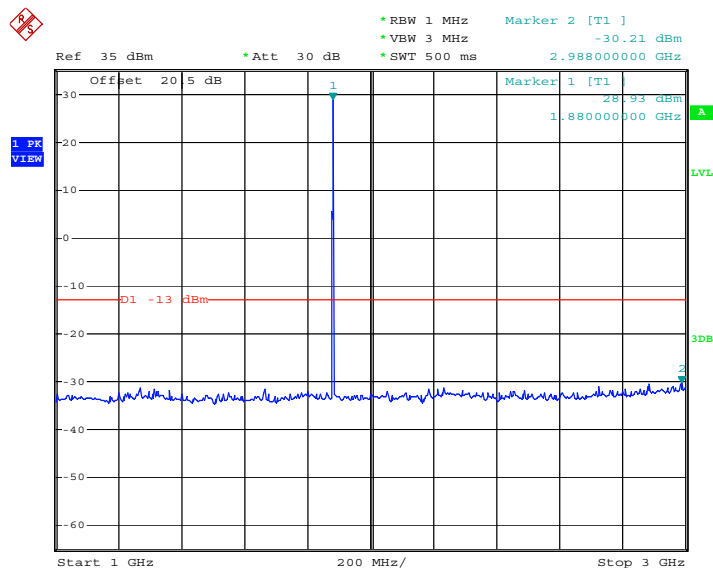

Date: 29.AUG.2008 18:14:32



Conducted Emission Plot between 3GHz ~ 7GHz

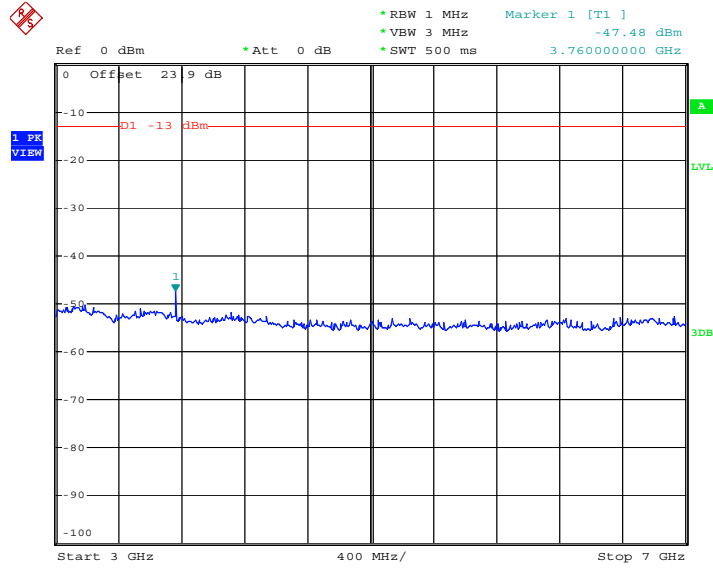

Date: 29.AUG.2008 18:18:57

Conducted Emission Plot between 7GHz ~ 13.6GHz

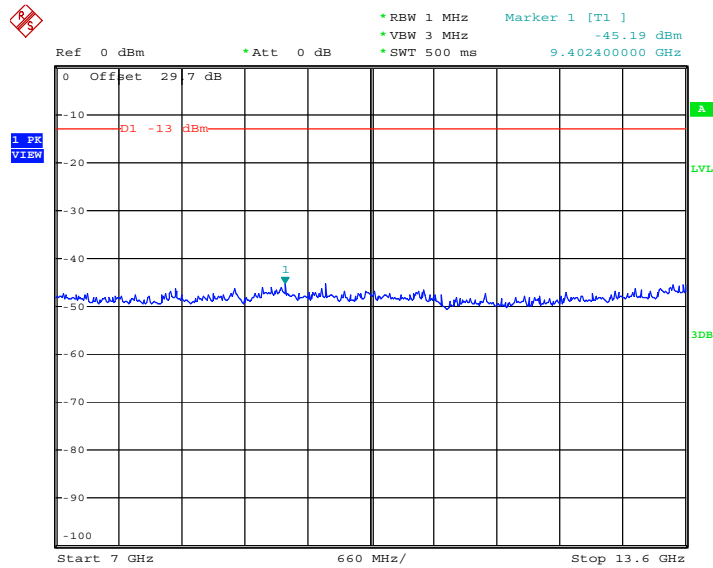

Date: 29.AUG.2008 18:28:03



Conducted Emission Plot between 13.6GHz ~ 19.1GHz

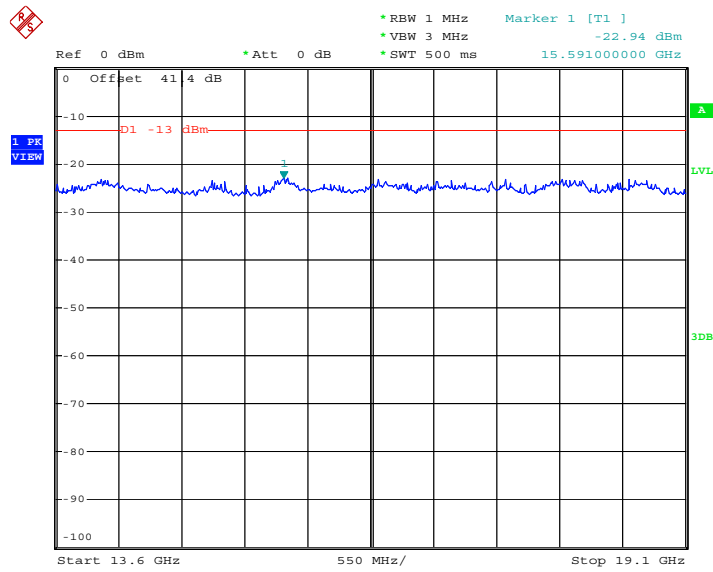

Date: 29.AUG.2008 18:29:05

3.5 Field Strength of Spurious Radiation Measurement

3.5.1 Description of Field Strength of Spurious Radiated Measurement

The radiated spurious emission was measured by substitution method according to ANSI / TIA / EIA-603-C-2004. The power of any emission outside of the authorized operating frequency ranges must be attenuated below the transmitter power (P) by a factor of at least $43 + 10 \log (P)$ dB. The spectrum is scanned from 30 MHz up to a frequency including its 10th harmonic.

3.5.2 Measuring Instruments

See list of measuring instruments of this test report.

3.5.3 Test Procedures

1. The EUT was placed on a rotatable wooden table with 0.8 meter about ground.
2. The EUT was set 3 meters from the receiving antenna, which was mounted on the antenna tower.
3. The table was rotated 360 degrees to determine the position of the highest spurious emission.
4. The height of the receiving antenna is varied between one meter and four meters to search the maximum spurious emission for both horizontal and vertical polarizations.
5. Taking the record of maximum spurious emission.
6. A horn antenna was substituted in place of the EUT and was driven by a signal generator.
7. Tune the output power of signal generator to the same emission level with EUT maximum spurious emission.
8. Taking the record of output power at antenna port.
9. Repeat step 7 to step 8 for another polarization.
10. Emission level (dBm) = output power + substitution Gain.

3.5.4 Test Setup

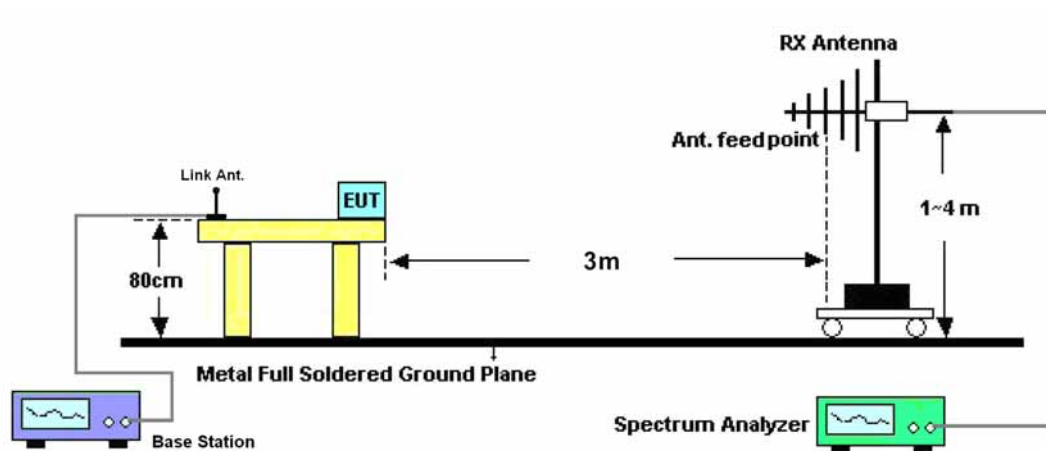



3.5.5 Test Result of Field Strength of Spurious Radiated

Test Band:	GSM 850 / GSM Link	Temperature :	26~28
Channel:	189	Relative Humidity :	50~52%
Test Engineer :	Kay Wu	Polarization :	Horizontal

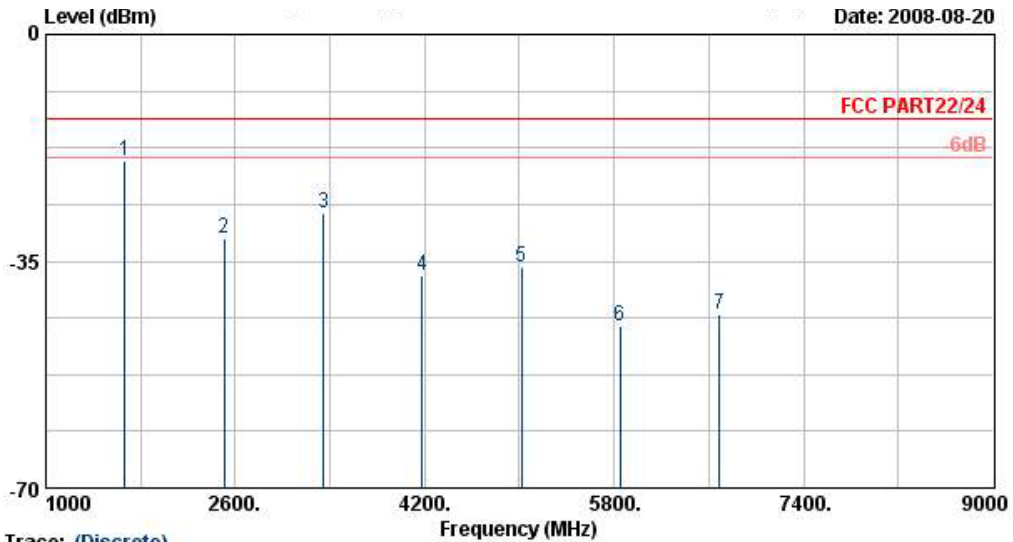

Site : 03CH07-HY
 Condition : HF-EIRP(080306) HORIZONTAL
 Model : FG 880820
 Mode : Mode 1
 Plane : E2

Frequency (MHz)	ERP (dBm)	Limit (dBm)	Over Limit (dB)	SPA Reading (dBm)	S.G. Power (dBm)	TX Cable loss (dB)	TX Antenna Gain (dBi)	Polarization (H/V)	Result
1669	-19.41	-13	-6.41	-27.5	-18.42	3.39	4.55	H	Pass
2506	-31.61	-13	-18.61	-39.09	-31.67	3.71	5.92	H	Pass
3346	-27.71	-13	-14.71	-37.25	-29.64	3.13	7.21	H	Pass
4175	-37.09	-13	-24.09	-49.1	-39.5	3.01	7.57	H	Pass
5015	-35.82	-13	-22.82	-50.79	-39.57	2.61	8.51	H	Pass
5850	-44.99	-13	-31.99	-63.39	-47.44	4.38	8.98	H	Pass
6690	-43.22	-13	-30.22	-65.03	-45.41	5.22	9.56	H	Pass



Test Band:	GSM 850 / GSM Link	Temperature :	26~28
Channel:	189	Relative Humidity :	50~52%
Test Engineer :	Kay Wu	Polarization :	Vertical

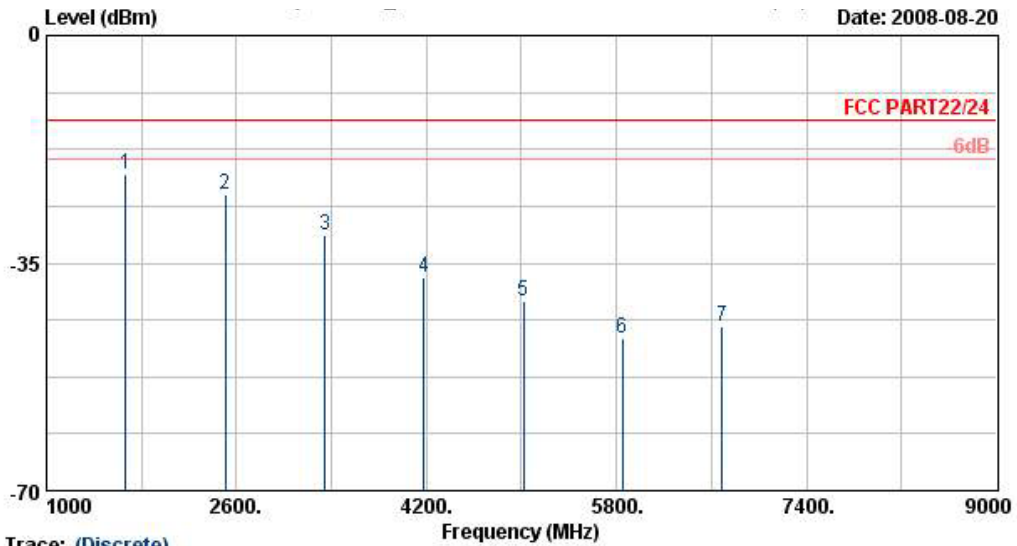

Trace: (Discrete)
 Site : 03CH07-HY
 Condition : HF-EIRP(080306) VERTICAL
 Model : FG 880820
 Mode : Mode 1
 Plane : E2

Frequency (MHz)	ERP (dBm)	Limit (dBm)	Over Limit (dB)	SPA Reading (dBm)	S.G. Power (dBm)	TX Cable loss (dB)	TX Antenna Gain (dBi)	Polarization (H/V)	Result
1669	-21.46	-13	-8.46	-27.96	-20.08	3.39	4.16	V	Pass
2506	-24.55	-13	-11.55	-36.45	-24.41	3.71	5.72	V	Pass
3346	-30.59	-13	-17.59	-43.2	-32.79	3.13	7.48	V	Pass
4175	-37.21	-13	-24.21	-51.75	-40.33	3.01	8.28	V	Pass
5015	-40.95	-13	-27.95	-56.91	-45.31	2.61	9.12	V	Pass
5850	-46.59	-13	-33.59	-64.71	-50.08	4.38	10.02	V	Pass
6690	-44.63	-13	-31.63	-65.85	-47.88	5.22	10.62	V	Pass



Test Band:	GSM 1900 / GSM Link	Temperature :	26~28
Channel:	661	Relative Humidity :	50~52%
Test Engineer :	Kay Wu	Polarization :	Horizontal

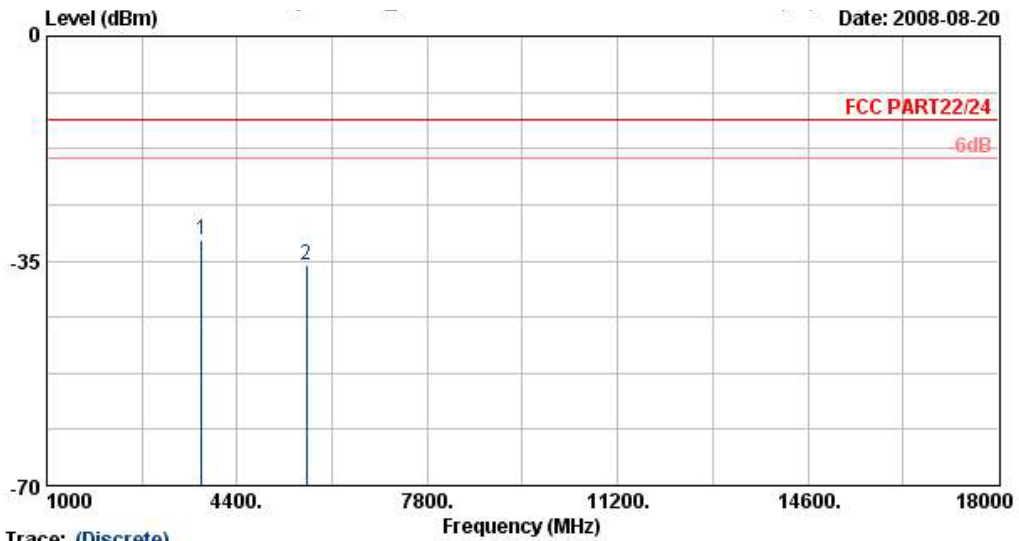

Trace: (Discrete)
 Site : 03CH07-HY
 Condition : HF-EIRP(080306) HORIZONTAL
 Model : FG 880820
 Mode : Mode 1
 Plane : E2

Frequency (MHz)	ERP (dBm)	Limit (dBm)	Over Limit (dB)	SPA Reading (dBm)	S.G. Power (dBm)	TX Cable loss (dB)	TX Antenna Gain (dBi)	Polarization (H/V)	Result
3760	-31.65	-13	-18.65	-47.42	-35.02	4.03	7.40	H	Pass
5636	-35.77	-13	-22.77	-57.23	-40.71	3.87	8.81	H	Pass



Test Band:	GSM 1900 / GSM Link	Temperature :	26~28
Channel:	661	Relative Humidity :	50~52%
Test Engineer :	Kay Wu	Polarization :	Vertical

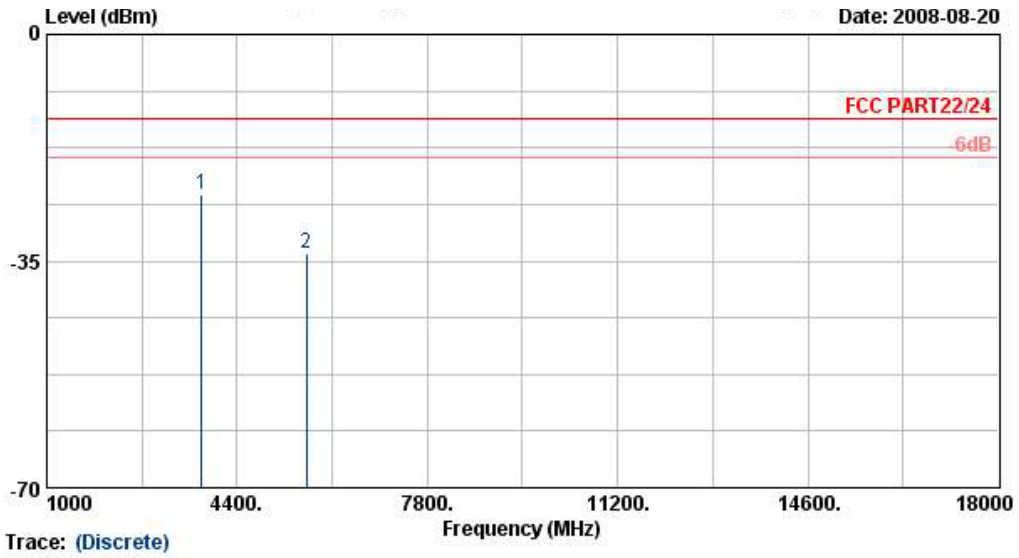

Site : 03CH07-HY
 Condition : HF-EIRP(080306) VERTICAL
 Model : FG 880820
 Mode : Mode 1
 Plane : E2

Frequency (MHz)	ERP (dBm)	Limit (dBm)	Over Limit (dB)	SPA Reading (dBm)	S.G. Power (dBm)	TX Cable loss (dB)	TX Antenna Gain (dBi)	Polarization (H/V)	Result
3760	-24.78	-13	-11.78	-43.89	-28.66	4.03	7.91	V	Pass
5636	-33.84	-13	-20.84	-56.53	-39.74	3.87	9.77	V	Pass

3.6 Frequency Stability Measurement

3.6.1 Description of Frequency Stability Measurement

The frequency stability shall be measured by variation of ambient temperature and variation of primary supply voltage to ensure that the fundamental emission stays within the authorized frequency block. The frequency stability of the transmitter shall be maintained within $\pm 0.00025\%$ ($\pm 2.5\text{ppm}$) of the center frequency.

3.6.2 Measuring Instruments

See list of measuring instruments of this test report.

3.6.3 Test Procedures for Temperature Variation

1. The EUT was set up in the thermal chamber and connected with the base station.
2. With power OFF, the temperature was decreased to -30°C and the EUT was stabilized for three hours. Power was applied and the maximum change in frequency was recorded within one minute.
3. With power OFF, the temperature was raised in 10°C step up to 50°C . The EUT was stabilized at each step for at least half an hour. Power was applied and the maximum frequency change was recorded within one minute.
4. If the EUT can not be turned on at -30°C , the testing lowest temperature will be raised in 10°C step until the EUT can be turned on.

3.6.4 Test Procedures for Voltage Variation

1. The EUT was placed in a temperature chamber at $25\pm 5^{\circ}\text{C}$ and connected with the base station.
2. The power supply voltage to the EUT was varied from BEP to 115% of the nominal value measured at the input to the EUT.
3. The variation in frequency was measured for the worst case.

3.6.5 Test Setup

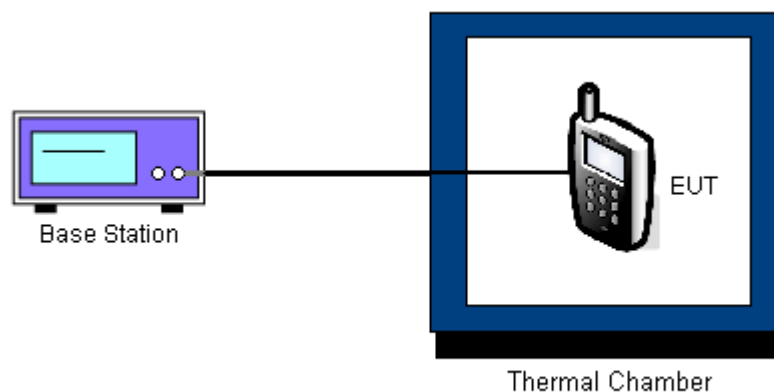



3.6.6 Test Result of Temperature Variation

Band :	GSM 850	Channel :	189
Limit (ppm) :	2.5		

Temperature (°C)	GSM		Result
	Freq. Dev. (Hz)	Deviation (ppm)	
-30	-	-	PASS
-20	-	-	
-10	-13	-0.02	
0	-23	-0.03	
10	-24	-0.03	
20	-20	-0.02	
30	-29	-0.03	
40	-22	-0.03	
50	-28	-0.03	

Remark: EUT could not be turned on at Temperature -30 and -20

Band :	GSM 1900	Channel :	661
Limit (ppm) :	2.5		

Temperature (°C)	GSM		Result
	Freq. Dev. (Hz)	Deviation (ppm)	
-30	-	-	PASS
-20	-	-	
-10	15	0.01	
0	16	0.01	
10	-13	-0.01	
20	-17	-0.01	
30	-23	-0.01	
40	-22	-0.01	
50	-16	-0.01	

Remark: EUT could not be turned on at Temperature -30 and -20



3.6.7 Test Result of Voltage Variation

Band & Channel	Mode	Voltage (Volt)	Freq. Dev. (Hz)	Deviation (ppm)	Limit (ppm)	Result
GSM 850 CH189	GSM	3.7	-17	-0.02	2.5	PASS
		BEP	31	0.04		
		4.2	-19	-0.02		
GSM 1900 CH661	GSM	3.7	-27	-0.01		
		BEP	-17	-0.01		
		4.2	14	0.01		

Remark:

- 1. Normal Voltage = 3.7V.
- 2. Battery End Point (BEP) = 3.3 V.



4 List of Measuring Equipments

Instrument	Manufacturer	Model No.	Serial No.	Characteristics	Calibration Date	Due Date	Remark
Spectrum	R&S	FSP40	100055	9KHz~40GHz	Jun. 26, 2008	Jun. 25, 2009	Conducted (TH02-HY)
Thermal Chamber	TEN BILLION	TTH-D35P	TBN-930701	N/A	Aug. 01, 2008	Jul. 31, 2009	Conducted (TH02-HY)
Bilog Antenna	SCHAFFNER	CBL6111C	2726	30MHz-1GHz	Dec. 01, 2007	Nov. 30, 2008	Radiation (03CH07-HY)
Spectrum Analyzer	R & S	FSP	101067	9KHz~30GHz	Dec. 05, 2007	Dec. 04, 2008	Radiation (03CH07-HY)
Double Ridge Horn Antenna	ESCO	3117	75962	1G~18G	Aug. 13, 2008	Aug. 12, 2009	Radiation (03CH07-HY)
PreAmplifier	Agilent	8449B	3008A02362	1~26.5GHz	Dec. 22, 2007	Dec. 21, 2008	Radiation (03CH07-HY)
PreAmplifier	COM-POWER	PA-103A	161241	10-1000MHz.32 dB.GAIN	Mar. 31, 2008	Mar.30, 2009	Radiation (03CH07-HY)
Double Ridge Horn Antenna	ESCO	3117	66584	1G~18G	Aug. 06, 2008	Aug. 05, 2009	Radiation (03CH07-HY)

5 Uncertainty of Evaluation

Uncertainty of Radiated Emission Measurement (1GHz ~ 40GHz)

Contribution	Uncertainty of x_i		$u(x_i)$	C_i	$C_i * u(x_i)$
	dB	Probability Distribution			
Receiver reading	±0.10	Normal(k=1)	0.10	1	0.10
Antenna factor calibration	±1.70	Normal(k=2)	0.85	1	0.85
Cable loss calibration	±0.50	Normal(k=2)	0.25	1	0.25
Receiver Correction	±2.00	Rectangular	1.15	1	1.15
Antenna Factor Directional	±1.50	Rectangular	0.87	1	0.87
Site imperfection	±2.80	Triangular	1.14	1	1.14
Mismatch Receiver VSWR $\Gamma_1 = 0.197$ Antenna VSWR $\Gamma_2 = 0.194$ Uncertainty = $20 \log(1 - \Gamma_1 * \Gamma_2)$	+0.34/-0.35	U-shaped	0.244	1	0.244
Combined standard uncertainty $U_c(y)$	2.36				
Measuring uncertainty for a level of Confidence of 95% $U = 2U_c(y)$	4.72				

6 Certification of TAF Accreditation

Certificate No. : L1190-070110
財團法人全國認證基金會
Taiwan Accreditation Foundation

Certificate of Accreditation

This is to certify that

Sporton International Inc.
EMC & Wireless Communications Laboratory
No.52, Hwa Ya 1st Rd., Hwa Ya Technology Park, Kwei-Shan Hsiang, Tao Yuan Hsien,
Taiwan, R.O.C.

is accredited in respect of laboratory

Accreditation Criteria	: ISO/IEC 17025:2005
Accreditation Number	: 1190
Originally Accredited	: December 15, 2003
Effective Period	: January 10, 2007 to January 09, 2010
Accredited Scope	: Testing Field, see described in the Appendix
Specific Accreditation Program	: Accreditation Program for Designated Testing Laboratory for Commodities Inspection Accreditation Program for Telecommunication Equipment Testing Laboratory

Jay-San Chen
President, Taiwan Accreditation Foundation
Date : January 10, 2007

PI, total 9 pages

The Appendix forms an integral part of this Certificate, which shall be invalid when used without the Appendix.



Appendix A. Photographs of EUT

Please refer to Sporton report number EP880820 as below.

Appendix B. Setup Photographs

Spurious Radiation

FRONT VIEW

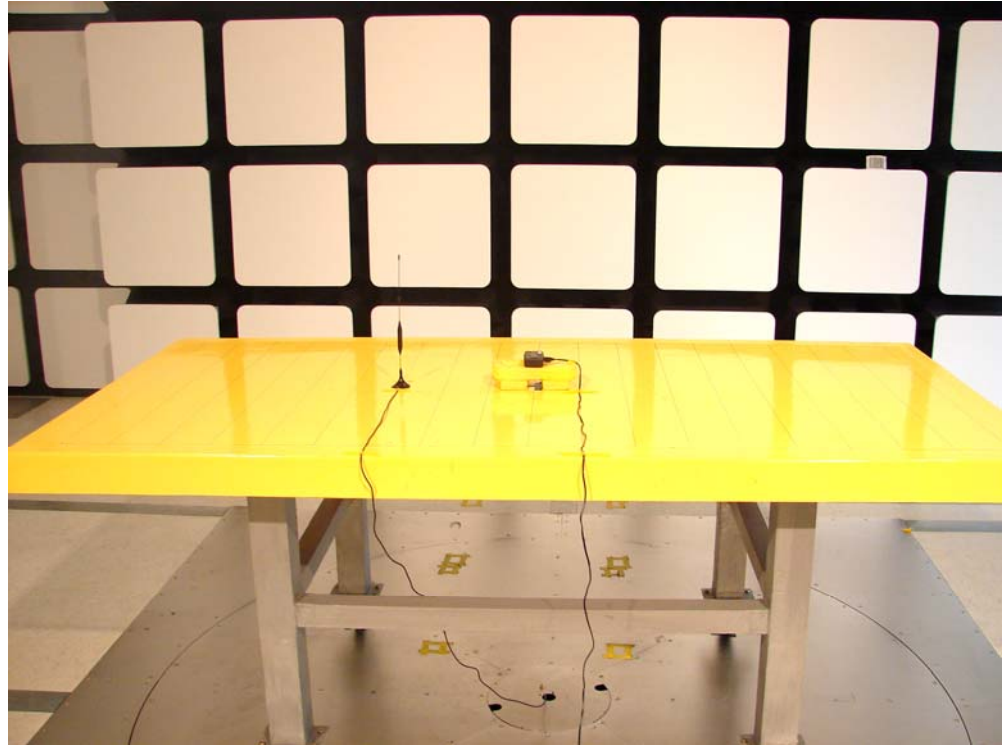

REAR VIEW

