

HOLUX

DFD-100

Hypo-vigilance/

Fatigue Detector

User Manual

Ver. 1.9

Holux Technology Inc.

Safety Precaution

- Due to different conditions and environments when using DFD-100, users must take note of the following information:
 1. DFD-100 has passed rigorous test in detecting driver hypo-vigilance (HPV)/ fatigue. However wrong operation, external interference, or malfunction, may affect the results; users must bear the risk.
 2. When installing the device, ensure correct installation position. When using the device on the road, take safety precautions and assume all responsibilities. HOLUX will not bear any responsibility.
 3. DFD-100 is a standard HPV/ fatigue detection device; it is not suitable for precise measurements.

- Use the power adapter included with the package, using power adapters other than the one provided will result in malfunction and could prove dangerous.

- About the power adapter:
 1. Do not use the power adapter in a wet environment. When hands and feet are wet, do not touch the power adapter.

 2. While using the power adaptor ensure that the area is well ventilated. Do not let paper or other material cover the power adaptor, as this will interfere with cooling. Do not use the power adaptor whilst it is in a bag.

 3. Do not attempt to repair the device. If device is damaged or is in a wet environment, replace the device immediately.

 4. It is not recommended to charge from a PC because the PC power voltage is not enough to

supply the device.

- Suggestion! The user manual should be put in the car to read any time.

Warranty Statement

- This warranty applies to parts and services that are manufactured and sold through Holux Technology Inc. The warranty length is one year from date of purchase (starting from the date on the sales receipt). Under normal user operation, Holux Technology provides free repair services.
- Holux Technology is not responsible for providing repairs or replacements of any software; Holux Technology does not provide any warranty service for third party software/hardware.
- Important instructions
 1. This warranty does not cover damage or malfunction from the below causes:
unauthorized disassembly/modification of unit, abuse or incorrect usage, accidental and other unpreventable causes, operation under variables mentioned that are different from those in this

product user manual, using parts not made or sold by Holux Technology, or repairs done by anyone other than Holux Technology and authorized retail/service providers.

2. Expendable parts are not covered in the warranty.
3. Please contact your local Holux Technology authorized service provider to learn more about geographical limitations, proof of purchase requests, response time agreements, and other specific maintenance service requests.

Copyright Information

No part of this manual, including the products and software described in it, may be reproduced, transmitted, transcribed, stored in a retrieval system, or translated into any language in any form or by any mean, without the express written permission of Holux Technology, Inc.

Copyright, All Rights Reserved.

Technical Support

- If there are any questions regarding the use of this product, please log on to the website www.holux.com and see the FAQ.

Table of Contents

Safety Precaution.....	ii
Warranty Statement.....	v
Product Description	2
Product Caution	4
Product Appearance	5
Wearing and Activating the DFD-100.....	8
Wearing the DFD-100	8
Disable alarm function	13
Unbuckle the seat belt.....	14
DFD-100 Warning signals	15
Warning Sound and LED display	15
Battery and Charging.....	19
LED Power Display	20
FAQ	21
Technical Specifications	23
DFD-100	23
DFD-100 + Bluetooth.....	25

Product Description

According to published studies and test results, the driver's vigilance level decreases (i.e. hypo-vigilance) due to long hours driving on highways. The DFD-100 is a driver hypo-vigilance(HPV)/ fatigue detector that detects driver's heart rate change to determine the driver's HPV/ fatigue . The DFD-100 issues a warning whenever the driver's vigilance level drops below the set-up limit.

The DFD-100 is based on the use of non-contact heart rate sensing technology and a patented HPV/fatigue detection algorithm. No electrode patches in direct contact with the skin are required. The device is fitted to the driver's seat belt and the device is ready to start operating when the driver's seat belt is fastened.

Attention

The DFD-100 is an auxiliary driving safety device. When it emits a warning beep, it means the driver's vigilance level is low due to fatigue . Driver fatigue is as dangerous as drunk driving so when this happens, you should move to the side of the road and stop driving for your own safety.

Product Caution

Do not use the device when you drive on urban road.



Do not over charge.

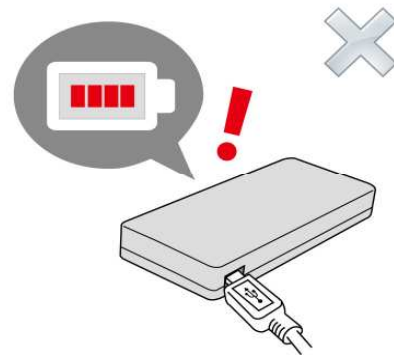

Do not use the device when charging.



Do not place the device under the windshield to solarization.

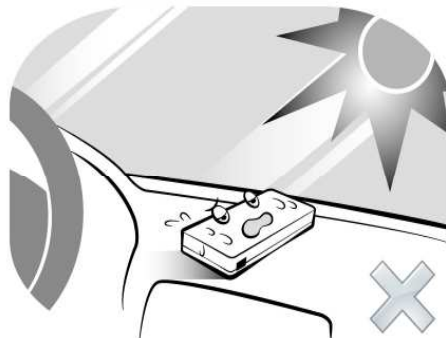

Product Appearance

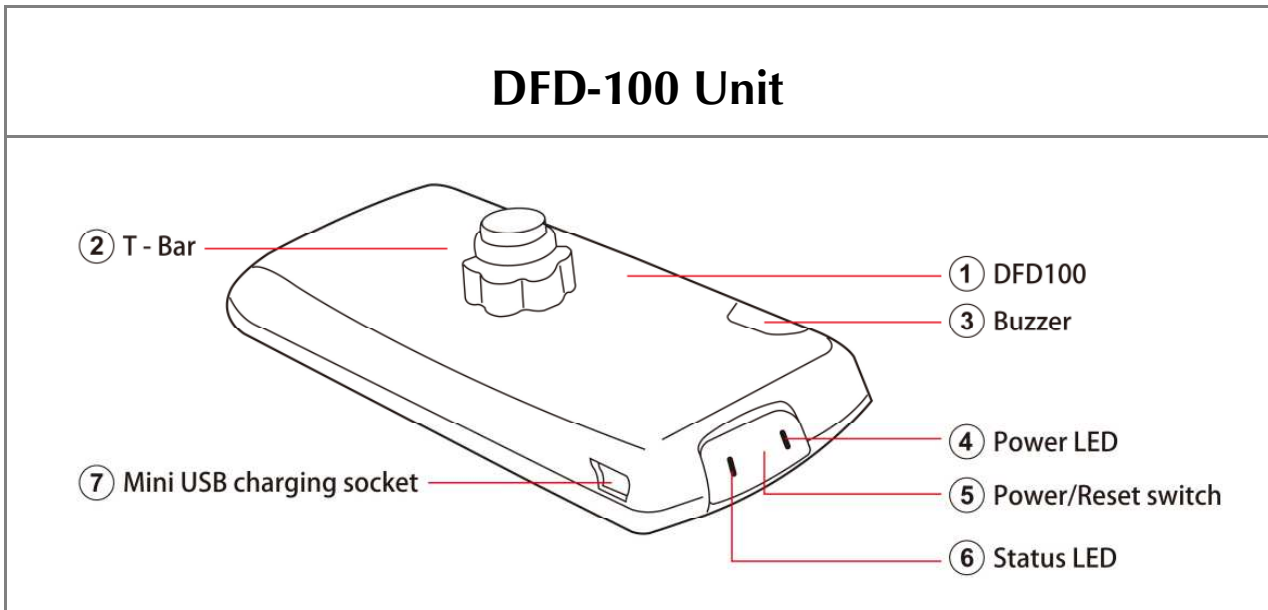

Product Appearance Legend

Item	Part Name	Function and Description
①.	DFD-100 Unit	To use the DFD-100, first secure the Fixer to the seat belt then attach the device to the Fixer via the T-Bar on the back.
②.	T-Bar	This connects the Fixer and the DFD-100. Insert the T-Bar into the T-Bar Mount and then push downwards to clip it securely in place.
③.	Buzzer	Warning beeps are sounded from here.

④.	Power LED	<p>Charging Status – the green LED will be turned on while charging. When fully charged the green light will go out.</p> <p>※ Faces the right side of the driver during use</p>
⑤.	Power Switch	<p>Hold down for 3 seconds to switch the DFD-100 on or off. Once the device is switched on, it will beep once and glow green for 10 seconds to indicate that the device is now running automatically.</p>
⑥.	Status LED	<p>Once the device is switched on the LED will glow green for 10 seconds to indicate that the device is in detection mode.</p> <p>※ Faces the left side of the driver during use</p>
⑦.	Mini USB charging socket	<p>The mini-USB socket can be used to connect to a power supply and charge the device.</p>

Fixer		
Item	Part Name	Function and Description
⑧.	Fixer	The Fixer is used for fitting the DFD-100 to the seat belt.
⑨.	T-Bar Mount	This connects the Fixer and the DFD-100. Insert the T-Bar into the T-Bar Mount and then push downwards to click it into place.

Wearing and Activating the DFD-100

Wearing the DFD-100

Step 1. Attach the DFD-100 Fixer to the seat belt.

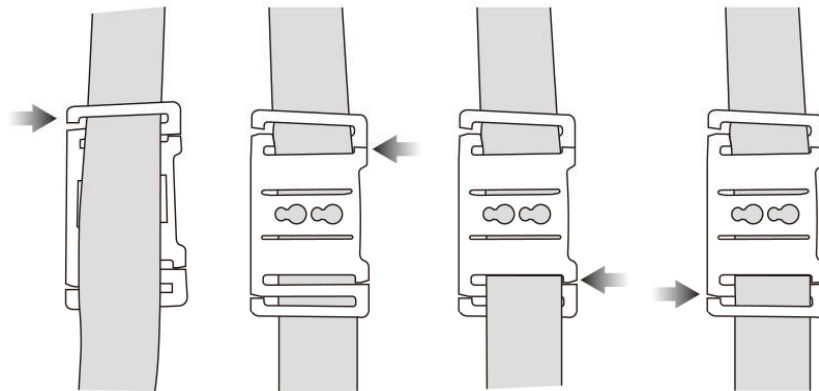

The Fixer should be oriented with the wider end  pointing up. And the convex of Fixer is faced to users.



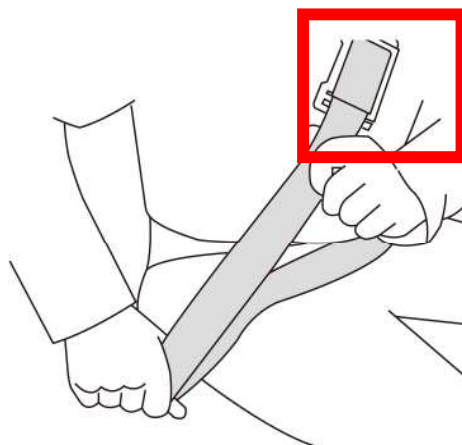

Step 2. Once the Fixer has been fitted to the seat belt, the driver should then put on the seat belt.

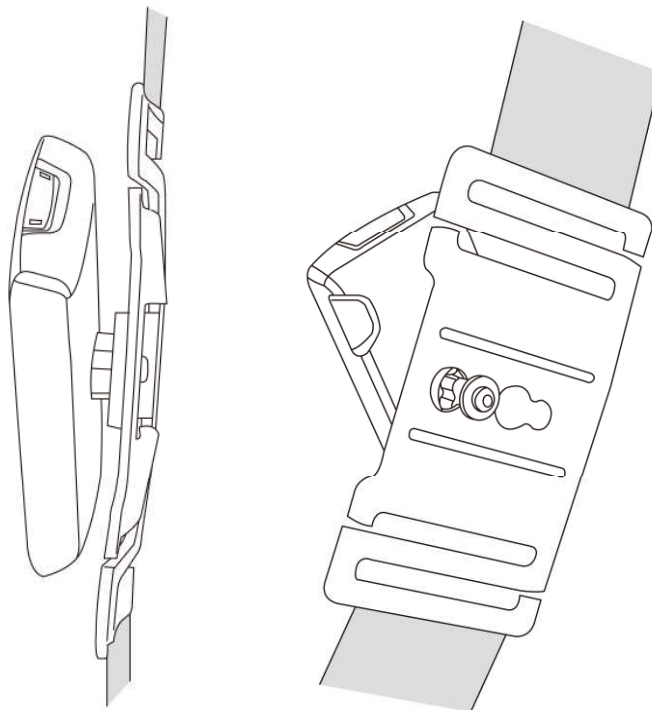

Step 3. Attach the DFD-100 unit to the Fixer.



Attention:

1. The T-Bar on the back of the DFD-100 should be aimed at the wider end of the -shaped hole.
2. The driver should choose an appropriate -shaped hole of the T-Bar Mount for their body shape. Press the T-Bar into the wider end of the -shaped hole and gently rotate around and push downwards to secure it. Make sure that the trough on the T-Bar is clipped into the narrower end of the -shaped hole.

Step 4. Confirm the positioning of the DFD-100.

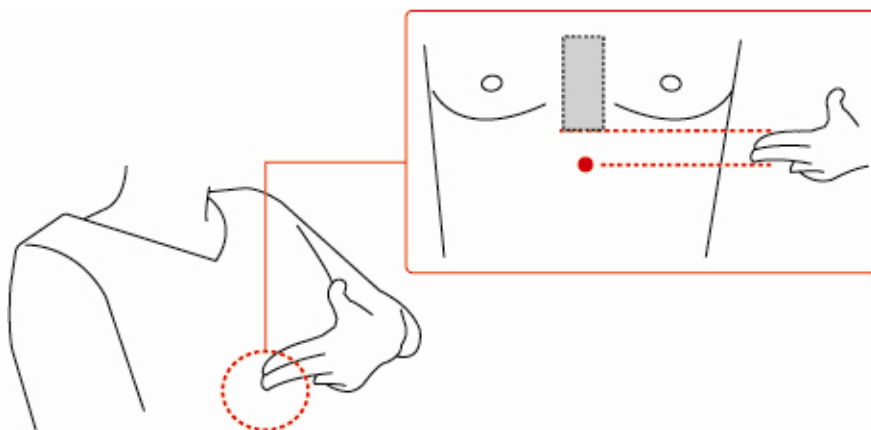

Attention: The front of the DFD-100 must be positioned at the center of the driver's chest with the buttons and light indicators facing upwards. The lower edge of the DFD-100 should be level with a point 2 finger-width up from the xiphoid process of the sternum (indicated spot ●).

※ Because of body type differences, the detection location may slightly differ. If the heart signal cannot be detected from the proposed location, slightly adjust the device location (adjust location as shown below). Please wait 30 seconds ~ 1 minute for DFD-100 to detect the heart signal. When you sound two short beeping means the heart signal is successfully detected.

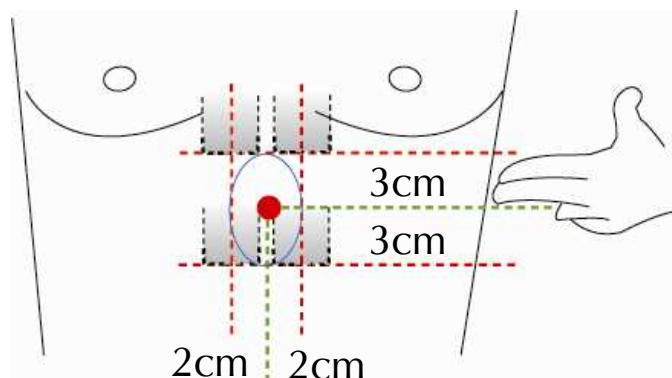

Step 5. Adjust the location of the fixer.

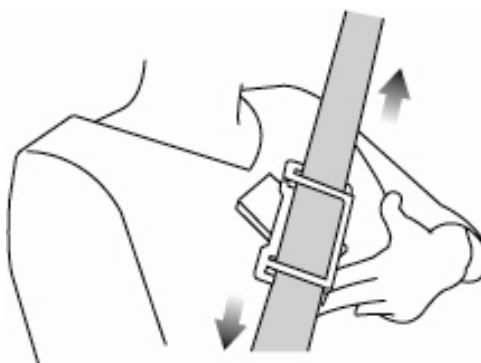

Slide the fixer to adjust the position of the DFD-100.

Step 6. Once the DFD-100 is properly in place turn on the power switch.

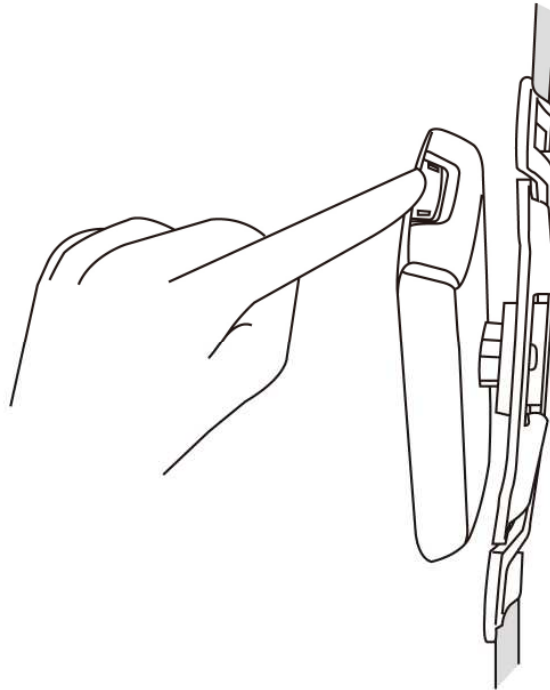

When the DFD-100 is in the right place, hold down the power switch for 3 seconds to turn on the power. Please wait 30 seconds ~ 1minute for DFD-100 to detect the driver's heart signal. Two short beeping sounds indicate that the heart signal is successfully detected.

Attention

Driving on flat stretches of highway during long journeys increases the risk of HPV/fatigue. This device is intended primarily to be used when the driver is on a highway to avoid accidents.

Disable alarm function

When DFD-100 emits audio alarms, you can choose to silence it by pressing down the power switch once. If you choose to silence it twice within one minute period, the previous data will be erased and DFD-100 will reset the detector function.

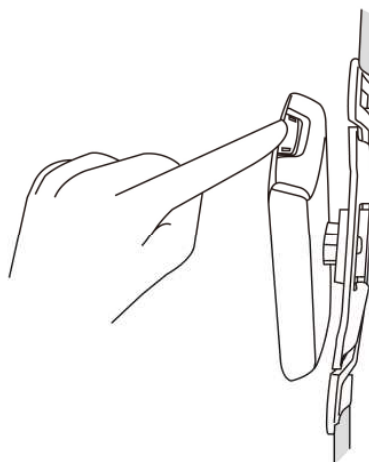

Unbuckle the seat belt

Step 1. Sliding downwards the Fixer and DFD-100.

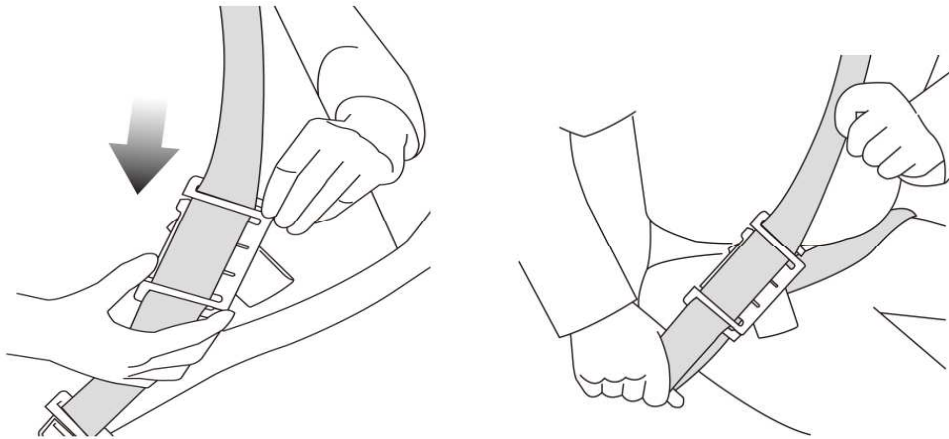

Step 2. Unbuckle the seat belt; let the seat belt and DFD-100 smoothly slide back.

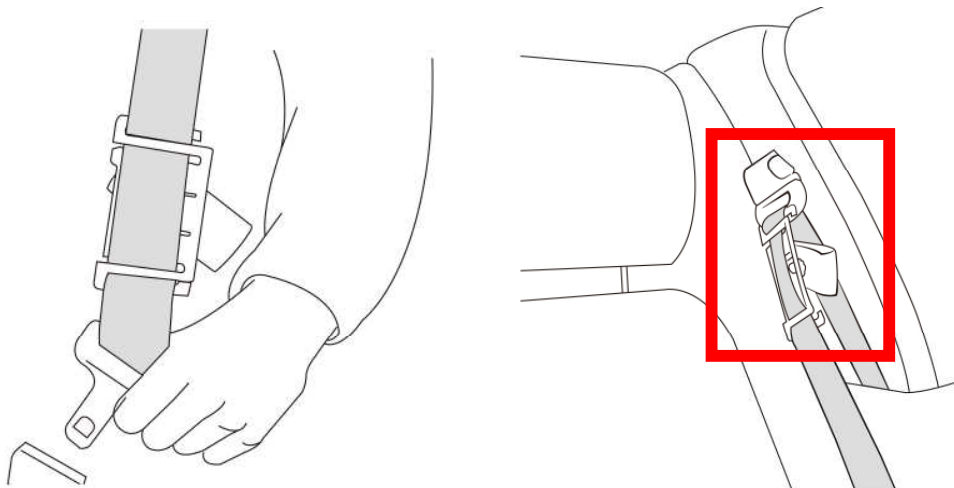

DFD-100 Warning signals

Warning Sound and LED display

The HPV/fatigue detected function is not enabled:

Action	Power switch	Warning Sound-Beep	Status LED	Power LED
Switch on	Hold down 3 sec.	●—	★—	-
No heartbeat detected	-	● (at 5 sec. interval)	★ (at 5 sec. interval)	-

● = 1 short Beep; ●— = 1 long Beep

★— = Green on 10 sec.; ★ = Red flash 1

The HPV/fatigue detected function is enabled:

Action	Warning Sound- Beep	Status LED	Power LED
Heartbeat detected after device was switched on.	●●	-	-
Heartbeat detected correctly	-	★ (at 2 sec. interval)	-
Driver is becoming fatigue.	●—●—●—	★★★	-

●● = 2 short Beep; ●—●—●— = 3 long Beep;

★ = Green flash 1; ★★★ = Red flash 3

Action	Power switch	Warning Sound- Beep	Status LED	Power LED
Auto power off	-	●●●●	-	-
User Power off	Hold down 3 sec.	●—	★—	-
Low Power	-	●●●	★★★ (at 30 sec. interval)	★—
Bad Signal quality	-	●	★—	-

●●●● = 4 short Beep; ●— = 1 long Beep;

●●● = 3 short Beep; ● = 1 short Beep

★— = Red on; ★★★ = Red flash 3;

★— = Red on 5 sec

Attention

- ※ If the driver's heartbeat signal is too faint for the DFD-100 to detect, the DFD-100 will switch off 1 minute after it loses the heartbeat signal.
- ※ Bad signal quality means the detected signal is abnormal within 30 seconds continuously, such as: shake body long time or wrong detected position.

Battery and Charging

1. Charging with the Cigarette Lighter

The USB car charger can be used to connect the DFD-100 to the car's cigarette lighter for charging.

※ Do not use the device when charging.

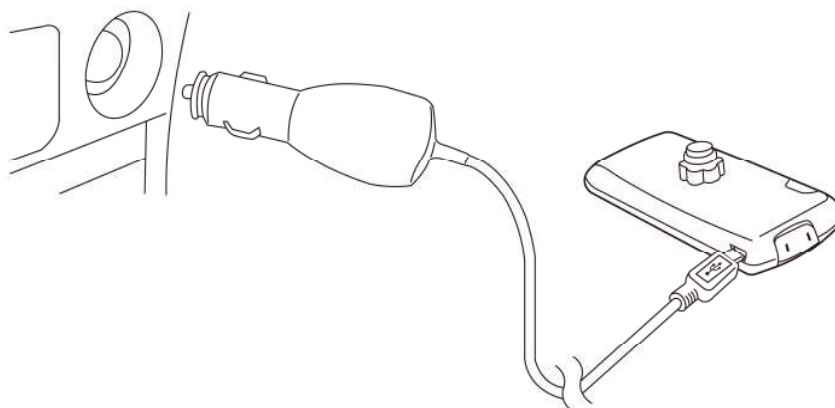

2. Charging with standard USB

Connect the mini-USB transformer directly to a standard power socket to start charging.

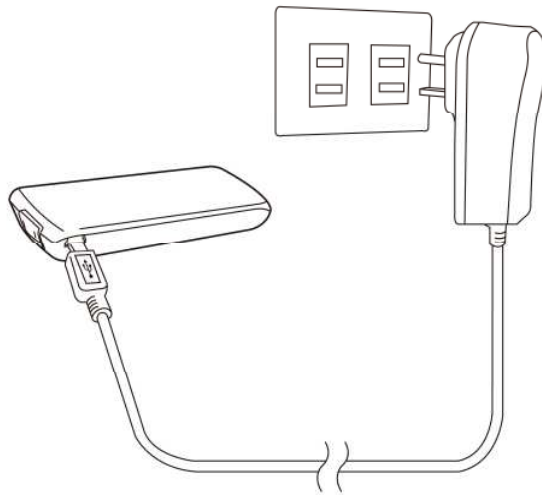

LED Power Display

Action	Status	Status LED	Power LED display
Plugged power	Charging	-	***...
Plugged power	Fully Charged	-	*———

***... = Green flash Continuously (1sec interval);

*——— = Green on

FAQ

1. Why can't I use DFD-100 when charging in the car?

The accessory of DFD-100 is included a car charger for your convenience to charge in the car. Due to driving safety, avoid distractions and the accuracy of fatigue detection; do not use DFD-100 when charging in the car.

2. Does DFD-100 have an instable detection in the winter?

The DFD-100 detects driver's heart rate change to determine the driver's fatigue level. The best distance between the device and the skin is less than 5mm.

Suggestion: Do not wear heavy clothing when using the device that in hence the accuracy of detection.

3. Does the fixer need to be attached and took off when I use the device every time?

At first time; please attach the DFD-100 fixer to the seat belt. When finished, you don't need to take off

the fixer; it can slide back with seat belt.

Technical Specifications

DFD-100

Fatigue	- Accuracy 90%
Detection	- False alarm rate Less then 1%
Dimensions	8.6 x 5.6 x 2.0 cm
Power (PCB version)	- 3.7 Volt, 770 mAh, rechargeable lithium battery - 8 hours of continuous usage - Charging time: 4 hours (Charge the battery for 8 hours before using this device for the first time.)
Key	1 key for power/ reset switch
I/O interface	Mini USB for charging
Environmental specifications	- Operating Temperature: -10°C to 60°C - Storage Temperature: -20% to 70% - Charging Temperature: 0°C to 45°C - Humidity: 30 to 90%
Complies with IEC61000 & JAP WEPE electromagnetic	

compatibility of general industrial products.

Certificate number :

EN 55011: 2009 + A1: 2010

EN 61000-3-2: 2006 + A2: 2009

EN 61000-3-3: 2008

EN 60601-1-2: 2007

IEC 61000-4-2 Ed. 2.0: 2008

IEC 61000-4-3 Ed. 3.2: 2010

IEC 61000-4-4 Ed. 2.1: 2011

IEC 61000-4-5 Ed. 2.0: 2005

IEC 61000-4-6 Ed. 3.0: 2008

IEC 61000-4-8 Ed. 2.0: 2009

IEC 61000-4-11 Ed. 2.0: 2004

FCC Part 18: 2010

DFD-100 + Bluetooth

Fatigue Detection	<ul style="list-style-type: none"> - Accuracy 90% - False alarm rate Less then 1%
Dimensions	8.6 x 5.6 x 2.0 cm
Power (PCB version)	<ul style="list-style-type: none"> - 3.7 Volt, 770 mAh, rechargeable lithium battery - 8 hours of continuous usage - Charging time: 4 hours <p>(Charge the battery for 8 hours before using this device for the first time.)</p>
Key	1 key for power/ reset switch
I/O interface	Mini USB for charging
Bluetooth module (DFD-100 BT only)	<p>Profile: SPP</p> <p>Power: 3.3Vdc 65mA</p> <p>RF Class type: class II</p> <p>Baud rate: 57600 bps</p> <p>Parity check: None</p> <p>Data bits: 8 bits</p> <p>Stop bit: 1bit</p> <p>(The Bluetooth function is for engineer use only.)</p>

Environmental specifications	<ul style="list-style-type: none">- Operating Temperature: -10°C to 60°C- Storage Temperature: -20% to 70%- Charging Temperature: 0°C to 45°C- Humidity: 30 to 90%
<p>Complies with IEC61000 & JAP WEPE electromagnetic compatibility of general industrial products.</p> <p>Certificate number:</p> <p>EN 55011: 2009 + A1: 2010</p> <p>EN 61000-3-2: 2006 + A2: 2009</p> <p>EN 61000-3-3: 2008</p> <p>EN 60601-1-2: 2007</p> <p>IEC 61000-4-2 Ed. 2.0: 2008</p> <p>IEC 61000-4-3 Ed. 3.2: 2010</p> <p>IEC 61000-4-4 Ed. 2.1: 2011</p> <p>IEC 61000-4-5 Ed. 2.0: 2005</p> <p>IEC 61000-4-6 Ed. 3.0: 2008</p> <p>IEC 61000-4-8 Ed. 2.0: 2009</p> <p>IEC 61000-4-11 Ed. 2.0: 2004</p> <p>FCC Part 18: 2010</p> <p>FCC Part 15.247: 2010</p>	

Bluetooth- class2 BT2.0 Module

	Frequency (GHz)	Min	Typ	Max	BT Spec.	Unit
Sensitivity at 0.1%BER	2.402	-	-80	-86	≤ -70	dBm
	2.441	-	-80	-86		dBm
	2.480	-	-80	-86		dBm
RF Transmit Power	2.402	-	0	-	≤ 0	dBm
	2.441	-	0	-		dBm
	2.480	-	0	-		dBm
Initial Carrier Frequency tolerance	2.402	-	5	75	75	kHz
	2.441	-	5	75		kHz
	2.480	-	5	75		kHz
20dB bandwidth for modulated carrier		-	900	1000	≤ 1000	kHz
Drift (Five slots packet)		-	15	-	40	kHz
Drift Rate		-	13	-	20	kHz
Δf_{1avg} "Maximum Modulation"	2.402GHz	140	165	175	$140 < \Delta f_{1avg}$	kHz
	2.441GHz	140	165	175		kHz
	2.480GHz	140	165	175		kHz
Δf_{2max} "Minimum Modulation"	2.402GHz	115	190	-	115	kHz
	2.441GHz	115	190	-		kHz
	2.480GHz	115	190	-		kHz

Federal Communications Commission (FCC) Statement

This equipment has been tested and found to comply with the limits for a Class B digital device, pursuant to Part 15 of the FCC Rules. These limits are designed to provide reasonable protection against harmful interference in a residential installation. This equipment generates, uses and can radiate radio frequency energy and, if not installed and used in accordance with the instructions, may cause harmful interference to radio communications. However, there is no guarantee that interference will not occur in a particular installation. If this equipment does cause harmful interference to radio or television reception, which can be determined by turning the equipment off and on, the user is encouraged to try to correct the interference by one of the following measures:

- Reorient or relocate the receiving antenna.
- Increase the separation between the equipment and receiver.
- Connect the equipment into an outlet on a circuit different from that to which the receiver is connected.
- Consult the dealer or an experienced radio/TV technician for help.

FCC Caution: Any changes or modifications not expressly approved by the party responsible for compliance could void the user's authority to operate this equipment.

This device complies with Part 15 of the FCC Rules. Operation is subject to the following two conditions: (1) This device may not cause harmful interference, and (2) this device must accept any interference received, including interference that may cause undesired operation.

This equipment complies with FCC RF radiation exposure limits set forth for an uncontrolled environment. To maintain compliance with FCC RF exposure compliance requirements, please avoid direct contact to the transmitting antenna during transmitting.

" This equipment must be installed and operated in accordance with provided instructions and the antenna(s) used for this transmitter must be installed to provide a separation distance of at least 20 cm from all persons and must not be co-located or operating in conjunction with any other antenna or transmitter. End-users and installers must be provide with antenna installation instructions and transmitter operating conditions for satisfying RF exposure compliance. "