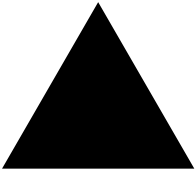

Altitude 300-2™

Getting Started Guide

Extreme Networks, Inc.
3585 Monroe Street
Santa Clara, California 95051
(888) 257-3000
<http://www.extremenetworks.com>
Published: September 2003
Part number: 120175 Rev. 01

©2003 Extreme Networks, Inc. All rights reserved. Extreme Networks and BlackDiamond are registered trademarks of Extreme Networks, Inc. in the United States and certain other jurisdictions. ExtremeWare, ExtremeWare Vista, ExtremeWorks, ExtremeAssist, ExtremeAssist1, ExtremeAssist2, PartnerAssist, Extreme Standby Router Protocol, ESRP, SmartTraps, Alpine, Summit, Summit1, Summit4, Summit4/FX, Summit7i, Summit24, Summit48, Summit300, Summit Virtual Chassis, Altitude 300-2™, SummitLink, SummitGbX, SummitRPS and the Extreme Networks logo are trademarks of Extreme Networks, Inc., which may be registered or pending registration in certain jurisdictions. The Extreme Turbodriven logo is a service mark of Extreme Networks, which may be registered or pending registration in certain jurisdictions. Specifications are subject to change without notice.

All other registered trademarks, trademarks and service marks are property of their respective owners.



Contents

Introduction	5
Related Publications	6
Conventions	6
Overview	9
Hardware Description	10
Altitude 300-2™ Models And Connections	10
<i>Radio Characteristics</i>	11
<i>LED Indicators</i>	12
<i>Package Checklist</i>	13
<i>Optional Equipment Not Supplied</i>	13
Software Description	14
Installation Steps	15
Altitude 300-2™ and Mounting Hardware	17
<i>Universal Mounting Bracket</i>	17
<i>T-Bar Fasteners and Spacers</i>	20
<i>Optional Antenna Shrouds</i>	22
<i>Optional Plastic Cover</i>	23
<i>Painting The Plastic Cover</i>	24
<i>Ordering The Plastic Cover Kit</i>	24
External Antennas	24
Placement of the Wireless Port	25
<i>Mounting Locations</i>	25
<i>Mounting Below A Hard Ceiling</i>	25
<i>Mounting Below A Hanging Ceiling</i>	26
<i>Mounting Above The Hanging Ceiling</i>	27
<i>Mounting On A Wall</i>	28

<i>Mounting On A Table Or Shelf</i>	29
Appendix A: Specifications	31
General Specifications	31
<i>Maximum Number Of Tunable Channels</i>	31
Appendix B: Maximum Distance Table	35
Appendix C: Integrated Dual Band Antenna Pattern	37
Appendix D: Regulatory Compliances	39
Overview	39
General Compliance Design Guidelines	40
North America	42
<i>United States - FCC Declaration of Conformity Statement</i>	42
<i>Department of Communications Canada Compliance Statement</i>	44
European Community & Other Countries	45
<i>Declaration of Conformity with regard to R&TTE Directive of the European Union 1999/5/EC</i>	45
Conditions of Use in the European Community	47
<i>Other Country Specific Compliance Standards, Approvals and Declarations</i>	49
Japan	49
Appendix E: Power Over Ethernet Connector Pin Assignments	51
Appendix F: Terminology	53

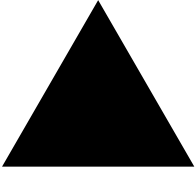

Figures

1	Rear View Of Altitude 300-2i™	10
2	Rear View Of Altitude 300-2d™	10
3	Altitude 300-2™ LED Indicators, Without Plastic Cover	12
4	Universal Mounting Bracket	18
5	Mounting The Wireless Port On The Universal Mounting Bracket	19
6	Installation On A Hanging Ceiling	20
7	Installation Of Optional Spacer	21
8	Antenna Shroud	22
9	Antenna Shroud Installation	22
10	Plastic Cover Installation	23
11	Above The Ceiling Box Hanger Mount	28
12	Antenna Radiation Patterns	37
13	Antenna Radiation Pattern Reference Diagram	38
14	Ethernet Connector Pin Number Assignment	51

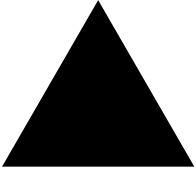

Tables

1	Notice Icons	6
2	LED Indicator Functions	12
3	802.11a Radio	34
4	802.11b/g Radio	34
5	802.11a Maximum Distances	35
6	802.11b Maximum Distances	35
7	802.11g Maximum Distances	36
8	Integrated Antenna Electrical Specification	37
9	Regulator Domain Product Listing	40
10	FCC Conformance Standards	43
11	Canada Conformance Standards	44
12	European Conformance Standards	45
13	Declaration of Conformity in Languages of the European Community	46
14	Other Country Specific Compliance Standards, Approvals and Declarations	49
15	Operation Using 5 GHz Channels in the Japan Community	49
16	Altitude 300-2TM Power Over Ethernet RJ-45 Pin Assignments	51

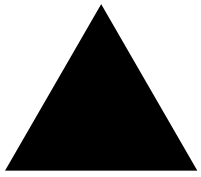

Preface

This preface provides an overview of this guide, describes guide conventions, and lists other publications that might be useful.



NOTE

To ensure proper operation of your Extreme Networks equipment, read this guide before you install any Extreme Networks equipment.

Introduction

This guide provides the required information to install the Altitude 300-2™ wireless port. It also contains general product information about the Altitude 300-2™.

This guide is intended for use by network administrators who are responsible for installing and setting up network equipment. It assumes a basic working knowledge of:

- Local Area Networks (LANs)
- Ethernet concepts
- Simple 802.11 wireless LAN concepts.

See the ExtremeWare Software User Guide for information about configuring an Extreme Networks device.

**NOTE**

If the information in the Release Notes that shipped with your switch differs from the information in this guide, follow the Release Notes.

Related Publications

The Extreme Networks wireless port documentation set includes:

- Altitude 300-2™ Getting Started Guide (this guide)
- Unified Access Deployment Guide.
- ExtremeWare Software User Guide



Documentation for Extreme Networks products is available on the World Wide Web at the following location:

<http://www.extremenetworks.com/>

Conventions

Table 1 lists conventions that are used throughout this guide.

Table 1: Notice Icons

Icon	Notice Type	Alerts you to...
	Note	Important features or instructions.
	Caution	Risk of personal injury, system damage, or loss of data.
	Warning	Risk of severe personal injury.

Documentation for Extreme Networks products is available from the Extreme Networks website at the following location:

<http://www.extremenetworks.com/services/documentation/>

You can select and download the following Extreme Networks documentation from the Documentation section of the Services page:

- Release Notes
- Software
- Hardware
- Reports
- White Papers
- Troubleshooting Tools
- Preventative Maintenance
- Instructional Videos
- Archives

You can also purchase Extreme Networks documentation from the Extreme Networks website.

1

Altitude 300-2™ Wireless Port Introduction

Overview

The Altitude 300-2™ dual-band wireless port provides transparent, high-speed data communications between the Summit 300™ family of wired LAN products and wireless fixed, portable or mobile devices equipped with 802.11a, and 802.11b/g adapters.

The Altitude 300-2™ is part of Extreme Network's Unified Access Architecture. When connected to the Summit 300-48™ it provides a wireless network that is completely integrated into the enterprise network. As part of the Unified Access Architecture, the management of Altitude 300-2™ and Summit 300-48™ is a seamless extension of Extreme Networks' centralized management system, EPICenter™. This integrated network provides unified security, scalability and manageability.

Hardware Description

Altitude 300-2™ Models And Connections

The Altitude 300-2™ wireless port box comes in two models. The first, the Altitude-2i™, is a unit with integrated, dual band antennas and the second, the Altitude-2d™, is a unit with external antenna connectors. Both models have the same radios and overall feature set. Altitude-2i™ is for indoor deployment only. Altitude-2d™, together with an Extreme Networks external antenna, may be configured as indoor use where both the Altitude-2d™ and the external antenna are deployed indoor, or as outdoor use where the Altitude-2d™ is installed indoor and the external antenna is placed outdoor.

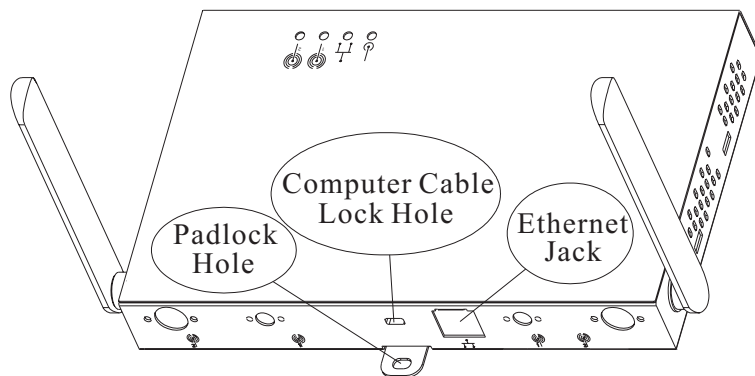

Figure 1: Rear View Of Altitude 300-2i™

Figure 1 shows the rear side of the integrated antenna model of the Altitude 300-2i™. The Ethernet cable is plugged into the RJ45 jack. It supplies both network connectivity and power to the unit. The Altitude 300-2i™ can be locked by either a standard computer cable lock inserted in to hole or a padlock in hole.

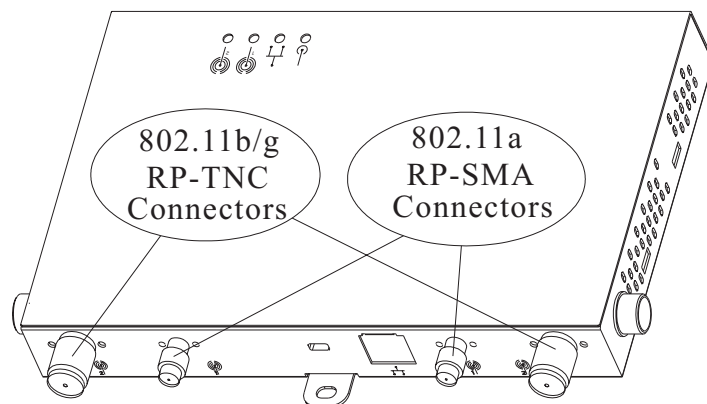

Figure 2: Rear View Of Altitude 300-2d™

Figure 2 shows the back of the external antenna model of the Altitude 300-2d™. Like the other model there is an Ethernet RJ45 jack, a standard computer cable lock hole and padlock hole. Connectors for external antennas are on the back of the unit. The two RP-TNC connectors attach to 802.11b/g antennas and the two RP-SMA connectors attach to 802.11a antennas. Two connections are provided for each radio to support signal diversity.

Radio Characteristics

The Altitude 300-2™ has two radios. The first supports IEEE 802.11a standard that uses a radio modulation technique known as Orthogonal Frequency Division Multiplexing (OFDM). It operates in the 5 GHz region. Data is transmitted over a half-duplex radio channel operating at up to 54 Megabits per sec.

The second radio has two modulation modes both using half-duplex access. The first modulation mode, Direct Sequence Spread Spectrum (DSSS), is used with IEEE 802.11b clients. It operates up to 11 Mbps. The second modulation, OFDM, is used with IEEE 802.11g clients. Like 802.11a it operates up to 54 Mbps. These modulations use the 2.4 GHz band. In this band the Altitude 300-2™ detects what clients are present and selects the modulation mode.

Radios for both bands support antenna diversity. The Altitude 300-2i™ has two integrated antennas. These antennas are dual band, operating simultaneously in the 2.4 GHz and 5 GHz bands. The Altitude 300-2d™ has external antenna connectors that support attachable antennas that operate in the 2.4 GHz and 5 GHz bands.

CAUTION

External antennas must be certified by Extreme Networks or selected by a professional installer to insure they meet all regulatory requirements.

NOTE

The Altitude 300-2d™ is designed for diversity with two antenna connectors for each radio. It is important for the proper operation of the wireless port that antennas be installed on each connector.

LED Indicators

The Altitude 300-2™ includes four status LED indicators visible on the basic box or through the light pipes of the plastic cover. They are depicted and described in the Figure 3 and Table 1.



Figure 3: Altitude 300-2™ LED Indicators, Without Plastic Cover

Table 2: LED Indicator Functions

LED Symbol	LED Name	Color	Status	Description
	Power	Amber & Green	Off	No power
			Amber On	Self test fault found
			Green Flashing	Indicates loading software program
			Green On	The unit is operational.
	LAN	Green	Off	No Ethernet link or the link is disabled
			On	Indicates a valid 10/100 Mbps Ethernet cable link.
			Flashing	Indicates that the wireless port is transmitting or receiving data on a 10/100 Mbps Ethernet LAN. Flashing rate is proportional to the link's activity.
	Radio 1	Green	Off	Disabled or no BSS constructed
			On	802.11a BSS constructed and no activity
			Flashing	Indicates that the wireless port is transmitting or receiving data through the 802.11a radio. Flashing rate is proportional to network activity.
	Radio 2	Green	Off	802.11b/g Disabled or no BSS constructed
			On	802.11b/g BSS constructed and no activity
			Flashing	Indicates that the wireless port is transmitting or receiving data through the 802.11b/g radio. Flashing rate is proportional to network activity.

Package Checklist

The Altitude 300-2™ wireless port package includes:

- One Altitude 300-2™ wireless port (Altitude 300-2i™ or Altitude 300-2d™)
- One short Ethernet straight cable
- Altitude 300-2™ Getting Started Manual (this document)
- One universal mounting bracket
- Two T-Bar ceiling fasteners and fastener nuts
- Two T-Bar fastener spacers
- Four #8x1 inch (25.4 mm) mounting screws and plastic anchors
- Four stick-on feet
- Two cable ties to secure the Altitude 300-2™ to the universal mounting bracket
- One 10-24 nut

The optional plastic cover kit not included here contains:

- Five Altitude 300-2™ plastic covers (15482- translucent, 15483- cool gray, 15484- cream).
- Ten antenna shrouds for use with the Altitude 300-2i™.
- An installation guide sheet.

If possible, retain the carton, including the original packing materials. Use them again to repack the product in case there is a need to return it.

Optional Equipment Not Supplied.

- One padlock for securing the Altitude 300-2™ to the universal mounting bracket. The lock hasp is compatible with a Master Lock 120T lock or a like model.



WARNING!

The Altitude 300-2™ is not secured to the bracket unless a padlock is used. If a padlock is not used the unit should be secured to the bracket by a cable tie through the lock hasp to keep it from falling. Failure to secure the unit is hazardous.

- One computer lock cable for securing the Altitude 300-2™ when the universal mounting bracket is not used.
- Box hanger for installing the Altitude 300-2™ above the tiles of a suspended ceiling.
- External antenna(s) for the Altitude 300-2d™. Extreme Networks' external antennas can be ordered separately.

Software Description

The Altitude 300-2™ receives its software and configuration from the Summit 300™ switch. A description of the software and the wireless port's configuration is in the Summit 300™ manual.

2

Hardware Installation

Installation Steps

- 1 For wall and ceiling installations the universal mounting bracket is used. If unit is being mounted on a table or shelf skip to step 4. Locate and install the universal mounting bracket. Refer to the instructions for the various ceiling installation options (*Mounting Below A Hard Ceiling* on page 25, *Mounting Below A Hanging Ceiling* on page 26, and *Mounting Above The Hanging Ceiling* on page 27) and the wall mounting option (*Mounting On A Wall* on page 28) in the next section.
- 2 Mount the Altitude 300-2™ on the universal mounting bracket. The Altitude 300-2™ has three slotted mounting holes on the back of the unit. The mounting studs on the universal mounting bracket fit into the slotted mounting holes. The unit slides all the way forward into these holes. The lock hasp hole on the Altitude 300-2™ should line up with the lock hasp hole on the universal mounting bracket when the unit is slid all the way forward, see Figure 5: Mounting The Wireless Port On The Universal Mounting Bracket on page 19.
- 3 Lock and secure the Altitude 300-2™. The Altitude 300-2™ and the universal mounting bracket are designed to use a Master Lock 120T or similarly sized padlock to secure the wireless port from theft of from coming off the bracket, see Figure 5: Mounting The Wireless Port On The Universal Mounting Bracket on on page 19. Wall and ceiling installations skip step 4.



WARNING!

The Altitude 300-2™ is not secured to the bracket unless a padlock is used. If a padlock is not used the unit should be secured to the bracket by a cable tie through the lock hasp to keep it from falling. Failure to secure the unit is hazardous.

- 4 For table and shelf installations, attach the stick-on feet. The Altitude 300-2™ kit comes with four stick-on feet for use when the unit is installed on top of a table or shelf. The feet do not have to be used for wall and ceiling installations.



The stick-on feet have not been tested for use in a plenum space. Do not use them for above the ceiling installations.

- 5 Connect the Ethernet Cable - The Altitude 300-2™ is connected to a powered, 10/100BaseT Ethernet cable from a Summit 300-48™.



While the Altitude 300-2™ uses standard 10/100BaseT signals and PoE power, it should only be connected to a Summit 300-48™ port for the proper operation of the management and configuration features of Extreme Networks' Unified Access System.

- 6 Connect the computer cable lock (optional). When the Altitude 300-2™ installation does not use the universal mounting bracket, the unit can be locked with a computer cable. The Altitude 300-2™ has a standard computer cable lock hole located at the rear of the box, see Figure 1: Rear View Of Altitude 300-2i™ on page 10, or Figure 2: Rear View Of Altitude 300-2d™ on page 10.
- 7 Connect the external antennas, Altitude 300-2d™. For the Altitude 300-2i™ skip to step 8. The Altitude 300-2d™ has connectors for external antennas, see Figure 2: Rear View Of Altitude 300-2d™ on page 10. The access unit should be located within the reach of the antenna's cables. The large RP-TNC connectors are used for 2.4 GHz 802.11b/g antennas and the small RP-SMA connectors for 5 GHz 802.11a antennas. Two connectors of each type are supplied to support spatial diversity. When this step is completed go to step 10.
- 8 Attach the antenna shrouds (Altitude 300-2i™) - If the plastic cover is going to be used attach the antenna shrouds to the antennas, see Figure 8: Antenna Shroud on page 22.
- 9 Adjust the Integrated antennas, Altitude 300-2i™ - The Altitude 300-2i™ is equipped with two integrated dual band antennas that connect to both the 802.11a and 802.11b/g radios. Selecting the proper angle for the antennas is

important to achieve the best performance from the system. For this reason the Altitude 300-2i™ is equipped with antennas that can be rotated. Once the proper angle has been set the Altitude 300-2i™ is outfitted with antenna shrouds that work with the plastic cover to lock in the proper angle. This prevents the antennas from being accidentally misaligned after installation.

- 10 Attach the plastic cover -Attach the optional plastic cover to the box, see Figure 10: Plastic Cover Installation on page 23. After the cover has been secured push on each antenna to make sure its shroud is locked in position. This ensures that the teeth on the shroud are engaged with the teeth on the cover.

Altitude 300-2™ and Mounting Hardware

Before starting to install the wireless port and its hardware, take time to become familiar with the parts and their physical features.

Universal Mounting Bracket

The universal mounting bracket included with the wireless port is designed to mount on vertical and horizontal surfaces like walls and ceilings. It can be attached to electrical junction boxes in place of a wall plate and the Ethernet cable routed from the wall or ceiling through the central hole in the bracket to the Altitude 300-2™'s Ethernet jack. The universal mounting bracket can also be directly attached to a solid surface and the Ethernet cable routed through the network cable hole in the rear of the plastic cover. The universal mounting bracket is also used for installations where the Altitude 300-2™ is placed in the plenum area above a hanging ceiling. For these locations it is designed to connect to a box hanger bar that is attached to the ceiling's T-Bars.

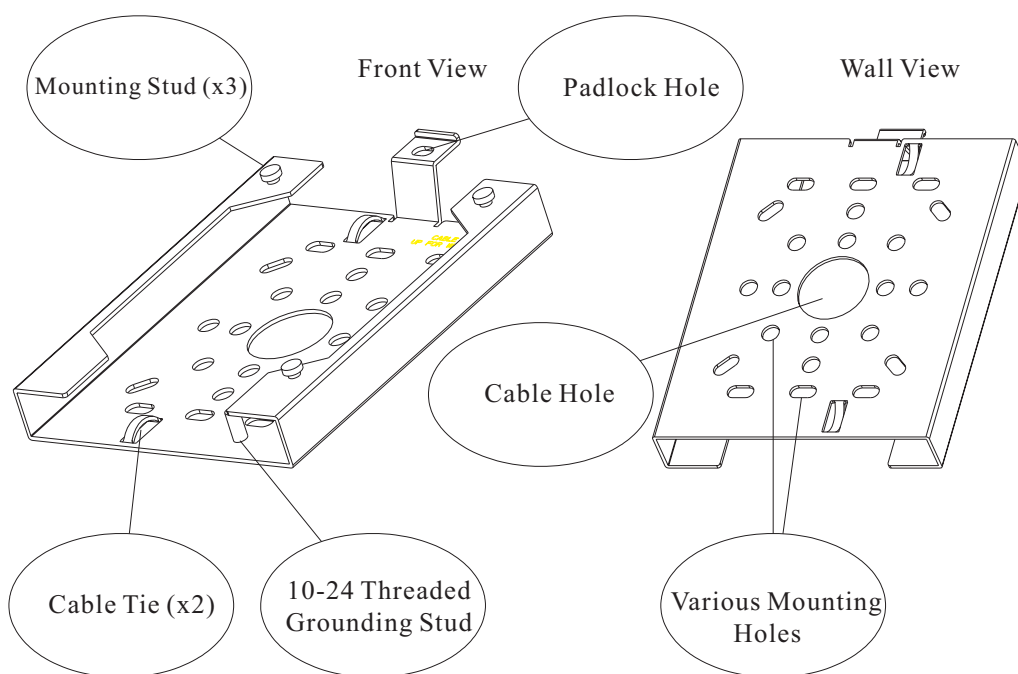

Figure 4: Universal Mounting Bracket

There are a number of holes and other features on the universal mounting bracket. The large central hole is for passing cables through when connecting the wireless port to in-the-wall cables. The smaller holes are designed to mate with various fastening hardware like junction boxes and box hanger bars. Two cable tie loops are provided for dressing cables. They accept standard nylon cable ties. The threaded stud is provided for grounding the plate when electrical codes require it. The lock hasp lines up with the lock hasp on the Altitude 300-2™. It secures the wireless port to the bracket. Either a lock or a cable tie can be placed in the lock holes.

To mount the Altitude 300-2™ on the bracket, place the box's mounting holes over the mounting studs on the bracket. Firmly slide the wireless port along the mounting studs until the holes in the lock hasps line up. The unit is designed to snap into place so some force is required.

▲▲ WARNING!

Make sure the holes in the lock hasps are lined up to ensure that the wireless port is completely seated. Also make sure that the wireless port is engaged on all three mounting studs.

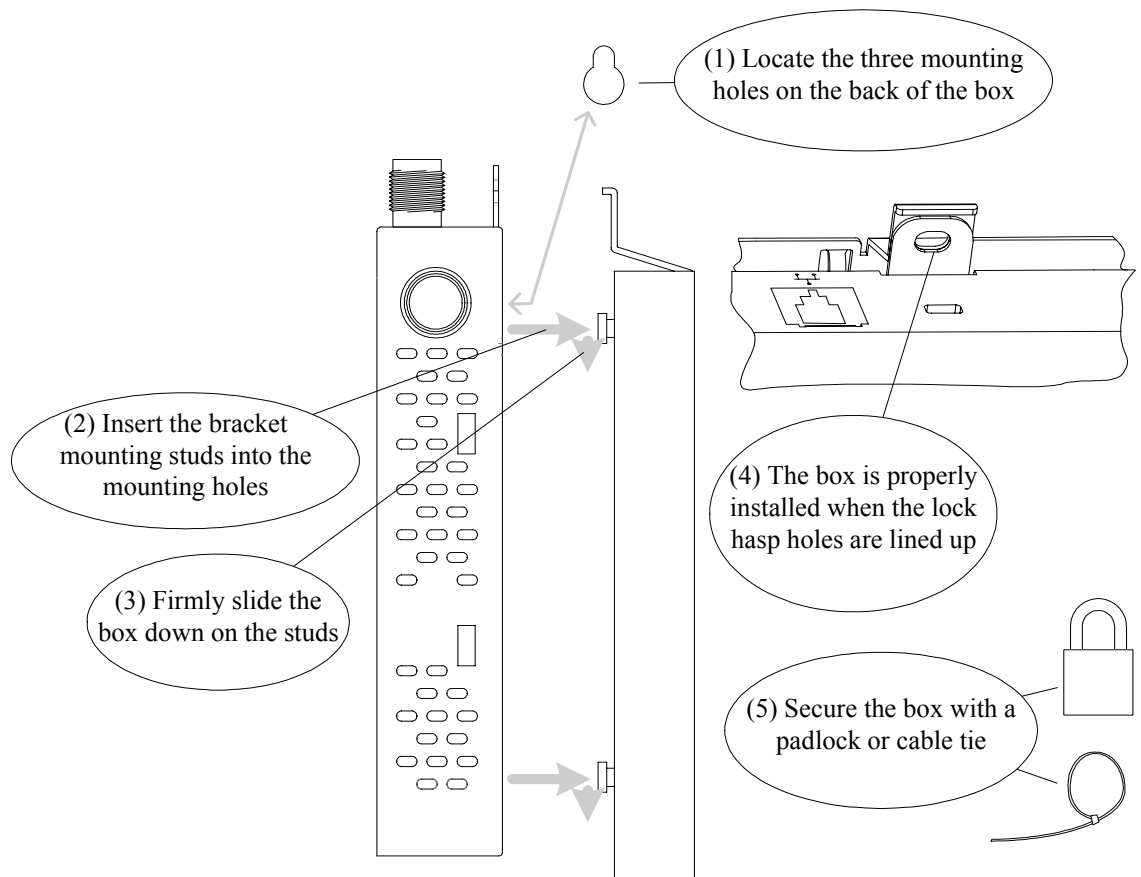

Figure 5: Mounting The Wireless Port On The Universal Mounting Bracket

To remove the wireless port from the universal mounting bracket first remove the lock or cable tie. Push the box in the direction of the lock hasp while gently lifting it away from the bracket.

The universal mounting bracket is part of the Altitude 300-2™ kit. Spares may also be ordered. The part number is 15921.

T-Bar Fasteners and Spacers

The T-Bar fasteners included with the wireless port are designed to connect to a range of hanging ceiling T-Bar sizes. Following the steps in Figure 6, spread the T-Bar fastener apart, place it on the T-Bar and squeeze it together until it is firmly seated on the T-Bar. With the two T-Bar fasteners in place and properly spaced to match the brackets T-Bar fastener holes, determine if spacers are needed. The T-Bar fastener spacers are designed for hanging ceilings where the ceiling tiles' bottom surface is below the T-Bar. If this is the case, install the spacer as show in the diagram. The spacer allows the universal mounting bracket to sit below the bottom surface of the ceiling tile.

The universal mounting bracket is installed using the large wing nuts provided. Make sure these wing nuts are tight.



WARNING!

For safety it is recommended that two T-Bar fasteners be used to connect the Altitude 300-2™ to a hanging ceiling. Make sure that the fasteners are securely on the T-Bar before installing the universal bracket and wireless port.

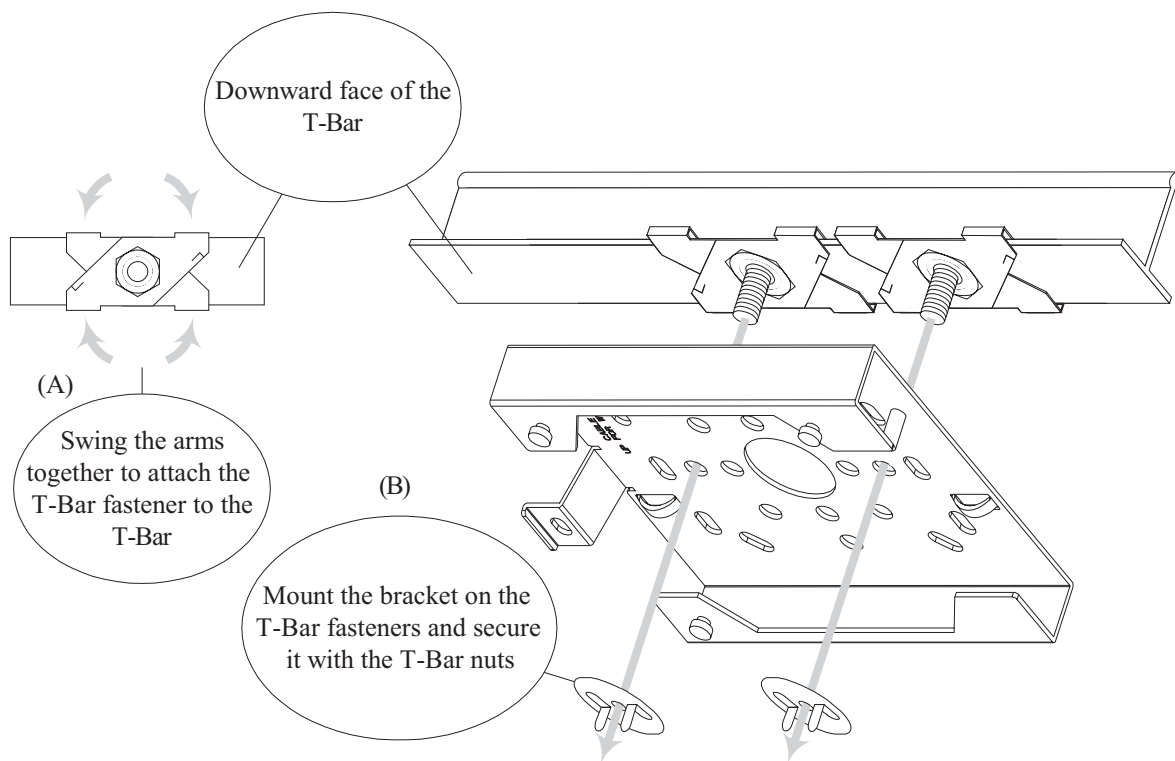

Figure 6: Installation On A Hanging Ceiling

The universal mounting bracket has mounting holes that allow it to be installed inline with the T-Bar as shown in Figure 6 or at right angles to the T-Bar.

Some hanging ceilings have tiles with bottom surfaces that hang below the bottom of the T-Bar. For these ceilings spacers are provided. The spacers go between the T-Bar fasteners and the universal mounting bracket as shown in Figure 7.

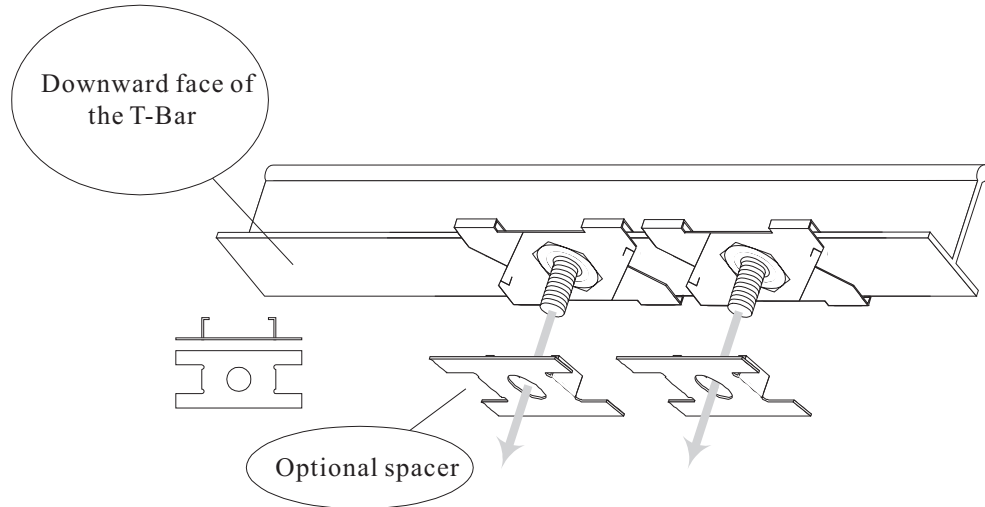

Figure 7: Installation Of Optional Spacer

 **NOTE**

Use a small piece of tape to hold the spacer in place on the universal mounting bracket and install the spacer and the bracket together.

Optional Antenna Shrouds

Antenna shrouds are used with the Altitude 300-2i™ that has integrated dual band antennas. They are an optional item that is ordered with one of the plastic cover kits. Before the plastic cover is snapped on, each antenna shroud is slipped over the antenna housing so that the gear teeth are next to the box. The shroud is slipped all the way down on the antenna housing until it is firmly seated on the antenna tube that comes out of the box. The shroud clips on to the tube. With the shroud installed, the antenna is still free to be rotated to the desired angle. The process is repeated for the other side of the box.

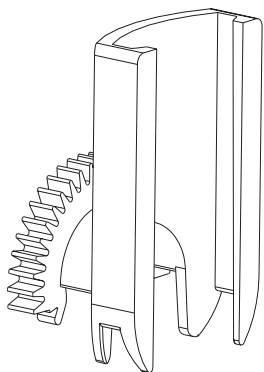

Figure 8: Antenna Shroud

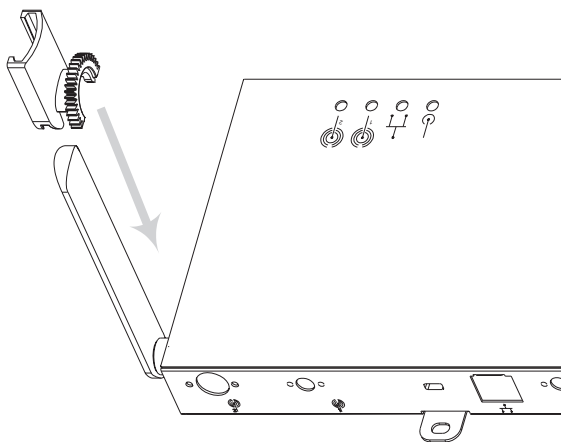

Figure 9: Antenna Shroud Installation

Optional Plastic Cover

The plastic cover is used with either the Altitude 300-2i™ or Altitude 300-2d™. Plastic covers are optional and are ordered with the plastic cover kit. The cover is installed on the Altitude 300-2™ after all cable connections and antenna adjustments are made and after the unit is locked or secured. To install the plastic cover place it directly over the box and line up the antenna slots in the cover with the antenna tubes on the box. While gently pulling out on the sides of the case where the clips are, press the cover firmly on to the box. The installer should hear and feel the cover snap into position.

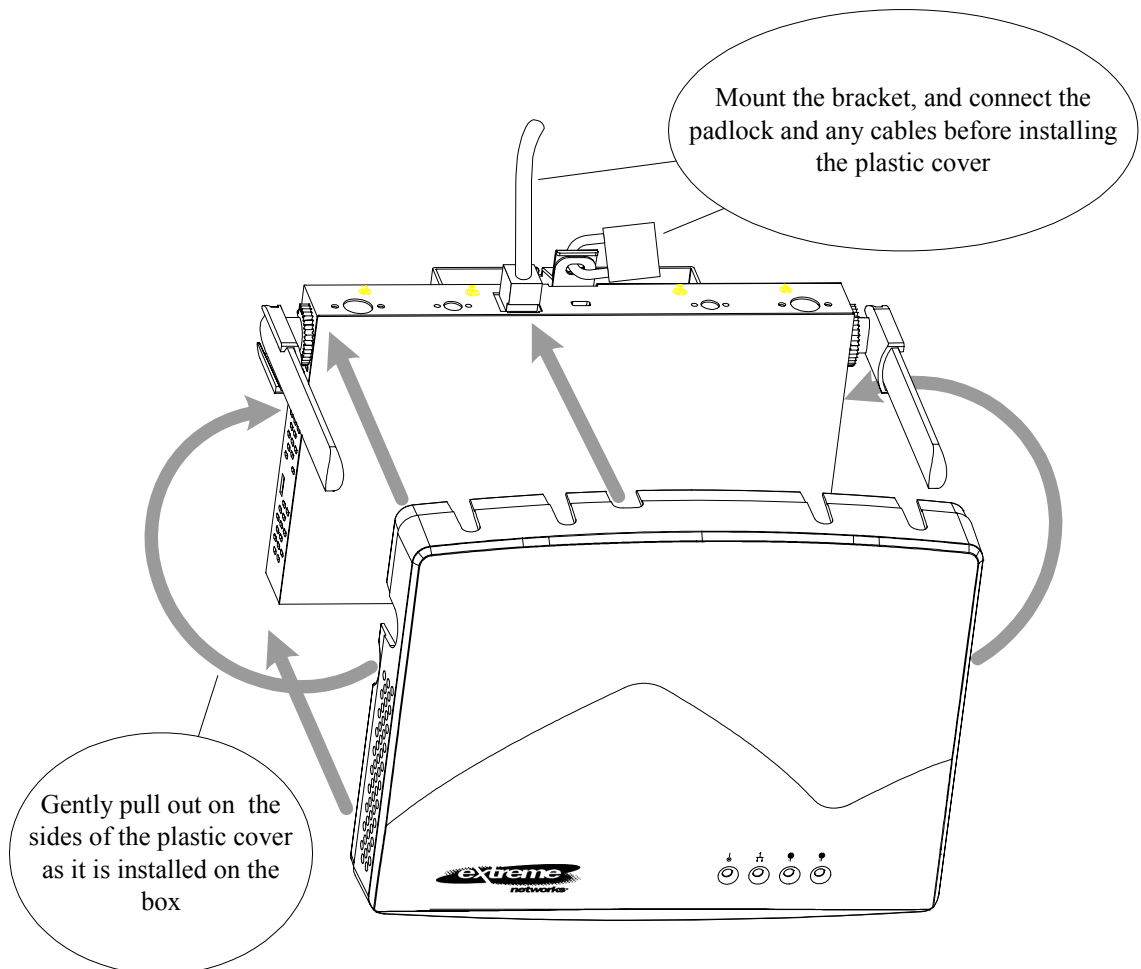

Figure 10: Plastic Cover Installation



The cover is designed to secure the Altitude 300-2™ from casual tampering that can affect service to the clients. With the case in place the unit can't be unlocked, the Ethernet connection can't be unplugged, the integrated antennas

(Altitude 300-2i™) can't be rotated and the external antenna connections (Altitude 300-2d™) can't be undone.

To remove the plastic cover, gently pull the sides near the clips outwards while pulling the cover off the box.

Painting The Plastic Cover.

The plastic cover can be painted to match a decor with any paint that is suitable for polycarbonate plastic. The plastic light pipe must be removed before painting. The light pipe assembly can be gently popped off using a screwdriver that is slipped into the small lips provided on the light pipe. After painting, reinstall the light pipe by snapping it back in place.



Painting the antennas is not recommended.

Ordering The Plastic Cover Kit.

The plastic cover kit may be ordered from Extreme Networks. The kit includes covers and antenna shrouds. Please consult the Extreme Networks product web site, www.extremenetworks.com, for the latest product information. The plastic cover kits offered include:

Product Number: 15922- five translucent covers and ten black antenna shrouds

Product Number: 15923- five cool gray covers and ten black antenna shrouds

Product Number: 15924- five cream covers and ten black antenna shrouds

External Antennas

The Altitude 300-2d™ uses external antennas. Consult the Extreme Networks product web page for a current list of available external antennas. External antennas are connected to the RP-TNC connectors for the 802.11b/g radio and to the RP-SMA connectors for the 802.11a radio. The external antennas are connected before the optional plastic cover is installed.



The Altitude 300-2d™ is designed for diversity with two antenna connectors for each radio. It is important for the proper operation of the wireless port that antennas be installed on each connector.

Placement of the Wireless Port

Choose a proper place for the wireless port. In general, the best location is at the center of the wireless coverage area, within line of sight of as many as possible wireless devices. Try to place the wireless port in a position that can best cover its cell. Normally, the higher the wireless port is placed, the better the overall performance.

Mounting Locations

The Altitude 300-2™ and its mounting hardware are designed for installation in a variety of places inside a building. The installation site may be selected for any combination of RF performance, aesthetics, and convenience reasons.



The Altitude 300-2™ is not designed for outdoor use or sites that exceed its environmental specifications.

Mounting Below A Hard Ceiling

The Altitude 300-2™ may be installed underneath a hard ceiling where wall anchors are used to mount the bracket. Select the orientation for the bracket remembering that that integrated antennas are on the side and to the back of the Altitude 300-2i™. Use the bracket as a template to mark the holes on the ceiling. For each of the four plastic anchors supplied with the unit, drill 4.8 mm (3/16") pilot holes, 24.5 mm (1") deep. If wall anchors are not being used drill 3.2 mm (1/8") holes, 1 inch (25.4 mm) deep. Install the bracket using the screws from the kit. The Altitude 300-2™ is designed to slip into the mounting slots on the bracket and slide all the way to the front, see Figure 5: Mounting The Wireless Port On The Universal Mounting Bracket on page 19. The unit should then be secured with either a padlock (not supplied) or a cable tie (supplied).

The installer may now follow the standard instructions for connecting the Ethernet cable, antenna shrouds for integrated antennas, and the plastic cover.



The Altitude 300-2™ is not secured to the bracket unless a padlock is used. If a padlock is not used the unit should be secured to the bracket by a cable tie through the lock hasp to keep it from falling. Failure to secure the unit is hazardous.

Mounting Below A Hanging Ceiling

The Altitude 300-2™ may be suspended from the T-Bars of a hanging ceiling. The mounting kit contains two T-Bar fasteners that can be adjusted for a variety of T-Bar widths. There are a number of round holes on the bracket that can be used for the T-Bar fasteners; use two that are convenient for the required orientation on the ceiling. The bracket is oriented on the T-Bar with so that the antennas face the desired direction. Use the bracket to lightly mark where the T-Bar fasteners should be placed. Install the two T-Bar fasteners on the T-Bar, see Figure 6: Installation On A Hanging Ceiling on page 20. Some ceilings have ceiling tiles that hang down below the bottom of the T-Bar. Spacers are provided with the kit for these types of tiles. The spacers go between the T-Bar fasteners and the bracket with the spacer's face against the bracket, see Figure 7: Installation Of Optional Spacer on page 21. Mount the bracket and make sure fasteners are tight and the bracket is secure. The Altitude 300-2™ is now slipped into the bracket's mounting slots and slid all the way to the back, see Figure 5: Mounting The Wireless Port On The Universal Mounting Bracket on page 19. The unit should then be secured with either a padlock (not supplied) or a cable tie (supplied). The installer may now follow the standard instructions for connecting the Ethernet cable, antenna shrouds for integrated antennas, and the plastic cover.



The Altitude 300-2™ is not secured to the bracket unless a padlock is used. If a padlock is not used the unit should be secured to the bracket by a cable tie through the lock hasp to keep it from falling. Failure to secure the unit is hazardous.

Mounting Above The Hanging Ceiling

The Altitude 300-2d™ is compliant with UL 2043 for installation in the plenum area above a hanging ceiling. The installer needs to make sure that the Ethernet cable used to connect to the unit is also plenum rated, see the National Electric Code, NEC, Section 300-22(C). Equipment above the hanging ceiling should be secured to the T-Bars using a box hanger (not supplied). The universal mounting bracket has been designed to work with box hangers such as those from B-Line or Caddy, see Figure 11: Above The Ceiling Box Hanger Mount on page 28.

Examples of these T-Bar box hangers products are:

B-Line model: BA50A, www.cooperblineline.com

Caddy model: 512-BU, www.ericco.com

External antennas are recommended for installations above the ceiling. Locate where the external antenna will be located and their orientation. Select a site above the ceiling for the Altitude 300-2d™. This should be within reach of the external antenna's cables. Install the box hanger following the manufacturer's instructions. If the box hanger comes with a box the universal bracket can be installed onto the box or the box can be taken off and the bracket can be installed directly onto the box hanger bar using the fastener provided by the manufacturer. Make sure all the fasteners are tight before mounting the Altitude 300-2™ on the bracket. The Altitude 300-2™ should be secured to the bracket using either a padlock or a cable tie.



WARNING!

The Altitude 300-2™ is not secured to the bracket unless a padlock is used. If a padlock is not used the unit should be secured to the bracket by a cable tie through the lock hasp to keep it from falling. Failure to secure the unit is hazardous.

Connect the external antenna cables and the powered Ethernet cable to the Altitude 300-2d™.

**WARNING!**

The plastic cover and the antenna shrouds have not been tested for use in a plenum space. Do not use them for above the ceiling installations.

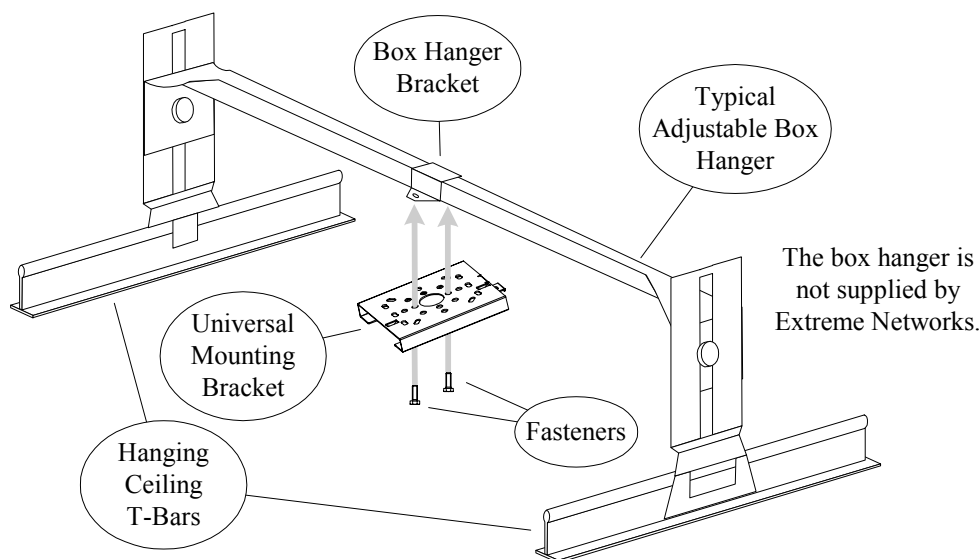

Figure 11: Above The Ceiling Box Hanger Mount

Mounting On A Wall

The Altitude 300-2™ can be mounted on a vertical surface using the universal mounting bracket supplied. The vertical position should be with the Ethernet cable and lock hasp pointing up. Select the location for the unit and use the bracket as a template to mark the holes in the ceiling. For each of the four plastic anchors supplied with the unit, drill 4.8 mm (3/16") pilot holes, 24.5 mm (1") deep. If wall anchors are not being used drill 3.2 mm (1/8") holes, 1 inch (25.4 mm) deep. Install the bracket using the screws from the kit. The Altitude 300-2™ is designed to slip into the mounting slots on the bracket and slide all the way down, see Figure 5: Mounting The Wireless Port On The Universal Mounting Bracket on page 19. The unit should then be secured with either a padlock or a cable tie. The installer may now follow the standard instructions for connecting the Ethernet cable, antenna shrouds for integrated antennas, and the plastic cover.



WARNING!

The Altitude 300-2™ is not secured to the bracket unless a padlock is used. If a padlock is not used the unit should be secured to the bracket by a cable tie through the lock hasp to keep it from falling. Failure to secure the unit is hazardous.

Mounting On A Table Or Shelf

The Altitude 300-2™ can be installed on a table or shelf using the stick-on feet supplied in the unit's kit. After the feet are applied, the unit is placed on the horizontal surface and the powered Ethernet cable attached. If the unit is to be locked a standard computer cable and lock can be used. The computer lock hole is located at the rear of the Altitude 300-2™, see Figure 1: Rear View Of Altitude 300-2i™ on page 10. The antennas are installed and the antennas are adjusted now for optimal performance. After that the plastic cover is attached, securing the antennas and Ethernet cable.

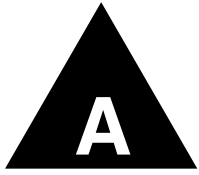

Specifications

General Specifications

Maximum Number Of Tunable Channels

802.11a

FCC/IC: 13

ETSI: up to 19, varies by countries

France: 8

Spain: 19

MMK: 4

802.11b/g

FCC/IC: 1-11

ETSI: 1-13

France: 1-13

Spain: 1-13

MKK: 1-13 (802.11g), 1-14 (802.11b)

Data Rate

802.11a: 6, 9, 12, 18, 24, 36, 48, 54 Mbps per channel

802.11b: 1, 2, 5.5, 11 Mbps per channel

802.11g: 1, 2, 5.5, 11, 6, 9, 12, 18, 24, 36, 48, 54 Mbps per channel

Operating Frequency

802.11a

5.15 ~ 5.25 GHz (lower UNII band): US/Canada, Europe, Japan

5.25 ~ 5.25 GHz (middle UNII band): US/Canada, Europe

5.47 ~ 5.725 GHz: Europe

5.725 ~ 5.850 GHz (upper UNII/ISM): US/Canada

802.11b/g

2.4 ~ 2.4835 GHz

Maximum Output Power

(Note that the maximum allowable setting varies with individual country regulations and the antennas used)

802.11a

5.15 ~ to 5.25 GHz: 16 dBm

5.25 ~ to 5.35 GHz: 19 dBm

5.725 ~ to 5.85 GHz: 20 dBm

802.11b

18 dBm

802.11g

18 dBm

Radio Configurations

Dual band: 2.4 GHz ISM and 5 GHz

Dual channel: one 802.11a and one 802.11b/g

Number of Clients

Greater than 256

Network Configuration

Infrastructure

Power supply

Power Over Ethernet (PoE) Standard: IEEE 802.3af

11 watts when both channels are operating

Physical Size With Plastic Cover

21.3 (wide) x 16 (deep)x 4 (high) cm, (8.4 x 6.3 x 1.6 in)

Mounting bracket adds 2 cm (0.8 in) to the height

Weight

635 grams (22.4 oz)

Add 20 grams (0.71 oz) for the mounting bracket

LED Indicators

Ready (Power On/Fault), LAN (Ethernet Link/Activity), radio1 -802.11a and radio2 -802.11b/g

(Wireless On/Activity)

Network Management

EPICenterO

Location

Indoor only

Temperature

Operating: 0 to 55 oC (32 to 131 oF)

Storage: -10 to 70 oC (-14 to 158 oF)

Humidity

10% to 95% (non-condensing)

Operational Shock

30 m/s² (3g)

Operational & Transportation Standards

EN/ETSI 300 019-2-1 v2.1.2 - Class 1.2 Storage

EN/ETSI 300 019-2-2 v2.1.2 - Class 2.3 Transportation

EN/ETSI 300 019-2-3 v2.1.2 - Class 3.1e Operational

Specifications

EN/ETSI 300 753 (1997-10) - Acoustic Noise

ASTM D5276 Drop Packaged

ASTM D3580 Random Vibration Packaged 1.5G

Standards

IEEE 802.3 10BASE-T, IEEE 802.3u 100BASE-TX

IEEE 802.11a/b/g

IEEE 802.3af

Wi-Fi member

Sensitivity

Table 3: 802.11a Radio

Modulation/Rates	Sensitivity (dBm)
BPSK (6 Mbps)	-91
BPSK (9 Mbps)	-89
QPSK (12 Mbps)	-88
QPSK (18 Mbps)	-86
16 QAM (24 Mbps)	-83
16 QAM (36 Mbps)	-79
64 QAM (48 Mbps)	-75
64QAM(54 Mbps)	-70

Table 4: 802.11b/g Radio

Modulation/Rates		Sensitivity (dBm)
DSSS-DBPSK (1Mbps)	b	-91
DSSS-DQPSK (2 Mbps)	b	-88
CCK-DBPSK (5.5 Mbps)	b	-87
CCK_DQPSK (11 Mbps)	b	-85
BPSK (6 Mbps)	g	-89
BPSK (9 Mbps)	g	-88
QPSK (12 Mbps)	g	-87
QPSK (18 Mbps)	g	-85
16 QAM (24 Mbps)	g	-82
16 QAM (36 Mbps)	g	-79
64 QAM (48 Mbps)	g	-74
64QAM(54 Mbps)	g	-71

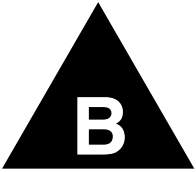

Maximum Distance Table

Important Notice

Maximum distances posted below are actual tested distance thresholds for the Altitude 300-2i™ with integrated antenna. However, there are many variables such as barrier composition and construction and local environmental interference that may impact your actual distances and cause you to experience distance thresholds far lower than those posted below.

Table 5: 802.11a Maximum Distances

802.11a Wireless Products Maximum Distance Table, Integrated Antenna Speed and Distance Ranges			
EnvironmentalCondition	54 Mbps	18 Mbps	6 Mbps
OutdoorEnvironment¹	31 m (100 ft)	168 m (550 ft)	335 m (1100 ft)
IndoorEnvironment²	18 m (60 ft)	46 m (150 ft)	64 m (210 ft)

- 1. Outdoor Environment: A line-of-sight environment with no interference or obstruction between the wireless port and clients.
- 2. Indoor Environment: A typical office or home environment with floor to ceiling obstructions between the wireless port and clients.

Table 6: 802.11b Maximum Distances

802.11b Wireless Products Maximum Distance Table, Integrated Antenna Speed and Distance Ranges				
EnvironmentalCondition	11 Mbps	5.5 Mbps	2 Mbps	1 Mbps
OutdoorEnvironment¹	137 m (450 ft)	238 m (780 ft)	305 m (1000 ft)	488 m (1600 ft)
IndoorEnvironment²	49 m (160 ft)	238 m (780 ft)	103 m (340 ft)	152 m (500 ft)

- 1. Outdoor Environment: A line-of-sight environment with no interference or obstruction between the wireless port and clients.

2. Indoor Environment: A typical office or home environment with floor to ceiling obstructions between the wireless port and clients.

Table 7: 802.11g Maximum Distances

**802.11g Wireless Products Maximum Distance Table,
Integrated Antenna Speed and Distance Ranges**

EnvironmentalCondition	54 Mbps	18 Mbps	6 Mbps
OutdoorEnvironment¹	34 m (110 ft)	104 m (340 ft)	198 m (650 ft)
IndoorEnvironment²	20m (65ft)	46 m (150 ft)	61 m (200 ft)

1. Outdoor Environment: A line-of-sight environment with no interference or obstruction between the wireless port and clients.
2. Indoor Environment: A typical office or home environment with floor to ceiling obstructions between the wireless port and clients.

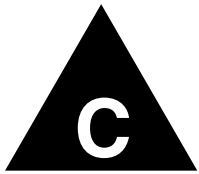

Integrated Dual Band Antenna Pattern

The Altitude 300-2i™ has two integrated dual band antennas. The characteristics of the antennas are given in the tables and figures below.

Table 8: Integrated Antenna Electrical Specification

Frequency range	2.4 GHz - 2.5 GHz	5.12 GHz 1 5.875 GHz
Gain ¹	1.5 dBi	4.5 dBi
Polarization	Linear, vertical	Linear, vertical

1. Exclusive of internal cable loss: for 5 GHz band, 0.8 dB; for 2.4 GHz band, 0.5 dB.

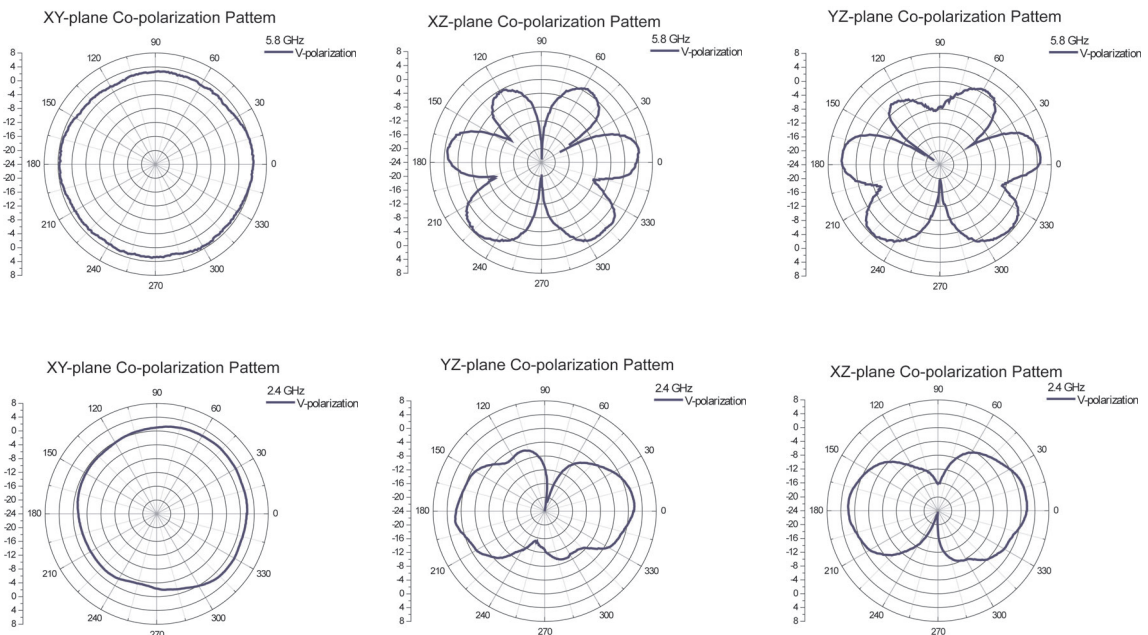

Figure 12: Antenna Radiation Patterns

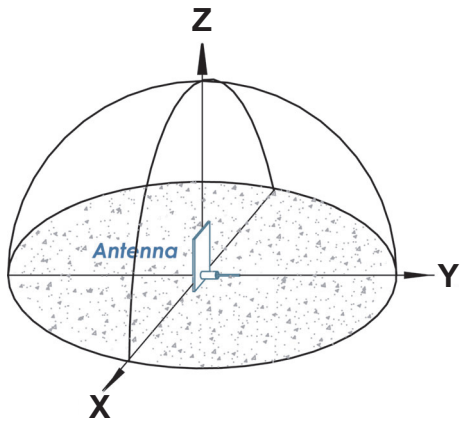

Figure 13: Antenna Radiation Pattern Reference Diagram

Regulatory Compliances

Overview

The Altitude 300-2™ wireless port is manufactured by Extreme Networks in several regulatory domain configurations. Each regulatory domain includes various countries that share similar regulatory requirements. Each regulatory domain is listed in the table below with corresponding countries. It is the end users responsible to obtain an Altitude 300-2™ with the proper regulatory domain for use in the intended country of operation.

The end user is also responsible to install the latest version of software made available by Extreme Networks in order to insure compliance with country requirements and restrictions for each system installation. Since countries are constantly opening up new frequencies and changing output power limits it is advantageous to maintain the latest software version to take advantage of these improvements. Please consult the software manual of the PoE WLAN switch connected to your Altitude 300-2™ for detailed instructions for installing and upgrading software.

NOTE

The Altitude 300-2™ is completely configured and managed by the PoE WLAN switch connected to the Altitude 300-2™. Please consult the software manual of the PoE WLAN switch to properly configure the Altitude 300-2™.

NOTE

Not all regulatory domains have been approved. For countries not listed within the table below please contact your Extreme Networks representative for the proper regulatory domain Altitude 300-2™ wireless port.

Table 9: Regulator Domain Product Listing

Model Number	Product	Regulatory Domain
15700	Altitude 300-2i	North America
15701	Altitude 300-2d	North America
15702	Altitude 300-2i	Japan
15703	Altitude 300-2d	Japan
15704	Altitude 300-2i	Taiwan
15705	Altitude 300-2d	Taiwan
15706	Altitude 300-2i	European Community, Australia, Korea, Mexico & China. Other countries may need additional certifications / approvals before offered for use in those countries. *
15707	Altitude 300-2d	European Community, Australia, Korea, Mexico & China. Other countries may need additional certifications / approvals before offered in those countries. *

* Operation in other countries may be dependant on securing proper certifications / regulatory approvals. For more details on country specific ordering please consult your Extreme Networks representative.

General Compliance Design Guidelines

Various countries have regulatory requirement that do not allow the end user to select the country of operation or operating channels for the wireless access point. To satisfy these requirements, the Altitude 300-2TM wireless port is pre-programmed with a permanent country code that identifies the AP to the PoE WLAN switch as a country that prohibits the end user to select the country they are in. Since these AP's are only sold in these specific countries, the PoE WLAN switch is able to automatically configure AP to operate at the proper operating frequencies, channels and power outputs without end user interaction.

When an Altitude 300-2TM wireless port is connected that does not have a pre-programmed country code, such as with the "EU & Rest of World" Altitude 300-2TM, the PoE WLAN switch will prompt user to enter the correct country code for system operation. The user must then enter the country code on the PoE WLAN switch before ports will be enabled and the desired frequencies, channels and power outputs be set. This allows a single AP to be used for

several countries where the end user is allowed to select the country of operation.

After the first Altitude 300-2™ wireless port is connected to the PoE WLAN switch it inherits the country code of the first wireless port. Each wireless port connected thereafter must have the same country code as the first wireless port connected for it to be operational. If there is a mismatch between the country codes between the Altitude 300-2™ wireless port and the code programmed on the PoE WLAN switch, then the Altitude 300-2™ wireless port is not allowed to come up.

The Altitude 300-2™ wireless port has a built-in regulatory compliance security system. If a country code is entered into the “EU & Rest of World” Altitude 300-2™ wireless port that does not have the proper regulatory certifications the PoE WLAN switch will not configure the Altitude 300-2™ wireless port for operation. An updated version of the PoE WLAN software must be uploaded before operation in the country is possible. Software is not released until all country specific certifications are obtained. This insures that end users will not be able to configure the Altitude 300-2™ system for a country that it is not intended to operate within.

 **NOTE**

The end user is responsible to enter the proper country code for the country of intended use. Extreme Networks is not liable for improper country code configuration.

 **NOTE**

Extreme Networks has not certified the Altitude 300-2™ with any third party antennas. To assure compliance, use the Extreme Networks' certified antenna or an antenna that is certified by a professional wireless network installer to be compliant when used with the Altitude 300-2d™ wireless port.

North America, Japan, Taiwan and others have dedicated Access points identified by their specific regulatory domain (See chart above). These Altitude 300-2O wireless ports will not require a country code to be entered before operation. These units will automatically configure themselves upon connection to the PoE WLAN switch after inserting the RJ-45 Power over Ethernet (PoE) cable.

The PoE WLAN switch will automatically limit the allowable channels determined by the current country code entered. Incorrectly entering the country of operation may result in illegal operation and may cause harmful interference to other system. The user is obligated to ensure the device is operating according to the channel limitations, indoor/outdoor restrictions and license requirements for each European Community country as described in this document.

North America

The Altitude 300-2™ Model 15700 & 15701 is designed for use in the United States, Canada and other countries that accept the related regulatory requirements and limitations. For more details on the application of the Altitude 300-2™ Model 15700 & 15701 to additional countries please consult your Extreme Networks representative.

The North American regulatory domain Attitude 300-2™ wireless port is a dedicated wireless ports with fixed frequency bands, channel allocations & power output settings. This wireless port will not require a country code to be entered before operation. These units will automatically configure themselves upon connection to the Poe WLAN switch after inserting the RJ-45 Power over Ethernet (PoE) cable.

Please consult the appropriate PoE WLAN switch Software Guide for proper software configuration.

United States - FCC Declaration of Conformity Statement

This device complies with Part 15 of the FCC Rules. Operation is subject to the following two conditions:

- (1) This device may not cause harmful interference, and
- (2) this device must accept any interference received, including interference that may cause undesired operation.

This equipment meets the following conformance standards:

Table 10: FCC Conformance Standards

Safety	<ul style="list-style-type: none">• UL 60950 3rd Edition, Listed Accessory	<ul style="list-style-type: none">• UL 2043 Plenum rated (w/o plastic cover)
EMC	<ul style="list-style-type: none">• FCC CFR 47 Part 15 Class B	
Radio Transceiver	<ul style="list-style-type: none">• CFR 47 Part 15.247, Class C, 2.4GHz• CFR 47 Part 15.407, Class C, 5.0GHz• CFR 47 Part 15.205, 15.207, 15.209• CFR 47 Part 2.1091, 2.1093	Other: <ul style="list-style-type: none">• IEEE 802.11a (5.0GHz)• IEEE 802.11b/g (2.4GHz)
Environmental	<ul style="list-style-type: none">• ASTM D5276 Drop Packagedo ASTM D3580 Random Vibration Packaged 1.5G	

FCC ID# : RJF-ALT300-2-NA



The altitude 300-2i™ is restricted for indoor use in the UNII 5.15 - 5.25GHz band in accordance with 47 CFR 15.407(e).

This equipment has been tested and found to comply with the limits for a Class B digital device, pursuant to Part 15 of the FCC Rules. These limits are designed to provide reasonable protection against harmful interference when the equipment is operated in a residential and business environment. This equipment generates, uses and radiates radio frequency energy, and if not installed and used in accordance with instructions, may cause harmful interference. However, there is no guarantee that interference will not occur. If this equipment does cause harmful interference, which can be determined by turning the equipment off and on, the user is encouraged to try to correct the interference by one or more of the following measures:

- Reorient or relocate the transceiver antenna
- Increase the separation between the equipment and transceiver.
- Consult the dealer or an experienced radio/TV technician



The Part 15 radio device operates on a non-interference basis with other devices operating at this frequency when using integrated antennas or other Extreme Networks certified antennas. Any changes or modification to the product not expressly approved by Extreme Networks could void the user's authority to operate this device.

**CAUTION****FCC RF Radiation Exposure Statement:**

This equipment complies with “Evaluating Compliance with FCC Guidelines for Human Exposure to Radio Frequency Electromagnetic Fields” (OET Bullet 65, Supplement C). This equipment should be installed and operated with a minimum distance of 20 centimeters (8 inches) between the radiator and your body or other co-located operating antennas.

Department of Communications Canada Compliance Statement

This digital apparatus does not exceed the Class B limits for radio noise emissions from digital apparatus as set out in the interference-causing equipment standard entitled “Digital Apparatus,” ICES-003 of the Department of Communications.

Cet appareil numérique respecte les limites de bruits radioélectriques applicables aux appareils numériques de Classe B prescrites dans la norme sur le matériel brouilleur: “Appareils Numériques,” NMB-003 édictée par le ministère des Communications.

This device complies with Part 15 of the FCC Rules and Canadian Standard RSS-210. Operation is subject to the following conditions: (1) This device may not cause harmful interference, and (2) this device must accept any interference received, including interference that may cause undesired operation. This Class B device digital apparatus complies with Canada ICES-003.”

This equipment meets the following conformance standards:

Table 11: Canada Conformance Standards

Safety	<ul style="list-style-type: none"> ULC listed Acc. to CSA22.2 #60950-00 	<ul style="list-style-type: none"> Plenum Rated Enclosure w/o plastic cover
EMC	<ul style="list-style-type: none"> ICES-003 Class B 	
Radio Transceiver	<ul style="list-style-type: none"> RSS-210 (802.11a) RSS-139-1 (802.11b/g) 	Other: <ul style="list-style-type: none"> IEEE 802.11a (5.0Ghz) IEEE 802.11b/g (2.4GHz)

European Community & Other Countries

Declaration of Conformity with regard to R&TTE Directive of the European Union 1999/5/EC

Marking by the symbol **CE** (0560) indicates compliance with the Essential Requirements of the R&TTE Directive of the European Union (1999/5/EC).

This equipment meets the following conformance standards:

Table 12: European Conformance Standards

Safety	<ul style="list-style-type: none"> • CB Scheme, IEC 60950:1999 with all available country deviations 	<ul style="list-style-type: none"> • GS Mark, EN 60950:2000 • Plenum Rated Enclosure (Without plastic cover)
EMC	<i>Emissions</i>	
	<ul style="list-style-type: none"> • EN55022:1998 Class B • CISPR22:1997 Class B 	<ul style="list-style-type: none"> • EN61000-3-2 and 3-3 • EN/ETSI 301 489-17 (9-2000)
	<i>Immunity</i>	
	<ul style="list-style-type: none"> • EN55024:1998 Class A, includes IEC 61000-4-2,3,4,5,6,11 • EN/ETSI 301 489-17 (9-2000) 	
Radio Transceiver	<ul style="list-style-type: none"> • R&TTE Directive 1999/5/EC • ETSI/EN 300 328-2 2003-04 (2.4GHz) • ETSI/EN 301 893-1 2002-07 (5.0GHz) • ETSI/EN 301 489-1 2002-08 • ETSI/EN 301 489-17 2002-08 	Other: <ul style="list-style-type: none"> • IEEE 802.11a (5.0Ghz) • IEEE 802.11b/g (2.4GHz)
Environmental	<ul style="list-style-type: none"> • EN/ETSI 300 019-2-1 v2.1.2 - Class 1.2 Storage • EN/ETSI 300 019-2-2 v2.1.2 - Class 2.3 Transportation • EN/ETSI 300 019-2-3 v2.1.2 - Class 3.1e Operational • ASTM D5276 Drop Packaged • ASTM D3580 Random Vibration Packaged 1.5G 	

Table 13: Declaration of Conformity in Languages of the European Community

English	Hereby, Extreme Networks, declares that this Radio LAN device is in compliance with the essential requirements and other relevant provisions of Directive 1999/5/EC.
Finnish	Valmistaja Extreme Networks vakuuttaa taten etta Radio LAN device tyyppinen laite on direktiivin 1999/5/EY oleellisten vaatimusten ja sita koskevien direktiivin muiden ehtojen mukainen.
Dutch	Hierbij verklaart Extreme Networks dat het toestel Radio LAN device in overeenstemming is met de essentiële eisen en de andere relevante bepalingen van richtlijn 1999/5/EG Bij deze verklaart Extreme Networks dat deze Radio LAN device voldoet aan de essentiële eisen en aan de overige relevante bepalingen van Richtlijn 1999/5/EC.
French	Par la presente Extreme Networks declare que l'appareil Radio LAN device est conforme aux exigences essentielles et aux autres dispositions pertinentes de la directive 1999/5/CE Par la presente, Extreme Networks declare que ce Radio LAN device est conforme aux exigences essentielles et aux autres dispositions de la directive 1999/5/CE qui lui sont applicables
Swedish	Härmed intygar Extreme Networks att denna Radio LAN device står i överensstämmelse med de väsentliga egenskapskrav och övriga relevanta bestämmelser som framgår av direktiv 1999/5/EG.
Danish	Undertegnede Extreme Networks erklærer herved, at følgende udstyr Radio LAN device overholder de væsentlige krav og øvrige relevante krav i direktiv 1999/5/EF
German	Hiermit erklart Extreme Networks, dass sich dieser Radio LAN device in Übereinstimmung mit den grundlegenden Anforderungen und den anderen relevanten Vorschriften der Richtlinie 1999/5/EG befindet". (BMW) Hiermit erklart Extreme Networks die Übereinstimmung des Gerates Radio LAN device mit den grundlegenden Anforderungen und den anderen relevanten Festlegungen der Richtlinie 1999/5/EG. (Wien)
Greek	<i>ΜΕ ΤΗΝ ΠΑΡΟΥΣΑ Extreme Networks ΔΗΛΩΝΕΙ ΟΤΙ Radio LAN device ΣΥΜΜΟΡΦΩΝΕΤΑΙ ΠΡΟΣ ΤΙΣ ΟΥΣΙΩΔΕΙΣ ΑΠΑΙΤΗΣΕΙΣ ΚΑΙ ΤΙΣ ΛΟΙΠΕΣ ΣΧΕΤΙΚΕΣ ΔΙΑΤΑΞΕΙΣ ΤΗΣ ΟΔΗΓΙΑΣ 1999/5/ΕΚ</i>
Italian	Con la presente Extreme Networks dichiara che questo Radio LAN device è conforme ai requisiti essenziali ed alle altre disposizioni pertinenti stabilite dalla direttiva 1999/5/CE.
Spanish	Por medio de la presente Extreme Networks declara que el Radio LAN device cumple con los requisitos esenciales y cualesquiera otras disposiciones aplicables o exigibles de la Directiva 1999/5/CE
Portuguese	Extreme Networks declara que este Radio LAN device esta conforme com os requisitos essenciais e outras disposicoes da Directiva 1999/5/CE.

**NOTE**

A signed copy of Declaration of Conformity (DoC) can be obtained by contacting your Extreme Networks Representative.

Conditions of Use in the European Community

The Altitude 300-2™ wireless port is intended to operate in all countries of the European Community. Requirements for indoor vs. outdoor operation, license requirements and allowed channels of operation for certain European countries are described below and in product release notes.



The user is responsible to insure that the current channel of operation is in conformance with European National spectrum usage laws as described below and within release notes. A configuration utility has been provided with the PoE WLAN switch to allow the end user to check configuration and make necessary configuration changes to ensure proper operation occurs. Consult Poe WLAN software manual for detailed instructions on use of this utility.

- The user must refer to the PoE WLAN switch software manual for proper configuration of PoE WLAN switch. The proper country code must be entered into the PoE WLAN switch to ensure conformance with European National spectrum usage laws that match the country in which the device is operating. This will ensure the Altitude 300-2™ wireless port operates using the channels and transmit power specified by the applicable radio regulatory authority. The PoE WLAN switch will then automatically configure all subsequent Altitude 300-2™ wireless ports upon connection to the PoE WLAN switch via the Ethernet cable.
 - The software within the PoE WLAN switch will automatically limit the allowable channels determined by the current country code entered. Incorrectly entering the country of operation, or selection the correct indoor or outdoor setting on the Altitude 300-2d™ detachable antenna, may result in illegal operation and may cause harmful interference to other system. The user is obligated to ensure the device is operating according to the channel limitations, indoor/outdoor restrictions and license requirements for each European Community country.
 - This device employs a **radar detection** feature required for European Community operation in the 5GHz band. This feature is automatically enabled when the country of operation is correctly configured for any European Community country. The presence of nearby radar operation may result in temporary interruption of operation of this device. The radar detection feature will automatically restart operation on a channel free of radar.

--The 5GHz radio's **AutoChannelSelect/SmartSelect** setting described in the PoE WLAN switch software manual must always remain enabled to ensure that automatic 5GHz channel selection complies with European requirements. The current setting for this feature is found in the 5GHz Radio Configuration Window as described in the PoE WLAN switch software manual.

- The Altitude 300-2i™ wireless port with integral antenna can be operated indoors in all countries of the European Community using the 2.4GHz & 5GHz frequency bands except where noted below and in release notes.
- The Altitude 300-2d™ wireless port with detachable antenna can be operated indoors and outdoors in all countries of the European Community using the 2.4GHz band except where noted below and in the release notes. Outdoor use of the Altitude 300-2d™ detachable antenna is not allowed using 5.15 - 5.35 GHz bands (channels 36 to 64). See release notes for restricted frequencies bands & channels by country.
- Extreme certified detachable antennas are ready to be mounted and operated indoors or outdoors throughout all countries of the European Community. The Altitude 300-2d™ base unit must be installed indoors and connected to the outdoor antenna mounted outdoors through an exterior wall using an Extreme certified cable. See installation notes for details.
- In **Italy** the end-user must apply for a license from the national spectrum authority to operate this device outdoors.
- In **Belgium** outdoor operation is only permitted using the 2.46 - 2.4835 GHz band: Channel 13.
- In **France** outdoor operation is only permitted using the 2.4 - 2.454 GHz band: Channels 1 - 7.
- In Greece operation in the 5GHz frequency band is **not** allowed.

Other Country Specific Compliance Standards, Approvals and Declarations

Table 14: Other Country Specific Compliance Standards, Approvals and Declarations

Safety	• AS/NZS 3260
EMC	• AS/NZS 3548 Class B
Radio Transceiver	• Australia Compliance is based on EN/ETSI standards listed in EU section.

Japan

The Japan regulatory domain Attitude 300-2™ model 15702 15703 is a dedicated Wireless port with fixed frequency bands, channel allocations & power output settings. This wireless port will not require a country code to be entered before operation. This unit will automatically configure itself upon connection to the PoE WLAN switch after inserting the RJ-45 Power over Ethernet (PoE) cable.

Please consult the appropriate PoE WLAN switch Software Guide for proper software configuration.

Table 15: Operation Using 5 GHz Channels in the Japan Community

Safety	• CB Scheme, IEC 60950:1999 with all available country deviations	• Plenum Rated Enclosure (w/o plastic cover)
EMC	• VCCI Class B	
Radio Transceiver	• ARIB STD-T71, 5.0GHz	• IEEE 802.11a (5.0Ghz)
MKK Approved	• ARIB STD-T66, 2.4GHz • ARIB STD-33, 2.4GHz	• IEEE 802.11b/g (2.4GHz)

See Product label for TELEC ID#.

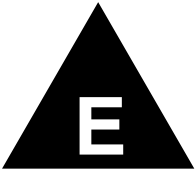

Power Over Ethernet Connector Pin Assignments

The Altitude 300-2™ complies with the IEEE P802.3af specification in its support of two modes of power delivery on the RJ-45 Ethernet jack. Table 7 shows the pins that are used to deliver -48 volts to the wireless port and Figure 14 shows the RJ-45 connector's pin number assignment. The Summit 300-48™ uses the MDI, Mode A to deliver power to the Altitude 300-2™.Maximum Number Of Tunable Channels

Table 16: Altitude 300-2™ Power Over Ethernet RJ-45 Pin Assignments

Conductor	Mode A: MDI (mode used by the Summit 300-48™)	Mode B: All
1	Negative Vport	
2	Negative Vport	
3	Positive Vport	
4		Positive Vport
5	Positive Vport	Positive Vport
6		
7		Negative Vport
8		Negative Vport

Vport = 44 to 57 volts under no load

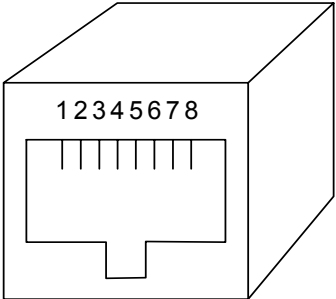

Figure 14: Ethernet Connector Pin Number Assignment

Terminology

Ad Hoc - An ad hoc wireless LAN is a group of computers, each with LAN adapters, connected as an independent wireless LAN.

Altitude 300-2™ - Extreme Networks' secure enterprise grade, scalable, and manageable wireless port. The Altitude 300-2™ supports two radio channels: one 802.11a channel and one 802.11b/g channel and it comes in two models: the Altitude 300-2i™ with integrated antennas and the Altitude 300-2d™ with connectors for detachable antennas.

Backbone - The core infrastructure of a network. The portion of the network that transports information from one central location to another central location where it is unloaded onto a local system.

Base Station - In mobile telecommunications, a base station is the central radio transmitter/receiver that maintains communications with the sets within its range. In cellular and personal communications applications, each cell or micro-cell has its own base station; each base station in turn is interconnected with other cells' bases.

BSS - BSS stands for "Basic Service Set." It is an wireless port and all the LAN PCs that are associated with it.

CSMA/CA - Carrier Sense Multiple Access with Collision Avoidance.

EPICenter™ - EPICenter™ management suite is a full-featured network management tool that simplifies configuration, troubleshooting, and status monitoring of IP-based networks. Offering a comprehensive set of network management applications including the ability to configure, monitor, troubleshoot, and manage the network and its elements, EPICentertm, delivers

on both the basic requirements of network management while adding valuable and intuitive features that help save time by streamlining common tasks.

ESS - ESS (ESS-ID, SSID) stands for “Extended Service Set.” More than one BSS is configured to become an Extended Service Set. LAN mobile users can roam between different BSSs in an ESS (ESS-ID, SSID).

Ethernet - A popular local area data communications network, which accepts transmission from computers and terminals.

Infrastructure - An integrated wireless and wired LAN is called an infrastructure configuration.

ISM - The Industrial Scientific and Medical band of regulated but unlicensed frequencies. The size and position of the band varies among different regulatory agencies. In the Americas the ISM S band is from 2.4 GHz to 2.4835 GHz and the ISM C band is from 5.725 GHz to 5.875 GHz which is also part of the UNII band.

Plenum (Hanging Ceiling) - The environmental air space above the ceiling tiles of a hanging ceiling. Equipment in the plenum must be tested for fire resistance and low-smoke-producing characteristics.

PoE - Power Over Ethernet. This is an IEEE standard 802.3af that specifies how power is delivered over Ethernet twisted pair cables.

RADIUS - Remote Authentication Dial-In User Service. A login and password server standard originally developed for ISP telephone modem bank service accesses. RADIUS is now widely used for any general login process.

Roaming - A wireless LAN mobile user moves around an ESS and maintains a continuous connection to the infrastructure network.

RTS Threshold - Transmitters contending for the medium may not be aware of each other. RTS/CTS mechanism can solve this “Hidden Node Problem.” If the packet size is smaller than the preset RTS Threshold size, the RTS/CTS mechanism will NOT be enabled.

Summit 300-48TM - Extreme Networks 48 port 10/100 switch with four GBIC ports, PoE, and **Altitude 300-2TM** configuration software.

UNII - Unlicensed National Information Infrastructure are regulated but unlicensed bands of frequency in the region of 5 MHz. The amount of bandwidth available and their positions vary among the regulator.

Wireless Port - An internetworking device that seamlessly connects wired and wireless networks.

