



**Ultratech's
Accreditations:**



0685



31040/SIT



C-1376



46390-2049



200093-0



SL2-IN-E-1119R

3000 Bristol Circle,
Oakville, Ontario,
Canada L6H 6G4

Tel.: (905) 829-1570
Fax.: (905) 829-8050

Website: www.ultratech-labs.com
Email: vic@ultratech-labs.com

Apr. 12, 2007

TIMCO ENGINEERING INC.

P.O. Box 370
849 N.W. State Road 45
Newberry, Florida
USA 32669

Subject: Class II Permissive Change under FCC Part 15, Subpart C, Sec. 15.247 - Digital Modulation Transmitters operating in the frequency band 2400 - 2483.5 MHz and 5.725-5.850 GHz and FCC Part 15, Subpart E - Unlicensed National Information Infrastructure Devices operating in the Frequency Bands 5.15-5.25 GHz (indoor operation only) and 5.25-5.35 GHz.

Product: Altitude 350-2 Access Point
Model No.: Altitude 350-2 Integ 15938 and Altitude 350-2 Detach 15939
FCC ID: RJF-A3502A

Dear Sir/Madam,

As appointed agent for **Extreme Networks Inc.**, we would like to submit this application for FCC class II permissive change authorization of the above product. Please review all required documents uploaded to TIMCO Upload Web Site.

The description of the Class II modifications are provided in Exhibit 1, Section 1.1 of the test report, Our File Number: **CNI-080FCC15CE 041207**

If you have any queries, please do not hesitate to contact us.

Yours truly,

Tri Minh Luu, P. Eng.,
V.P., Engineering

Encl.



**Ultratech's
Accreditations:**



0685



C-1376



3000 Bristol Circle,
Oakville, Ontario,
Canada L6H 6G4

Tel.: (905) 829-1570
Fax.: (905) 829-8050

Website: www.ultratech-labs.com
Email: vic@ultratech-labs.com

Apr. 12, 2007

Extreme Networks Inc.
3585 Monroe Street
Santa Clara, CA 95051
USA

Attn.: Mr. Mark Darula

Subject: Class II Permissive Change under FCC Part 15, Subpart C, Sec. 15.247 - Digital Modulation Transmitters operating in the frequency band 2400 - 2483.5 MHz and 5.725-5.850 GHz and FCC Part 15, Subpart E - Unlicensed National Information Infrastructure Devices operating in the Frequency Bands 5.15-5.25 GHz (indoor operation only) and 5.25-5.35 GHz.

Product: Altitude 350-2 Access Point
Model No.: Altitude 350-2 Integ 15938 and Altitude 350-2 Detach 15939
FCC ID: RJF-A3502A

Dear Mr. Darula,

The product sample, as provided by you, has been tested and found to comply with FCC Part 15, Subpart C, Section 15.247 - Digital Modulation Transmitters operating in the frequency band 2400 - 2483.5 MHz and 5.725-5.850 GHz and FCC Part 15, Subpart E - Unlicensed National Information Infrastructure Devices operating in the frequency bands 5.15-5.25 GHz (indoor operation only) and 5.25-5.35 GHz.

Enclosed you will find copy of the engineering report. If you have any queries, please do not hesitate to contact us.

Yours truly,

Tri Minh Luu, P. Eng.,
V.P., Engineering

Encl.

ENGINEERING TEST REPORT



Altitude 350-2 Access Point
Model No.: Altitude 350-2 Integ 15938 & Altitude 350-2 Detach 15939
(Class II Permissive Changes for RoHS Compliance)

FCC ID: RJF-A3502A

Applicant:

Extreme Networks Inc.
3585 Monroe Street
Santa Clara, CA 95051, USA

In Accordance With

FEDERAL COMMUNICATIONS COMMISSION (FCC)
Part 15, Subpart C, Section 15.247 - Digital Modulation Transmitters Operating in the
Frequency Band 2400 - 2483.5 MHz and 5.725-5.850 GHz
&
Part 15, Subpart E
Unlicensed National Information Infrastructure Devices
Operating in Frequency Bands 5.15-5.25 GHz (indoor operation only) and 5.25-5.35 GHz

UltraTech's File No.: CNI-080FCC15CE – 041207

This Test report is Issued under the Authority of
Tri M. Luu, Professional Engineer,
Vice President of Engineering
UltraTech Group of Labs



Date: Apr. 12, 2007

Report Prepared by: Tri Luu, P.Eng.

Tested by: Mr. Hung Trinh, RFI Technologist

Issued Date: Apr. 12, 2007

Test Dates: Aug. 17 – Dec. 14, 2006

- *The results in this Test Report apply only to the sample(s) tested, and the sample tested is randomly selected.*
- *This report must not be used by the client to claim product endorsement by NVLAP or any agency of the US Government.*

UltraTech

3000 Bristol Circle, Oakville, Ontario, Canada, L6H 6G4
Tel.: (905) 829-1570 Fax.: (905) 829-8050

Website: www.ultratech-labs.com, Email: vic@ultratech-labs.com, Email: tri@ultratech-labs.com



0685



31040/SIT



C-1376



46390-2049



200093-0



SL2-IN-E-1119R

TABLE OF CONTENTS

EXHIBIT 1. INTRODUCTION	4
1.1. SCOPE	4
1.2. RELATED SUBMITTAL(S)/GRANT(S)	4
1.3. NORMATIVE REFERENCES	5
EXHIBIT 2. PERFORMANCE ASSESSMENT	6
2.1. CLIENT INFORMATION	6
2.2. EQUIPMENT UNDER TEST (EUT) INFORMATION	6
2.3. EUT'S TECHNICAL SPECIFICATIONS	7
2.4. LIST OF EUT'S PORTS	8
2.5. ANCILLARY EQUIPMENT	9
2.6. GENERAL TEST SETUP	9
EXHIBIT 3. EUT OPERATING CONDITIONS AND CONFIGURATIONS DURING TESTS	11
3.1. CLIMATE TEST CONDITIONS	11
3.2. OPERATIONAL TEST CONDITIONS & ARRANGEMENT FOR TESTS	11
EXHIBIT 4. SUMMARY OF TEST RESULTS	13
4.1. LOCATION OF TESTS	13
4.2. MODIFICATIONS INCORPORATED IN THE EUT FOR COMPLIANCE PURPOSES	13
4.3. APPLICABILITY & SUMMARY OF EMC EMISSION TEST RESULTS @ FCC 15.247	13
4.4. APPLICABILITY & SUMMARY OF EMC EMISSION TEST RESULTS @ FCC 15.407	14
4.5. RF EXPOSURE & INTERMODULATION FOR MULTIPLE TRANSMISSION @ FCC 15.247 & 15.407	14
EXHIBIT 5. TEST DATA [§ 15.247 – OPERATION IN 2400-2483.5 MHZ AND 5725-5850 MHZ]	15
5.1. OUTPUT POWER (CONDUCTED) [§ 15.247(B)]	15
5.1.1. Limits	15
5.1.2. Test Equipment List	15
5.1.3. Method of Measurements & Test Arrangement	15
5.1.4. Test Data	17
5.2. SPURIOUS EMISSIONS (RADIATED @ 3 METERS) [§ 15.247(c), 15.209 & 15.205]	21
5.2.1. Limits	21
5.2.2. Method of Measurements	22
5.2.3. Test Equipment List	22
5.2.4. Photographs Test Setup	22
5.2.5. Test Data	23
EXHIBIT 6. TEST DATA [§ 15.407 – OPERATION IN 5.15-5.35 GHZ]	99
6.1. POWER LIMITS [§ 15.407(A)]	99
6.1.1. Limits	99
6.1.2. Method of Measurements	99
6.1.3. Test Arrangement	102
6.1.4. Test Equipment List	102
6.1.5. Test Data	103
6.2. UNDESIRE EMISSIONS (RADIATED @ 3 METERS) [§ 15.407(B)]	117
6.2.1. Limits	117
6.2.2. Method of Measurements	118
6.2.3. Test Arrangement	118

6.2.4.	<i>Test Equipment List</i>	118
6.2.5.	<i>Photographs Test Setup</i>	118
6.2.6.	<i>Test Data</i>	119
EXHIBIT 7.	MEASUREMENT UNCERTAINTY	124
7.1.	RADIATED EMISSION MEASUREMENT UNCERTAINTY	124
EXHIBIT 8.	MEASUREMENT METHODS	125
8.1.	GENERAL TEST CONDITIONS	125
8.1.1.	<i>Normal temperature and humidity</i>	125
8.1.2.	<i>Normal power source</i>	125
8.1.3.	<i>Operating Condition of Equipment under Test</i>	125
8.2.	SPURIOUS EMISSIONS (RADIATED)	126

EXHIBIT 1. INTRODUCTION

1.1. SCOPE

Reference:	<ul style="list-style-type: none">FCC Part 15, Subpart C, Section 15.247FCC Part 15, Subpart E - Unlicensed National Information Infrastructure Devices
Title:	Code of Federal Regulations (CFR) Title 47 - Telecommunication, Part 15
Purpose of Test:	<ul style="list-style-type: none">The tests covered in this test report were performed for Class II Permissive Change Authorization in accordance with FCC 15, Subpart C, Section 14.247 for operation in the Frequency Bands 2400 - 2483.5 MHz and 5.725-5.850 GHz and FCC Part 15, Subpart E for Unlicensed National Information Infrastructure (U-NII) devices operating in the 5.15-5.25 GHz (indoor operation only) and 5.25-5.35 GHz bands.
Environmental Classification:	<ul style="list-style-type: none">ResidentialLight-industry, CommercialIndustry
Class II Modifications applied to the original product:	<p>Some electronic components were changed as compared with the original certified product in order to bring the Access Point in compliance with the European Directive 2002/95/EC OF THE EUROPEAN PARLIAMENT AND OF THE COUNCIL of 27 January 2003 on the restriction of the use of certain hazardous substances in electrical and electronic equipment (RoHS). Additional changes were made for design upgrade. The details of modification are as below:</p> <p>Design Upgrade: PoE integration (updated DC/DC Converter circuit) Addition of a reset button circuit New over-voltage protection circuitry Removal of RS232 driver circuitry Removal of JTAG connector New PCB layout (RF section updated)</p> <p>Additional changes for RoHS compliance. There are several components that have been changed to functionally equivalent RoHS versions.</p> <p>The component changes for the design upgrades and RoHS compliance include: resistors, capacitors, inductors, diodes, transistors, LEDs, ICs, FLASH IC, RF switch, RF filter, transformer, crystal, fuse, PCB, header.</p>

1.2. RELATED SUBMITTAL(S)/GRANT(S)

None.

1.3. NORMATIVE REFERENCES

Publication	Year	Title
FCC CFR Part 15	2006	Code of Federal Regulations – Telecommunication
ANSI C63.4	2003	American National Standard for Methods of Measurement of Radio-Noise Emissions from Low-Voltage Electrical and Electronic Equipment in the Range of 9 kHz to 40 GHz
CISPR 22 EN 55022 +A1 +A2	2003-04-10 1998 2000 2003	Information Technology Equipment - Radio Disturbance Characteristics - Limits and Methods of Measurement
CISPR 16-1-1	2003	Specification for Radio Disturbance and Immunity measuring apparatus and methods
FCC Test Procedures	Mar. 23, 2005	Measurement of Digital Transmission Systems. Operating under Section 15.247
FCC Docket	2003	Revision of Parts 2 and 15 of Commission’s Rules to permit Unlicensed National Information Infrastructure (U-NII) Devices in the 5 GHz band
FCC Procedures	2001	Guidelines for Assessing Unlicensed National Information Infrastructure Devices (UNII)-Part 15 Subpart E - November 2001

EXHIBIT 2. PERFORMANCE ASSESSMENT

2.1. CLIENT INFORMATION

APPLICANT	
Name:	Extreme Networks Inc.
Address:	3585 Monroe Street Santa Clara, CA 95051 United States
Contact Person:	Mr. Mark Darula Phone #: 408 579-3249 Fax #: 408 579-3000 Email Address: mdarula@extremenetworks.com

MANUFACTURER	
Name:	Celestica Kladno SRO
Address:	Billundska 311 27201 Kladno Czech Republic
Contact Person:	Jozef Trabalka Phone #: 420 312 821 100 Fax #: n/a

2.2. EQUIPMENT UNDER TEST (EUT) INFORMATION

Brand Name:	Extreme Networks Inc.
Product Name:	Altitude 350-2 Access Point
Model Name or Number:	Altitude 350-2 Integ 15938 & Altitude 350-2 Detach 15939 The product is marketed with one of four optional models to differentiate between the external antennas and internal antennas. The unit with internal antennas are be identified and labeled as Models Altitude 350-2 Integ 15938 and the one with external antennas are identified and labeled as Altitude 350-2 Detach 15939 .
Serial No.:	2000006232051002 (external antenna) 2000006232051045 (internal antenna)
Part No.:	S30122-X8000-X33 (external antenna) S30122-X8000-X32 (internal antenna)
CPU's Frequencies:	25 MHz and 40 MHz
Power input source:	Generic External AC/DC Adapter

2.3. EUT'S TECHNICAL SPECIFICATIONS

TRANSMITTER	
Equipment Type:	Base / Mobile
Intended Operating Environment:	<ul style="list-style-type: none"> ▪ Residential ▪ Commercial, light industry & heavy industry
Power Supply Requirement:	6.0V @ 2.0A at input of unit using a generic FCC, IC & CE approved external AC-DC adaptor.
RF Output Power Rating: Model ALTITUDE 350-2 DETACH 15939 with External Antennas: <ul style="list-style-type: none"> ▪ 802.11b (2412-2462 MHz): ▪ 802.11g (2412-2462 MHz): ▪ 802-11a (5180-5240 MHz): ▪ 802-11a (5260-5320 MHz): ▪ 802-11a (5745-5825 MHz): Model ALTITUDE 350-2 INTEG 15938 with Internal Antennas: <ul style="list-style-type: none"> ▪ 802.11b (2412-2462 MHz): ▪ 802.11g (2412-2462 MHz): ▪ 802-11a (5180-5240 MHz): ▪ 802-11a (5260-5320 MHz): ▪ 802-11a (5745-5825 MHz): 	Model ALTITUDE 350-2 DETACH 15939 with External Antennas: <ul style="list-style-type: none"> ▪ 19.3 to 20.8 dBm (Power Settings: 19-20 dBm); ▪ 19.9 to 23.1 dBm (Power Settings: 15-20 dBm); ▪ 14.7 to 15.0 dBm (Power Settings: 20 dBm) ▪ 14.2 to 15.0 dBm (Power Settings: 20 dBm) ▪ 21.9 to 22.0 dBm (Power Settings: 20 dBm) Model ALTITUDE 350-2 INTEG 15938 with Internal Antennas: <ul style="list-style-type: none"> ▪ 20.6 to 21.9 dBm (Power Settings: 18.5-20 dBm); ▪ 21.0 to 23.1 dBm (Power Settings: 14-18 dBm); ▪ 14.1 to 14.4 dBm (Power Settings: 17 dBm) ▪ 14.6 to 14.8 dBm (Power Settings: 18 dBm) ▪ 22.8 to 23.0 dBm (Power Settings: 18 dBm) <p>Please refer the output power measurements in this test report for details</p>
Operating Frequency Range:	<ul style="list-style-type: none"> ▪ 802.11b (2412-2462 MHz) ▪ 802.11g (2412-2462 MHz) ▪ 802-11a (5180-5240 MHz) ▪ 802-11a (5260-5320 MHz) ▪ 802-11a (5745-5825 MHz)
RF Output Impedance:	50 ohms
Channel Spacing:	<ul style="list-style-type: none"> ▪ 5 MHz for 802.11b/g ▪ 20MHz for 802.11a
Occupied Bandwidths:	<ul style="list-style-type: none"> ▪ 802.11b (2412-2462 MHz) ▪ 802.11g (2412-2462 MHz) ▪ 802-11a (5180-5240 MHz) ▪ 802-11a (5260-5320 MHz) ▪ 802-11a (5745-5825 MHz)
Duty Cycle:	100%
Modulation Type:	DSSS (BPSK, QPSK), CCK (BPSK, QPSK), and OFDM (BPSK, QPSK, 16QAM, 64QAM)

Antenna Connector Type:	<ul style="list-style-type: none"> ▪ Non-integral (2 external antennas, using RPSMA connectors for mating). ▪ Integral (2 internal antennas, each is connected to the printed circuit board by means of UFL connection inside the enclosure)
Antenna Description:	<p>External: Manufacturer: Joymax Electronics Co. Type: Omnidirectional Tri Band Swivel RPSMA Interface Antenna Model: FWX-614RSXXX-514 Frequency Range: 2300-2500MHz and 4.9GHz – 5.85GHz In/Out Impedance: 50 Ohms Gain: 4 dBi (2.45 GHz) and 5 dBi (5.5 GHz)</p> <p>Internal: Manufacturer: Actiontec Type: Omnidirectional Tri Band Embedded Antenna Model: 0180-0002G000 (right antenna), 0180-0003G000 (left antenna) Frequency Range: 2300 - 2500 MHz and 4.9 – 5.85 GHz In/Out Impedance: 50 Ohms Gain: 4.3 dBi (Max.)</p>

RECEIVER	
Operating Frequency Range:	<ul style="list-style-type: none"> ▪ 802.11b (2412-2462 MHz) ▪ 802.11g (2412-2462 MHz) ▪ 802-11a (5180-5240 MHz) ▪ 802-11a (5260-5320 MHz) ▪ 802-11a (5745-5825 MHz)
RF Output Impedance:	50 ohms
Channel Spacing:	5 MHz for 802.11b/g and 20MHz for 802.11a
Antenna Connector Type:	Same as transmitter
Antenna Description:	Same as transmitter

2.4. LIST OF EUT'S PORTS

Port Number	EUT's Port Description	Number of Identical Ports	Connector Type	Cable Type (Shielded/Non-shielded)
1	Ethernet port	1	RJ45	Non-shielded
2	DC in port	1	RAPC712 equivalent	Non-shielded
3	RF Antenna port (external antenna version only)	2	Reverse-polarity SMA (RPSMA)	N/A – mates directly to antennae.

Note: The internal antenna unit does not have RF Antenna Port.

2.5. ANCILLARY EQUIPMENT

The EUT was tested while connected to the following representative configuration of ancillary equipment necessary to exercise the ports during tests:

Ancillary Equipment # 1	
Description:	Laptop Computer
Brand name:	Dell
Model Name or Number:	PP01L
FCC Approval:	FCC Class B -DoC
Connected to EUT's Port:	RJ-45 Ethernet

2.6. GENERAL TEST SETUP

Test Configuration #1:

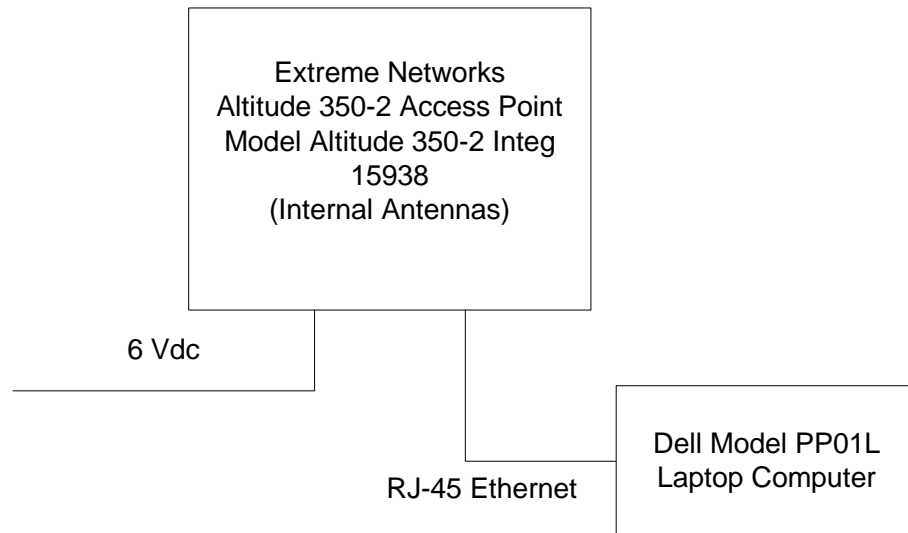

Test Configuration #2:

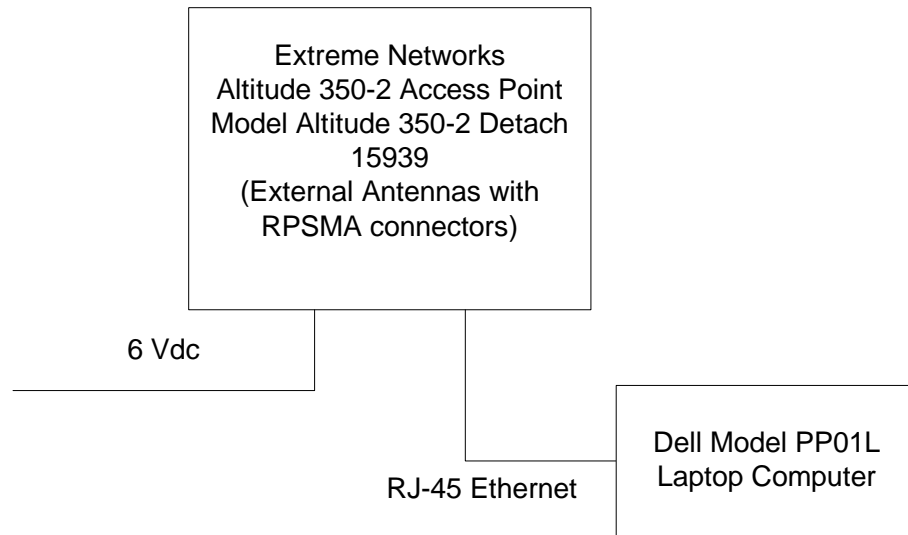

EXHIBIT 3. EUT OPERATING CONDITIONS AND CONFIGURATIONS DURING TESTS

3.1. CLIMATE TEST CONDITIONS

The climate conditions of the test environment are as follows:

Temperature:	21°C
Humidity:	51%
Pressure:	102 kPa
Power input source:	6 Vdc using external AC/DC adaptor

3.2. OPERATIONAL TEST CONDITIONS & ARRANGEMENT FOR TESTS

Operating Modes:	<ul style="list-style-type: none">▪ Each of lowest, middle and highest channel frequencies transmits continuously for emissions measurements.▪ The EUT operates in normal Direct Sequence mode for occupancy duration, and frequency separation.
Special Test Software:	Special software is provided by the Applicant to select and operate the EUT at each channel frequency continuously. For example, the transmitter will be operated at each of lowest, middle and highest frequencies individually continuously during testing.
Special Hardware Used:	N/A
Transmitter Test Antenna:	The EUT is tested with the antenna fitted in a manner typical of normal intended use.

Transmitter Test Signals	
<p>Frequency(ies) Tested: (lowest, middle & highest frequencies in the frequency range of operation.)</p> <ul style="list-style-type: none"> ▪ 802.11b (2412-2462 MHz) ▪ 802.11g (2412-2462 MHz) ▪ 802-11a (5180-5240 MHz) ▪ 802-11a (5260-5320 MHz) ▪ 802-11a (5745-5825 MHz) 	<ul style="list-style-type: none"> ▪ 2412, 2437 and 2462 MHz ▪ 2412, 2417, 2422, 2427, 2432, 2437, 2442, 2447 2452, 2457 and 2462 MHz. ▪ 5180, 5220 and 5240 MHz ▪ 5260, 5300 and 5320 MHz ▪ 5745, 5765, 5785, 5805 and 5825 MHz
<p>Transmitter Wanted Output Test Signals:</p> <p>Model ALTITUDE 350-2 DETACH 15939 with External Antennas:</p> <ul style="list-style-type: none"> ▪ 802.11b (2412-2462 MHz): ▪ 802.11g (2412-2462 MHz): ▪ 802-11a (5180-5240 MHz): ▪ 802-11a (5260-5320 MHz): ▪ 802-11a (5745-5825 MHz): <p>Model ALTITUDE 350-2 INTEG 15938 with Internal Antennas:</p> <ul style="list-style-type: none"> ▪ 802.11b (2412-2462 MHz): ▪ 802.11g (2412-2462 MHz): ▪ 802-11a (5180-5240 MHz): ▪ 802-11a (5260-5320 MHz): ▪ 802-11a (5745-5825 MHz): 	<p>Model ALTITUDE 350-2 DETACH 15939 with External Antennas:</p> <ul style="list-style-type: none"> ▪ 19.3 to 20.8 dBm (Power Settings: 19-20 dBm); ▪ 19.9 to 23.1 dBm (Power Settings: 15-20 dBm); ▪ 14.7 to 15.0 dBm (Power Settings: 20 dBm) ▪ 14.2 to 15.0 dBm (Power Settings: 20 dBm) ▪ 21.9 to 22.0 dBm (Power Settings: 20 dBm) <p>Model ALTITUDE 350-2 INTEG 15938 with Internal Antennas:</p> <ul style="list-style-type: none"> ▪ 20.6 to 21.9 dBm (Power Settings: 18.5-20 dBm); ▪ 21.0 to 23.1 dBm (Power Settings: 14-18 dBm); ▪ 14.1 to 14.4 dBm (Power Settings: 17 dBm) ▪ 14.6 to 14.8 dBm (Power Settings: 18 dBm) ▪ 22.8 to 23.0 dBm (Power Settings: 18 dBm) <p>Please refer the output power measurements in this test report for details</p>

EXHIBIT 4. SUMMARY OF TEST RESULTS

4.1. LOCATION OF TESTS

All of the measurements described in this report were performed at Ultratech Group of Labs located in the city of Oakville, Province of Ontario, Canada.

- AC Powerline Conducted Emissions were performed in UltraTech's shielded room, 16'(L) by 12'(W) by 12'(H).
- Radiated Emissions were performed at the Ultratech's 3-10 TDK Semi-Anechoic Chamber situated in the Town of Oakville, province of Ontario. This test site been calibrated in accordance with ANSI C63.4, and found to be in compliance with the requirements of Sec. 2.948 of the FCC Rules. The descriptions and site measurement data of the Oakville 3-10 TDK Semi-Anechoic Chamber has been filed with FCC office (FCC File No.: 31040/SIT 1300B3) and Industry Canada office (Industry Canada File No.: IC2049-1). Last Date of Site Calibration: June. 20, 2005.

4.2. MODIFICATIONS INCORPORATED IN THE EUT FOR COMPLIANCE PURPOSES

None.

4.3. APPLICABILITY & SUMMARY OF EMC EMISSION TEST RESULTS @ FCC 15.247

FCC Section(s)	Test Requirements	Compliance (Yes/No)
15.107(a) & 207	AC Power Conducted Emissions	Note (1)
15.247(a)(2)	6dB Bandwidth of a Digital Modulation System	Note (1)
15.247(b) & 1.1310	Maximum Peak Power (Conducted)	Yes
15.247(c)	RF Conducted Spurious Emissions at the Transmitter Antenna Terminal	Note (1)
15.247(d)	Transmitted Power Density of a Digital Modulation System	Note (1)
15.247(c), 15.209 & 15.205	Transmitter Radiated Emissions	Yes
FCC Part 15, Sub. B, Section 15.109	Class B Radiated Emissions	Yes

Notes: (1) Not required to be repeated based on the nature of modifications

Notes:

- (1) Tests are not required to be repeated based on the nature of modifications which will not affect the original test results.

- All test results contained in this engineering test report are traceable to National Institute of Standards and Technology (NIST)

4.4. APPLICABILITY & SUMMARY OF EMC EMISSION TEST RESULTS @ FCC 15.407

FCC Section(s)	Test Requirements	Compliance (Yes/No)
15.203 & 15.204	Any U-NII device that operates in the 5.15-5.25 GHz (indoor operation only) band shall use a transmitting antenna that is an integral part of the device	Yes.
15.407(e)	Within the 5.15-5.25 GHz band, U-NII devices will be restricted to indoor operations to reduce any potential for harmful interference to co-channel MSS operations	Yes.
15.407(c)	The device shall automatically discontinue transmission in case of either absence of information to transmit or operational failure. These provisions are not intended to preclude the transmission of control or signalling information or the use of repetitive codes used by certain digital technologies to complete frame or burst intervals. Applicants shall include in their application for equipment authorization a description of how this requirement is met.	Yes.
15.407(g)	Manufacturers of U-NII devices are responsible for ensuring frequency stability such that an emission is maintained within the band of operation under all conditions of normal operation as specified in the users manual	Yes.
15.407(a)	Power Limits (Peak Transmit Power and Power Spectral Density) & 26 dB Bandwidth	Yes. Only Transmit Power need to be re-test to ensure the continuing compliance with the original grant
15.407(b)	Band-edge & Undesired Emissions (Conducted)	N/A for Class II Permissive Change
15.407(b), 15.205 & 15.209	Band-edge & Undesired Emissions (Radiated)	Yes.
15.107 & 15.207	Class B - AC Power Conducted Emissions on Tx, Rx and standby modes	Yes. A separate test report will be provided upon request.
15.109(a)	Class B - Radiated Emissions from Unintentional Radiators	Yes. A separate test report will be provided upon request.

4.5. RF Exposure & Intermodulation for Multiple Transmission @ FCC 15.247 & 15.407

FCC Section(s)	Test Requirements	Compliance (Yes/No)
15.407(f), 1.1307, 1.1310, 2.1091 & 2.1093	RF Exposure Limit	N/A because the power ratings are unchanged
N/A	Intermodulation	N/A because the power ratings are unchanged

EXHIBIT 5. TEST DATA [§ 15.247 – OPERATION IN 2400-2483.5 MHz and 5725-5850 MHz]

5.1. OUTPUT POWER (CONDUCTED) [§ 15.247(b)]

5.1.1. Limits

- **FCC 15.247(b)(3):** Maximum peak output power of the transmitter shall not exceed 1 Watt.
- **FCC 15.247(b)(4):** If transmitting antennas of directional gain greater than 6 dBi are used the peak output power from the intentional radiator shall be reduced below the stated values, as appropriate, by the amount in dB that the directional gain of the antenna exceeds 6 dBi.

5.1.2. Test Equipment List

Test Instruments	Manufacturer	Model No.	Serial No.	Frequency Range
Spectrum Analyzer/ EMI Receiver	Rohde & Schawrz	FSEK20/B4/B21	834157/005	9 kHz – 40 GHz with external mixer
RF Signal Generator	Hewlett Packard	HP 83752B	3610A00457	0.01 – 20 GHz
67297 RF Detector (Diode Detector)	Herotex	DZ122-553	63400	..
Storage Oscilloscope	Philips	PM3320A	ST9907959	--

5.1.3. Method of Measurements & Test Arrangement

Refer to “FCC Measurement of Digital Transmission Systems Operating under Section 15.247 - March 23, 2005”

This is an RF conducted test. Use a direct connection between the antenna port of the transmitter, peak diode detector and oscilloscope, through suitable attenuation. Power Output Option 1, total peak output power measurement, was used to test this DTS device.

Power Output Option 1:

The total peak power was measured using peak detector diode method as described below:

Step 1:

- Connect the transmitter output to a diode detector through an attenuator
- Connect the diode detector to the vertical channel of an oscilloscope.
- Observe and record the y parameter of the DC level on the oscilloscope.

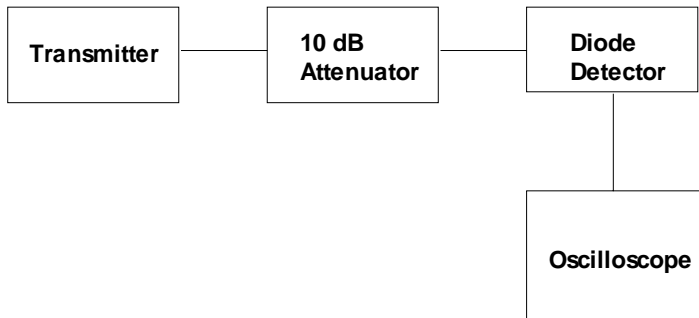

Step 2: Peak Power Measurements

- Replace the transmitter by a RF signal generator
- Set the signal generator frequency be the same as the transmitter frequency
- Adjust the rf output level of the RF signal generator until the DC level on the oscilloscope is same as that (y) recorded in step 1.
- Measure the RF signal generator output level using a power meter
- Calculate the total peak power (Pp) by adding the signal generator level with the attenuator value and the cable loss.
- Calculate the peak EIRP: $EIRP = Pp + G$

Where: EIRP: Effective isotropic radiated power in dBm

Pp: Peak conducted power in dBm

G: Transmitter antenna gain in dBi

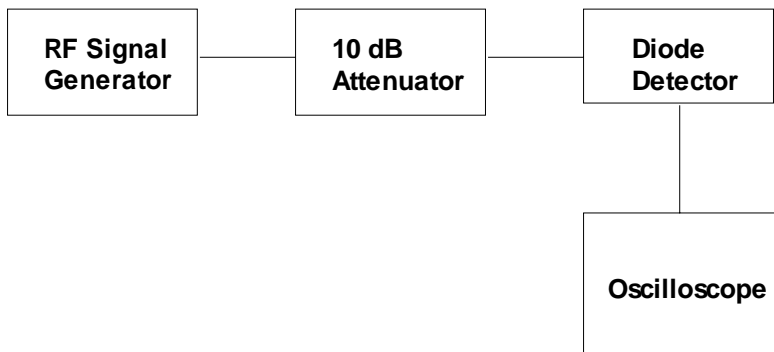

5.1.4. Test Data

Method of Output Power Measurements:

Option #1:	Total Peak Power using Peak Diode Detector for both 802.11b and 802.11g
------------	---

5.1.4.1. Model ALTITUDE 350-2 DETACH 15939 with External Antenna, Modulation: IEEE 802.11b

Frequency (MHz)	Modulation	Power Setting (dBm)	(full bandwidth) Peak Power at Antenna Terminals (dBm)	Maximum Antenna Gain (dBi)	(full bandwidth) Peak EIRP (dBm)	Limit for Power at Antenna Port (dBm)	Limit for EIRP (dBm)
2412	CCK @ 11 Mb/s	19.5	19.4	4.0	23.4	30.0	36.0
2417	CCK @ 11 Mb/s	19.0	19.3	4.0	23.3	30.0	36.0
2422	CCK @ 11 Mb/s	20.0	20.7	4.0	24.7	30.0	36.0
2427	CCK @ 11 Mb/s	20.0	20.6	4.0	24.6	30.0	36.0
2432	CCK @ 11 Mb/s	20.0	20.8	4.0	24.8	30.0	36.0
2437	CCK @ 11 Mb/s	20.0	20.8	4.0	24.8	30.0	36.0
2442	CCK @ 11 Mb/s	20.0	20.7	4.0	24.7	30.0	36.0
2447	CCK @ 11 Mb/s	20.0	20.7	4.0	24.7	30.0	36.0
2452	CCK @ 11 Mb/s	20.0	20.7	4.0	24.7	30.0	36.0
2457	CCK @ 11 Mb/s	20.0	20.7	4.0	24.7	30.0	36.0
2462	CCK @ 11 Mb/s	19.5	20.4	4.0	24.4	30.0	36.0

Note: The above tests were performed with maximum data rate (CCK @ 11 Mb/s), the results were found to be the same for other modulations with lower data rates.

5.1.4.2. Model ALTITUDE 350-2 DETACH 15939 with External Antenna, Modulation: IEEE 802.11g

Frequency (MHz)	Modulation	Power Setting (dBm)	(full bandwidth) Peak Power at Antenna Terminals (dBm)	Maximum Antenna Gain (dBi)	(full bandwidth) Peak EIRP (dBm)	Limit for Power at Antenna Port (dBm)	Limit for EIRP (dBm)
2412	64QAM @ 54 Mb/s	15.0	20.0	4.0	24.0	30.0	36.0
2417	64QAM @ 54 Mb/s	17.0	21.7	4.0	25.7	30.0	36.0
2422	64QAM @ 54 Mb/s	18.5	22.3	4.0	26.3	30.0	36.0
2427	64QAM @ 54 Mb/s	19.0	22.6	4.0	26.6	30.0	36.0
2432	64QAM @ 54 Mb/s	20.0	23.1	4.0	27.1	30.0	36.0
2437	64QAM @ 54 Mb/s	20.0	23.1	4.0	27.1	30.0	36.0
2442	64QAM @ 54 Mb/s	20.0	23.1	4.0	27.1	30.0	36.0
2447	64QAM @ 54 Mb/s	19.5	22.9	4.0	26.9	30.0	36.0
2452	64QAM @ 54 Mb/s	19.0	22.7	4.0	26.7	30.0	36.0
2457	64QAM @ 54 Mb/s	18.0	22.1	4.0	26.1	30.0	36.0
2462	64QAM @ 54 Mb/s	15.0	19.9	4.0	23.9	30.0	36.0

Note: The above tests were performed with maximum data rate (64QAM @ 54 Mb/s), the results were found to be the same for other modulations with lower data rates.

5.1.4.3. Model ALTITUDE 350-2 DETACH 15939 with External Antenna, Modulation: IEEE 802.11a

Frequency (MHz)	Modulation	Power Setting (dBm)	(full bandwidth) Peak Power at Antenna Terminals (dBm)	Maximum Antenna Gain (dBi)	(full bandwidth) Peak EIRP (dBm)	Limit for Power at Antenna Port (dBm)	Limit for EIRP (dBm)
5745	64QAM @ 54 Mb/s	20.0	22.0	5.0	27.0	30.0	36.0
5765	64QAM @ 54 Mb/s	20.0	22.0	5.0	27.0	30.0	36.0
5785	64QAM @ 54 Mb/s	20.0	22.0	5.0	27.0	30.0	36.0
5805	64QAM @ 54 Mb/s	20.0	22.0	5.0	27.0	30.0	36.0
5825	64QAM @ 54 Mb/s	20.0	21.9	5.0	26.9	30.0	36.0

Note: The above tests were performed with maximum data rate (64QAM @ 54 Mb/s), the results were found to be the same for other modulations with lower data rates.

5.1.4.4. Model ALTITUDE 350-2 INTEG 15938 with Internal Antenna, Modulation: IEEE 802.11b

Frequency (MHz)	Modulation	Power Setting (dBm)	(full bandwidth) Peak Power at Antenna Terminals (dBm)	Maximum Antenna Gain (dBi)	(full bandwidth) Peak EIRP (dBm)	Limit for Power at Antenna Port (dBm)	Limit for EIRP (dBm)
2412	CCK @ 11Mb/s	18.5	20.6	4.3	24.9	30.0	36.0
2417	CCK @ 11Mb/s	19.0	20.9	4.3	25.2	30.0	36.0
2422	CCK @ 11Mb/s	20.0	21.8	4.3	26.1	30.0	36.0
2427	CCK @ 11Mb/s	20.0	21.9	4.3	26.2	30.0	36.0
2432	CCK @ 11Mb/s	20.0	21.3	4.3	25.6	30.0	36.0
2437	CCK @ 11Mb/s	20.0	21.5	4.3	25.8	30.0	36.0
2442	CCK @ 11Mb/s	20.0	21.8	4.3	26.1	30.0	36.0
2447	CCK @ 11Mb/s	20.0	21.4	4.3	25.7	30.0	36.0
2452	CCK @ 11Mb/s	20.0	21.4	4.3	25.7	30.0	36.0
2457	CCK @ 11Mb/s	20.0	21.4	4.3	25.7	30.0	36.0
2462	CCK @ 11Mb/s	20.0	20.9	4.3	25.2	30.0	36.0

Note: The above tests were performed with maximum data rate (CCK @ 11 Mb/s), the results were found to be the same for other modulations with lower data rates.

5.1.4.5. Model ALTITUDE 350-2 INTEG 15938 with Internal Antenna, Modulation: IEEE 802.11g

Frequency (MHz)	Modulation	Power Setting (dBm)	(full bandwidth) Peak Power at Antenna Terminals (dBm)	Maximum Antenna Gain (dBi)	(full bandwidth) Peak EIRP (dBm)	Limit for Power at Antenna Port (dBm)	Limit for EIRP (dBm)
2412	64QAM @ 54Mb/s	14.0	21.0	4.3	25.3	30.0	36.0
2417	64QAM @ 54Mb/s	16.0	22.1	4.3	26.4	30.0	36.0
2422	64QAM @ 54Mb/s	17.5	22.8	4.3	27.1	30.0	36.0
2427	64QAM @ 54Mb/s	18.0	23.0	4.3	27.3	30.0	36.0
2432	64QAM @ 54Mb/s	18.0	23.0	4.3	27.3	30.0	36.0
2437	64QAM @ 54Mb/s	18.0	22.9	4.3	27.2	30.0	36.0
2442	64QAM @ 54Mb/s	18.0	23.1	4.3	27.4	30.0	36.0
2447	64QAM @ 54Mb/s	18.0	22.9	4.3	27.2	30.0	36.0
2452	64QAM @ 54Mb/s	18.0	23.0	4.3	27.3	30.0	36.0
2457	64QAM @ 54Mb/s	18.0	22.7	4.3	27.0	30.0	36.0
2462	64QAM @ 54Mb/s	16.0	21.3	4.3	25.6	30.0	36.0

Note: The above tests were performed with maximum data rate (64QAM @ 54 Mb/s), the results were found to be the same for other modulations with lower data rates.

5.1.4.6. Model ALTITUDE 350-2 INTEG 15938 with Internal Antenna, Modulation: IEEE 802.11a

Frequency (MHz)	Modulation	Power Setting (dBm)	(full bandwidth) Peak Power at Antenna Terminals (dBm)	Maximum Antenna Gain (dBi)	(full bandwidth) Peak EIRP (dBm)	Limit for Power at Antenna Port (dBm)	Limit for EIRP (dBm)
5745	64QAM @ 54Mb/s	18.0	23.0	4.3	27.3	30.0	36.0
5765	64QAM @ 54Mb/s	18.0	22.9	4.3	27.2	30.0	36.0
5785	64QAM @ 54Mb/s	18.0	22.8	4.3	27.1	30.0	36.0
5805	64QAM @ 54Mb/s	18.0	22.8	4.3	27.1	30.0	36.0
5825	64QAM @ 54Mb/s	18.0	22.8	4.3	27.1	30.0	36.0

Note: The above tests were performed with maximum data rate (64QAM @ 54 Mb/s), the results were found to be the same for other modulations with lower data rates.

5.2. SPURIOUS EMISSIONS (RADIATED @ 3 METERS) [§ 15.247(c), 15.209 & 15.205]

5.2.1. Limits

In any 100 KHz bandwidth outside the operating frequency band, the radio frequency power that is produced by modulation products of the spreading sequence, the information sequence and the carrier frequency shall be either at least 20 dB below that in any 100 KHz bandwidth within the band that contains the highest level of the desired power or shall not exceed the general levels specified in @ 15.209(a), which lesser attenuation.

All other emissions inside restricted bands specified in @ 15.205(a) shall not exceed the general radiated emission limits specified in @ 15.209(a)

Remarks:

- Applies to harmonics/spurious emissions that fall in the restricted bands listed in Section 15.205. The maximum permitted average field strength is listed in Section 15.209.
- @ **FCC CFR 47, Para. 15.237(c)** - The emission limits as specified above are based on measurement instrument employing an average detector. The provisions in @15.35 for limiting peak emissions apply.

FCC 47 CFR § 15.205(a) - Restricted Frequency Bands

MHz	MHz	MHz	GHz
0.090 - 0.110	162.0125 - 167.17	2310 - 2390	9.3 - 9.5
0.49 - 0.51	167.72 - 173.2	2483.5 - 2500	10.6 - 12.7
2.1735 - 2.1905	240 - 285	2655 - 2900	13.25 - 13.4
8.362 - 8.366	322 - 335.4	3260 - 3267	14.47 - 14.5
13.36 - 13.41	399.9 - 410	3332 - 3339	14.35 - 16.2
25.5 - 25.67	608 - 614	3345.8 - 3358	17.7 - 21.4
37.5 - 38.25	960 - 1240	3600 - 4400	22.01 - 23.12
73 - 75.4	1300 - 1427	4500 - 5250	23.6 - 24.0
108 - 121.94	1435 - 1626.5	5350 - 5460	31.2 - 31.8
123 - 138	1660 - 1710	7250 - 7750	36.43 - 36.5
149.9 - 150.05	1718.8 - 1722.2	8025 - 8500	Above 38.6
156.7 - 156.9	2200 - 2300	9000 - 9200	

**FCC 47 CFR § 15.209(a)
 -- Field Strength Limits within Restricted Frequency Bands --**

FREQUENCY (MHz)	FIELD STRENGTH LIMITS (microvolts/m)	DISTANCE (Meters)
0.009 - 0.490	2,400 / F (KHz)	300
0.490 - 1.705	24,000 / F (KHz)	30
1.705 - 30.0	30	30
30 - 88	100	3
88 - 216	150	3
216 - 960	200	3
Above 960	500	3

5.2.2. Method of Measurements

Refer to “FCC Measurement of Digital Transmission Systems Operating under Section 15.247 - March 23, 2005” and Ultratech Test Procedures, File # ULTR P003-2004 and ANSI C63.4 for measurement methods

Radiated emission test: Applies to harmonics/spurs that fall in the restricted bands listed in Section 15.205. The maximum permitted average field strength is listed in Section 15.209. A pre-amp (and possibly a high-pass filter) is necessary for this measurement. For measurements above 1 GHz, set RBW = 1MHz, VBW = 10 Hz, Sweep: Auto. If the emission is pulsed, modify the unit for continuous operation; use the settings shown above, then correct the reading by subtracting the peak-average correction factor, derived from the appropriate duty cycle calculation. See Section 15.35(b) and (c).

5.2.3. Test Equipment List

Test Instruments	Manufacturer	Model No.	Serial No.	Frequency Range
Spectrum Analyzer	Rohde & Schwarz	FSEK20/B4/B21	834157/005	9 kHz – 40 GHz
Microwave Amplifier	Hewlett Packard	HP 83017A		1 GHz to 26.5 GHz
Biconilog Antenna	EMCO	3143	1029	20 MHz to 2 GHz
Horn Antenna	EMCO	3155	9701-5061	1 GHz – 18 GHz
Horn Antenna	EMCO	3160-09	..	18 GHz – 26.5 GHz

5.2.4. Photographs Test Setup

Please refer to Photos # 1 to 6 in Annex 1 for details of test setup for radiated emissions measurements

5.2.5. Test Data

5.2.5.1. Band-edges Emissions (Radiated at 3 Meters)

Remark: For operation in 2412-2462 MHz, the radiated band-edge emissions were performed with 802.11g - 64QAM @ 54 Mb/s (worst case of power and modulation).

5.2.5.1.1. External Antennas

Conforms. Please see the following test data Plots 1(a)(b) – 18(a)(b) for detailed measurements of band-edge emissions.

Plot 1(a): Lower Band-Edge Transmitter Radiated Emissions @ 3 Meters, Horizontal Polarization

- Freq.: 2412 MHz, Power Setting: 19.5 dBm, Modulation: 802.11b – CCK @ 11Mb/s
- Trace 1: RBW= 1 MHz, VBW= 3 MHz
- Trace 2: RBW= 500 kHz, VBW= 1 MHz
- Trace 3: RBW= 1 MHz, VBW= 10 Hz

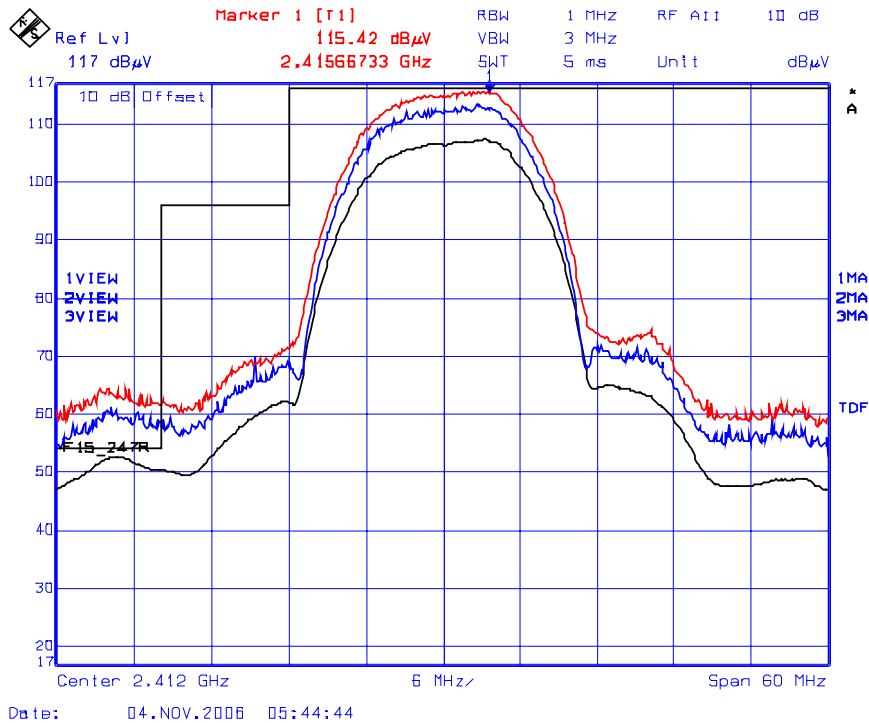

ULTRATECH GROUP OF LABS

3000 Bristol Circle, Oakville, Ontario, Canada L6H 6G4
Tel. #: 905-829-1570, Fax. #: 905-829-8050, Email: vic@ultratech-labs.com, Website: <http://www.ultratech-labs.com>

File #: CNI-080FCC15CE – 041207

Apr. 12, 2007

- All test results contained in this engineering test report are traceable to National Institute of Standards and Technology (NIST)

Plot 1(b): Lower Band-Edge Transmitter Radiated Emissions @ 3 Meters, Vertical Polarization

- Freq.: 2412 MHz, Power Setting: 19.5 dBm, Modulation: 802.11b – CCK @ 11Mb/s
- Trace 1: RBW= 1 MHz, VBW= 3 MHz
- Trace 2: RBW= 500 kHz, VBW= 1 MHz
- Trace 3: RBW= 1 MHz, VBW= 10 Hz

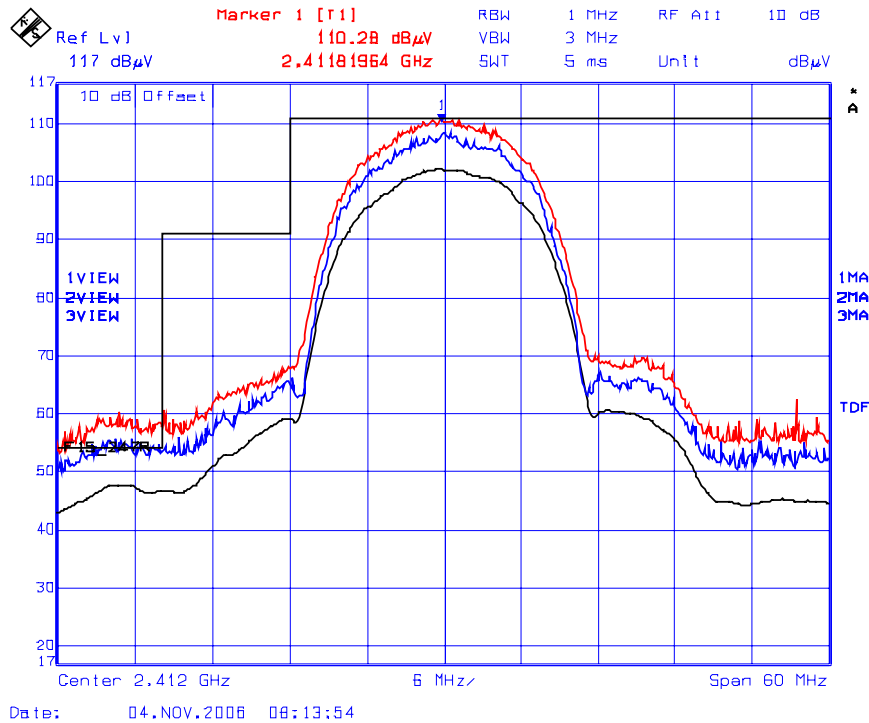

ULTRATECH GROUP OF LABS

3000 Bristol Circle, Oakville, Ontario, Canada L6H 6G4
Tel. #: 905-829-1570, Fax. #: 905-829-8050, Email: vic@ultratech-labs.com, Website: <http://www.ultratech-labs.com>

File #: CNI-080FCC15CE – 041207
Apr. 12, 2007

- All test results contained in this engineering test report are traceable to National Institute of Standards and Technology (NIST)

Plot 2(a): Inner Band-Edge Transmitter Radiated Emissions @ 3 Meters, Horizontal Polarization

- Freq.: 2417 MHz, Power Setting: 19.0 dBm, Modulation: 802.11b – CCK @ 11Mb/s
- Trace 1: RBW= 1 MHz, VBW= 3 MHz
- Trace 2: RBW= 500 kHz, VBW= 1 MHz
- Trace 3: RBW= 1 MHz, VBW= 10 Hz

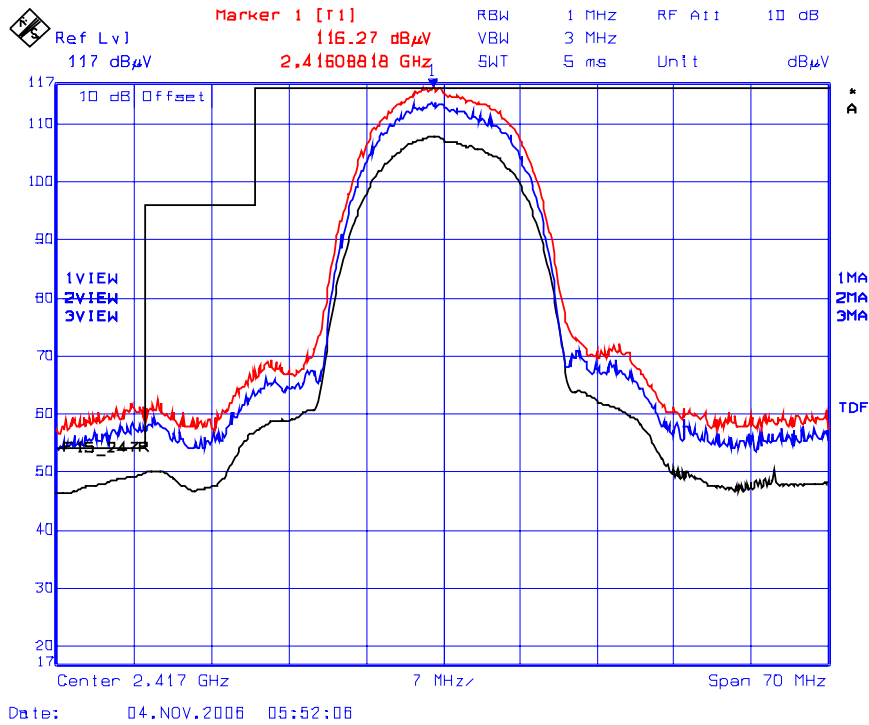

ULTRATECH GROUP OF LABS

3000 Bristol Circle, Oakville, Ontario, Canada L6H 6G4
Tel. #: 905-829-1570, Fax. #: 905-829-8050, Email: vic@ultratech-labs.com, Website: <http://www.ultratech-labs.com>

File #: CNI-080FCC15CE – 041207

Apr. 12, 2007

- All test results contained in this engineering test report are traceable to National Institute of Standards and Technology (NIST)

Plot 2(b): Inner Band-Edge Transmitter Radiated Emissions @ 3 Meters, Vertical Polarization

- Freq.: 2417 MHz, Power Setting: 19.0 dBm, Modulation: 802.11b – CCK @ 11Mb/s
- Trace 1: RBW= 1 MHz, VBW= 3 MHz
- Trace 2: RBW= 500 kHz, VBW= 1 MHz
- Trace 3: RBW= 1 MHz, VBW= 10 Hz

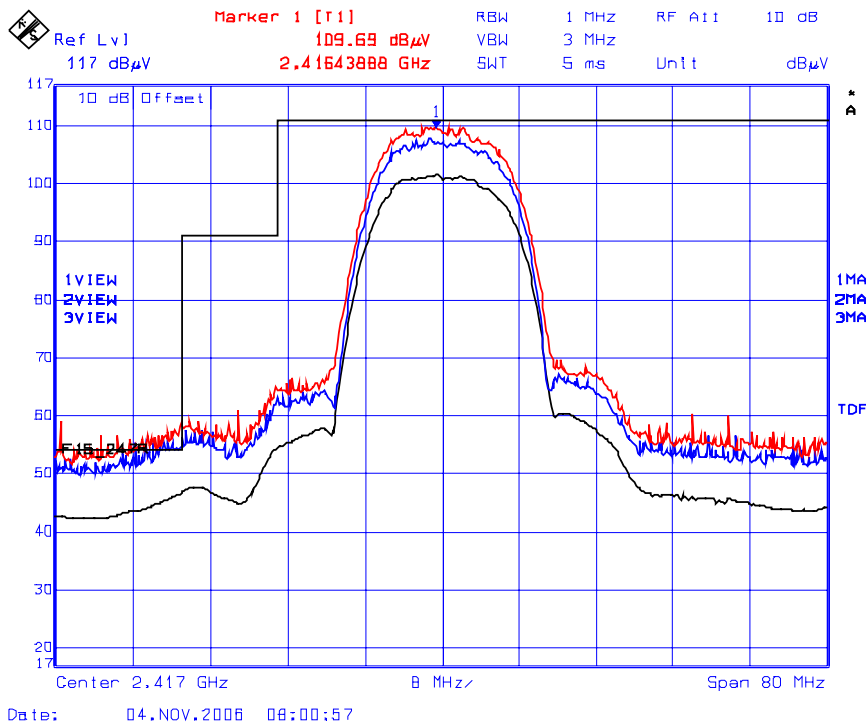

ULTRATECH GROUP OF LABS

3000 Bristol Circle, Oakville, Ontario, Canada L6H 6G4
Tel. #: 905-829-1570, Fax. #: 905-829-8050, Email: vic@ultratech-labs.com, Website: <http://www.ultratech-labs.com>

File #: CNI-080FCC15CE – 041207

Apr. 12, 2007

- All test results contained in this engineering test report are traceable to National Institute of Standards and Technology (NIST)

Plot 3(a): Inner Band-Edge Transmitter Radiated Emissions @ 3 Meters, Horizontal Polarization

- Freq.: 2422 MHz, Power Setting: 20 dBm, Modulation: 802.11b – CCK @ 11Mb/s
- Trace 1: RBW= 1 MHz, VBW= 3 MHz
- Trace 2: RBW= 500 kHz, VBW= 1 MHz
- Trace 3: RBW= 1 MHz, VBW= 10 Hz

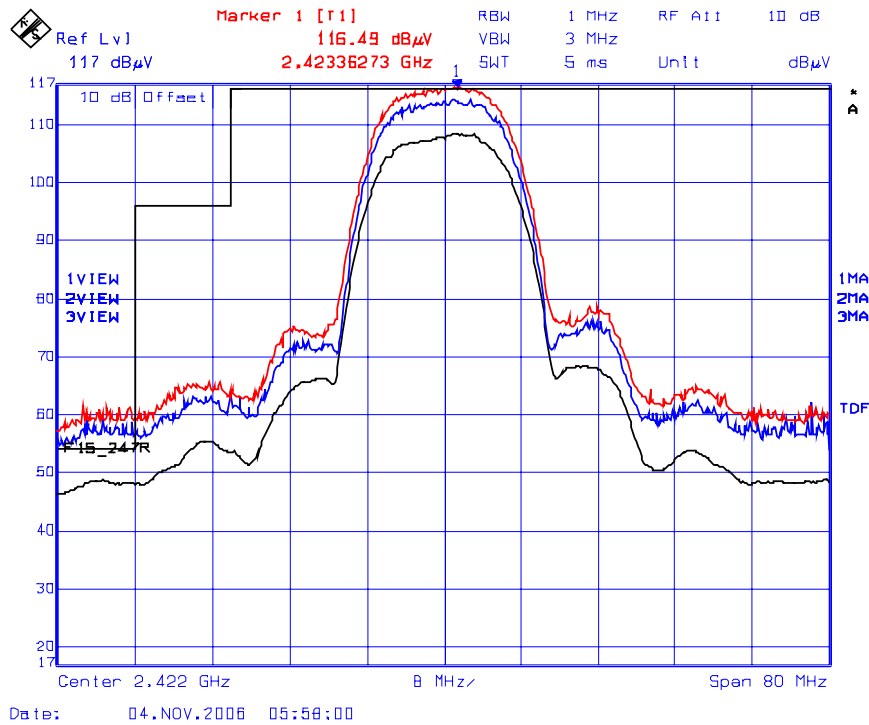

Plot 3(b): Inner Band-Edge Transmitter Radiated Emissions @ 3 Meters, Vertical Polarization

- Freq.: 2422 MHz, Power Setting: 20 dBm, Modulation: 802.11b – CCK @ 11Mb/s
- Trace 1: RBW= 1 MHz, VBW= 3 MHz
- Trace 2: RBW= 500 kHz, VBW= 1 MHz
- Trace 3: RBW= 1 MHz, VBW= 10 Hz

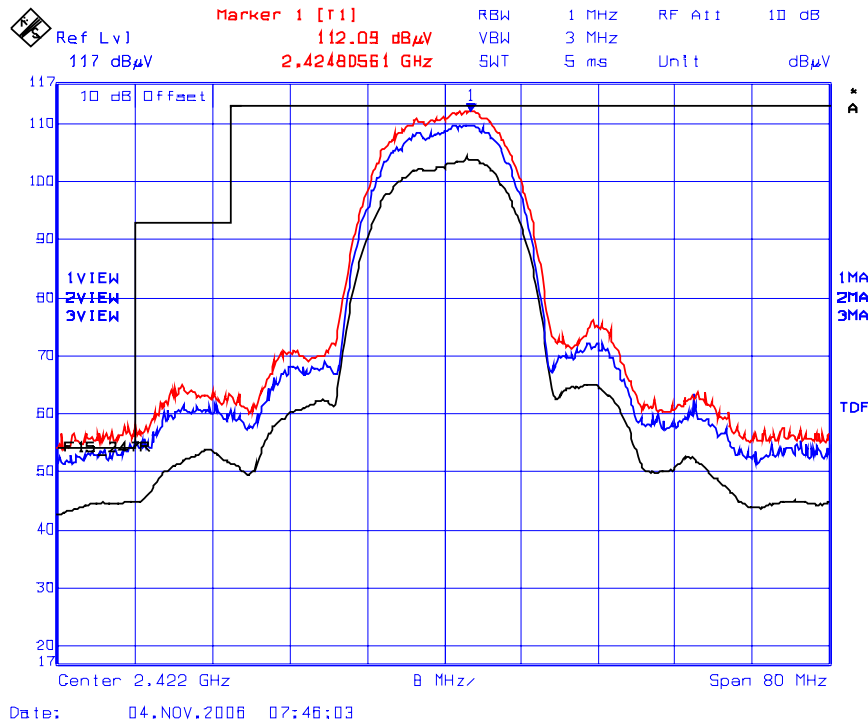

Plot 4 (a): Inner Band-Edge Transmitter Radiated Emissions @ 3 Meters, Horizontal Polarization

- Freq.: 2457 MHz, Power Setting: 20 dBm, Modulation: 802.11b – CCK @ 11Mb/s
- Trace 1: RBW= 1 MHz, VBW= 3 MHz
- Trace 2: RBW= 500 kHz, VBW= 1 MHz
- Trace 3: RBW= 1 MHz, VBW= 10 Hz

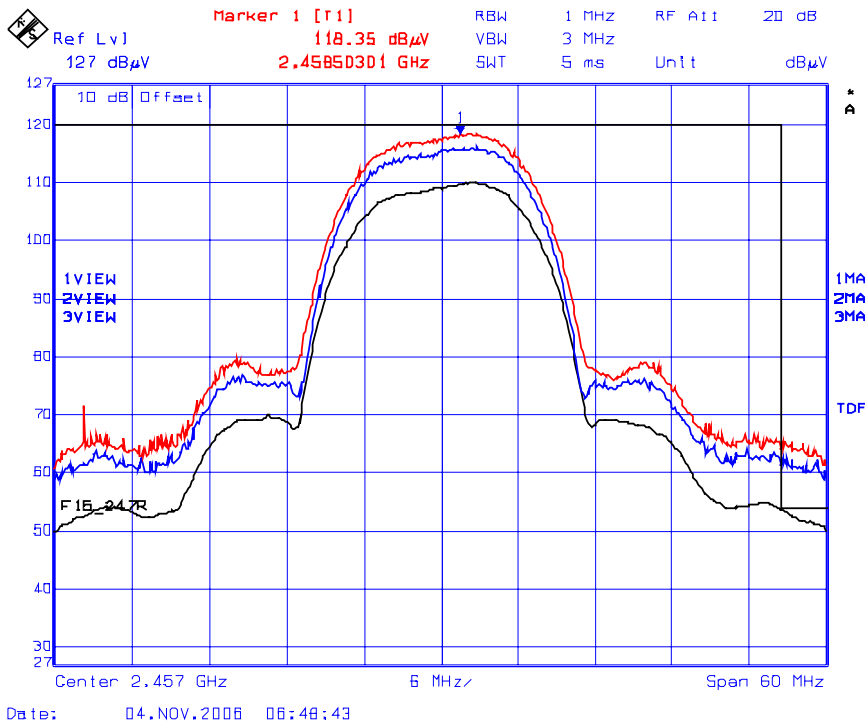

Plot 4(b): Inner Band-Edge Transmitter Radiated Emissions @ 3 Meters, Vertical Polarization

- Freq.: 2457 MHz, Power Setting: 20 dBm, Modulation: 802.11b – CCK @ 11Mb/s
- Trace 1: RBW= 1 MHz, VBW= 3 MHz
- Trace 2: RBW= 500 kHz, VBW= 1 MHz
- Trace 3: RBW= 1 MHz, VBW= 10 Hz

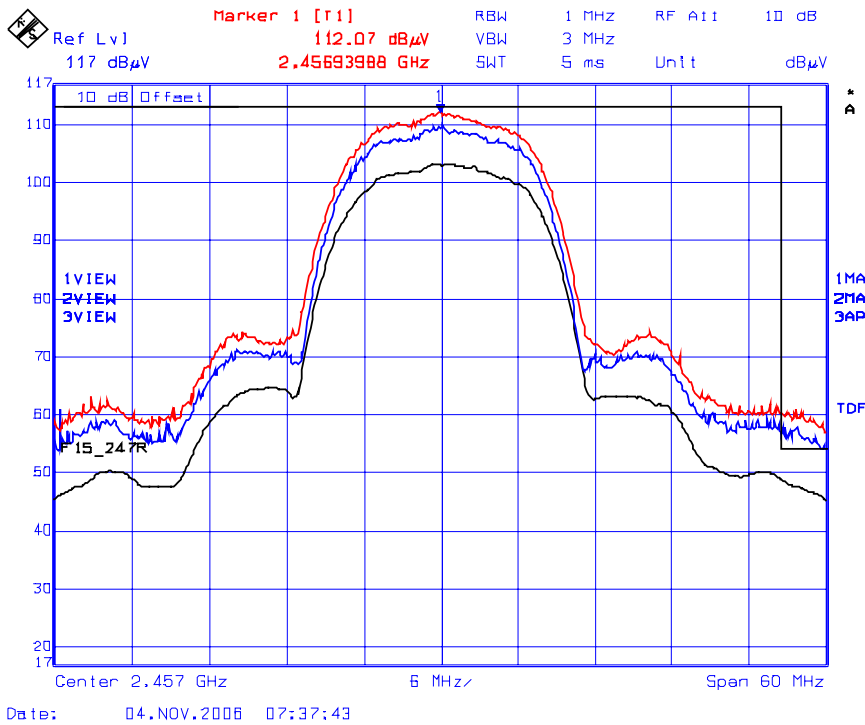

Plot 5(a): Upper Band-Edge Transmitter Radiated Emissions @ 3 Meters, Horizontal Polarization

- Freq.: 2462 MHz, Power Setting: 19.5 dBm, Modulation: 802.11b – CCK @ 11Mb/s
- **Trace 1:** RBW= 1 MHz, VBW= 3 MHz
- **Trace 2:** RBW= 500 kHz, VBW= 1 MHz
- **Trace 3:** RBW= 1 MHz, VBW= 10 Hz

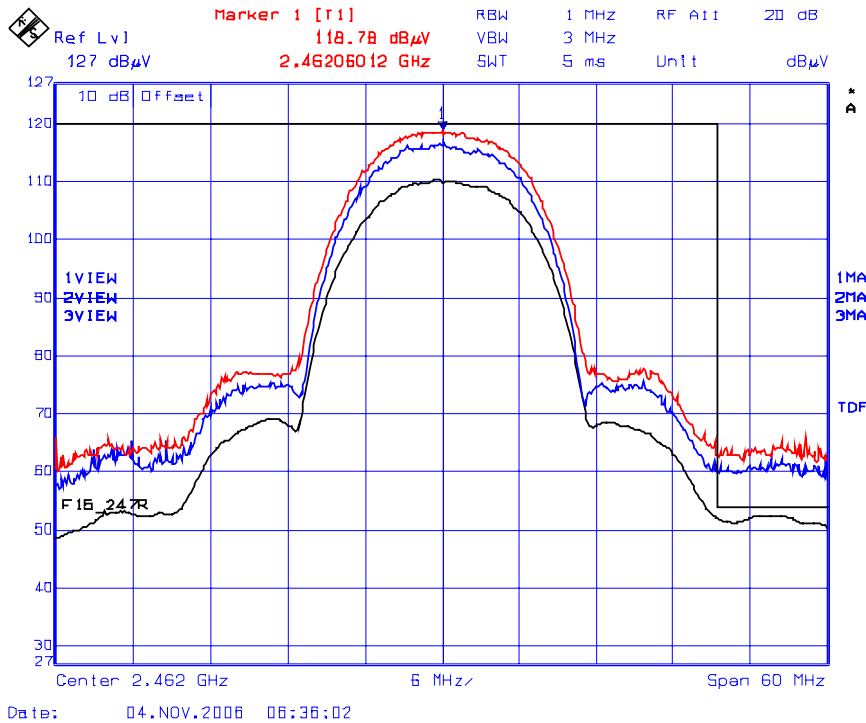

Plot 5(b): Upper Band-Edge Transmitter Radiated Emissions @ 3 Meters, Vertical Polarization

- Freq.: 2462 MHz, Power Setting: 19.5 dBm, Modulation: 802.11b – CCK @ 11Mb/s
- Trace 1: RBW= 1 MHz, VBW= 3 MHz
- Trace 2: RBW= 500 kHz, VBW= 1 MHz
- Trace 3: RBW= 1 MHz, VBW= 10 Hz

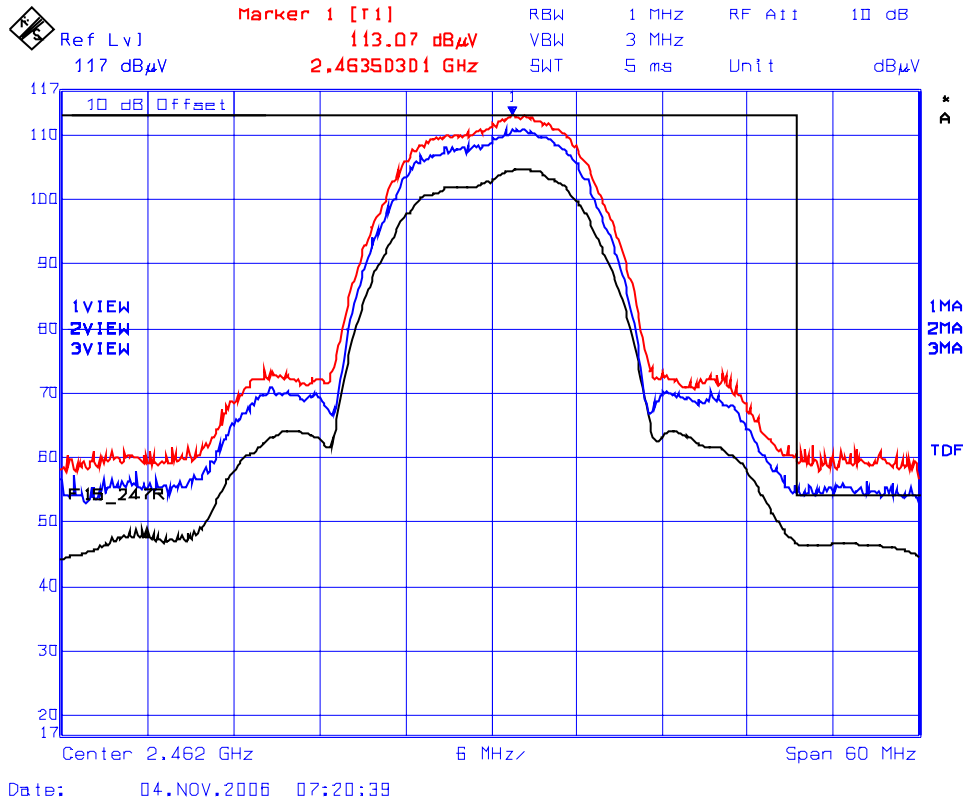

Plot 6(a): Lower Band-Edge Transmitter Radiated Emissions @ 3 Meters, Horizontal Polarization

- Freq.: 2412 MHz, Power Setting: 15 dBm, Modulation: 802.11g - 64QAM @ 54 Mbps
- Trace 1: RBW= 1 MHz, VBW= 3 MHz
- Trace 2: RBW= 500 kHz, VBW= 1 MHz, Delta (Peak to Band-Edge): 42.44 dB
- Trace 3: RBW= 1 MHz, VBW= 10 Hz
- Band-Edge Level at 2389 MHz: $115.21\text{dBuV/m} - 42.44\text{ dB} = 72.77\text{dBuV/m} < \text{Limit of } 74\text{dBuV/m}$

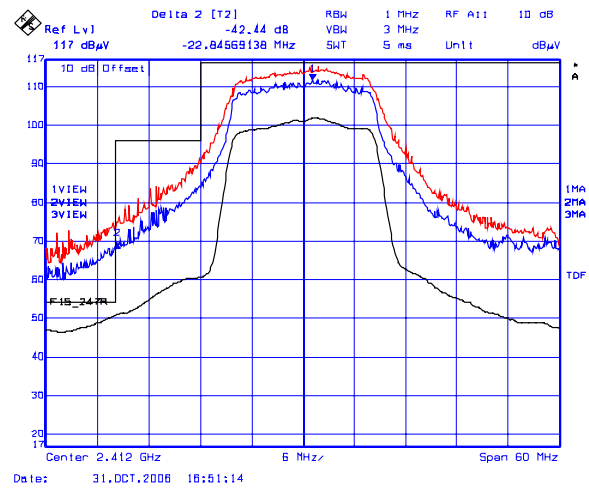
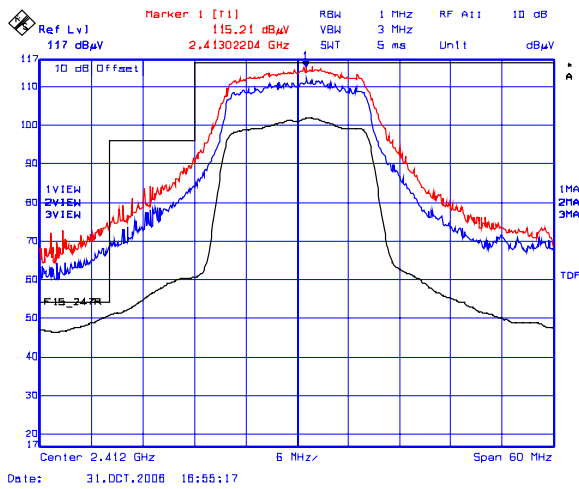

Plot 6(b): Lower Band-Edge Transmitter Radiated Emissions @ 3 Meters, Vertical Polarization

- Freq.: 2412 MHz, Power Setting: 15 dBm, Modulation: 802.11g - 64QAM @ 54 Mbps
- Trace 1: RBW= 1 MHz, VBW= 3 MHz
- Trace 2: RBW= 500 kHz, VBW= 1 MHz
- Trace 3: RBW= 1 MHz, VBW= 10 Hz

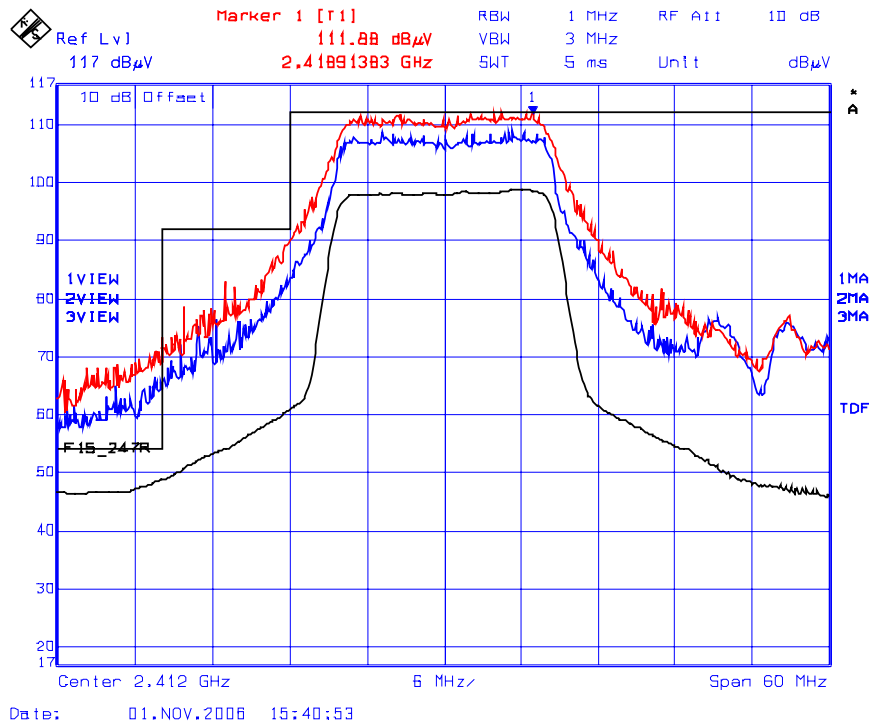

Plot 7(a): Inner Band-Edge Transmitter Radiated Emissions @ 3 Meters, Horizontal Polarization

- Freq.: 2417 MHz, Power Setting: 17 dBm, Modulation: 802.11g - 64QAM @ 54 Mbps
- Trace 1: RBW= 1 MHz, VBW= 3 MHz
- Trace 2: RBW= 500 kHz, VBW= 1 MHz, Delta (Peak to Band-Edge): 43.98 dB
- Trace 3: RBW= 1 MHz, VBW= 10 Hz
- Band-Edge Level at 2389 MHz: 117.40dBuV/m – 43.98 dB= 73.42dBuV/m (Limit 74dBu/m)

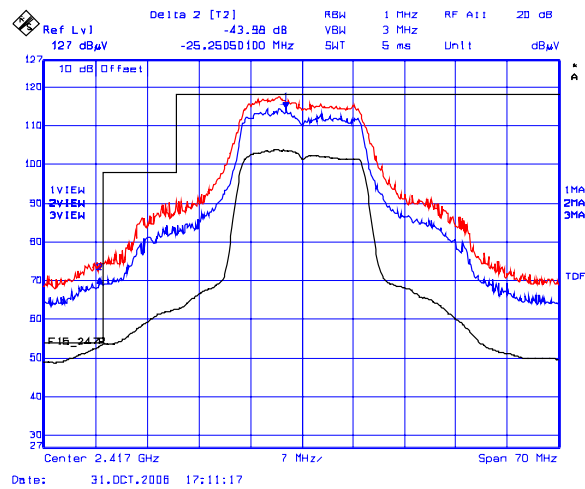
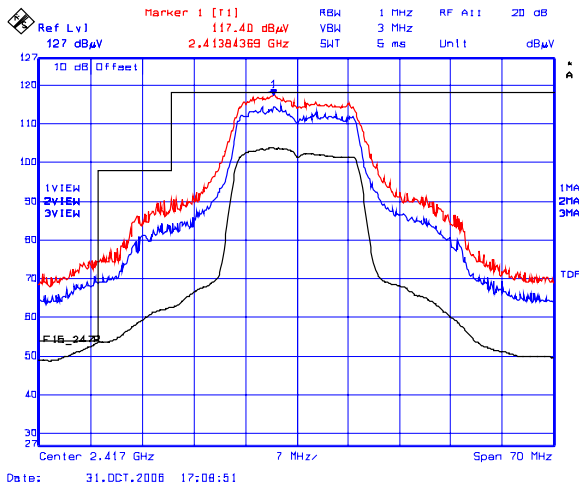

Plot 7(b): Inner Band-Edge Transmitter Radiated Emissions @ 3 Meters, Vertical Polarization

- Freq.: 2417 MHz, Power Setting: 20 dBm, Modulation: 802.11g - 64QAM @ 54 Mbps
- Trace 1: RBW= 1 MHz, VBW= 3 MHz
- Trace 2: RBW= 500 kHz, VBW= 1 MHz
- Trace 3: RBW= 1 MHz, VBW= 10 Hz

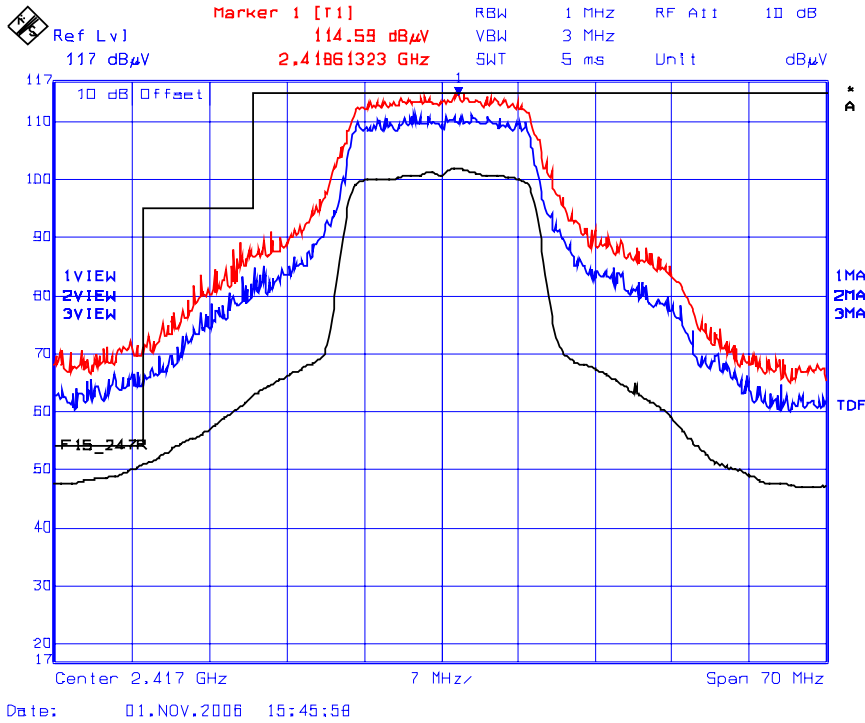

Plot 8(a): Inner Band-Edge Transmitter Radiated Emissions @ 3 Meters, Horizontal Polarization

- Freq.: 2422 MHz, Power Setting: 18.5 dBm, Modulation: 802.11g - 64QAM @ 54 Mbps
- Trace 1: RBW= 1 MHz, VBW= 3 MHz
- Trace 2: RBW= 500 kHz, VBW= 1 MHz, Delta (Peak to Band-Edge): 43.82 dB
- Trace 3: RBW= 1 MHz, VBW= 10 Hz
- Band-Edge Level at 2389 MHz: 117.72dBuV/m – 43.82 dB= 73.90dBuV/m (Limit 74dBu/m)

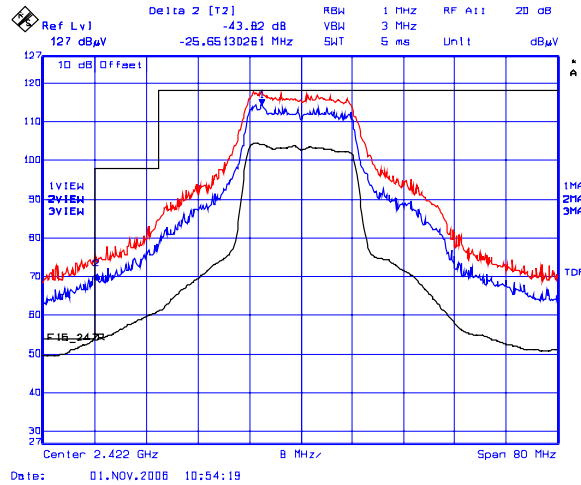
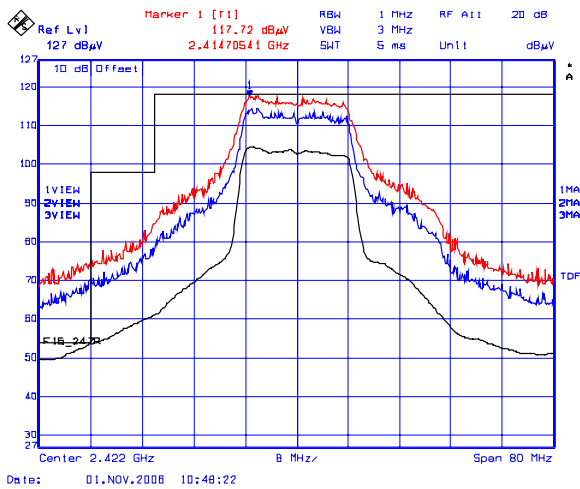

ULTRATECH GROUP OF LABS

3000 Bristol Circle, Oakville, Ontario, Canada L6H 6G4
Tel. #: 905-829-1570, Fax. #: 905-829-8050, Email: vic@ultratech-labs.com, Website: <http://www.ultratech-labs.com>

File #: CNI-080FCC15CE – 041207
Apr. 12, 2007

- All test results contained in this engineering test report are traceable to National Institute of Standards and Technology (NIST)

Plot 8(b): Inner Band-Edge Transmitter Radiated Emissions @ 3 Meters, Vertical Polarization

- Freq.: 2422 MHz, Power Setting: 18.5 dBm, Modulation: 802.11g - 64QAM @ 54 Mbps
- Trace 1: RBW= 1 MHz, VBW= 3 MHz
- Trace 2: RBW= 500 kHz, VBW= 1 MHz
- Trace 3: RBW= 1 MHz, VBW= 10 Hz

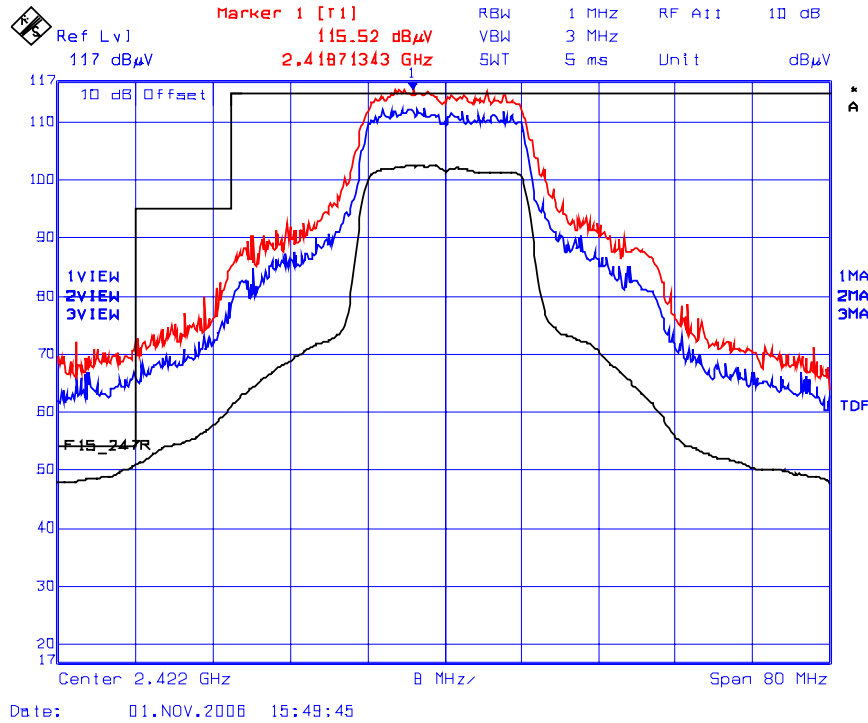

Plot 9(a): Inner Band-Edge Transmitter Radiated Emissions @ 3 Meters, Horizontal Polarization

- Freq.: 2427 MHz, Power Setting: 19.0 dBm, Modulation: 802.11g - 64QAM @ 54 Mbps
- Trace 1: RBW= 1 MHz, VBW= 3 MHz
- Trace 2: RBW= 500 kHz, VBW= 1 MHz, Delta (Peak to Band-Edge): 45.38 dB
- Trace 3: RBW= 1 MHz, VBW= 10 Hz
- Band-Edge Level at 2389 MHz: 117.15dBuV/m – 45.38 dB= 71.77dBuV/m (Limit 74dBu/m)

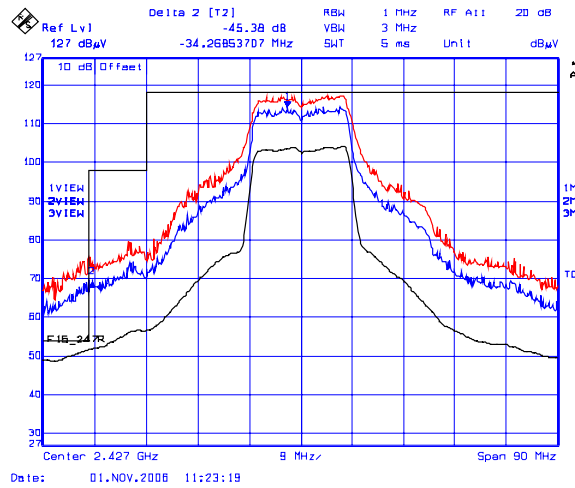
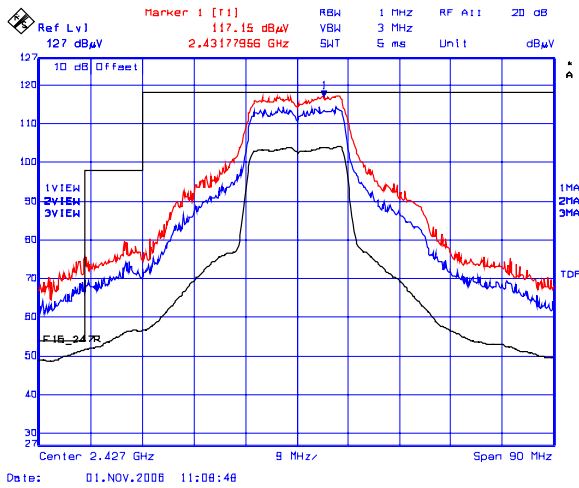

ULTRATECH GROUP OF LABS

3000 Bristol Circle, Oakville, Ontario, Canada L6H 6G4
Tel. #: 905-829-1570, Fax. #: 905-829-8050, Email: vic@ultratech-labs.com, Website: <http://www.ultratech-labs.com>

File #: CNI-080FCC15CE – 041207

Apr. 12, 2007

- All test results contained in this engineering test report are traceable to National Institute of Standards and Technology (NIST)

Plot 9(b): Inner Band-Edge Transmitter Radiated Emissions @ 3 Meters, Vertical Polarization

- Freq.: 2427 MHz, Power Setting: 19.0 dBm, Modulation: 802.11g - 64QAM @ 54 Mbps
- Trace 1: RBW= 1 MHz, VBW= 3 MHz
- Trace 2: RBW= 500 kHz, VBW= 1 MHz
- Trace 3: RBW= 1 MHz, VBW= 10 Hz

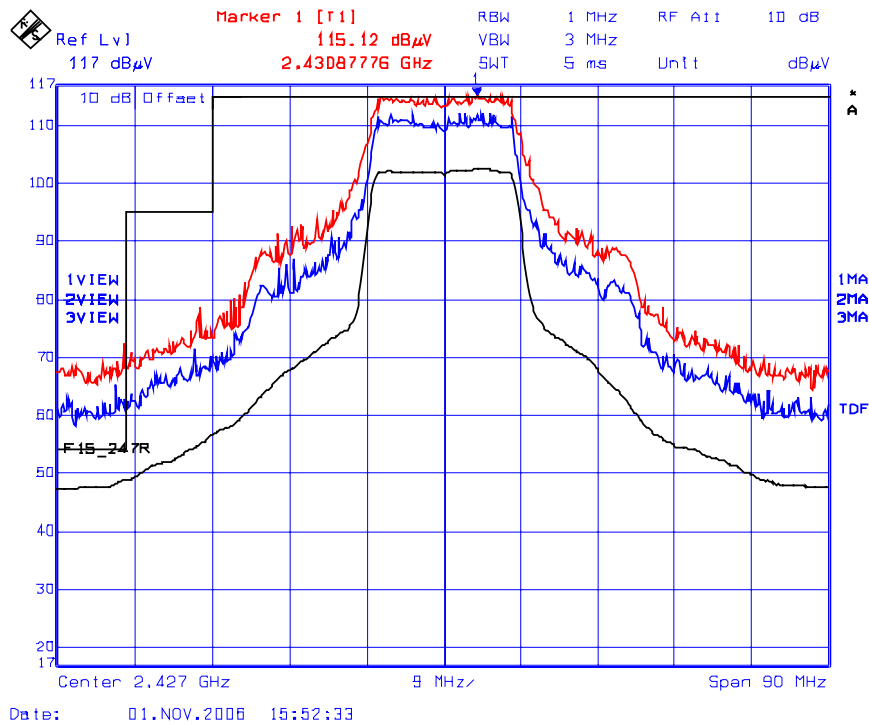

ULTRATECH GROUP OF LABS

3000 Bristol Circle, Oakville, Ontario, Canada L6H 6G4
Tel. #: 905-829-1570, Fax. #: 905-829-8050, Email: vic@ultratech-labs.com, Website: <http://www.ultratech-labs.com>

File #: CNI-080FCC15CE – 041207

Apr. 12, 2007

- All test results contained in this engineering test report are traceable to National Institute of Standards and Technology (NIST)

Plot 10(a): Inner Band-Edge Transmitter Radiated Emissions @ 3 Meters, Horizontal Polarization

- Freq.: 2432 MHz, Power Setting: 20 dBm, Modulation: 802.11g - 64QAM @ 54 Mbps
- **Trace 1:** RBW= 1 MHz, VBW= 3 MHz
- **Trace 2:** RBW= 500 kHz, VBW= 1 MHz, Delta (Peak to Band-Edge): 46.96 dB
- **Trace 3:** RBW= 1 MHz, VBW= 10 Hz
- Band-Edge Level at 2389 MHz: 118.72dBuV/m – 46.96 dB= 71.76dBuV/m (Limit 74dBu/m)

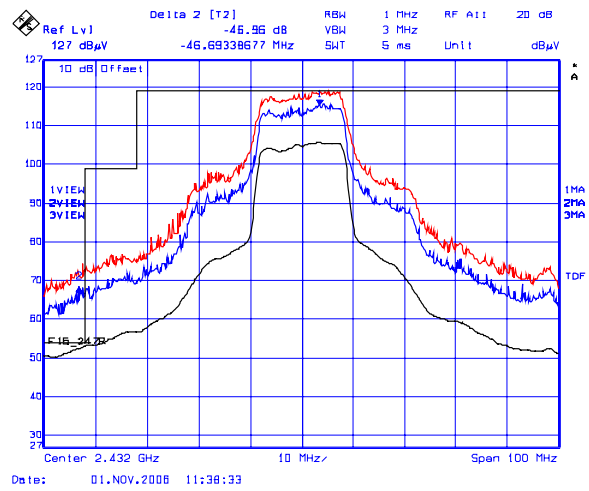
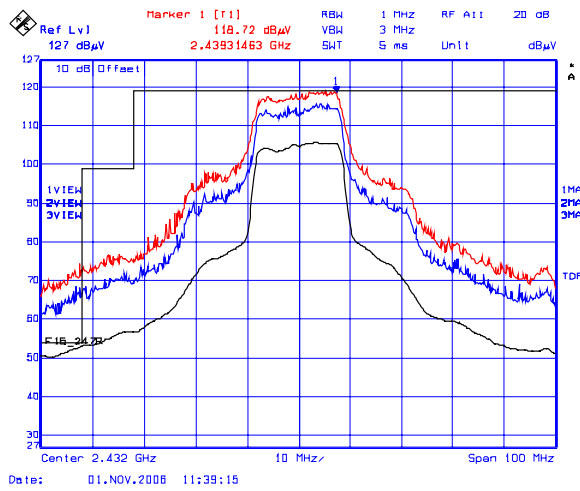

Plot 10(b): Inner Band-Edge Transmitter Radiated Emissions @ 3 Meters, Vertical Polarization

- Freq.: 2432 MHz, Power Setting: 20 dBm, Modulation: 802.11g - 64QAM @ 54 Mbps
- Trace 1: RBW= 1 MHz, VBW= 3 MHz
- Trace 2: RBW= 500 kHz, VBW= 1 MHz
- Trace 3: RBW= 1 MHz, VBW= 10 Hz

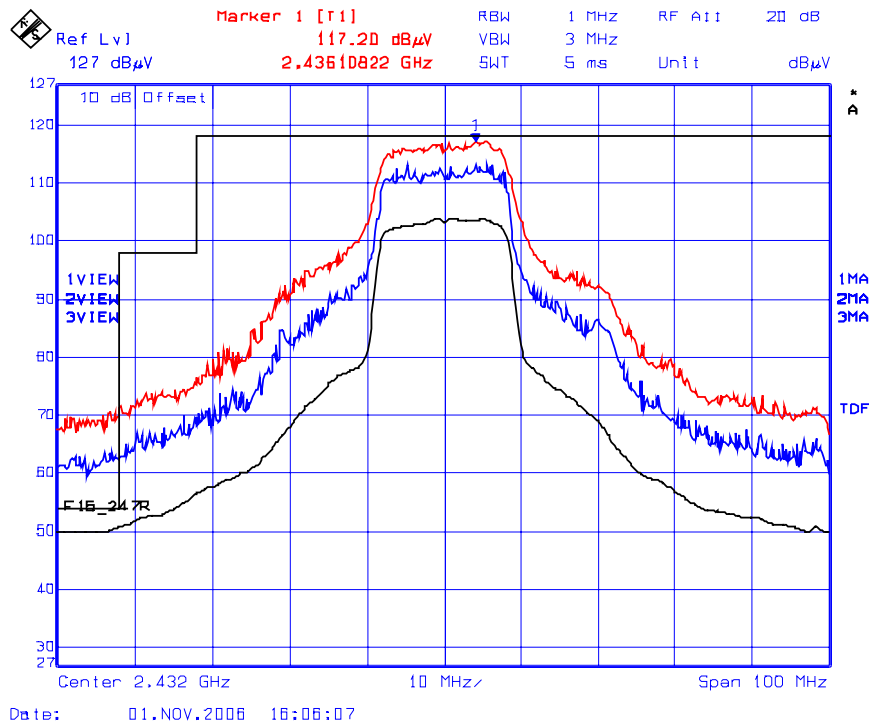

Plot 11(a): Inner Band-Edge Transmitter Radiated Emissions @ 3 Meters, Horizontal Polarization

- Freq.: 2437 MHz, Power Setting: 20 dBm, Modulation: 802.11g - 64QAM @ 54 Mbps
- Trace 1: RBW= 1 MHz, VBW= 3 MHz
- Trace 2: RBW= 500 kHz, VBW= 1 MHz
- Trace 3: RBW= 1 MHz, VBW= 10 Hz

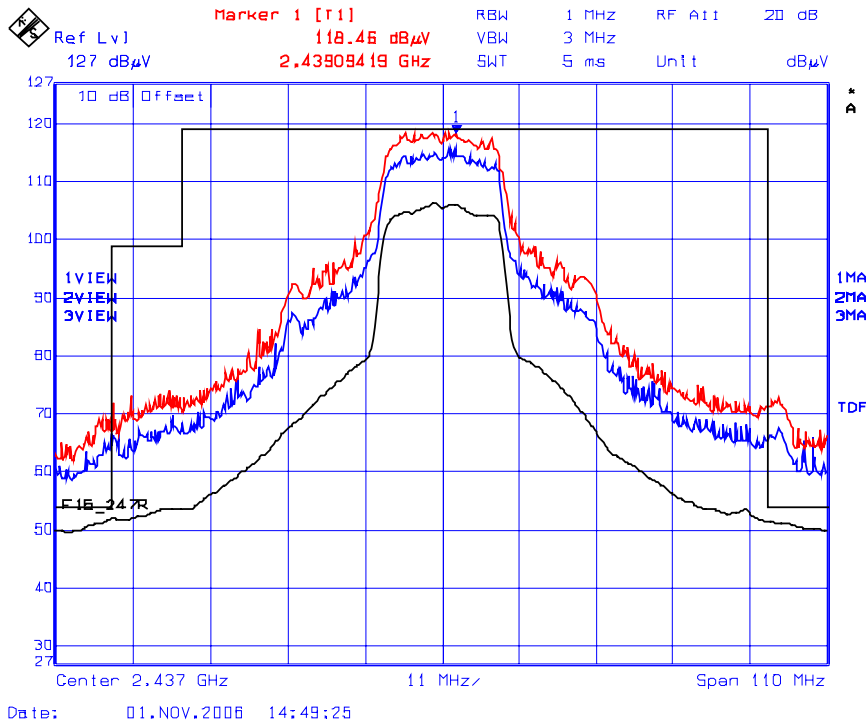

Plot 11(b): Inner Band-Edge Transmitter Radiated Emissions @ 3 Meters, Vertical Polarization

- Freq.: 2437 MHz, Power Setting: 20 dBm, Modulation: 802.11g - 64QAM @ 54 Mbps
- Trace 1: RBW= 1 MHz, VBW= 3 MHz
- Trace 2: RBW= 500 kHz, VBW= 1 MHz
- Trace 3: RBW= 1 MHz, VBW= 10 Hz

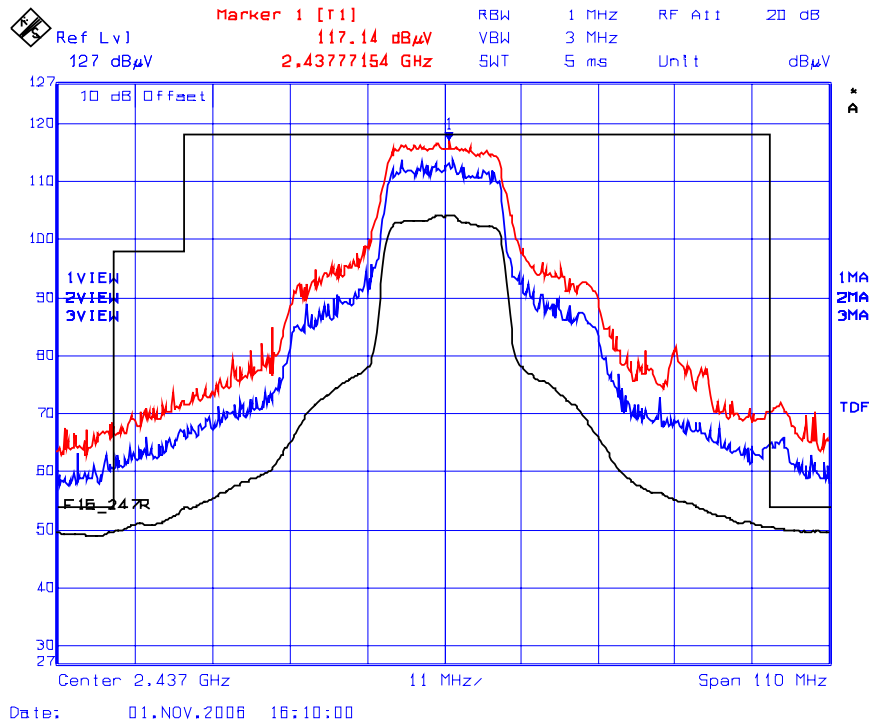

Plot 12(a): Inner Band-Edge Transmitter Radiated Emissions @ 3 Meters, Horizontal Polarization

- Freq.: 2442 MHz, Power Setting: 20 dBm, Modulation: 802.11g - 64QAM @ 54 Mbps
- Trace 1: RBW= 1 MHz, VBW= 3 MHz
- Trace 2: RBW= 500 kHz, VBW= 1 MHz, Delta (Peak to Band-Edge): 48.87 dB
- Trace 3: RBW= 1 MHz, VBW= 10 Hz
- Band-Edge Level at 2483.5 MHz: 118.49dBuV/m – 48.87 dB= 69.62dBuV/m (Limit 74dBuV/m)

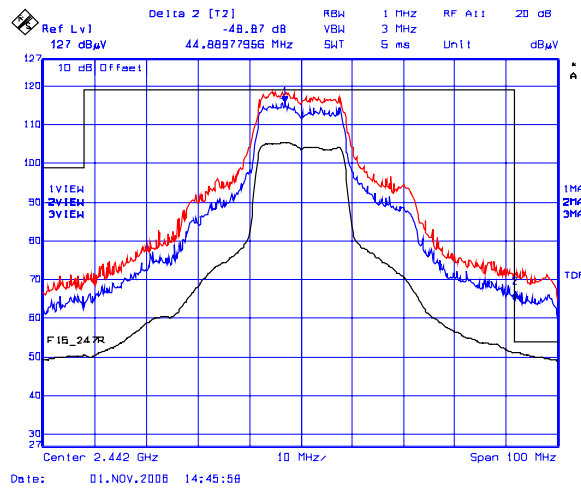
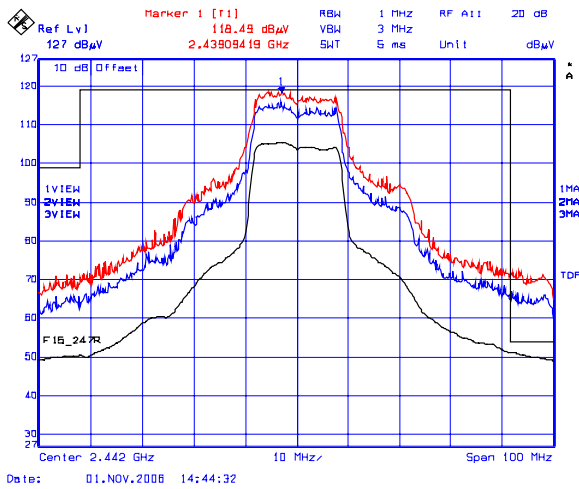

Plot 12(b): Inner Band-Edge Transmitter Radiated Emissions @ 3 Meters, Vertical Polarization

- Freq.: 2442 MHz, Power Setting: 20 dBm, Modulation: 802.11g - 64QAM @ 54 Mbps
- **Trace 1:** RBW= 1 MHz, VBW= 3 MHz
- **Trace 2:** RBW= 500 kHz, VBW= 1 MHz
- **Trace 3:** RBW= 1 MHz, VBW= 10 Hz

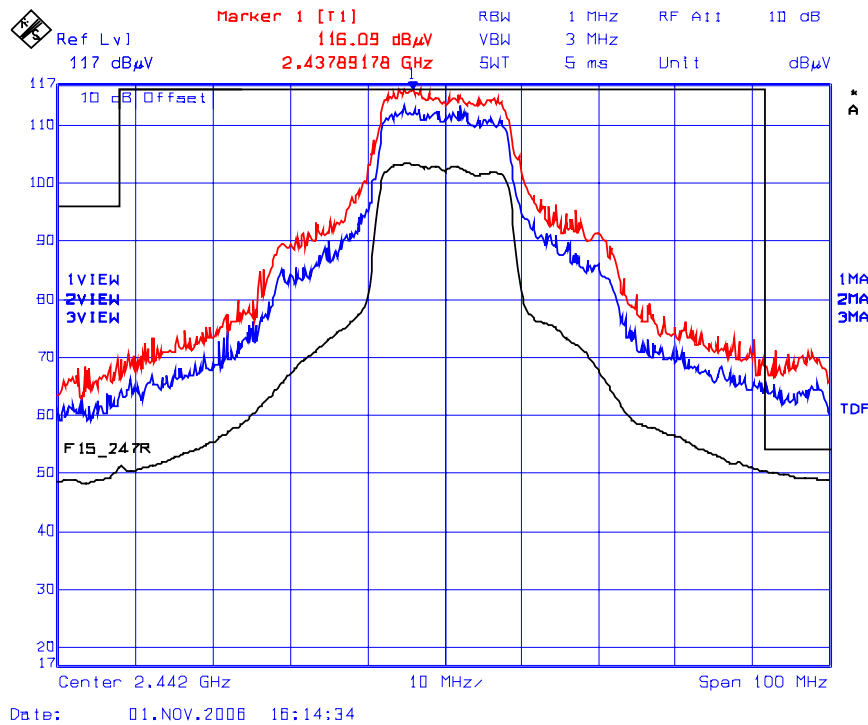

Plot 13(a): Inner Band-Edge Transmitter Radiated Emissions @ 3 Meters, Horizontal Polarization

- Freq.: 2447 MHz, Power Setting: 19.5 dBm, Modulation: 802.11g - 64QAM @ 54 Mbps
- Trace 1: RBW= 1 MHz, VBW= 3 MHz
- Trace 2: RBW= 500 kHz, VBW= 1 MHz, Delta (Peak to Band-Edge): 46.10 dB
- Trace 3: RBW= 1 MHz, VBW= 10 Hz
- Band-Edge Level at 2483.5 MHz: 118.29dBuV/m – 46.10 dB= 72.19dBuV/m (Limit 74dBuV/m)

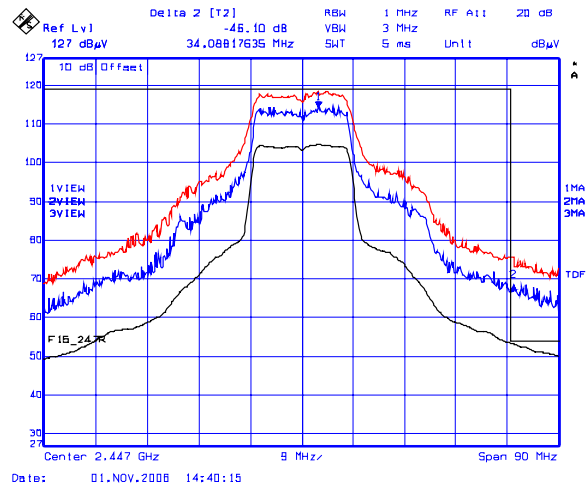
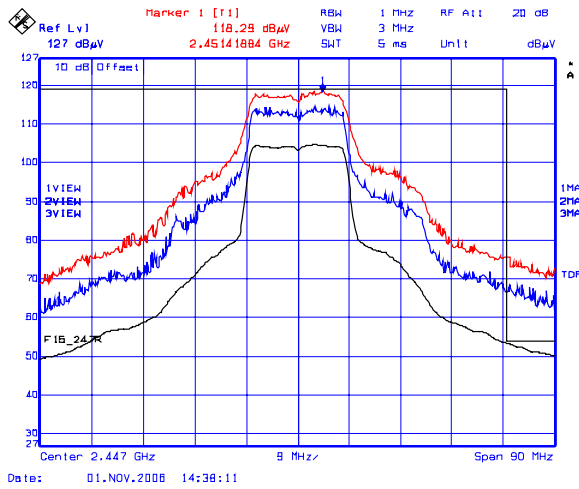

Plot 13(b): Inner Band-Edge Transmitter Radiated Emissions @ 3 Meters, Vertical Polarization

- Freq.: 2447 MHz, Power Setting: 19.5 dBm, Modulation: 802.11g - 64QAM @ 54 Mbps
- Trace 1: RBW= 1 MHz, VBW= 3 MHz
- Trace 2: RBW= 500 kHz, VBW= 1 MHz
- Trace 3: RBW= 1 MHz, VBW= 10 Hz

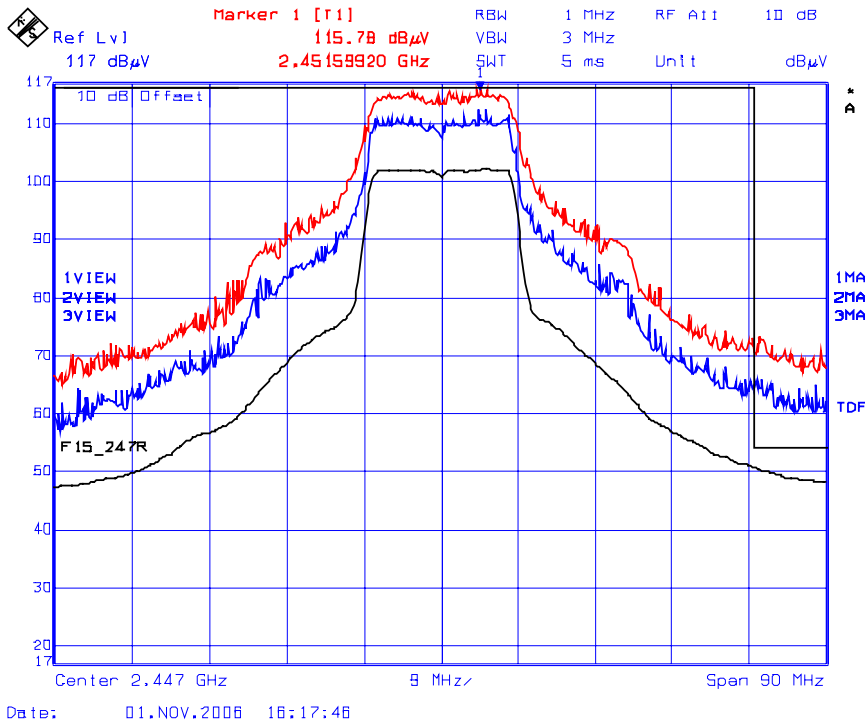

ULTRATECH GROUP OF LABS

3000 Bristol Circle, Oakville, Ontario, Canada L6H 6G4
Tel. #: 905-829-1570, Fax. #: 905-829-8050, Email: vic@ultratech-labs.com, Website: <http://www.ultratech-labs.com>

File #: CNI-080FCC15CE – 041207

Apr. 12, 2007

- All test results contained in this engineering test report are traceable to National Institute of Standards and Technology (NIST)

Plot 14(a): Inner Band-Edge Transmitter Radiated Emissions @ 3 Meters, Horizontal Polarization

- Freq.: 2452 MHz, Power Setting: 19.0 dBm, Modulation: 802.11g - 64QAM @ 54 Mbps
- Trace 1: RBW= 1 MHz, VBW= 3 MHz
- Trace 2: RBW= 500 kHz, VBW= 1 MHz, Delta (Peak to Band-Edge): 45.47 dB
- Trace 3: RBW= 1 MHz, VBW= 10 Hz
- Band-Edge Level at 2483.5 MHz: 117.11dBuV/m – 45.47 dB= 71.64dBuV/m (Limit 74dBuV/m)

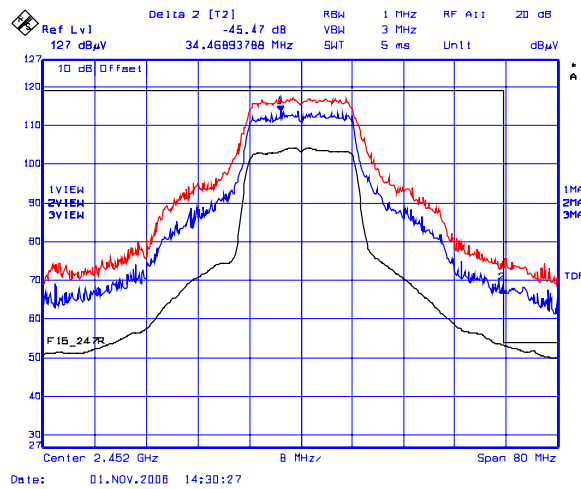
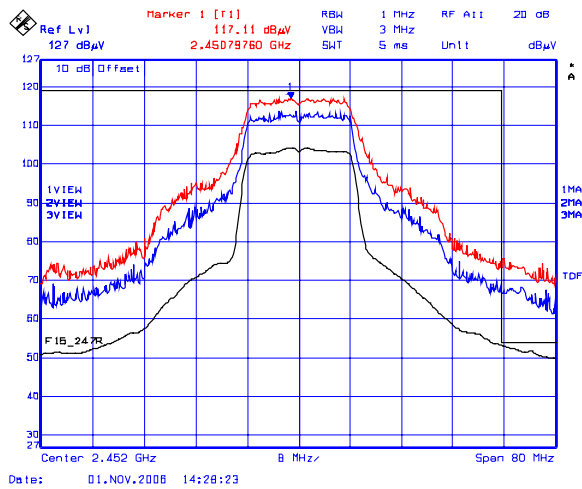

Plot 14(b): Inner Band-Edge Transmitter Radiated Emissions @ 3 Meters, Vertical Polarization

- Freq.: 2452 MHz, Power Setting: 19.0 dBm, Modulation: 802.11g - 64QAM @ 54 Mbps
- Trace 1: RBW= 1 MHz, VBW= 3 MHz
- Trace 2: RBW= 500 kHz, VBW= 1 MHz
- Trace 3: RBW= 1 MHz, VBW= 10 Hz

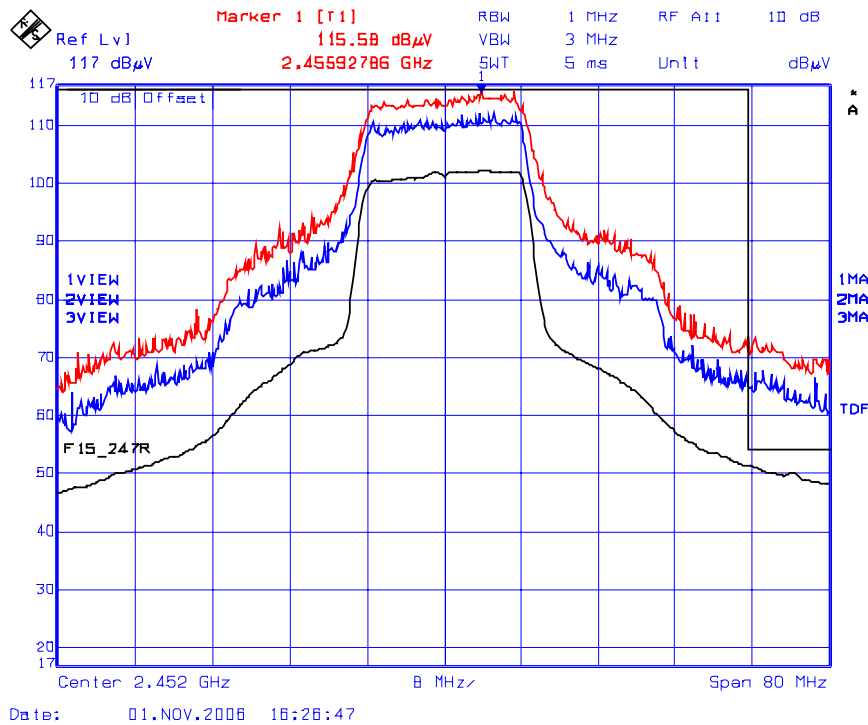

Plot 15(a): Inner Band-Edge Transmitter Radiated Emissions @ 3 Meters, Horizontal Polarization

- Freq.: 2457 MHz, Power Setting: 18.0 dBm, Modulation: 802.11g - 64QAM @ 54 Mbps
- Trace 1: RBW= 1 MHz, VBW= 3 MHz
- Trace 2: RBW= 500 kHz, VBW= 1 MHz, Delta (Peak to Band-Edge): 43.96 dB
- Trace 3: RBW= 1 MHz, VBW= 10 Hz
- Band-Edge Level at 2483.5 MHz: 117.18dBuV/m – 43.96 dB= 73.22dBuV/m (Limit 74dBu/m)

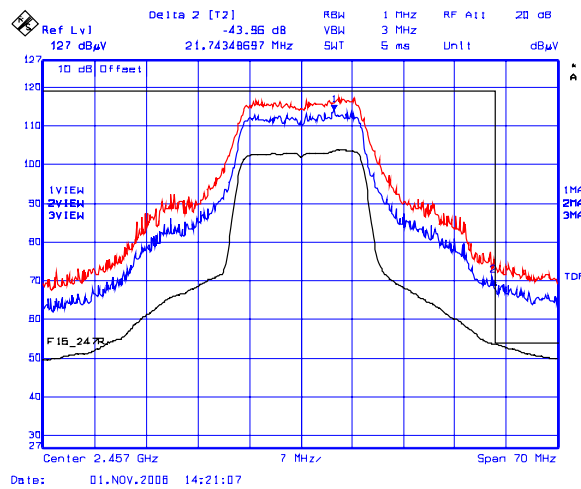
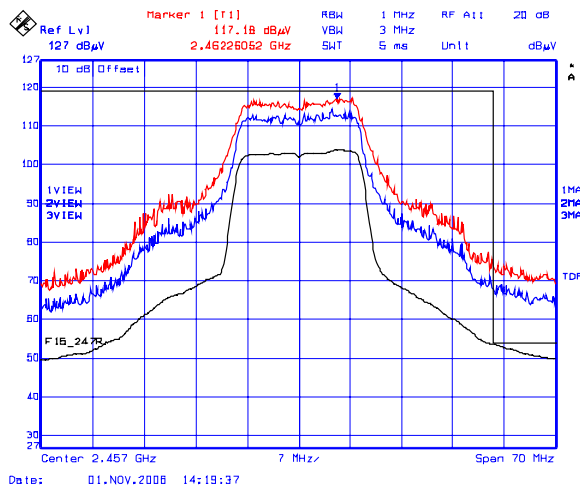

Plot 15(b): Inner Band-Edge Transmitter Radiated Emissions @ 3 Meters, Vertical Polarization

- Freq.: 2457 MHz, Power Setting: 18.0 dBm, Modulation: 802.11g - 64QAM @ 54 Mbps
- Trace 1: RBW= 1 MHz, VBW= 3 MHz
- Trace 2: RBW= 500 kHz, VBW= 1 MHz
- Trace 3: RBW= 1 MHz, VBW= 10 Hz

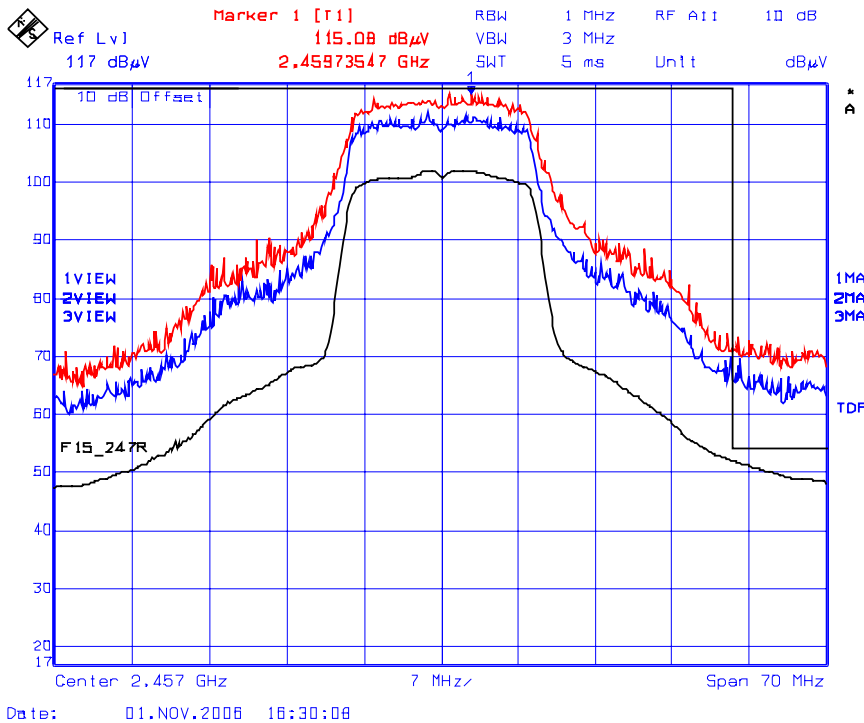

ULTRATECH GROUP OF LABS

3000 Bristol Circle, Oakville, Ontario, Canada L6H 6G4
Tel. #: 905-829-1570, Fax. #: 905-829-8050, Email: vic@ultratech-labs.com, Website: <http://www.ultratech-labs.com>

File #: CNI-080FCC15CE – 041207

Apr. 12, 2007

- All test results contained in this engineering test report are traceable to National Institute of Standards and Technology (NIST)

Plot 16(a): Upper Band-Edge Transmitter Radiated Emissions @ 3 Meters, Horizontal Polarization

- Freq.: 2462 MHz, Power Setting: 15 dBm, Modulation: 802.11g - 64QAM @ 54 Mbps
- Trace 1: RBW= 1 MHz, VBW= 3 MHz
- Trace 2: RBW= 500 kHz, VBW= 1 MHz, Delta (Peak to Band-Edge): 43.20 dB
- Trace 3: RBW= 1 MHz, VBW= 10 Hz
- Band-Edge Level at 2483.5 MHz: 114.91dBuV/m – 43.20 dB= 71.71dBuV/m (Limit 74dBu/m)

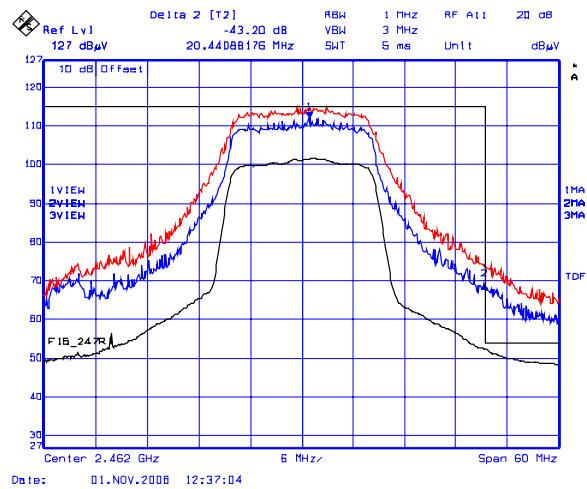
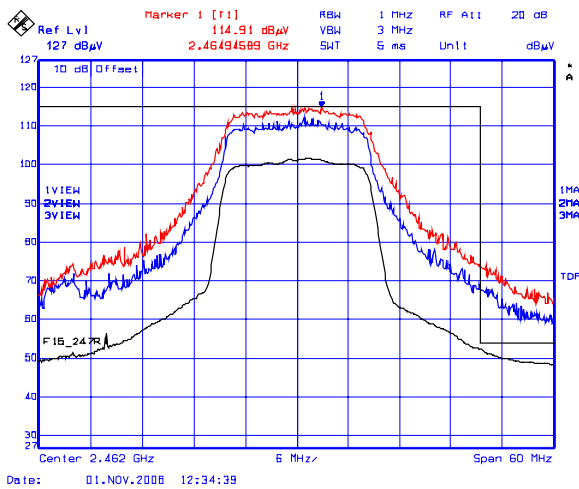

Plot 16(b): Upper Band-Edge Transmitter Radiated Emissions @ 3 Meters, Vertical Polarization

- Freq.: 2462 MHz, Power Setting: 15 dBm, Modulation: 802.11g - 64QAM @ 54 Mbps
- Trace 1: RBW= 1 MHz, VBW= 3 MHz
- Trace 2: RBW= 500 kHz, VBW= 1 MHz
- Trace 3: RBW= 1 MHz, VBW= 10 Hz

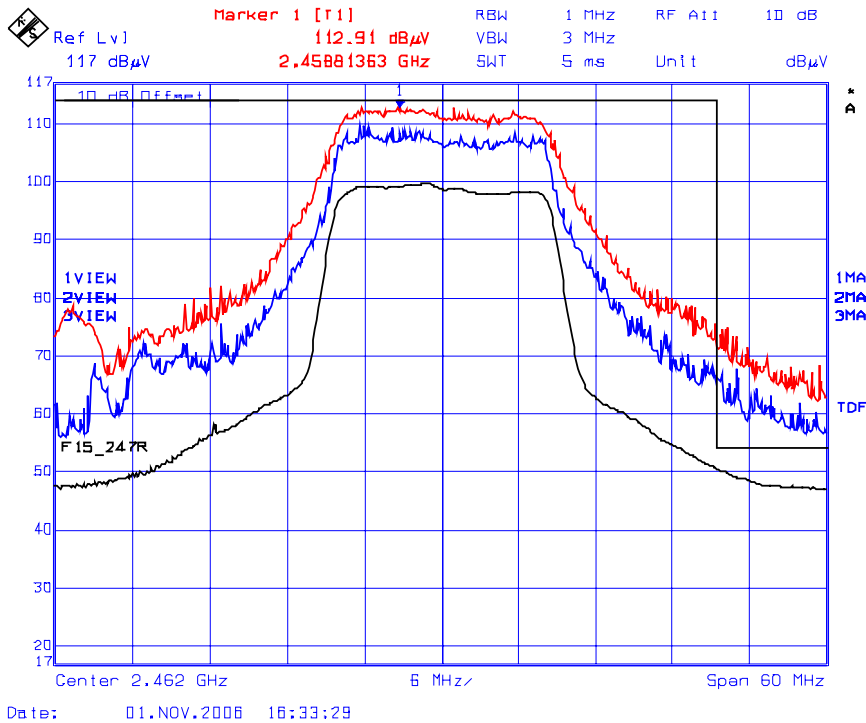

Plot 17(a): Lower Band-Edge Transmitter Radiated Emissions @ 3 Meters, Horizontal Polarization

- Freq.: 5745 MHz, Power Setting: 20 dBm, Modulation: 802.11a - 64QAM @ 54 Mbps
- RBW= 1 MHz, VBW= 3 MHz, Peak Detector Max Hold

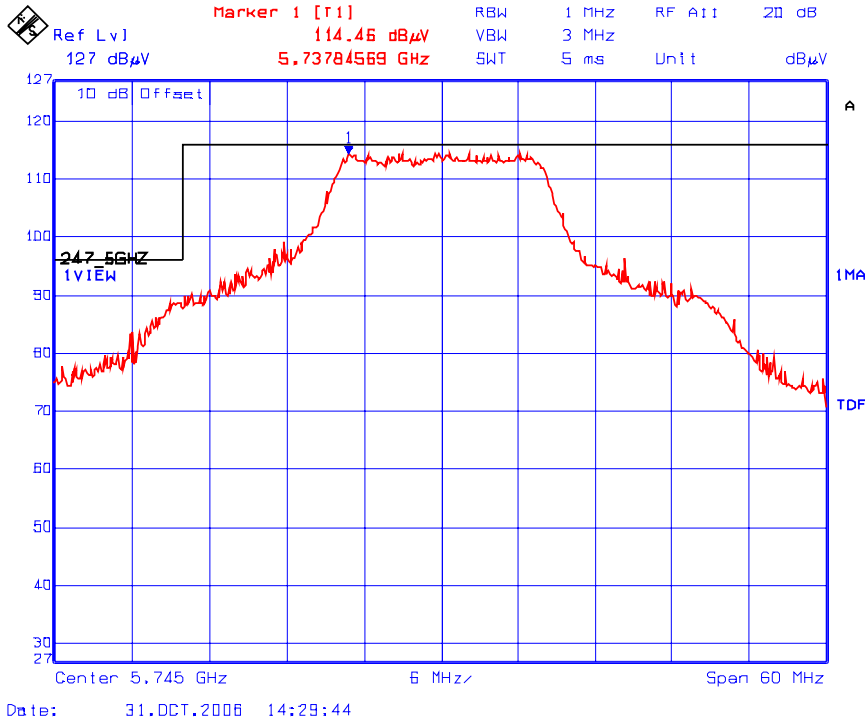

Plot 17(b): Lower Band-Edge Transmitter Radiated Emissions @ 3 Meters, Vertical Polarization

- Freq.: 5745 MHz, Power Setting: 20 dBm, Modulation: 802.11a - 64QAM @ 54 Mbps
- RBW= 1 MHz, VBW= 3 MHz, Peak Detector Max Hold

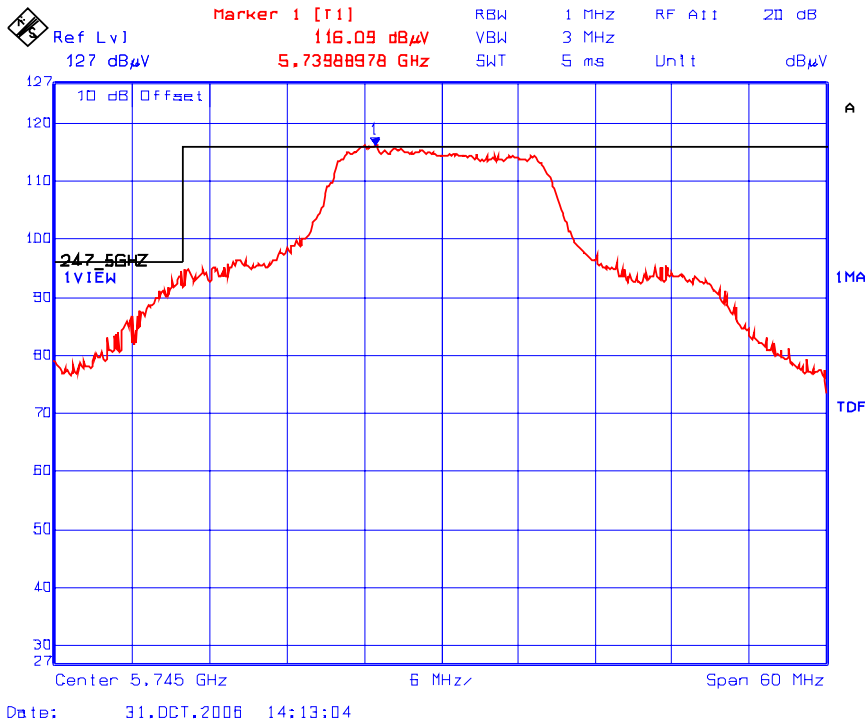

ULTRATECH GROUP OF LABS

3000 Bristol Circle, Oakville, Ontario, Canada L6H 6G4
Tel. #: 905-829-1570, Fax. #: 905-829-8050, Email: vic@ultratech-labs.com, Website: <http://www.ultratech-labs.com>

File #: CNI-080FCC15CE – 041207

Apr. 12, 2007

- All test results contained in this engineering test report are traceable to National Institute of Standards and Technology (NIST)

Plot 18(a): Upper Band-Edge Transmitter Radiated Emissions @ 3 Meters, Horizontal Polarization

- Freq.: 5825 MHz, Power Setting: 20 dBm, Modulation: 802.11a - 64QAM @ 54 Mbps
- RBW= 1 MHz, VBW= 3 MHz, Peak Detector Max Hold

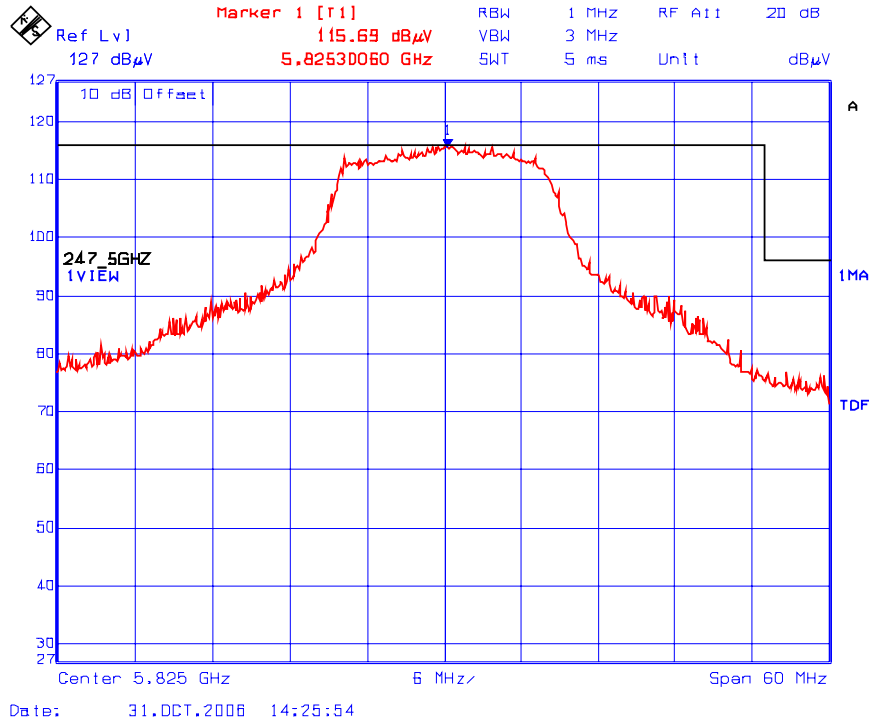

Plot 18(b): Upper Band-Edge Transmitter Radiated Emissions @ 3 Meters, Vertical Polarization

- Freq.: 5825 MHz, Power Setting: 20 dBm, Modulation: 802.11a - 64QAM @ 54 Mbps
- RBW= 1 MHz, VBW= 3 MHz, Peak Detector Max Hold

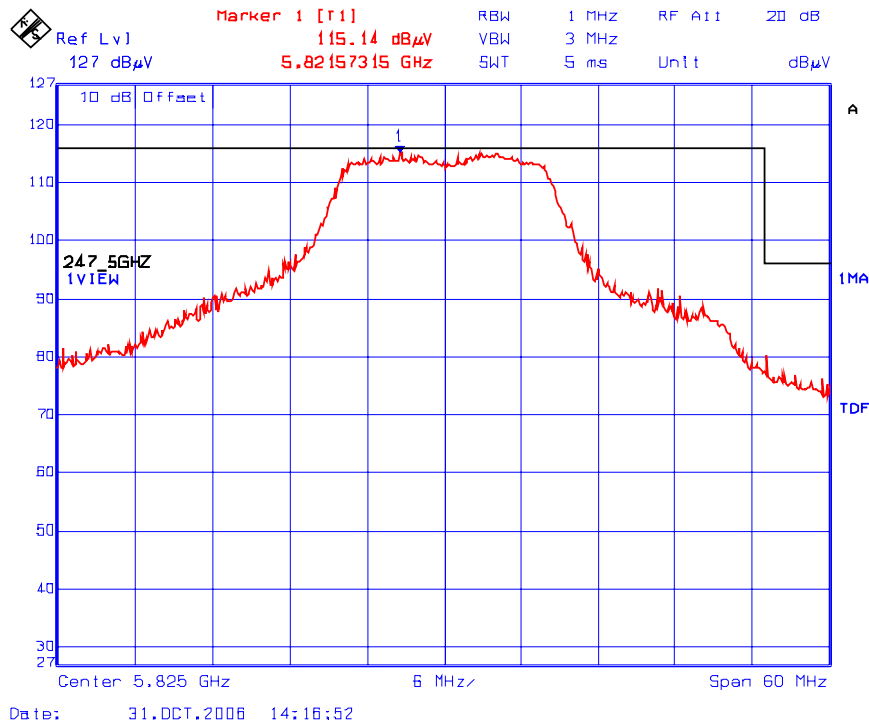

5.2.5.1.2. Internal Antennas

Conforms. Please see the following test data Plots 19(a)(b) – 34(a)(b) for detailed measurements of band-edge emissions.

Plot 19(a): Lower Band-Edge Transmitter Radiated Emissions @ 3 Meters, Horizontal Polarization

- Freq.: 2412 MHz, Power Setting: 18.5 dBm, Modulation: 802.11b – CCK @ 11Mb/s
Trace 1: RBW= 1 MHz, VBW= 3 MHz
Trace 2: RBW= 500 kHz, VBW= 1 MHz
Trace 3: RBW= 1 MHz, VBW= 10 Hz

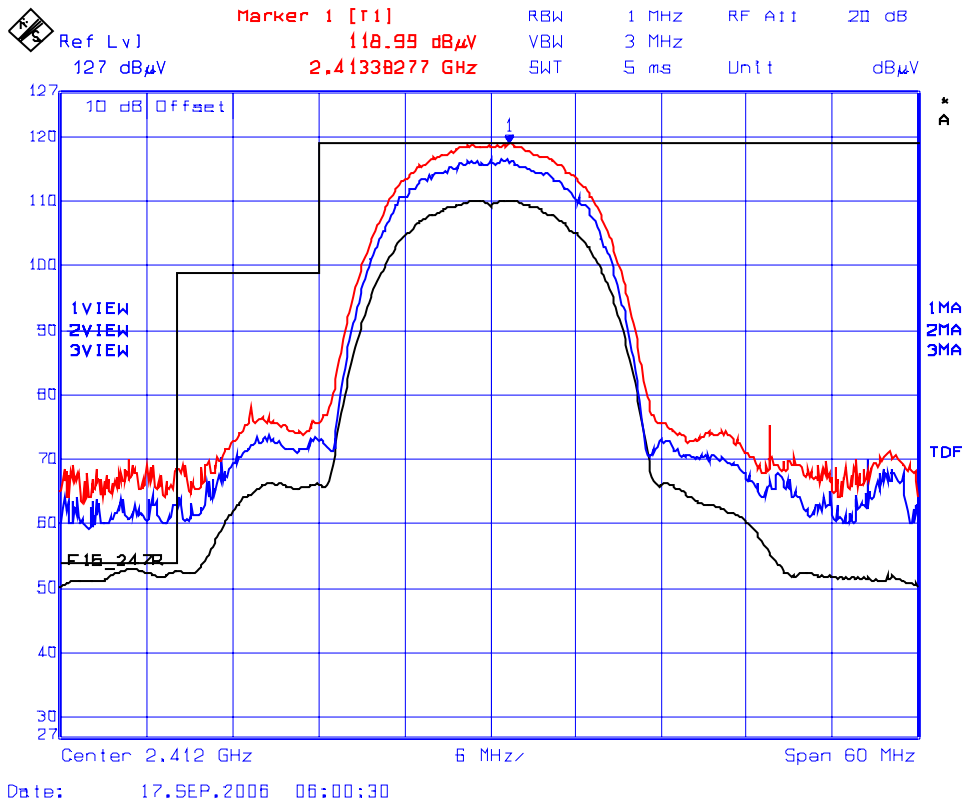

Plot 19(b): Lower Band-Edge Transmitter Radiated Emissions @ 3 Meters, Vertical Polarization

- Freq.: 2412 MHz, Power Setting: 18.5 dBm, Modulation: 802.11b – CCK @ 11Mb/s
Trace 1: RBW= 1 MHz, VBW= 3 MHz
Trace 2: RBW= 500 kHz, VBW= 1 MHz
Trace 3: RBW= 1 MHz, VBW= 10 Hz

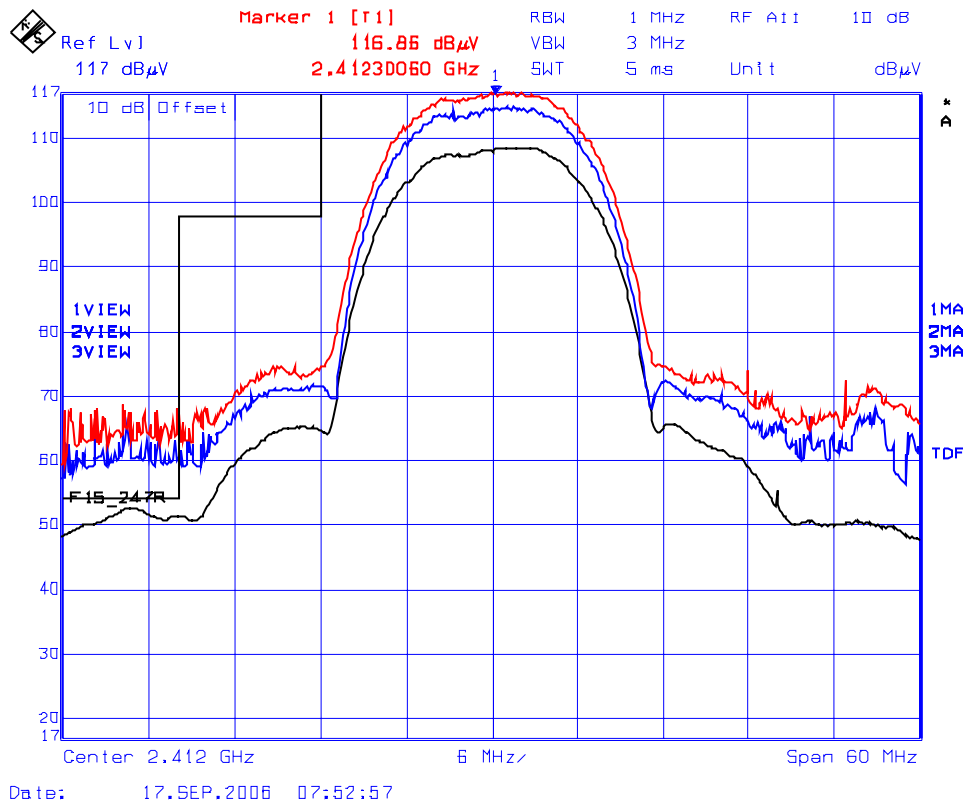

ULTRATECH GROUP OF LABS

3000 Bristol Circle, Oakville, Ontario, Canada L6H 6G4
Tel. #: 905-829-1570, Fax. #: 905-829-8050, Email: vic@ultratech-labs.com, Website: <http://www.ultratech-labs.com>

File #: CNI-080FCC15CE – 041207

Apr. 12, 2007

- All test results contained in this engineering test report are traceable to National Institute of Standards and Technology (NIST)

Plot 20(a): Inner Band-Edge Transmitter Radiated Emissions @ 3 Meters, Horizontal Polarization

- Freq.: 2417 MHz, Power Setting: 19.0 dBm, Modulation: 802.11b – CCK @ 11Mb/s
Trace 1: RBW= 1 MHz, VBW= 3 MHz
Trace 2: RBW= 500 kHz, VBW= 1 MHz
Trace 3: RBW= 1 MHz, VBW= 10 Hz

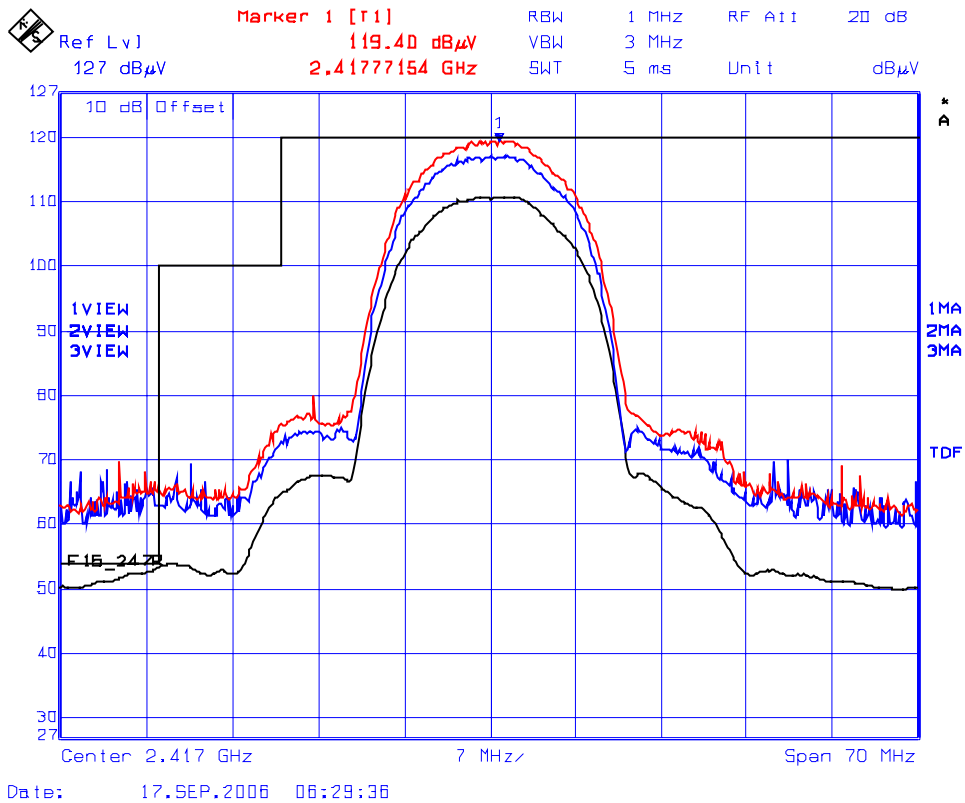

Plot 20(b): Inner Band-Edge Transmitter Radiated Emissions @ 3 Meters, Vertical Polarization

- Freq.: 2417 MHz, Power Setting: 19.0 dBm, Modulation: 802.11b – CCK @ 11Mb/s
Trace 1: RBW= 1 MHz, VBW= 3 MHz
Trace 2: RBW= 500 kHz, VBW= 1 MHz
Trace 3: RBW= 1 MHz, VBW= 10 Hz

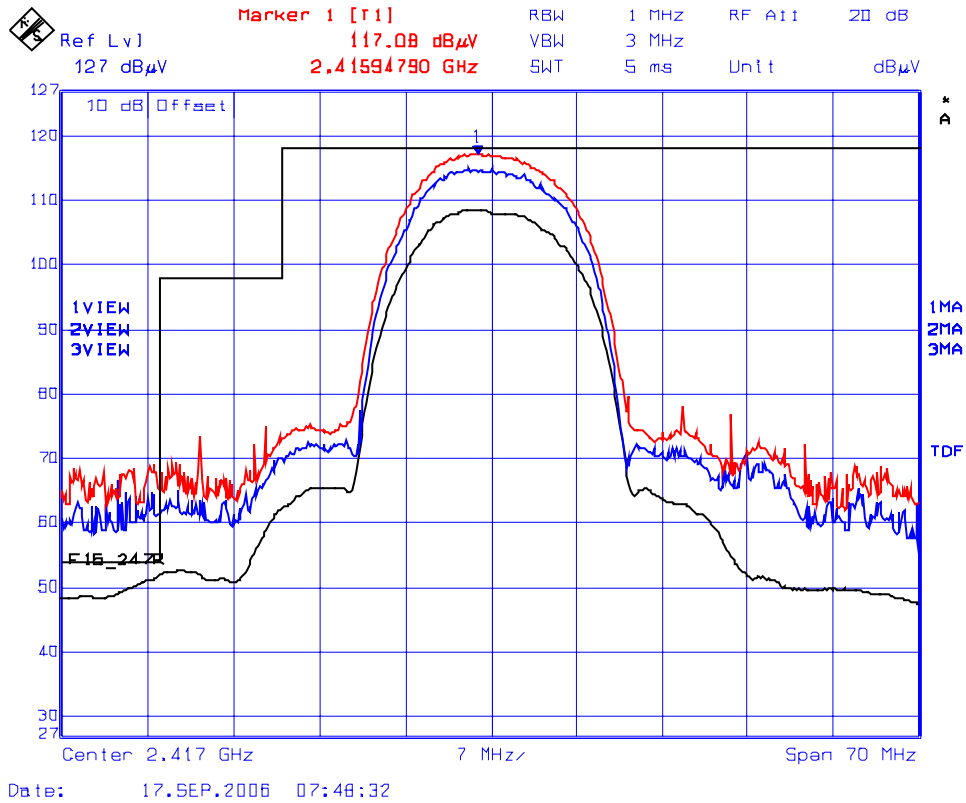

Plot 21(a): Inner Band-Edge Transmitter Radiated Emissions @ 3 Meters, Horizontal Polarization

- Freq.: 2422 MHz, Power Setting: 20.0 dBm, Modulation: 802.11b – CCK @ 11Mb/s
Trace 1: RBW= 1 MHz, VBW= 3 MHz
Trace 2: RBW= 500 kHz, VBW= 1 MHz
Trace 3: RBW= 1 MHz, VBW= 10 Hz

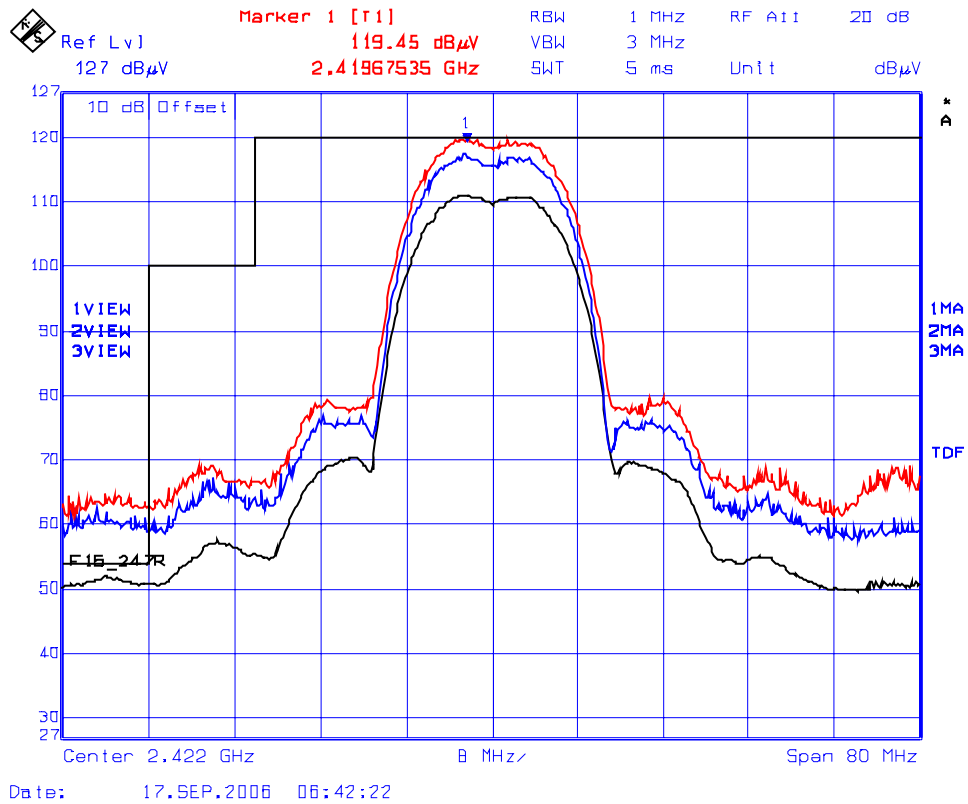

Plot 21(b): Inner Band-Edge Transmitter Radiated Emissions @ 3 Meters, Vertical Polarization

- Freq.: 2422 MHz, Power Setting: 20.0 dBm, Modulation: 802.11b – CCK @ 11Mb/s
Trace 1: RBW= 1 MHz, VBW= 3 MHz
Trace 2: RBW= 500 kHz, VBW= 1 MHz
Trace 3: RBW= 1 MHz, VBW= 10 Hz

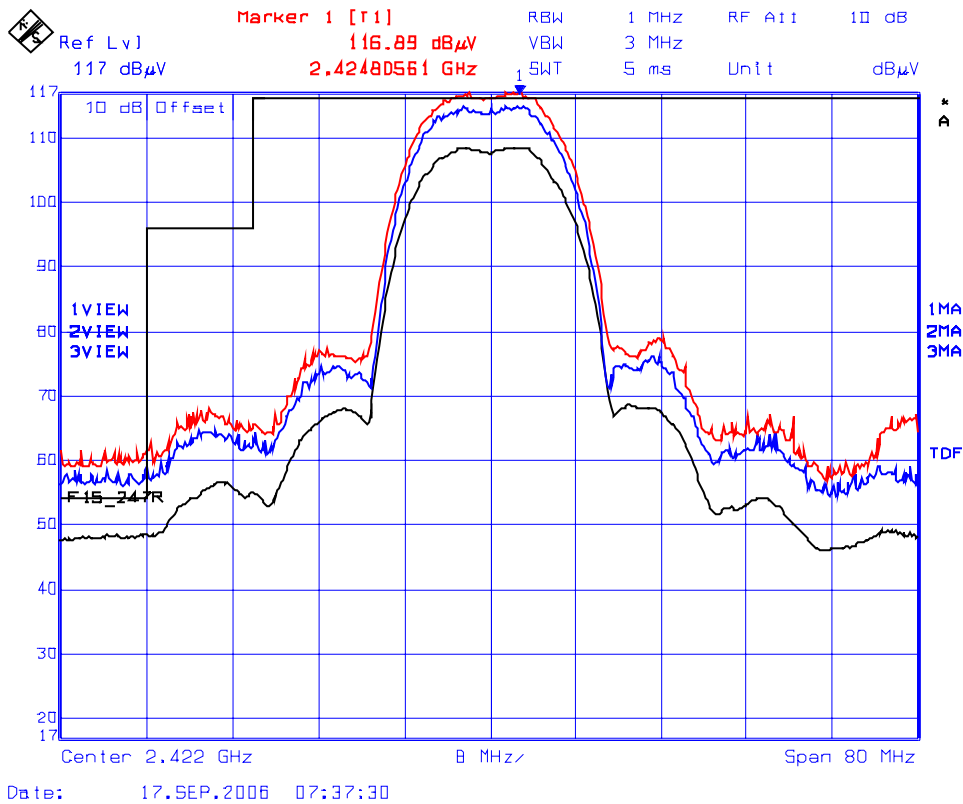

Plot 22(a): Inner Band-Edge Transmitter Radiated Emissions @ 3 Meters, Horizontal Polarization

- Freq.: 2462 MHz, Power Setting: 20.0 dBm, Modulation: 802.11b – CCK @ 11Mb/s
 Trace 1: RBW= 1 MHz, VBW= 3 MHz
 Trace 2: RBW= 500 kHz, VBW= 1 MHz
 Trace 3: RBW= 1 MHz, VBW= 10 Hz

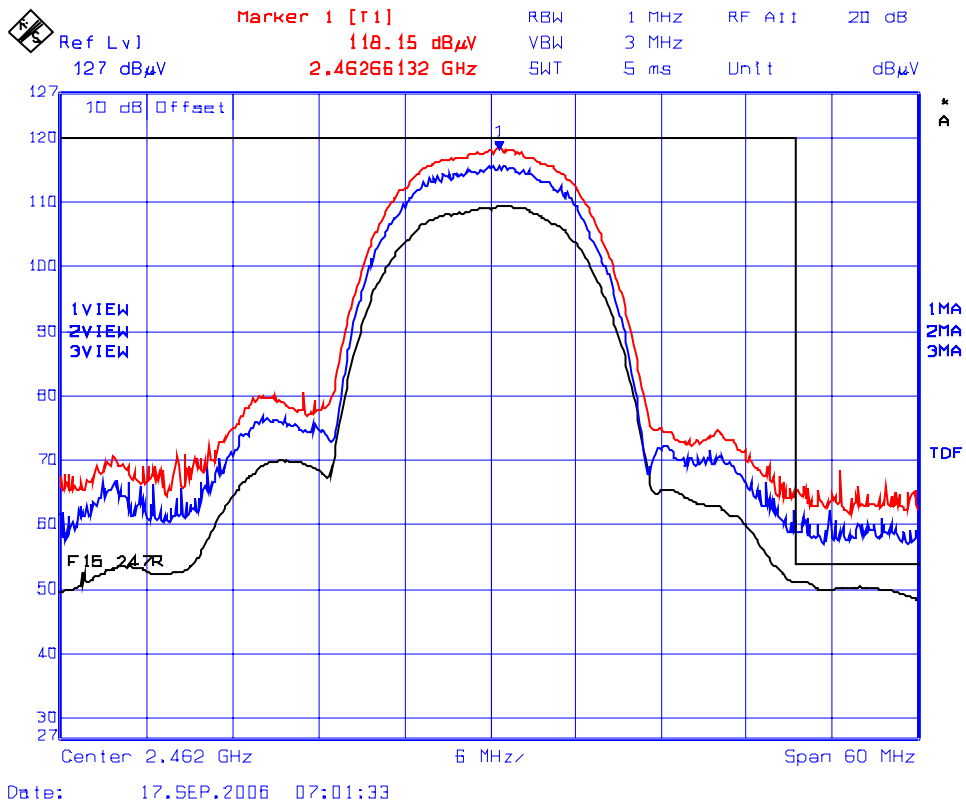

Plot 22(b): Inner Band-Edge Transmitter Radiated Emissions @ 3 Meters, Vertical Polarization

- Freq.: 2462 MHz, Power Setting: 20.0 dBm, Modulation: 802.11b – CCK @ 11Mb/s
Trace 1: RBW= 1 MHz, VBW= 3 MHz
Trace 2: RBW= 500 kHz, VBW= 1 MHz
Trace 3: RBW= 1 MHz, VBW= 10 Hz

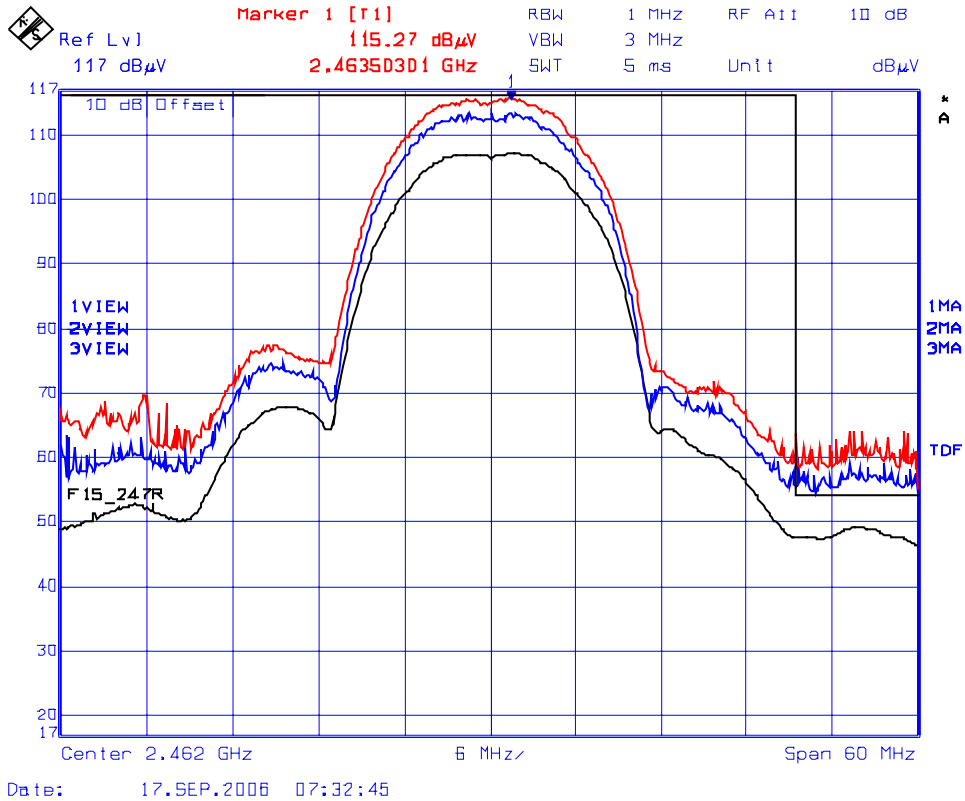

Plot 23(a): Lower Band-Edge Transmitter Radiated Emissions @ 3 Meters, Horizontal Polarization

- Freq.: 2412 MHz, Power Setting: 14.0 dBm, Modulation: 802.11g - 64QAM @ 54 Mbps
Trace 1: RBW= 1 MHz, VBW= 3 MHz
Trace 2: RBW= 500 kHz, VBW= 1 MHz, Delta (Peak to Band-Edge): 42.66 dB
Trace 3: RBW= 1 MHz, VBW= 10 Hz
Band-Edge Level at 2389 MHz: 115.15dBuV/m – 42.66 dB= 72.49dBuV/m (Limit 74dBu/m)

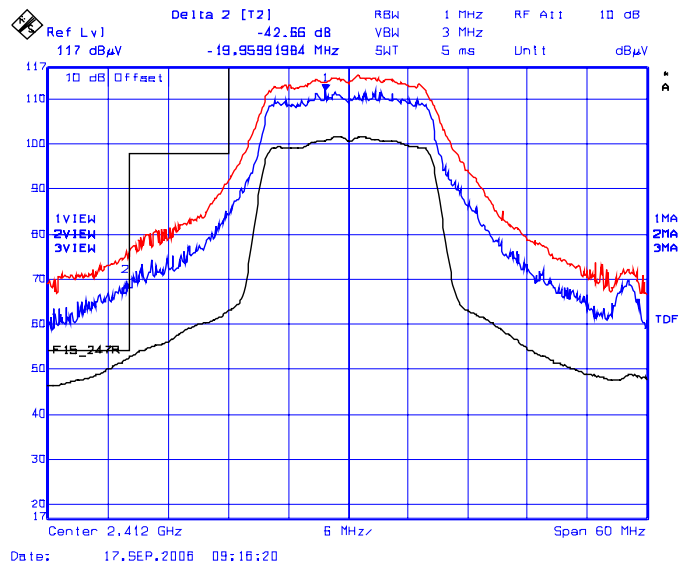
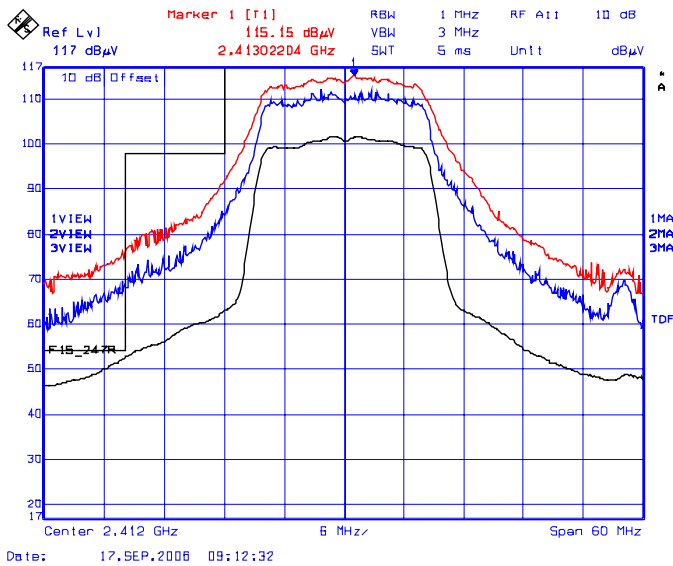

Plot 23(b): Lower Band-Edge Transmitter Radiated Emissions @ 3 Meters, Vertical Polarization

- Freq.: 2412 MHz, Power Setting: 14.0 dBm, Modulation: 802.11g - 64QAM @ 54 Mbps
Trace 1: RBW= 1 MHz, VBW= 3 MHz
Trace 2: RBW= 500 kHz, VBW= 1 MHz, Delta (Peak to Band-Edge): 43.70 dB
Trace 3: RBW= 1 MHz, VBW= 10 Hz
Band-Edge Level at 2389 MHz: 114.38dBuV/m – 43.70 dB= 70.68dBuV/m (Limit 74dBu/m)

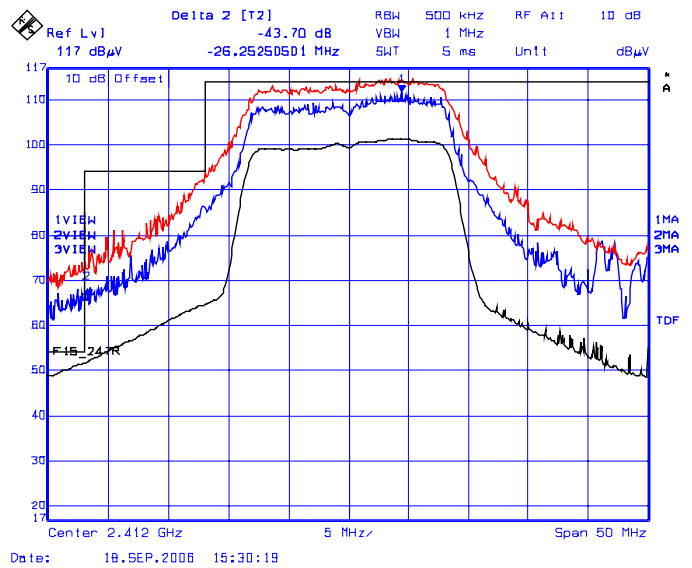
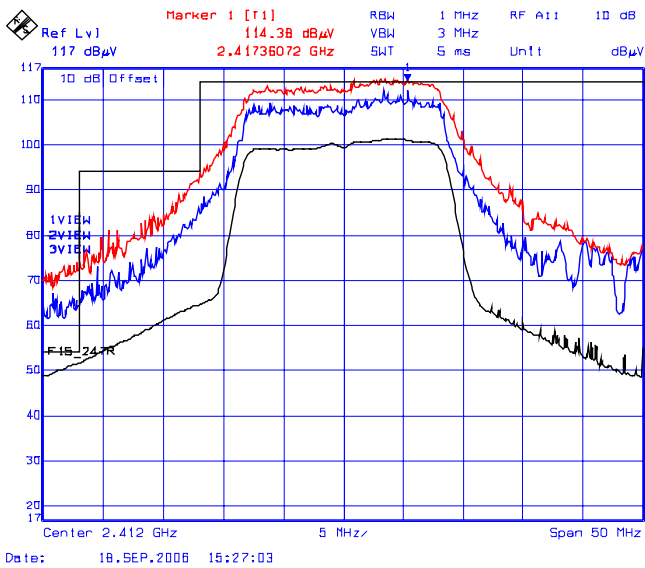

Plot 24(a): Inner Band-Edge Transmitter Radiated Emissions @ 3 Meters, Horizontal Polarization

- Freq.: 2417 MHz, Power Setting: 16.0 dBm, Modulation: 802.11g - 64QAM @ 54 Mbps
Trace 1: RBW= 1 MHz, VBW= 3 MHz
Trace 2: RBW= 500 kHz, VBW= 1 MHz, Delta (Peak to Band-Edge): 43.15 dB
Trace 3: RBW= 1 MHz, VBW= 10 Hz
Band-Edge Level at 2389 MHz: 116.05dBuV/m – 43.15 dB= 72.90BuV/m (Limit 74dBu/m)

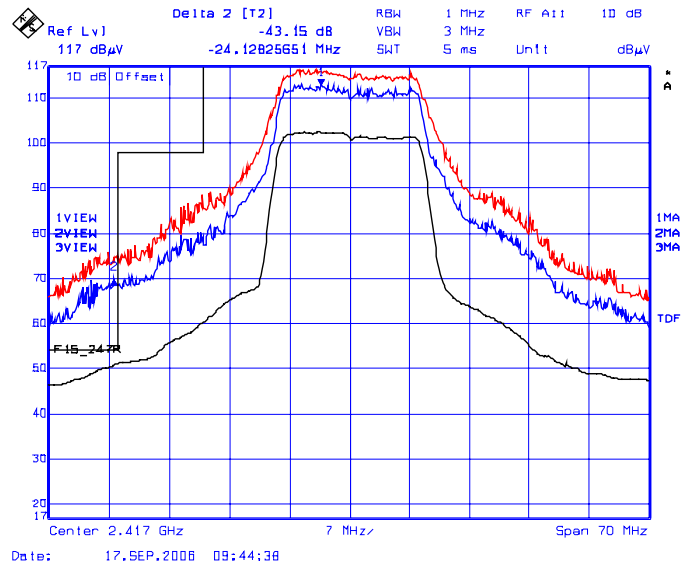
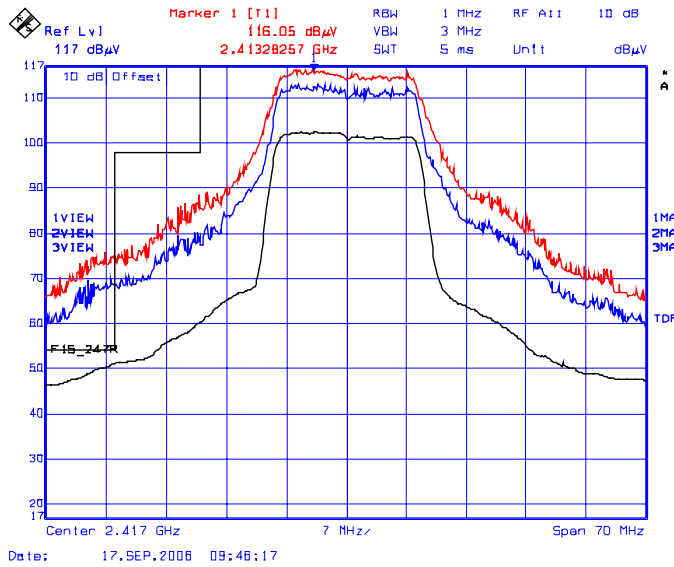

Plot 24(b): Inner Band-Edge Transmitter Radiated Emissions @ 3 Meters, Vertical Polarization

- Freq.: 2417 MHz, Power Setting: 16.0 dBm, Modulation: 802.11g - 64QAM @ 54 Mbps
Trace 1: RBW= 1 MHz, VBW= 3 MHz
Trace 2: RBW= 500 kHz, VBW= 1 MHz, Delta (Peak to Band-Edge): 44.90 dB
Trace 3: RBW= 1 MHz, VBW= 10 Hz
Band-Edge Level at 2389 MHz: 116.41dBuV/m – 44.90 dB= 71.51BuV/m (Limit 74dBu/m)

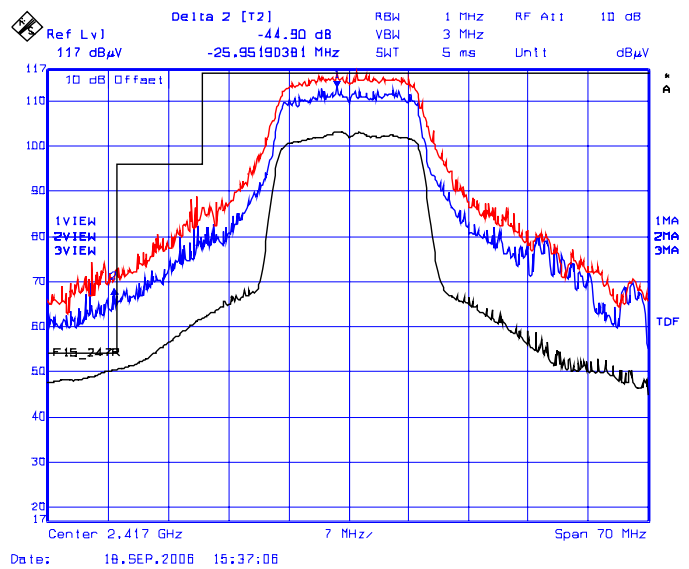
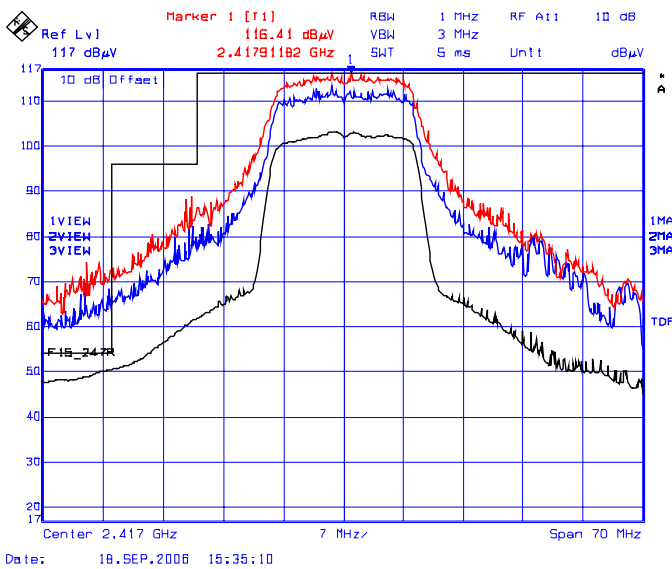

Plot 25(a): Inner Band-Edge Transmitter Radiated Emissions @ 3 Meters, Horizontal Polarization

- Freq.: 2422 MHz, Power Setting: 17.5 dBm, Modulation: 802.11g - 64QAM @ 54 Mbps
Trace 1: RBW= 1 MHz, VBW= 3 MHz
Trace 2: RBW= 500 kHz, VBW= 1 MHz, Delta (Peak to Band-Edge): 43.99 dB
Trace 3: RBW= 1 MHz, VBW= 10 Hz
Band-Edge Level at 2389 MHz: 117.18dBuV/m – 43.99 dB= 73.19dBuV/m (Limit 74dBu/m)

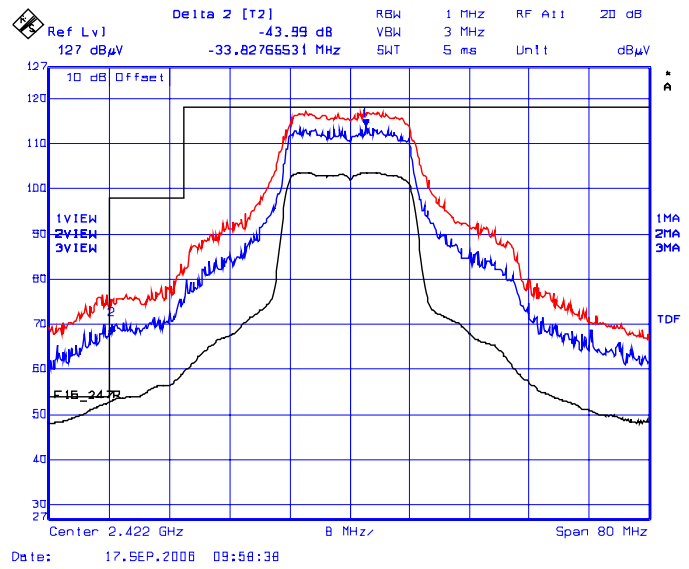
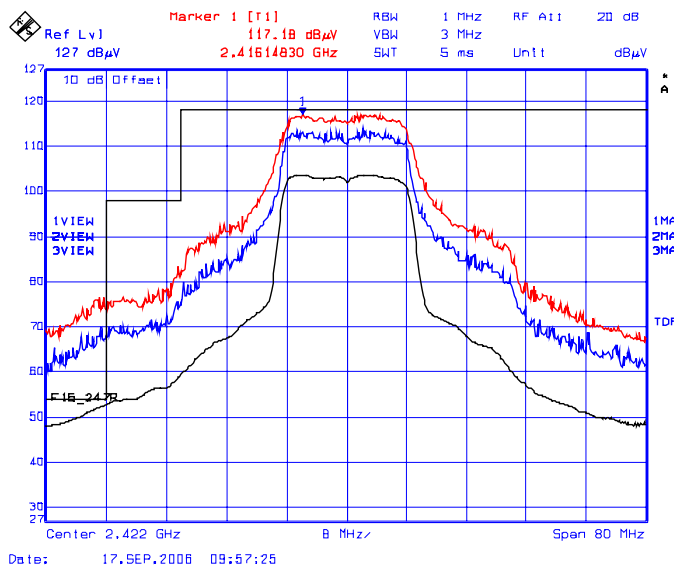

Plot 25(b): Inner Band-Edge Transmitter Radiated Emissions @ 3 Meters, Vertical Polarization

- Freq.: 2422 MHz, Power Setting: 17.5 dBm, Modulation: 802.11g - 64QAM @ 54 Mbps
Trace 1: RBW= 1 MHz, VBW= 3 MHz
Trace 2: RBW= 500 kHz, VBW= 1 MHz, Delta (Peak to Band-Edge): 45.78 dB
Trace 3: RBW= 1 MHz, VBW= 10 Hz
Band-Edge Level at 2389 MHz: 117.51dBuV/m – 45.78 dB= 71.73dBuV/m (Limit 74dBuV/m)

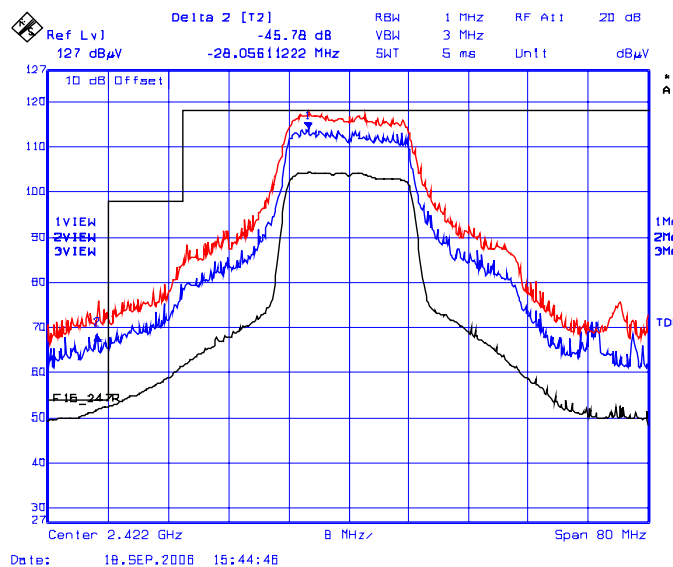
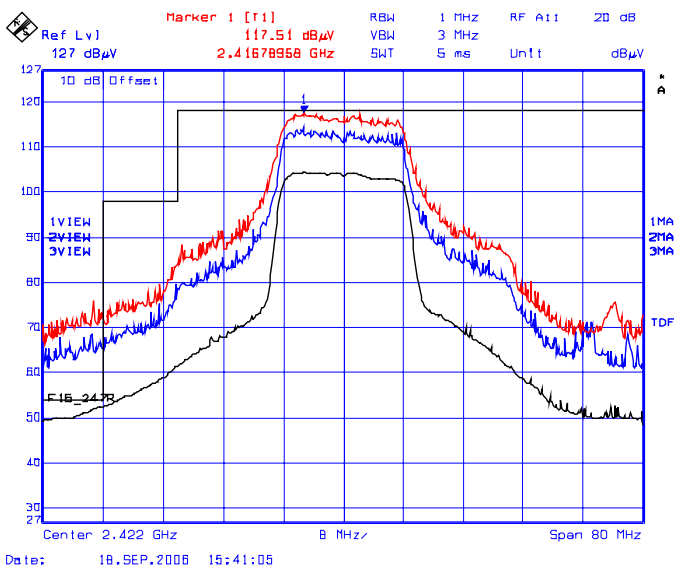

Plot 26(a): Inner Band-Edge Transmitter Radiated Emissions @ 3 Meters, Horizontal Polarization

- Freq.: 2427 MHz, Power Setting: 18.0 dBm, Modulation: 802.11g - 64QAM @ 54 Mbps
Trace 1: RBW= 1 MHz, VBW= 3 MHz
Trace 2: RBW= 500 kHz, VBW= 1 MHz, Delta (Peak to Band-Edge): 45.13 dB
Trace 3: RBW= 1 MHz, VBW= 10 Hz
Band-Edge Level at 2389 MHz: 117.58dBuV/m – 45.13 dB= 72.45dBuV/m (Limit 74dBuV/m)

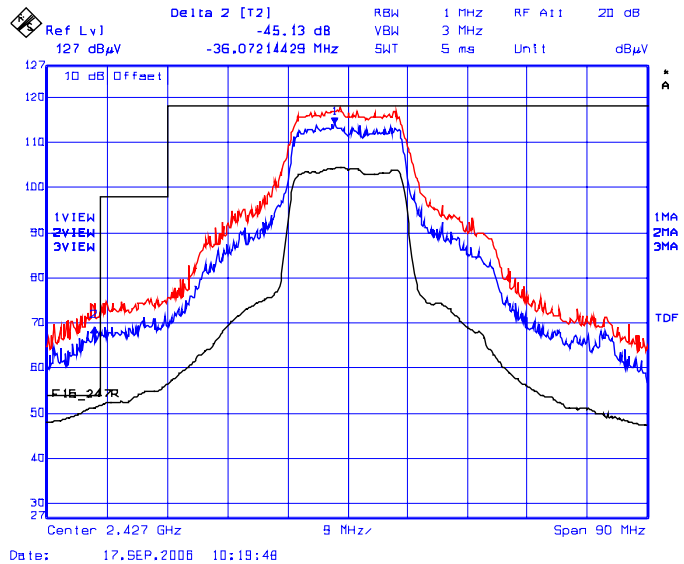
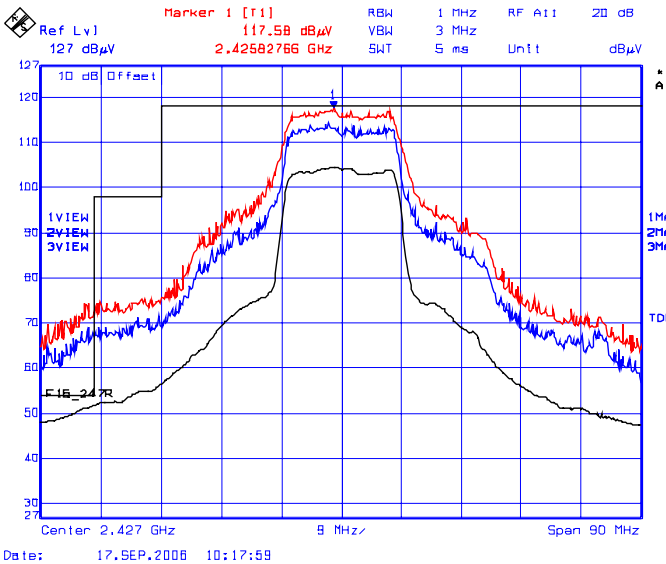

Plot 26(b): Inner Band-Edge Transmitter Radiated Emissions @ 3 Meters, Vertical Polarization

- Freq.: 2427 MHz, Power Setting: 18.0 dBm, Modulation: 802.11g - 64QAM @ 54 Mbps
Trace 1: RBW= 1 MHz, VBW= 3 MHz
Trace 2: RBW= 500 kHz, VBW= 1 MHz, Delta (Peak to Band-Edge): 46.94 dB
Trace 3: RBW= 1 MHz, VBW= 10 Hz
Band-Edge Level at 2389 MHz: 117.63dBuV/m – 46.94 dB= 70.69dBuV/m (Limit 74dBu/m)

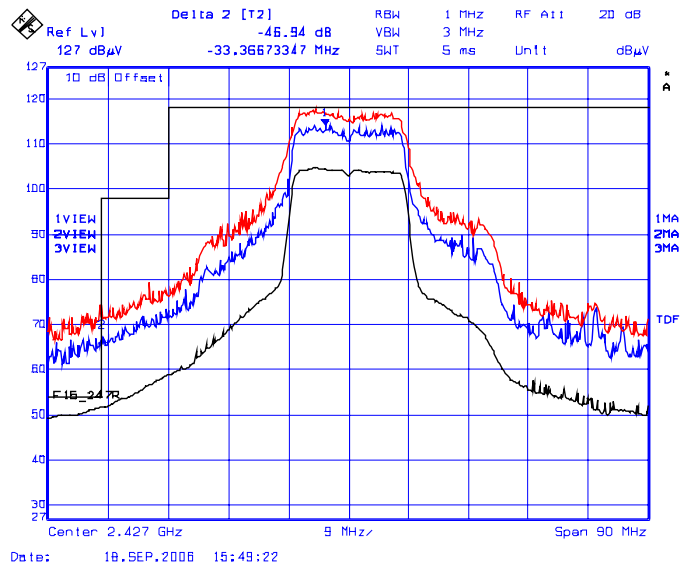
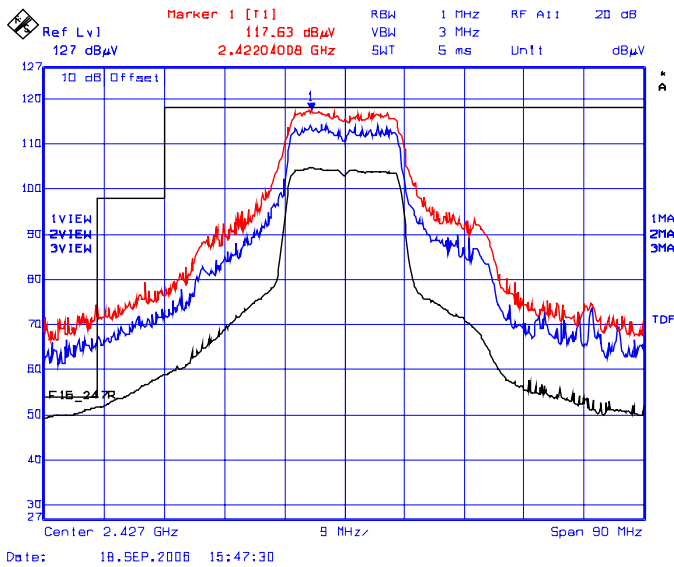

Plot 27(a): Inner Band-Edge Transmitter Radiated Emissions @ 3 Meters, Horizontal Polarization

- Freq.: 2432 MHz, Power Setting: 18.0 dBm, Modulation: 802.11g - 64QAM @ 54 Mbps
Trace 1: RBW= 1 MHz, VBW= 3 MHz
Trace 2: RBW= 500 kHz, VBW= 1 MHz, Delta (Peak to Band-Edge): 47.06 dB
Trace 3: RBW= 1 MHz, VBW= 10 Hz
Band-Edge Level at 2389 MHz: 119.43dBuV/m – 47.06 dB= 72.37dBuV/m (Limit 74dBu/m)

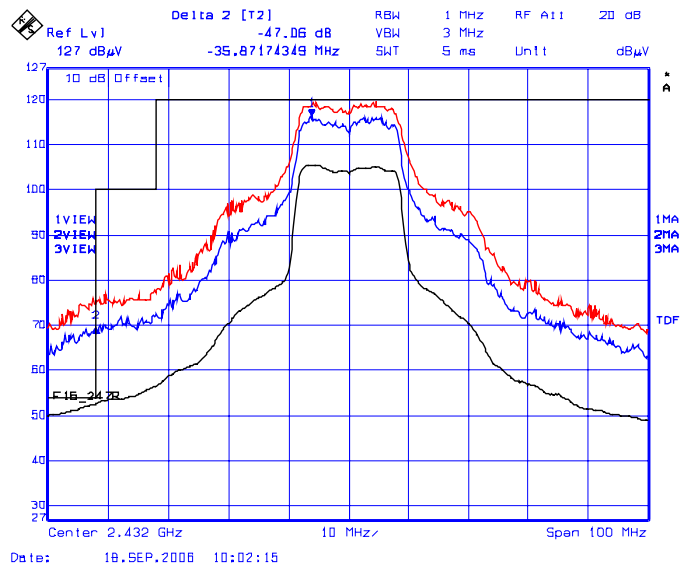
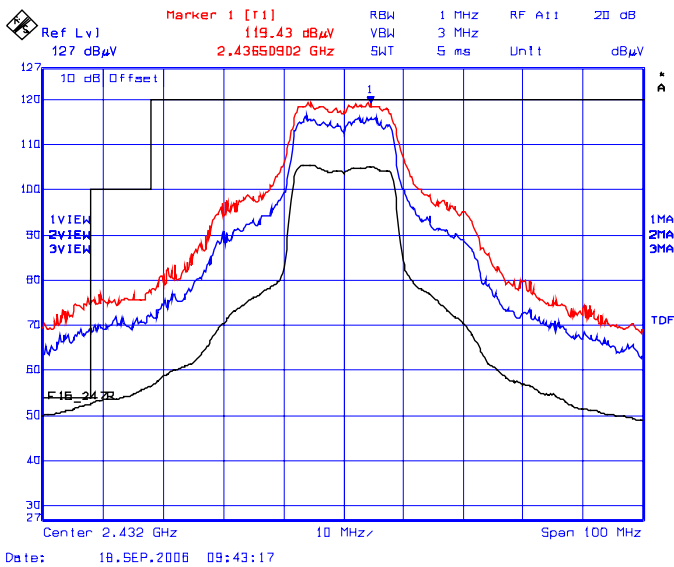

Plot 27(b): Inner Band-Edge Transmitter Radiated Emissions @ 3 Meters, Vertical Polarization

- Freq.: 2432 MHz, Power Setting: 18.0 dBm, Modulation: 802.11g - 64QAM @ 54 Mbps
Trace 1: RBW= 1 MHz, VBW= 3 MHz
Trace 2: RBW= 500 kHz, VBW= 1 MHz, Delta (Peak to Band-Edge): 45.75 dB
Trace 3: RBW= 1 MHz, VBW= 10 Hz
Band-Edge Level at 2389 MHz: 118.39dBuV/m – 45.75 dB= 72.64dBuV/m (Limit 74dBu/m)

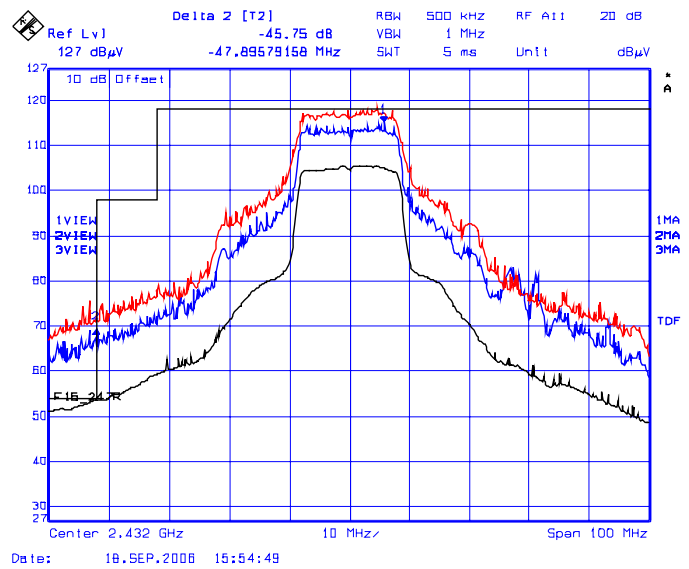
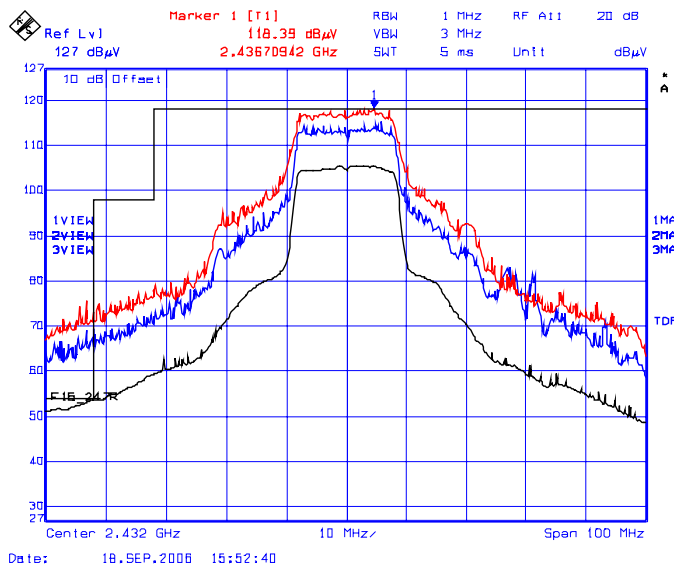

Plot 28(a): Inner Band-Edge Transmitter Radiated Emissions @ 3 Meters, Horizontal Polarization

- Freq.: 2442 MHz, Power Setting: 18.0 dBm, Modulation: 802.11g - 64QAM @ 54 Mbps
Trace 1: RBW= 1 MHz, VBW= 3 MHz
Trace 2: RBW= 500 kHz, VBW= 1 MHz, Delta (Peak to Band-Edge): 47.73dB
Trace 3: RBW= 1 MHz, VBW= 10 Hz
Band-Edge Level at 2483.5 MHz: 119.48dBuV/m – 47.83dB= 71.65dBuV/m (Limit 74dBu/m)

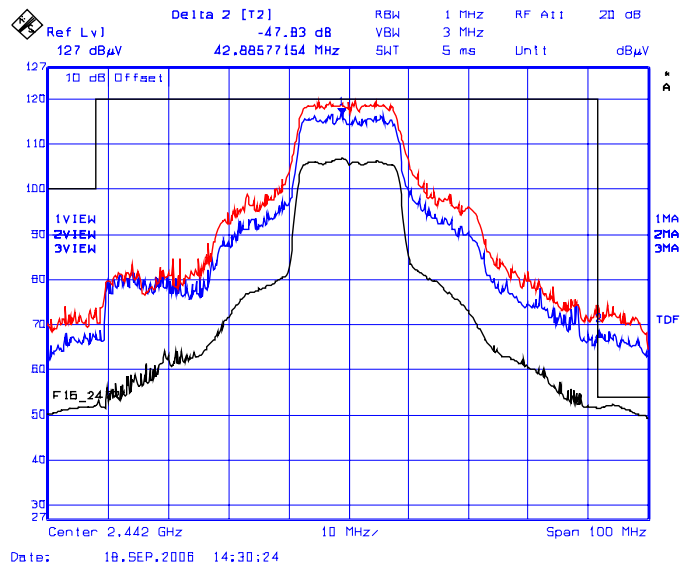
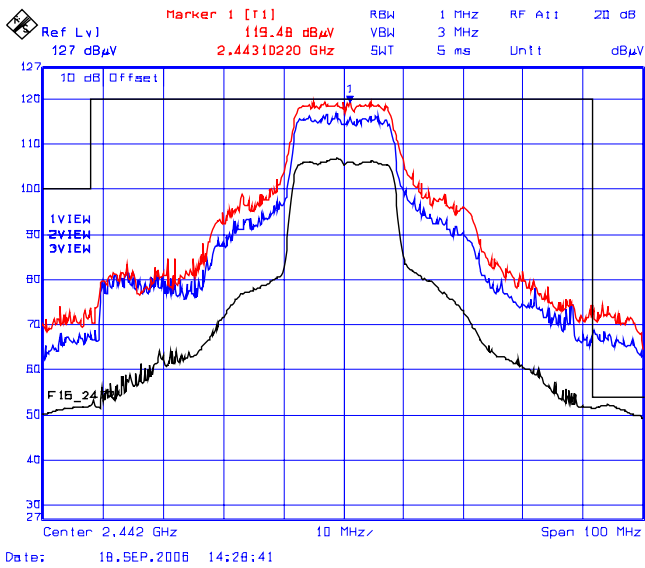

Plot 28(b): Inner Band-Edge Transmitter Radiated Emissions @ 3 Meters, Vertical Polarization

- Freq.: 2442 MHz, Power Setting: 18.0 dBm, Modulation: 802.11g - 64QAM @ 54 Mbps
Trace 1: RBW= 1 MHz, VBW= 3 MHz
Trace 2: RBW= 500 kHz, VBW= 1 MHz
Trace 3: RBW= 1 MHz, VBW= 10 Hz

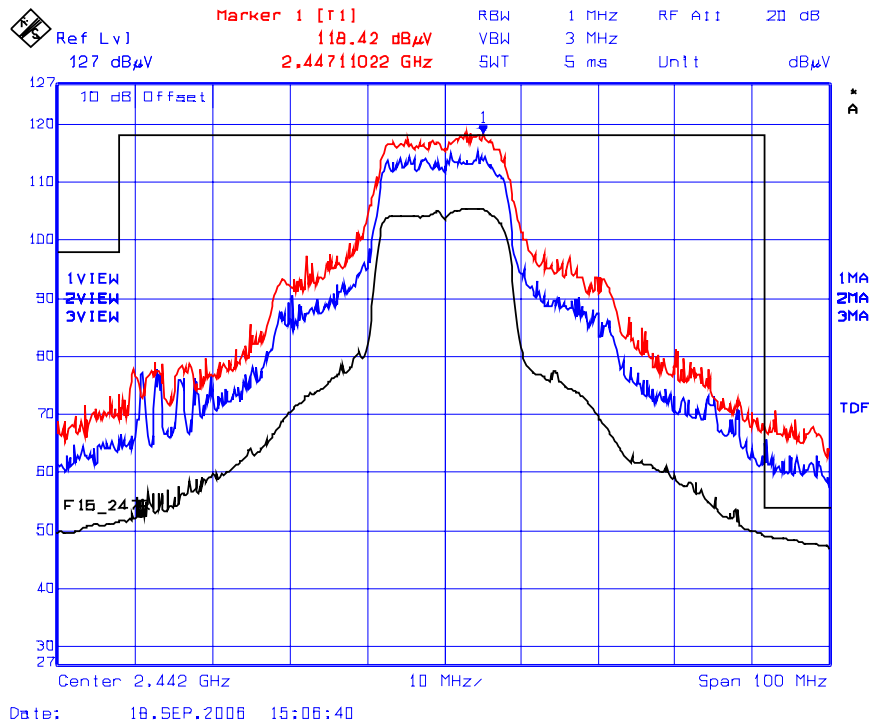

Plot 29(a): Inner Band-Edge Transmitter Radiated Emissions @ 3 Meters, Horizontal Polarization

- Freq.: 2447 MHz, Power Setting: 18.0 dBm, Modulation: 802.11g - 64QAM @ 54 Mbps
Trace 1: RBW= 1 MHz, VBW= 3 MHz
Trace 2: RBW= 500 kHz, VBW= 1 MHz, Delta (Peak to Band-Edge): 46.96dB
Trace 3: RBW= 1 MHz, VBW= 10 Hz
Band-Edge Level at 2483.5 MHz: 119.02dBuV/m – 46.96dB= 72.06dBuV/m (Limit 74dBuV/m)

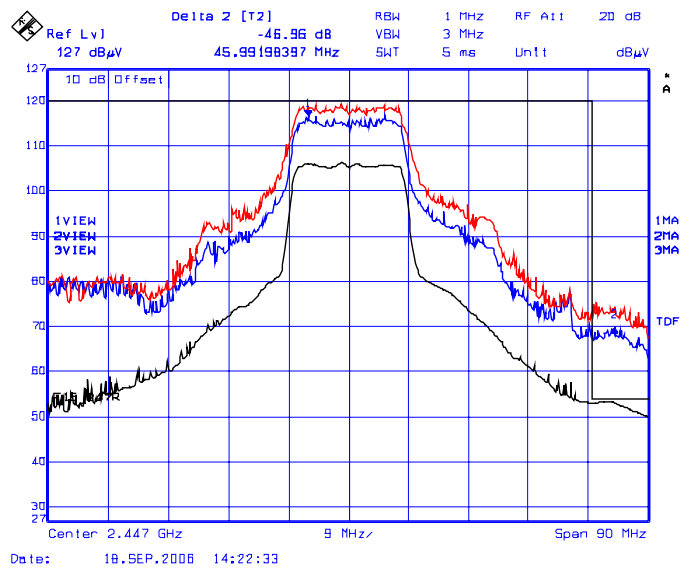
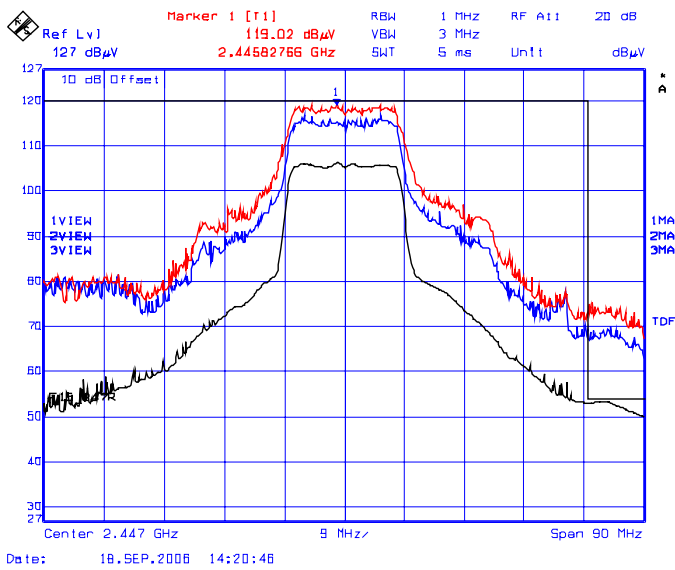

Plot 29(b): Inner Band-Edge Transmitter Radiated Emissions @ 3 Meters, Vertical Polarization

- Freq.: 2447 MHz, Power Setting: 18.0 dBm, Modulation: 802.11g - 64QAM @ 54 Mbps
Trace 1: RBW= 1 MHz, VBW= 3 MHz
Trace 2: RBW= 500 kHz, VBW= 1 MHz
Trace 3: RBW= 1 MHz, VBW= 10 Hz

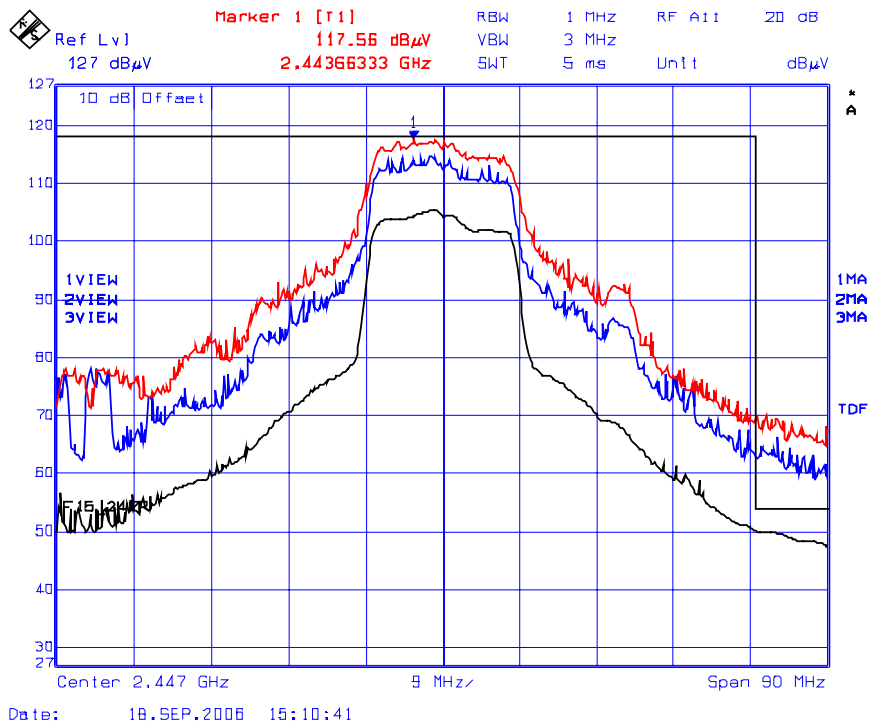

Plot 30(a): Inner Band-Edge Transmitter Radiated Emissions @ 3 Meters, Horizontal Polarization

- Freq.: 2452 MHz, Power Setting: 18.0 dBm, Modulation: 802.11g - 64QAM @ 54 Mbps
Trace 1: RBW= 1 MHz, VBW= 3 MHz
Trace 2: RBW= 500 kHz, VBW= 1 MHz, Delta (Peak to Band-Edge): 46.81dB
Trace 3: RBW= 1 MHz, VBW= 10 Hz
Band-Edge Level at 2483.5 MHz: 118.42dBuV/m – 46.81dB= 71.61dBuV/m (Limit 74dBu/m)

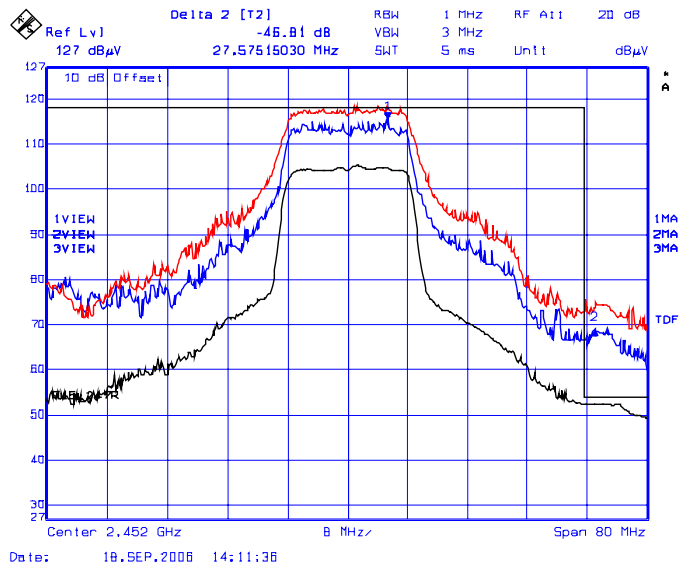
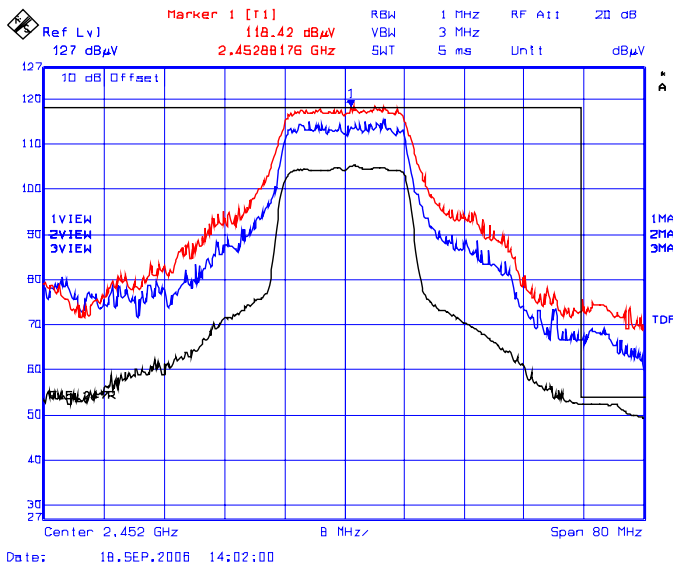

Plot 30(b): Inner Band-Edge Transmitter Radiated Emissions @ 3 Meters, Vertical Polarization

- Freq.: 2442 MHz, Power Setting: 18.0 dBm, Modulation: 802.11g - 64QAM @ 54 Mbps
- **Trace 1:** RBW= 1 MHz, VBW= 3 MHz
- **Trace 2:** RBW= 500 kHz, VBW= 1 MHz
- **Trace 3:** RBW= 1 MHz, VBW= 10 Hz

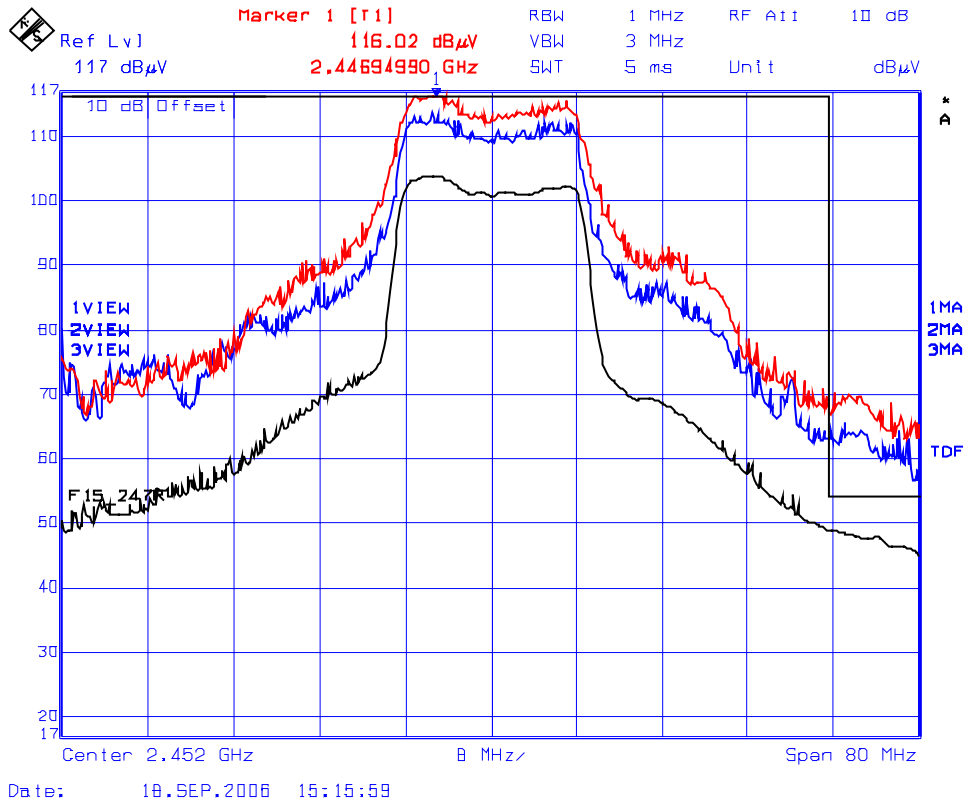

Plot 31(a): Inner Band-Edge Transmitter Radiated Emissions @ 3 Meters, Horizontal Polarization

- Freq.: 2457 MHz, Power Setting: 18.0 dBm, Modulation: 802.11g - 64QAM @ 54 Mbps
Trace 1: RBW= 1 MHz, VBW= 3 MHz
Trace 2: RBW= 500 kHz, VBW= 1 MHz, Delta (Peak to Band-Edge): 44.90dB
Trace 3: RBW= 1 MHz, VBW= 10 Hz
Band-Edge Level at 2483.5 MHz: 117.14dBuV/m – 44.90dB= 72.24dBuV/m (Limit 74dBuV/m)

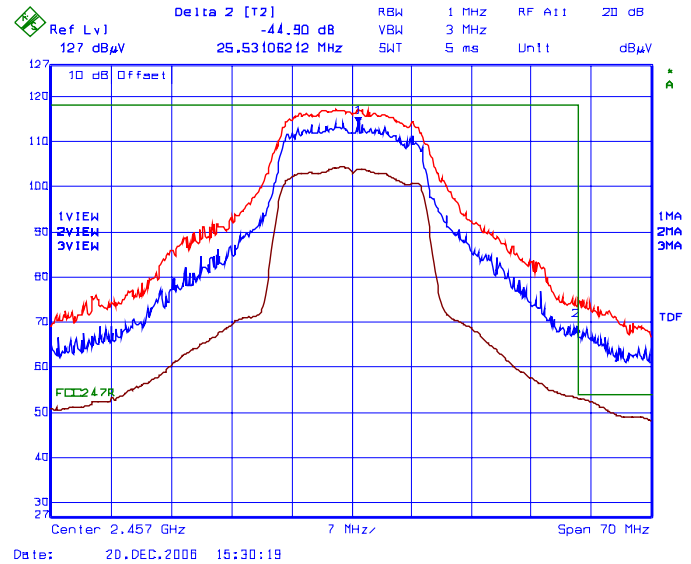
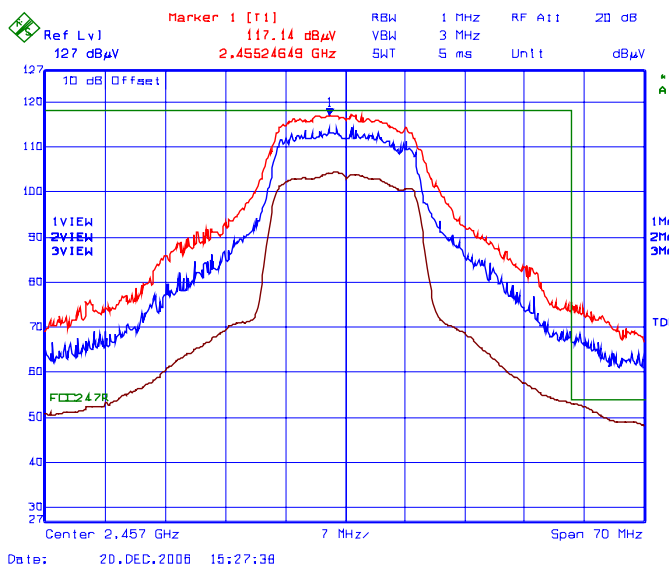

Plot 31(b): Inner Band-Edge Transmitter Radiated Emissions @ 3 Meters, Vertical Polarization

- Freq.: 2457 MHz, Power Setting: 18.0 dBm, Modulation: 802.11g - 64QAM @ 54 Mbps
Trace 1: RBW= 1 MHz, VBW= 3 MHz
Trace 2: RBW= 500 kHz, VBW= 1 MHz
Trace 3: RBW= 1 MHz, VBW= 10 Hz

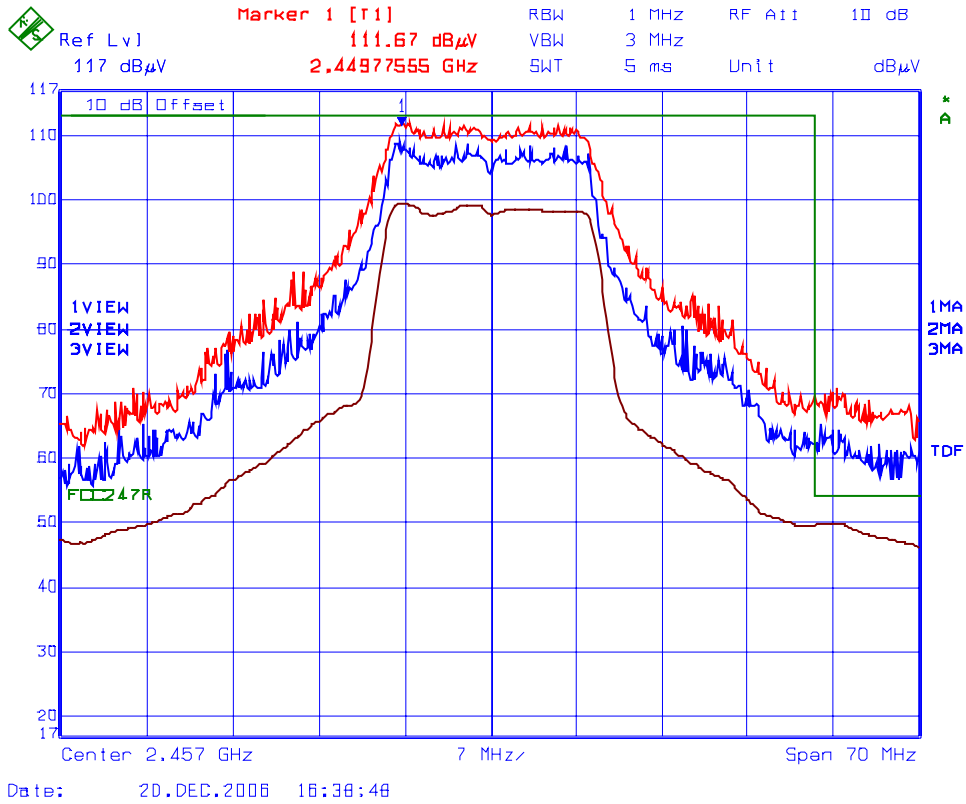

Plot 32(a): Inner Band-Edge Transmitter Radiated Emissions @ 3 Meters, Horizontal Polarization

- Freq.: 2462 MHz, Power Setting: 16.0 dBm, Modulation: 802.11g - 64QAM @ 54 Mbps
 Trace 1: RBW= 1 MHz, VBW= 3 MHz
 Trace 2: RBW= 500 kHz, VBW= 1 MHz, Delta (Peak to Band-Edge): 43.21 dB
 Trace 3: RBW= 1 MHz, VBW= 10 Hz
 Band-Edge Level at 2483.5 MHz: 115.72dBuV/m – 43.21 dB= 72.51dBuV/m (Limit 74dBuV/m)

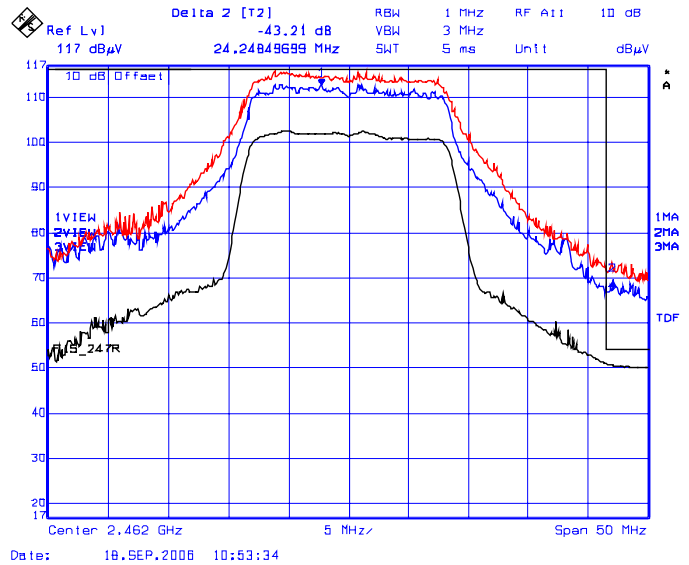
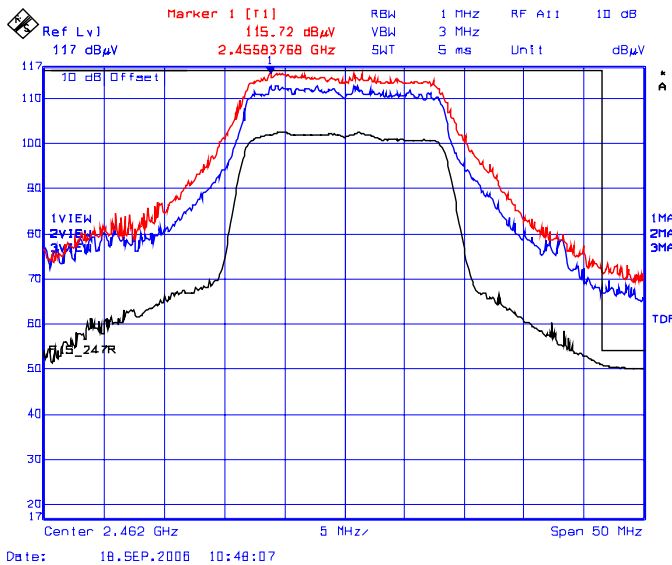

Plot 32(b): Inner Band-Edge Transmitter Radiated Emissions @ 3 Meters, Vertical Polarization

- Freq.: 2462 MHz, Power Setting: 16.0 dBm, Modulation: 802.11g - 64QAM @ 54 Mbps
 Trace 1: RBW= 1 MHz, VBW= 3 MHz
 Trace 2: RBW= 500 kHz, VBW= 1 MHz
 Trace 3: RBW= 1 MHz, VBW= 10 Hz

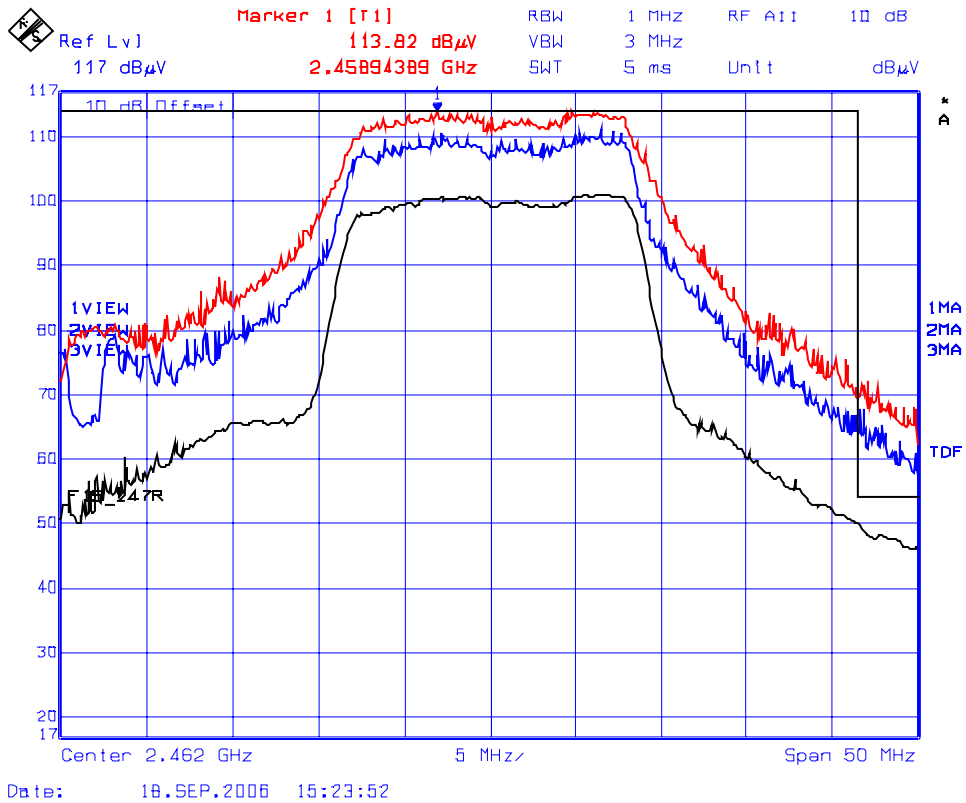

Plot 33(a): Lower Band-Edge Transmitter Radiated Emissions @ 3 Meters, Horizontal Polarization

- Freq.: 5745 MHz, Power Setting: 18.0 dBm, Modulation: 802.11a - 64QAM @ 54 Mbps
RBW= 1 MHz, VBW= 3 MHz, Peak Detector Max Hold

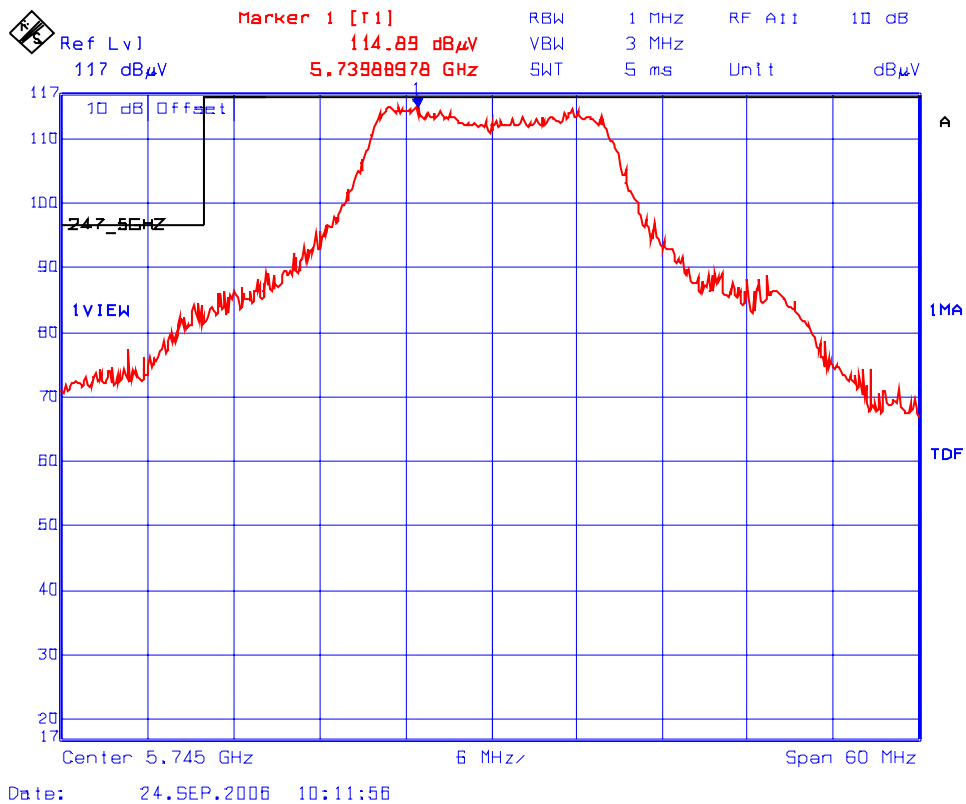

Plot 33(b): Lower Band-Edge Transmitter Radiated Emissions @ 3 Meters, Vertical Polarization

- Freq.: 5745 MHz, Power Setting: 18.0 dBm, Modulation: 802.11a - 64QAM @ 54 Mbps
RBW= 1 MHz, VBW= 3 MHz, Peak Detector Max Hold

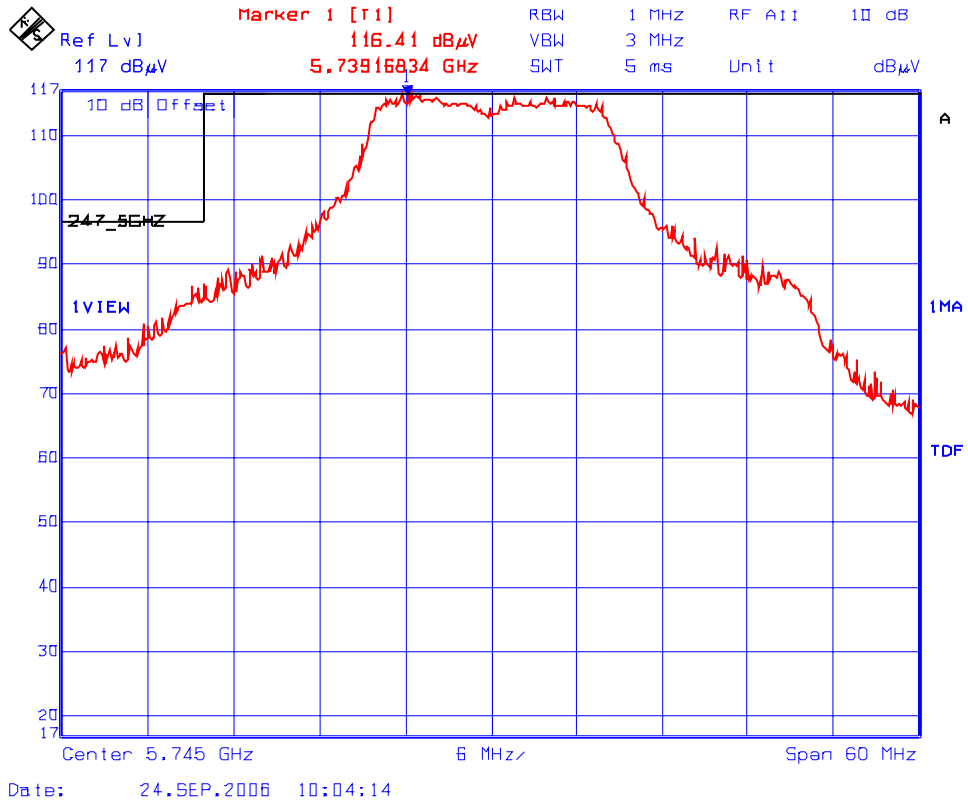

ULTRATECH GROUP OF LABS

3000 Bristol Circle, Oakville, Ontario, Canada L6H 6G4
Tel. #: 905-829-1570, Fax. #: 905-829-8050, Email: vic@ultratech-labs.com, Website: <http://www.ultratech-labs.com>

File #: CNI-080FCC15CE – 041207

Apr. 12, 2007

- All test results contained in this engineering test report are traceable to National Institute of Standards and Technology (NIST)

Plot 34(a): Upper Band-Edge Transmitter Radiated Emissions @ 3 Meters, Horizontal Polarization

- Freq.: 5825 MHz, Power Setting: 18.0 dBm, Modulation: 802.11a - 64QAM @ 54 Mbps
RBW= 1 MHz, VBW= 3 MHz, Peak Detector Max Hold

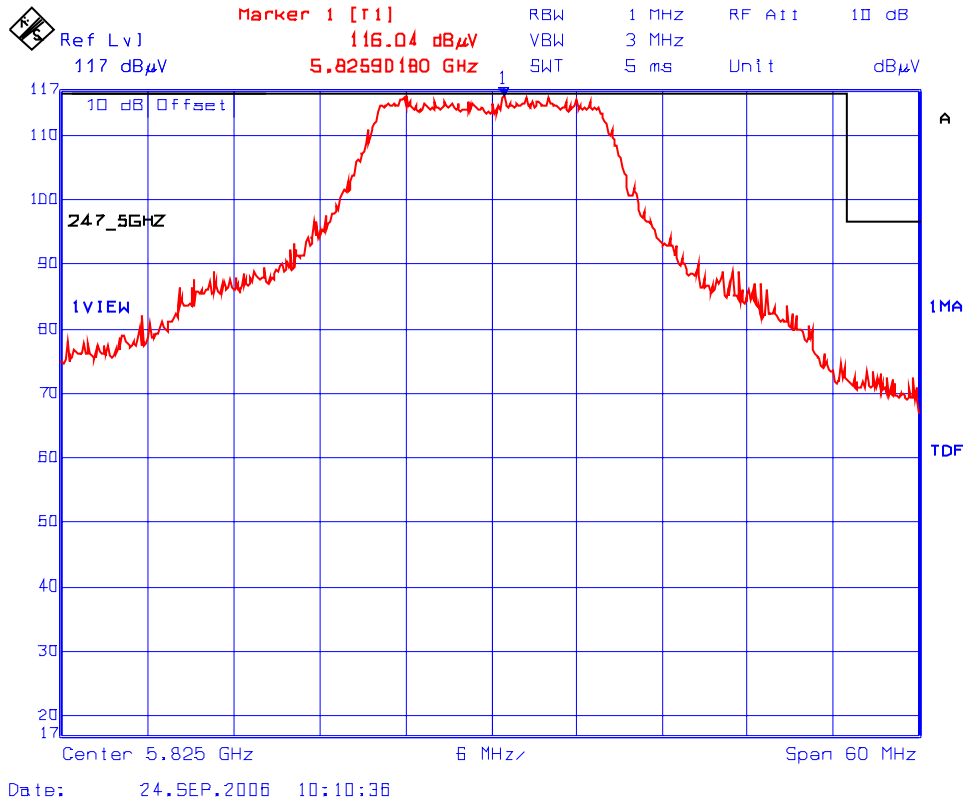

Plot 34(b): Upper Band-Edge Transmitter Radiated Emissions @ 3 Meters, Vertical Polarization

- Freq.: 5825 MHz, Power Setting: 18.0 dBm, Modulation: 802.11a - 64QAM @ 54 Mbps
RBW= 1 MHz, VBW= 3 MHz, Peak Detector Max Hold

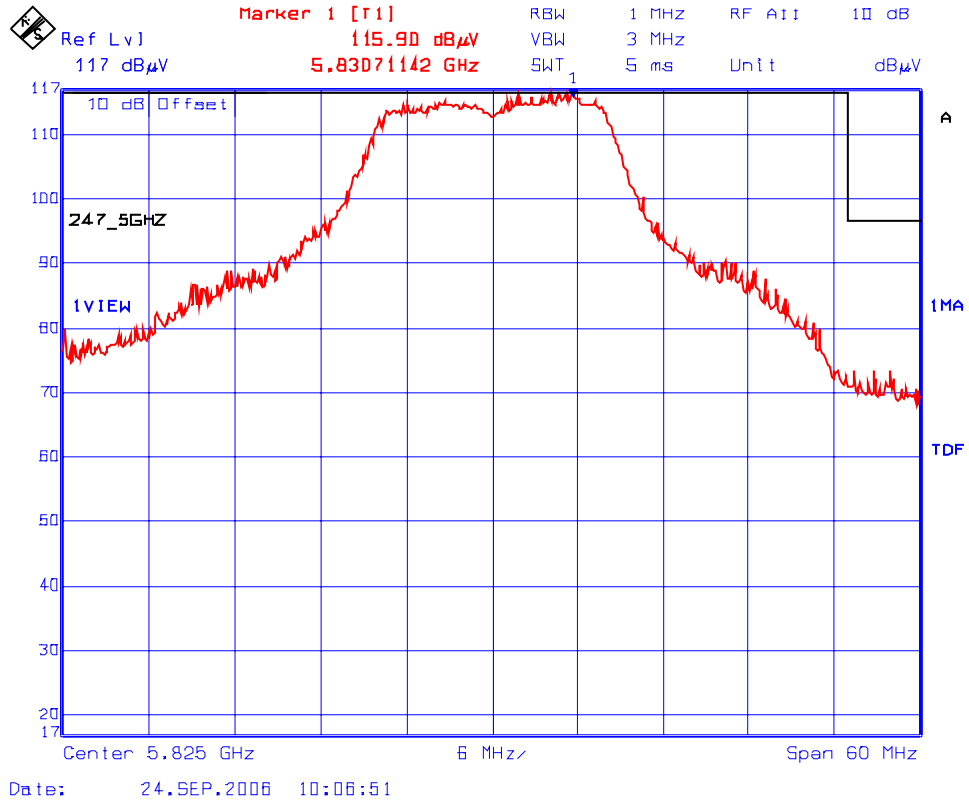

5.2.5.2. Transmitter Spurious Emissions (Radiated at 3 Meters)

5.2.5.2.1. Model ALTITUDE 350-2 DETACH 15939 with External Antenna

5.2.5.2.1.1. Operating Band: 2412-2462 MHz, Modulation: IEEE 802.11b (CCK 11 Mb/s)

Lowest Frequency (2412 MHz)

Frequency (MHz)	RF Peak Level (dBµV/m)	RF AVG Level (dBµV/m)	Antenna Plane (H/V)	Limit 15.209 (dBµV/m)	Limit 15.247 (dBµV/m)	Margin (dB)	Pass/Fail
30 – 25,000	**	**	V & H	FCC 15.209	FCC 15.247	**	Pass
The emissions were scanned from 30 MHz to 40 GHz at 3 meters distance. All radiated emissions less than 20 dB below the Limit were recorded.							

Middle Frequency (2437 MHz)

Frequency (MHz)	RF Peak Level (dBµV/m)	RF AVG Level (dBµV/m)	Antenna Plane (H/V)	Limit 15.209 (dBµV/m)	Limit 15.247 (dBµV/m)	Margin (dB)	Pass/Fail
30 – 25,000	**	**	V & H	FCC 15.209	FCC 15.247	**	Pass
The emissions were scanned from 30 MHz to 40 GHz at 3 meters distance. All radiated emissions less than 20 dB below the Limit were recorded.							

Highest Frequency (2462 MHz)

Frequency (MHz)	RF Peak Level (dBµV/m)	RF AVG Level (dBµV/m)	Antenna Plane (H/V)	Limit 15.209 (dBµV/m)	Limit 15.247 (dBµV/m)	Margin (dB)	Pass/Fail
30 – 25,000	**	**	V & H	FCC 15.209	FCC 15.247	**	Pass
The emissions were scanned from 30 MHz to 40 GHz at 3 meters distance. All radiated emissions less than 20 dB below the Limit were recorded.							

5.2.5.2.1.2. Operating Band: 2412-2462 MHz, IEEE 802.11g (64QAM @ 54Mb/s)

Lowest Frequency (2412 MHz)

Frequency (MHz)	RF Peak Level (dBµV/m)	RF AVG Level (dBµV/m)	Antenna Plane (H/V)	Limit 15.209 (dBµV/m)	Limit 15.247 (dBµV/m)	Margin (dB)	Pass/Fail
30 – 25,000	**	**	V & H	FCC 15.209	FCC 15.247	**	Pass
The emissions were scanned from 30 MHz to 40 GHz at 3 meters distance. All radiated emissions less than 20 dB below the Limit were recorded.							

Middle Frequency (2437 MHz)

Frequency (MHz)	RF Peak Level (dBµV/m)	RF AVG Level (dBµV/m)	Antenna Plane (H/V)	Limit 15.209 (dBµV/m)	Limit 15.247 (dBµV/m)	Margin (dB)	Pass/Fail
7311	62.5	43.9	V	54.0	**	-10.1	Pass
7311	63.3	45.7	H	54.0	**	-8.3	Pass
30 – 25,000	**	**	V & H	FCC 15.209	FCC 15.247	**	Pass
The emissions were scanned from 30 MHz to 25 GHz. No significant radiated emissions were found in this Frequency range (all radiated emission were found to be at least less 20 dB below the limits)							

Highest Frequency (2462 MHz)

Frequency (MHz)	RF Peak Level (dBµV/m)	RF AVG Level (dBµV/m)	Antenna Plane (H/V)	Limit 15.209 (dBµV/m)	Limit 15.247 (dBµV/m)	Margin (dB)	Pass/Fail
30 – 25,000	**	**	V & H	FCC 15.209	FCC 15.247	**	Pass
The emissions were scanned from 30 MHz to 25 GHz. No significant radiated emissions were found in this Frequency range (all radiated emission were found to be at least less 20 dB below the limits)							

5.2.5.2.1.3. Operating Band: 5745-5825 MHz, Modulation: IEEE 802.11a (64QAM @ 54Mb/s)

Lowest Frequency (5745 MHz)

Frequency (MHz)	RF Peak Level (dBµV/m)	RF AVG Level (dBµV/m)	Antenna Plane (H/V)	Limit 15.209 (dBµV/m)	Limit 15.247 (dBµV/m)	Margin (dB)	Pass/Fail
11490	63.4	50.7	V	54.0	**	-3.3	Pass
11490	63.5	50.1	H	54.0	**	-3.9	Pass
30 – 40,000	**	**	V & H	FCC 15.209	FCC 15.247	**	Pass

The emissions were scanned from 30 MHz to 40 GHz. No significant radiated emissions were found in this Frequency range (all radiated emission were found to be at least less 20 dB below the limits)

Middle Frequency (5765 MHz)

Frequency (MHz)	RF Peak Level (dBµV/m)	RF AVG Level (dBµV/m)	Antenna Plane (H/V)	Limit 15.209 (dBµV/m)	Limit 15.247 (dBµV/m)	Margin (dB)	Pass/Fail
11530	63.6	50.8	V	54.0	**	-3.2	Pass
11530	62.6	49.7	H	54.0	**	-4.3	Pass
30 – 40,000	**	**	V & H	FCC 15.209	FCC 15.247	**	Pass

The emissions were scanned from 30 MHz to 40 GHz. No significant radiated emissions were found in this Frequency range (all radiated emission were found to be at least less 20 dB below the limits)

Middle Frequency (5785 MHz)

Frequency (MHz)	RF Peak Level (dBµV/m)	RF AVG Level (dBµV/m)	Antenna Plane (H/V)	Limit 15.209 (dBµV/m)	Limit 15.247 (dBµV/m)	Margin (dB)	Pass/Fail
11570	66.3	53.2	V	54.0	**	-0.8	Pass
11570	64.8	51.5	H	54.0	**	-2.5	Pass
30 – 40,000	**	**	V & H	FCC 15.209	FCC 15.247	**	Pass

The emissions were scanned from 30 MHz to 40 GHz. No significant radiated emissions were found in this Frequency range (all radiated emission were found to be at least less 20 dB below the limits)

Middle Frequency (5805 MHz)

Frequency (MHz)	RF Peak Level (dBµV/m)	RF AVG Level (dBµV/m)	Antenna Plane (H/V)	Limit 15.209 (dBµV/m)	Limit 15.247 (dBµV/m)	Margin (dB)	Pass/Fail
11610	65.9	53.6	V	54.0	**	-0.4	Pass
11610	63.2	50.3	H	54.0	**	-3.7	Pass
30 – 40,000	**	**	V & H	FCC 15.209	FCC 15.247	**	Pass

The emissions were scanned from 30 MHz to 40 GHz. No significant radiated emissions were found in this Frequency range (all radiated emission were found to be at least less 20 dB below the limits)

Highest Frequency (5825 MHz)

Frequency (MHz)	RF Peak Level (dB μ V/m)	RF AVG Level (dB μ V/m)	Antenna Plane (H/V)	Limit 15.209 (dB μ V/m)	Limit 15.247 (dB μ V/m)	Margin (dB)	Pass/Fail
11650	64.3	51.5	V	54.0	**	-2.5	Pass
11650	62.3	50.4	H	54.0	**	-3.6	Pass
30 – 40,000	**	**	V & H	FCC 15.209	FCC 15.247	**	Pass
The emissions were scanned from 30 MHz to 40 GHz. No significant radiated emissions were found in this Frequency range (all radiated emission were found to be at least less 20 dB below the limits)							

5.2.5.2.2. Model ALTITUDE 350-2 INTEG 15938 with Internal Antenna

5.2.5.2.2.1. Operating Band: 2412-2462 MHz, Modulation: IEEE 802.11b (CCK 11 Mb/s)

Lowest Frequency (2412 MHz)

Frequency (MHz)	RF Peak Level (dBµV/m)	RF AVG Level (dBµV/m)	Antenna Plane (H/V)	Limit 15.209 (dBµV/m)	Limit 15.247 (dBµV/m)	Margin (dB)	Pass/Fail
30 – 25,000	**	**	V & H	FCC 15.209	FCC 15.247	**	Pass
The emissions were scanned from 30 MHz to 40 GHz at 3 meters distance. All radiated emissions less than 20 dB below the Limit were recorded.							

Middle Frequency (2437 MHz)

Frequency (MHz)	RF Peak Level (dBµV/m)	RF AVG Level (dBµV/m)	Antenna Plane (H/V)	Limit 15.209 (dBµV/m)	Limit 15.247 (dBµV/m)	Margin (dB)	Pass/Fail
30 – 25,000	**	**	V & H	FCC 15.209	FCC 15.247	**	Pass
The emissions were scanned from 30 MHz to 40 GHz at 3 meters distance. All radiated emissions less than 20 dB below the Limit were recorded.							

Highest Frequency (2462 MHz)

Frequency (MHz)	RF Peak Level (dBµV/m)	RF AVG Level (dBµV/m)	Antenna Plane (H/V)	Limit 15.209 (dBµV/m)	Limit 15.247 (dBµV/m)	Margin (dB)	Pass/Fail
30 – 25,000	**	**	V & H	FCC 15.209	FCC 15.247	**	Pass
The emissions were scanned from 30 MHz to 40 GHz at 3 meters distance. All radiated emissions less than 20 dB below the Limit were recorded.							

5.2.5.2.2.2. Operating Band: 2412-2462 MHz, IEEE 802.11g (64QAM @ 54Mb/s)

Lowest Frequency (2412 MHz)

Frequency (MHz)	RF Peak Level (dB μ V/m)	RF AVG Level (dB μ V/m)	Antenna Plane (H/V)	Limit 15.209 (dB μ V/m)	Limit 15.247 (dB μ V/m)	Margin (dB)	Pass/Fail
30 – 25,000	**	**	V & H	FCC 15.209	FCC 15.247	**	Pass
The emissions were scanned from 30 MHz to 40 GHz at 3 meters distance. All radiated emissions less than 20 dB below the Limit were recorded.							

Middle Frequency (2437 MHz)

Frequency (MHz)	RF Peak Level (dB μ V/m)	RF AVG Level (dB μ V/m)	Antenna Plane (H/V)	Limit 15.209 (dB μ V/m)	Limit 15.247 (dB μ V/m)	Margin (dB)	Pass/Fail
30 – 25,000	**	**	V & H	FCC 15.209	FCC 15.247	**	Pass
The emissions were scanned from 30 MHz to 40 GHz at 3 meters distance. All radiated emissions less than 20 dB below the Limit were recorded.							

Highest Frequency (2462 MHz)

Frequency (MHz)	RF Peak Level (dB μ V/m)	RF AVG Level (dB μ V/m)	Antenna Plane (H/V)	Limit 15.209 (dB μ V/m)	Limit 15.247 (dB μ V/m)	Margin (dB)	Pass/Fail
30 – 25,000	**	**	V & H	FCC 15.209	FCC 15.247	**	Pass
The emissions were scanned from 30 MHz to 25 GHz. No significant radiated emissions were found in this Frequency range (all radiated emission were found to be at least less 20 dB below the limits)							

5.2.5.2.2.3. Operating Band: 5745-5825 MHz, Modulation: IEEE 802.11a (64QAM @ 54Mb/s)

Lowest Frequency (5745 MHz)

Frequency (MHz)	RF Peak Level (dB μ V/m)	RF AVG Level (dB μ V/m)	Antenna Plane (H/V)	Limit 15.209 (dB μ V/m)	Limit 15.247 (dB μ V/m)	Margin (dB)	Pass/Fail
11490	60.6	46.1	V	54.0	--	-7.9	Pass
11490	59.2	45.7	H	54.0	--	-8.3	Pass

The emissions were scanned from 30 MHz to 25 GHz. No significant radiated emissions were found in this Frequency range (all radiated emission were found to be at least less 20 dB below the limits)

Middle Frequency (5765 MHz)

Frequency (MHz)	RF Peak Level (dB μ V/m)	RF AVG Level (dB μ V/m)	Antenna Plane (H/V)	Limit 15.209 (dB μ V/m)	Limit 15.247 (dB μ V/m)	Margin (dB)	Pass/Fail
11530	60.6	47.7	V	54.0	--	-6.3	Pass
11530	60.3	47.1	H	54.0	--	-6.9	Pass

The emissions were scanned from 30 MHz to 25 GHz. No significant radiated emissions were found in this Frequency range (all radiated emission were found to be at least less 20 dB below the limits)

Middle Frequency (5785 MHz)

Frequency (MHz)	RF Peak Level (dB μ V/m)	RF AVG Level (dB μ V/m)	Antenna Plane (H/V)	Limit 15.209 (dB μ V/m)	Limit 15.247 (dB μ V/m)	Margin (dB)	Pass/Fail
11570	63.7	49.3	V	54.0	--	-4.7	Pass
11570	63.0	49.5	H	54.0	--	-4.5	Pass

The emissions were scanned from 30 MHz to 25 GHz. No significant radiated emissions were found in this Frequency range (all radiated emission were found to be at least less 20 dB below the limits)

Middle Frequency (5805 MHz)

Frequency (MHz)	RF Peak Level (dB μ V/m)	RF AVG Level (dB μ V/m)	Antenna Plane (H/V)	Limit 15.209 (dB μ V/m)	Limit 15.247 (dB μ V/m)	Margin (dB)	Pass/Fail
11610	63.2	49.4	V	54.0	--	-4.6	Pass
11610	63.2	49.4	H	54.0	--	-4.6	Pass

The emissions were scanned from 30 MHz to 25 GHz. No significant radiated emissions were found in this Frequency range (all radiated emission were found to be at least less 20 dB below the limits)

Highest Frequency (5825 MHz)

Frequency (MHz)	RF Peak Level (dB μ V/m)	RF AVG Level (dB μ V/m)	Antenna Plane (H/V)	Limit 15.209 (dB μ V/m)	Limit 15.247 (dB μ V/m)	Margin (dB)	Pass/Fail
11650	63.8	50.5	V	54.0	--	-3.5	Pass
11650	64.1	51.6	H	54.0	--	-2.4	Pass

The emissions were scanned from 30 MHz to 25 GHz. No significant radiated emissions were found in this Frequency range (all radiated emission were found to be at least less 20 dB below the limits)

EXHIBIT 6. TEST DATA [§ 15.407 – OPERATION IN 5.15-5.35 GHz]

6.1. POWER LIMITS [§ 15.407(a)]

6.1.1. Limits

15.407(a) - Power limits:

- (1) For the band 5.15-5.25 GHz, the peak transmit power over the frequency band of operation shall not exceed the lesser of 50 mW or $4 \text{ dBm} + 10\log B$, where B is the 26-dB emission bandwidth in MHz. In addition, the peak power spectral density shall not exceed 4 dBm in any 1-MHz band. If transmitting antennas of directional gain greater than 6 dBi are used, both the peak transmit power and the peak power spectral density shall be reduced by the amount in dB that the directional gain of the antenna exceeds 6 dBi.
- (2) For the band 5.25-5.35 GHz and 5.47-5.725 GHz, the peak transmit power over the frequency band of operation shall not exceed the lesser of 250 mW or $11 \text{ dBm} + 10\log B$, where B is the 26-dB emission bandwidth in MHz. In addition, the peak power spectral density shall not exceed 11 dBm in any 1-MHz band. If transmitting antennas of directional gain greater than 6 dBi are used, both the peak transmit power and the peak power spectral density shall be reduced by the amount in dB that the directional gain of the antenna exceeds 6 dBi.

6.1.2. Method of Measurements

@ FCC § 15.407(a):

- (4) The peak transmit power must be measured over any interval of continuous transmission using instrumentation calibrated in terms of an rms-equivalent voltage. The measurement results shall be properly adjusted for any instrument limitations, such as detector response times, limited resolution bandwidth capability when compared to the emission bandwidth, sensitivity, etc., so as to obtain a true peak measurement conforming to the definitions in this paragraph for the emission in question.
- (5) The peak power spectral density is measured as a conducted emission by direct connection of a calibrated test instrument to the equipment under test. If the device cannot be connected directly, alternative techniques acceptable to the Commission may be used. Measurements are made over a bandwidth of 1 MHz or the 26 dB emission bandwidth of the device, whichever is less. A resolution bandwidth less than the measurement bandwidth can be used, provided that the measured power is integrated to show total power over the measurement bandwidth. If the resolution bandwidth is approximately equal to the measurement bandwidth, and much less than the emission bandwidth of the equipment under test, the measured results shall be corrected to account for any difference between the resolution bandwidth of the test instrument and its actual noise bandwidth.
- (6) The ratio of the peak excursion of the modulation envelope (measured using a peak hold function) to the peak transmit power (measured as specified in this paragraph) shall not exceed 13 dB across any 1 MHz bandwidth or the emission bandwidth whichever is less.

6.1.2.1. Guidelines for Emission Bandwidth "B"

Emission Bandwidth "B" MHz can be measured using a spectrum analyzer with the following setting:

- Use a RBW = 1% of the emission bandwidth.
- Set the VBW > RBW
- Use a peak detector.
- Do not use the Max Hold function. Rather, use the view button to capture the emission.
- Measure the widest width of the emission that is 26 dB down from the peak of the emission.

6.1.2.2. Guidelines for Peak Conducted Transmit Output Power

6.1.2.2.1. Peak conducted transmit output power

1. In the following, "T" is the transmission pulse duration over which the transmitter is on and transmitting at its maximum power control level.
2. Measurements are performed with a spectrum analyzer.
3. Three methods are provided to accommodate measurement limitations of the spectrum analyzer depending on signal parameters.
4. Set resolution bandwidth (RBW) = 1 MHz.
5. Set span to encompass the entire emission bandwidth (EBW) of the signal. Use automatic setting for analyzer sweep time (except in Method #2).
6. Check the sweep time to determine which procedure to use.
 - If sweep time $\leq T$, use Method #1 -- spectral trace averaging -- and sum the power across the band. Note that the hardware operation may be modified to extend the transmission time to achieve this condition for test purposes. (Method #1 may be used only if it results in averaging over intervals during which the transmitter is operating at its maximum power control level; intervals during which the transmitter is off or is transmitting at a reduced power level must not be included in the average.)
 - If sweep time $> T$, then the choice of measurement procedure will depend on the EBW of the signal.
 - If $EBW \leq$ largest available RBW on the analyzer, use Method #2--zero-span mode with trace averaging--and find the temporal peak. (Method #2 may be used only if it results in averaging over intervals during which the transmitter is operating at its maximum power control level; intervals during which the transmitter is off or is transmitting at a reduced power level must not be included in the average.)
 - If $EBW >$ largest available RBW, use Method #3--video averaging with max hold--and sum power across the band.

Method #1:

- Set span to encompass the entire emission bandwidth (EBW) of the signal.
- Set RBW = 1 MHz.
- Set VBW \geq 3 MHz.
- Use sample detector mode if bin width (i.e., span/number of points in spectrum display) $<$ 0.5 RBW. Otherwise use peak detector mode
- Use a video trigger with the trigger level set to enable triggering only on full power pulses. Transmitter must operate at full control power for entire sweep of every sweep. If the device transmits continuously, with no off intervals or reduced power intervals, the trigger may be set to "free run".
- Trace average 100 traces in power averaging mode.

- Compute power by integrating the spectrum across the 26 dB EBW of the signal. The integration can be performed using the spectrum analyzer's band power measurement function with band limits set equal to the EBW band edges or by summing power levels in each 1 MHz band in linear power terms. The 1 MHz band power levels to be summed can be obtained by averaging, in linear power terms, power levels in each frequency bin across the 1 MHz.

Method #2:

- Set zero span mode. Set center frequency to the midpoint between the -26 dB points of the signal.
- Set $RBW \geq EBW$.
- Set $VBW \geq 3 RBW$. [If $VBW \geq 3 RBW$ is not available, use highest available VBW, but VBW must be $\geq RBW$]
- Set sweep time = T
- Use sample detector mode.
- Use a video trigger with the trigger level set to enable triggering only on full power pulses.
- Trace average 100 traces in power averaging mode.
- Find the peak of the resulting average trace.

Method #3:

- Set span to encompass the entire emission bandwidth (EBW) of the signal.
- Set sweep trigger to "free run".
- Set $RBW = 1 \text{ MHz}$. Set $VBW \geq 1/T$
- Use linear display mode.
- Use sample detector mode if bin width (i.e., span/number of points in spectrum) $< 0.5 RBW$. Otherwise use peak detector mode.
- Set max hold.
- Allow max hold to run for 60 seconds.
- Compute power by integrating the spectrum across the 26 dB EBW or apply a bandwidth correction factor of $10 \log(EBW/1 \text{ MHz})$ to the spectral peak of the emission. The integration can be performed using the spectrum analyzer's band power measurement function with band limits set equal to the EBW band edges or by summing power levels in each 1 MHz band in linear power terms. The 1 MHz band power levels to be summed can be obtained by averaging, in linear power terms, power levels in each frequency bin across the 1 MHz.

Emission bandwidth "B" MHz:

- Use a $RBW =$ approximately 1% of the emission bandwidth.
- Set the $VBW > RBW$
- Use a peak detector.
- Do not use the Max Hold function. Rather, use the view button to capture the emission.
- Measure the maximum width of the emission that is 26 dB down from the peak of the emission. Compare this with the RBW setting of the analyzer. Readjust RBW and repeat measurement as needed until the RBW/EBW ratio is approximately 1%.

Peak Power Spectral Density (PPSD):

This is an antenna conducted measurement using a spectrum analyzer. Method #2 provides the most accurate implementation of the rule; however, equipment limitations may preclude its use for short pulses. Method #1 is also acceptable to show compliance; it may overestimate the PPSD, but is easier to implement than method #2, and must be used when the conditions of method #2 cannot be achieved.

Method 1:

Use peak detector mode and max hold. Set RBW= 1MHz* and VBW > 1 MHz. The PPSD is the highest level found across the emission in any 1-MHz band.

Method 2:

Use sample detector and power averaging (not video averaging) mode. Set RBW= 1 MHz*, VBW > 1 MHz. The PPSD is the highest level found across the emission in any 1-MHz band after 100 sweeps of averaging. This method is permitted only if the transmission pulse or sequence of pulses remains at maximum transmit power throughout each of the 100 sweeps of averaging and that the interval between pulses is not included in any of the sweeps (e.g., 100 sweeps should occur during one transmission, or each sweep gated to occur during a transmission).

- When the emission bandwidth is less than 1 MHz, use a measurement bandwidth equal to the emission bandwidth, in accordance with Section 15.407(a)(5).
- It is permissible to use a resolution bandwidth less than the measurement bandwidth provided the measured power is integrated to show total power over the measurement bandwidth. The integration can be performed using the spectrum analyzer’s band power measurement function with band limits set equal to the measurement band edges or by summing power levels in each band in linear power terms.

Peak Excursion Measurement:

Set the spectrum analyzer span to view the entire emission bandwidth. The largest difference between the following two traces must be ≤ 13 dB for all frequencies across the emission bandwidth. Submit a plot.

- 1st Trace: Set RBW = 1 MHz, VBW ≥ 3 MHz with peak detector and Maxhold settings.
- 2nd Trace: If Method #1 was used for the peak conducted transmit output power test, then create the 2nd trace using the settings described in Method #1.
- If Methods #2 or #3 were used for the peak conducted transmit power test, then create the 2nd trace using the setting described in Method #3.

6.1.3. Test Arrangement

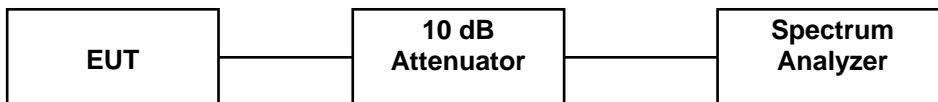

6.1.4. Test Equipment List

Test Instruments	Manufacturer	Model No.	Serial No.	Frequency Range
Spectrum Analyzer	Rohde & Schwarz	FSEK20/B4/B21	834157/005	9 kHz – 40 GHz

6.1.5. Test Data

6.1.5.1. Peak Power Spectral Density (PPSD) In 1 MHz BW

Remarks: The measurements for PPSD are not required to be repeated based on the nature of modifications as described in Section 1.1 of this test report. Only the transmit power are required to be tested to ensure the transmitter operates at it’s maximum output power for transmitter radiated spurious/harmonic measurements.

6.1.5.2. Maximum Conducted Transmit Power (Full Bandwidth) for Model ALTITUDE 350-2 DETACH 15939 with External Antenna

Remarks: Test Method used: Test Method #1 using Sample Detector

6.1.5.2.1. For 5150-5250 MHz band

Frequency (MHz)	Power Setting (dBm)	Modulation 802.11a	Measured Channel Power in 26 dB BW (dBm)	Limit (dBm)
5180	20	64QAM @ 54 Mbps	15.0	17
5220	20	64QAM @ 54 Mbps	14.9	17
5240	20	64QAM @ 54 Mbps	14.7	17

Refer to Plots # 35 to 37

6.1.5.2.2. For 5250-5350 MHz Band

Frequency (MHz)	Power Setting (dBm)	Modulation 802.11a	Measured Channel Power in 26 dB BW (dBm)	Limit (dBm)
5260	20	64QAM @ 54 Mbps	15.0	24.0
5300	20	64QAM @ 54 Mbps	14.7	24.0
5320	20	64QAM @ 54 Mbps	14.2	24.0

Refer to Plots # 38 to 40

Plot #35: Channel Conducted Power in 26 dB Bandwidth
 Power Setting 20 dBm, Test Method #1: Sample Detector
 Channel 36: 5180 MHz, Modulation: 802.11a - 64 QAM (54 Mbps)

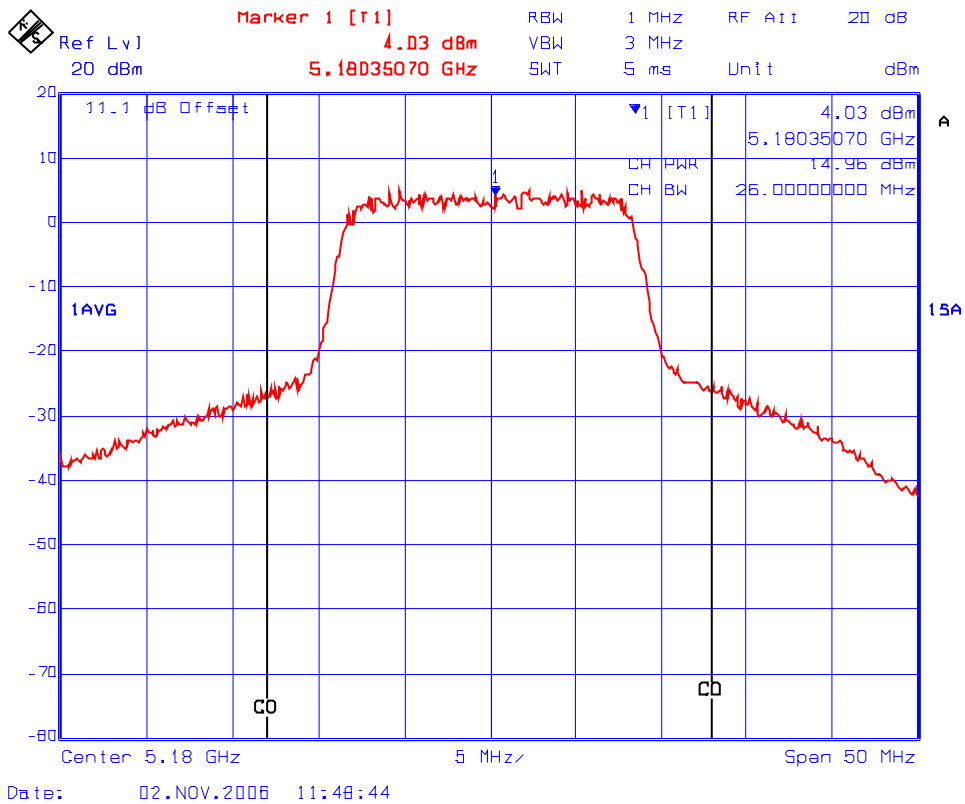

ULTRATECH GROUP OF LABS

3000 Bristol Circle, Oakville, Ontario, Canada L6H 6G4
 Tel. #: 905-829-1570, Fax. #: 905-829-8050, Email: vic@ultratech-labs.com, Website: <http://www.ultratech-labs.com>

File #: CNI-080FCC15CE – 041207

Apr. 12, 2007

- All test results contained in this engineering test report are traceable to National Institute of Standards and Technology (NIST)

Plot #36: Channel Conducted Power in 26 dB Bandwidth
Power Setting 20 dBm, Test Method #1: Sample Detector
Channel 44: 5220 MHz, Modulation: 802.11a - 64 QAM (54 Mbps)

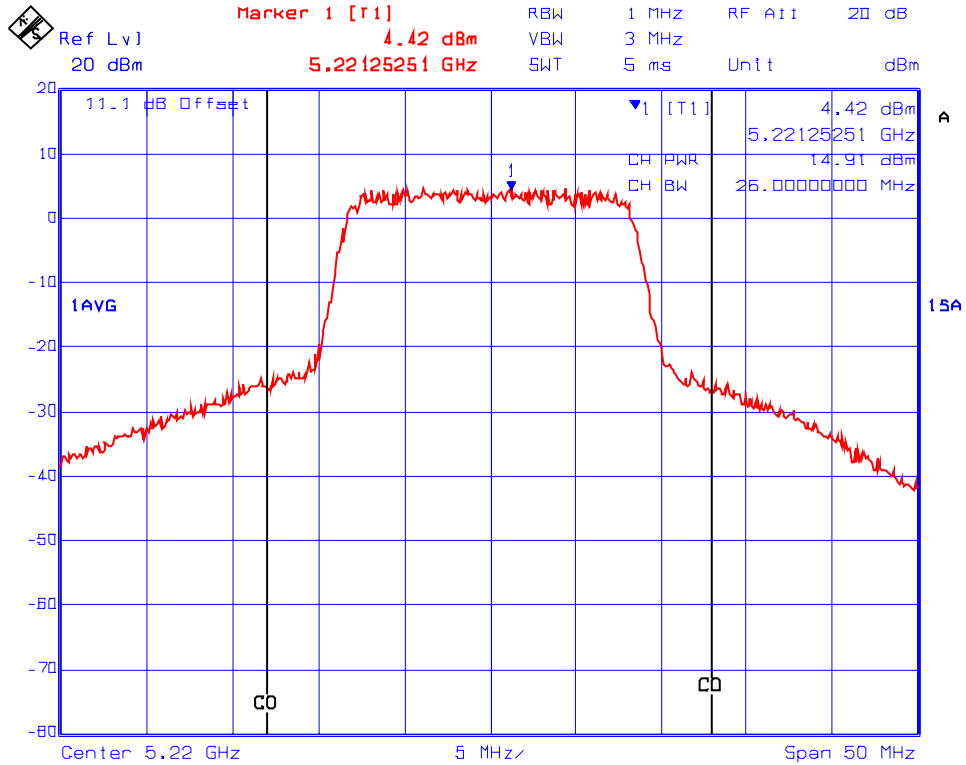

Date: 02.NOV.2006 11:50:13

ULTRATECH GROUP OF LABS

3000 Bristol Circle, Oakville, Ontario, Canada L6H 6G4
Tel. #: 905-829-1570, Fax. #: 905-829-8050, Email: vic@ultratech-labs.com, Website: <http://www.ultratech-labs.com>

File #: CNI-080FCC15CE – 041207

Apr. 12, 2007

- All test results contained in this engineering test report are traceable to National Institute of Standards and Technology (NIST)

Plot #37: Channel Conducted Power in 26 dB Bandwidth
Power Setting 20 dBm, Test Method #1: Sample Detector
Channel 48: 5240 MHz, Modulation: 802.11a - 64 QAM (54 Mbps)

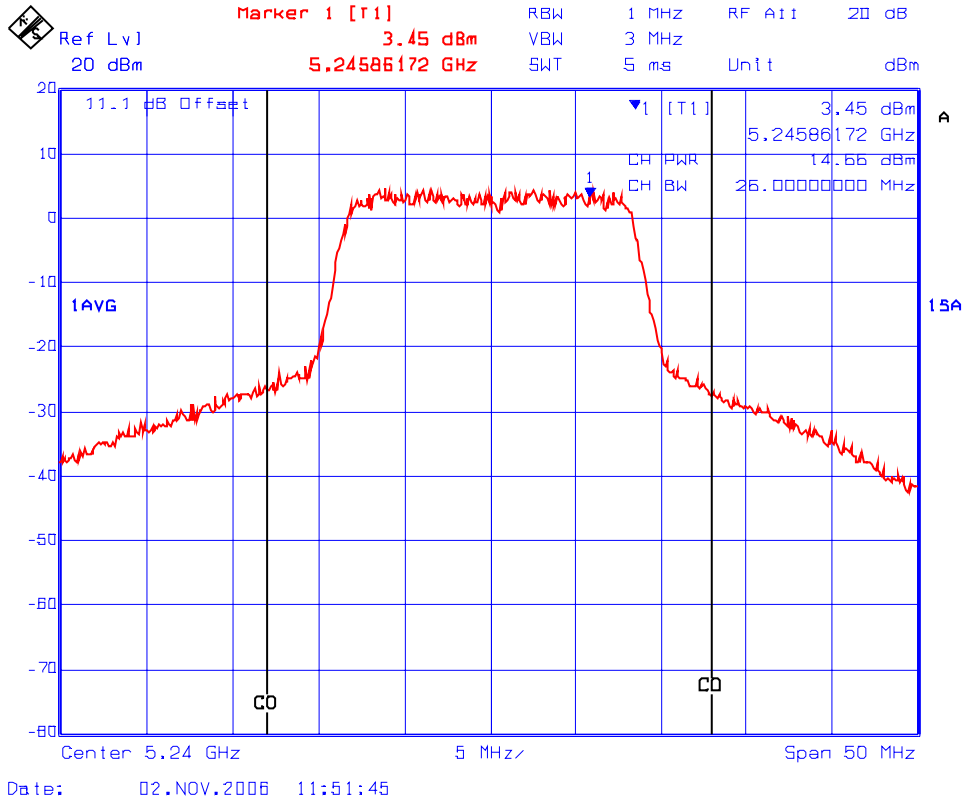

ULTRATECH GROUP OF LABS

3000 Bristol Circle, Oakville, Ontario, Canada L6H 6G4
Tel. #: 905-829-1570, Fax. #: 905-829-8050, Email: vic@ultratech-labs.com, Website: <http://www.ultratech-labs.com>

File #: CNI-080FCC15CE – 041207

Apr. 12, 2007

- All test results contained in this engineering test report are traceable to National Institute of Standards and Technology (NIST)

Plot #38: Channel Conducted Power in 26 dB Bandwidth
Power Setting 20 dBm, Test Method #1: Sample Detector
Channel 52: 5260 MHz, Modulation: 802.11a - 64 QAM (54 Mbps)

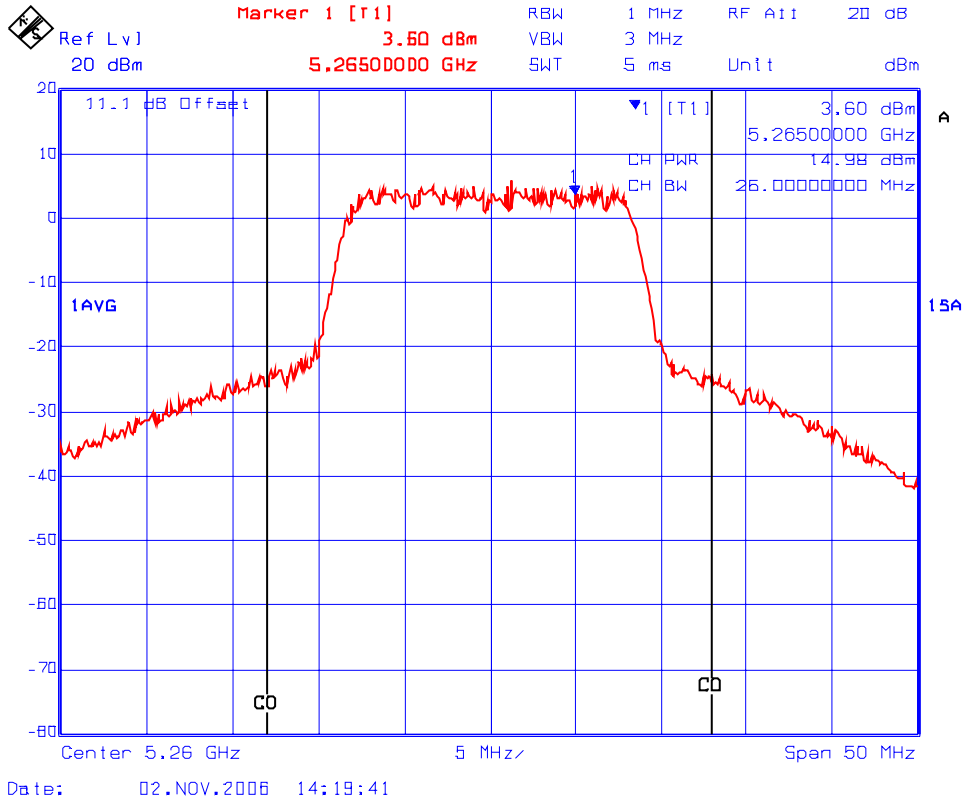

ULTRATECH GROUP OF LABS

3000 Bristol Circle, Oakville, Ontario, Canada L6H 6G4
Tel. #: 905-829-1570, Fax. #: 905-829-8050, Email: vic@ultratech-labs.com, Website: <http://www.ultratech-labs.com>

File #: CNI-080FCC15CE – 041207

Apr. 12, 2007

- All test results contained in this engineering test report are traceable to National Institute of Standards and Technology (NIST)

Plot #39: Channel Conducted Power in 26 dB Bandwidth
Power Setting 20 dBm, Test Method #1: Sample Detector
Channel 60: 5300 MHz, Modulation: 802.11a - 64 QAM (54 Mbps)

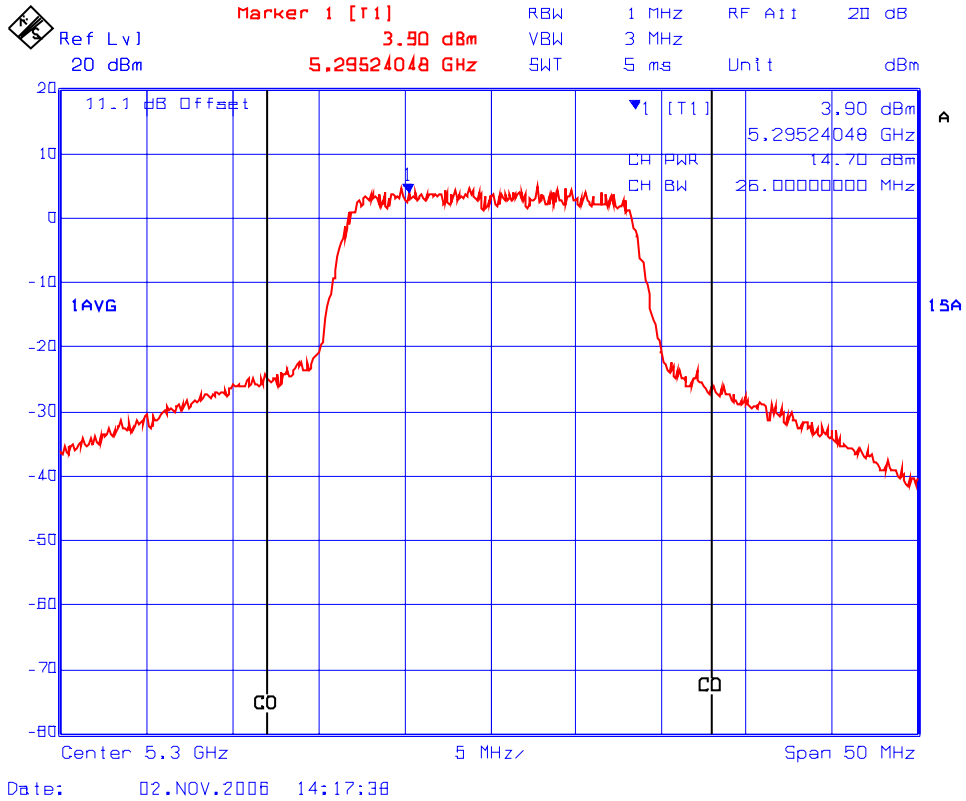

ULTRATECH GROUP OF LABS

3000 Bristol Circle, Oakville, Ontario, Canada L6H 6G4
Tel. #: 905-829-1570, Fax. #: 905-829-8050, Email: vic@ultratech-labs.com, Website: <http://www.ultratech-labs.com>

File #: CNI-080FCC15CE – 041207

Apr. 12, 2007

- All test results contained in this engineering test report are traceable to National Institute of Standards and Technology (NIST)

Plot #40: Channel Conducted Power in 26 dB Bandwidth
 Power Setting 20 dBm, Test Method #1: Sample Detector
 Channel 64: 5320 MHz, Modulation: 802.11a - 64 QAM (54 Mbps)

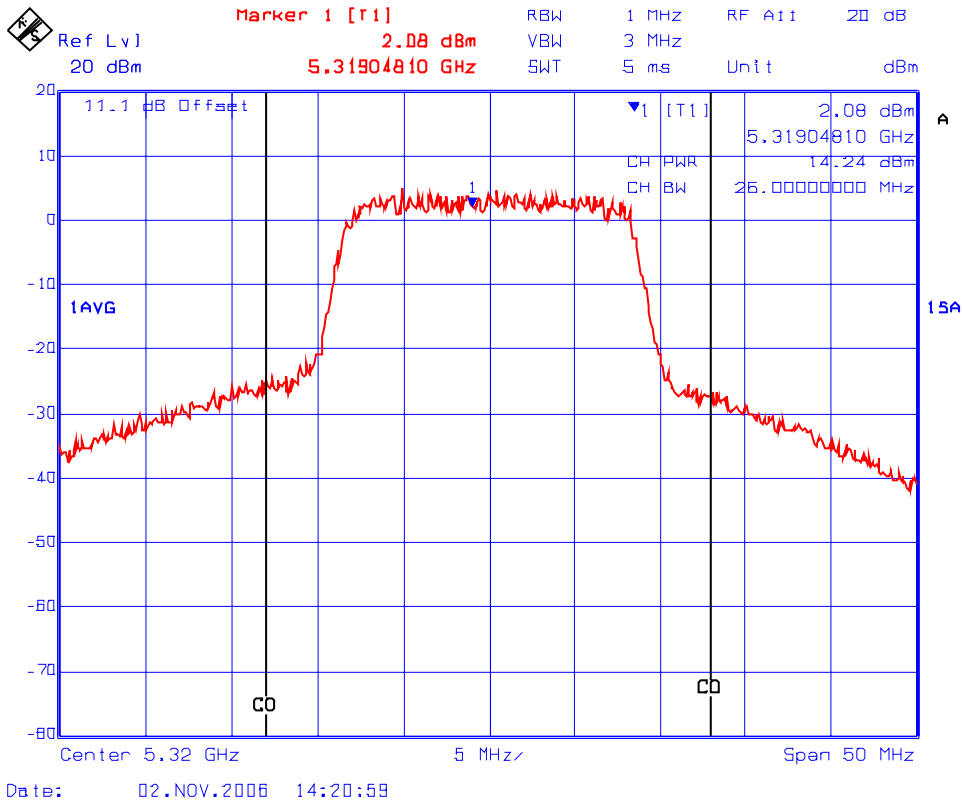

ULTRATECH GROUP OF LABS

3000 Bristol Circle, Oakville, Ontario, Canada L6H 6G4
 Tel. #: 905-829-1570, Fax. #: 905-829-8050, Email: vic@ultratech-labs.com, Website: <http://www.ultratech-labs.com>

File #: CNI-080FCC15CE – 041207

Apr. 12, 2007

- All test results contained in this engineering test report are traceable to National Institute of Standards and Technology (NIST)

6.1.5.3. Maximum Conducted Transmit Power (Full Bandwidth) for Model ALTITUDE 350-2 INTEG 15938 with Internal Antenna

Remarks: Test Method used: Test Method #1 using Sample Detector

6.1.5.3.1. For 5150-5250 MHz band

Frequency (MHz)	Power Setting (dBm)	Modulation 802.11a	Measured Channel Power in 26 dB BW (dBm)	Limit (dBm)
5180	17	64QAM @ 54Mb/s	14.1	17.0
5220	17	64QAM @ 54Mb/s	14.4	17.0
5240	17	64QAM @ 54Mb/s	14.3	17.0

Refer to Plots # 41 to 43

6.1.5.3.2. For 5250-5350 MHz Band

Frequency (MHz)	Power Setting (dBm)	Modulation 802.11a	Measured Channel Power in 26 dB BW (dBm)	Limit (dBm)
5260	18	64QAM @ 54 Mbps	14.6	24.0
5300	18	64QAM @ 54 Mbps	14.7	24.0
5320	18	64QAM @ 54 Mbps	14.8	24.0

Refer to Plots # 44 to 46

Plot #41: Channel Conducted Power in 26 dB Bandwidth
Power Setting 17 dBm, Test Method #1: Sample Detector
Channel 36: 5180 MHz, Modulation: 802.11a - 64 QAM (54 Mbps)

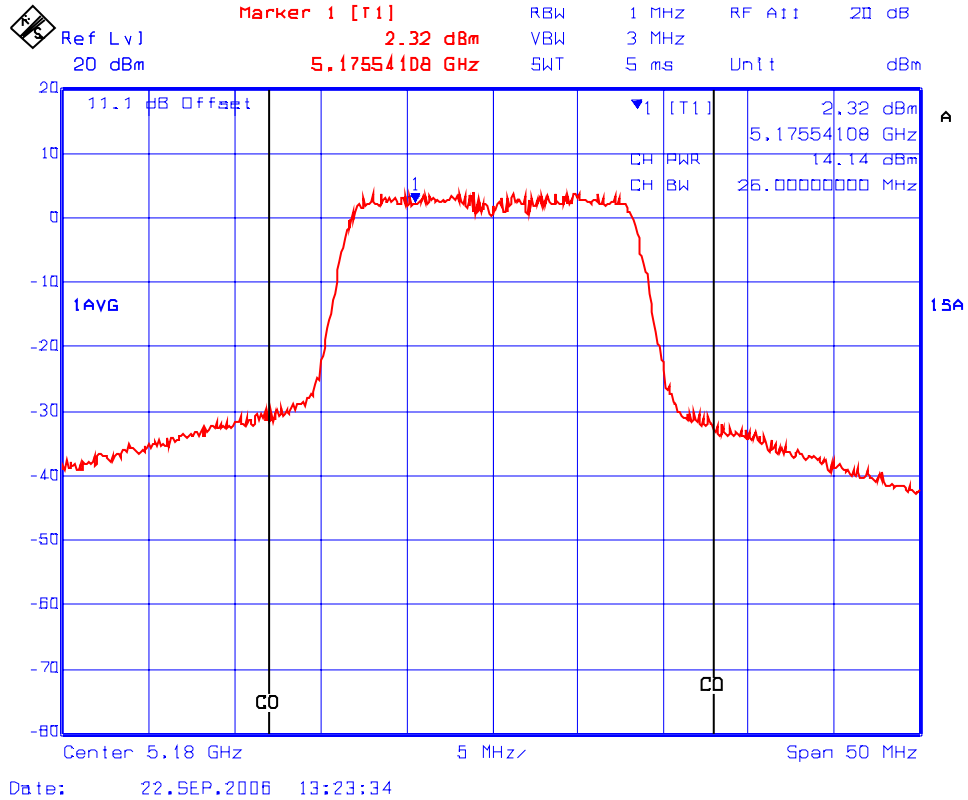

ULTRATECH GROUP OF LABS

3000 Bristol Circle, Oakville, Ontario, Canada L6H 6G4
Tel. #: 905-829-1570, Fax. #: 905-829-8050, Email: vic@ultratech-labs.com, Website: <http://www.ultratech-labs.com>

File #: CNI-080FCC15CE – 041207

Apr. 12, 2007

- All test results contained in this engineering test report are traceable to National Institute of Standards and Technology (NIST)

Plot #42: Channel Conducted Power in 26 dB Bandwidth
 Power Setting 17 dBm, Test Method #1: Sample Detector
 Channel 44: 5220 MHz, Modulation: 802.11a - 64 QAM (54 Mbps)

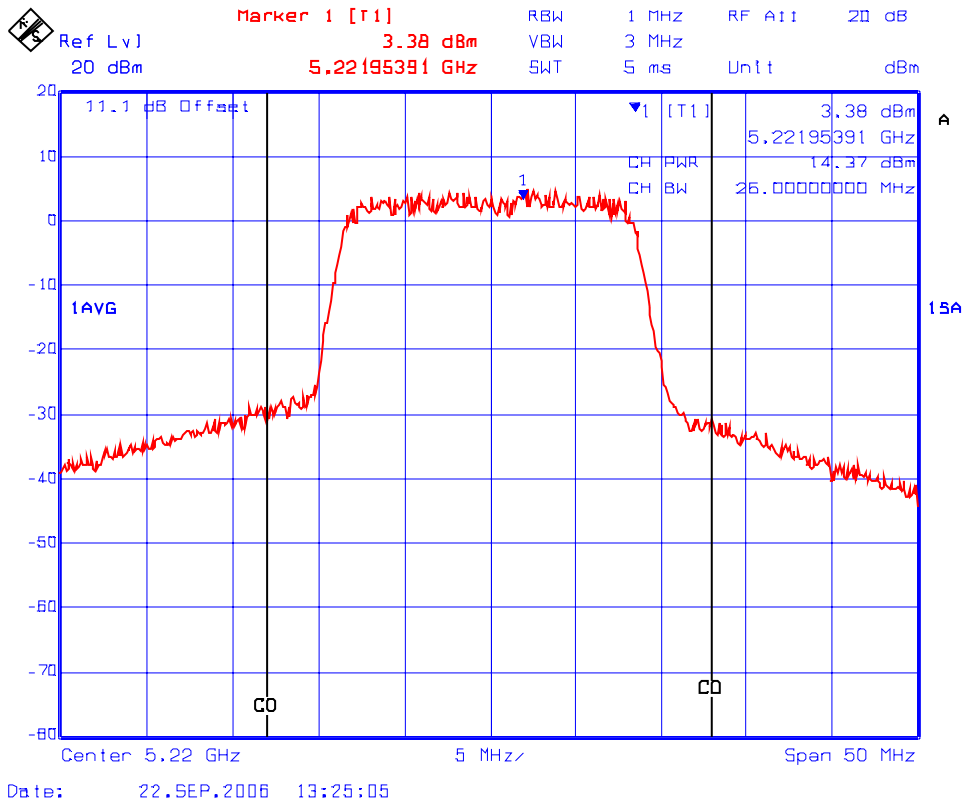

ULTRATECH GROUP OF LABS

3000 Bristol Circle, Oakville, Ontario, Canada L6H 6G4
 Tel. #: 905-829-1570, Fax. #: 905-829-8050, Email: vic@ultratech-labs.com, Website: <http://www.ultratech-labs.com>

File #: CNI-080FCC15CE – 041207

Apr. 12, 2007

- All test results contained in this engineering test report are traceable to National Institute of Standards and Technology (NIST)

Plot #43: Channel Conducted Power in 26 dB Bandwidth
 Power Setting 17 dBm, Test Method #1: Sample Detector
 Channel 48: 5240 MHz, Modulation: 802.11a - 64 QAM (54 Mbps)

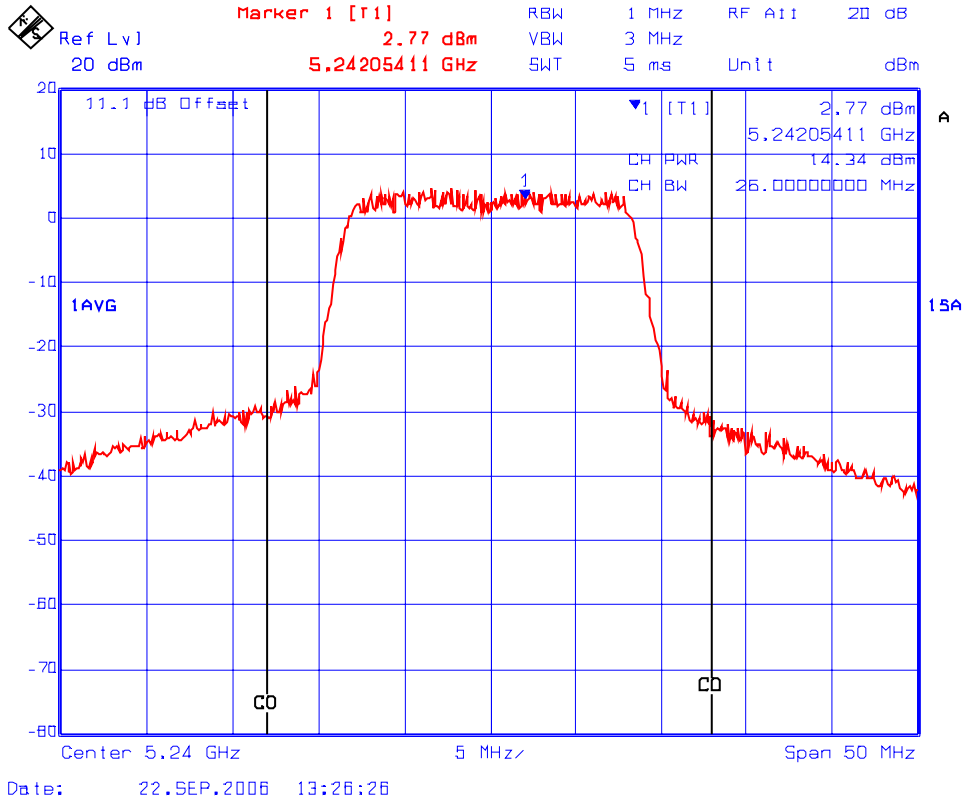

Plot #44: Channel Conducted Power in 26 dB Bandwidth
Power Setting 18 dBm, Test Method #1: Sample Detector
Channel 52: 5260 MHz, Modulation: 802.11a - 64 QAM (54 Mbps)

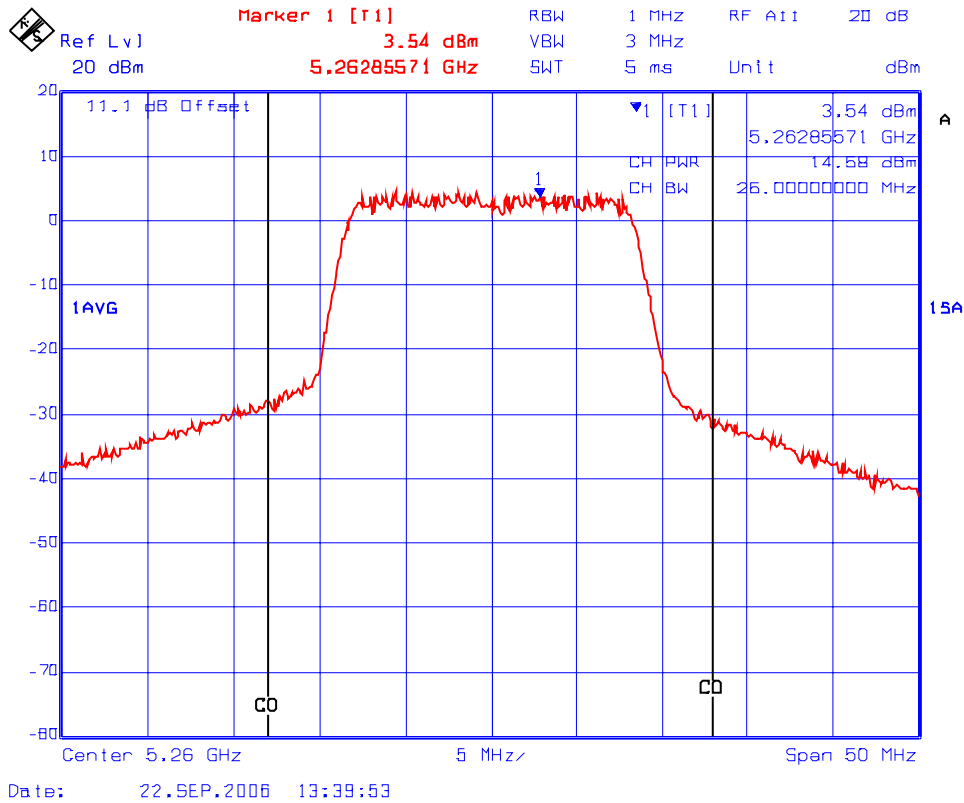

ULTRATECH GROUP OF LABS

3000 Bristol Circle, Oakville, Ontario, Canada L6H 6G4
Tel. #: 905-829-1570, Fax. #: 905-829-8050, Email: vic@ultratech-labs.com, Website: <http://www.ultratech-labs.com>

File #: CNI-080FCC15CE – 041207

Apr. 12, 2007

- All test results contained in this engineering test report are traceable to National Institute of Standards and Technology (NIST)

Plot #45: Channel Conducted Power in 26 dB Bandwidth
Power Setting 18 dBm, Test Method #1: Sample Detector
Channel 60: 5300 MHz, Modulation: 802.11a - 64 QAM (54 Mbps)

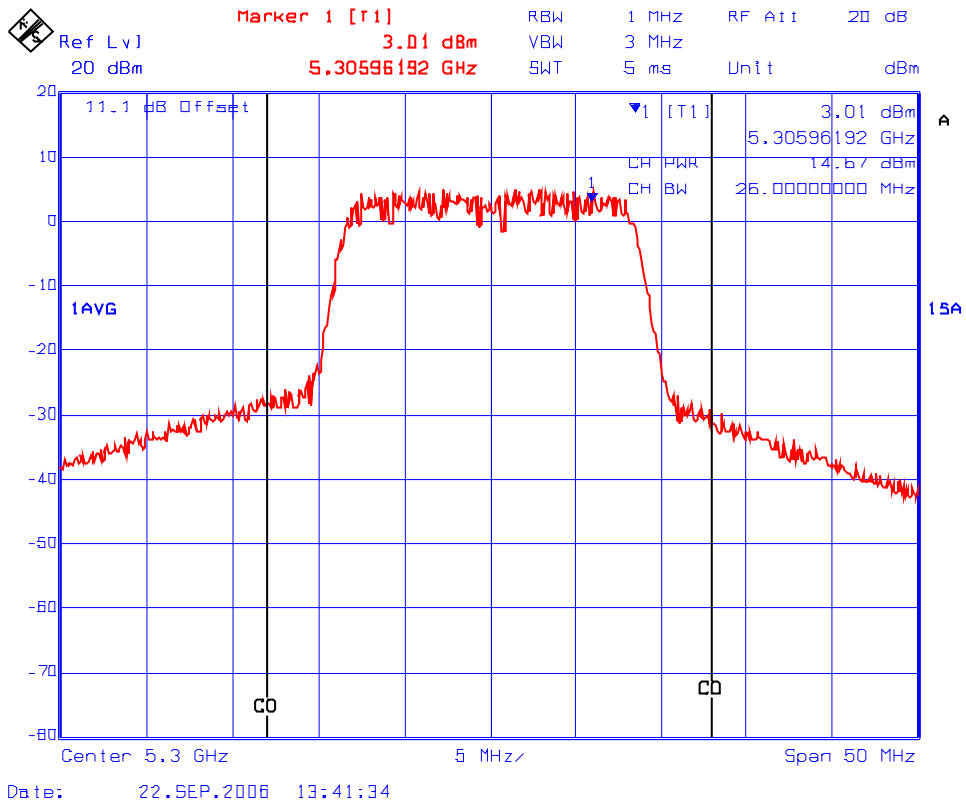

ULTRATECH GROUP OF LABS

3000 Bristol Circle, Oakville, Ontario, Canada L6H 6G4
Tel. #: 905-829-1570, Fax. #: 905-829-8050, Email: vic@ultratech-labs.com, Website: <http://www.ultratech-labs.com>

File #: CNI-080FCC15CE – 041207

Apr. 12, 2007

- All test results contained in this engineering test report are traceable to National Institute of Standards and Technology (NIST)

Plot #46: Channel Conducted Power in 26 dB Bandwidth
 Power Setting 18 dBm, Test Method #1: Sample Detector
 Channel 64: 5320 MHz, Modulation: 802.11a - 64 QAM (54 Mbps)

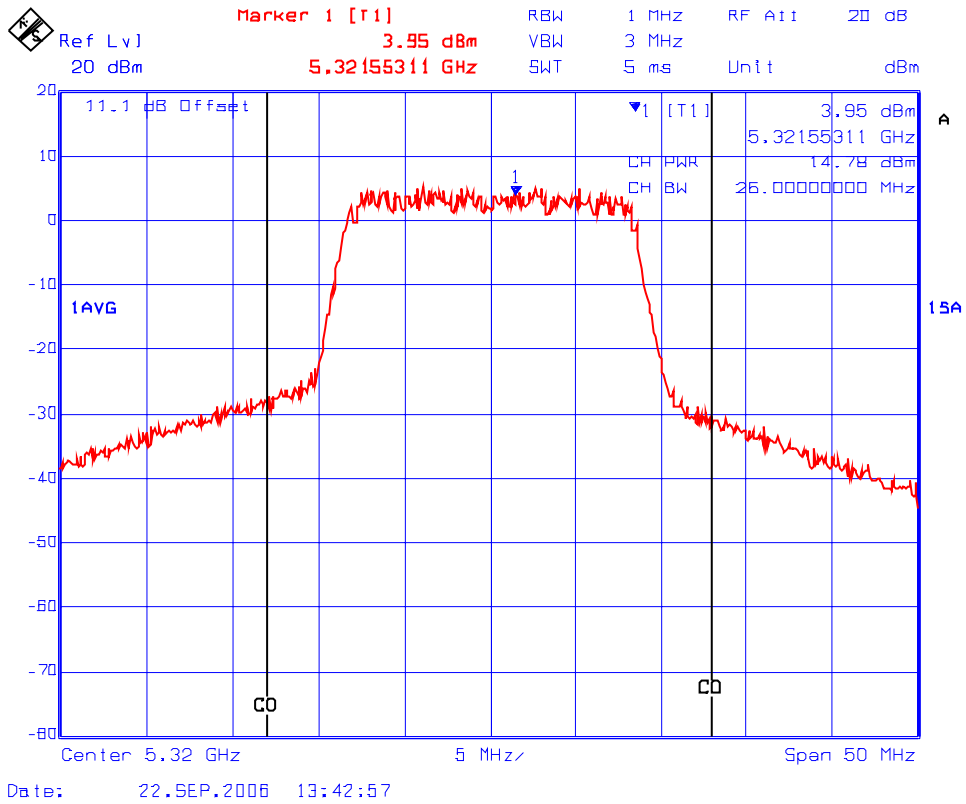

ULTRATECH GROUP OF LABS

3000 Bristol Circle, Oakville, Ontario, Canada L6H 6G4
 Tel. #: 905-829-1570, Fax. #: 905-829-8050, Email: vic@ultratech-labs.com, Website: <http://www.ultratech-labs.com>

File #: CNI-080FCC15CE – 041207

Apr. 12, 2007

- All test results contained in this engineering test report are traceable to National Institute of Standards and Technology (NIST)

6.2. UNDESIRE EMISSIONS (RADIATED @ 3 METERS) [§ 15.407(b)]

6.2.1. Limits

Undesirable emission limits: the PEAK emissions outside of the frequency bands of operation shall be attenuated in accordance with the following limits:

- (1) For transmitters operating in the 5.15-5.25 GHz band: all emissions outside of the 5.15-5.25 GHz, 5.25-5.35 GHz and band shall not exceed an EIRP of -27 dBm/MHz.
- (2) For transmitters operating in the 5.25-5.35 GHz band: all emissions outside of the 5.15-5.25 GHz, 5.25-5.35 GHz and band shall not exceed an EIRP of -27 dBm/MHz. Devices operating in the 5.25-5.35 GHz band that generate emissions in the 5.15-5.25 GHz band must meet all applicable technical requirements for operation in the 5.15-5.25 GHz band (including indoor use) or alternatively meet an out-of-band emission EIRP limit of -27 dBm/MHz in the 5.15-5.25 GHz band.
- (3) For transmitters operating in the 5.47-5.725 GHz band: all emissions outside of the 5.47-5.725 GHz band shall not exceed an EIRP of -27 dBm/MHz.
- (4) For transmitters operating in the 5.725-5.850 GHz band: all emissions within the frequency range from the band edge to 10 MHz above or below the band edge shall not exceed an EIRP of -17 dBm/MHz; for frequencies 10 MHz or greater above or below the band edge, emissions shall not exceed an EIRP of -27 dBm/MHz.
- (5) The emission measurements shall be performed using a minimum resolution bandwidth of 1 MHz. A lower resolution bandwidth may be employed near the band edge, when necessary, provided the measured energy is integrated to show the total power over 1 MHz.
- (6) Unwanted emissions below 1 GHz must comply with the general field strength limits set forth in Sec. 15.209.
- (7) The provisions of Sec. 15.205 apply to intentional radiators operating under this section. (7) When measuring the emission limits, the nominal carrier frequency shall be adjusted as close to the upper and lower frequency block edges as the design of the equipment permits.

Remarks:

FCC 47 CFR § 5.205(a) - Restricted Frequency Bands

MHz	MHz	MHz	GHz
0.090 - 0.110	162.0125 - 167.17	2310 - 2390	9.3 - 9.5
0.49 - 0.51	167.72 - 173.2	2483.5 - 2500	10.6 - 12.7
2.1735 - 2.1905	240 - 285	2655 - 2900	13.25 - 13.4
8.362 - 8.366	322 - 335.4	3260 - 3267	14.47 - 14.5
13.36 - 13.41	399.9 - 410	3332 - 3339	14.35 - 16.2
25.5 - 25.67	608 - 614	3345.8 - 3358	17.7 - 21.4
37.5 - 38.25	960 - 1240	3600 - 4400	22.01 - 23.12
73 - 75.4	1300 - 1427	4500 - 5250	23.6 - 24.0
108 - 121.94	1435 - 1626.5	5350 - 5460	31.2 - 31.8
123 - 138	1660 - 1710	7250 - 7750	36.43 - 36.5
149.9 - 150.05	1718.8 - 1722.2	8025 - 8500	Above 38.6
156.7 - 156.9	2200 - 2300	9000 - 9200	

FCC 47 CFR § 15.209(a)
-- Field Strength Limits within Restricted Frequency Bands --

FREQUENCY (MHz)	FIELD STRENGTH LIMITS (microvolts/m)	DISTANCE (Meters)
0.009 - 0.490	2,400 / F (KHz)	300
0.490 - 1.705	24,000 / F (KHz)	30
1.705 - 30.0	30	30
30 – 88	100	3
88 – 216	150	3
216 – 960	200	3
Above 960	500	3

6.2.2. Method of Measurements

Refer to Exhibit 8 Section 8.2 of this test report and ANSI 63.4 for detailed radiated emissions measurement procedures.

The following measurement procedures were also applied:

- Applies to harmonics/spurious that fall in the restricted bands listed in Section 15.205. the maximum permitted average field strength is listed in Section 15.209. A Pre-Amp and highpass filter are used for this measurement.
- For measurement below 1 GHz, set RBW = 100 KHz, VBW ≥ 100 KHz, SWEEP=AUTO.
- For measurement above 1 GHz, set RBW = 1 MHz, VBW = 1 MHz (Peak), SWEEP=AUTO.

6.2.3. Test Arrangement

Please refer to Test Arrangement in Section 2.6 for details of test setup for emission measurements.

6.2.4. Test Equipment List

Test Instruments	Manufacturer	Model No.	Serial No.	Frequency Range
Spectrum Analyzer	Rohde & Schwarz	FSEK20/B4/B21	834157/005	9 kHz – 40 GHz
Microwave Amplifier	Hewlett Packard	HP 83017A		1 GHz to 26.5 GHz
Biconilog Antenna	EMCO	3143	1029	20 MHz to 2 GHz
Horn Antenna	EMCO	3155	9701-5061	1 GHz – 18 GHz
Horn Antenna	EMCO	3160-09	..	18 GHz – 26.5 GHz
Horn Antenna	EMCO	3160-10	..	26.5 GHz – 40 GHz
Mixer	Tektronix	118-0098-00	..	18 GHz – 26.5 GHz
Mixer	Tektronix	119-0098-00	..	26.5 GHz – 40 GHz

6.2.5. Photographs Test Setup

Please refer to Photos # 1 to 6 in Annex 1 for details of test setup for radiated emissions measurements

6.2.6. Test Data

Theory of Conversion From EIRP Limits to E-Field Limits:

FCC specifies the limit of an EIRP of -17 dBm/MHz; for frequencies 10 MHz or greater above or below the band edge, and an EIRP of -27 dBm/MHz. For other emissions outside 5.725 GHz - 10 MHz and 5.825 GHz + 10 MHz. In addition, the FCC E-Field Limits @ 15.209 in dBuV/m are applied for spurious and harmonic emissions which fall in the restricted band specified in FCC 15.205. In order to uniform our measurements, all EIRP limits (dBm/MHz) converted into E-Field Limits [dB(uV/m)/MHz] as follows:

$$P = (Ed)^2/30G$$
$$EIRP = PG = (Ed)^2/30$$
$$E = (30 * EIRP)^{0.5}/d$$

Where:

- P: Conducted power at the antenna in Watts
G: Transmitter's isotropic gain in numeric
EIRP: Equivalent isotropic radiated power in Watts
E: Electric Field in uV/m
D: Distance in meters (3 meters)

$$10^6 * E_{V/m} / 10^6 = [30 * EIRP_w * 10^3 / 10^3]^{0.5} / d$$
$$20 * \log[10^6 * E_{V/m} / 10^6] = 20 * \log\{[30 * EIRP_w * 10^3 / 10^3]^{0.5} / d\}$$
$$20 * \log[E_{uV/m}] - 20 * \log[10^6] = 10 * \log[EIRP_{mW}] + 10 * \log[30] + 10 * \log[10^{-3}] - 20 * \log(d)$$
$$E_{dBuV/m} = EIRP_{dBm} + 14.77 - 30 - 9.54 + 120$$

$$E_{dBuV/m} = EIRP_{dBm} + 95.25 \text{ dB}$$

The FCC Equivalent E-Field Limits are:

-17 dB/MHz $\Leftarrow \Rightarrow$ 78.24 dB(uV/m)/MHz
-27 dBm/MHz $\Leftarrow \Rightarrow$ 68.24 dB(uV/m)/MHz

6.2.6.1. Band-edges Emissions (Radiated at 3 Meters)

Since there are no changes in RF output power and signal characteristics. The band-edge radiated emissions are not necessarily to be repeated.

6.2.6.2. Undesired Emissions

Remarks:

- 1) Radiated emissions pre-scans show no differences in RF interferences with different modulations. Therefore, the transmitter operates with 64QAM modulation at highest data rate of 54 Mbps were tested to represent the worst case of radiated emissions, since it output the highest power.
- 2) The emissions were scanned from 10 MHz to 40 GHz and all emissions less 20 dB below the limits were recorded.

6.2.6.2.1. Model No.: ALTITUDE 350-2 DETACH 15939 with External Antenna

6.2.6.2.1.1. For 5.15-5.25 GHz Band

▪ **Transmitter Settings: Channel Frequency: 5180 MHz, Power Setting: 20 dBm**

Frequency (MHz)	RF Peak Level (dBµV/m)	RF AVG Level (dBµV/m)	Antenna Plane (H/V)	Limit 15.209 (dBµV/m)	Limit 15.407 (dBµV/m)	Margin (dB)	Pass/Fail
10360	57.9	44.2	H	54.0	68.2	-24.0	Pass
10360	60.7	47.3	V	54.0	68.2	-20.9	Pass

*Frequency in restricted frequency band.

▪ **Transmitter Settings: Channel Frequency: 5220 MHz, Power Setting: 20 dBm**

Frequency (MHz)	RF Peak Level (dBµV/m)	RF AVG Level (dBµV/m)	Antenna Plane (H/V)	Limit 15.209 (dBµV/m)	Limit 15.407 (dBµV/m)	Margin (dB)	Pass/Fail
10440	58.3	45.3	H	54.0	68.2	-22.9	Pass
10440	60.4	48.0	V	54.0	68.2	-20.2	Pass

*Frequency in restricted frequency band.

▪ **Transmitter Settings: Channel Frequency: 5240 MHz, Power Setting: 20 dBm**

Frequency (MHz)	RF Peak Level (dBµV/m)	RF AVG Level (dBµV/m)	Antenna Plane (H/V)	Limit 15.209 (dBµV/m)	Limit 15.407 (dBµV/m)	Margin (dB)	Pass/Fail
10480	58.2	44.6	H	54.0	68.2	-23.6	Pass
10480	59.2	46.8	V	54.0	68.2	-21.4	Pass

*Frequency in restricted frequency band.

6.2.6.2.1.2. For 5.25-5.35 GHz Band

▪ **Transmitter Settings: Channel Frequency: 5260 MHz, Power Setting: 20 dBm**

Frequency (MHz)	RF Peak Level (dBμV/m)	RF AVG Level (dBμV/m)	Antenna Plane (H/V)	Limit 15.209 (dBμV/m)	Limit 15.407 (dBμV/m)	Margin (dB)	Pass/Fail
10520	58.9	45.8	H	54.0	68.2	-22.4	Pass
10520	60.5	47.6	V	54.0	68.2	-20.6	Pass

*Frequency in restricted frequency band.

▪ **Transmitter Settings: Channel Frequency: 5300 MHz, Power Setting: 20 dBm**

Frequency (MHz)	RF Peak Level (dBμV/m)	RF AVG Level (dBμV/m)	Antenna Plane (H/V)	Limit 15.209 (dBμV/m)	Limit 15.407 (dBμV/m)	Margin (dB)	Pass/Fail
*10600	58.2	45.3	H	54.0	68.2	-8.7	Pass
*10600	58.1	45.6	V	54.0	68.2	-8.4	Pass

*Frequency in restricted frequency band.

▪ **Transmitter Settings: Channel Frequency: 5320 MHz, Power Setting: 20 dBm**

Frequency (MHz)	RF Peak Level (dBμV/m)	RF AVG Level (dBμV/m)	Antenna Plane (H/V)	Limit 15.209 (dBμV/m)	Limit 15.407 (dBμV/m)	Margin (dB)	Pass/Fail
*10640	60.3	46.3	H	54.0	68.2	-7.7	Pass
*10640	56.5	43.6	V	54.0	68.2	-10.4	Pass

*Frequency in restricted frequency band.

6.2.6.2.2. Model No.: ALTITUDE 350-2 INTEG 15938 with Internal Antenna

6.2.6.2.2.1. For 5.15-5.25 GHz Band

▪ **Transmitter Settings: Channel Frequency: 5180 MHz, Power Setting: 17 dBm**

Frequency (MHz)	RF Peak Level (dBµV/m)	RF AVG Level (dBµV/m)	Antenna Plane (H/V)	Limit 15.209 (dBµV/m)	Limit 15.407 (dBµV/m)	Margin (dB)	Pass/Fail
10360	55.8	42.1	H	54.0	68.2	-26.1	Pass
10360	56.3	43.6	V	54.0	68.2	-24.6	Pass

The radiated emissions from the transmitter were scanned from 30 MHz to 40 GHz, and all emission levels less than 30 dB below the FCC Limits 15.209 or 15.407 were recorded.

▪ **Transmitter Settings: Channel Frequency: 5220 MHz, Power Setting: 17 dBm**

Frequency (MHz)	RF Peak Level (dBµV/m)	RF AVG Level (dBµV/m)	Antenna Plane (H/V)	Limit 15.209 (dBµV/m)	Limit 15.407 (dBµV/m)	Margin (dB)	Pass/Fail
10440	55.2	42.1	H	54.0	68.2	-26.1	Pass
10440	56.9	43.5	V	54.0	68.2	-24.7	Pass

The radiated emissions from the transmitter were scanned from 30 MHz to 40 GHz, and all emission levels less than 30 dB below the FCC Limits 15.209 or 15.407 were recorded.

▪ **Transmitter Settings: Channel Frequency: 5240 MHz, Power Setting: 17 dBm**

Frequency (MHz)	RF Peak Level (dBµV/m)	RF AVG Level (dBµV/m)	Antenna Plane (H/V)	Limit 15.209 (dBµV/m)	Limit 15.407 (dBµV/m)	Margin (dB)	Pass/Fail
10480	55.1	41.9	H	54.0	68.2	-26.3	Pass
10480	56.7	43.1	V	54.0	68.2	-25.1	Pass

The radiated emissions from the transmitter were scanned from 30 MHz to 40 GHz, and all emission levels less than 30 dB below the FCC Limits 15.209 or 15.407 were recorded.

6.2.6.2.2.2. For 5.25-5.35 GHz Band

▪ **Transmitter Settings: Channel Frequency: 5260 MHz, Power Setting: 18 dBm**

Frequency (MHz)	RF Peak Level (dBµV/m)	RF AVG Level (dBµV/m)	Antenna Plane (H/V)	Limit 15.209 (dBµV/m)	Limit 15.407 (dBµV/m)	Margin (dB)	Pass/Fail
10520	55.1	41.6	H	54.0	68.2	-26.6	Pass
10520	57.8	43.8	V	54.0	68.2	-24.4	Pass

The radiated emissions from the transmitter were scanned from 30 MHz to 40 GHz, and all emission levels less than 30 dB below the FCC Limits 15.209 or 15.407 were recorded.

▪ **Transmitter Settings: Channel Frequency: 5300 MHz, Power Setting: 18 dBm**

Frequency (MHz)	RF Peak Level (dBµV/m)	RF AVG Level (dBµV/m)	Antenna Plane (H/V)	Limit 15.209 (dBµV/m)	Limit 15.407 (dBµV/m)	Margin (dB)	Pass/Fail
*10600	55.0	41.1	H	54.0	68.2	-12.9	Pass
*10600	56.7	43.1	V	54.0	68.2	-10.9	Pass

The radiated emissions from the transmitter were scanned from 30 MHz to 40 GHz, and all emission levels less than 30 dB below the FCC Limits 15.209 or 15.407 were recorded.

*Frequency in restricted frequency band.

▪ **Transmitter Settings: Channel Frequency: 5320 MHz, Power Setting: 18 dBm**

Frequency (MHz)	RF Peak Level (dBµV/m)	RF AVG Level (dBµV/m)	Antenna Plane (H/V)	Limit 15.209 (dBµV/m)	Limit 15.407 (dBµV/m)	Margin (dB)	Pass/Fail
*10640	54.8	40.9	H	54.0	68.2	-13.1	Pass
*10640	56.1	42.9	V	54.0	68.2	-11.1	Pass

The radiated emissions from the transmitter were scanned from 30 MHz to 40 GHz, and all emission levels less than 30 dB below the FCC Limits 15.209 or 15.407 were recorded.

*Frequency in restricted frequency band.

EXHIBIT 7. MEASUREMENT UNCERTAINTY

The measurement uncertainties stated were calculated in accordance with the requirements of NIST Technical Note 1297 and NIS 81 (1994)

7.1. RADIATED EMISSION MEASUREMENT UNCERTAINTY

CONTRIBUTION (Radiated Emissions)	PROBABILITY DISTRIBUTION	UNCERTAINTY (+ dB)	
		3 m	10 m
Antenna Factor Calibration	Normal (k=2)	± 1.0	± 1.0
Cable Loss Calibration	Normal (k=2)	± 0.3	± 0.5
EMI Receiver specification	Rectangular	± 1.5	± 1.5
Antenna Directivity	Rectangular	+0.5	+0.5
Antenna factor variation with height	Rectangular	± 2.0	± 0.5
Antenna phase center variation	Rectangular	0.0	± 0.2
Antenna factor frequency interpolation	Rectangular	± 0.25	± 0.25
Measurement distance variation	Rectangular	± 0.6	± 0.4
Site imperfections	Rectangular	± 2.0	± 2.0
Mismatch: Receiver VRC $\Gamma_1 = 0.2$ Antenna VRC $\Gamma_R = 0.67(\text{Bi}) 0.3 (\text{Lp})$ Uncertainty limits $20\text{Log}(1 \pm \Gamma_1 \Gamma_R)$	U-Shaped	+1.1 -1.25	± 0.5
System repeatability	Std. Deviation	± 0.5	± 0.5
Repeatability of EUT		-	-
Combined standard uncertainty	Normal	+2.19 / -2.21	+1.74 / -1.72
Expanded uncertainty U	Normal (k=2)	+4.38 / -4.42	+3.48 / -3.44

Calculation for maximum uncertainty when 3m biconical antenna including a factor of k = 2 is used:

$$U = 2u_c(y) = 2x(+2.19) = +4.38 \text{ dB} \quad \text{And} \quad U = 2u_c(y) = 2x(-2.21) = -4.42 \text{ dB}$$

EXHIBIT 8. MEASUREMENT METHODS

8.1. GENERAL TEST CONDITIONS

The following test conditions shall be applied throughout the tests covered in this report.

8.1.1. Normal temperature and humidity

- Normal temperature: +15°C to +35°C
- Relative Humidity: +20% to 75%

The actual values during tests shall be recorded in the test report.

8.1.2. Normal power source

8.1.2.1. Mains Voltage

The nominal test voltage of the equipment to be connected to mains shall be the nominal mains voltage which is the declared voltage or any of the declared voltages for which the equipment was designed.

The frequency of test power source corresponding to the AC mains shall be between 59 Hz and 61 Hz.

8.1.2.2. Battery Power Source

For operation from battery power sources, the nominal test voltage shall be as declared by the equipment manufacturer. This shall be recorded in the test report.

8.1.3. Operating Condition of Equipment under Test

- All tests were carried out while the equipment operated at the following frequencies:
 - The lowest operating frequency,
 - The middle operating frequency and
 - The highest operating frequency
- Modulation were applied using the Test Data sequence
- The transmitter was operated at the highest output power, or in the case the equipment able to operate at more than one power level, at the lowest and highest output powers

8.2. SPURIOUS EMISSIONS (RADIATED)

For both conducted and radiated measurements, the spurious emissions were scanned from the lowest frequency generated by the EUT or 10 MHz whichever is lower to 10th harmonic of the highest frequency generated by the EUT.

- The radiated emission measurements were performed at the UltraTech's 3 Meter Open Field Test Site (OFTS) situated in the Town of Oakville, province of Ontario. The Attenuation Characteristics of OFTS have been filed to FCC, Industry Canada, ACA, NVLap and ITI.
- Radiated emissions measurements were made using the following test instruments:
 1. Calibrated EMCO BiconiLog antenna in the frequency range from 30 MHz to 2000 MHz.
 2. Calibrated Emco Horn antennas in the frequency range above 1000 MHz (1GHz - 40 GHz).
 3. The test is required for any spurious emission or modulation product that falls in a Restricted Band, as defined in Section 15.205. It must be performed with the highest gain of each type of antenna proposed for use with the EUT. Use the following spectrum analyzer settings:
 - RBW = 100 kHz for $f < 1\text{GHz}$ and $\text{RBW} = 1\text{ MHz}$ for $f \geq 1\text{ GHz}$
 - VBW = RBW
 - Sweep = auto
 - Detector function = peak
 - Trace = max hold
 - Follows the guidelines in ANSI C63.4-1992 with respect to maximizing the emission by rotating the EUT, measuring the emission while the EUT is situated in three orthogonal planes (if appropriate), adjusting the measurement antenna height and polarization, etc.. A pre-amp and highpass filter are required for this test, in order to provide the measuring system with sufficient sensitivity.
 - Allow the trace to stabilize.
 - The peak reading of the emission, after being corrected by the antenna correction factor, cable loss, pre-amp gain, etc.... is the peak field strength which comply with the limit specified in Section 15.35(b)

Calculation of Field Strength:

The field strength is calculated by adding the calibrated antenna factor and cable factor, and subtracting the Amplifier gain (if any) from the measured reading. The basic equation with a sample calculation is as follows:

$$\text{FS} = \text{RA} + \text{AF} + \text{CF} - \text{AG}$$

Where	FS	=	Field Strength
	RA	=	Receiver/Analyzer Reading
	AF	=	Antenna Factor
	CF	=	Cable Attenuation Factor
	AG	=	Amplifier Gain

Example: If a receiver reading of 60.0 dBuV is obtained, the antenna factor of 7.0 dB/m and cable factor of 1.0 dB are added, and the amplifier gain of 30 dB is subtracted. The actual field strength will be:

$$\text{Field Level} = 60 + 7.0 + 1.0 - 30 = 38.0 \text{ dBuV/m.}$$

Field Level = $10^{(38/20)} = 79.43$ uV/m.

- Submit this test data
- Now set the VBW to 10Hz, while maintaining all of the other instrument settings. This peak level, once corrected, must comply with the limit specified in Section 15.209. If the dwell time of the each channel is less than 100ms, then the reading obtained may be further adjusted by a “duty cycle correction factor”, derived from $10\log(\text{dwell time}/100\text{mS})$ in an effort to demonstrate compliance with the 15.209.
- Submit test data

Maximizing The Radiated Emissions:

- The frequencies of emissions was first detected. Then the amplitude of the emissions was measured at the specified measurement distance using required antenna height, polarization, and detector characteristics.
- During this process, cables and peripheral devices were manipulated within the range of likely configuration.
- For each mode of operation required to be tested, the frequency spectrum was monitored. Variations in antenna heights (from 1 meter to 4 meters above the ground plane), antenna polarization (horizontal plane and vertical plane), cable placement and peripheral placement were explored to produce the highest amplitude signal relative to the limit.

The maximum radiated emission for a given mode of operation was found by using the following step-by-step procedure:

- Step1: Monitor the frequency range of interest at a fixed antenna height and EUT azimuth.
- Step2: Manipulate the system cables to produce highest amplitude signal relative to the limit. Note the amplitude and frequency of the suspect signal.
- Step3: Rotate the EUT 360 degrees to maximize the suspected highest amplitude signal. If the signal or another at a different frequency is observed to exceed the previously noted highest amplitude signal by 1 dB or more, go back to the azimuth and repeat Step 2. Otherwise, orient the EUT azimuth to repeat the highest amplitude observation and proceed.
- Step4: Move the antenna over its full allowable range of travel (1 to 4 meters) to maximize the suspected highest amplitude signal. If the signal or another at a different frequency is observed to exceed the previously noted highest amplitude signal by 1 dB or more, return to Step 2 with the highest amplitude observation and proceed.
- Step5: Change the polarization of the Antenna and repeat Step 2 through 4. Compare the resulting suspected highest amplitude signal with that found for the other polarization. Select and note the higher of the two signals. This signal is termed the highest observed signal with respect to the limit for this EUT operational mode.
- Step6: The effects of various modes of operation is examined. This is done by varying the equipment modes as steps 2 through 5 are being performed.
- Step7: After completing steps 1 through 6, record the final highest emission level, frequency, antenna polarization and detector mode of the measuring instrument.