



# RADIO TEST REPORT

**FCC ID** : RIWZAT6000  
**Equipment** : ATSC 3.0 STB  
**Brand Name** : ZINWELL  
**Model Name** : ZAT-6000  
**Applicant** : ZINWELL CORPORATION  
No. 2 Wen-Hua Road, Hsinchu Industrial Park, Hsinchu, Taiwan  
**Manufacturer** : ZINWELL CORPORATION  
No. 2 Wen-Hua Road, Hsinchu Industrial Park, Hsinchu, Taiwan  
**Standard** : 47 CFR FCC Part 15.247

The product was received on Aug. 23, 2023, and testing was started from Aug. 24, 2023 and completed on Sep. 04, 2023. We, Sporton International Inc. Hsinchu Laboratory, would like to declare that the tested sample has been evaluated in accordance with the procedures given in ANSI C63.10-2013 and shown compliance with the applicable technical standards.

The test results in this report apply exclusively to the tested model / sample. Without written approval of Sporton International Inc. Hsinchu Laboratory, the test report shall not be reproduced except in full.

Approved by: Sam Chen

**Sporton International Inc. Hsinchu Laboratory**

No.8, Ln. 724, Bo'ai St., Zhubei City, Hsinchu County 302010, Taiwan (R.O.C.)



## Table of Contents

**History of this test report.....3**

**Summary of Test Result.....4**

**1 General Description .....5**

1.1 Information.....5

1.2 Applicable Standards .....7

1.3 Testing Location Information .....7

1.4 Measurement Uncertainty .....7

**2 Test Configuration of EUT .....8**

2.1 Test Channel Mode .....8

2.2 The Worst Case Measurement Configuration .....9

2.3 EUT Operation during Test .....10

2.4 Accessories .....10

2.5 Support Equipment.....10

2.6 Test Setup Diagram .....12

**3 Transmitter Test Result .....15**

3.1 AC Power-line Conducted Emissions .....15

3.2 DTS Bandwidth.....17

3.3 Maximum Conducted Output Power .....18

3.4 Power Spectral Density .....21

3.5 Emissions in Non-restricted Frequency Bands .....23

3.6 Emissions in Restricted Frequency Bands.....24

**4 Test Equipment and Calibration Data .....28**

**Appendix A. Test Results of AC Power-line Conducted Emissions**

**Appendix B. Test Results of DTS Bandwidth**

**Appendix C. Test Results of Maximum Conducted Output Power**

**Appendix D. Test Results of Power Spectral Density**

**Appendix E. Test Results of Emissions in Non-restricted Frequency Bands**

**Appendix F. Test Results of Emissions in Restricted Frequency Bands**

**Appendix G. Test Photos**

**Photographs of EUT v01**





## Summary of Test Result

| Report Clause | Ref Std. Clause | Test Items                                  | Result (PASS/FAIL) | Remark |
|---------------|-----------------|---|--------------------|--------|
| 1.1.2         | 15.203          | Antenna Requirement                         | PASS               | -      |
| 3.1           | 15.207          | AC Power-line Conducted Emissions           | PASS               | -      |
| 3.2           | 15.247(a)       | DTS Bandwidth                               | PASS               | -      |
| 3.3           | 15.247(b)       | Maximum Conducted Output Power              | PASS               | -      |
| 3.4           | 15.247(e)       | Power Spectral Density                      | PASS               | -      |
| 3.5           | 15.247(d)       | Emissions in Non-restricted Frequency Bands | PASS               | -      |
| 3.6           | 15.247(d)       | Emissions in Restricted Frequency Bands     | PASS               | -      |

**Conformity Assessment Condition:**

1. The test results (PASS/FAIL) with all measurement uncertainty excluded are presented against the regulation limits or in accordance with the requirements stipulated by the applicant/manufacture who shall bear all the risks of non-compliance that may potentially occur if measurement uncertainty is taken into account.
2. The measurement uncertainty please refer to each test result in the chapter "Measurement Uncertainty".

**Disclaimer:**

The product specifications of the EUT presented in the test report that may affect the test assessments are declared by the manufacturer who shall take full responsibility for the authenticity.

**Reviewed by: Sam Chen****Report Producer: Viola Huang**



# 1 General Description

## 1.1 Information

### 1.1.1 RF General Information

| Frequency Range (MHz) | IEEE Std. 802.11 | Ch. Frequency (MHz) | Channel Number |
|-----------------------|------------------|---------------------|----------------|
| 2400-2483.5           | b, g, n (HT20)   | 2412-2462           | 1-11 [11]      |
| 2400-2483.5           | n (HT40)         | 2422-2452           | 3-9 [7]        |

| Band          | Mode         | BWch (MHz) | Nant |
|---------------|--------------|------------|------|
| 2.4-2.4835GHz | 802.11b      | 20         | 1TX  |
| 2.4-2.4835GHz | 802.11g      | 20         | 1TX  |
| 2.4-2.4835GHz | 802.11n HT20 | 20         | 1TX  |
| 2.4-2.4835GHz | 802.11n HT40 | 40         | 1TX  |

**Note:**

- ◆ 11b mode uses a combination of DSSS-DBPSK, DQPSK, CCK modulation.
- ◆ 11g, HT20 and HT40 use a combination of OFDM-BPSK, QPSK, 16QAM, 64QAM modulation.
- ◆ BWch is the nominal channel bandwidth.



**1.1.2 Antenna Information**

| Ant. | Port | Brand | Model Name | Antenna Type | Connector | Gain (dBi) |             |             |
|------|------|-------|------------|--------------|-----------|------------|-------------|-------------|
|      |      |       |            |              |           | 2.4GHz     | 5GHz UNII 1 | 5GHz UNII 3 |
| 1    | 1    | INPAQ | ZAT-6000   | PCB Antenna  | I-PEX     | 2.42       | 3.13        | 4.41        |

Note: The above information was declared by manufacturer.

<For 2.4GHz Band>

**For IEEE 802.11b/g/n mode (1TX/1RX)**

Only Port 1 can be used as transmitting/receiving antenna.

<For 5GHz Band UNII 1, UNII 3>

**For IEEE 802.11a/n/ac mode (1TX/1RX)**

Only Port 1 can be used as transmitting/receiving antenna.

**1.1.3 Mode Test Duty Cycle**

| Mode         | DC    | DCF(dB) | T(s)           | VBW(Hz) ≥ 1/T  |
|--------------|-------|---------|----------------|----------------|
| 802.11b      | 0.99  | 0.04    | n/a (DC>=0.98) | n/a (DC>=0.98) |
| 802.11g      | 0.959 | 0.18    | 2.066m         | 1k             |
| 802.11n HT20 | 0.948 | 0.23    | 1.921m         | 1k             |
| 802.11n HT40 | 0.881 | 0.55    | 945u           | 3k             |

Note:

- ♦ DC is Duty Cycle.
- ♦ DCF is Duty Cycle Factor.

**1.1.4 EUT Operational Condition**

|                              |                                     |                     |                                     |                     |
|------------------------------|-------------------------------------|---------------------|-------------------------------------|---------------------|
| <b>EUT Power Type</b>        | From Power Adapter                  |                     |                                     |                     |
| <b>Beamforming Function</b>  | <input type="checkbox"/>            | With beamforming    | <input checked="" type="checkbox"/> | Without beamforming |
| <b>Function</b>              | <input checked="" type="checkbox"/> | Point-to-multipoint | <input type="checkbox"/>            | Point-to-point      |
| <b>Test Software Version</b> | DOS [ver 10.0.10586]                |                     |                                     |                     |

Note: The above information was declared by manufacturer.



### 1.2 Applicable Standards

According to the specifications of the manufacturer, the EUT must comply with the requirements of the following standards:

- ◆ 47 CFR FCC Part 15.247
- ◆ ANSI C63.10-2013

The following reference test guidance is not within the scope of accreditation of TAF.

- ◆ FCC KDB 558074 D01 v05r02
- ◆ FCC KDB 662911 D01 v02r01
- ◆ FCC KDB 414788 D01 v01r01

### 1.3 Testing Location Information

| Testing Location Information                                    |  |
|---|--|
| Test Lab. : Sporton International Inc. Hsinchu Laboratory       |  |
| Hsinchu   | ADD: No.8, Ln. 724, Bo'ai St., Zhubei City, Hsinchu County 302010, Taiwan (R.O.C.) |
| (TAF: 3787)   | TEL: 886-3-656-9065      FAX: 886-3-656-9085                                       |
| Test site Designation No. TW3787 with FCC.                      |  |
| Conformity Assessment Body Identifier (CABID) TW3787 with ISED. |  |

| Test Condition      | Test Site No. | Test Engineer | Test Environment (°C / %) | Test Date                   |
|---------------------|---------------|---------------|---------------------------|-----------------------------|
| RF Conducted        | TH02-CB       | KJ Chang      | 22.5~24.7 / 62~68         | Sep. 04, 2023               |
| Radiated Below 1GHz | 03CH03-CB     | Wendy Hsu     | 22.4~23.5 / 55~58         | Aug. 31, 2023               |
| Radiated Above 1GHz | 03CH03-CB     | Wendy Hsu     | 22.4~23.5 / 55~58         | Aug. 24, 2023~Sep. 02, 2023 |
| AC Conduction       | CO01-CB       | Summer Li     | 22~23 / 50~51             | Sep. 04, 2023               |

### 1.4 Measurement Uncertainty

ISO/IEC 17025 requires that an estimate of the measurement uncertainties associated with the emissions test results be included in the report. The measurement uncertainties given below are based on a 95% confidence level (based on a coverage factor (k=2))

| Test Items                           | Uncertainty | Remark                   |
|--------------------------------------|-------------|--------------------------|
| Conducted Emission (150kHz ~ 30MHz)  | 3.4 dB      | Confidence levels of 95% |
| Radiated Emission (9kHz ~ 30MHz)     | 3.7 dB      | Confidence levels of 95% |
| Radiated Emission (30MHz ~ 1,000MHz) | 5.1 dB      | Confidence levels of 95% |
| Radiated Emission (1GHz ~ 18GHz)     | 4.1 dB      | Confidence levels of 95% |
| Radiated Emission (18GHz ~ 40GHz)    | 4.2 dB      | Confidence levels of 95% |
| Conducted Emission                   | 3.1 dB      | Confidence levels of 95% |
| Output Power Measurement             | 0.8 dB      | Confidence levels of 95% |
| Power Density Measurement            | 3.1 dB      | Confidence levels of 95% |
| Bandwidth Measurement                | 2.2%        | Confidence levels of 95% |



## 2 Test Configuration of EUT

### 2.1 Test Channel Mode

| Mode                         | Power Setting |
|------------------------------|---------------|
| 802.11b_Nss1,(1Mbps)_1TX     | -             |
| 2412MHz                      | 57            |
| 2437MHz                      | 55            |
| 2462MHz                      | 52            |
| 802.11g_Nss1,(6Mbps)_1TX     | -             |
| 2412MHz                      | 57            |
| 2417MHz                      | 63            |
| 2437MHz                      | 63            |
| 2457MHz                      | 63            |
| 2462MHz                      | 56            |
| 802.11n HT20_Nss1,(MCS0)_1TX | -             |
| 2412MHz                      | 55            |
| 2417MHz                      | 63            |
| 2437MHz                      | 63            |
| 2457MHz                      | 63            |
| 2462MHz                      | 55            |
| 802.11n HT40_Nss1,(MCS0)_1TX | -             |
| 2422MHz                      | 53            |
| 2427MHz                      | 53            |
| 2437MHz                      | 56            |
| 2447MHz                      | 52            |
| 2452MHz                      | 51            |





## 2.2 The Worst Case Measurement Configuration

| The Worst Case Mode for Following Conformance Tests   |   |
|---|---|
| <b>Tests Item</b>   | AC power-line conducted emissions   |
| <b>Condition</b>  | AC power-line conducted measurement for line and neutral<br>Test Voltage: 120Vac / 60Hz |
| <b>Operating Mode</b>   | Normal Link   |
| 1   | EUT with WLAN 2.4GHz + Coaxial port-Video IN + USB port-load + Adapter                  |
| 2   | EUT with WLAN 5GHz + Coaxial port-Video IN + USB port-load + Adapter                    |
| Mode 1 has been evaluated to be the worst case among Mode 1~2, thus measurement for Mode 3 will follow this same test mode. |   |
| 3   | EUT with WLAN 2.4GHz + Coaxial port-load + USB port-Video IN + Adapter                  |
| For operating mode 3 is the worst case and it was record in this test report.   |   |

| The Worst Case Mode for Following Conformance Tests |  |
|---|--|
| <b>Tests Item</b>                                   | DTS Bandwidth<br>Maximum Conducted Output Power<br>Power Spectral Density<br>Emissions in Non-restricted Frequency Bands |
| <b>Test Condition</b>                               | Conducted measurement at transmit chains   |

| The Worst Case Mode for Following Conformance Tests   |   |
|---|---|
| <b>Tests Item</b>   | Emissions in Restricted Frequency Bands   |
| <b>Test Condition</b>   | Radiated measurement<br>If EUT consist of multiple antenna assembly (multiple antenna are used in EUT regardless of spatial multiplexing MIMO configuration), the radiated test should be performed with highest antenna gain of each antenna type. |
| <b>Operating Mode &lt; 1GHz</b>   | Normal Link<br>After evaluating, the worst case was found at Z axis, so it was selected to perform test and its test result was written in the report.  |
| 1   | EUT in Z axis with WLAN 2.4GHz + Coaxial port-Video IN + USB port-load + Adapter  |
| 2   | EUT in Z axis with WLAN 5GHz + Coaxial port-Video IN + USB port-load + Adapter  |
| Mode 2 has been evaluated to be the worst case among Mode 1~2, thus measurement for Mode 3 will follow this same test mode. |   |
| 3   | EUT in Z axis with WLAN 5GHz + Coaxial port-load + USB port-Video IN + Adapter  |
| For operating mode 3 is the worst case and it was record in this test report.   |   |
| <b>Operating Mode &gt; 1GHz</b>   | CTX<br>After evaluating, the worst case was found at Z axis, so it was selected to perform test and its test result was written in the report.  |
| 1   | EUT in Z axis   |



## 2.3 EUT Operation during Test

For CTX Mode:

The EUT was programmed to be in continuously transmitting mode.

For Normal Link Mode:

During the test, the EUT operation to normal function.

## 2.4 Accessories

| Accessories                    |            |             |   |
|--------------------------------|------------|-------------|---|
| Equipment Name                 | Brand Name | Model Name  | Rating  |
| Adapter                        | APD        | WB-18Q12FU1 | INPUT: 100-240V~,50-60Hz,0.6A Max.<br>OUTPUT: 12V, 1.5A |
| Others                         |            |             |   |
| Remote controller*1            |            |             |   |
| HDMI cable*1: Shielding, 3m    |            |             |   |
| Coaxial cable*1: Shielding, 3m |            |             |   |
| Window antenna*1               |            |             |   |

## 2.5 Support Equipment

For AC Conduction:

| Support Equipment |               |            |              |              |
|-------------------|---------------|------------|--------------|--------------|
| No.               | Equipment     | Brand Name | Model Name   | FCC ID       |
| A                 | Flash disk3.0 | Transcend  | JetFlash-700 | N/A          |
| B                 | LCD Monitor   | PHILIPS    | 288E2A/96    | N/A          |
| D                 | AP Router     | ASUS       | RT-AX88U     | MSQ-RTAXHP00 |
| E                 | LAN NB        | DELL       | T3400        | N/A          |

For Radiated (below 1GHz):

| Support Equipment |               |            |              |        |
|-------------------|---------------|------------|--------------|--------|
| No.               | Equipment     | Brand Name | Model Name   | FCC ID |
| A                 | WLAN AP       | NETGEAR    | N600         | N/A    |
| B                 | LAN NB        | DELL       | E4300        | N/A    |
| C                 | LCD TV        | PHILIPS    | 288E2A/96    | N/A    |
| D                 | Flash disk3.0 | Transcend  | JetFlash-700 | N/A    |



**For Radiated (above 1GHz) and RF Conducted:**

| <b>Support Equipment</b> |                  |                   |                   |               |
|--------------------------|------------------|-------------------|-------------------|---------------|
| <b>No.</b>               | <b>Equipment</b> | <b>Brand Name</b> | <b>Model Name</b> | <b>FCC ID</b> |
| A                        | NB               | DELL              | E4300             | N/A           |

## 2.6 Test Setup Diagram

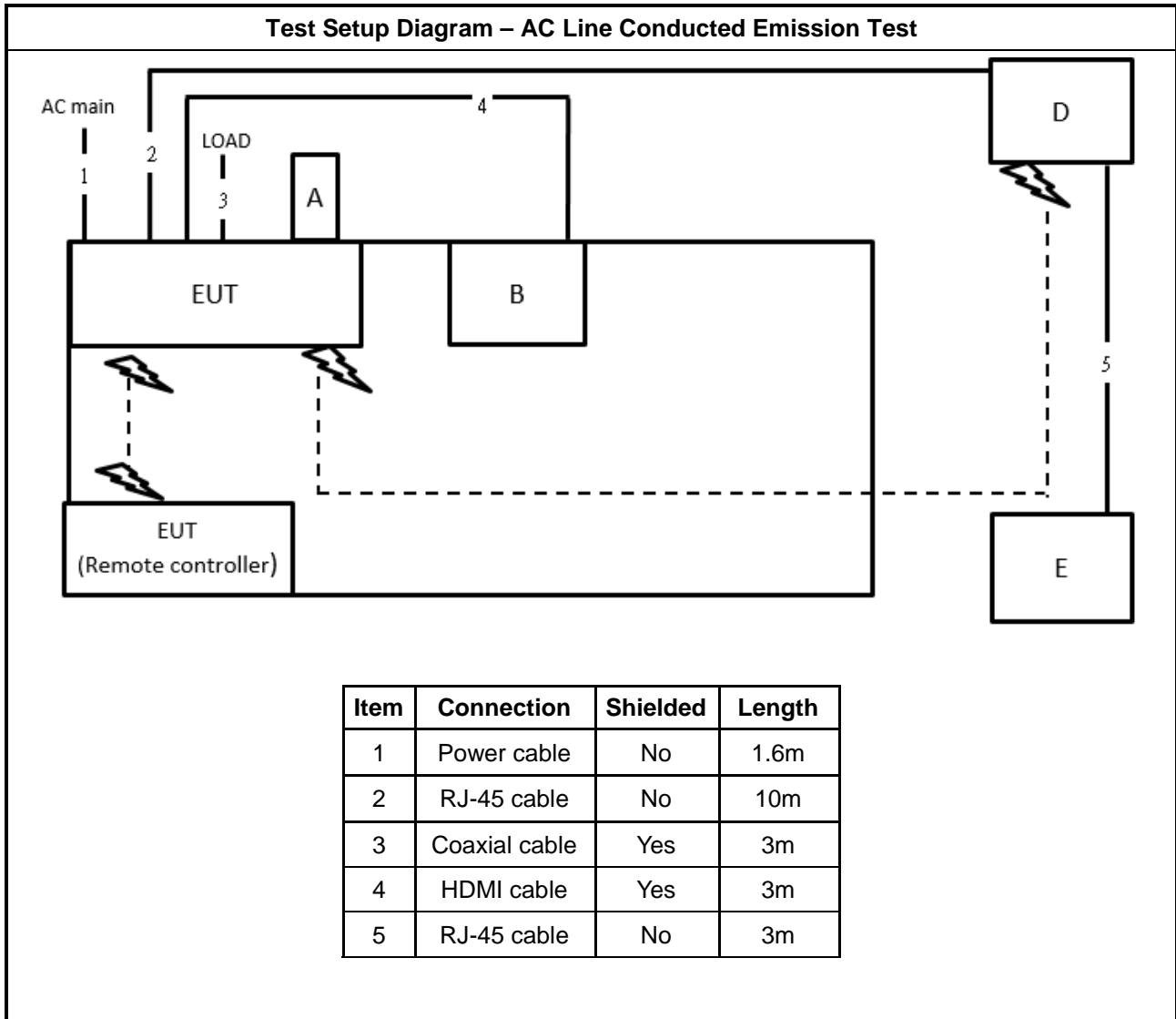

**Test Setup Diagram - Radiated Test < 1GHz**

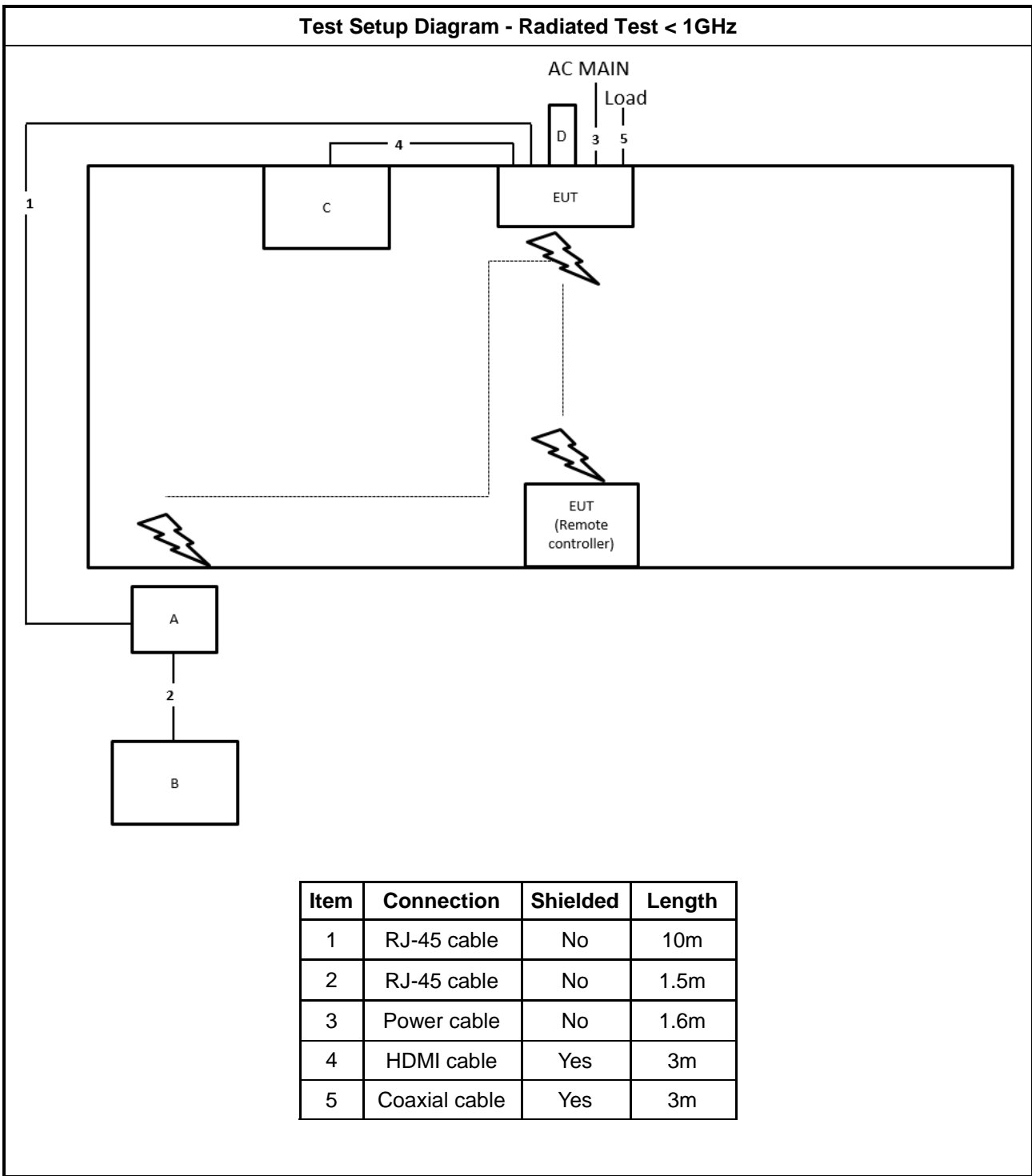

| Item | Connection    | Shielded | Length |
|------|---------------|----------|--------|
| 1    | RJ-45 cable   | No       | 10m    |
| 2    | RJ-45 cable   | No       | 1.5m   |
| 3    | Power cable   | No       | 1.6m   |
| 4    | HDMI cable    | Yes      | 3m     |
| 5    | Coaxial cable | Yes      | 3m     |

**Test Setup Diagram - Radiated Test > 1GHz**

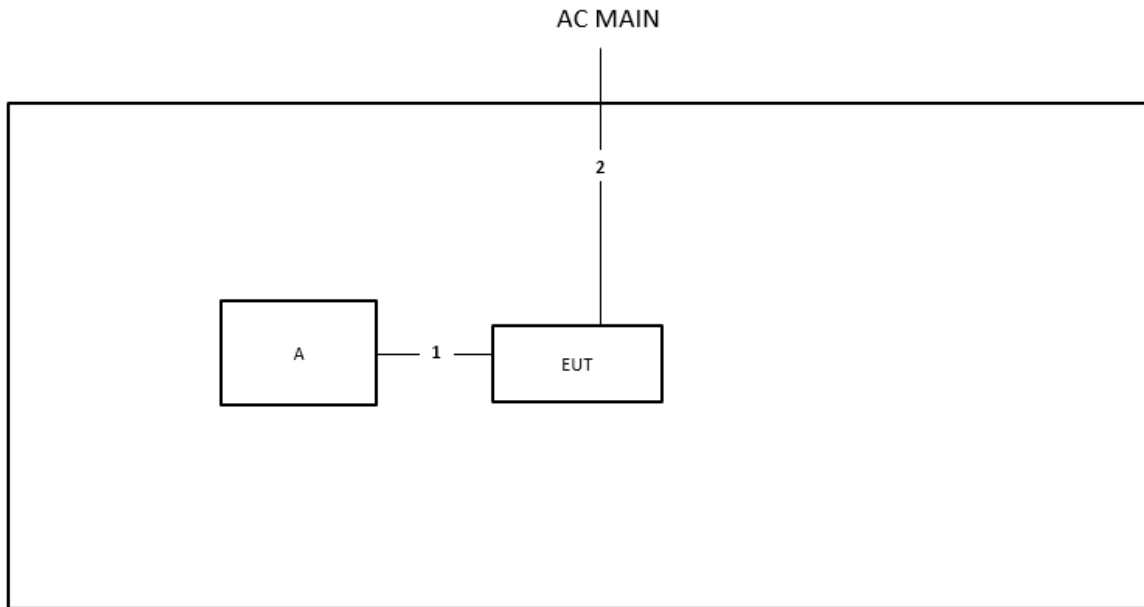

| Item | Connection  | Shielded | Length |
|------|-------------|----------|--------|
| 1    | RJ-45 cable | No       | 1.5m   |
| 2    | Power cable | No       | 1.6m   |



### 3 Transmitter Test Result

#### 3.1 AC Power-line Conducted Emissions

##### 3.1.1 AC Power-line Conducted Emissions Limit

| AC Power-line Conducted Emissions Limit |            |           |
|---|------------|-----------|
| Frequency Emission (MHz)                | Quasi-Peak | Average   |
| 0.15-0.5                                | 66 - 56 *  | 56 - 46 * |
| 0.5-5                                   | 56         | 46        |
| 5-30                                    | 60         | 50        |

Note 1: \* Decreases with the logarithm of the frequency.

##### 3.1.2 Measuring Instruments

Refer a test equipment and calibration data table in this test report.

##### 3.1.3 Test Procedures

| Test Method  |
|--|
| <input checked="" type="checkbox"/> Refer as ANSI C63.10-2013, clause 6.2 for AC power-line conducted emissions. |

### 3.1.4 Test Setup

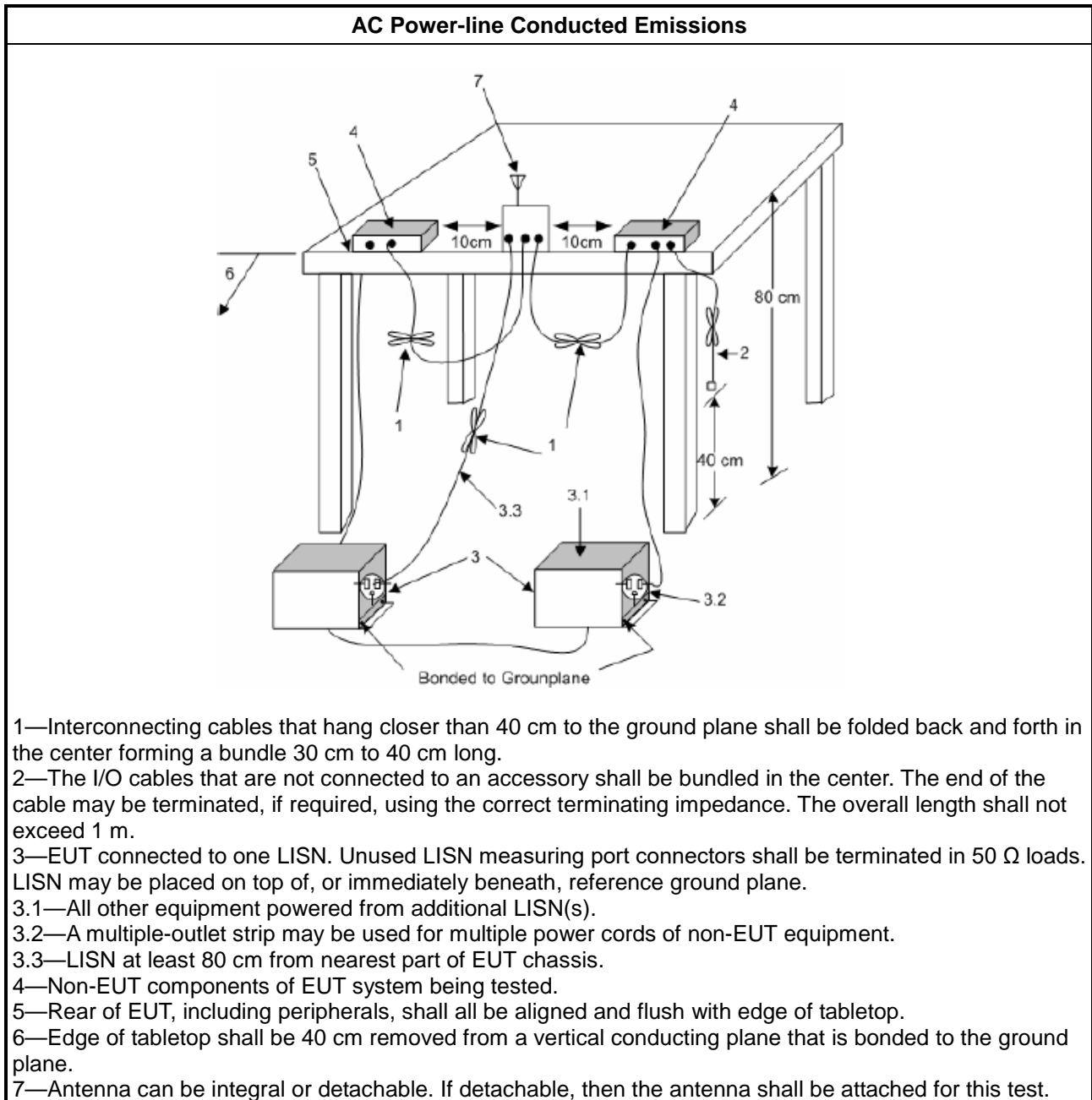

### 3.1.5 Measurement Results Calculation

The measured Level is calculated using:

- a. Corrected Reading: LISN Factor (LISN) + Attenuator (AT/AUX) + Cable Loss (CL) + Read Level (Raw) = Level
- b. Margin = -Limit + Level

### 3.1.6 Test Result of AC Power-line Conducted Emissions

Refer as Appendix A



### 3.2 DTS Bandwidth

#### 3.2.1 6dB Bandwidth Limit

| 6dB Bandwidth Limit   |
|---|
| <b>Systems using digital modulation techniques:</b>   |
| <ul style="list-style-type: none"> <li>▪ 6 dB bandwidth <math>\geq</math> 500 kHz.</li> </ul> |

#### 3.2.2 Measuring Instruments

Refer a test equipment and calibration data table in this test report.

#### 3.2.3 Test Procedures

| Test Method   |
|---|
| <ul style="list-style-type: none"> <li>▪ For the emission bandwidth shall be measured using one of the options below:</li> </ul>        |
| <input checked="" type="checkbox"/> Refer as FCC KDB 558074, clause 8.2 & C63.10 clause 11.8.1 Option 1 for 6 dB bandwidth measurement. |
| <input type="checkbox"/> Refer as FCC KDB 558074, clause 8.2 & C63.10 clause 11.8.2 Option 2 for 6 dB bandwidth measurement.            |
| <input type="checkbox"/> Refer as ANSI C63.10, clause 6.9.1 for occupied bandwidth testing.   |

#### 3.2.4 Test Setup

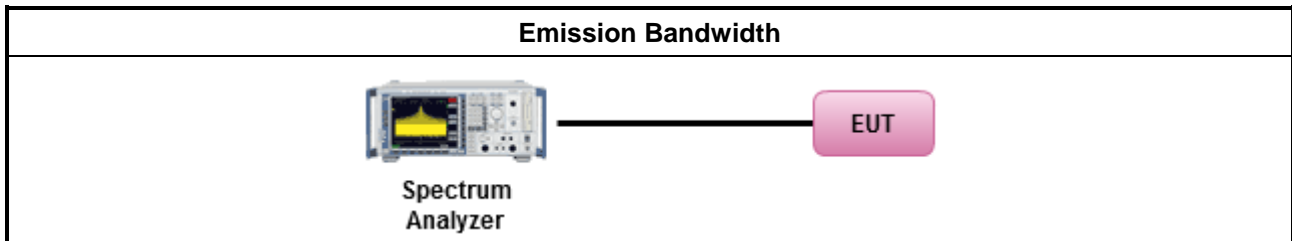

#### 3.2.5 Test Result of Emission Bandwidth

Refer as Appendix B



### 3.3 Maximum Conducted Output Power

#### 3.3.1 Maximum Conducted Output Power Limit

| Maximum Conducted Output Power Limit  |   |
|---|---|
|   | <ul style="list-style-type: none"> <li>▪ If <math>G_{TX} \leq 6</math> dBi, then <math>P_{Out} \leq 30</math> dBm (1 W)</li> </ul>  |
|   | <ul style="list-style-type: none"> <li>▪ Point-to-multipoint systems (P2M): If <math>G_{TX} &gt; 6</math> dBi, then <math>P_{Out} = 30 - (G_{TX} - 6)</math> dBm</li> </ul>     |
|   | <ul style="list-style-type: none"> <li>▪ Point-to-point systems (P2P): If <math>G_{TX} &gt; 6</math> dBi, then <math>P_{Out} = 30 - (G_{TX} - 6)/3</math> dBm</li> </ul>        |
|   | <ul style="list-style-type: none"> <li>▪ Smart antenna system (SAS):</li> </ul>   |
|   | <ul style="list-style-type: none"> <li>- Single beam: If <math>G_{TX} &gt; 6</math> dBi, then <math>P_{Out} = 30 - (G_{TX} - 6)/3</math> dBm</li> </ul>                         |
|   | <ul style="list-style-type: none"> <li>- Overlap beam: If <math>G_{TX} &gt; 6</math> dBi, then <math>P_{Out} = 30 - (G_{TX} - 6)/3</math> dBm</li> </ul>                        |
|   | <ul style="list-style-type: none"> <li>- Aggregate power on all beams: If <math>G_{TX} &gt; 6</math> dBi, then <math>P_{Out} = 30 - (G_{TX} - 6)/3 + 8</math> dB dBm</li> </ul> |
| $P_{Out}$ = maximum peak conducted output power or maximum conducted output power in dBm,<br>$G_{TX}$ = the maximum transmitting antenna directional gain in dBi. |   |

#### 3.3.2 Measuring Instruments

Refer a test equipment and calibration data table in this test report.



**3.3.3 Test Procedures**

| Test Method   |  |
|---|--|
| <ul style="list-style-type: none"> <li>▪ Maximum Peak Conducted Output Power</li> </ul> |  |
|   | <input type="checkbox"/> Refer as FCC KDB 558074, clause 8.3.1.1 & C63.10 clause 11.9.1.1 (RBW ≥ EBW method).  |
|   | <input type="checkbox"/> Refer as FCC KDB 558074, clause 8.3.1.3 & C63.10 clause 11.9.1.3 (peak power meter).  |
| <ul style="list-style-type: none"> <li>▪ Maximum Conducted Output Power</li> </ul>      |  |
|   | [duty cycle ≥ 98% or external video / power trigger]   |
|   | <input type="checkbox"/> Refer as FCC KDB 558074, clause 8.3.2.2 & C63.10 clause 11.9.2.2.2 Method AVGSA-1.  |
|   | <input type="checkbox"/> Refer as FCC KDB 558074, clause 8.3.2.2 & C63.10 clause 11.9.2.2.3 Method AVGSA-1A. (alternative)   |
|   | duty cycle < 98% and average over on/off periods with duty factor  |
|   | <input type="checkbox"/> Refer as FCC KDB 558074, clause 8.3.2.2 & C63.10 clause 11.9.2.2.4 Method AVGSA-2.  |
|   | <input type="checkbox"/> Refer as FCC KDB 558074, clause 8.3.2.2 & C63.10 clause 11.9.2.2.5 Method AVGSA-2A (alternative)  |
|   | <input type="checkbox"/> Refer as FCC KDB 558074, clause 8.3.2.2 & C63.10 clause 11.9.2.2.6 Method AVGSA-3   |
|   | <input type="checkbox"/> Refer as FCC KDB 558074, clause 8.3.2.2 & C63.10 clause 11.9.2.2.7 Method AVGSA-3A (alternative)  |
|   | Measurement using a power meter (PM)   |
|   | <input type="checkbox"/> Refer as FCC KDB 558074, clause 8.3.2.3 & C63.10 clause 11.9.2.3.1 Method AVGPM (using an RF average power meter).  |
|   | <input checked="" type="checkbox"/> Refer as FCC KDB 558074, clause 8.3.2.3 & C63.10 clause 11.9.2.3.2 Method AVGPM-G (using an gate RF average power meter).  |
| <ul style="list-style-type: none"> <li>▪ For conducted measurement.</li> </ul>          |  |
|   | <ul style="list-style-type: none"> <li>▪ If the EUT supports multiple transmit chains using options given below:<br/>Refer as FCC KDB 662911, In-band power measurements. Using the measure-and-sum approach, measured all transmit ports individually. Sum the power (in linear power units e.g., mW) of all ports for each individual sample and save them.</li> </ul> |
|   | <ul style="list-style-type: none"> <li>▪ If multiple transmit chains, EIRP calculation could be following as methods:<br/> <math display="block">P_{total} = P_1 + P_2 + \dots + P_n</math>                     (calculated in linear unit [mW] and transfer to log unit [dBm])<br/> <math display="block">EIRP_{total} = P_{total} + DG</math> </li> </ul>              |

### 3.3.4 Test Setup

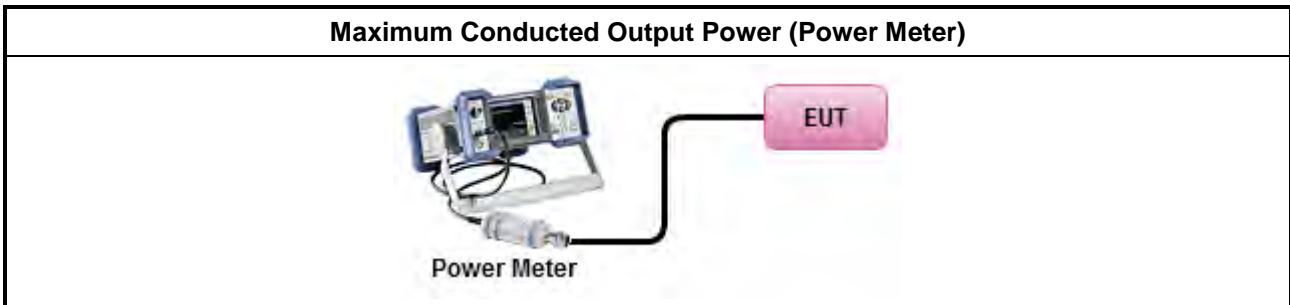

### 3.3.5 Test Result of Maximum Conducted Output Power

Refer as Appendix C



### 3.4 Power Spectral Density

#### 3.4.1 Power Spectral Density Limit

| Power Spectral Density Limit  |
|---|
| <ul style="list-style-type: none"> <li>Power Spectral Density (PSD) <math>\leq</math> 8 dBm/3kHz</li> </ul> |

#### 3.4.2 Measuring Instruments

Refer a test equipment and calibration data table in this test report.

#### 3.4.3 Test Procedures

| Test Method  |   |   |  |
|--|---|---|--|
| <ul style="list-style-type: none"> <li>Peak power spectral density procedures that the same method as used to determine the conducted output power. If maximum peak conducted output power was measured to demonstrate compliance to the output power limit, then the peak PSD procedure below (Method PKPSD) shall be used. If maximum conducted output power was measured to demonstrate compliance to the output power limit, then one of the average PSD procedures shall be used, as applicable based on the following criteria (the peak PSD procedure is also an acceptable option).</li> </ul>   |   |   |  |
| <input checked="" type="checkbox"/> Refer as FCC KDB 558074, clause 8.4 & C63.10 clause 11.10 Method Max. PSD.   |   |   |  |
| <ul style="list-style-type: none"> <li>For conducted measurement.             <ul style="list-style-type: none"> <li>If The EUT supports multiple transmit chains using options given below:                 <table border="1"> <tbody> <tr> <td> <input type="checkbox"/> Option 1: Measure and sum the spectra across the outputs. Refer as FCC KDB 662911, In-band power spectral density (PSD). Sample all transmit ports simultaneously using a spectrum analyzer for each transmit port. Where the trace bin-by-bin of each transmit port summing can be performed. (i.e., in the first spectral bin of output 1 is summed with that in the first spectral bin of output 2 and that from the first spectral bin of output 3, and so on up to the NTX output to obtain the value for the first frequency bin of the summed spectrum.). Add up the amplitude (power) values for the different transmit chains and use this as the new data trace.                 </td> </tr> <tr> <td> <input type="checkbox"/> Option 2: Measure and sum spectral maxima across the outputs. With this technique, spectra are measured at each output of the device at the required resolution bandwidth. The maximum value (peak) of each spectrum is determined. These maximum values are then summed mathematically in linear power units across the outputs. These operations shall be performed separately over frequency spans that have different out-of-band or spurious emission limits,                 </td> </tr> <tr> <td> <input type="checkbox"/> Option 3: Measure and add 10 log(N) dB, where N is the number of transmit chains. Refer as FCC KDB 662911, In-band power spectral density (PSD). Performed at each transmit chains and each transmit chains shall be compared with the limit have been reduced with 10 log(N). Or each transmit chains shall be add 10 log(N) to compared with the limit.                 </td> </tr> </tbody> </table> </li> </ul> </li> </ul> | <input type="checkbox"/> Option 1: Measure and sum the spectra across the outputs. Refer as FCC KDB 662911, In-band power spectral density (PSD). Sample all transmit ports simultaneously using a spectrum analyzer for each transmit port. Where the trace bin-by-bin of each transmit port summing can be performed. (i.e., in the first spectral bin of output 1 is summed with that in the first spectral bin of output 2 and that from the first spectral bin of output 3, and so on up to the NTX output to obtain the value for the first frequency bin of the summed spectrum.). Add up the amplitude (power) values for the different transmit chains and use this as the new data trace. | <input type="checkbox"/> Option 2: Measure and sum spectral maxima across the outputs. With this technique, spectra are measured at each output of the device at the required resolution bandwidth. The maximum value (peak) of each spectrum is determined. These maximum values are then summed mathematically in linear power units across the outputs. These operations shall be performed separately over frequency spans that have different out-of-band or spurious emission limits, | <input type="checkbox"/> Option 3: Measure and add 10 log(N) dB, where N is the number of transmit chains. Refer as FCC KDB 662911, In-band power spectral density (PSD). Performed at each transmit chains and each transmit chains shall be compared with the limit have been reduced with 10 log(N). Or each transmit chains shall be add 10 log(N) to compared with the limit. |
| <input type="checkbox"/> Option 1: Measure and sum the spectra across the outputs. Refer as FCC KDB 662911, In-band power spectral density (PSD). Sample all transmit ports simultaneously using a spectrum analyzer for each transmit port. Where the trace bin-by-bin of each transmit port summing can be performed. (i.e., in the first spectral bin of output 1 is summed with that in the first spectral bin of output 2 and that from the first spectral bin of output 3, and so on up to the NTX output to obtain the value for the first frequency bin of the summed spectrum.). Add up the amplitude (power) values for the different transmit chains and use this as the new data trace.  |   |   |  |
| <input type="checkbox"/> Option 2: Measure and sum spectral maxima across the outputs. With this technique, spectra are measured at each output of the device at the required resolution bandwidth. The maximum value (peak) of each spectrum is determined. These maximum values are then summed mathematically in linear power units across the outputs. These operations shall be performed separately over frequency spans that have different out-of-band or spurious emission limits,  |   |   |  |
| <input type="checkbox"/> Option 3: Measure and add 10 log(N) dB, where N is the number of transmit chains. Refer as FCC KDB 662911, In-band power spectral density (PSD). Performed at each transmit chains and each transmit chains shall be compared with the limit have been reduced with 10 log(N). Or each transmit chains shall be add 10 log(N) to compared with the limit.   |   |   |  |

### 3.4.4 Test Setup

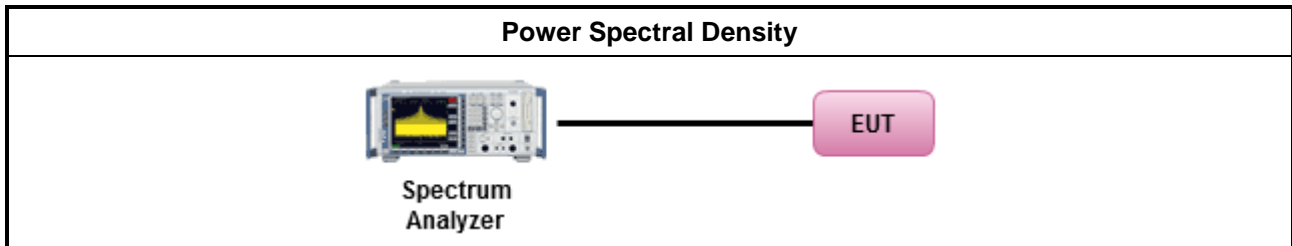

### 3.4.5 Test Result of Power Spectral Density

Refer as Appendix D

### 3.5 Emissions in Non-restricted Frequency Bands

#### 3.5.1 Emissions in Non-restricted Frequency Bands Limit

| Un-restricted Band Emissions Limit |             |
|------------------------------------|-------------|
| RF output power procedure          | Limit (dBc) |
| Peak output power procedure        | 20          |
| Average output power procedure     | 30          |

Note 1: If the peak output power procedure is used to measure the fundamental emission power to demonstrate compliance to requirements, then the peak conducted output power measured within any 100 kHz outside the authorized frequency band shall be attenuated by at least 20 dB relative to the maximum measured in-band peak PSD level.

Note 2: If the average output power procedure is used to measure the fundamental emission power to demonstrate compliance to requirements, then the power in any 100 kHz outside of the authorized frequency band shall be attenuated by at least 30 dB relative to the maximum measured in-band average PSD level.

#### 3.5.2 Measuring Instruments

Refer a test equipment and calibration data table in this test report.

#### 3.5.3 Test Procedures

| Test Method   |
|---|
| <ul style="list-style-type: none"> <li>Refer as FCC KDB 558074, clause 8.5 for unwanted emissions into non-restricted bands.</li> </ul> |

#### 3.5.4 Test Setup

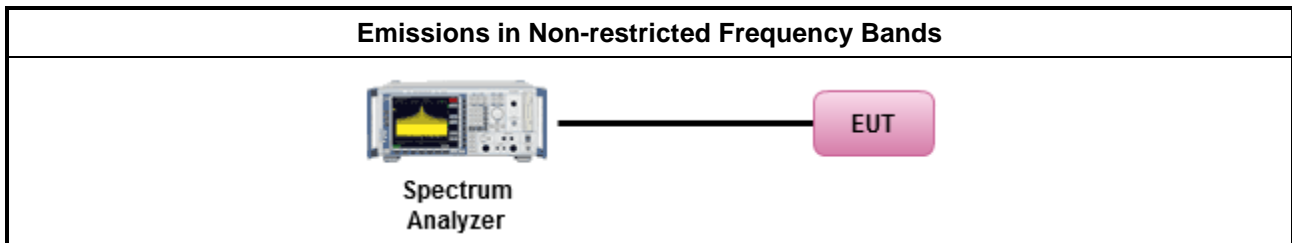

#### 3.5.5 Test Result of Emissions in Non-restricted Frequency Bands

Refer as Appendix E



### 3.6 Emissions in Restricted Frequency Bands

#### 3.6.1 Emissions in Restricted Frequency Bands Limit

| Restricted Band Emissions Limit |                       |                         |                      |
|---------------------------------|-----------------------|-------------------------|----------------------|
| Frequency Range (MHz)           | Field Strength (uV/m) | Field Strength (dBuV/m) | Measure Distance (m) |
| 0.009~0.490                     | 2400/F(kHz)           | 48.5 - 13.8             | 300                  |
| 0.490~1.705                     | 24000/F(kHz)          | 33.8 - 23               | 30                   |
| 1.705~30.0                      | 30                    | 29                      | 30                   |
| 30~88                           | 100                   | 40                      | 3                    |
| 88~216                          | 150                   | 43.5                    | 3                    |
| 216~960                         | 200                   | 46                      | 3                    |
| Above 960                       | 500                   | 54                      | 3                    |

Note 1: Test distance for frequencies at or above 30 MHz, measurements may be performed at a distance other than the limit distance provided they are not performed in the near field and the emissions to be measured can be detected by the measurement equipment. When performing measurements at a distance other than that specified, the results shall be extrapolated to the specified distance using an extrapolation factor of 20 dB/decade (inverse of linear distance for field-strength measurements, inverse of linear distance-squared for power-density measurements).

Note 2: Test distance for frequencies at below 30 MHz, measurements may be performed at a distance closer than the EUT limit distance; however, an attempt should be made to avoid making measurements in the near field. When performing measurements below 30 MHz at a closer distance than the limit distance, the results shall be extrapolated to the specified distance by either making measurements at a minimum of two or more distances on at least one radial to determine the proper extrapolation factor or by using the square of an inverse linear distance extrapolation factor (40 dB/decade). The test report shall specify the extrapolation method used to determine compliance of the EUT.

Note 3: Using the distance of 1m during the test for above 18 GHz, and the test value to correct for the distance factor at 3m.

#### 3.6.2 Measuring Instruments

Refer a test equipment and calibration data table in this test report.





**3.6.3 Test Procedures**

| <b>Test Method</b>  |  |
|---|--|
| <ul style="list-style-type: none"> <li>▪ The average emission levels shall be measured in [duty cycle ≥ 98 or duty factor].</li> </ul>  |  |
| <ul style="list-style-type: none"> <li>▪ Refer as ANSI C63.10, clause 6.10.3 band-edge testing shall be performed at the lowest frequency channel and highest frequency channel within the allowed operating band.</li> </ul> |  |
| <ul style="list-style-type: none"> <li>▪ For the transmitter unwanted emissions shall be measured using following options below:</li> </ul>   |  |
|   | <ul style="list-style-type: none"> <li>▪ Refer as FCC KDB 558074, clause 8.6 for unwanted emissions into restricted bands.</li> </ul>  |
|   | <input type="checkbox"/> Refer as FCC KDB 558074, clause 8.6 & C63.10 clause 11.12.2.5.1(trace averaging for duty cycle ≥98%).   |
|   | <input type="checkbox"/> Refer as FCC KDB 558074, clause 8.6 & C63.10 clause 11.12.2.5.2(trace averaging + duty factor).   |
|   | <input checked="" type="checkbox"/> Refer as FCC KDB 558074, clause 8.6 & C63.10 clause 11.12.2.5.3(Reduced VBW≥1/T).  |
|   | <input type="checkbox"/> Refer as ANSI C63.10, clause 11.12.2.5.3 (Reduced VBW). VBW ≥ 1/T, where T is pulse time.   |
|   | <input type="checkbox"/> Refer as ANSI C63.10, clause 7.5 average value of pulsed emissions.   |
|   | <input checked="" type="checkbox"/> Refer as FCC KDB 558074, clause 8.6 & C63.10 clause 11.12.2.4 measurement procedure peak limit.  |
| <ul style="list-style-type: none"> <li>▪ For the transmitter band-edge emissions shall be measured using following options below:</li> </ul>  |  |
|   | <ul style="list-style-type: none"> <li>▪ Refer as FCC KDB 558074 clause 8.7 &amp; C63.10 clause 11.13.1, When the performing peak or average radiated measurements, emissions within 2 MHz of the authorized band edge may be measured using the marker-delta method described below.</li> </ul>   |
|   | <ul style="list-style-type: none"> <li>▪ Refer as FCC KDB 558074, clause 8.7 (ANSI C63.10, clause 6.10.6) for marker-delta method for band-edge measurements.</li> </ul>   |
|   | <ul style="list-style-type: none"> <li>▪ Refer as FCC KDB 558074, clause 8.7 for narrower resolution bandwidth (100kHz) using the band power and summing the spectral levels (i.e., 1 MHz).</li> </ul>   |
|   | <ul style="list-style-type: none"> <li>▪ For conducted unwanted emissions into restricted bands (absolute emission limits). Devices with multiple transmit chains using options given below:<br/>               (1) Measure and sum the spectra across the outputs or<br/>               (2) Measure and add 10 log(N) dB             </li> </ul>  |
|   | <ul style="list-style-type: none"> <li>▪ For FCC KDB 662911 The methodology described here may overestimate array gain, thereby resulting in apparent failures to satisfy the out-of-band limits even if the device is actually compliant. In such cases, compliance may be demonstrated by performing radiated tests around the frequencies at which the apparent failures occurred.</li> </ul> |

**3.6.4 Test Setup**

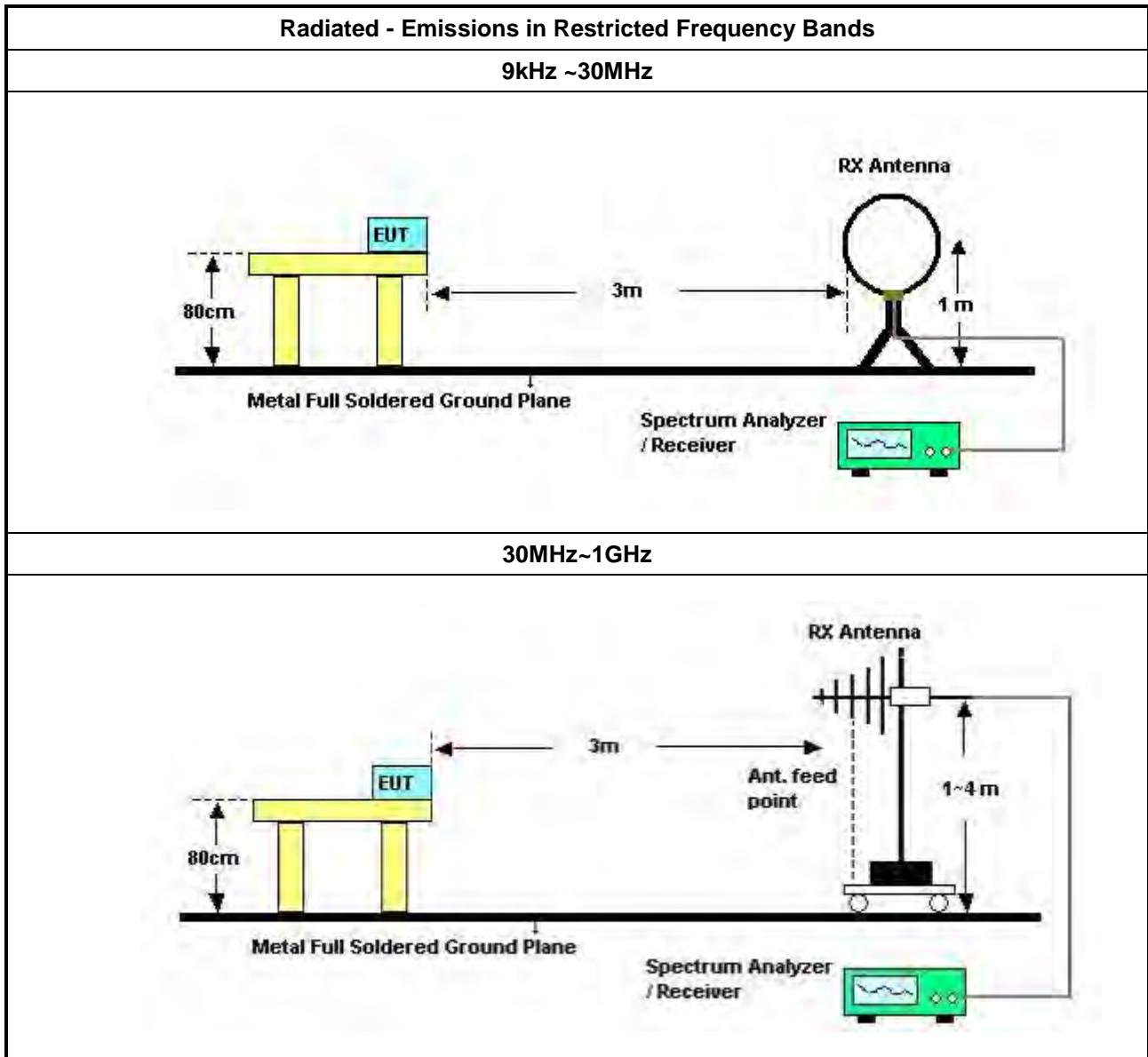

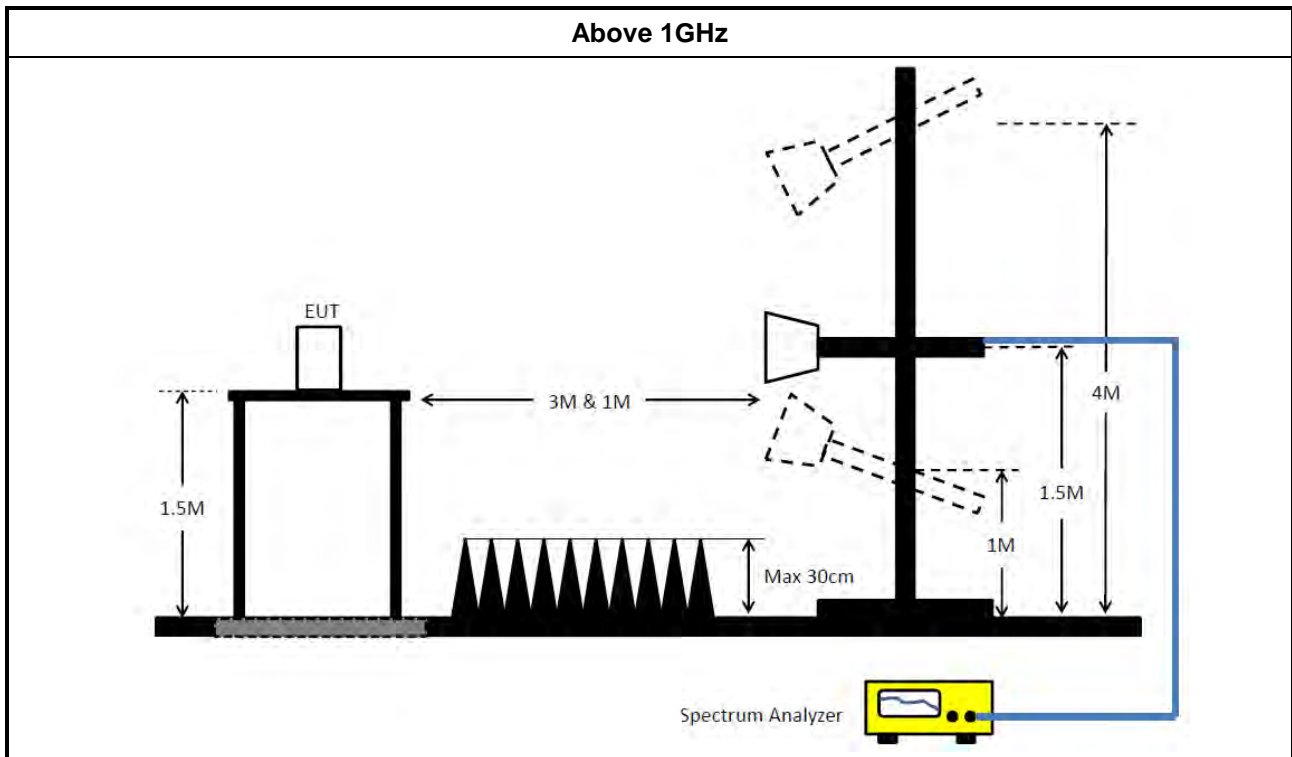

### 3.6.5 Measurement Results Calculation

The measured Level is calculated using:

Corrected Reading: Antenna factor (AF) + Cable loss (CL) + Read level (Raw) - Preamp factor (PA)(if applicable) = Level.

### 3.6.6 Emissions in Restricted Frequency Bands (Below 30MHz)

There is a comparison data of both open-field test site and alternative test site - semi-Anechoic chamber according to KDB414788 Radiated Test Site, and the result came out very similar.

All amplitude of spurious emissions that are attenuated by more than 20 dB below the permissible value has no need to be reported.

The radiated emissions were investigated from 9 kHz or the lowest frequency generated within the device, up to the 10th harmonic or 40 GHz, whichever is appropriate.

### 3.6.7 Test Result of Emissions in Restricted Frequency Bands

Refer as Appendix F



## 4 Test Equipment and Calibration Data

| Instrument                         | Brand           | Model No.         | Serial No.       | Characteristics   | Calibration Date | Calibration Due Date | Remark                |
|------------------------------------|-----------------|-------------------|------------------|-------------------|------------------|----------------------|-----------------------|
| EMI Receiver                       | Agilent         | N9038A            | My52260123       | 9kHz ~ 8.4GHz     | Feb. 20, 2023    | Feb. 19, 2024        | Conduction (CO01-CB)  |
| LISN                               | F.C.C.          | FCC-LISN-50-16-2  | 04083            | 150kHz ~ 100MHz   | Feb. 16, 2023    | Feb. 15, 2024        | Conduction (CO01-CB)  |
| LISN                               | Schwarzbeck     | NSLK 8127         | 8127647          | 9kHz ~ 30MHz      | Apr. 27, 2023    | Apr. 26, 2024        | Conduction (CO01-CB)  |
| Pulse Limiter                      | Rohde&Schwarz   | ESH3-Z2           | 100430           | 9kHz ~ 30MHz      | Feb. 09, 2023    | Feb. 08, 2024        | Conduction (CO01-CB)  |
| COND Cable                         | Woken           | Cable             | Low cable-CO01   | 9kHz ~ 30MHz      | Oct. 18, 2022    | Oct. 17, 2023        | Conduction (CO01-CB)  |
| Software                           | SPORTON         | SENSE             | V5.10            | -                 | N.C.R.           | N.C.R.               | Conduction (CO01-CB)  |
| Loop Antenna                       | Teseq           | HLA 6120          | 31244            | 9kHz - 30 MHz     | Mar. 23, 2023    | Mar. 22, 2024        | Radiation (03CH03-CB) |
| 3m Semi Anechoic Chamber NSA       | TDK             | SAC-3M            | 03CH03-CB        | 30 MHz ~ 1 GHz    | Jan. 17, 2023    | Jan. 16, 2024        | Radiation (03CH03-CB) |
| 3m Semi Anechoic Chamber VSWR      | TDK             | SAC-3M            | 03CH03-CB        | 1GHz ~18GHz<br>3m | May 04, 2023     | May 03, 2024         | Radiation (03CH03-CB) |
| Bilog Antenna with 6 dB attenuator | Schaffner & EMC | CBL6112B & N-6-06 | 2928 & AT-N0608  | 20MHz ~ 2GHz      | Feb. 19, 2023    | Feb. 18, 2024        | Radiation (03CH03-CB) |
| Horn Antenna                       | ETS · Lindgren  | 3115              | 6821             | 750MHz~18GHz      | Feb. 03, 2023    | Feb. 02, 2024        | Radiation (03CH03-CB) |
| Horn Antenna                       | SCHWARZBECK     | BBHA 9170         | BBHA9170507      | 15GHz ~ 40GHz     | Jun. 28, 2023    | Jun. 27, 2024        | Radiation (03CH03-CB) |
| Pre-Amplifier                      | Agilent         | 8447D             | 2944A10259       | 9kHz ~ 1.3GHz     | Jan. 09, 2023    | Jan. 08, 2024        | Radiation (03CH03-CB) |
| Pre-Amplifier                      | Agilent         | 8449B             | 3008A02097       | 1GHz ~ 26.5GHz    | Jun. 30, 2023    | Jun. 29, 2024        | Radiation (03CH03-CB) |
| Pre-Amplifier                      | SGH             | SGH184            | 20221107-3       | 18GHz ~ 40GHz     | Nov. 16, 2022    | Nov. 15, 2023        | Radiation (03CH03-CB) |
| Spectrum Analyzer                  | R&S             | FSP40             | 100019           | 9kHz ~ 40GHz      | Jun. 12, 2023    | Jun. 11, 2024        | Radiation (03CH03-CB) |
| EMI Test Receiver                  | R&S             | ESCS              | 826547/017       | 9kHz ~ 2.75GHz    | Jun. 13, 2023    | Jun. 12, 2024        | Radiation (03CH03-CB) |
| RF Cable-low                       | Woken           | RG402             | Low Cable-02+29  | 30MHz ~ 1GHz      | Oct. 03, 2022    | Oct. 02, 2023        | Radiation (03CH03-CB) |
| RF Cable-high                      | Woken           | RG402             | High Cable-20+29 | 1GHz ~ 18GHz      | Oct. 03, 2022    | Oct. 02, 2023        | Radiation (03CH03-CB) |
| RF Cable-high                      | Woken           | RG402             | High Cable-29    | 1GHz ~ 18GHz      | Oct. 03, 2022    | Oct. 02, 2023        | Radiation (03CH03-CB) |
| High Cable                         | Woken           | WCA0929M          | 40G#5+6          | 1GHz ~ 40 GHz     | Dec. 07, 2022    | Dec. 06, 2023        | Radiation (03CH03-CB) |
| High Cable                         | Woken           | WCA0929M          | 40G#5            | 1GHz ~ 40 GHz     | Dec. 07, 2022    | Dec. 06, 2023        | Radiation (03CH03-CB) |
| High Cable                         | Woken           | WCA0929M          | 40G#6            | 1GHz ~ 40 GHz     | Dec. 07, 2022    | Dec. 06, 2023        | Radiation (03CH03-CB) |
| Test Software                      | SPORTON         | SENSE             | V5.10            | -                 | N.C.R.           | N.C.R.               | Radiation (03CH03-CB) |



| Instrument        | Brand   | Model No. | Serial No.    | Characteristics | Calibration Date | Calibration Due Date | Remark              |
|-------------------|---------|-----------|---------------|-----------------|------------------|----------------------|---------------------|
| Spectrum analyzer | R&S     | FSV40     | 101027        | 9kHz~40GHz      | Aug. 14, 2023    | Aug. 13, 2024        | Conducted (TH02-CB) |
| Power Sensor      | Anritsu | MA2411B   | 1126203       | 300MHz~40GHz    | Oct. 17, 2022    | Oct. 16, 2023        | Conducted (TH02-CB) |
| Power Meter       | Anritsu | ML2495A   | 1210004       | 300MHz~40GHz    | Oct. 17, 2022    | Oct. 16, 2023        | Conducted (TH02-CB) |
| RF Cable-high     | Woken   | RG402     | High Cable-01 | 1 GHz – 18 GHz  | Oct. 03, 2022    | Oct. 02, 2023        | Conducted (TH02-CB) |
| RF Cable-high     | Woken   | RG402     | High Cable-02 | 1 GHz – 18 GHz  | Oct. 03, 2022    | Oct. 02, 2023        | Conducted (TH02-CB) |
| RF Cable-high     | Woken   | RG402     | High Cable-03 | 1 GHz – 18 GHz  | Oct. 03, 2022    | Oct. 02, 2023        | Conducted (TH02-CB) |
| RF Cable-high     | Woken   | RG402     | High Cable-04 | 1 GHz – 18 GHz  | Oct. 03, 2022    | Oct. 02, 2023        | Conducted (TH02-CB) |
| RF Cable-high     | Woken   | RG402     | High Cable-05 | 1 GHz – 18 GHz  | Oct. 03, 2022    | Oct. 02, 2023        | Conducted (TH02-CB) |
| Switch            | SPTCB   | SP-SWI    | SWI-02        | 1 GHz ~26.5 GHz | Oct. 04, 2022    | Oct. 03, 2023        | Conducted (TH02-CB) |
| Test Software     | SPORTON | SENSE     | V5.10         | -               | N.C.R.           | N.C.R.               | Conducted (TH02-CB) |

Note: Calibration Interval of instruments listed above is one year.

N.C.R. means Non-Calibration required.



**Summary**

| Mode   | Result | Type | Freq (Hz) | Level (dBuV) | Limit (dBuV) | Margin (dB) | Condition |
|--------|--------|------|-----------|--------------|--------------|-------------|-----------|
| Mode 3 | Pass   | AV   | 451.5k    | 36.09        | 46.84        | -10.75      | Neutral   |

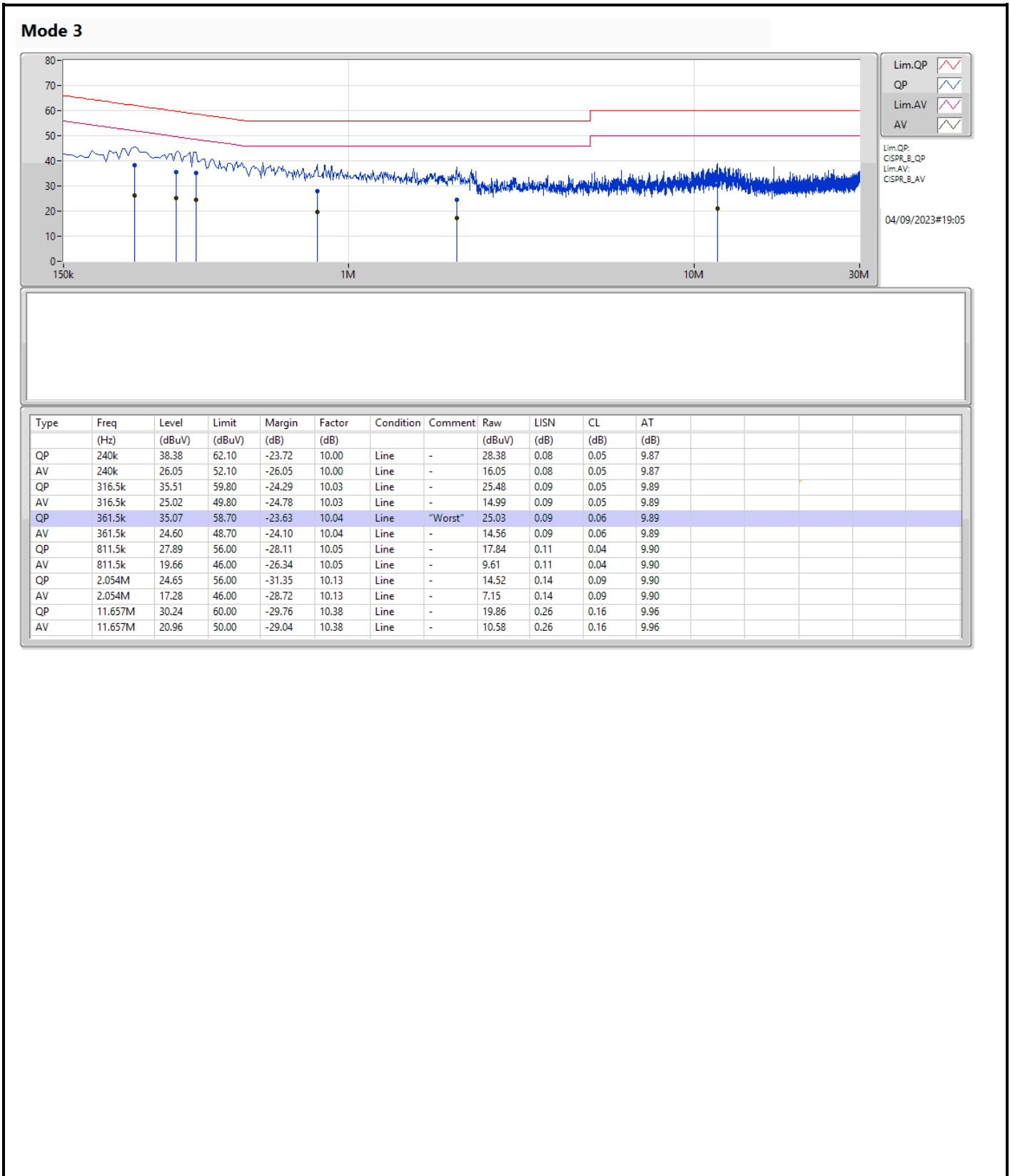

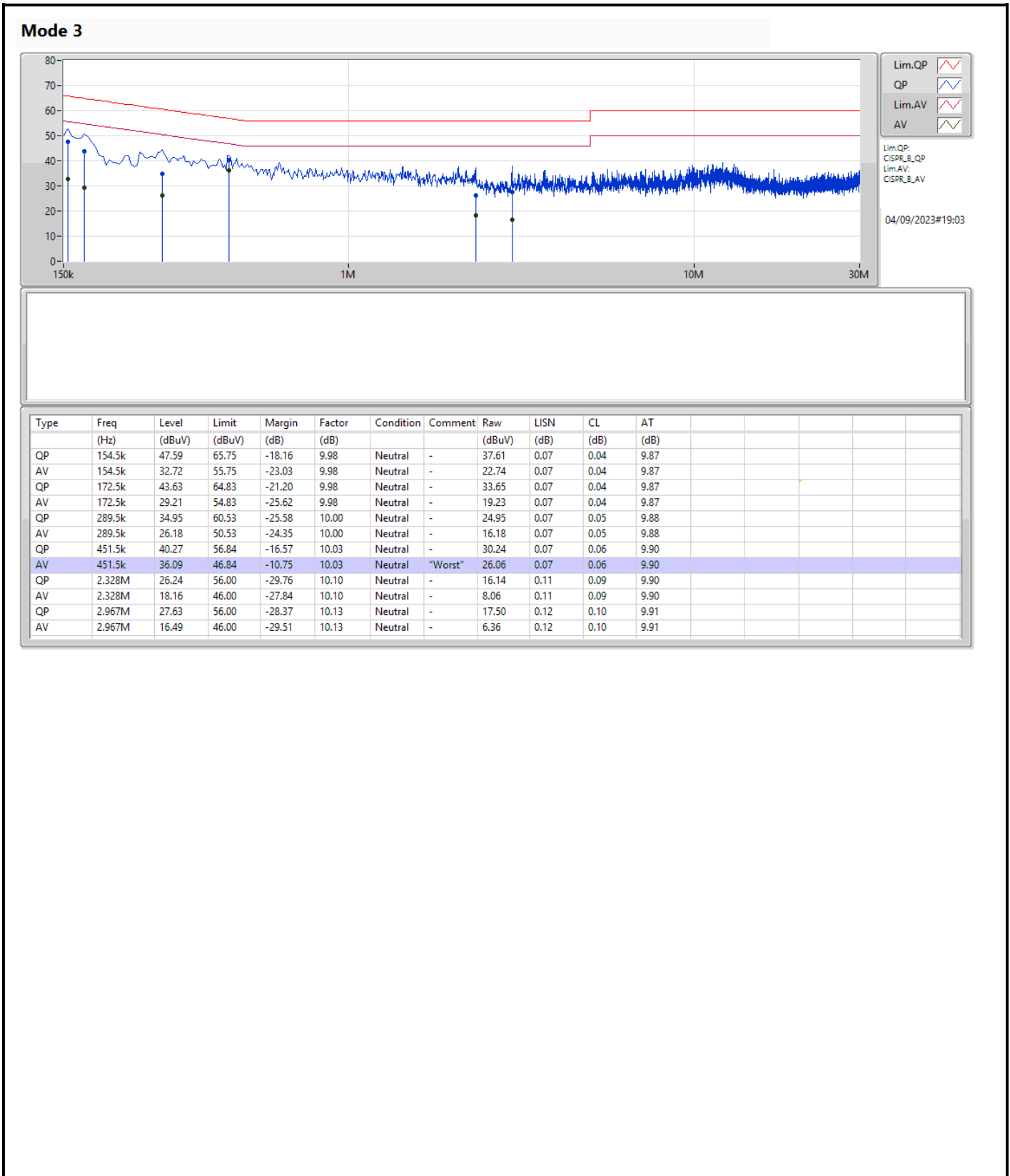





Summary

| Mode                         | Max-N dB (Hz) | Max-OBW (Hz) | ITU-Code | Min-N dB (Hz) | Min-OBW (Hz) |
|------------------------------|---------------|--------------|----------|---------------|--------------|
| 2.4-2.4835GHz                | -             | -            | -        | -             | -            |
| 802.11b_Nss1,(1Mbps)_1TX     | 10.075M       | 15.442M      | 15M4G1D  | 10.05M        | 15.164M      |
| 802.11g_Nss1,(6Mbps)_1TX     | 16.325M       | 18.026M      | 18M0D1D  | 16.3M         | 16.822M      |
| 802.11n HT20_Nss1,(MCS0)_1TX | 17.525M       | 18.587M      | 18M6D1D  | 17.025M       | 17.782M      |
| 802.11n HT40_Nss1,(MCS0)_1TX | 36.3M         | 36.656M      | 36M7D1D  | 35.65M        | 36.542M      |

Max-N dB = Maximum 6dB down bandwidth; Max-OBW = Maximum 99% occupied bandwidth;  
Min-N dB = Minimum 6dB down bandwidth; Min-OBW = Minimum 99% occupied bandwidth

**Result**

| Mode                         | Result | Limit (Hz) | Port 1-N dB (Hz) | Port 1-OBW (Hz) |
|------------------------------|--------|------------|------------------|-----------------|
| 802.11b_Nss1,(1Mbps)_1TX     | -      | -          | -                | -               |
| 2412MHz                      | Pass   | 500k       | 10.05M           | 15.442M         |
| 2437MHz                      | Pass   | 500k       | 10.05M           | 15.298M         |
| 2462MHz                      | Pass   | 500k       | 10.075M          | 15.164M         |
| 802.11g_Nss1,(6Mbps)_1TX     | -      | -          | -                | -               |
| 2412MHz                      | Pass   | 500k       | 16.3M            | 16.863M         |
| 2437MHz                      | Pass   | 500k       | 16.3M            | 18.026M         |
| 2462MHz                      | Pass   | 500k       | 16.325M          | 16.822M         |
| 802.11n HT20_Nss1,(MCS0)_1TX | -      | -          | -                | -               |
| 2412MHz                      | Pass   | 500k       | 17.525M          | 17.782M         |
| 2437MHz                      | Pass   | 500k       | 17.275M          | 18.587M         |
| 2462MHz                      | Pass   | 500k       | 17.025M          | 17.823M         |
| 802.11n HT40_Nss1,(MCS0)_1TX | -      | -          | -                | -               |
| 2422MHz                      | Pass   | 500k       | 36.3M            | 36.542M         |
| 2437MHz                      | Pass   | 500k       | 35.8M            | 36.629M         |
| 2452MHz                      | Pass   | 500k       | 35.65M           | 36.656M         |

Port X-N dB = Port X 6dB down bandwidth;  
 Port X-OBW = Port X 99% occupied bandwidth

2.4-2.4835GHz\_802.11b\_Nss1,(1Mbps)\_1TX

EBW

2412MHz

04/09/2023

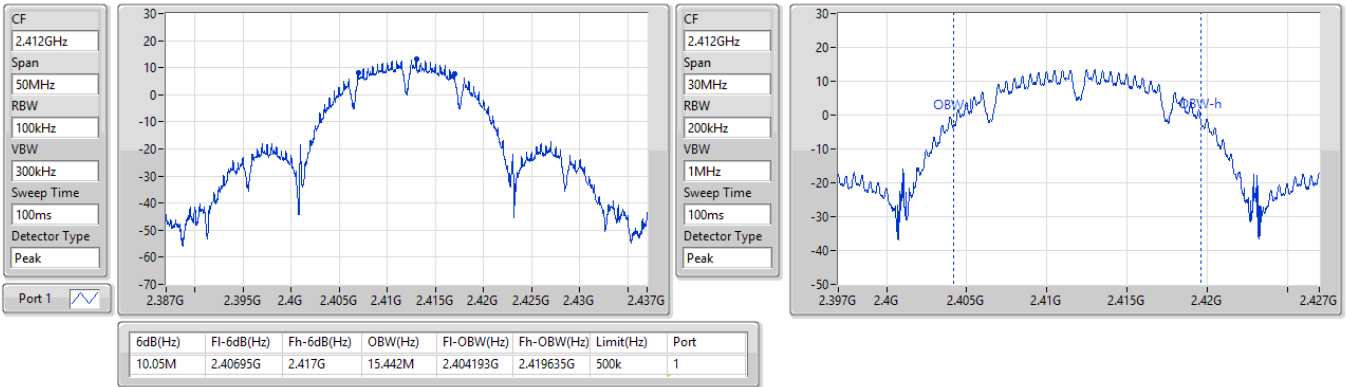

2.4-2.4835GHz\_802.11b\_Nss1,(1Mbps)\_1TX

EBW

2437MHz

04/09/2023

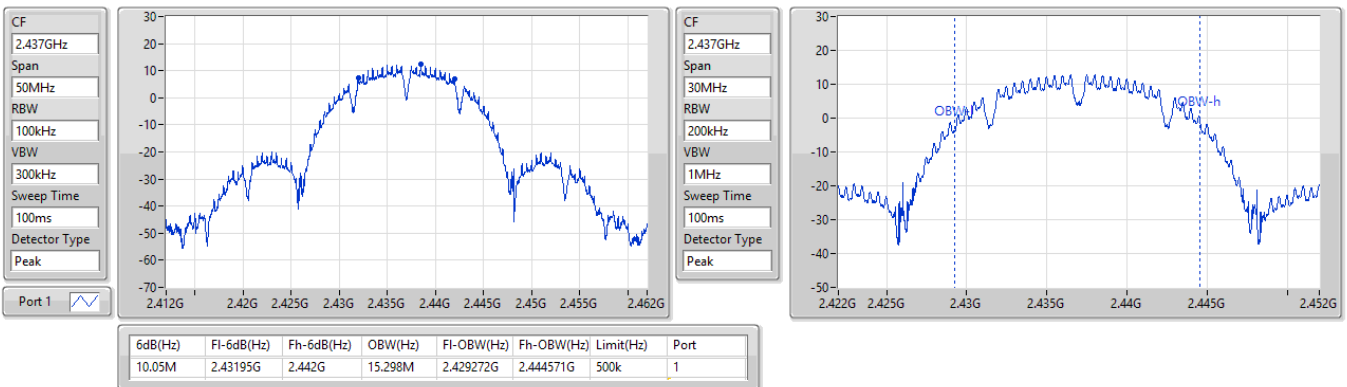

2.4-2.4835GHz\_802.11b\_Nss1,(1Mbps)\_1TX

EBW

2462MHz

04/09/2023

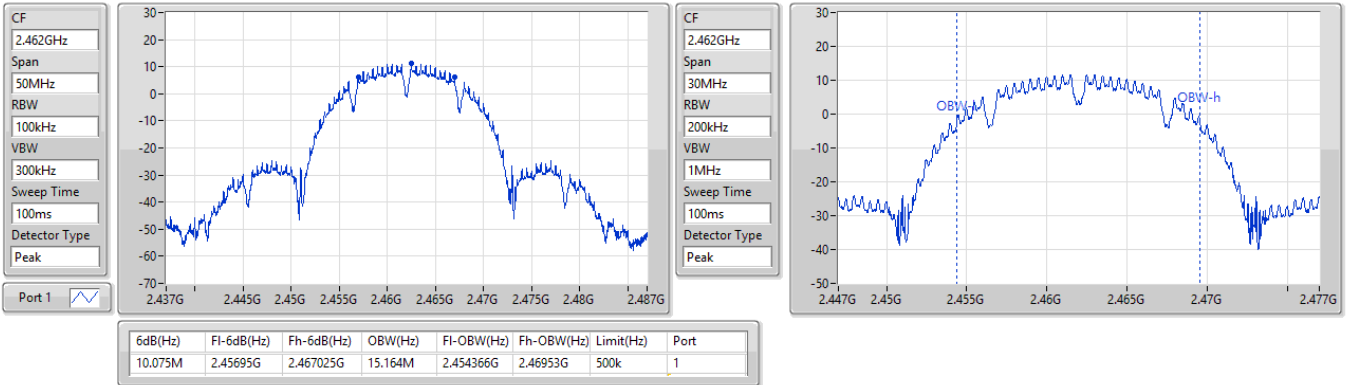

2.4-2.4835GHz\_802.11g\_Nss1,(6Mbps)\_1TX

EBW

2412MHz

04/09/2023

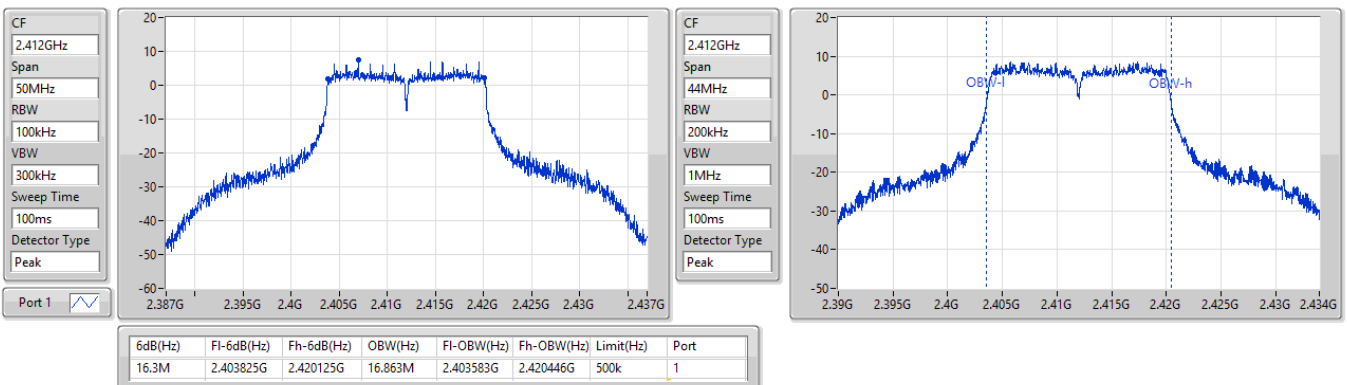

2.4-2.4835GHz\_802.11g\_Nss1,(6Mbps)\_1TX

EBW

2437MHz

04/09/2023

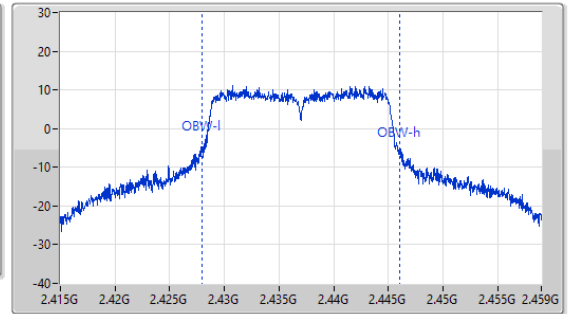
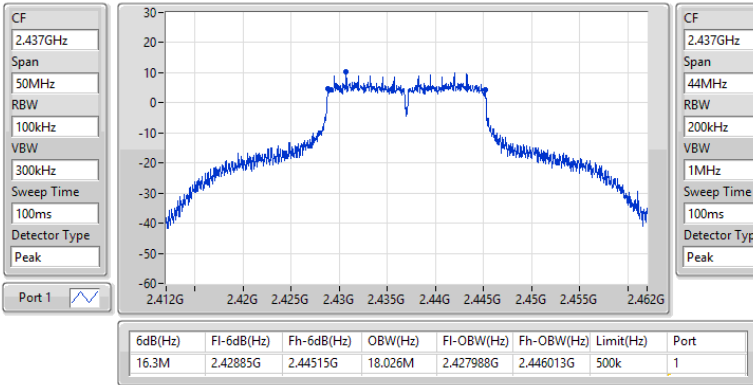

2.4-2.4835GHz\_802.11g\_Nss1,(6Mbps)\_1TX

EBW

2462MHz

04/09/2023

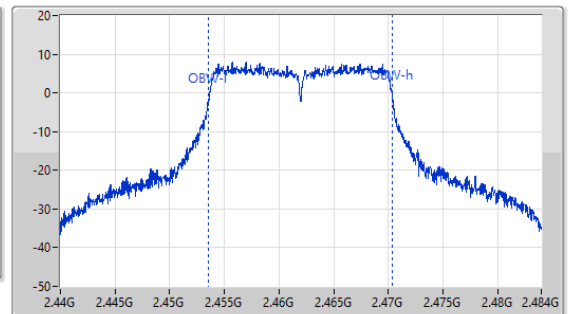
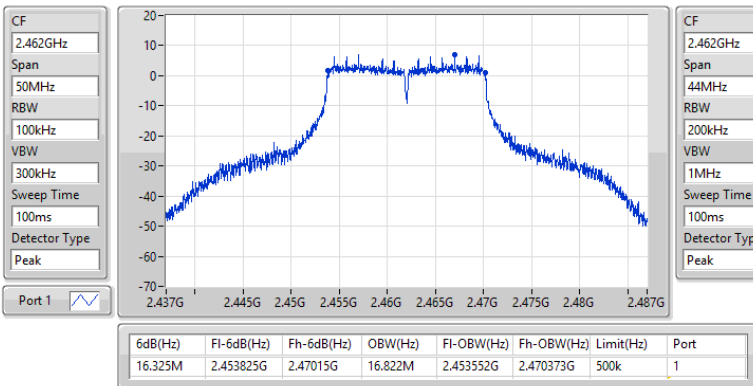

2.4-2.4835GHz\_802.11n\_HT20\_Nss1,(MCS0)\_1TX

EBW

2412MHz

04/09/2023

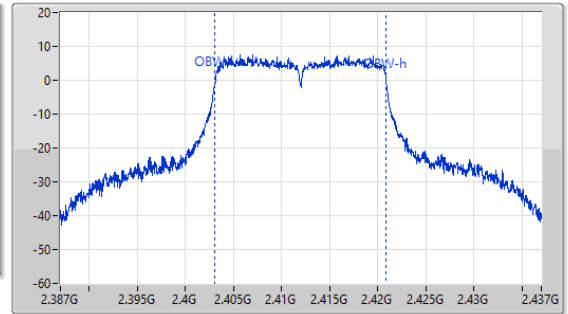
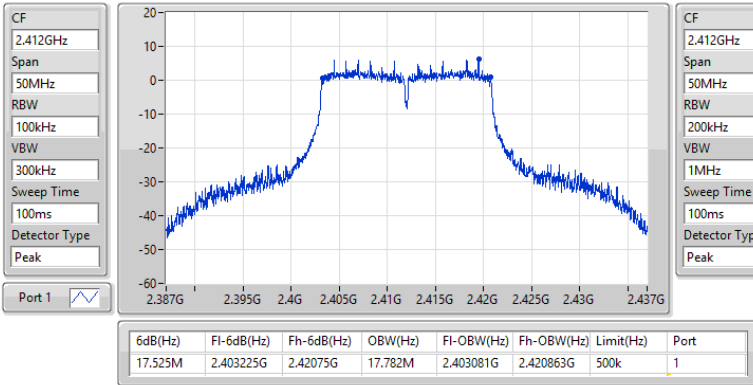

2.4-2.4835GHz\_802.11n\_HT20\_Nss1,(MCS0)\_1TX

EBW

2437MHz

04/09/2023

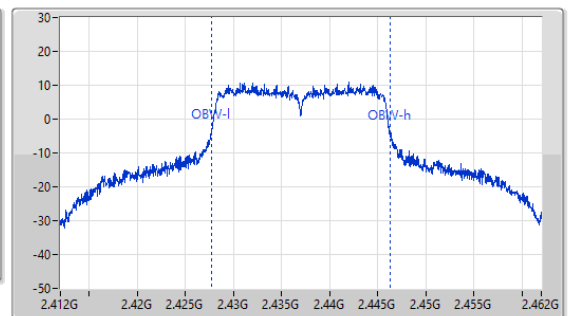
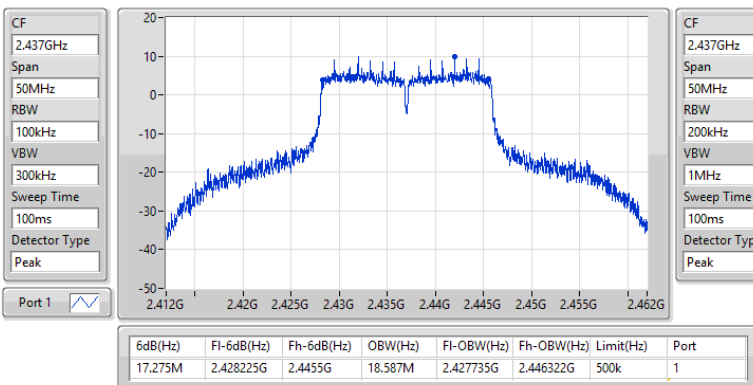

2.4-2.4835GHz\_802.11n HT20\_Nss1,(MCS0)\_1TX

EBW

2462MHz

04/09/2023

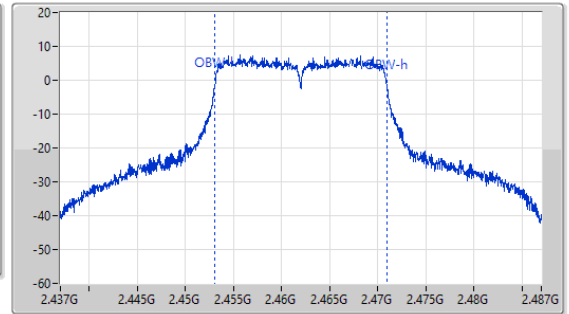
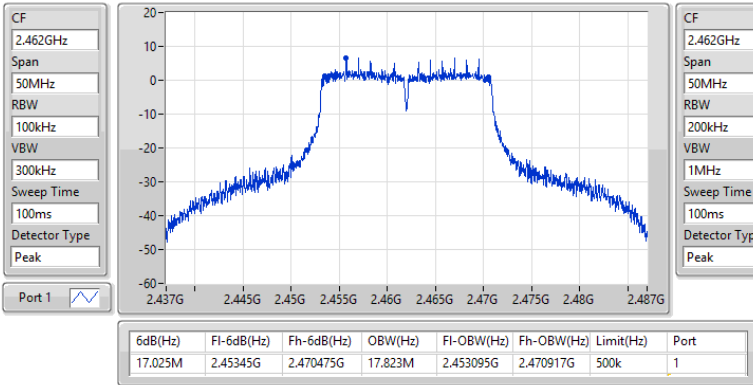

2.4-2.4835GHz\_802.11n HT40\_Nss1,(MCS0)\_1TX

EBW

2422MHz

04/09/2023

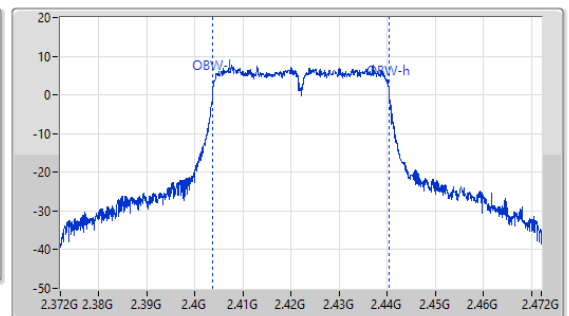
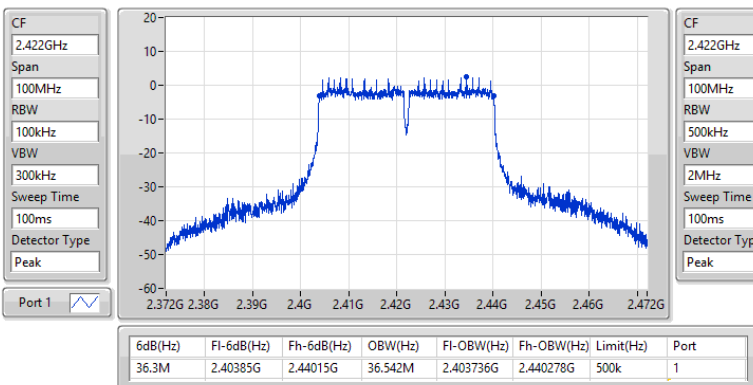

2.4-2.4835GHz\_802.11n HT40\_Nss1,(MCS0)\_1TX

EBW

2437MHz

04/09/2023

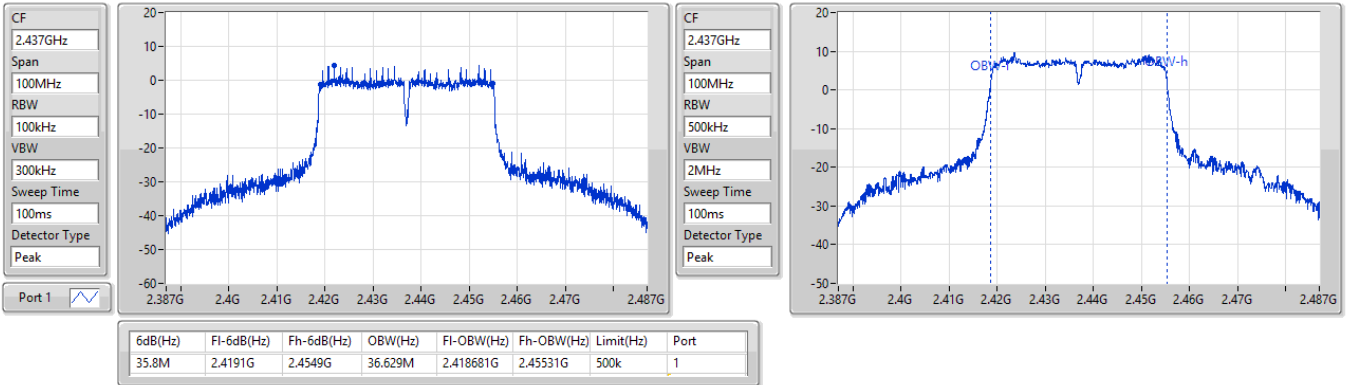

2.4-2.4835GHz\_802.11n HT40\_Nss1,(MCS0)\_1TX

EBW

2452MHz

04/09/2023

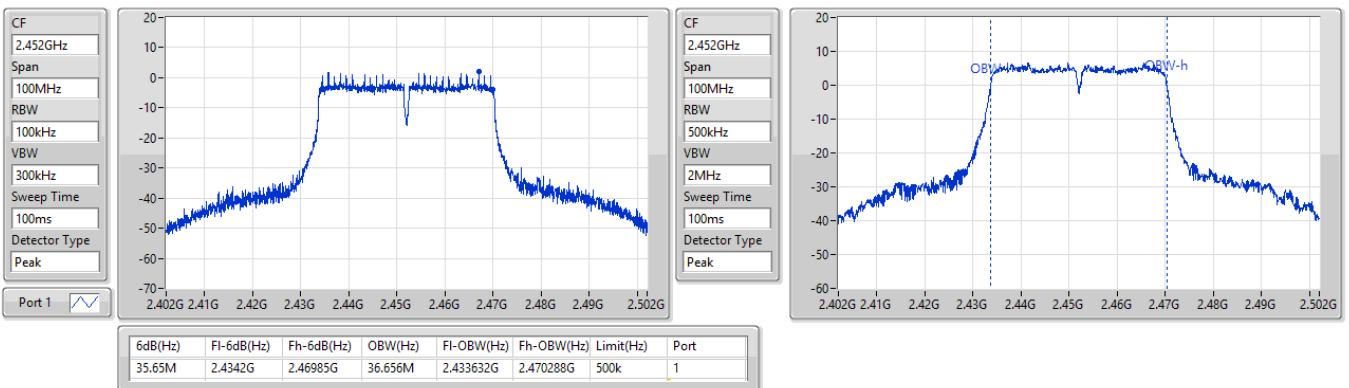





**Summary**

| Mode                         | Total Power (dBm) | Total Power (W) |
|------------------------------|-------------------|-----------------|
| 2.4-2.4835GHz                | -                 | -               |
| 802.11b_Nss1,(1Mbps)_1TX     | 22.34             | 0.17140         |
| 802.11g_Nss1,(6Mbps)_1TX     | 20.54             | 0.11324         |
| 802.11n HT20_Nss1,(MCS0)_1TX | 20.40             | 0.10965         |
| 802.11n HT40_Nss1,(MCS0)_1TX | 17.92             | 0.06194         |



Result

| Mode                         | Result | DG (dBi) | Port 1 (dBm) | Total Power (dBm) | Power Limit (dBm) |
|------------------------------|--------|----------|--------------|-------------------|-------------------|
| 802.11b_Nss1,(1Mbps)_1TX     | -      | -        | -            | -                 | -                 |
| 2412MHz                      | Pass   | 2.42     | 22.34        | 22.34             | 30.00             |
| 2437MHz                      | Pass   | 2.42     | 21.76        | 21.76             | 30.00             |
| 2462MHz                      | Pass   | 2.42     | 20.61        | 20.61             | 30.00             |
| 802.11g_Nss1,(6Mbps)_1TX     | -      | -        | -            | -                 | -                 |
| 2412MHz                      | Pass   | 2.42     | 18.21        | 18.21             | 30.00             |
| 2417MHz                      | Pass   | 2.42     | 20.54        | 20.54             | 30.00             |
| 2437MHz                      | Pass   | 2.42     | 20.41        | 20.41             | 30.00             |
| 2457MHz                      | Pass   | 2.42     | 20.43        | 20.43             | 30.00             |
| 2462MHz                      | Pass   | 2.42     | 17.80        | 17.80             | 30.00             |
| 802.11n HT20_Nss1,(MCS0)_1TX | -      | -        | -            | -                 | -                 |
| 2412MHz                      | Pass   | 2.42     | 17.30        | 17.30             | 30.00             |
| 2417MHz                      | Pass   | 2.42     | 20.40        | 20.40             | 30.00             |
| 2437MHz                      | Pass   | 2.42     | 20.31        | 20.31             | 30.00             |
| 2457MHz                      | Pass   | 2.42     | 20.34        | 20.34             | 30.00             |
| 2462MHz                      | Pass   | 2.42     | 17.32        | 17.32             | 30.00             |
| 802.11n HT40_Nss1,(MCS0)_1TX | -      | -        | -            | -                 | -                 |
| 2422MHz                      | Pass   | 2.42     | 16.52        | 16.52             | 30.00             |
| 2427MHz                      | Pass   | 2.42     | 16.61        | 16.61             | 30.00             |
| 2437MHz                      | Pass   | 2.42     | 17.92        | 17.92             | 30.00             |
| 2447MHz                      | Pass   | 2.42     | 16.28        | 16.28             | 30.00             |
| 2452MHz                      | Pass   | 2.42     | 15.65        | 15.65             | 30.00             |

DG = Directional Gain; Port X = Port X output power



Summary

| Mode                         | PD<br>(dBm/RBW) |
|------------------------------|-----------------|
| 2.4-2.4835GHz                | -               |
| 802.11b_Nss1,(1Mbps)_1TX     | -1.53           |
| 802.11g_Nss1,(6Mbps)_1TX     | -4.86           |
| 802.11n HT20_Nss1,(MCS0)_1TX | -5.88           |
| 802.11n HT40_Nss1,(MCS0)_1TX | -10.69          |

RBW = 3kHz;

Result

| Mode                         | Result | DG<br>(dBi) | Port 1<br>(dBm/RBW) | PD<br>(dBm/RBW) | PD Limit<br>(dBm/RBW) |
|------------------------------|--------|-------------|---------------------|-----------------|-----------------------|
| 802.11b_Nss1,(1Mbps)_1TX     | -      | -           | -                   | -               | -                     |
| 2412MHz                      | Pass   | 2.42        | -1.53               | -1.53           | 8.00                  |
| 2437MHz                      | Pass   | 2.42        | -1.93               | -1.93           | 8.00                  |
| 2462MHz                      | Pass   | 2.42        | -3.41               | -3.41           | 8.00                  |
| 802.11g_Nss1,(6Mbps)_1TX     | -      | -           | -                   | -               | -                     |
| 2412MHz                      | Pass   | 2.42        | -8.29               | -8.29           | 8.00                  |
| 2437MHz                      | Pass   | 2.42        | -4.86               | -4.86           | 8.00                  |
| 2462MHz                      | Pass   | 2.42        | -8.36               | -8.36           | 8.00                  |
| 802.11n HT20_Nss1,(MCS0)_1TX | -      | -           | -                   | -               | -                     |
| 2412MHz                      | Pass   | 2.42        | -8.24               | -8.24           | 8.00                  |
| 2437MHz                      | Pass   | 2.42        | -5.88               | -5.88           | 8.00                  |
| 2462MHz                      | Pass   | 2.42        | -9.34               | -9.34           | 8.00                  |
| 802.11n HT40_Nss1,(MCS0)_1TX | -      | -           | -                   | -               | -                     |
| 2422MHz                      | Pass   | 2.42        | -12.13              | -12.13          | 8.00                  |
| 2437MHz                      | Pass   | 2.42        | -10.69              | -10.69          | 8.00                  |
| 2452MHz                      | Pass   | 2.42        | -13.17              | -13.17          | 8.00                  |

DG = Directional Gain; RBW = 3kHz;  
 PD = trace bin-by-bin of each transmits port summing can be performed maximum power density; Port X = Port X Power Density;

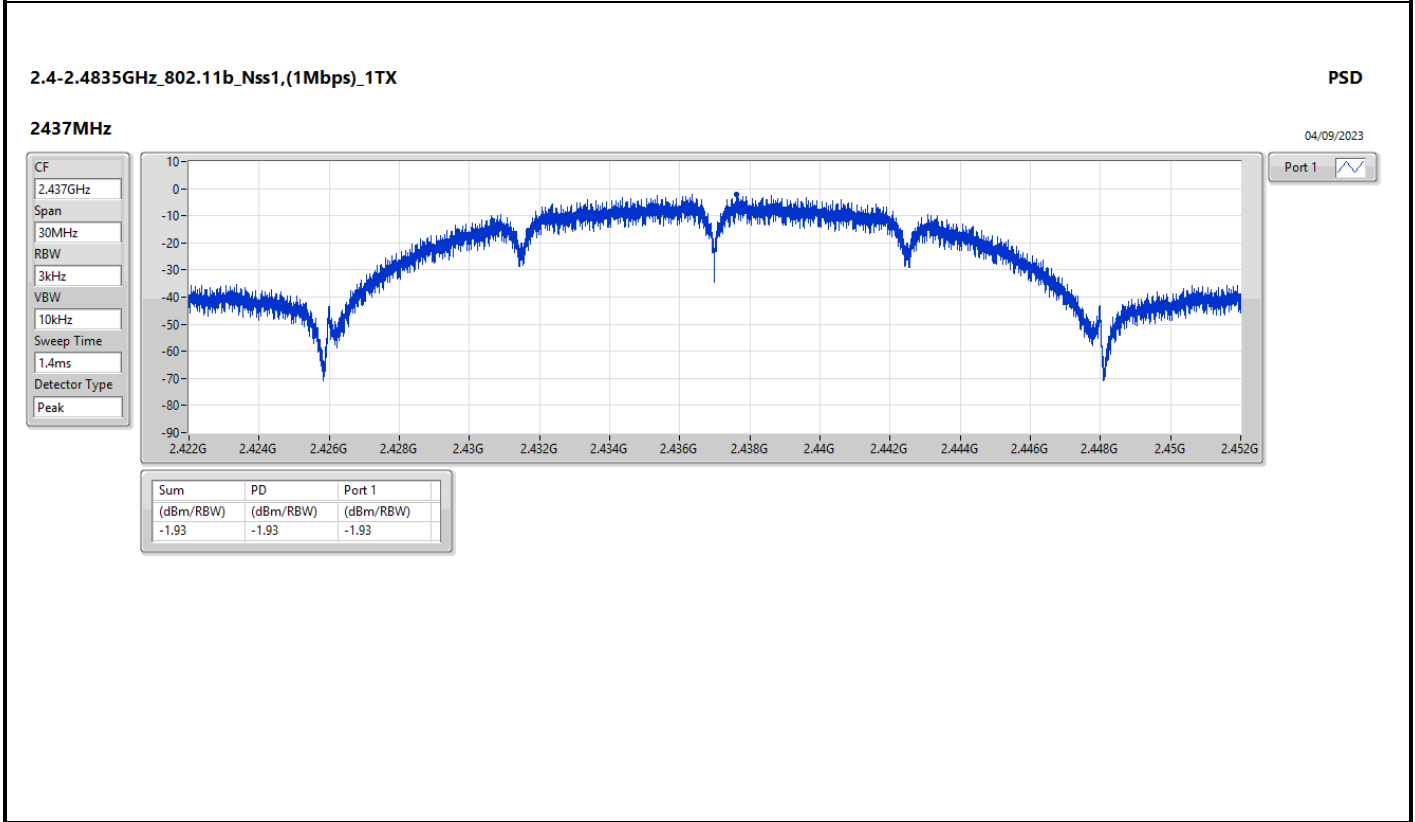
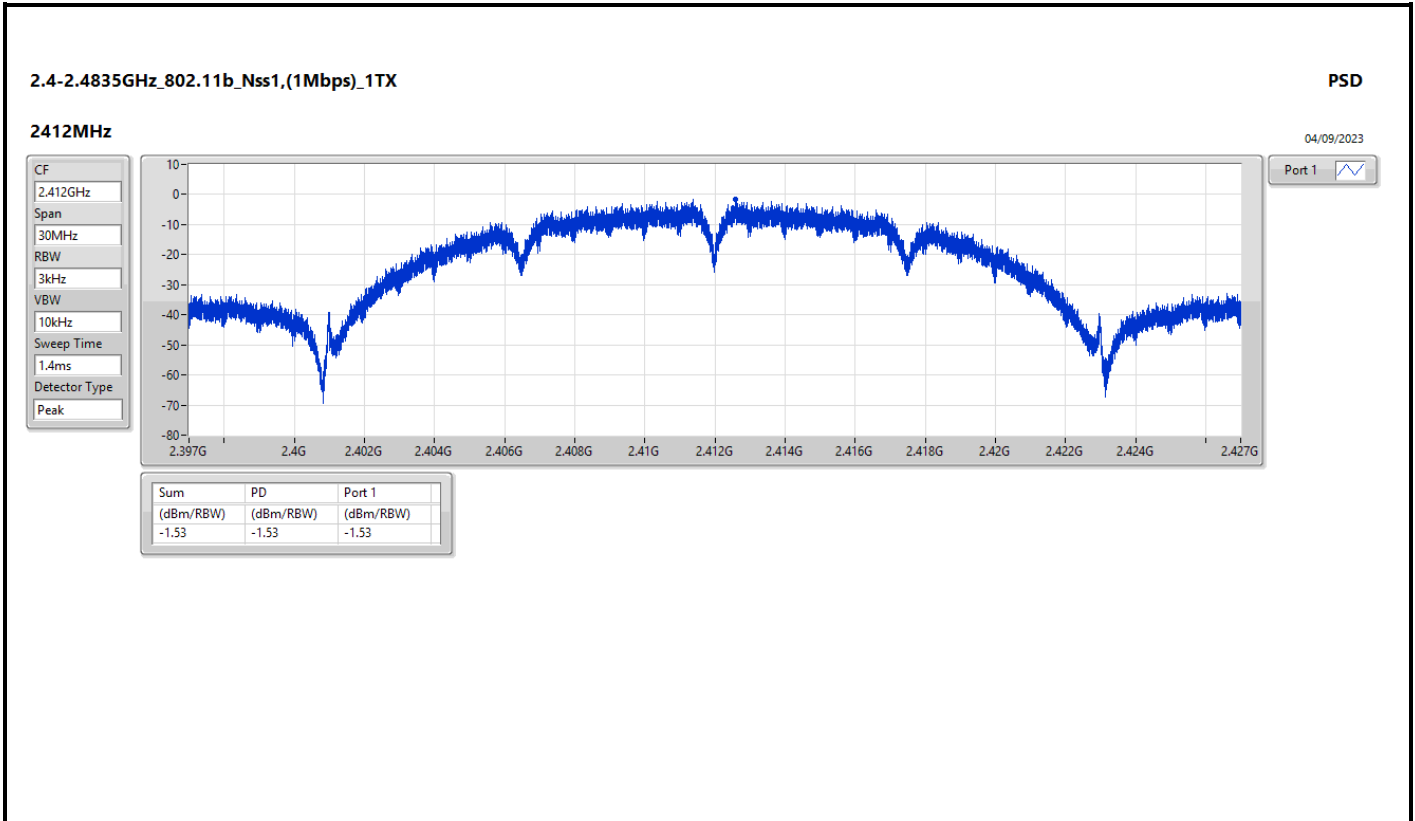

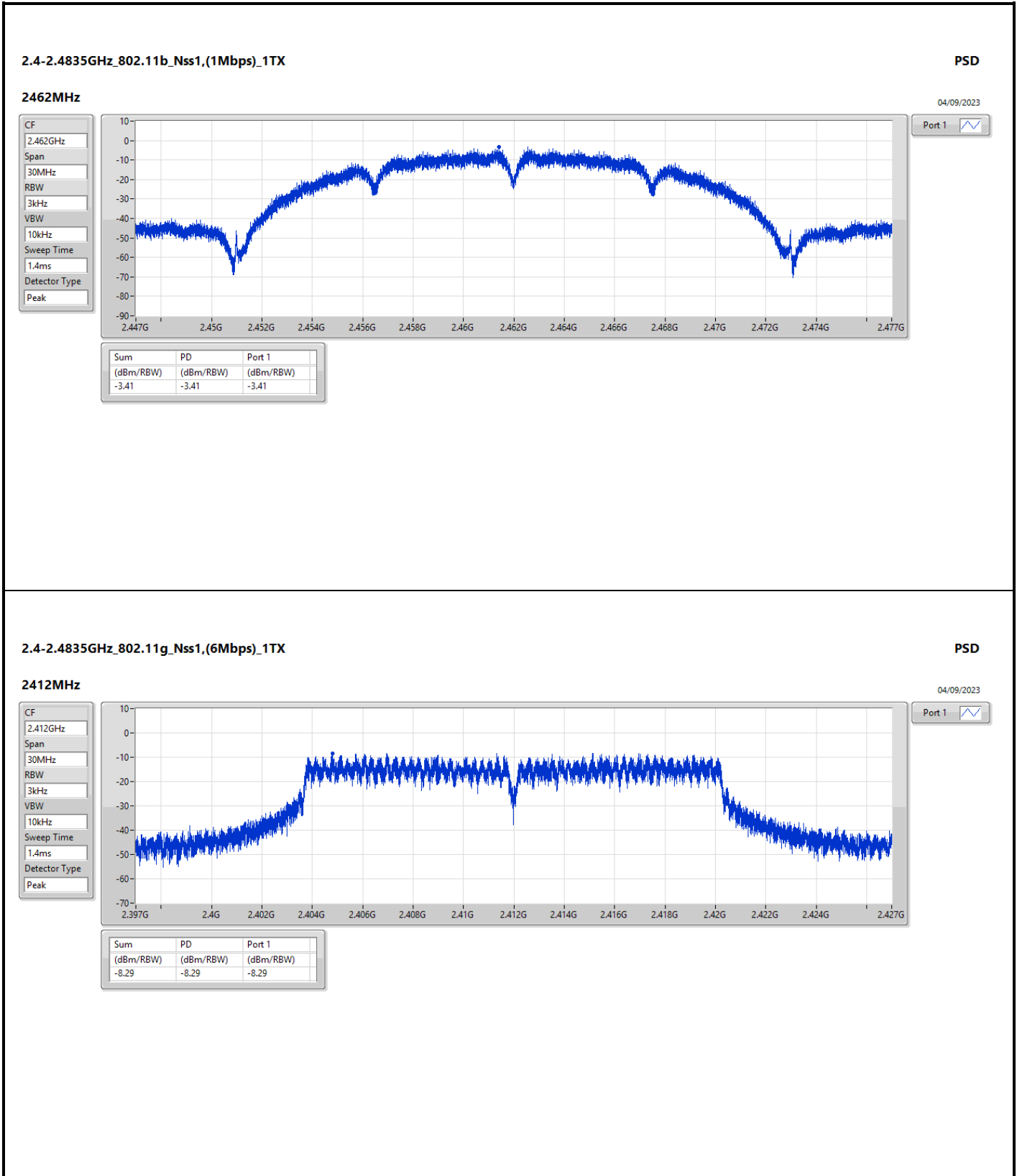

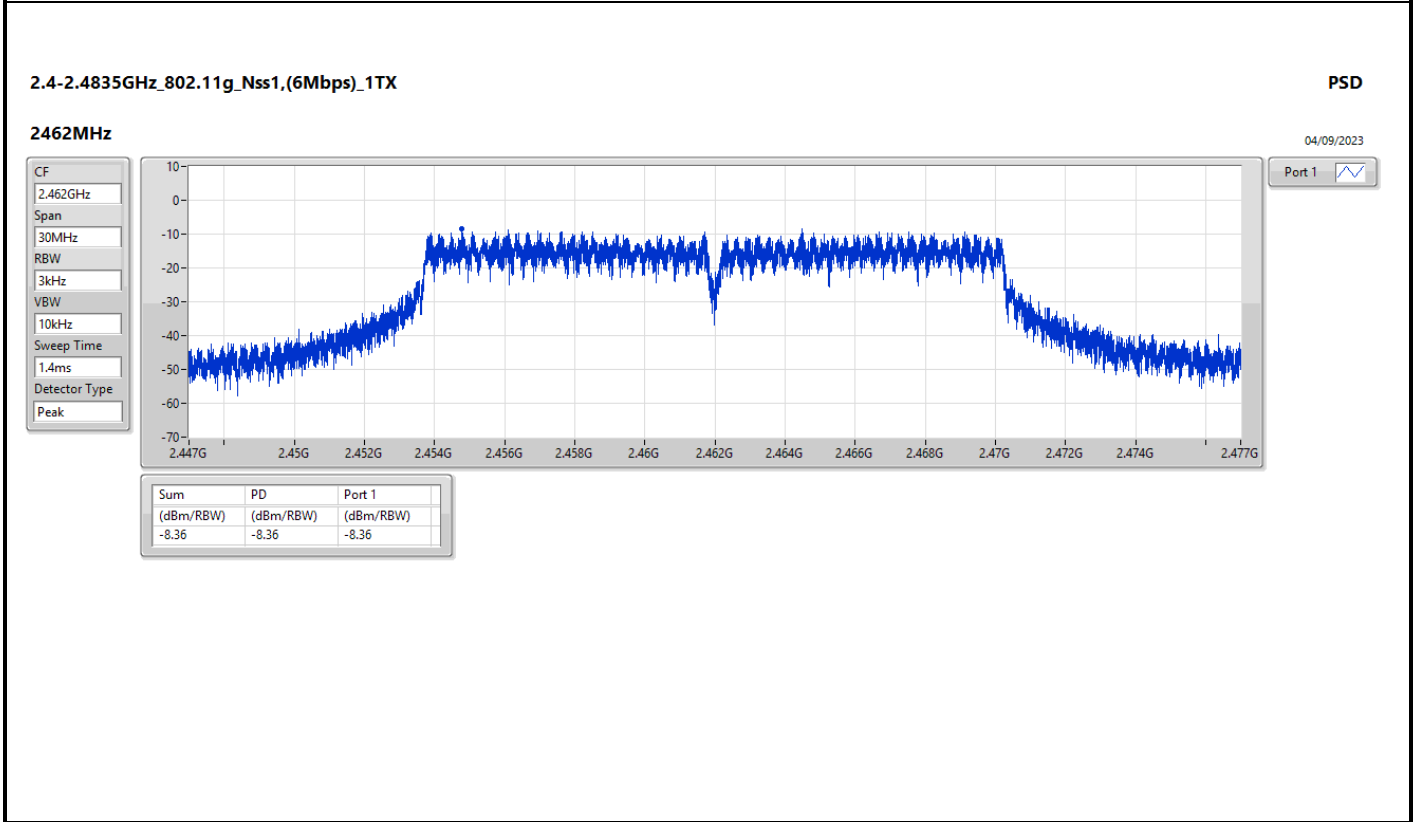
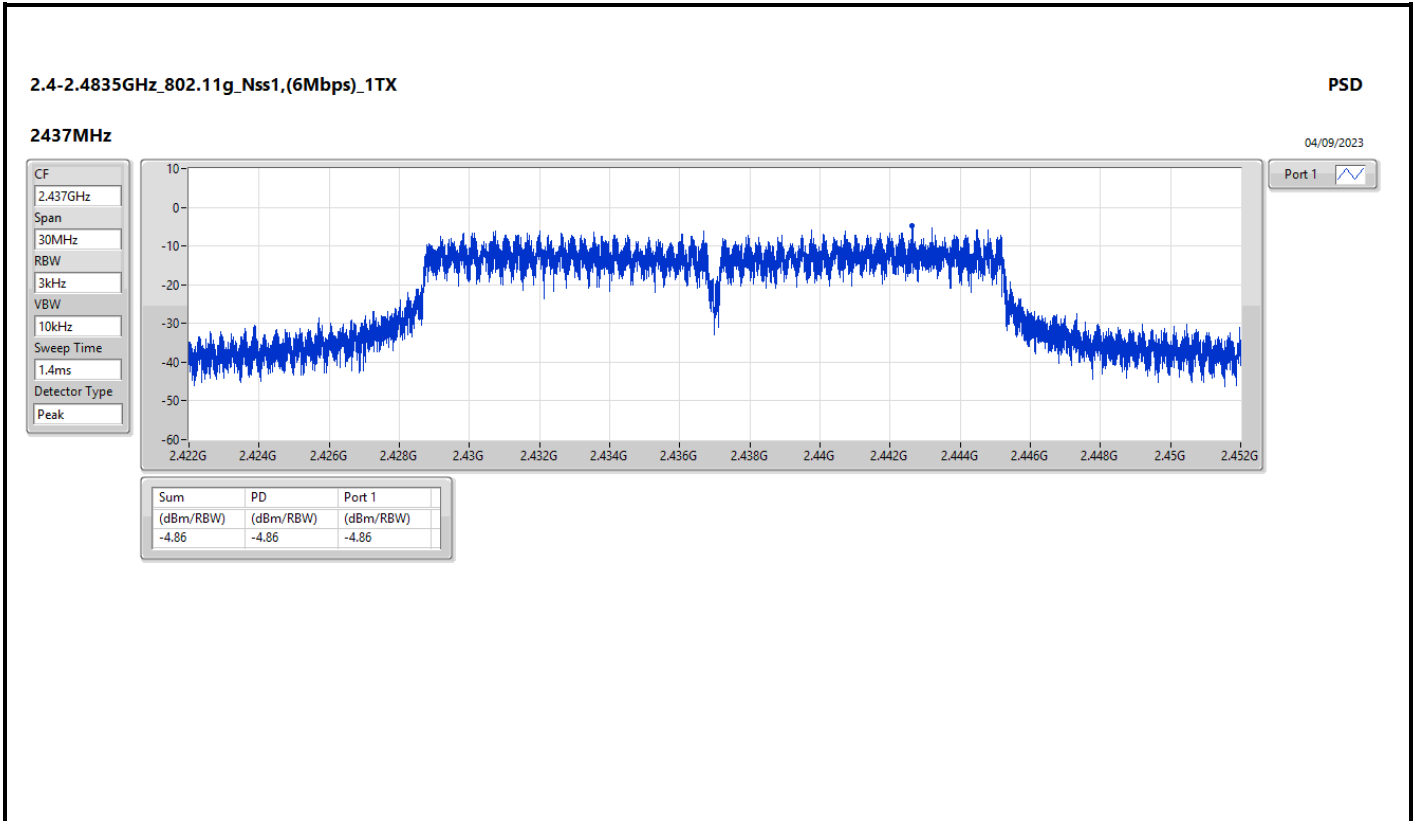

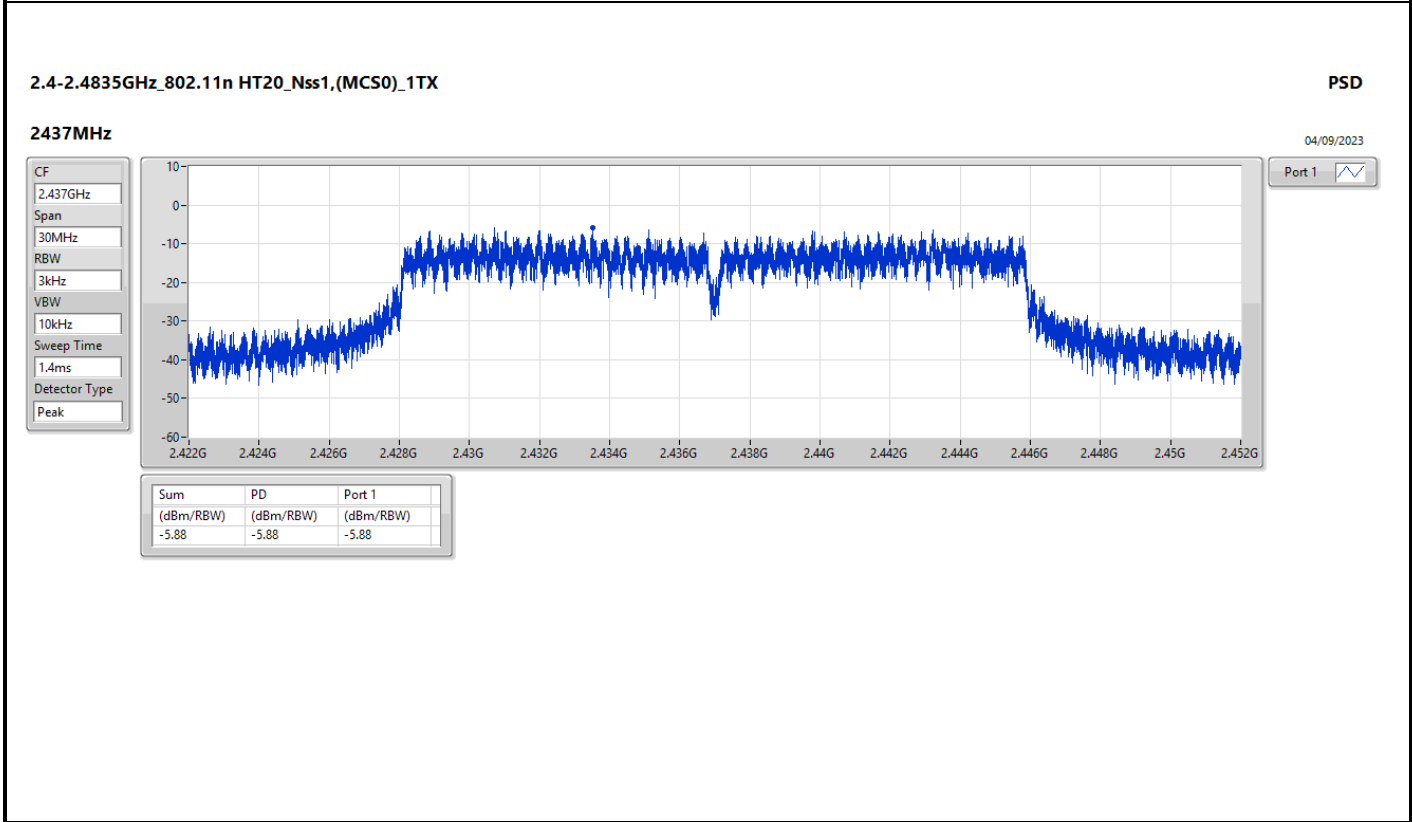
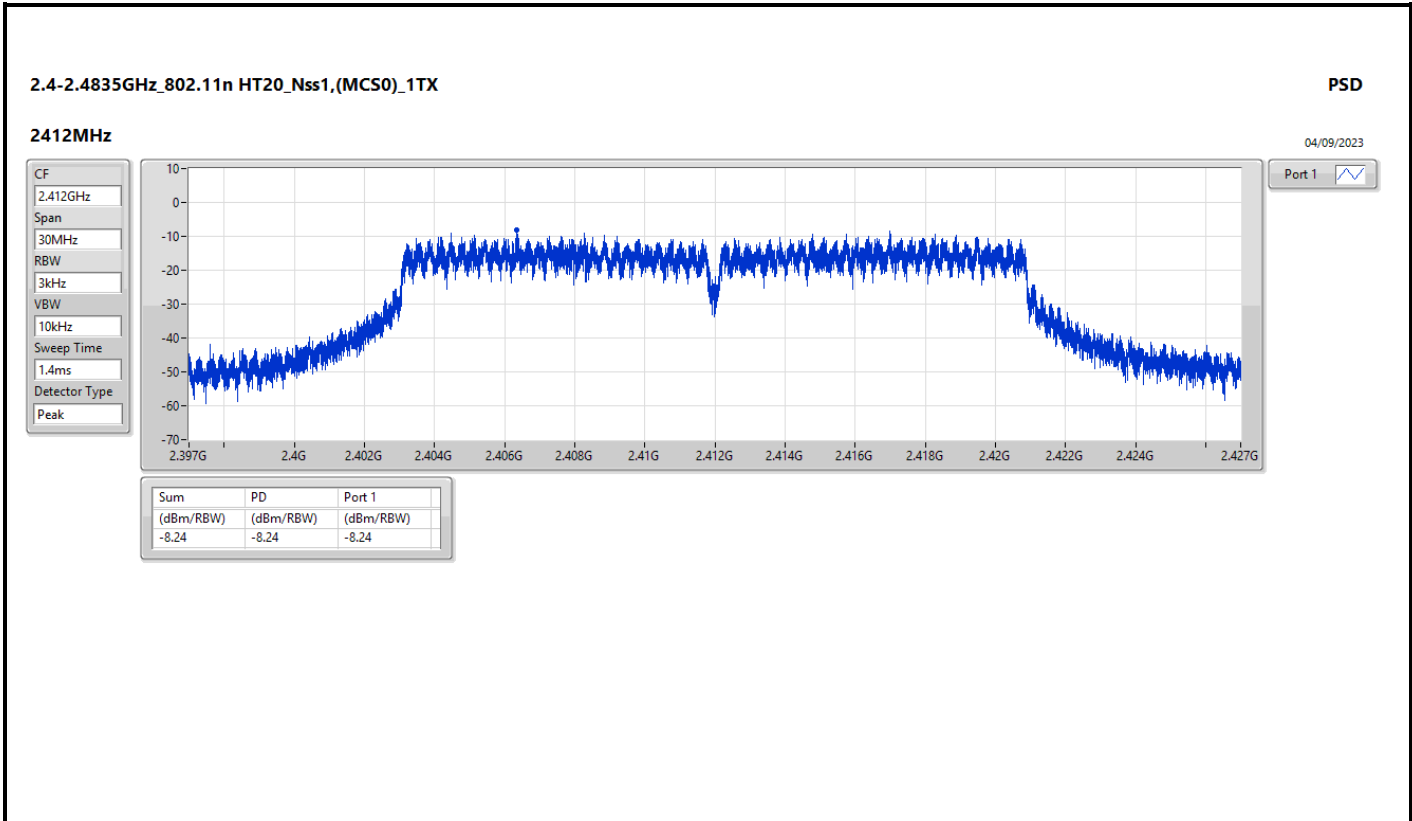



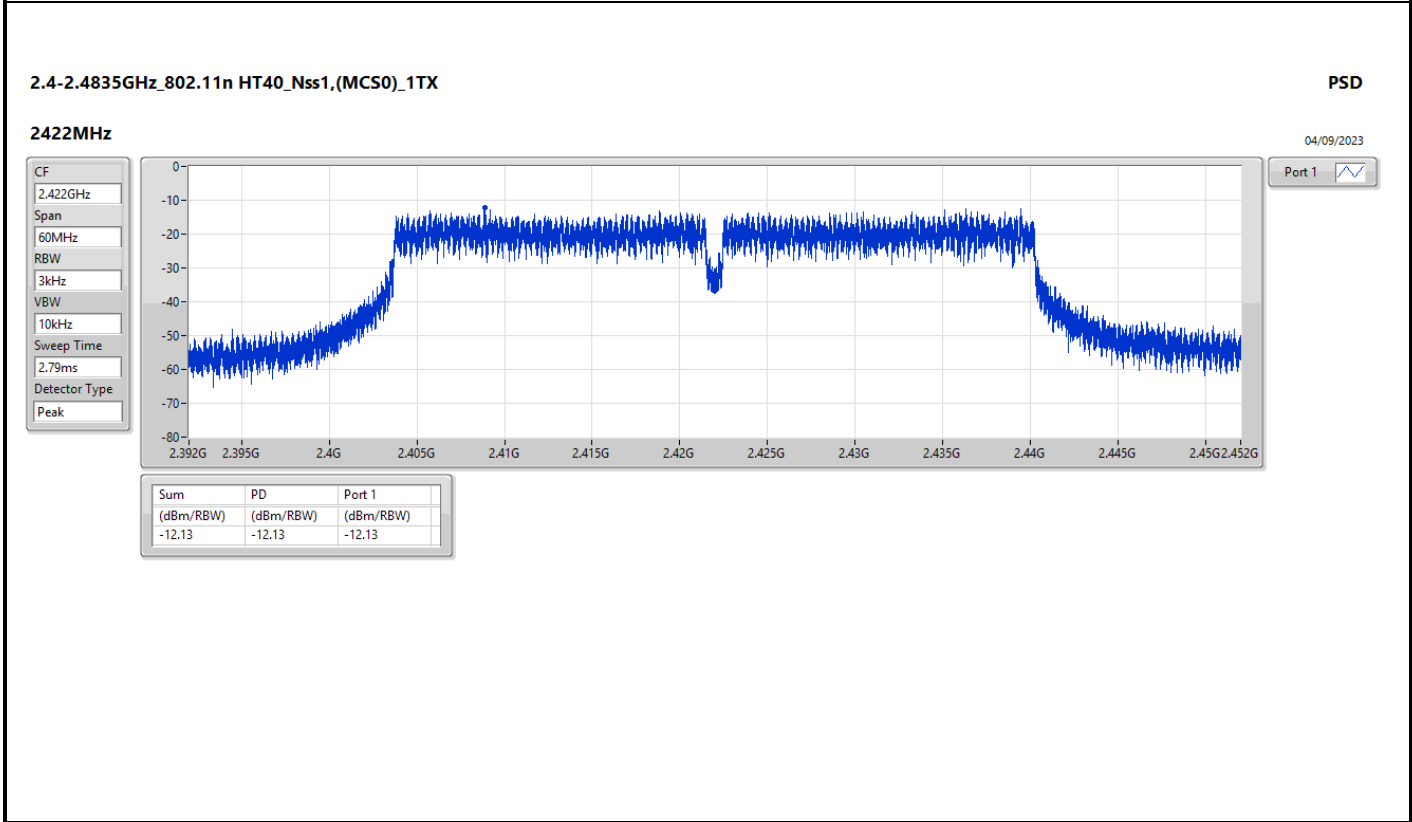
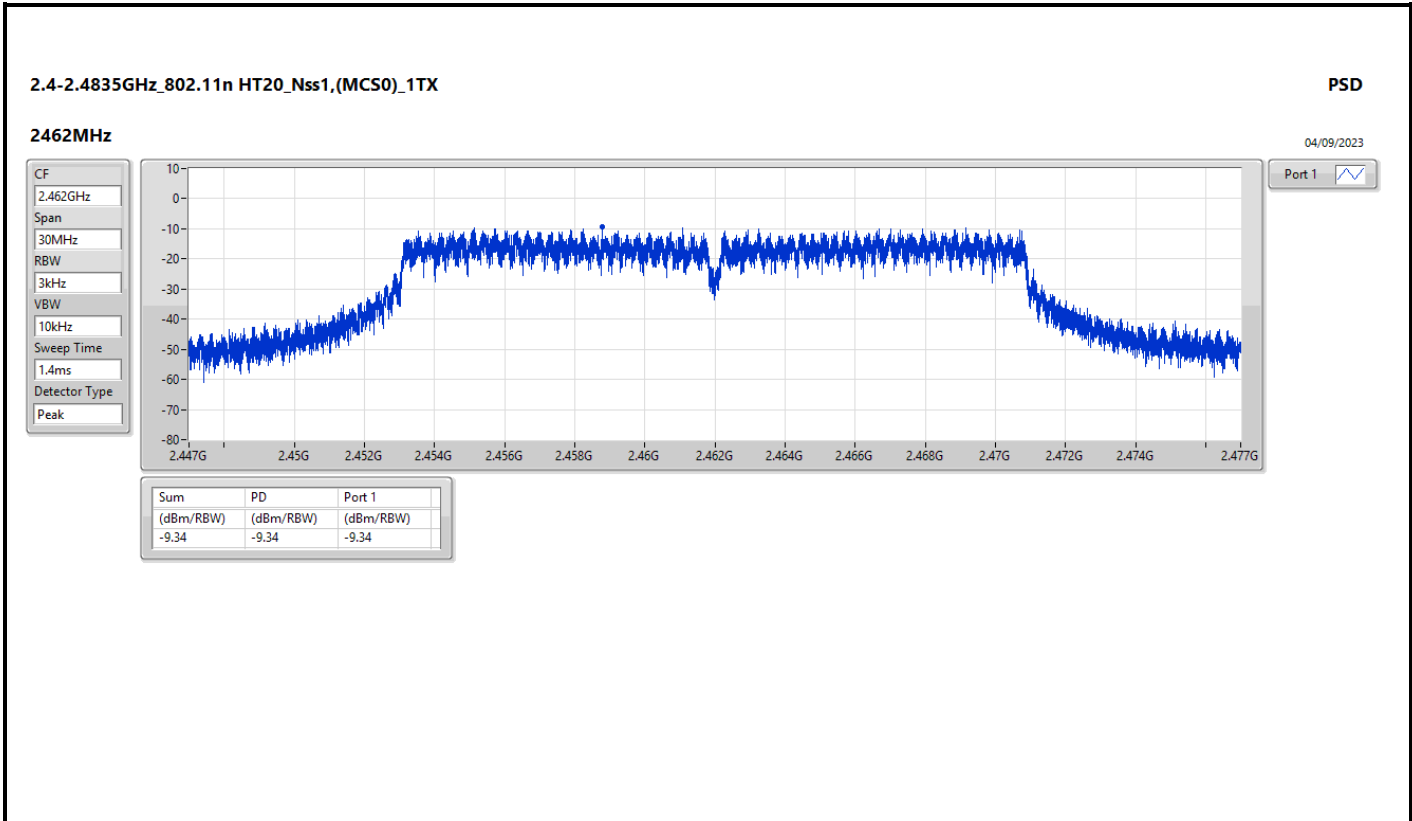

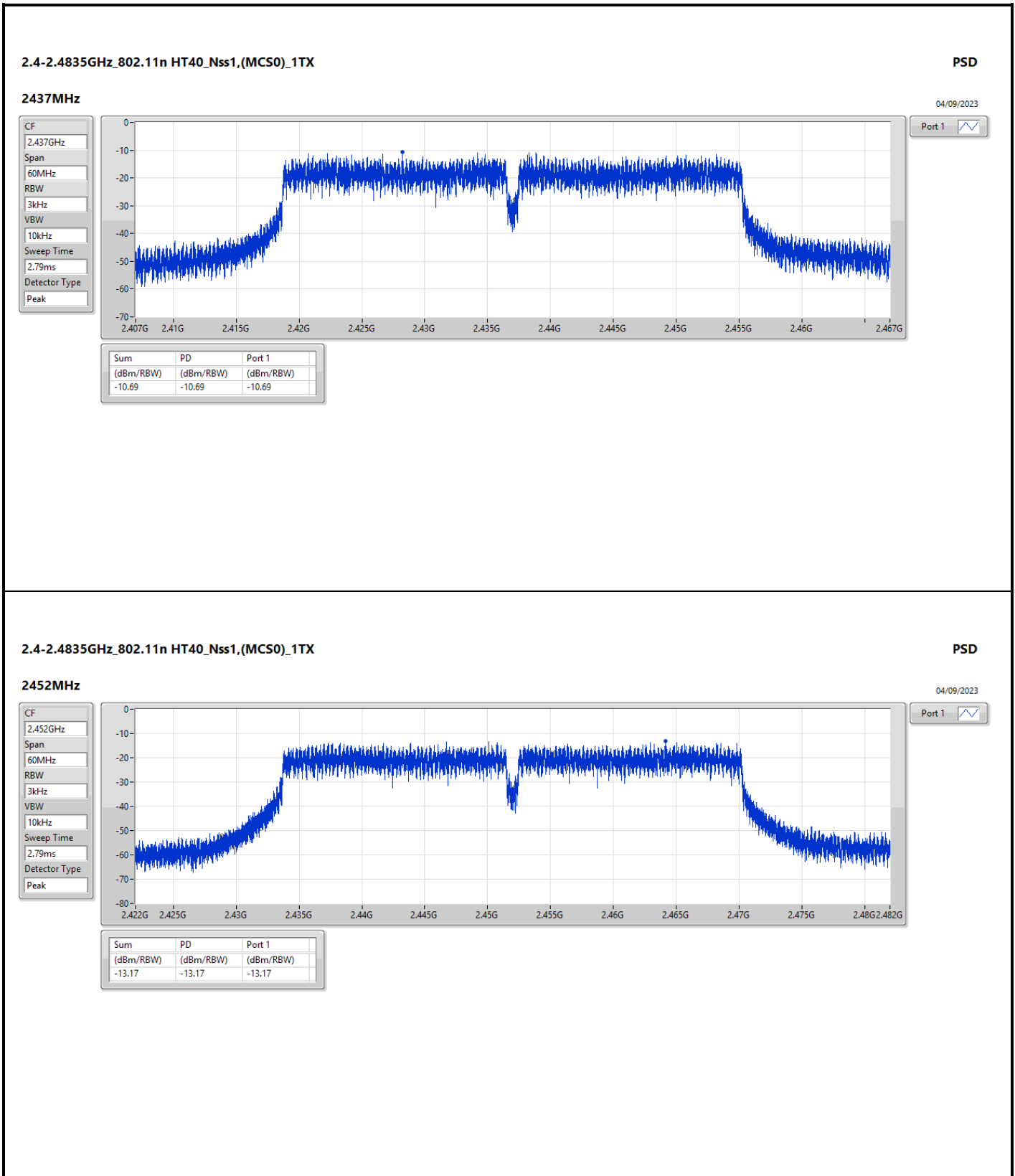



Summary

| Mode                         | Result | Ref (Hz) | Ref (dBm) | Limit (dBm) | Freq (Hz) | Level (dBm) | Freq (Hz) | Level (dBm) | Freq (Hz) | Level (dBm) | Freq (Hz) | Level (dBm) | Freq (Hz) | Level (dBm) | Port |
|------------------------------|--------|----------|-----------|-------------|-----------|-------------|-----------|-------------|-----------|-------------|-----------|-------------|-----------|-------------|------|
| 2.4-2.4835GHz                | -      | -        | -         | -           | -         | -           | -         | -           | -         | -           | -         | -           | -         | -           | -    |
| 802.11b_Nss1,(1Mbps)_1TX     | Pass   | 2.41236G | 13.06     | -16.94      | 1.73906G  | -54.00      | 2.398G    | -17.99      | 2.4G      | -22.86      | 2.50046G  | -51.10      | 21.58919G | -47.79      | 1    |
| 802.11g_Nss1,(6Mbps)_1TX     | Pass   | 2.43073G | 9.94      | -20.06      | 2.16312G  | -53.49      | 2.39888G  | -21.26      | 2.4G      | -20.89      | 2.51206G  | -50.33      | 21.51614G | -48.37      | 1    |
| 802.11n HT20_Nss1,(MCS0)_1TX | Pass   | 2.44192G | 9.94      | -20.06      | 33.5M     | -52.74      | 2.39856G  | -24.89      | 2.4G      | -26.70      | 2.51486G  | -51.13      | 21.52176G | -47.35      | 1    |
| 802.11n HT40_Nss1,(MCS0)_1TX | Pass   | 2.42071G | 4.20      | -25.80      | 2.17802G  | -54.08      | 2.39984G  | -28.34      | 2.4G      | -31.54      | 2.50078G  | -46.72      | 21.52234G | -47.37      | 1    |



Result

| Mode                         | Result | Ref (Hz) | Ref (dBm) | Limit (dBm) | Freq (Hz) | Level (dBm) | Freq (Hz) | Level (dBm) | Freq (Hz) | Level (dBm) | Freq (Hz) | Level (dBm) | Freq (Hz) | Level (dBm) | Port |
|------------------------------|--------|----------|-----------|-------------|-----------|-------------|-----------|-------------|-----------|-------------|-----------|-------------|-----------|-------------|------|
| 802.11b_Nss1.(1Mbps)_1TX     | -      | -        | -         | -           | -         | -           | -         | -           | -         | -           | -         | -           | -         | -           | -    |
| 2412MHz                      | Pass   | 2.41236G | 13.06     | -16.94      | 1.73906G  | -54.00      | 2.398G    | -17.99      | 2.4G      | -22.86      | 2.50046G  | -51.10      | 21.58919G | -47.79      | 1    |
| 2437MHz                      | Pass   | 2.41236G | 13.06     | -16.94      | 2.17943G  | -53.77      | 2.4G      | -49.86      | 2.4G      | -51.71      | 2.50646G  | -50.67      | 21.52738G | -47.46      | 1    |
| 2462MHz                      | Pass   | 2.41236G | 13.06     | -16.94      | 2.30991G  | -52.62      | 2.39656G  | -51.66      | 2.4G      | -54.39      | 2.50294G  | -50.53      | 21.63695G | -46.63      | 1    |
| 802.11g_Nss1.(6Mbps)_1TX     | -      | -        | -         | -           | -         | -           | -         | -           | -         | -           | -         | -           | -         | -           | -    |
| 2412MHz                      | Pass   | 2.43073G | 9.94      | -20.06      | 2.16312G  | -53.49      | 2.39888G  | -21.26      | 2.4G      | -20.89      | 2.51206G  | -50.33      | 21.51614G | -48.37      | 1    |
| 2437MHz                      | Pass   | 2.43073G | 9.94      | -20.06      | 2.18991G  | -53.24      | 2.39976G  | -43.88      | 2.4G      | -48.03      | 2.5179G   | -50.78      | 21.96567G | -47.26      | 1    |
| 2462MHz                      | Pass   | 2.43073G | 9.94      | -20.06      | 2.18292G  | -52.74      | 2.39184G  | -51.23      | 2.4G      | -54.66      | 2.50014G  | -50.33      | 21.44028G | -47.44      | 1    |
| 802.11n HT20_Nss1.(MCS0)_1TX | -      | -        | -         | -           | -         | -           | -         | -           | -         | -           | -         | -           | -         | -           | -    |
| 2412MHz                      | Pass   | 2.44192G | 9.94      | -20.06      | 33.5M     | -52.74      | 2.39856G  | -24.89      | 2.4G      | -26.70      | 2.51486G  | -51.13      | 21.52176G | -47.35      | 1    |
| 2437MHz                      | Pass   | 2.44192G | 9.94      | -20.06      | 39.32M    | -54.23      | 2.39992G  | -45.76      | 2.4G      | -45.95      | 2.50014G  | -49.62      | 21.5049G  | -46.51      | 1    |
| 2462MHz                      | Pass   | 2.44192G | 9.94      | -20.06      | 2.18176G  | -53.60      | 2.39416G  | -51.48      | 2.4G      | -54.82      | 2.51646G  | -50.85      | 21.59481G | -48.03      | 1    |
| 802.11n HT40_Nss1.(MCS0)_1TX | -      | -        | -         | -           | -         | -           | -         | -           | -         | -           | -         | -           | -         | -           | -    |
| 2422MHz                      | Pass   | 2.42071G | 4.20      | -25.80      | 2.15856G  | -53.82      | 2.39968G  | -28.44      | 2.4G      | -28.87      | 2.54062G  | -53.27      | 21.54758G | -47.11      | 1    |
| 2437MHz                      | Pass   | 2.42071G | 4.20      | -25.80      | 2.17802G  | -54.08      | 2.39984G  | -28.34      | 2.4G      | -31.54      | 2.50078G  | -46.72      | 21.52234G | -47.37      | 1    |
| 2452MHz                      | Pass   | 2.42071G | 4.20      | -25.80      | 1.74292G  | -53.27      | 2.39392G  | -49.71      | 2.4G      | -49.94      | 2.5003G   | -44.29      | 21.57282G | -46.97      | 1    |

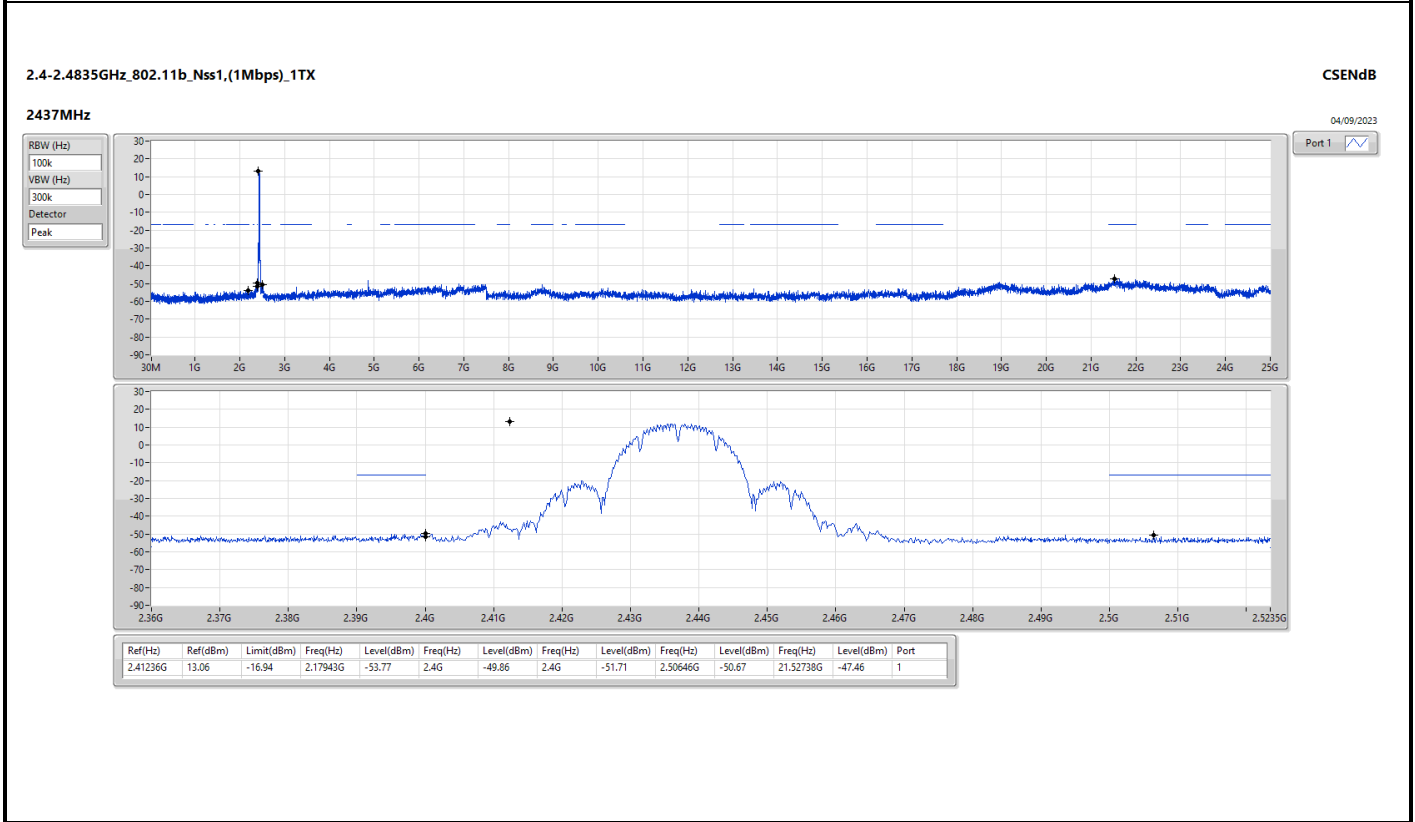
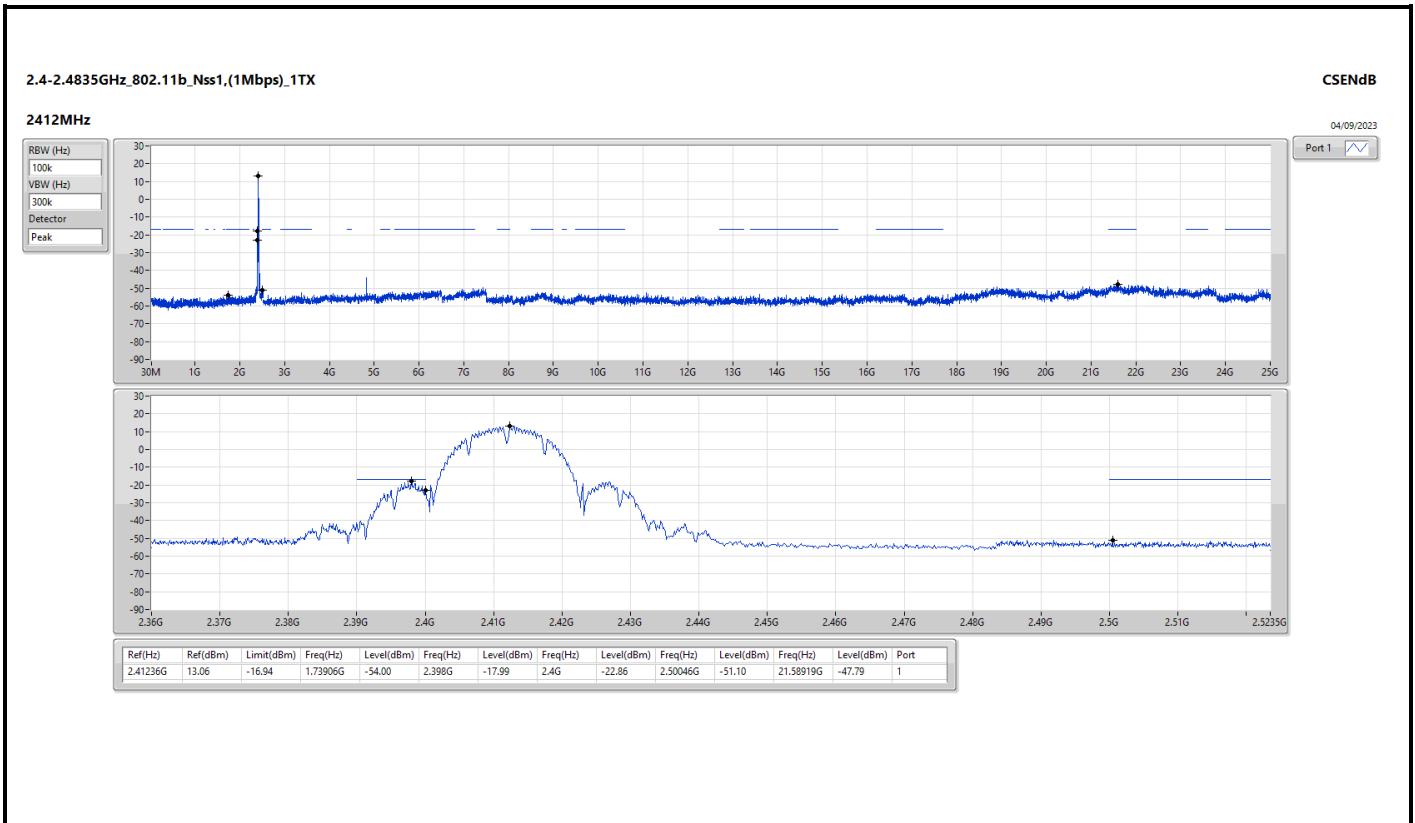

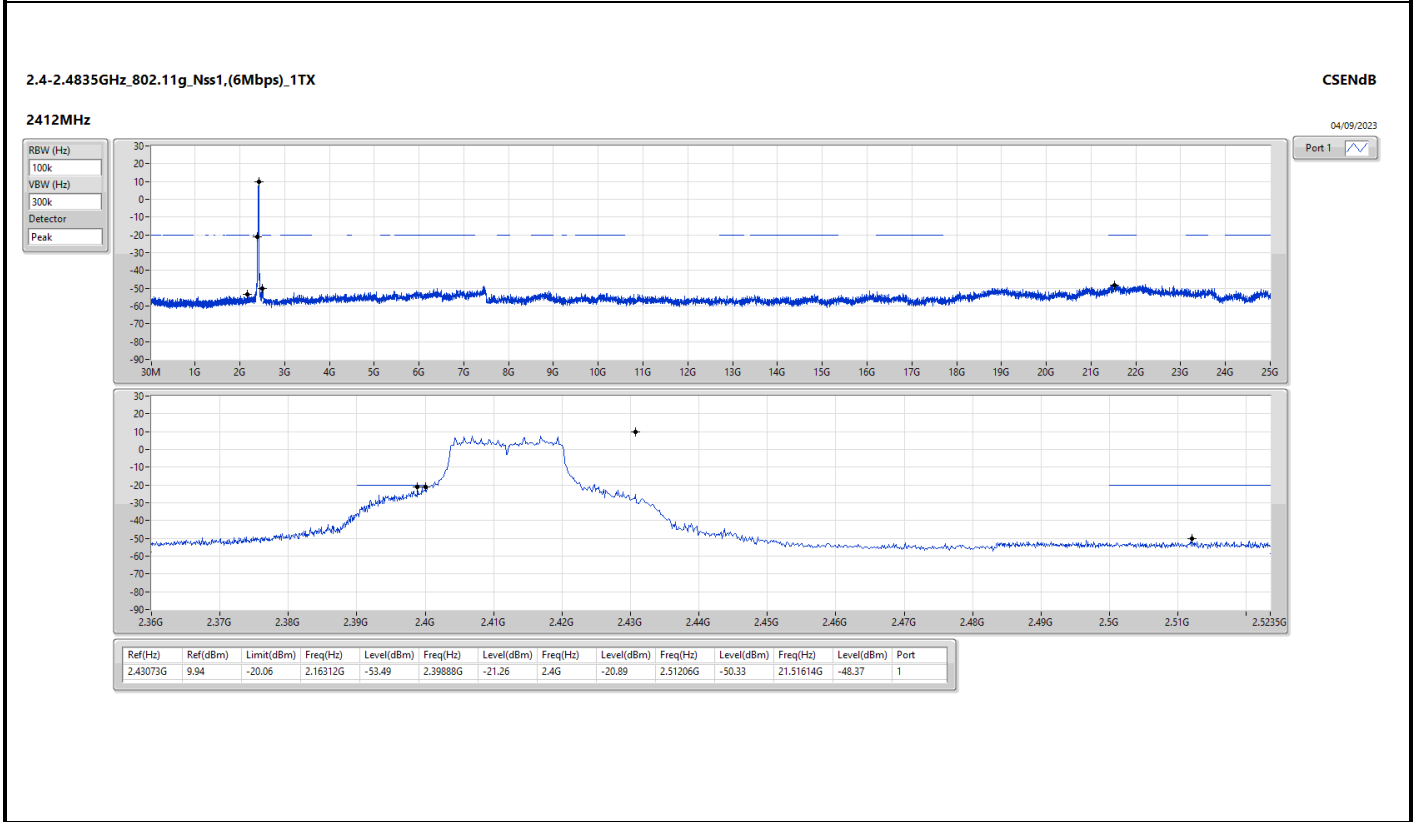
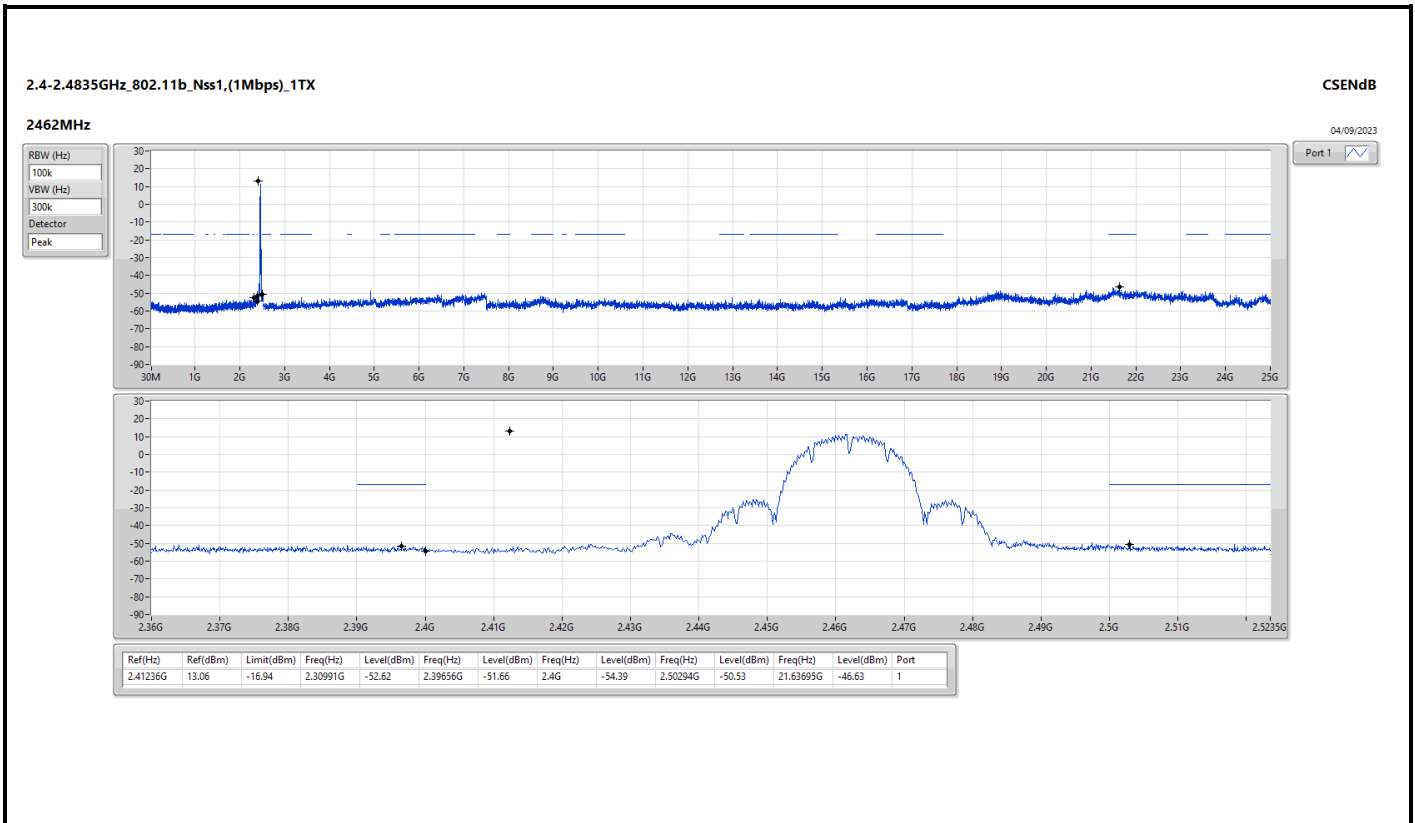

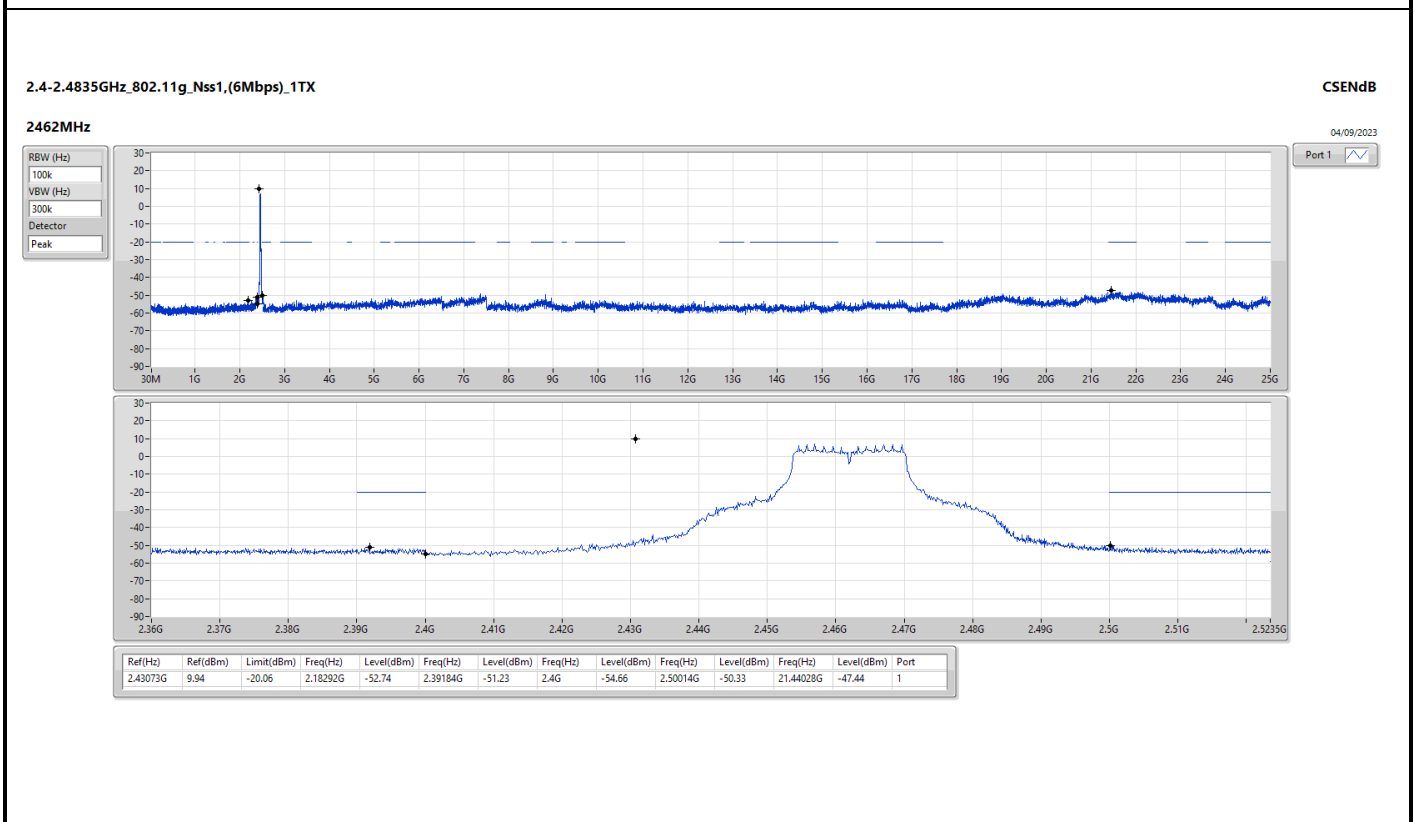
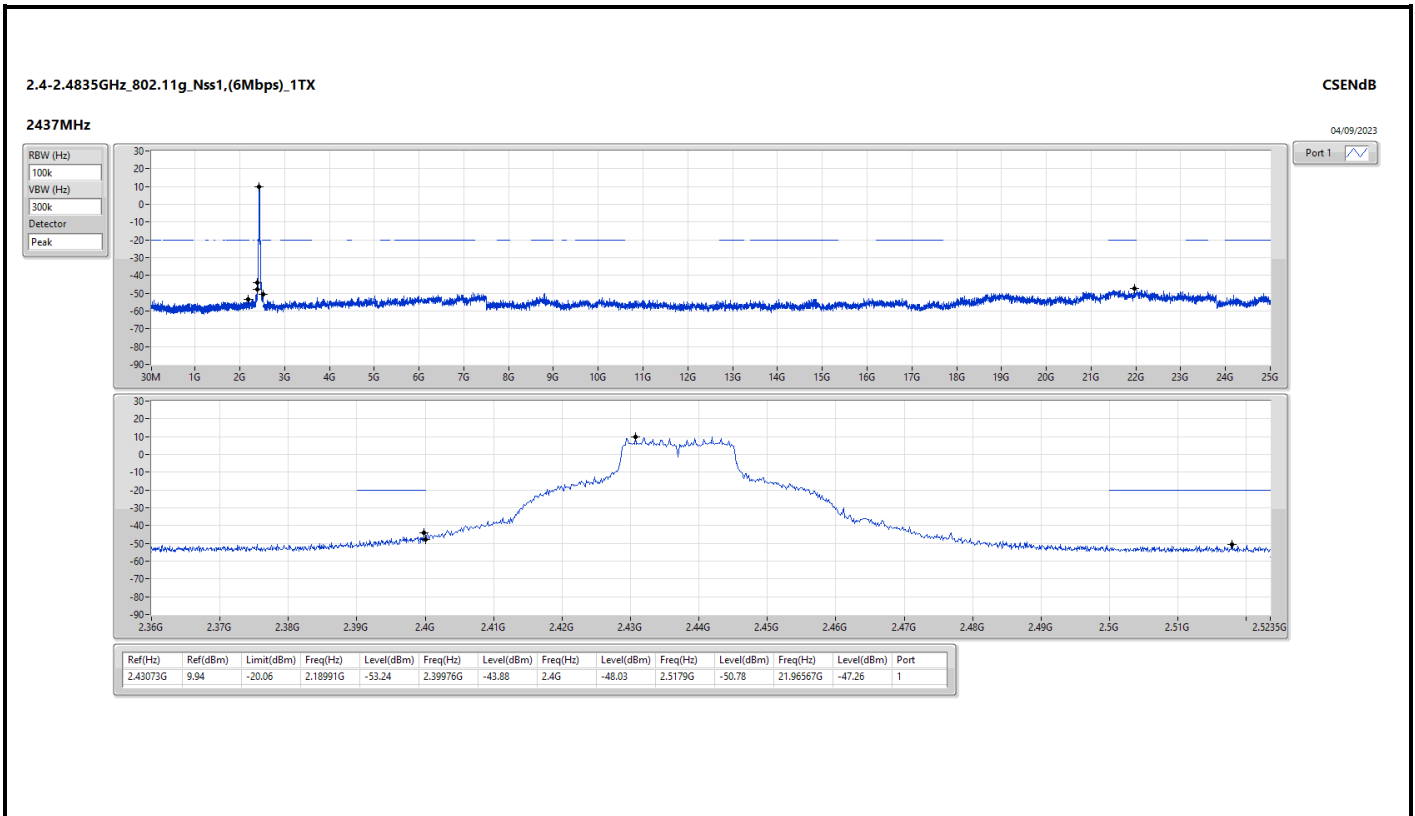

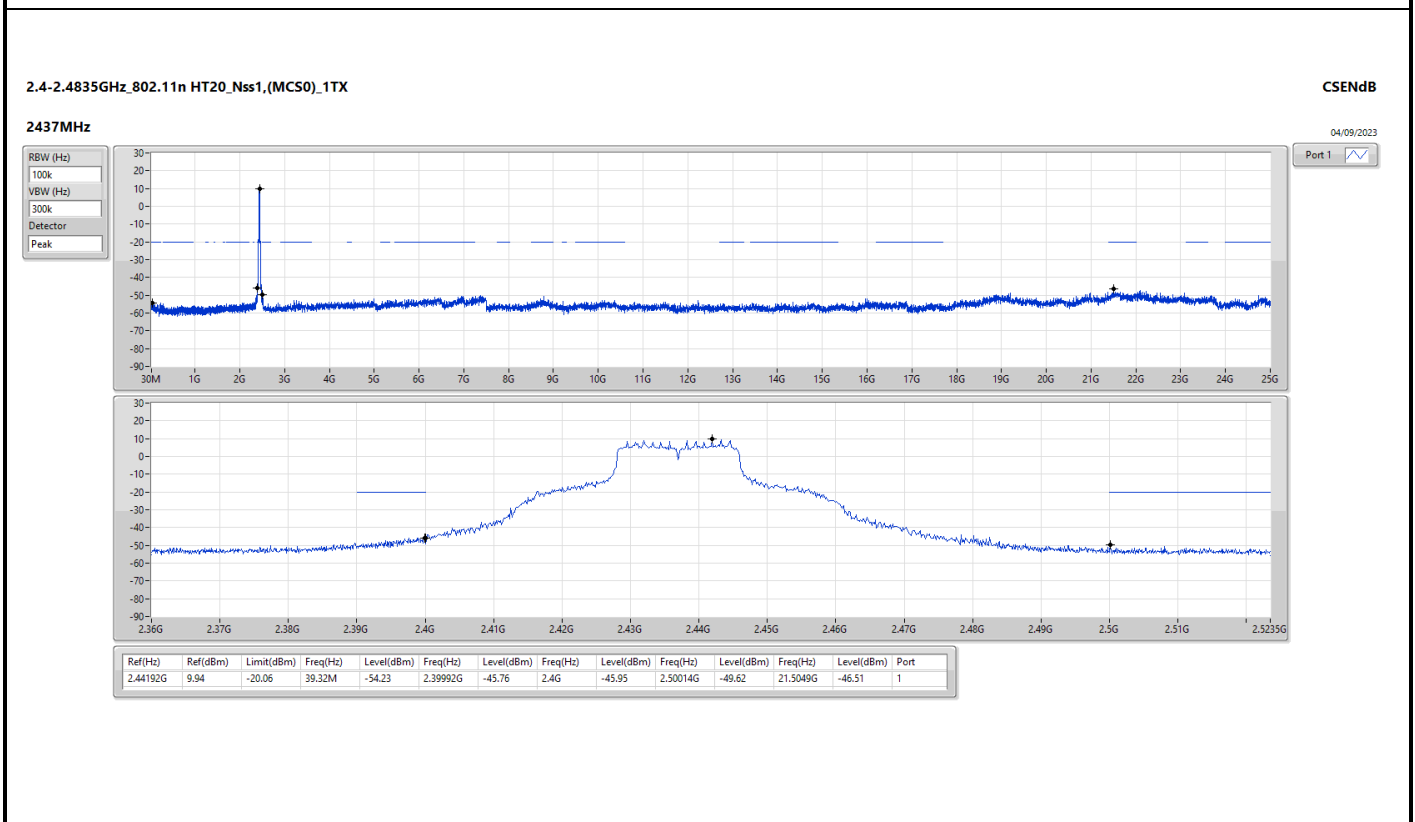
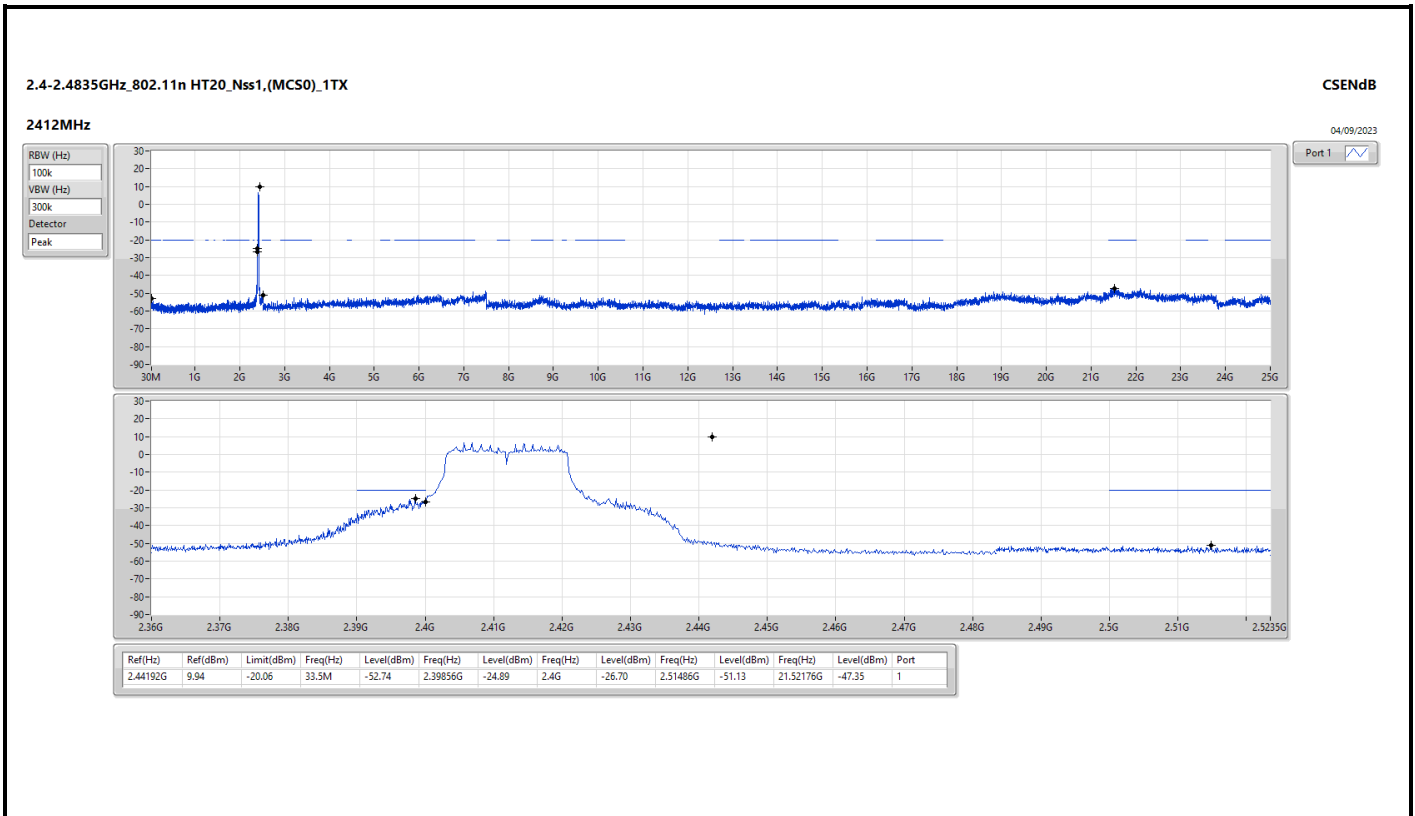



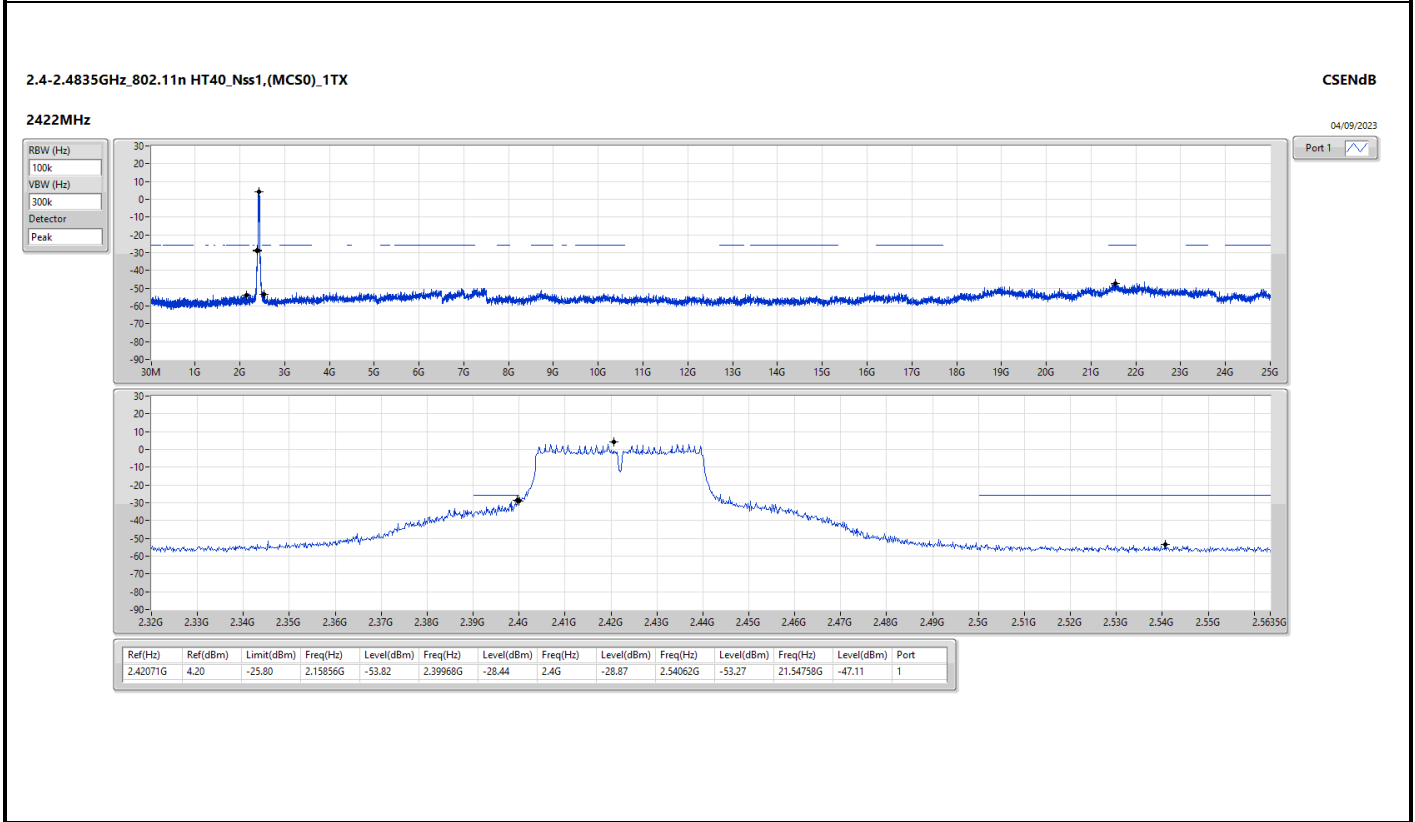
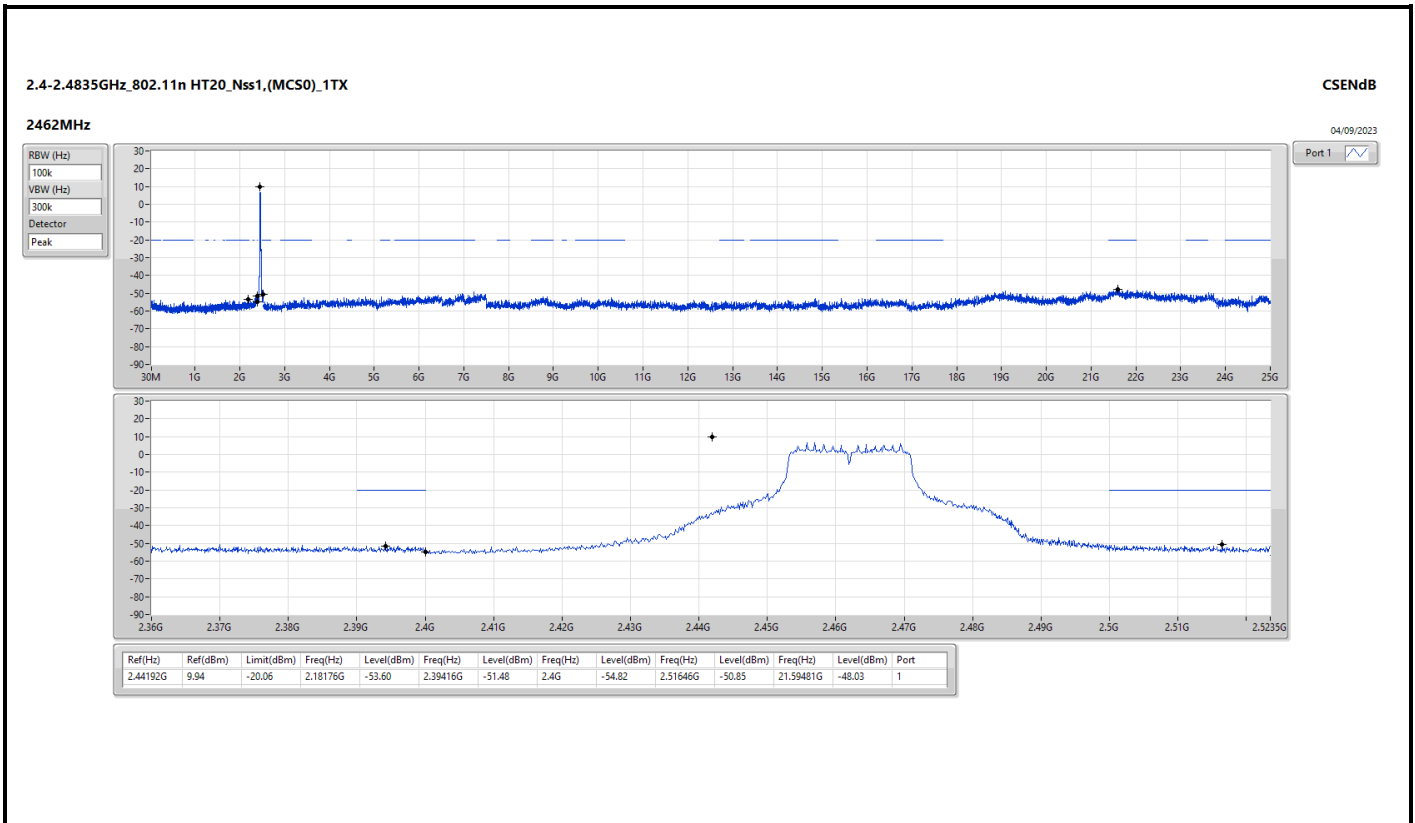

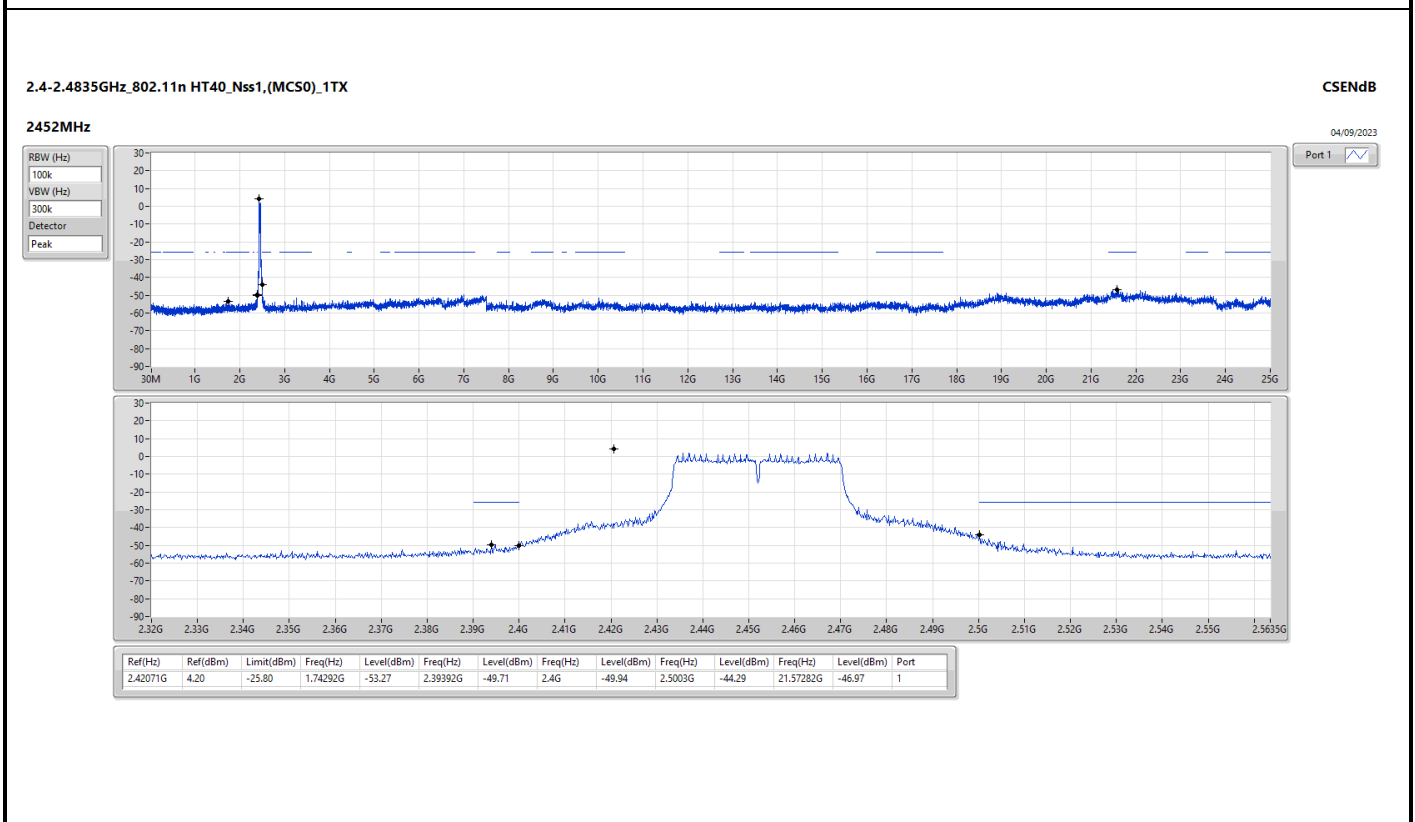
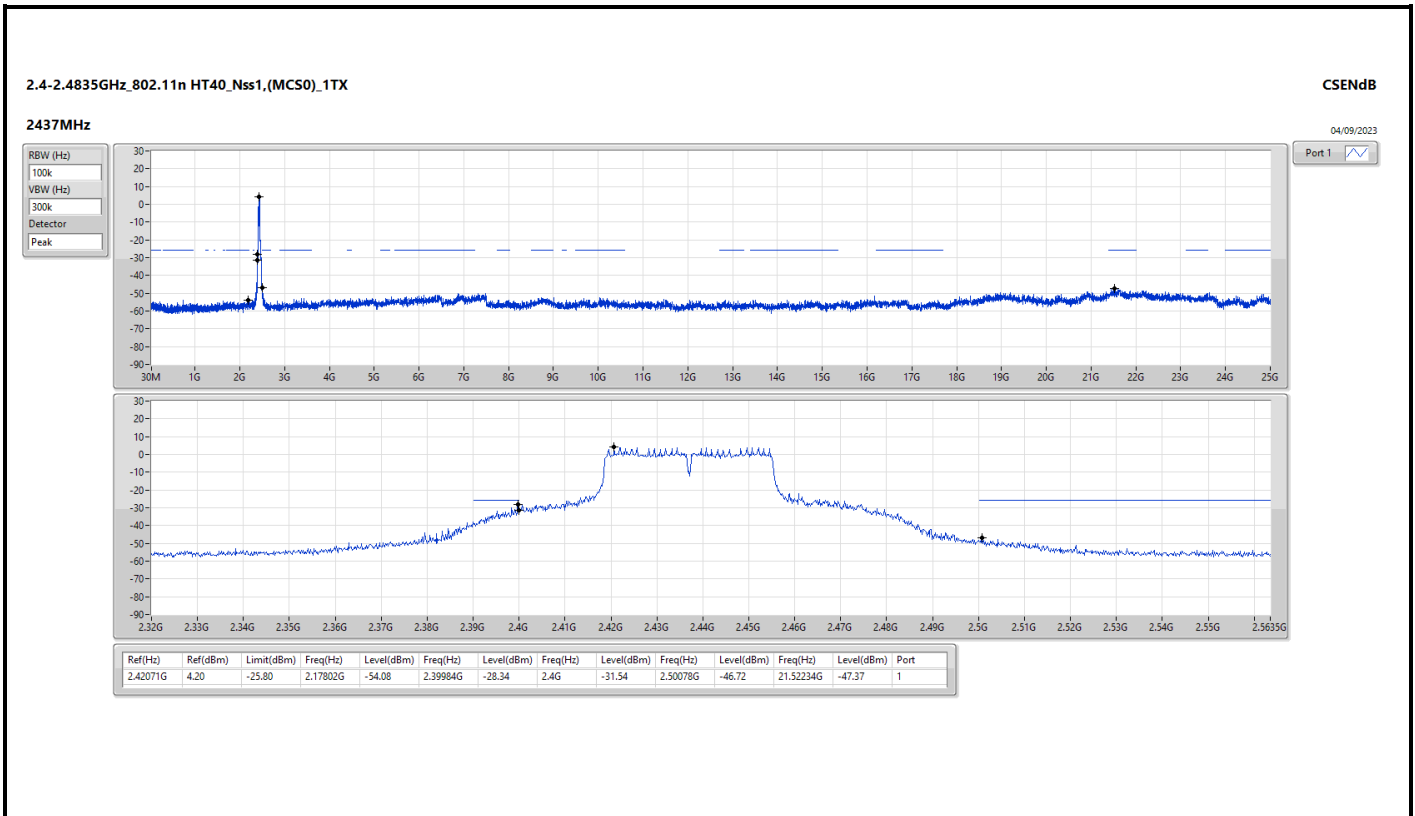



**Summary**

| Mode   | Result | Type | Freq (Hz) | Level (dBuV/m) | Limit (dBuV/m) | Margin (dB) | Condition |
|--------|--------|------|-----------|----------------|----------------|-------------|-----------|
| Mode 3 | Pass   | QP   | 31.94M    | 39.46          | 40.00          | -0.54       | Vertical  |

Mode 3

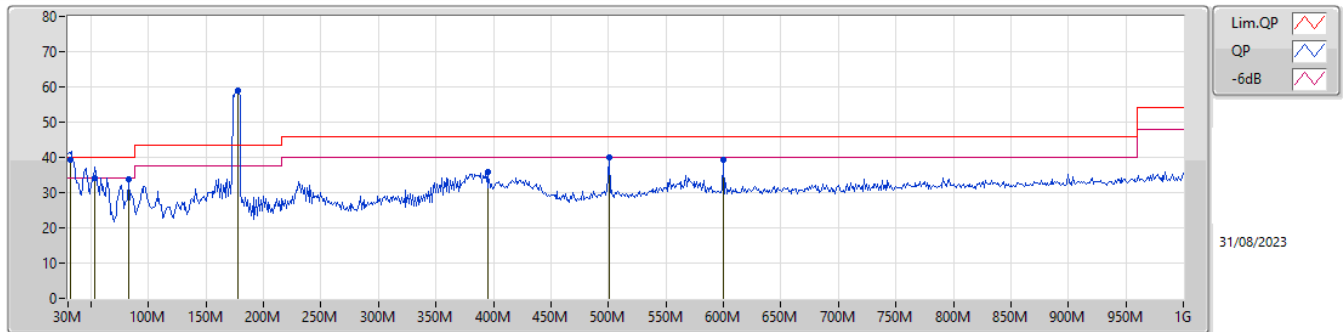

| Type | Freq (Hz) | Level (dBuV/m) | Limit (dBuV/m) | Margin (dB) | Factor (dB/m) | Dist (m) | Condition | Azimuth (°) | Height (m) | Comment | Raw (dBuV/m) | AF (dB/m) | CL (dB) | PA (dB) |
|------|-----------|----------------|----------------|-------------|---------------|----------|-----------|-------------|------------|---------|--------------|-----------|---------|---------|
| QP   | 31.94M    | 39.46          | 40.00          | -0.54       | -3.75         | 3        | Vertical  | 0           | 3.00       | "Worst" | 43.21        | 24.00     | 0.76    | 28.51   |
| QP   | 53.28M    | 34.04          | 40.00          | -5.96       | -14.46        | 3        | Vertical  | 12          | 1.25       | -       | 48.50        | 13.19     | 0.96    | 28.61   |
| PK   | 82.38M    | 33.85          | 40.00          | -6.15       | -13.98        | 3        | Vertical  | 65          | 1.00       | -       | 47.83        | 13.44     | 1.18    | 28.60   |
| PK   | 177.44M   | 59.00          | -              | -           | -11.33        | 3        | Vertical  | 3           | 1.50       | -       | 70.33        | 15.14     | 1.72    | 28.19   |
| PK   | 394.72M   | 35.76          | 46.00          | -10.24      | -4.57         | 3        | Vertical  | 222         | 1.00       | -       | 40.33        | 21.48     | 2.59    | 28.64   |
| PK   | 500.45M   | 40.08          | 46.00          | -5.92       | -3.03         | 3        | Vertical  | 359         | 2.00       | -       | 43.11        | 23.35     | 2.96    | 29.34   |
| PK   | 600.36M   | 39.34          | 46.00          | -6.66       | -1.37         | 3        | Vertical  | 69          | 1.25       | -       | 40.71        | 24.76     | 3.21    | 29.34   |

Mode 3

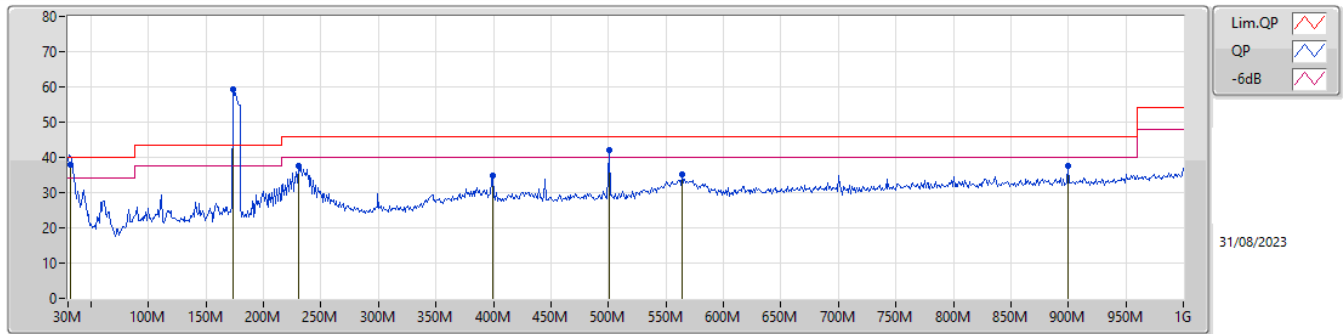

| Type | Freq (Hz) | Level (dBuV/m) | Limit (dBuV/m) | Margin (dB) | Factor (dB/m) | Dist (m) | Condition  | Azimuth (°) | Height (m) | Comment | Raw (dBuV/m) | AF (dB/m) | CL (dB) | PA (dB) |
|------|-----------|----------------|----------------|-------------|---------------|----------|------------|-------------|------------|---------|--------------|-----------|---------|---------|
| QP   | 31.94M    | 37.76          | 40.00          | -2.24       | -3.75         | 3        | Horizontal | 161         | 3.00       | "Worst" | 41.51        | 24.00     | 0.76    | 28.51   |
| PK   | 173.56M   | 59.24          | -              | -           | -11.15        | 3        | Horizontal | 120         | 1.25       | -       | 70.39        | 15.37     | 1.70    | 28.22   |
| PK   | 230.79M   | 37.73          | 46.00          | -8.27       | -9.84         | 3        | Horizontal | 358         | 1.25       | -       | 47.57        | 16.12     | 1.99    | 27.95   |
| PK   | 399.57M   | 34.73          | 46.00          | -11.27      | -4.34         | 3        | Horizontal | 313         | 1.00       | -       | 39.07        | 21.73     | 2.61    | 28.68   |
| PK   | 500.45M   | 42.05          | 46.00          | -3.95       | -3.03         | 3        | Horizontal | 274         | 1.00       | -       | 45.08        | 23.35     | 2.96    | 29.34   |
| PK   | 564.47M   | 35.27          | 46.00          | -10.73      | -1.40         | 3        | Horizontal | 159         | 1.50       | -       | 36.67        | 24.80     | 3.16    | 29.36   |
| PK   | 900.09M   | 37.59          | 46.00          | -8.41       | 1.68          | 3        | Horizontal | 336         | 1.25       | -       | 35.91        | 26.46     | 3.99    | 28.77   |



Summary

| Mode                     | Result | Type | Freq (Hz) | Level (dBuV/m) | Limit (dBuV/m) | Margin (dB) | Dist (m) | Condition  | Azimuth (°) | Height (m) | Comments |
|--------------------------|--------|------|-----------|----------------|----------------|-------------|----------|------------|-------------|------------|----------|
| 2.4-2.4835GHz            | -      | -    | -         | -              | -              | -           | -        | -          | -           | -          | -        |
| 802.11g_Nss1,(6Mbps)_1TX | Pass   | AV   | 2.4835G   | 53.97          | 54.00          | -0.03       | 3        | Horizontal | 348         | 1.02       | -        |

2.4-2.4835GHz\_802.11b\_Nss1,(1Mbps)\_1TX

2412MHz\_TX

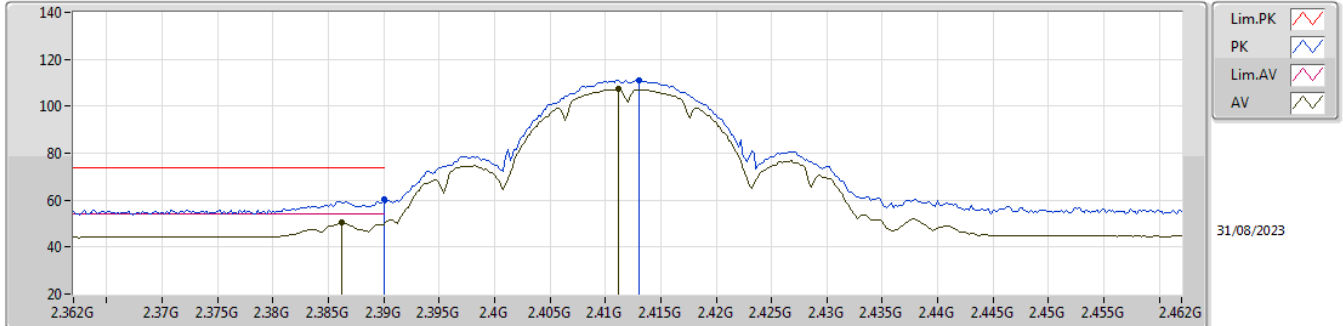

EUT\_Z\_1TX  
Setting 60  
03-E-R-7

| Type | Freq (Hz) | Level (dBuV/m) | Limit (dBuV/m) | Margin (dB) | Raw (dBuV) | Dist (m) | Condition | Azimuth (°) | Height (m) | Comment | AF (dB) | CL (dB) | PA (dB) |
|------|-----------|----------------|----------------|-------------|------------|----------|-----------|-------------|------------|---------|---------|---------|---------|
| PK   | 2.39G     | 60.11          | 74.00          | -13.89      | 27.92      | 3        | Vertical  | 88          | 3.00       | -       | 28.20   | 3.99    | -       |
| AV   | 2.3862G   | 50.36          | 54.00          | -3.64       | 18.17      | 3        | Vertical  | 88          | 3.00       | -       | 28.20   | 3.99    | -       |
| PK   | 2.413G    | 111.16         | Inf            | -Inf        | 78.95      | 3        | Vertical  | 88          | 3.00       | -       | 28.20   | 4.01    | -       |
| AV   | 2.4112G   | 107.25         | Inf            | -Inf        | 75.04      | 3        | Vertical  | 88          | 3.00       | -       | 28.20   | 4.01    | -       |

2.4-2.4835GHz\_802.11b\_Nss1,(1Mbps)\_1TX

2412MHz\_TX

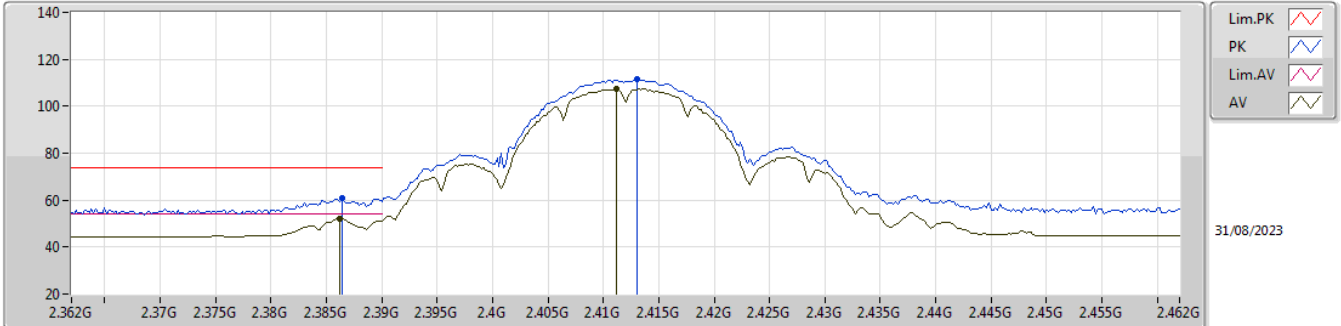

EUT\_Z\_1TX  
Setting 60  
03-E-R-7

| Type | Freq (Hz) | Level (dBuV/m) | Limit (dBuV/m) | Margin (dB) | Raw (dBuV) | Dist (m) | Condition  | Azimuth (°) | Height (m) | Comment | AF (dB) | CL (dB) | PA (dB) |
|------|-----------|----------------|----------------|-------------|------------|----------|------------|-------------|------------|---------|---------|---------|---------|
| PK   | 2.3864G   | 60.72          | 74.00          | -13.28      | 28.53      | 3        | Horizontal | 346         | 1.00       | -       | 28.20   | 3.99    | -       |
| AV   | 2.3862G   | 52.19          | 54.00          | -1.81       | 20.00      | 3        | Horizontal | 346         | 1.00       | -       | 28.20   | 3.99    | -       |
| PK   | 2.413G    | 111.35         | Inf            | -Inf        | 79.14      | 3        | Horizontal | 346         | 1.00       | -       | 28.20   | 4.01    | -       |
| AV   | 2.4112G   | 107.35         | Inf            | -Inf        | 75.14      | 3        | Horizontal | 346         | 1.00       | -       | 28.20   | 4.01    | -       |



2.4-2.4835GHz\_802.11b\_Nss1,(1Mbps)\_1TX

2412MHz\_TX

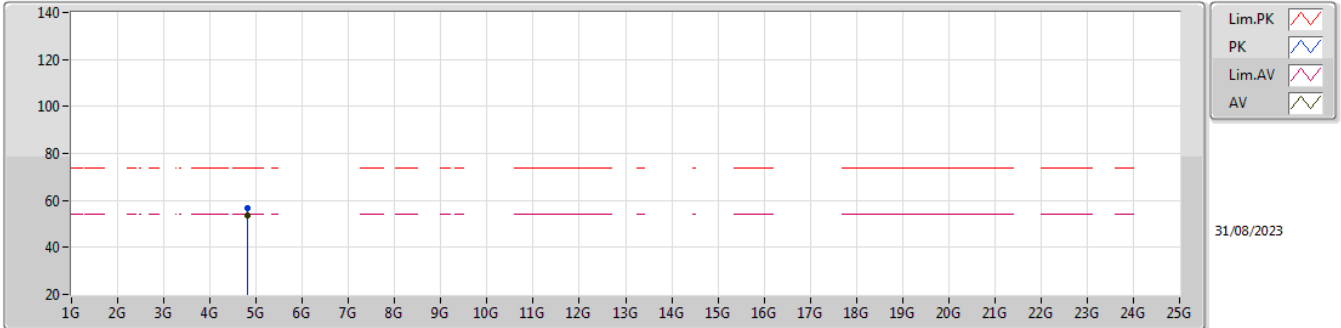

EUT\_Z\_1TX  
Setting 60  
03-E-R-7

| Type | Freq<br>(Hz) | Level<br>(dBuV/m) | Limit<br>(dBuV/m) | Margin<br>(dB) | Raw<br>(dBuV) | Dist<br>(m) | Condition | Azimuth<br>(°) | Height<br>(m) | Comment | AF<br>(dB) | CL<br>(dB) | PA<br>(dB) |
|------|--------------|-------------------|-------------------|----------------|---------------|-------------|-----------|----------------|---------------|---------|------------|------------|------------|
| PK   | 4.824G       | 56.67             | 74.00             | -17.33         | 51.45         | 3           | Vertical  | 70             | 2.90          | -       | 33.40      | 6.51       | 34.69      |
| AV   | 4.824G       | 53.48             | 54.00             | -0.52          | 48.26         | 3           | Vertical  | 70             | 2.90          | -       | 33.40      | 6.51       | 34.69      |

2.4-2.4835GHz\_802.11b\_Nss1,(1Mbps)\_1TX

2412MHz\_TX

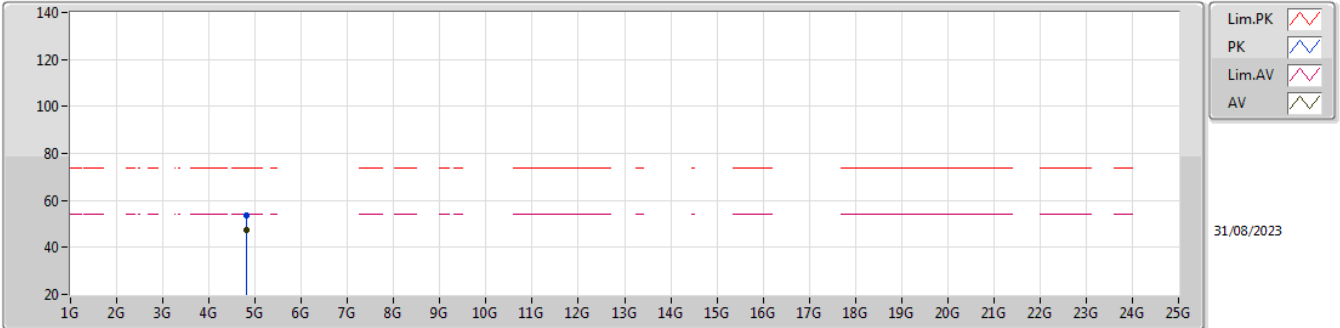

EUT\_Z\_1TX  
Setting 60  
03-E-R-7

| Type | Freq<br>(Hz) | Level<br>(dBuV/m) | Limit<br>(dBuV/m) | Margin<br>(dB) | Raw<br>(dBuV) | Dist<br>(m) | Condition  | Azimuth<br>(°) | Height<br>(m) | Comment | AF<br>(dB) | CL<br>(dB) | PA<br>(dB) |
|------|--------------|-------------------|-------------------|----------------|---------------|-------------|------------|----------------|---------------|---------|------------|------------|------------|
| PK   | 4.8239G      | 53.38             | 74.00             | -20.62         | 48.16         | 3           | Horizontal | 11             | 2.53          | -       | 33.40      | 6.51       | 34.69      |
| AV   | 4.824G       | 47.39             | 54.00             | -6.61          | 42.17         | 3           | Horizontal | 11             | 2.53          | -       | 33.40      | 6.51       | 34.69      |

2.4-2.4835GHz\_802.11b\_Nss1,(1Mbps)\_1TX

2437MHz\_TX

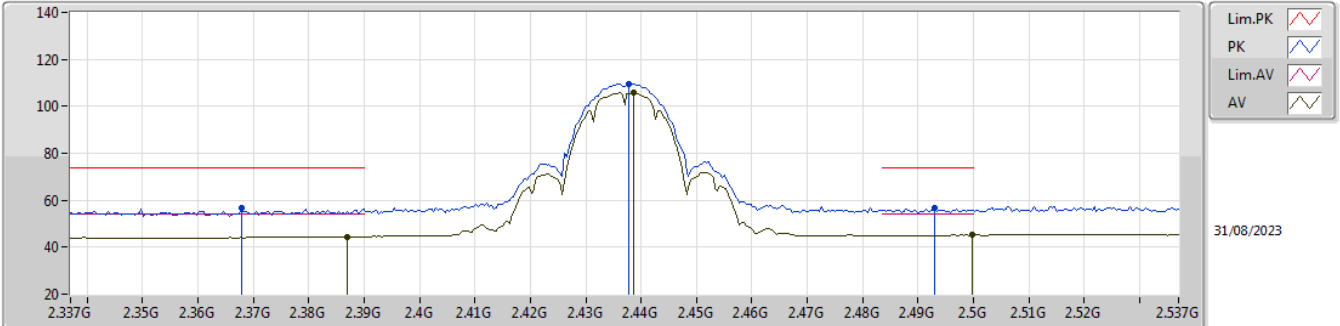

EUT\_Z\_1TX  
Setting 55  
03-E-R-7

| Type | Freq (Hz) | Level (dBuV/m) | Limit (dBuV/m) | Margin (dB) | Raw (dBuV) | Dist (m) | Condition | Azimuth (°) | Height (m) | Comment | AF (dB) | CL (dB) | PA (dB) |
|------|-----------|----------------|----------------|-------------|------------|----------|-----------|-------------|------------|---------|---------|---------|---------|
| PK   | 2.3678G   | 56.71          | 74.00          | -17.29      | 24.54      | 3        | Vertical  | 104         | 2.61       | -       | 28.20   | 3.97    | -       |
| AV   | 2.387G    | 44.48          | 54.00          | -9.52       | 12.29      | 3        | Vertical  | 104         | 2.61       | -       | 28.20   | 3.99    | -       |
| PK   | 2.4378G   | 109.70         | Inf            | -Inf        | 77.46      | 3        | Vertical  | 104         | 2.61       | -       | 28.20   | 4.04    | -       |
| AV   | 2.4386G   | 105.67         | Inf            | -Inf        | 73.43      | 3        | Vertical  | 104         | 2.61       | -       | 28.20   | 4.04    | -       |
| PK   | 2.493G    | 56.71          | 74.00          | -17.29      | 24.16      | 3        | Vertical  | 104         | 2.61       | -       | 28.46   | 4.09    | -       |
| AV   | 2.4998G   | 45.14          | 54.00          | -8.86       | 12.54      | 3        | Vertical  | 104         | 2.61       | -       | 28.50   | 4.10    | -       |

2.4-2.4835GHz\_802.11b\_Nss1,(1Mbps)\_1TX

2437MHz\_TX

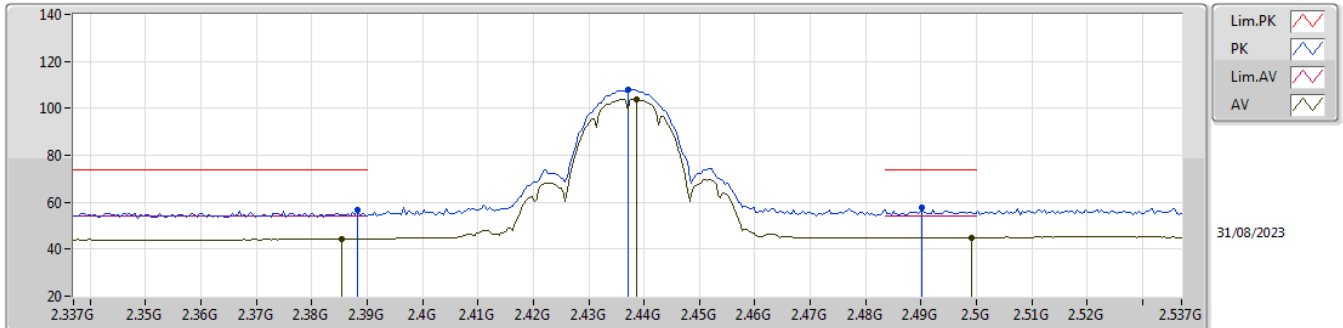

EUT\_Z\_1TX  
Setting 55  
03-E-R-7

| Type | Freq (Hz) | Level (dBuV/m) | Limit (dBuV/m) | Margin (dB) | Raw (dBuV) | Dist (m) | Condition  | Azimuth (°) | Height (m) | Comment | AF (dB) | CL (dB) | PA (dB) |
|------|-----------|----------------|----------------|-------------|------------|----------|------------|-------------|------------|---------|---------|---------|---------|
| PK   | 2.3882G   | 56.69          | 74.00          | -17.31      | 24.50      | 3        | Horizontal | 81          | 1.77       | -       | 28.20   | 3.99    | -       |
| AV   | 2.3854G   | 44.41          | 54.00          | -9.59       | 12.22      | 3        | Horizontal | 81          | 1.77       | -       | 28.20   | 3.99    | -       |
| PK   | 2.437G    | 108.13         | Inf            | -Inf        | 75.89      | 3        | Horizontal | 81          | 1.77       | -       | 28.20   | 4.04    | -       |
| AV   | 2.4386G   | 103.83         | Inf            | -Inf        | 71.59      | 3        | Horizontal | 81          | 1.77       | -       | 28.20   | 4.04    | -       |
| PK   | 2.4902G   | 57.64          | 74.00          | -16.36      | 25.11      | 3        | Horizontal | 81          | 1.77       | -       | 28.44   | 4.09    | -       |
| AV   | 2.499G    | 45.04          | 54.00          | -8.96       | 12.45      | 3        | Horizontal | 81          | 1.77       | -       | 28.49   | 4.10    | -       |

2.4-2.4835GHz\_802.11b\_Nss1,(1Mbps)\_1TX

2437MHz\_TX

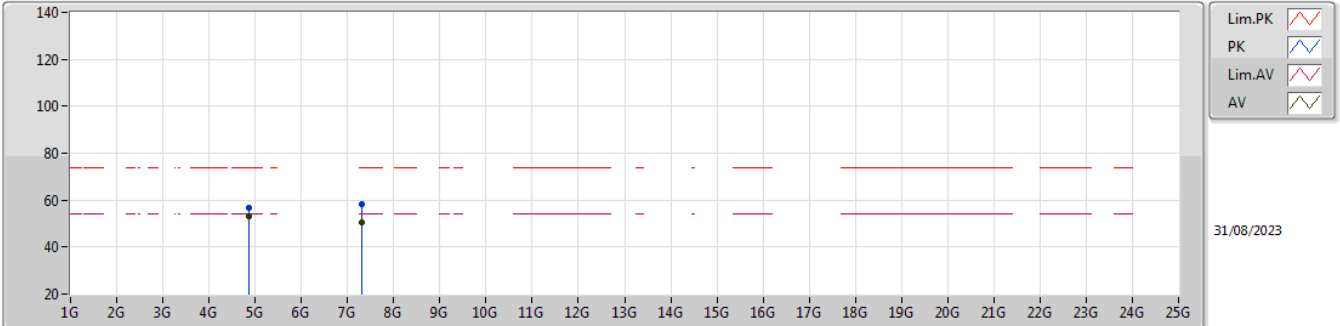

EUT\_Z\_1TX  
Setting 55  
03-E-R-7

| Type | Freq<br>(Hz) | Level<br>(dBuV/m) | Limit<br>(dBuV/m) | Margin<br>(dB) | Raw<br>(dBuV) | Dist<br>(m) | Condition | Azimuth<br>(°) | Height<br>(m) | Comment | AF<br>(dB) | CL<br>(dB) | PA<br>(dB) |
|------|--------------|-------------------|-------------------|----------------|---------------|-------------|-----------|----------------|---------------|---------|------------|------------|------------|
| PK   | 4.8739G      | 56.56             | 74.00             | -17.44         | 51.21         | 3           | Vertical  | 69             | 2.69          | -       | 33.54      | 6.54       | 34.73      |
| AV   | 4.874G       | 53.31             | 54.00             | -0.69          | 47.96         | 3           | Vertical  | 69             | 2.69          | -       | 33.54      | 6.54       | 34.73      |
| PK   | 7.3119G      | 58.15             | 74.00             | -15.85         | 48.01         | 3           | Vertical  | 102            | 1.05          | -       | 36.82      | 8.70       | 35.38      |
| AV   | 7.3102G      | 50.40             | 54.00             | -3.60          | 40.26         | 3           | Vertical  | 102            | 1.05          | -       | 36.82      | 8.70       | 35.38      |

2.4-2.4835GHz\_802.11b\_Nss1,(1Mbps)\_1TX

2437MHz\_TX

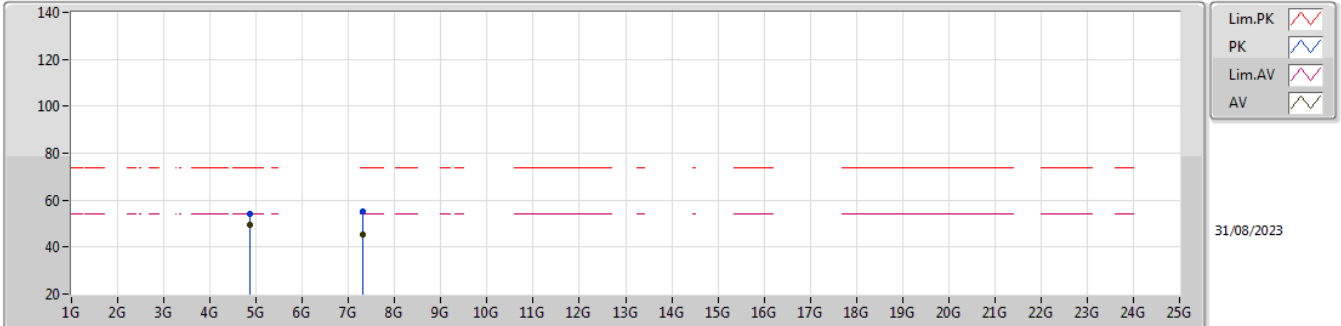

EUT\_Z\_1TX  
Setting 55  
03-E-R-7

| Type | Freq<br>(Hz) | Level<br>(dBuV/m) | Limit<br>(dBuV/m) | Margin<br>(dB) | Raw<br>(dBuV) | Dist<br>(m) | Condition  | Azimuth<br>(°) | Height<br>(m) | Comment | AF<br>(dB) | CL<br>(dB) | PA<br>(dB) |
|------|--------------|-------------------|-------------------|----------------|---------------|-------------|------------|----------------|---------------|---------|------------|------------|------------|
| PK   | 4.874G       | 54.28             | 74.00             | -19.72         | 48.93         | 3           | Horizontal | 282            | 2.91          | -       | 33.54      | 6.54       | 34.73      |
| AV   | 4.874G       | 49.65             | 54.00             | -4.35          | 44.30         | 3           | Horizontal | 282            | 2.91          | -       | 33.54      | 6.54       | 34.73      |
| PK   | 7.3118G      | 55.30             | 74.00             | -18.70         | 45.16         | 3           | Horizontal | 65             | 2.86          | -       | 36.82      | 8.70       | 35.38      |
| AV   | 7.3117G      | 45.57             | 54.00             | -8.43          | 35.43         | 3           | Horizontal | 65             | 2.86          | -       | 36.82      | 8.70       | 35.38      |

2.4-2.4835GHz\_802.11b\_Nss1,(1Mbps)\_1TX

2462MHz\_TX

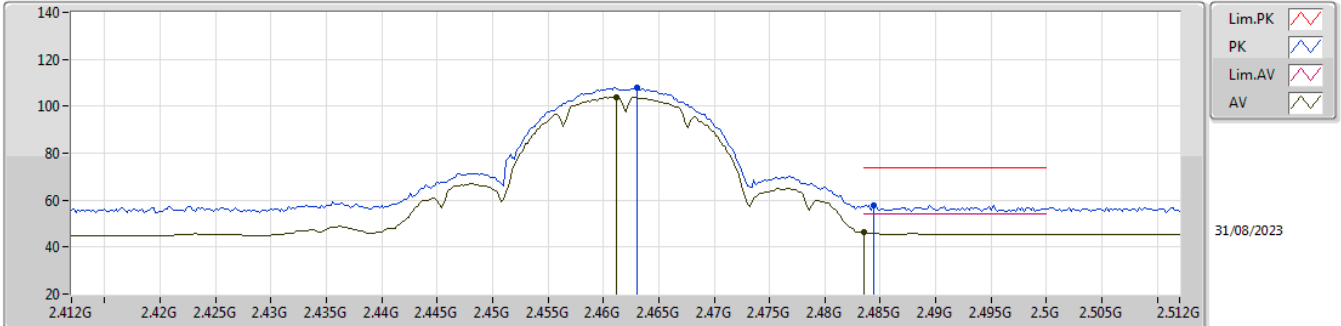

EUT\_Z\_1TX  
Setting 52  
03-E-R-7

| Type | Freq (Hz) | Level (dBuV/m) | Limit (dBuV/m) | Margin (dB) | Raw (dBuV) | Dist (m) | Condition | Azimuth (°) | Height (m) | Comment | AF (dB) | CL (dB) | PA (dB) |
|------|-----------|----------------|----------------|-------------|------------|----------|-----------|-------------|------------|---------|---------|---------|---------|
| PK   | 2.463G    | 107.69         | Inf            | -Inf        | 75.35      | 3        | Vertical  | 108         | 2.57       | -       | 28.28   | 4.06    | -       |
| AV   | 2.4612G   | 103.83         | Inf            | -Inf        | 71.50      | 3        | Vertical  | 108         | 2.57       | -       | 28.27   | 4.06    | -       |
| PK   | 2.4844G   | 57.82          | 74.00          | -16.18      | 25.33      | 3        | Vertical  | 108         | 2.57       | -       | 28.41   | 4.08    | -       |
| AV   | 2.4835G   | 46.33          | 54.00          | -7.67       | 13.85      | 3        | Vertical  | 108         | 2.57       | -       | 28.40   | 4.08    | -       |

2.4-2.4835GHz\_802.11b\_Nss1,(1Mbps)\_1TX

2462MHz\_TX

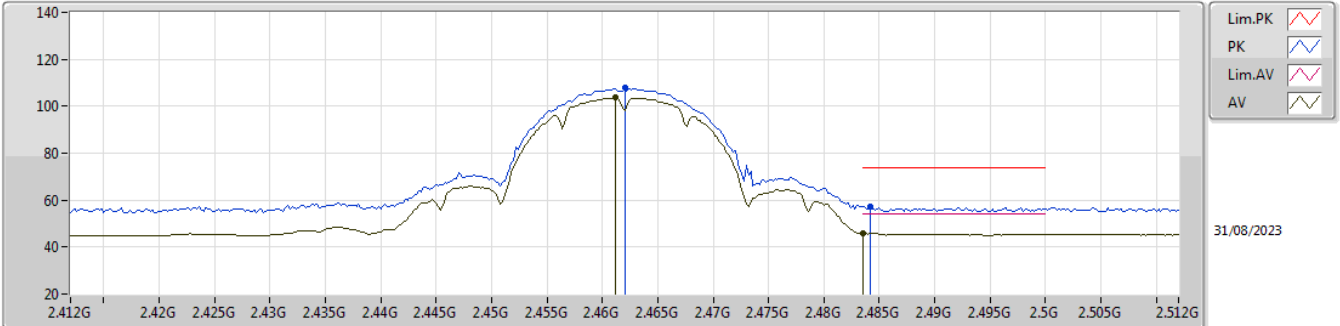

EUT\_Z\_1TX  
Setting 52  
03-E-R-7

| Type | Freq (Hz) | Level (dBuV/m) | Limit (dBuV/m) | Margin (dB) | Raw (dBuV) | Dist (m) | Condition  | Azimuth (°) | Height (m) | Comment | AF (dB) | CL (dB) | PA (dB) |
|------|-----------|----------------|----------------|-------------|------------|----------|------------|-------------|------------|---------|---------|---------|---------|
| PK   | 2.462G    | 108.04         | Inf            | -Inf        | 75.71      | 3        | Horizontal | 350         | 1.24       | -       | 28.27   | 4.06    | -       |
| AV   | 2.4612G   | 103.54         | Inf            | -Inf        | 71.21      | 3        | Horizontal | 350         | 1.24       | -       | 28.27   | 4.06    | -       |
| PK   | 2.4842G   | 57.42          | 74.00          | -16.58      | 24.93      | 3        | Horizontal | 350         | 1.24       | -       | 28.41   | 4.08    | -       |
| AV   | 2.4835G   | 46.09          | 54.00          | -7.91       | 13.61      | 3        | Horizontal | 350         | 1.24       | -       | 28.40   | 4.08    | -       |



2.4-2.4835GHz\_802.11b\_Nss1,(1Mbps)\_1TX

2462MHz\_TX

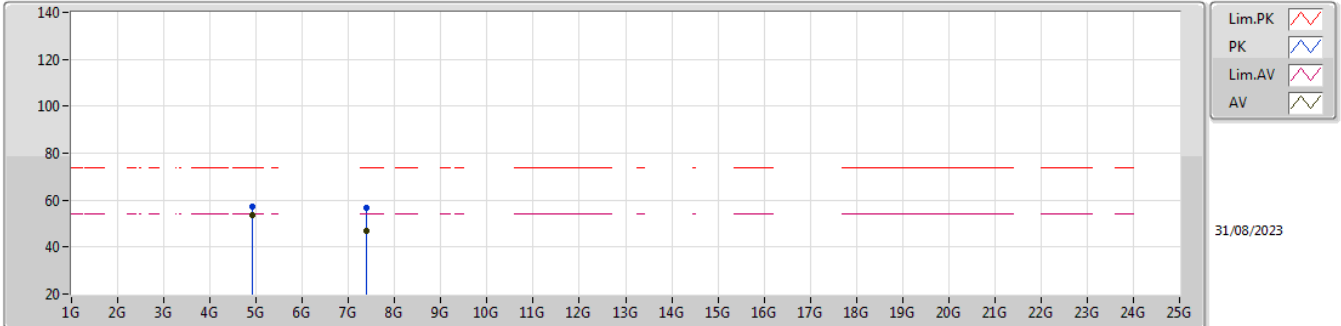

EUT\_Z\_1TX  
Setting 52  
03-E-R-7

| Type | Freq (Hz) | Level (dBuV/m) | Limit (dBuV/m) | Margin (dB) | Raw (dBuV) | Dist (m) | Condition | Azimuth (°) | Height (m) | Comment | AF (dB) | CL (dB) | PA (dB) |
|------|-----------|----------------|----------------|-------------|------------|----------|-----------|-------------|------------|---------|---------|---------|---------|
| PK   | 4.924G    | 57.07          | 74.00          | -16.93      | 51.63      | 3        | Vertical  | 262         | 1.03       | -       | 33.65   | 6.56    | 34.77   |
| AV   | 4.924G    | 53.82          | 54.00          | -0.18       | 48.38      | 3        | Vertical  | 262         | 1.03       | -       | 33.65   | 6.56    | 34.77   |
| PK   | 7.387G    | 56.47          | 74.00          | -17.53      | 46.21      | 3        | Vertical  | 105         | 1.00       | -       | 36.90   | 8.70    | 35.34   |
| AV   | 7.3867G   | 46.72          | 54.00          | -7.28       | 36.46      | 3        | Vertical  | 105         | 1.00       | -       | 36.90   | 8.70    | 35.34   |

2.4-2.4835GHz\_802.11b\_Nss1,(1Mbps)\_1TX

2462MHz\_TX

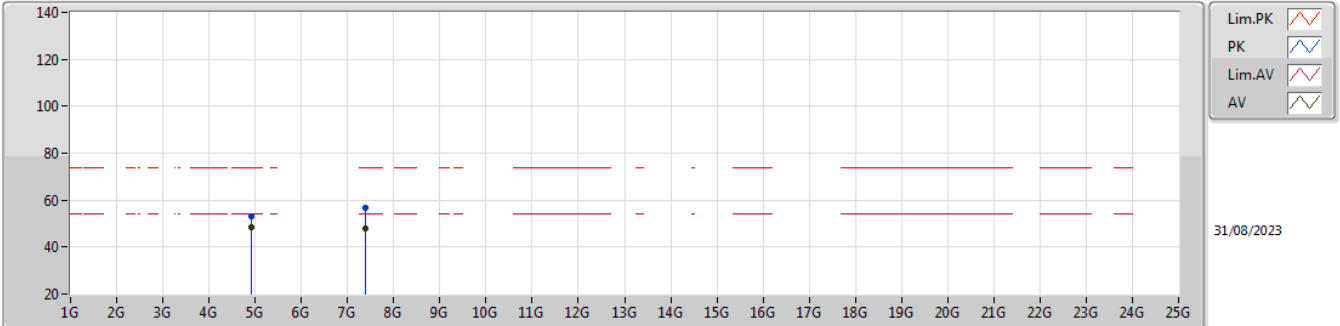

EUT\_Z\_1TX  
Setting 52  
03-E-R-7

| Type | Freq (Hz) | Level (dBuV/m) | Limit (dBuV/m) | Margin (dB) | Raw (dBuV) | Dist (m) | Condition  | Azimuth (°) | Height (m) | Comment | AF (dB) | CL (dB) | PA (dB) |
|------|-----------|----------------|----------------|-------------|------------|----------|------------|-------------|------------|---------|---------|---------|---------|
| PK   | 4.924G    | 53.19          | 74.00          | -20.81      | 47.75      | 3        | Horizontal | 11          | 2.75       | -       | 33.65   | 6.56    | 34.77   |
| AV   | 4.924G    | 48.41          | 54.00          | -5.59       | 42.97      | 3        | Horizontal | 11          | 2.75       | -       | 33.65   | 6.56    | 34.77   |
| PK   | 7.3865G   | 56.87          | 74.00          | -17.13      | 46.61      | 3        | Horizontal | 119         | 2.53       | -       | 36.90   | 8.70    | 35.34   |
| AV   | 7.3867G   | 47.96          | 54.00          | -6.04       | 37.70      | 3        | Horizontal | 119         | 2.53       | -       | 36.90   | 8.70    | 35.34   |

2.4-2.4835GHz\_802.11g\_Nss1,(6Mbps)\_1TX

2412MHz\_TX

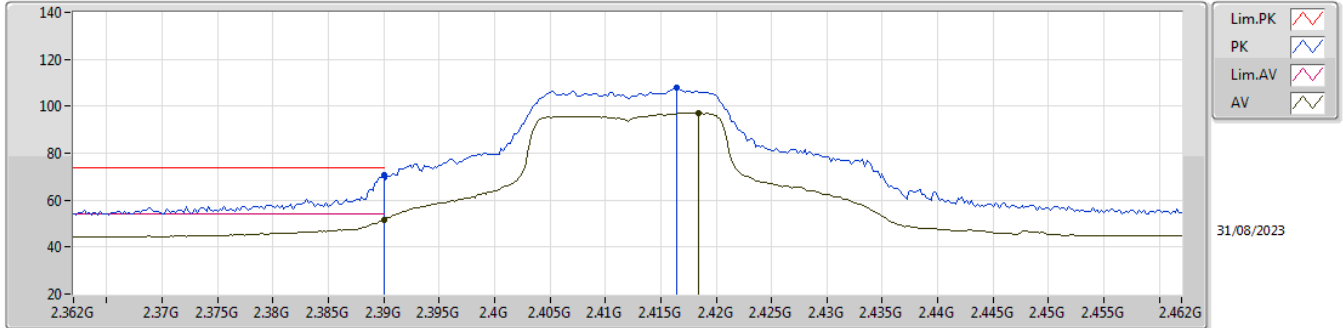

EUT\_Z\_1TX  
Setting 57  
03-E-R-7

| Type | Freq (Hz) | Level (dBuV/m) | Limit (dBuV/m) | Margin (dB) | Raw (dBuV) | Dist (m) | Condition | Azimuth (°) | Height (m) | Comment | AF (dB) | CL (dB) | PA (dB) |
|------|-----------|----------------|----------------|-------------|------------|----------|-----------|-------------|------------|---------|---------|---------|---------|
| PK   | 2.39G     | 70.68          | 74.00          | -3.32       | 38.49      | 3        | Vertical  | 229         | 2.42       | -       | 28.20   | 3.99    | -       |
| AV   | 2.39G     | 51.48          | 54.00          | -2.52       | 19.29      | 3        | Vertical  | 229         | 2.42       | -       | 28.20   | 3.99    | -       |
| PK   | 2.4164G   | 107.72         | Inf            | -Inf        | 75.50      | 3        | Vertical  | 229         | 2.42       | -       | 28.20   | 4.02    | -       |
| AV   | 2.4184G   | 97.17          | Inf            | -Inf        | 64.95      | 3        | Vertical  | 229         | 2.42       | -       | 28.20   | 4.02    | -       |

2.4-2.4835GHz\_802.11g\_Nss1,(6Mbps)\_1TX

2412MHz\_TX

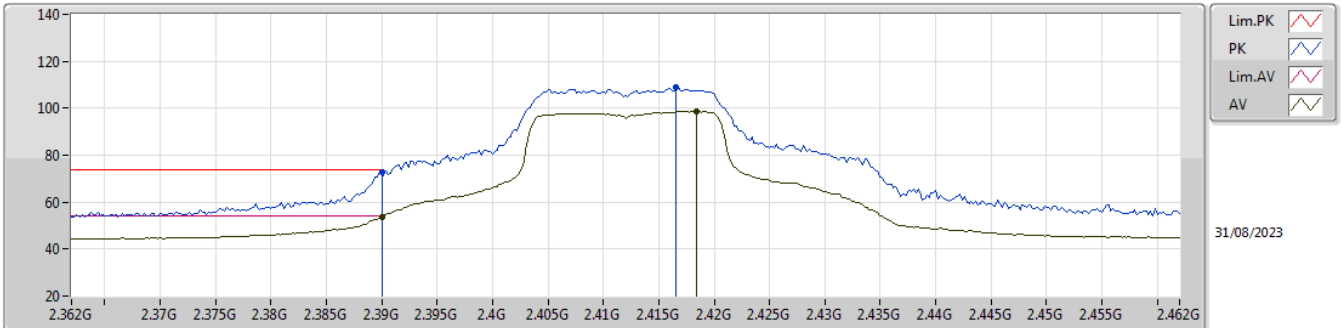

EUT\_Z\_1TX  
Setting 57  
03-E-R-7

| Type | Freq (Hz) | Level (dBuV/m) | Limit (dBuV/m) | Margin (dB) | Raw (dBuV) | Dist (m) | Condition  | Azimuth (°) | Height (m) | Comment | AF (dB) | CL (dB) | PA (dB) |
|------|-----------|----------------|----------------|-------------|------------|----------|------------|-------------|------------|---------|---------|---------|---------|
| PK   | 2.39G     | 72.96          | 74.00          | -1.04       | 40.77      | 3        | Horizontal | 348         | 1.01       | -       | 28.20   | 3.99    | -       |
| AV   | 2.39G     | 53.75          | 54.00          | -0.25       | 21.56      | 3        | Horizontal | 348         | 1.01       | -       | 28.20   | 3.99    | -       |
| PK   | 2.4166G   | 109.05         | Inf            | -Inf        | 76.83      | 3        | Horizontal | 348         | 1.01       | -       | 28.20   | 4.02    | -       |
| AV   | 2.4184G   | 98.60          | Inf            | -Inf        | 66.38      | 3        | Horizontal | 348         | 1.01       | -       | 28.20   | 4.02    | -       |

2.4-2.4835GHz\_802.11g\_Nss1,(6Mbps)\_1TX

2412MHz\_TX

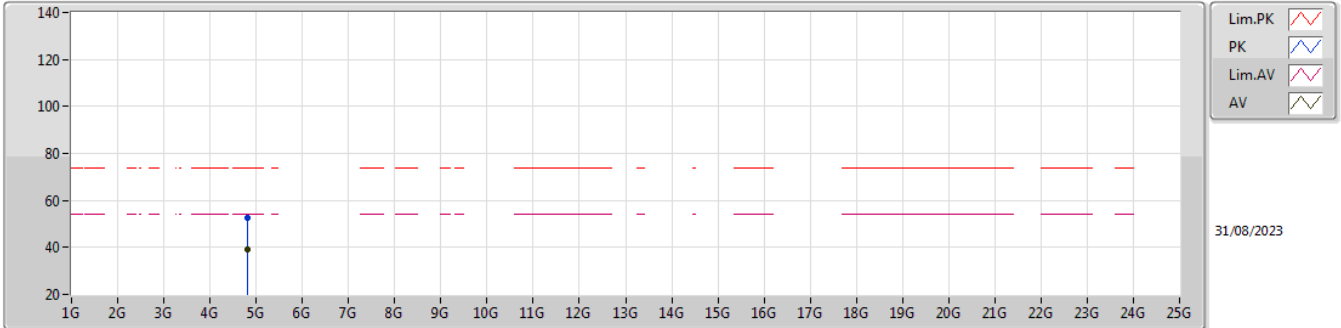

EUT\_Z\_1TX  
Setting 57  
03-E-R-7

| Type | Freq<br>(Hz) | Level<br>(dBuV/m) | Limit<br>(dBuV/m) | Margin<br>(dB) | Raw<br>(dBuV) | Dist<br>(m) | Condition | Azimuth<br>(°) | Height<br>(m) | Comment | AF<br>(dB) | CL<br>(dB) | PA<br>(dB) |
|------|--------------|-------------------|-------------------|----------------|---------------|-------------|-----------|----------------|---------------|---------|------------|------------|------------|
| PK   | 4.8197G      | 52.66             | 74.00             | -21.34         | 47.44         | 3           | Vertical  | 269            | 1.00          | -       | 33.40      | 6.51       | 34.69      |
| AV   | 4.8217G      | 39.08             | 54.00             | -14.92         | 33.86         | 3           | Vertical  | 269            | 1.00          | -       | 33.40      | 6.51       | 34.69      |

2.4-2.4835GHz\_802.11g\_Nss1,(6Mbps)\_1TX

2412MHz\_TX

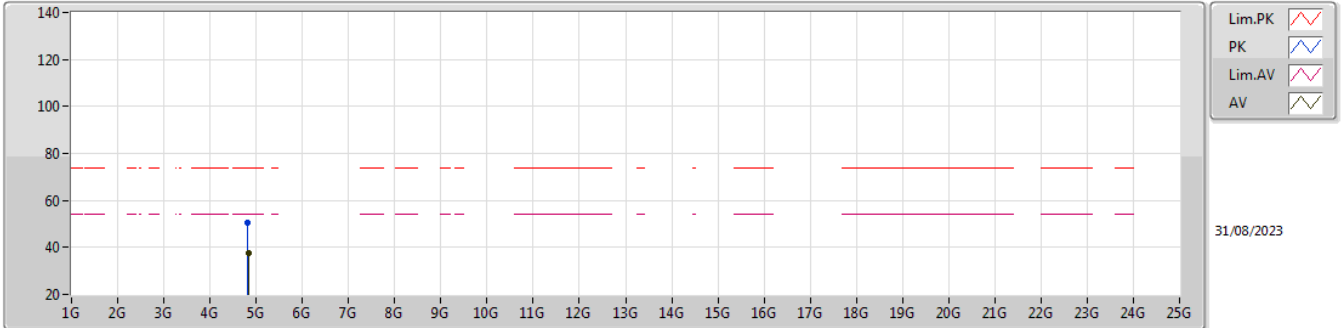

EUT\_Z\_1TX  
Setting 57  
03-E-R-7

| Type | Freq<br>(Hz) | Level<br>(dBuV/m) | Limit<br>(dBuV/m) | Margin<br>(dB) | Raw<br>(dBuV) | Dist<br>(m) | Condition  | Azimuth<br>(°) | Height<br>(m) | Comment | AF<br>(dB) | CL<br>(dB) | PA<br>(dB) |
|------|--------------|-------------------|-------------------|----------------|---------------|-------------|------------|----------------|---------------|---------|------------|------------|------------|
| PK   | 4.8187G      | 50.61             | 74.00             | -23.39         | 45.39         | 3           | Horizontal | 8              | 2.80          | -       | 33.40      | 6.51       | 34.69      |
| AV   | 4.8251G      | 37.78             | 54.00             | -16.22         | 32.56         | 3           | Horizontal | 8              | 2.80          | -       | 33.40      | 6.51       | 34.69      |

2.4-2.4835GHz\_802.11g\_Nss1,(6Mbps)\_1TX

2417MHz\_TX

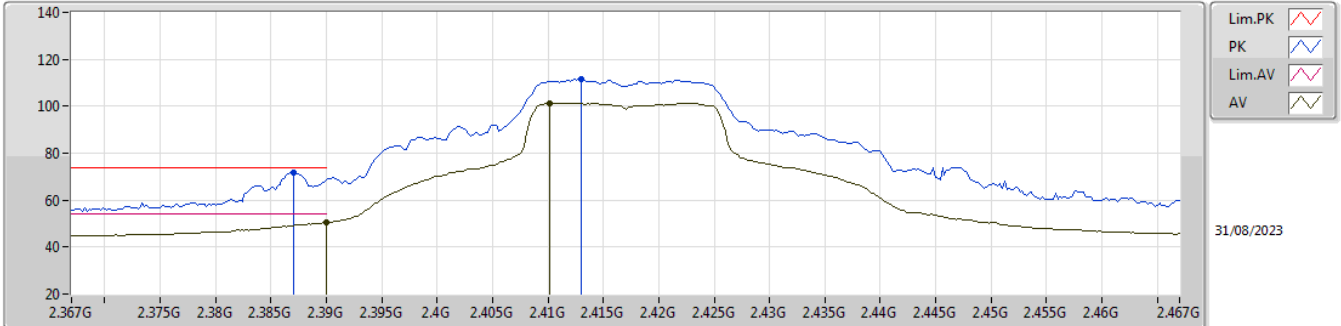

EUT\_Z\_1TX  
Setting 63  
03-E-R-7

| Type | Freq (Hz) | Level (dBuV/m) | Limit (dBuV/m) | Margin (dB) | Raw (dBuV) | Dist (m) | Condition | Azimuth (°) | Height (m) | Comment | AF (dB) | CL (dB) | PA (dB) |
|------|-----------|----------------|----------------|-------------|------------|----------|-----------|-------------|------------|---------|---------|---------|---------|
| PK   | 2.387G    | 71.75          | 74.00          | -2.25       | 39.56      | 3        | Vertical  | 93          | 3.00       | -       | 28.20   | 3.99    | -       |
| AV   | 2.39G     | 50.65          | 54.00          | -3.35       | 18.46      | 3        | Vertical  | 93          | 3.00       | -       | 28.20   | 3.99    | -       |
| PK   | 2.413G    | 111.71         | Inf            | -Inf        | 79.50      | 3        | Vertical  | 93          | 3.00       | -       | 28.20   | 4.01    | -       |
| AV   | 2.4102G   | 101.41         | Inf            | -Inf        | 69.20      | 3        | Vertical  | 93          | 3.00       | -       | 28.20   | 4.01    | -       |

2.4-2.4835GHz\_802.11g\_Nss1,(6Mbps)\_1TX

2417MHz\_TX

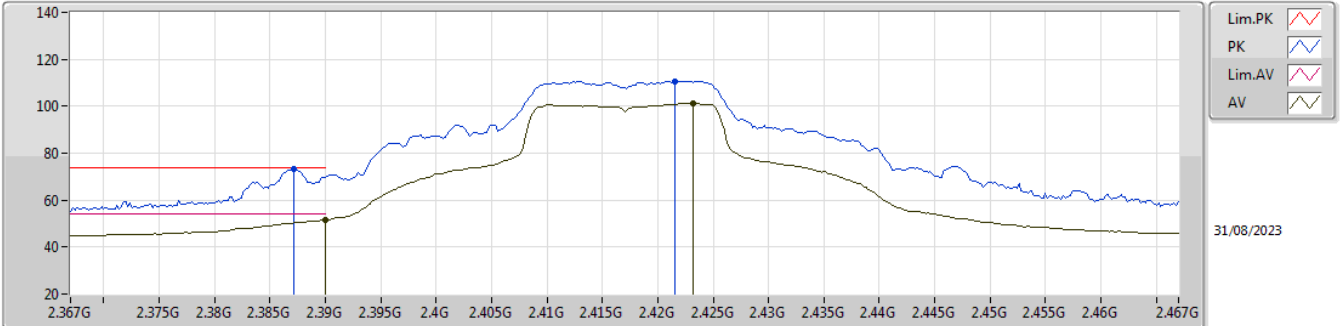

EUT\_Z\_1TX  
Setting 63  
03-E-R-7

| Type | Freq (Hz) | Level (dBuV/m) | Limit (dBuV/m) | Margin (dB) | Raw (dBuV) | Dist (m) | Condition  | Azimuth (°) | Height (m) | Comment | AF (dB) | CL (dB) | PA (dB) |
|------|-----------|----------------|----------------|-------------|------------|----------|------------|-------------|------------|---------|---------|---------|---------|
| PK   | 2.3872G   | 73.30          | 74.00          | -0.70       | 41.11      | 3        | Horizontal | 346         | 1.04       | -       | 28.20   | 3.99    | -       |
| AV   | 2.39G     | 51.79          | 54.00          | -2.21       | 19.60      | 3        | Horizontal | 346         | 1.04       | -       | 28.20   | 3.99    | -       |
| PK   | 2.4216G   | 110.77         | Inf            | -Inf        | 78.55      | 3        | Horizontal | 346         | 1.04       | -       | 28.20   | 4.02    | -       |
| AV   | 2.4232G   | 101.33         | Inf            | -Inf        | 69.11      | 3        | Horizontal | 346         | 1.04       | -       | 28.20   | 4.02    | -       |



2.4-2.4835GHz\_802.11g\_Nss1,(6Mbps)\_1TX

2437MHz\_TX

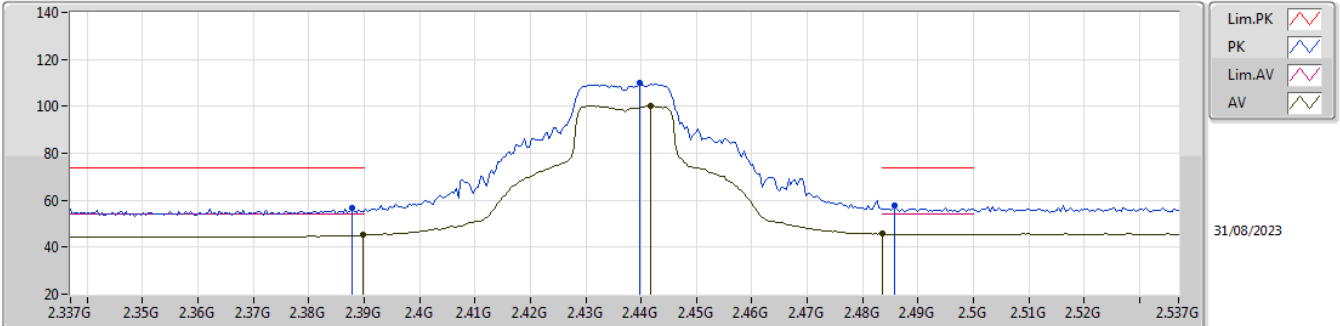

EUT\_Z\_1TX  
Setting 63  
03-E-R-7

| Type | Freq (Hz) | Level (dBuV/m) | Limit (dBuV/m) | Margin (dB) | Raw (dBuV) | Dist (m) | Condition | Azimuth (°) | Height (m) | Comment | AF (dB) | CL (dB) | PA (dB) |
|------|-----------|----------------|----------------|-------------|------------|----------|-----------|-------------|------------|---------|---------|---------|---------|
| PK   | 2.3878G   | 56.48          | 74.00          | -17.52      | 24.29      | 3        | Vertical  | 114         | 3.00       | -       | 28.20   | 3.99    | -       |
| AV   | 2.3898G   | 45.37          | 54.00          | -8.63       | 13.18      | 3        | Vertical  | 114         | 3.00       | -       | 28.20   | 3.99    | -       |
| PK   | 2.4398G   | 109.77         | Inf            | -Inf        | 77.53      | 3        | Vertical  | 114         | 3.00       | -       | 28.20   | 4.04    | -       |
| AV   | 2.4418G   | 100.19         | Inf            | -Inf        | 67.95      | 3        | Vertical  | 114         | 3.00       | -       | 28.20   | 4.04    | -       |
| PK   | 2.4858G   | 57.56          | 74.00          | -16.44      | 25.06      | 3        | Vertical  | 114         | 3.00       | -       | 28.41   | 4.09    | -       |
| AV   | 2.4835G   | 45.67          | 54.00          | -8.33       | 13.19      | 3        | Vertical  | 114         | 3.00       | -       | 28.40   | 4.08    | -       |

2.4-2.4835GHz\_802.11g\_Nss1,(6Mbps)\_1TX

2437MHz\_TX

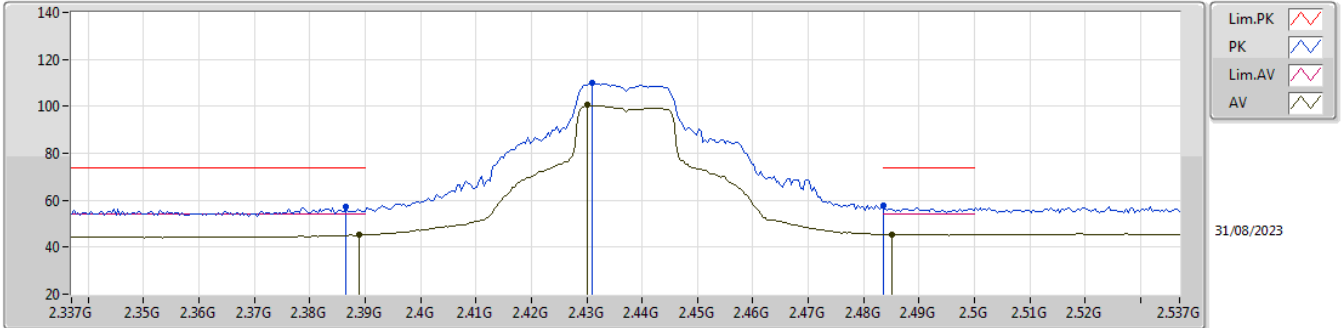

EUT\_Z\_1TX  
Setting 63  
03-E-R-7

| Type | Freq (Hz) | Level (dBuV/m) | Limit (dBuV/m) | Margin (dB) | Raw (dBuV) | Dist (m) | Condition  | Azimuth (°) | Height (m) | Comment | AF (dB) | CL (dB) | PA (dB) |
|------|-----------|----------------|----------------|-------------|------------|----------|------------|-------------|------------|---------|---------|---------|---------|
| PK   | 2.3866G   | 56.99          | 74.00          | -17.01      | 24.80      | 3        | Horizontal | 346         | 1.28       | -       | 28.20   | 3.99    | -       |
| AV   | 2.389G    | 45.31          | 54.00          | -8.69       | 13.12      | 3        | Horizontal | 346         | 1.28       | -       | 28.20   | 3.99    | -       |
| PK   | 2.431G    | 109.85         | Inf            | -Inf        | 77.62      | 3        | Horizontal | 346         | 1.28       | -       | 28.20   | 4.03    | -       |
| AV   | 2.4302G   | 100.47         | Inf            | -Inf        | 68.24      | 3        | Horizontal | 346         | 1.28       | -       | 28.20   | 4.03    | -       |
| PK   | 2.4835G   | 57.71          | 74.00          | -16.29      | 25.23      | 3        | Horizontal | 346         | 1.28       | -       | 28.40   | 4.08    | -       |
| AV   | 2.485G    | 45.51          | 54.00          | -8.49       | 13.02      | 3        | Horizontal | 346         | 1.28       | -       | 28.41   | 4.08    | -       |

2.4-2.4835GHz\_802.11g\_Nss1,(6Mbps)\_1TX

2437MHz\_TX

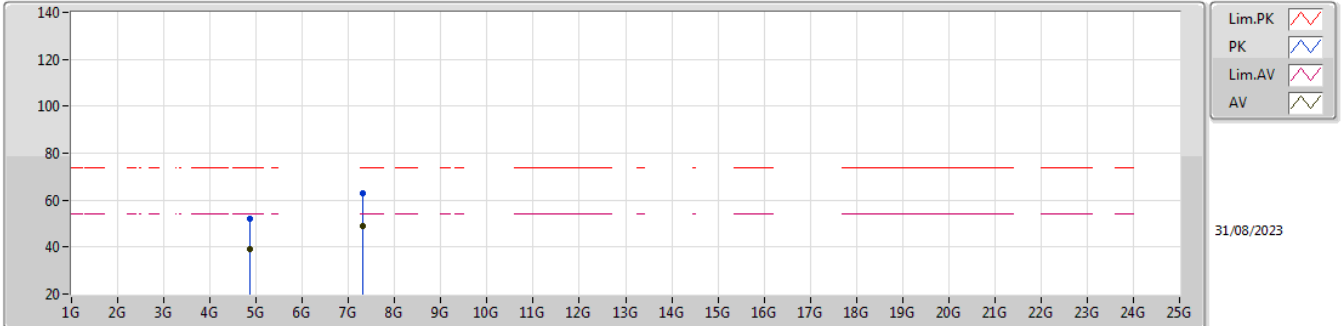

EUT\_Z\_1TX  
Setting 63  
03-E-R-7

| Type | Freq<br>(Hz) | Level<br>(dBuV/m) | Limit<br>(dBuV/m) | Margin<br>(dB) | Raw<br>(dBuV) | Dist<br>(m) | Condition | Azimuth<br>(°) | Height<br>(m) | Comment | AF<br>(dB) | CL<br>(dB) | PA<br>(dB) |
|------|--------------|-------------------|-------------------|----------------|---------------|-------------|-----------|----------------|---------------|---------|------------|------------|------------|
| PK   | 4.8723G      | 51.86             | 74.00             | -22.14         | 46.52         | 3           | Vertical  | 262            | 1.03          | -       | 33.53      | 6.54       | 34.73      |
| AV   | 4.8755G      | 38.97             | 54.00             | -15.03         | 33.61         | 3           | Vertical  | 262            | 1.03          | -       | 33.55      | 6.54       | 34.73      |
| PK   | 7.3073G      | 62.68             | 74.00             | -11.32         | 52.55         | 3           | Vertical  | 110            | 1.01          | -       | 36.81      | 8.70       | 35.38      |
| AV   | 7.3147G      | 49.00             | 54.00             | -5.00          | 38.85         | 3           | Vertical  | 110            | 1.01          | -       | 36.83      | 8.70       | 35.38      |

2.4-2.4835GHz\_802.11g\_Nss1,(6Mbps)\_1TX

2437MHz\_TX

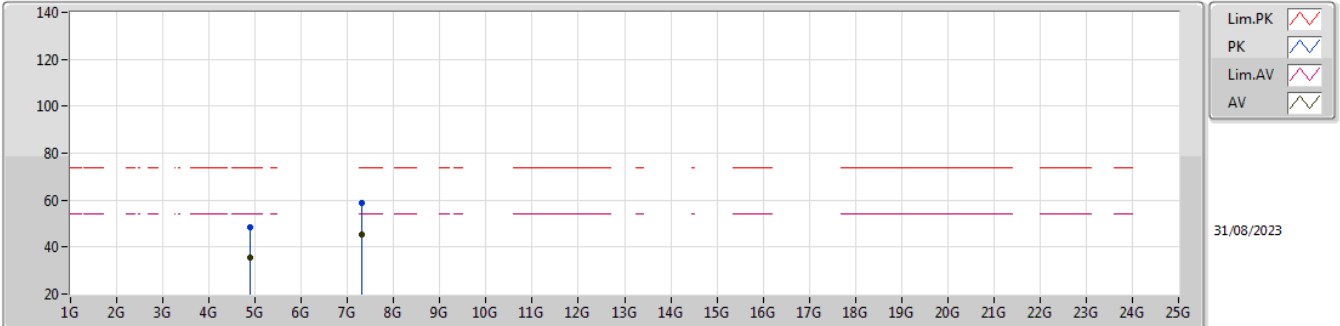

EUT\_Z\_1TX  
Setting 63  
03-E-R-7

| Type | Freq<br>(Hz) | Level<br>(dBuV/m) | Limit<br>(dBuV/m) | Margin<br>(dB) | Raw<br>(dBuV) | Dist<br>(m) | Condition  | Azimuth<br>(°) | Height<br>(m) | Comment | AF<br>(dB) | CL<br>(dB) | PA<br>(dB) |
|------|--------------|-------------------|-------------------|----------------|---------------|-------------|------------|----------------|---------------|---------|------------|------------|------------|
| PK   | 4.8919G      | 48.47             | 74.00             | -25.53         | 43.02         | 3           | Horizontal | 210            | 2.41          | -       | 33.65      | 6.55       | 34.75      |
| AV   | 4.8793G      | 35.69             | 54.00             | -18.31         | 30.31         | 3           | Horizontal | 210            | 2.41          | -       | 33.58      | 6.54       | 34.74      |
| PK   | 7.3099G      | 58.57             | 74.00             | -15.43         | 48.43         | 3           | Horizontal | 66             | 2.49          | -       | 36.82      | 8.70       | 35.38      |
| AV   | 7.3168G      | 45.28             | 54.00             | -8.72          | 35.13         | 3           | Horizontal | 66             | 2.49          | -       | 36.83      | 8.70       | 35.38      |

2.4-2.4835GHz\_802.11g\_Nss1,(6Mbps)\_1TX

2457MHz\_TX

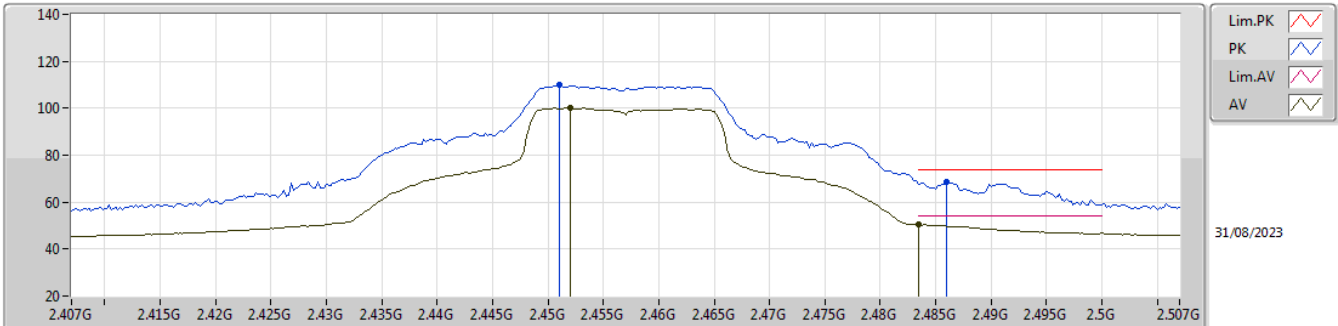

EUT\_Z\_1TX  
Setting 63  
03-E-R-7

| Type | Freq (Hz) | Level (dBuV/m) | Limit (dBuV/m) | Margin (dB) | Raw (dBuV) | Dist (m) | Condition | Azimuth (°) | Height (m) | Comment | AF (dB) | CL (dB) | PA (dB) |
|------|-----------|----------------|----------------|-------------|------------|----------|-----------|-------------|------------|---------|---------|---------|---------|
| PK   | 2.451G    | 109.99         | Inf            | -Inf        | 77.73      | 3        | Vertical  | 112         | 2.52       | -       | 28.21   | 4.05    | -       |
| AV   | 2.452G    | 100.03         | Inf            | -Inf        | 67.77      | 3        | Vertical  | 112         | 2.52       | -       | 28.21   | 4.05    | -       |
| PK   | 2.486G    | 68.48          | 74.00          | -5.52       | 35.97      | 3        | Vertical  | 112         | 2.52       | -       | 28.42   | 4.09    | -       |
| AV   | 2.4835G   | 50.51          | 54.00          | -3.49       | 18.03      | 3        | Vertical  | 112         | 2.52       | -       | 28.40   | 4.08    | -       |

2.4-2.4835GHz\_802.11g\_Nss1,(6Mbps)\_1TX

2457MHz\_TX

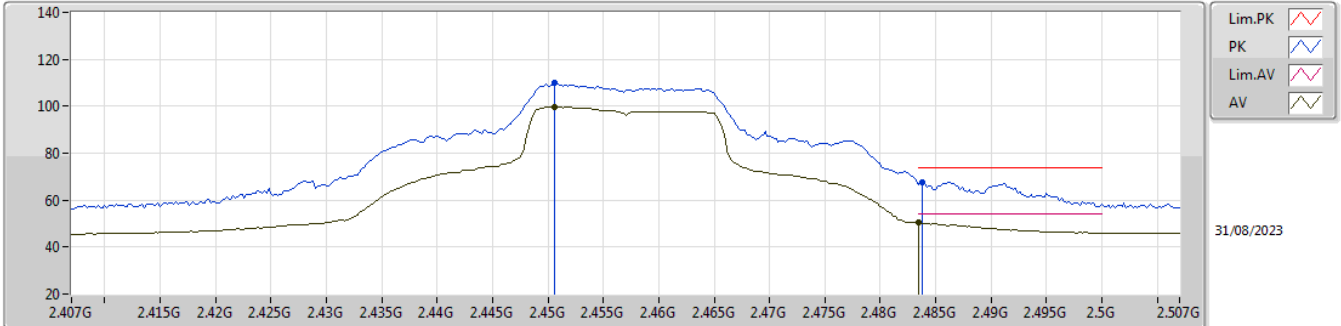

EUT\_Z\_1TX  
Setting 63  
03-E-R-7

| Type | Freq (Hz) | Level (dBuV/m) | Limit (dBuV/m) | Margin (dB) | Raw (dBuV) | Dist (m) | Condition  | Azimuth (°) | Height (m) | Comment | AF (dB) | CL (dB) | PA (dB) |
|------|-----------|----------------|----------------|-------------|------------|----------|------------|-------------|------------|---------|---------|---------|---------|
| PK   | 2.4506G   | 109.97         | Inf            | -Inf        | 77.72      | 3        | Horizontal | 351         | 1.64       | -       | 28.20   | 4.05    | -       |
| AV   | 2.4506G   | 99.62          | Inf            | -Inf        | 67.37      | 3        | Horizontal | 351         | 1.64       | -       | 28.20   | 4.05    | -       |
| PK   | 2.4838G   | 67.58          | 74.00          | -6.42       | 35.10      | 3        | Horizontal | 351         | 1.64       | -       | 28.40   | 4.08    | -       |
| AV   | 2.4835G   | 50.30          | 54.00          | -3.70       | 17.82      | 3        | Horizontal | 351         | 1.64       | -       | 28.40   | 4.08    | -       |

2.4-2.4835GHz\_802.11g\_Nss1,(6Mbps)\_1TX

2462MHz\_TX

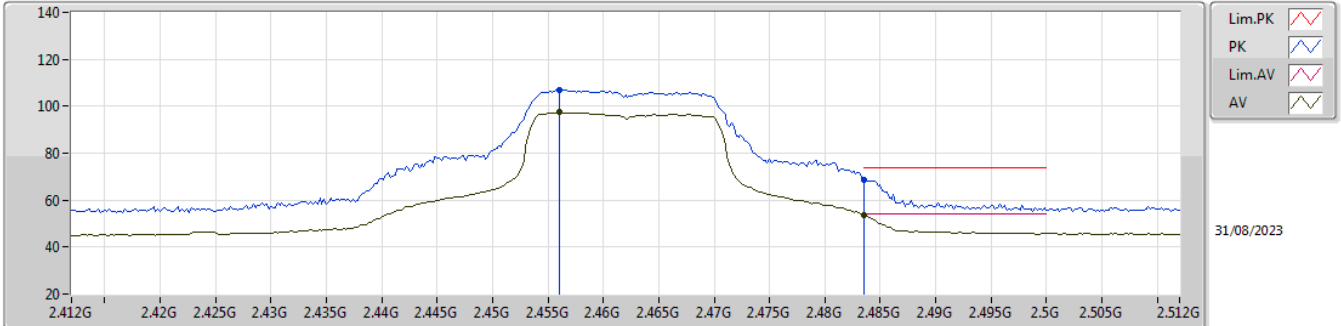

EUT\_Z\_1TX  
 Setting 56  
 03-E-R-7

| Type | Freq (Hz) | Level (dBuV/m) | Limit (dBuV/m) | Margin (dB) | Raw (dBuV) | Dist (m) | Condition | Azimuth (°) | Height (m) | Comment | AF (dB) | CL (dB) | PA (dB) |
|------|-----------|----------------|----------------|-------------|------------|----------|-----------|-------------|------------|---------|---------|---------|---------|
| PK   | 2.456G    | 106.78         | Inf            | -Inf        | 74.48      | 3        | Vertical  | 110         | 2.53       | -       | 28.24   | 4.06    | -       |
| AV   | 2.456G    | 97.34          | Inf            | -Inf        | 65.04      | 3        | Vertical  | 110         | 2.53       | -       | 28.24   | 4.06    | -       |
| PK   | 2.4835G   | 68.82          | 74.00          | -5.18       | 36.34      | 3        | Vertical  | 110         | 2.53       | -       | 28.40   | 4.08    | -       |
| AV   | 2.4835G   | 53.81          | 54.00          | -0.19       | 21.33      | 3        | Vertical  | 110         | 2.53       | -       | 28.40   | 4.08    | -       |

2.4-2.4835GHz\_802.11g\_Nss1,(6Mbps)\_1TX

2462MHz\_TX

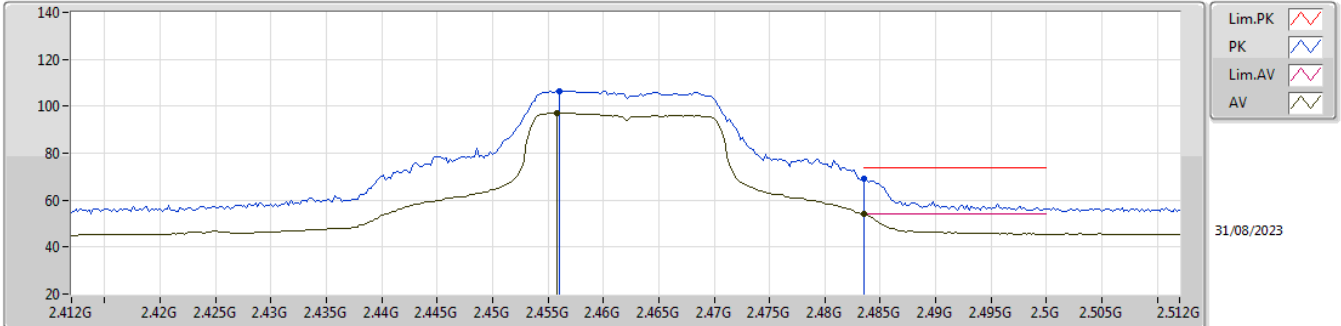

EUT\_Z\_1TX  
Setting 56  
03-E-R-7

| Type | Freq (Hz) | Level (dBuV/m) | Limit (dBuV/m) | Margin (dB) | Raw (dBuV) | Dist (m) | Condition  | Azimuth (°) | Height (m) | Comment | AF (dB) | CL (dB) | PA (dB) |
|------|-----------|----------------|----------------|-------------|------------|----------|------------|-------------|------------|---------|---------|---------|---------|
| PK   | 2.456G    | 106.56         | Inf            | -Inf        | 74.26      | 3        | Horizontal | 348         | 1.02       | -       | 28.24   | 4.06    | -       |
| AV   | 2.4558G   | 97.24          | Inf            | -Inf        | 64.95      | 3        | Horizontal | 348         | 1.02       | -       | 28.23   | 4.06    | -       |
| PK   | 2.4835G   | 69.23          | 74.00          | -4.77       | 36.75      | 3        | Horizontal | 348         | 1.02       | -       | 28.40   | 4.08    | -       |
| AV   | 2.4835G   | 53.97          | 54.00          | -0.03       | 21.49      | 3        | Horizontal | 348         | 1.02       | -       | 28.40   | 4.08    | -       |



2.4-2.4835GHz\_802.11g\_Nss1,(6Mbps)\_1TX

2462MHz\_TX

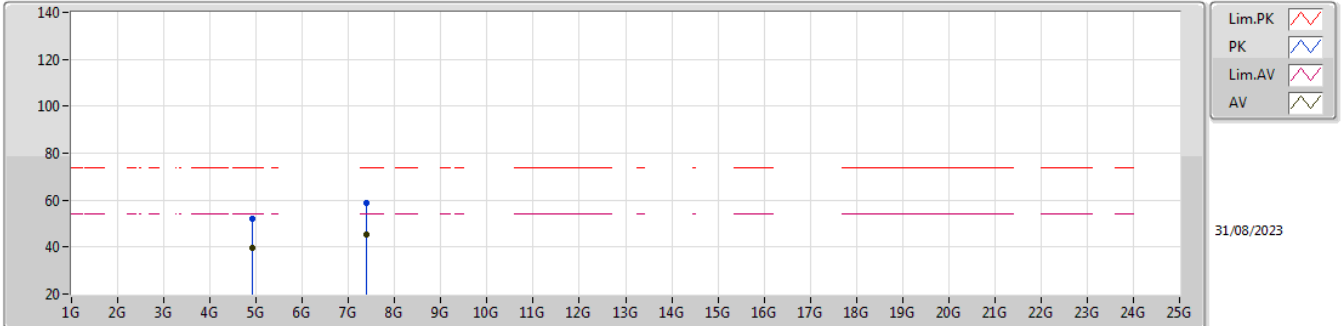

EUT\_Z\_1TX  
Setting 56  
03-E-R-7

| Type | Freq<br>(Hz) | Level<br>(dBuV/m) | Limit<br>(dBuV/m) | Margin<br>(dB) | Raw<br>(dBuV) | Dist<br>(m) | Condition | Azimuth<br>(°) | Height<br>(m) | Comment | AF<br>(dB) | CL<br>(dB) | PA<br>(dB) |
|------|--------------|-------------------|-------------------|----------------|---------------|-------------|-----------|----------------|---------------|---------|------------|------------|------------|
| PK   | 4.9284G      | 52.13             | 74.00             | -21.87         | 46.70         | 3           | Vertical  | 270            | 1.04          | -       | 33.64      | 6.56       | 34.77      |
| AV   | 4.9234G      | 39.57             | 54.00             | -14.43         | 34.13         | 3           | Vertical  | 270            | 1.04          | -       | 33.65      | 6.56       | 34.77      |
| PK   | 7.3881G      | 58.69             | 74.00             | -15.31         | 48.42         | 3           | Vertical  | 110            | 1.00          | -       | 36.90      | 8.70       | 35.33      |
| AV   | 7.3853G      | 45.20             | 54.00             | -8.80          | 34.94         | 3           | Vertical  | 110            | 1.00          | -       | 36.90      | 8.70       | 35.34      |

2.4-2.4835GHz\_802.11g\_Nss1,(6Mbps)\_1TX

2462MHz\_TX

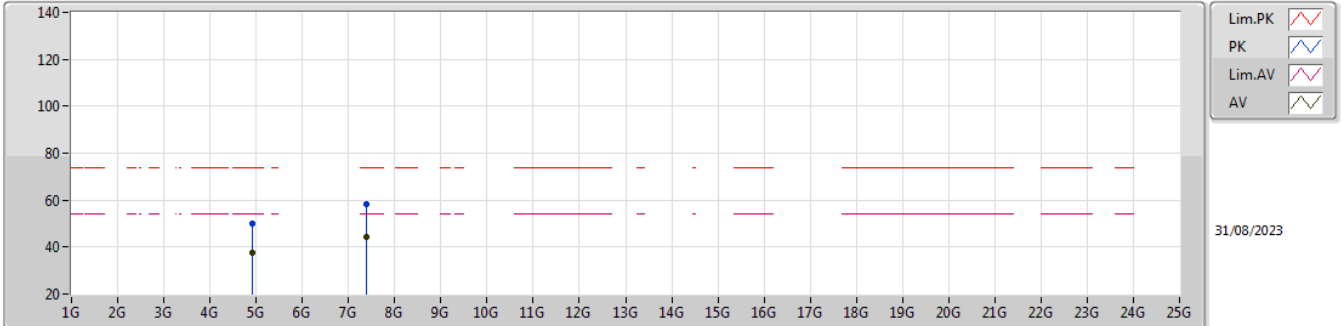

EUT\_Z\_1TX  
Setting 56  
03-E-R-7

| Type | Freq (Hz) | Level (dBuV/m) | Limit (dBuV/m) | Margin (dB) | Raw (dBuV) | Dist (m) | Condition  | Azimuth (°) | Height (m) | Comment | AF (dB) | CL (dB) | PA (dB) |
|------|-----------|----------------|----------------|-------------|------------|----------|------------|-------------|------------|---------|---------|---------|---------|
| PK   | 4.922G    | 50.03          | 74.00          | -23.97      | 44.58      | 3        | Horizontal | 360         | 3.00       | -       | 33.66   | 6.56    | 34.77   |
| AV   | 4.9248G   | 37.50          | 54.00          | -16.50      | 32.06      | 3        | Horizontal | 360         | 3.00       | -       | 33.65   | 6.56    | 34.77   |
| PK   | 7.3868G   | 58.02          | 74.00          | -15.98      | 47.76      | 3        | Horizontal | 115         | 3.00       | -       | 36.90   | 8.70    | 35.34   |
| AV   | 7.3867G   | 44.39          | 54.00          | -9.61       | 34.13      | 3        | Horizontal | 115         | 3.00       | -       | 36.90   | 8.70    | 35.34   |

2.4-2.4835GHz\_802.11n\_HT20\_Nss1,(MCS0)\_1TX

2412MHz\_TX

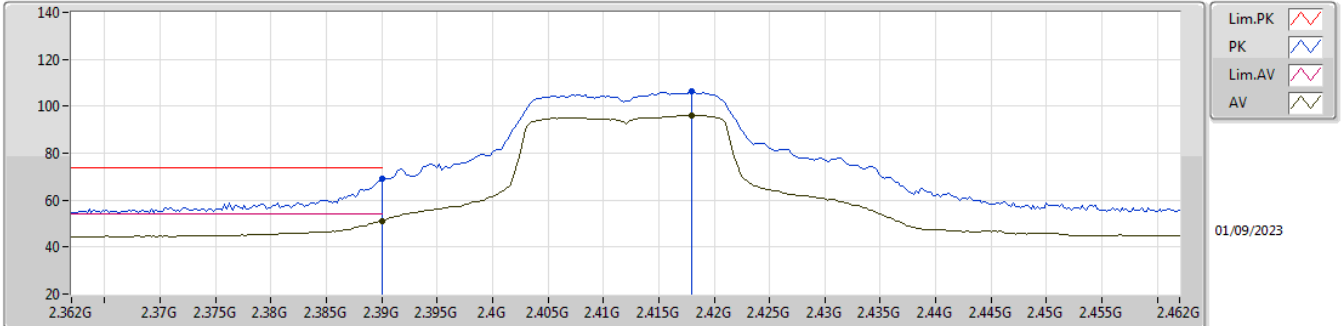

EUT\_Z\_1TX  
Setting 55  
03-E-R-7

| Type | Freq (Hz) | Level (dBuV/m) | Limit (dBuV/m) | Margin (dB) | Raw (dBuV) | Dist (m) | Condition | Azimuth (°) | Height (m) | Comment | AF (dB) | CL (dB) | PA (dB) |
|------|-----------|----------------|----------------|-------------|------------|----------|-----------|-------------|------------|---------|---------|---------|---------|
| PK   | 2.39G     | 68.91          | 74.00          | -5.09       | 36.72      | 3        | Vertical  | 230         | 2.41       | -       | 28.20   | 3.99    | -       |
| AV   | 2.39G     | 51.29          | 54.00          | -2.71       | 19.10      | 3        | Vertical  | 230         | 2.41       | -       | 28.20   | 3.99    | -       |
| PK   | 2.418G    | 106.34         | Inf            | -Inf        | 74.12      | 3        | Vertical  | 230         | 2.41       | -       | 28.20   | 4.02    | -       |
| AV   | 2.418G    | 96.05          | Inf            | -Inf        | 63.83      | 3        | Vertical  | 230         | 2.41       | -       | 28.20   | 4.02    | -       |

2.4-2.4835GHz\_802.11n\_HT20\_Nss1,(MCS0)\_1TX

2412MHz\_TX

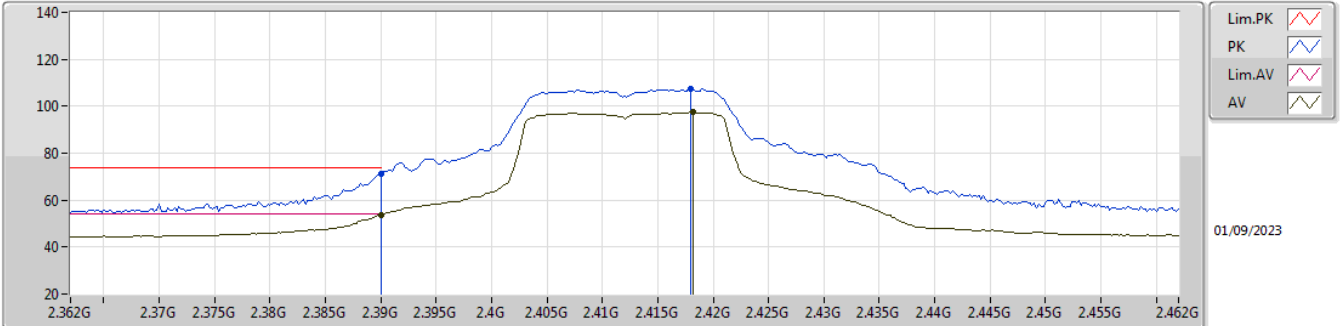

EUT\_Z\_1TX  
Setting 55  
03-E-R-7

| Type | Freq (Hz) | Level (dBuV/m) | Limit (dBuV/m) | Margin (dB) | Raw (dBuV) | Dist (m) | Condition  | Azimuth (°) | Height (m) | Comment | AF (dB) | CL (dB) | PA (dB) |
|------|-----------|----------------|----------------|-------------|------------|----------|------------|-------------|------------|---------|---------|---------|---------|
| PK   | 2.39G     | 71.44          | 74.00          | -2.56       | 39.25      | 3        | Horizontal | 345         | 1.00       | -       | 28.20   | 3.99    | -       |
| AV   | 2.39G     | 53.61          | 54.00          | -0.39       | 21.42      | 3        | Horizontal | 345         | 1.00       | -       | 28.20   | 3.99    | -       |
| PK   | 2.418G    | 107.65         | Inf            | -Inf        | 75.43      | 3        | Horizontal | 345         | 1.00       | -       | 28.20   | 4.02    | -       |
| AV   | 2.4182G   | 97.35          | Inf            | -Inf        | 65.13      | 3        | Horizontal | 345         | 1.00       | -       | 28.20   | 4.02    | -       |

2.4-2.4835GHz\_802.11n\_HT20\_Nss1,(MCS0)\_1TX

2412MHz\_TX

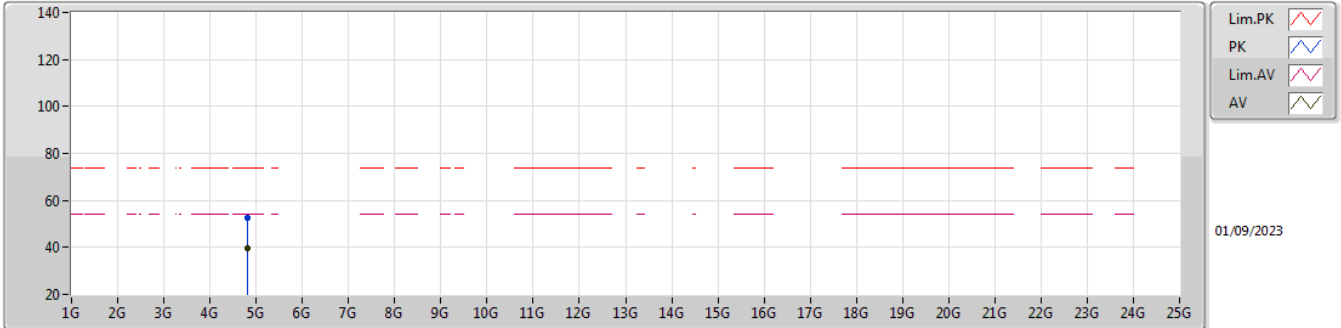

EUT\_Z\_1TX  
Setting 55  
03-E-R-7

| Type | Freq    | Level    | Limit    | Margin | Raw    | Dist | Condition | Azimuth | Height | Comment | AF    | CL   | PA    |  |  |  |
|------|---------|----------|----------|--------|--------|------|-----------|---------|--------|---------|-------|------|-------|--|--|--|
|      | (Hz)    | (dBuV/m) | (dBuV/m) | (dB)   | (dBuV) | (m)  |           | (°)     | (m)    |         | (dB)  | (dB) | (dB)  |  |  |  |
| PK   | 4.8205G | 52.40    | 74.00    | -21.60 | 47.18  | 3    | Vertical  | 270     | 1.10   | -       | 33.40 | 6.51 | 34.69 |  |  |  |
| AV   | 4.8216G | 39.44    | 54.00    | -14.56 | 34.22  | 3    | Vertical  | 270     | 1.10   | -       | 33.40 | 6.51 | 34.69 |  |  |  |

2.4-2.4835GHz\_802.11n\_HT20\_Nss1,(MCS0)\_1TX

2412MHz\_TX

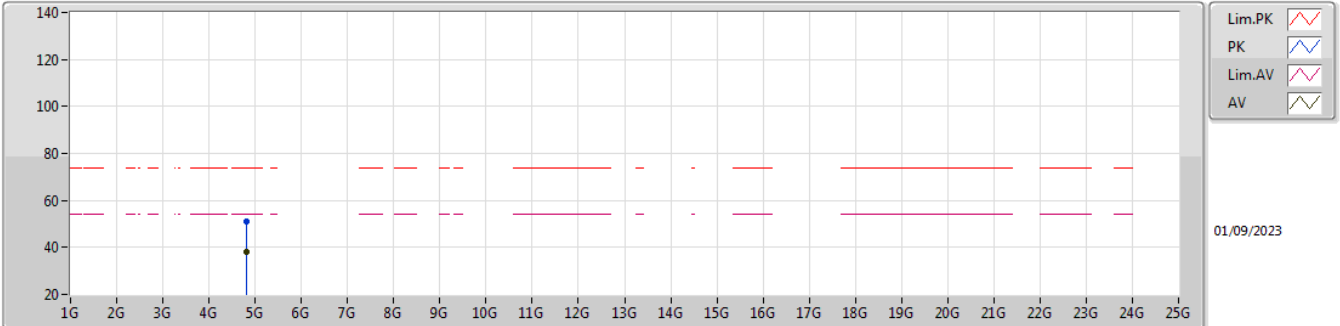

EUT\_Z\_1TX  
Setting 55  
03-E-R-7

| Type | Freq<br>(Hz) | Level<br>(dBuV/m) | Limit<br>(dBuV/m) | Margin<br>(dB) | Raw<br>(dBuV) | Dist<br>(m) | Condition  | Azimuth<br>(°) | Height<br>(m) | Comment | AF<br>(dB) | CL<br>(dB) | PA<br>(dB) |
|------|--------------|-------------------|-------------------|----------------|---------------|-------------|------------|----------------|---------------|---------|------------|------------|------------|
| PK   | 4.8218G      | 50.86             | 74.00             | -23.14         | 45.64         | 3           | Horizontal | 5              | 2.90          | -       | 33.40      | 6.51       | 34.69      |
| AV   | 4.8216G      | 38.31             | 54.00             | -15.69         | 33.09         | 3           | Horizontal | 5              | 2.90          | -       | 33.40      | 6.51       | 34.69      |

2.4-2.4835GHz\_802.11n\_HT20\_Nss1,(MCS0)\_1TX

2417MHz\_TX

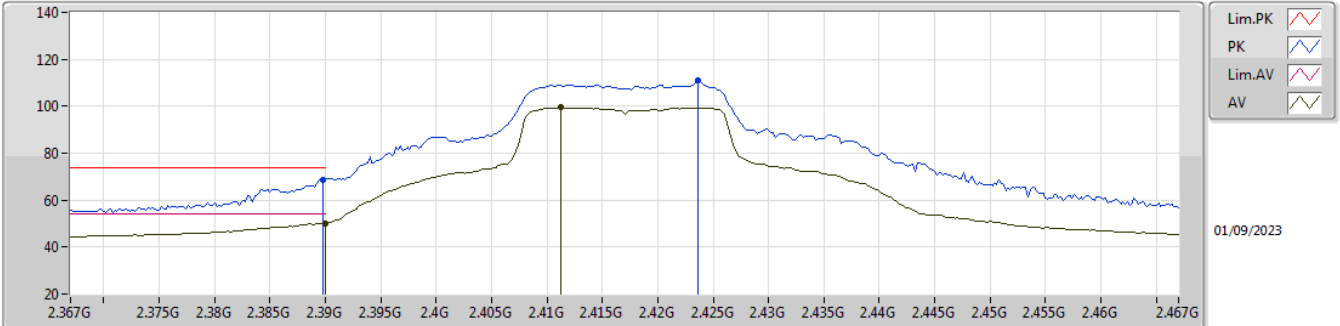

EUT\_Z\_1TX  
Setting 63  
03-C-W-4

| Type | Freq (Hz) | Level (dBuV/m) | Limit (dBuV/m) | Margin (dB) | Raw (dBuV) | Dist (m) | Condition | Azimuth (°) | Height (m) | Comment | AF (dB) | CL (dB) | PA (dB) |
|------|-----------|----------------|----------------|-------------|------------|----------|-----------|-------------|------------|---------|---------|---------|---------|
| PK   | 2.3898G   | 68.79          | 74.00          | -5.21       | 36.60      | 3        | Vertical  | 97          | 3.00       | -       | 28.20   | 3.99    | -       |
| AV   | 2.39G     | 50.23          | 54.00          | -3.77       | 18.04      | 3        | Vertical  | 97          | 3.00       | -       | 28.20   | 3.99    | -       |
| PK   | 2.4236G   | 110.86         | Inf            | -Inf        | 78.64      | 3        | Vertical  | 97          | 3.00       | -       | 28.20   | 4.02    | -       |
| AV   | 2.4112G   | 99.45          | Inf            | -Inf        | 67.24      | 3        | Vertical  | 97          | 3.00       | -       | 28.20   | 4.01    | -       |

2.4-2.4835GHz\_802.11n\_HT20\_Nss1,(MCS0)\_1TX

2417MHz\_TX

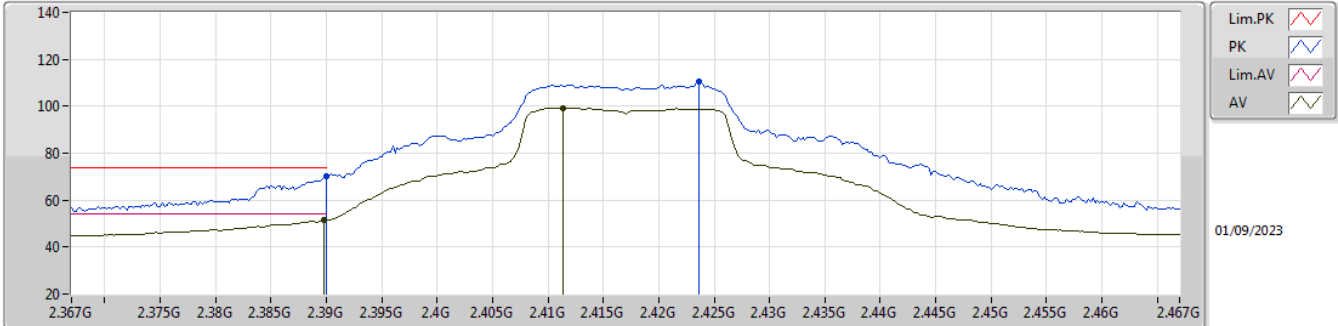

EUT\_Z\_1TX  
 Setting 63  
 03-C-W-4

| Type | Freq (Hz) | Level (dBuV/m) | Limit (dBuV/m) | Margin (dB) | Raw (dBuV) | Dist (m) | Condition  | Azimuth (°) | Height (m) | Comment | AF (dB) | CL (dB) | PA (dB) |
|------|-----------|----------------|----------------|-------------|------------|----------|------------|-------------|------------|---------|---------|---------|---------|
| PK   | 2.39G     | 70.04          | 74.00          | -3.96       | 37.85      | 3        | Horizontal | 336         | 1.01       | -       | 28.20   | 3.99    | -       |
| AV   | 2.3898G   | 51.34          | 54.00          | -2.66       | 19.15      | 3        | Horizontal | 336         | 1.01       | -       | 28.20   | 3.99    | -       |
| PK   | 2.4236G   | 110.51         | Inf            | -Inf        | 78.29      | 3        | Horizontal | 336         | 1.01       | -       | 28.20   | 4.02    | -       |
| AV   | 2.4114G   | 99.31          | Inf            | -Inf        | 67.10      | 3        | Horizontal | 336         | 1.01       | -       | 28.20   | 4.01    | -       |



2.4-2.4835GHz\_802.11n\_HT20\_Nss1,(MCS0)\_1TX

2437MHz\_TX

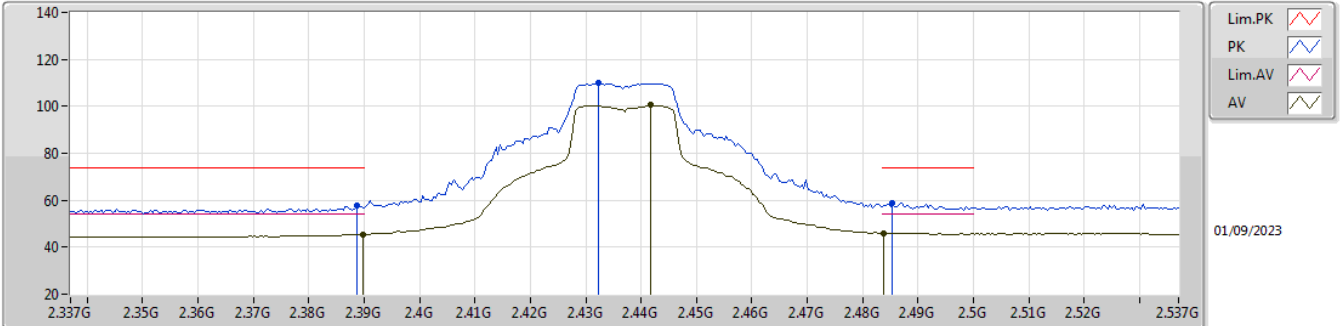

EUT\_Z\_1TX  
Setting 63  
03-E-R-7

| Type | Freq (Hz) | Level (dBuV/m) | Limit (dBuV/m) | Margin (dB) | Raw (dBuV) | Dist (m) | Condition | Azimuth (°) | Height (m) | Comment | AF (dB) | CL (dB) | PA (dB) |
|------|-----------|----------------|----------------|-------------|------------|----------|-----------|-------------|------------|---------|---------|---------|---------|
| PK   | 2.3886G   | 57.65          | 74.00          | -16.35      | 25.46      | 3        | Vertical  | 114         | 3.00       | -       | 28.20   | 3.99    | -       |
| AV   | 2.3898G   | 45.38          | 54.00          | -8.62       | 13.19      | 3        | Vertical  | 114         | 3.00       | -       | 28.20   | 3.99    | -       |
| PK   | 2.4322G   | 109.88         | Inf            | -Inf        | 77.65      | 3        | Vertical  | 114         | 3.00       | -       | 28.20   | 4.03    | -       |
| AV   | 2.4418G   | 100.44         | Inf            | -Inf        | 68.20      | 3        | Vertical  | 114         | 3.00       | -       | 28.20   | 4.04    | -       |
| PK   | 2.4854G   | 58.58          | 74.00          | -15.42      | 26.08      | 3        | Vertical  | 114         | 3.00       | -       | 28.41   | 4.09    | -       |
| AV   | 2.4838G   | 45.95          | 54.00          | -8.05       | 13.47      | 3        | Vertical  | 114         | 3.00       | -       | 28.40   | 4.08    | -       |

2.4-2.4835GHz\_802.11n\_HT20\_Nss1,(MCS0)\_1TX

2437MHz\_TX

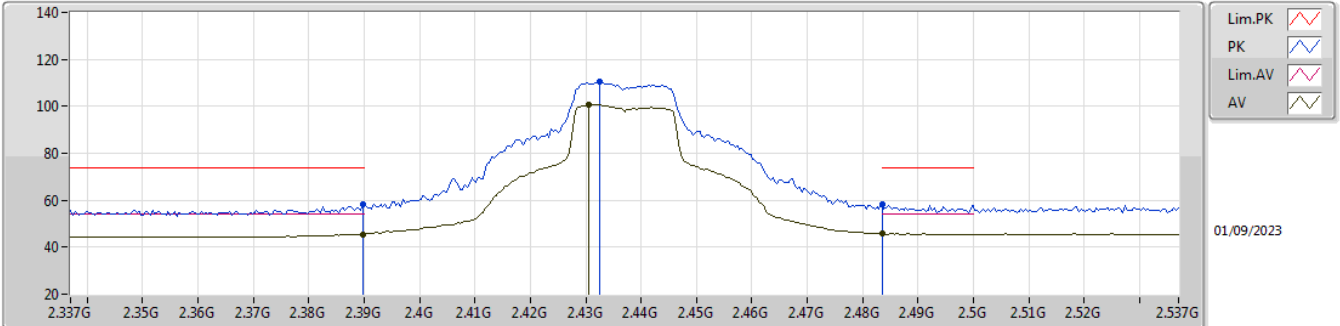

EUT\_Z\_1TX  
Setting 63  
03-E-R-7

| Type | Freq (Hz) | Level (dBuV/m) | Limit (dBuV/m) | Margin (dB) | Raw (dBuV) | Dist (m) | Condition  | Azimuth (°) | Height (m) | Comment | AF (dB) | CL (dB) | PA (dB) |
|------|-----------|----------------|----------------|-------------|------------|----------|------------|-------------|------------|---------|---------|---------|---------|
| PK   | 2.3898G   | 58.09          | 74.00          | -15.91      | 25.90      | 3        | Horizontal | 346         | 1.28       | -       | 28.20   | 3.99    | -       |
| AV   | 2.3898G   | 45.55          | 54.00          | -8.45       | 13.36      | 3        | Horizontal | 346         | 1.28       | -       | 28.20   | 3.99    | -       |
| PK   | 2.4326G   | 110.30         | Inf            | -Inf        | 78.07      | 3        | Horizontal | 346         | 1.28       | -       | 28.20   | 4.03    | -       |
| AV   | 2.4306G   | 100.66         | Inf            | -Inf        | 68.43      | 3        | Horizontal | 346         | 1.28       | -       | 28.20   | 4.03    | -       |
| PK   | 2.4835G   | 58.48          | 74.00          | -15.52      | 26.00      | 3        | Horizontal | 346         | 1.28       | -       | 28.40   | 4.08    | -       |
| AV   | 2.4835G   | 45.81          | 54.00          | -8.19       | 13.33      | 3        | Horizontal | 346         | 1.28       | -       | 28.40   | 4.08    | -       |

2.4-2.4835GHz\_802.11n\_HT20\_Nss1,(MCS0)\_1TX

2437MHz\_TX

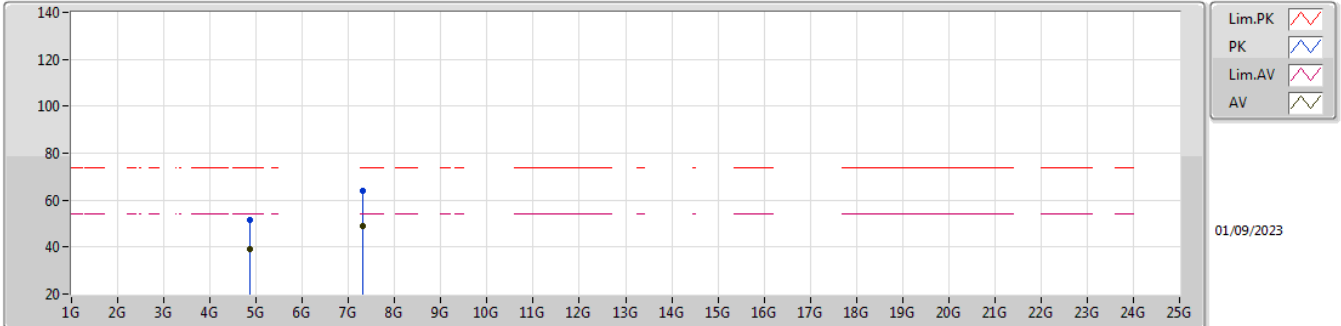

EUT\_Z\_1TX  
Setting 63  
03-E-R-7

| Type | Freq<br>(Hz) | Level<br>(dBuV/m) | Limit<br>(dBuV/m) | Margin<br>(dB) | Raw<br>(dBuV) | Dist<br>(m) | Condition | Azimuth<br>(°) | Height<br>(m) | Comment | AF<br>(dB) | CL<br>(dB) | PA<br>(dB) |
|------|--------------|-------------------|-------------------|----------------|---------------|-------------|-----------|----------------|---------------|---------|------------|------------|------------|
| PK   | 4.8742G      | 51.37             | 74.00             | -22.63         | 46.01         | 3           | Vertical  | 263            | 1.00          | -       | 33.55      | 6.54       | 34.73      |
| AV   | 4.8744G      | 39.21             | 54.00             | -14.79         | 33.85         | 3           | Vertical  | 263            | 1.00          | -       | 33.55      | 6.54       | 34.73      |
| PK   | 7.3139G      | 63.95             | 74.00             | -10.05         | 53.80         | 3           | Vertical  | 103            | 1.00          | -       | 36.83      | 8.70       | 35.38      |
| AV   | 7.3147G      | 49.15             | 54.00             | -4.85          | 39.00         | 3           | Vertical  | 103            | 1.00          | -       | 36.83      | 8.70       | 35.38      |

2.4-2.4835GHz\_802.11n\_HT20\_Nss1,(MCS0)\_1TX

2437MHz\_TX

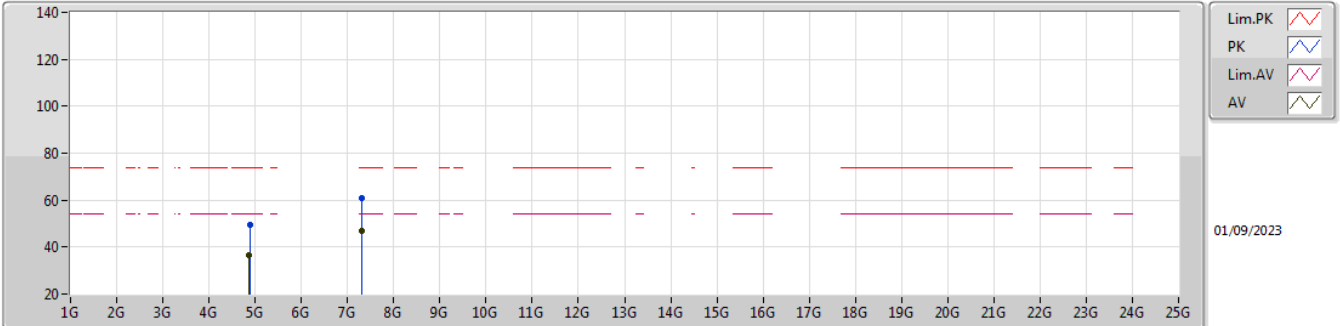

EUT\_Z\_1TX  
Setting 63  
03-E-R-7

| Type | Freq (Hz) | Level (dBuV/m) | Limit (dBuV/m) | Margin (dB) | Raw (dBuV) | Dist (m) | Condition  | Azimuth (°) | Height (m) | Comment | AF (dB) | CL (dB) | PA (dB) |
|------|-----------|----------------|----------------|-------------|------------|----------|------------|-------------|------------|---------|---------|---------|---------|
| PK   | 4.8909G   | 49.27          | 74.00          | -24.73      | 43.81      | 3        | Horizontal | 116         | 1.70       | -       | 33.65   | 6.55    | 34.74   |
| AV   | 4.8754G   | 36.80          | 54.00          | -17.20      | 31.44      | 3        | Horizontal | 116         | 1.70       | -       | 33.55   | 6.54    | 34.73   |
| PK   | 7.3187G   | 60.76          | 74.00          | -13.24      | 50.60      | 3        | Horizontal | 117         | 3.00       | -       | 36.84   | 8.70    | 35.38   |
| AV   | 7.3145G   | 46.83          | 54.00          | -7.17       | 36.68      | 3        | Horizontal | 117         | 3.00       | -       | 36.83   | 8.70    | 35.38   |

2.4-2.4835GHz\_802.11n\_HT20\_Nss1,(MCS0)\_1TX

2457MHz\_TX

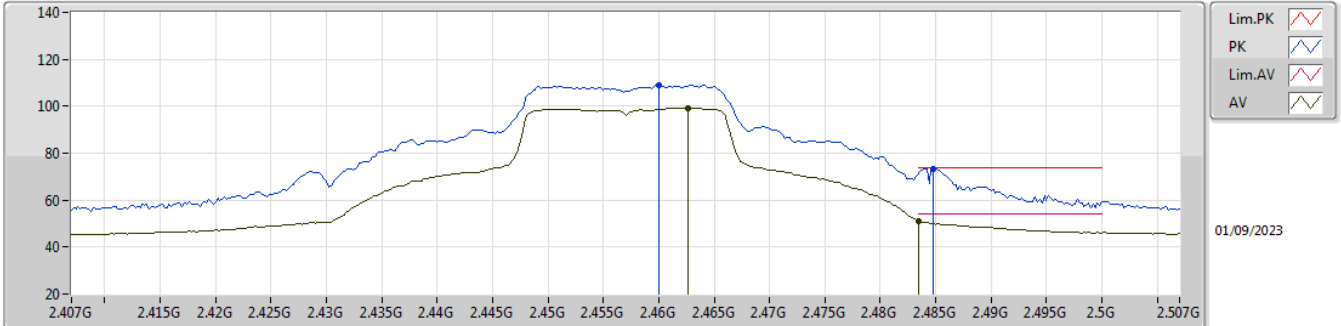

EUT\_Z\_1TX  
Setting 63  
03-C-W-4

| Type | Freq (Hz) | Level (dBuV/m) | Limit (dBuV/m) | Margin (dB) | Raw (dBuV) | Dist (m) | Condition | Azimuth (°) | Height (m) | Comment | AF (dB) | CL (dB) | PA (dB) |
|------|-----------|----------------|----------------|-------------|------------|----------|-----------|-------------|------------|---------|---------|---------|---------|
| PK   | 2.46G     | 109.16         | Inf            | -Inf        | 76.84      | 3        | Vertical  | 98          | 2.94       | -       | 28.26   | 4.06    | -       |
| AV   | 2.4626G   | 99.27          | Inf            | -Inf        | 66.93      | 3        | Vertical  | 98          | 2.94       | -       | 28.28   | 4.06    | -       |
| PK   | 2.4848G   | 73.31          | 74.00          | -0.69       | 40.82      | 3        | Vertical  | 98          | 2.94       | -       | 28.41   | 4.08    | -       |
| AV   | 2.4835G   | 51.03          | 54.00          | -2.97       | 18.55      | 3        | Vertical  | 98          | 2.94       | -       | 28.40   | 4.08    | -       |

2.4-2.4835GHz\_802.11n\_HT20\_Nss1,(MCS0)\_1TX

2457MHz\_TX

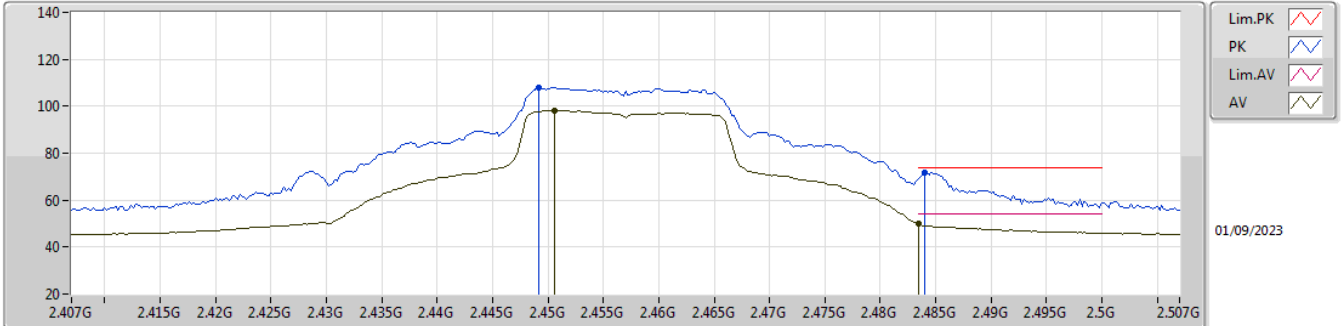

EUT\_Z\_1TX  
Setting 63  
03-C-W-4

| Type | Freq (Hz) | Level (dBuV/m) | Limit (dBuV/m) | Margin (dB) | Raw (dBuV) | Dist (m) | Condition  | Azimuth (°) | Height (m) | Comment | AF (dB) | CL (dB) | PA (dB) |
|------|-----------|----------------|----------------|-------------|------------|----------|------------|-------------|------------|---------|---------|---------|---------|
| PK   | 2.4492G   | 107.82         | Inf            | -Inf        | 75.57      | 3        | Horizontal | 355         | 1.00       | -       | 28.20   | 4.05    | -       |
| AV   | 2.4506G   | 98.27          | Inf            | -Inf        | 66.02      | 3        | Horizontal | 355         | 1.00       | -       | 28.20   | 4.05    | -       |
| PK   | 2.484G    | 71.50          | 74.00          | -2.50       | 39.02      | 3        | Horizontal | 355         | 1.00       | -       | 28.40   | 4.08    | -       |
| AV   | 2.4835G   | 49.80          | 54.00          | -4.20       | 17.32      | 3        | Horizontal | 355         | 1.00       | -       | 28.40   | 4.08    | -       |

2.4-2.4835GHz\_802.11n\_HT20\_Nss1,(MCS0)\_1TX

2462MHz\_TX

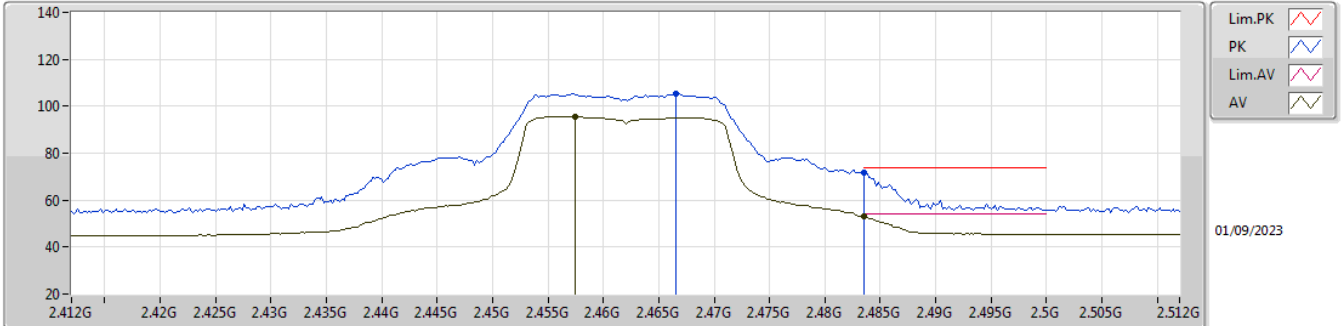

EUT\_Z\_1TX  
Setting 55  
03-E-W-4

| Type | Freq (Hz) | Level (dBuV/m) | Limit (dBuV/m) | Margin (dB) | Raw (dBuV) | Dist (m) | Condition | Azimuth (°) | Height (m) | Comment | AF (dB) | CL (dB) | PA (dB) |
|------|-----------|----------------|----------------|-------------|------------|----------|-----------|-------------|------------|---------|---------|---------|---------|
| PK   | 2.4666G   | 105.57         | Inf            | -Inf        | 73.20      | 3        | Vertical  | 40          | 1.65       | -       | 28.30   | 4.07    | -       |
| AV   | 2.4574G   | 95.60          | Inf            | -Inf        | 63.30      | 3        | Vertical  | 40          | 1.65       | -       | 28.24   | 4.06    | -       |
| PK   | 2.4835G   | 71.83          | 74.00          | -2.17       | 39.35      | 3        | Vertical  | 40          | 1.65       | -       | 28.40   | 4.08    | -       |
| AV   | 2.4835G   | 52.99          | 54.00          | -1.01       | 20.51      | 3        | Vertical  | 40          | 1.65       | -       | 28.40   | 4.08    | -       |

2.4-2.4835GHz\_802.11n\_HT20\_Nss1,(MCS0)\_1TX

2462MHz\_TX

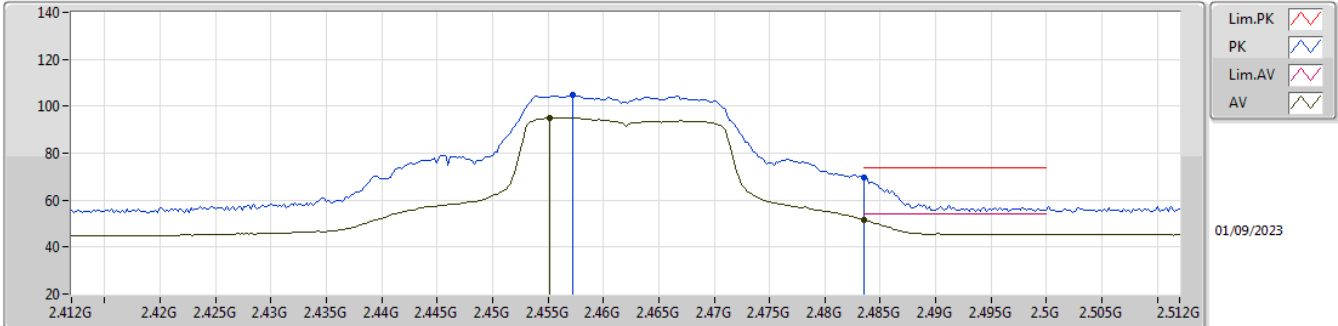

EUT\_Z\_1TX  
 Setting 55  
 03-E-W-4

| Type | Freq (Hz) | Level (dBuV/m) | Limit (dBuV/m) | Margin (dB) | Raw (dBuV) | Dist (m) | Condition  | Azimuth (°) | Height (m) | Comment | AF (dB) | CL (dB) | PA (dB) |
|------|-----------|----------------|----------------|-------------|------------|----------|------------|-------------|------------|---------|---------|---------|---------|
| PK   | 2.4572G   | 104.62         | Inf            | -Inf        | 72.32      | 3        | Horizontal | 356         | 1.00       | -       | 28.24   | 4.06    | -       |
| AV   | 2.4552G   | 95.14          | Inf            | -Inf        | 62.85      | 3        | Horizontal | 356         | 1.00       | -       | 28.23   | 4.06    | -       |
| PK   | 2.4835G   | 69.90          | 74.00          | -4.10       | 37.42      | 3        | Horizontal | 356         | 1.00       | -       | 28.40   | 4.08    | -       |
| AV   | 2.4835G   | 51.75          | 54.00          | -2.25       | 19.27      | 3        | Horizontal | 356         | 1.00       | -       | 28.40   | 4.08    | -       |



2.4-2.4835GHz\_802.11n\_HT20\_Nss1,(MCS0)\_1TX

2462MHz\_TX

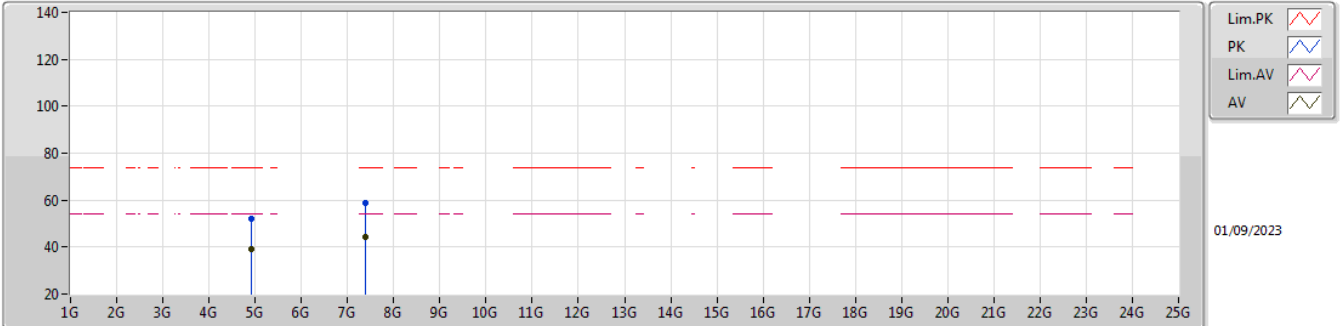

EUT\_Z\_1TX  
Setting 55  
03-E-W-4

| Type | Freq<br>(Hz) | Level<br>(dBuV/m) | Limit<br>(dBuV/m) | Margin<br>(dB) | Raw<br>(dBuV) | Dist<br>(m) | Condition | Azimuth<br>(°) | Height<br>(m) | Comment | AF<br>(dB) | CL<br>(dB) | PA<br>(dB) |
|------|--------------|-------------------|-------------------|----------------|---------------|-------------|-----------|----------------|---------------|---------|------------|------------|------------|
| PK   | 4.92052G     | 52.14             | 74.00             | -21.86         | 46.69         | 3           | Vertical  | 270            | 1.09          | -       | 33.66      | 6.56       | 34.77      |
| AV   | 4.92382G     | 38.91             | 54.00             | -15.09         | 33.47         | 3           | Vertical  | 270            | 1.09          | -       | 33.65      | 6.56       | 34.77      |
| PK   | 7.3803G      | 59.02             | 74.00             | -14.98         | 48.76         | 3           | Vertical  | 114            | 1.12          | -       | 36.90      | 8.70       | 35.34      |
| AV   | 7.38564G     | 44.32             | 54.00             | -9.68          | 34.06         | 3           | Vertical  | 114            | 1.12          | -       | 36.90      | 8.70       | 35.34      |

2.4-2.4835GHz\_802.11n\_HT20\_Nss1,(MCS0)\_1TX

2462MHz\_TX

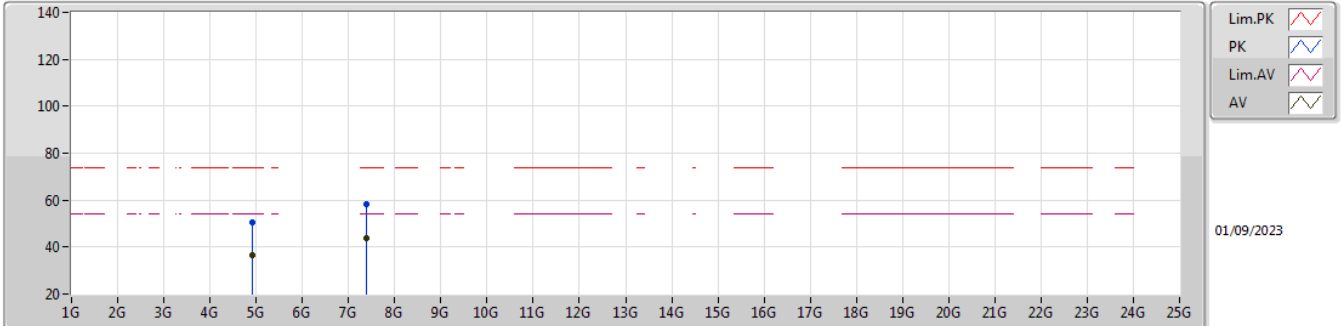

EUT\_Z\_1TX  
 Setting 55  
 03-E-W-4

| Type | Freq (Hz) | Level (dBuV/m) | Limit (dBuV/m) | Margin (dB) | Raw (dBuV) | Dist (m) | Condition  | Azimuth (°) | Height (m) | Comment | AF (dB) | CL (dB) | PA (dB) |
|------|-----------|----------------|----------------|-------------|------------|----------|------------|-------------|------------|---------|---------|---------|---------|
| PK   | 4.92688G  | 50.39          | 74.00          | -23.61      | 44.95      | 3        | Horizontal | 17          | 2.67       | -       | 33.65   | 6.56    | 34.77   |
| AV   | 4.92448G  | 36.45          | 54.00          | -17.55      | 31.01      | 3        | Horizontal | 17          | 2.67       | -       | 33.65   | 6.56    | 34.77   |
| PK   | 7.3875G   | 58.05          | 74.00          | -15.95      | 47.79      | 3        | Horizontal | 51          | 1.77       | -       | 36.90   | 8.70    | 35.34   |
| AV   | 7.3824G   | 43.66          | 54.00          | -10.34      | 33.40      | 3        | Horizontal | 51          | 1.77       | -       | 36.90   | 8.70    | 35.34   |

2.4-2.4835GHz\_802.11n\_HT40\_Nss1,(MCS0)\_1TX

2422MHz\_TX

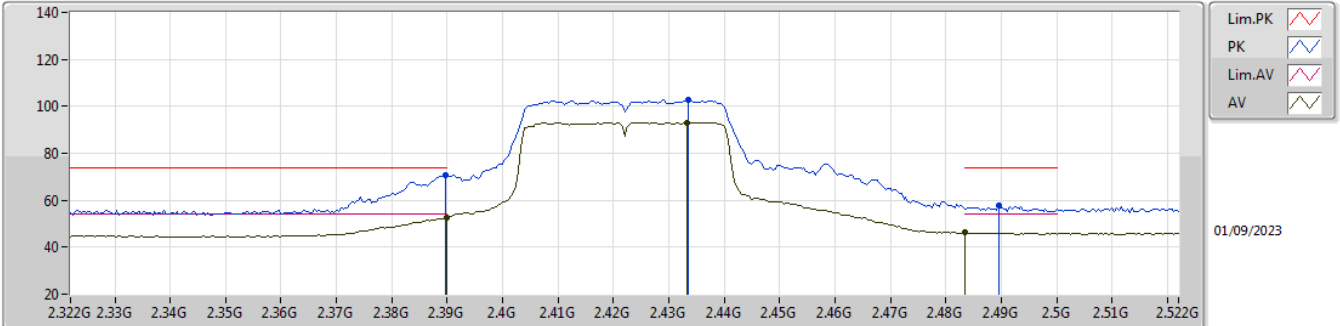

EUT\_Z\_1TX  
Setting 53  
03-C-W-4

| Type | Freq (Hz) | Level (dBuV/m) | Limit (dBuV/m) | Margin (dB) | Raw (dBuV) | Dist (m) | Condition | Azimuth (°) | Height (m) | Comment | AF (dB) | CL (dB) | PA (dB) |
|------|-----------|----------------|----------------|-------------|------------|----------|-----------|-------------|------------|---------|---------|---------|---------|
| PK   | 2.3896G   | 70.75          | 74.00          | -3.25       | 38.56      | 3        | Vertical  | 120         | 2.72       | -       | 28.20   | 3.99    | -       |
| AV   | 2.39G     | 52.55          | 54.00          | -1.45       | 20.36      | 3        | Vertical  | 120         | 2.72       | -       | 28.20   | 3.99    | -       |
| PK   | 2.4336G   | 102.80         | Inf            | -Inf        | 70.57      | 3        | Vertical  | 120         | 2.72       | -       | 28.20   | 4.03    | -       |
| AV   | 2.4332G   | 93.13          | Inf            | -Inf        | 60.90      | 3        | Vertical  | 120         | 2.72       | -       | 28.20   | 4.03    | -       |
| PK   | 2.4896G   | 57.91          | 74.00          | -16.09      | 25.38      | 3        | Vertical  | 120         | 2.72       | -       | 28.44   | 4.09    | -       |
| AV   | 2.4835G   | 46.15          | 54.00          | -7.85       | 13.67      | 3        | Vertical  | 120         | 2.72       | -       | 28.40   | 4.08    | -       |

2.4-2.4835GHz\_802.11n\_HT40\_Nss1,(MCS0)\_1TX

2422MHz\_TX

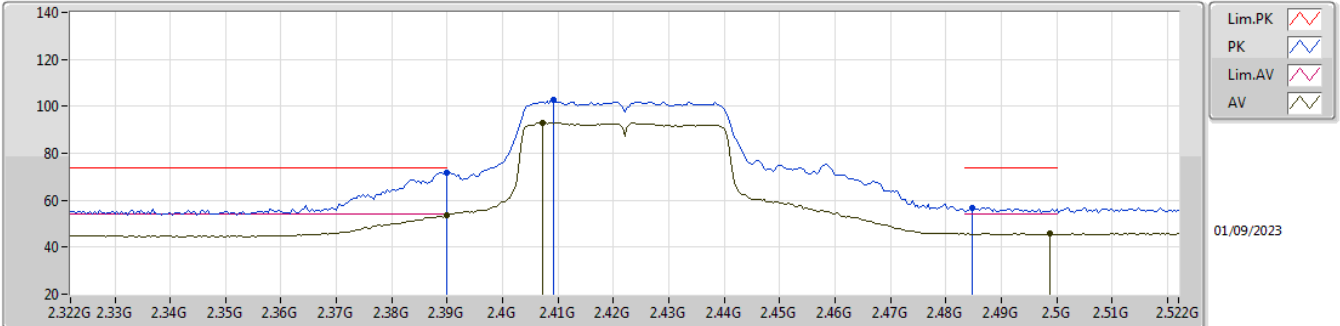

EUT\_Z\_1TX  
Setting 53  
03-C-W-4

| Type | Freq (Hz) | Level (dBuV/m) | Limit (dBuV/m) | Margin (dB) | Raw (dBuV) | Dist (m) | Condition  | Azimuth (°) | Height (m) | Comment | AF (dB) | CL (dB) | PA (dB) |
|------|-----------|----------------|----------------|-------------|------------|----------|------------|-------------|------------|---------|---------|---------|---------|
| PK   | 2.39G     | 71.86          | 74.00          | -2.14       | 39.67      | 3        | Horizontal | 344         | 1.00       | -       | 28.20   | 3.99    | -       |
| AV   | 2.39G     | 53.52          | 54.00          | -0.48       | 21.33      | 3        | Horizontal | 344         | 1.00       | -       | 28.20   | 3.99    | -       |
| PK   | 2.4092G   | 102.53         | Inf            | -Inf        | 70.32      | 3        | Horizontal | 344         | 1.00       | -       | 28.20   | 4.01    | -       |
| AV   | 2.4072G   | 93.04          | Inf            | -Inf        | 60.83      | 3        | Horizontal | 344         | 1.00       | -       | 28.20   | 4.01    | -       |
| PK   | 2.4848G   | 56.77          | 74.00          | -17.23      | 24.28      | 3        | Horizontal | 344         | 1.00       | -       | 28.41   | 4.08    | -       |
| AV   | 2.4988G   | 45.88          | 54.00          | -8.12       | 13.29      | 3        | Horizontal | 344         | 1.00       | -       | 28.49   | 4.10    | -       |

2.4-2.4835GHz\_802.11n\_HT40\_Nss1,(MCS0)\_1TX

2422MHz\_TX

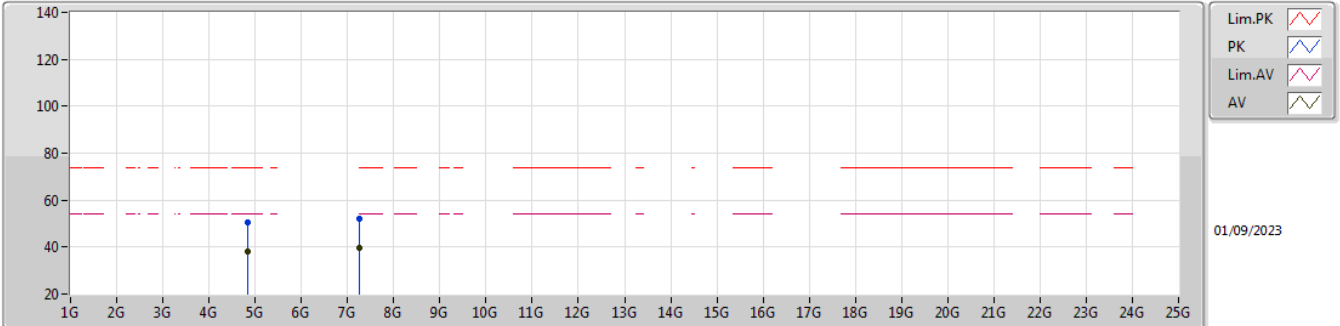

EUT\_Z\_1TX  
Setting 53  
03-C-W-4

| Type | Freq<br>(Hz) | Level<br>(dBuV/m) | Limit<br>(dBuV/m) | Margin<br>(dB) | Raw<br>(dBuV) | Dist<br>(m) | Condition | Azimuth<br>(°) | Height<br>(m) | Comment | AF<br>(dB) | CL<br>(dB) | PA<br>(dB) |
|------|--------------|-------------------|-------------------|----------------|---------------|-------------|-----------|----------------|---------------|---------|------------|------------|------------|
| PK   | 4.84526G     | 50.76             | 74.00             | -23.24         | 45.55         | 3           | Vertical  | 267            | 1.00          | -       | 33.40      | 6.52       | 34.71      |
| AV   | 4.84796G     | 38.19             | 54.00             | -15.81         | 32.98         | 3           | Vertical  | 267            | 1.00          | -       | 33.40      | 6.52       | 34.71      |
| PK   | 7.25154G     | 52.32             | 74.00             | -21.68         | 42.42         | 3           | Vertical  | 83             | 1.02          | -       | 36.61      | 8.70       | 35.41      |
| AV   | 7.25874G     | 39.79             | 54.00             | -14.21         | 29.87         | 3           | Vertical  | 83             | 1.02          | -       | 36.63      | 8.70       | 35.41      |

2.4-2.4835GHz\_802.11n\_HT40\_Nss1,(MCS0)\_1TX

2422MHz\_TX

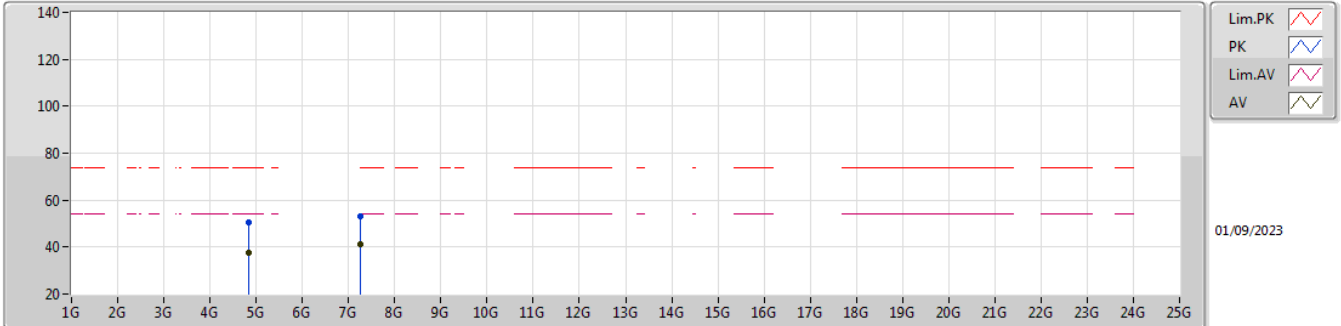

EUT\_Z\_1TX  
Setting 53  
03-C-W-4

| Type | Freq (Hz) | Level (dBuV/m) | Limit (dBuV/m) | Margin (dB) | Raw (dBuV) | Dist (m) | Condition  | Azimuth (°) | Height (m) | Comment | AF (dB) | CL (dB) | PA (dB) |
|------|-----------|----------------|----------------|-------------|------------|----------|------------|-------------|------------|---------|---------|---------|---------|
| PK   | 4.84016G  | 50.65          | 74.00          | -23.35      | 45.44      | 3        | Horizontal | 177         | 1.99       | -       | 33.40   | 6.52    | 34.71   |
| AV   | 4.84352G  | 37.76          | 54.00          | -16.24      | 32.55      | 3        | Horizontal | 177         | 1.99       | -       | 33.40   | 6.52    | 34.71   |
| PK   | 7.26456G  | 53.19          | 74.00          | -20.81      | 43.24      | 3        | Horizontal | 154         | 1.61       | -       | 36.66   | 8.70    | 35.41   |
| AV   | 7.26552G  | 41.19          | 54.00          | -12.81      | 31.24      | 3        | Horizontal | 154         | 1.61       | -       | 36.66   | 8.70    | 35.41   |

2.4-2.4835GHz\_802.11n\_HT40\_Nss1,(MCS0)\_1TX

2427MHz\_TX

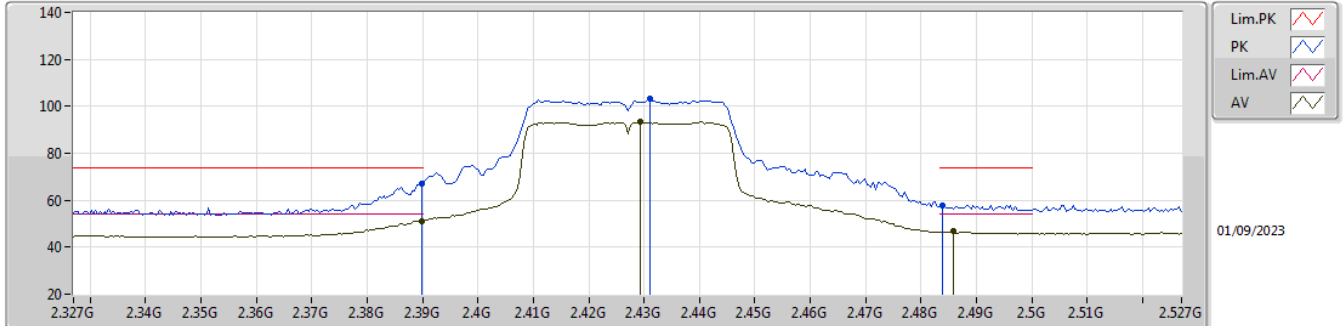

EUT\_Z\_1TX  
Setting 53  
03-C-R-7

| Type | Freq (Hz) | Level (dBuV/m) | Limit (dBuV/m) | Margin (dB) | Raw (dBuV) | Dist (m) | Condition | Azimuth (°) | Height (m) | Comment | AF (dB) | CL (dB) | PA (dB) |
|------|-----------|----------------|----------------|-------------|------------|----------|-----------|-------------|------------|---------|---------|---------|---------|
| PK   | 2.3898G   | 67.20          | 74.00          | -6.80       | 35.01      | 3        | Vertical  | 119         | 2.71       | -       | 28.20   | 3.99    | -       |
| AV   | 2.3898G   | 51.27          | 54.00          | -2.73       | 19.08      | 3        | Vertical  | 119         | 2.71       | -       | 28.20   | 3.99    | -       |
| PK   | 2.431G    | 103.14         | Inf            | -Inf        | 70.91      | 3        | Vertical  | 119         | 2.71       | -       | 28.20   | 4.03    | -       |
| AV   | 2.4294G   | 93.32          | Inf            | -Inf        | 61.09      | 3        | Vertical  | 119         | 2.71       | -       | 28.20   | 4.03    | -       |
| PK   | 2.4838G   | 57.91          | 74.00          | -16.09      | 25.43      | 3        | Vertical  | 119         | 2.71       | -       | 28.40   | 4.08    | -       |
| AV   | 2.4858G   | 46.70          | 54.00          | -7.30       | 14.20      | 3        | Vertical  | 119         | 2.71       | -       | 28.41   | 4.09    | -       |

2.4-2.4835GHz\_802.11n HT40\_Nss1,(MCS0)\_1TX

2427MHz\_TX

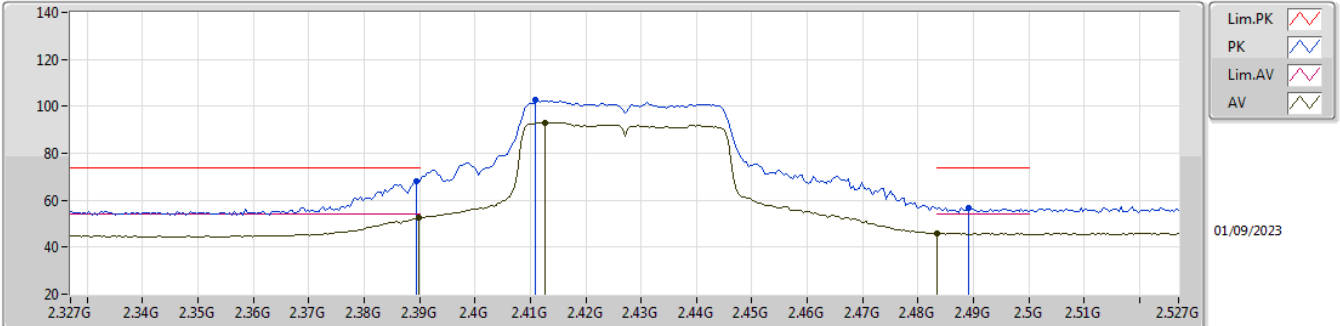

EUT\_Z\_1TX  
Setting 53  
03-C-R-7

| Type | Freq (Hz) | Level (dBuV/m) | Limit (dBuV/m) | Margin (dB) | Raw (dBuV) | Dist (m) | Condition  | Azimuth (°) | Height (m) | Comment | AF (dB) | CL (dB) | PA (dB) |
|------|-----------|----------------|----------------|-------------|------------|----------|------------|-------------|------------|---------|---------|---------|---------|
| PK   | 2.3894G   | 68.35          | 74.00          | -5.65       | 36.16      | 3        | Horizontal | 342         | 1.28       | -       | 28.20   | 3.99    | -       |
| AV   | 2.3898G   | 52.51          | 54.00          | -1.49       | 20.32      | 3        | Horizontal | 342         | 1.28       | -       | 28.20   | 3.99    | -       |
| PK   | 2.411G    | 102.87         | Inf            | -Inf        | 70.66      | 3        | Horizontal | 342         | 1.28       | -       | 28.20   | 4.01    | -       |
| AV   | 2.4126G   | 93.14          | Inf            | -Inf        | 60.93      | 3        | Horizontal | 342         | 1.28       | -       | 28.20   | 4.01    | -       |
| PK   | 2.489G    | 56.80          | 74.00          | -17.20      | 24.28      | 3        | Horizontal | 342         | 1.28       | -       | 28.43   | 4.09    | -       |
| AV   | 2.4835G   | 46.07          | 54.00          | -7.93       | 13.59      | 3        | Horizontal | 342         | 1.28       | -       | 28.40   | 4.08    | -       |



2.4-2.4835GHz\_802.11n\_HT40\_Nss1,(MCS0)\_1TX

2437MHz\_TX

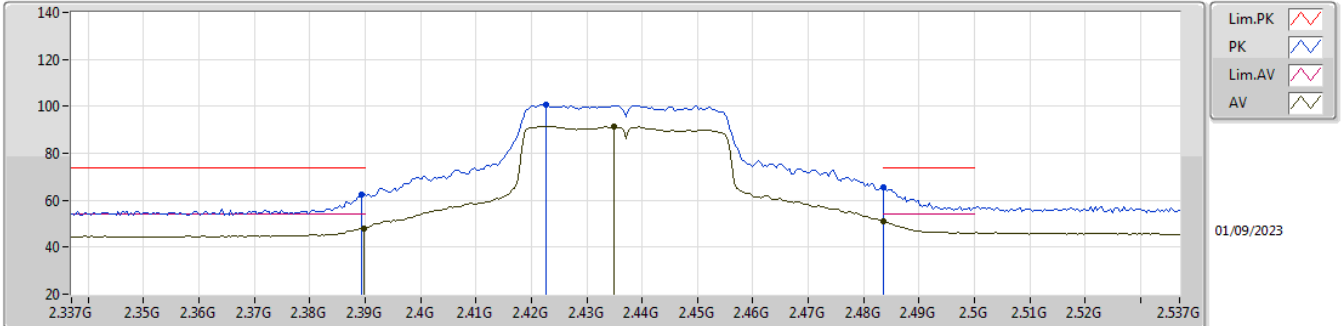

01/09/2023

EUT\_Z\_1TX  
Setting 56  
03-C-R-7

| Type | Freq (Hz) | Level (dBuV/m) | Limit (dBuV/m) | Margin (dB) | Raw (dBuV) | Dist (m) | Condition | Azimuth (°) | Height (m) | Comment | AF (dB) | CL (dB) | PA (dB) |
|------|-----------|----------------|----------------|-------------|------------|----------|-----------|-------------|------------|---------|---------|---------|---------|
| PK   | 2.3894G   | 62.67          | 74.00          | -11.33      | 30.48      | 3        | Vertical  | 117         | 2.41       | -       | 28.20   | 3.99    | -       |
| AV   | 2.3898G   | 48.16          | 54.00          | -5.84       | 15.97      | 3        | Vertical  | 117         | 2.41       | -       | 28.20   | 3.99    | -       |
| PK   | 2.4226G   | 100.75         | Inf            | -Inf        | 68.53      | 3        | Vertical  | 117         | 2.41       | -       | 28.20   | 4.02    | -       |
| AV   | 2.435G    | 91.45          | Inf            | -Inf        | 59.21      | 3        | Vertical  | 117         | 2.41       | -       | 28.20   | 4.04    | -       |
| PK   | 2.4835G   | 65.66          | 74.00          | -8.34       | 33.18      | 3        | Vertical  | 117         | 2.41       | -       | 28.40   | 4.08    | -       |
| AV   | 2.4835G   | 50.92          | 54.00          | -3.08       | 18.44      | 3        | Vertical  | 117         | 2.41       | -       | 28.40   | 4.08    | -       |

2.4-2.4835GHz\_802.11n\_HT40\_Nss1,(MCS0)\_1TX

2437MHz\_TX

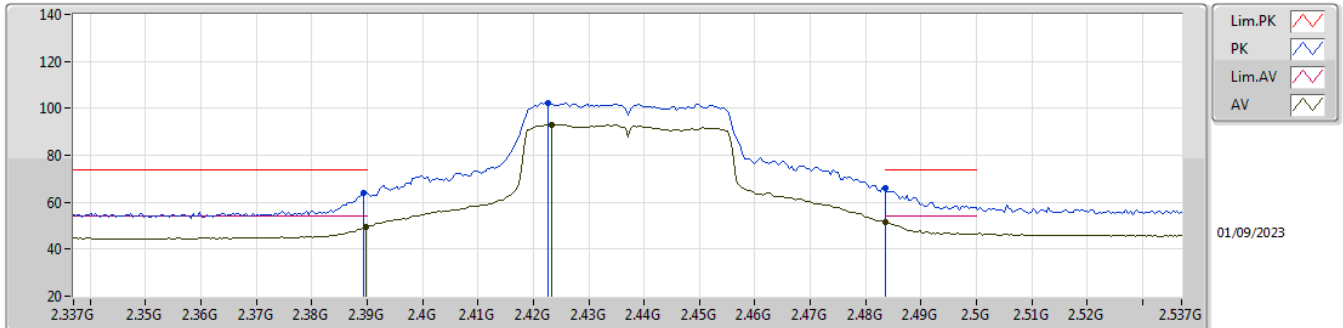

EUT\_Z\_1TX  
Setting 56  
03-C-R-7

| Type | Freq (Hz) | Level (dBuV/m) | Limit (dBuV/m) | Margin (dB) | Raw (dBuV) | Dist (m) | Condition  | Azimuth (°) | Height (m) | Comment | AF (dB) | CL (dB) | PA (dB) |
|------|-----------|----------------|----------------|-------------|------------|----------|------------|-------------|------------|---------|---------|---------|---------|
| PK   | 2.3894G   | 64.19          | 74.00          | -9.81       | 32.00      | 3        | Horizontal | 77          | 1.15       | -       | 28.20   | 3.99    | -       |
| AV   | 2.3898G   | 49.36          | 54.00          | -4.64       | 17.17      | 3        | Horizontal | 77          | 1.15       | -       | 28.20   | 3.99    | -       |
| PK   | 2.4226G   | 102.27         | Inf            | -Inf        | 70.05      | 3        | Horizontal | 77          | 1.15       | -       | 28.20   | 4.02    | -       |
| AV   | 2.4234G   | 93.05          | Inf            | -Inf        | 60.83      | 3        | Horizontal | 77          | 1.15       | -       | 28.20   | 4.02    | -       |
| PK   | 2.4835G   | 65.98          | 74.00          | -8.02       | 33.50      | 3        | Horizontal | 77          | 1.15       | -       | 28.40   | 4.08    | -       |
| AV   | 2.4835G   | 51.60          | 54.00          | -2.40       | 19.12      | 3        | Horizontal | 77          | 1.15       | -       | 28.40   | 4.08    | -       |

2.4-2.4835GHz\_802.11n\_HT40\_Nss1,(MCS0)\_1TX

2437MHz\_TX

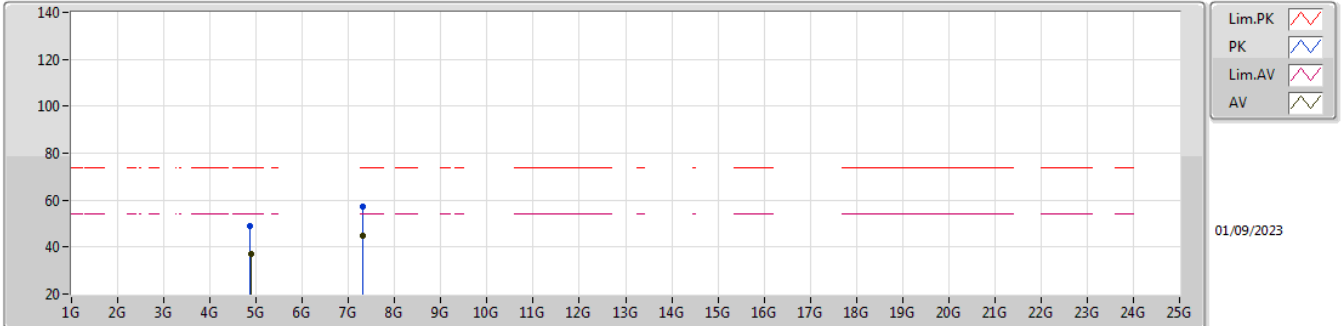

EUT\_Z\_1TX  
Setting 56  
03-C-R-7

| Type | Freq<br>(Hz) | Level<br>(dBuV/m) | Limit<br>(dBuV/m) | Margin<br>(dB) | Raw<br>(dBuV) | Dist<br>(m) | Condition | Azimuth<br>(°) | Height<br>(m) | Comment | AF<br>(dB) | CL<br>(dB) | PA<br>(dB) |
|------|--------------|-------------------|-------------------|----------------|---------------|-------------|-----------|----------------|---------------|---------|------------|------------|------------|
| PK   | 4.874G       | 48.76             | 74.00             | -25.24         | 43.41         | 3           | Vertical  | 144            | 1.78          | -       | 33.54      | 6.54       | 34.73      |
| AV   | 4.88912G     | 36.89             | 54.00             | -17.11         | 31.46         | 3           | Vertical  | 144            | 1.78          | -       | 33.63      | 6.54       | 34.74      |
| PK   | 7.32156G     | 57.00             | 74.00             | -17.00         | 46.83         | 3           | Vertical  | 115            | 1.00          | -       | 36.84      | 8.70       | 35.37      |
| AV   | 7.31424G     | 44.83             | 54.00             | -9.17          | 34.68         | 3           | Vertical  | 115            | 1.00          | -       | 36.83      | 8.70       | 35.38      |

2.4-2.4835GHz\_802.11n\_HT40\_Nss1,(MCS0)\_1TX

2437MHz\_TX

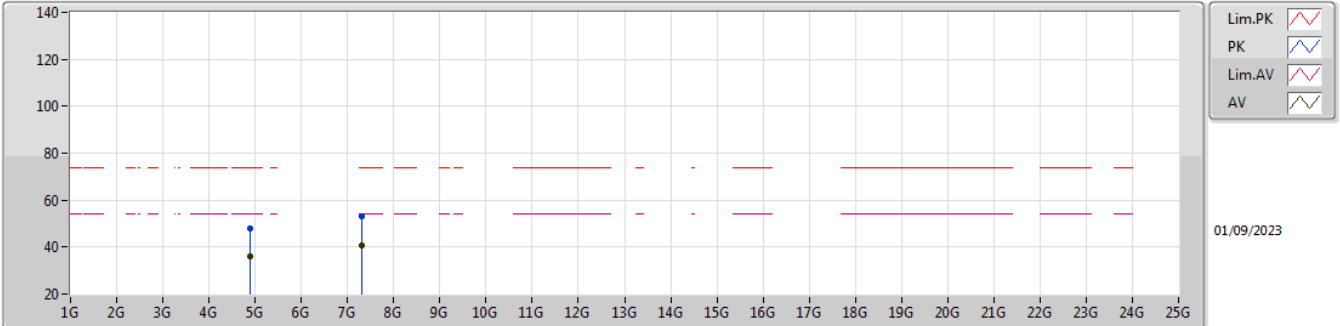

EUT\_Z\_1TX  
Setting 56  
03-C-R-7

| Type | Freq (Hz) | Level (dBuV/m) | Limit (dBuV/m) | Margin (dB) | Raw (dBuV) | Dist (m) | Condition  | Azimuth (°) | Height (m) | Comment | AF (dB) | CL (dB) | PA (dB) |
|------|-----------|----------------|----------------|-------------|------------|----------|------------|-------------|------------|---------|---------|---------|---------|
| PK   | 4.88084G  | 48.06          | 74.00          | -25.94      | 42.67      | 3        | Horizontal | 30          | 2.62       | -       | 33.59   | 6.54    | 34.74   |
| AV   | 4.88764G  | 35.99          | 54.00          | -18.01      | 30.56      | 3        | Horizontal | 30          | 2.62       | -       | 33.63   | 6.54    | 34.74   |
| PK   | 7.31904G  | 53.12          | 74.00          | -20.88      | 42.95      | 3        | Horizontal | 276         | 2.12       | -       | 36.84   | 8.70    | 35.37   |
| AV   | 7.317G    | 40.93          | 54.00          | -13.07      | 30.78      | 3        | Horizontal | 276         | 2.12       | -       | 36.83   | 8.70    | 35.38   |

2.4-2.4835GHz\_802.11n\_HT40\_Nss1,(MCS0)\_1TX

2447MHz\_TX

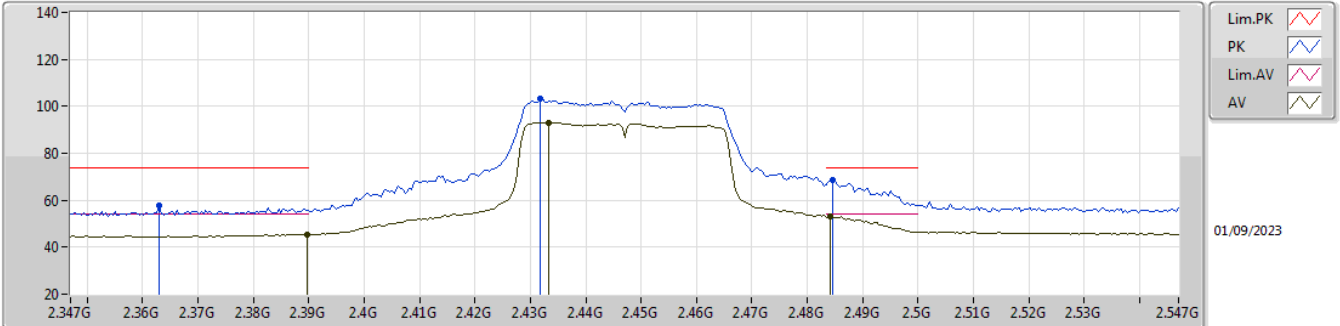

EUT\_Z\_1TX  
Setting 52  
03-C-R-7

| Type | Freq (Hz) | Level (dBuV/m) | Limit (dBuV/m) | Margin (dB) | Raw (dBuV) | Dist (m) | Condition | Azimuth (°) | Height (m) | Comment | AF (dB) | CL (dB) | PA (dB) |
|------|-----------|----------------|----------------|-------------|------------|----------|-----------|-------------|------------|---------|---------|---------|---------|
| PK   | 2.363G    | 57.80          | 74.00          | -16.20      | 25.64      | 3        | Vertical  | 120         | 2.73       | -       | 28.20   | 3.96    | -       |
| AV   | 2.3898G   | 45.33          | 54.00          | -8.67       | 13.14      | 3        | Vertical  | 120         | 2.73       | -       | 28.20   | 3.99    | -       |
| PK   | 2.4318G   | 103.34         | Inf            | -Inf        | 71.11      | 3        | Vertical  | 120         | 2.73       | -       | 28.20   | 4.03    | -       |
| AV   | 2.4334G   | 93.15          | Inf            | -Inf        | 60.92      | 3        | Vertical  | 120         | 2.73       | -       | 28.20   | 4.03    | -       |
| PK   | 2.4846G   | 68.75          | 74.00          | -5.25       | 36.26      | 3        | Vertical  | 120         | 2.73       | -       | 28.41   | 4.08    | -       |
| AV   | 2.4842G   | 53.02          | 54.00          | -0.98       | 20.53      | 3        | Vertical  | 120         | 2.73       | -       | 28.41   | 4.08    | -       |

2.4-2.4835GHz\_802.11n\_HT40\_Nss1,(MCS0)\_1TX

2447MHz\_TX

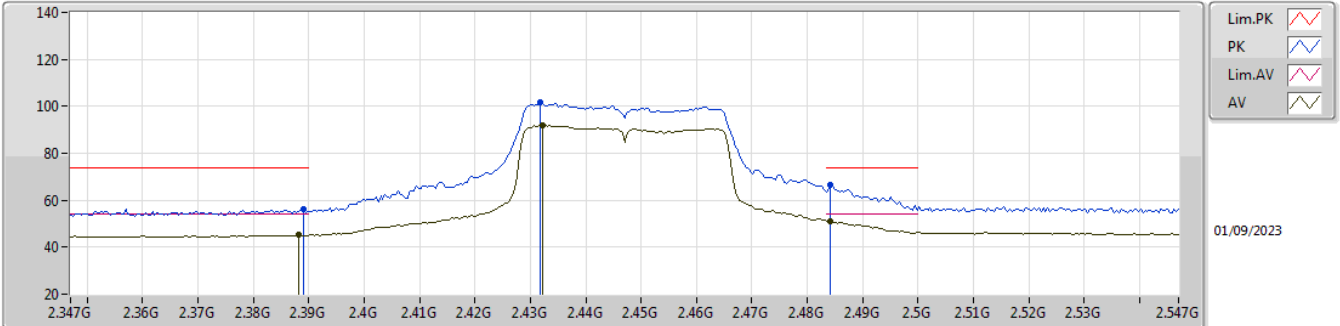

EUT\_Z\_1TX  
Setting 52  
03-C-R-7

| Type | Freq (Hz) | Level (dBuV/m) | Limit (dBuV/m) | Margin (dB) | Raw (dBuV) | Dist (m) | Condition  | Azimuth (°) | Height (m) | Comment | AF (dB) | CL (dB) | PA (dB) |
|------|-----------|----------------|----------------|-------------|------------|----------|------------|-------------|------------|---------|---------|---------|---------|
| PK   | 2.389G    | 56.41          | 74.00          | -17.59      | 24.22      | 3        | Horizontal | 76          | 1.18       | -       | 28.20   | 3.99    | -       |
| AV   | 2.3882G   | 45.09          | 54.00          | -8.91       | 12.90      | 3        | Horizontal | 76          | 1.18       | -       | 28.20   | 3.99    | -       |
| PK   | 2.4318G   | 101.95         | Inf            | -Inf        | 69.72      | 3        | Horizontal | 76          | 1.18       | -       | 28.20   | 4.03    | -       |
| AV   | 2.4322G   | 91.84          | Inf            | -Inf        | 59.61      | 3        | Horizontal | 76          | 1.18       | -       | 28.20   | 4.03    | -       |
| PK   | 2.4842G   | 66.71          | 74.00          | -7.29       | 34.22      | 3        | Horizontal | 76          | 1.18       | -       | 28.41   | 4.08    | -       |
| AV   | 2.4842G   | 51.24          | 54.00          | -2.76       | 18.75      | 3        | Horizontal | 76          | 1.18       | -       | 28.41   | 4.08    | -       |

2.4-2.4835GHz\_802.11n\_HT40\_Nss1,(MCS0)\_1TX

2452MHz\_TX

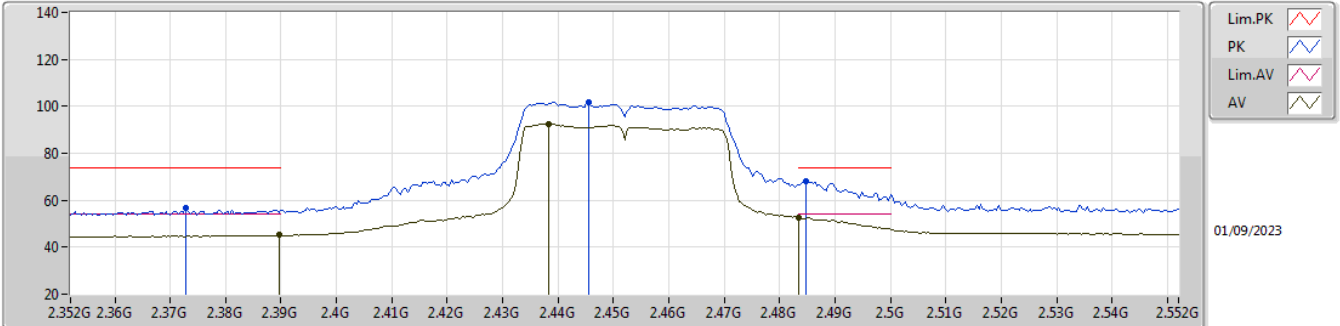

EUT\_Z\_1TX  
Setting 51  
03-C-R-7

| Type | Freq (Hz) | Level (dBuV/m) | Limit (dBuV/m) | Margin (dB) | Raw (dBuV) | Dist (m) | Condition | Azimuth (°) | Height (m) | Comment | AF (dB) | CL (dB) | PA (dB) |
|------|-----------|----------------|----------------|-------------|------------|----------|-----------|-------------|------------|---------|---------|---------|---------|
| PK   | 2.3728G   | 56.78          | 74.00          | -17.22      | 24.61      | 3        | Vertical  | 122         | 2.72       | -       | 28.20   | 3.97    | -       |
| AV   | 2.3896G   | 45.17          | 54.00          | -8.83       | 12.98      | 3        | Vertical  | 122         | 2.72       | -       | 28.20   | 3.99    | -       |
| PK   | 2.4456G   | 101.96         | Inf            | -Inf        | 69.71      | 3        | Vertical  | 122         | 2.72       | -       | 28.20   | 4.05    | -       |
| AV   | 2.4384G   | 92.36          | Inf            | -Inf        | 60.12      | 3        | Vertical  | 122         | 2.72       | -       | 28.20   | 4.04    | -       |
| PK   | 2.4848G   | 67.94          | 74.00          | -6.06       | 35.45      | 3        | Vertical  | 122         | 2.72       | -       | 28.41   | 4.08    | -       |
| AV   | 2.4835G   | 52.57          | 54.00          | -1.43       | 20.09      | 3        | Vertical  | 122         | 2.72       | -       | 28.40   | 4.08    | -       |

2.4-2.4835GHz\_802.11n\_HT40\_Nss1,(MCS0)\_1TX

2452MHz\_TX

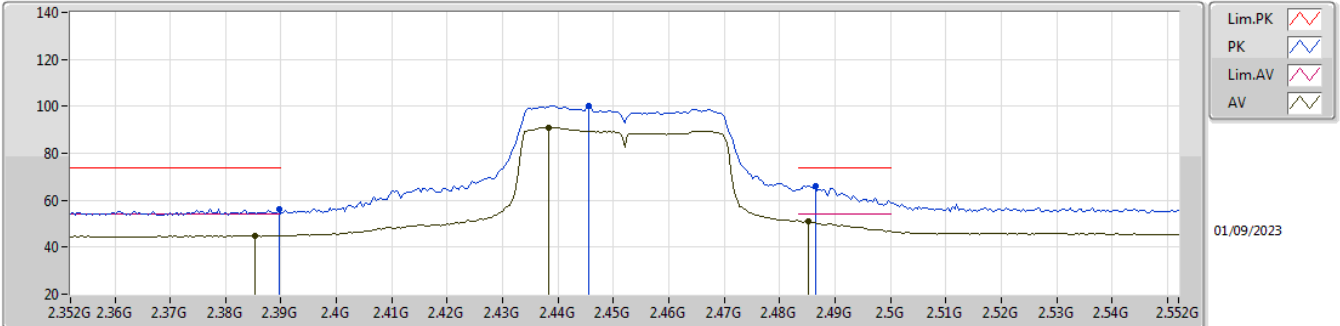

EUT\_Z\_1TX  
Setting 51  
03-C-R-7

| Type | Freq (Hz) | Level (dBuV/m) | Limit (dBuV/m) | Margin (dB) | Raw (dBuV) | Dist (m) | Condition  | Azimuth (°) | Height (m) | Comment | AF (dB) | CL (dB) | PA (dB) |
|------|-----------|----------------|----------------|-------------|------------|----------|------------|-------------|------------|---------|---------|---------|---------|
| PK   | 2.3896G   | 56.38          | 74.00          | -17.62      | 24.19      | 3        | Horizontal | 77          | 1.39       | -       | 28.20   | 3.99    | -       |
| AV   | 2.3852G   | 45.00          | 54.00          | -9.00       | 12.81      | 3        | Horizontal | 77          | 1.39       | -       | 28.20   | 3.99    | -       |
| PK   | 2.4456G   | 100.18         | Inf            | -Inf        | 67.93      | 3        | Horizontal | 77          | 1.39       | -       | 28.20   | 4.05    | -       |
| AV   | 2.4384G   | 91.03          | Inf            | -Inf        | 58.79      | 3        | Horizontal | 77          | 1.39       | -       | 28.20   | 4.04    | -       |
| PK   | 2.4864G   | 65.98          | 74.00          | -8.02       | 33.47      | 3        | Horizontal | 77          | 1.39       | -       | 28.42   | 4.09    | -       |
| AV   | 2.4852G   | 51.22          | 54.00          | -2.78       | 18.72      | 3        | Horizontal | 77          | 1.39       | -       | 28.41   | 4.09    | -       |



2.4-2.4835GHz\_802.11n\_HT40\_Nss1,(MCS0)\_1TX

2452MHz\_TX

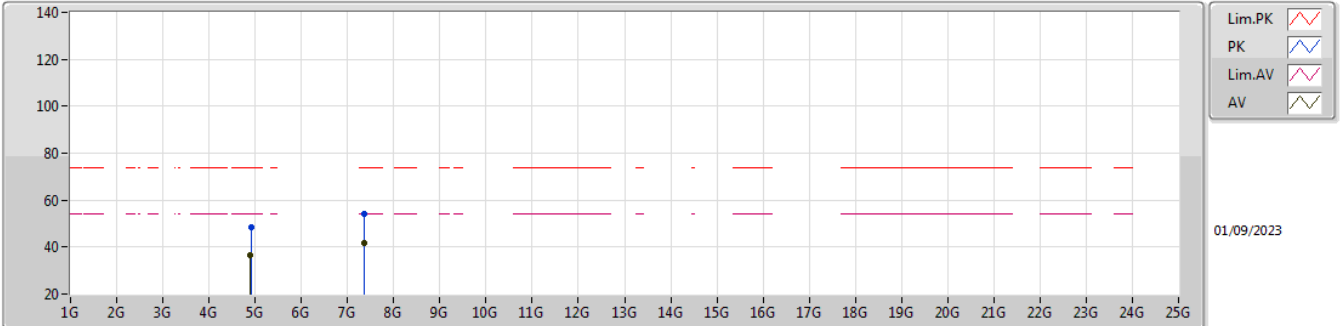

EUT\_Z\_1TX  
Setting 51  
03-C-R-7

| Type | Freq (Hz) | Level (dBuV/m) | Limit (dBuV/m) | Margin (dB) | Raw (dBuV) | Dist (m) | Condition | Azimuth (°) | Height (m) | Comment | AF (dB) | CL (dB) | PA (dB) |
|------|-----------|----------------|----------------|-------------|------------|----------|-----------|-------------|------------|---------|---------|---------|---------|
| PK   | 4.9112G   | 48.70          | 74.00          | -25.30      | 43.22      | 3        | Vertical  | 296         | 2.44       | -       | 33.68   | 6.56    | 34.76   |
| AV   | 4.89616G  | 36.52          | 54.00          | -17.48      | 31.04      | 3        | Vertical  | 296         | 2.44       | -       | 33.68   | 6.55    | 34.75   |
| PK   | 7.34992G  | 54.30          | 74.00          | -19.70      | 44.06      | 3        | Vertical  | 113         | 1.03       | -       | 36.90   | 8.70    | 35.36   |
| AV   | 7.36208G  | 41.70          | 54.00          | -12.30      | 31.45      | 3        | Vertical  | 113         | 1.03       | -       | 36.90   | 8.70    | 35.35   |

2.4-2.4835GHz\_802.11n\_HT40\_Nss1,(MCS0)\_1TX

2452MHz\_TX

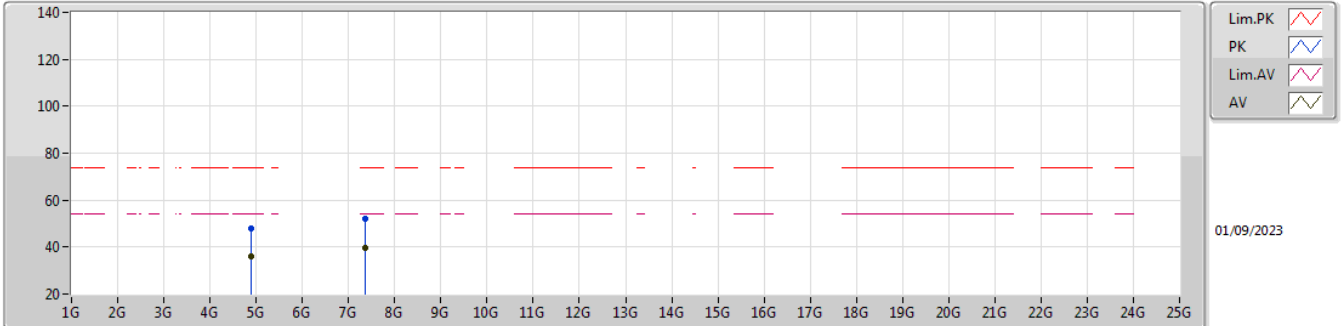

EUT\_Z\_1TX  
Setting 51  
03-C-R-7

| Type | Freq (Hz) | Level (dBuV/m) | Limit (dBuV/m) | Margin (dB) | Raw (dBuV) | Dist (m) | Condition  | Azimuth (°) | Height (m) | Comment | AF (dB) | CL (dB) | PA (dB) |
|------|-----------|----------------|----------------|-------------|------------|----------|------------|-------------|------------|---------|---------|---------|---------|
| PK   | 4.8888G   | 48.07          | 74.00          | -25.93      | 42.64      | 3        | Horizontal | 205         | 1.20       | -       | 33.63   | 6.54    | 34.74   |
| AV   | 4.8868G   | 36.10          | 54.00          | -17.90      | 30.68      | 3        | Horizontal | 205         | 1.20       | -       | 33.62   | 6.54    | 34.74   |
| PK   | 7.3552G   | 51.87          | 74.00          | -22.13      | 41.62      | 3        | Horizontal | 119         | 1.94       | -       | 36.90   | 8.70    | 35.35   |
| AV   | 7.35672G  | 39.78          | 54.00          | -14.22      | 29.53      | 3        | Horizontal | 119         | 1.94       | -       | 36.90   | 8.70    | 35.35   |