



FCC LISTED, REGISTRATION
 NUMBER: 2764.01

ISED LISTED REGISTRATION
 NUMBER: 23595-1

Test report No:
 2323ERM.004

Test report

FCC Rules and Regulations CFR 47, Part 15, Subpart B (10-1-18 Edition) &
 ICES-003 ISSUE 6 – Update April (2017)

Identification of item tested	WE866C3-P (Module)
Trademark	Telit
Model and /or type reference	WE866C3-P
Other identification of the product	FCC ID: RI7WE866C3 IC ID: 5131A-WE866C3
Features	BT BR/EDR/LE 4.2 + Wifi a/b/g/n/ac (wave 1=> Max BW= 80 MHz)
Manufacturer	TELIT COMMUNICATIONS S.P.A Viale Stazione di Prosecco 5/b, Trieste, Italy, 34010
Test method requested, standard	FCC Rules and Regulations CFR 47, Part 15, Subpart B (10-1-18 Edition) ICES-003 ISSUE 6 – Update April (2017)
Summary	IN COMPLIANCE
Approved by (name / position & signature)	Domingo Galvez EMC&RF Lab Manager
Date of issue	2019-02-19
Report template No	FDT08_21

Index

Competences and guarantees.....	3
General conditions	3
Uncertainty.....	3
Data provided by the client	4
Usage of samples	4
Test sample description	5
Identification of the client	6
Testing period and place.....	6
Document history	6
Environmental conditions	7
Remarks and comments	7
Testing verdicts.....	8
List of equipment used during the test.....	8
Appendix A: Test results	9

Competences and guarantees

DEKRA Certification Inc. is a testing laboratory accredited by A2LA (The American Association for Laboratory Accreditation), to perform the tests indicated in the Certificate 2764.01

DEKRA Certification Inc. is a testing laboratory competent to carry out the tests described in this report.

In order to assure the traceability to other national and international laboratories, DEKRA Certification Inc. has a calibration and maintenance program for its measurement equipment.

DEKRA Certification Inc. guarantees the reliability of the data presented in this report, which is the result of the measurements and the tests performed to the item under test on the date and under the conditions stated on the report and, it is based on the knowledge and technical facilities available at DEKRA Certification at the time of performance of the test.

DEKRA Certification Inc. is liable to the client for the maintenance of the confidentiality of all information related to the item under test and the results of the test.

The results presented in this Test Report apply only to the particular item under test established in this document.

IMPORTANT: No parts of this report may be reproduced or quoted out of context, in any form or by any means, except in full, without the previous written permission of DEKRA Certification Inc.

General conditions

1. This report is only referred to the item that has undergone the test.
2. This report does not constitute or imply on its own an approval of the product by the Certification Bodies or competent Authorities.
3. This document is only valid if complete; no partial reproduction can be made without previous written permission of DEKRA Certification Inc.
4. This test report cannot be used partially or in full for publicity and/or promotional purposes without previous written permission of DEKRA Certification Inc. and the Accreditation Bodies.

Uncertainty

Uncertainty (factor $k=2$) was calculated according to the DEKRA Certification internal document PODT000.

	Frequency (MHz)	U(k=2)	Units
Conducted emission	0,009 - 30	2.69	dB
Radiated emission	30-180	3.82	dB
	180-1000	2.61	dB
	1000-18000	2.92	dB
	18000-40000	2.15	dB

Data provided by the client

Companion module, supporting Wi-Fi 802.11 a/b/g/n/ac (wave 1) and BT (BR/EDR/LE(4.2)). Single RF antenna port for both technologies Wifi and BT. SDIO and HCI I/F, respectively for Wi-Fi and BT control. Module is controlled via a host Telit module, LE920A4 or LE910C1

DEKRA declines any responsibility with respect to the information provided by the client and that may affect the validity of results.

Usage of samples

Samples undergoing test have been selected by: The client.

Sample S/01 is composed of the following elements:

Control N°	Description	Model	Serial N°	Date of reception
2323.19	Telit Sample Cradle with Power Supply Cable	CS1742E	CS1742E-A 18000361	10/3/2018
2323.20	WE866C3-P (module)	WE866C3-P	1868A-A38927180014	10/3/2018
2323.22	Antenna Dual Band	-	1RR0100174TLB	10/3/2018

Sample S/01 was used in following testing: Radiated Emission

Test sample description

Ports..... :	Port name and description		Cable					
			Specified length [m]	Attached during test		Shielded		
	WIFI/BT RF port		0.1	<input checked="" type="checkbox"/>		<input type="checkbox"/>		
				<input type="checkbox"/>		<input type="checkbox"/>		
				<input type="checkbox"/>		<input type="checkbox"/>		
Supplementary information to the ports..... :								
Rated power supply	Voltage and Frequency			Reference poles				
				L1	L2	L3	N	PE
	<input type="checkbox"/>	AC: 230Vac / 50Hz.		<input type="checkbox"/>	<input type="checkbox"/>	<input type="checkbox"/>	<input type="checkbox"/>	<input type="checkbox"/>
	<input type="checkbox"/>	AC:		<input type="checkbox"/>	<input type="checkbox"/>	<input type="checkbox"/>	<input type="checkbox"/>	<input type="checkbox"/>
	<input checked="" type="checkbox"/>	DC:3.8V (internal DCDC converter supplying the WE866C3-P module with regulated voltage = 3.3V)						
Rated Power	18 dBm max							
Clock frequencies	48MHz							
Other parameters..... :	No Data provided							
Software version	LE910_25.20.000-B010_CUST_012-c4_perf_TF							
Hardware version..... :	CS1929a-A							
Dimensions in cm (L x W x D)	15x13mm.							
Mounting position..... :	<input type="checkbox"/>	Table top equipment						
	<input checked="" type="checkbox"/>	Wall/Ceiling mounted equipment						
	<input type="checkbox"/>	Floor standing equipment						
	<input type="checkbox"/>	Hand-held equipment						
	<input type="checkbox"/>	Other:						
Modules/parts	Module/parts of test item		Type		Manufacturer			
	No Data provided							
Accessories (not part of the test item)	Description		Type			Manufacturer		
Documents as provided by the applicant..... :	Description		File name			Issue date		
	Equipment declaration data		FDT30_14 Declaration Equipment Data			2018/9/24		

Copy of marking plate:



Identification of the client

TELIT COMMUNICATIONS S.P.A
Viale Stazione di Prosecco 5/b, Trieste, Italy, 34010

Testing period and place

Test Location	DEKRA Certification, Inc
Date (start)	2018-10-04
Date (finish)	2019-02-11

Document history

Report number	Date	Description
2323ERM.005	2019-02-15	First release

Environmental conditions

In the control chamber, the following limits were not exceeded during the test:

Temperature	Min. = 15 °C Max. = 35 °C
Relative humidity	Min. = 30 % Max. = 75 %
Air pressure	Min. = 860 mbar Max. = 1060 mbar

In the semianechoic chamber, the following limits were not exceeded during the test.

Temperature	Min. = 15 °C Max. = 35 °C
Relative humidity	Min. = 30 % Max. = 75 %
Air pressure	Min. = 860 mbar Max. = 1060 mbar

In the chamber for conducted measurements, the following limits were not exceeded during the test:

Temperature	Min. = 15 °C Max. = 35 °C
Relative humidity	Min. = 30 % Max. = 60 %
Air pressure	Min. = 860 mbar Max. = 1060 mbar

Remarks and comments

The tests have been performed by the technical personnel: Koji Nishimoto.

Testing verdicts

Not applicable :	N/A
Pass :	P
Fail :	F
Not measured :	N/M

Summary

Emission Test			
Report Section	Requirement – Test case	Verdict	Remark
A.1.	Radiated emission electromagnetic field test (30 MHz – 1000 MHz)	P	N/A
A.1.	Radiated emission electromagnetic field test (1 GHz – 18 GHz)	P	Refer 1
A.1.	Radiated emission electromagnetic field test (18 GHz – 26 GHz)	P	Refer 1
-.	Conducted emission test (150 kHz to 30 MHz)	N/A	Refer 2
Supplementary information and remarks: <ol style="list-style-type: none"> As per standard 47 CFR §15.33 due to the highest frequency generated or used in the device is above 1000MHz the upper frequency of measurement range is up to 5th harmonic of the highest frequency or 40GHz, whichever is lower. DUT is DC powered. 			

List of equipment used during the test

CONTROL NUMBER	DESCRIPTION	MANUFACTURER	MODEL	LAST CALIBRATION	NEXT CALIBRATION
0980	Preamplifier	BONN ELEKTRONIK	BLNA 0360-01N	2017/05	2019/05
0981	Preamplifier	BONN ELEKTRONIK	BLMA 0118-2A	2017/05	2019/05
0982	Preamplifier	BONN ELEKTRONIK	BLMA1840-1M	2017/05	2019/05
0997	LISN	NARDA	PMM L3-32	2017/03	2019/03
1010	EMI Test Receiver	ROHDE & SCHWARZ	ESR7	2017/03	2019/03
1012	EMI Test Receiver	ROHDE & SCHWARZ	ESR26	2017/03	2019/03
1017	EMC measurement software	ROHDE & SCHWARZ	EMC32 V9.01	---	---
1039	Signal Analyser	ROHDE & SCHWARZ	FSV40	2017/03	2019/03
1055	Horn Antenna	ETS LINDGREN	3116C	2016/12	2019/12
1058	Horn Antenna	ETS LINDGREN	3115	2017/03	2020/03
1065	Biconilog Antenna	ETS LINDGREN	3142E	2017/03	2020/03
1073	Pulse Limiter	NARDA	PMM PL01	2017/06	2019/06

Appendix A: Test results

Appendix A Content

DESCRIPTION OF THE OPERATION MODES	11
A.1.RADIATED EMISSION. ELECTROMAGNETIC FIELD TEST	12

DESCRIPTION OF THE OPERATION MODES

The operation modes described in this paragraph constitute a functionality of the sample under test for itself. Every operation mode takes failure criteria for the immunity test that they were applying to it and a monitoring to guarantee performance of the same ones.

The operation modes used by the samples to which the present report refers, are shown in the following table:

OPERATION MODE	DESCRIPTION
OM#01*	EUT ON. Idle mode (Wifi + Bluetooth). Power supply 3.8 Vdc

*Worst configurations detected

A.1.RADIATED EMISSION. ELECTROMAGNETIC FIELD TEST

LIMITS:	Product standard:	FCC CFR 47, Part 15, Subpart B (10-1-18 Edition), Secs. 15.109 & ICES-003 Issue 6 – Update April (2017)
	Test standard:	FCC CFR 47, Part 15, Subpart B (10-1-18 Edition), Secs. 15.109 & ICES-003 Issue 6 – Update April (2017); ANSI C63.4 (2014)

Limits of interference Class B

The applied limit for radiated emissions, 3 m distance, according with the requirements of FCC Rules and Regulations 47 CFR Part 15, Subpart B (10-01-18 Edition), Secs. 15.109 & ICES-003 Issue 6 – Update April (2017) in the frequency range 30 MHz to 40 GHz for class B equipment.

Frequency range (MHz)	QP Limit for 3 m	
	(μ V/m)	(dB μ V/m)
30 to 88	100	40
88 to 216	150	43.5
216 to 960	200	46
Above 960	500	54

Frequency range (MHz)	AVG Limit for 3 m		PK Limit for 3 m (1)
	(μ V/m)	(dB μ V/m)	(dB μ V/m)
Above 1000	500	54	74

- (1) Frequencies above 1 GHz, the limit on peak radio frequency emissions is 20 dB above the maximum permitted average emission limit applicable to the equipment under test, as per §15.35(b)

TEST SETUP

All radiated tests were performed in a semi-anechoic chamber. The measurement antenna is situated at a distance of 3 m for the frequency range 30-1000 MHz (Bilog antenna) and frequency range 1-18 GHz (Double ridge horn antennas).

For radiated emissions in the range 18-40 GHz (Double ridge horn antennas) that is performed at a distance closer than the specified distance, an inverse proportionality factor of 20 dB per decade is used to normalize the measured data for determining compliance.

The equipment under test was set up on a non-conductive platform above the ground plane and the situation and orientation was varied to find the maximum radiated emission. It was also rotated 360° and the antenna height was varied from 1 to 4 meters to find the maximum radiated emission.

Measurements were made in both horizontal and vertical planes of polarization.

The field strength is calculated by adding correction factor to the measured level from the spectrum analyzer. This correction factor includes antenna factor, cable loss and pre-amplifiers gain.

TEST SETUP (Cont.)

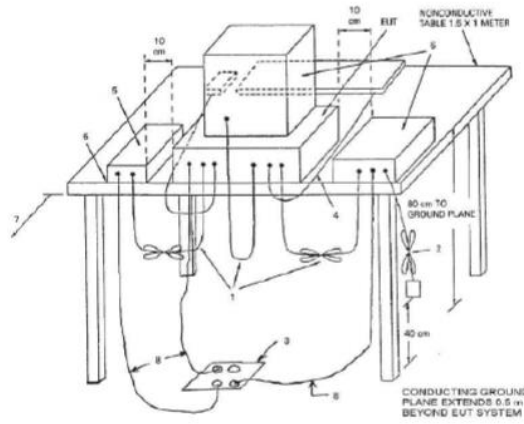
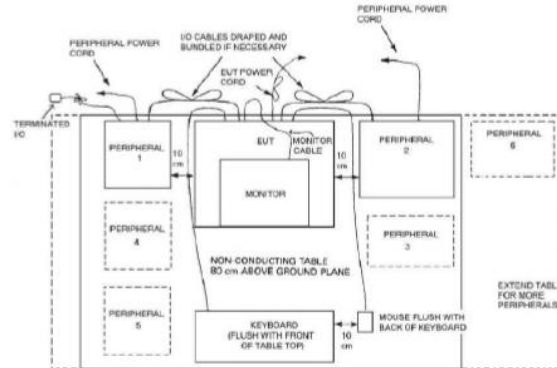

TESTED SAMPLES:

S/01

TESTED OPERATION MODES:

OM#01

TEST RESULTS:

CRmmnxx: CR, Radiation Condition; mm: Sample number; nn: Operation mode.,xx:Range,

CRmmnxx	Description	Result
CR0101LR	Range: 30 MHz - 1000 MHz Horizontal Polarization	P
CR0101LR	Range: 30 MHz - 1000 MHz Vertical Polarization	P
CR0101HR1	Range: 1-18 GHz Horizontal Polarization	P
CR0101HR1	Range: 1-18 GHz Vertical Polarization	P
CR0101HR2	Range: 18-26 GHz Horizontal Polarization	P
CR0101HR2	Range: 18-26 GHz Vertical Polarization	P

Radiated Emission. CR0101LR

Project: 02323ERM005
 Company: Telit
 Sample: S/01
 Operation mode: OM#01
 Description: EUT ON. IDLE. Power Supply: 3.8 Vdc. Both polarizations

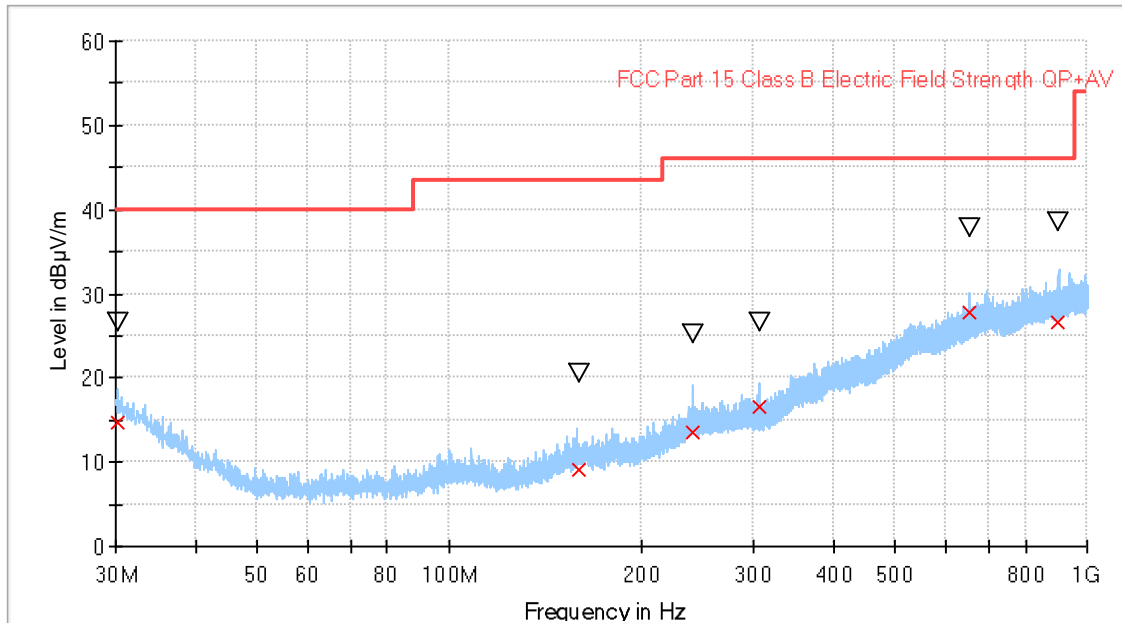

- Preview Result 1-PK+
- FCC Part 15 Class B Electric Field Strength QP+AV
- x Final_Result QPK
- ▽ Final_Result PK+

Final Result

Frequency (MHz)	QuasiPeak (dBµV/m)	MaxPeak (dBµV/m)	Height (cm)	Pol	Azimuth (deg)
30.112200	14.60	26.56	183.0	H	41.0
159.260000	9.19	20.65	132.0	H	-135.0
239.960000	13.59	25.20	170.0	V	26.0
307.250000	16.59	26.65	192.0	H	-110.0
652.830000	27.70	37.75	220.0	V	121.0
902.150000	26.53	38.55	336.0	V	175.0

Radiated Emission. CR0101HR1

Project: 02323ERM005
 Company: Telit
 Sample: S/01
 Operation mode: OM#01
 Description: EUT ON. IDLE. Power Supply: 3.8 Vdc. Both polarizations

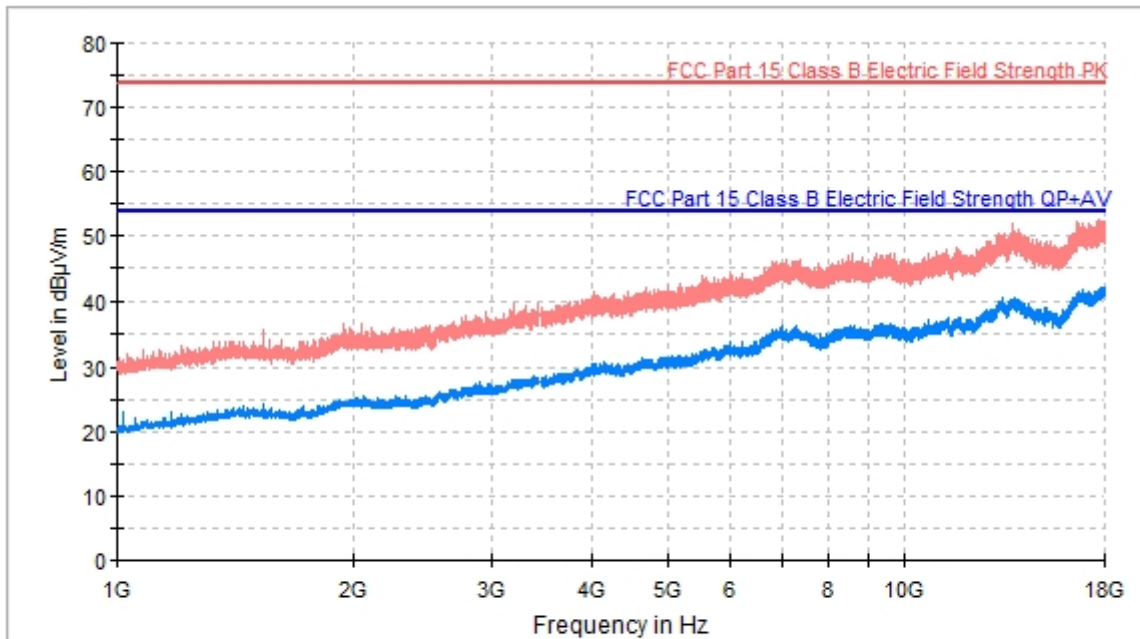

— AVG_MAXH
 — PK+ MAXH
 — FCC Part 15 Class B Electric Field Strength PK
 — FCC Part 15 Class B Electric Field Strength QP+AV

Final Result

Frequency (MHz)	PK+ MAXH (dBµV/m)	AVG_MAXH (dBµV/m)	Pol	Azimuth (deg)
7283.000000	44.61	36.04	H	-179.0
9378.000000	44.91	36.31	H	180.0
11791.000000	46.18	37.50	V	-110.0
13835.000000	48.99	40.42	V	180.0
16885.500000	49.08	41.67	V	180.0
17985.500000	51.27	42.05	V	-58.0

Radiated Emission. CR0101HR2

Project: 02323ERM005
Company: Telit
Sample: S/01
Operation mode: OM#01
Description: EUT ON. IDLE. Power Supply: 3.8 Vdc. Both polarizations

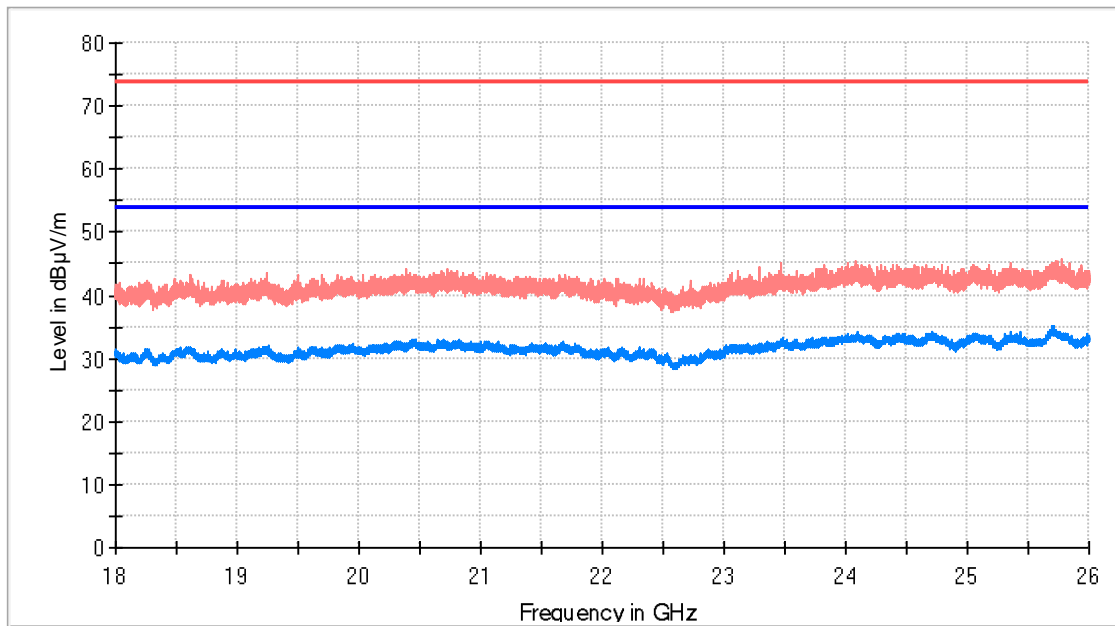

- AVG_MAXH
- PK+_MAXH
- FCC Part 15 Class B Electric Field Strength PK
- FCC Part 15 Class B Electric Field Strength QP+AV