



**FCC 47 CFR PART 22 SUBPART H AND PART 24 SUBPART E
&
INDUSTRY CANADA RSS-132 & RSS-133**

TEST REPORT

For

H24 NA DB/2100

Model: KL1

Trade Name: Telit Wireless Solutions

Issued to

**Telit Communications S.p.A.
Viale Stazione di Prosecco 5/B 34010 Sgonico, Trieste - Italy**

Issued by

**Compliance Certification Services Inc.
No.11, Wugong 6th Rd., Wugu Dist.,
New Taipei City 24891, Taiwan. (R.O.C.)
<http://www.ccsrf.com>
service@ccsrf.com**

Issued Date: February 5, 2014



Note: This report shall not be reproduced except in full, without the written approval of Compliance Certification Services Inc. This document may be altered or revised by Compliance Certification Services Inc. personnel only, and shall be noted in the revision section of the document.



Revision History

Rev.	Issue Date	Revisions	Effect Page	Revised By
00	February 5, 2014	Initial Issue	ALL	Eunice Shen



TABLE OF CONTENTS

1. TEST RESULT CERTIFICATION.....	4
2. EUT DESCRIPTION	5
3. TEST METHODOLOGY	6
3.1 EUT CONFIGURATION	6
3.2 EUT EXERCISE	6
3.3 GENERAL TEST PROCEDURES	6
3.4 DESCRIPTION OF TEST MODES	7
4. INSTRUMENT CALIBRATION.....	8
4.1 MEASURING INSTRUMENT CALIBRATION	8
4.2 MEASUREMENT EQUIPMENT USED	8
4.3 MEASUREMENT UNCERTAINTY	9
5. FACILITIES AND ACCREDITATIONS	10
5.1 FACILITIES	10
5.2 EQUIPMENT	10
5.3 LABORATORY ACCREDITATIONS AND LISTING	10
5.4 TABLE OF ACCREDITATIONS AND LISTINGS	11
6. SETUP OF EQUIPMENT UNDER TEST	12
6.1 SETUP CONFIGURATION OF EUT	12
6.2 SUPPORT EQUIPMENT	12
7. FCC PART 22 & 24 REQUIREMENTS & INDUSTRY CANADA RSS-132 & RSS-133 ...	13
7.1 99% BANDWIDTH	13
7.2 AVERAGE POWER.....	24
7.3 ERP & EIRP MEASUREMENT	26
7.4 OUT OF BAND EMISSION AT ANTENNA TERMINALS	30
7.5 FIELD STRENGTH OF SPURIOUS RADIATION MEASUREMENT	41
7.6 FREQUENCY STABILITY V.S. TEMPERATURE MEASUREMENT	79
7.7 FREQUENCY STABILITY V.S. VOLTAGE MEASUREMENT	83
APPENDIX II PHOTOGRAPHS OF TEST SETUP	87
APPENDIX 1 - PHOTOGRAPHS OF EUT	



1. TEST RESULT CERTIFICATION

Applicant: Telit Communications S.p.A.
 Viale Stazione di Prosecco 5/B 34010 Sgonico, Trieste - Italy

Manufacturer: Telit Communications S.p.A.
 Viale Stazione di Prosecco 5/B 34010 Sgonico, Trieste - Italy

Equipment Under Test: H24 NA DB/2100

Trade Name: Telit Wireless Solutions

Model Number: KL1

Date of Test: January 20 ~ February 5, 2014

APPLICABLE STANDARDS	
STANDARD	TEST RESULT
FCC 47 CFR PART 22 SUBPART H AND PART 24 SUBPART E & IC RSS-132 Issue 3: January 2013 and IC RSS-133 Issue 6: January 2013	No non-compliance noted

We hereby certify that:

The above equipment was tested by Compliance Certification Services Inc. The test data, data evaluation, test procedures, and equipment configurations shown in this report were made in accordance with the procedures given in TIA/EIA-603-C and the energy emitted by the sample EUT tested as described in this report is in compliance with radiated emission limits of FCC Rule FCC PART 22 Subpart H, PART 24 Subpart E, IC RSS-132 Issue 2 and IC RSS-133 Issue 4.

The test results of this report relate only to the tested sample identified in this report.

Approved by:

Reviewed by:

 Miller Lee
 Section Manager
 Compliance Certification Services Inc.

 Angel Cheng
 Section Manager
 Compliance Certification Services Inc.



2. EUT DESCRIPTION

Product	H24 NA DB/2100
Trade Name	Telit Wireless Solutions
Model Number	KL1
Model Discrepancy	N/A
Received Date	January 20, 2014
Power Supply	VDC from Power Adapter I/P: 100-240V, 0.15A, 50-60Hz O/P: 5V, 850mA
Frequency Range	GSM / GPRS / EDGE: 850: 824.2 ~ 848.8 MHz GSM / GPRS / EDGE: 1900: 1850.2 ~ 1909.8 MHz
Transmit Power (ERP & EIRP Power)	GSM 850: 31.28 dBm GPRS 850: 30.78 dBm EDGE 850: 28.00 dBm GSM 1900: 29.59 dBm GPRS 1900: 29.66 dBm EDGE 1900: 27.62 dBm
Modulation Technique	GMSK and 8-PSK
Antenna Gain	GSM/GPRS/ EDGE 850MHz: 0.5 dBi GSM/GPRS/ EDGE 1900MHz: 2.2 dBi
Antenna Type	Dipole Blade Omnidirectional Antenna
Multislot class	Class 12

Remark: The sample selected for test was engineering sample that approximated to production product and was provided by manufacturer.

Mode	ERP Power (dBm)	ERP Power (w)	Type of Emission (99% Bandwidth)	Type of Emission (Occupied Bandwidth)
GSM 850MHz	31.28	1.3428	243KGXW	322KGXW
GPRS 850MHz	30.78	1.1967	244KGXW	322KGXW
EDGE 850MHz	28.00	0.6310	244KG7W	321KG7W
GSM 1900MHz	29.59	0.9099	246KGXW	330KGXW
GPRS 1900MHz	29.66	0.9247	247KGXW	330KGXW
EDGE 1900MHz	27.62	0.5781	246KG7W	330KG7W



3. TEST METHODOLOGY

Both conducted and radiated testing were performed according to the procedures document on chapter 13 of ANSI C63.4: 2009, TIA/EIA-603-C: 2004 and FCC CFR 47, Part 2 and Part 22 Subpart H & Part 24 Subpart E.

The tests documented in this report were performed in accordance with IC RSS-132, SPSR503, RSS-133, SPSR510 and ANSI C63.4 and TIA/EIA-603-C.

3.1 EUT CONFIGURATION

The EUT configuration for testing is installed on RF field strength measurement to meet the Commissions requirement and operating in a manner that intends to maximize its emission characteristics in a continuous normal application.

3.2 EUT EXERCISE

The EUT was operated in the engineering mode to fix the TX frequency that was for the purpose of the measurements.

3.3 GENERAL TEST PROCEDURES

Conducted Emissions

The EUT is placed on the turntable, which is 0.8 m above ground plane. According to the requirements in Section 13.1.4.1 of ANSI C63.4: 2009. Conducted emissions from the EUT measured in the frequency range between 0.15 MHz and 30MHz using CISPR Quasi-peak and average detector modes.

Radiated Emissions

The EUT is placed on a turn table, which is 0.8 m above ground plane. The turntable shall rotate 360 degrees to determine the position of maximum emission level. EUT is set 3m away from the receiving antenna, which varied from 1m to 4m to find out the highest emission. And also, each emission was to be maximized by changing the polarization of receiving antenna both horizontal and vertical. In order to find out the maximum emissions, exploratory radiated emission measurements were made according to the requirements in Section 13.1.4.1 of ANSI C63.4: 2009.



3.4 DESCRIPTION OF TEST MODES

The EUT (model: KL1) had been tested under operating condition.

EUT staying in continuous transmitting mode was programmed.

After verification, all tests carried out are with the worst-case test modes as shown below except radiated spurious emission below 1GHz which worst case was in normal link mode.

GSM / GPRS / EDGE 850MHz:

Channel Low (CH128), Channel Mid (CH190) and Channel High (CH251) were chosen for full testing.

GSM / GPRS / EDGE 1900MHz:

Channel Low (CH512), Channel Mid (CH661) and Channel High (CH810) were chosen for full

Based on the above results from the different modulations, GSM850 / GSM1900 / GPRS 850 / GPRS1900 / EDGE 850 / EDGE 1900 were determined to be the worst-case scenario for all tests.



4. INSTRUMENT CALIBRATION

4.1 MEASURING INSTRUMENT CALIBRATION

The measuring equipment, which was utilized in performing the tests documented herein, has been calibrated in accordance with the manufacturer's recommendations for utilizing calibration equipment, which is traceable to recognized national standards.

4.2 MEASUREMENT EQUIPMENT USED

Equipment Used for Emissions Measurement

Remark: Each piece of equipment is scheduled for calibration once a year and Loop Antenna is scheduled for calibration once three years.

Conducted Emissions Test Site				
Name of Equipment	Manufacturer	Model	Serial Number	Calibration Due
Spectrum Analyzer	Agilent	E4446A	MY43360131	03/20/2014
Power Meter	Anritsu	ML2495A	1012009	06/04/2014
Power Sensor	Anritsu	MA2411A	0917072	06/04/2014
Temp. / Humidity Chamber	Terchy	MHG-150LF	930619	10/17/2014

Wugu 966 Chamber A				
Name of Equipment	Manufacturer	Model	Serial Number	Calibration Due
Spectrum Analyzer	Agilent	E4446A	US42510268	11/13/2014
EMI Test Receiver	R&S	ESCI	100064	02/28/2014
Pre-Amplifier	Mini-Circults	ZFL-1000LN	SF350700823	01/11/2015
Pre-Amplifier	MITEQ	AFS44-00102650-42-10P-44	1415367	11/18/2014
Bilog Antenna	Sunol Sciences	JB3	A030105	10/01/2014
Bilog Antenna	Sunol Sciences	JB3	A030205	10/01/2014
Horn Antenna	EMCO	3117	00055165	02/13/2014
Horn Antenna	EMCO	3117	00055167	01/27/2015
Horn Antenna	EMCO	3116	00026370	10/10/2014
Loop Antenna	EMCO	6502	8905/2356	06/09/2014
Turn Table	CCS	CC-T-1F	N/A	N.C.R
Antenna Tower	CCS	CC-A-1F	N/A	N.C.R
Controller	CCS	CC-C-1F	N/A	N.C.R
Site NSA	CCS	N/A	N/A	12/21/2014
Test S/W	EZ-EMC (CCS-3A1RE)			



4.3 MEASUREMENT UNCERTAINTY

PARAMETER	UNCERTAINTY
3M Semi Anechoic Chamber / 30M~200M	+/- 4.0138
3M Semi Anechoic Chamber / 200M~1000M	+/- 3.9483
3M Semi Anechoic Chamber / 1G~8G	+/- 2.5975
3M Semi Anechoic Chamber / 8G~18G	+/- 2.6112
3M Semi Anechoic Chamber / 18G~26G	+/- 2.7389
3M Semi Anechoic Chamber / 26G~40G	+/- 2.9683

Remark: This uncertainty represents an expanded uncertainty expressed at approximately the 95% confidence level using a coverage factor of $k=2$.



5. FACILITIES AND ACCREDITATIONS

5.1 FACILITIES

All measurement facilities used to collect the measurement data are located at

No.199, Chunghsen Road, Hsintien City, Taipei Hsien, Taiwan, R.O.C.
Tel: 886-2-2217-0894 / Fax: 886-2-2217-1029

No.11, Wugong 6th Rd., Wugu Dist., New Taipei City 24891, Taiwan. (R.O.C.)
Tel: 886-2-2299-9720 / Fax: 886-2-2298-4045

No.81-1, Lane 210, Bade 2nd Rd., Lujhu Township, Taoyuan County 33841, TAIWAN,
R.O.C.
Tel: 886-3-324-0332 / Fax: 886-3-324-5235

The sites are constructed in conformance with the requirements of ANSI C63.7, ANSI C63.4: 2009 and CISPR Publication 22.

5.2 EQUIPMENT

Radiated emissions are measured with one or more of the following types of linearly polarized antennas: tuned dipole, biconical, log periodic, bi-log, and/or ridged waveguide, horn. Spectrum analyzers with pre-selectors and quasi-peak detectors are used to perform radiated measurements.

Conducted emissions are measured with Line Impedance Stabilization Networks and EMI Test Receivers.

Calibrated wideband preamplifiers, coaxial cables, and coaxial attenuators are also used for making measurements.



All receiving equipment conforms to CISPR Publication 16-1, "Radio Interference Measuring Apparatus and Measurement Methods."

5.3 LABORATORY ACCREDITATIONS AND LISTING

The test facilities used to perform radiated and conducted emissions tests are accredited by American Association for Laboratory Accreditation Program for the specific scope accreditation under Lab Code: 0824-01 to perform Electromagnetic Interference tests according to FCC Part 15 and CISPR 22 requirements. In addition, the test facilities are listed with Industry Canada, Certification and Engineering Bureau, IC 2324G-1 for 3M Semi Anechoic Chamber A, 2324G-2 for 3M Semi Anechoic Chamber B.



5.4 TABLE OF ACCREDITATIONS AND LISTINGS

Country	Agency	Scope of Accreditation	Logo
USA	FCC	3M Semi Anechoic Chamber (FCC MRA: TW1039) to perform FCC Part 15 measurements	 FCC MRA: TW1039
Taiwan	TAF	LP0002, RTTE01, FCC Method-47 CFR Part 15 Subpart C, D, E, RSS-210, RSS-310 IDA TS SRD, AS/NZS 4268, AS/NZS 4771, TS 12.1 & 12.2, ETSI EN 300 440-1, ETSI EN 300 440-2, ETSI EN 300 328, ETSI EN 300 220-1, ETSI EN 300 220-2, ETSI EN 301 893, ETSI EN 301 489-1/3/7/17 FCC OET Bulletin 65 + Supplement C, EN 50360, EN 50361, EN 50371, RSS 102, EN 50383, EN 50385, EN 50392, IEC 62209, CNS 14958-1, CNS 14959 FCC Method -47 CFR Part 15 Subpart B IEC / EN 61000-3-2, IEC / EN 61000-3-3, IEC / EN 61000-4-2/3/4/5/6/8/11	 Testing Laboratory 1309
Canada	Industry Canada	3M Semi Anechoic Chamber (IC 2324G-1 / IC 2324G-2) to perform	 IC 2324G-1 IC 2324G-2

** No part of this report may be used to claim or imply product endorsement by A2LA or any agency of the US Government.*



6. SETUP OF EQUIPMENT UNDER TEST

6.1 SETUP CONFIGURATION OF EUT

See test photographs attached in Appendix II for the actual connections between EUT and support equipment.

6.2 SUPPORT EQUIPMENT

No.	Device Type	Brand	Model	Series No.	FCC ID	Data Cable	Power Cord
1.	8960 Series 10 Wireless Communication test set (Remote)	Agilent	E5515C	GB44051665	N/A	N/A	Unshielded, 1.8m

Remark:

1. All the equipment/cables were placed in the worst-case configuration to maximize the emission during the test.
2. Grounding was established in accordance with the manufacturer's requirements and conditions for the intended use.



7. FCC PART 22 & 24 REQUIREMENTS & INDUSTRY CANADA RSS-132 & RSS-133

7.1 99% BANDWIDTH

LIMIT

None; for reporting purposes only.

Test Configuration

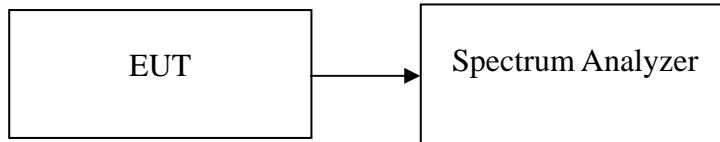

TEST PROCEDURE

The transmitter output is connected to the spectrum analyzer. The RBW is set to 1% to 3% of the 99 % bandwidth. The VBW is set to 3 times the RBW. The sweep time is coupled.

TEST RESULTS

No non-compliance noted.



Test Data

Test Mode	CH	Frequency (MHz)	99% Bandwidth (kHz)	Occupied Bandwidth (kHz)
GSM 850	128	824.200	242.9156	321.429
	190	836.400	243.4297	322.582
	251	848.800	242.7655	319.985
GPRS 850	128	824.200	243.1186	321.429
	190	836.400	244.4146	322.499
	251	848.800	241.2781	322.104
GSM 1900	512	1850.210	243.5306	325.157
	661	1880.000	244.1716	324.779
	810	1909.823	246.9757	330.482
GPRS 1900	512	1850.210	243.1213	325.655
	661	1880.000	244.1939	325.929
	810	1909.823	247.1609	330.482
EDGE 850	128	824.200	242.6539	321.429
	190	836.570	244.5463	320.624
	251	848.800	242.7335	321.764
EDGE 1900	512	1850.173	242.8890	326.246
	661	1880.000	244.2189	325.020
	810	1909.800	246.5889	330.482



Test Plot

GSM 850 (CH Low)

Agilent

R T

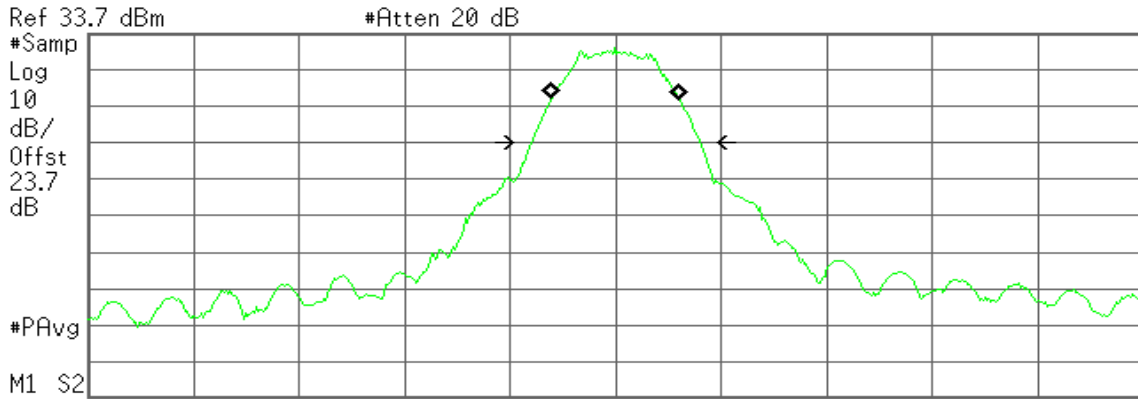

Occupied Bandwidth
242.9156 kHz

Occ BW % Pwr 99.00 %
x dB -26.00 dB

Transmit Freq Error -250.388 Hz
x dB Bandwidth 321.429 kHz*

GSM 850 (CH Mid)

Agilent

R T

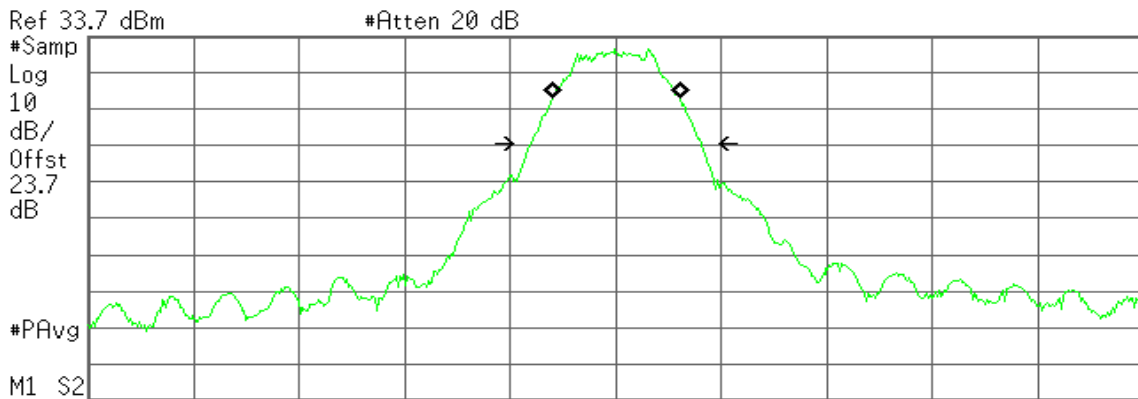

Occupied Bandwidth
243.4297 kHz

Occ BW % Pwr 99.00 %
x dB -26.00 dB

Transmit Freq Error 851.841 Hz
x dB Bandwidth 322.582 kHz*



GSM 850 (CH High)

Agilent

R T

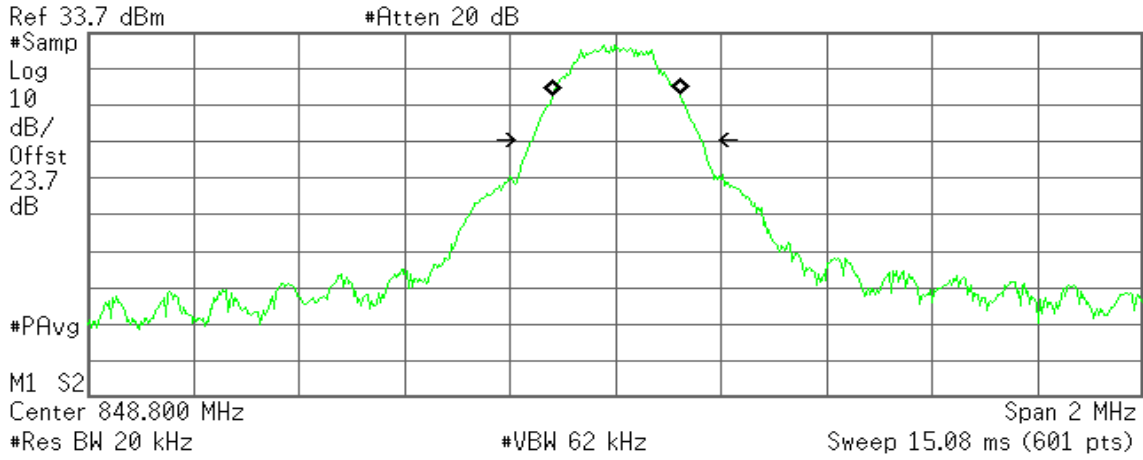

Occupied Bandwidth
242.7655 kHz

Occ BW % Pwr 99.00 %
x dB -26.00 dB

Transmit Freq Error 982.988 Hz
x dB Bandwidth 319.985 kHz*

GPRS 850 (CH Low)

Agilent

R T

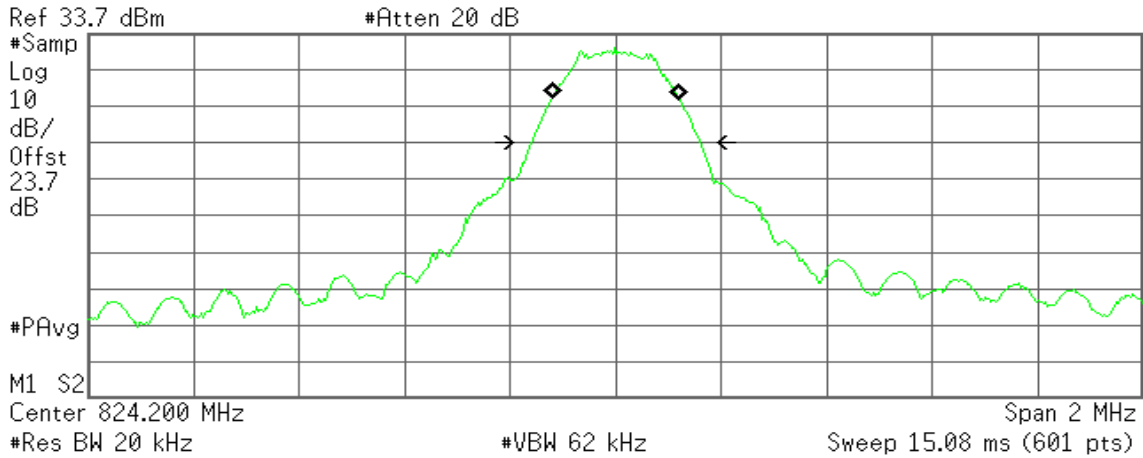

Occupied Bandwidth
243.1186 kHz

Occ BW % Pwr 99.00 %
x dB -26.00 dB

Transmit Freq Error -83.204 Hz
x dB Bandwidth 321.429 kHz*



GPRS 850 (CH Mid)

Agilent

R T

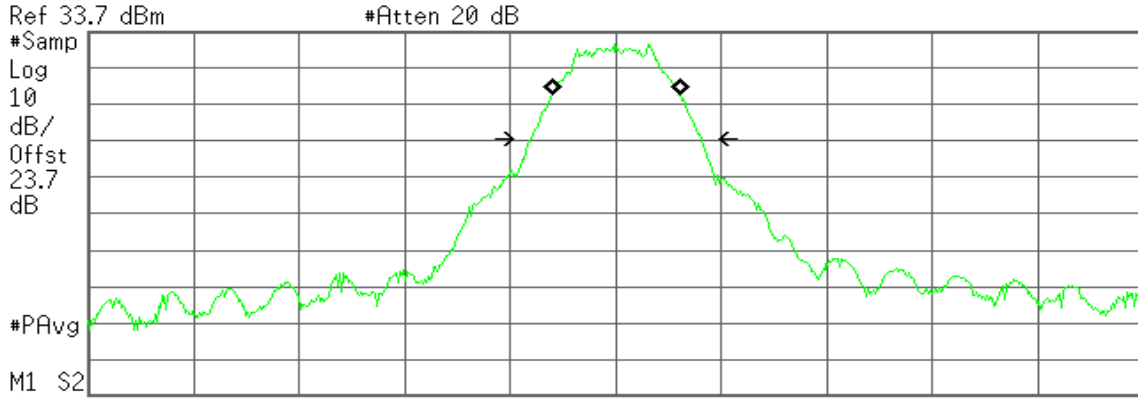

Center 836.600 MHz Span 2 MHz
 #Res BW 20 kHz #VBW 62 kHz Sweep 15.08 ms (601 pts)

Occupied Bandwidth
 244.4146 kHz

Occ BW % Pwr 99.00 %
x dB -26.00 dB

Transmit Freq Error 844.455 Hz
x dB Bandwidth 322.499 kHz*

GPRS 850(CH High)

Agilent

R T

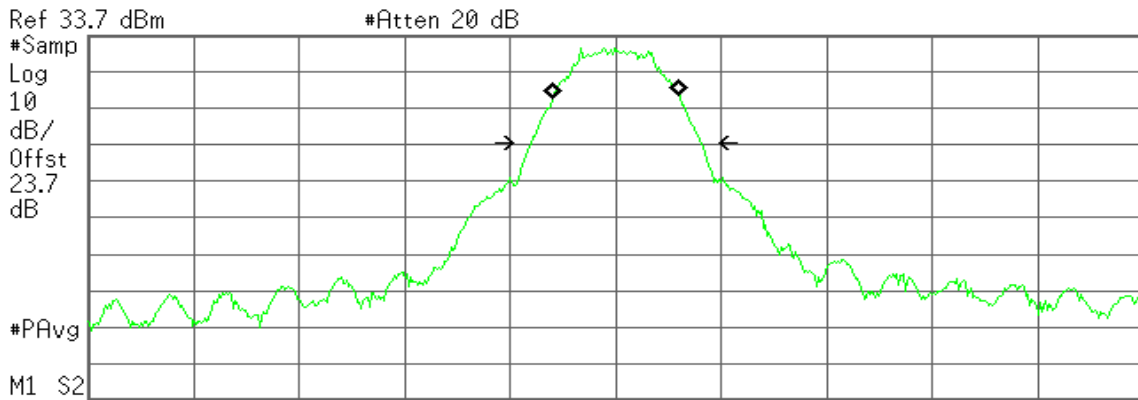

Center 848.800 MHz Span 2 MHz
 #Res BW 20 kHz #VBW 62 kHz Sweep 15.08 ms (601 pts)

Occupied Bandwidth
 241.2781 kHz

Occ BW % Pwr 99.00 %
x dB -26.00 dB

Transmit Freq Error 977.725 Hz
x dB Bandwidth 322.104 kHz*



GSM 1900 (CH Low)

Agilent

R T

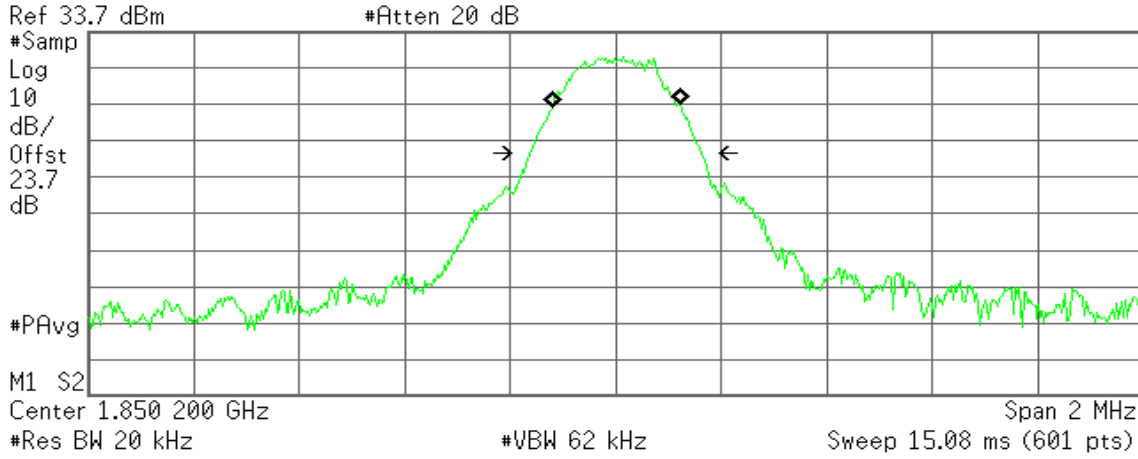

Occupied Bandwidth
243.5306 kHz

Occ BW % Pwr 99.00 %
x dB -26.00 dB

Transmit Freq Error 1.274 kHz
x dB Bandwidth 325.157 kHz*

GSM 1900 (CH Mid)

Agilent

R T

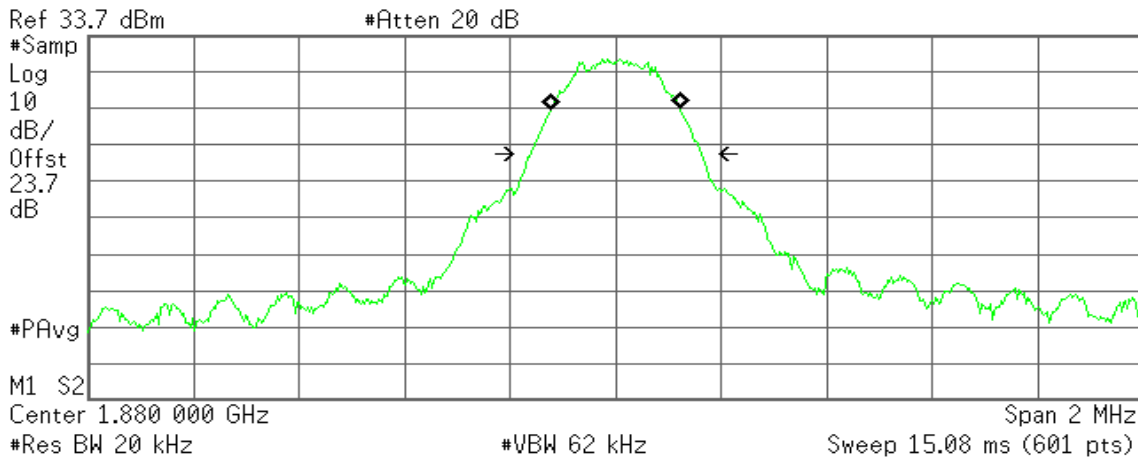

Occupied Bandwidth
244.1716 kHz

Occ BW % Pwr 99.00 %
x dB -26.00 dB

Transmit Freq Error 555.216 mHz
x dB Bandwidth 324.779 kHz*



GSM 1900 (CH High)

Agilent

R T

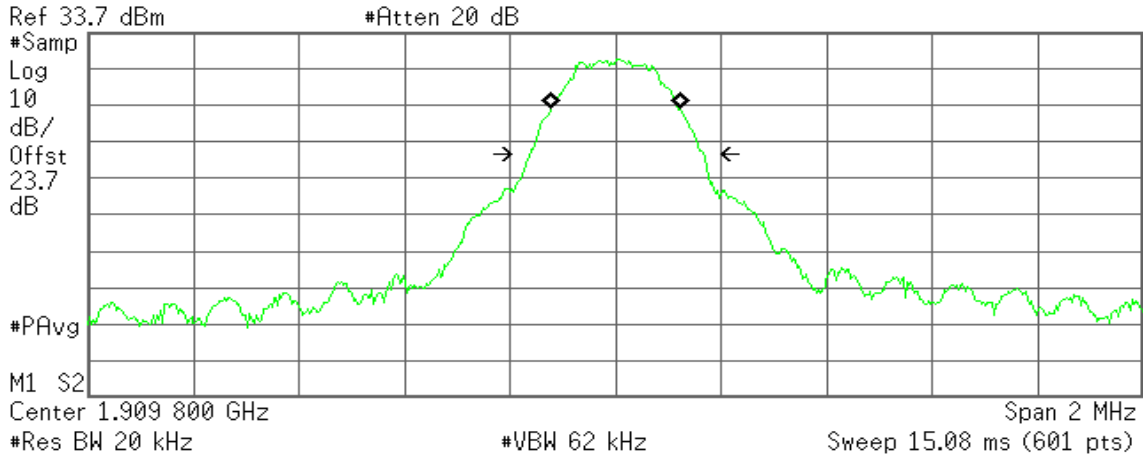

Occupied Bandwidth
246.9757 kHz

Occ BW % Pwr 99.00 %
x dB -26.00 dB

Transmit Freq Error -64.449 Hz
x dB Bandwidth 330.482 kHz*

GPRS 1900 (CH Low)

Agilent

R T

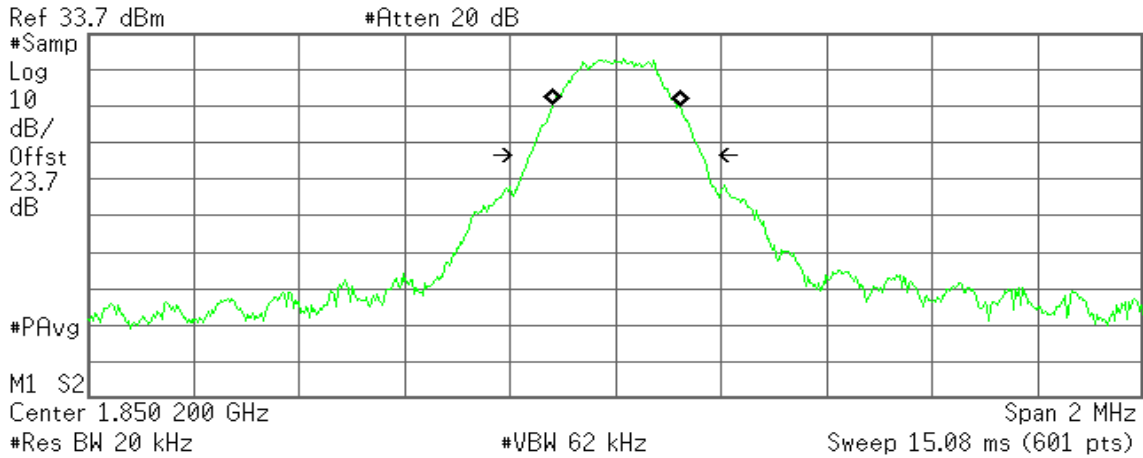

Occupied Bandwidth
243.1213 kHz

Occ BW % Pwr 99.00 %
x dB -26.00 dB

Transmit Freq Error 912.450 Hz
x dB Bandwidth 325.655 kHz*



GPRS 1900 (CH Mid)

Agilent

R T

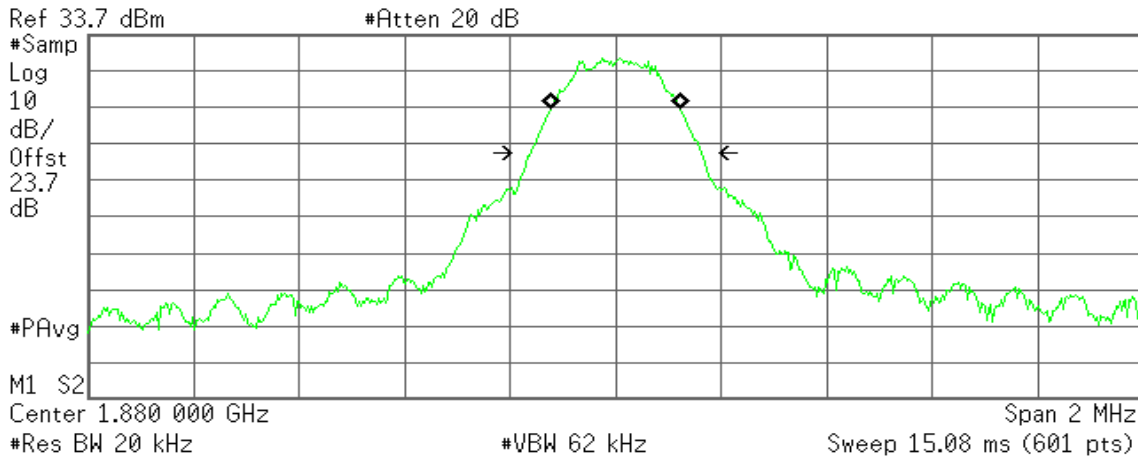

Occupied Bandwidth
244.1939 kHz

Occ BW % Pwr 99.00 %
x dB -26.00 dB

Transmit Freq Error -392.725 Hz
x dB Bandwidth 325.929 kHz*

GPRS 1900 (CH High)

Agilent

R T

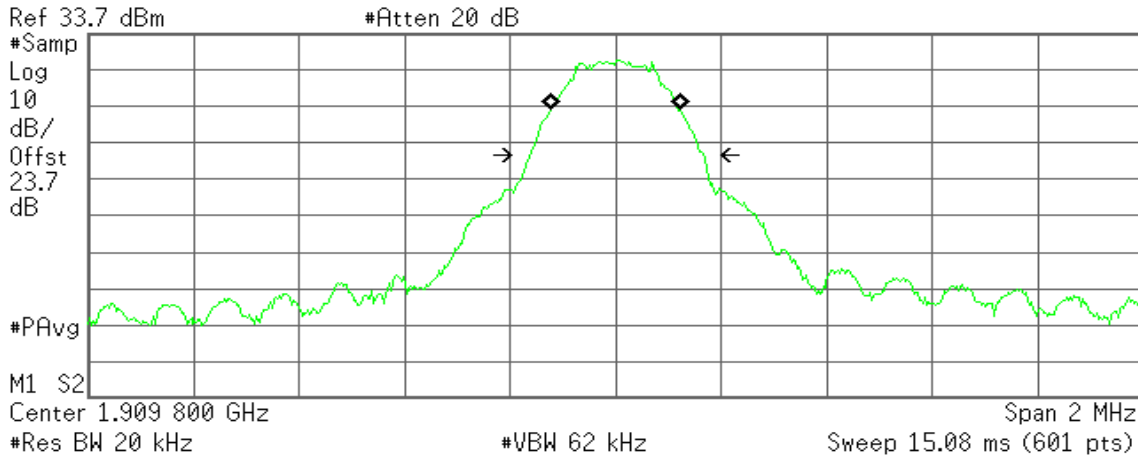

Occupied Bandwidth
247.1609 kHz

Occ BW % Pwr 99.00 %
x dB -26.00 dB

Transmit Freq Error -327.363 Hz
x dB Bandwidth 330.482 kHz*



EDGE 850 (CH Low)

Agilent

R T

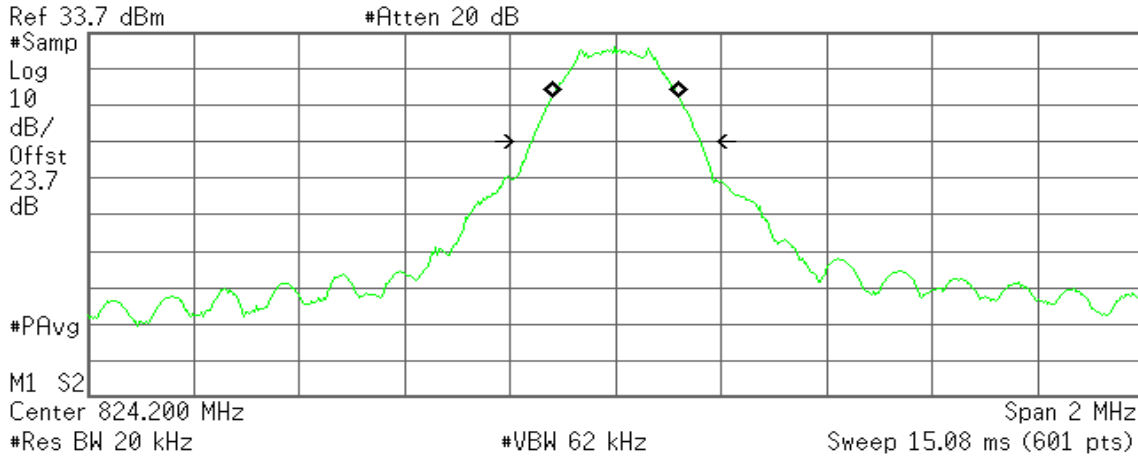

Occupied Bandwidth
242.6539 kHz

Occ BW % Pwr 99.00 %
x dB -26.00 dB

Transmit Freq Error -80.101 Hz
x dB Bandwidth 321.429 kHz*

EDGE 850 (CH Mid)

Agilent

R T

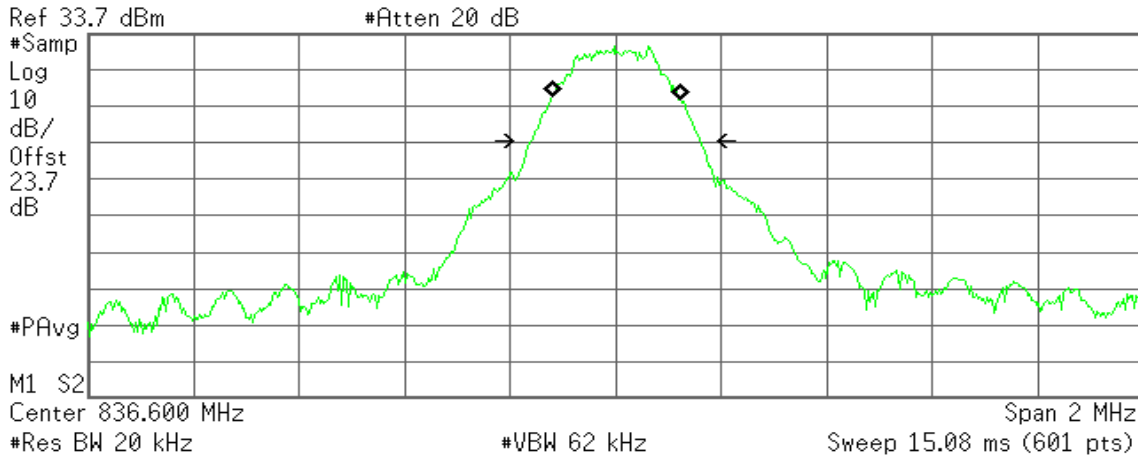

Occupied Bandwidth
244.5463 kHz

Occ BW % Pwr 99.00 %
x dB -26.00 dB

Transmit Freq Error 650.190 Hz
x dB Bandwidth 320.624 kHz*



EDGE 850 (CH High)

Agilent

R T

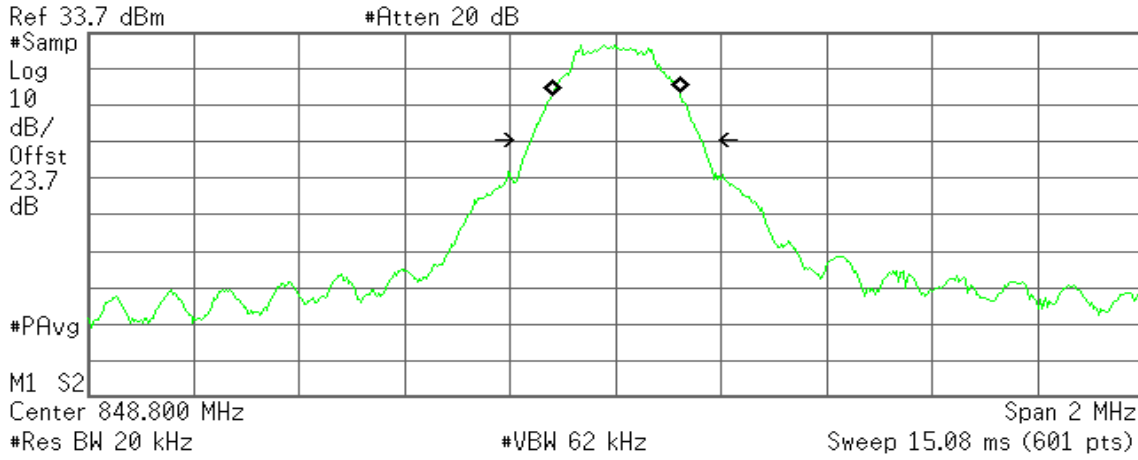

Occupied Bandwidth
242.7335 kHz

Occ BW % Pwr 99.00 %
x dB -26.00 dB

Transmit Freq Error 494.969 Hz
x dB Bandwidth 321.764 kHz*

EDGE 1900 (CH Low)

Agilent

R T

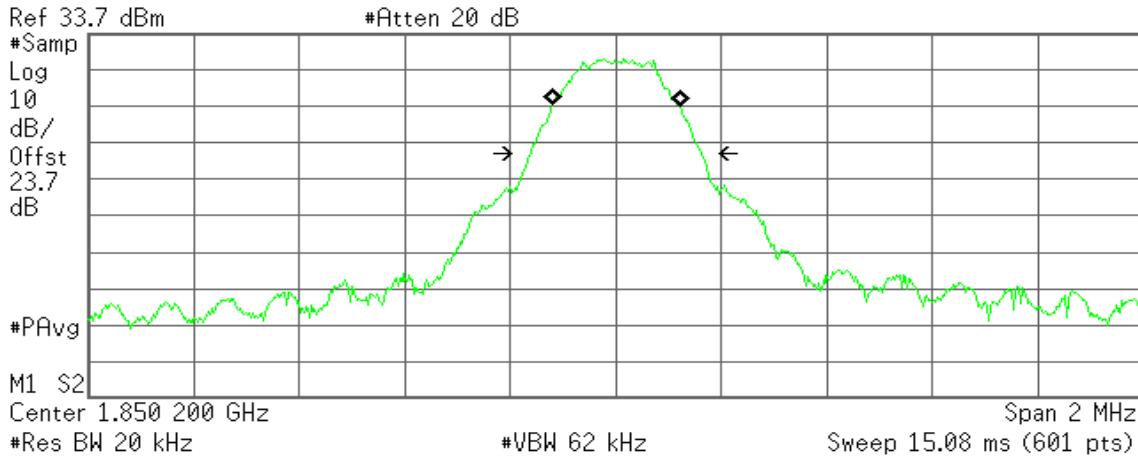

Occupied Bandwidth
242.8890 kHz

Occ BW % Pwr 99.00 %
x dB -26.00 dB

Transmit Freq Error 894.242 Hz
x dB Bandwidth 326.246 kHz*



EDGE 1900 (CH Mid)

Agilent

R T

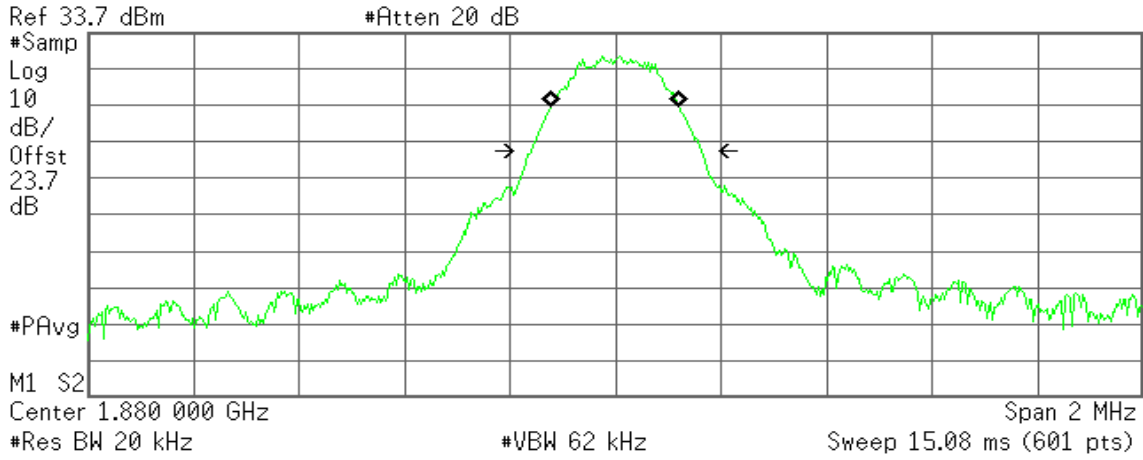

Occupied Bandwidth
244.2189 kHz

Occ BW % Pwr 99.00 %
x dB -26.00 dB

Transmit Freq Error -923.675 Hz
x dB Bandwidth 325.020 kHz*

EDGE 1900 (CH High)

Agilent

R T

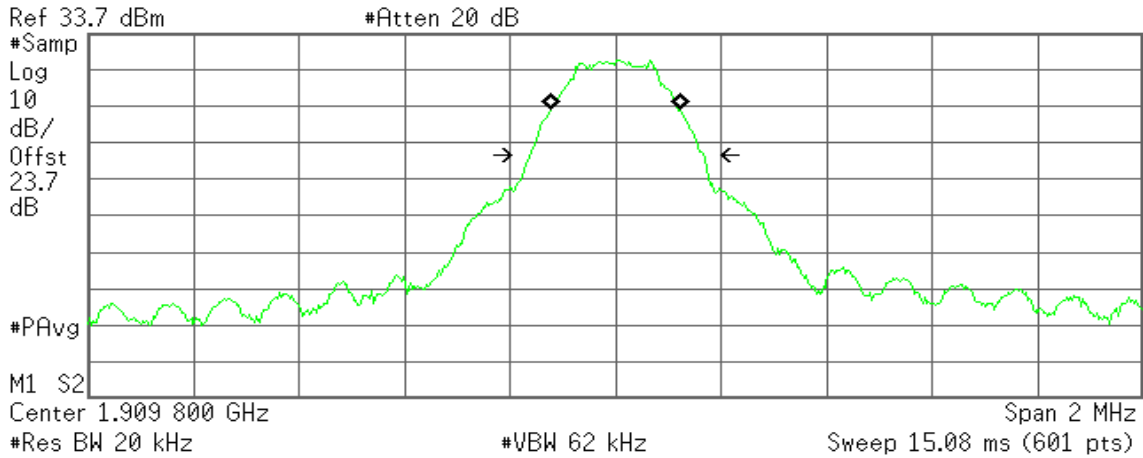

Occupied Bandwidth
246.5889 kHz

Occ BW % Pwr 99.00 %
x dB -26.00 dB

Transmit Freq Error -324.126 Hz
x dB Bandwidth 330.482 kHz*



7.2 AVERAGE POWER

LIMIT

For reporting purposes only.

Test Configuration

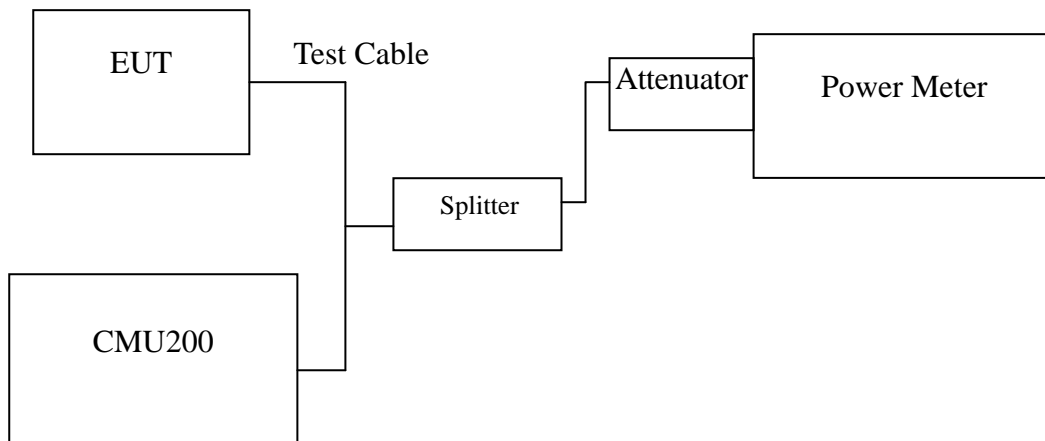

Remark: Measurement setup for testing on Antenna connector

TEST PROCEDURE

The transmitter output was connected to a calibrated attenuator, the other end of which was connected to a power meter. Transmitter output was read off the power meter in dBm. The power output at the transmitter antenna port was determined by adding the value of the attenuator to the power meter reading.

TEST RESULTS

No non-compliance noted.



Test Data

Test Mode	CH	Frequency (MHz)	Average Power (dBm)	Output Power (W)
GSM 850	128	824.20	33.70	2.34423
	190	836.40	33.40	2.18776
	251	848.80	33.50	2.23872
GPRS 850 (Class 12)	128	824.20	33.60	2.29087
	190	836.40	33.40	2.18776
	251	848.80	33.50	2.23872
EDGE 850 (Class 12)	128	824.20	27.40	0.54954
	190	836.40	27.50	0.56234
	251	848.80	27.40	0.54954

Test Mode	CH	Frequency (MHz)	Average Power (dBm)	Output Power (W)
GSM 1900	512	1850.20	30.50	1.12202
	661	1880.00	30.80	1.20226
	810	1909.80	30.30	1.07152
GPRS 1900 (Class 12)	512	1850.20	30.40	1.09648
	661	1880.00	30.60	1.14815
	810	1909.80	30.30	1.07152
EDGE 1900 (Class 12)	512	1850.20	26.80	0.47863
	661	1880.00	27.00	0.50119
	810	1909.80	26.70	0.46774

Remark: The value of factor includes both the loss of cable and external attenuator



7.3 ERP & EIRP MEASUREMENT

LIMIT

According to FCC §2.1046

FCC 22.913(b): The Effective Radiated Power (ERP) of mobile transmitters must not exceed 7 Watts.

RSS-132 § 4.4 The maximum (ERP) shall be 6.3 Watts for mobile stations.

FCC 24.232(b): The equivalent Isotropic Radiated Power (EIRP) must not exceed 2 Watts.

RSS133 § 6.4: Mobile stations and hand-held portables are limited to 2 watts maximum (EIRP).

Test Configuration

Below 1 GHz

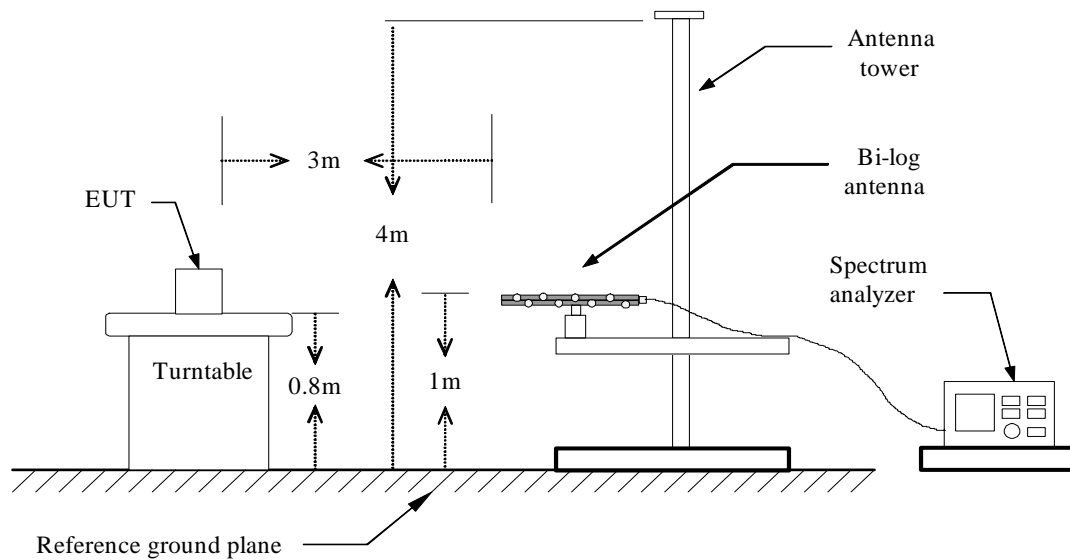

Above 1 GHz

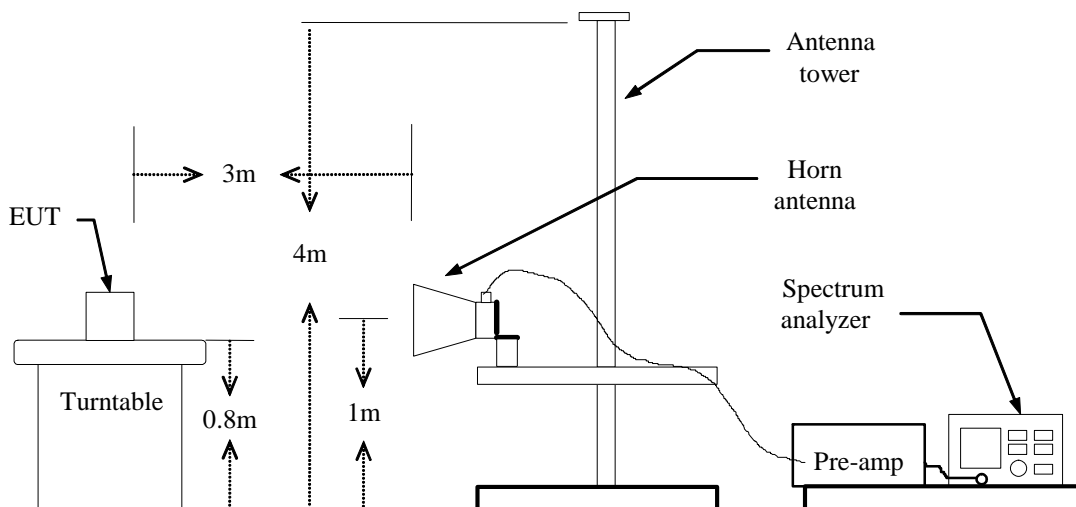



For Substituted Method Test Set-UP

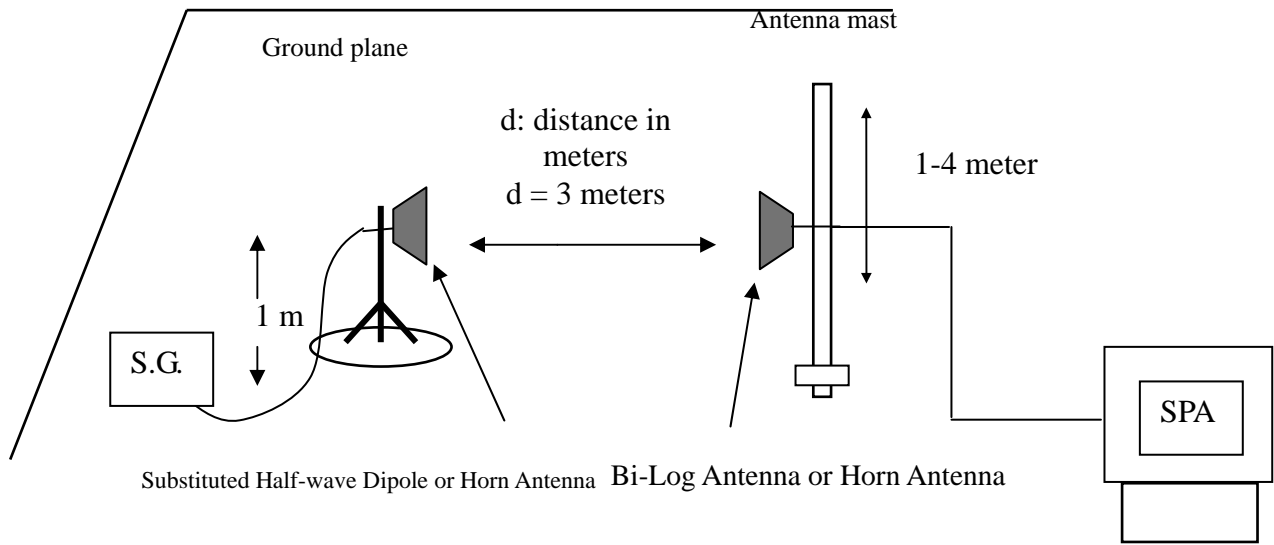

TEST PROCEDURE

The EUT was placed on a non-conductive turntable using a non-conductive support. The radiated emission at the fundamental frequency was measured at 3 m with a test antenna and EMI spectrum analyzer.

During the measurement of the EUT, the resolution bandwidth was set to 5MHz and the average bandwidth was set to 50MHz. The highest emission was recorded with the rotation of the turntable and the lowering of the test antenna. The reading was recorded and the field strength (E in dBuV/m) was calculated.

ERP in frequency band 824-849MHz, and EIRP in frequency band 1851.25 –1910MHz were measured using a substitution method. The EUT was replaced by half-wave dipole (824-849MHz) or horn antenna (1851.25-1910MHz) connected to a signal generator. The spectrum analyzer reading was recorded and ERP/EIRP was calculated as follows:

$$\text{ERP} = \text{S.G. output (dBm)} + \text{Antenna Gain (dBi)} - \text{Cable (dB)} - 2.15$$

$$\text{EIRP} = \text{S.G. output (dBm)} + \text{Antenna Gain (dBi)} - \text{Cable (dB)}$$

TEST RESULTS

No non-compliance noted.

**GSM 850 TEST DATA**

Channel	Frequency (MHz)	Antenna Pol.	S.G. (dBm)	Cable loss (dB)	Ant.Gain (dBi)	Emission level (dBm)	Limit (dBm)	Margin (dB)
128	824.20	V	21.07	3.39	6.24	23.92	38.45	-14.53
	824.20	H	28.43	3.39	6.24	*31.28	38.45	-7.17
190	836.60	V	20.8	3.4	6.36	23.76	38.45	-14.69
	836.60	H	26.82	3.4	6.37	29.79	38.45	-8.66
251	848.80	V	20.75	3.4	6.4	23.75	38.45	-14.70
	848.80	H	26.58	3.4	6.4	29.58	38.45	-8.87

GPRS 850 TEST DATA (CLASS 12)

Channel	Frequency (MHz)	Antenna Pol.	S.G. (dBm)	Cable loss (dB)	Ant.Gain (dBi)	Emission level (dBm)	Limit (dBm)	Margin (dB)
128	824.20	V	21.03	3.39	6.24	23.88	38.45	-14.57
	824.20	H	27.93	3.39	6.24	*30.78	38.45	-7.67
190	836.60	V	18.83	3.4	6.37	21.80	38.45	-16.65
	836.60	H	25.62	3.4	6.37	28.59	38.45	-9.86
251	848.80	V	20.59	3.4	6.4	23.59	38.45	-14.86
	848.80	H	26.14	3.4	6.4	29.14	38.45	-9.31

EGPRS 850 TEST DATA (CLASS 12)

Channel	Frequency (MHz)	Antenna Pol.	S.G. (dBm)	Cable loss (dB)	Ant.Gain (dBi)	Emission level (dBm)	Limit (dBm)	Margin (dB)
512	1850.20	V	11.07	3.39	6.24	13.92	38.45	-24.53
	1850.20	H	23.05	3.39	6.24	25.90	38.45	-12.55
661	1880.00	V	11.18	3.4	6.37	14.15	38.45	-24.30
	1880.00	H	24.59	3.4	6.37	27.56	38.45	-10.89
810	1909.80	V	11.64	3.4	6.4	14.64	38.45	-23.81
	1909.80	H	25	3.4	6.4	*28.00	38.45	-10.45

**GSM 1900 TEST DATA**

Channel	Frequency (MHz)	Antenna Pol.	S.G. (dBm)	Cable loss (dB)	Ant.Gain (dBi)	Emission level (dBm)	Limit (dBm)	Margin (dB)
512	1850.20	V	28.51	5.37	5.67	28.81	33.00	-4.19
	1850.20	H	23.38	5.37	5.67	23.68	33.00	-9.32
661	1880.00	V	29.16	5.42	5.62	29.36	33.00	-3.64
	1880.00	H	21.2	5.42	5.62	21.40	33.00	-11.60
810	1909.80	V	29.51	5.48	5.56	*29.59	33.00	-3.41
	1909.80	H	21.16	5.48	5.56	21.24	33.00	-11.76

GPRS 1900 TEST DATA (CLASS 12)

Channel	Frequency (MHz)	Antenna Pol.	S.G. (dBm)	Cable loss (dB)	Ant.Gain (dBi)	Emission level (dBm)	Limit (dBm)	Margin (dB)
512	1850.20	V	28.78	5.37	5.67	29.08	33.00	-3.92
	1850.20	H	23.56	5.37	5.67	23.86	33.00	-9.14
661	1880.00	V	29.2	5.42	5.62	29.40	33.00	-3.60
	1880.00	H	21.16	5.42	5.62	21.36	33.00	-11.64
810	1909.80	V	29.58	5.48	5.56	*29.66	33.00	-3.34
	1909.80	H	21.7	5.48	5.56	21.78	33.00	-11.22

EGPRS 1900 TEST DATA (CLASS 12)

Channel	Frequency (MHz)	Antenna Pol.	S.G. (dBm)	Cable loss (dB)	Ant.Gain (dBi)	Emission level (dBm)	Limit (dBm)	Margin (dB)
512	1850.20	V	25.82	5.37	5.67	26.12	33.00	-6.88
	1850.20	H	20.58	5.37	5.67	20.88	33.00	-12.12
661	1880.00	V	27.11	5.42	5.62	27.31	33.00	-5.69
	1880.00	H	19.23	5.42	5.62	19.43	33.00	-13.57
810	1909.80	V	27.54	5.48	5.56	*27.62	33.00	-5.38
	1909.80	H	19.74	5.48	5.56	19.82	33.00	-13.18



7.4 OUT OF BAND EMISSION AT ANTENNA TERMINALS

LIMIT

According to FCC §2.1051, FCC §22.917, FCC §24.238(a), RSS-132 (4.5.2), RSS-133 (6.6).

Out of Band Emissions: The mean power of emission must be attenuated below the mean power of the non-modulated carrier (P) on any frequency twice or more than twice the fundamental frequency by at least $43 + 10 \log P$ dB.

Mobile Emissions in Base Frequency Range: The mean power of any emissions appearing in the base station frequency range from cellular mobile transmitters operated must be attenuated to a level not exceed -80 dBm at the transmit antenna connector.

Band Edge Requirements: In the 1MHz bands immediately outside and adjacent to the frequency block, a resolution bandwidth of at least 1% of the emission bandwidth of the fundamental emission of the transmitter may be employed to measure the Out of band Emission

Test Configuration

Out of band emission at antenna terminals:

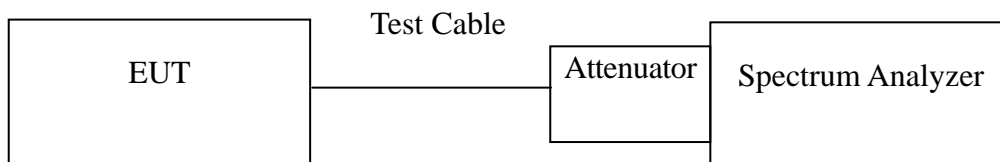

TEST PROCEDURE

The RF output of the transceiver was connected to a spectrum analyzer through appropriate attenuation. The resolution bandwidth of the spectrum analyzer was set at 1MHz, sufficient scans were taken to show the out of band Emissions if any up to 10th harmonic.

For the out of band: Set the RBW, VBW = 1MHz, Start=30MHz, Stop= 10 th harmonic. Limit = -13dBm

Band Edge Requirements (824 MHz and 849 MHz /1850MHz and 1910MHz): In the 1 MHz bands immediately outside and adjacent to the frequency block, a resolution bandwidth of at least 1 percent of the emission bandwidth of the fundamental emission of the transmitter may be employed to measure the out of band Emissions. Limit, -13dBm.

TEST RESULTS

No non-compliance noted.



Test Data

Mode	CH	Location	Description
GSM 850	128	Figure 7-1	Conducted spurious emissions, 30MHz - 20GHz
	190	Figure 7-2	Conducted spurious emissions, 30MHz - 20GHz
	251	Figure 7-3	Conducted spurious emissions, 30MHz - 20GHz
GPRS 850	128	Figure 8-1	Conducted spurious emissions, 30MHz - 20GHz
	190	Figure 8-2	Conducted spurious emissions, 30MHz - 20GHz
	251	Figure 8-3	Conducted spurious emissions, 30MHz - 20GHz

Mode	CH	Location	Description
GSM 1900	512	Figure 9-1	Conducted spurious emissions, 30MHz - 20GHz
	661	Figure 9-2	Conducted spurious emissions, 30MHz - 20GHz
	810	Figure 9-3	Conducted spurious emissions, 30MHz - 20GHz
GPRS 1900	512	Figure 10-1	Conducted spurious emissions, 30MHz - 20GHz
	661	Figure 10-2	Conducted spurious emissions, 30MHz - 20GHz
	810	Figure 10-3	Conducted spurious emissions, 30MHz - 20GHz

Mode	CH	Location	Description
EDGE 850	128	Figure 11-1	Conducted spurious emissions, 30MHz - 20GHz
	190	Figure 11-2	Conducted spurious emissions, 30MHz - 20GHz
	251	Figure 11-3	Conducted spurious emissions, 30MHz - 20GHz
EDGE 1900	512	Figure 12-1	Conducted spurious emissions, 30MHz - 20GHz
	661	Figure 12-2	Conducted spurious emissions, 30MHz - 20GHz
	810	Figure 12-3	Conducted spurious emissions, 30MHz - 20GHz



Test Plot

GSM 850

Figure 7-1: Out of Band emission at antenna terminals – GSM CH Low

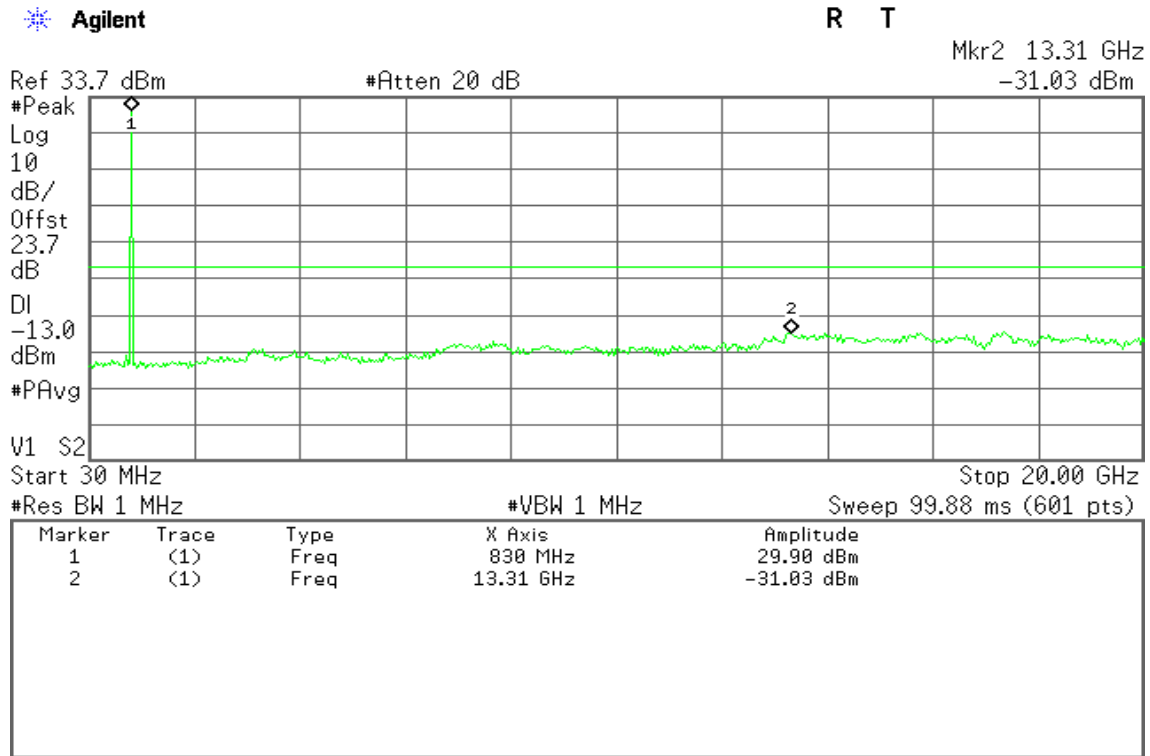

Figure 7-2: Out of Band emission at antenna terminals – GSM CH Mid

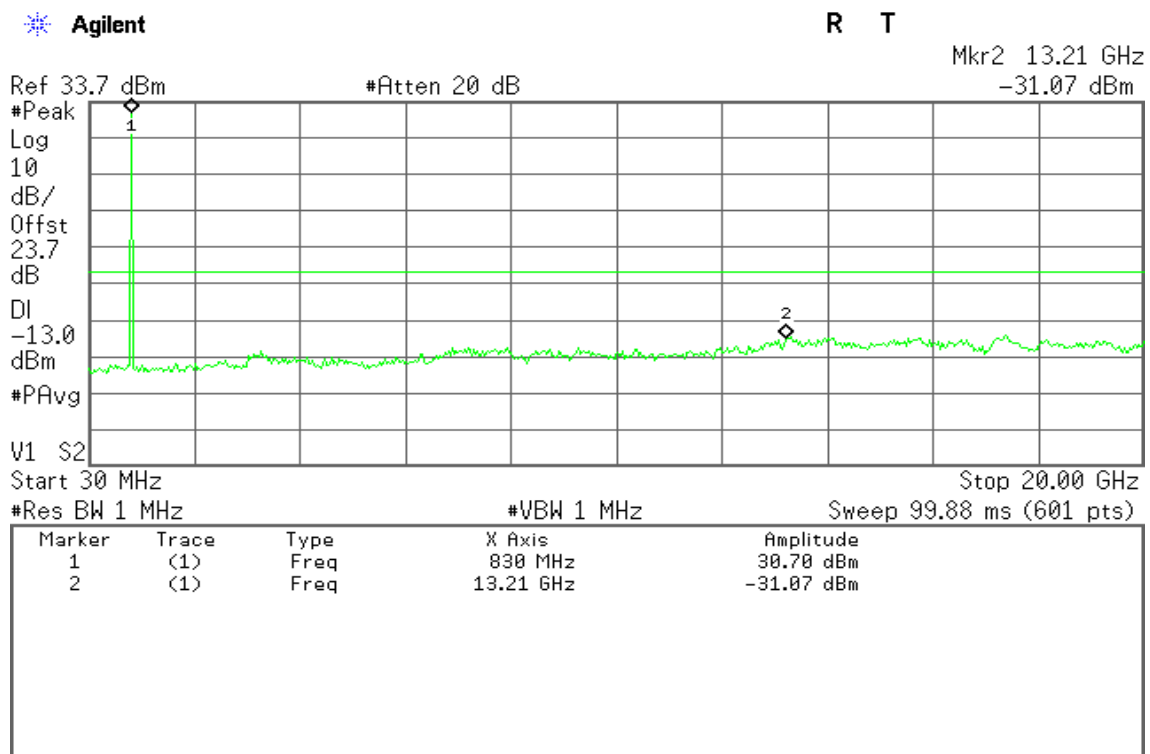
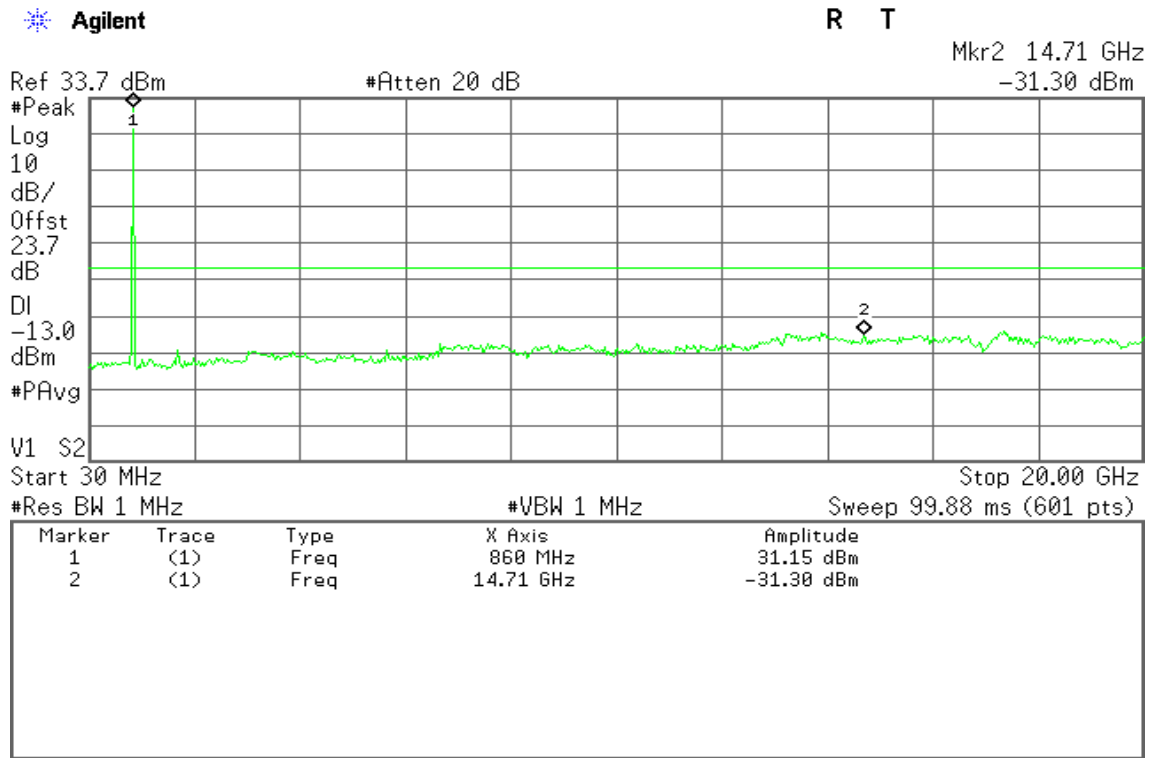



Figure 7-3: Out of Band emission at antenna terminals – GSM CH High



GPRS 850

Figure 8-1: Out of Band emission at antenna terminals – GPRS CH Low

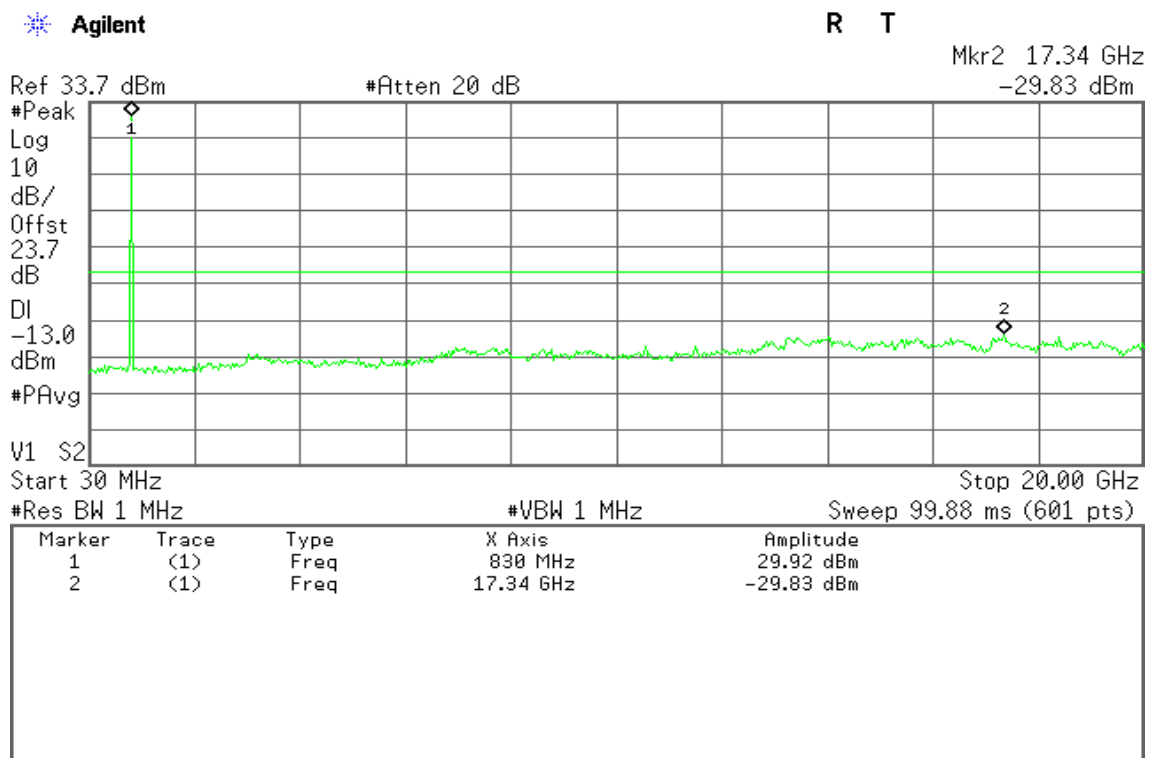



Figure 8-2: Out of Band emission at antenna terminals – GPRS CH Mid

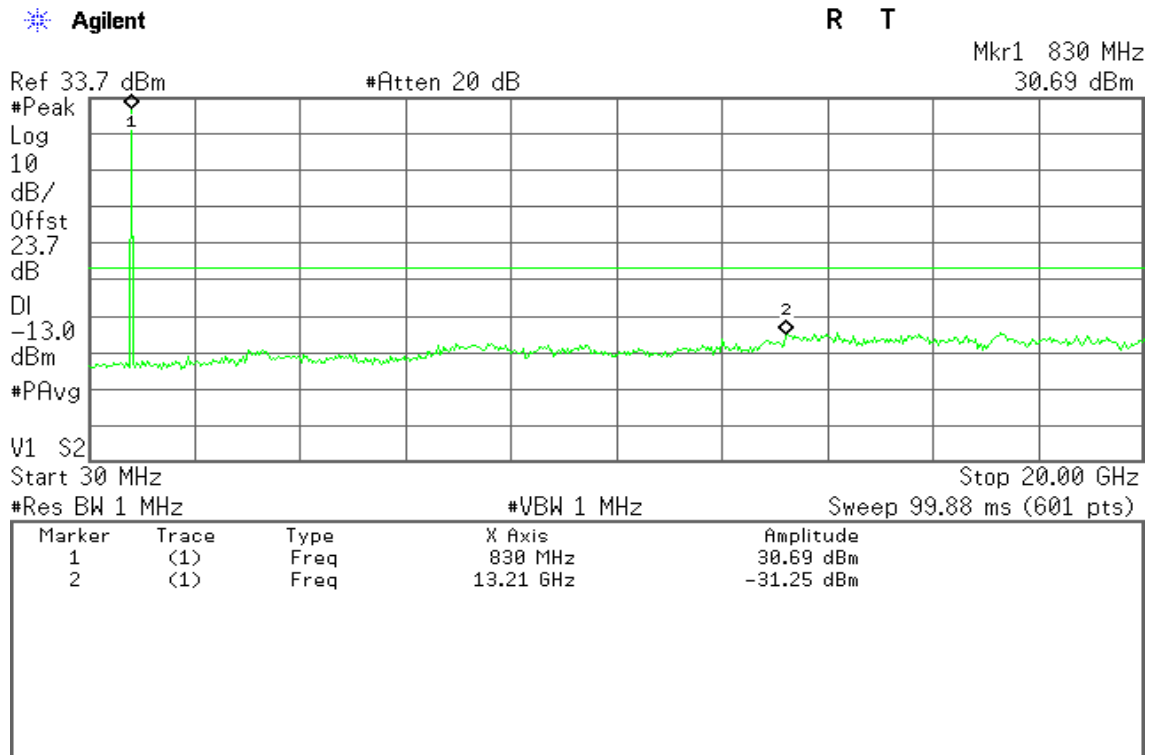
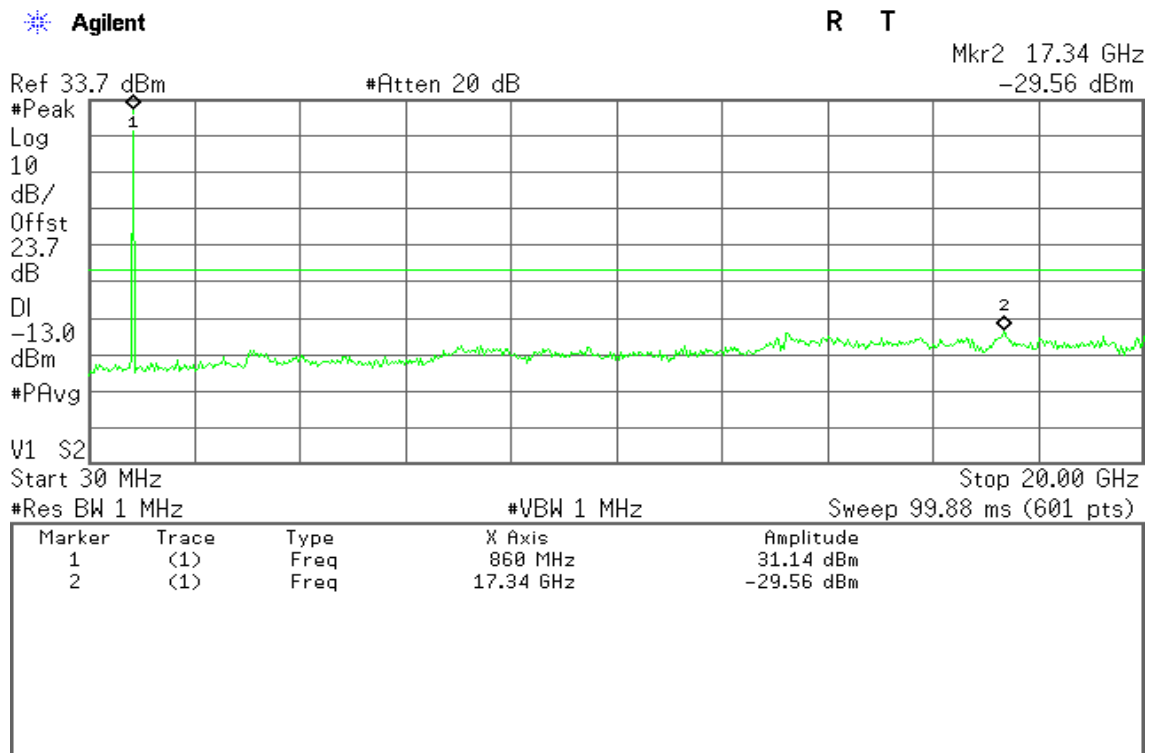

Figure 8-3: Out of Band emission at antenna terminals – GPRS CH High





GSM 1900

Figure 9-1: Out of Band emission at antenna terminals – GSM CH Low

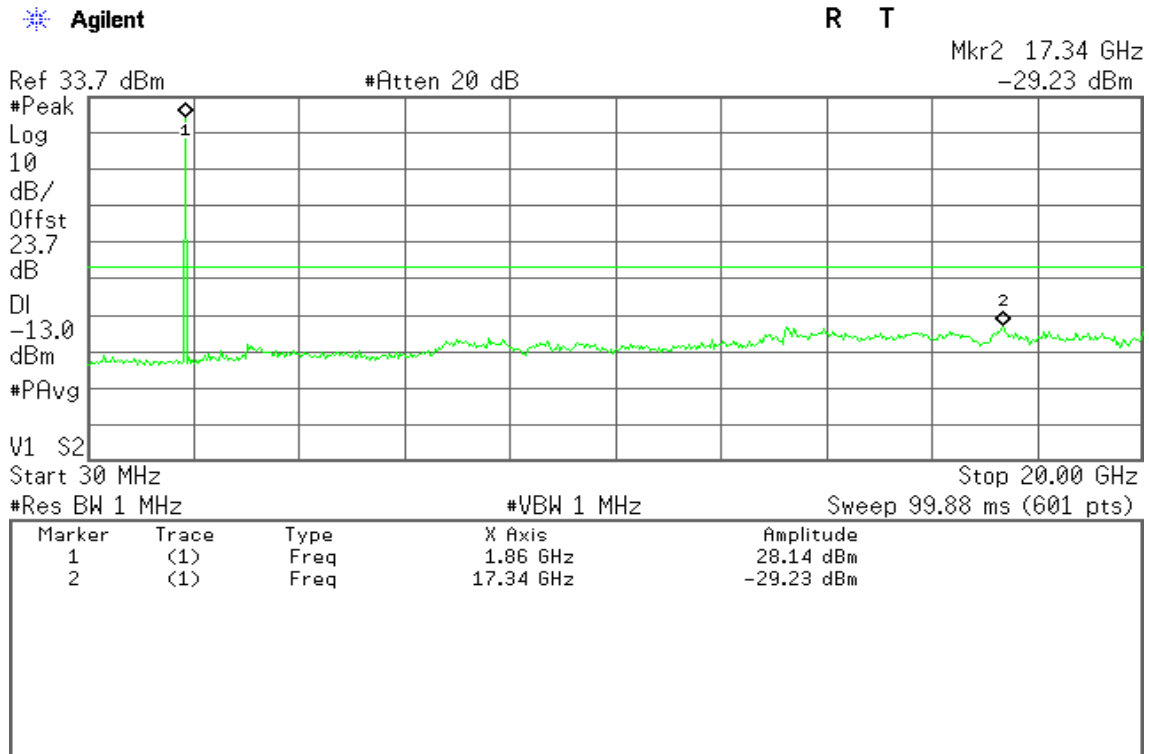

Figure 9-2: Out of Band emission at antenna terminals – GSM CH Mid

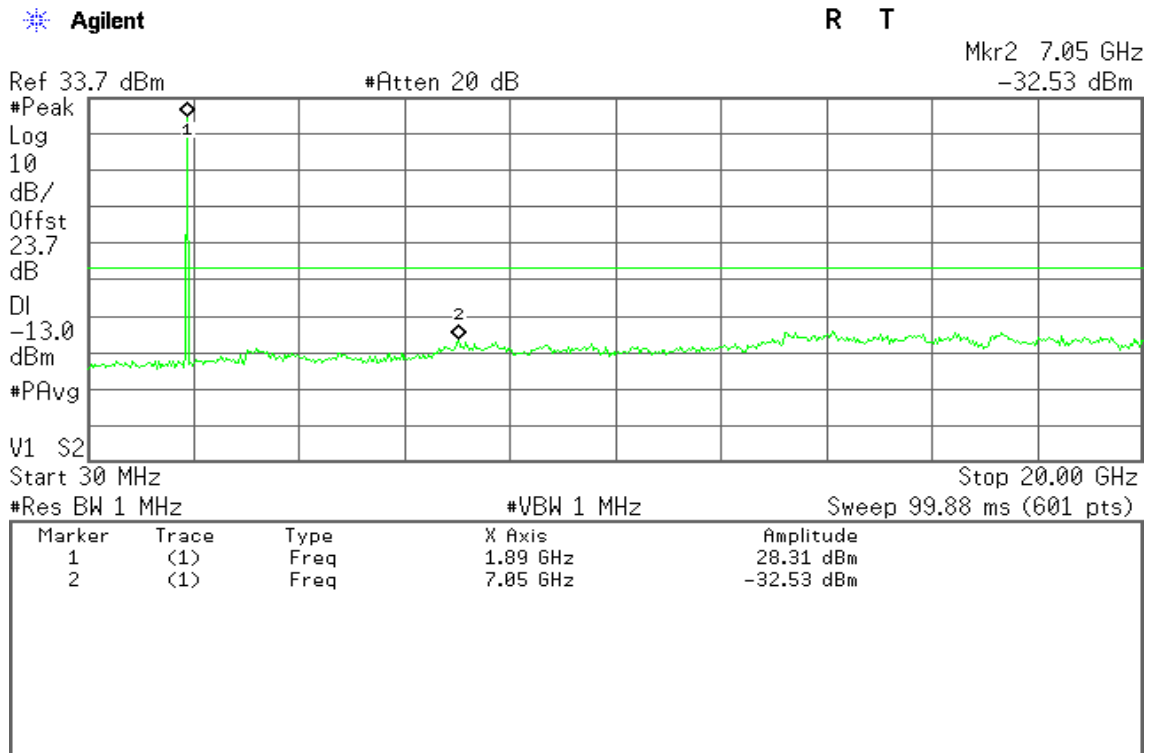
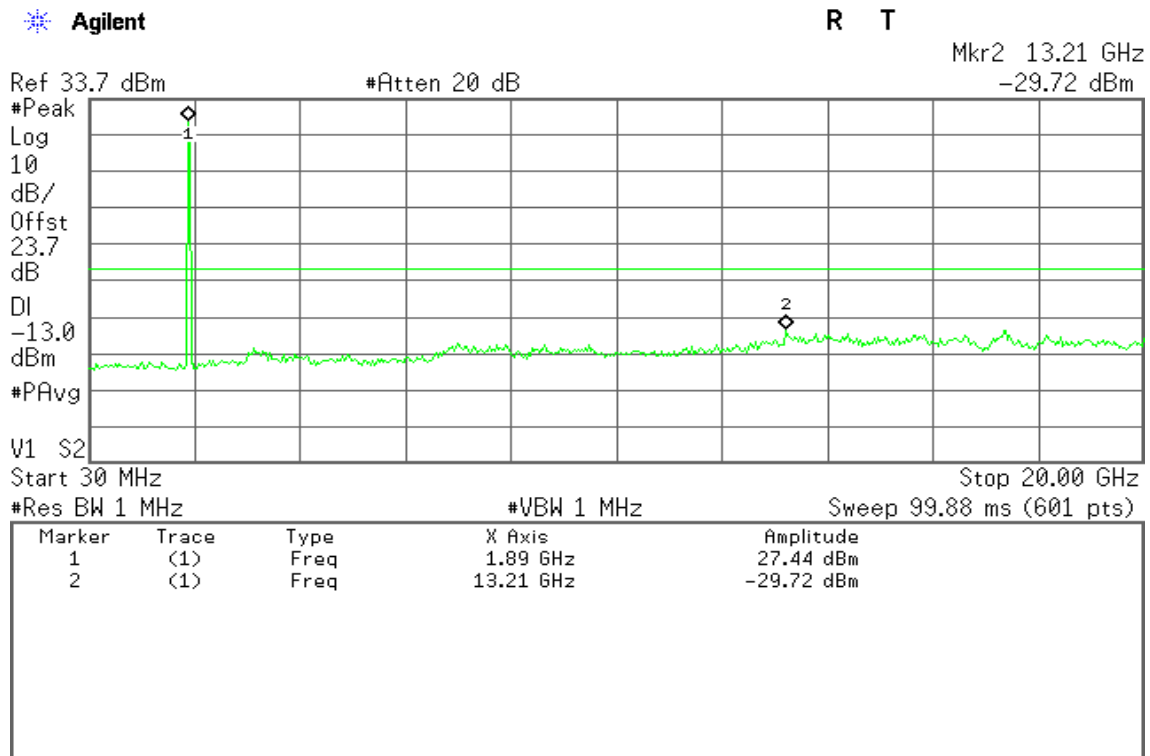



Figure 9-3: Out of Band emission at antenna terminals – GSM CH High



GPRS 1900

Figure 10-1: Out of Band emission at antenna terminals – GSM CH Low

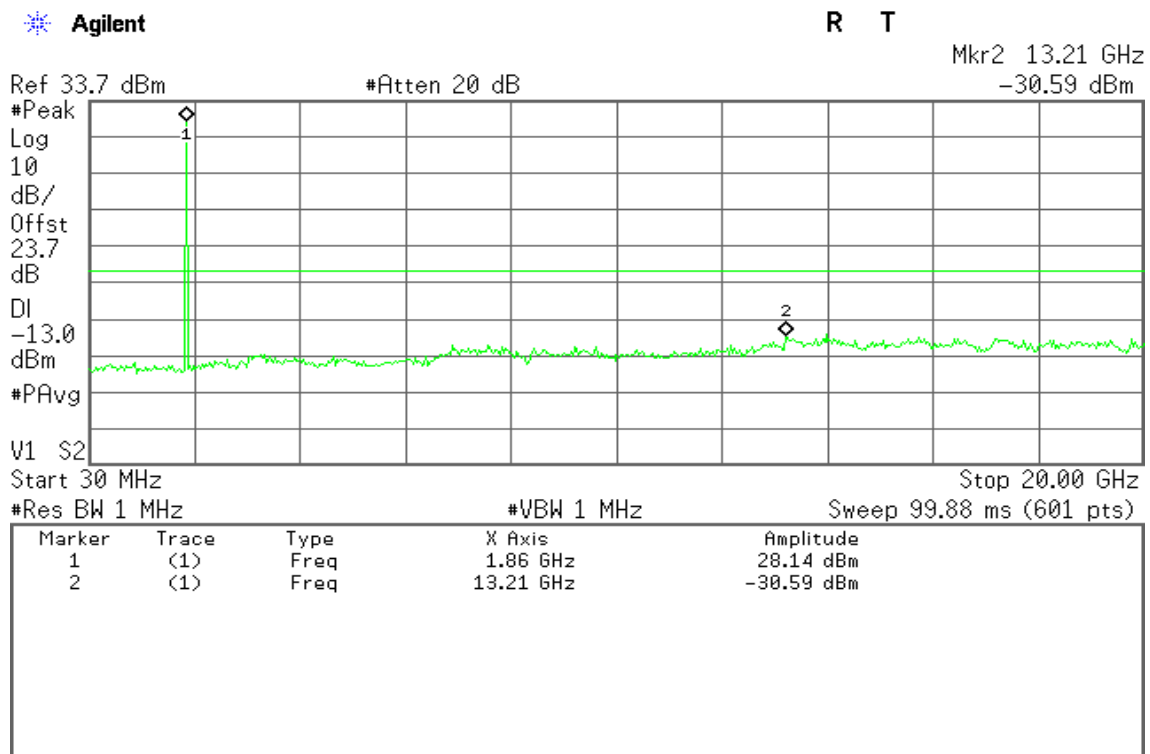



Figure 10-2: Out of Band emission at antenna terminals – GSM CH Mid

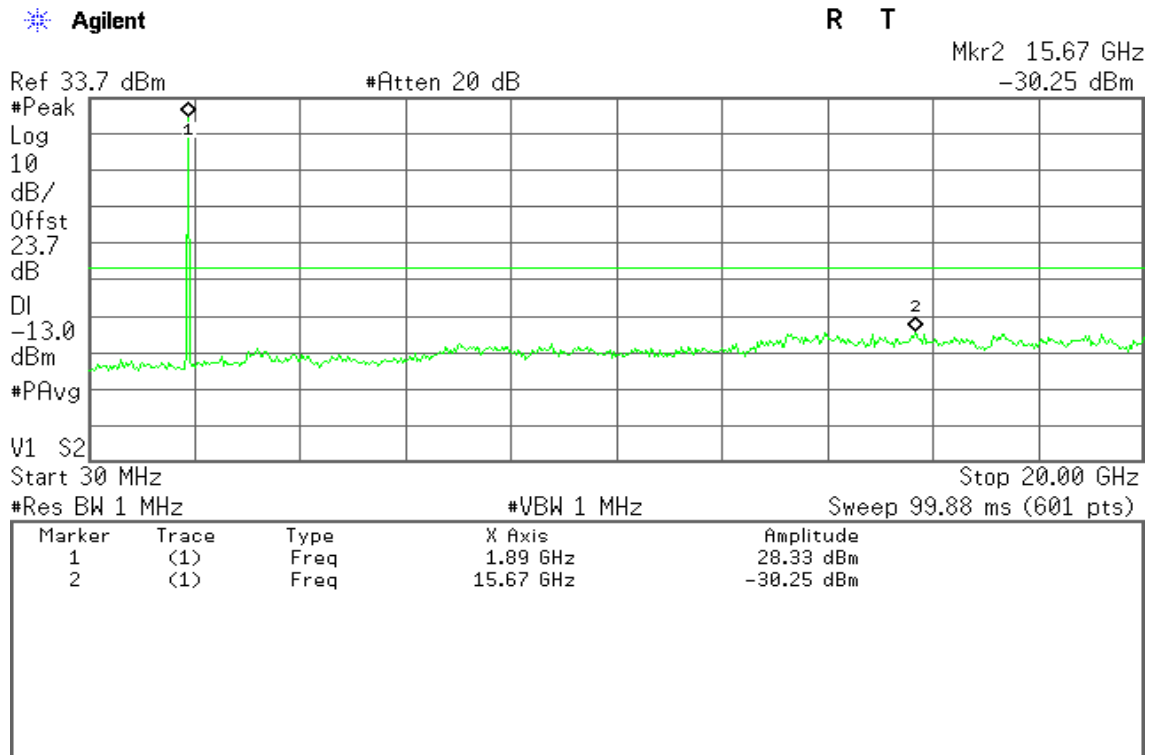
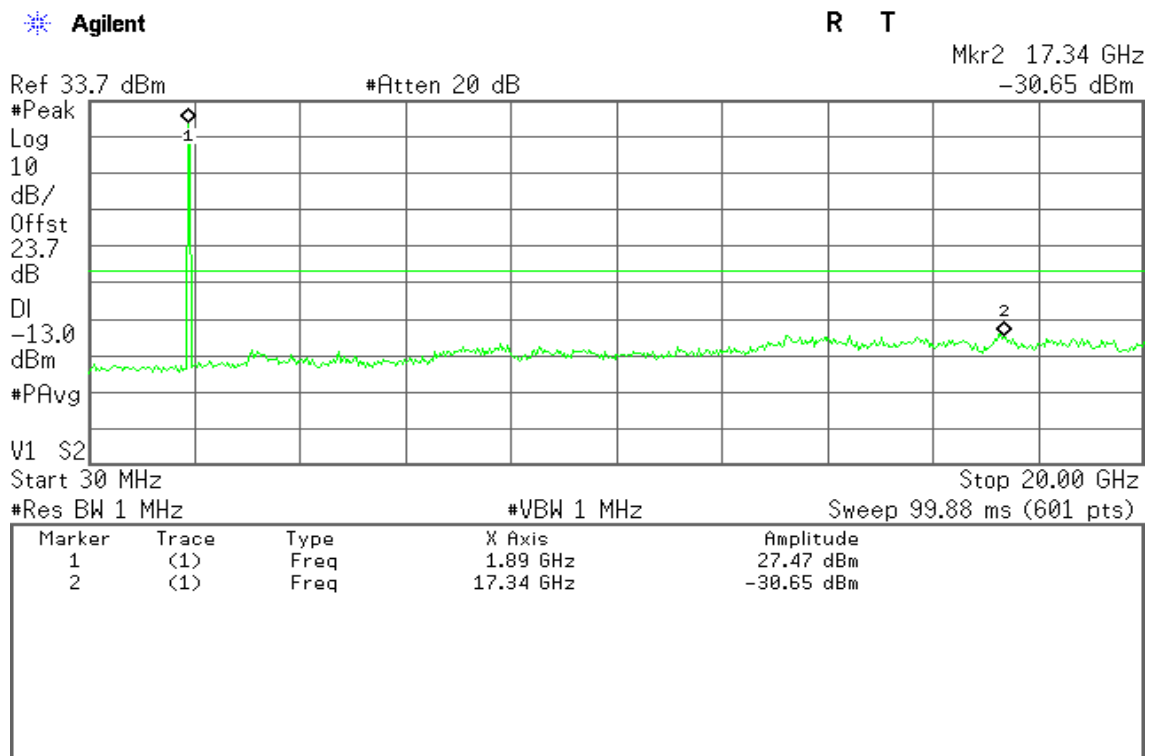

Figure 10-3: Out of Band emission at antenna terminals – GSM CH High





EDGE 850

Figure 11-1: Out of Band emission at antenna terminals –EDGE CH Low

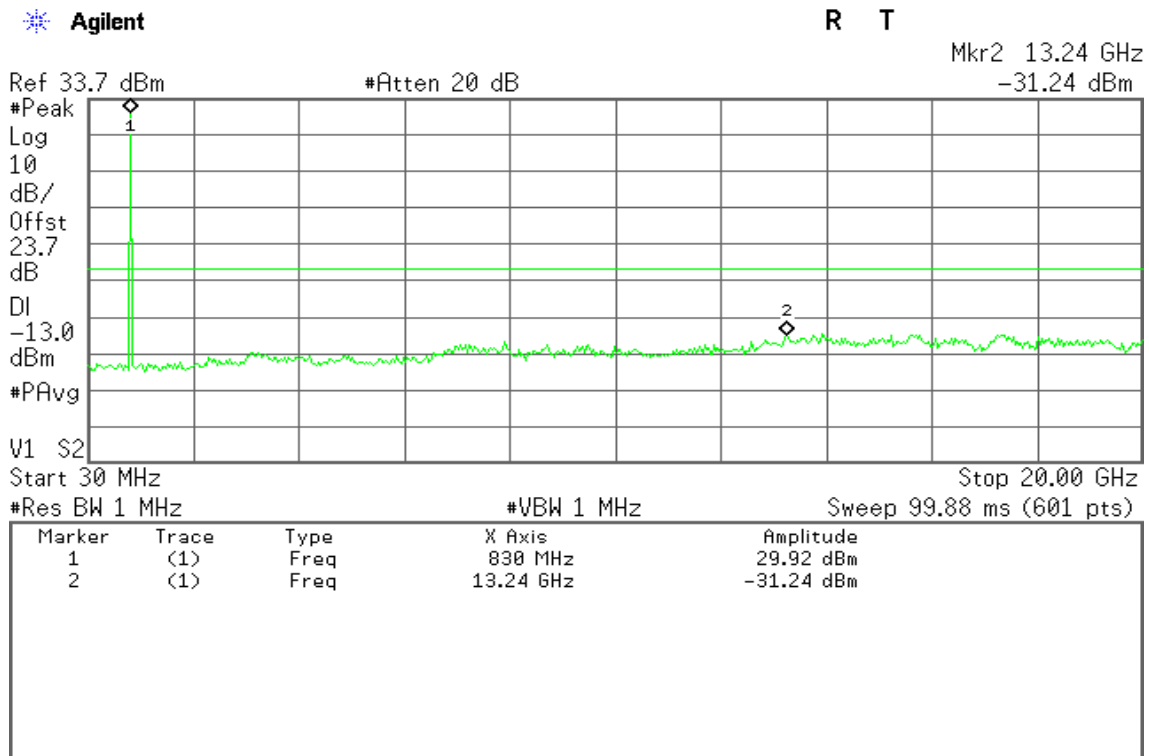

Figure 11-2: Out of Band emission at antenna terminals –EDGE CH Mid

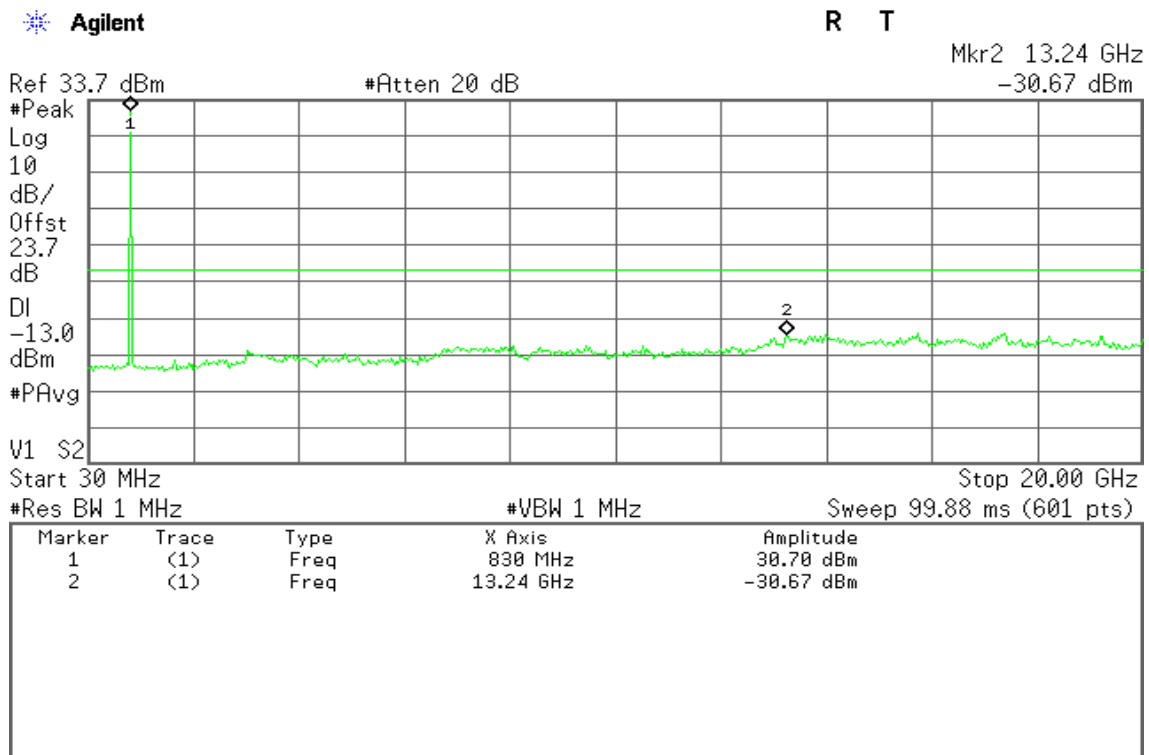
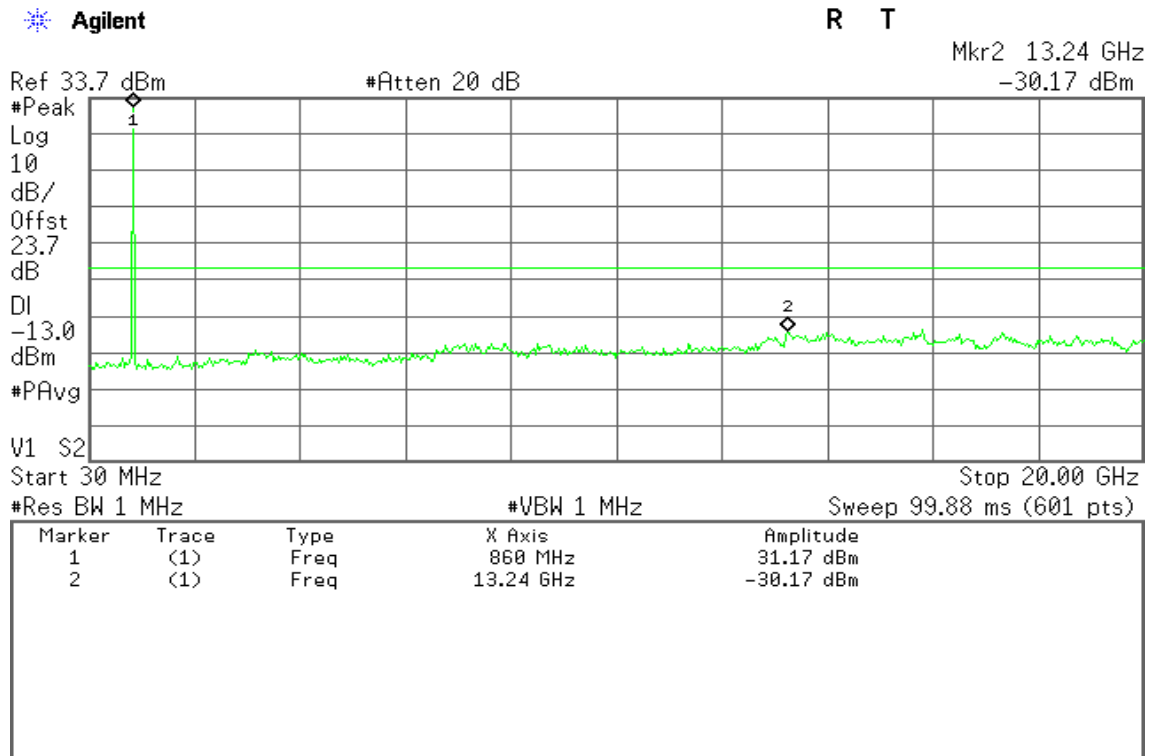



Figure 11-3: Out of Band emission at antenna terminals –EDGE CH High



EDGE 1900

Figure 12-1: Out of Band emission at antenna terminals –EDGE CH Low

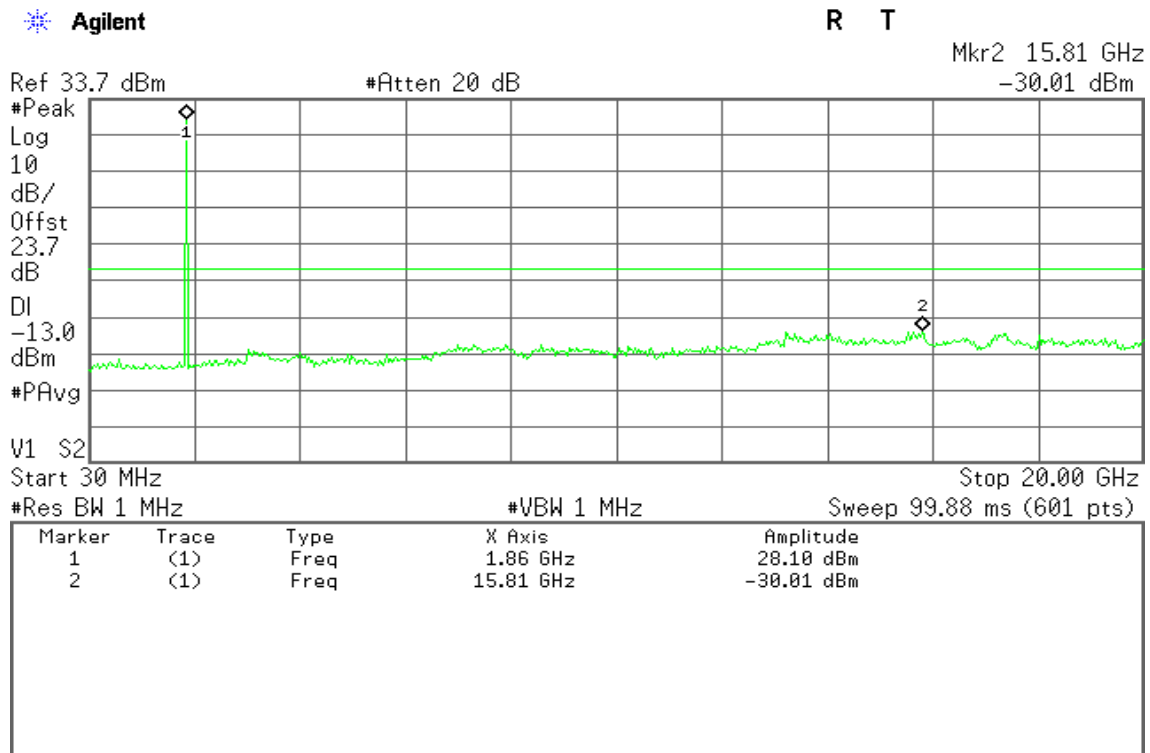



Figure 12-2: Out of Band emission at antenna terminals –EDGE CH Mid

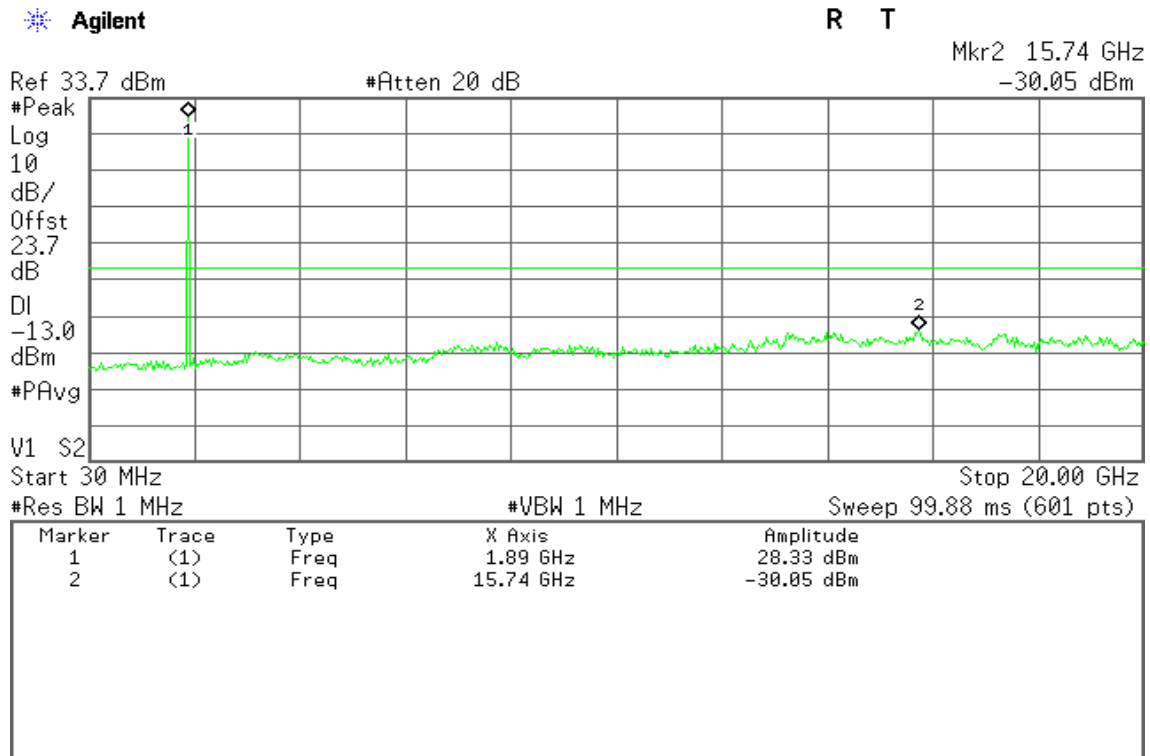
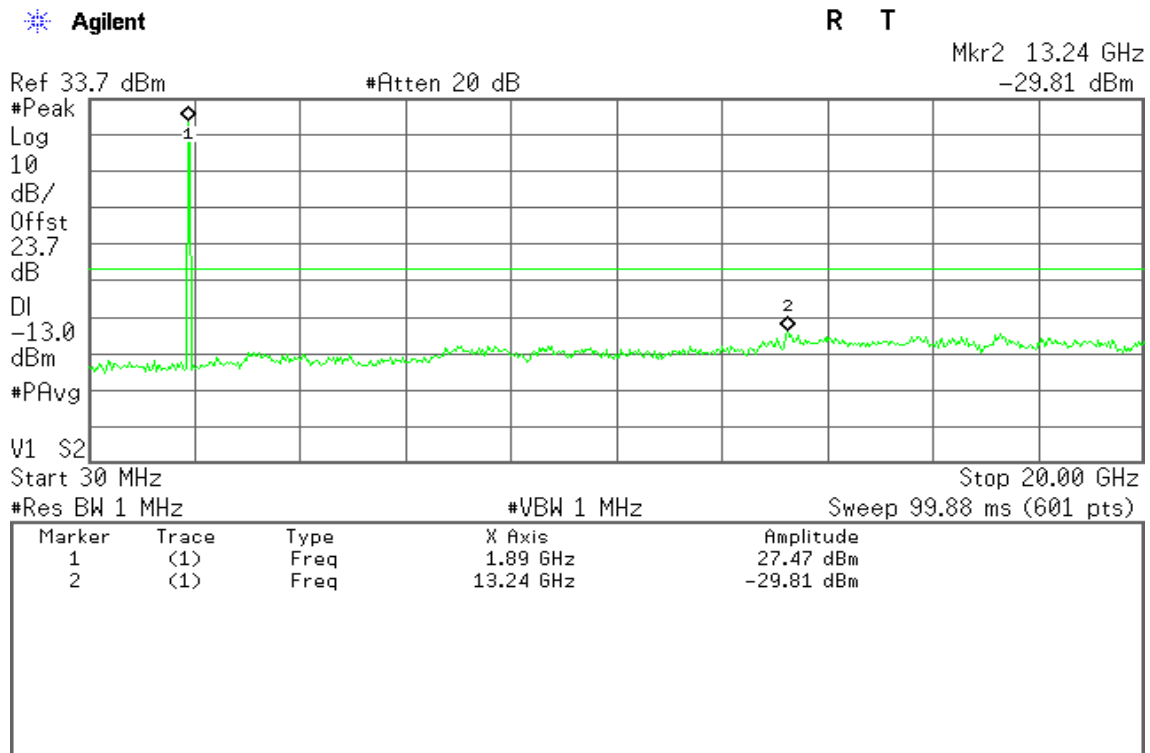

Figure 12-3: Out of Band emission at antenna terminals –EDGE CH High





7.5 FIELD STRENGTH OF SPURIOUS RADIATION MEASUREMENT

LIMIT

According to FCC §2.1053, RSS-132 (4.6) & RSS-133 (6.5).

Test Configuration

Below 1 GHz

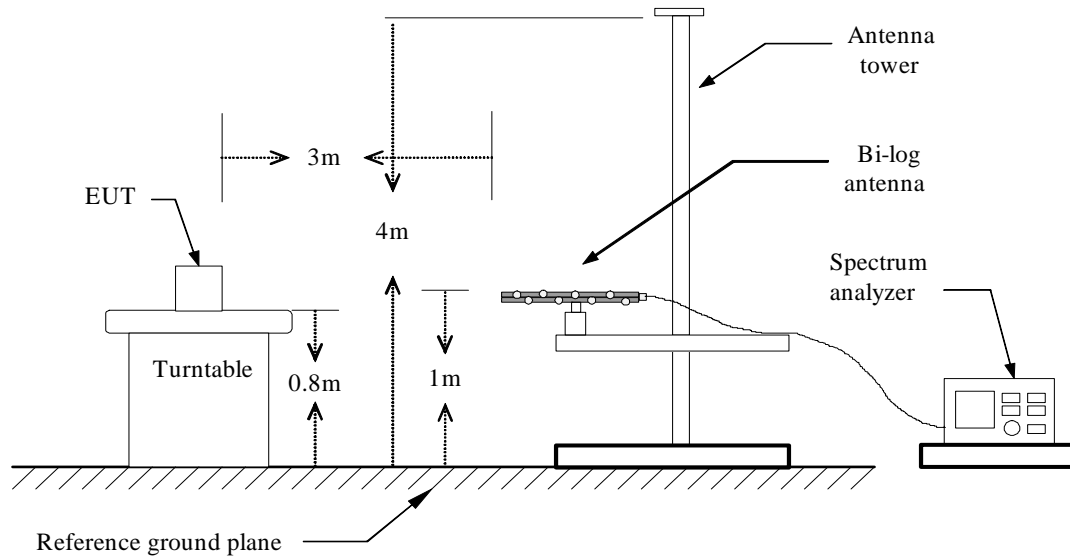

Above 1 GHz

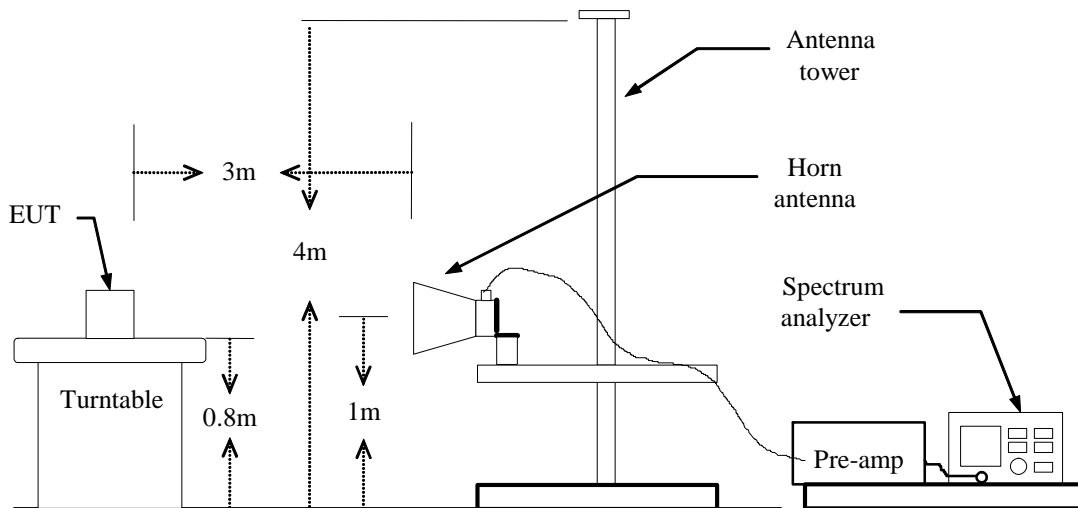



Substituted Method Test Set-up

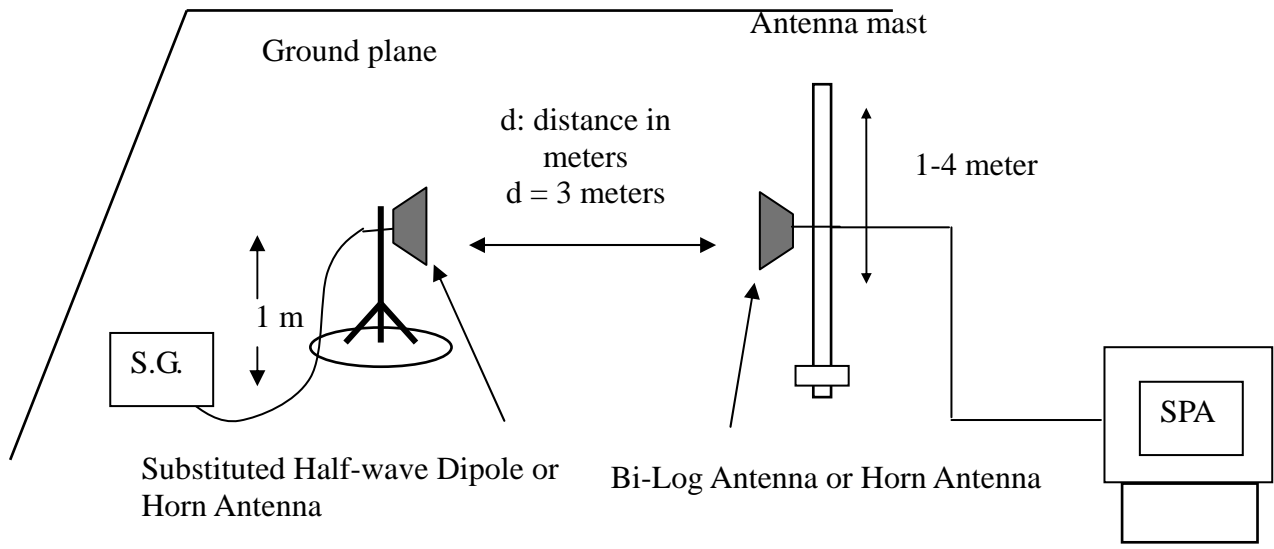

TEST PROCEDURE

The EUT was placed on a non-conductive, the measurement antenna was placed at a distance of 3 meters from the EUT. During the tests, the antenna height and the EUT azimuth were varied in order to identify the maximum level of emissions from the EUT. This maximization process was repeated with the EUT positioned in each of its three orthogonal orientations.

The frequency range up to tenth harmonic was investigated for each of three fundamental frequency (low, middle and high channels). Once spurious emission were identified, the power of the emission was determined using the substitution method.

The spurious emissions attenuation was calculated as the difference between radiated power at the fundamental frequency and the spurious emissions frequency.

$$\text{ERP} = \text{S.G. output (dBm)} + \text{Antenna Gain (dBd)} - \text{Cable (dB)}$$

$$\text{EIRP} = \text{S.G. output (dBm)} + \text{Antenna Gain (dBi)} - \text{Cable (dB)}$$

TEST RESULTS

Refer to the attached tabular data sheets.

**Radiated Spurious Emission Measurement Result / Below 1GHz****Operation Mode:** GSM 850 / TX / CH 128**Test Date:** January 20, 2014**Temperature:** 26°C**Tested by:** Wayne Tsai**Humidity:** 60 % RH**Polarity:** Ver. / Hor.

Frequency (MHz)	S.G. (dBm)	Cable loss (dB)	Ant.Gain (dBi)	Emission level (dBm)	Limit (dBm)	Margin (dB)	Antenna Polarization (V/H)
165.8000	-67.95	1.53	2.05	-67.43	-13.00	-54.43	V
232.7300	-72.41	1.8	5.39	-68.82	-13.00	-55.82	V
366.5900	-77.33	2.29	5.77	-73.85	-13.00	-60.85	V
499.4800	-75.59	2.7	5.89	-72.40	-13.00	-59.40	V
566.4100	-74.2	2.86	6.06	-71.00	-13.00	-58.00	V
630.4300	-78.09	2.98	6.19	-74.88	-13.00	-61.88	V
132.8200	-66.11	1.36	-1.07	-68.54	-13.00	-55.54	H
232.7300	-65.54	1.8	5.39	-61.95	-13.00	-48.95	H
299.6600	-66.34	2.09	5.59	-62.84	-13.00	-49.84	H
412.1800	-66.46	2.45	5.89	-63.02	-13.00	-50.02	H
500.4500	-71.26	2.7	5.9	-68.06	-13.00	-55.06	H
624.6100	-68.68	2.96	6.15	-65.49	-13.00	-52.49	H

Remark:

1. *The emission behaviour belongs to narrowband spurious emission.*
2. *Measurements above show only up to 6 maximum emissions noted, or would be lesser; with " N/A " remark, if no specific emissions from the EUT are recorded (ie: margin > 20dB from the applicable limit) and considered that's already beyond the background noise floor.*



Operation Mode: GSM 850 / TX / CH 190

Test Date: January 20, 2014

Temperature: 26°C

Tested by: Wayne Tsai

Humidity: 60 % RH

Polarity: Ver. / Hor.

Frequency (MHz)	S.G. (dBm)	Cable loss (dB)	Ant.Gain (dBi)	Emission level (dBm)	Limit (dBm)	Margin (dB)	Antenna Polarization (V/H)
165.8000	-63.38	1.53	2.05	-62.86	-13.00	-49.86	V
232.7300	-72.97	1.8	5.39	-69.38	-13.00	-56.38	V
366.5900	-78.4	2.29	5.77	-74.92	-13.00	-61.92	V
499.4800	-76.55	2.7	5.89	-73.36	-13.00	-60.36	V
564.4700	-73.37	2.86	6.03	-70.20	-13.00	-57.20	V
633.3400	-76.94	2.99	6.18	-73.75	-13.00	-60.75	V
132.8200	-65.72	1.36	-1.07	-68.15	-13.00	-55.15	H
232.7300	-65.71	1.8	5.39	-62.12	-13.00	-49.12	H
298.6900	-66.54	2.09	5.57	-63.06	-13.00	-50.06	H
412.1800	-66.46	2.45	5.89	-63.02	-13.00	-50.02	H
564.4700	-72.24	2.86	6.03	-69.07	-13.00	-56.07	H
624.6100	-68.97	2.96	6.15	-65.78	-13.00	-52.78	H

Remark:

1. *The emission behaviour belongs to narrowband spurious emission.*
2. *Measurements above show only up to 6 maximum emissions noted, or would be lesser, with " N/A " remark, if no specific emissions from the EUT are recorded (ie: margin>20dB from the applicable limit) and considered that's already beyond the background noise floor.*



Operation Mode: GSM 850 / TX / CH 251

Test Date: January 20, 2014

Temperature: 26°C

Tested by: Wayne Tsai

Humidity: 60 % RH

Polarity: Ver. / Hor.

Frequency (MHz)	S.G. (dBm)	Cable loss (dB)	Ant.Gain (dBi)	Emission level (dBm)	Limit (dBm)	Margin (dB)	Antenna Polarization (V/H)
165.8000	-67.35	1.53	2.05	-66.83	-13.00	-53.83	V
232.7300	-72.86	1.8	5.39	-69.27	-13.00	-56.27	V
299.6600	-77.96	2.09	5.59	-74.46	-13.00	-61.46	V
431.5800	-77.95	2.5	5.81	-74.64	-13.00	-61.64	V
564.4700	-73.22	2.86	6.03	-70.05	-13.00	-57.05	V
630.4300	-76.21	2.98	6.19	-73.00	-13.00	-60.00	V
165.8000	-66.26	1.53	2.05	-65.74	-13.00	-52.74	H
232.7300	-65.29	1.8	5.39	-61.70	-13.00	-48.70	H
298.6900	-66.4	2.09	5.57	-62.92	-13.00	-49.92	H
412.1800	-66.42	2.45	5.89	-62.98	-13.00	-49.98	H
564.4700	-72.55	2.86	6.03	-69.38	-13.00	-56.38	H
624.6100	-68.77	2.96	6.15	-65.58	-13.00	-52.58	H

Remark:

1. *The emission behaviour belongs to narrowband spurious emission.*
2. *Measurements above show only up to 6 maximum emissions noted, or would be lesser, with “ N/A ” remark, if no specific emissions from the EUT are recorded (ie: margin>20dB from the applicable limit) and considered that's already beyond the background noise floor.*



Operation Mode: GPRS 850 / TX / CH 128

Test Date: January 20, 2014

Temperature: 26°C

Tested by: Wayne Tsai

Humidity: 60 % RH

Polarity: Ver. / Hor.

Frequency (MHz)	S.G. (dBm)	Cable loss (dB)	Ant.Gain (dBi)	Emission level (dBm)	Limit (dBm)	Margin (dB)	Antenna Polarization (V/H)
166.7700	-67.99	1.54	2.15	-67.38	-13.00	-54.38	V
232.7300	-73.26	1.8	5.39	-69.67	-13.00	-56.67	V
366.5900	-77.6	2.29	5.77	-74.12	-13.00	-61.12	V
499.4800	-76.43	2.7	5.89	-73.24	-13.00	-60.24	V
566.4100	-73.66	2.86	6.06	-70.46	-13.00	-57.46	V
630.4300	-76.69	2.98	6.19	-73.48	-13.00	-60.48	V
132.8200	-64.93	1.36	-1.07	-67.36	-13.00	-54.36	H
232.7300	-64.89	1.8	5.39	-61.30	-13.00	-48.30	H
299.6600	-66.05	2.09	5.59	-62.55	-13.00	-49.55	H
412.1800	-65.83	2.45	5.89	-62.39	-13.00	-49.39	H
564.4700	-71	2.86	6.03	-67.83	-13.00	-54.83	H
624.6100	-68.24	2.96	6.15	-65.05	-13.00	-52.05	H

Remark:

1. *The emission behaviour belongs to narrowband spurious emission.*
2. *Measurements above show only up to 6 maximum emissions noted, or would be lesser, with " N/A " remark, if no specific emissions from the EUT are recorded (ie: margin>20dB from the applicable limit) and considered that's already beyond the background noise floor.*



Operation Mode: GPRS 850 / TX / CH 190

Test Date: January 20, 2014

Temperature: 26°C

Tested by: Wayne Tsai

Humidity: 60 % RH

Polarity: Ver. / Hor.

Frequency (MHz)	S.G. (dBm)	Cable loss (dB)	Ant.Gain (dBi)	Emission level (dBm)	Limit (dBm)	Margin (dB)	Antenna Polarization (V/H)
165.8000	-67.83	1.53	2.05	-67.31	-13.00	-54.31	V
232.7300	-73.24	1.8	5.39	-69.65	-13.00	-56.65	V
412.1800	-77.48	2.45	5.89	-74.04	-13.00	-61.04	V
499.4800	-75.68	2.7	5.89	-72.49	-13.00	-59.49	V
564.4700	-73.42	2.86	6.03	-70.25	-13.00	-57.25	V
630.4300	-76.52	2.98	6.19	-73.31	-13.00	-60.31	V
132.8200	-65.4	1.36	-1.07	-67.83	-13.00	-54.83	H
232.7300	-65.1	1.8	5.39	-61.51	-13.00	-48.51	H
299.6600	-66.32	2.09	5.59	-62.82	-13.00	-49.82	H
412.1800	-66.25	2.45	5.89	-62.81	-13.00	-49.81	H
564.4700	-72.71	2.86	6.03	-69.54	-13.00	-56.54	H
624.6100	-68.64	2.96	6.15	-65.45	-13.00	-52.45	H

Remark:

1. *The emission behaviour belongs to narrowband spurious emission.*
2. *Measurements above show only up to 6 maximum emissions noted, or would be lesser, with “ N/A ” remark, if no specific emissions from the EUT are recorded (ie: margin>20dB from the applicable limit) and considered that's already beyond the background noise floor.*



Operation Mode: GPRS 850 / TX / CH 251

Test Date: January 20, 2014

Temperature: 26°C

Tested by: Wayne Tsai

Humidity: 60 % RH

Polarity: Ver. / Hor.

Frequency (MHz)	S.G. (dBm)	Cable loss (dB)	Ant.Gain (dBi)	Emission level (dBm)	Limit (dBm)	Margin (dB)	Antenna Polarization (V/H)
166.7700	-68.5	1.54	2.15	-67.89	-13.00	-54.89	V
232.7300	-72.77	1.8	5.39	-69.18	-13.00	-56.18	V
299.6600	-79.37	2.09	5.59	-75.87	-13.00	-62.87	V
431.5800	-77.8	2.5	5.81	-74.49	-13.00	-61.49	V
566.4100	-73.89	2.86	6.06	-70.69	-13.00	-57.69	V
630.4300	-76.98	2.98	6.19	-73.77	-13.00	-60.77	V
132.8200	-65.56	1.36	-1.07	-67.99	-13.00	-54.99	H
232.7300	-65.36	1.8	5.39	-61.77	-13.00	-48.77	H
299.6600	-66.24	2.09	5.59	-62.74	-13.00	-49.74	H
412.1800	-66.49	2.45	5.89	-63.05	-13.00	-50.05	H
500.4500	-71.25	2.7	5.9	-68.05	-13.00	-55.05	H
624.6100	-69.18	2.96	6.15	-65.99	-13.00	-52.99	H

Remark:

1. The emission behaviour belongs to narrowband spurious emission.
2. Measurements above show only up to 6 maximum emissions noted, or would be lesser, with " N/A " remark, if no specific emissions from the EUT are recorded (ie: margin>20dB from the applicable limit) and considered that's already beyond the background noise floor.



Operation Mode: GSM 1900 / TX / CH 512

Test Date: January 20, 2014

Temperature: 26°C

Tested by: Wayne Tsai

Humidity: 60 % RH

Polarity: Ver. / Hor.

Frequency (MHz)	S.G. (dBm)	Cable loss (dB)	Ant.Gain (dBi)	Emission level (dBm)	Limit (dBm)	Margin (dB)	Antenna Polarization (V/H)
40.6700	-56.44	0.73	-11.85	-69.02	-13.00	-56.02	V
129.9100	-69.53	1.34	-1.41	-72.28	-13.00	-59.28	V
181.3200	-81.11	1.61	3.66	-79.06	-13.00	-66.06	V
307.4200	-84.97	2.12	5.75	-81.34	-13.00	-68.34	V
449.0400	-83.07	2.59	5.72	-79.94	-13.00	-66.94	V
574.1700	-81.92	2.88	6.07	-78.73	-13.00	-65.73	V
55.2200	-62.95	0.84	-3.37	-67.16	-13.00	-54.16	H
127.9700	-68.94	1.33	-1.56	-71.83	-13.00	-58.83	H
184.2300	-75.29	1.61	3.77	-73.13	-13.00	-60.13	H
245.3400	-77.6	1.82	5.5	-73.92	-13.00	-60.92	H
473.2900	-78.91	2.62	5.7	-75.83	-13.00	-62.83	H
642.0700	-76.87	3.01	6.14	-73.74	-13.00	-60.74	H

Remark:

1. *Measuring frequencies from 1 GHz to the 10th harmonic of highest fundamental frequency.*
2. *Measurements above show only up to 6 maximum emissions noted, or would be lesser; with " N/A " remark, if no specific emissions from the EUT are recorded (ie: margin>20dB from the applicable limit) and considered that's already beyond the background noise floor.*



Operation Mode: GSM 1900 / TX / CH 661

Test Date: January 20, 2014

Temperature: 26°C

Tested by: Wayne Tsai

Humidity: 60 % RH

Polarity: Ver. / Hor.

Frequency (MHz)	S.G. (dBm)	Cable loss (dB)	Ant.Gain (dBi)	Emission level (dBm)	Limit (dBm)	Margin (dB)	Antenna Polarization (V/H)
39.7000	-57.81	0.72	-12.6	-71.13	-13.00	-58.13	V
130.8800	-71.56	1.35	-1.3	-74.21	-13.00	-61.21	V
245.3400	-85.38	1.82	5.5	-81.70	-13.00	-68.70	V
379.2000	-85.38	2.31	5.98	-81.71	-13.00	-68.71	V
575.1400	-82.92	2.88	6.06	-79.74	-13.00	-66.74	V
709.0000	-81.2	3.14	6.3	-78.04	-13.00	-65.04	V
54.2500	-64.27	0.83	-3.66	-68.76	-13.00	-55.76	H
129.9100	-69	1.34	-1.41	-71.75	-13.00	-58.75	H
184.2300	-76.04	1.61	3.77	-73.88	-13.00	-60.88	H
307.4200	-79.21	2.12	5.75	-75.58	-13.00	-62.58	H
472.3200	-78.55	2.62	5.72	-75.45	-13.00	-62.45	H
619.7600	-78.12	2.94	6.11	-74.95	-13.00	-61.95	H

Remark:

1. Measuring frequencies from 1 GHz to the 10th harmonic of highest fundamental frequency.
2. Measurements above show only up to 6 maximum emissions noted, or would be lesser; with " N/A " remark, if no specific emissions from the EUT are recorded (ie: margin > 20dB from the applicable limit) and considered that's already beyond the background noise floor.



Operation Mode: GSM 1900 / TX / CH 810

Test Date: January 20, 2014

Temperature: 26°C

Tested by: Wayne Tsai

Humidity: 60 % RH

Polarity: Ver. / Hor.

Frequency (MHz)	S.G. (dBm)	Cable loss (dB)	Ant.Gain (dBi)	Emission level (dBm)	Limit (dBm)	Margin (dB)	Antenna Polarization (V/H)
39.7000	-57.56	0.72	-12.6	-70.88	-13.00	-57.88	V
134.7600	-71.46	1.37	-0.84	-73.67	-13.00	-60.67	V
249.2200	-85.25	1.84	5.65	-81.44	-13.00	-68.44	V
414.1200	-84.96	2.45	5.87	-81.54	-13.00	-68.54	V
540.2200	-83.3	2.78	6.26	-79.82	-13.00	-66.82	V
770.1100	-80.45	3.27	6.38	-77.34	-13.00	-64.34	V
55.2200	-64.31	0.84	-3.37	-68.52	-13.00	-55.52	H
130.8800	-70.04	1.35	-1.3	-72.69	-13.00	-59.69	H
245.3400	-78.91	1.82	5.5	-75.23	-13.00	-62.23	H
307.4200	-77.51	2.12	5.75	-73.88	-13.00	-60.88	H
527.6100	-80.81	2.74	6.02	-77.53	-13.00	-64.53	H
687.6600	-77.66	3.12	6.5	-74.28	-13.00	-61.28	H

Remark:

1. *Measuring frequencies from 1 GHz to the 10th harmonic of highest fundamental frequency.*
2. *Measurements above show only up to 6 maximum emissions noted, or would be lesser; with " N/A " remark, if no specific emissions from the EUT are recorded (ie: margin > 20dB from the applicable limit) and considered that's already beyond the background noise floor.*



Operation Mode: GPRS 1900 / TX / CH 512

Test Date: January 20, 2014

Temperature: 26°C

Tested by: Wayne Tsai

Humidity: 60 % RH

Polarity: Ver. / Hor.

Frequency (MHz)	S.G. (dBm)	Cable loss (dB)	Ant.Gain (dBi)	Emission level (dBm)	Limit (dBm)	Margin (dB)	Antenna Polarization (V/H)
39.7000	-58.21	0.72	-12.6	-71.53	-13.00	-58.53	V
135.7300	-72.14	1.37	-0.72	-74.23	-13.00	-61.23	V
245.3400	-85.99	1.82	5.5	-82.31	-13.00	-69.31	V
414.1200	-85.89	2.45	5.87	-82.47	-13.00	-69.47	V
447.1000	-84.57	2.58	5.76	-81.39	-13.00	-68.39	V
697.3600	-81.54	3.11	6.42	-78.23	-13.00	-65.23	V
54.2500	-64.12	0.83	-3.66	-68.61	-13.00	-55.61	H
128.9400	-69.81	1.34	-1.5	-72.65	-13.00	-59.65	H
184.2300	-78.03	1.61	3.77	-75.87	-13.00	-62.87	H
245.3400	-79.99	1.82	5.5	-76.31	-13.00	-63.31	H
307.4200	-81.59	2.12	5.75	-77.96	-13.00	-64.96	H
493.6600	-80.68	2.68	5.83	-77.53	-13.00	-64.53	H

Remark:

1. *Measuring frequencies from 1 GHz to the 10th harmonic of highest fundamental frequency.*
2. *Measurements above show only up to 6 maximum emissions noted, or would be lesser; with " N/A " remark, if no specific emissions from the EUT are recorded (ie: margin>20dB from the applicable limit) and considered that's already beyond the background noise floor.*



Operation Mode: GPRS 1900 / TX / CH 661

Test Date: January 20, 2014

Temperature: 26°C

Tested by: Wayne Tsai

Humidity: 60 % RH

Polarity: Ver. / Hor.

Frequency (MHz)	S.G. (dBm)	Cable loss (dB)	Ant.Gain (dBi)	Emission level (dBm)	Limit (dBm)	Margin (dB)	Antenna Polarization (V/H)
39.7000	-58.13	0.72	-12.6	-71.45	-13.00	-58.45	V
131.8500	-72.35	1.35	-1.18	-74.88	-13.00	-61.88	V
249.2200	-87.08	1.84	5.65	-83.27	-13.00	-70.27	V
440.3100	-85.17	2.53	5.89	-81.81	-13.00	-68.81	V
630.4300	-82.94	2.98	6.19	-79.73	-13.00	-66.73	V
818.6100	-80.13	3.38	6.2	-77.31	-13.00	-64.31	V
55.2200	-64.41	0.84	-3.37	-68.62	-13.00	-55.62	H
184.2300	-74.18	1.61	3.77	-72.02	-13.00	-59.02	H
249.2200	-79.2	1.84	5.65	-75.39	-13.00	-62.39	H
415.0900	-80.79	2.45	5.86	-77.38	-13.00	-64.38	H
500.4500	-79.86	2.7	5.9	-76.66	-13.00	-63.66	H
633.3400	-78.14	2.99	6.18	-74.95	-13.00	-61.95	H

Remark:

1. *Measuring frequencies from 1 GHz to the 10th harmonic of highest fundamental frequency.*
2. *Measurements above show only up to 6 maximum emissions noted, or would be lesser; with " N/A " remark, if no specific emissions from the EUT are recorded (ie: margin>20dB from the applicable limit) and considered that's already beyond the background noise floor.*



Operation Mode: GPRS 1900 / TX / CH 810

Test Date: January 20, 2014

Temperature: 26°C

Tested by: Wayne Tsai

Humidity: 60 % RH

Polarity: Ver. / Hor.

Frequency (MHz)	S.G. (dBm)	Cable loss (dB)	Ant.Gain (dBi)	Emission level (dBm)	Limit (dBm)	Margin (dB)	Antenna Polarization (V/H)
39.7000	-58.36	0.72	-12.6	-71.68	-13.00	-58.68	V
131.8500	-72.01	1.35	-1.18	-74.54	-13.00	-61.54	V
184.2300	-82.02	1.61	3.77	-79.86	-13.00	-66.86	V
309.3600	-86.88	2.13	5.78	-83.23	-13.00	-70.23	V
437.4000	-83.74	2.52	5.88	-80.38	-13.00	-67.38	V
619.7600	-82.71	2.94	6.11	-79.54	-13.00	-66.54	V
55.2200	-64.48	0.84	-3.37	-68.69	-13.00	-55.69	H
127.9700	-70.5	1.33	-1.56	-73.39	-13.00	-60.39	H
184.2300	-76.78	1.61	3.77	-74.62	-13.00	-61.62	H
326.8200	-81.21	2.17	5.71	-77.67	-13.00	-64.67	H
475.2300	-79.68	2.63	5.65	-76.66	-13.00	-63.66	H
640.1300	-78.2	3.01	6.13	-75.08	-13.00	-62.08	H

Remark:

1. *Measuring frequencies from 1 GHz to the 10th harmonic of highest fundamental frequency.*
2. *Measurements above show only up to 6 maximum emissions noted, or would be lesser, with " N/A " remark, if no specific emissions from the EUT are recorded (ie: margin>20dB from the applicable limit) and considered that's already beyond the background noise floor.*



Operation Mode: EDGE 850 / TX / CH 128

Test Date: January 20, 2014

Temperature: 26°C

Tested by: Wayne Tsai

Humidity: 60 % RH

Polarity: Ver. / Hor.

Frequency (MHz)	S.G. (dBm)	Cable loss (dB)	Ant.Gain (dBi)	Emission level (dBm)	Limit (dBm)	Margin (dB)	Antenna Polarization (V/H)
165.8000	-67.26	1.53	2.05	-66.74	-13.00	-53.74	V
232.7300	-73.17	1.8	5.39	-69.58	-13.00	-56.58	V
299.6600	-78.48	2.09	5.59	-74.98	-13.00	-61.98	V
497.5400	-75.76	2.69	5.87	-72.58	-13.00	-59.58	V
564.4700	-73.75	2.86	6.03	-70.58	-13.00	-57.58	V
633.3400	-76.36	2.99	6.18	-73.17	-13.00	-60.17	V
132.8200	-64.95	1.36	-1.07	-67.38	-13.00	-54.38	H
232.7300	-64.59	1.8	5.39	-61.00	-13.00	-48.00	H
298.6900	-65.87	2.09	5.57	-62.39	-13.00	-49.39	H
412.1800	-66.26	2.45	5.89	-62.82	-13.00	-49.82	H
564.4700	-71.99	2.86	6.03	-68.82	-13.00	-55.82	H
624.6100	-68.41	2.96	6.15	-65.22	-13.00	-52.22	H

Remark:

1. Measuring frequencies from 1 GHz to the 10th harmonic of highest fundamental frequency.
2. Measurements above show only up to 6 maximum emissions noted, or would be lesser; with " N/A " remark, if no specific emissions from the EUT are recorded (ie: margin>20dB from the applicable limit) and considered that's already beyond the background noise floor.



Operation Mode: EDGE 850 / TX / CH 190

Test Date: January 20, 2014

Temperature: 26°C

Tested by: Wayne Tsai

Humidity: 60 % RH

Polarity: Ver. / Hor.

Frequency (MHz)	S.G. (dBm)	Cable loss (dB)	Ant.Gain (dBi)	Emission level (dBm)	Limit (dBm)	Margin (dB)	Antenna Polarization (V/H)
165.8000	-67.7	1.53	2.05	-67.18	-13.00	-54.18	V
232.7300	-72.03	1.8	5.39	-68.44	-13.00	-55.44	V
364.6500	-79.09	2.28	5.75	-75.62	-13.00	-62.62	V
497.5400	-75.83	2.69	5.87	-72.65	-13.00	-59.65	V
566.4100	-72.97	2.86	6.06	-69.77	-13.00	-56.77	V
633.3400	-77.15	2.99	6.18	-73.96	-13.00	-60.96	V
132.8200	-64.81	1.36	-1.07	-67.24	-13.00	-54.24	H
232.7300	-64.29	1.8	5.39	-60.70	-13.00	-47.70	H
299.6600	-65.71	2.09	5.59	-62.21	-13.00	-49.21	H
412.1800	-65.72	2.45	5.89	-62.28	-13.00	-49.28	H
500.4500	-70.08	2.7	5.9	-66.88	-13.00	-53.88	H
624.6100	-67.73	2.96	6.15	-64.54	-13.00	-51.54	H

Remark:

1. Measuring frequencies from 1 GHz to the 10th harmonic of highest fundamental frequency.
2. Measurements above show only up to 6 maximum emissions noted, or would be lesser; with " N/A " remark, if no specific emissions from the EUT are recorded (ie: margin>20dB from the applicable limit) and considered that's already beyond the background noise floor.



Operation Mode: EDGE 850 / TX / CH 251

Test Date: January 20, 2014

Temperature: 26°C

Tested by: Wayne Tsai

Humidity: 60 % RH

Polarity: Ver. / Hor.

Frequency (MHz)	S.G. (dBm)	Cable loss (dB)	Ant.Gain (dBi)	Emission level (dBm)	Limit (dBm)	Margin (dB)	Antenna Polarization (V/H)
165.8000	-59.44	1.53	2.05	-58.92	-13.00	-45.92	V
232.7300	-69.96	1.8	5.39	-66.37	-13.00	-53.37	V
299.6600	-76.82	2.09	5.59	-73.32	-13.00	-60.32	V
431.5800	-75.66	2.5	5.81	-72.35	-13.00	-59.35	V
564.4700	-71.08	2.86	6.03	-67.91	-13.00	-54.91	V
633.3400	-75.32	2.99	6.18	-72.13	-13.00	-59.13	V
132.8200	-63.17	1.36	-1.07	-65.60	-13.00	-52.60	H
232.7300	-63.92	1.8	5.39	-60.33	-13.00	-47.33	H
299.6600	-64.86	2.09	5.59	-61.36	-13.00	-48.36	H
412.1800	-65.22	2.45	5.89	-61.78	-13.00	-48.78	H
566.4100	-71.14	2.86	6.06	-67.94	-13.00	-54.94	H
624.6100	-67.46	2.96	6.15	-64.27	-13.00	-51.27	H

Remark:

1. *Measuring frequencies from 1 GHz to the 10th harmonic of highest fundamental frequency.*
2. *Measurements above show only up to 6 maximum emissions noted, or would be lesser, with " N/A " remark, if no specific emissions from the EUT are recorded (ie: margin>20dB from the applicable limit) and considered that's already beyond the background noise floor.*



Operation Mode: EDGE 1900 / TX / CH 512

Test Date: January 20, 2014

Temperature: 26°C

Tested by: Wayne Tsai

Humidity: 60 % RH

Polarity: Ver. / Hor.

Frequency (MHz)	S.G. (dBm)	Cable loss (dB)	Ant.Gain (dBi)	Emission level (dBm)	Limit (dBm)	Margin (dB)	Antenna Polarization (V/H)
40.6700	-59.46	0.73	-11.85	-72.04	-13.00	-59.04	V
135.7300	-72.65	1.37	-0.72	-74.74	-13.00	-61.74	V
245.3400	-86.13	1.82	5.5	-82.45	-13.00	-69.45	V
413.1500	-86.24	2.45	5.88	-82.81	-13.00	-69.81	V
479.1100	-84.27	2.64	5.56	-81.35	-13.00	-68.35	V
735.1900	-82.23	3.19	6.25	-79.17	-13.00	-66.17	V
55.2200	-64.04	0.84	-3.37	-68.25	-13.00	-55.25	H
131.8500	-70.35	1.35	-1.18	-72.88	-13.00	-59.88	H
249.2200	-79.96	1.84	5.65	-76.15	-13.00	-63.15	H
470.3800	-80.8	2.62	5.77	-77.65	-13.00	-64.65	H
714.8200	-78.52	3.15	6.4	-75.27	-13.00	-62.27	H
860.3200	-73.9	3.43	6.41	-70.92	-13.00	-57.92	H

Remark:

1. *Measuring frequencies from 1 GHz to the 10th harmonic of highest fundamental frequency.*
2. *Measurements above show only up to 6 maximum emissions noted, or would be lesser, with " N/A " remark, if no specific emissions from the EUT are recorded (ie: margin>20dB from the applicable limit) and considered that's already beyond the background noise floor.*



Operation Mode: EDGE 1900 / TX / CH 661

Test Date: January 20, 2014

Temperature: 26°C

Tested by: Wayne Tsai

Humidity: 60 % RH

Polarity: Ver. / Hor.

Frequency (MHz)	S.G. (dBm)	Cable loss (dB)	Ant.Gain (dBi)	Emission level (dBm)	Limit (dBm)	Margin (dB)	Antenna Polarization (V/H)
39.7000	-58.58	0.72	-12.6	-71.90	-13.00	-58.90	V
132.8200	-71.42	1.36	-1.07	-73.85	-13.00	-60.85	V
307.4200	-86.12	2.12	5.75	-82.49	-13.00	-69.49	V
414.1200	-85.27	2.45	5.87	-81.85	-13.00	-68.85	V
487.8400	-84.43	2.66	5.72	-81.37	-13.00	-68.37	V
644.9800	-81.95	3.02	6.19	-78.78	-13.00	-65.78	V
55.2200	-64.43	0.84	-3.37	-68.64	-13.00	-55.64	H
131.8500	-69.92	1.35	-1.18	-72.45	-13.00	-59.45	H
249.2200	-80.8	1.84	5.65	-76.99	-13.00	-63.99	H
378.2300	-82.23	2.31	5.96	-78.58	-13.00	-65.58	H
550.8900	-79.32	2.81	6.17	-75.96	-13.00	-62.96	H
808.9100	-77.02	3.34	6.27	-74.09	-13.00	-61.09	H

Remark:

1. *Measuring frequencies from 1 GHz to the 10th harmonic of highest fundamental frequency.*
2. *Measurements above show only up to 6 maximum emissions noted, or would be lesser, with " N/A " remark, if no specific emissions from the EUT are recorded (ie: margin>20dB from the applicable limit) and considered that's already beyond the background noise floor.*



Operation Mode: EDGE 1900 / TX / CH 810

Test Date: January 20, 2014

Temperature: 26°C

Tested by: Wayne Tsai

Humidity: 60 % RH

Polarity: Ver. / Hor.

Frequency (MHz)	S.G. (dBm)	Cable loss (dB)	Ant.Gain (dBi)	Emission level (dBm)	Limit (dBm)	Margin (dB)	Antenna Polarization (V/H)
39.7000	-58.35	0.72	-12.6	-71.67	-13.00	-58.67	V
135.7300	-71.03	1.37	-0.72	-73.12	-13.00	-60.12	V
245.3400	-86.26	1.82	5.5	-82.58	-13.00	-69.58	V
365.6200	-86.83	2.29	5.76	-83.36	-13.00	-70.36	V
593.5700	-84.04	2.89	6.27	-80.66	-13.00	-67.66	V
679.9000	-82.08	3.09	6.5	-78.67	-13.00	-65.67	V
55.2200	-64.27	0.84	-3.37	-68.48	-13.00	-55.48	H
129.9100	-69.77	1.34	-1.41	-72.52	-13.00	-59.52	H
307.4200	-79.62	2.12	5.75	-75.99	-13.00	-62.99	H
382.1100	-82.4	2.31	5.99	-78.72	-13.00	-65.72	H
610.0600	-79.33	2.94	6.29	-75.98	-13.00	-62.98	H
762.3500	-77.69	3.23	6.32	-74.60	-13.00	-61.60	H

Remark:

1. Measuring frequencies from 1 GHz to the 10th harmonic of highest fundamental frequency.
2. Measurements above show only up to 6 maximum emissions noted, or would be lesser, with " N/A " remark, if no specific emissions from the EUT are recorded (ie: margin>20dB from the applicable limit) and considered that's already beyond the background noise floor.



Above 1GHz

Operation Mode: GSM 850 / TX / CH 128

Test Date: January 20, 2014

Temperature: 26°C

Tested by: Wayne Tsai

Humidity: 60 % RH

Polarity: Ver. / Hor.

Frequency (MHz)	S.G. (dBm)	Cable loss (dB)	Ant.Gain (dBi)	Emission level (dBm)	Limit (dBm)	Margin (dB)	Antenna Polarization (V/H)
1651.000	-60.62	5.05	6.03	-59.64	-13.00	-46.64	V
2470.000	-53.54	6.3	6.06	-53.78	-13.00	-40.78	V
N/A							
1651.000	-58.48	5.05	6.03	-57.50	-13.00	-44.50	H
2470.000	-45.48	6.3	6.06	-45.72	-13.00	-32.72	H
N/A							

Remark:

1. *Measuring frequencies from 1 GHz to the 10th harmonic of highest fundamental frequency.*
2. *Measurements above show only up to 6 maximum emissions noted, or would be lesser, with " N/A " remark, if no specific emissions from the EUT are recorded (ie: margin>20dB from the applicable limit) and considered that's already beyond the background noise floor.*



Operation Mode: GSM 850 / TX / CH 190

Test Date: January 20, 2014

Temperature: 26°C

Tested by: Wayne Tsai

Humidity: 60 % RH

Polarity: Ver. / Hor.

Frequency (MHz)	S.G. (dBm)	Cable loss (dB)	Ant.Gain (dBi)	Emission level (dBm)	Limit (dBm)	Margin (dB)	Antenna Polarization (V/H)
2512.000	-55.09	6.37	6.13	-55.33	-13.00	-42.33	V
3779.000	-55.98	8.25	9.18	-55.05	-13.00	-42.05	V
N/A							
1672.000	-60.86	5.07	5.99	-59.94	-13.00	-46.94	H
2512.000	-48	6.37	6.13	-48.24	-13.00	-35.24	H
N/A							

Remark:

1. Measuring frequencies from 1 GHz to the 10th harmonic of highest fundamental frequency.
2. Measurements above show only up to 6 maximum emissions noted, or would be lesser; with " N/A " remark, if no specific emissions from the EUT are recorded (ie: margin > 20dB from the applicable limit) and considered that's already beyond the background noise floor.



Operation Mode: GSM 850 / TX / CH 251

Test Date: January 20, 2014

Temperature: 26°C

Tested by: Wayne Tsai

Humidity: 60 % RH

Polarity: Ver. / Hor.

Frequency (MHz)	S.G. (dBm)	Cable loss (dB)	Ant.Gain (dBi)	Emission level (dBm)	Limit (dBm)	Margin (dB)	Antenna Polarization (V/H)
2463.000	-55.86	6.29	6.05	-56.10	-13.00	-43.10	V
3877.000	-57.06	8.36	9.28	-56.14	-13.00	-43.14	V
N/A							
2547.000	-50.14	6.42	6.22	-50.34	-13.00	-37.34	H
3961.000	-56.33	8.37	9.36	-55.34	-13.00	-42.34	H
N/A							

Remark:

1. *Measuring frequencies from 1 GHz to the 10th harmonic of highest fundamental frequency.*
2. *Measurements above show only up to 6 maximum emissions noted, or would be lesser, with " N/A " remark, if no specific emissions from the EUT are recorded (ie: margin > 20dB from the applicable limit) and considered that's already beyond the background noise floor.*



Operation Mode: GPRS 850 / TX / CH 128

Test Date: January 20, 2014

Temperature: 26°C

Tested by: Wayne Tsai

Humidity: 60 % RH

Polarity: Ver. / Hor.

Frequency (MHz)	S.G. (dBm)	Cable loss (dB)	Ant.Gain (dBi)	Emission level (dBm)	Limit (dBm)	Margin (dB)	Antenna Polarization (V/H)
2127.000	-58.55	5.83	5.58	-58.80	-13.00	-45.80	V
2470.000	-51.97	6.3	6.06	-52.21	-13.00	-39.21	V
N/A							
1651.000	-55.34	5.05	6.03	-54.36	-13.00	-41.36	H
2470.000	-45.08	6.3	6.06	-45.32	-13.00	-32.32	H
N/A							

Remark:

1. Measuring frequencies from 1 GHz to the 10th harmonic of highest fundamental frequency.
2. Measurements above show only up to 6 maximum emissions noted, or would be lesser, with " N/A " remark, if no specific emissions from the EUT are recorded (ie: margin>20dB from the applicable limit) and considered that's already beyond the background noise floor.



Operation Mode: GPRS 850 / TX / CH 190

Test Date: January 20, 2014

Temperature: 26°C

Tested by: Wayne Tsai

Humidity: 60 % RH

Polarity: Ver. / Hor.

Frequency (MHz)	S.G. (dBm)	Cable loss (dB)	Ant.Gain (dBi)	Emission level (dBm)	Limit (dBm)	Margin (dB)	Antenna Polarization (V/H)
2512.000	-54.17	6.37	6.13	-54.41	-13.00	-41.41	V
3793.000	-54.52	8.26	9.19	-53.59	-13.00	-40.59	V
N/A							
2512.000	-47.62	6.37	6.13	-47.86	-13.00	-34.86	H
4052.000	-53.91	8.41	9.44	-52.88	-13.00	-39.88	H
N/A							

Remark:

1. Measuring frequencies from 1 GHz to the 10th harmonic of highest fundamental frequency.
2. Measurements above show only up to 6 maximum emissions noted, or would be lesser, with " N/A " remark, if no specific emissions from the EUT are recorded (ie: margin>20dB from the applicable limit) and considered that's already beyond the background noise floor.



Operation Mode: GPRS 850 / TX / CH 251

Test Date: January 20, 2014

Temperature: 26°C

Tested by: Wayne Tsai

Humidity: 60 % RH

Polarity: Ver. / Hor.

Frequency (MHz)	S.G. (dBm)	Cable loss (dB)	Ant.Gain (dBi)	Emission level (dBm)	Limit (dBm)	Margin (dB)	Antenna Polarization (V/H)
2463.000	-55.19	6.29	6.05	-55.43	-13.00	-42.43	V
3968.000	-53.77	8.36	9.37	-52.76	-13.00	-39.76	V
N/A							
2547.000	-49.59	6.42	6.22	-49.79	-13.00	-36.79	H
4150.000	-53.34	8.48	9.52	-52.30	-13.00	-39.30	H
N/A							

Remark:

1. Measuring frequencies from 1 GHz to the 10th harmonic of highest fundamental frequency.
2. Measurements above show only up to 6 maximum emissions noted, or would be lesser, with " N/A " remark, if no specific emissions from the EUT are recorded (ie: margin>20dB from the applicable limit) and considered that's already beyond the background noise floor.



Operation Mode: GSM 1900 / TX / CH 512

Test Date: January 20, 2014

Temperature: 26°C

Tested by: Wayne Tsai

Humidity: 60 % RH

Polarity: Ver. / Hor.

Frequency (MHz)	S.G. (dBm)	Cable loss (dB)	Ant.Gain (dBi)	Emission level (dBm)	Limit (dBm)	Margin (dB)	Antenna Polarization (V/H)
3702.000	-47.97	8.2	9.1	-47.07	-13.00	-34.07	V
5550.000	-42.5	10.06	10.81	-41.75	-13.00	-28.75	V
7398.000	-42.01	12.09	12.54	-41.56	-13.00	-28.56	V
N/A							
5550.000	-47.67	10.06	10.81	-46.92	-13.00	-33.92	H
7398.000	-43.36	12.09	12.54	-42.91	-13.00	-29.91	H
N/A							

Remark:

1. Measuring frequencies from 1 GHz to the 10th harmonic of highest fundamental frequency.
2. Measurements above show only up to 6 maximum emissions noted, or would be lesser, with " N/A " remark, if no specific emissions from the EUT are recorded (ie: margin>20dB from the applicable limit) and considered that's already beyond the background noise floor.



Operation Mode: GSM 1900 / TX / CH 661

Test Date: January 20, 2014

Temperature: 26°C

Tested by: Wayne Tsai

Humidity: 60 % RH

Polarity: Ver. / Hor.

Frequency (MHz)	S.G. (dBm)	Cable loss (dB)	Ant.Gain (dBi)	Emission level (dBm)	Limit (dBm)	Margin (dB)	Antenna Polarization (V/H)
5641.000	-46.18	10.18	10.83	-45.53	-13.00	-32.53	V
7524.000	-43.47	12.23	12.72	-42.98	-13.00	-29.98	V
N/A							
3758.000	-49.36	8.23	9.16	-48.43	-13.00	-35.43	H
5641.000	-29.6	10.18	10.83	-28.95	-13.00	-15.95	H
N/A							

Remark:

1. Measuring frequencies from 1 GHz to the 10th harmonic of highest fundamental frequency.
2. Measurements above show only up to 6 maximum emissions noted, or would be lesser, with " N/A " remark, if no specific emissions from the EUT are recorded (ie: margin>20dB from the applicable limit) and considered that's already beyond the background noise floor.



Operation Mode: GSM 1900 / TX / CH 810

Test Date: January 20, 2014

Temperature: 26°C

Tested by: Wayne Tsai

Humidity: 60 % RH

Polarity: Ver. / Hor.

Frequency (MHz)	S.G. (dBm)	Cable loss (dB)	Ant.Gain (dBi)	Emission level (dBm)	Limit (dBm)	Margin (dB)	Antenna Polarization (V/H)
3821.000	-44.53	8.29	9.22	-43.60	-13.00	-30.60	V
5732.000	-41.5	10.24	10.85	-40.89	-13.00	-27.89	V
7643.000	-40.49	12.26	12.84	-39.91	-13.00	-26.91	V
N/A							
3821.000	-48.12	8.29	9.22	-47.19	-13.00	-34.19	H
5732.000	-44.65	10.24	10.85	-44.04	-13.00	-31.04	H
7636.000	-39.97	12.24	12.84	-39.37	-13.00	-26.37	H
N/A							

Remark:

1. Measuring frequencies from 1 GHz to the 10th harmonic of highest fundamental frequency.
2. Measurements above show only up to 6 maximum emissions noted, or would be lesser, with " N/A " remark, if no specific emissions from the EUT are recorded (ie: margin>20dB from the applicable limit) and considered that's already beyond the background noise floor.



Operation Mode: GPRS 1900 / TX / CH 512

Test Date: January 20, 2014

Temperature: 26°C

Tested by: Wayne Tsai

Humidity: 60 % RH

Polarity: Ver. / Hor.

Frequency (MHz)	S.G. (dBm)	Cable loss (dB)	Ant.Gain (dBi)	Emission level (dBm)	Limit (dBm)	Margin (dB)	Antenna Polarization (V/H)
3702.000	-46.04	8.2	9.1	-45.14	-13.00	-32.14	V
5550.000	-42.05	10.06	10.81	-41.30	-13.00	-28.30	V
7398.000	-42.15	12.09	12.54	-41.70	-13.00	-28.70	V
N/A							
3702.000	-49.19	8.2	9.1	-48.29	-13.00	-35.29	H
5550.000	-46.86	10.06	10.81	-46.11	-13.00	-33.11	H
7286.000	-46.19	12.01	12.36	-45.84	-13.00	-32.84	H
N/A							

Remark:

1. Measuring frequencies from 1 GHz to the 10th harmonic of highest fundamental frequency.
2. Measurements above show only up to 6 maximum emissions noted, or would be lesser, with " N/A " remark, if no specific emissions from the EUT are recorded (ie: margin>20dB from the applicable limit) and considered that's already beyond the background noise floor.



Operation Mode: GPRS 1900 / TX / CH 661

Test Date: January 20, 2014

Temperature: 26°C

Tested by: Wayne Tsai

Humidity: 60 % RH

Polarity: Ver. / Hor.

Frequency (MHz)	S.G. (dBm)	Cable loss (dB)	Ant.Gain (dBi)	Emission level (dBm)	Limit (dBm)	Margin (dB)	Antenna Polarization (V/H)
3758.000	-49.95	8.23	9.16	-49.02	-13.00	-36.02	V
5641.000	-41.54	10.18	10.83	-40.89	-13.00	-27.89	V
7517.000	-37.86	12.24	12.72	-37.38	-13.00	-24.38	V
N/A							
5641.000	-43.84	10.18	10.83	-43.19	-13.00	-30.19	H
7517.000	-42.24	12.24	12.72	-41.76	-13.00	-28.76	H
N/A							

Remark:

1. Measuring frequencies from 1 GHz to the 10th harmonic of highest fundamental frequency.
2. Measurements above show only up to 6 maximum emissions noted, or would be lesser, with " N/A " remark, if no specific emissions from the EUT are recorded (ie: margin>20dB from the applicable limit) and considered that's already beyond the background noise floor.



Operation Mode: GPRS 1900 / TX / CH 810

Test Date: January 20, 2014

Temperature: 26°C

Tested by: Wayne Tsai

Humidity: 60 % RH

Polarity: Ver. / Hor.

Frequency (MHz)	S.G. (dBm)	Cable loss (dB)	Ant.Gain (dBi)	Emission level (dBm)	Limit (dBm)	Margin (dB)	Antenna Polarization (V/H)
3821.000	-47.24	8.29	9.22	-46.31	-13.00	-33.31	V
5732.000	-43.99	10.24	10.85	-43.38	-13.00	-30.38	V
7636.000	-37.3	12.24	12.84	-36.70	-13.00	-23.70	V
N/A							
5732.000	-45.84	10.24	10.85	-45.23	-13.00	-32.23	H
7636.000	-41.3	12.24	12.84	-40.70	-13.00	-27.70	H
N/A							

Remark:

1. Measuring frequencies from 1 GHz to the 10th harmonic of highest fundamental frequency.
2. Measurements above show only up to 6 maximum emissions noted, or would be lesser, with " N/A " remark, if no specific emissions from the EUT are recorded (ie: margin>20dB from the applicable limit) and considered that's already beyond the background noise floor.



Operation Mode: EDGE 850 / TX / CH 128

Test Date: January 20, 2014

Temperature: 26°C

Tested by: Wayne Tsai

Humidity: 60 % RH

Polarity: Ver. / Hor.

Frequency (MHz)	S.G. (dBm)	Cable loss (dB)	Ant.Gain (dBi)	Emission level (dBm)	Limit (dBm)	Margin (dB)	Antenna Polarization (V/H)
2463.000	-50.18	6.29	6.05	-50.42	-13.00	-37.42	V
3807.000	-54.62	8.27	9.21	-53.68	-13.00	-40.68	V
N/A							
1651.000	-56.43	5.05	6.03	-55.45	-13.00	-42.45	H
2470.000	-44.06	6.3	6.06	-44.30	-13.00	-31.30	H
N/A							

Remark:

1. Measuring frequencies from 1 GHz to the 10th harmonic of highest fundamental frequency.
2. Measurements above show only up to 6 maximum emissions noted, or would be lesser, with " N/A " remark, if no specific emissions from the EUT are recorded (ie: margin>20dB from the applicable limit) and considered that's already beyond the background noise floor.



Operation Mode: EDGE 850 / TX / CH 190

Test Date: January 20, 2014

Temperature: 26°C

Tested by: Wayne Tsai

Humidity: 60 % RH

Polarity: Ver. / Hor.

Frequency (MHz)	S.G. (dBm)	Cable loss (dB)	Ant.Gain (dBi)	Emission level (dBm)	Limit (dBm)	Margin (dB)	Antenna Polarization (V/H)
2512.000	-54.2	6.37	6.13	-54.44	-13.00	-41.44	V
5669.000	-53.73	10.17	10.83	-53.07	-13.00	-40.07	V
N/A							
1966.000	-54.92	5.63	5.46	-55.09	-13.00	-42.09	H
2512.000	-46.93	6.37	6.13	-47.17	-13.00	-34.17	H
N/A							

Remark:

1. Measuring frequencies from 1 GHz to the 10th harmonic of highest fundamental frequency.
2. Measurements above show only up to 6 maximum emissions noted, or would be lesser, with " N/A " remark, if no specific emissions from the EUT are recorded (ie: margin > 20dB from the applicable limit) and considered that's already beyond the background noise floor.



Operation Mode: EDGE 850 / TX / CH 251

Test Date: January 20, 2014

Temperature: 26°C

Tested by: Wayne Tsai

Humidity: 60 % RH

Polarity: Ver. / Hor.

Frequency (MHz)	S.G. (dBm)	Cable loss (dB)	Ant.Gain (dBi)	Emission level (dBm)	Limit (dBm)	Margin (dB)	Antenna Polarization (V/H)
2463.000	-53.16	6.29	6.05	-53.40	-13.00	-40.40	V
3114.000	-56.97	7.18	7.74	-56.41	-13.00	-43.41	V
N/A							
1672.000	-58.51	5.07	5.99	-57.59	-13.00	-44.59	H
2512.000	-46.97	6.37	6.13	-47.21	-13.00	-34.21	H
N/A							

Remark:

1. Measuring frequencies from 1 GHz to the 10th harmonic of highest fundamental frequency.
2. Measurements above show only up to 6 maximum emissions noted, or would be lesser, with " N/A " remark, if no specific emissions from the EUT are recorded (ie: margin>20dB from the applicable limit) and considered that's already beyond the background noise floor.



Operation Mode: EDGE 1900 / TX / CH 512

Test Date: January 20, 2014

Temperature: 26°C

Tested by: Wayne Tsai

Humidity: 60 % RH

Polarity: Ver. / Hor.

Frequency (MHz)	S.G. (dBm)	Cable loss (dB)	Ant.Gain (dBi)	Emission level (dBm)	Limit (dBm)	Margin (dB)	Antenna Polarization (V/H)
3702.000	-45.76	8.2	9.1	-44.86	-13.00	-31.86	V
5550.000	-42.43	10.06	10.81	-41.68	-13.00	-28.68	V
N/A							
3702.000	-49.01	8.2	9.1	-48.11	-13.00	-35.11	H
5550.000	-46.18	10.06	10.81	-45.43	-13.00	-32.43	H
N/A							

Remark:

1. Measuring frequencies from 1 GHz to the 10th harmonic of highest fundamental frequency.
2. Measurements above show only up to 6 maximum emissions noted, or would be lesser, with " N/A " remark, if no specific emissions from the EUT are recorded (ie: margin > 20dB from the applicable limit) and considered that's already beyond the background noise floor.



Operation Mode: EDGE 1900 / TX / CH 661

Test Date: January 20, 2014

Temperature: 26°C

Tested by: Wayne Tsai

Humidity: 60 % RH

Polarity: Ver. / Hor.

Frequency (MHz)	S.G. (dBm)	Cable loss (dB)	Ant.Gain (dBi)	Emission level (dBm)	Limit (dBm)	Margin (dB)	Antenna Polarization (V/H)
3758.000	-50.25	8.23	9.16	-49.32	-13.00	-36.32	V
5641.000	-41.41	10.18	10.83	-40.76	-13.00	-27.76	V
7517.000	-42.39	12.24	12.72	-41.91	-13.00	-28.91	V
N/A							
5641.000	-44.94	10.18	10.83	-44.29	-13.00	-31.29	H
7517.000	-41.85	12.24	12.72	-41.37	-13.00	-28.37	H
N/A							

Remark:

1. Measuring frequencies from 1 GHz to the 10th harmonic of highest fundamental frequency.
2. Measurements above show only up to 6 maximum emissions noted, or would be lesser, with " N/A " remark, if no specific emissions from the EUT are recorded (ie: margin > 20dB from the applicable limit) and considered that's already beyond the background noise floor.



Operation Mode: EDGE 1900 / TX / CH 810

Test Date: January 20, 2014

Temperature: 26°C

Tested by: Wayne Tsai

Humidity: 60 % RH

Polarity: Ver. / Hor.

Frequency (MHz)	S.G. (dBm)	Cable loss (dB)	Ant.Gain (dBi)	Emission level (dBm)	Limit (dBm)	Margin (dB)	Antenna Polarization (V/H)
3821.000	-48.67	8.29	9.22	-47.74	-13.00	-34.74	V
5732.000	-43.52	10.24	10.85	-42.91	-13.00	-29.91	V
7636.000	-38.79	12.24	12.84	-38.19	-13.00	-25.19	V
N/A							
3821.000	-50.73	8.29	9.22	-49.80	-13.00	-36.80	H
5732.000	-45.4	10.24	10.85	-44.79	-13.00	-31.79	H
7643.000	-41.04	12.26	12.84	-40.46	-13.00	-27.46	H
N/A							

Remark:

1. *Measuring frequencies from 1 GHz to the 10th harmonic of highest fundamental frequency.*
2. *Measurements above show only up to 6 maximum emissions noted, or would be lesser, with " N/A " remark, if no specific emissions from the EUT are recorded (ie: margin>20dB from the applicable limit) and considered that's already beyond the background noise floor.*



7.6 FREQUENCY STABILITY V.S. TEMPERATURE MEASUREMENT

LIMIT

According to FCC §2.1055, FCC §24.235, RSS-132 (4.3) & RSS-133 (6.3).

Frequency Tolerance: 2.5 ppm

Test Configuration

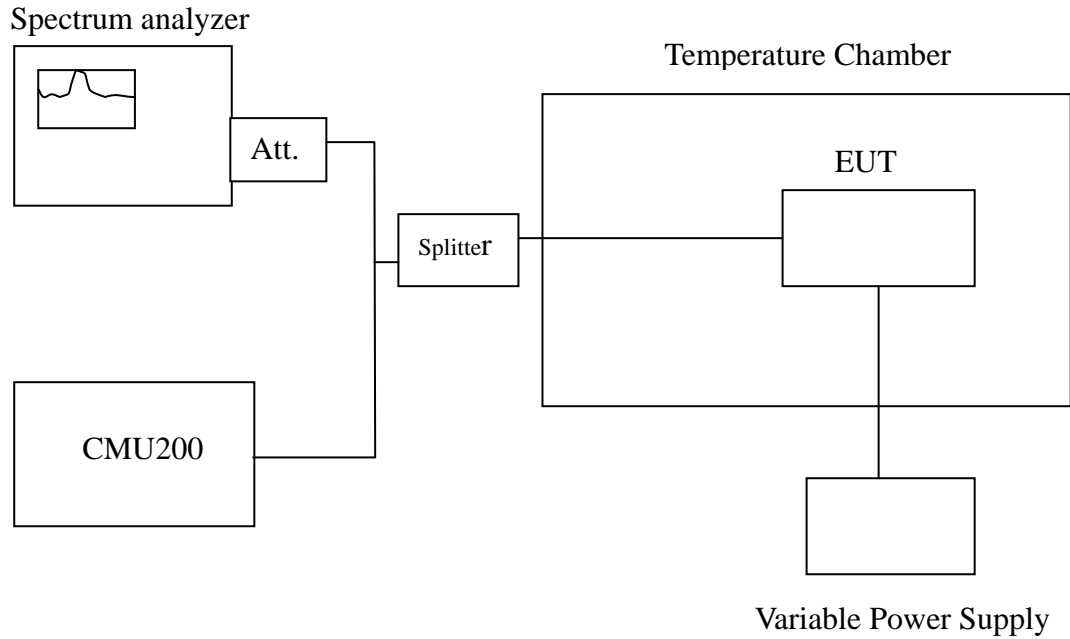

Remark: Measurement setup for testing on Antenna connector.



TEST PROCEDURE

The equipment under test was connected to an external AC or DC power supply and input rated voltage. RF output was connected to a frequency counter or spectrum analyzer via feed through attenuators. The EUT was placed inside the temperature chamber. Set the spectrum analyzer RBW low enough to obtain the desired frequency resolution and measure EUT 20°C operating frequency as reference frequency. Turn EUT off and set the chamber temperature to -30°C. After the temperature stabilized for approximately 30 minutes recorded the frequency. Repeat step measure with 10°C increased per stage until the highest temperature of +50°C reached.

TEST RESULTS

No non-compliance noted.

Reference Frequency: GSM Mid Channel 836.6 MHz @ 20°C				
Limit: ± 2.5 ppm = 2091 Hz				
Power Supply Vdc	Environment Temperature (°C)	Frequency (Hz)	Delta (Hz)	Limit (Hz)
120	50	836599990	-16	2091
	40	836599985	-21	
	30	836599983	-23	
	20	836600006	0	
	10	836599972	-34	
	0	836599991	-15	
	-10	836599992	-14	
	-20	836599994	-12	
	-30	836599999	-7	

Reference Frequency: GSM Mid Channel 1880 MHz @ 20°C				
Limit: ± 2.5 ppm = 4700 Hz				
Power Supply Vdc	Environment Temperature (°C)	Frequency (Hz)	Delta (Hz)	Limit (Hz)
120	50	1879999980	-59	4700
	40	1879999965	-74	
	30	1879999972	-67	
	20	1880000039	0	
	10	1879999969	-70	
	0	1879999971	-68	
	-10	1879999974	-65	
	-20	1879999973	-66	
	-30	1879999967	-72	



Reference Frequency: GPRS Mid Channel 836.6 MHz @ 20°C				
Limit: +/- 2.5 ppm = 2091 Hz				
Power Supply Vdc	Environment Temperature (°C)	Frequency (Hz)	Delta (Hz)	Limit (Hz)
120	50	836599983	-25	2091
	40	836599981	-27	
	30	836599982	-26	
	20	836600008	0	
	10	836599971	-37	
	0	836599967	-41	
	-10	836599963	-45	
	-20	836599965	-43	
	-30	836599960	-48	

Reference Frequency: GPRS Mid Channel 1880 MHz @ 20°C				
Limit: ± 2.5 ppm = 4700 Hz				
Power Supply Vdc	Environment Temperature (°C)	Frequency (Hz)	Delta (Hz)	Limit (Hz)
120	50	1879999972	-57	4700
	40	1879999971	-58	
	30	1879999967	-62	
	20	1880000029	0	
	10	1879999975	-54	
	0	1879999971	-58	
	-10	1879999984	-45	
	-20	1879999965	-64	
	-30	1879999961	-68	



Reference Frequency: EDGE Mid Channel 836.6 MHz @ 20°C				
Limit: +/- 2.5 ppm = 2091 Hz				
Power Supply Vdc	Environment Temperature (°C)	Frequency (Hz)	Delta (Hz)	Limit (Hz)
120	50	836599979	-41	2091
	40	836599995	-25	
	30	836599990	-30	
	20	836600020	0	
	10	836599986	-34	
	0	836599967	-53	
	-10	836599992	-28	
	-20	836599978	-42	
	-30	836599964	-56	

Reference Frequency: EDGE Mid Channel 1880 MHz @ 20°C				
Limit: ± 2.5 ppm = 4700Hz				
Power Supply Vdc	Environment Temperature (°C)	Frequency (Hz)	Delta (Hz)	Limit (Hz)
120	50	1879999975	-64	4700
	40	1879999981	-58	
	30	1879999985	-54	
	20	1880000039	0	
	10	1879999975	-64	
	0	1879999961	-78	
	-10	1879999974	-65	
	-20	1879999972	-67	
	-30	1879999956	-83	



7.7 FREQUENCY STABILITY V.S. VOLTAGE MEASUREMENT

LIMIT

According to FCC §2.1055, FCC §24.235,

Frequency Tolerance: 2.5 ppm.

According to RSS-132 (4.3) & RSS-133 (6.3).

The carrier frequency shall not depart from the reference frequency in excess of ± 2.5 ppm for mobile stations and ± 1.0 ppm for base stations.

Test Configuration

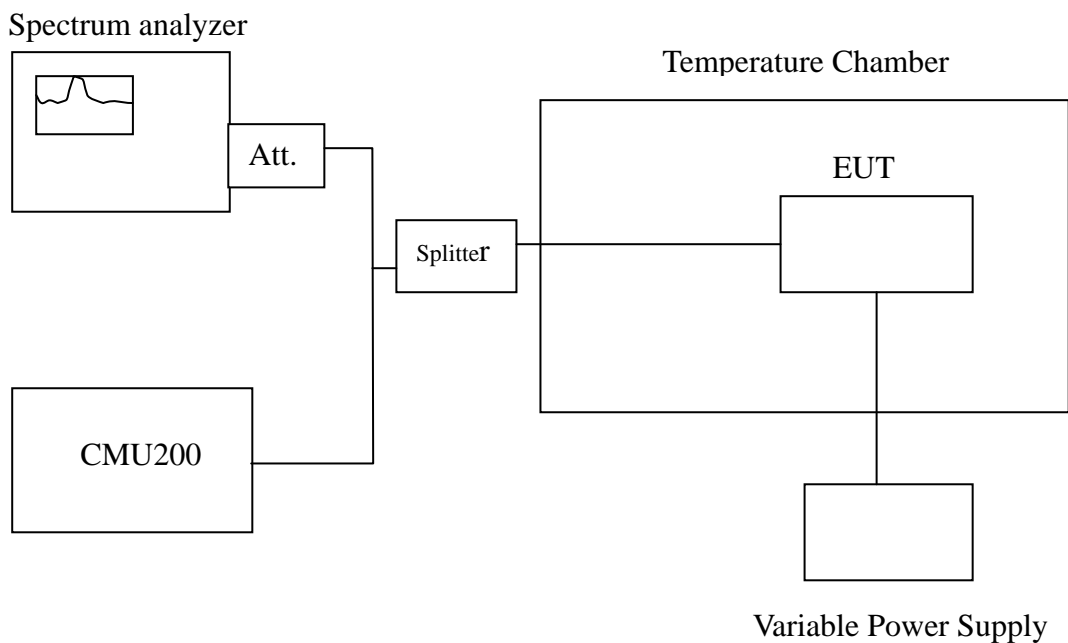

Remark: Measurement setup for testing on Antenna connector.



TEST PROCEDURE

Set chamber temperature to 20°C. Use a variable AC power supply / DC power source to power the EUT and set the voltage to rated voltage. Set the spectrum analyzer RBW low enough to obtain the desired frequency resolution and recorded the frequency.

Reduce the input voltage to specify extreme voltage variation (± 15%) and endpoint, record the maximum frequency change.

TEST RESULTS

No non-compliance noted.

Reference Frequency: GSM Mid Channel 836.6 MHz @ 20°C				
Limit: ± 2.5 ppm = 2091Hz				
Power Supply Vdc	Environment Temperature (°C)	Frequency (Hz)	Delta (Hz)	Limit (Hz)
138	20	836600005	-1	2091
120		836600006	0	
102		836600008	2	
END		836600009	3	

Reference Frequency: GSM Mid Channel 1880 MHz @ 20°C				
Limit: ± 2.5 ppm = 4700 Hz				
Power Supply Vdc	Environment Temperature (°C)	Frequency (Hz)	Delta (Hz)	Limit (Hz)
138	20	1880000026	-13	4700
120		1880000039	0	
102		1880000041	2	
END		1880000026	-13	



Reference Frequency: GPRS Mid Channel 836.6 MHz @ 20°C				
Limit: ± 2.5 ppm = 2091Hz				
Power Supply Vdc	Environment Temperature (°C)	Frequency (Hz)	Delta (Hz)	Limit (Hz)
138	20	836600005	-3	2091
120		836600008	0	
102		836600007	-1	
END		836600006	-2	

Reference Frequency: GPRS Mid Channel 1880 MHz @ 20°C				
Limit: ± 2.5 ppm = 4700 Hz				
Power Supply Vdc	Environment Temperature (°C)	Frequency (Hz)	Delta (Hz)	Limit (Hz)
138	20	1880000028	-1	4700
120		1880000029	0	
102		1880000023	-6	
END		1880000012	-17	



Reference Frequency: EDGE Mid Channel 836.6 MHz @ 20°C				
Limit: ± 2.5 ppm = 2091Hz				
Power Supply Vdc	Environment Temperature (°C)	Frequency (Hz)	Delta (Hz)	Limit (Hz)
138	20	836600025	5	2091
120		836600020	0	
102		836600005	-15	
END		836600009	-11	

Reference Frequency: EDGE Mid Channel 1880 MHz @ 20°C				
Limit: ± 2.5 ppm = 4700Hz				
Power Supply Vdc	Environment Temperature (°C)	Frequency (Hz)	Delta (Hz)	Limit (Hz)
138	20	1880000018	-21	4700
120		1880000039	0	
102		1880000018	-21	
END		1880000019	-20	