

Middle Channel:



Highest Channel:



NB IoT BAND 25.

Tone 3.75 kHz.  $\pi/2$  - BPSK MODULATION

Lowest Channel

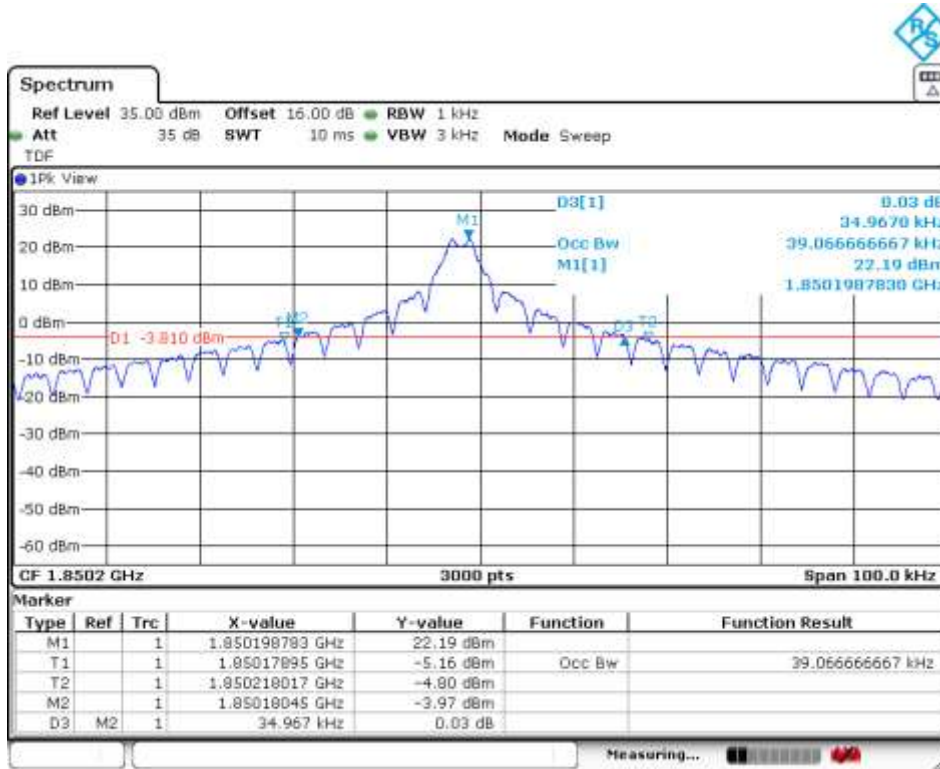

Middle Channel

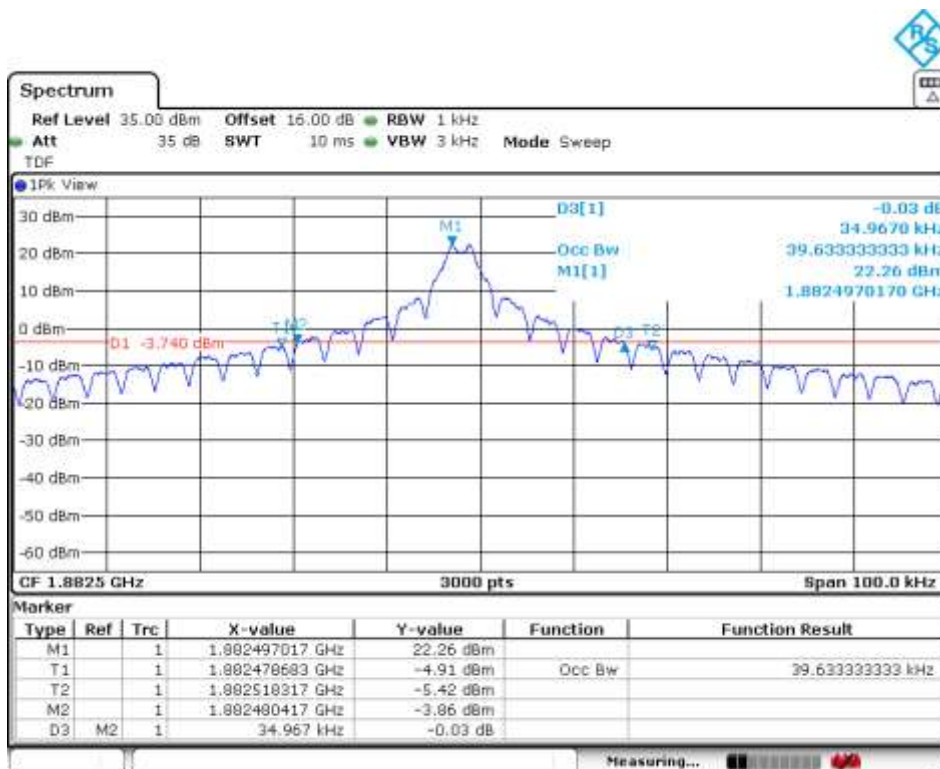

Highest Channel

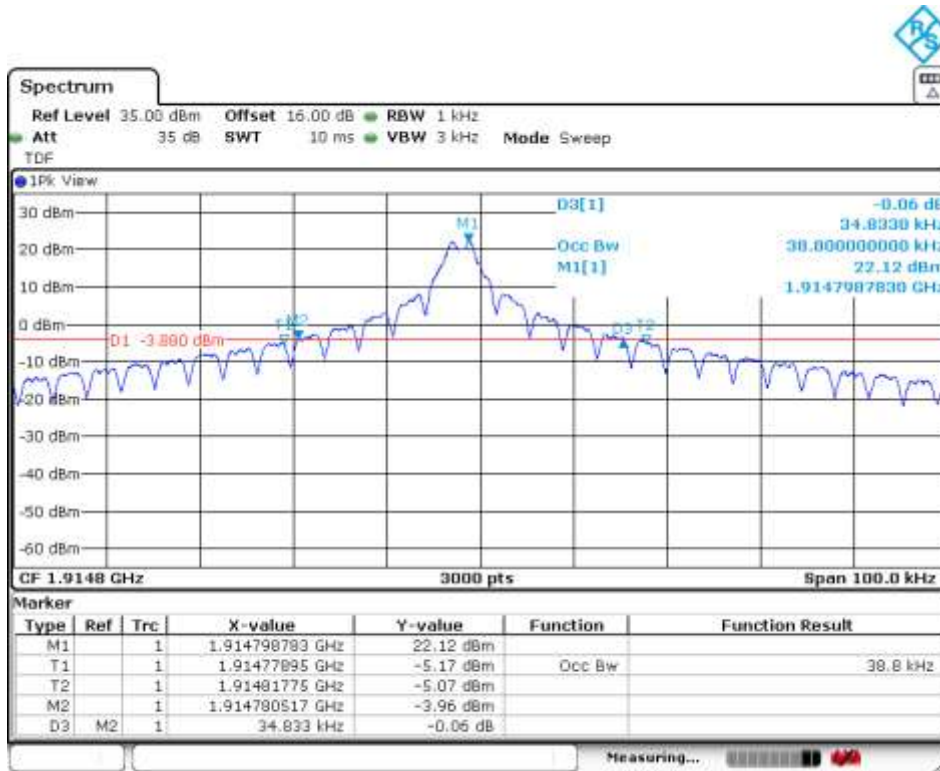

Tone 3.75 kHz.  $\pi/4$  - QPSK MODULATION

Lowest Channel

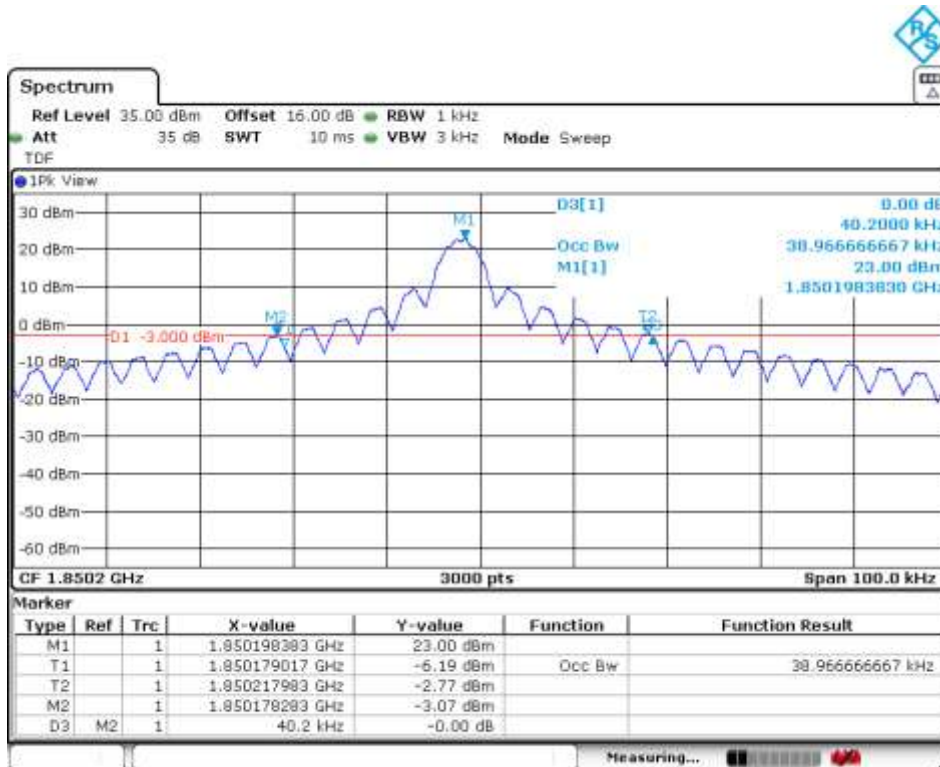

Middle Channel

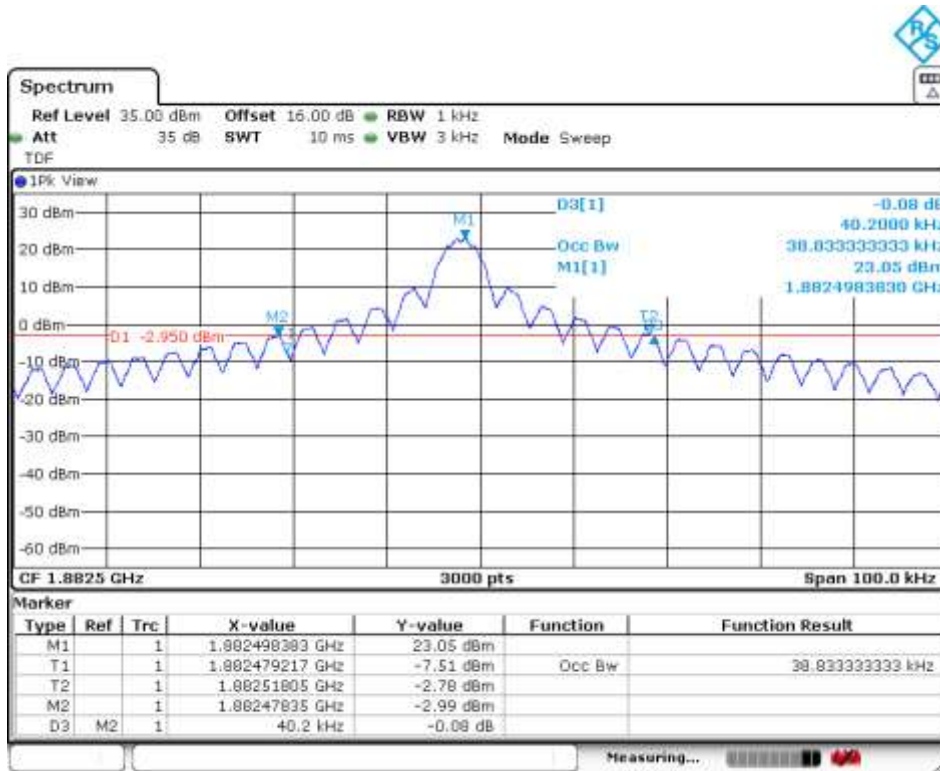

Highest Channel

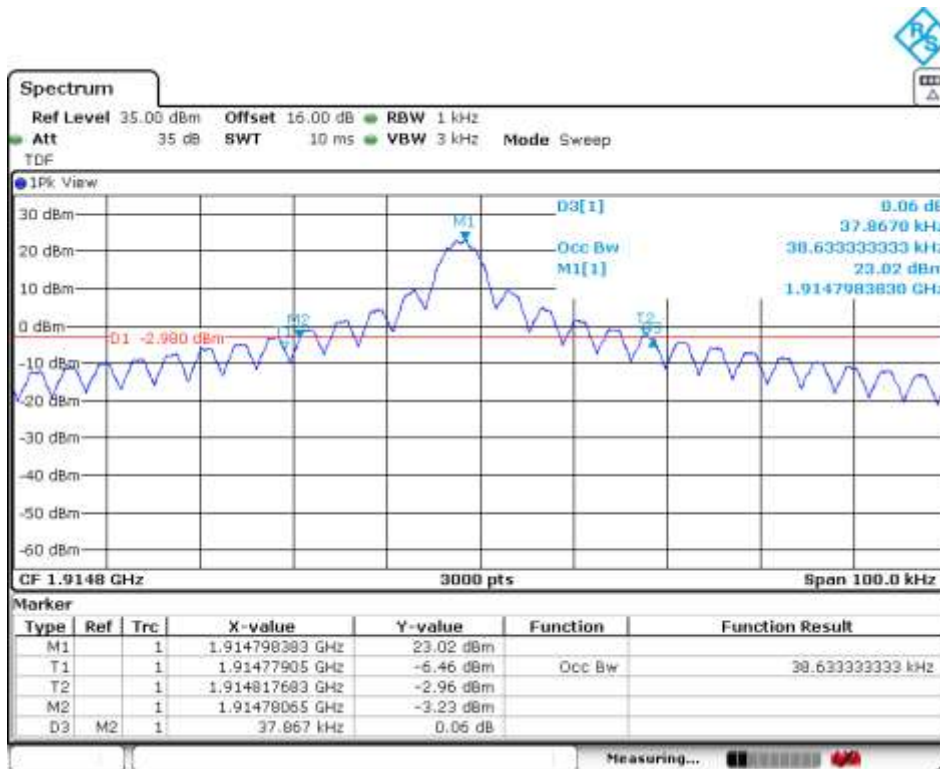

Tone 15 kHz.  $\pi/2$  - BPSK MODULATION

Lowest Channel



Middle Channel

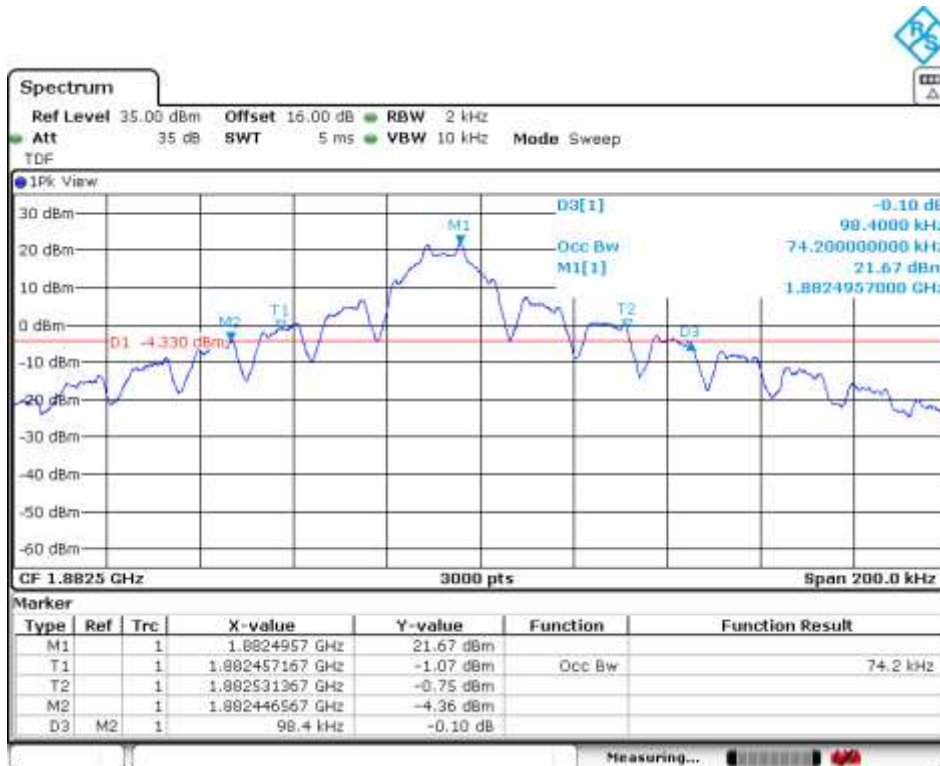

Highest Channel



12 Tones 15 kHz.  $\pi/4$  - QPSK MODULATION

Lowest Channel



Middle Channel



Highest Channel



## Spurious emissions at antenna terminals

### SPECIFICATION:

FCC §2.1051 and §24.238. RSS-133. Clause 6.5.

The power of emissions shall be attenuated below the transmitter power (P) by a factor of at least  $43 + 10 \log (P)$  dB. P in watts.

At  $P_o$  transmitting power, the specified minimum attenuation becomes  $43+10 \log (P_o)$ , and the level in dBm relative  $P_o$  becomes:

$$P_o \text{ (dBm)} - [43 + 10 \log (P_o \text{ in mwatts}) - 30] = -13 \text{ dBm.}$$

### METHOD:

The EUT RF output connector was connected to a spectrum analyser and to the Universal Radio Communication tester R&S CMW500 (selecting maximum transmission power of the EUT and different modes of modulation) using a 50 ohm attenuator and a power divider.

The spectrum was investigated from 9 kHz to 9 GHz for NB-IoT Band 5 and 26.

The reading of the spectrum analyser is corrected with the attenuation loss of connection between output terminal of EUT and input of the spectrum analyser.

The configuration of tones and modulation which is the worst case for conducted power was used.

#### Measurement Limit:

According to specification. the power of emissions shall be attenuated below the transmitter power (P) by a factor of at least  $43 + 10 \log (P)$  dB. P in watts.

At  $P_o$  transmitting power. the specified minimum attenuation becomes  $43+10 \log (P_o)$ . and the level in dBm relative  $P_o$  becomes:

$$P_o \text{ (dBm)} - [43 + 10 \log (P_o \text{ in mwatts}) - 30] = -13 \text{ dBm}$$

### TEST SETUP:

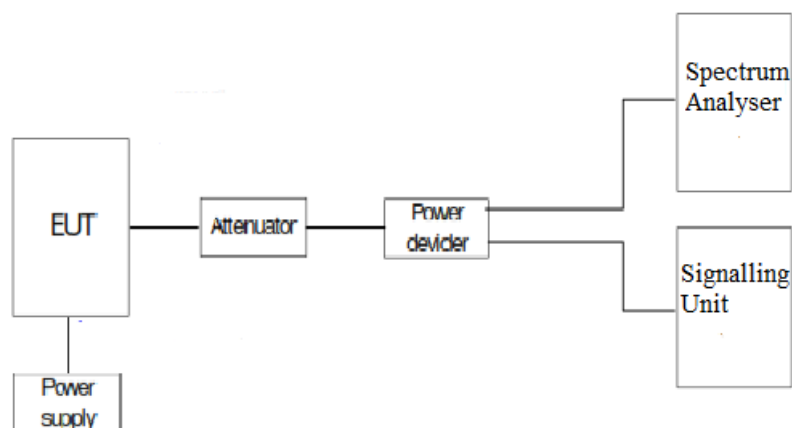



2G Band 1900 MHz. GPRS MODULATION.

1. CHANNEL: LOWEST

All peaks are more than 20 dB below the limit.

2. CHANNEL: MIDDLE

All peaks are more than 20 dB below the limit.

3. CHANNEL: HIGHEST

All peaks are more than 20 dB below the limit.

2G Band 1900 MHz. EDGE MODULATION.

1. CHANNEL: LOWEST

All peaks are more than 20 dB below the limit.

2. CHANNEL: MIDDLE

All peaks are more than 20 dB below the limit.

3. CHANNEL: HIGHEST

All peaks are more than 20 dB below the limit.

NBLoT BAND 25 (Tone 3.75 kHz.  $\pi/2$  - BPSK MODULATION)

1. CHANNEL: LOWEST

All peaks are more than 20 dB below the limit.

2. CHANNEL: MIDDLE

All peaks are more than 20 dB below the limit.

3. CHANNEL: HIGHEST

All peaks are more than 20 dB below the limit.

NBLoT BAND 25 (Tone 15 kHz.  $\pi/4$  - QPSK MODULATION)

1. CHANNEL: LOWEST

All peaks are more than 20 dB below the limit.

2. CHANNEL: MIDDLE

All peaks are more than 20 dB below the limit.

3. CHANNEL: HIGHEST

All peaks are more than 20 dB below the limit.

Measurement uncertainty (dB):  $< \pm 2.76$

Verdict: PASS

RESULTS (see plots in next pages)

2G Band 1900 MHz. GPRS MODULATION.

Lowest Channel:

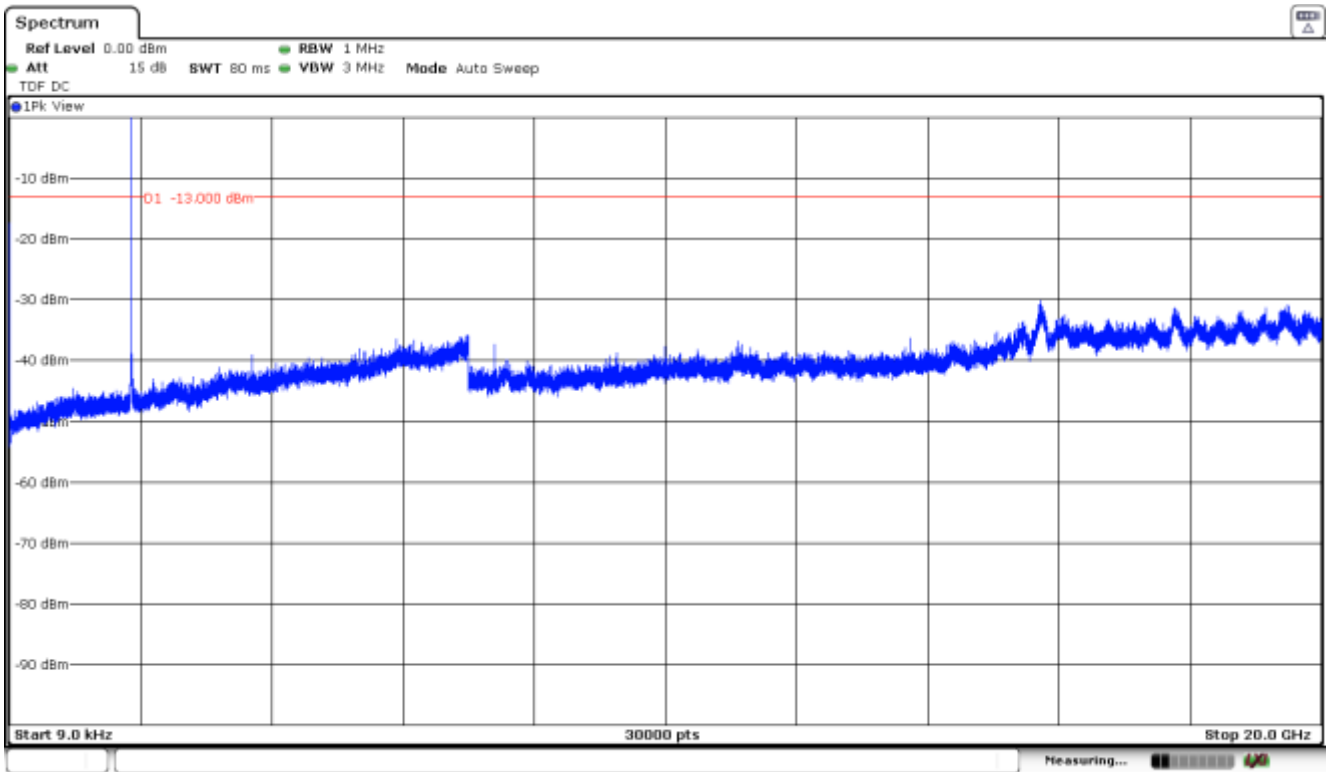

The peak above the limit is the carrier frequency.

Middle Channel:

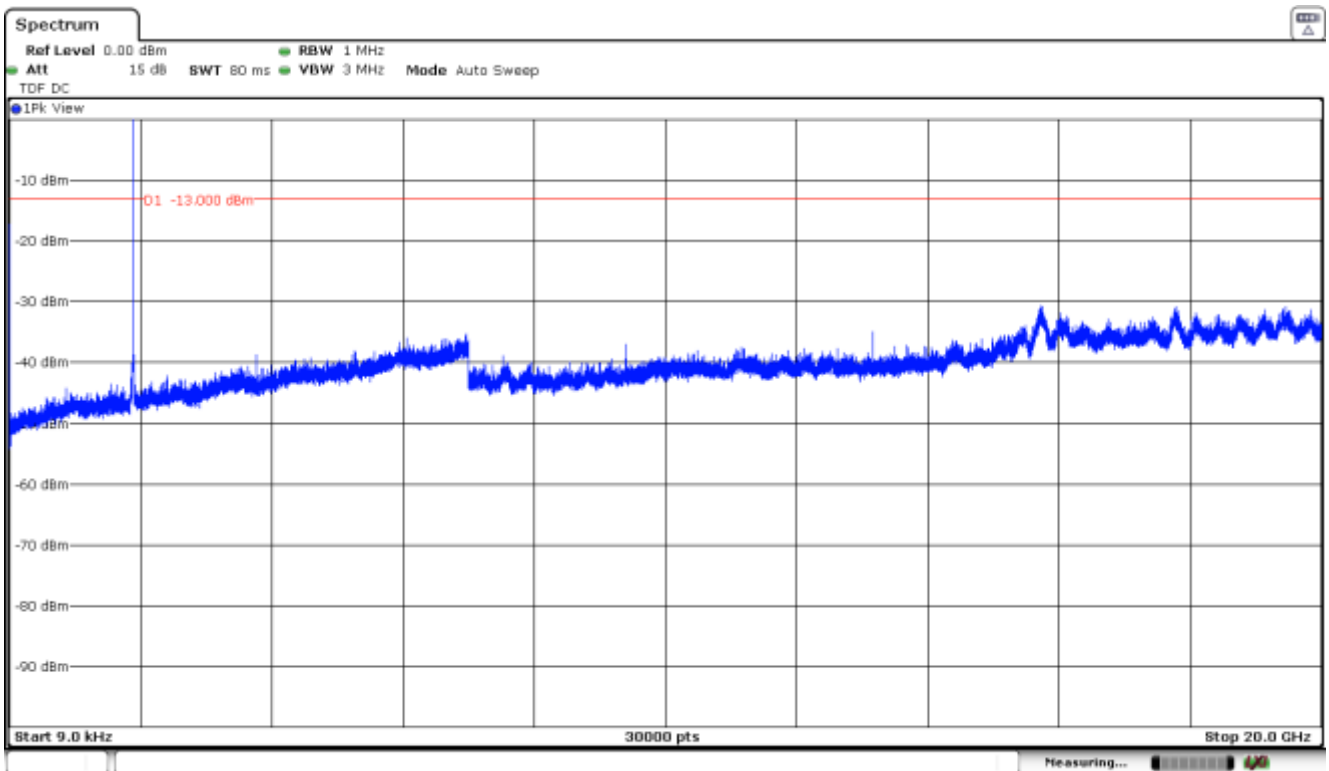

The peak above the limit is the carrier frequency.

Highest Channel:

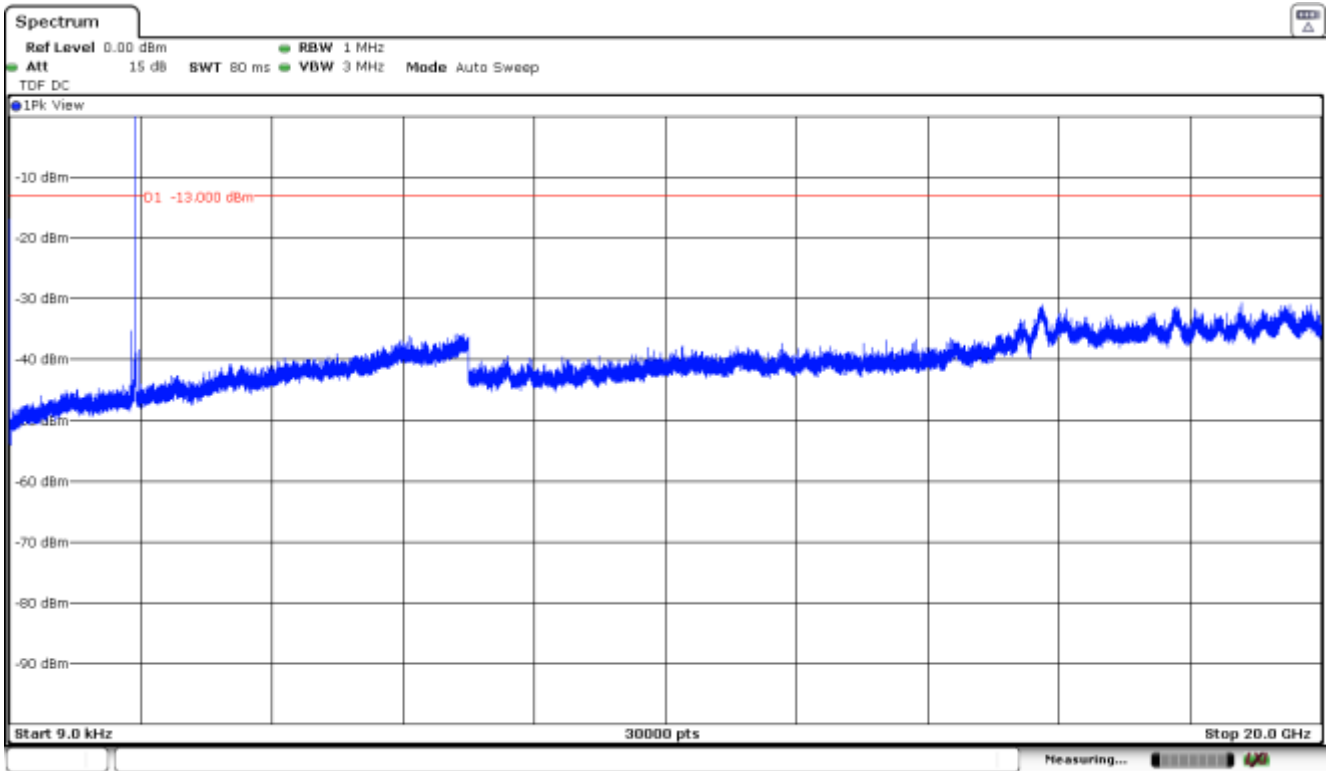

The peak above the limit is the carrier frequency.

2G Band 1900 MHz. EDGE MODULATION.

Lowest Channel:

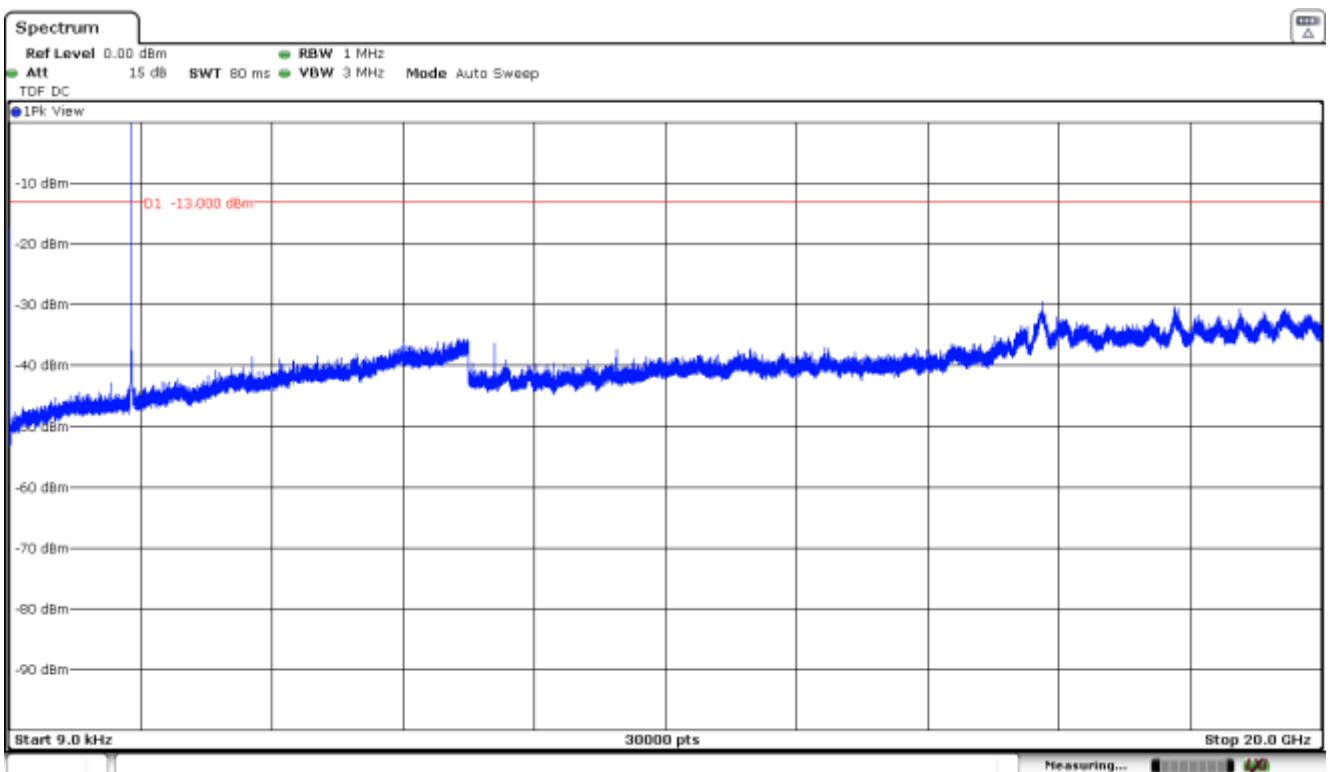

The peak above the limit is the carrier frequency.

Middle Channel:

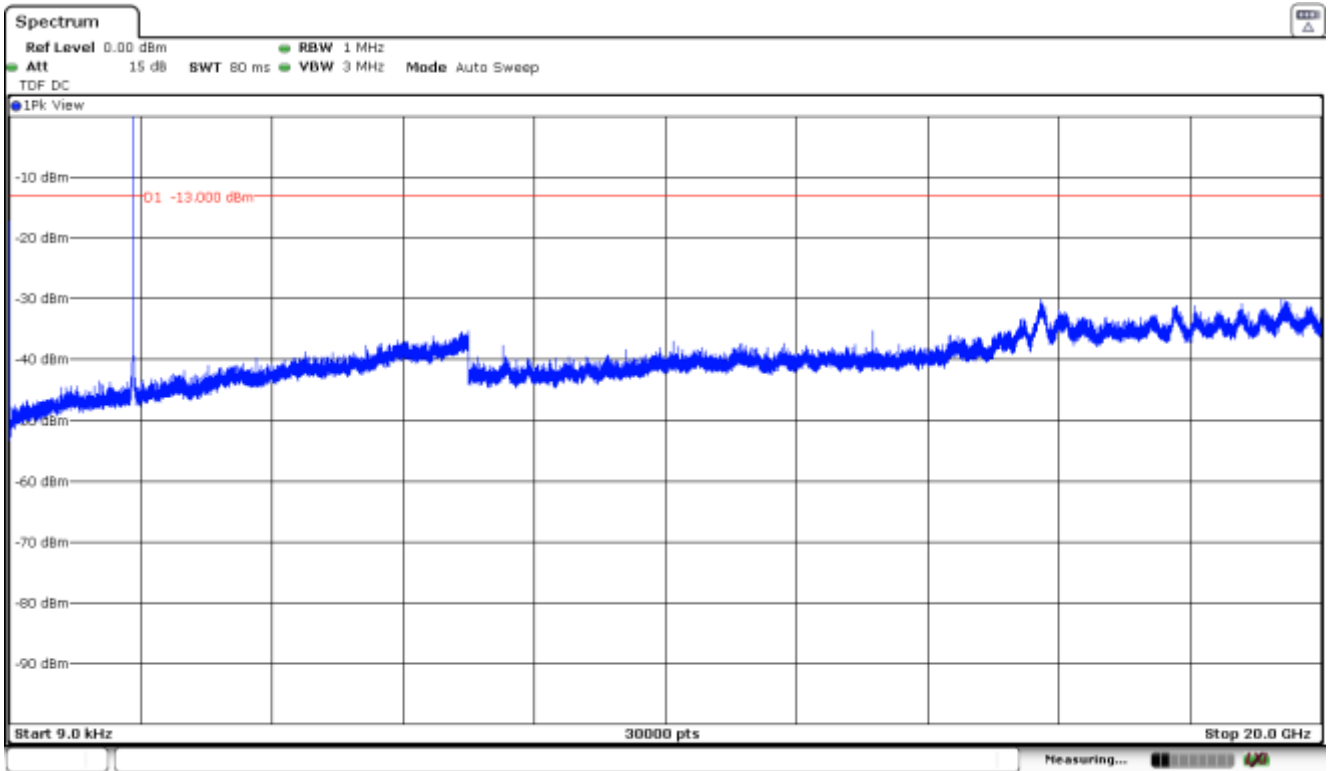

The peak above the limit is the carrier frequency.

Highest Channel:

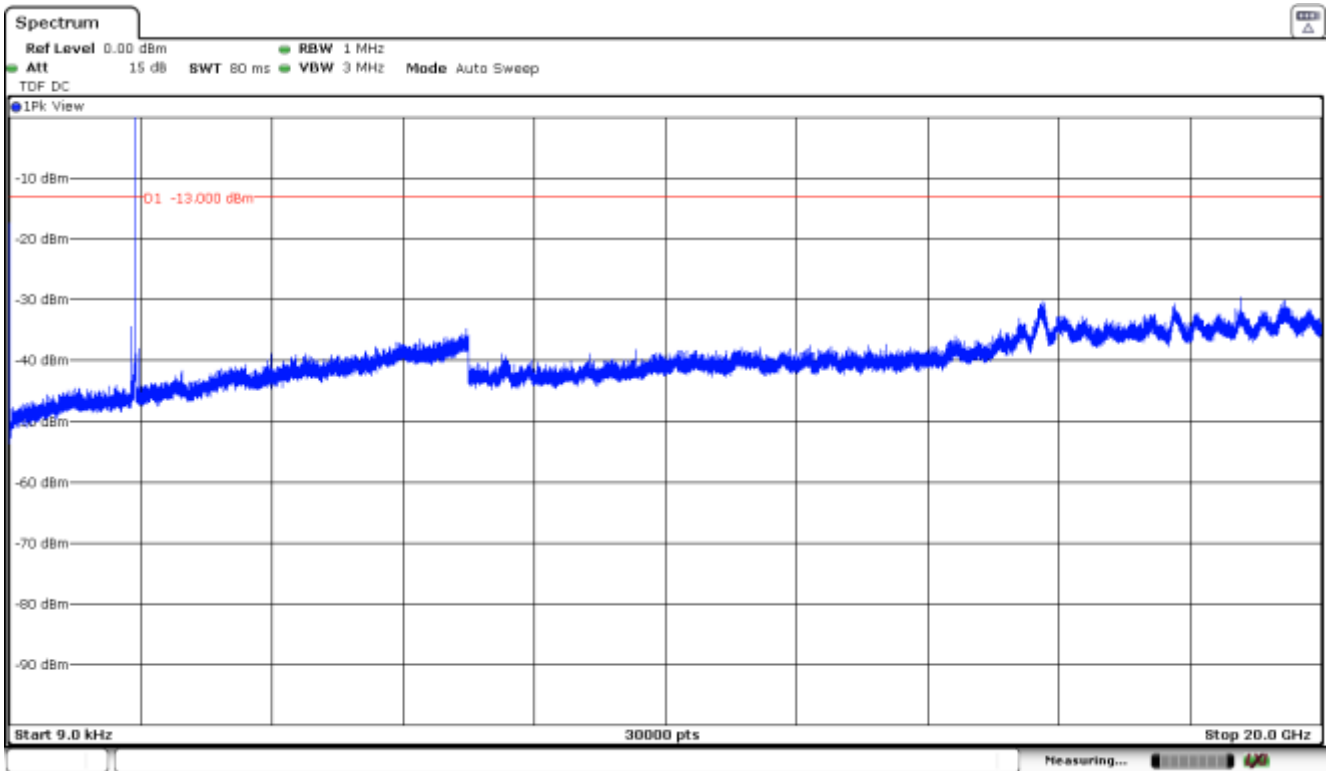

The peak above the limit is the carrier frequency.

NBLoT BAND 25 (Tone 3.75 kHz.  $\pi/2$  - BPSK MODULATION)

1. CHANNEL: LOWEST

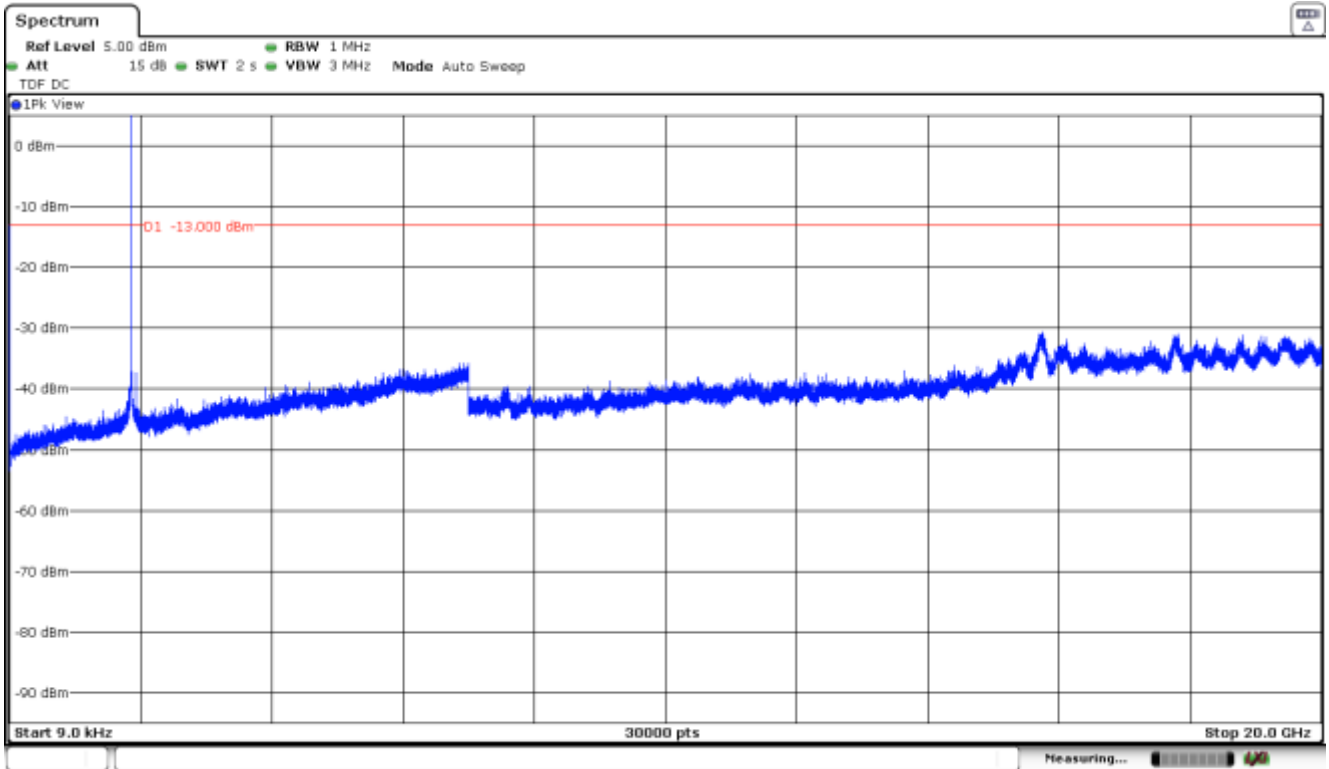

Note: The peak above the limit is the carrier frequency.

2. CHANNEL: MIDDLE

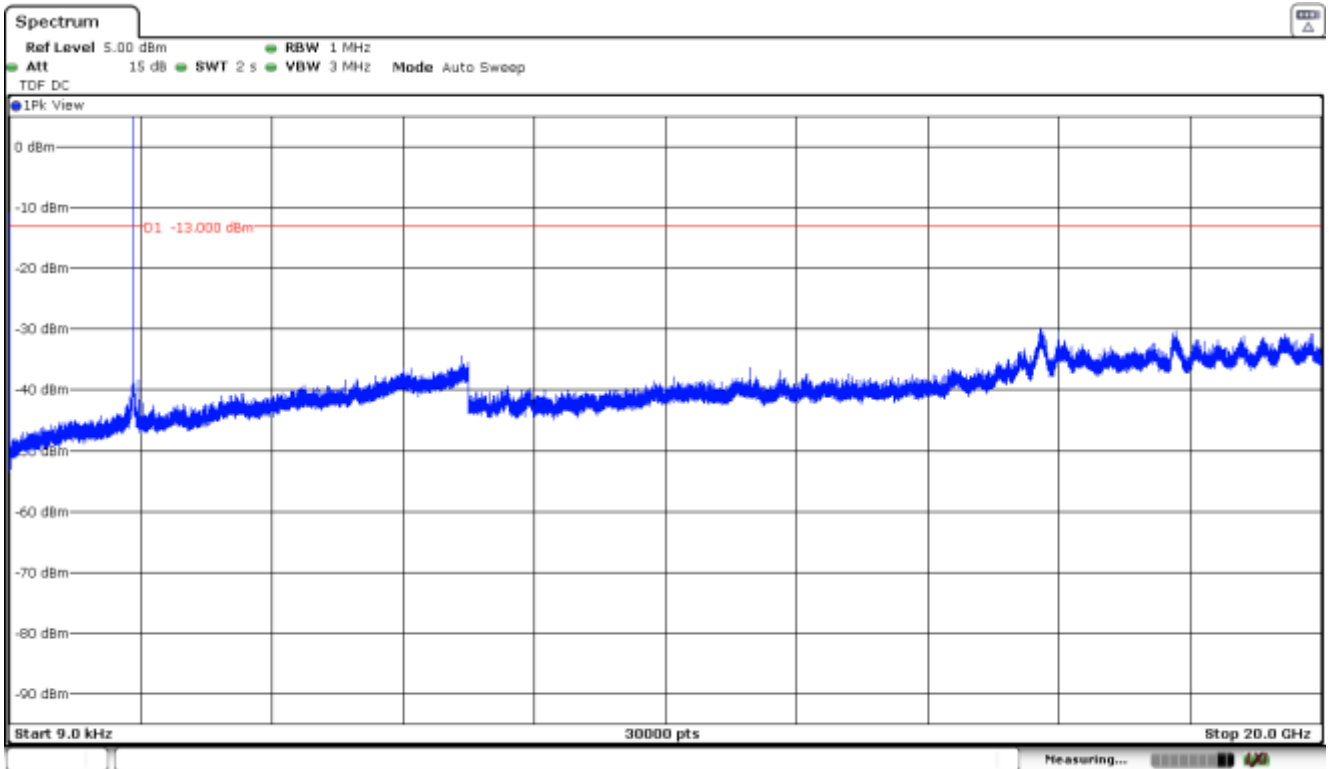

Note: The peak above the limit is the carrier frequency.

### 3. CHANNEL: HIGHEST

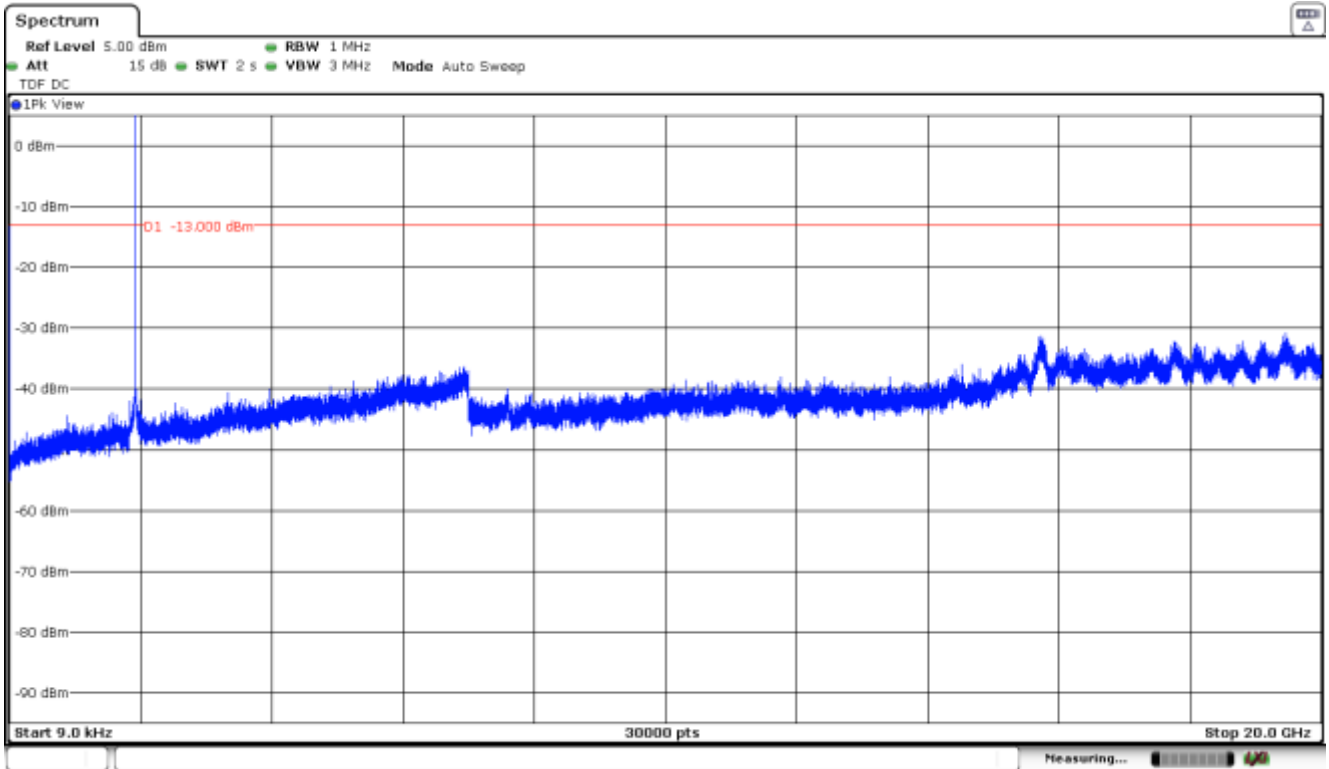

Note: The peak above the limit is the carrier frequency.

### NB IoT BAND 25 (Tone 15 kHz. $\pi/2$ - BPSK MODULATION)

#### 1. CHANNEL: LOWEST

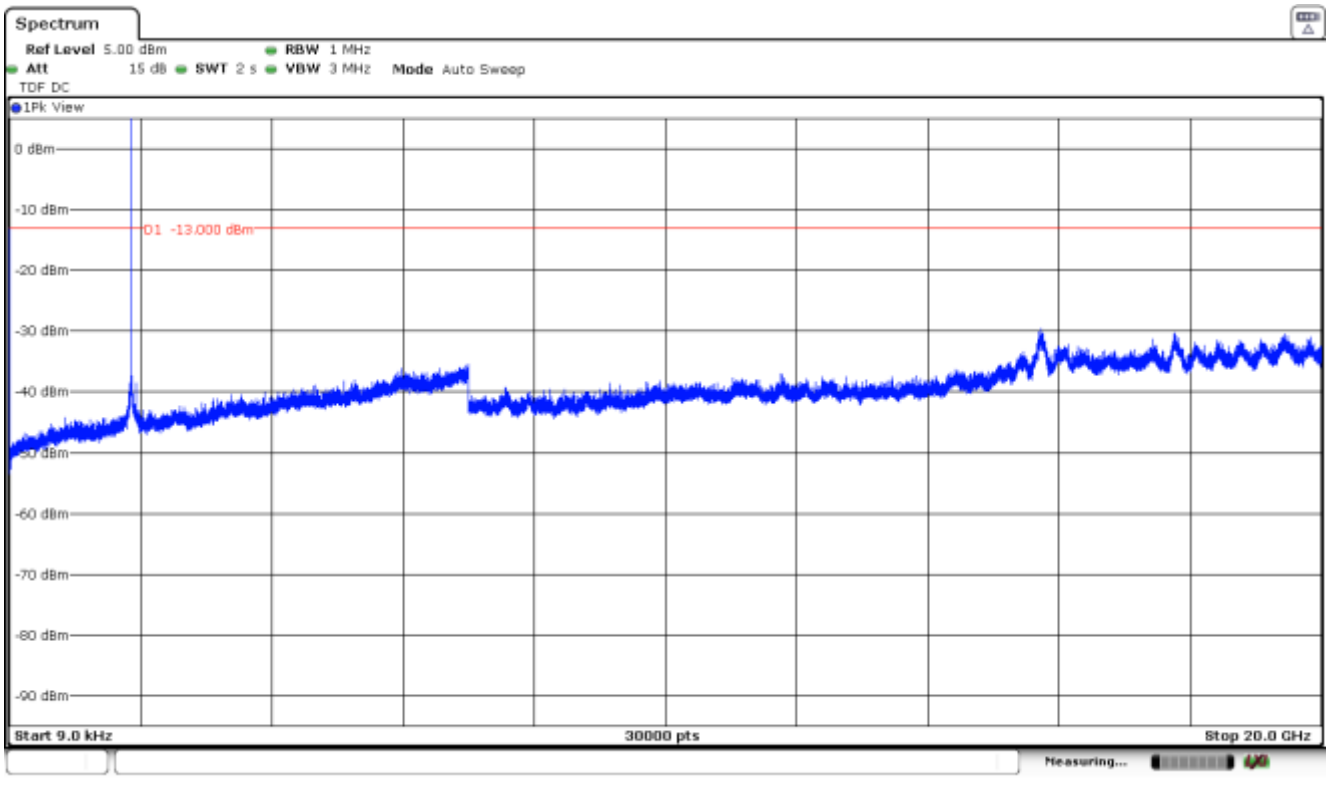

Note: The peak above the limit is the carrier frequency.

## 2. CHANNEL: MIDDLE

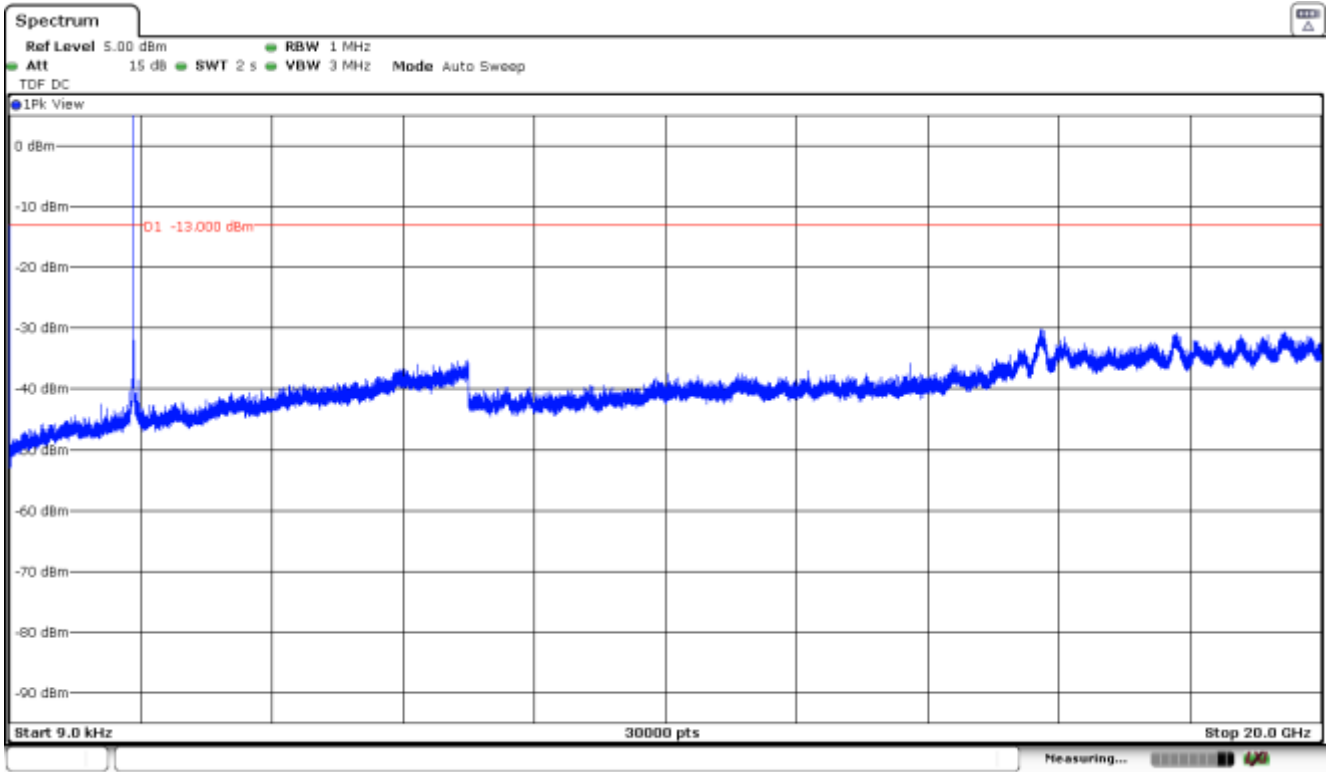

Note: The peak above the limit is the carrier frequency.

## 3. CHANNEL: HIGHEST

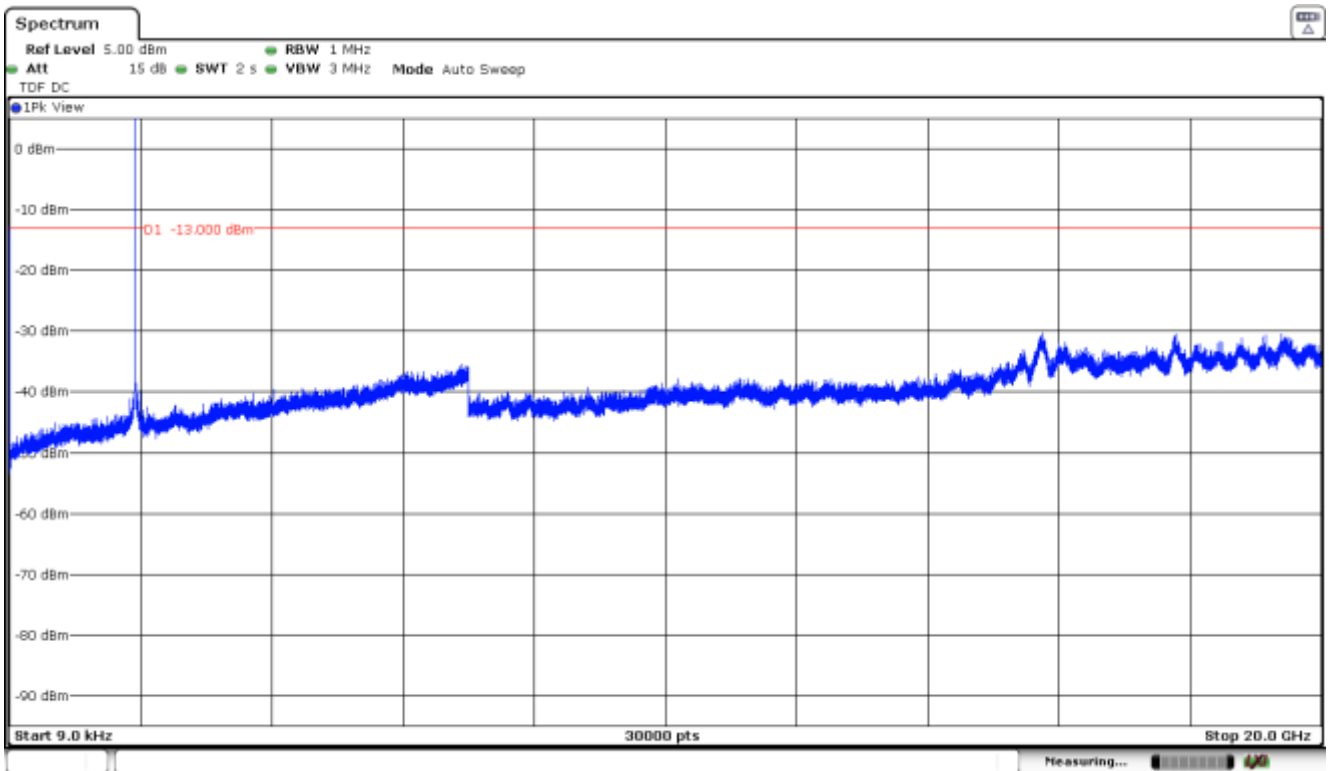

Note: The peak above the limit is the carrier frequency.

## Spurious emissions at antenna terminals at Block Edges

### SPECIFICATION:

FCC §2.1051 and §24.238. RSS-133 Clause 6.5.

### METHOD:

The EUT RF output connector was connected to a spectrum analyser and to the Universal Radio Communication tester R&S CMW500 (selecting maximum transmission power of the EUT and different modes of modulation) using a 50 ohm attenuator and a power splitter.

The reading of the spectrum analyser is corrected with the attenuation loss of connection between output terminal of EUT and input of the spectrum analyser.

As indicated in FCC part 24/RSS-133. in the 1 MHz bands immediately outside and adjacent to the frequency block or band a resolution bandwidth of at least one percent of the emission bandwidth of the fundamental emission of the transmitter may be employed.

The configuration of modulation which is the worst case for conducted power was used.

#### Measurement Limit:

According to specification. the power of emissions shall be attenuated below the transmitter power (P) by a factor of at least  $43 + 10 \log (P)$  dB. P in watts.

At  $P_o$  transmitting power. the specified minimum attenuation becomes  $43+10\log (P_o)$ . and the level in dBm relative  $P_o$  becomes:

$$P_o \text{ (dBm)} - [43 + 10 \log (P_o \text{ in mwatts}) - 30] = - 13 \text{ dBm}$$

### TEST SETUP:

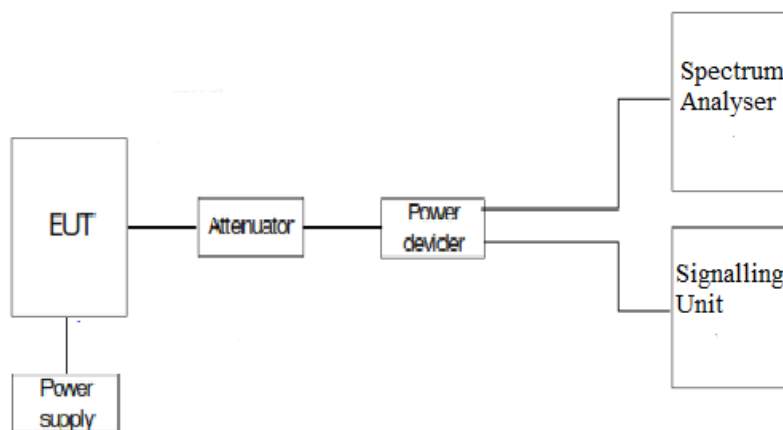



RESULTS:

2G Band 1900 MHz.

2G Band 1900 MHz	GPRS	EDGE
Maximum measured level at <u>Lowest Block Edge</u> at antenna port (dBm)	-18.11	-16.15

2G Band 1900 MHz	GPRS	EDGE
Maximum measured level at <u>Highest Block Edge</u> at antenna port (dBm)	-18.87	-18.84

NBLoT BAND 25:

NBLoT	Tone 3.75 kHz. $\pi/4$ - QPSK Offset 0 MCS/TBS=3	Tone 15kHz. $\pi/2$ - BPSK Offset 0 MCS/TBS=0	12 Tone 15kHz. $\pi/2$ - BPSK Offset 0 MCS/TBS=0
Maximum measured level at lowest Block Edge at antenna port (dBm)	-34.41	-35.95	-31.67

NBLoT	Tone 3.75 kHz. $\pi/4$ - QPSK Offset 0 MCS/TBS=3	Tone 15kHz. $\pi/2$ - BPSK Offset 0 MCS/TBS=0	12 Tone 15kHz. $\pi/2$ - BPSK Offset 0 MCS/TBS=0
Maximum measured level at highest Block Edge at antenna port (dBm)	-30.85	-35.78	-37.25

Measurement uncertainty =  $\pm 1.57$  dB.

2G Band 1900 MHz. GPRS MODULATION.

Lowest Channel:

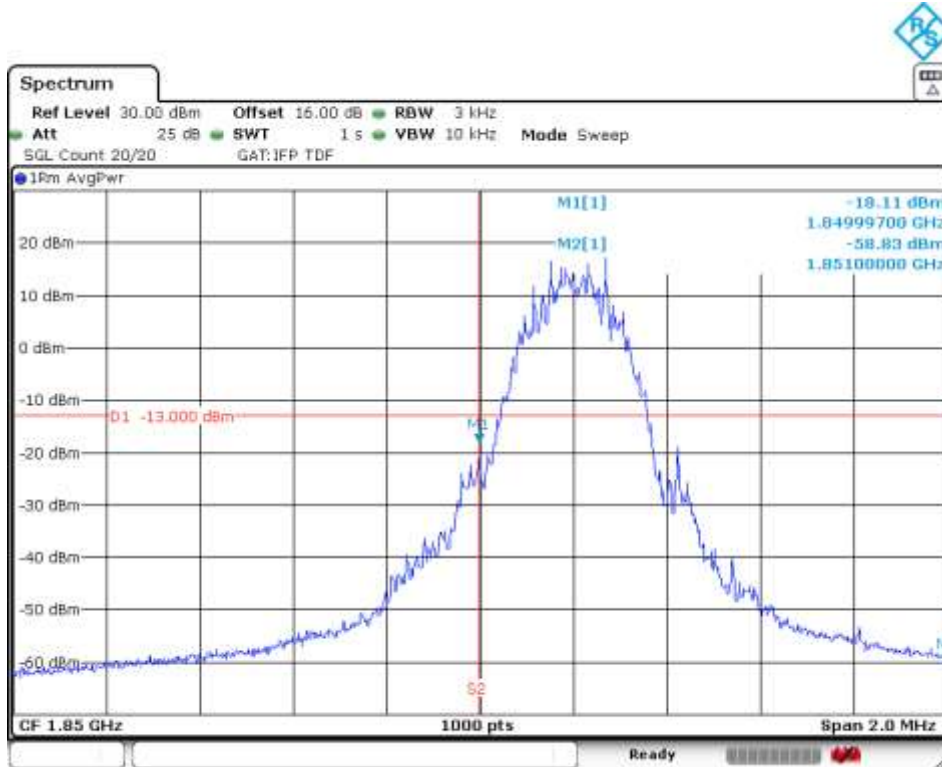

The equipment transmits at the maximum output power

Highest Channel:

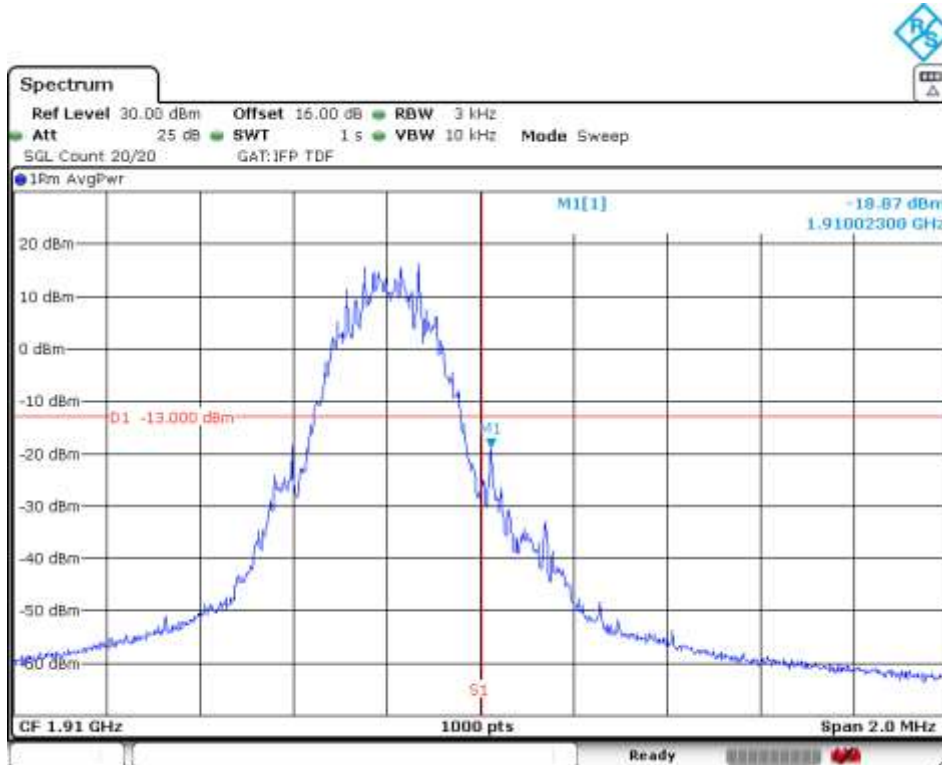

The equipment transmits at the maximum output power

2G Band 1900 MHz. EDGE MODULATION.

Lowest Channel:

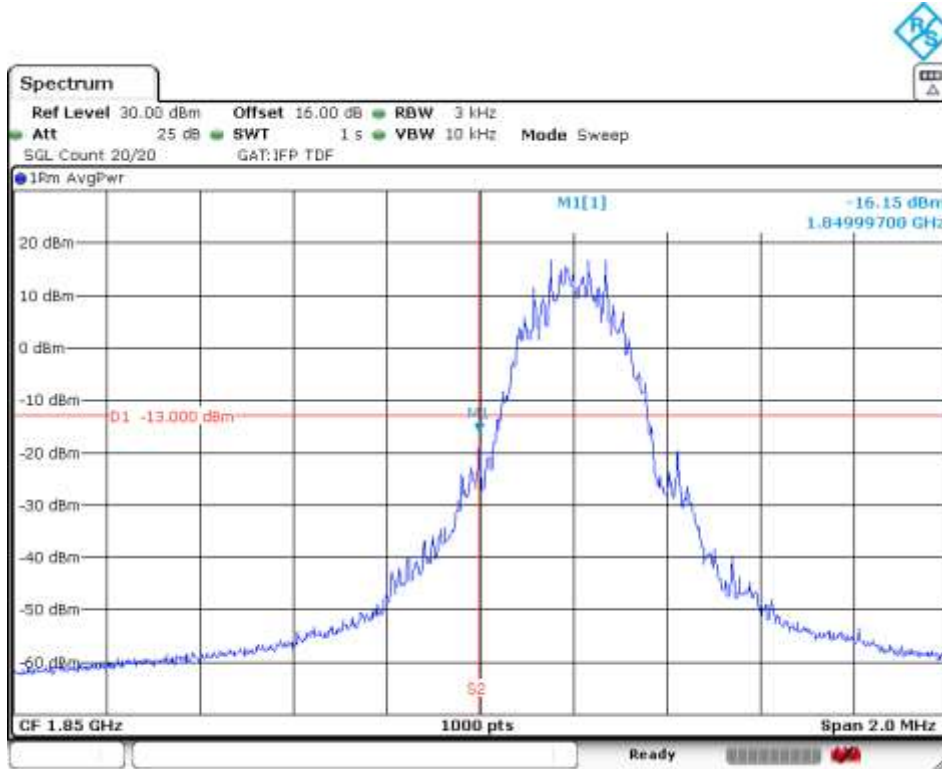

The equipment transmits at the maximum output power

Highest Channel:

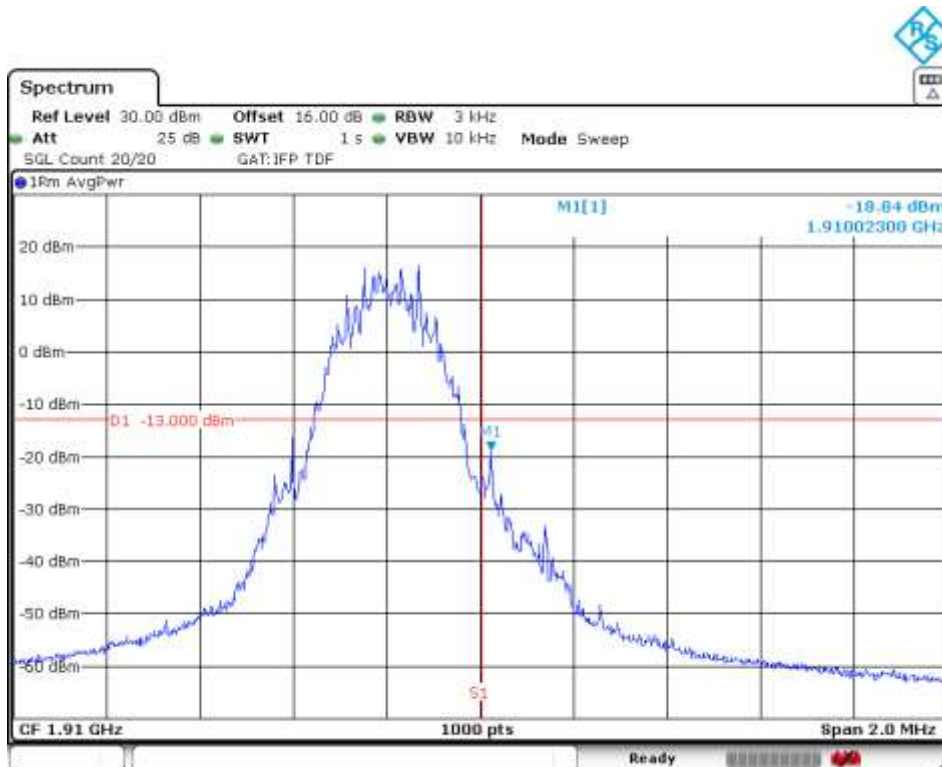

The equipment transmits at the maximum output power

NBLoT BAND 25 (Tone 3.75 kHz.  $\pi/2$  - QPSK Offset 0 MODULATION)

Lowest Channel:

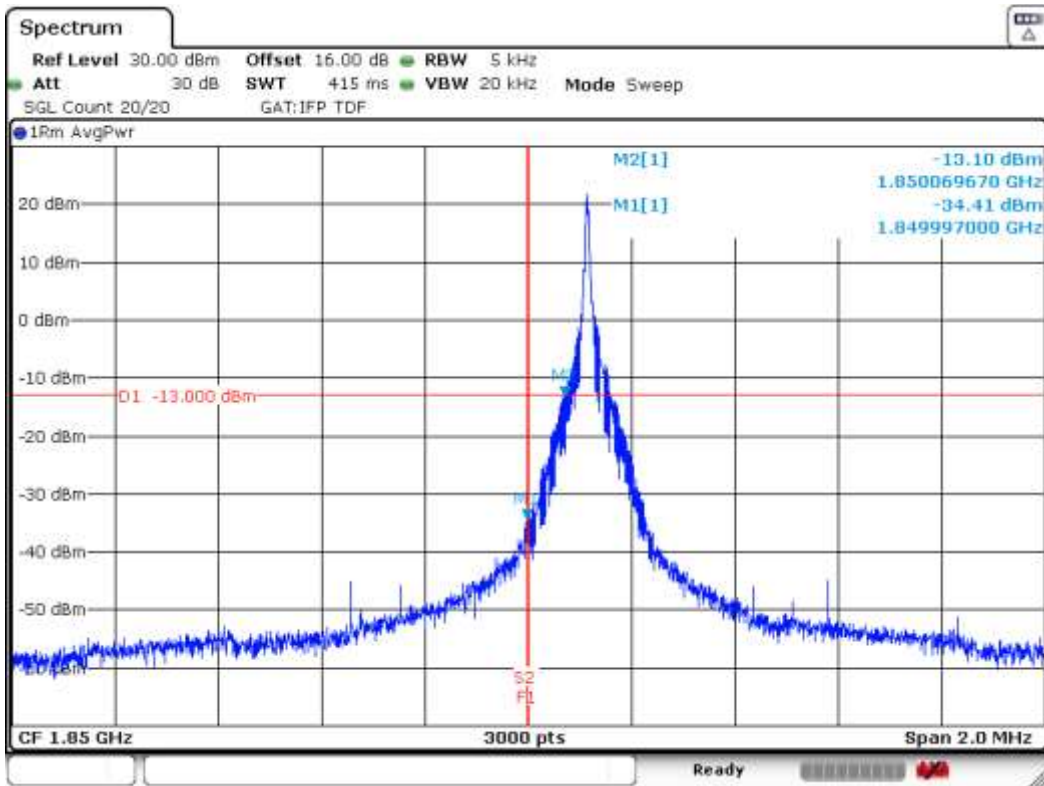

NBLoT BAND 25 (Tone 15 kHz.  $\pi/2$  - BPSK Offset 0 MODULATION)

Lowest Channel:

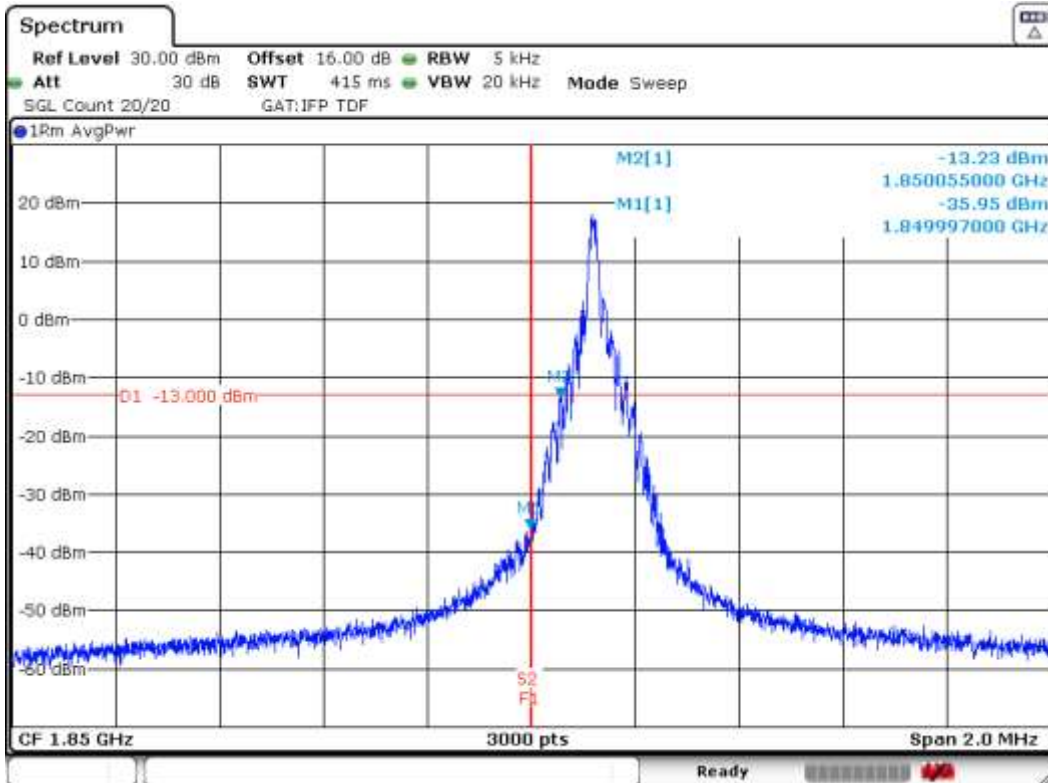

NBLoT BAND 25 (12 Tones 15 kHz.  $\pi/4$  - QPSK Offset 0 MODULATION)

Lowest Channel:

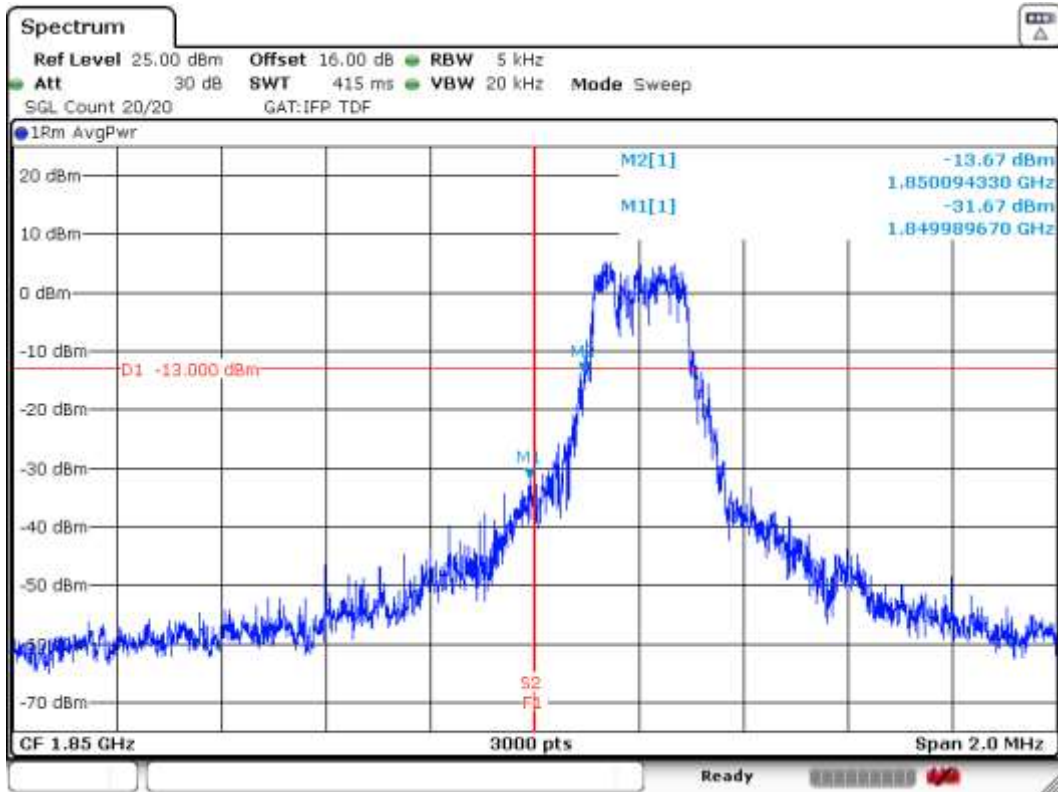

NBLoT BAND 25 (Tone 3.75 kHz.  $\pi/4$  - QPSK Offset 47 MODULATION)

Highest Channel:

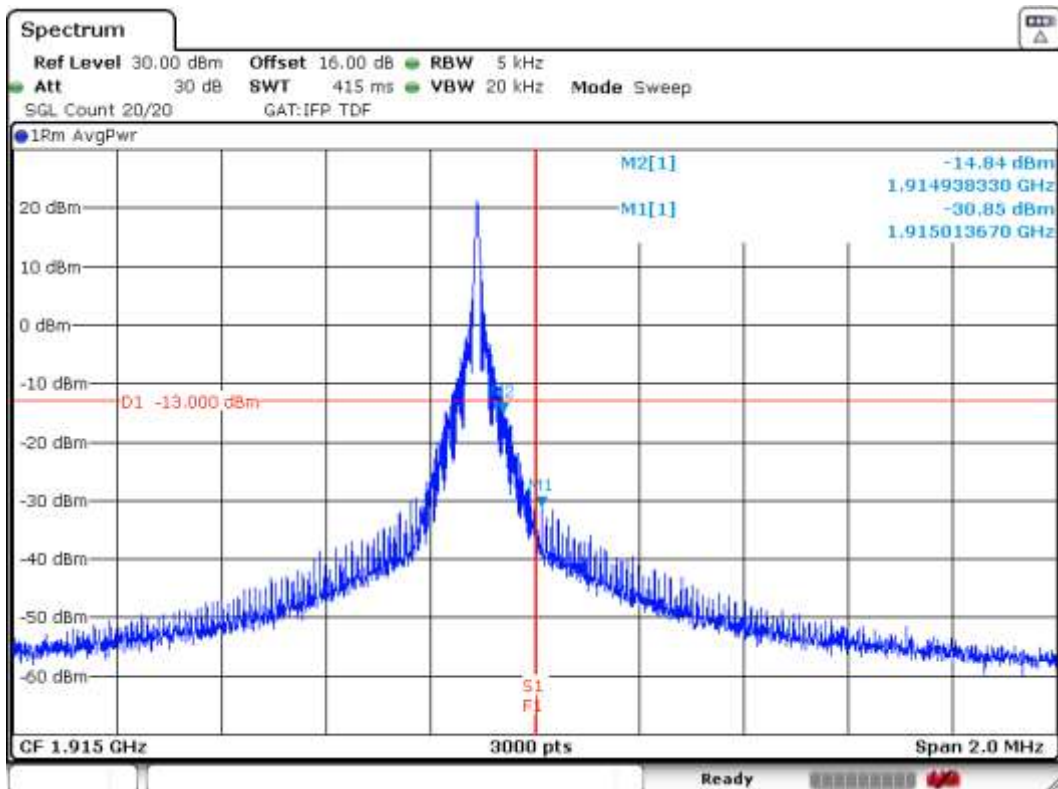

NBLoT BAND 25 (Tone 15 kHz.  $\pi/2$  - BPSK Offset 11 MODULATION)

Highest Channel:

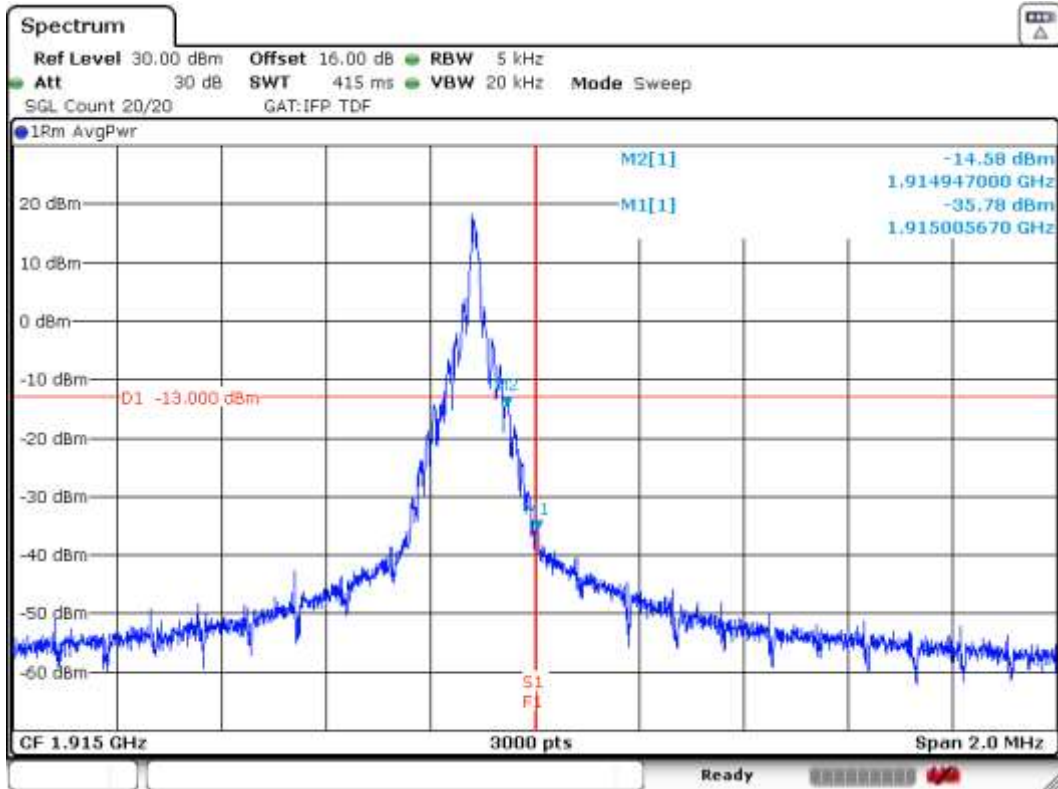

NBLoT BAND 25 (12 Tones 15 kHz.  $\pi/4$  - QPSK Offset 0 MODULATION)

Highest Channel:

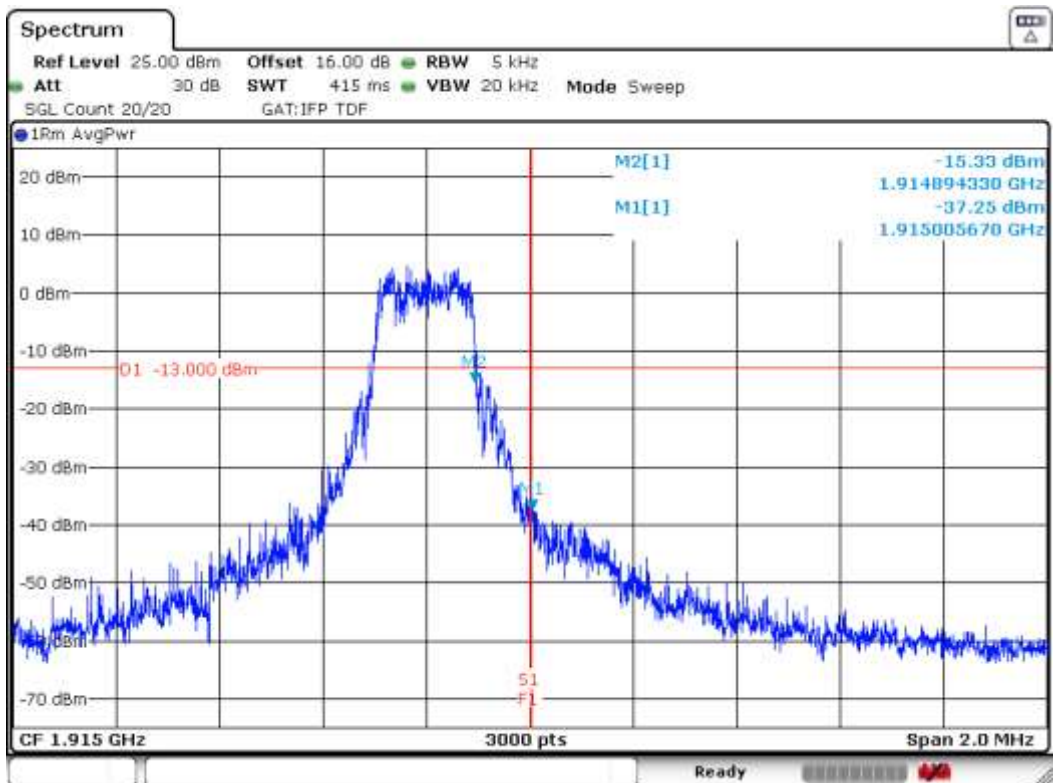

## Radiated emissions

### SPECIFICATION

FCC § 24.238. RSS-133 Clause 6.5.

The power of emissions shall be attenuated below the transmitter power (P) by a factor of at least  $43 + 10 \log (P)$  dB. P in watts.

### METHOD

The measurement was performed with the EUT inside an anechoic chamber. The spectrum was scanned from 30 MHz to at least the 10th harmonic of the highest frequency generated within the equipment. The EUT was placed on a non-conductive stand at a 3 meter distance from the measuring antenna.

Detected emissions were maximized at each frequency by rotating the EUT and adjusting the measuring antenna height and polarization. The maximum field strength (dB $\mu$ V/m) is measured and recorded.

The maximum field strength (dB $\mu$ V/m) of each detected emission at less than 20 dB respect to the limit is converted to an equivalent EIRP level (dBm) according to ANSI C63.26 with the formula:

$EIRP (dBm) = E (dB\mu V/m) + 20\log(D) - 104.8$ ; where D is the measurement distance (in the far field region) in m. D = 3 m

Measurement Limit:

According to specification. the power of emissions shall be attenuated below the transmitter power (P) by a factor of at least  $43 + 10 \log (P)$  dB. P in watts.

At  $P_o$  transmitting power. the specified minimum attenuation becomes  $43+10\log (P_o)$  and the level in dBm relative  $P_o$  becomes:

$P_o (dBm) - [43 + 10 \log (P_o \text{ in mwatts}) - 30] = - 13 \text{ dBm}$

### TEST SETUP

Radiated measurements below 1 GHz.

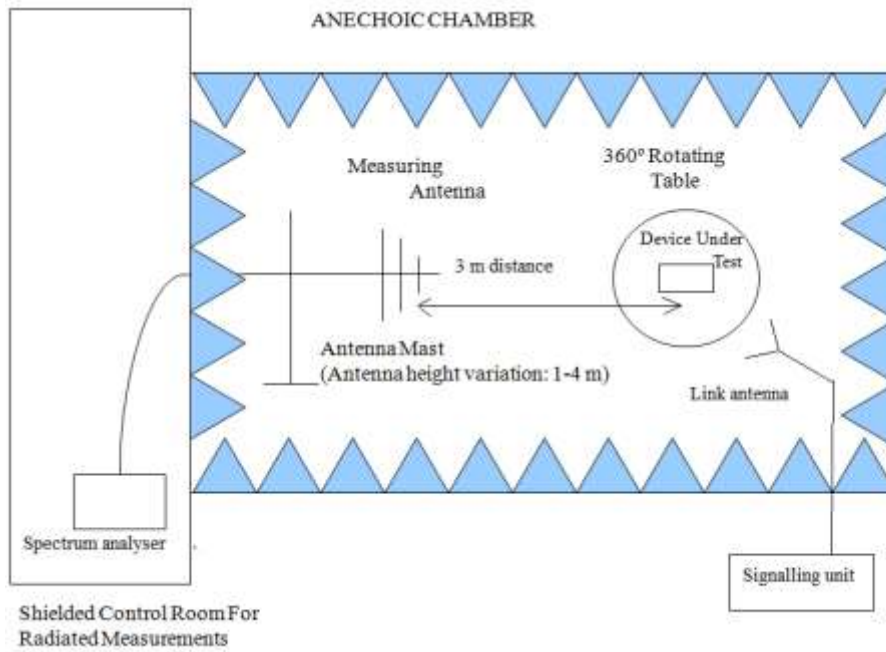

Radiated measurements between 1 GHz to 18GHz.

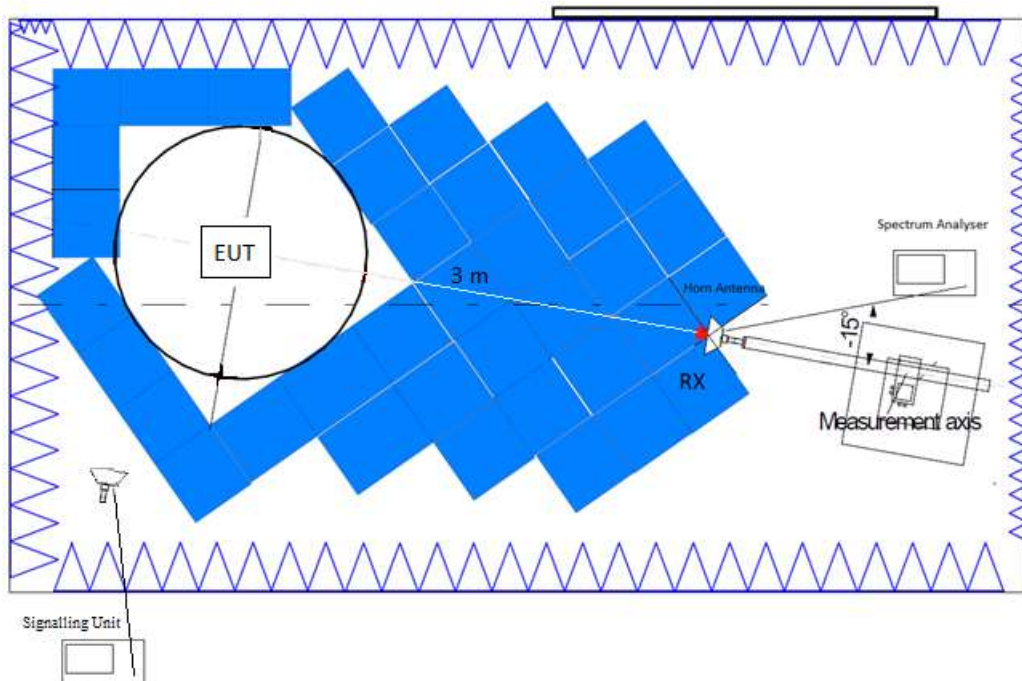



Radiated measurements above 18 GHz.

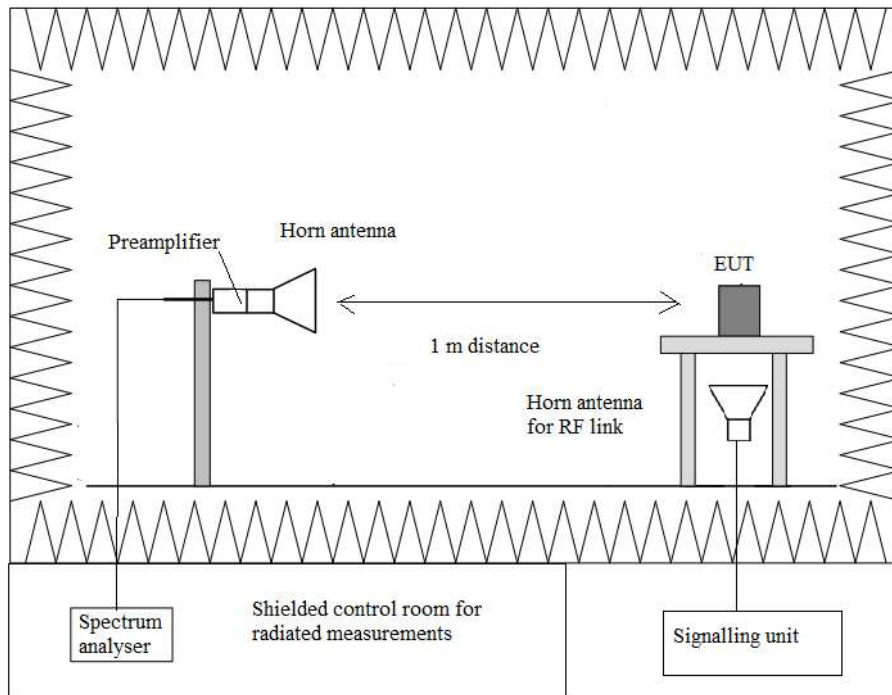

## RESULTS

### 2G Band 1900 MHz:

#### GPRS AND EDGE MODULATIONS:

A preliminary scan determined the EDGE modulation as the worst case. The following tables and plots show the results for EDGE modulation.

#### 1. CHANNEL: LOWEST

##### **Frequency range 30 MHz-1000 MHz.**

No radiated spurious signals were detected at less than 20 dB respect to the limit.

##### **Frequency range 1 GHz-18 GHz.**

No radiated spurious signals were detected at less than 20 dB respect to the limit.

##### **Frequency range 18 GHz-20 GHz.**

No radiated spurious signals were detected at less than 20 dB respect to the limit.

#### 2. CHANNEL: MIDDLE

##### **Frequency range 30 MHz-1000 MHz.**

No radiated spurious signals were detected at less than 20 dB respect to the limit.

##### **Frequency range 1 GHz-18 GHz.**

No radiated spurious signals were detected at less than 20 dB respect to the limit.

##### **Frequency range 18 GHz-20 GHz.**

No radiated spurious signals were detected at less than 20 dB respect to the limit.

#### 3. CHANNEL: HIGHEST

##### **Frequency range 30 MHz-1000 MHz.**

No radiated spurious signals were detected at less than 20 dB respect to the limit.

##### **Frequency range 1 GHz-18 GHz.**

No radiated spurious signals were detected at less than 20 dB respect to the limit.

##### **Frequency range 18 GHz-20 GHz.**

No radiated spurious signals were detected at less than 20 dB respect to the limit.

Measurement uncertainty (dB):  $<\pm 5.08$  for  $f \geq 30$  MHz up to 1 GHz  
 $<\pm 4.11$  for  $f \geq 1$  GHz up to 3 GHz  
 $<\pm 5.13$  for  $f \geq 3$  GHz up to 18 GHz  
 $<\pm 4.82$  for  $f \geq 18$  GHz up to 20 GHz

Verdict: PASS

NBLoT. BAND 25:

Preliminary measurements determined that 1 tone of 3.75kHz ( $\pi/2$  – BPSK) as the worst case. The results in the next tables shows the results for this configuration.

1. CHANNEL: LOWEST

**Frequency range 30 MHz-1000 MHz.**

No radiated spurious signals were detected at less than 20 dB respect to the limit.

**Frequency range 1 GHz-18 GHz.**

No radiated spurious signals were detected at less than 20 dB respect to the limit.

**Frequency range 18 GHz-20 GHz.**

No radiated spurious signals were detected at less than 20 dB respect to the limit.

2. CHANNEL: MIDDLE

**Frequency range 30 MHz-1000 MHz.**

No radiated spurious signals were detected at less than 20 dB respect to the limit.

**Frequency range 1 GHz-18 GHz.**

No radiated spurious signals were detected at less than 20 dB respect to the limit.

**Frequency range 18 GHz-20 GHz.**

No radiated spurious signals were detected at less than 20 dB respect to the limit.

3. CHANNEL: HIGHEST

**Frequency range 30 MHz-1000 MHz.**

No radiated spurious signals were detected at less than 20 dB respect to the limit.

**Frequency range 1 GHz-18 GHz.**

No radiated spurious signals were detected at less than 20 dB respect to the limit.

**Frequency range 18 GHz-20 GHz.**

No radiated spurious signals were detected at less than 20 dB respect to the limit.

Measurement uncertainty (dB)	< $\pm$ 4.65 for $f < 1$ GHz < $\pm$ 3.98 for $f \geq 1$ GHz up to 3 GHz < $\pm$ 4.98 for $f \geq 3$ GHz up to 17 GHz < $\pm$ 5.33 for $f \geq 17$ GHz up to 20 GHz
------------------------------	--

Verdict: PASS

### FREQUENCY RANGE 30 MHz-1000 MHz.

CHANNEL: LOWEST

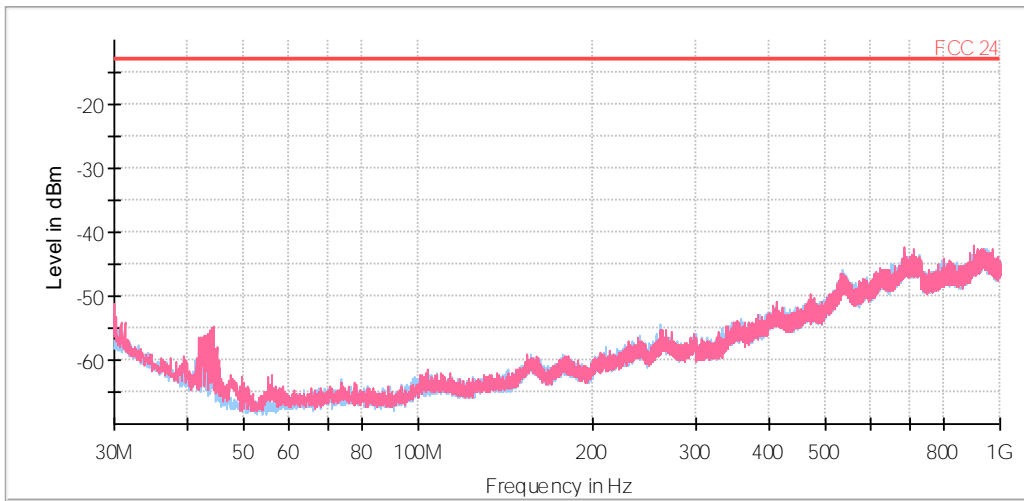

Preview Result 1H-PK+      Preview Result 1V-PK+      \* Critical\_Freqs PK+  
FCC 24      Final\_Result PK+

CHANNEL: MIDDLE

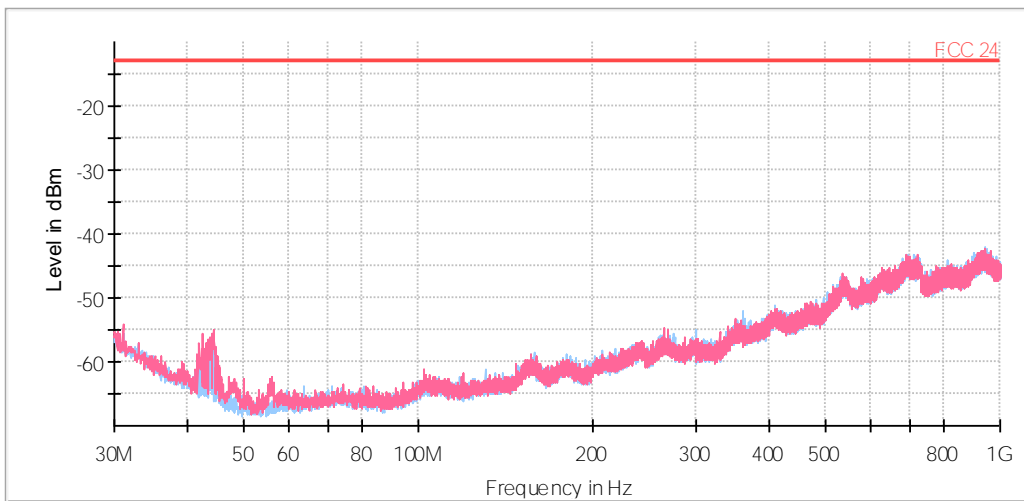

Preview Result 1H-PK+      Preview Result 1V-PK+      \* Critical\_Freqs PK+  
FCC 24      Final\_Result PK+

CHANNEL: HIGHEST

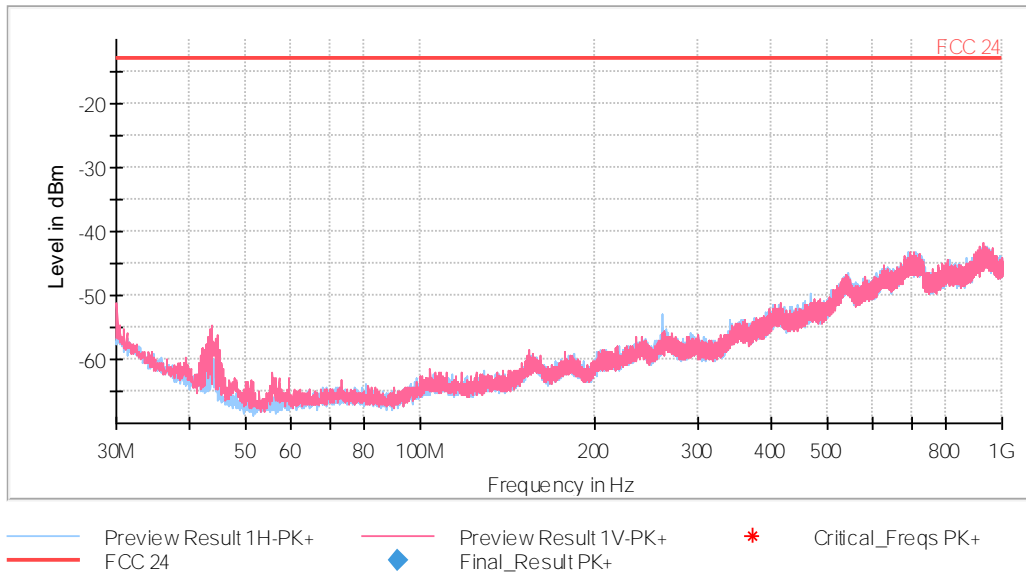

Frequency range 1 GHz to 3 GHz

CHANNEL: LOWEST

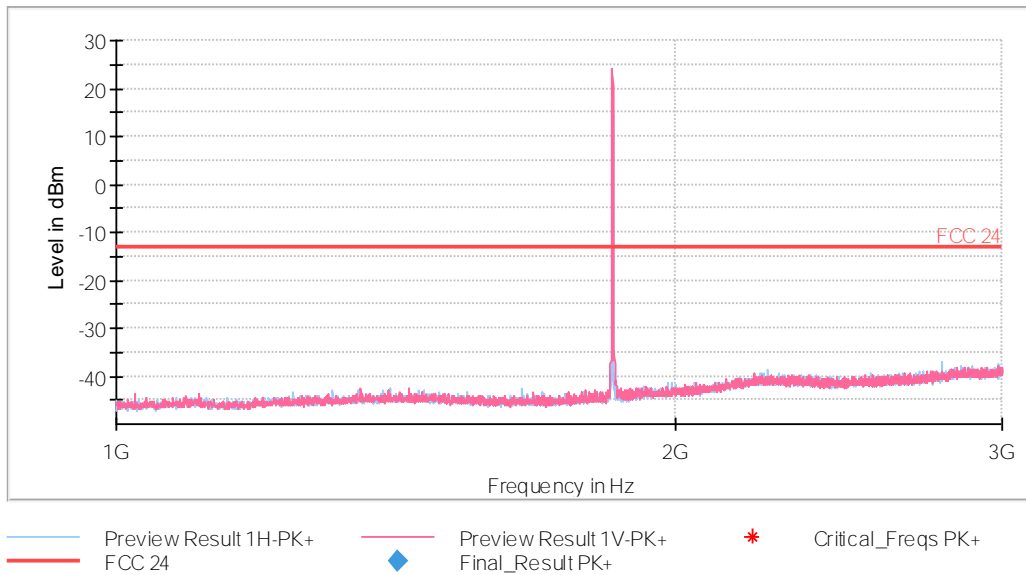

The peak above the limit is the carrier frequency.

CHANNEL: MIDDLE

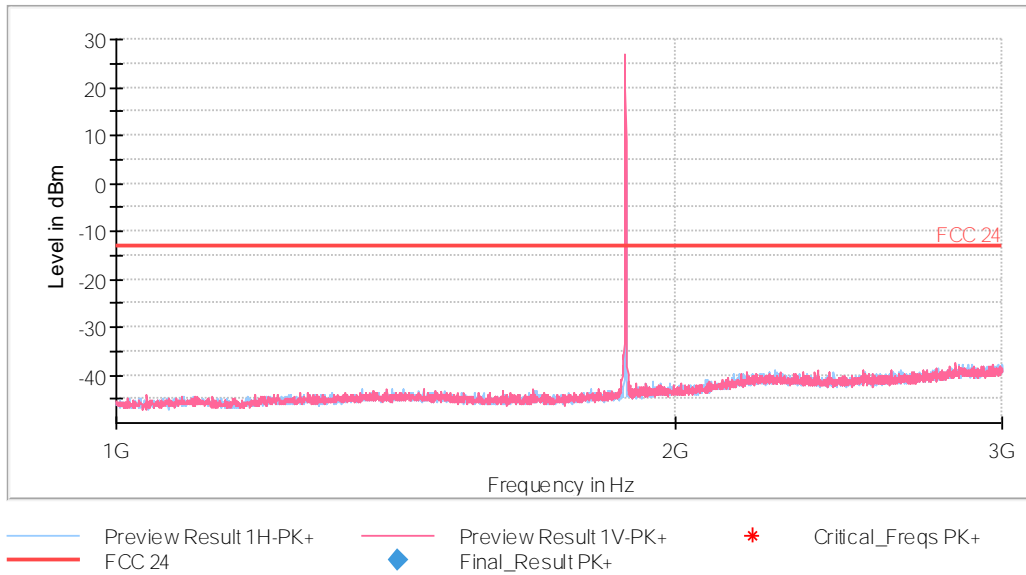

The peak above the limit is the carrier frequency.

CHANNEL: HIGHEST

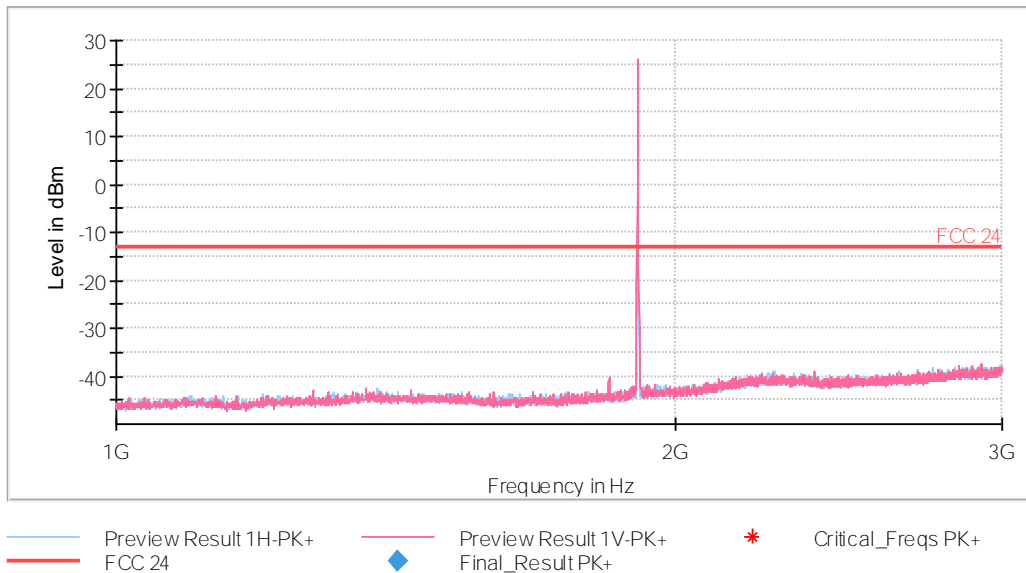

The peak above the limit is the carrier frequency.

Frequency range 3 GHz to 18 GHz

CHANNEL: LOWEST

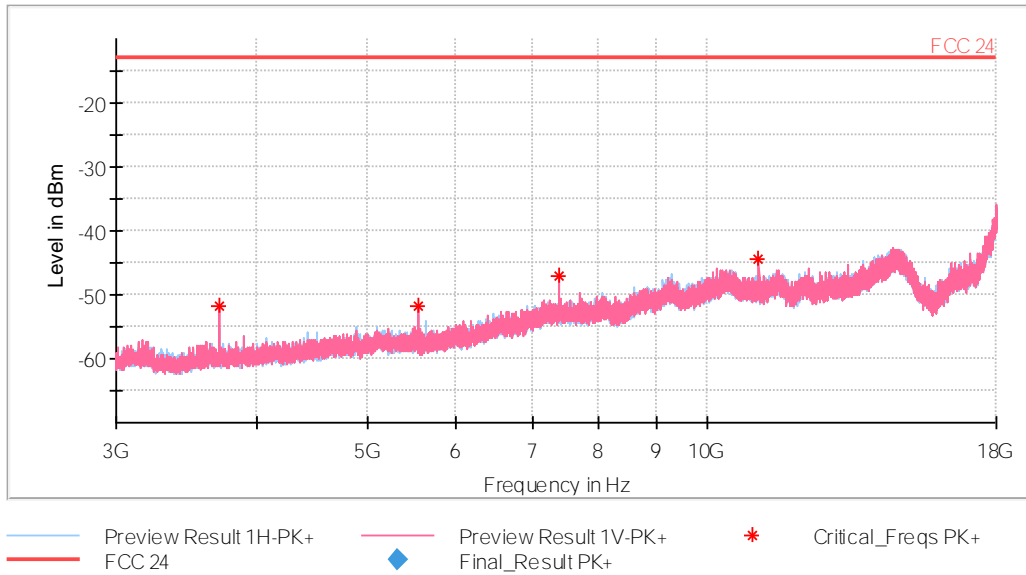

CHANNEL: MIDDLE

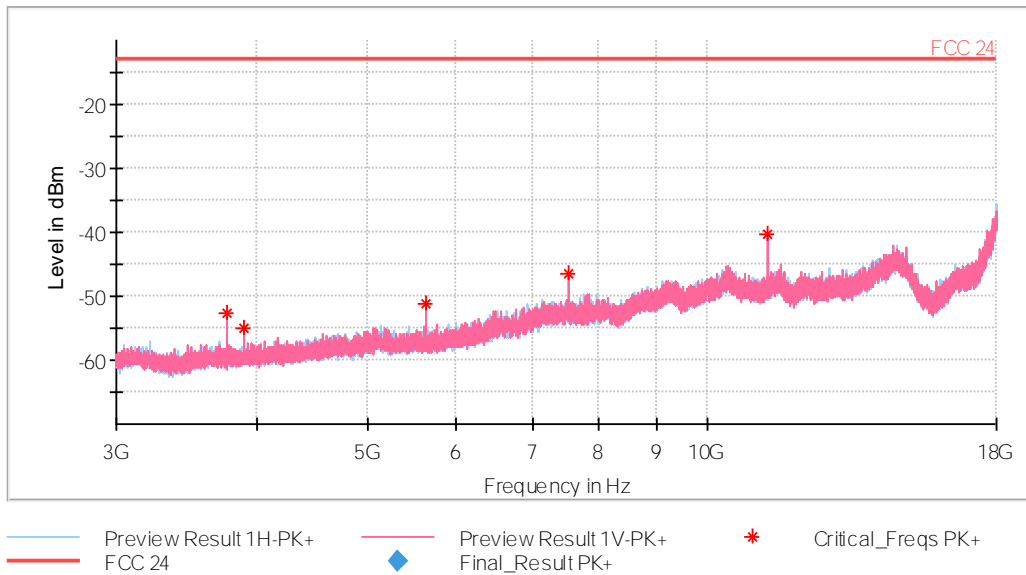

CHANNEL: HIGHEST

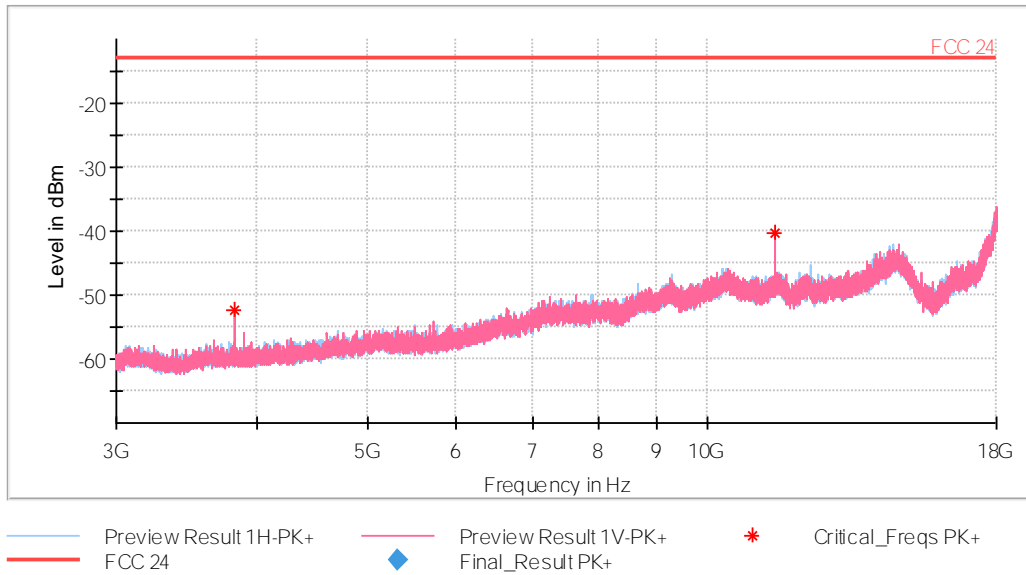

FREQUENCY RANGE 18 - 20 GHz

CHANNEL: LOWEST

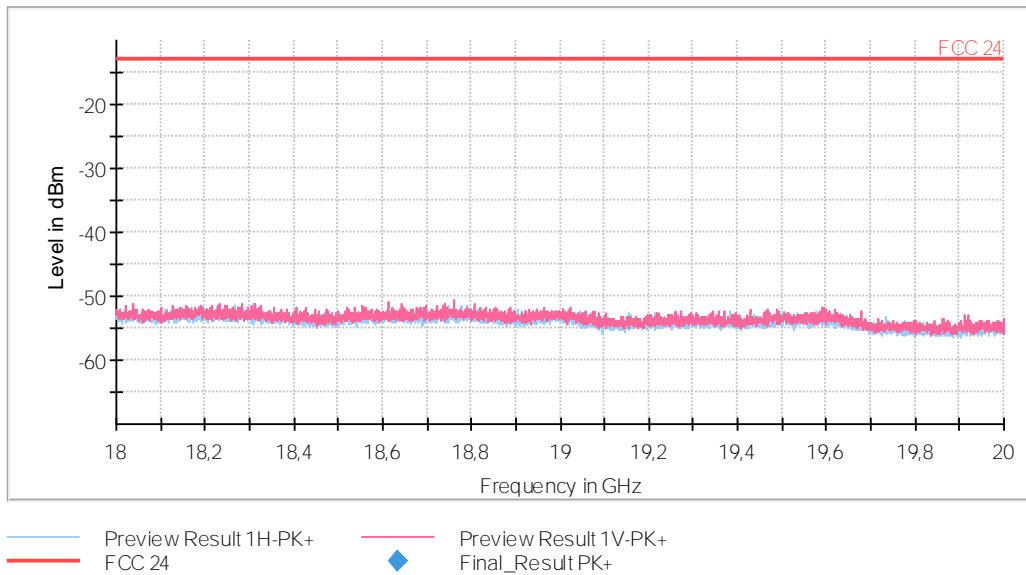



CHANNEL: MIDDLE

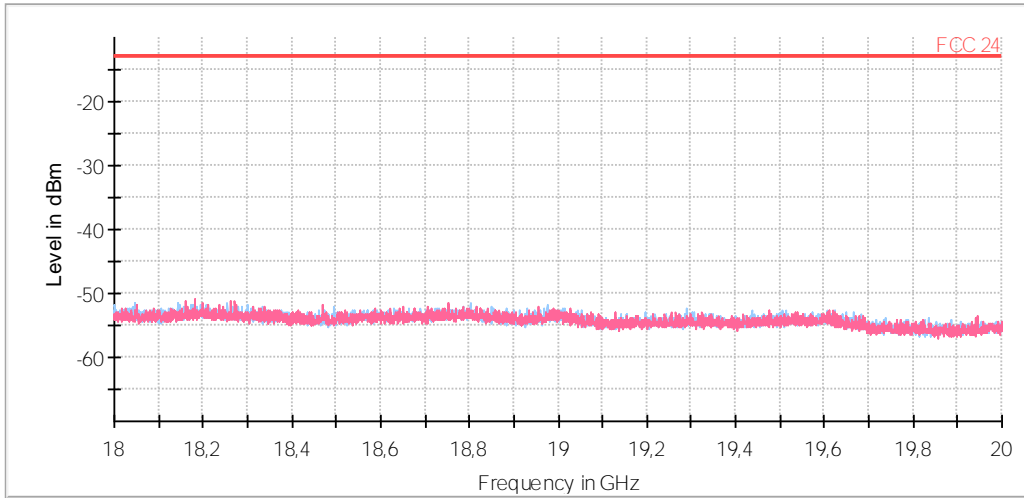

CHANNEL: HIGHEST

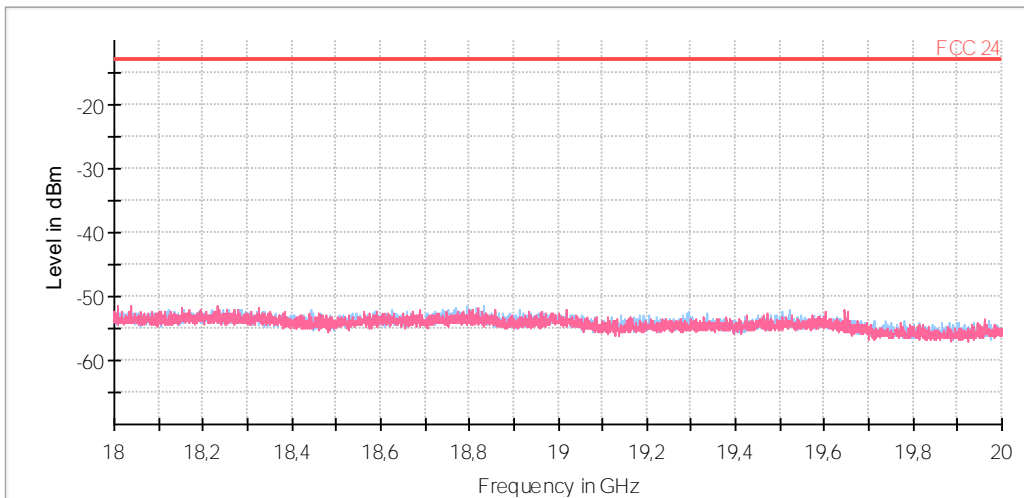

NB IoT. BAND 25:

FREQUENCY RANGE 30 MHz-1000 MHz.

CHANNEL: LOWEST

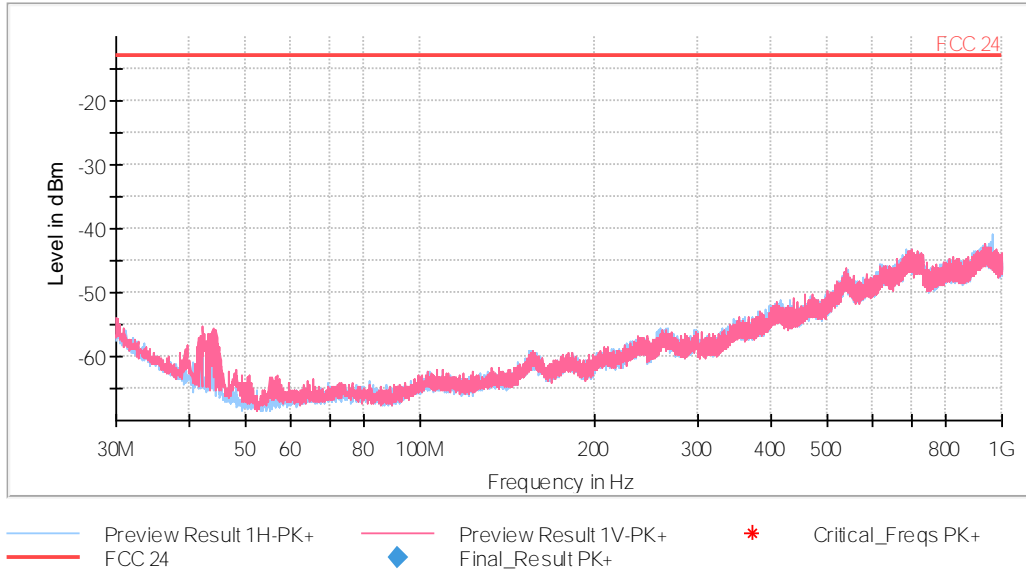

CHANNEL: MIDDLE

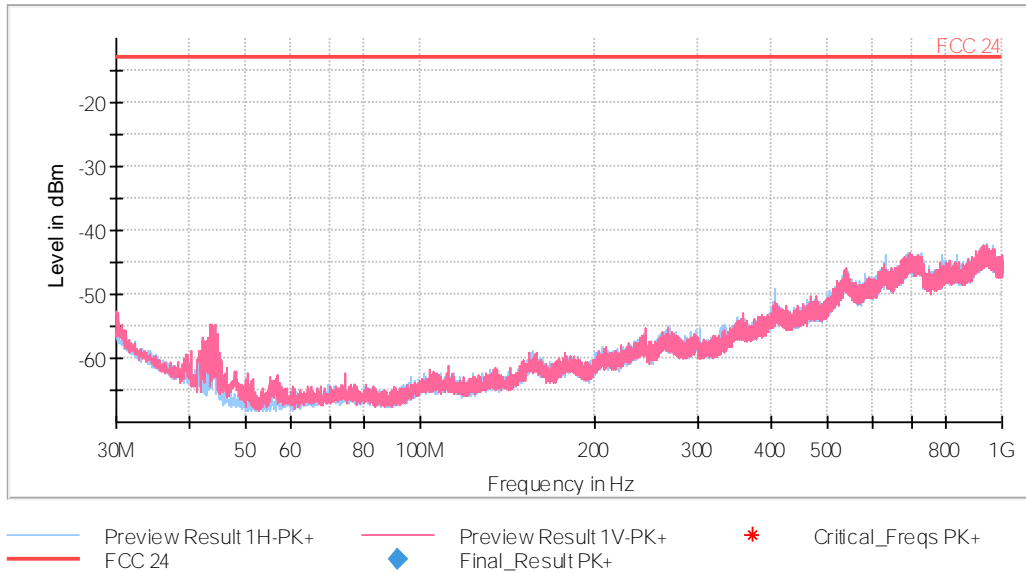

CHANNEL: HIGHEST

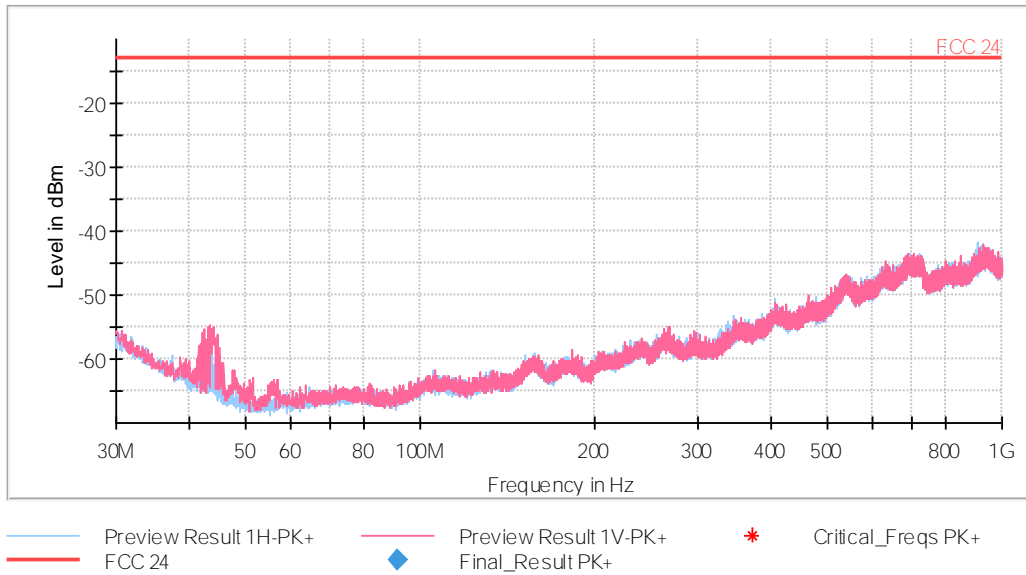

Frequency range 1 GHz to 3 GHz

CHANNEL: LOWEST

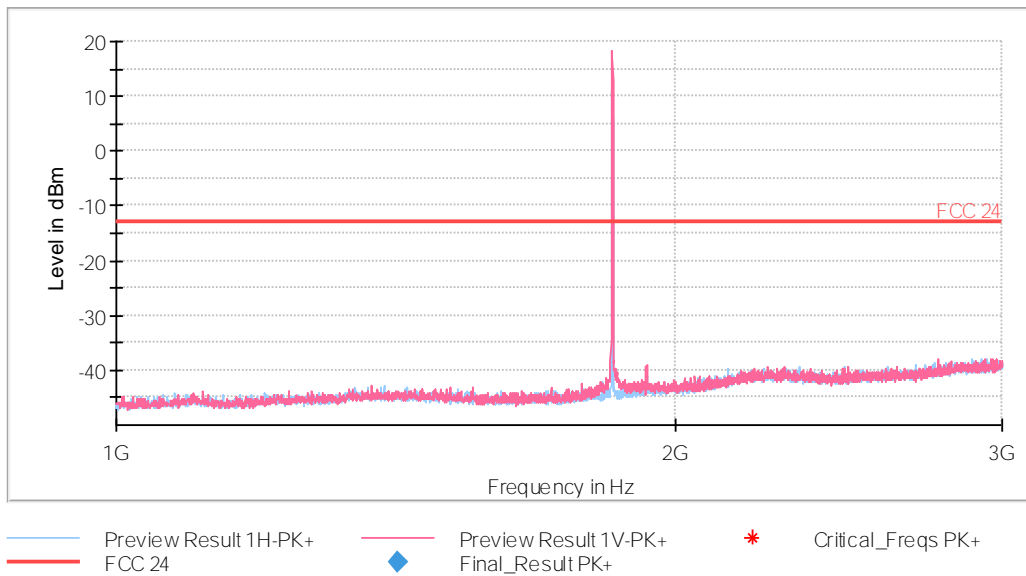

Note: The peak above the limit is the carrier frequency.

CHANNEL: MIDDLE

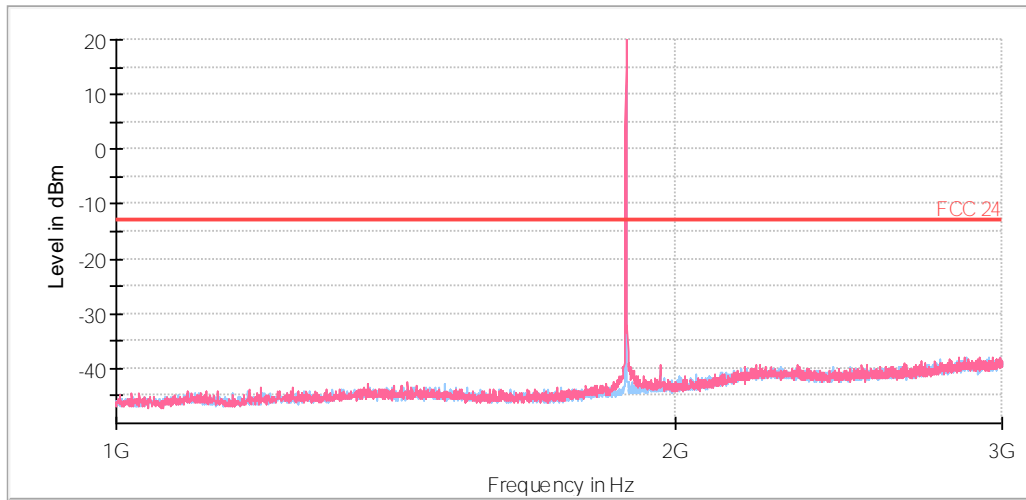

— Preview Result 1H-PK+      — Preview Result 1V-PK+      \* Critical\_Freqs PK+  
— FCC 24      ◆ Final\_Result PK+

Note: The peak above the limit is the carrier frequency.

CHANNEL: HIGHEST

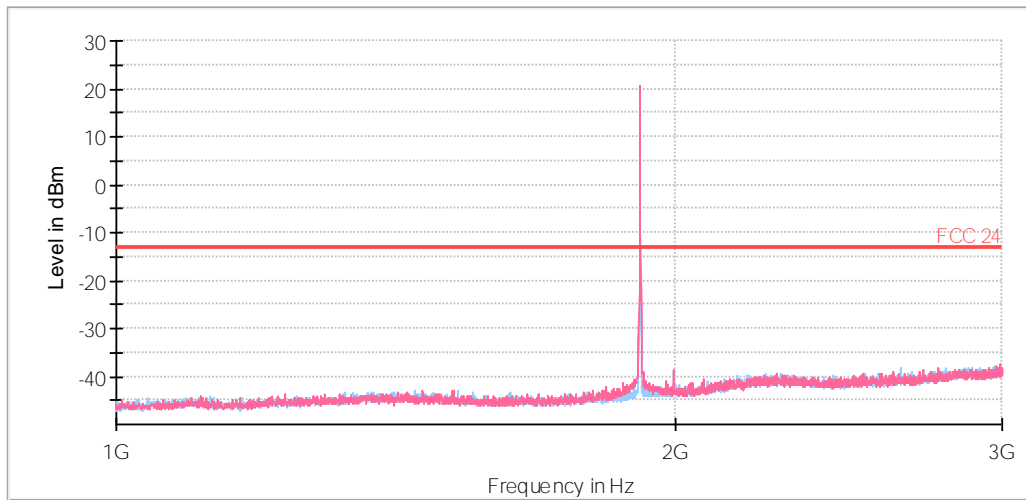

— Preview Result 1H-PK+      — Preview Result 1V-PK+      \* Critical\_Freqs PK+  
— FCC 24      ◆ Final\_Result PK+

Note: The peak above the limit is the carrier frequency.

Frequency range 3 GHz to 18 GHz

CHANNEL: LOWEST

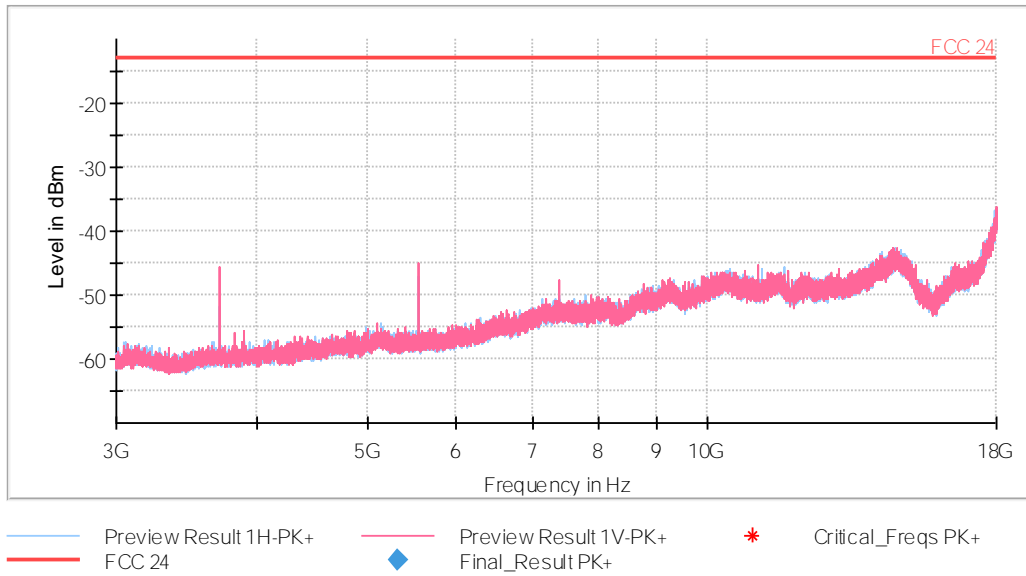

CHANNEL: MIDDLE

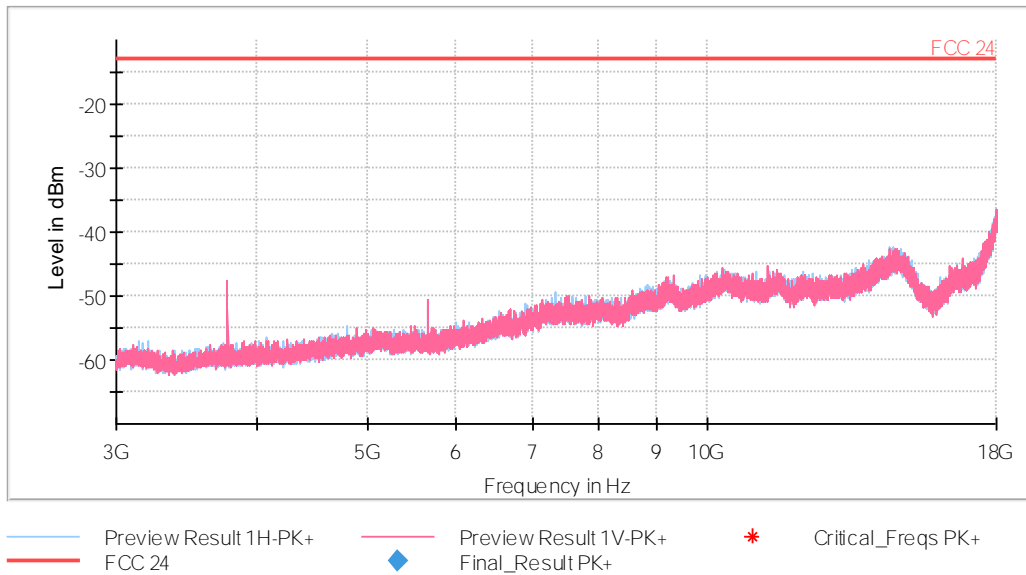

CHANNEL: HIGHEST

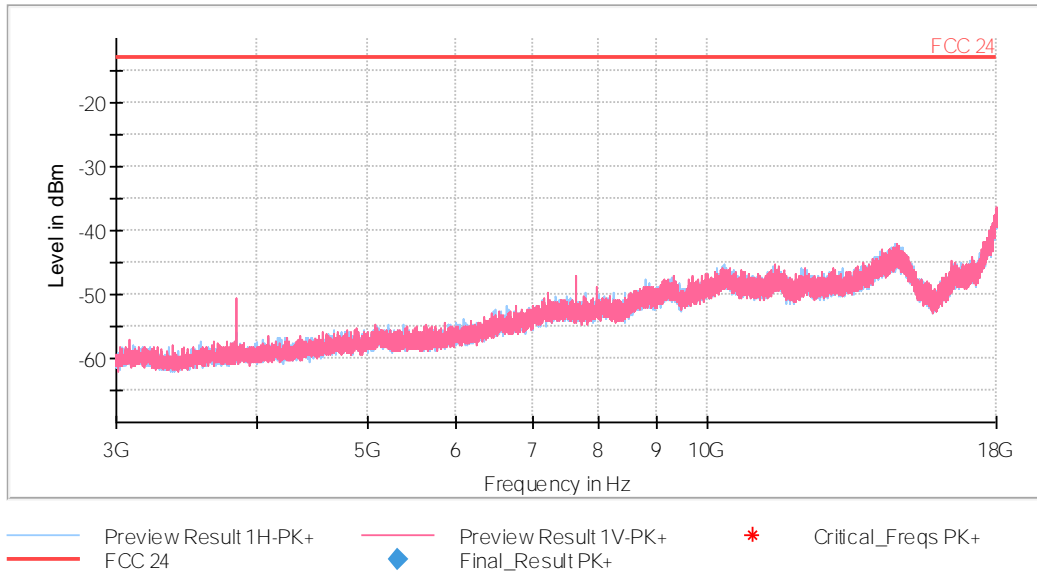

Frequency range 18 GHz to 20 GHz

CHANNEL: LOWEST

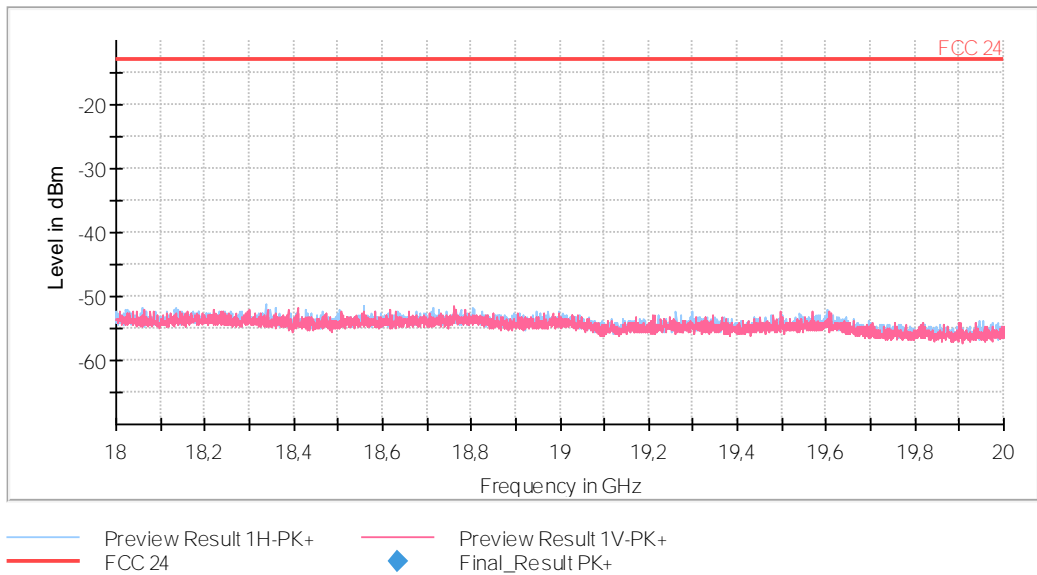

CHANNEL: MIDDLE

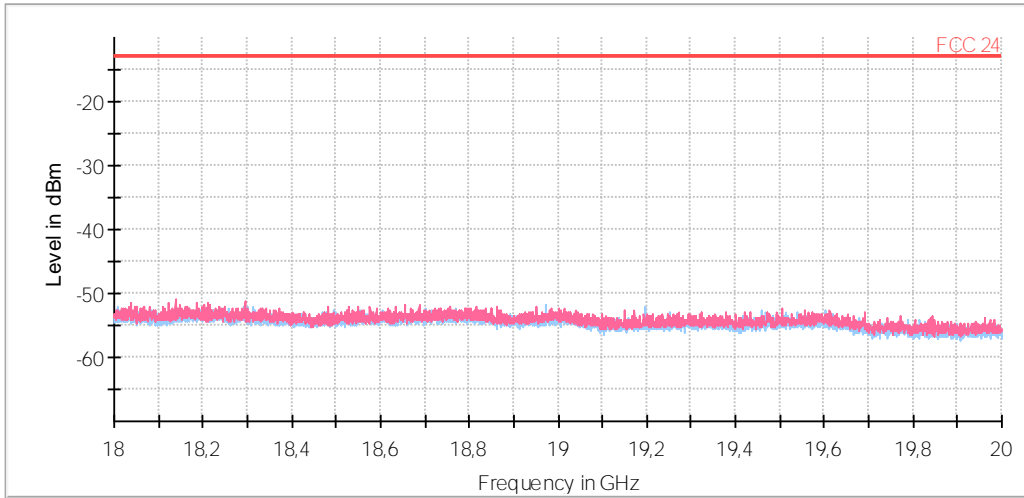

— Preview Result 1H-PK+      — Preview Result 1V-PK+  
— FCC 24      ◆ Final\_Result PK+

CHANNEL: HIGHEST

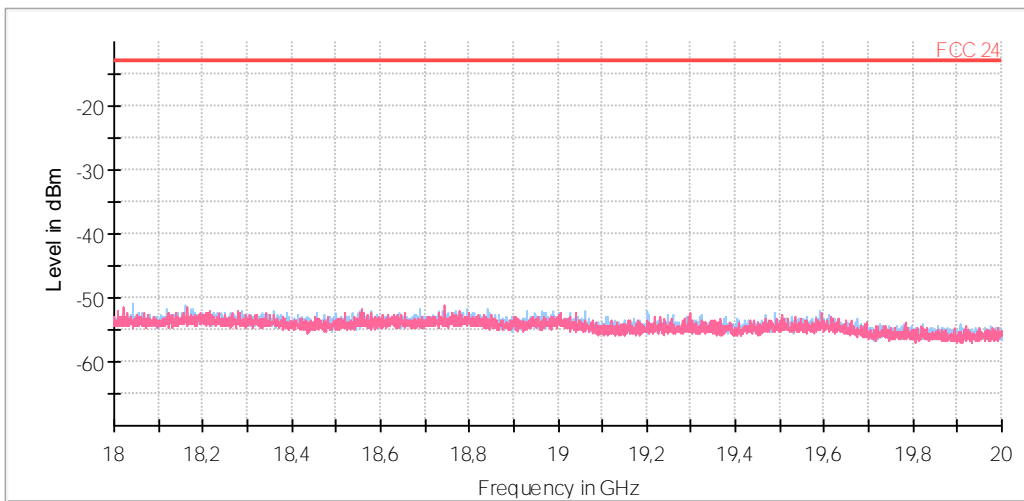

— Preview Result 1H-PK+      — Preview Result 1V-PK+  
— FCC 24      ◆ Final\_Result PK+

## Appendix C: Test results for FCC Part 27 / RSS-139 / RSS-130



## INDEX

TEST CONDITIONS.....	161
RF Output Power .....	163
Frequency Stability .....	179
Modulation Characteristics.....	185
Occupied Bandwidth .....	190
Spurious emissions at antenna terminals.....	218
Spurious emissions at antenna terminals at Block Edges.....	237
Radiated emissions .....	252

## TEST CONDITIONS

Vnominal = 3.8 Vdc

Type of power supply = DC Voltage from external power supply

Type of antenna = external antenna.

Declared Gain for antenna = +2.15dBi for all bands.

### TEST FREQUENCIES:

NBLoT.  $\pi/2$  - BPSK AND  $\pi/4$  - QPSK MODULATION (BAND 4)

Channel (Frequency. MHz)		
Lowest	Middle	Highest
19952 (1710.2)	20175 (1732.5)	20398 (1754.8)

NOTE: Band 4 is completely included in band 66. so the channels of band 66 were tested to give conformity to the assigned block

NBLoT.  $\pi/2$  - BPSK AND  $\pi/4$  - QPSK MODULATION (BAND 12)

Channel (Frequency. MHz)		
Lowest	Middle	Highest
23012 (699.2)	23095 (707.5)	23178 (715.8)

NOTE: to operate in compliance with FCC and ISSED regulatory requirements, in frequency allocations closer than 100KHz to the band edges, the channel is disabled. Band 12 is completely included in band 85. so the channels of band 85 were tested to give conformity to the assigned block

NBLoT.  $\pi/2$  - BPSK AND  $\pi/4$  - QPSK MODULATION (BAND 13)

Channel (Frequency. MHz)		
Lowest	Middle	Highest
23182 (777.2)	23230 (782)	23278 (786.8)

NOTE: to operate in compliance with FCC and ISSED regulatory requirements, in frequency allocations closer than 100KHz to the band edges, the channel is disabled.

NBLoT.  $\pi/2$  - BPSK AND  $\pi/4$  - QPSK MODULATION (BAND 66)

Channel (Frequency. MHz)		
Lowest	Middle	Highest
131974 (1710.2)	132322 (1745)	132670 (1779.8)

NBLoT.  $\pi/2$  - BPSK AND  $\pi/4$  - QPSK MODULATION (BAND 85)

Channel (Frequency. MHz)		
Lowest	Middle	Highest
134004 (698.2)	134092 (707)	134180 (715.8)

NOTE: to operate in compliance with FCC and ISSED regulatory requirements, in frequency allocations closer than 100KHz to the band edges, the channel is disabled.

## RF Output Power

### SPECIFICATION

FCC §27.50 (c) (10).

Portable stations (hand-held devices) in the 600 MHz uplink band and the 698-746 MHz band. and fixed and mobile stations in the 600 MHz uplink band are limited to 3 watts ERP.

FCC §27.50 (b) (10).

Portable stations (hand-held devices) transmitting in the 746-757 MHz. 776-788 MHz. and 805-806 MHz bands are limited to 3 watts ERP.

RSS-130 Clause 4.6.

The e.r.p. shall not exceed 30 watts for mobile equipment and outdoor fixed subscriber equipment. The e.r.p. shall not exceed 3 watts for portable equipment and indoor fixed subscriber equipment.

FCC §27.50 (d) (4). RSS-139 Clause 6.5.

Fixed. mobile. and portable (hand-held) stations operating in the 1710-1755 MHz band are limited to 1 watt EIRP (30 dBm). Fixed stations operating in the 1710-1755 MHz band are limited to a maximum antenna height of 10 meters above ground. Mobile and portable stations operating in these bands must employ a means for limiting power to the minimum necessary for successful communications.

### METHOD

The conducted RF output power measurements were made at the RF output terminals of the EUT using the power meter of the Universal Radio Communication tester R&S CMW500. selecting maximum transmission power of the EUT and different modes of modulation.

The maximum equivalent isotropically radiated power (e.i.r.p.) is calculated by adding the declared maximum antenna gain (dBi).

The maximum effective radiated power e.r.p. is calculated from the maximum equivalent isotropically radiated power (e.i.r.p.) by subtracting 2.15 dB:

$$E.R.P. = E.I.R.P. - 2.15 \text{ dB}$$

The EUT was controlled via the Universal Radio Communication tester R&S CMW500 selecting maximum transmission power of the EUT and different modes of modulation.

### TEST SETUP

Conducted average power.



**RESULTS**

**MAXIMUM OUTPUT POWER (CONDUCTED).**

**NB-IoT. BAND 4.**

Ch	Freq. (MHz)	Modulation	BW (kHz)	Num. tone	Offset Tone	Average Power (dBm)	PAPR (dB)
19952	1710.2	π/2 - BPSK	3.75	1	0	23.89	(*)
				1	47	23.76	(*)
			15	1	0	23.11	(*)
				1	11	23.13	(*)
		π/4 - QPSK	3.75	1	0	23.92	(*)
				1	47	23.88	(*)
			15	1	0	23.01	(*)
				1	11	23.08	(*)
				3	0	23.34	4.55
				3	6	23.75	4.13
				6	0	22.70	5.49
				6	6	22.87	5.71
12	0	22.03	6.42				
20175	1732.5	π/2 - BPSK	3.75	1	0	23.43	(*)
				1	47	23.45	(*)
			15	1	0	23.61	(*)
				1	11	23.60	(*)
		π/4 - QPSK	3.75	1	0	23.51	(*)
				1	47	23.49	(*)
			15	1	0	23.35	(*)
				1	11	23.38	(*)
				3	0	22.85	4.22
				3	6	23.34	4.19
				6	0	22.16	5.92
				6	6	22.26	5.83
12	0	21.58	6.36				
20398	1754.8	π/2 - BPSK	3.75	1	0	23.80	(*)
				1	47	23.82	(*)
			15	1	0	23.95	(*)
				1	11	23.92	(*)
		π/4 - QPSK	3.75	1	0	23.84	(*)
				1	47	23.89	(*)
			15	1	0	23.72	(*)
				1	11	23.79	(*)
				3	0	23.17	4.17
				3	6	23.82	4.04
				6	0	22.71	5.60
				6	6	22.85	5.53
12	0	21.93	6.03				

(\*): Preliminary measurements determined that 3, 6 or 12 tones of 15kHz as the worst case. The results in the next tables shows the results for this configuration.

NBLoT. BAND 12.

Ch	Freq. (MHz)	Modulation	BW (kHz)	Num. tone	Offset Tone	Average Power (dBm)	PAPR (dB)
23012	699.2	$\pi/2$ - BPSK	3.75	1	0	23.15	(*)
				1	47	23.15	(*)
			15	1	0	23.12	(*)
				1	11	22.99	(*)
		$\pi/4$ - QPSK	3.75	1	0	23.16	(*)
				1	47	23.22	(*)
			15	1	0	22.89	(*)
				1	11	22.75	(*)
				3	0	23.37	3.53
				3	6	23.92	3.12
				6	0	22.25	4.43
				6	6	22.22	4.59
		12	0	21.48	5.29		
		23095	707.5	$\pi/2$ - BPSK	3.75	1	0
1	47					23.31	(*)
15	1				0	22.97	(*)
	1				11	22.80	(*)
$\pi/4$ - QPSK	3.75			1	0	23.30	(*)
				1	47	23.31	(*)
	15			1	0	22.80	(*)
				1	11	22.67	(*)
				3	0	23.08	3.54
				3	6	23.60	3.24
				6	0	22.19	4.75
				6	6	22.26	4.73
12	0			21.34	5.36		
23178	715.8			$\pi/2$ - BPSK	3.75	1	0
		1	47			23.35	(*)
		15	1		0	22.71	(*)
			1		11	22.49	(*)
		$\pi/4$ - QPSK	3.75	1	0	23.42	(*)
				1	47	23.55	(*)
			15	1	0	22.48	(*)
				1	11	22.40	(*)
				3	0	22.86	3.65
				3	6	23.43	3.44
				6	0	22.00	4.94
				6	6	22.13	4.81
		12	0	21.16	5.60		

(\*): Preliminary measurements determined that 3, 6 or 12 tones of 15kHz as the worst case. The results in the next tables shows the results for this configuration.

NBLoT. BAND 13.

Ch	Freq. (MHz)	Modulation	BW (kHz)	Num. tone	Offset Tone	Average Power (dBm)	PAPR (dB)
23182	777.20	$\pi/2$ - BPSK	3.75	1	0	23.50	(*)
				1	47	23.62	(*)
			15	1	0	22.84	(*)
				1	11	22.91	(*)
		$\pi/4$ - QPSK	3.75	1	0	23.70	(*)
				1	47	23.67	(*)
			15	1	0	22.74	(*)
				1	11	22.70	(*)
				3	0	23.11	4.36
				3	6	23.51	3.97
				6	0	22.29	5.18
				6	6	22.28	5.38
12	0	21.28	6.15				
23230	782	$\pi/2$ - BPSK	3.75	1	0	23.55	(*)
				1	47	23.61	(*)
			15	1	0	23.88	(*)
				1	11	23.84	(*)
		$\pi/4$ - QPSK	3.75	1	0	23.68	(*)
				1	47	23.72	(*)
			15	1	0	23.78	(*)
				1	11	23.75	(*)
				3	0	23.02	4.29
				3	6	23.47	4.05
				6	0	22.29	5.49
				6	6	22.33	5.50
12	0	21.20	6.14				
23278	786.8	$\pi/2$ - BPSK	3.75	1	0	23.58	(*)
				1	47	23.73	(*)
			15	1	0	23.96	(*)
				1	11	23.92	(*)
		$\pi/4$ - QPSK	3.75	1	0	23.77	(*)
				1	47	23.80	(*)
			15	1	0	23.87	(*)
				1	11	23.66	(*)
				3	0	22.98	4.39
				3	6	23.44	4.13
				6	0	22.17	5.58
				6	6	22.44	5.45
12	0	21.23	6.26				

(\*): Preliminary measurements determined that 3, 6 or 12 tones of 15kHz as the worst case. The results in the next tables shows the results for this configuration.

NBLoT. BAND 66.

Ch	Freq. (MHz)	Modulation	BW (kHz)	Num. tone	Offset Tone	Average Power (dBm)	PAPR (dB)
13194	1710.2	$\pi/2$ - BPSK	3.75	1	0	23.84	(*)
				1	47	23.77	(*)
			15	1	0	23.21	(*)
				1	11	23.07	(*)
		$\pi/4$ - QPSK	3.75	1	0	23.89	(*)
				1	47	23.86	(*)
			15	1	0	23.03	(*)
				1	11	23.02	(*)
				3	0	23.31	4.55
				3	6	23.73	4.13
				6	0	22.65	5.60
				6	6	22.71	5.67
12	0	23.93	6.23				
132322	1745	$\pi/2$ - BPSK	3.75	1	0	23.76	(*)
				1	47	23.81	(*)
			15	1	0	23.86	(*)
				1	11	23.82	(*)
		$\pi/4$ - QPSK	3.75	1	0	23.88	(*)
				1	47	23.84	(*)
			15	1	0	23.58	(*)
				1	11	23.45	(*)
				3	0	22.97	4.23
				3	6	23.50	4.17
				6	0	22.40	5.83
				6	6	22.60	5.75
12	0	21.72	6.35				
132670	1779.8	$\pi/2$ - BPSK	3.75	1	0	23.72	(*)
				1	47	23.77	(*)
			15	1	0	23.88	(*)
				1	11	23.83	(*)
		$\pi/4$ - QPSK	3.75	1	0	23.77	(*)
				1	47	23.83	(*)
			15	1	0	23.84	(*)
				1	11	23.66	(*)
				3	0	23.06	4.02
				3	6	23.68	3.86
				6	0	22.55	5.53
				6	6	22.50	5.46
12	0	21.88	6.00				

(\*): Preliminary measurements determined that 3, 6 or 12 tones of 15kHz as the worst case. The results in the next tables shows the results for this configuration.



NBLoT. BAND 85.

Ch	Freq. (MHz)	Modulation	BW (kHz)	Num. tone	Offset Tone	Average Power (dBm)	PAPR (dB)
134004	698.2	$\pi/2$ - BPSK	3.75	1	0	23.23	(*)
				1	47	23.22	(*)
			15	1	0	23.09	(*)
				1	11	23.01	(*)
		$\pi/4$ - QPSK	3.75	1	0	23.18	(*)
				1	47	23.25	(*)
			15	1	0	22.96	(*)
				1	11	22.82	(*)
				3	0	23.39	4.34
				3	6	23.92	4.25
				6	0	22.37	4.52
				6	6	22.44	4.62
		12	0	21.49	5.28		
		134092	707	$\pi/2$ - BPSK	3.75	1	0
1	47					23.29	(*)
15	1				0	22.92	(*)
	1				11	22.83	(*)
$\pi/4$ - QPSK	3.75			1	0	23.28	(*)
				1	47	23.35	(*)
	15			1	0	22.86	(*)
				1	11	22.64	(*)
				3	0	23.14	3.39
				3	6	23.81	3.09
				6	0	22.22	4.77
				6	6	22.27	4.76
12	0			21.26	5.37		
134180	715.8			$\pi/2$ - BPSK	3.75	1	0
		1	47			23.49	(*)
		15	1		0	22.73	(*)
			1		11	22.55	(*)
		$\pi/4$ - QPSK	3.75	1	0	23.49	(*)
				1	47	23.54	(*)
			15	1	0	22.55	(*)
				1	11	22.40	(*)
				3	0	22.90	4.24
				3	6	23.47	4.18
				6	0	22.04	4.99
				6	6	21.91	4.90
		12	0	21.14	5.51		

(\*): Preliminary measurements determined that 3, 6 or 12 tones of 15kHz as the worst case. The results in the next tables shows the results for this configuration.

NBLoT BAND 4.

Channel	Measured maximum average power (dBm) at antenna port	Maximum declared antenna gain (dBi)	Maximum equivalent isotropically radiated power (E.I.R.P.) (dBm)	Maximum effective radiated power E.R.P. (dBm)
Lowest	23.23	2.15	25.38	23.23
Middle	23.18	2.15	25.33	23.18
Highest	23.12	2.15	25.27	23.12
Measurement uncertainty (dB)	<±0.941			

NBLoT BAND 12.

Channel	Measured maximum average power (dBm) at antenna port	Maximum declared antenna gain (dBi)	Maximum equivalent isotropically radiated power (E.I.R.P.) (dBm)	Maximum effective radiated power E.R.P. (dBm)
Lowest	23.25	2.15	25.40	23.25
Middle	23.22	2.15	25.37	23.22
Highest	23.16	2.15	25.31	23.16
Measurement uncertainty (dB)	<±0.941			

NBLoT BAND 13.

Channel	Measured maximum average power (dBm) at antenna port	Maximum declared antenna gain (dBi)	Maximum equivalent isotropically radiated power (E.I.R.P.) (dBm)	Maximum effective radiated power E.R.P. (dBm)
Lowest	22.88	2.15	25.03	22.88
Middle	23.46	2.15	25.61	23.46
Highest	23.00	2.15	25.15	23.00
Measurement uncertainty (dB)	<±0.941			

NBLoT BAND 66.

Channel	Measured maximum average power (dBm) at antenna port	Maximum declared antenna gain (dBi)	Maximum equivalent isotropically radiated power (E.I.R.P.) (dBm)	Maximum effective radiated power E.R.P. (dBm)
Lowest	22.60	2.15	24.75	22.60
Middle	22.47	2.15	24.62	22.47
Highest	22.55	2.15	24.70	22.55
Measurement uncertainty (dB)	<±0.941			

NB IoT BAND 85.

Channel	Measured maximum average power (dBm) at antenna port	Maximum declared antenna gain (dBi)	Maximum equivalent isotropically radiated power (E.I.R.P.) (dBm)	Maximum effective radiated power E.R.P. (dBm)
Lowest	23.31	2.15	25.46	23.31
Middle	23.58	2.15	25.73	23.58
Highest	23.14	2.15	25.29	23.14
Measurement uncertainty (dB)	<±0.941			

Verdict: PASS

PEAK-TO-AVERAGE POWER RATIO (PAPR).

NB-IoT BAND 4.

Preliminary measurements determined that 12 tones of 15kHz as the worst case. The results in the next tables shows the results for this configuration.

Channel Low:

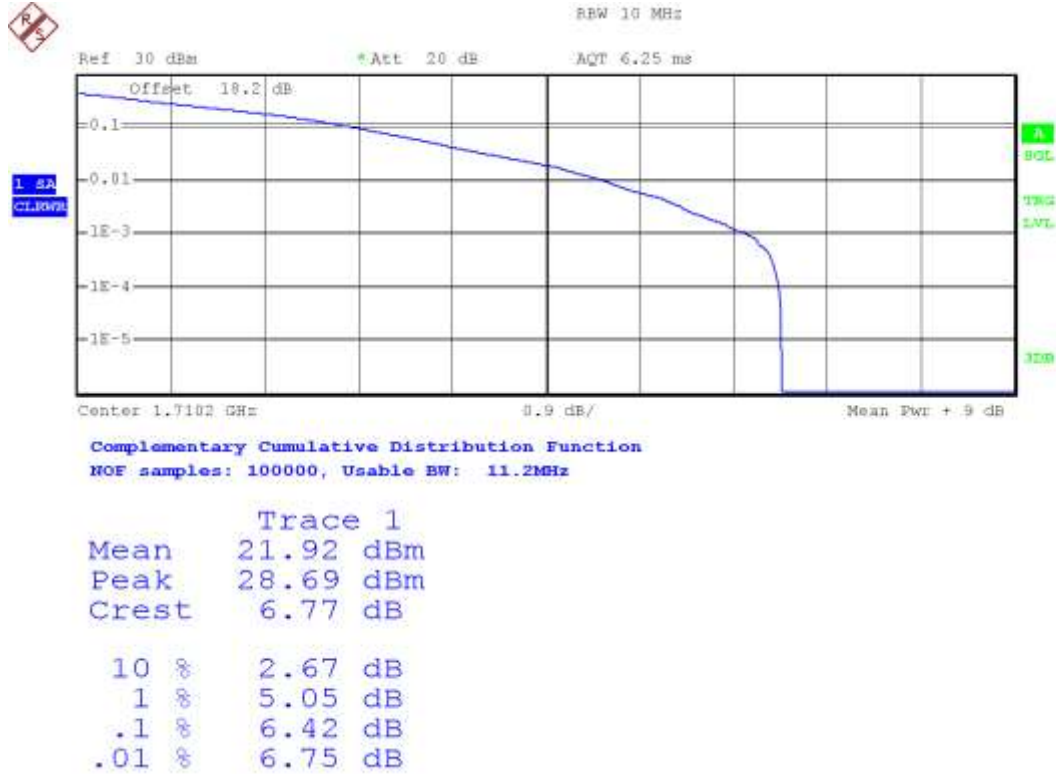

Channel Middle:

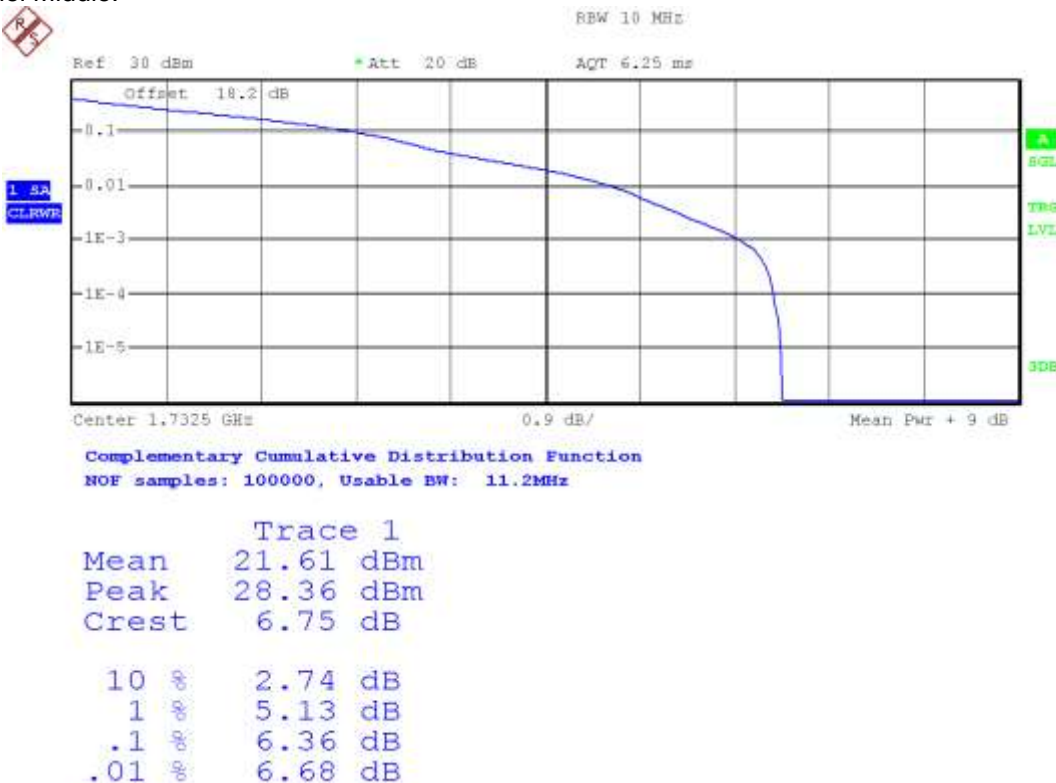

Channel High:

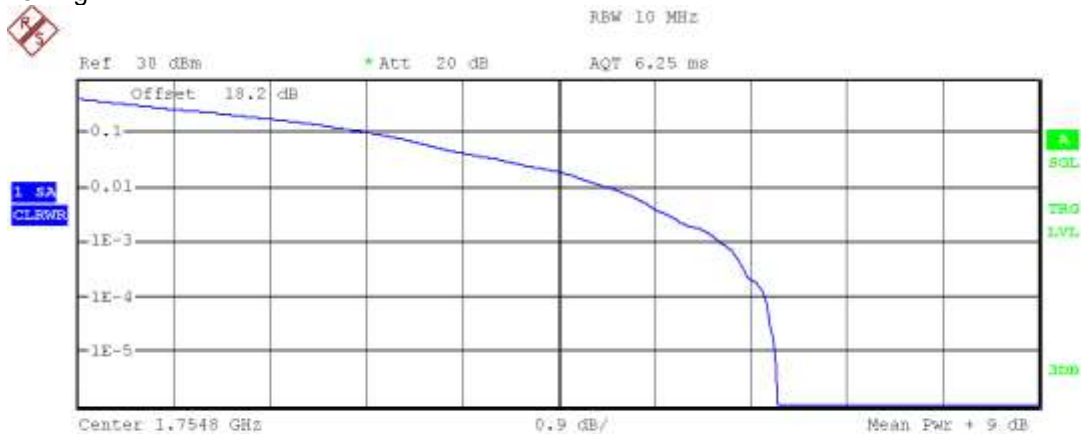

Complementary Cumulative Distribution Function  
 NOF samples: 100000, Usable BW: 11.2MHz

Trace 1	
Mean	21.80 dBm
Peak	28.35 dBm
Crest	6.55 dB
10 %	2.80 dB
1 %	4.99 dB
.1 %	6.03 dB
.01 %	6.45 dB

NB-IoT BAND 12.

Preliminary measurements determined that 12 tones of 15kHz as the worst case. The results in the next tables shows the results for this configuration.

Channel Low:

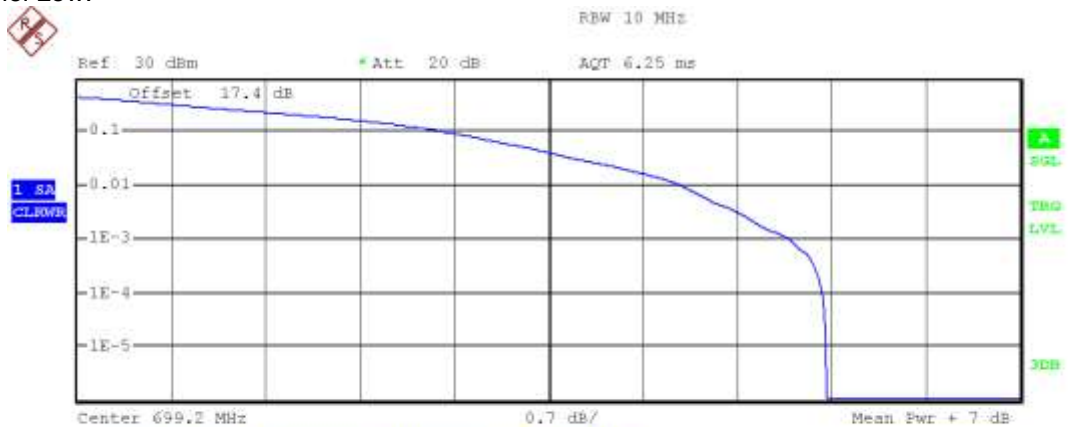

Complementary Cumulative Distribution Function  
 NOF samples: 100000, Usable BW: 11.2MHz

Trace 1	
Mean	21.69 dBm
Peak	27.25 dBm
Crest	5.56 dB
10 %	2.76 dB
1 %	4.49 dB
.1 %	5.29 dB
.01 %	5.54 dB

Channel Middle:

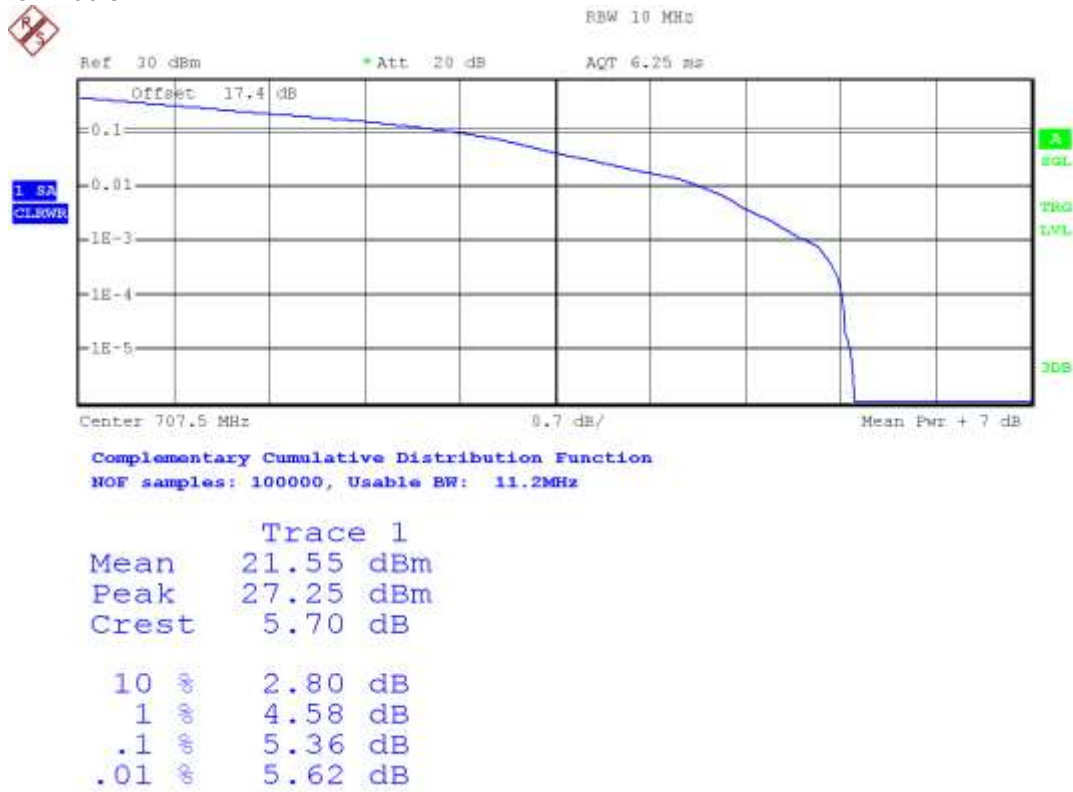

Channel High:

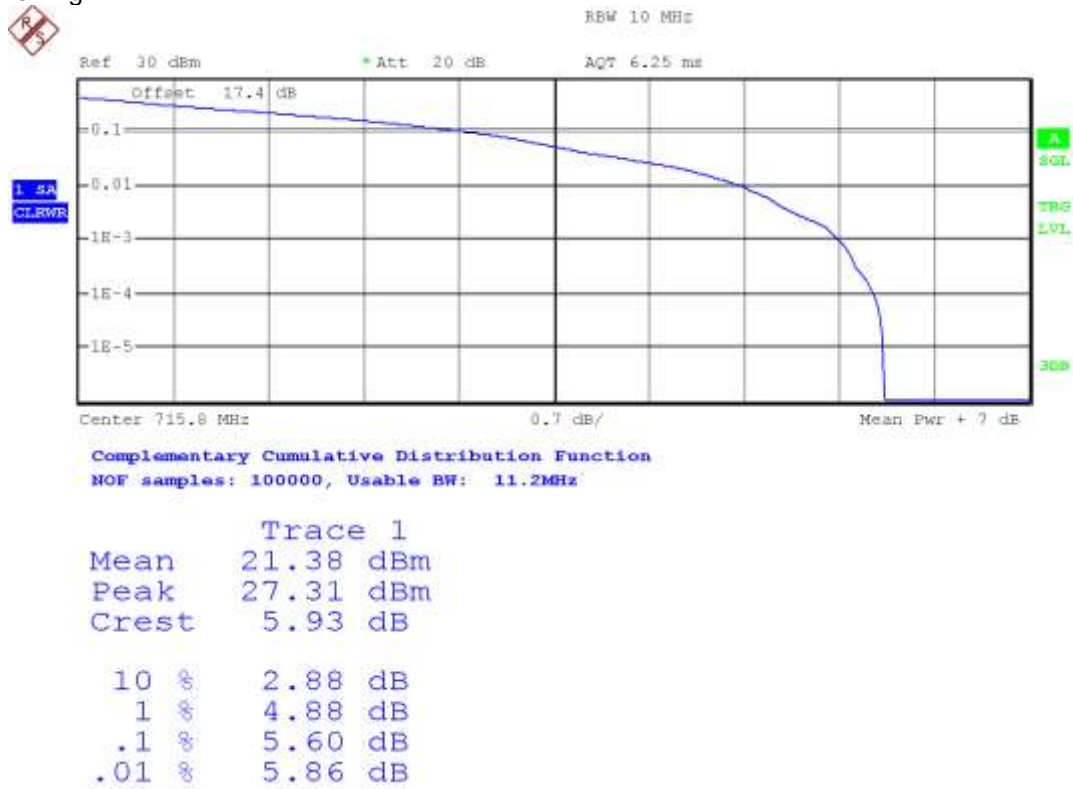

NB-IoT BAND 13.

Preliminary measurements determined that 12 tones of 15kHz as the worst case. The results in the next tables shows the results for this configuration.

Channel Low:

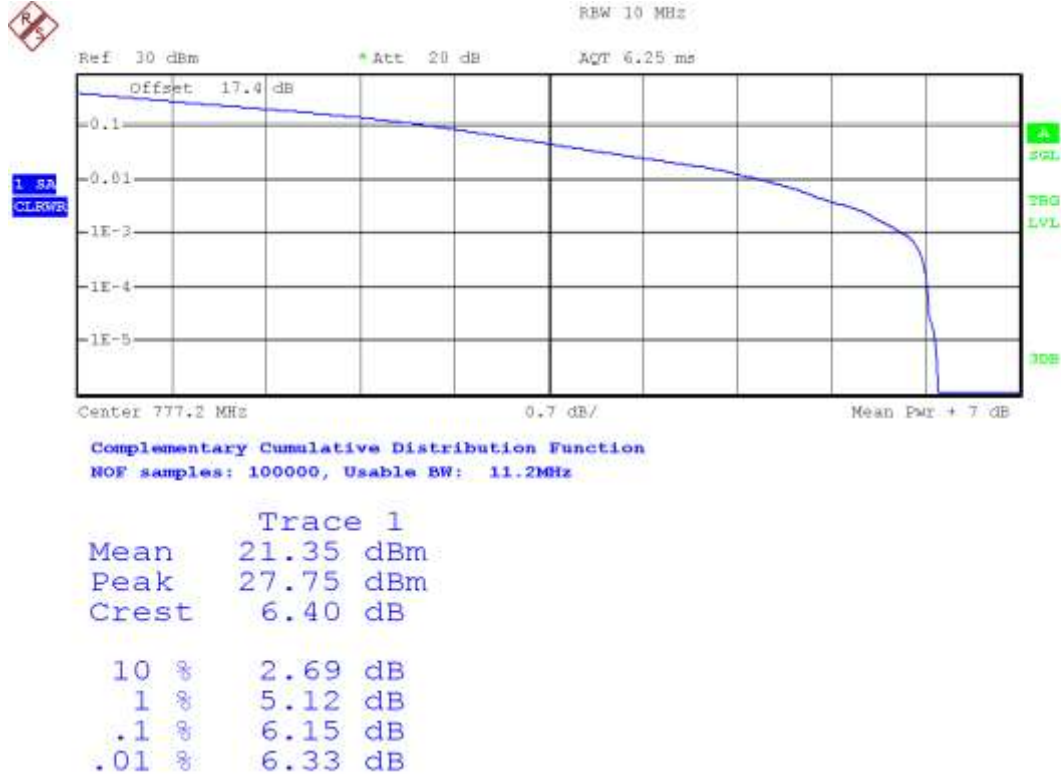

Channel Middle:

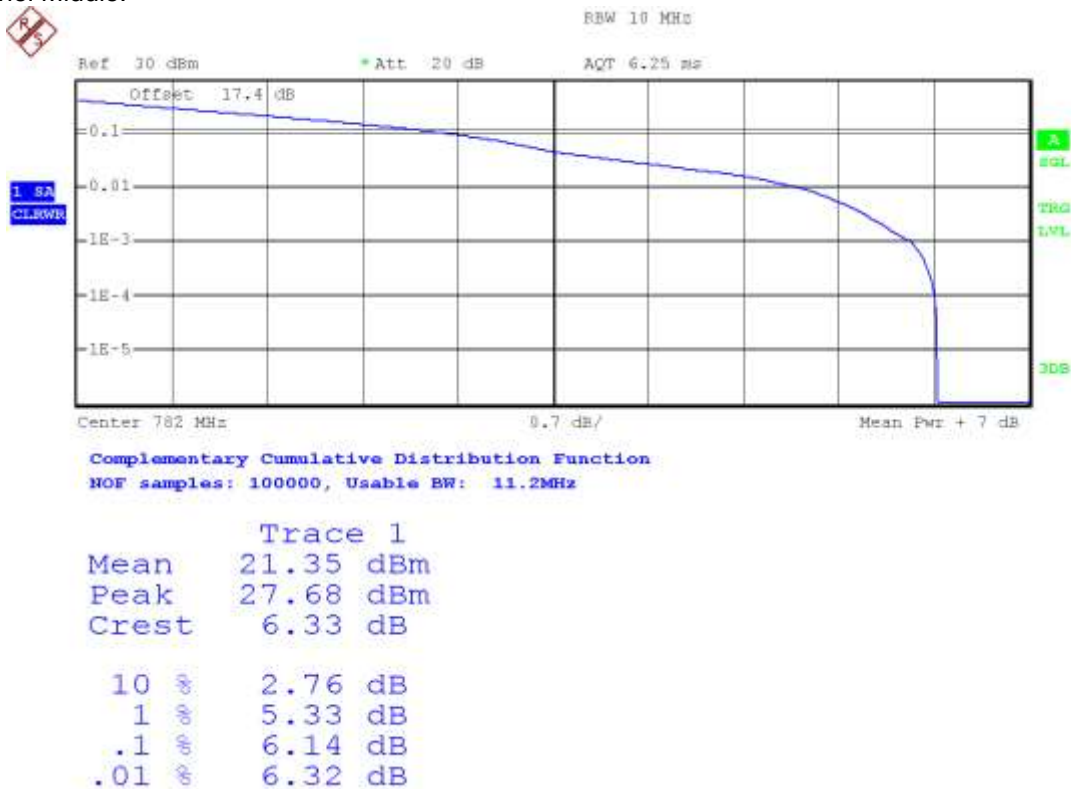

Channel High:

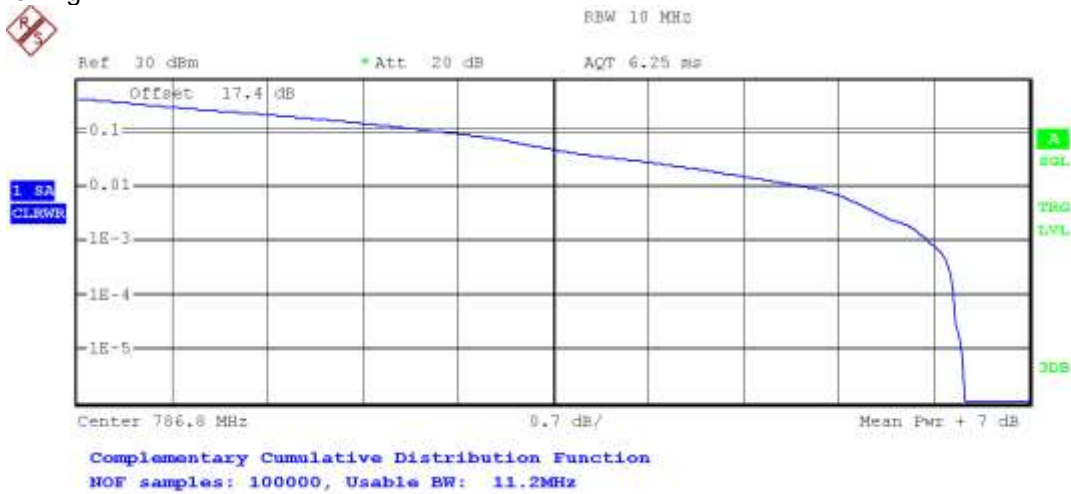

Trace 1	
Mean	21.30 dBm
Peak	27.82 dBm
Crest	6.52 dB
10 %	2.75 dB
1 %	5.36 dB
.1 %	6.26 dB
.01 %	6.45 dB

NB IoT BAND 66.

Preliminary measurements determined that 12 tones of 15kHz as the worst case. The results in the next tables shows the results for this configuration.

Channel Low:



Trace 1	
Mean	21.88 dBm
Peak	28.61 dBm
Crest	6.73 dB
10 %	2.64 dB
1 %	5.15 dB
.1 %	6.23 dB
.01 %	6.67 dB



Channel Middle:

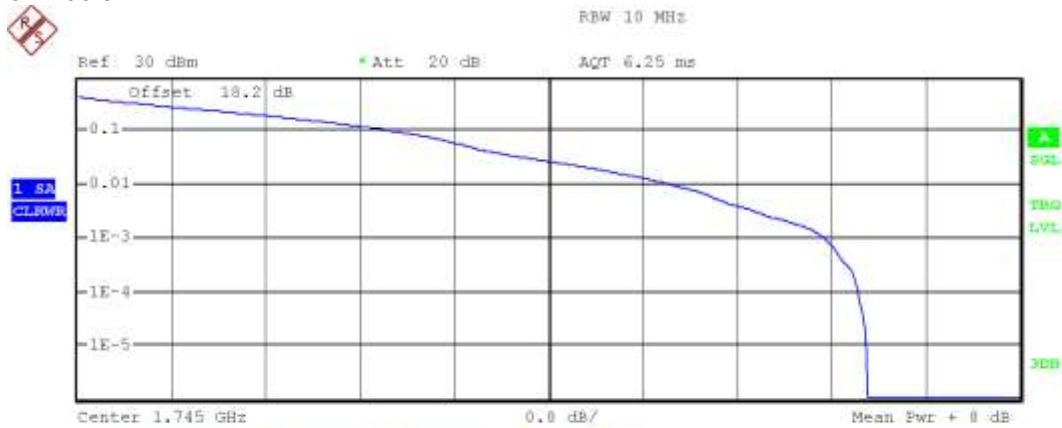

Complementary Cumulative Distribution Function  
 NOF samples: 100000, Usable BW: 11.2MHz

Trace 1	
Mean	21.50 dBm
Peak	28.20 dBm
Crest	6.70 dB
10 %	2.71 dB
1 %	5.06 dB
.1 %	6.35 dB
.01 %	6.63 dB

Channel High:

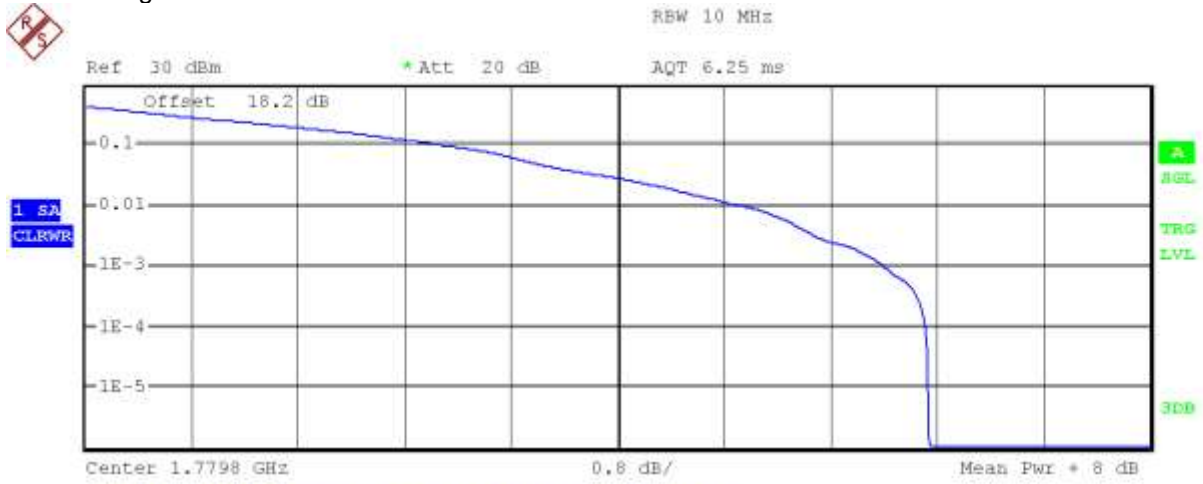

Complementary Cumulative Distribution Function  
 NOF samples: 100000, Usable BW: 11.2MHz

Trace 1	
Mean	21.80 dBm
Peak	28.13 dBm
Crest	6.34 dB
10 %	2.73 dB
1 %	4.95 dB
.1 %	6.00 dB
.01 %	6.32 dB

NB-IoT BAND 85.

Preliminary measurements determined that 12 tones of 15kHz as the worst case. The results in the next tables shows the results for this configuration.

Channel Low:

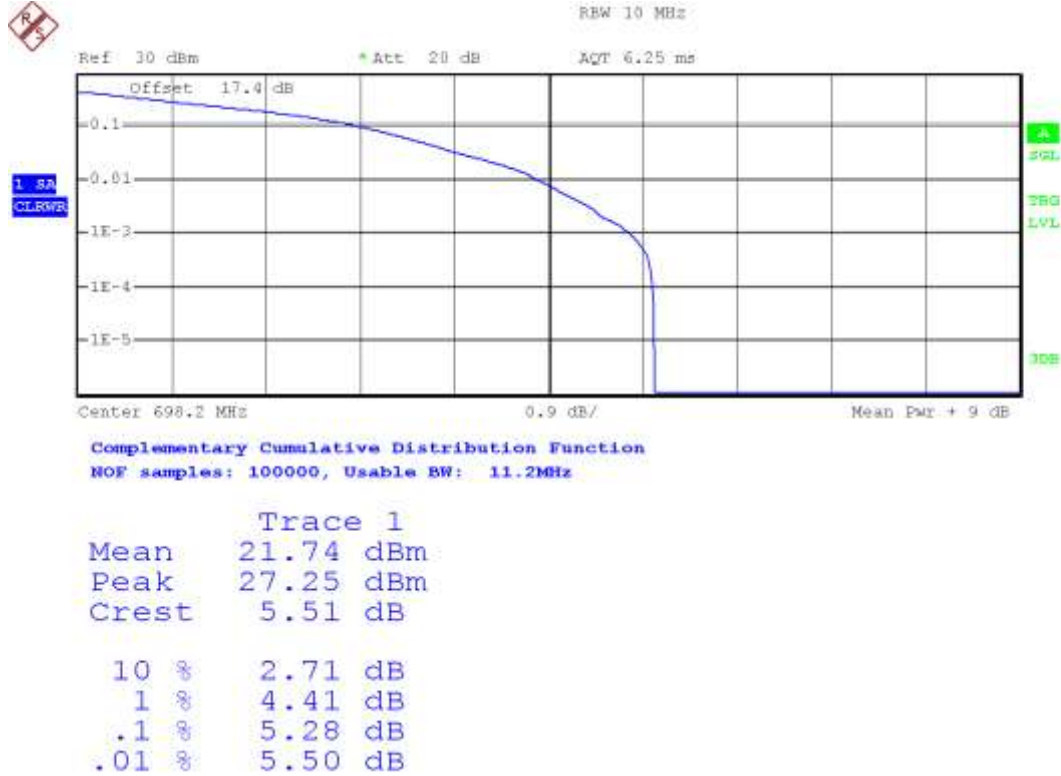

Channel Middle:

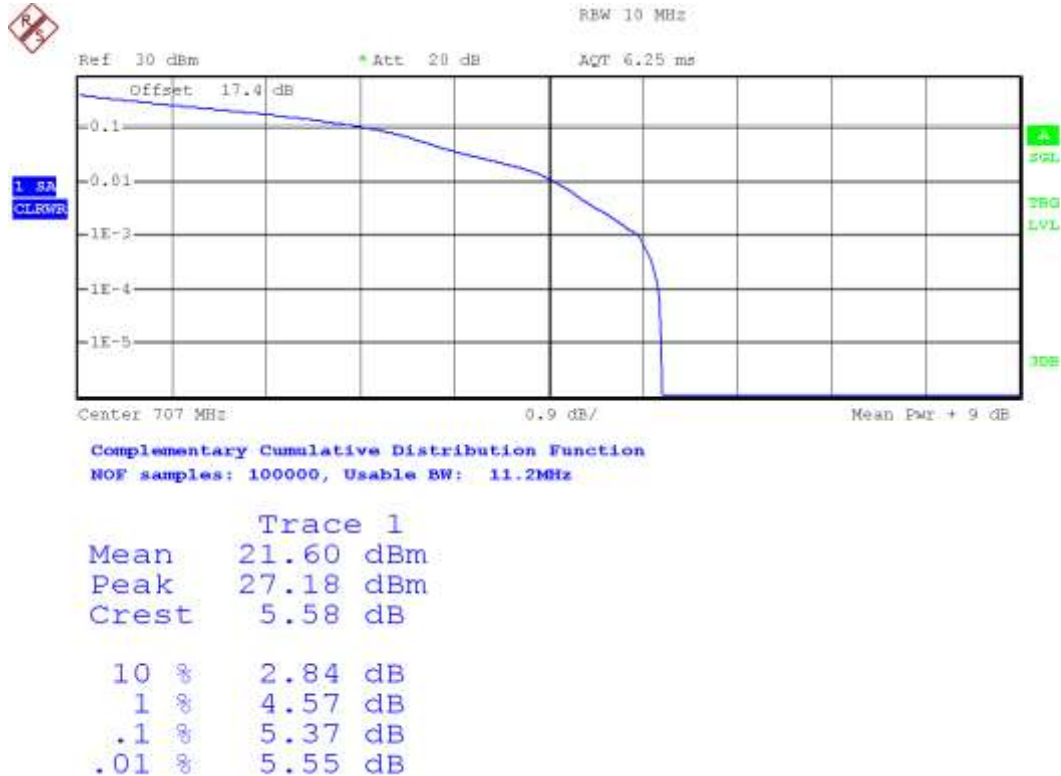

Channel High:

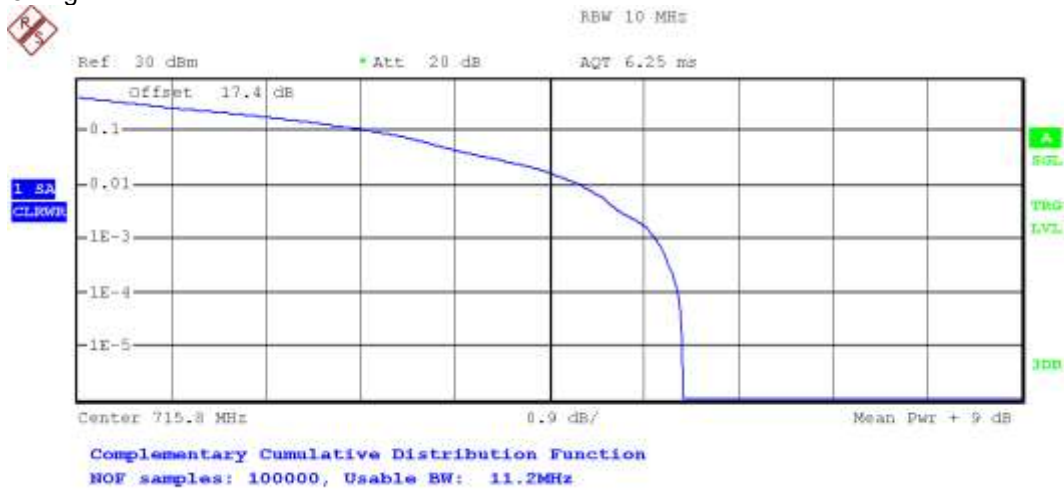

Trace 1	
Mean	21.47 dBm
Peak	27.24 dBm
Crest	5.77 dB
10 %	2.86 dB
1 %	4.80 dB
.1 %	5.51 dB
.01 %	5.73 dB

## Frequency Stability

### SPECIFICATION

FCC §2.1055 and §27.54.

The frequency stability shall be sufficient to ensure that the fundamental emission stays within the authorized frequency block.

RSS-130. Clause 4.5.

The frequency stability shall be sufficient to ensure that the occupied bandwidth remains within each frequency block range when tested at the temperature and supply voltage variations specified in RSS-Gen.

RSS-139 Clause 6.4.

The frequency stability shall be sufficient to ensure that the occupied bandwidth stays within the operating frequency block when tested to the temperature and supply voltage variations specified in RSS-Gen.

### METHOD

The frequency tolerance measurements over temperature variations were made over the temperature range of  $-30^{\circ}\text{C}$  to  $+50^{\circ}\text{C}$ . The EUT was placed inside a climatic chamber and the temperature was raised hourly in  $10^{\circ}\text{C}$  steps from  $-30^{\circ}\text{C}$  up to  $+50^{\circ}\text{C}$ .

The supply voltage was varied between 85% and 115% of nominal voltage.

The EUT was set in "Radio Resource Control (RRC) mode" in the middle channel using the Universal Radio Communication tester R&S CMW500 and the maximum frequency error was measured using the built-in calibrated frequency meter.

The worst case NB-IoT mode for conducted power was used for the test.

In order to check that the frequency stability is sufficient such that the fundamental emissions stay within the authorized bands of operation, a reference point is established at the applicable unwanted emissions limit using a RBW equal to the RBW required by the unwanted emissions specification of the applicable regulatory standard. These reference points measured using the lowest and highest channel of operation are identified as fL and fH respectively. The worst-case frequency offset determined in the above methods is added or subtracted from the values of fL and fH to check that the resulting frequencies remain within the band.

The reference point measurements were made at the RF output terminals of the EUT using an attenuator, power splitter and spectrum analyser. The EUT was controlled via the Universal Radio Communication tester R&S CMW500 selecting maximum transmission power.

## TEST SETUP

Frequency tolerance.

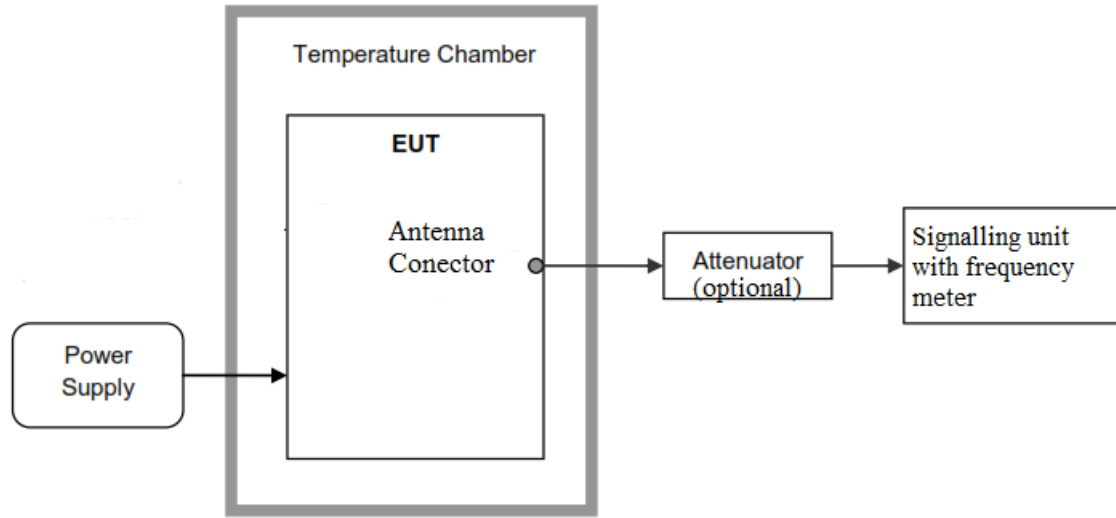

Reference points  $f_L$  and  $f_H$ .

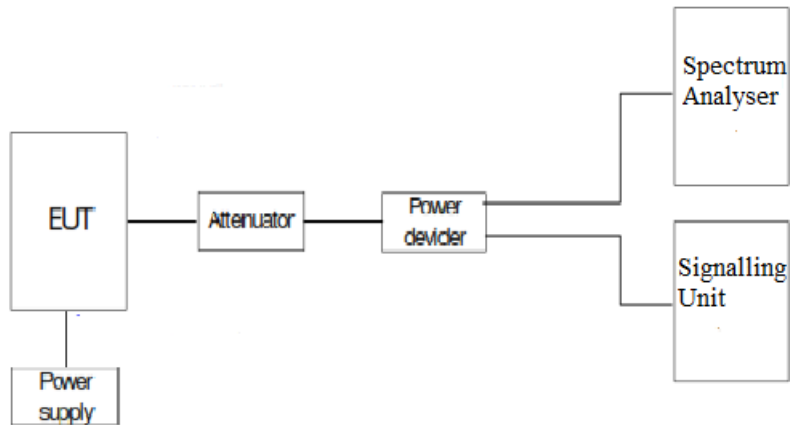

## RESULTS

### Frequency stability over temperature variations.

NBLoT Band 12 -  $\pi/4$  - QPSK modulation. 1 tone 3.75 kHz. Channel: 707.5 MHz.

Temperature (°C)	Frequency Error (Hz)	Frequency Error (ppm)
+50	4.30	0.006077739
+40	-4.19	-0.005922261
+30	3.74	0.005286219
+20	-2.60	-0.003674912
+10	2.23	0.003151943
0	-0.57	-0.000805654
-10	-11.34	-0.016028269
-20	5.01	0.007081272
-30	6.88	0.009724382

Measurement uncertainty (Hz)	< $\pm 87$
------------------------------	------------

NBLoT Band 13 -  $\pi/4$  - QPSK modulation. 1 tone 3.75 kHz. Channel: 782 MHz.

Temperature (°C)	Frequency Error (Hz)	Frequency Error (ppm)
+50	-13.37	-0.017097187
+40	5.92	0.007570332
+30	-5.75	-0.007352941
+20	0.56	0.000716113
+10	5.31	0.006790281
0	0.38	0.000485934
-10	-8.19	-0.010473146
-20	3.28	0.004794373
-30	-4.94	-0.006317136

Measurement uncertainty (Hz)	< $\pm 96$
------------------------------	------------

NBLoT Band 66 -  $\pi/4$  - QPSK modulation. 1 tone 3.75 kHz. Channel: 1745 MHz.

Temperature (°C)	Frequency Error (Hz)	Frequency Error (ppm)
+50	1.03	0.000590258
+40	-2.96	-0.001696275
+30	3.06	0.001753582
+20	-1.15	-0.000659026
+10	-4.57	-0.002618911
0	4.94	0.002830946
-10	1.53	0.000876791
-20	1.07	0.000613181
-30	1.79	0.001025788

Measurement uncertainty (Hz)	<±208
------------------------------	-------

NBLoT Band 85 -  $\pi/4$  - QPSK modulation. 1 tone 3.75 kHz. Channel: 707 MHz.

Temperature (°C)	Frequency Error (Hz)	Frequency Error (ppm)
+50	0.05	0.000070721
+40	-2.45	-0.003465347
+30	8.77	0.012404526
+20	2.76	0.003903819
+10	8.94	0.012644979
0	3.88	0.005487977
-10	-7.24	-0.010240453
-20	1.44	0.002036775
-30	-6.07	-0.008585573

Measurement uncertainty (Hz)	<±87
------------------------------	------

Frequency stability over voltage variations.

NBLoT Band 12

Battery Supply voltage	Voltage (V)	Frequency Error (Hz)	Frequency Error (ppm)
Vmax	4.2	-1.82	-0.002572438
Vmin	3.2	0.63	0.000890459

NBLoT Band 13

Battery Supply voltage	Voltage (V)	Frequency Error (Hz)	Frequency Error (ppm)
Vmax	4.2	0.42	0.000537084
Vmin	3.2	2.66	0.003401535

NBLoT Band 66

Battery Supply voltage	Voltage (V)	Frequency Error (Hz)	Frequency Error (ppm)
Vmax	4.2	-9.13	0.000537084
Vmin	3.2	-3.24	0.003401535

NBLoT Band 85

Battery Supply voltage	Voltage (V)	Frequency Error (Hz)	Frequency Error (ppm)
Vmax	4.2	4.23	0.005983027
Vmin	3.2	-6.93	-0.009801980

Reference points established at the applicable unwanted emissions limit (worst case):

	NBLoT Band 12
$f_L$ (MHz)	699,0291556600
$f_H$ (MHz)	715,9421068800

	NBLoT Band 13
$f_L$ (MHz)	777,0296196300
$f_H$ (MHz)	786,9457059200

	NBLoT Band 66
$f_L$ (MHz)	1710,0663208700



<i>fH</i> (MHz)	1779,9056749400
-----------------	-----------------

	NBLoT Band 85
<i>fL</i> (MHz)	698,0626257600
<i>fH</i> (MHz)	715,9387759400

Reference points *fL* and *fH* with the worst-case frequency offsets added or subtracted:

	NBLoT Band 12
<i>fL</i> (MHz)	699,0292
<i>fH</i> (MHz)	715,9421

	NBLoT Band 13
<i>fL</i> (MHz)	777,0296
<i>fH</i> (MHz)	786,9457

	NBLoT Band 66
<i>fL</i> (MHz)	1710,0663
<i>fH</i> (MHz)	1779,9057

	NBLoT Band 85
<i>fL</i> (MHz)	698,0626
<i>fH</i> (MHz)	715,9388

The reference frequency points stay within the authorized blocks.

Verdict: PASS

## Modulation Characteristics

### SPECIFICATION

FCC §2.1047

RSS-130. Clause 4.2 and RSS-133. Clause 6.2. Equipment certified under this standard shall use digital modulation.

RSS-139 Clause 6.2:

The devices may employ any type of modulation techniques. The type of modulation used must be reported.

RSS-199 Clause 4.1:

Equipment certified under this standard shall employ digital modulation.

### METHOD

For NB-IoT the EUT operates with  $\pi/2$  - BPSK and  $\pi/4$  - QPSK modulation modes in which the information is digitised and coded into a bit stream.

### TEST SETUP

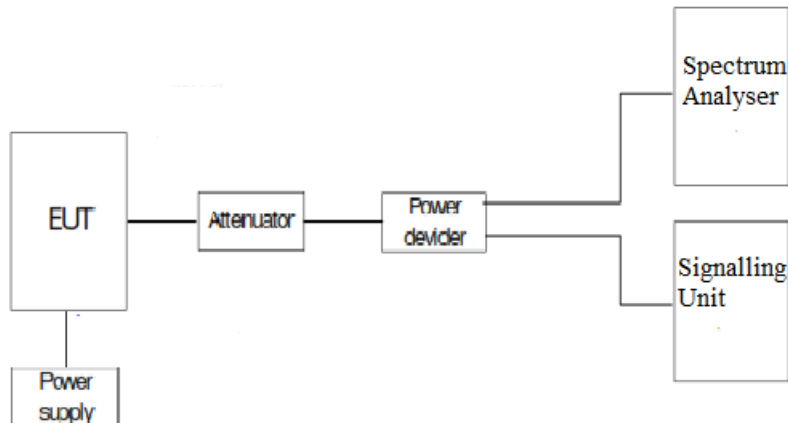

### RESULTS

The following plot shows the modulation schemes in the EUT.

### NBLoT MODULATION (Band 12). $\pi/2$ - BPSK.

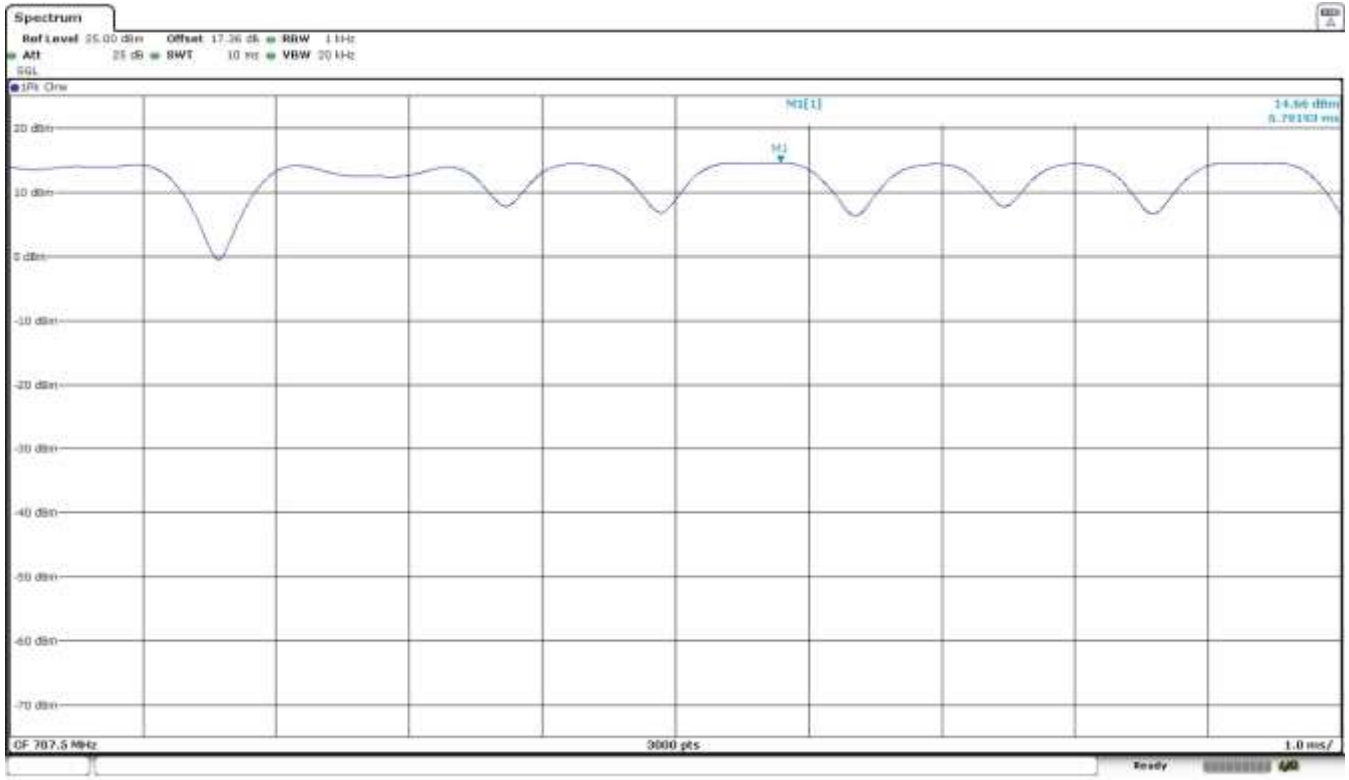

### NBLoT MODULATION (Band 12). $\pi/4$ - QPSK.

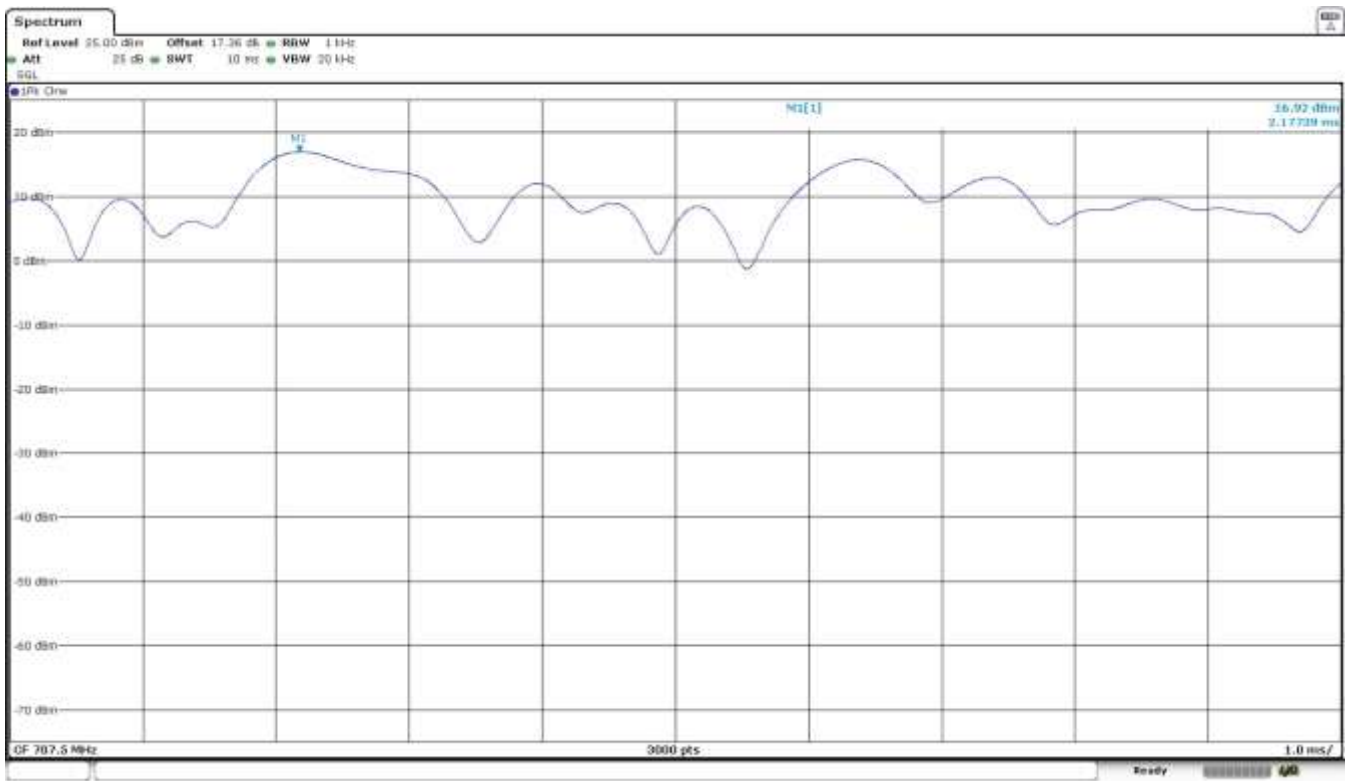

### NBLoT MODULATION (Band 13). $\pi/2$ - BPSK.

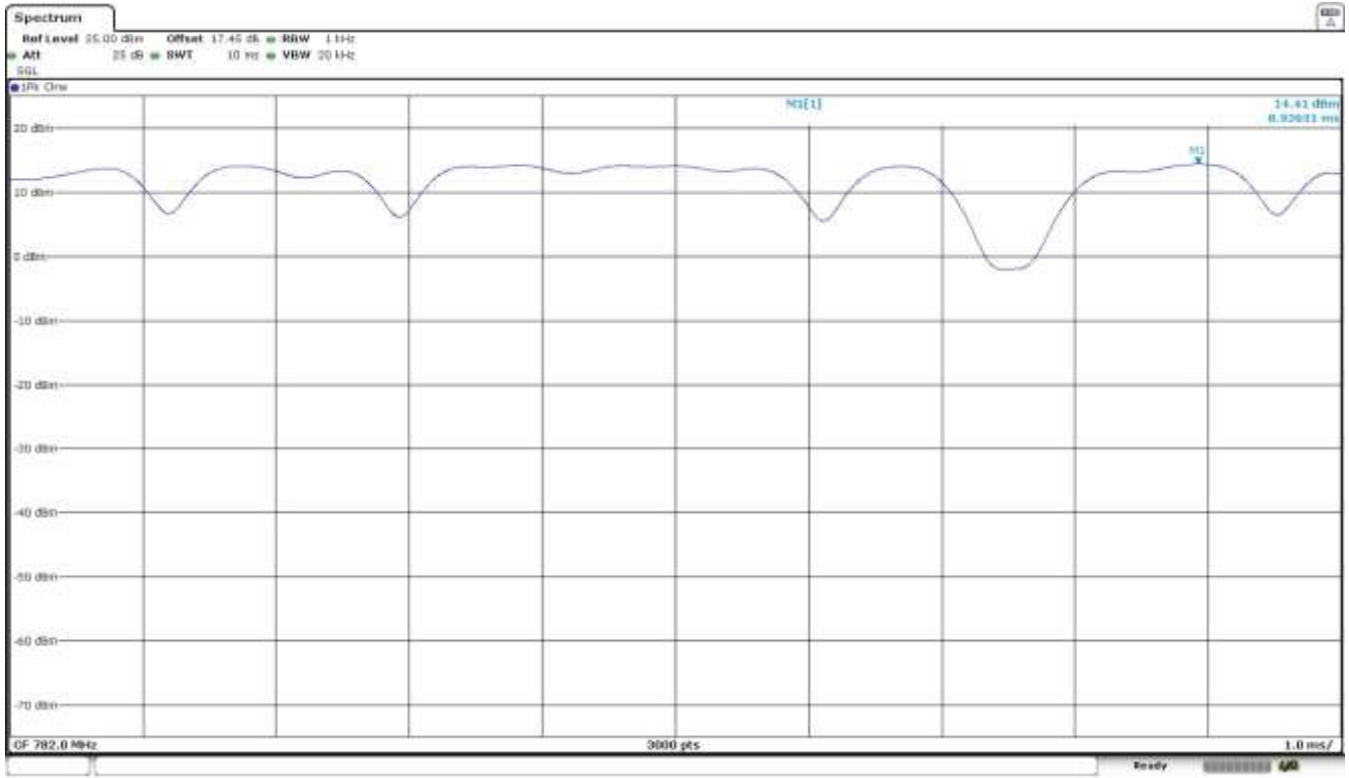

### NBLoT MODULATION (Band 13). $\pi/4$ - QPSK.

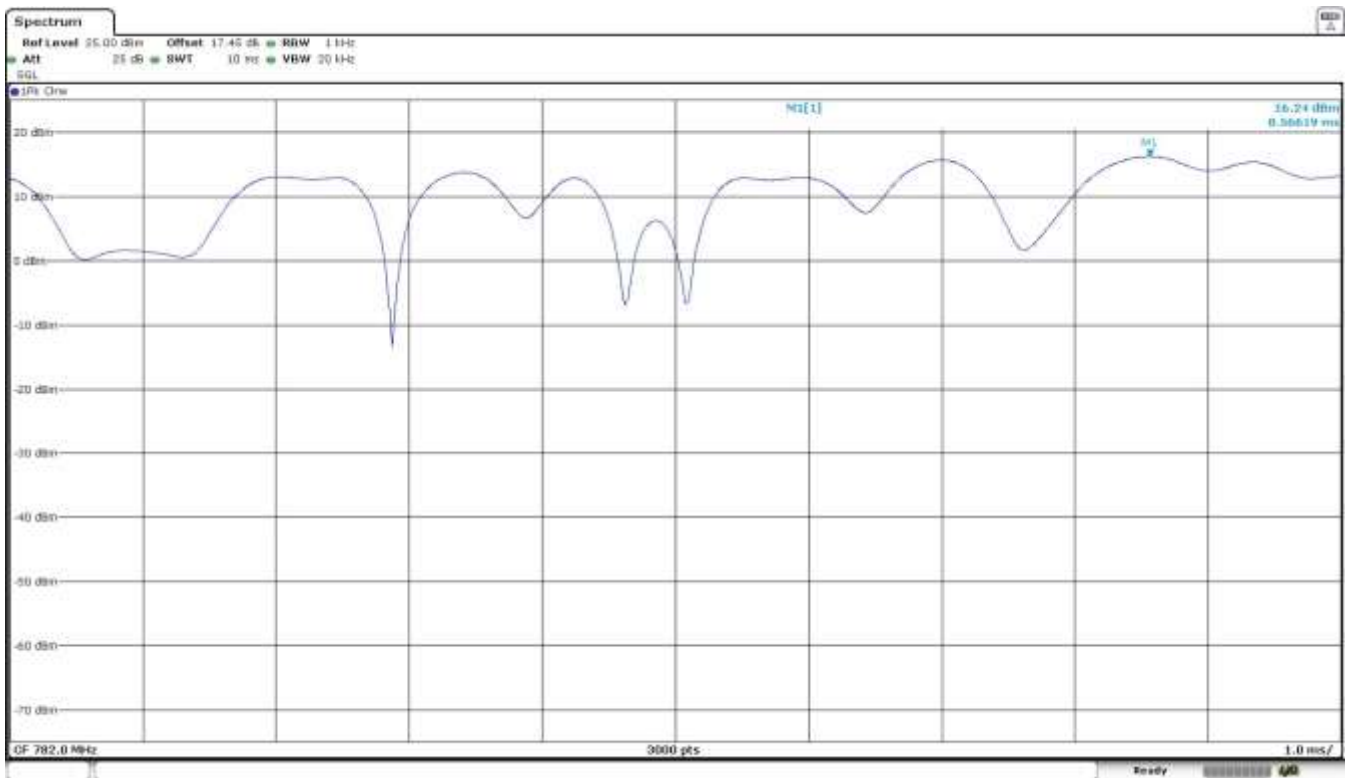

### NBLoT MODULATION (Band 66). $\pi/2$ - BPSK.

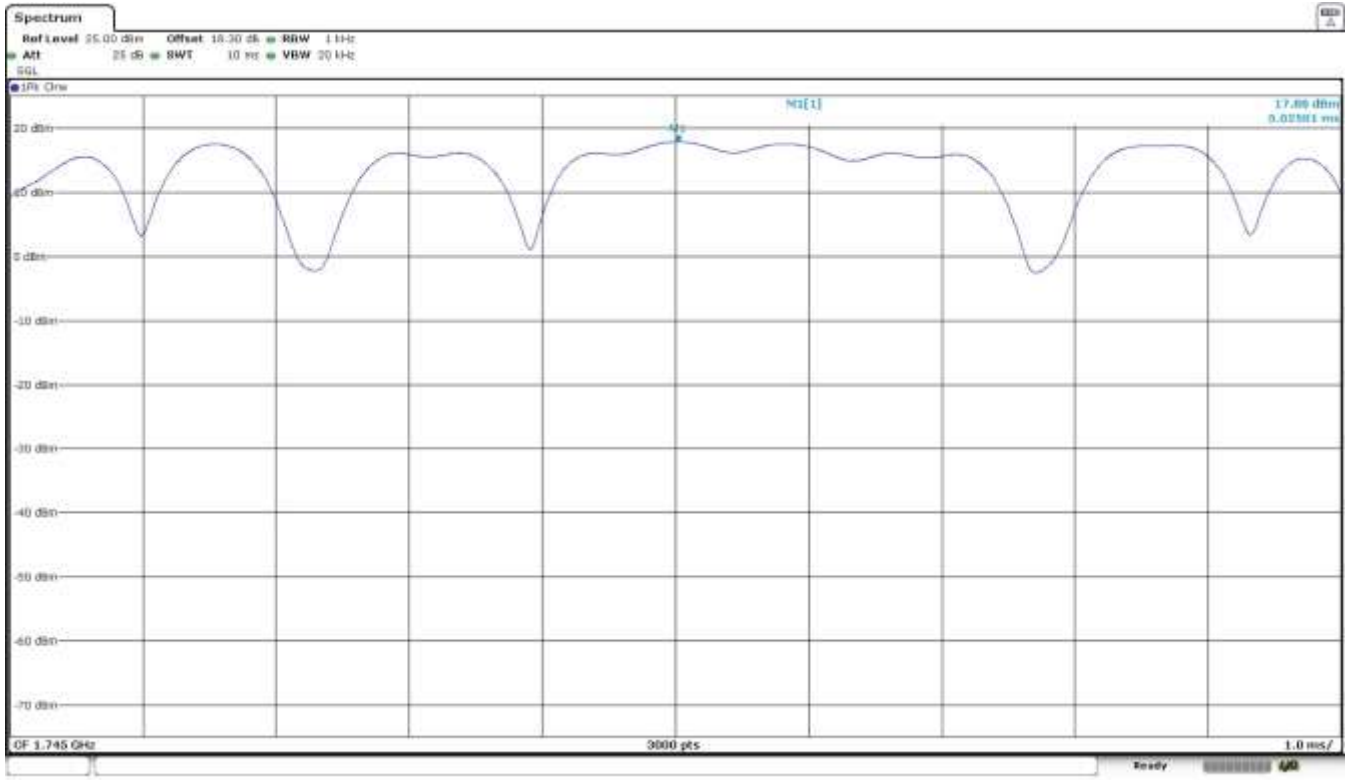

### NBLoT MODULATION (Band 66). $\pi/4$ - QPSK.

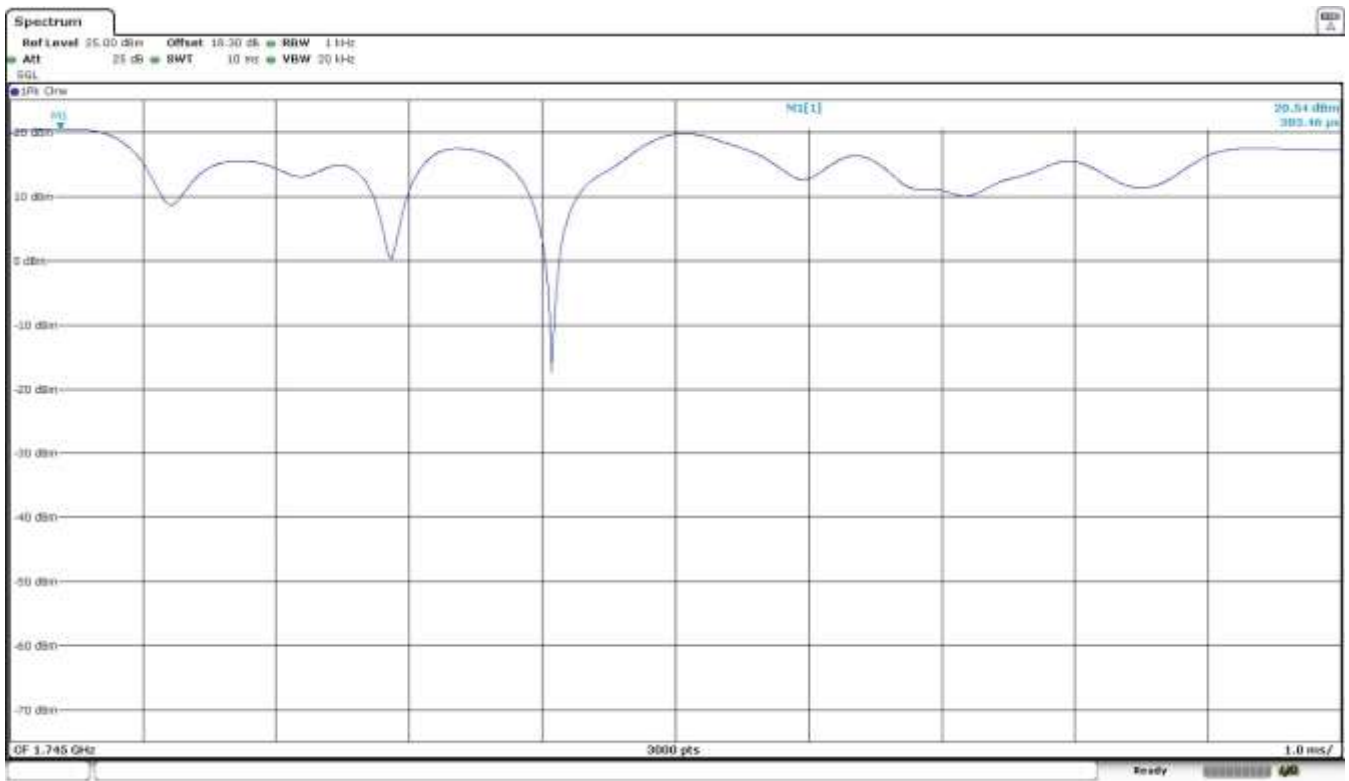

### NBLoT MODULATION (Band 85). $\pi/2$ - BPSK.

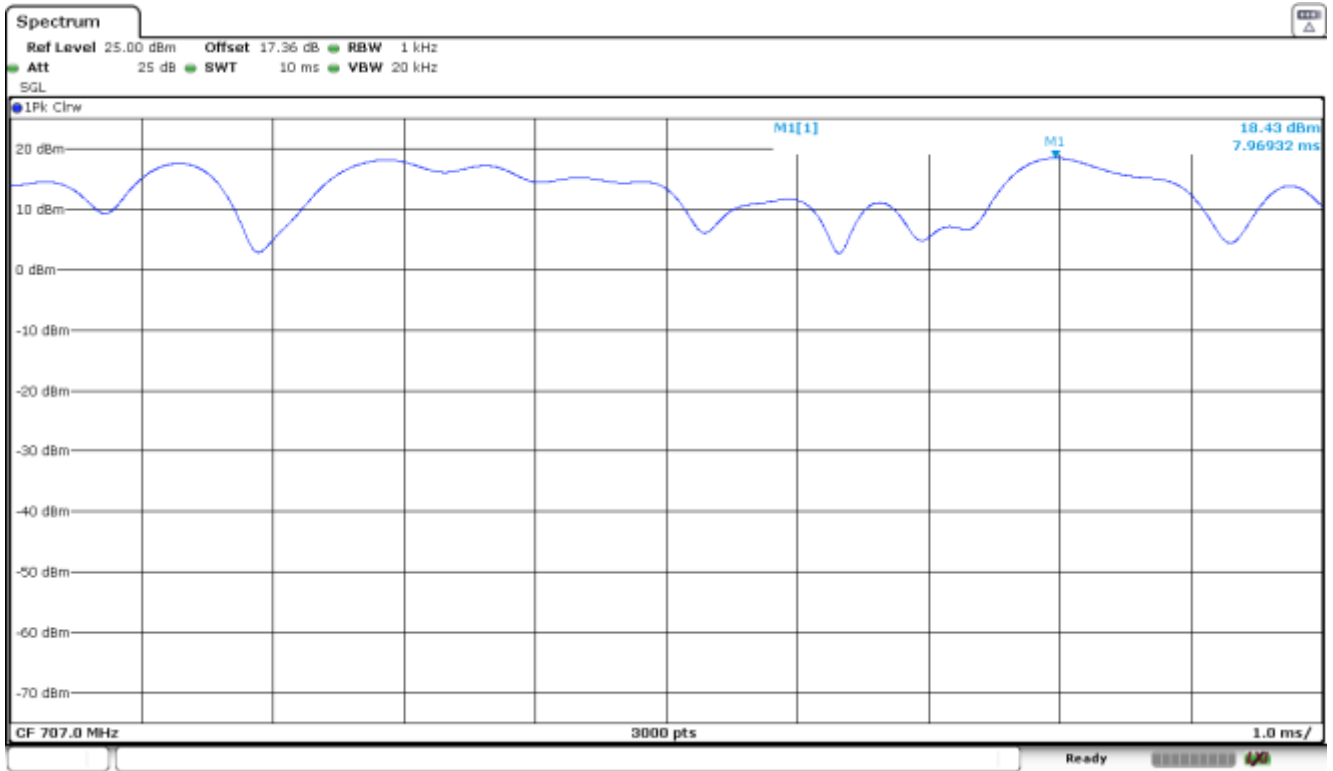

### NBLoT MODULATION (Band 85). $\pi/4$ - QPSK.

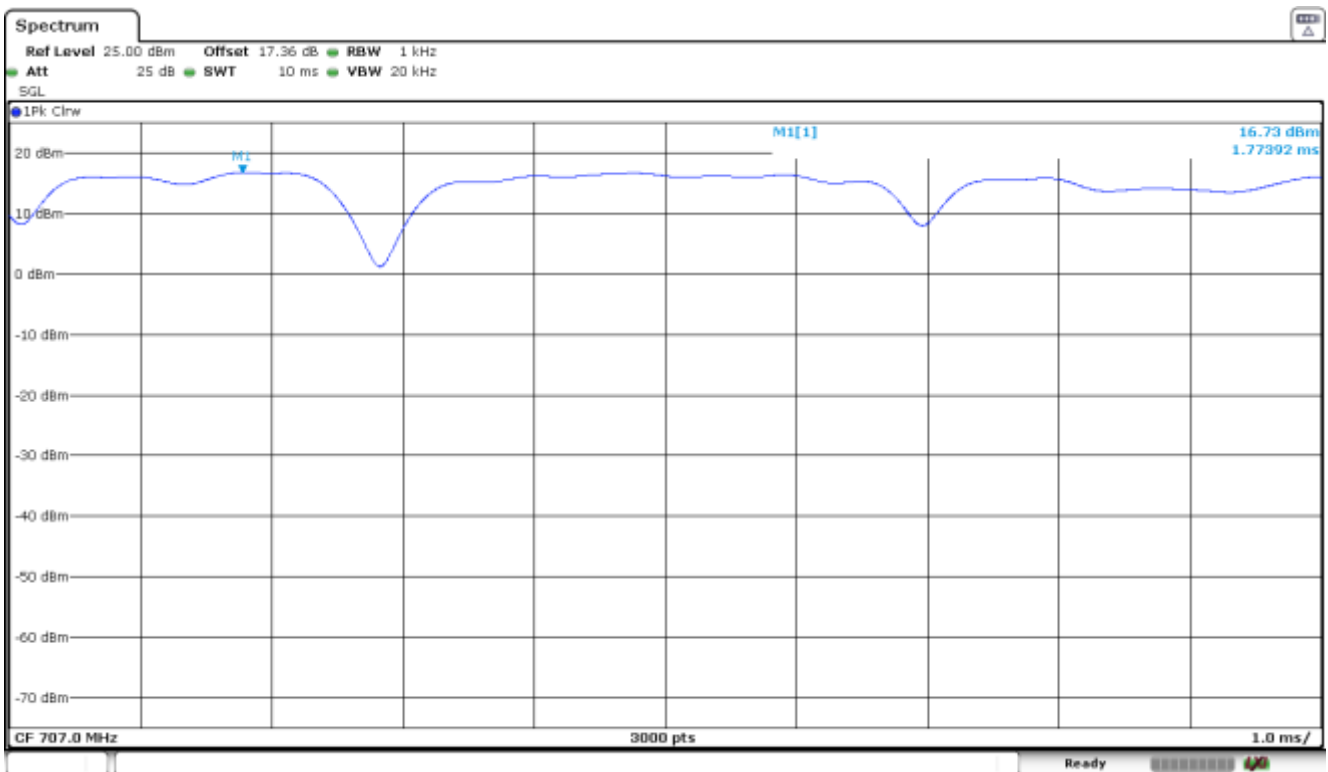

## Occupied Bandwidth

### SPECIFICATION

§2.1049

### METHOD

The occupied bandwidth measurement was performed at the output terminals of the EUT using an attenuator, power splitter and spectrum analyser. The EUT was controlled via the Universal Radio Communication tester R&S CMW500 selecting maximum transmission power of the EUT and different modes of modulation. The 99% occupied bandwidth and the -26 dBc bandwidth were measured directly using the built-in bandwidth measuring option of spectrum analyser.

### TEST SETUP

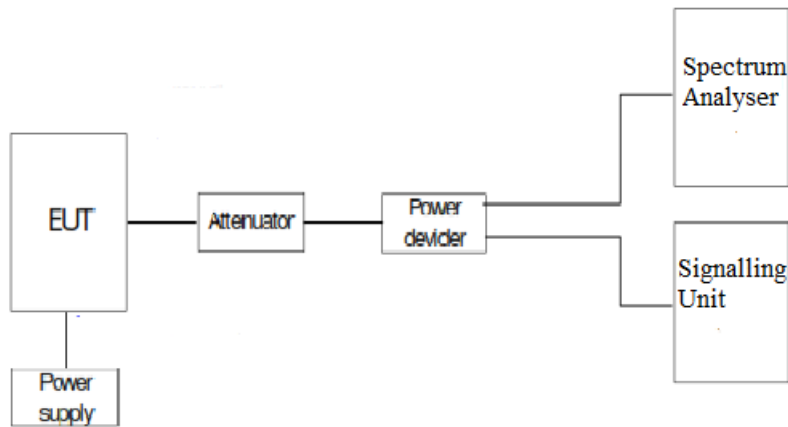

### RESULTS (see next plots)

NBIoT BAND 12.

Tone 3.75 kHz.  $\pi/2$  - BPSK MODULATION

Channel	Lowest	Middle	Highest
99% Occupied bandwidth (kHz)	37.56	37.40	37.13
-26 dBc bandwidth (kHz)	34.80	34.86	34.22
Measurement uncertainty (kHz)	< $\pm$ 0.13		

Tone 3.75 kHz.  $\pi/4$  - QPSK MODULATION

Channel	Lowest	Middle	Highest
99% Occupied bandwidth (kHz)	37.43	37.26	37.60
-26 dBc bandwidth (kHz)	36.93	34.42	34.43
Measurement uncertainty (kHz)	< $\pm$ 0.13		

Tone 15 kHz.  $\pi/2$  - BPSK MODULATION

Channel	Lowest	Middle	Highest
99% Occupied bandwidth (kHz)	74.13	73.33	73.20
-26 dBc bandwidth (kHz)	92.026	92.20	92.09
Measurement uncertainty (kHz)	< $\pm$ 0.27		

12 Tones 15 kHz.  $\pi/4$  - QPSK MODULATION

Channel	Lowest	Middle	Highest
99% Occupied bandwidth (kHz)	189.20	190.53	187.33
-26 dBc bandwidth (kHz)	266.27	255.13	266.53
Measurement uncertainty (kHz)	< $\pm$ 0.12		

NB-IoT BAND 13.

Tone 3.75 kHz.  $\pi/2$  - BPSK MODULATION

Channel	Lowest	Middle	Highest
99% Occupied bandwidth (kHz)	37.23	37.20	37.00
-26 dBc bandwidth (kHz)	34.22	34.77	34.17
Measurement uncertainty (kHz)	< $\pm$ 0.13		

Tone 3.75 kHz.  $\pi/4$  - QPSK MODULATION

Channel	Lowest	Middle	Highest
99% Occupied bandwidth (kHz)	37.01	37.00	37.23
-26 dBc bandwidth (kHz)	34.36	34.37	36.87
Measurement uncertainty (kHz)	< $\pm$ 0.13		

Tone 15 kHz.  $\pi/2$  - BPSK MODULATION

Channel	Lowest	Middle	Highest
99% Occupied bandwidth (kHz)	72.93	73.20	73.00
-26 dBc bandwidth (kHz)	89.40	92.46	92.26
Measurement uncertainty (kHz)	< $\pm$ 0.27		



12 Tones 15 kHz.  $\pi/4$  - QPSK MODULATION

Channel	Lowest	Middle	Highest
99% Occupied bandwidth (kHz)	191.73	191.46	191.46
-26 dBc bandwidth (kHz)	265.73	266.20	265.07
Measurement uncertainty (kHz)	< $\pm$ 0.65		

NBLoT BAND 66.

Tone 3.75 kHz.  $\pi/2$  - BPSK MODULATION

Channel	Lowest	Middle	Highest
99% Occupied bandwidth (kHz)	38.66	38.80	38.70
-26 dBc bandwidth (kHz)	34.80	34.91	34.94
Measurement uncertainty (kHz)	< $\pm$ 0.13		

Tone 3.75 kHz.  $\pi/4$  - QPSK MODULATION

Channel	Lowest	Middle	Highest
99% Occupied bandwidth (kHz)	38.70	38.86	38.56
-26 dBc bandwidth (kHz)	37.60	37.55	37.61
Measurement uncertainty (kHz)	< $\pm$ 0.13		

Tone 15 kHz.  $\pi/2$  - BPSK MODULATION

Channel	Lowest	Middle	Highest
99% Occupied bandwidth (kHz)	73.60	73.40	73.40
-26 dBc bandwidth (kHz)	92.34	92.19	92.58
Measurement uncertainty (kHz)	< $\pm$ 0.27		

12 Tones 15 kHz.  $\pi/4$  - QPSK MODULATION

Channel	Lowest	Middle	Highest
99% Occupied bandwidth (kHz)	192.26	192.13	192.53
-26 dBc bandwidth (kHz)	277.20	277.52	276.58
Measurement uncertainty (kHz)	< $\pm$ 0.65		

NBLoT BAND 85.

Tone 3.75 kHz.  $\pi/2$  - BPSK MODULATION

Channel	Lowest	Middle	Highest
99% Occupied bandwidth (kHz)	38.20	38.40	38.20
-26 dBc bandwidth (kHz)	34.20	34.80	34.16
Measurement uncertainty (kHz)	< $\pm$ 0.13		

Tone 3.75 kHz.  $\pi/4$  - QPSK MODULATION

Channel	Lowest	Middle	Highest
99% Occupied bandwidth (kHz)	38.80	38.66	38.76
-26 dBc bandwidth (kHz)	40.20	40.24	40.19
Measurement uncertainty (kHz)	< $\pm$ 0.13		

Tone 15 kHz.  $\pi/2$  - BPSK MODULATION

Channel	Lowest	Middle	Highest
99% Occupied bandwidth (kHz)	73.93	73.80	73.73
-26 dBc bandwidth (kHz)	96.03	95.84	95.35
Measurement uncertainty (kHz)	< $\pm$ 0.27		

12 Tones 15 kHz.  $\pi/4$  - QPSK MODULATION

Channel	Lowest	Middle	Highest
99% Occupied bandwidth (kHz)	190.93	190.93	190.26
-26 dBc bandwidth (kHz)	267.84	278.01	255.17
Measurement uncertainty (kHz)	< $\pm$ 0.65		

NB-IoT BAND 12.

Tone 3.75 kHz.  $\pi/2$  - BPSK MODULATION

Lowest Channel

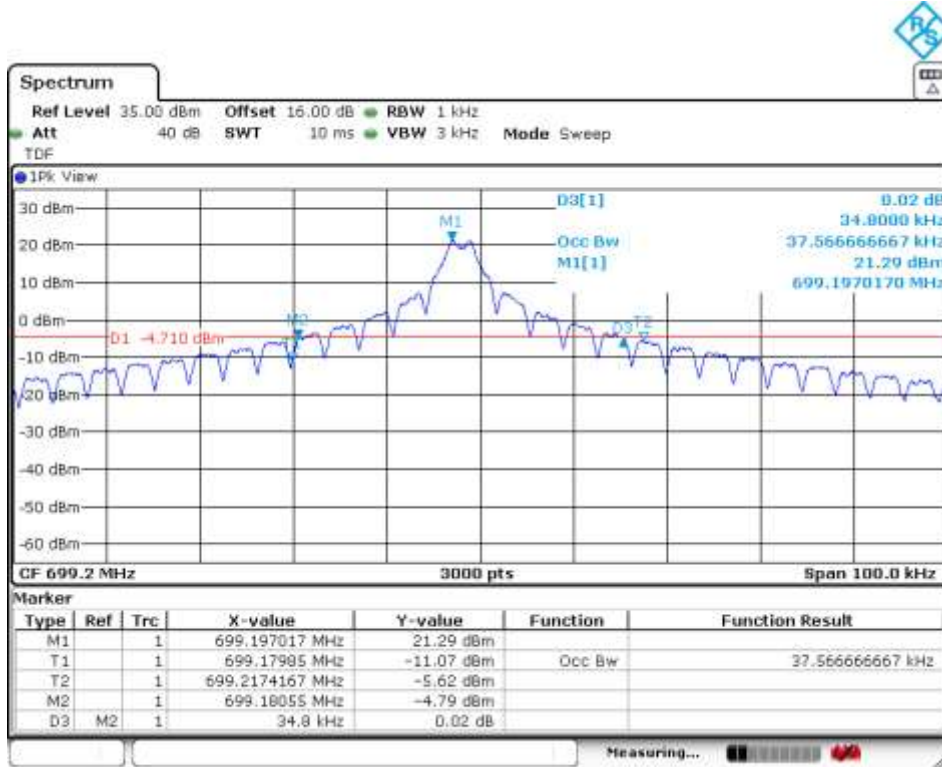

Middle Channel

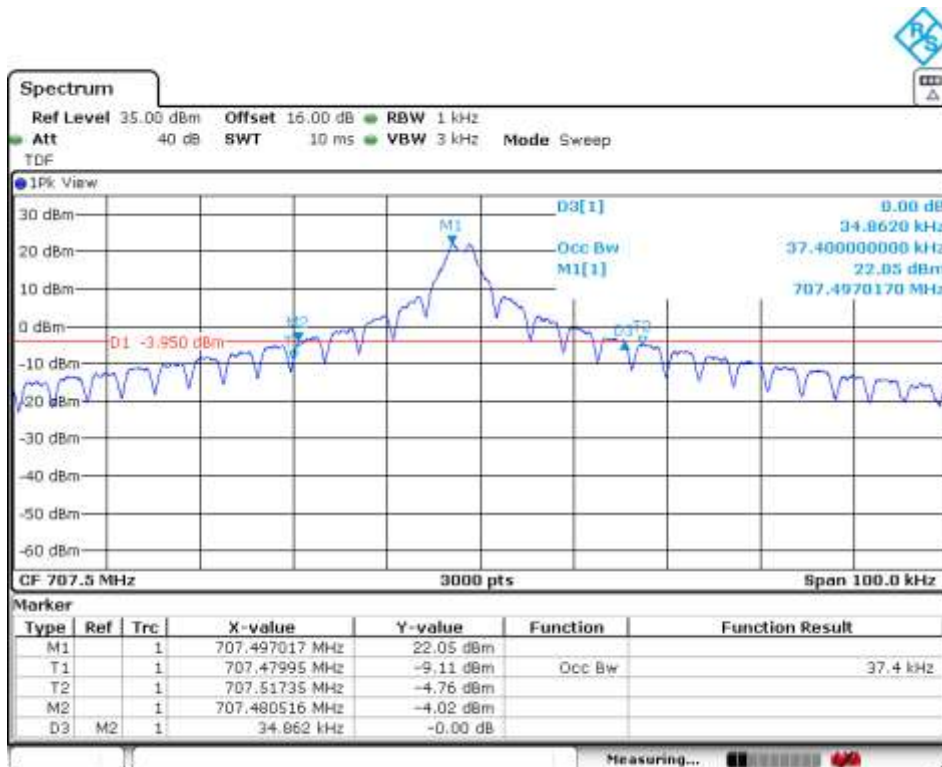

### Highest Channel

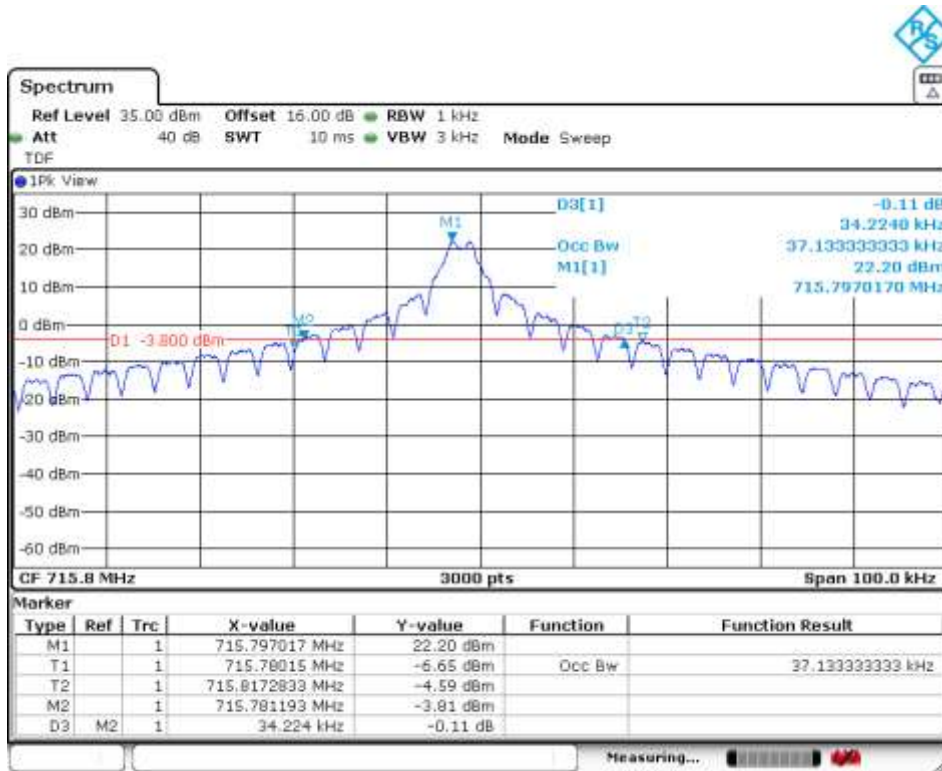

### Tone 3.75 kHz. $\pi/4$ - QPSK MODULATION

### Lowest Channel

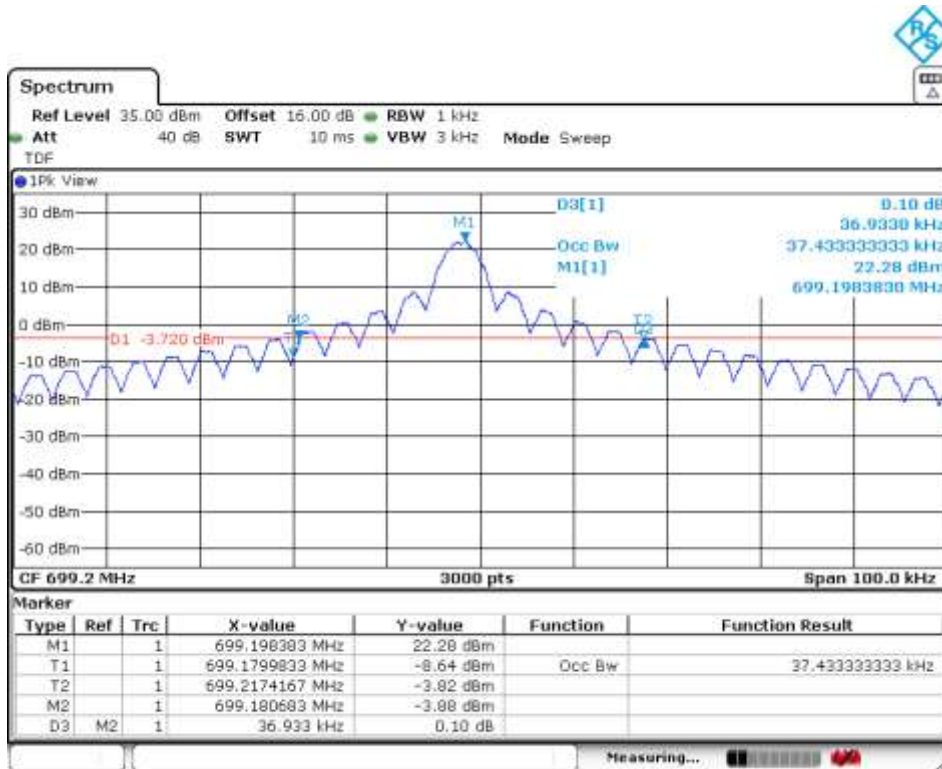

Middle Channel

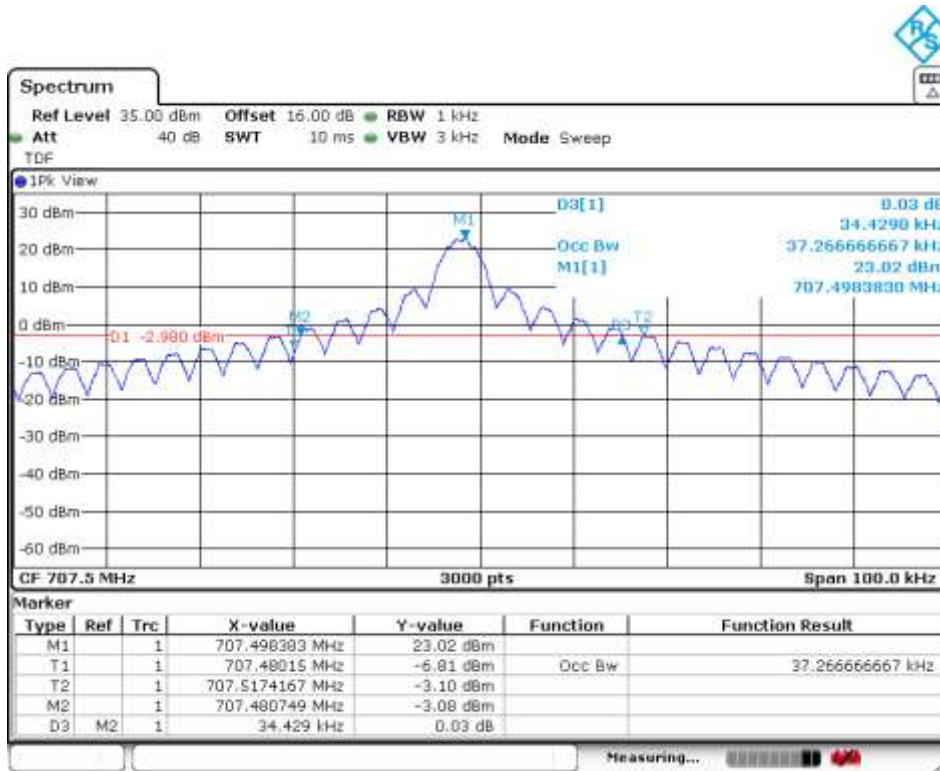

Highest Channel

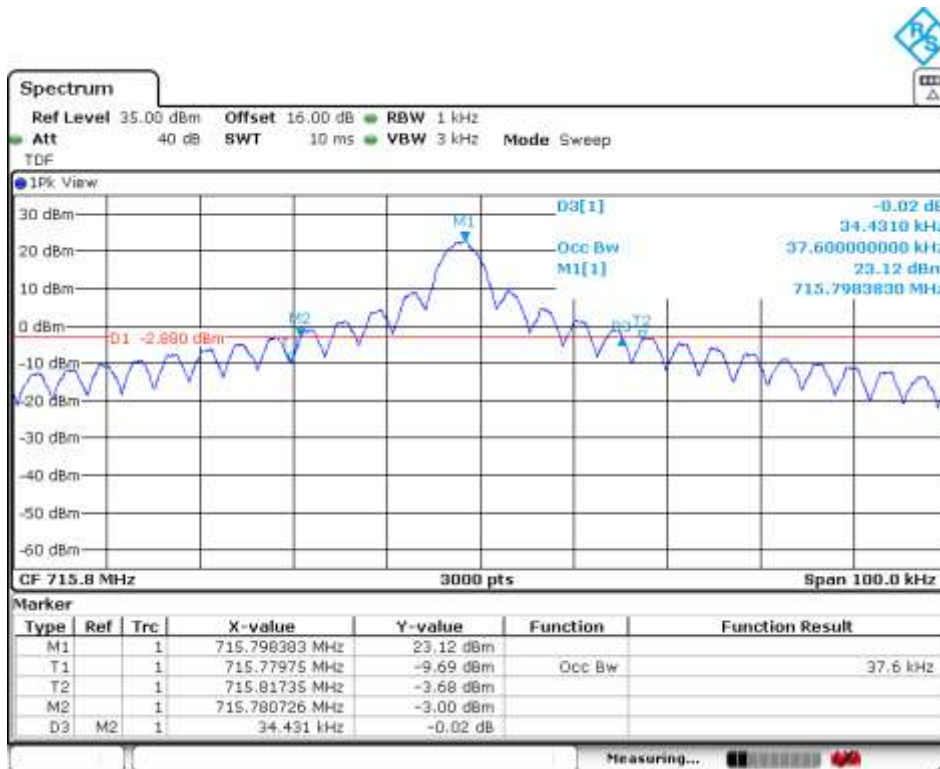

Tone 15 kHz.  $\pi/2$  - BPSK MODULATION  
 Lowest Channel

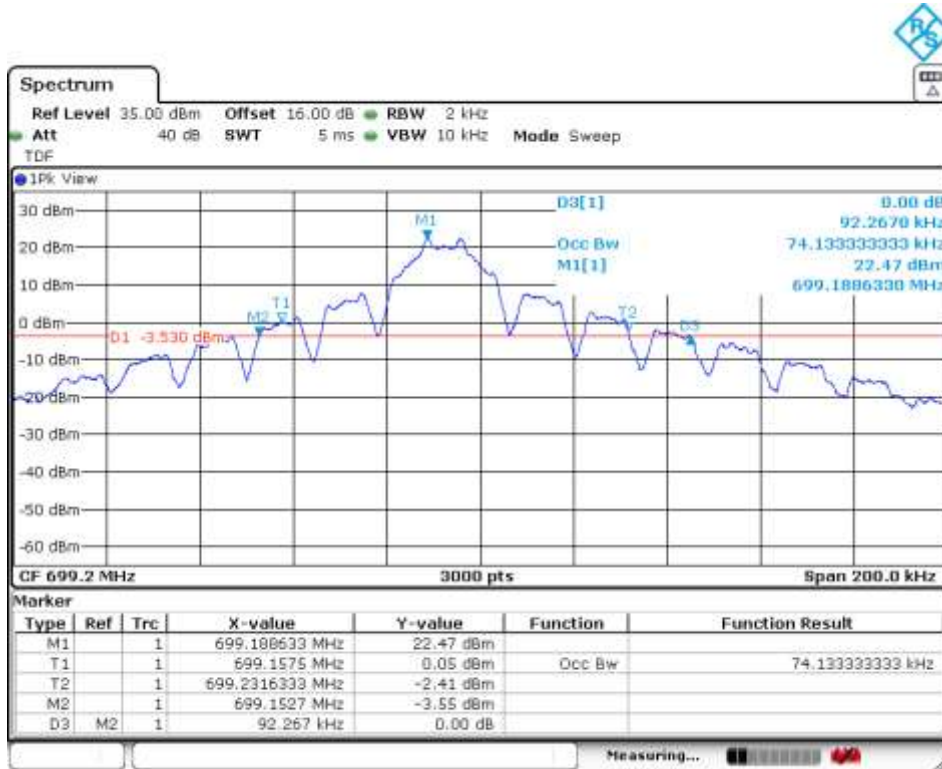

Middle Channel

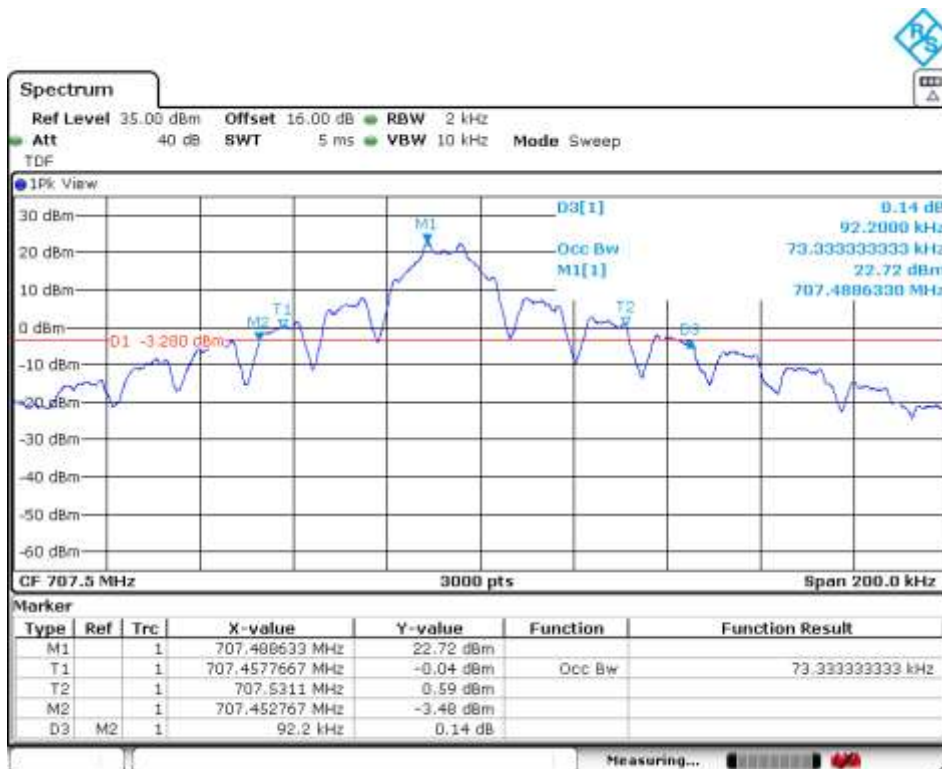

Highest Channel



12 Tones 15 kHz.  $\pi/4$  - QPSK MODULATION

Lowest Channel



Middle Channel

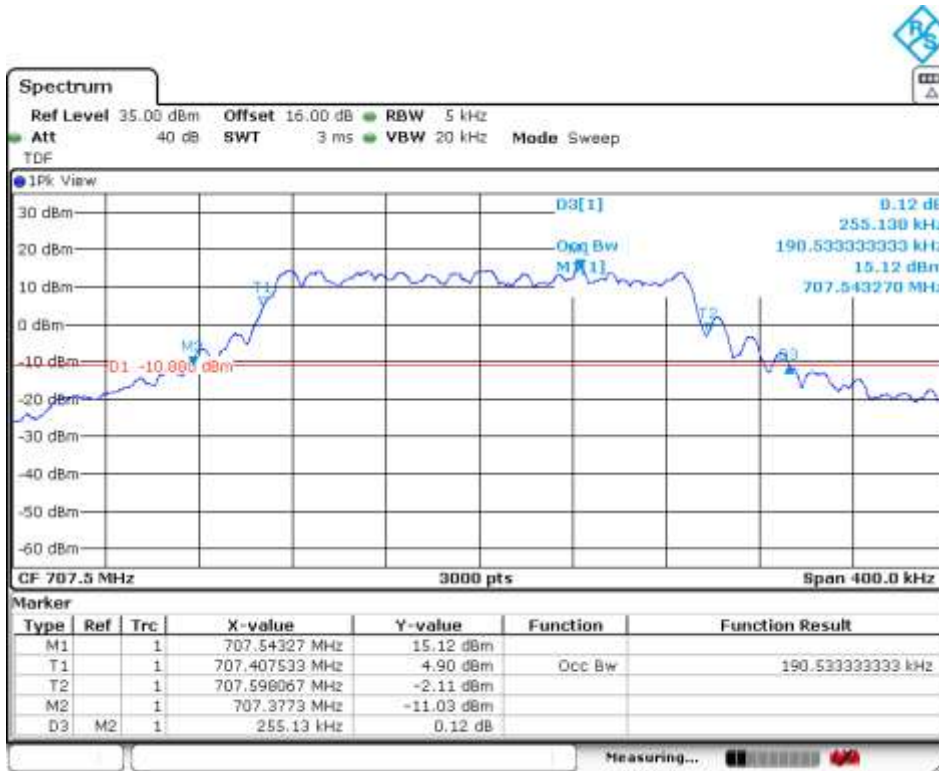

Highest Channel





NB IoT BAND 13.

Tone 3.75 kHz.  $\pi/2$  - BPSK MODULATION

Lowest Channel

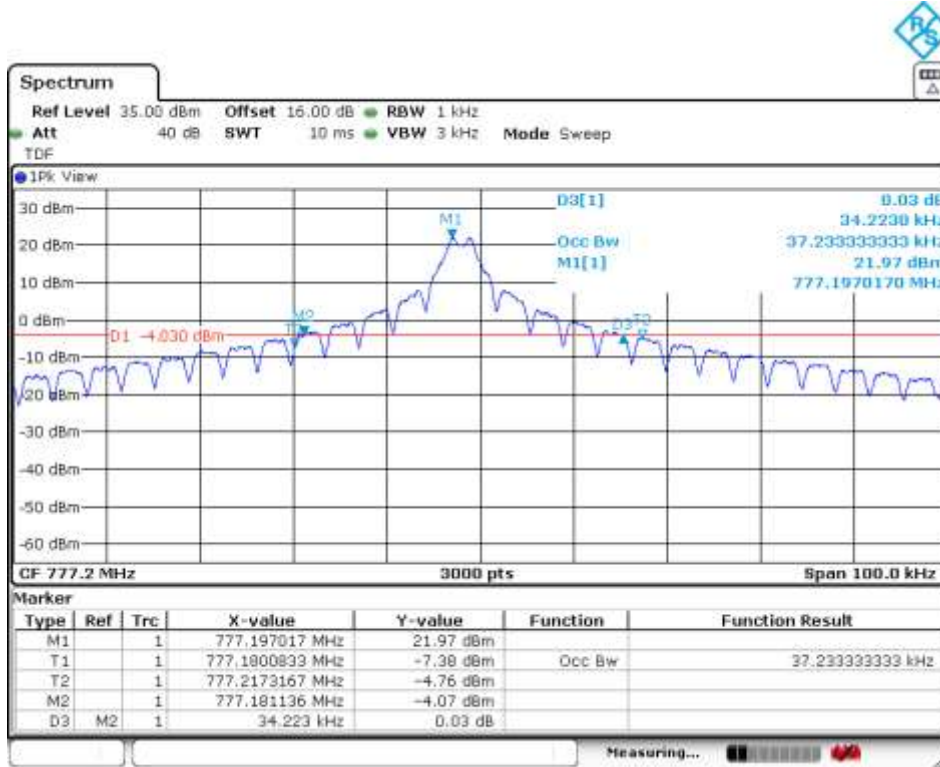

Middle Channel

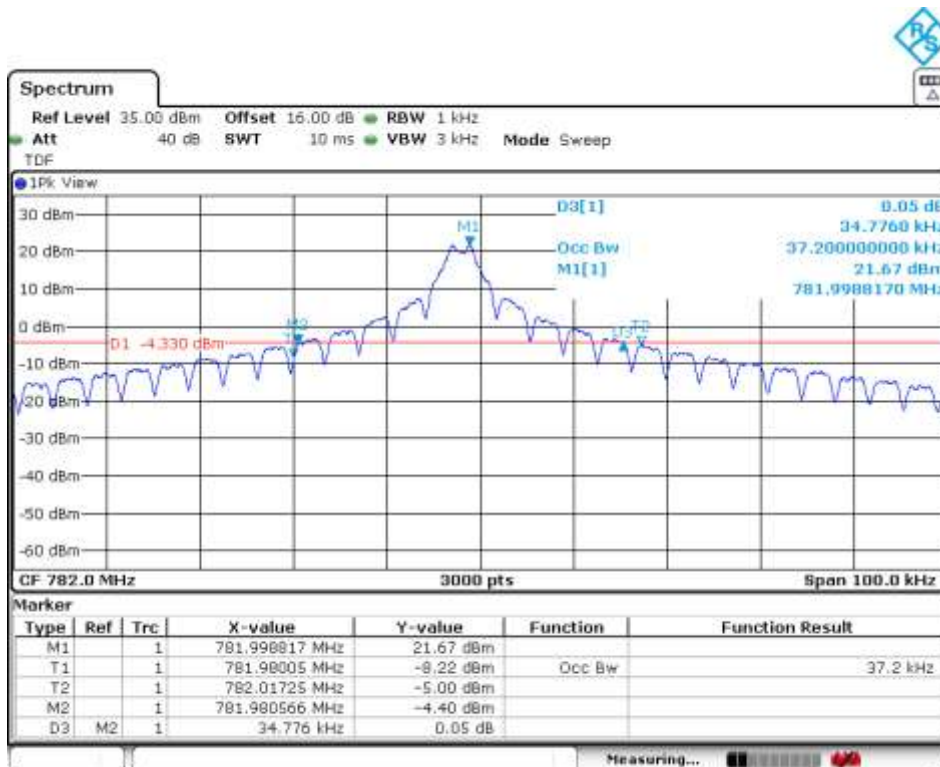

Highest Channel



Tone 3.75 kHz.  $\pi/4$  - QPSK MODULATION

Lowest Channel

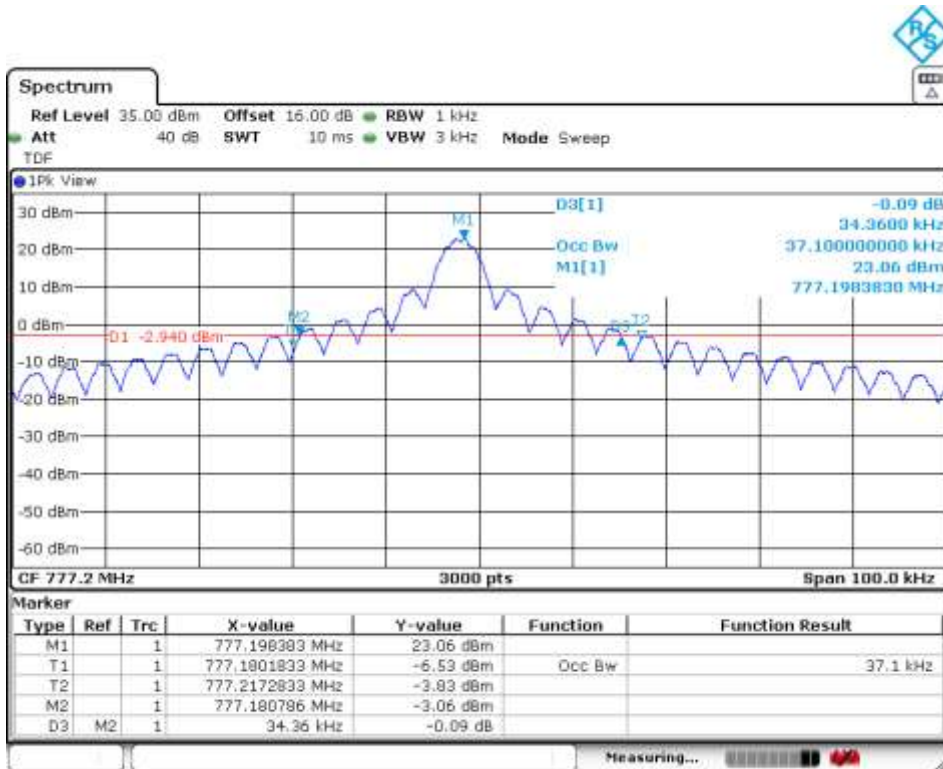

Middle Channel

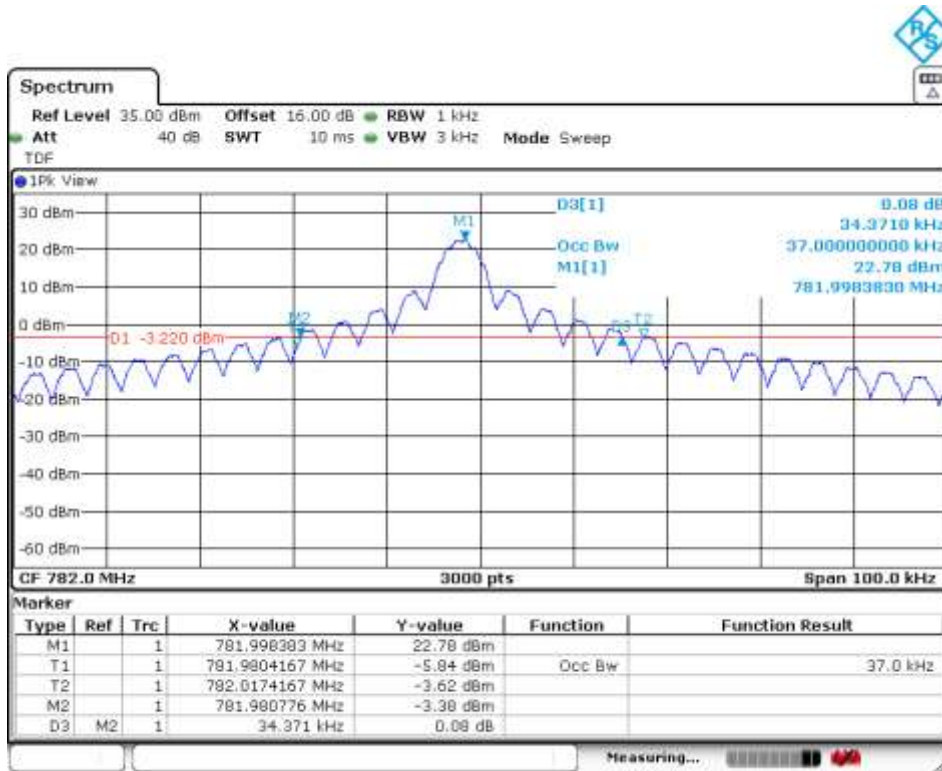

Highest Channel

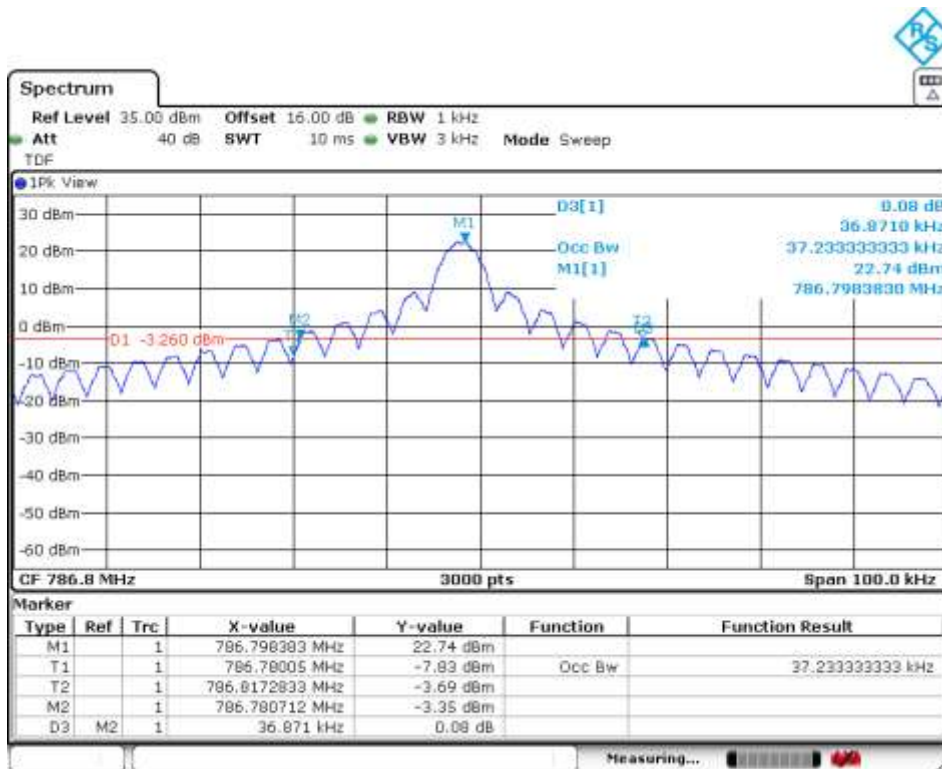

Tone 15 kHz.  $\pi/2$  - BPSK MODULATION  
 Lowest Channel

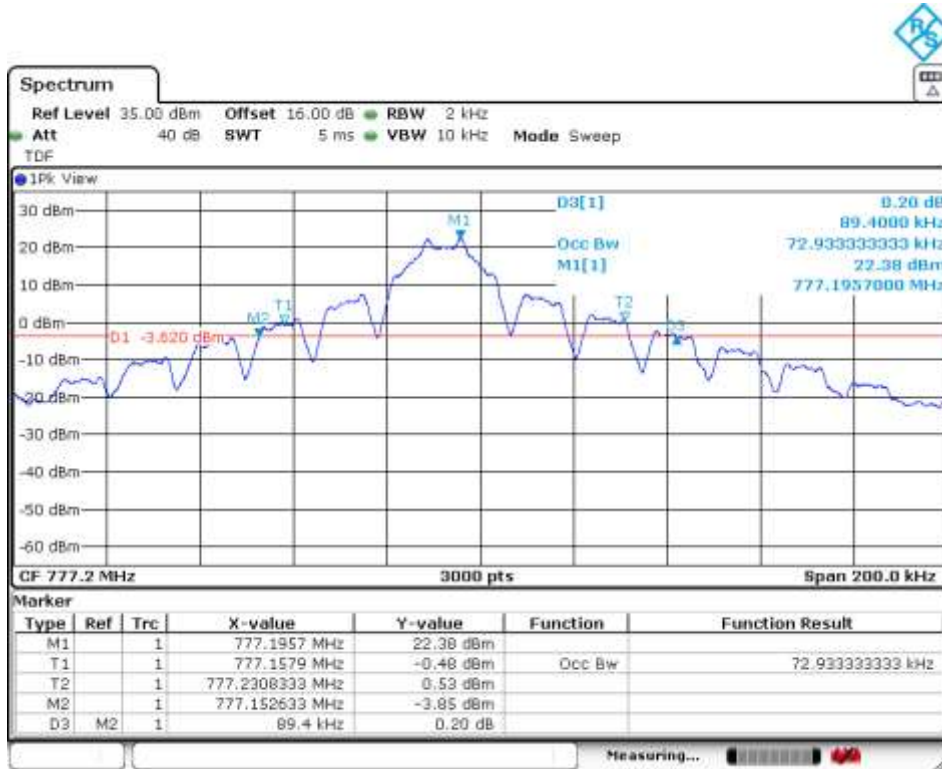

Middle Channel

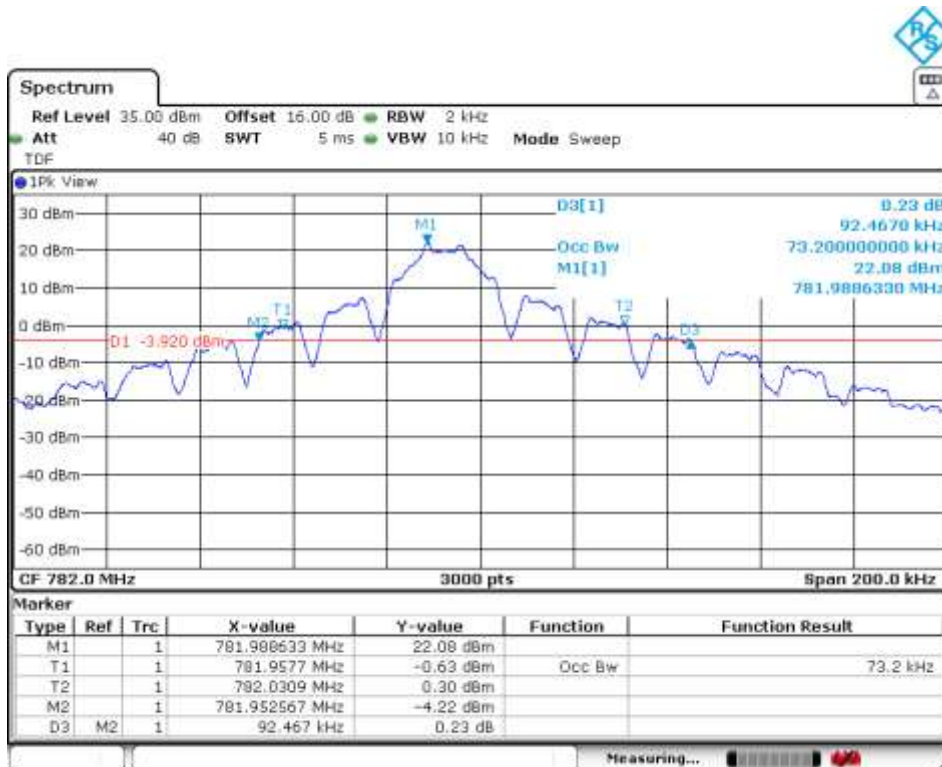

Highest Channel

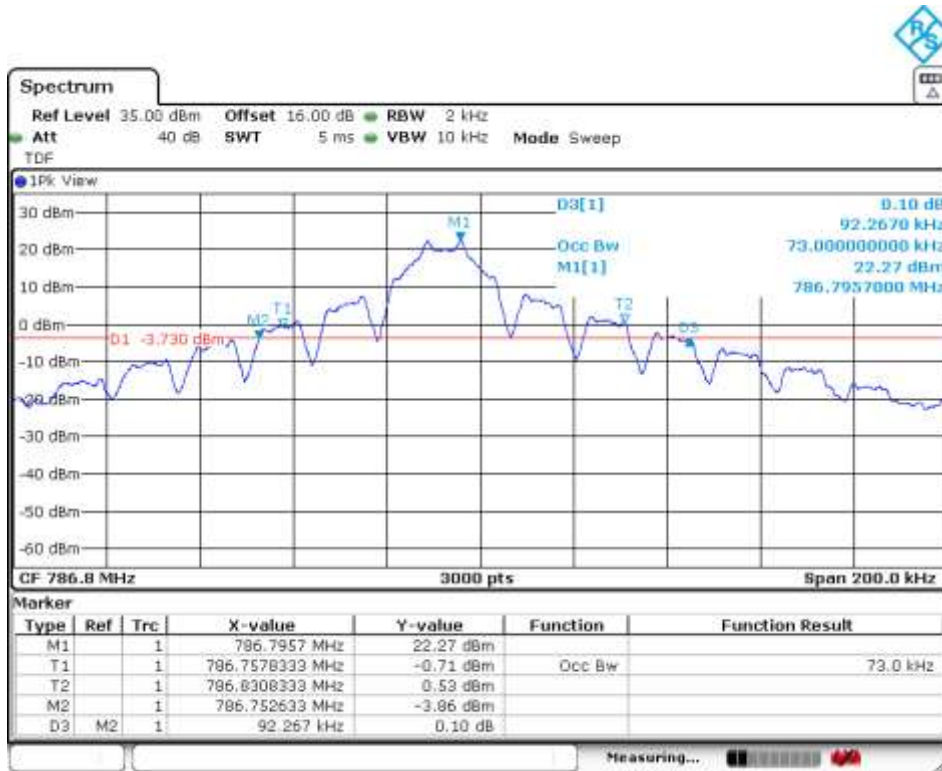

12 Tones 15 kHz.  $\pi/4$  - QPSK MODULATION

Lowest Channel

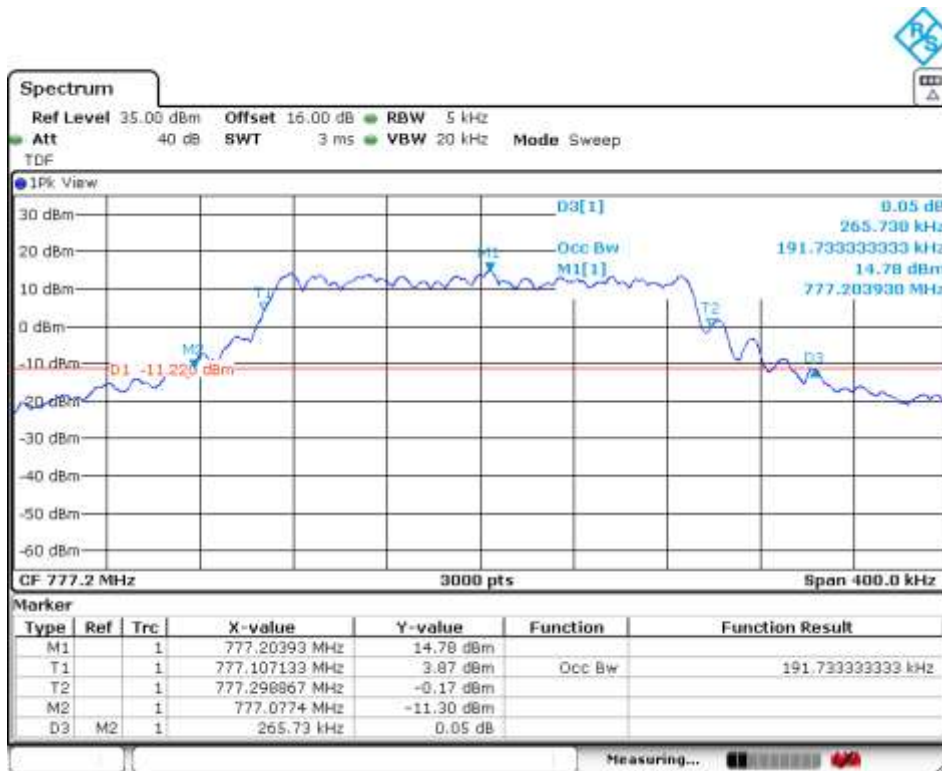

Middle Channel

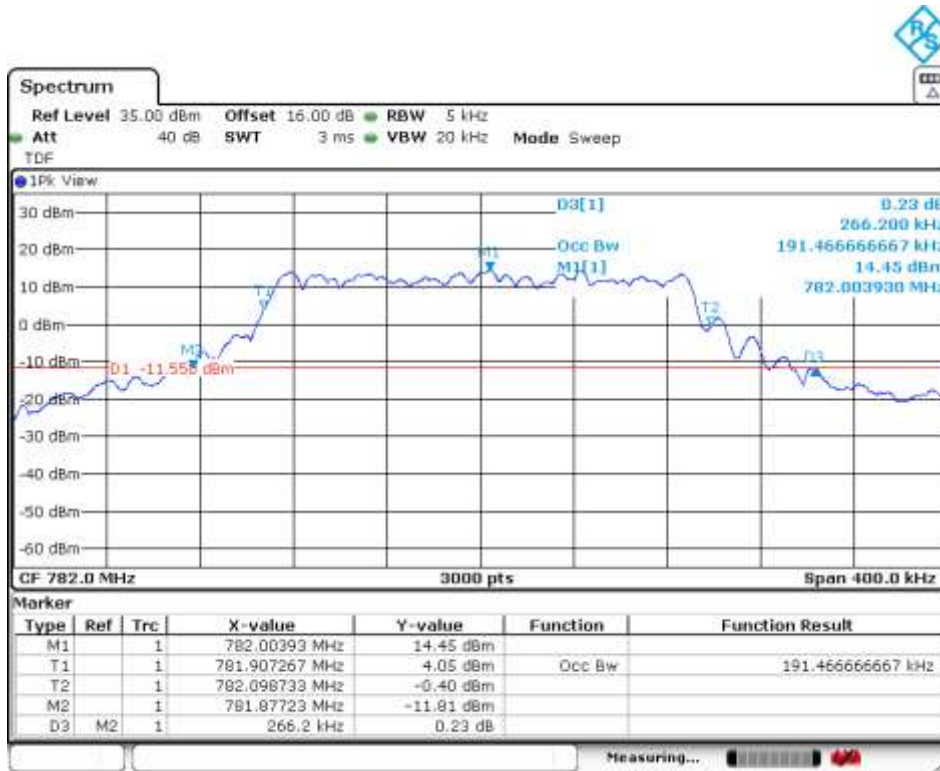

Highest Channel

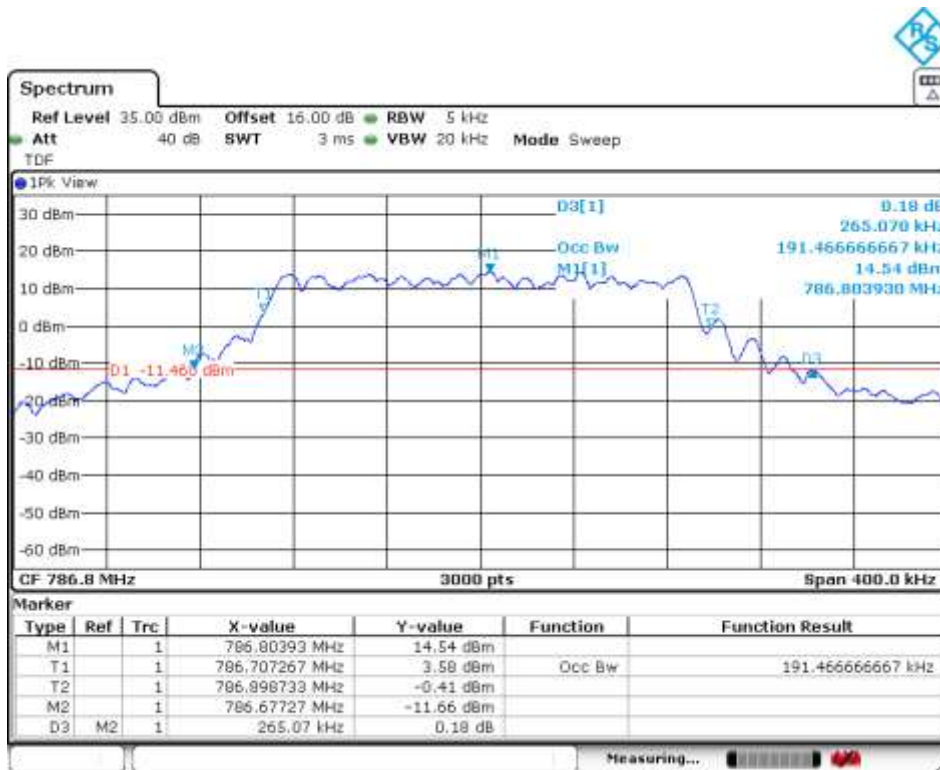

NB-IoT BAND 66.

Tone 3.75 kHz.  $\pi/2$  - BPSK MODULATION

Lowest Channel

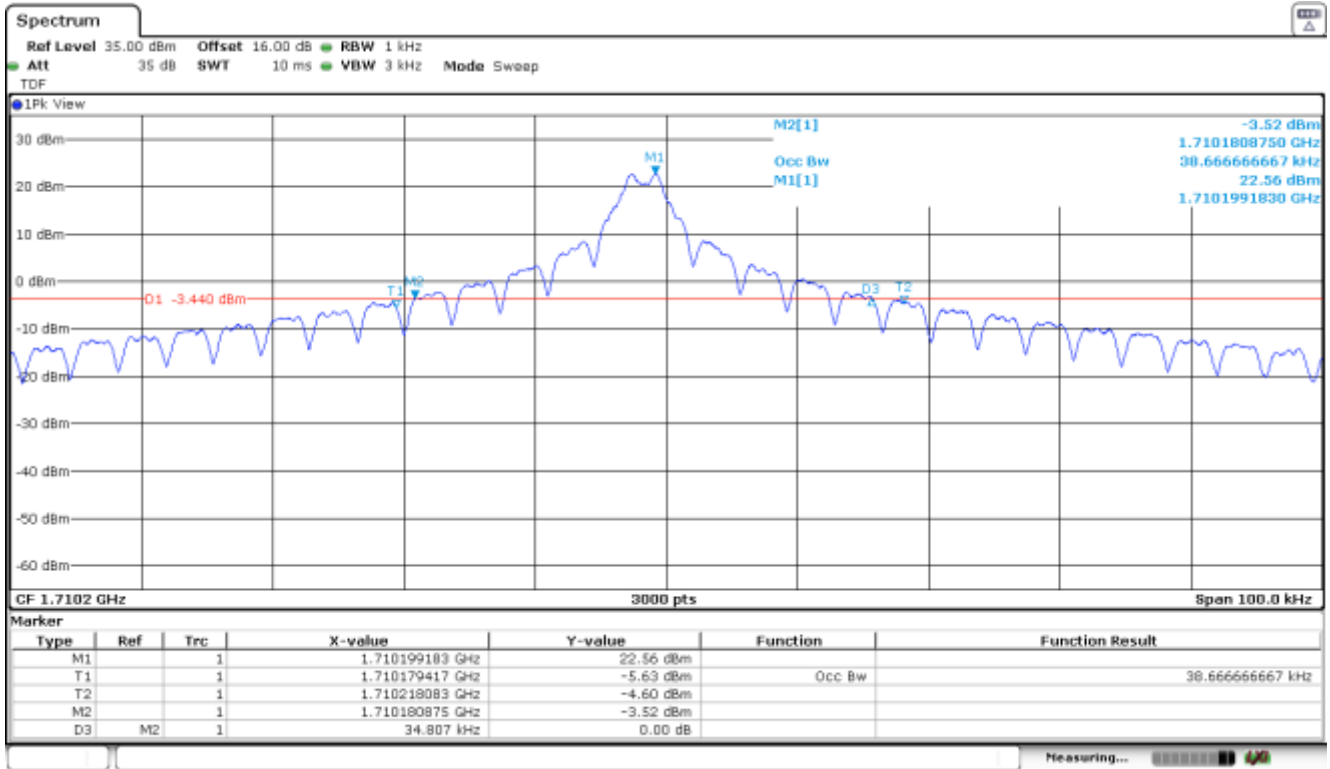

Middle Channel

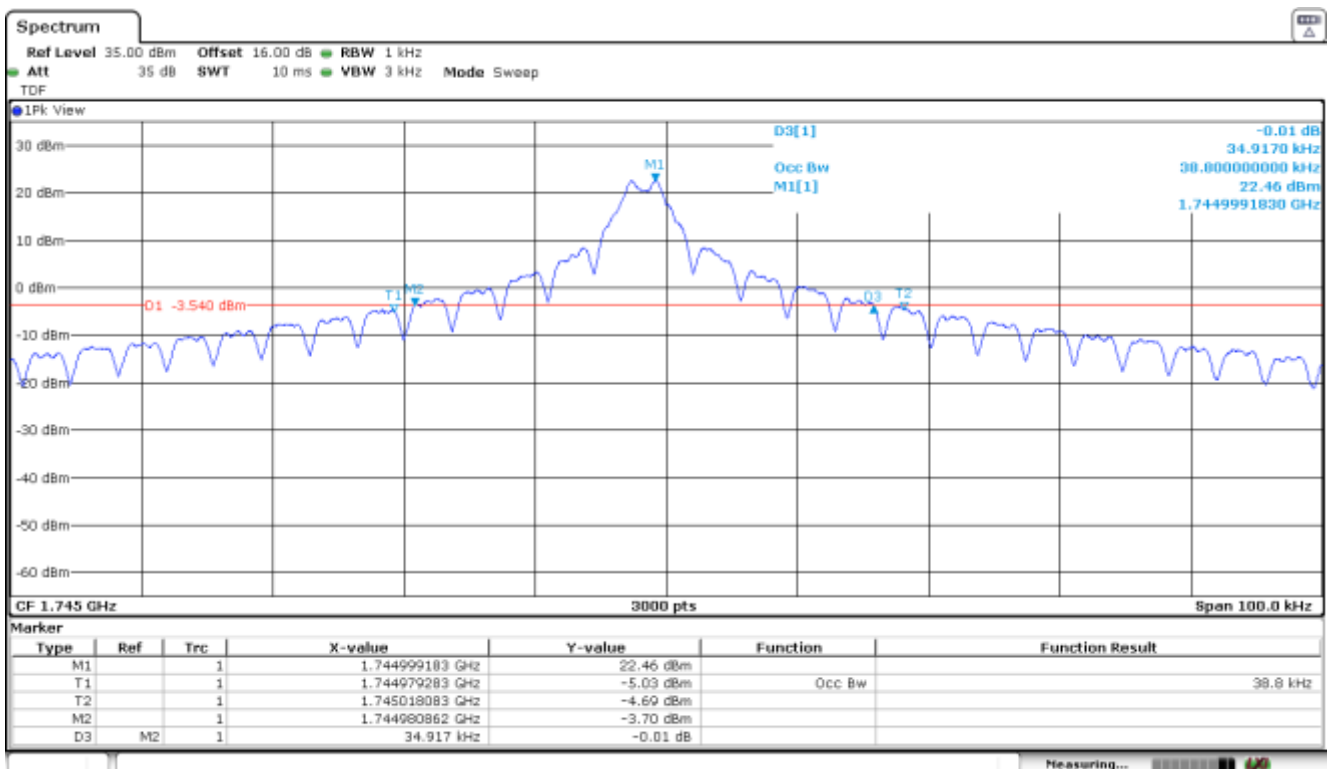

### Highest Channel

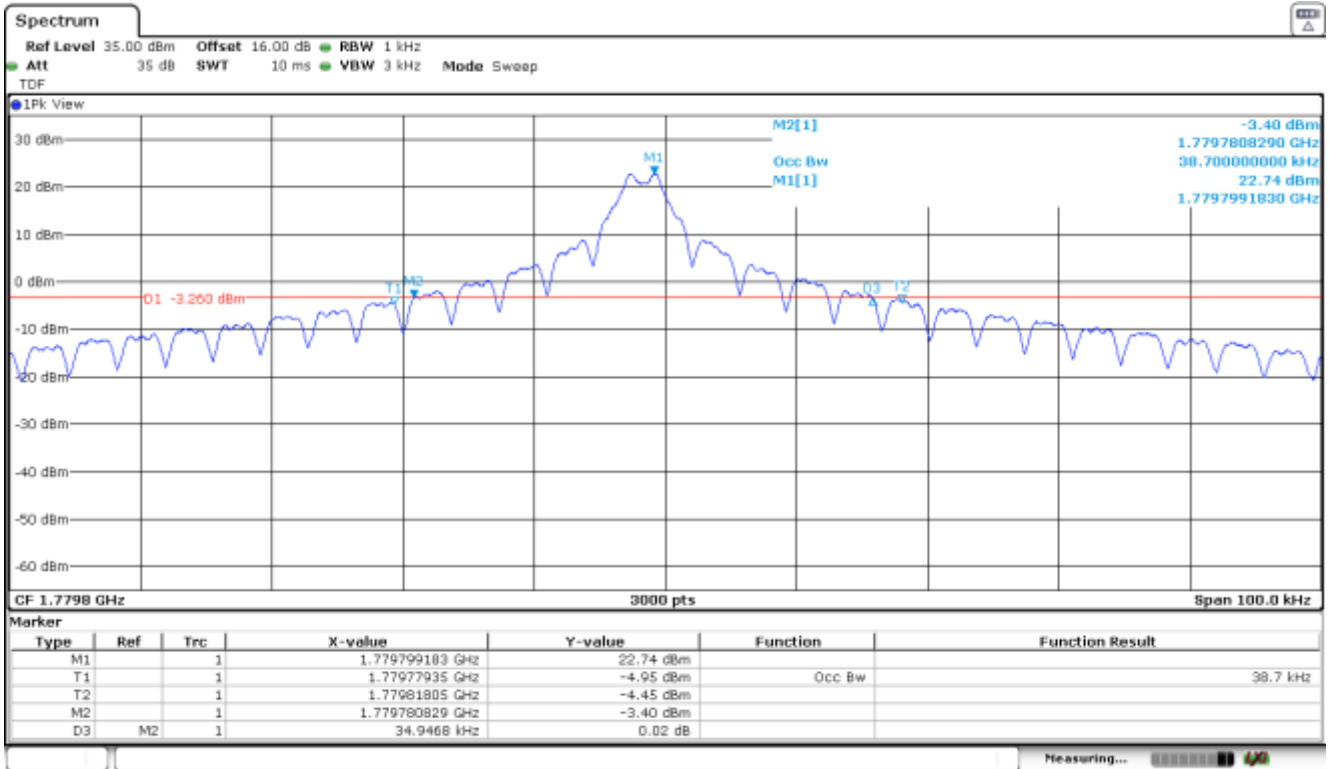

### Tone 3.75 kHz. $\pi/4$ - QPSK MODULATION

### Lowest Channel

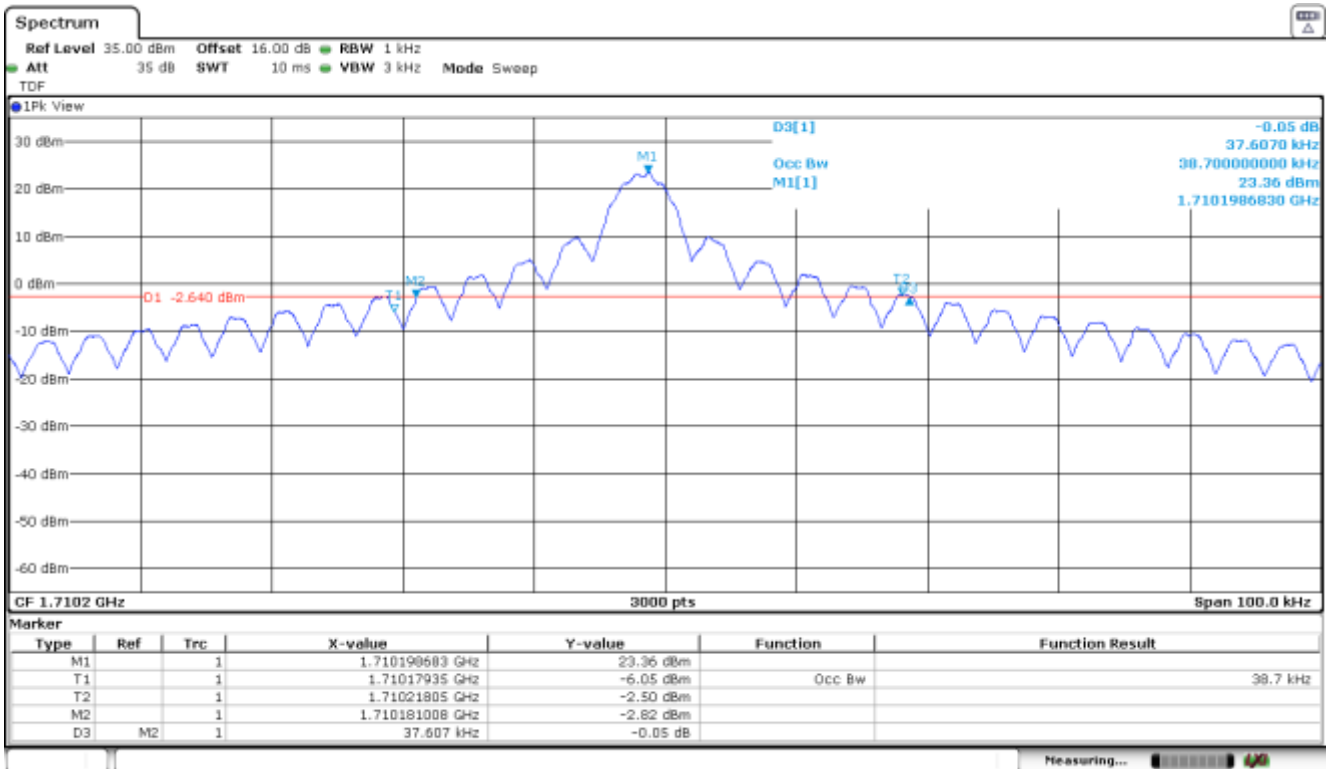



### Middle Channel

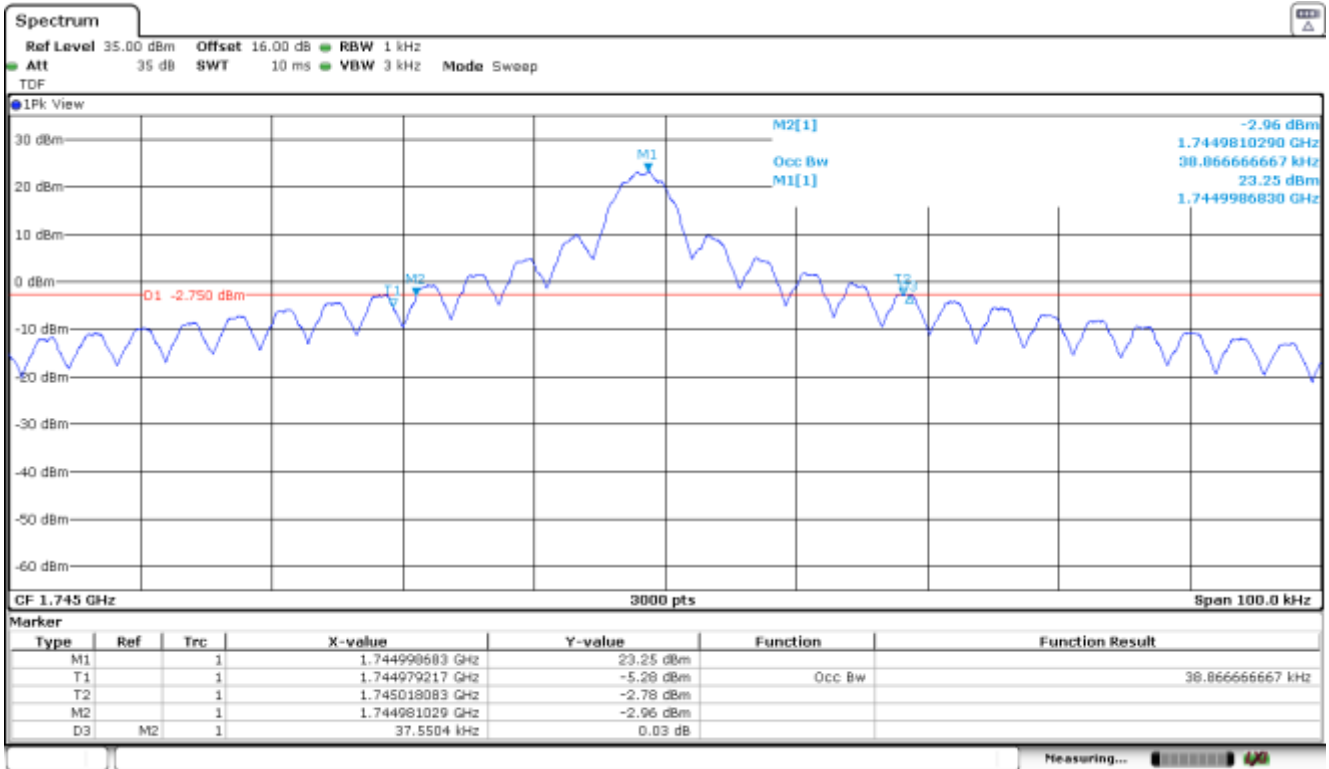

### Highest Channel

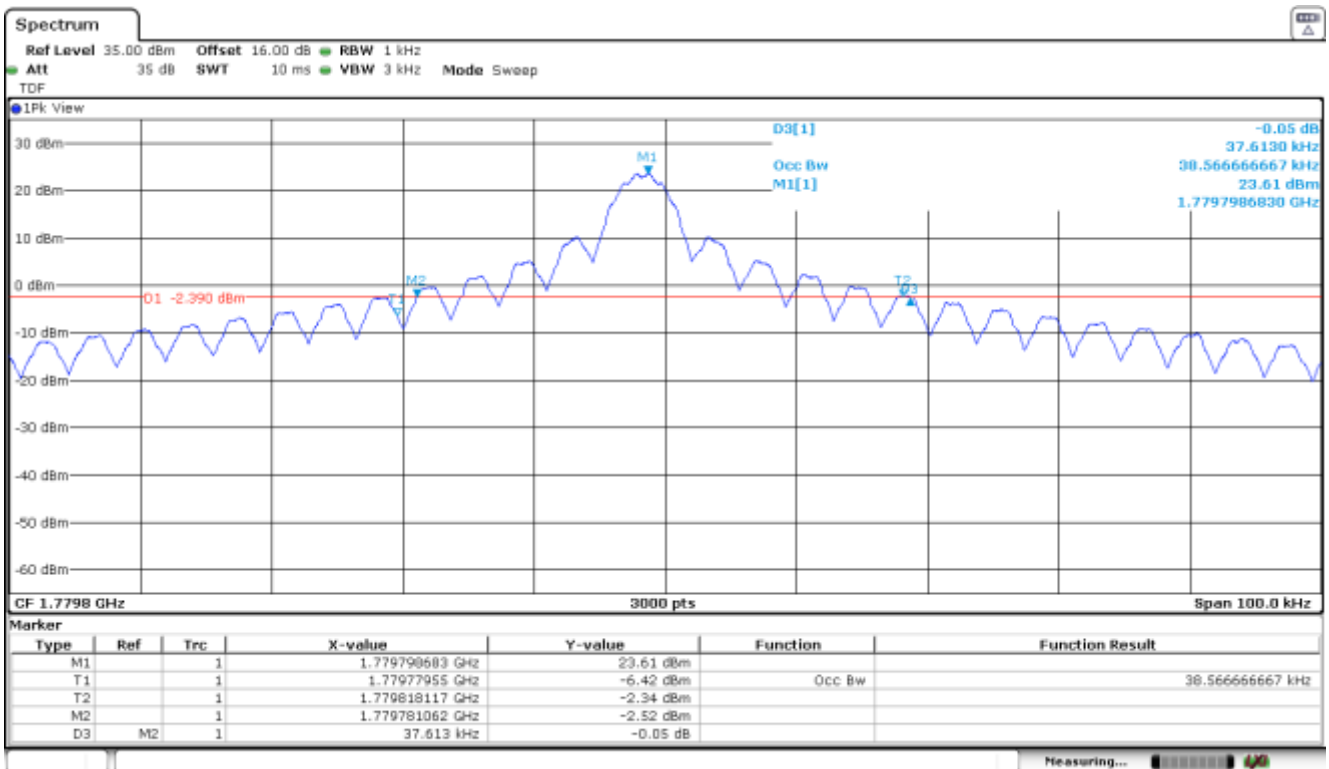

Tone 15 kHz.  $\pi/2$  - BPSK MODULATION

Lowest Channel

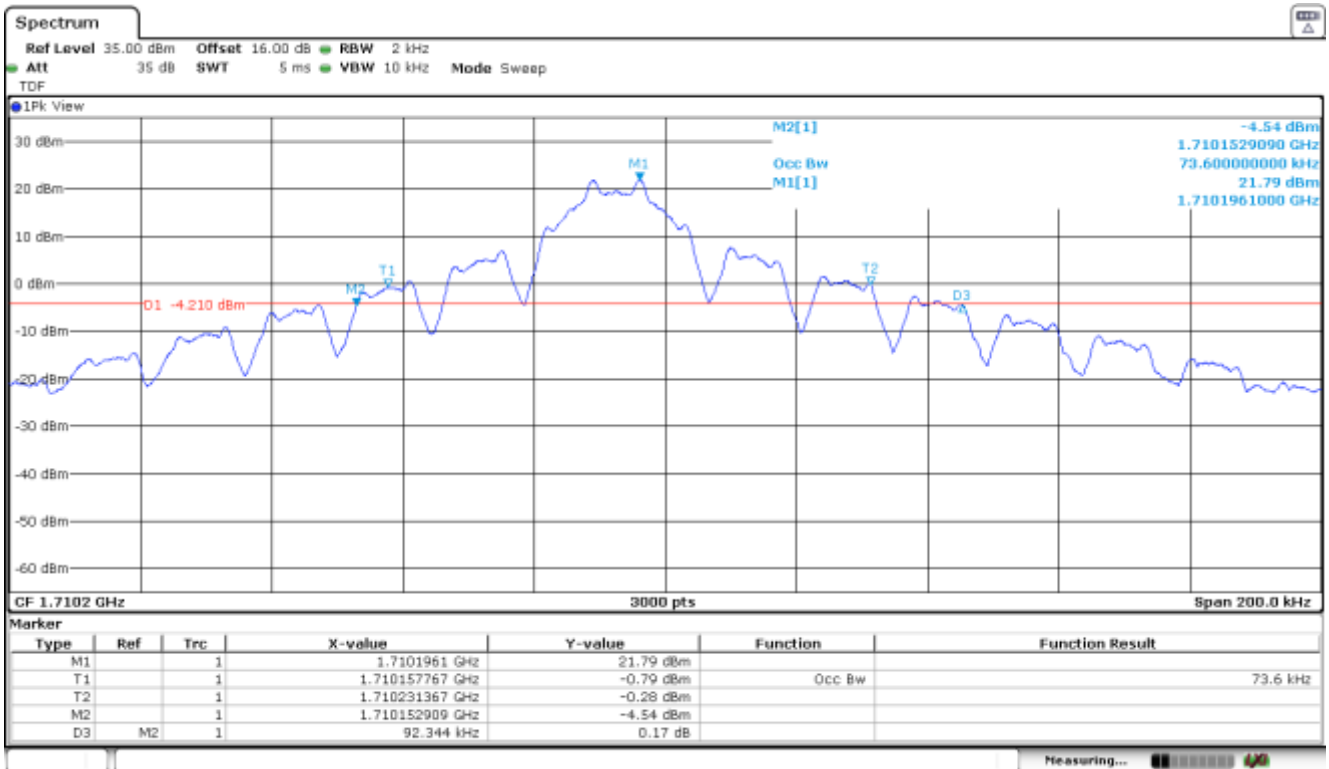

Middle Channel

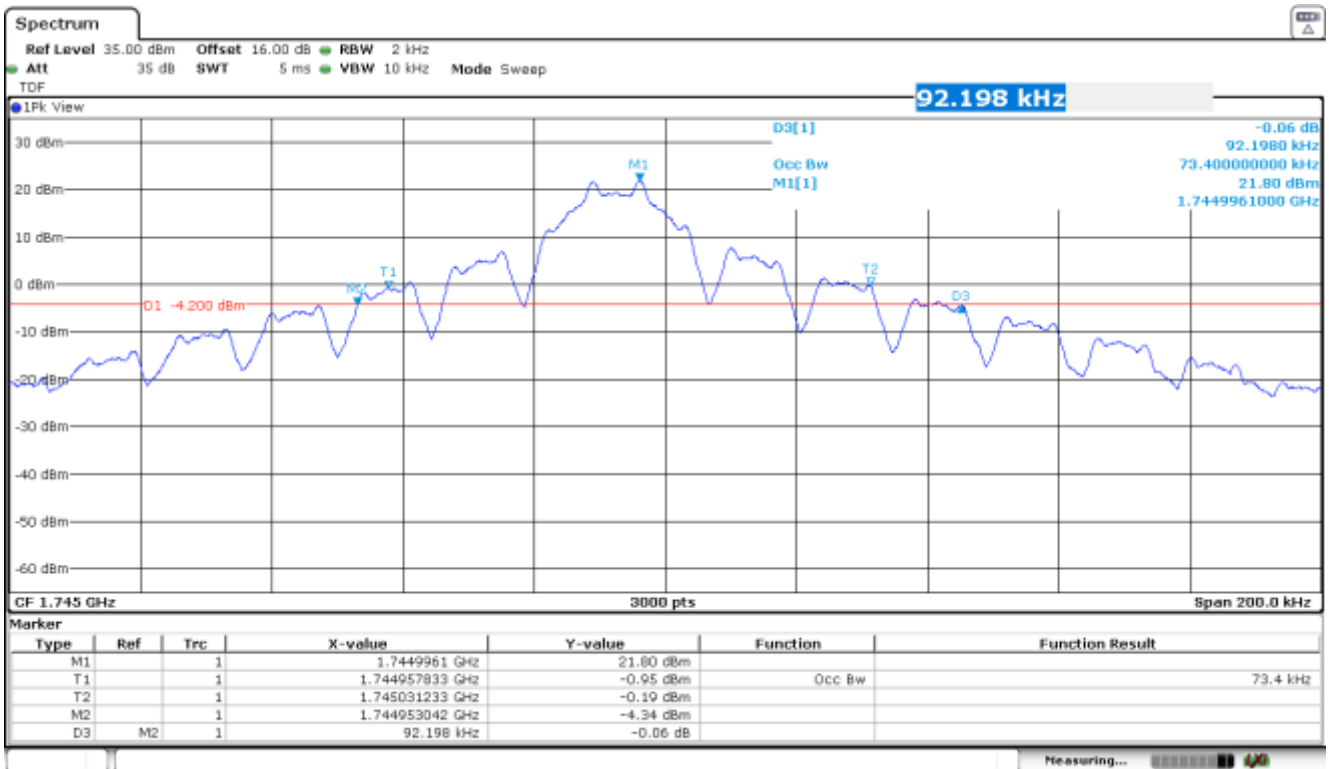

### Highest Channel

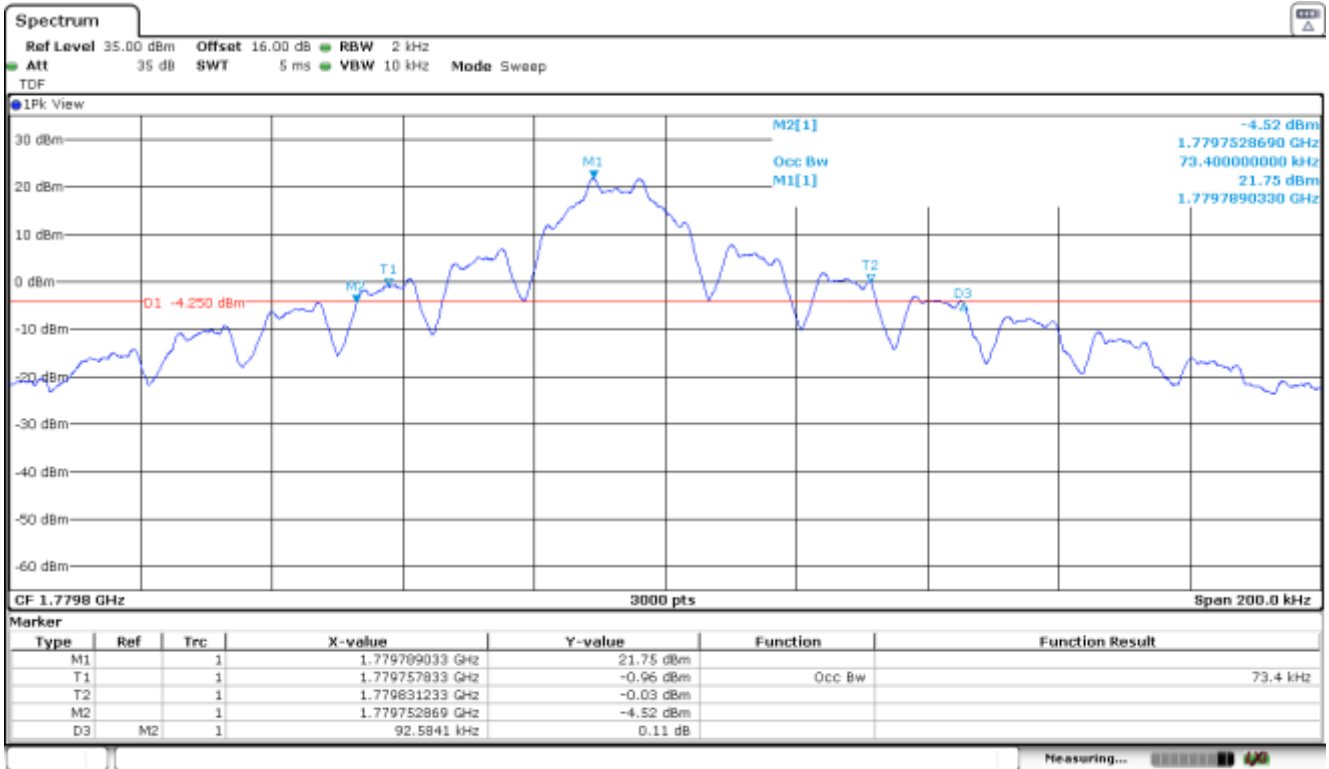

### 12 Tones 15 kHz. $\pi/4$ - QPSK MODULATION

### Lowest Channel

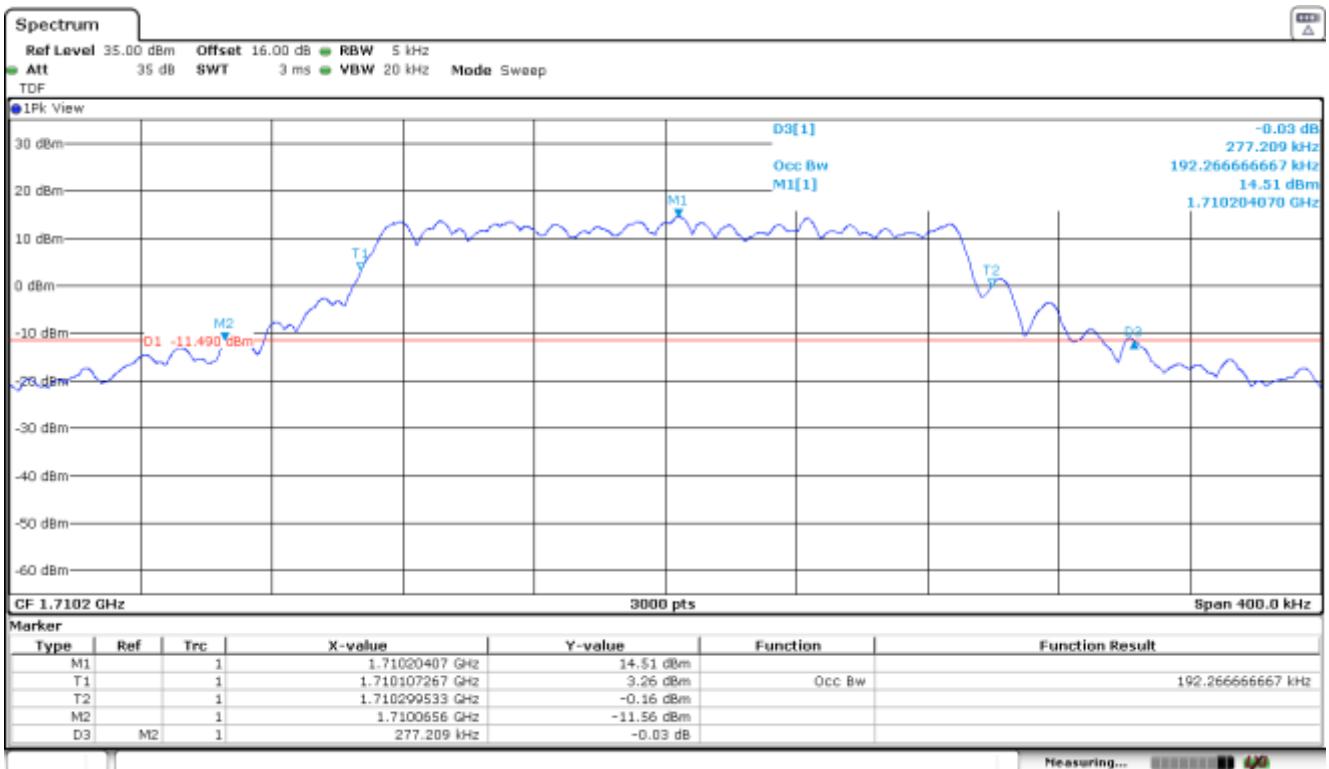

### Middle Channel

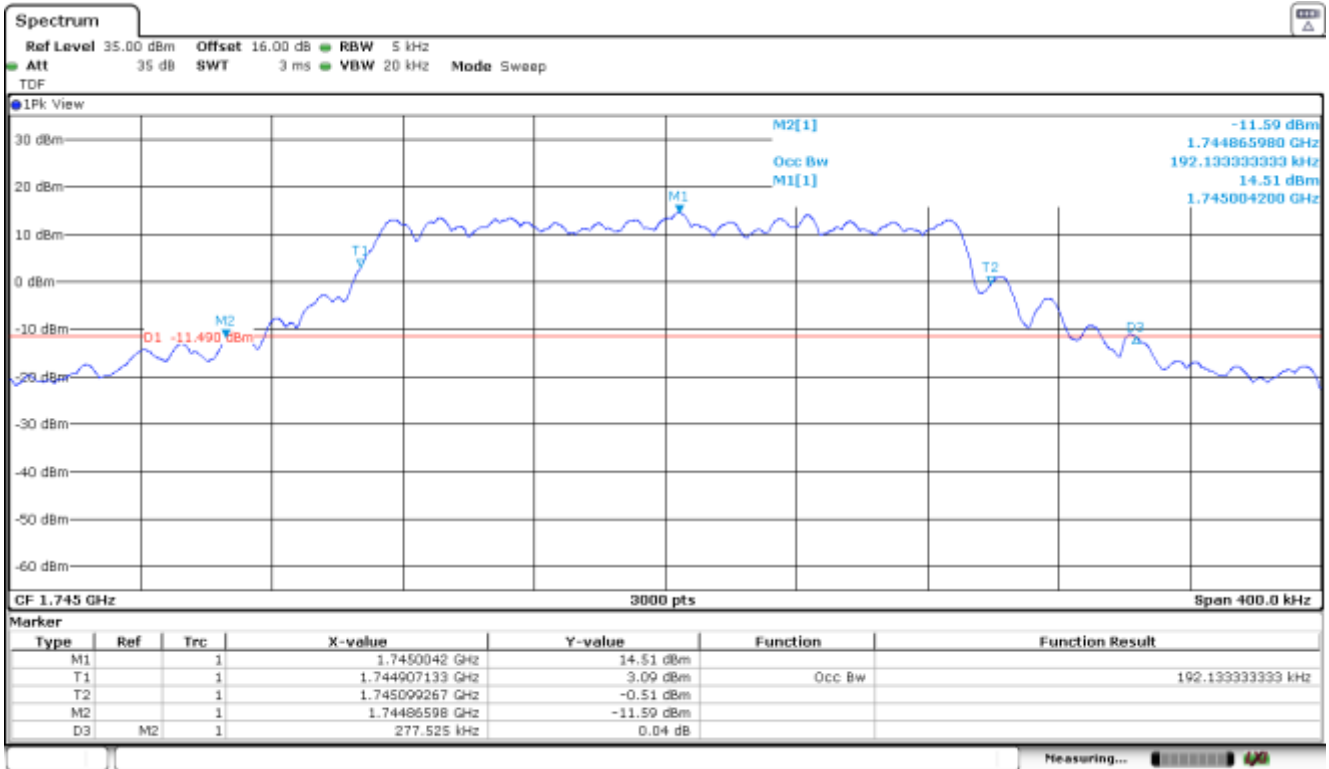

### Highest Channel

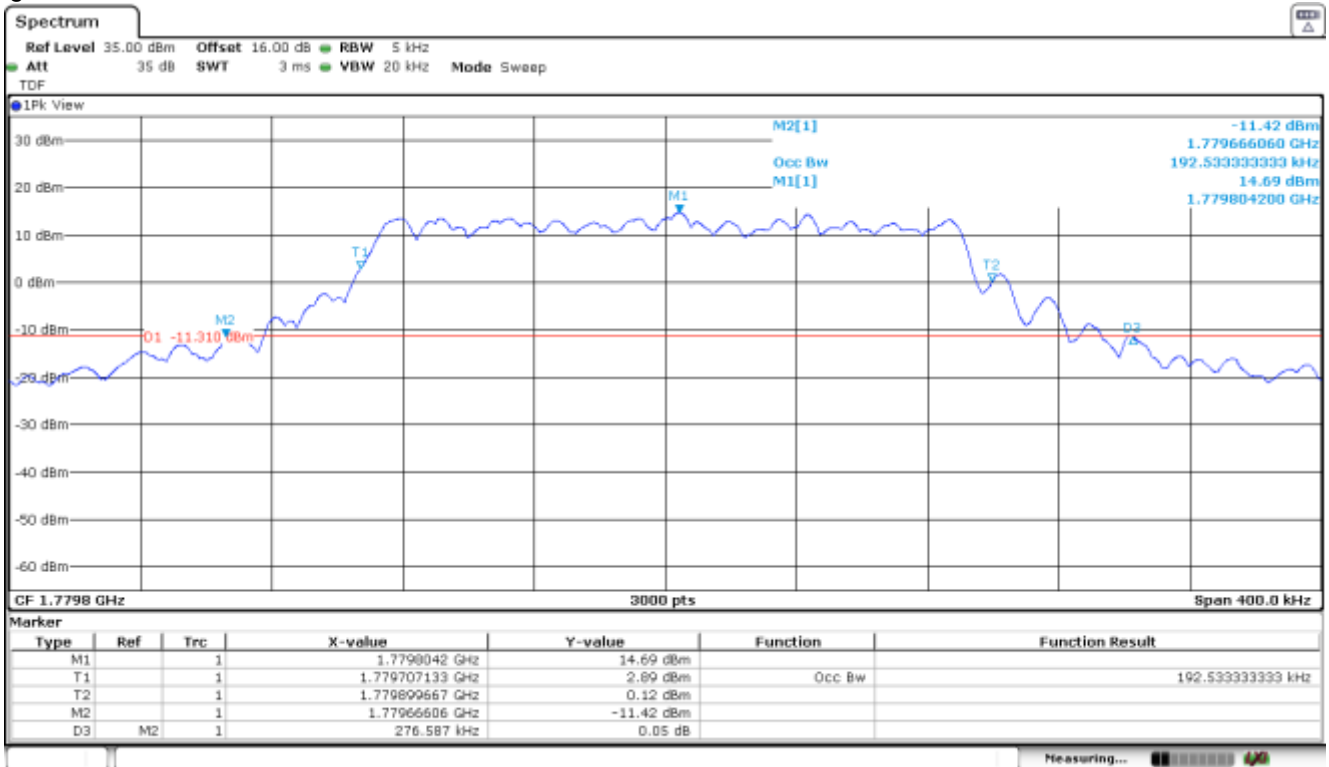

NB-IoT BAND 85.

Tone 3.75 kHz.  $\pi/2$  - BPSK MODULATION

Lowest Channel

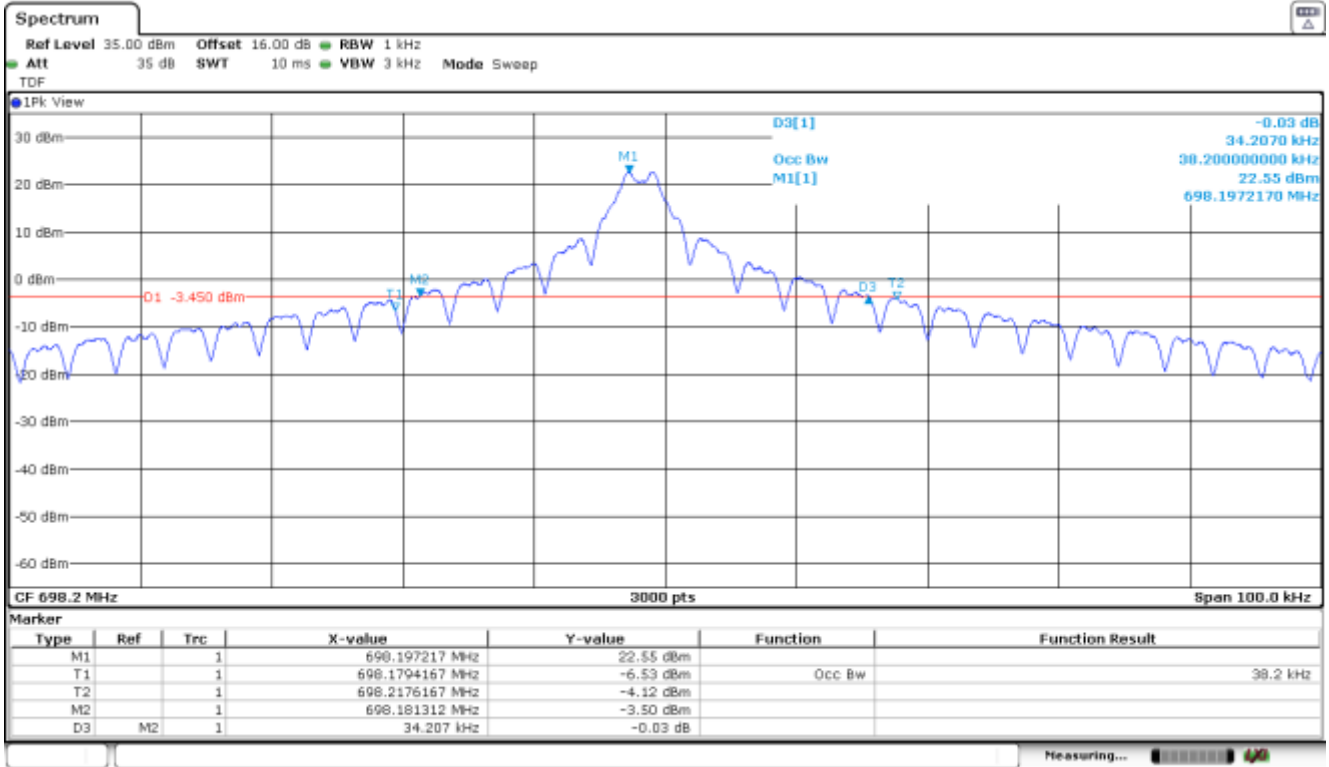

Middle Channel

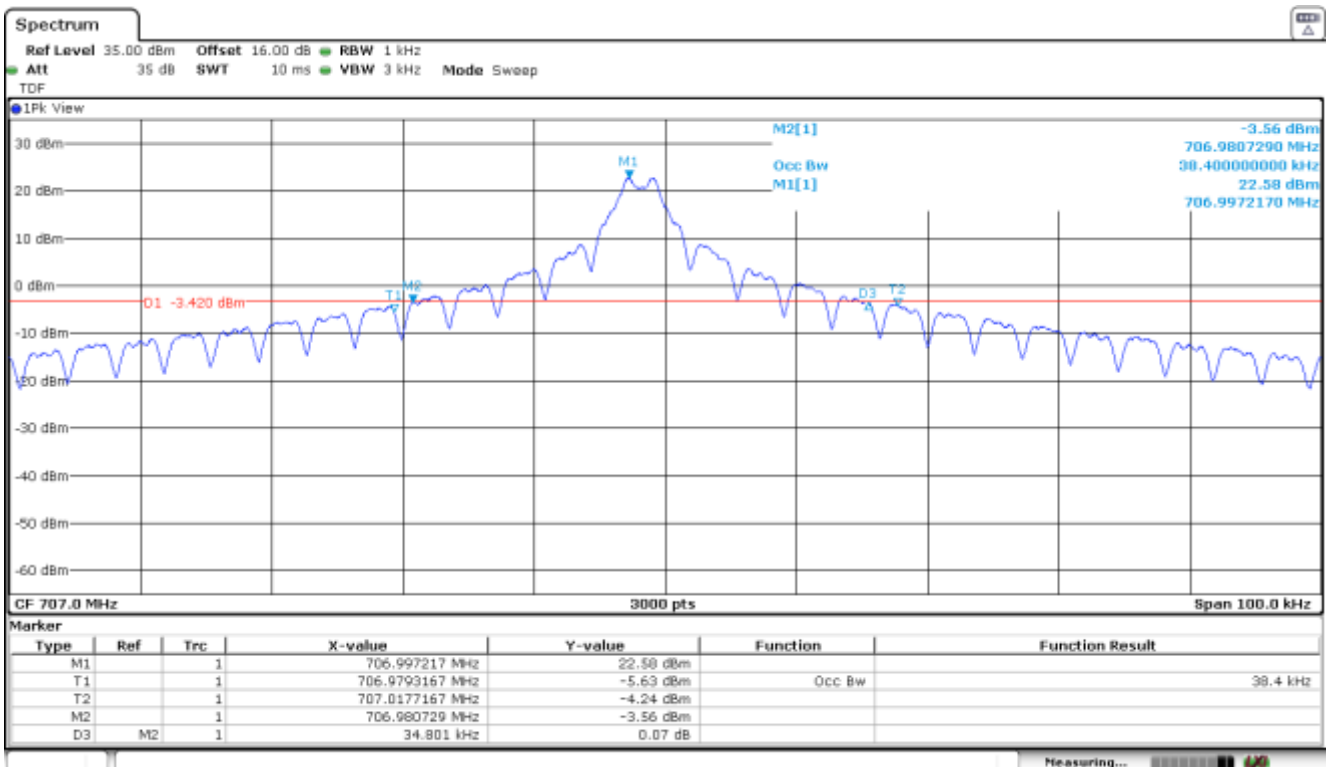

### Highest Channel

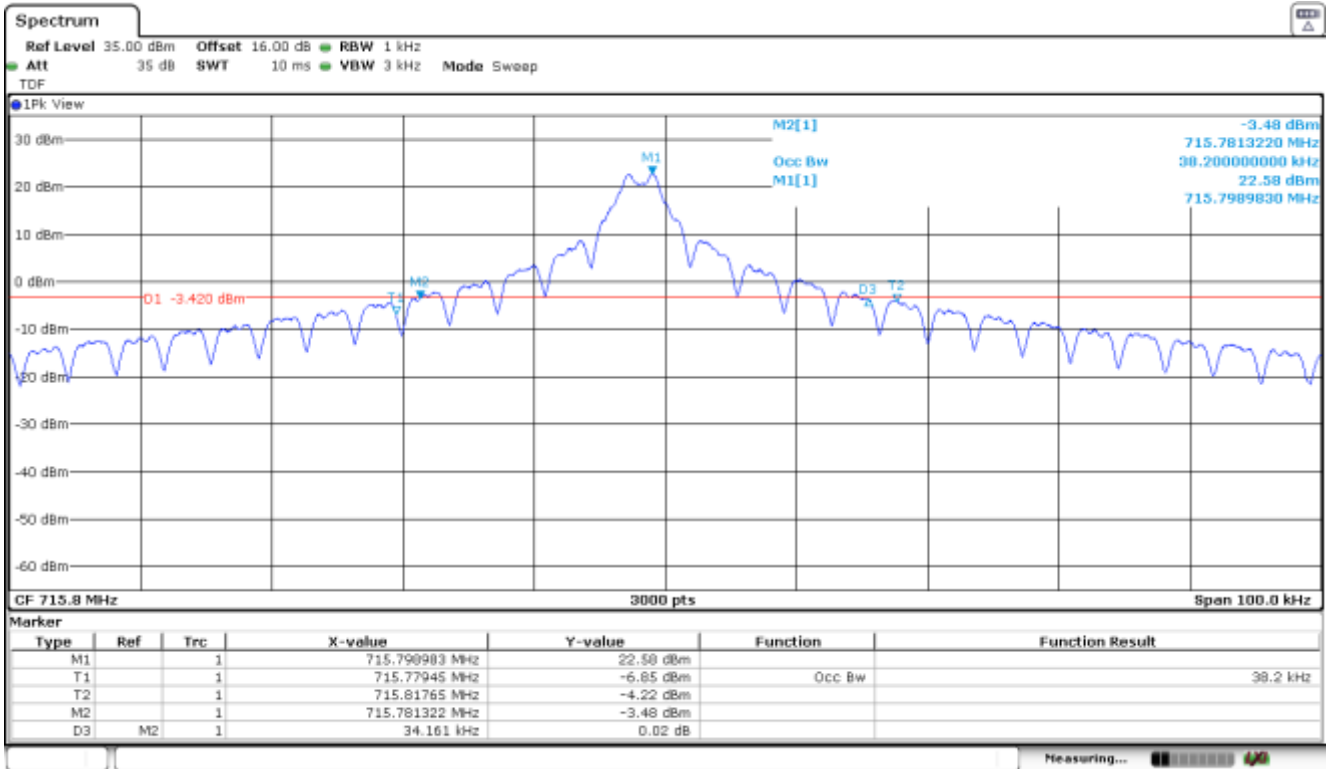

### Tone 3.75 kHz. $\pi/4$ - QPSK MODULATION

### Lowest Channel

