

Appendix C: Test results for FCC Part 27 / RSS-139 / RSS-130

INDEX

TEST CONDITIONS.....	123
RF Output Power	125
Frequency Stability	141
Modulation Characteristics	147
Occupied Bandwidth	152
Spurious emissions at antenna terminals.....	180
Spurious emissions at antenna terminals at Block Edges.....	202
Radiated emissions	220

TEST CONDITIONS

Power supply (V):

Vnominal = 3.8 Vdc

Type of power supply = DC Voltage from external power supply

Type of antenna = external antenna.

Declared Gain for antenna = +2.15dBi for all bands.

TEST FREQUENCIES:

NBLoT. $\pi/2$ - BPSK AND $\pi/4$ - QPSK MODULATION (BAND 4)

Channel (Frequency. MHz)		
Lowest	Middle	Highest
19952	20175	20398
(1710.2)	(1732.5)	(1754.8)

NOTE: Band 4 is completely included in band 66. so the channels of band 66 were tested to give conformity to the assigned block

NBLoT. $\pi/2$ - BPSK AND $\pi/4$ - QPSK MODULATION (BAND 12)

Channel (Frequency. MHz)		
Lowest	Middle	Highest
23012	23095	23178
(699.2)	(707.5)	(715.8)

NBLoT. $\pi/2$ - BPSK AND $\pi/4$ - QPSK MODULATION (BAND 13)

Channel (Frequency. MHz)		
Lowest	Middle	Highest
23182	23230	23278
(777.2)	(782)	(786.8)

NBLoT. $\pi/2$ - BPSK AND $\pi/4$ - QPSK MODULATION (BAND 66)

Channel (Frequency. MHz)		
Lowest	Middle	Highest
131974 (1710.2)	132322 (1745)	132670 (1779.8)

NBLoT. $\pi/2$ - BPSK AND $\pi/4$ - QPSK MODULATION (BAND 85)

Channel (Frequency. MHz)		
Lowest	Middle	Highest
134004 (698.2)	134092 (707)	134180 (715.8)

RF Output Power

SPECIFICATION

FCC §27.50 (c) (10).

Portable stations (hand-held devices) in the 600 MHz uplink band and the 698-746 MHz band. and fixed and mobile stations in the 600 MHz uplink band are limited to 3 watts ERP.

FCC §27.50 (b) (10).

Portable stations (hand-held devices) transmitting in the 746-757 MHz. 776-788 MHz. and 805-806 MHz bands are limited to 3 watts ERP.

RSS-130 Clause 4.6.

The e.r.p. shall not exceed 30 watts for mobile equipment and outdoor fixed subscriber equipment. The e.r.p. shall not exceed 3 watts for portable equipment and indoor fixed subscriber equipment.

FCC §27.50 (d) (4). RSS-139 Clause 6.5.

Fixed. mobile. and portable (hand-held) stations operating in the 1710-1755 MHz band are limited to 1 watt EIRP (30 dBm). Fixed stations operating in the 1710-1755 MHz band are limited to a maximum antenna height of 10 meters above ground. Mobile and portable stations operating in these bands must employ a means for limiting power to the minimum necessary for successful communications.

METHOD

The conducted RF output power measurements were made at the RF output terminals of the EUT using the power meter of the Universal Radio Communication tester R&S CMW500. selecting maximum transmission power of the EUT and different modes of modulation.

The maximum equivalent isotropically radiated power (e.i.r.p.) is calculated by adding the declared maximum antenna gain (dBi).

The maximum effective radiated power e.r.p. is calculated from the maximum equivalent isotropically radiated power (e.i.r.p.) by subtracting 2.15 dB:

$$E.R.P. = E.I.R.P. - 2.15 \text{ dB}$$

The EUT was controlled via the Universal Radio Communication tester R&S CMW500 selecting maximum transmission power of the EUT and different modes of modulation.

TEST SETUP

Conducted average power.



RESULTS

MAXIMUM OUTPUT POWER (CONDUCTED).

NB IoT. BAND 4.

Ch	Freq. (MHz)	Modulation	BW (kHz)	Num. tone	Offset Tone	Average Power (dBm)	PAPR (dB)
19950	1710.2	$\pi/2$ - BPSK	3.75	1	0	22.31	(*)
				1	47	22.54	(*)
			15	1	0	22.48	(*)
				1	11	22.38	(*)
		$\pi/4$ - QPSK	3.75	1	0	22.38	(*)
				1	47	22.3	(*)
			15	1	0	22.39	(*)
				1	11	22.36	(*)
				3	0	21.86	4.9
				3	6	22.19	4.49
				6	0	21.34	5.99
				6	6	21.37	6.08
12	0	20.68	6.83				
20175	1732.5	$\pi/2$ - BPSK	3.75	1	0	22.31	(*)
				1	47	22.54	(*)
			15	1	0	22.48	(*)
				1	11	22.38	(*)
		$\pi/4$ - QPSK	3.75	1	0	22.38	(*)
				1	47	22.3	(*)
			15	1	0	22.39	(*)
				1	11	22.36	(*)
				3	0	21.86	4.49
				3	6	22.19	4.47
				6	0	21.34	6.17
				6	6	21.37	6.23
12	0	20.68	6.65				
20398	1754.2	$\pi/2$ - BPSK	3.75	1	0	22.31	(*)
				1	47	22.54	(*)
			15	1	0	22.48	(*)
				1	11	22.38	(*)
		$\pi/4$ - QPSK	3.75	1	0	22.38	(*)
				1	47	22.3	(*)
			15	1	0	22.39	(*)
				1	11	22.36	(*)
				3	0	21.86	4.42
				3	6	22.19	4.45
				6	0	21.34	6.19
				6	6	21.37	5.96
12	0	20.68	6.63				

(*): Preliminary measurements determined that 3, 6 or 12 tones of 15kHz as the worst case. The results in the next tables shows the results for this configuration.

NBLoT. BAND 12.

Ch	Freq. (MHz)	Modulation	BW (kHz)	Num. tone	Offset Tone	Average Power (dBm)	PAPR (dB)
23012	699.2	$\pi/2$ - BPSK	3.75	1	0	22.43	(*)
				1	47	22.42	(*)
			15	1	0	22	(*)
				1	11	22.6	(*)
		$\pi/4$ - QPSK	3.75	1	0	22.48	(*)
				1	47	22.57	(*)
			15	1	0	22.85	(*)
				1	11	22.22	(*)
				3	0	22.52	3.73
				3	6	23.27	3.65
				6	0	21.78	5.27
				6	6	21.78	5.3
		12	0	20.83	5.69		
		23095	707.5	$\pi/2$ - BPSK	3.75	1	0
1	47					22.85	(*)
15	1				0	23.12	(*)
	1				11	23.11	(*)
$\pi/4$ - QPSK	3.75			1	0	22.88	(*)
				1	47	22.91	(*)
	15			1	0	23.2	(*)
				1	11	23.14	(*)
				3	0	22.64	4.1
				3	6	23.21	3.87
				6	0	21.86	5.48
				6	6	21.91	5.4
12	0			20.88	6.06		
23178	715.8			$\pi/2$ - BPSK	3.75	1	0
		1	47			22.79	(*)
		15	1		0	22.91	(*)
			1		11	22.84	(*)
		$\pi/4$ - QPSK	3.75	1	0	22.83	(*)
				1	47	22.83	(*)
			15	1	0	22.8	(*)
				1	11	22.78	(*)
				3	0	22.28	4.09
				3	6	23.1	4.08
				6	0	21.6	5.67
				6	6	21.61	5.66
		12	0	20.64	6.22		

(*): Preliminary measurements determined that 3, 6 or 12 tones of 15kHz as the worst case. The results in the next tables shows the results for this configuration.

NBLoT. BAND 13.

Ch	Freq. (MHz)	Modulation	BW (kHz)	Num. tone	Offset Tone	Average Power (dBm)	PAPR (dB)
23182	777.20	$\pi/2$ - BPSK	3.75	1	0	22.78	(*)
				1	47	22.74	(*)
			15	1	0	22.77	(*)
				1	11	22.73	(*)
		$\pi/4$ - QPSK	3.75	1	0	22.79	(*)
				1	47	22.81	(*)
			15	1	0	22.88 (***)	(*)
				1	11	22.83 (**)	(*)
				3	0	22.05	4.54
				3	6	22.51	4.58
				6	0	21.51	6.36
				6	6	21.51	6.3
				12	0	20.54	6.68
				23230	782	$\pi/2$ - BPSK	3.75
1	47	22.66	(*)				
15	1	0	22.73				(*)
	1	11	22.75				(*)
$\pi/4$ - QPSK	3.75	1	0			22.65	(*)
		1	47			22.67	(*)
	15	1	0			22.77	(*)
		1	11			22.71	(*)
		3	0			22.1	4.54
		3	6			22.52	4.56
		6	0			21.54	6.39
		6	6			21.57	6.25
		12	0			20.6	6.67
		23278	786.8			$\pi/2$ - BPSK	3.75
1	47			22.74	(*)		
15	1			0	22.62		(*)
	1			11	22.73		(*)
$\pi/4$ - QPSK	3.75			1	0	22.8	(*)
				1	47	22.79	(*)
	15			1	0	22.8	(*)
				1	11	22.64	(*)
				3	0	22.04	4.45
				3	6	22.47	4.58
				6	0	21.52	6.33
				6	6	21.53	6.31
				12	0	20.52	6.59

(*): Preliminary measurements determined that 3. 6 or 12 tones of 15kHz as the worst case. The results in the next tables shows the results for this configuration.

(**) Average power measurement in Sample 01.

(***): Average power measurement in Sample 02.

NBLoT. BAND 66.

Ch	Freq. (MHz)	Modulation	BW (kHz)	Num. tone	Offset Tone	Average Power (dBm)	PAPR (dB)	
131974	1710.2	$\pi/2$ - BPSK	3.75	1	0	23.71	(*)	
				1	47	23.72(***) 23.01(**)	(*)	
			15	1	0	23.68	(*)	
				1	11	23.64	(*)	
			$\pi/4$ - QPSK	3.75	1	0	23.69	(*)
					1	47	23.68	(*)
		15		1	0	23.68	(*)	
				1	11	23.66	(*)	
				3	0	23.22	4.37	
				3	6	23.57	4.38	
		6	0	22.72	6.16			
		6	6	22.74	6.07			
		12	0	22.04	6.68			
		132322	1745	$\pi/2$ - BPSK	3.75	1	0	23.57
1	47					23.58	(*)	
15	1				0	23.44	(*)	
	1				11	23.41	(*)	
$\pi/4$ - QPSK	3.75			1	0	23.58	(*)	
				1	47	23.58	(*)	
	15			1	0	23.52	(*)	
				1	11	23.47	(*)	
				3	0	22.91	4.42	
				3	6	23.23	4.49	
				6	0	22.31	6.13	
				6	6	22.4	6.1	
12	0			21.7	6.44			
132670	1779.8			$\pi/2$ - BPSK	3.75	1	0	23.53
		1	47			23.53	(*)	
		15	1		0	23.45	(*)	
			1		11	23.47	(*)	
		$\pi/4$ - QPSK	3.75	1	0	23.55	(*)	
				1	47	23.53	(*)	
			15	1	0	23.47	(*)	
				1	11	23.45	(*)	
				3	0	23.43	4.5	
				3	6	23.32	4.53	
				6	0	22.39	6.25	
				6	6	22.38	6.22	
		12	0	21.76	6.81			

(*): Preliminary measurements determined that 3, 6 or 12 tones of 15kHz as the worst case. The results in the next tables shows the results for this configuration.

(**): Average power measurement in Sample 01.

(***): Average power measurement in Sample 02.

NBLoT. BAND 85.

Ch	Freq. (MHz)	Modulation	BW (kHz)	Num. tone	Offset Tone	Average Power (dBm)	PAPR (dB)
134004	698.2	$\pi/2$ - BPSK	3.75	1	0	22.36	(*)
				1	47	22.34	(*)
			15	1	0	22.81	(*)
				1	11	22.8	(*)
		$\pi/4$ - QPSK	3.75	1	0	22.49	(*)
				1	47	22.48	(*)
			15	1	0	22.78	(*)
				1	11	22.79	(*)
				3	0	22.41	3.61
				3	6	22.94	3.42
				6	0	21.64	4.97
				6	6	21.63	5.03
		12	0	20.66	5.56		
		134092	707	$\pi/2$ - BPSK	3.75	1	0
1	47					22.64	(*)
15	1				0	22.44	(*)
	1				11	22.75	(*)
$\pi/4$ - QPSK	3.75			1	0	22.95	(*)
				1	47	22.73	(*)
	15			1	0	22.75	(*)
				1	11	22.72	(*)
				3	0	22.24	3.84
				3	6	22.79	3.63
				6	0	21.55	5.19
				6	6	21.57	5.06
12	0			20.58	5.83		
134180	715.8			$\pi/2$ - BPSK	3.75	1	0
		1	47			22.65	(*)
		15	1		0	22.68	(*)
			1		11	22.69	(*)
		$\pi/4$ - QPSK	3.75	1	0	22.75	(*)
				1	47	22.76	(*)
			15	1	0	22.68	(*)
				1	11	22.61	(*)
				3	0	22.11	4.04
				3	6	22.64	3.85
				6	0	21.44	5.4
				6	6	21.47	5.32
		12	0	20.5	6.27		

(*): Preliminary measurements determined that 3, 6 or 12 tones of 15kHz as the worst case. The results in the next tables shows the results for this configuration.

NBLoT BAND 4.

Channel	Measured maximum average power (dBm) at antenna port	Maximum declared antenna gain (dBi)	Maximum equivalent isotropically radiated power (E.I.R.P.) (dBm)	Maximum effective radiated power E.R.P. (dBm)
Lowest	22.54	2.15	24.69	22.54
Middle	22.57	2.15	24.72	22.57
Highest	22.37	2.15	24.52	22.37
Measurement uncertainty (dB)	<±0.941			

NBLoT BAND 12.

Channel	Measured maximum average power (dBm) at antenna port	Maximum declared antenna gain (dBi)	Maximum equivalent isotropically radiated power (E.I.R.P.) (dBm)	Maximum effective radiated power E.R.P. (dBm)
Lowest	23.27	2.15	25.42	23.27
Middle	23.21	2.15	25.36	23.21
Highest	23.10	2.15	25.25	23.10
Measurement uncertainty (dB)	<±0.941			

NBLoT BAND 13.

Channel	Measured maximum average power (dBm) at antenna port	Maximum declared antenna gain (dBi)	Maximum equivalent isotropically radiated power (E.I.R.P.) (dBm)	Maximum effective radiated power E.R.P. (dBm)
Lowest	22.88	2.15	25.03	22.88
Middle	22.77	2.15	24.92	22.77
Highest	22.80	2.15	24.95	22.80
Measurement uncertainty (dB)	<±0.941			

NBLoT BAND 66.

Channel	Measured maximum average power (dBm) at antenna port	Maximum declared antenna gain (dBi)	Maximum equivalent isotropically radiated power (E.I.R.P.) (dBm)	Maximum effective radiated power E.R.P. (dBm)
Lowest	23.72	2.15	25.87	23.72
Middle	23.58	2.15	25.73	23.58
Highest	23.55	2.15	25.70	23.55
Measurement uncertainty (dB)	<±0.941			

NB IoT BAND 85.

Channel	Measured maximum average power (dBm) at antenna port	Maximum declared antenna gain (dBi)	Maximum equivalent isotropically radiated power (E.I.R.P.) (dBm)	Maximum effective radiated power E.R.P. (dBm)
Lowest	22.94	2.15	25.09	22.94
Middle	22.95	2.15	25.10	22.95
Highest	22.76	2.15	24.91	22.76
Measurement uncertainty (dB)	<±0.941			

Verdict: PASS

PEAK-TO-AVERAGE POWER RATIO (PAPR).

NB-IoT BAND 4.

Preliminary measurements determined that 12 tones of 15kHz as the worst case. The results in the next tables shows the results for this configuration.

Channel Low:

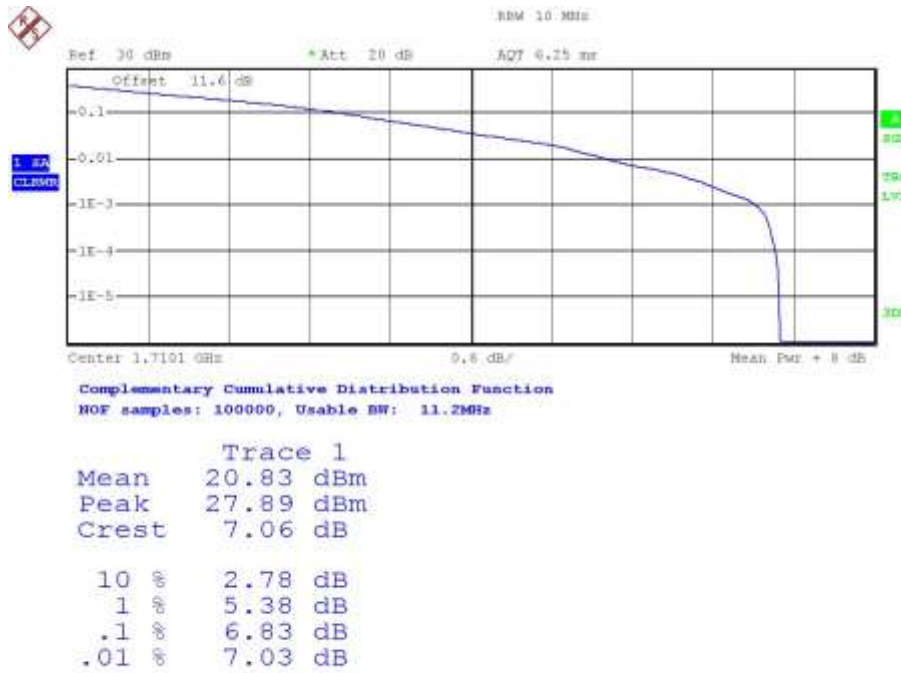

Channel Middle:

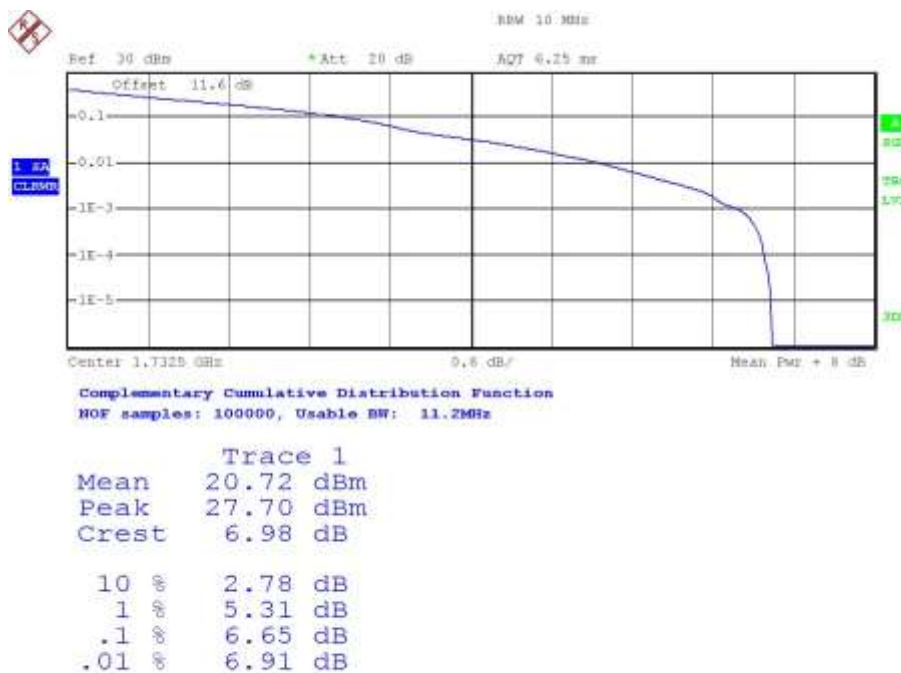

Channel High:

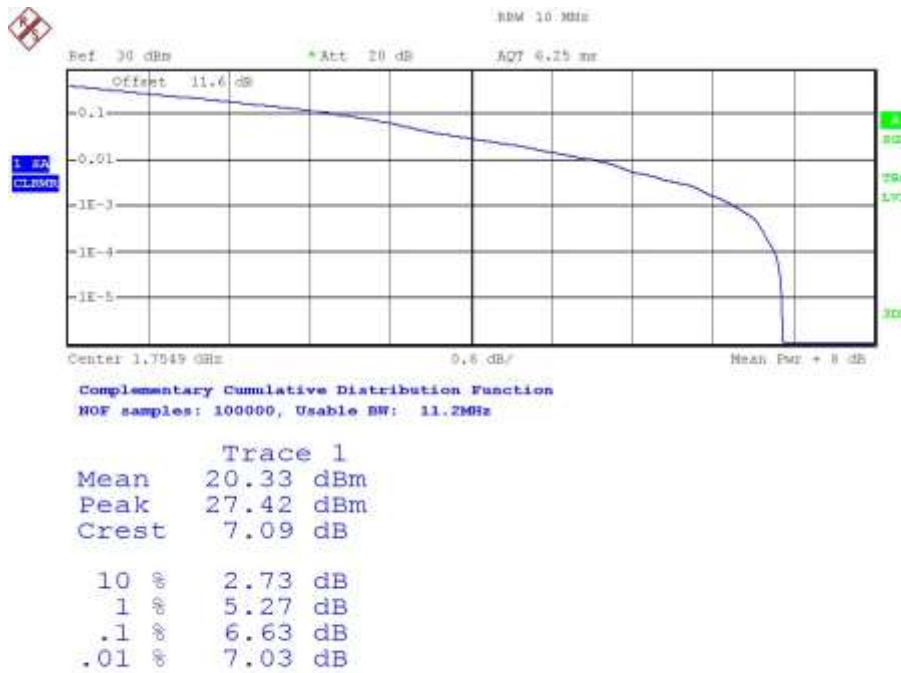

NB-IoT BAND 12.

Preliminary measurements determined that 12 tones of 15kHz as the worst case. The results in the next tables shows the results for this configuration.

Channel Low:

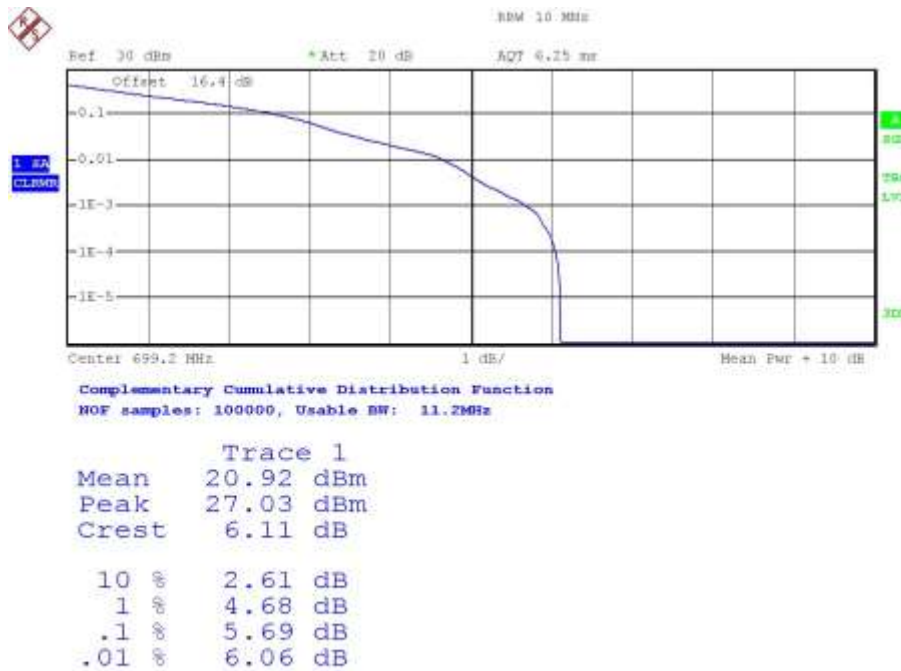

Channel Middle:

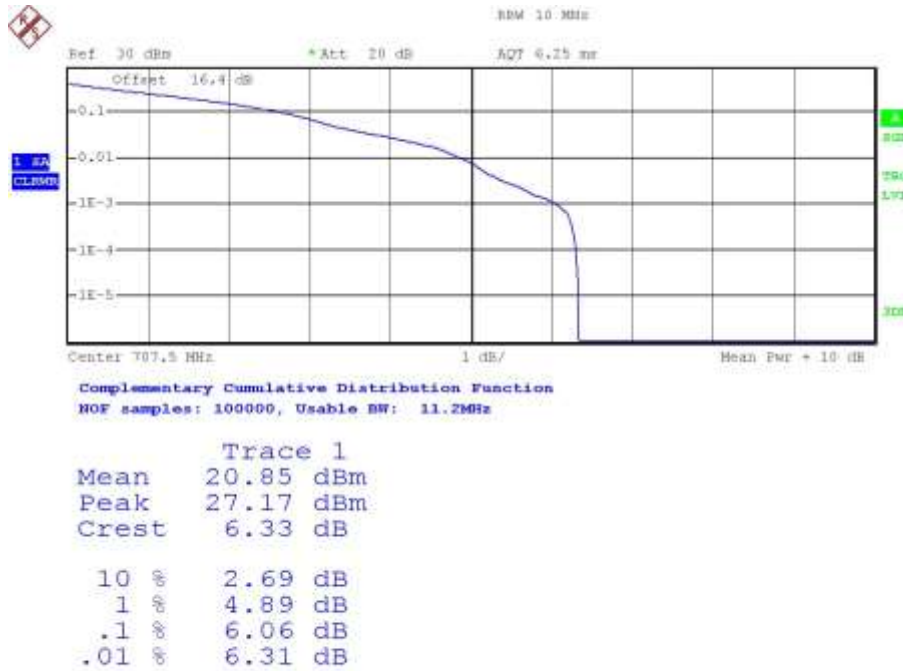

Channel High:

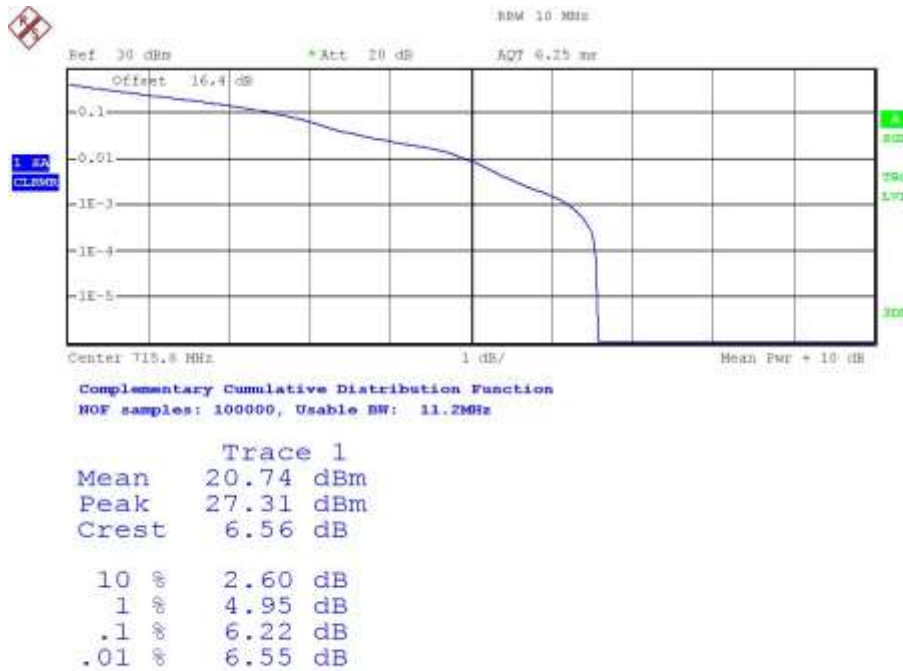

NB IoT BAND 13.

Preliminary measurements determined that 12 tones of 15kHz as the worst case. The results in the next tables shows the results for this configuration.

Channel Low:

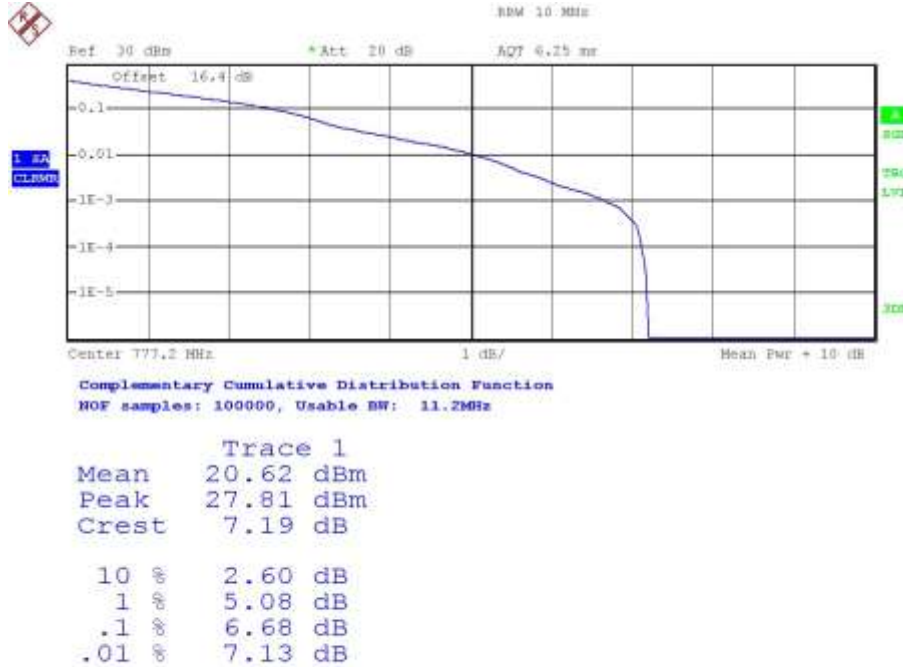

Channel Middle:

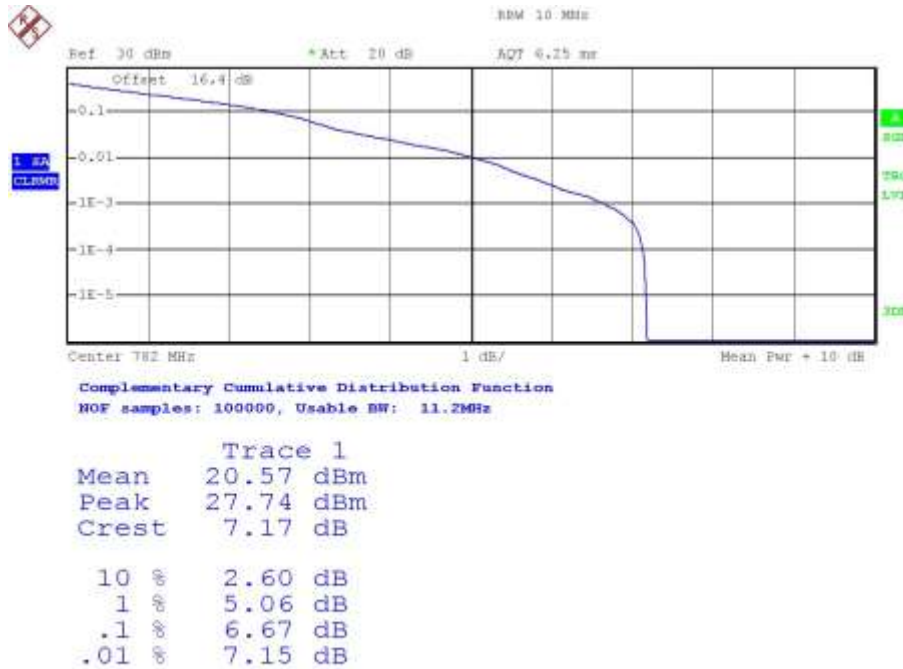

Channel High:

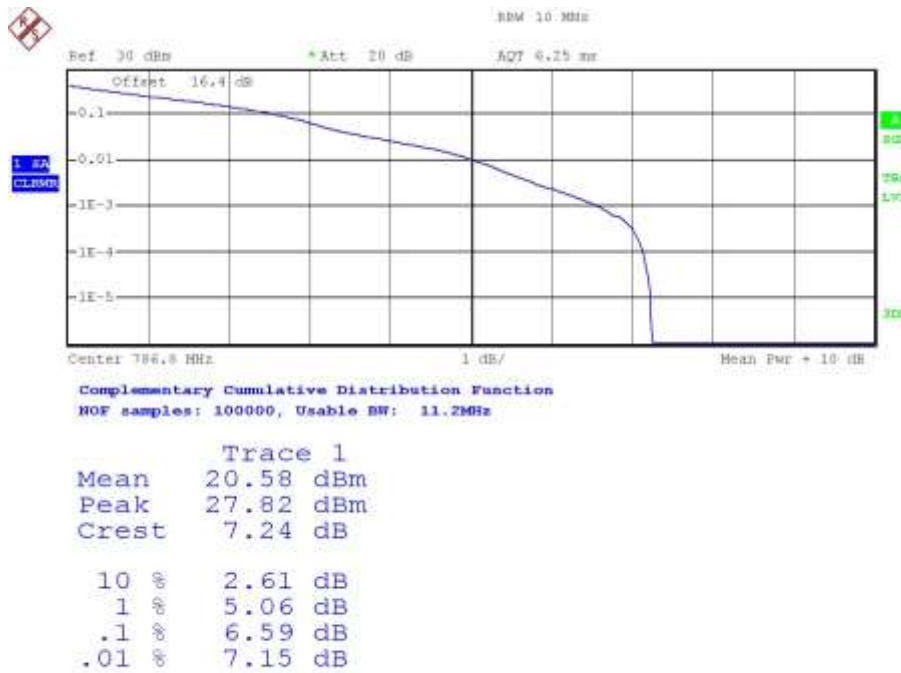

NB-IoT BAND 66.

Preliminary measurements determined that 12 tones of 15kHz as the worst case. The results in the next tables shows the results for this configuration.

Channel Low:

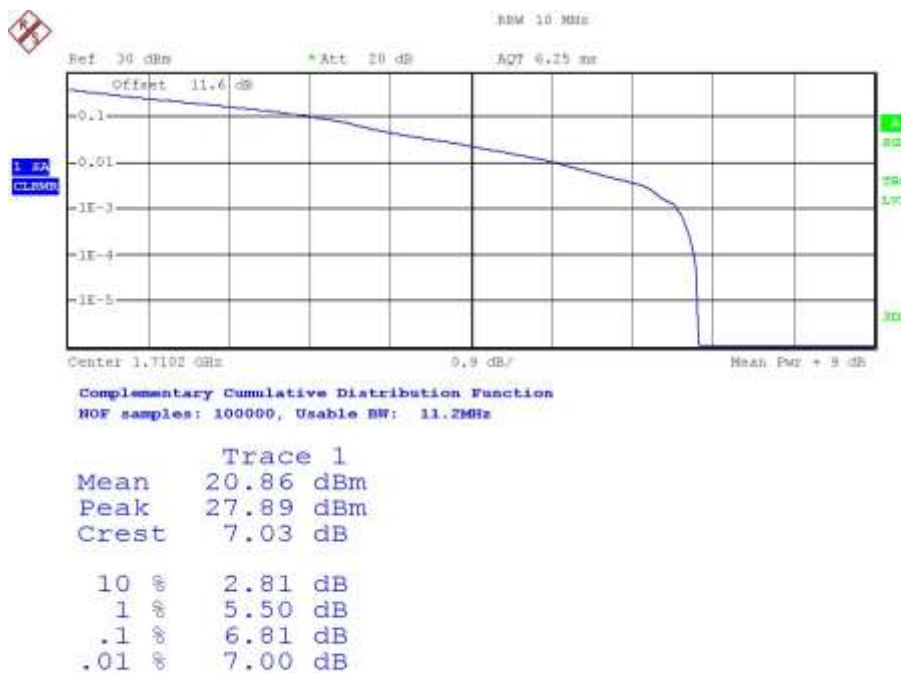

Channel Middle:

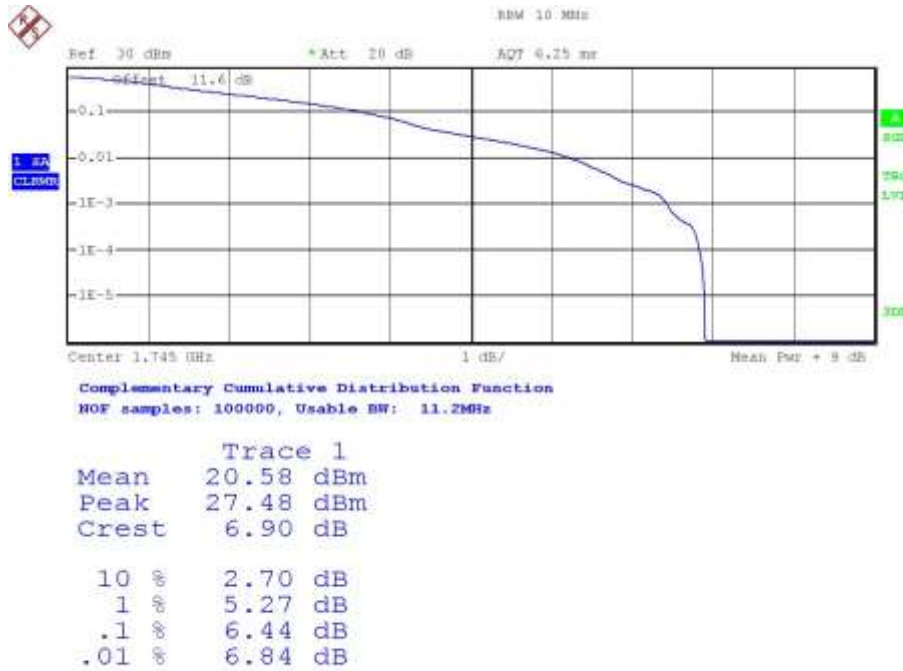

Channel High:

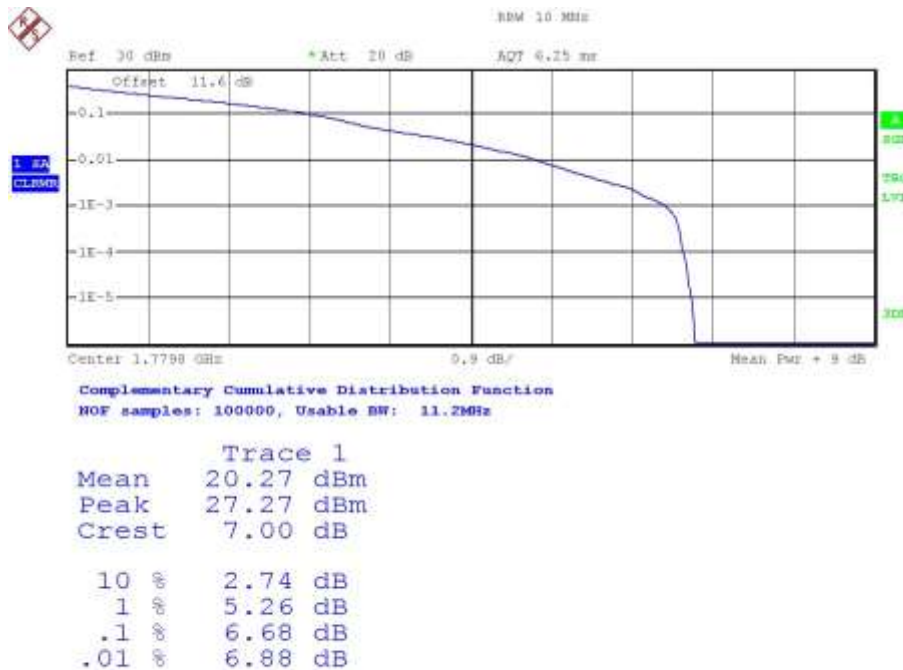

NB IoT BAND 85.

Preliminary measurements determined that 12 tones of 15kHz as the worst case. The results in the next tables shows the results for this configuration.

Channel Low:

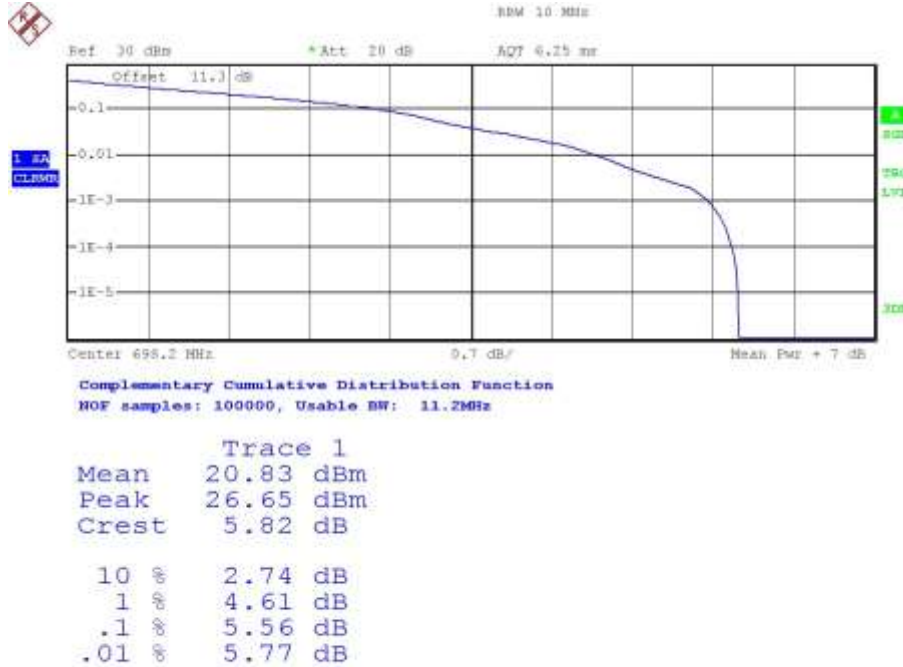

Channel Middle:



Channel High:

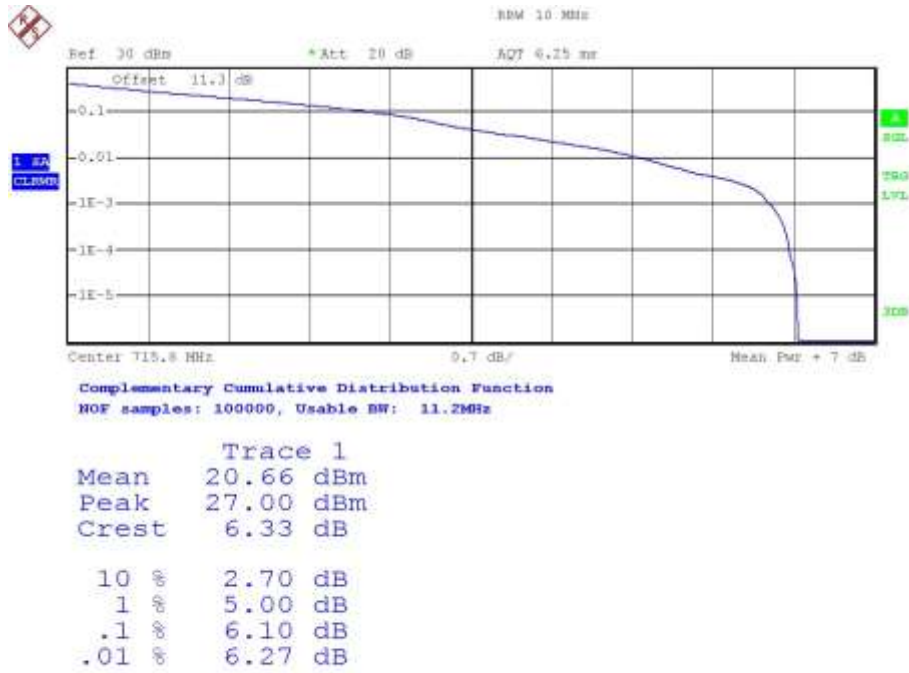

Frequency Stability

SPECIFICATION

FCC §2.1055 and §27.54.

The frequency stability shall be sufficient to ensure that the fundamental emission stays within the authorized frequency block.

RSS-130. Clause 4.5.

The frequency stability shall be sufficient to ensure that the occupied bandwidth remains within each frequency block range when tested at the temperature and supply voltage variations specified in RSS-Gen.

RSS-139 Clause 6.4.

The frequency stability shall be sufficient to ensure that the occupied bandwidth stays within the operating frequency block when tested to the temperature and supply voltage variations specified in RSS-Gen.

METHOD

The frequency tolerance measurements over temperature variations were made over the temperature range of -30°C to $+50^{\circ}\text{C}$. The EUT was placed inside a climatic chamber and the temperature was raised hourly in 10°C steps from -30°C up to $+50^{\circ}\text{C}$.

The supply voltage was varied between 85% and 115% of nominal voltage.

The EUT was set in "Radio Resource Control (RRC) mode" in the middle channel using the Universal Radio Communication tester R&S CMW500 and the maximum frequency error was measured using the built-in calibrated frequency meter.

The worst case NB-IoT mode for conducted power was used for the test.

In order to check that the frequency stability is sufficient such that the fundamental emissions stay within the authorized bands of operation, a reference point is established at the applicable unwanted emissions limit using a RBW equal to the RBW required by the unwanted emissions specification of the applicable regulatory standard. These reference points measured using the lowest and highest channel of operation are identified as fL and fH respectively. The worst-case frequency offset determined in the above methods is added or subtracted from the values of fL and fH to check that the resulting frequencies remain within the band.

The reference point measurements were made at the RF output terminals of the EUT using an attenuator, power splitter and spectrum analyser. The EUT was controlled via the Universal Radio Communication tester R&S CMW500 selecting maximum transmission power.

TEST SETUP

Frequency tolerance.

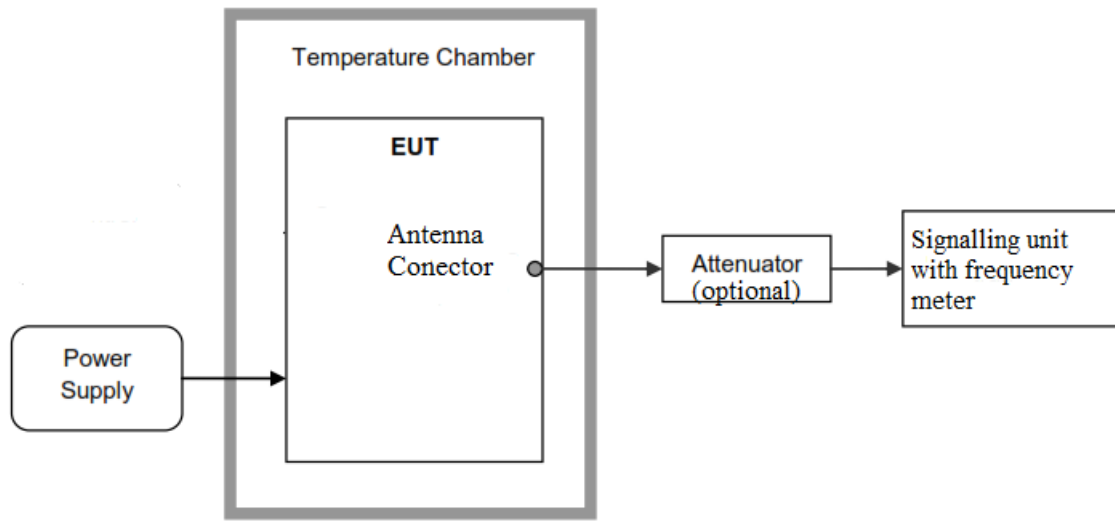

Reference points f_L and f_H .

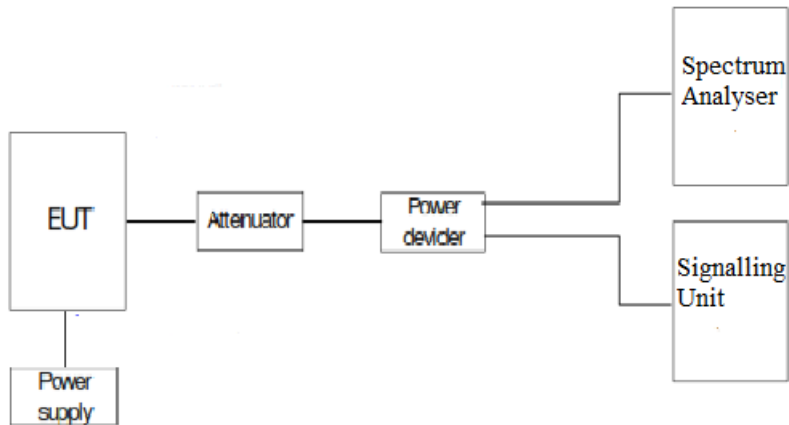

RESULTS

Frequency stability over temperature variations.

NBLoT Band 12 - $\pi/4$ - QPSK modulation. 1 tone 3.75 kHz. Channel: 707.5 MHz.

Temperature (°C)	Frequency Error (Hz)	Frequency Error (ppm)
+50	-1.76	-0.002487633
+40	-6.85	-0.009681979
+30	3.02	0.004268551
+20	-2.89	-0.004084806
+10	1.85	0.002614841
0	-9.33	-0.013187279
-10	-4.96	-0.007010601
-20	-6.81	-0.009625442
-30	1.44	0.002035336

Measurement uncertainty (Hz)	< ± 87
------------------------------	------------

NBLoT Band 13 - $\pi/4$ - QPSK modulation. 1 tone 3.75 kHz. Channel: 782 MHz.

Temperature (°C)	Frequency Error (Hz)	Frequency Error (ppm)
+50	1.65	0.002109974
+40	-1.13	-0.001445013
+30	3.01	0.003849105
+20	-0.76	-0.000971867
+10	0.93	0.001189258
0	2.73	0.003491049
-10	2.13	0.002723785
-20	-5.79	-0.007404092
-30	4.98	0.006368286

Measurement uncertainty (Hz)	< ± 96
------------------------------	------------

NBLoT Band 66 - $\pi/4$ - QPSK modulation. 1 tone 3.75 kHz. Channel: 1745 MHz.

Temperature (°C)	Frequency Error (Hz)	Frequency Error (ppm)
+50	3.33	0.001908309
+40	-2.9	-0.001661891
+30	-2.88	-0.00165043
+20	-5.24	-0.003002865
+10	6.94	0.003977077
0	6.19	0.003547278
-10	-2.68	-0.001535817
-20	2.33	0.001335244
-30	-6.22	-0.00356447

Measurement uncertainty (Hz)	< \pm 208
------------------------------	-------------

NBLoT Band 85 - $\pi/4$ - QPSK modulation. 1 tone 3.75 kHz. Channel: 707 MHz.

Temperature (°C)	Frequency Error (Hz)	Frequency Error (ppm)
+50	-4.63	-0.006548798
+40	-7.07	-0.01
+30	10.81	0.015289958
+20	0.87	0.001230552
+10	5.69	0.008048091
0	11.77	0.016647808
-10	1.56	0.002206506
-20	-2.46	-0.003479491
-30	2.96	0.004186704

Measurement uncertainty (Hz)	< \pm 87
------------------------------	------------

Frequency stability over voltage variations.

NBLoT Band 12

Battery Supply voltage	Voltage (V)	Frequency Error (Hz)	Frequency Error (ppm)
Vmax	4.2	1.96	0.002770318
Vmin	3.2	-4.05	-0.005724382

NBLoT Band 13

Battery Supply voltage	Voltage (V)	Frequency Error (Hz)	Frequency Error (ppm)
Vmax	4.2	-6.37	-0.00814578
Vmin	3.2	-2.43	-0.003107417

NBLoT Band 66

Battery Supply voltage	Voltage (V)	Frequency Error (Hz)	Frequency Error (ppm)
Vmax	4.2	1.68	0.000962751
Vmin	3.2	8.73	0.005002865

NBLoT Band 85

Battery Supply voltage	Voltage (V)	Frequency Error (Hz)	Frequency Error (ppm)
Vmax	4.2	-6.11	-0.00864215
Vmin	3.2	-2.85	-0.004031117

Reference points established at the applicable unwanted emissions limit (worst case):

	NBLoT Band 12
f_L (MHz)	698.937670
f_H (MHz)	715.963417

	NBLoT Band 13
f_L (MHz)	777.048700
f_H (MHz)	786.952633

	NBLoT Band 66
f_L (MHz)	1710.05340
f_H (MHz)	1779.93900

	NBLoT Band 85
f_L (MHz)	698.04290
f_H (MHz)	715.97494

Reference points f_L and f_H with the worst-case frequency offsets added or subtracted:

	NBLoT Band 12
f_L (MHz)	698.937660
f_H (MHz)	715.963420

	NBLoT Band 13
f_L (MHz)	777.048694
f_H (MHz)	786.952637

	NBLoT Band 66
f_L (MHz)	1710.05324
f_H (MHz)	1779.93900

	NBLoT Band 85
f_L (MHz)	698.042892
f_H (MHz)	715.975177

The reference frequency points stay within the authorized blocks.

Verdict: PASS

Modulation Characteristics

SPECIFICATION

FCC §2.1047

RSS-130. Clause 4.2 and RSS-133. Clause 6.2. Equipment certified under this standard shall use digital modulation.

RSS-139 Clause 6.2:

The devices may employ any type of modulation techniques. The type of modulation used must be reported.

RSS-199 Clause 4.1:

Equipment certified under this standard shall employ digital modulation.

METHOD

For NB-IoT the EUT operates with $\pi/2$ - BPSK and $\pi/4$ - QPSK modulation modes in which the information is digitised and coded into a bit stream.

TEST SETUP

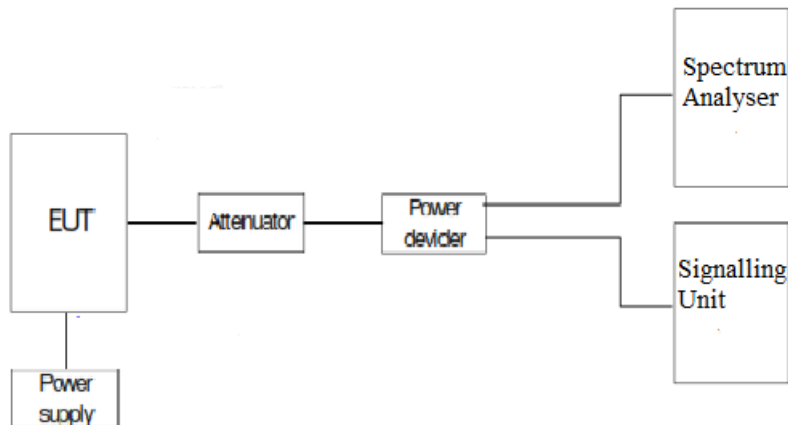

RESULTS

The following plot shows the modulation schemes in the EUT.

NB-IoT MODULATION (Band 12). $\pi/2$ - BPSK.

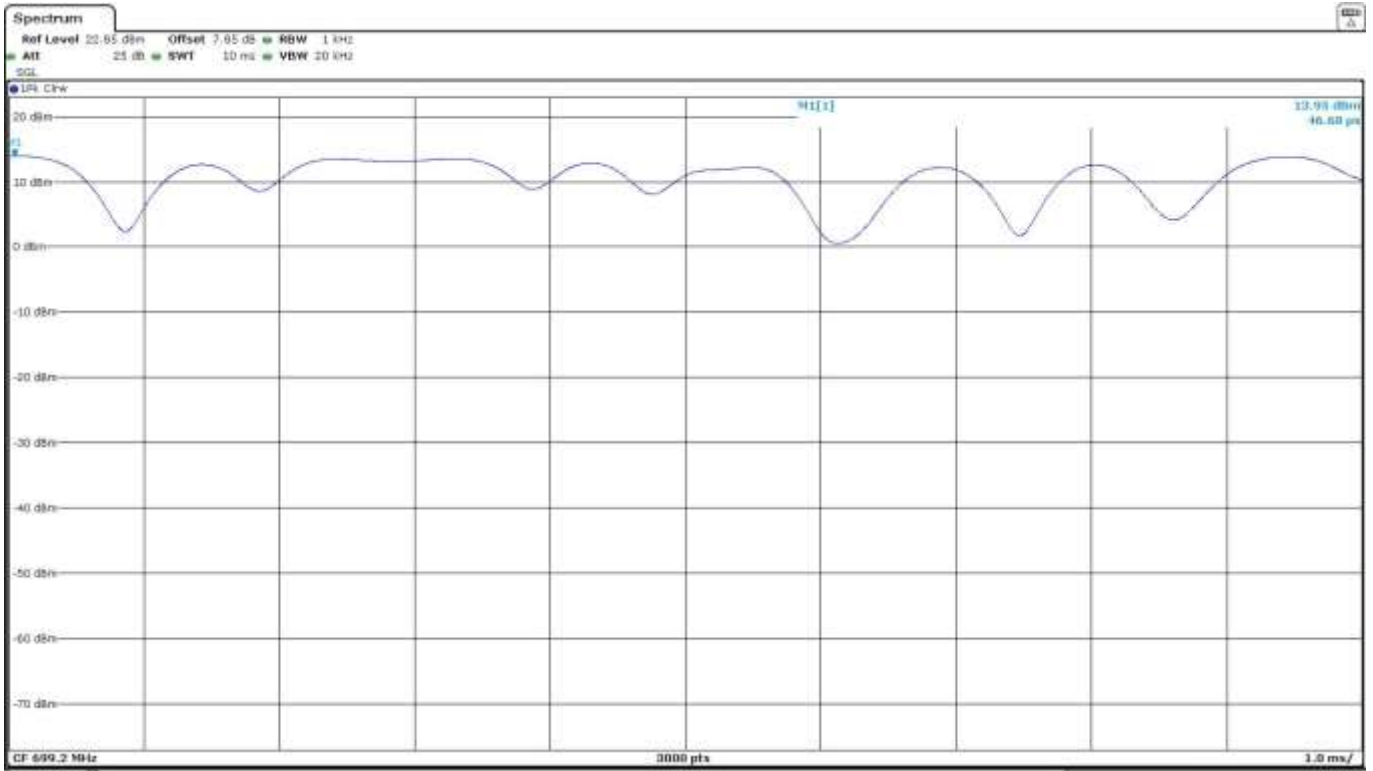

NB-IoT MODULATION (Band 12). $\pi/4$ - QPSK.

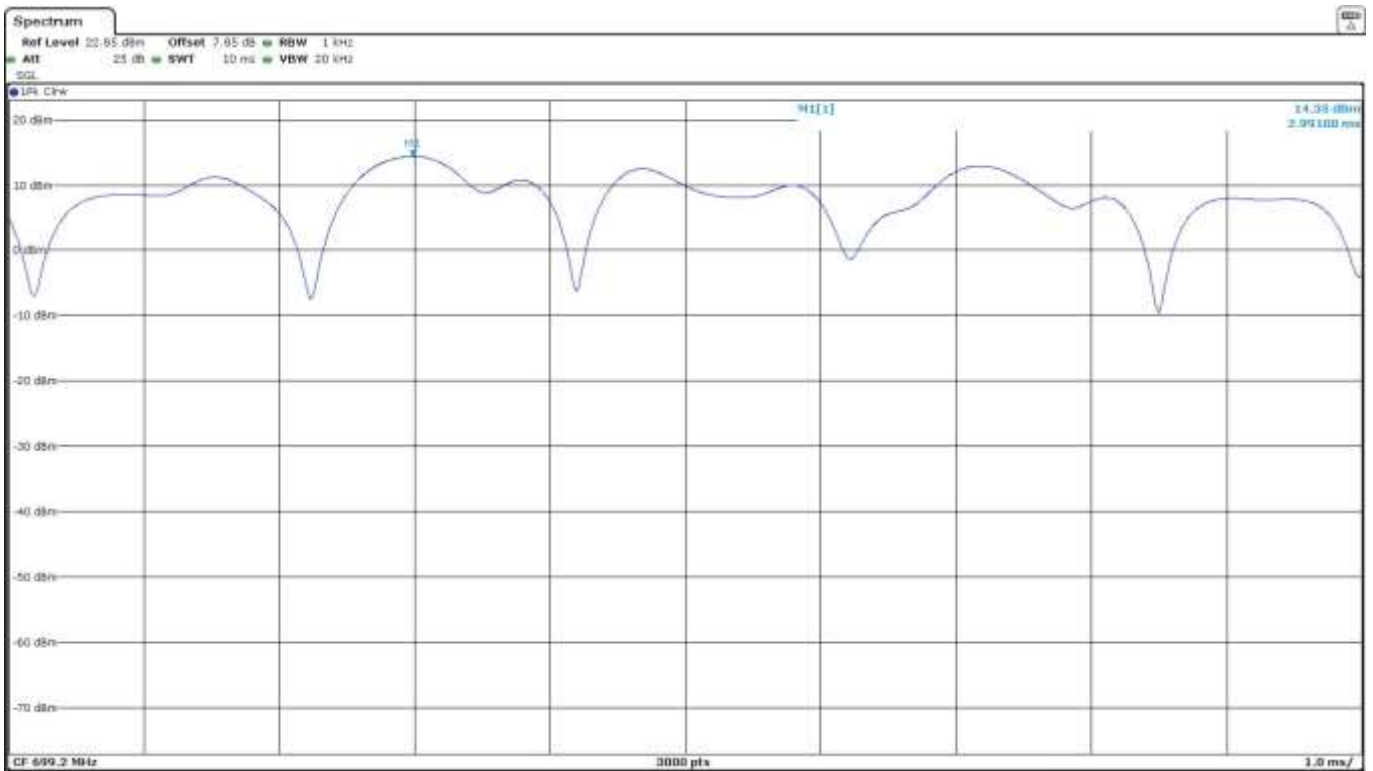

NB-IoT MODULATION (Band 13). $\pi/2$ - BPSK.

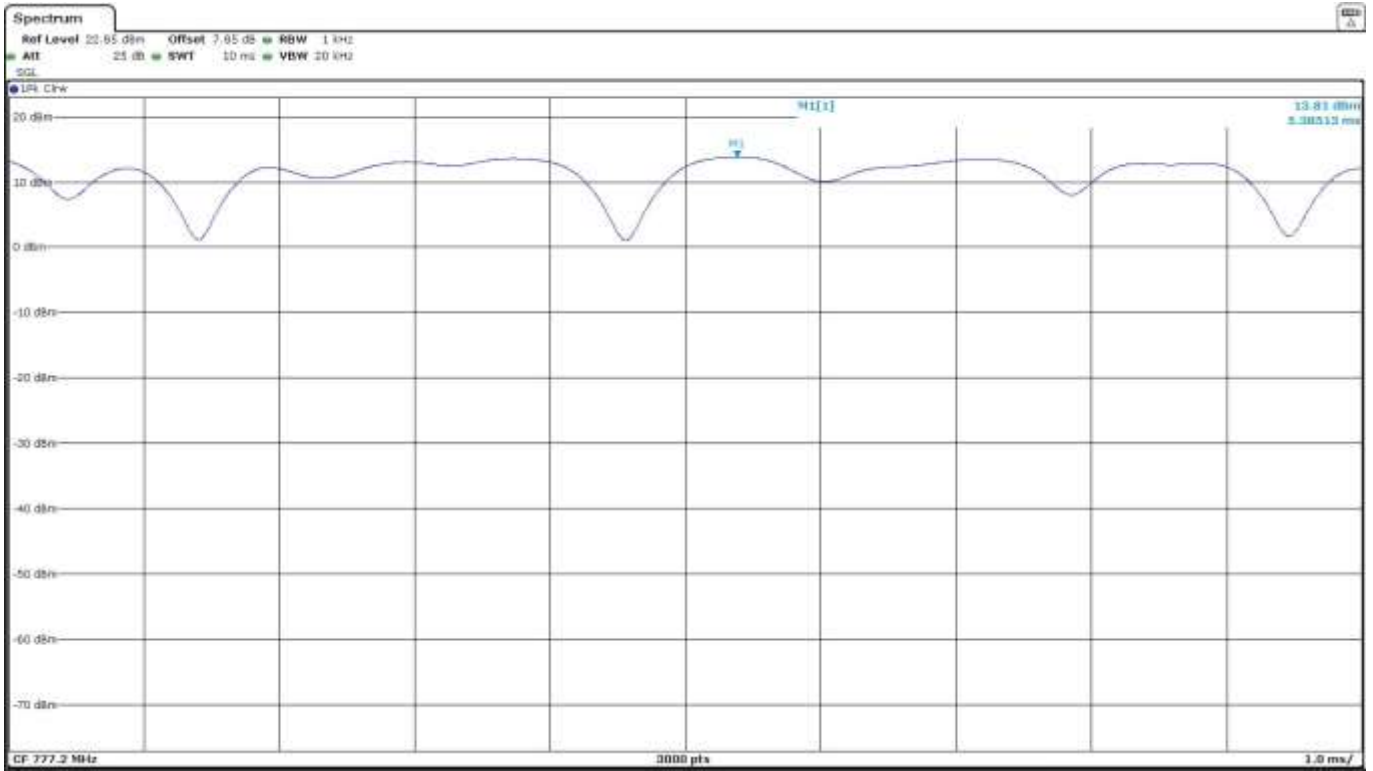

NB-IoT MODULATION (Band 13). $\pi/4$ - QPSK.

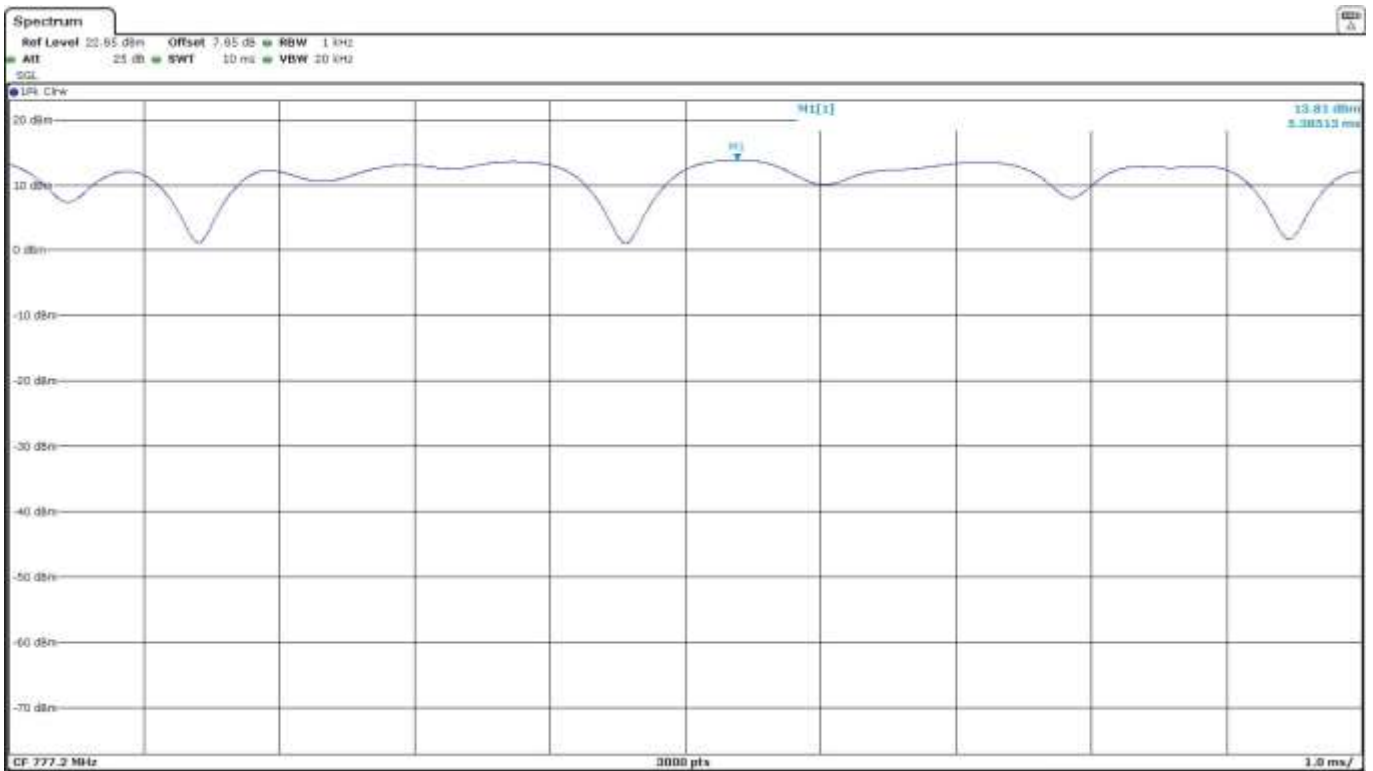

NB-IoT MODULATION (Band 66). $\pi/2$ - BPSK.

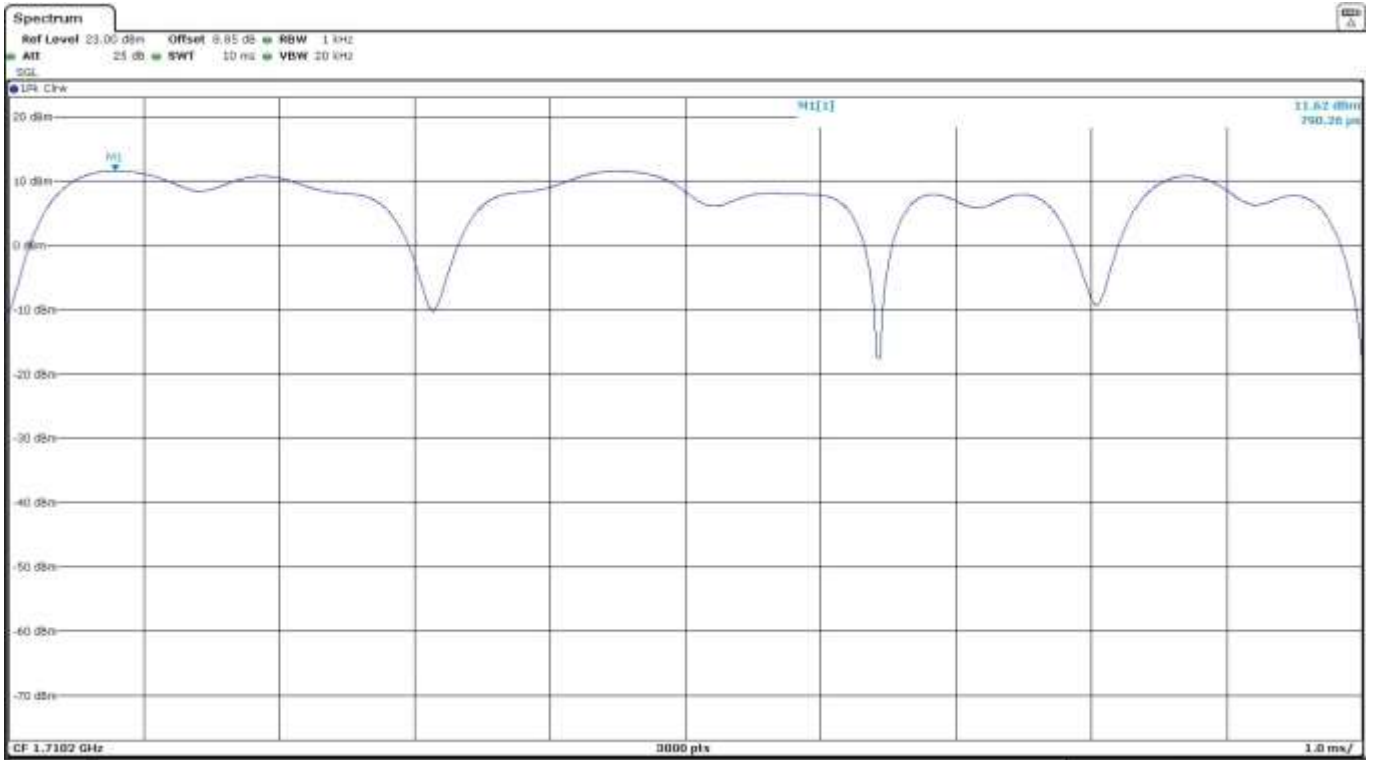

NB-IoT MODULATION (Band 66). $\pi/4$ - QPSK.

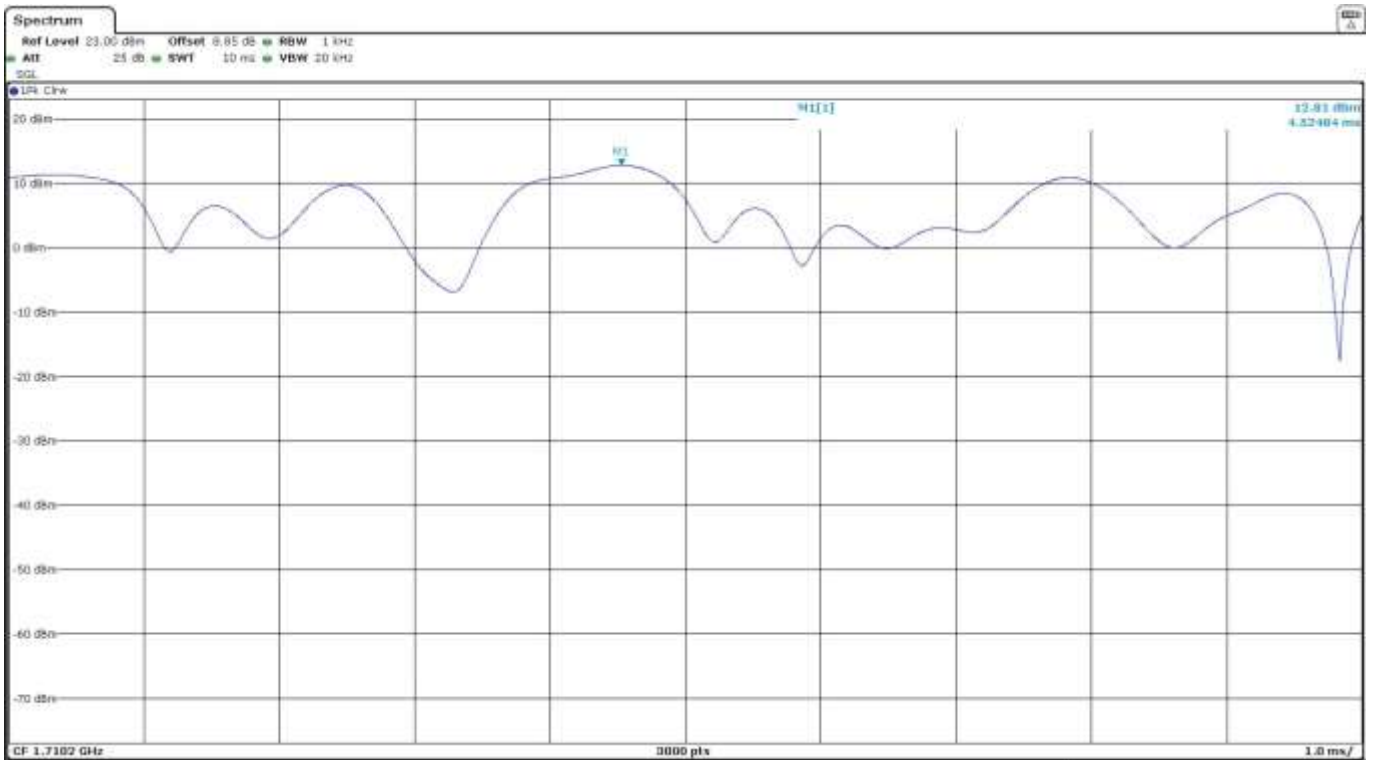

NB-IoT MODULATION (Band 85). $\pi/2$ - BPSK.

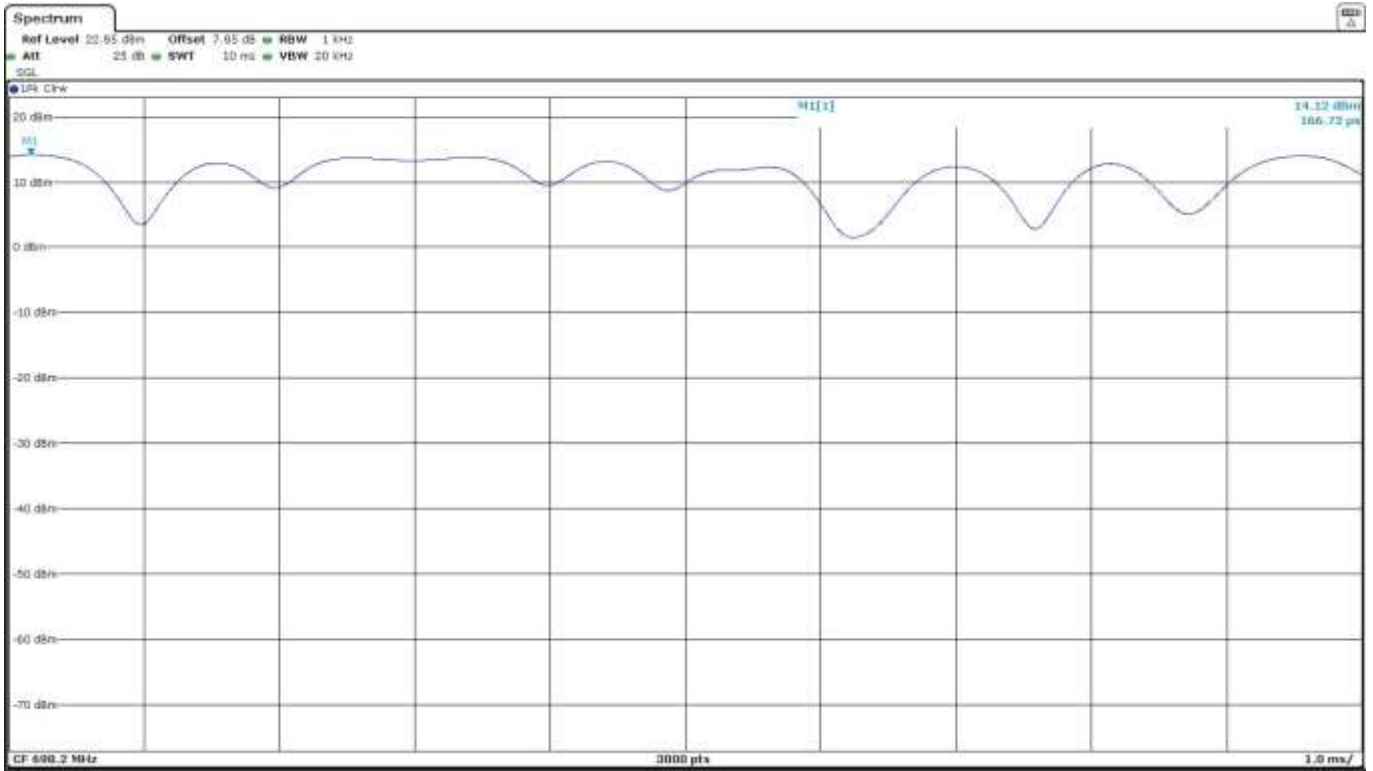

NB-IoT MODULATION (Band 85). $\pi/4$ - QPSK.

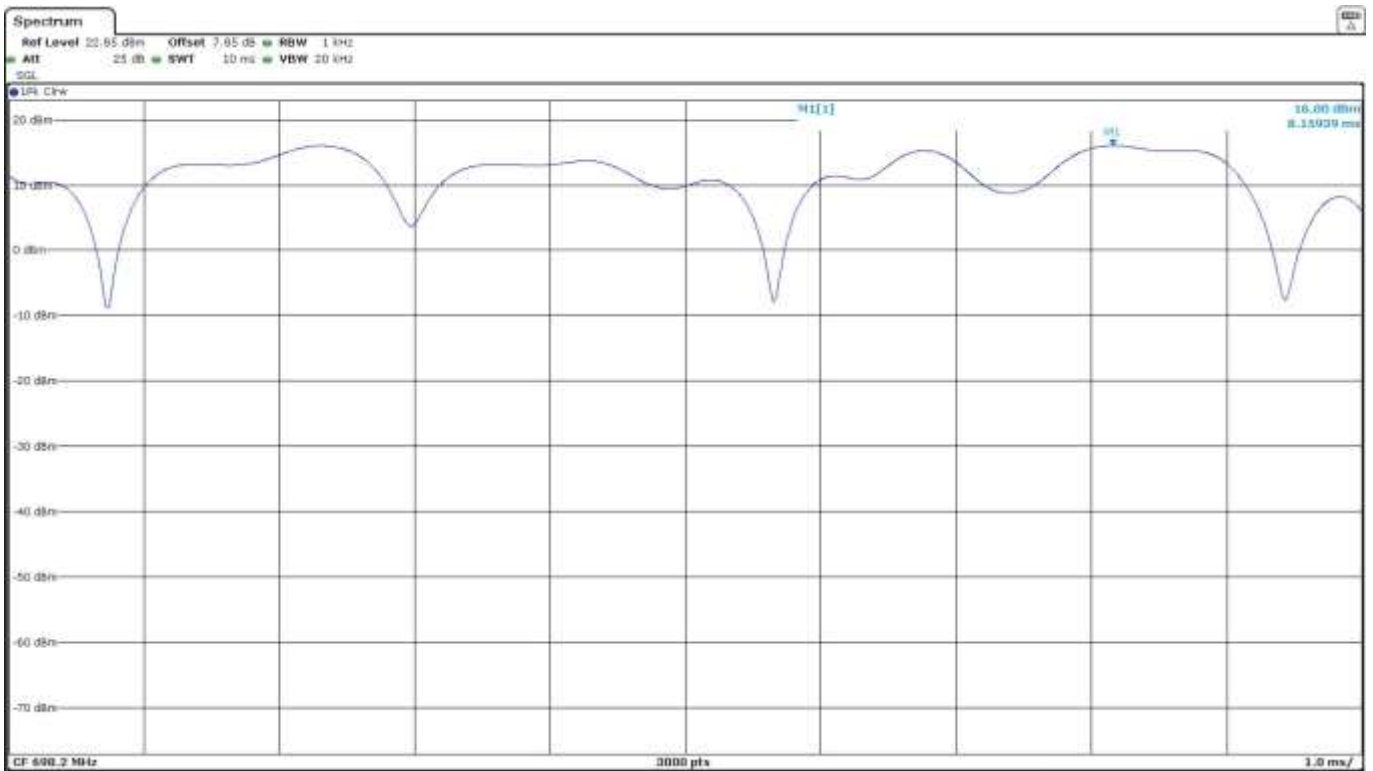

Occupied Bandwidth

SPECIFICATION

§2.1049

METHOD

The occupied bandwidth measurement was performed at the output terminals of the EUT using an attenuator, power splitter and spectrum analyser. The EUT was controlled via the Universal Radio Communication tester R&S CMW500 selecting maximum transmission power of the EUT and different modes of modulation. The 99% occupied bandwidth and the -26 dBc bandwidth were measured directly using the built-in bandwidth measuring option of spectrum analyser.

TEST SETUP

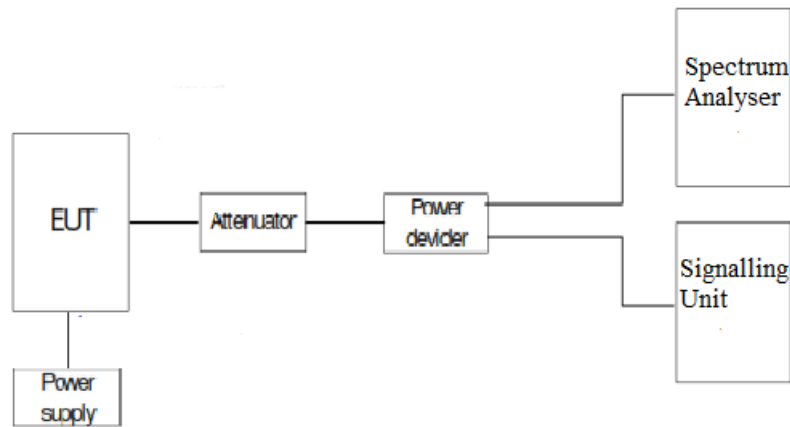

RESULTS (see next plots)

NB-IoT BAND 12.

Tone 3.75 kHz. $\pi/2$ - BPSK MODULATION

Channel	Lowest	Middle	Highest
99% Occupied bandwidth (kHz)	37.433	37.600	37.667
-26 dBc bandwidth (kHz)	34.801	34.803	34.868
Measurement uncertainty (kHz)	< ± 0.13		

Tone 3.75 kHz. $\pi/4$ - QPSK MODULATION

Channel	Lowest	Middle	Highest
99% Occupied bandwidth (kHz)	37.967	37.867	38.033
-26 dBc bandwidth (kHz)	36.978	39.277	36.968
Measurement uncertainty (kHz)	< ± 0.13		

Tone 15 kHz. $\pi/2$ - BPSK MODULATION

Channel	Lowest	Middle	Highest
99% Occupied bandwidth (kHz)	73.333	72.933	73.200
-26 dBc bandwidth (kHz)	89.057	88.924	92.168
Measurement uncertainty (kHz)	< \pm 0.27		

12 Tones 15 kHz. $\pi/4$ - QPSK MODULATION

Channel	Lowest	Middle	Highest
99% Occupied bandwidth (kHz)	190.133	189.867	190.533
-26 dBc bandwidth (kHz)	254.981	255.119	266.176
Measurement uncertainty (kHz)	< \pm 0.12		

NB-IoT BAND 13.

Tone 3.75 kHz. $\pi/2$ - BPSK MODULATION

Channel	Lowest	Middle	Highest
99% Occupied bandwidth (kHz)	37.767	37.833	37.533
-26 dBc bandwidth (kHz)	34.868	34.870	34.830
Measurement uncertainty (kHz)	< \pm 0.13		

Tone 3.75 kHz. $\pi/4$ - QPSK MODULATION

Channel	Lowest	Middle	Highest
99% Occupied bandwidth (kHz)	38.167	38.100	38.267
-26 dBc bandwidth (kHz)	37.031	36.968	39.297
Measurement uncertainty (kHz)	< \pm 0.13		

Tone 15 kHz. $\pi/2$ - BPSK MODULATION

Channel	Lowest	Middle	Highest
99% Occupied bandwidth (kHz)	73.467	73.200	73.467
-26 dBc bandwidth (kHz)	92.368	92.306	92.221
Measurement uncertainty (kHz)	< \pm 0.27		

12 Tones 15 kHz. $\pi/4$ - QPSK MODULATION

Channel	Lowest	Middle	Highest
99% Occupied bandwidth (kHz)	191.467	189.333	190.533
-26 dBc bandwidth (kHz)	266.096	267.800	256.016
Measurement uncertainty (kHz)	< \pm 0.65		

NBLoT BAND 66.

Tone 3.75 kHz. $\pi/2$ - BPSK MODULATION

Channel	Lowest	Middle	Highest
99% Occupied bandwidth (kHz)	45.600	45.333	45.933
-26 dBc bandwidth (kHz)	40.300	40.933	41.200
Measurement uncertainty (kHz)	< \pm 0.13		

Tone 3.75 kHz. $\pi/4$ - QPSK MODULATION

Channel	Lowest	Middle	Highest
99% Occupied bandwidth (kHz)	47.333	47.600	48.000
-26 dBc bandwidth (kHz)	41.700	41.800	41.600
Measurement uncertainty (kHz)	< \pm 0.13		

Tone 15 kHz. $\pi/2$ - BPSK MODULATION

Channel	Lowest	Middle	Highest
99% Occupied bandwidth (kHz)	75.083	75.333	75.666
-26 dBc bandwidth (kHz)	92.250	89.333	89.867
Measurement uncertainty (kHz)	< \pm 0.27		

12 Tones 15 kHz. $\pi/4$ - QPSK MODULATION

Channel	Lowest	Middle	Highest
99% Occupied bandwidth (kHz)	192.800	192.800	193.067
-26 dBc bandwidth (kHz)	277.050	268.800	268.400
Measurement uncertainty (kHz)	< \pm 0.65		

NBLoT BAND 85.

Tone 3.75 kHz. $\pi/2$ - BPSK MODULATION

Channel	Lowest	Middle	Highest
99% Occupied bandwidth (kHz)	37.600	34.233	37.733
-26 dBc bandwidth (kHz)	34.833	37.433	34.800
Measurement uncertainty (kHz)	< \pm 0.13		

Tone 3.75 kHz. $\pi/4$ - QPSK MODULATION

Channel	Lowest	Middle	Highest
99% Occupied bandwidth (kHz)	37.900	37.933	38.133
-26 dBc bandwidth (kHz)	36.933	39.233	36.933
Measurement uncertainty (kHz)	< \pm 0.13		

Tone 15 kHz. $\pi/2$ - BPSK MODULATION

Channel	Lowest	Middle	Highest
99% Occupied bandwidth (kHz)	73.667	73.667	73.500
-26 dBc bandwidth (kHz)	92.192	92.083	92.000
Measurement uncertainty (kHz)	< \pm 0.27		

12 Tones 15 kHz. $\pi/4$ - QPSK MODULATION

Channel	Lowest	Middle	Highest
99% Occupied bandwidth (kHz)	190.267	189.733	190.133
-26 dBc bandwidth (kHz)	254.800	254.800	254.800
Measurement uncertainty (kHz)	< \pm 0.65		

NB IoT BAND 12.

Tone 3.75 kHz. $\pi/2$ - BPSK MODULATION

Lowest Channel

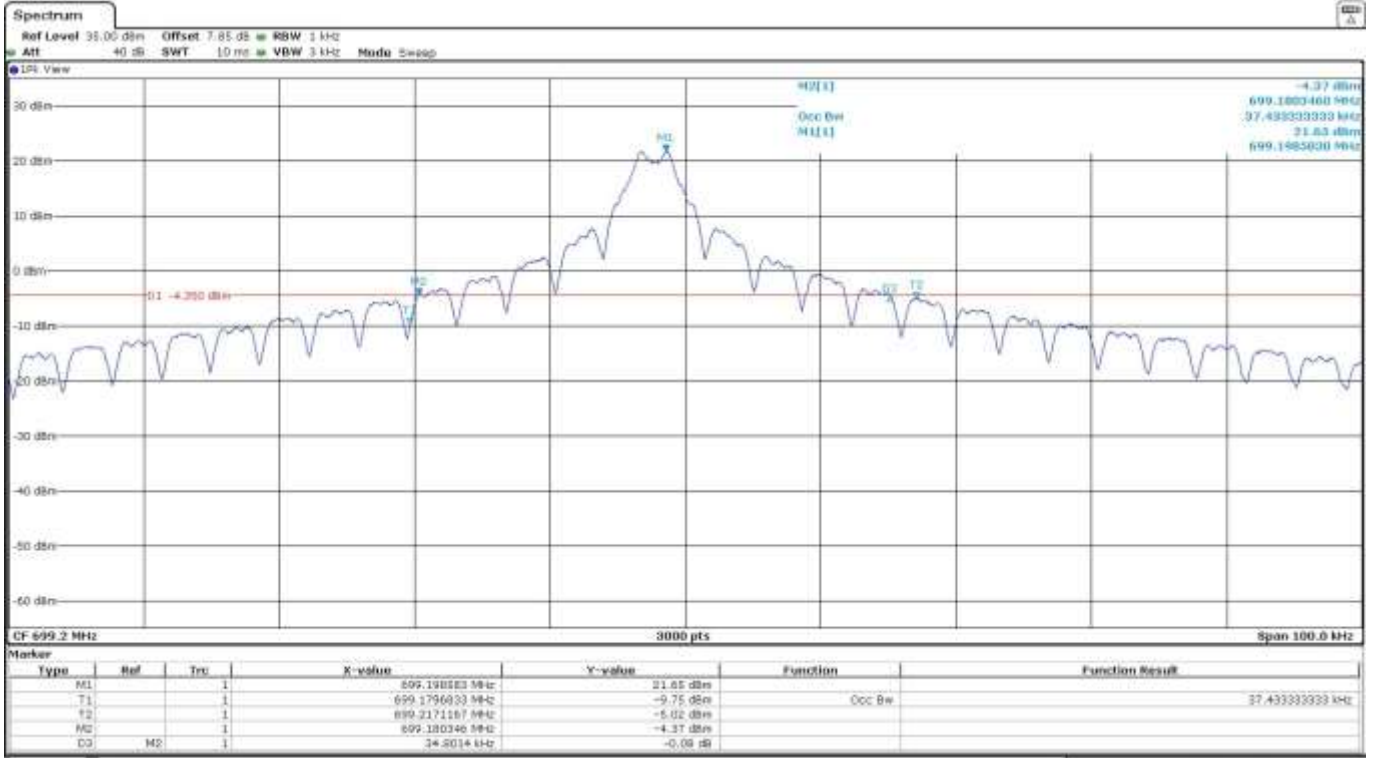

Middle Channel

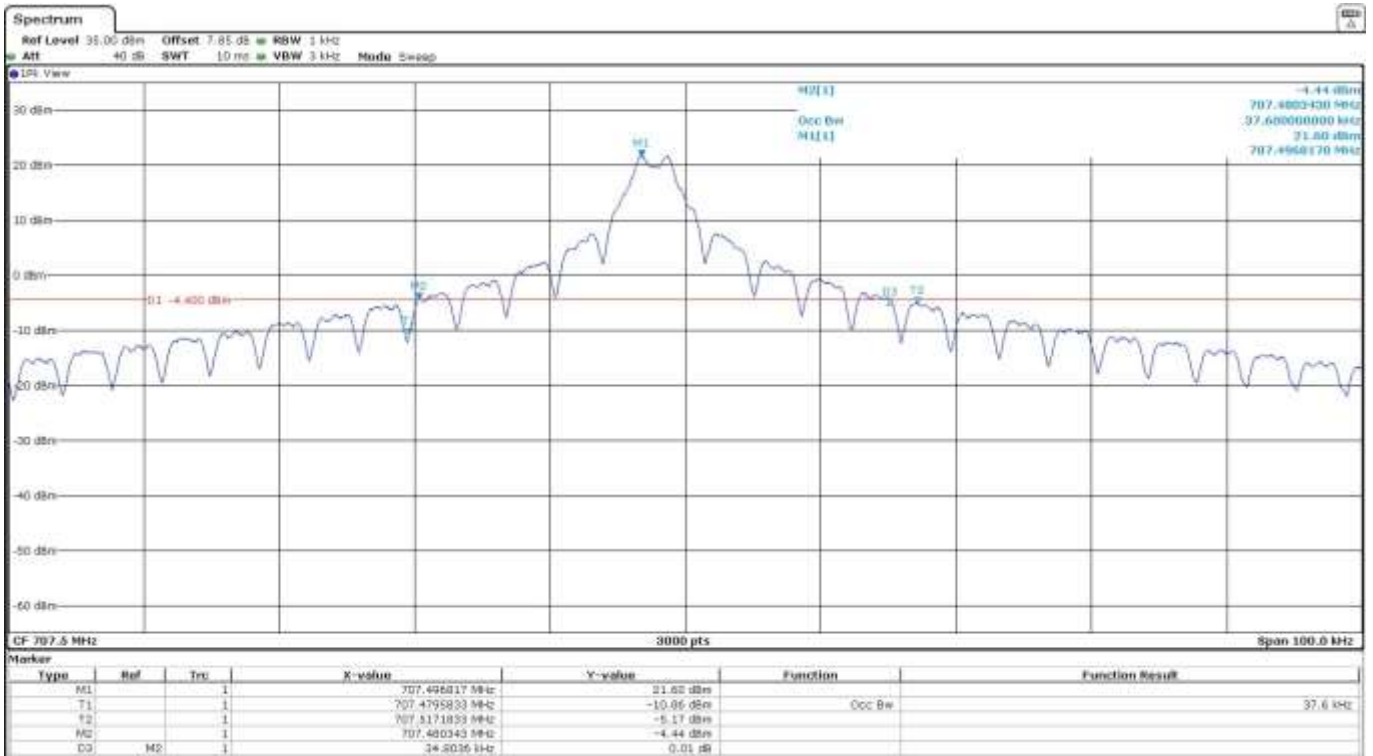

Highest Channel

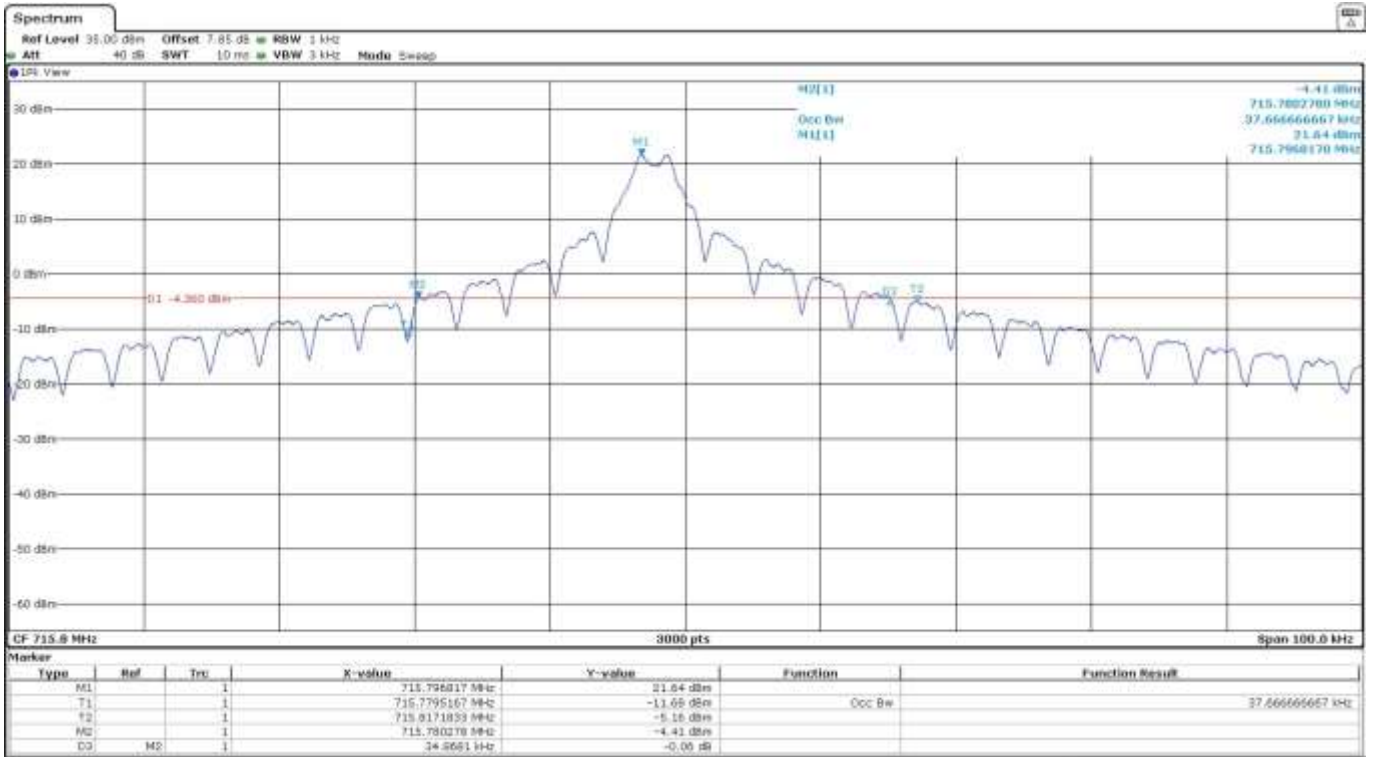

Tone 3.75 kHz. $\pi/4$ - QPSK MODULATION

Lowest Channel

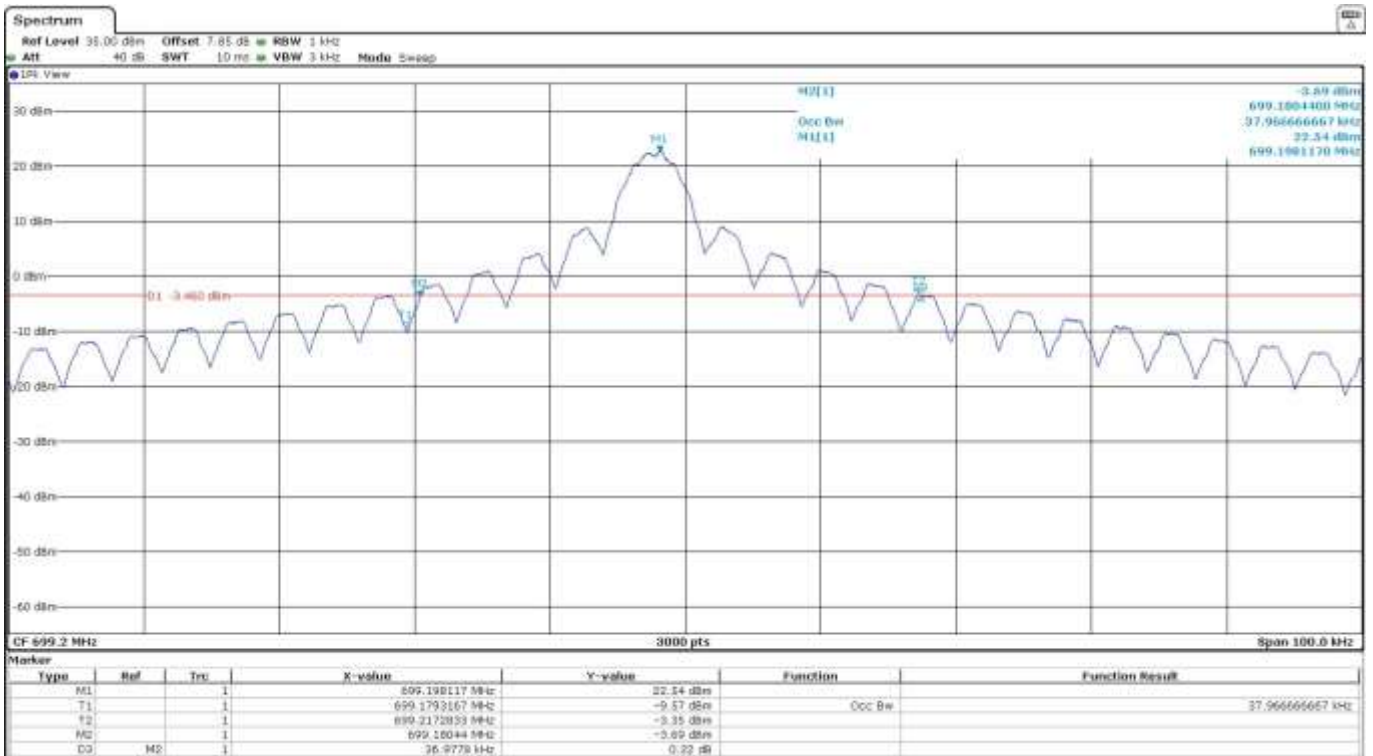

Middle Channel

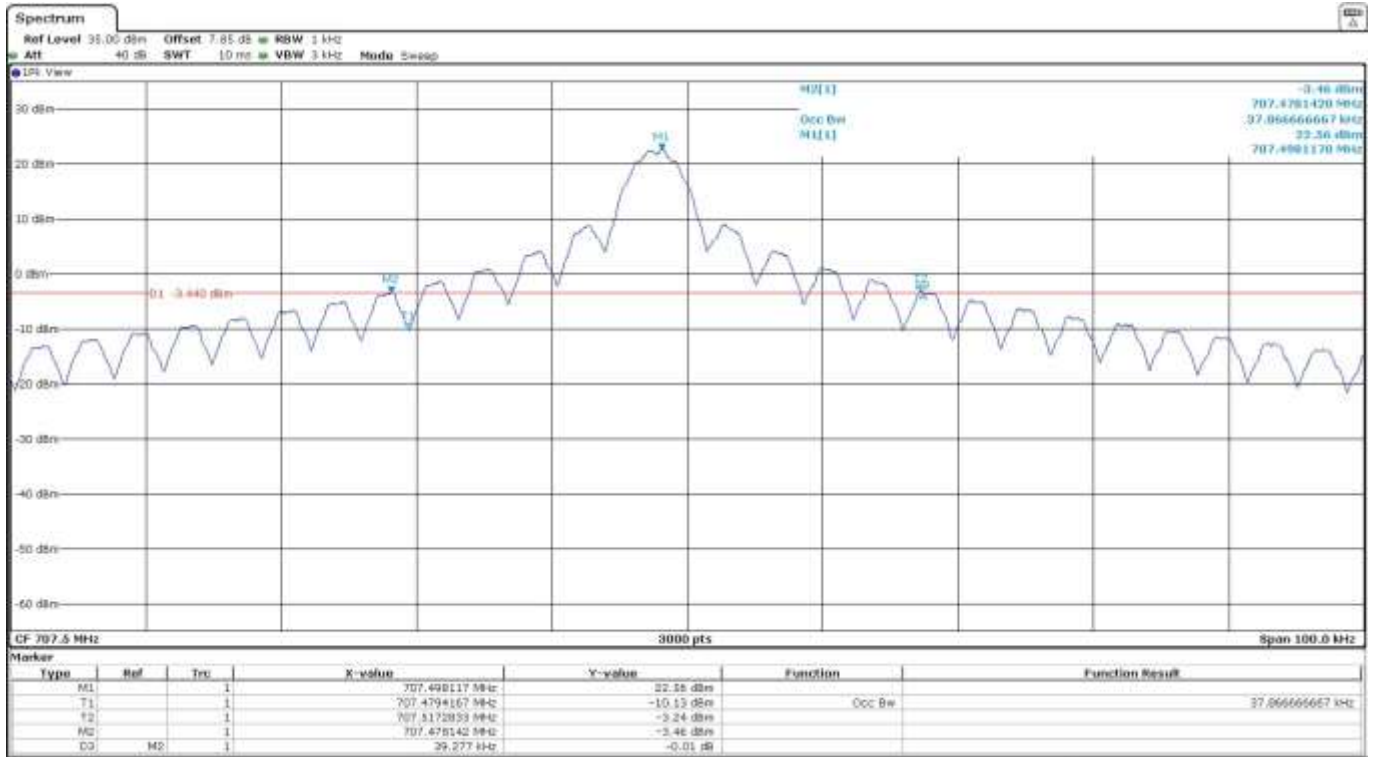

Highest Channel

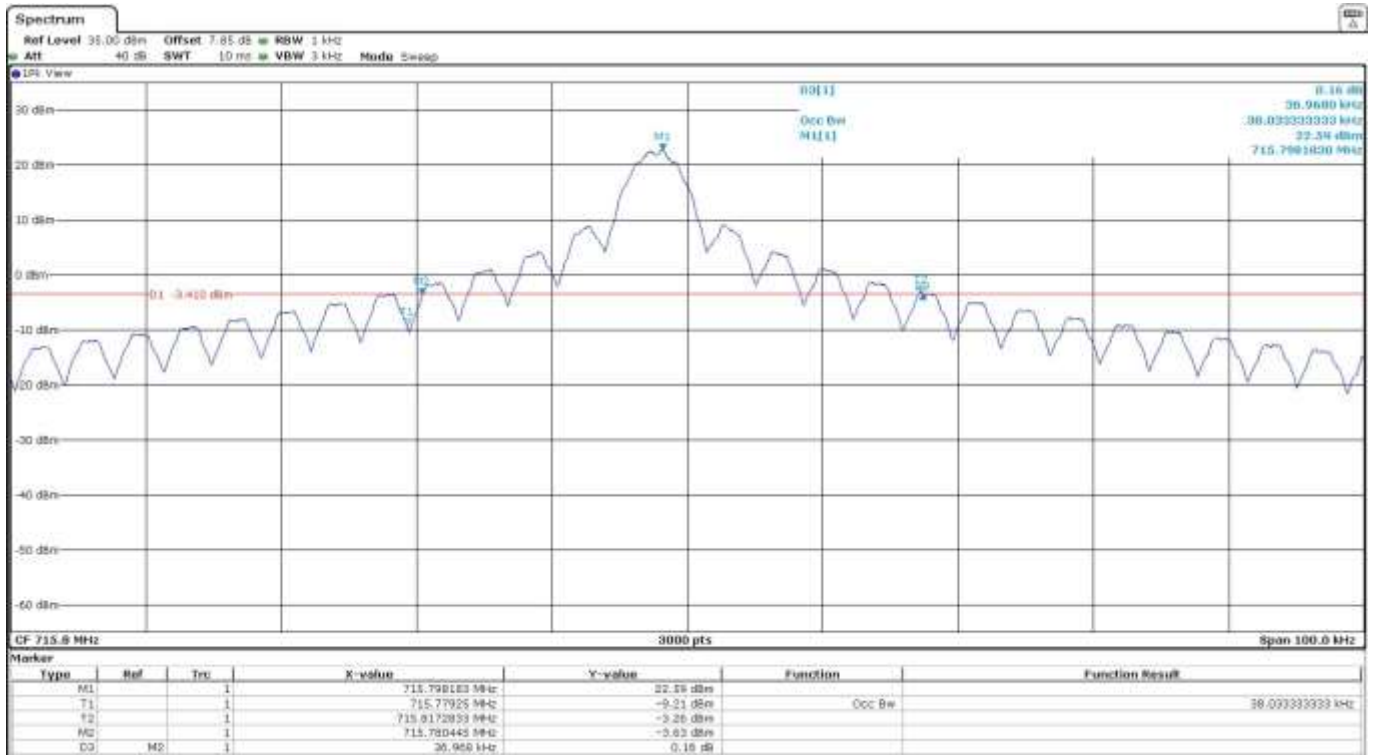

Tone 15 kHz. $\pi/2$ - BPSK MODULATION

Lowest Channel

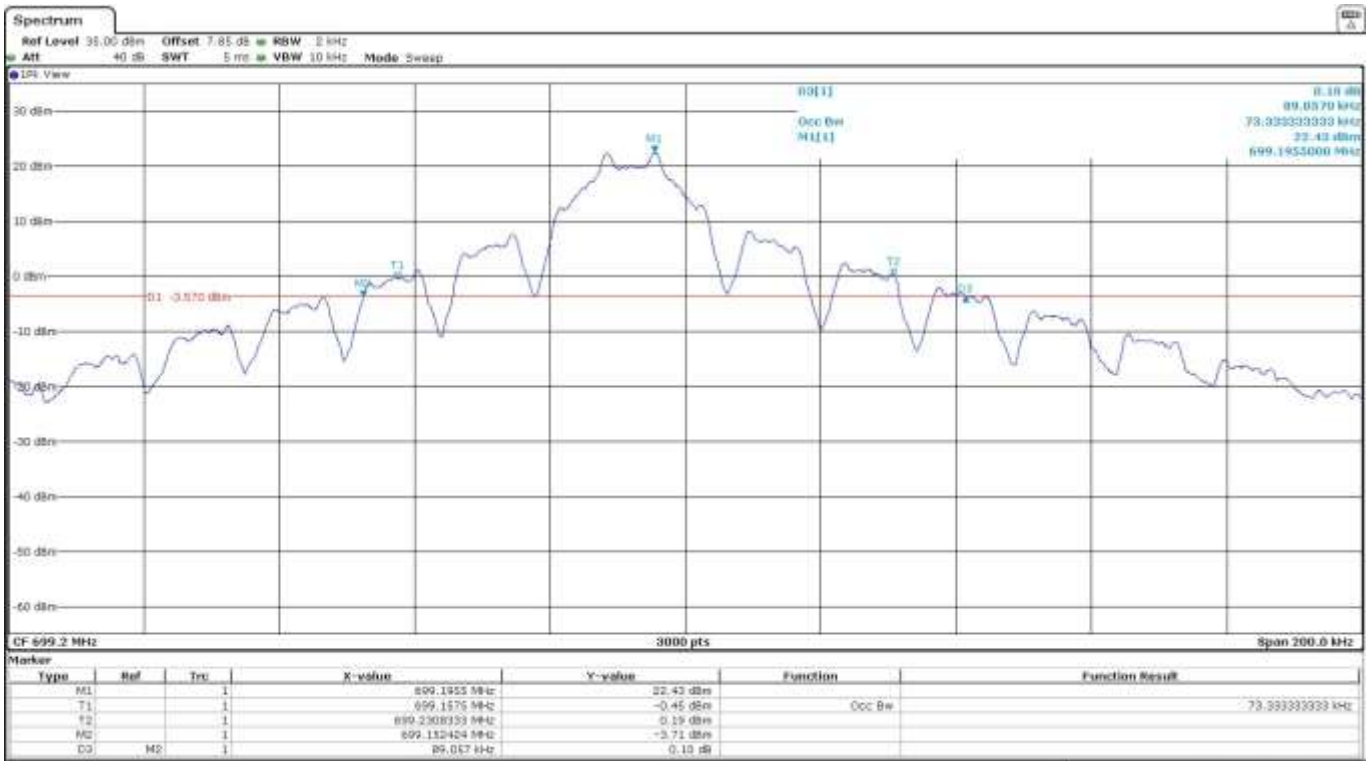

Middle Channel

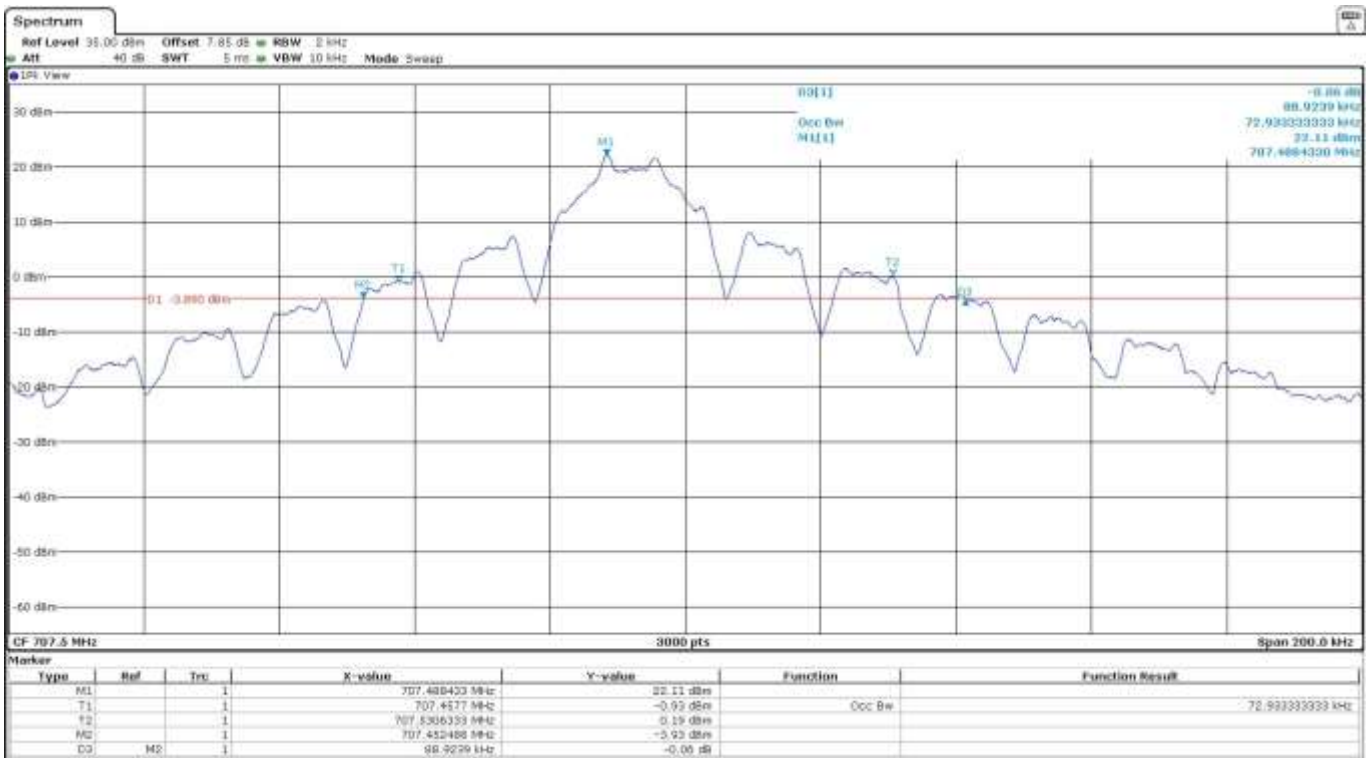

Highest Channel

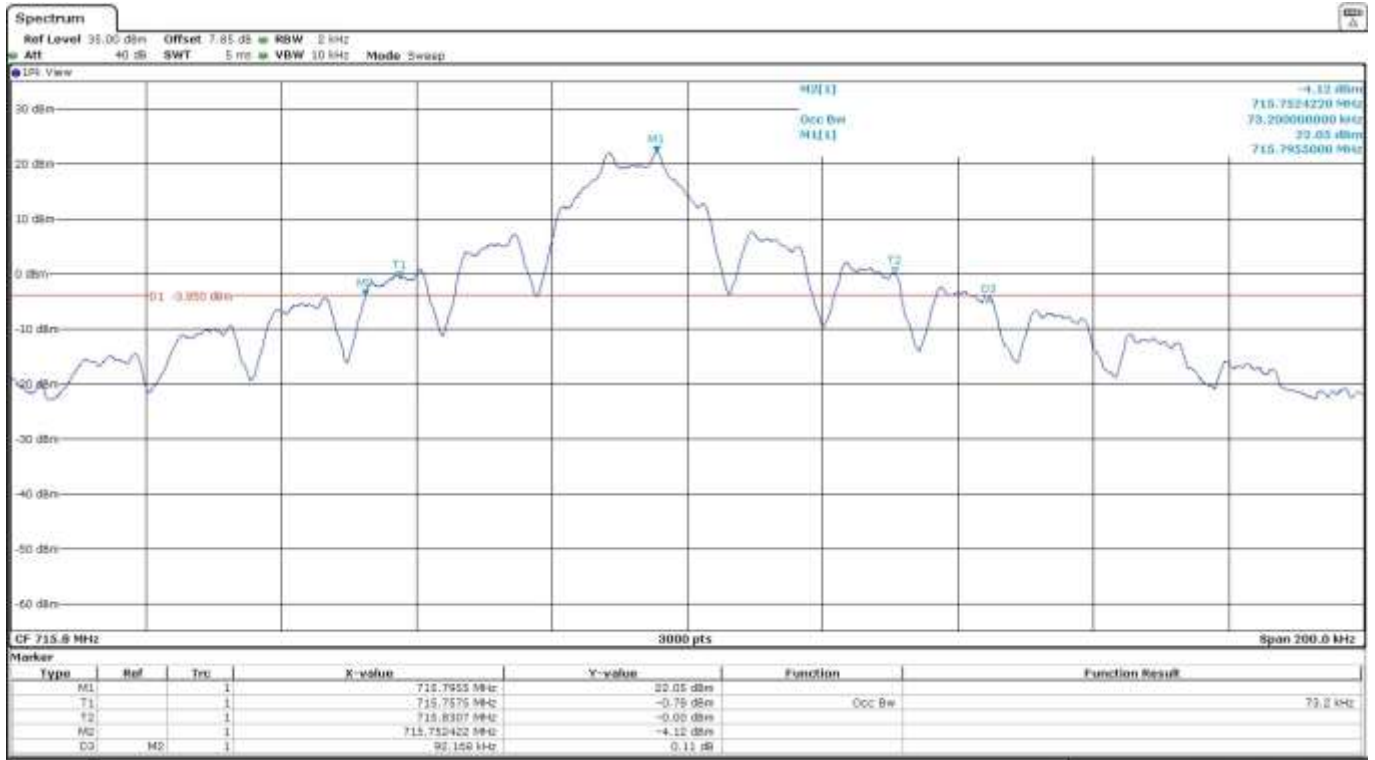

12 Tones 15 kHz. $\pi/4$ - QPSK MODULATION

Lowest Channel



Middle Channel

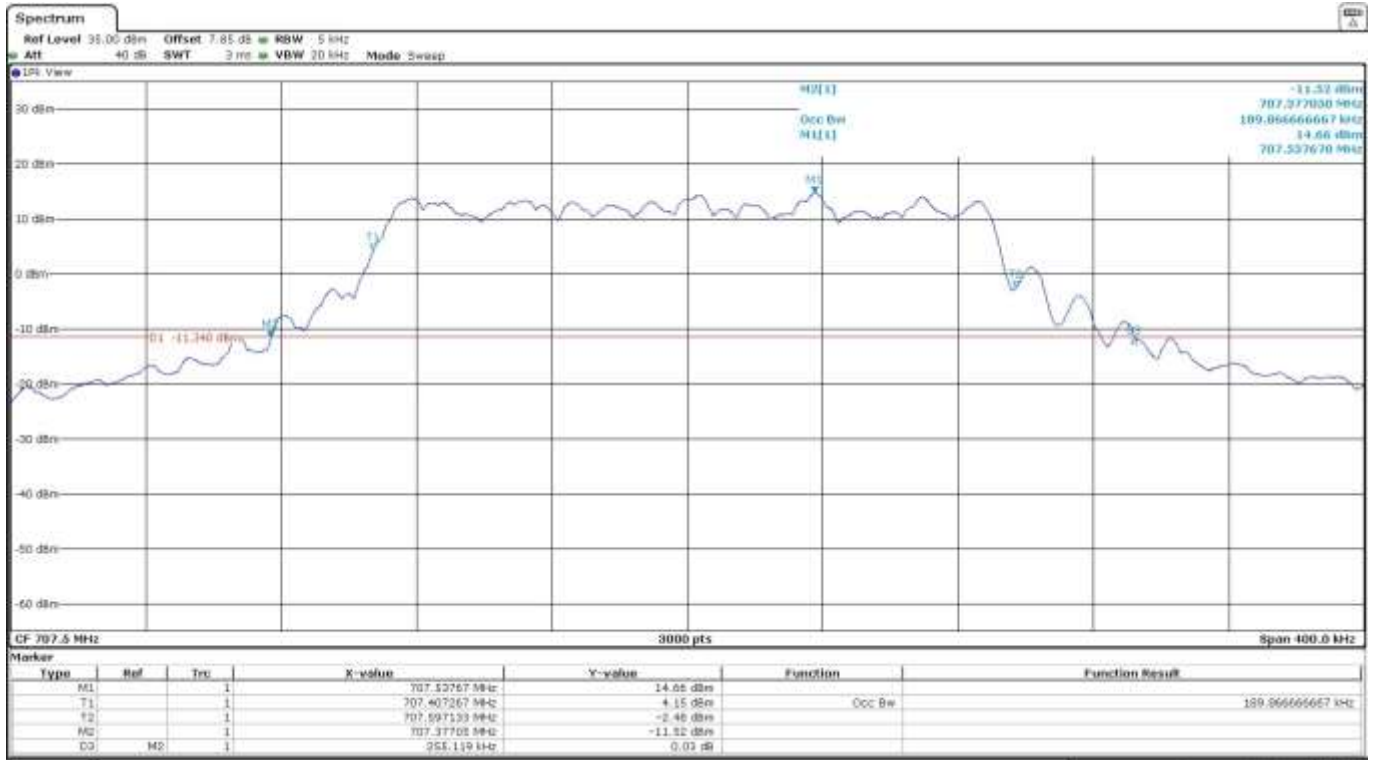

Highest Channel

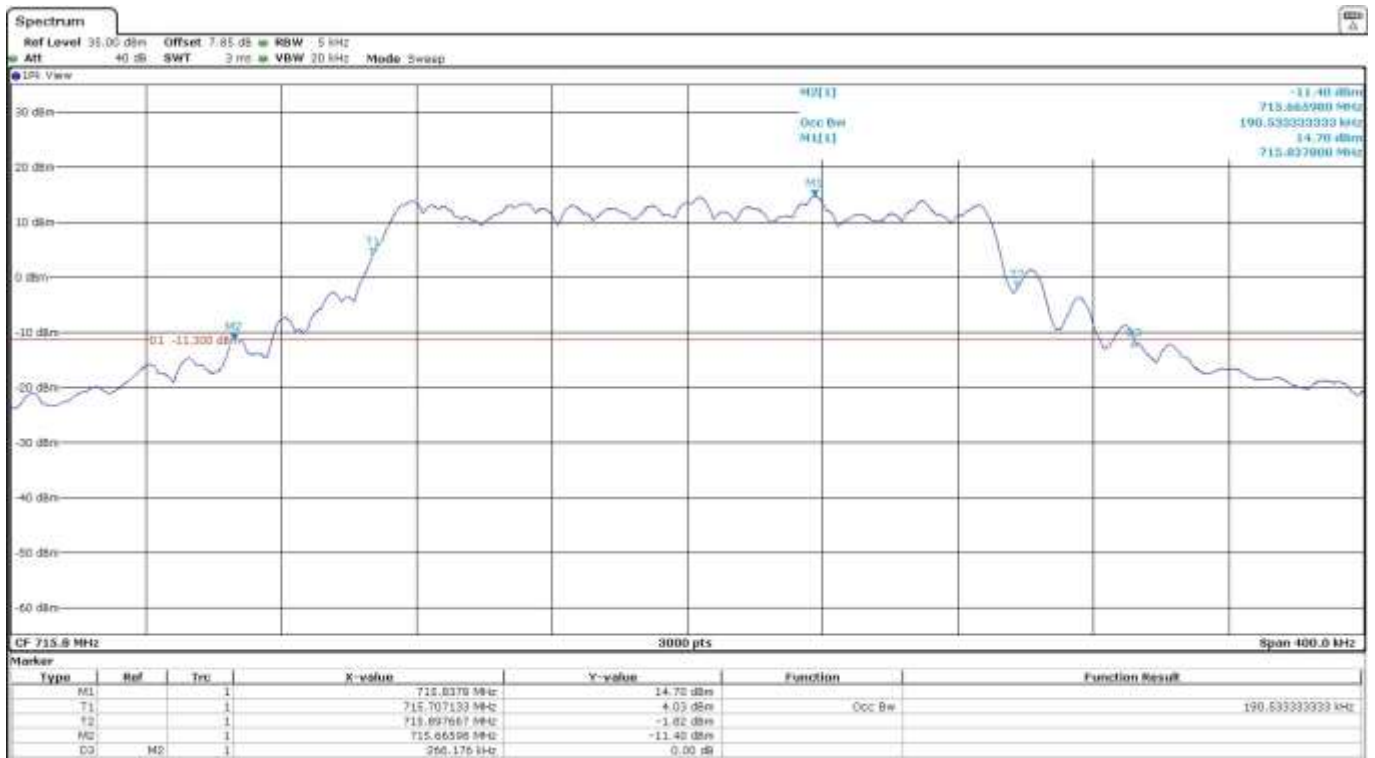

NB IoT BAND 13.

Tone 3.75 kHz. $\pi/2$ - BPSK MODULATION

Lowest Channel

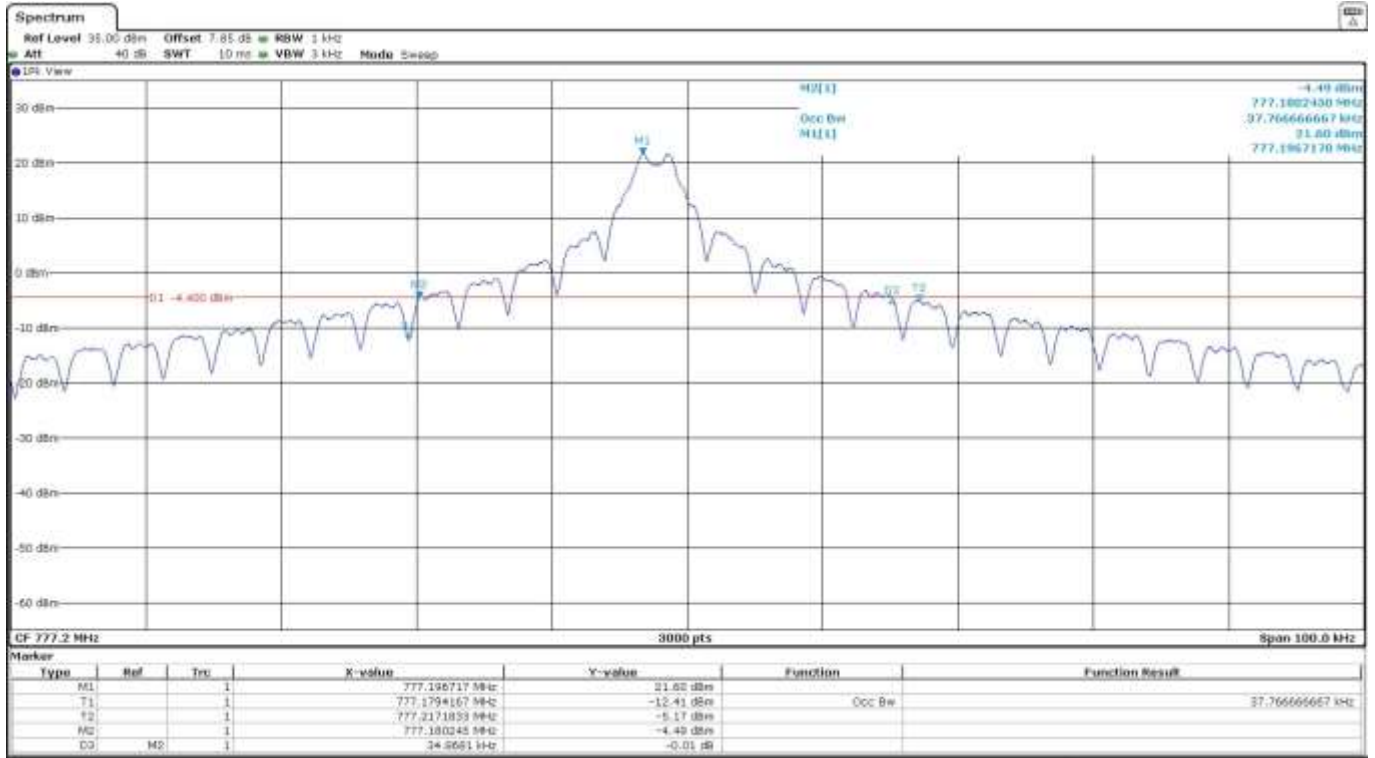

Middle Channel

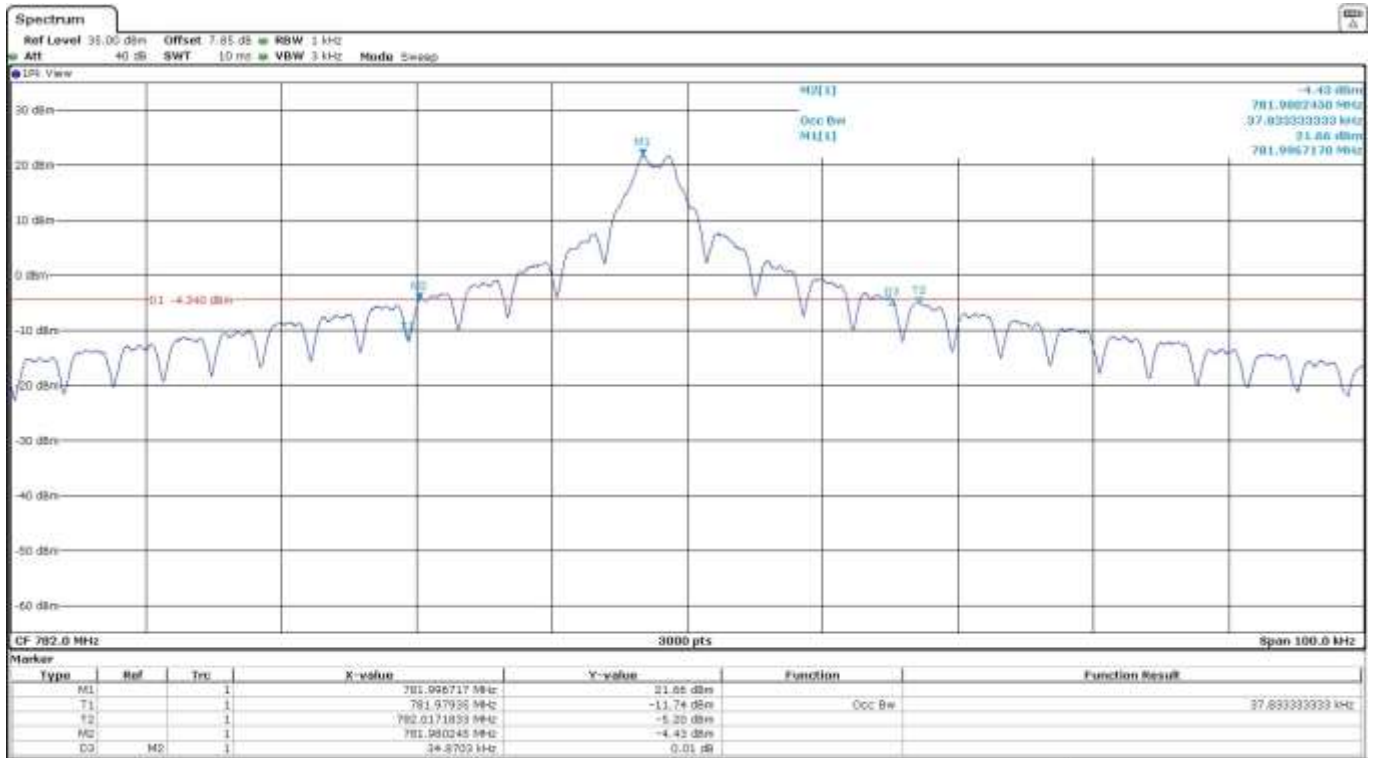

Highest Channel

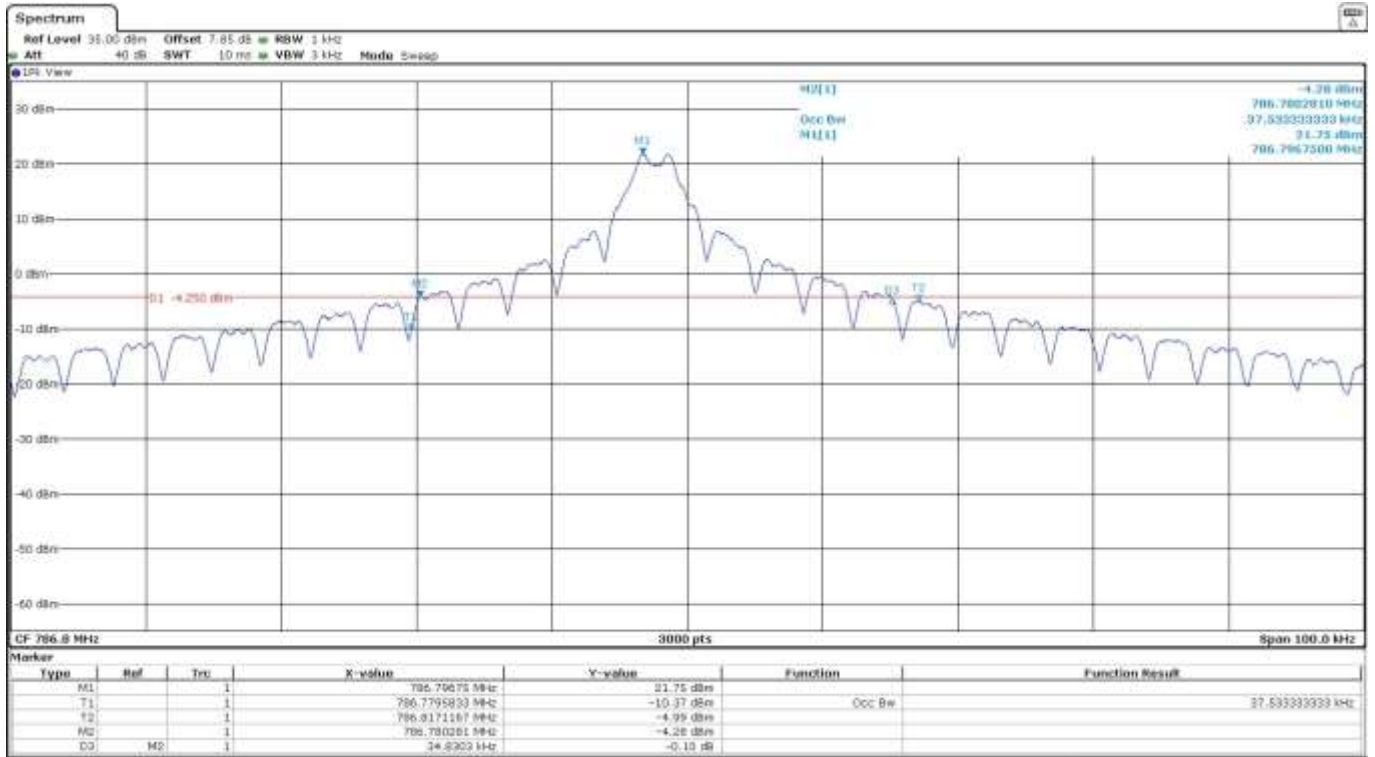

Tone 3.75 kHz. $\pi/4$ - QPSK MODULATION

Lowest Channel

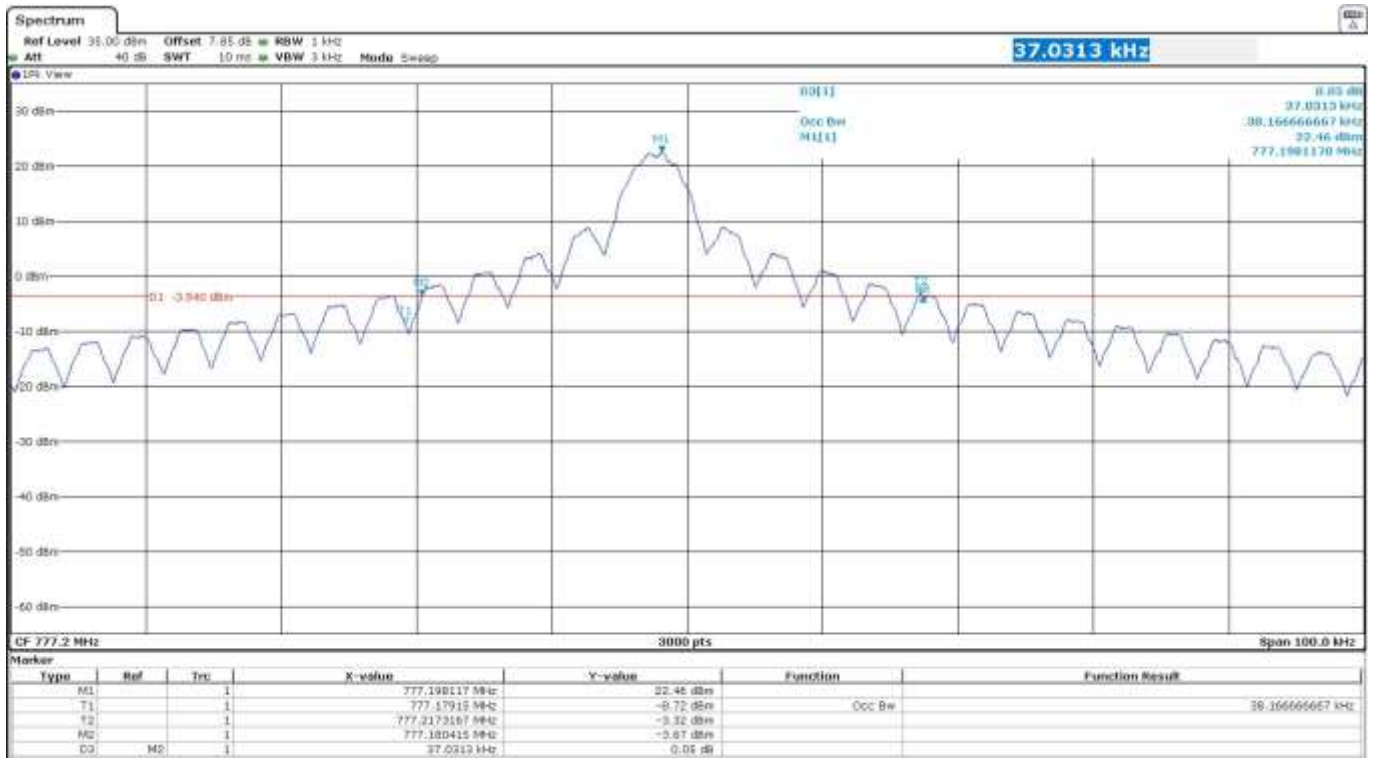

Middle Channel

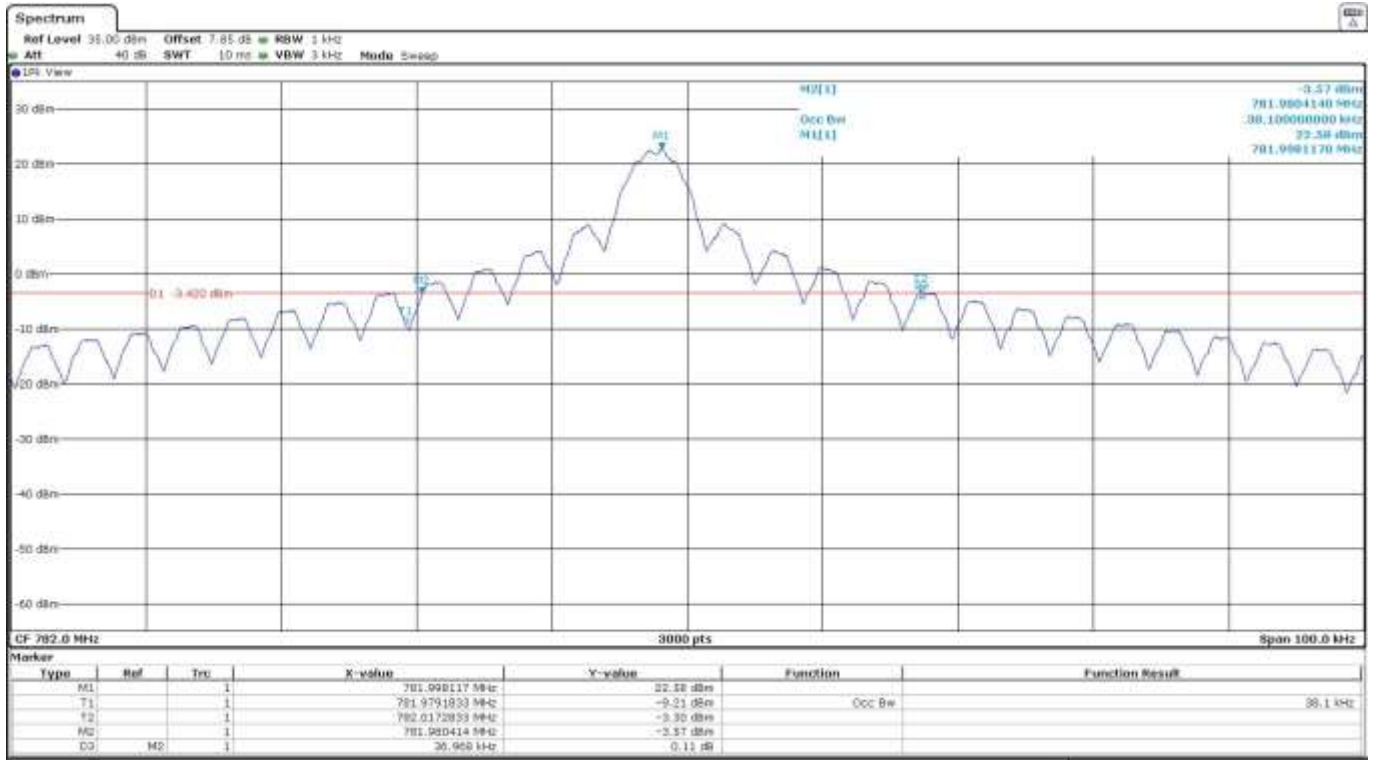

Highest Channel

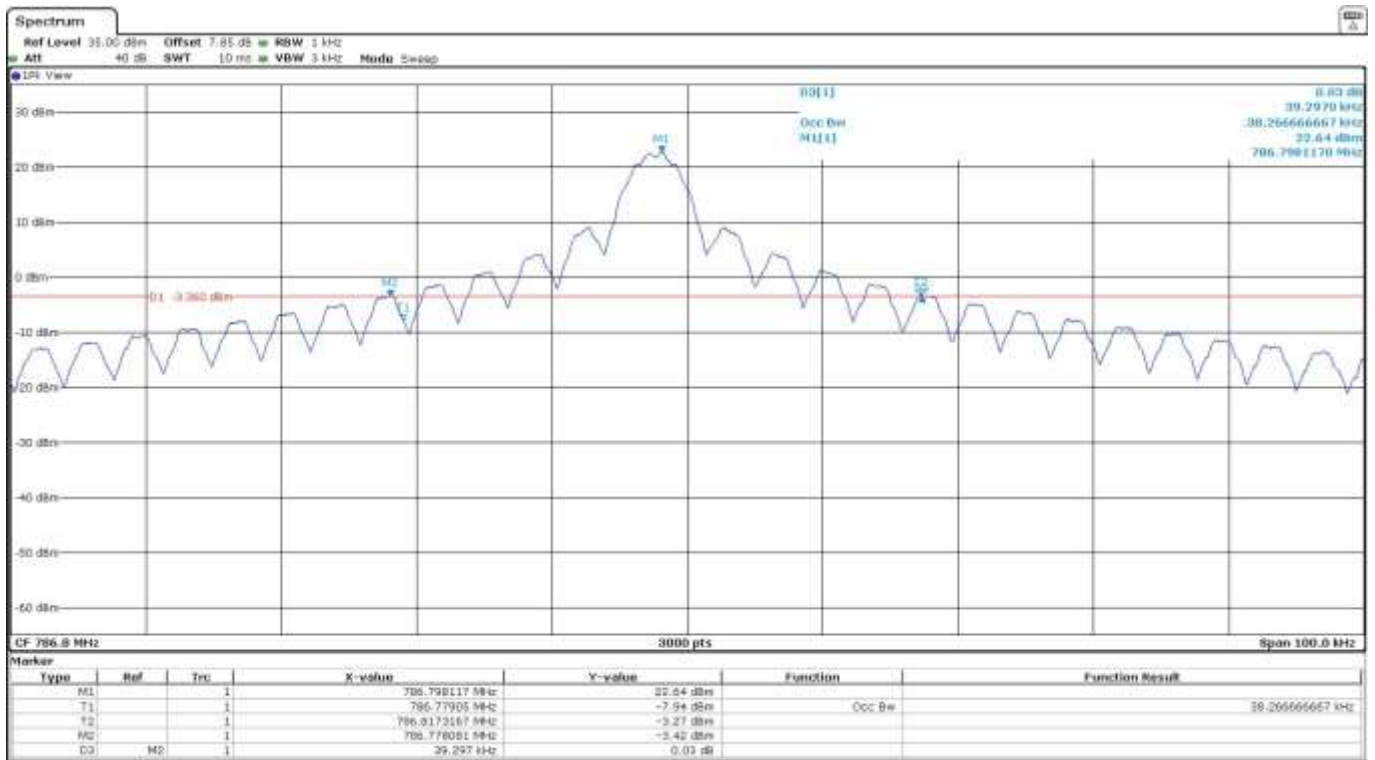

Tone 15 kHz. $\pi/2$ - BPSK MODULATION
 Lowest Channel

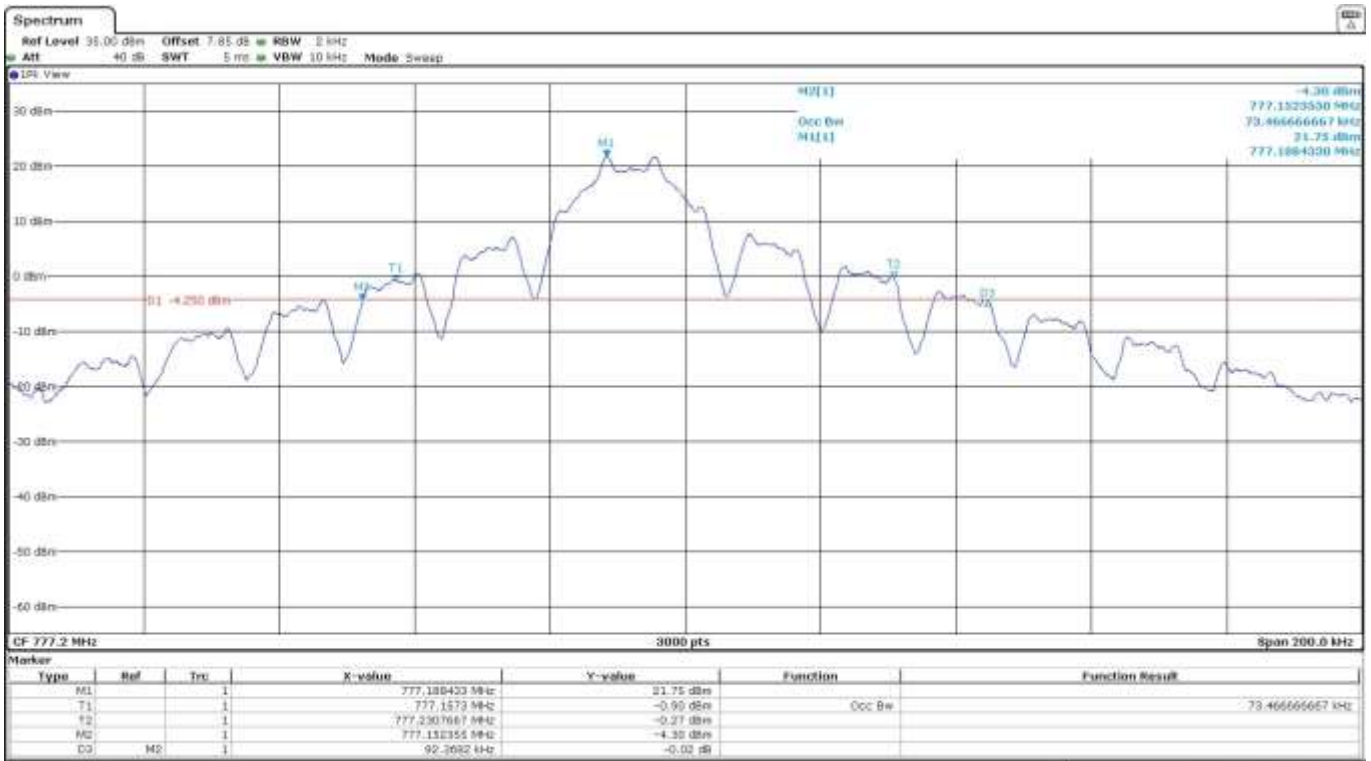

Middle Channel

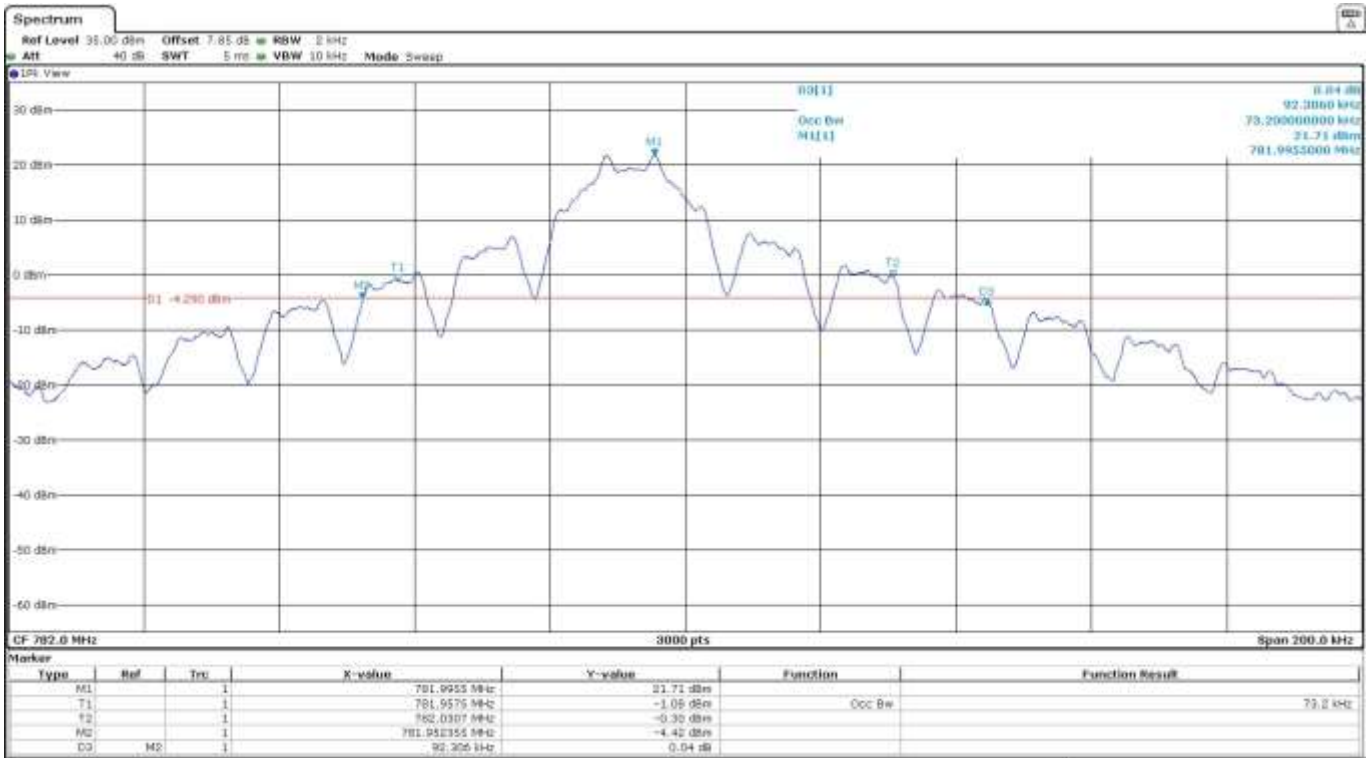

Highest Channel

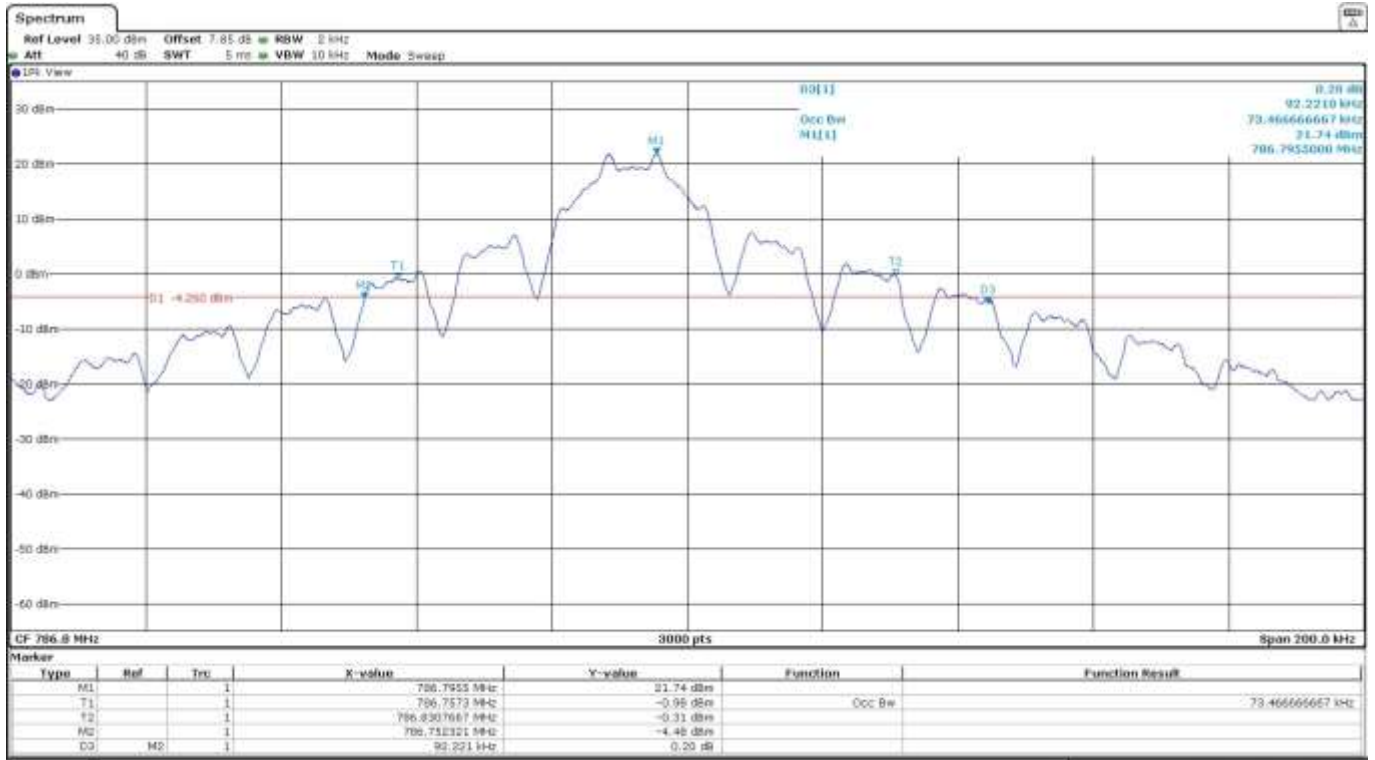

12 Tones 15 kHz. $\pi/4$ - QPSK MODULATION

Lowest Channel

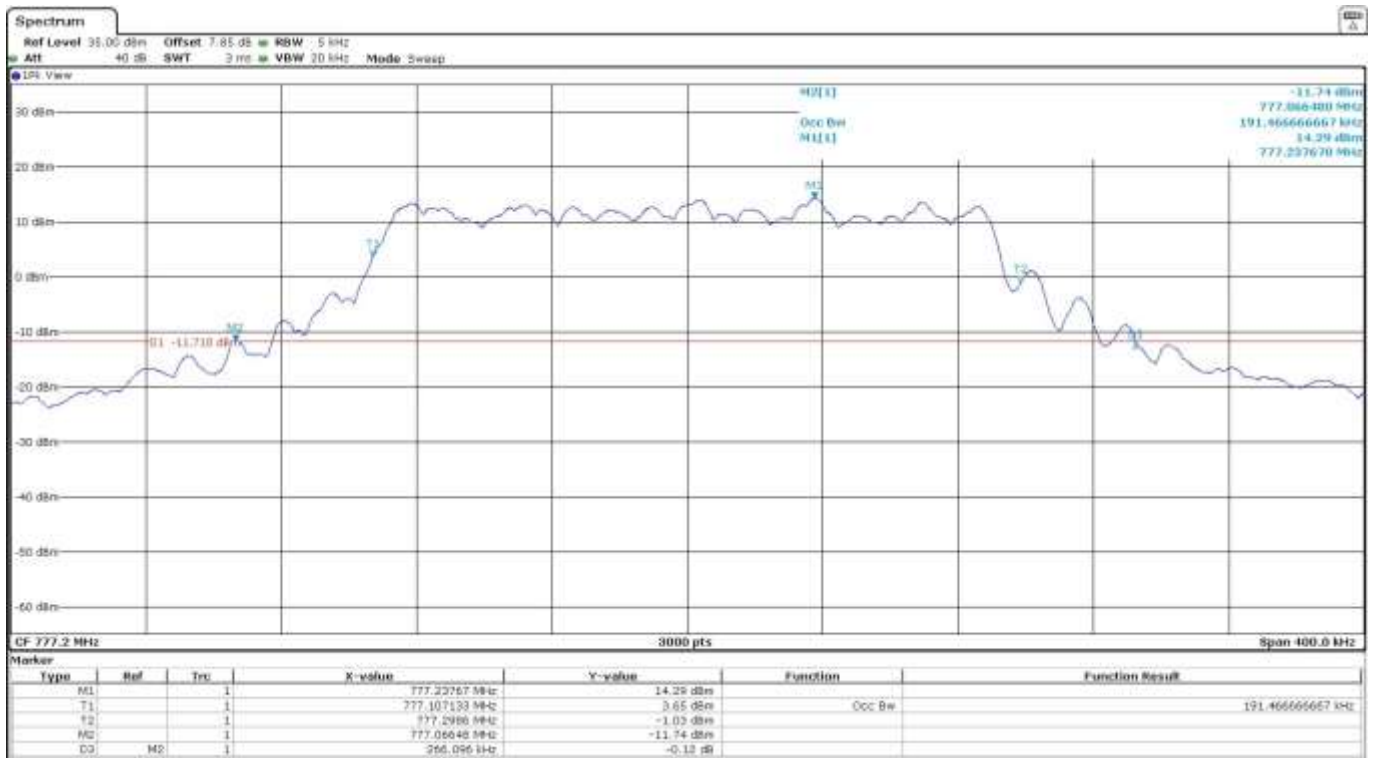

Middle Channel

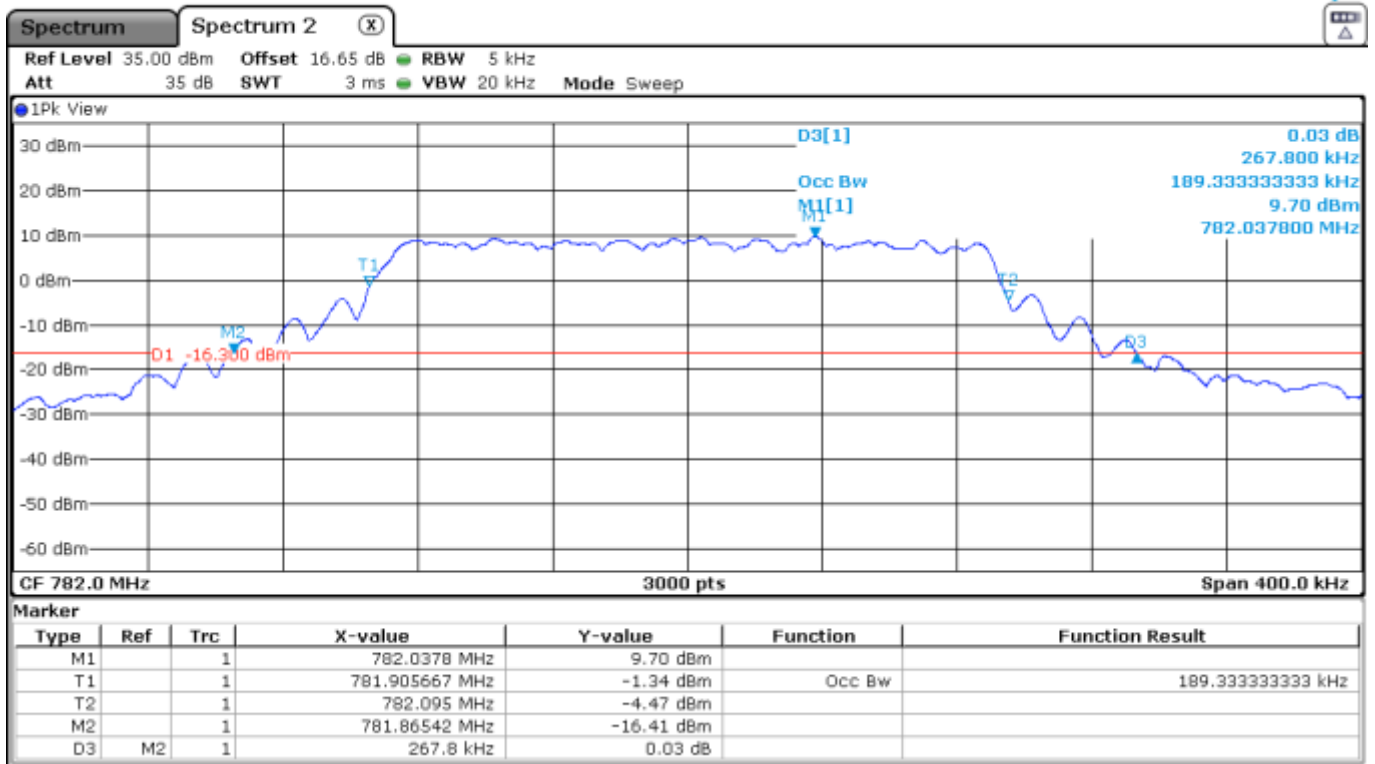

Highest Channel

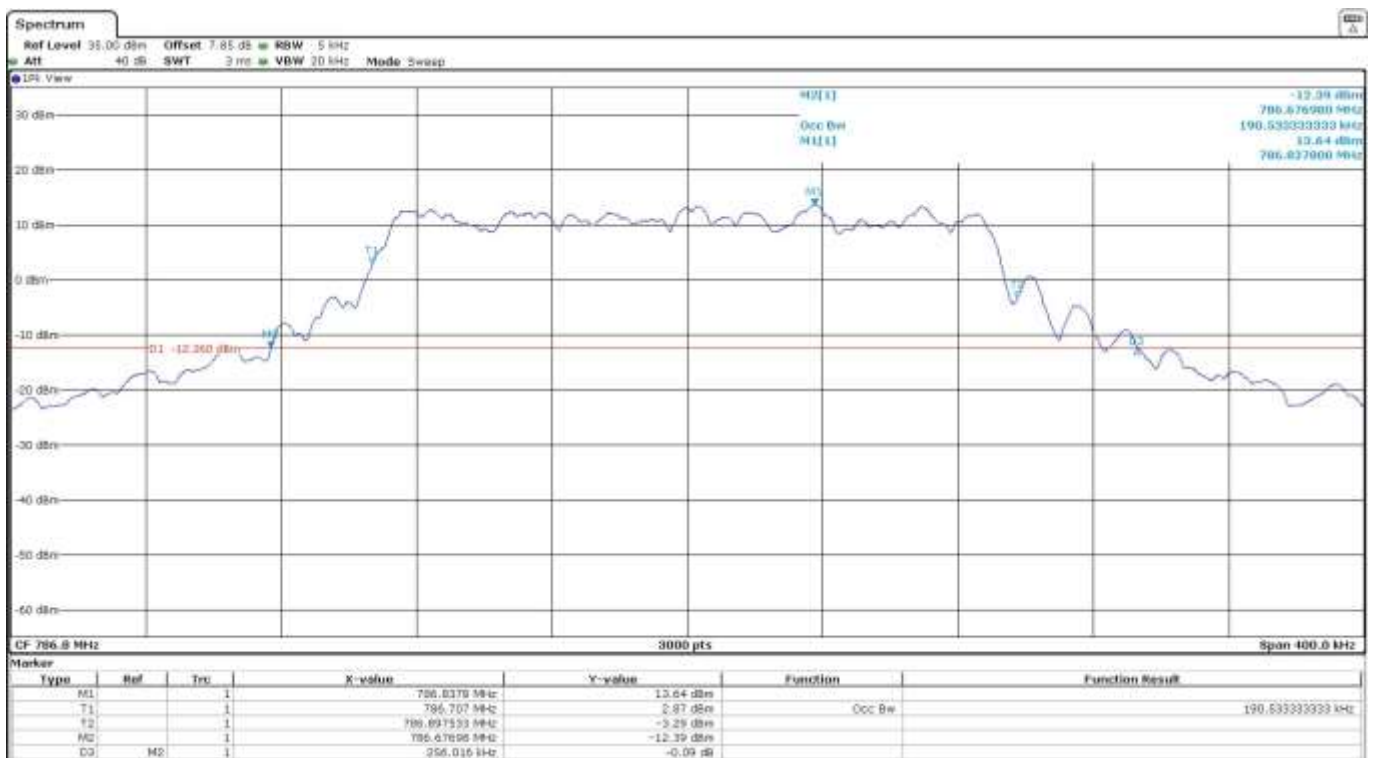

NB IoT BAND 66.

Tone 3.75 kHz. $\pi/2$ - BPSK MODULATION

Lowest Channel

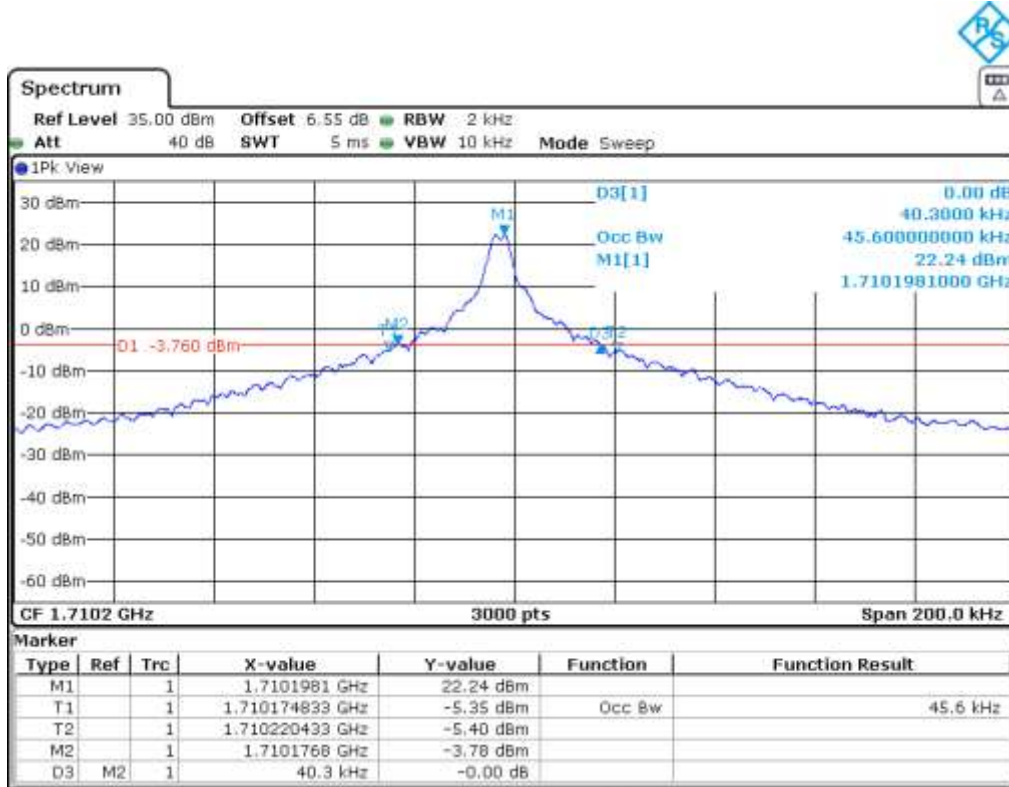

Middle Channel

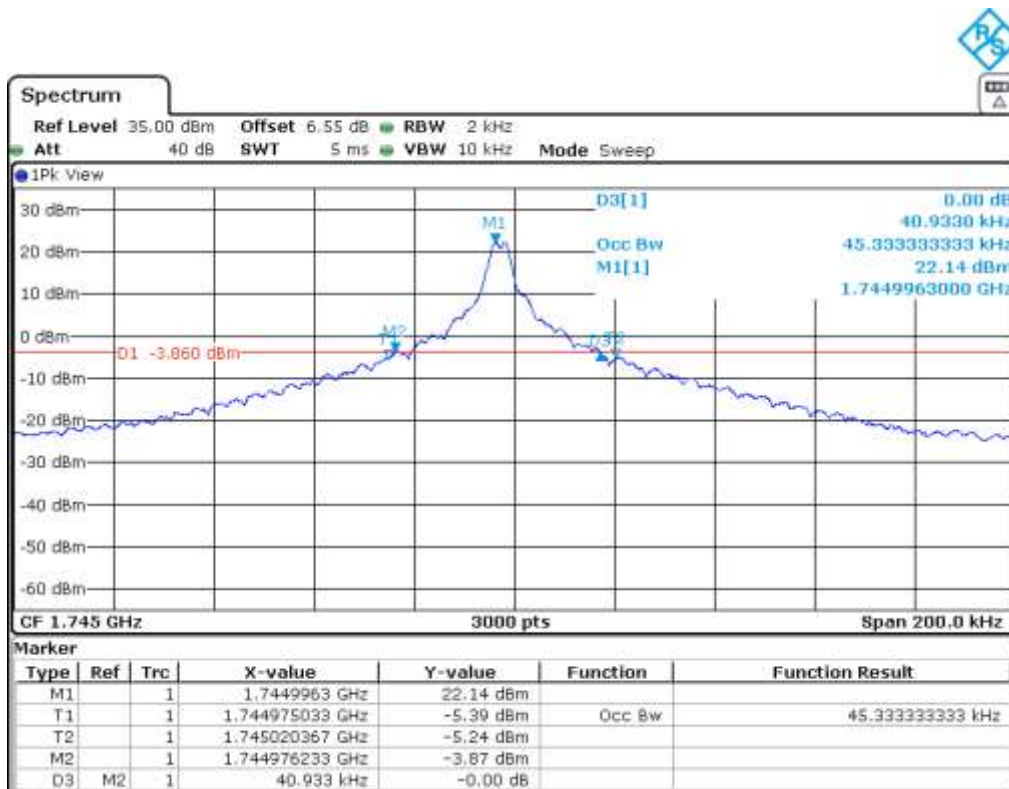

Highest Channel

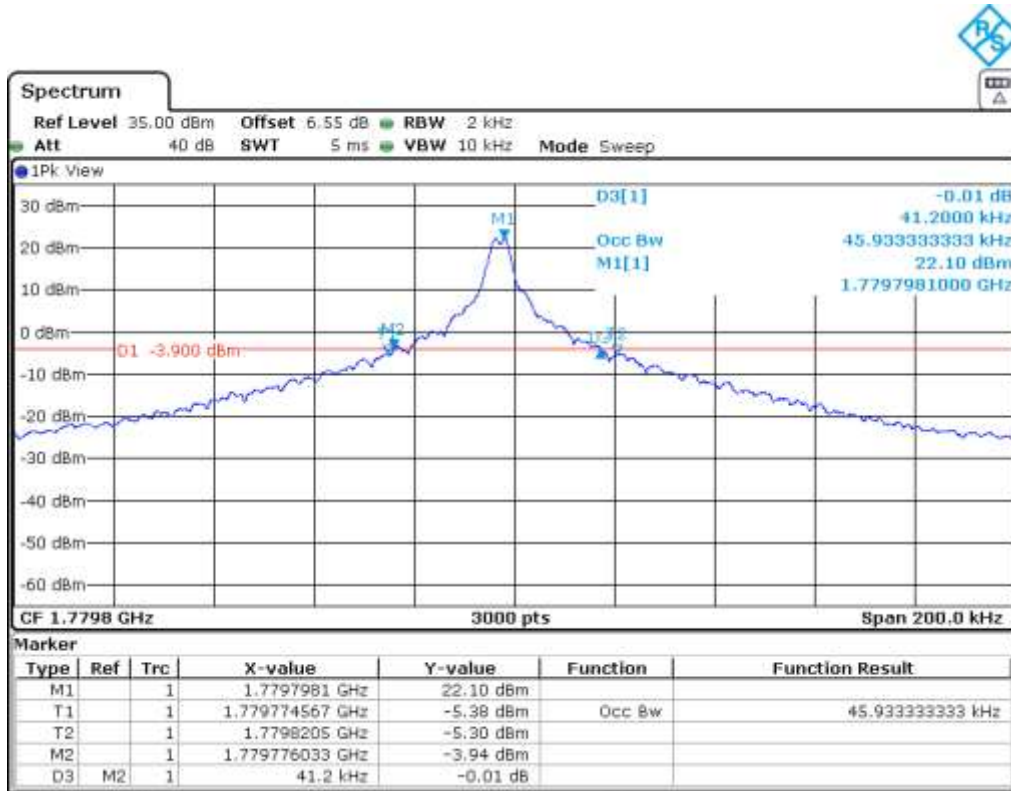

Tone 3.75 kHz. $\pi/4$ - QPSK MODULATION

Lowest Channel

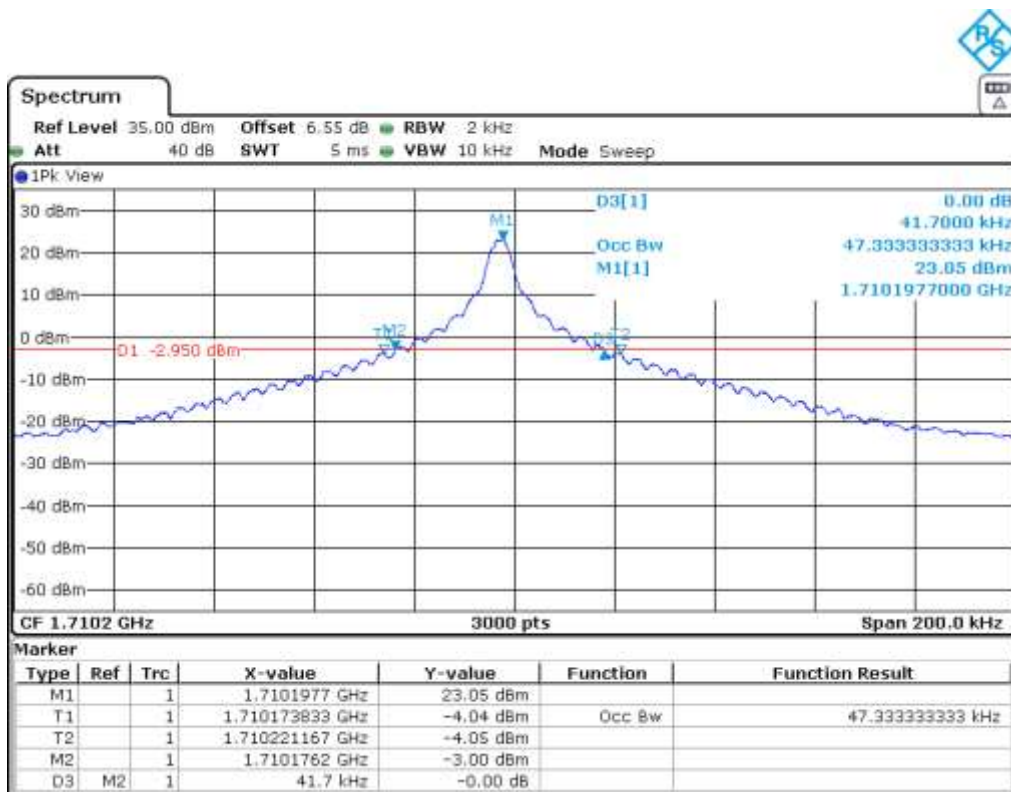

Middle Channel

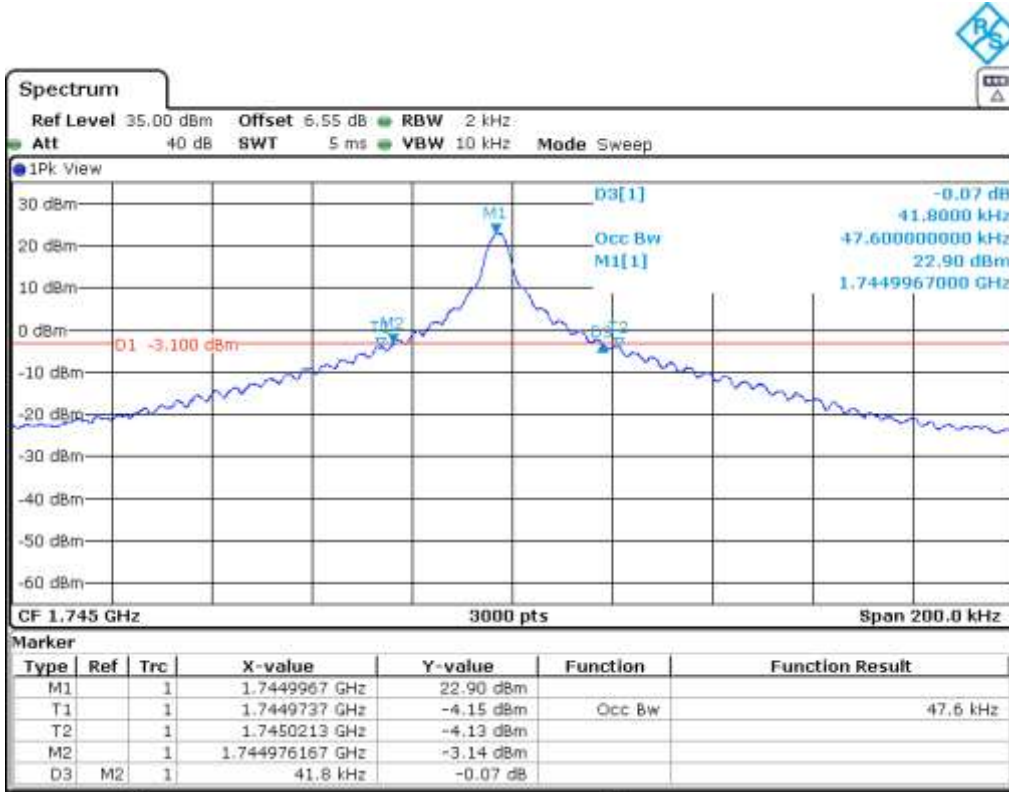

Highest Channel

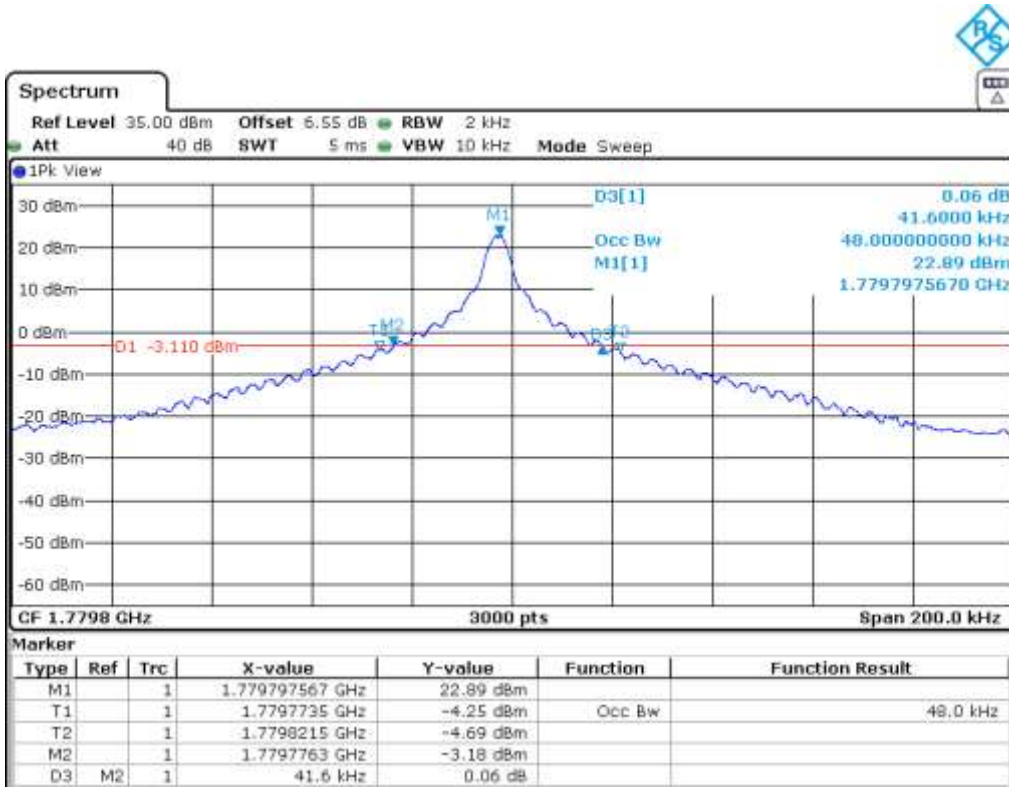

Tone 15 kHz. $\pi/2$ - BPSK MODULATION
 Lowest Channel



Middle Channel



Highest Channel



12 Tones 15 kHz. $\pi/4$ - QPSK MODULATION

Lowest Channel



Middle Channel

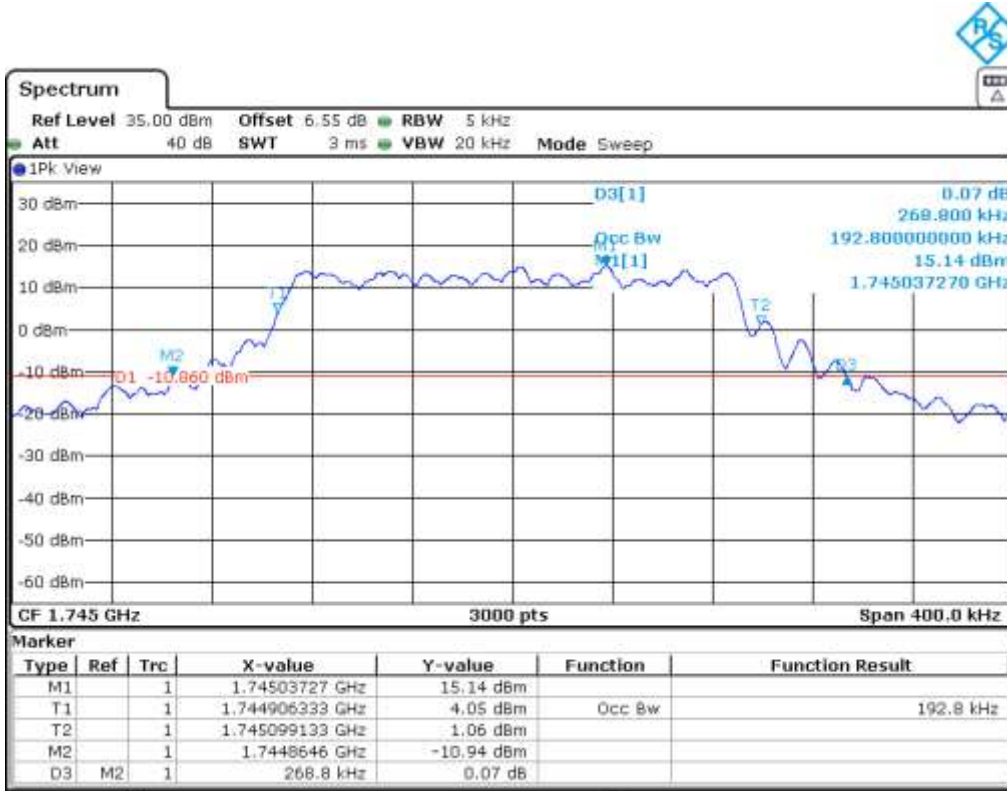

Highest Channel

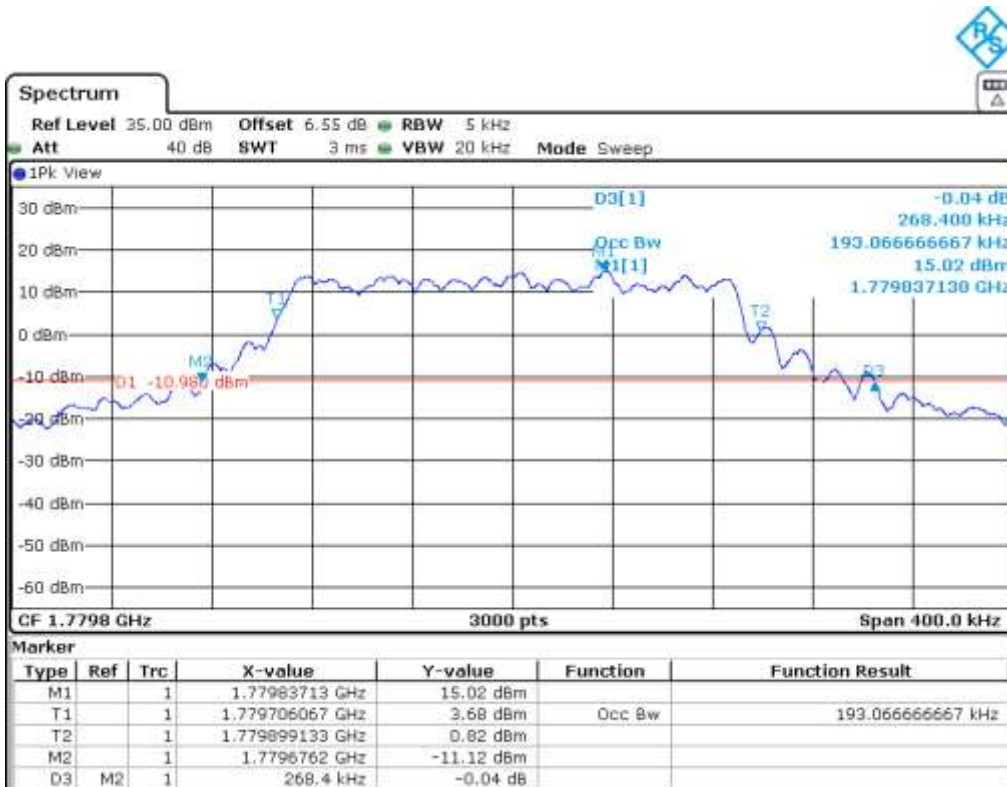

NB IoT BAND 85.

Tone 3.75 kHz. $\pi/2$ - BPSK MODULATION

Lowest Channel

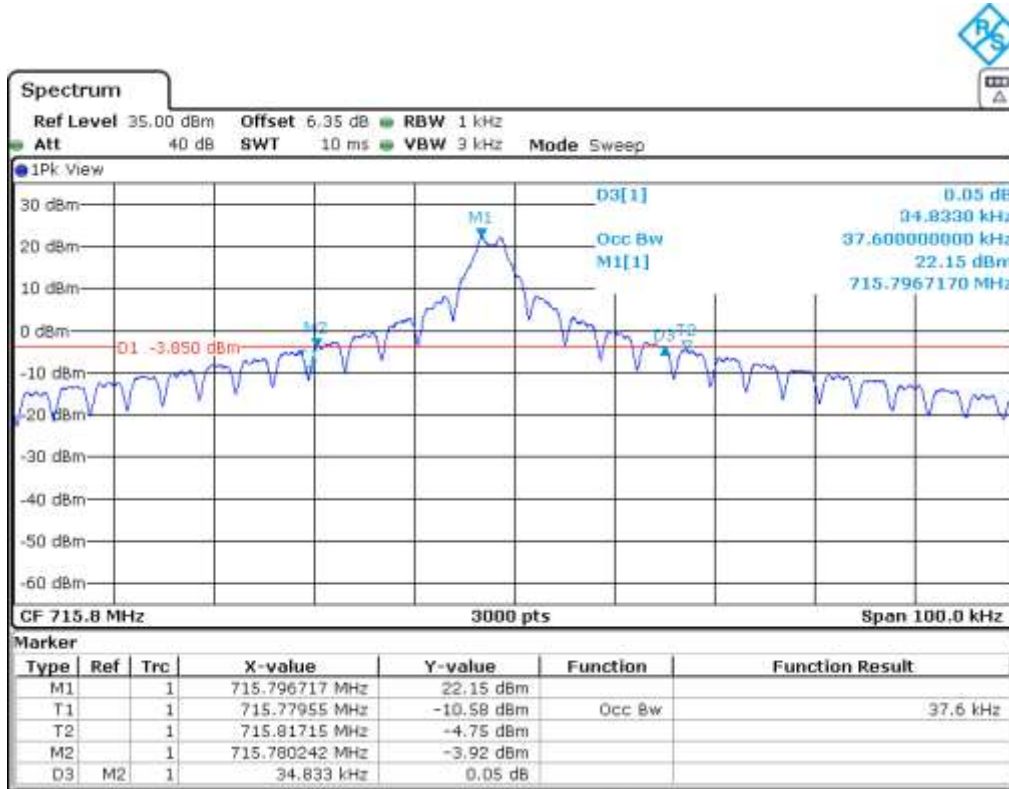

Middle Channel

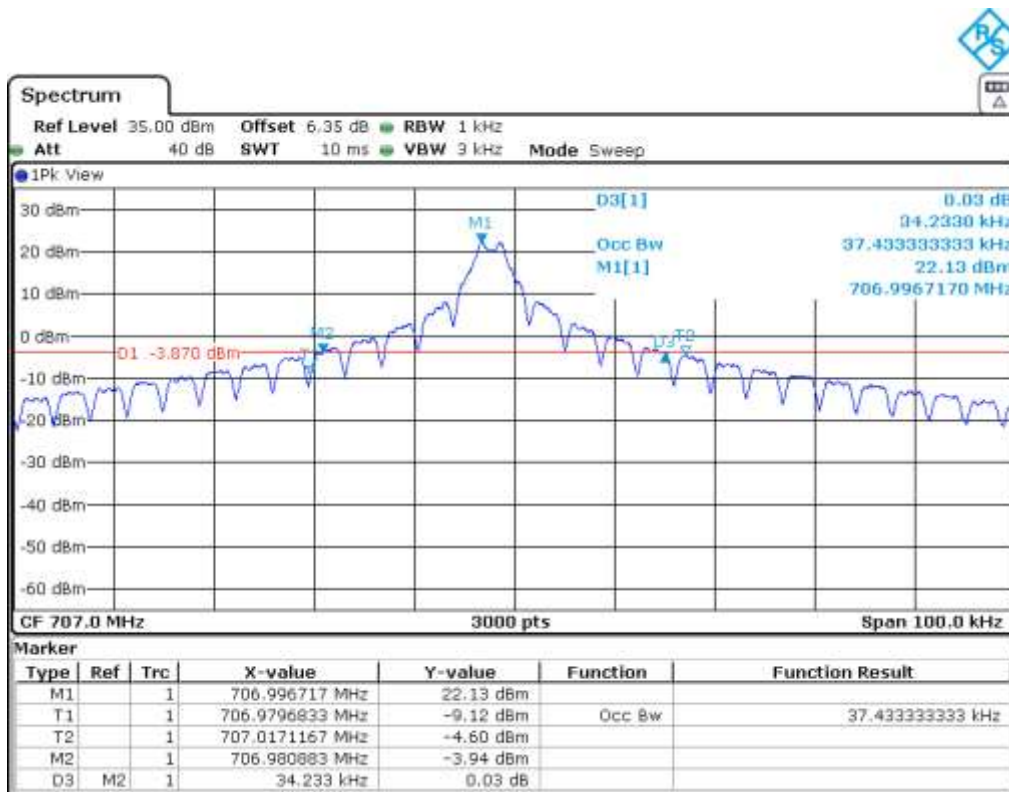

Highest Channel

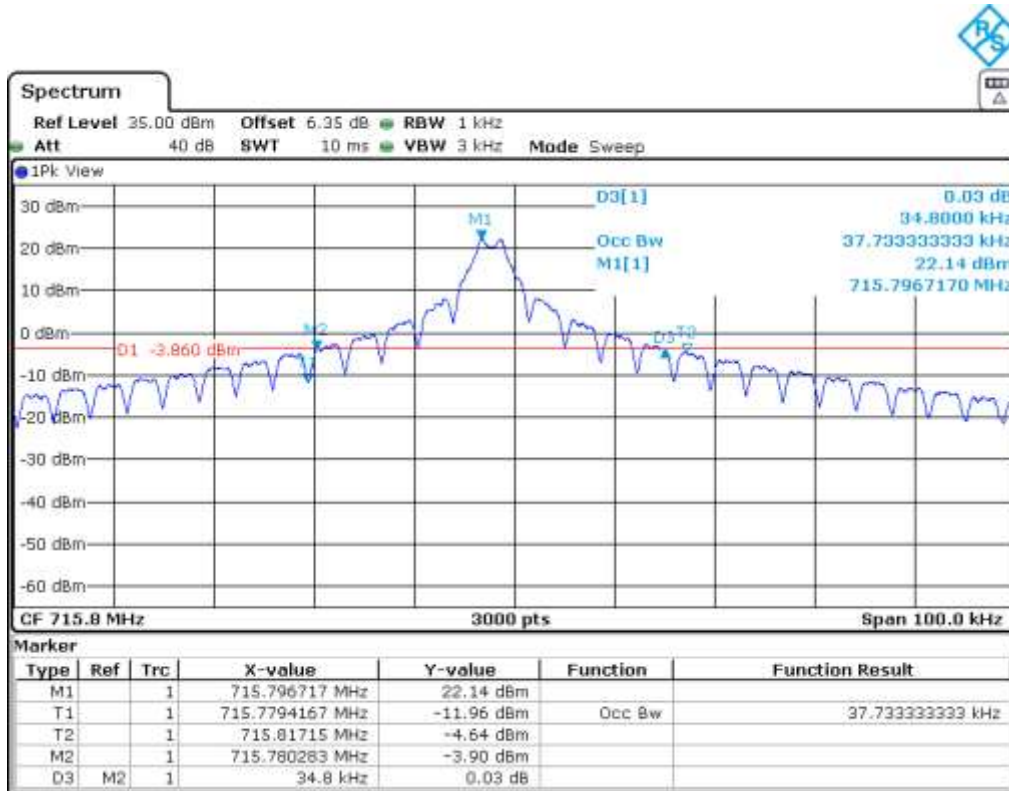

Tone 3.75 kHz. $\pi/4$ - QPSK MODULATION

Lowest Channel

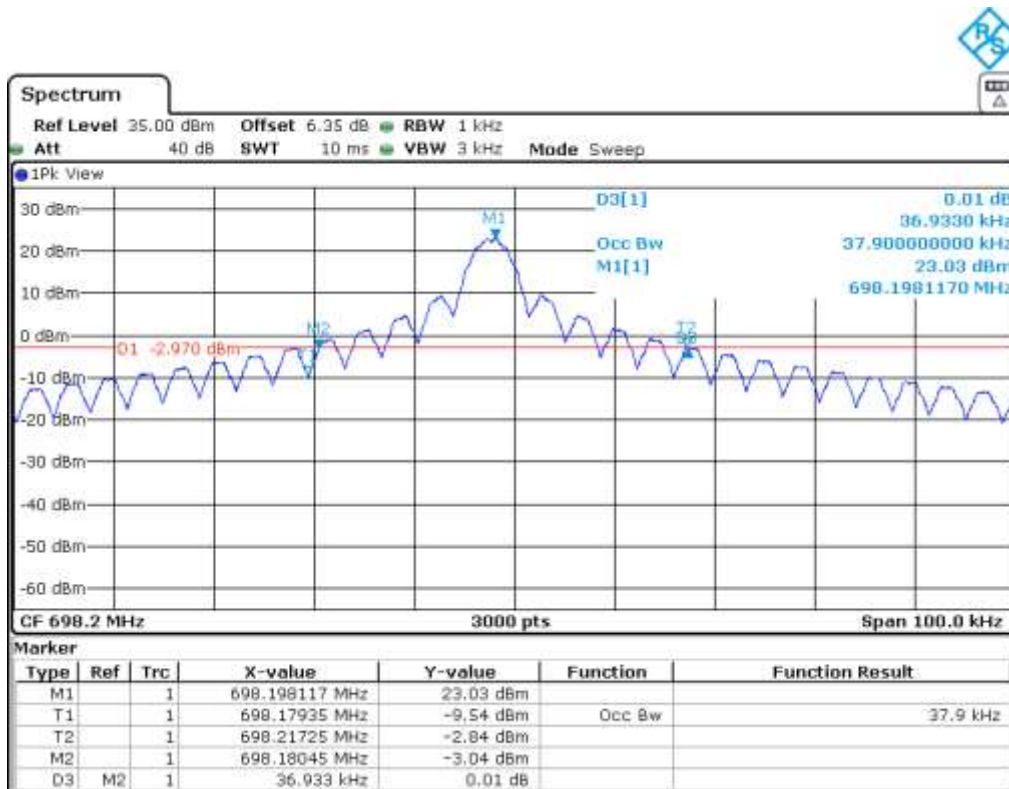

Middle Channel

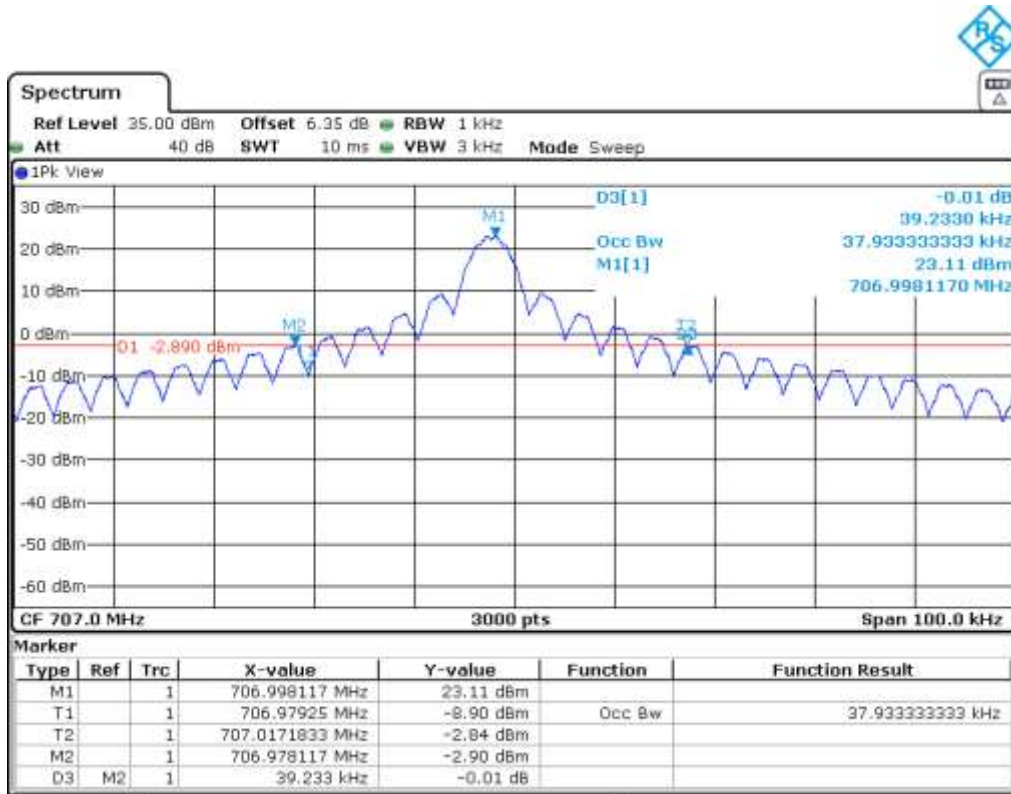

Highest Channel

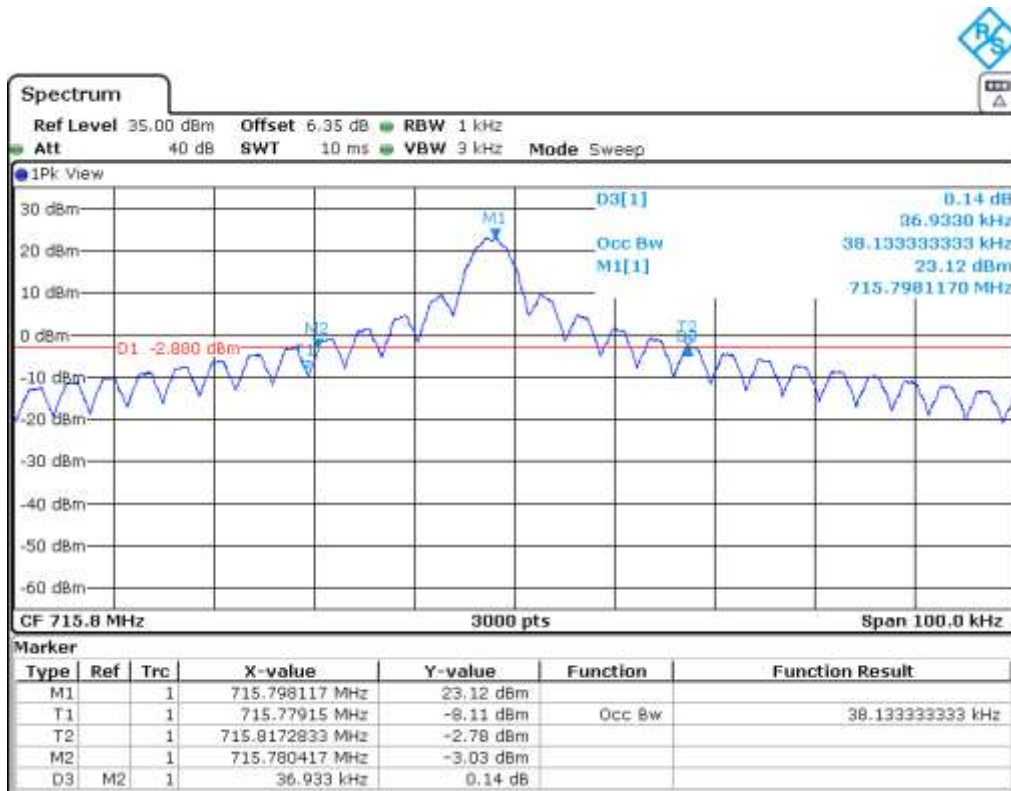

Tone 15 kHz. $\pi/2$ - BPSK MODULATION
 Lowest Channel



Middle Channel



Highest Channel



12 Tones 15 kHz. $\pi/4$ - QPSK MODULATION

Lowest Channel

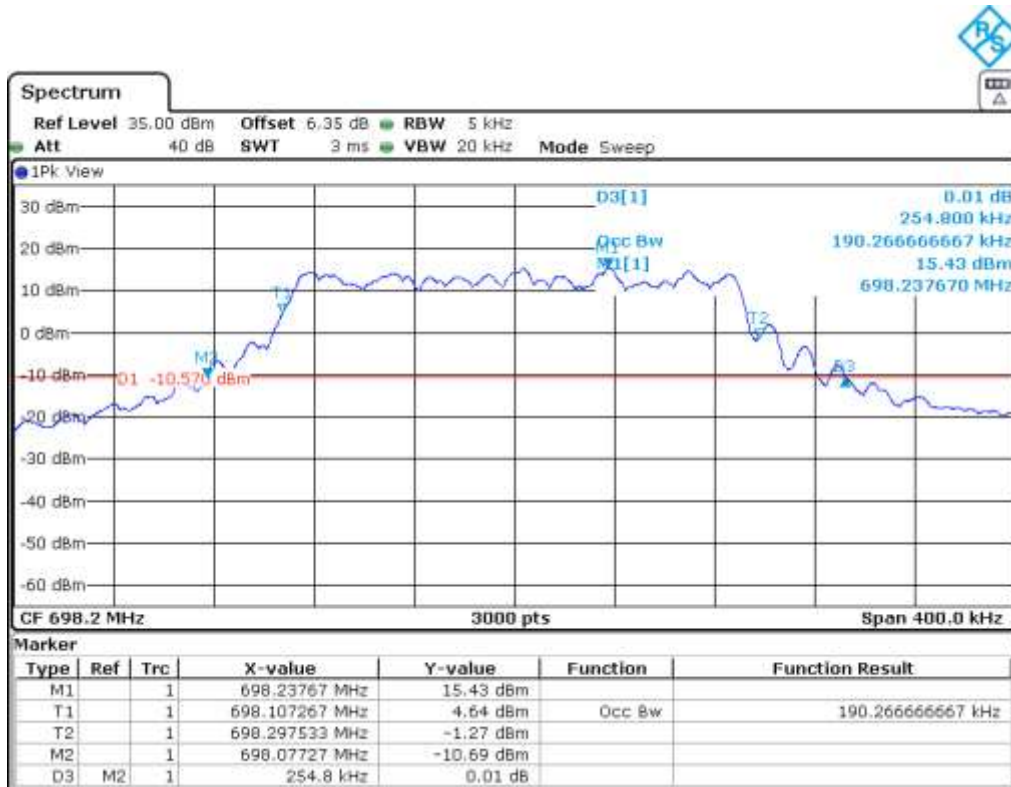

Middle Channel

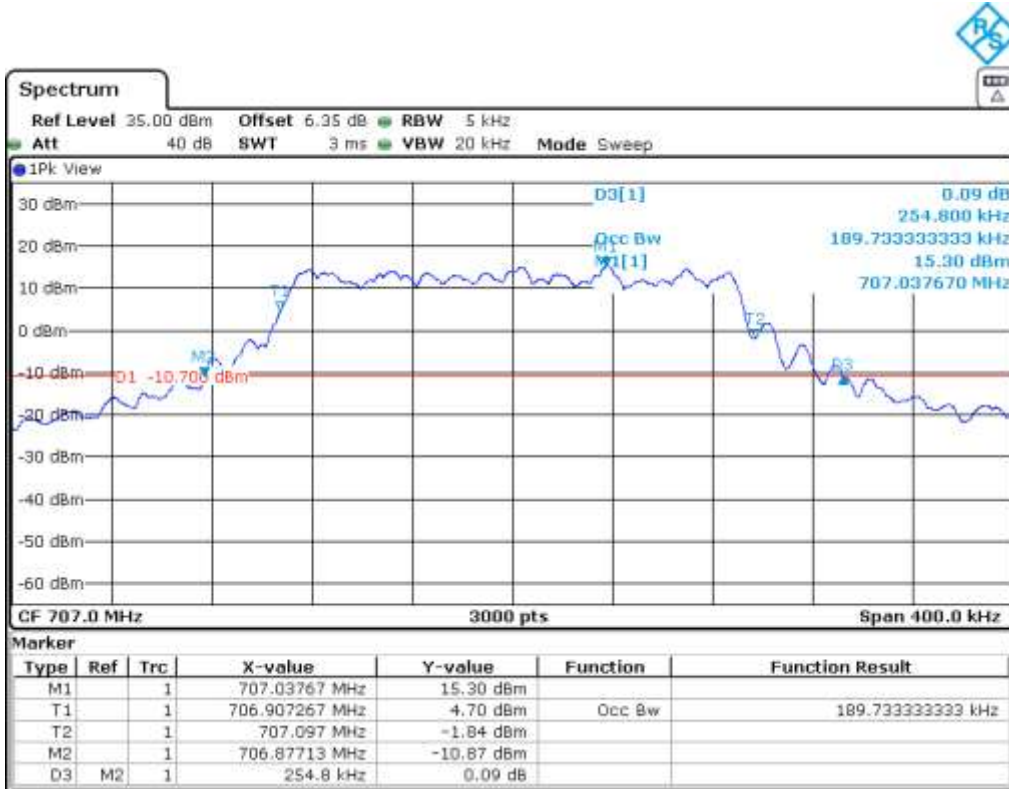

Highest Channel

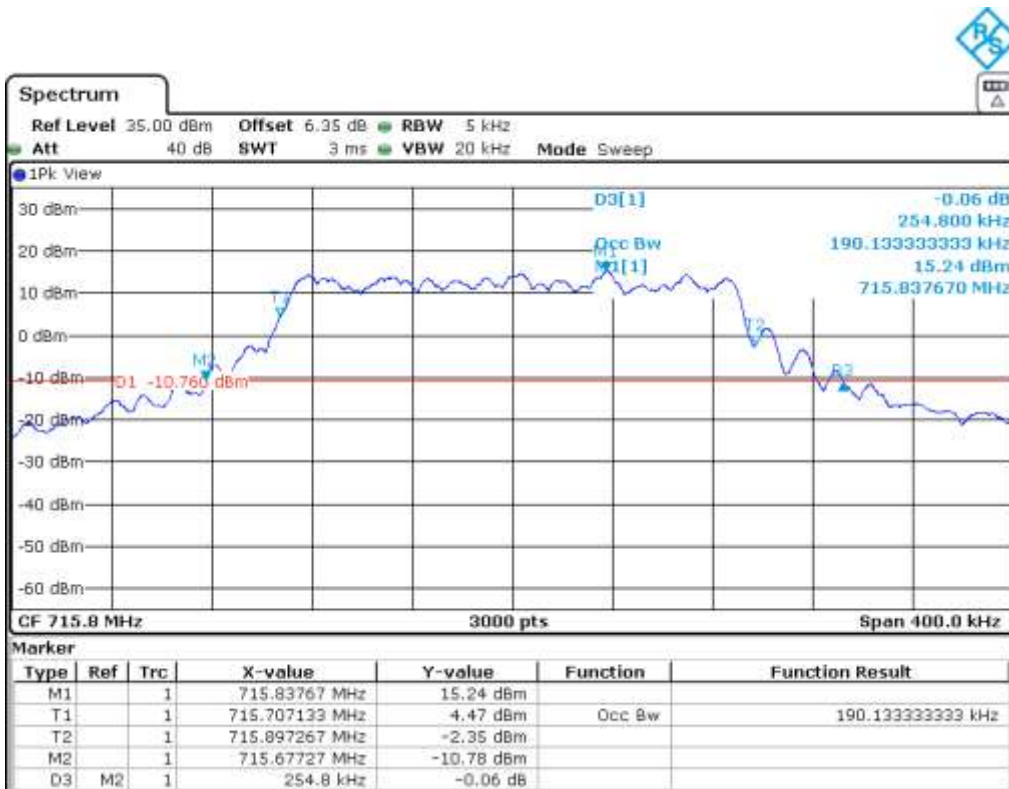

Spurious emissions at antenna terminals

SPECIFICATION

FCC §27.53 (g).

For operations in the 600 MHz band and the 698-746 MHz band. the power of any emission outside a licensee's frequency band(s) of operation shall be attenuated below the transmitter power (P) within the licensed band(s) of operation. measured in watts. by at least $43 + 10 \log (P)$ dB. Compliance with this provision is based on the use of measurement instrumentation employing a resolution bandwidth of 100 kilohertz or greater. However. in the 100 kilohertz bands immediately outside and adjacent to a licensee's frequency block. a resolution bandwidth of at least 30 kHz may be employed

FCC §27.53 (c).

On any frequency outside the 776-788 MHz band. the power of any emission shall be attenuated outside the band below the transmitter power (P) by at least $43 + 10 \log (P)$ dB.

On all frequencies between 763-775 MHz and 793-805 MHz. by a factor not less than $65 + 10 \log (P)$ dB in a 6.25 kHz band segment. for mobile and portable stations.

RSS-130 Clause 4.7.

The unwanted emissions in any 100 kHz bandwidth on any frequency outside the low frequency edge and the high frequency edge of each frequency block range(s), shall be attenuated below the transmitter power, P (dBW), by at least $43 + 10 \log_{10} p$ (watts), dB. However, in the 100 kHz band immediately outside of the equipment's frequency block range, a resolution bandwidth of 30 kHz may be employed.

The power of any unwanted emissions in any 6.25 kHz bandwidth for all frequencies between 763-775 MHz and 793-806 MHz shall be attenuated below the transmitter power. P (dBW). by at least $65 + 10 \log_{10} p$ (watts). dB. for mobile and portable equipment.

FCC §27.53 (h). RSS-139 Clause 6.6.

According to specification. the power of emissions shall be attenuated below the transmitter power (P) by a factor of at least $43 + 10 \log (P)$ dB. P in watts.

At P_o transmitting power. the specified minimum attenuation becomes $43+10 \log (P_o)$. and the level in dBm relative P_o becomes:

$$P_o \text{ (dBm)} - [43 + 10 \log (P_o \text{ in mwatts}) - 30] = -13 \text{ dBm.}$$

At P_o transmitting power. the specified minimum attenuation becomes $65+10 \log (P_o)$. and the level in dBm relative P_o becomes:

$$P_o \text{ (dBm)} - [65 + 10 \log (P_o \text{ in mwatts}) - 30] = -35 \text{ dBm.}$$

METHOD

The EUT RF output connector was connected to a spectrum analyser and to the Universal Radio Communication tester R&S CMW500 (selecting maximum transmission power of the EUT and different modes of modulation) using a 50 ohm attenuator and a power divider.

The spectrum was investigated from 9 kHz to 18 GHz for NBloT Band 66 and from 9 kHz to 8 GHz for NBloT Band 12 and 13.

The reading of the spectrum analyser is corrected with the attenuation loss of connection between output terminal of EUT and input of the spectrum analyser.

The configuration of tones and modulation which is the worst case for conducted power was used.

TEST SETUP

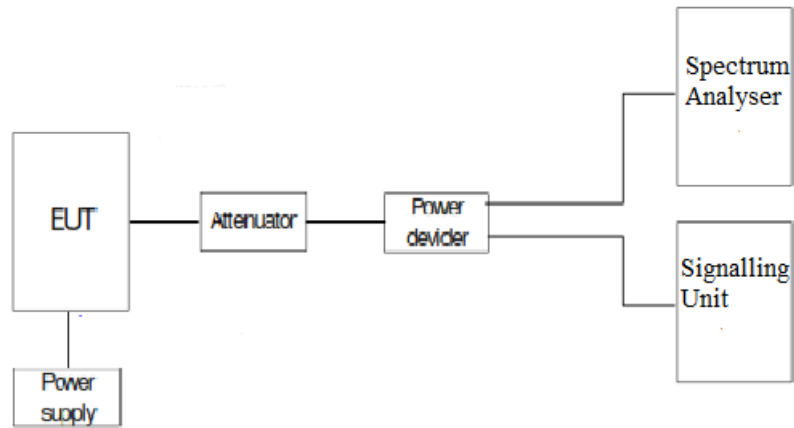

RESULTS (see plots in next pages)

NBLoT Band 12 (1 Tone 3.75 kHz. $\pi/2$ - BPSK MODULATION)

1. CHANNEL: LOWEST

No spurious signals were found at less than 20dB respect to the limit in all the range.

2. CHANNEL: MIDDLE

Frequency (GHz)	Level (dBm)	Limit (dBm)
1.41508	-32.97	-13.00

3. CHANNEL: HIGHEST

Frequency (GHz)	Level (dBm)	Limit (dBm)
1.43188	-32.99	-13.00

NBLoT Band 12 (3 Tone 15 kHz. $\pi/4$ - QPSK MODULATION)

1. CHANNEL: LOWEST

Frequency (GHz)	Level (dBm)	Limit (dBm)
1.39854	-30.86	-13.00

2. CHANNEL: MIDDLE

Frequency (GHz)	Level (dBm)	Limit (dBm)
1.41508	-30.4	-13.00

3. CHANNEL: HIGHEST

Frequency (GHz)	Level (dBm)	Limit (dBm)
1.43161	-29.62	-13.00

Measurement uncertainty (dB): $< \pm 2.76$

Verdict: PASS

NBLoT Band 13 (1 Tone 3.75 kHz. $\pi/2$ - BPSK MODULATION)

1. CHANNEL: LOWEST

Frequency (MHz)	Level (dBm)	Limit (dBm)
774.999	-50.65	-35

2. CHANNEL: MIDDLE

No spurious signals were found at less than 20dB respect to the limit in all the range.

3. CHANNEL: HIGHEST

No spurious signals were found at less than 20dB respect to the limit in all the range.

NBLoT Band 13 (Tone 15 kHz. $\pi/4$ - QPSK MODULATION)

1. CHANNEL: LOWEST

No spurious signals were found at less than 20dB respect to the limit in all the range.

2. CHANNEL: MIDDLE

No spurious signals were found at less than 20dB respect to the limit in all the range.

3. CHANNEL: HIGHEST

No spurious signals were found at less than 20dB respect to the limit in all the range.

Measurement uncertainty (dB): $< \pm 2.76$

Verdict: PASS

NBLoT Band 66 (1 Tone 3.75 kHz. $\pi/2$ - BPSK MODULATION)

1. CHANNEL: LOWEST

No spurious signals were found in all the range.

2. CHANNEL: MIDDLE

No spurious signals were found in all the range.

3. CHANNEL: HIGHEST

No spurious signals were found in all the range.

NBLoT Band 66 (Tone 15 kHz. $\pi/4$ - QPSK MODULATION)

1. CHANNEL: LOWEST

No spurious signals were found in all the range.

2. CHANNEL: MIDDLE

No spurious signals were found in all the range.

3. CHANNEL: HIGHEST

No spurious signals were found in all the range.

Measurement uncertainty (dB): $< \pm 2.76$

Verdict: PASS

NBLoT Band 85 (1 Tone 3.75 kHz. $\pi/2$ - BPSK MODULATION)

1. CHANNEL: LOWEST

No spurious signals were found at less than 20dB respect to the limit in all the range.

2. CHANNEL: MIDDLE

No spurious signals were found at less than 20dB respect to the limit in all the range.

3. CHANNEL: HIGHEST

No spurious signals were found at less than 20dB respect to the limit in all the range.

NBLoT Band 85 (Tone 15 kHz. $\pi/4$ - QPSK MODULATION)

1. CHANNEL: LOWEST

No spurious signals were found at less than 20dB respect to the limit in all the range.

2. CHANNEL: MIDDLE

No spurious signals were found at less than 20dB respect to the limit in all the range.

3. CHANNEL: HIGHEST

No spurious signals were found at less than 20dB respect to the limit in all the range.

Measurement uncertainty (dB): $< \pm 2.76$

Verdict: PASS

NBLoT Band 12 (1 Tone 3.75 kHz. $\pi/2$ - BPSK MODULATION)

1. CHANNEL: LOWEST

Frequency Range 9 kHz – 8 GHz

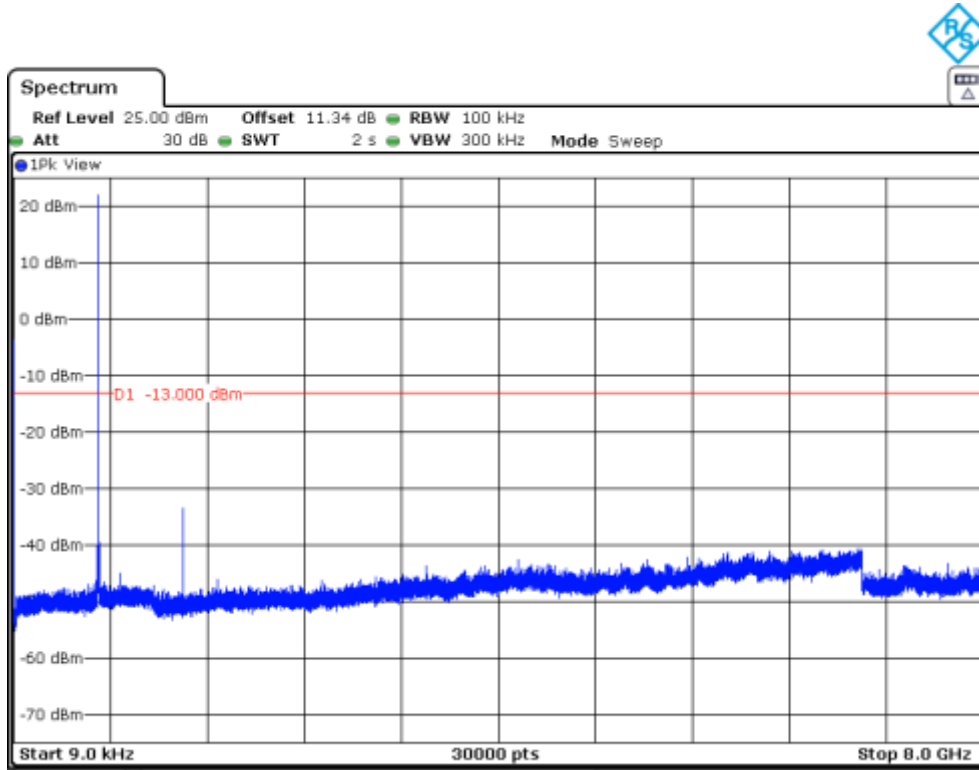

Note: The peak above the limit is the carrier frequency.

2. CHANNEL: MIDDLE

Frequency Range 9 kHz – 8 GHz

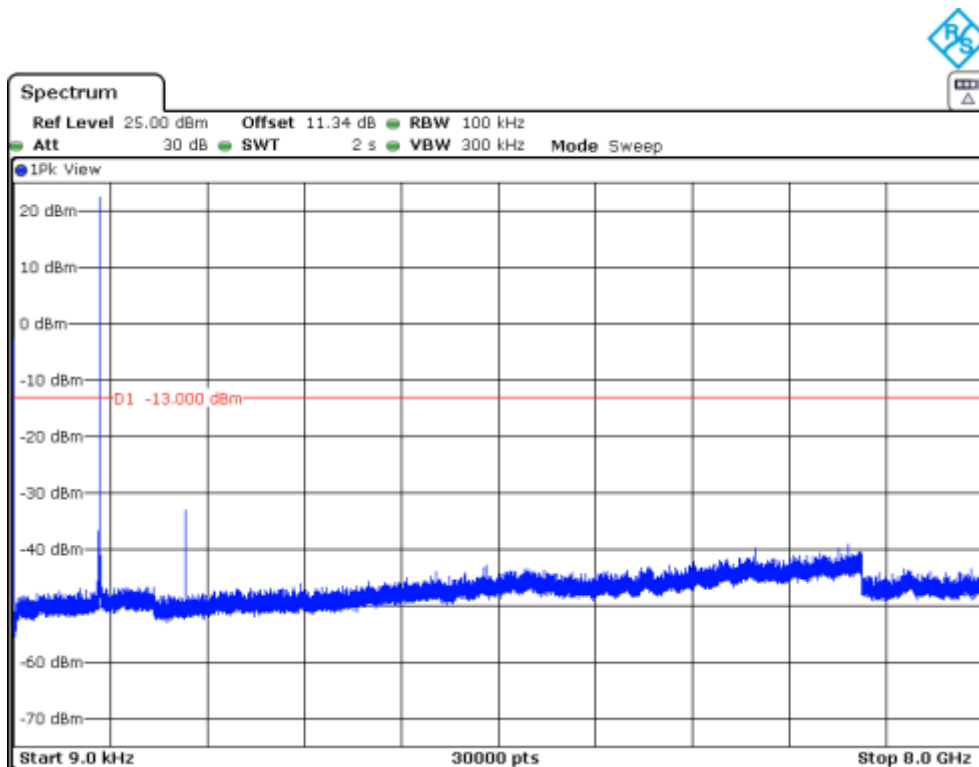

Note: The peak above the limit is the carrier frequency.

3. CHANNEL: HIGHEST

Frequency Range 9 kHz – 8 GHz

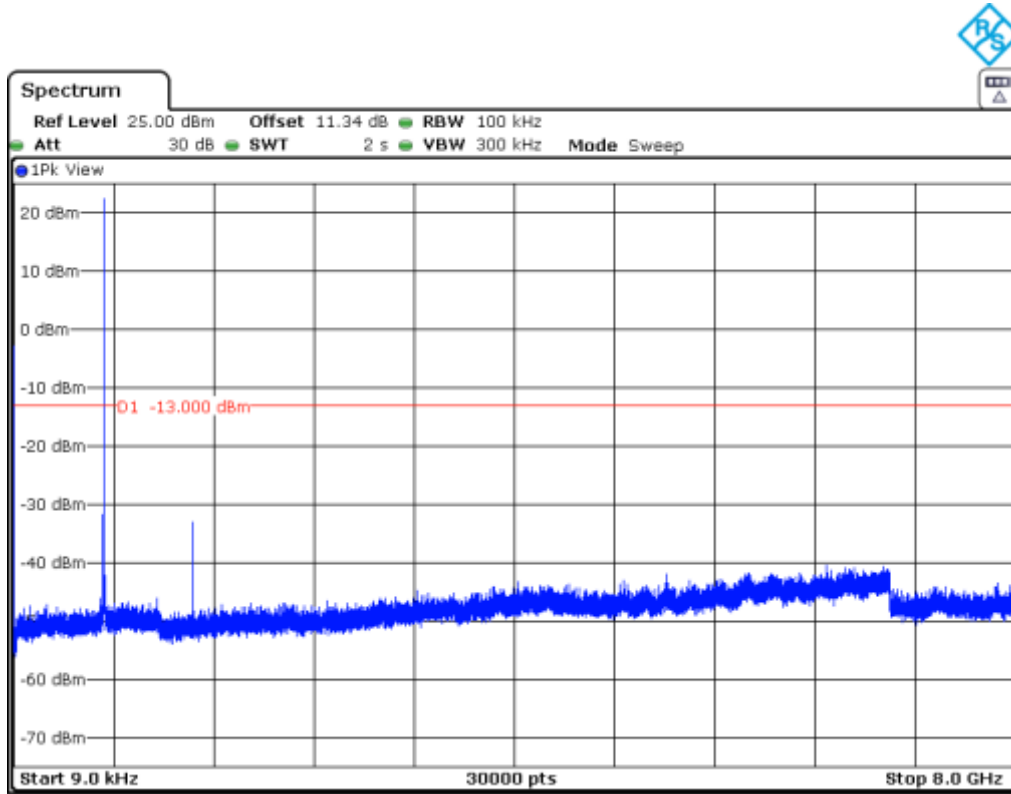

Note: The peak above the limit is the carrier frequency.

NBLoT Band 12 (3 Tones 15 kHz. $\pi/4$ - QPSK MODULATION)

1. CHANNEL: LOWEST

Frequency Range 9 kHz – 8 GHz

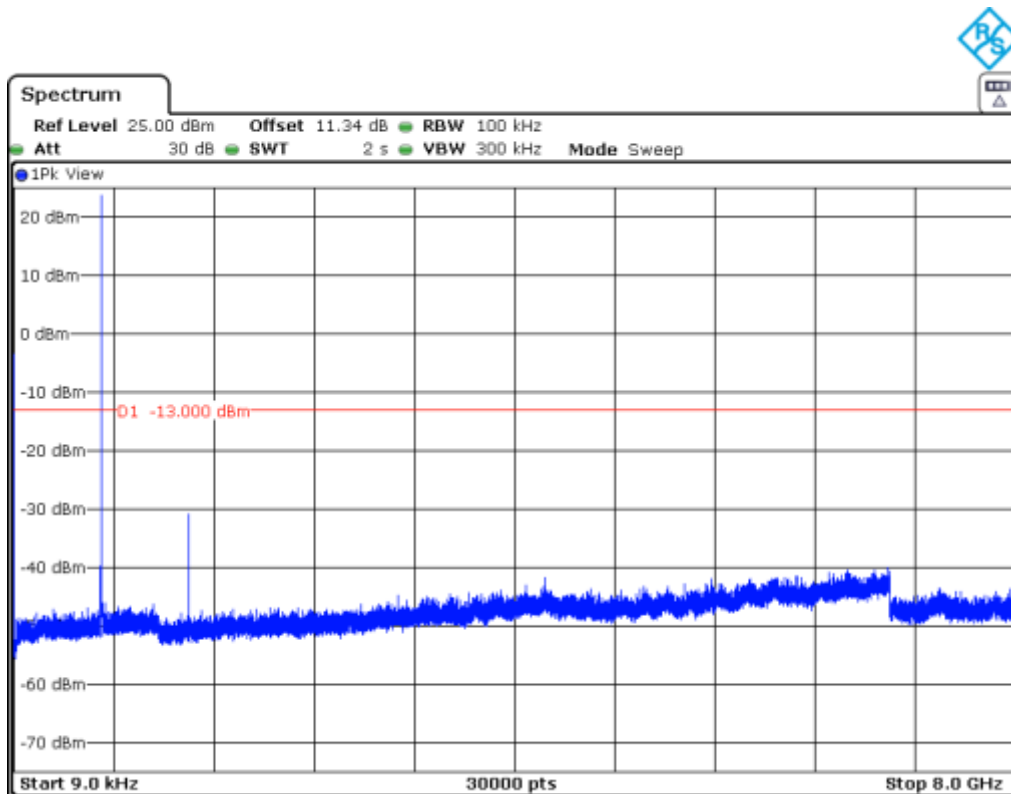

2. CHANNEL: MIDDLE

Frequency Range 9 kHz – 8 GHz

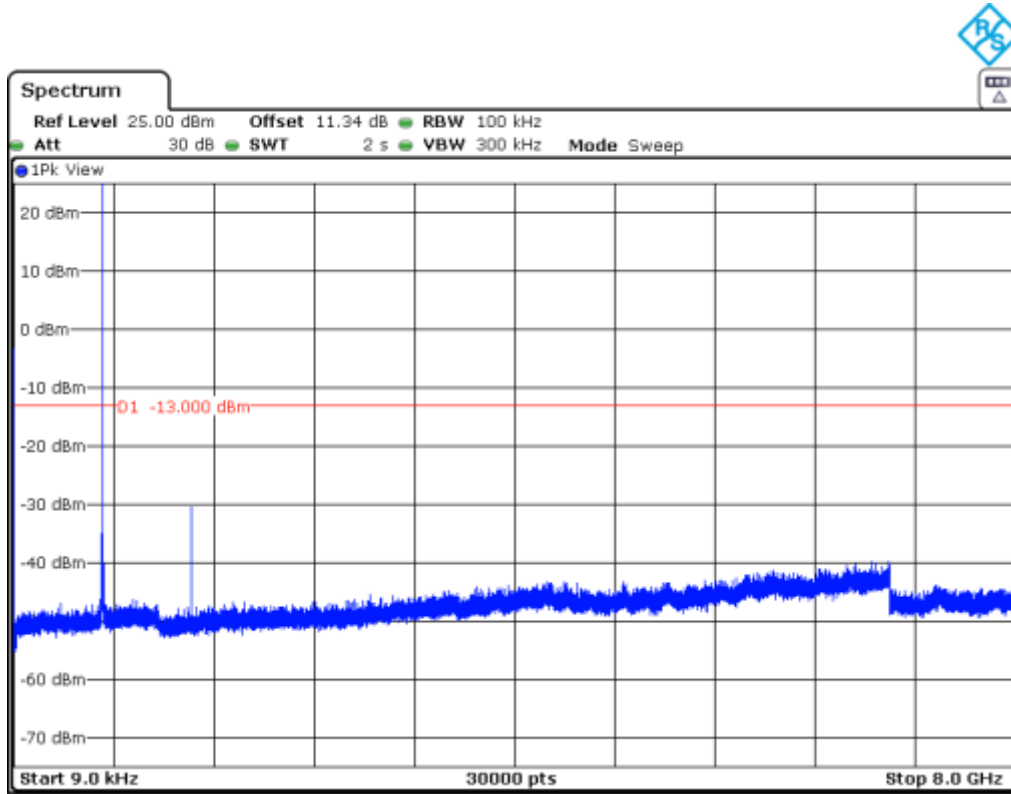

3. CHANNEL: HIGHEST

Frequency Range 9 kHz – 8 GHz

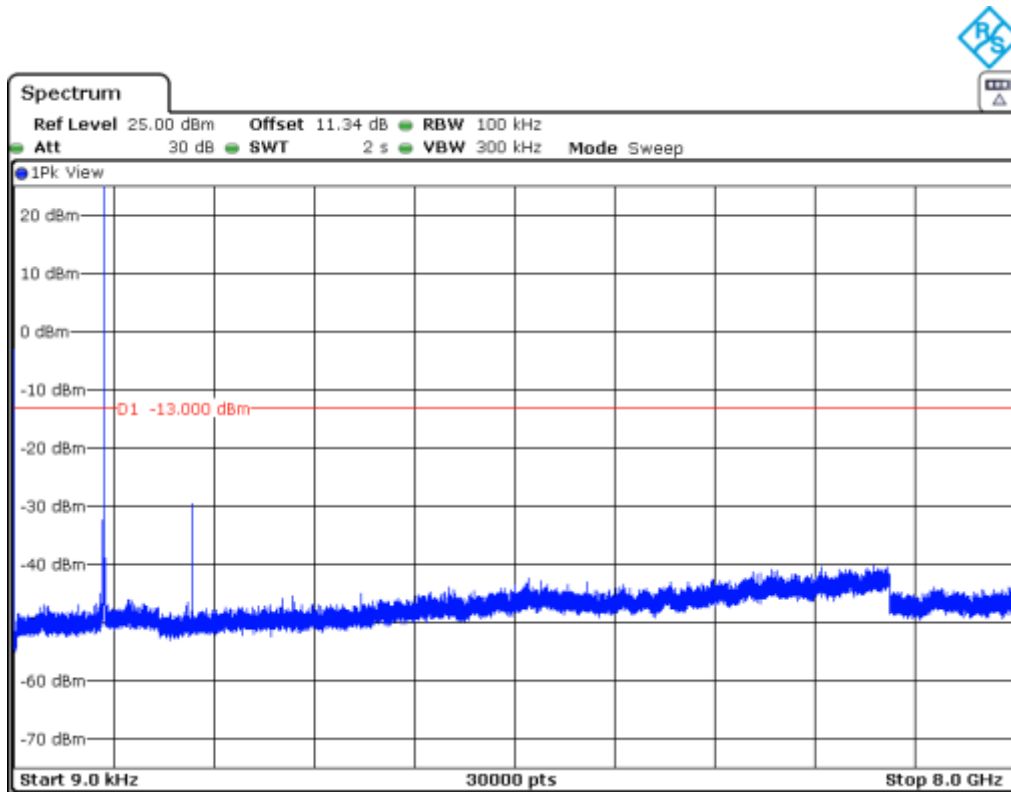

NBLoT Band 13 (1 Tone 3.75 kHz. $\pi/2$ - BPSK MODULATION)

1. CHANNEL: LOWEST

Frequency Range 9 kHz – 8 GHz

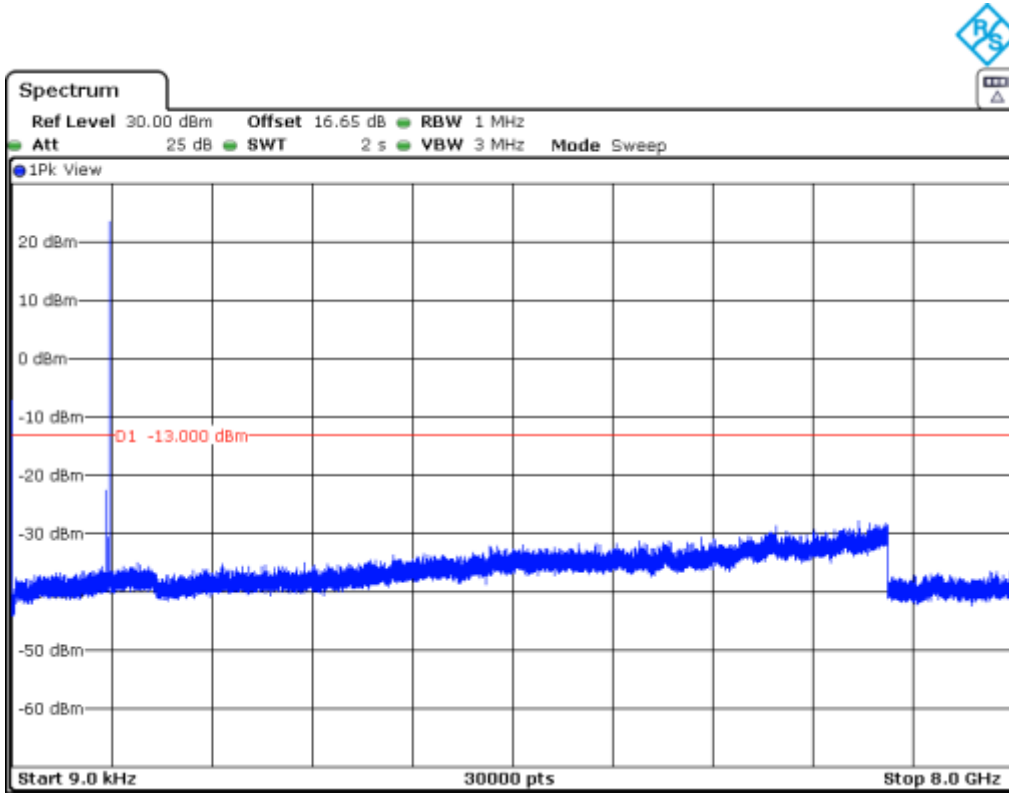

Note: The peak above the limit is the carrier frequency. The peak at 746MHz corresponds to the downlink signal.

Frequency Range 763 MHz - 775 MHz

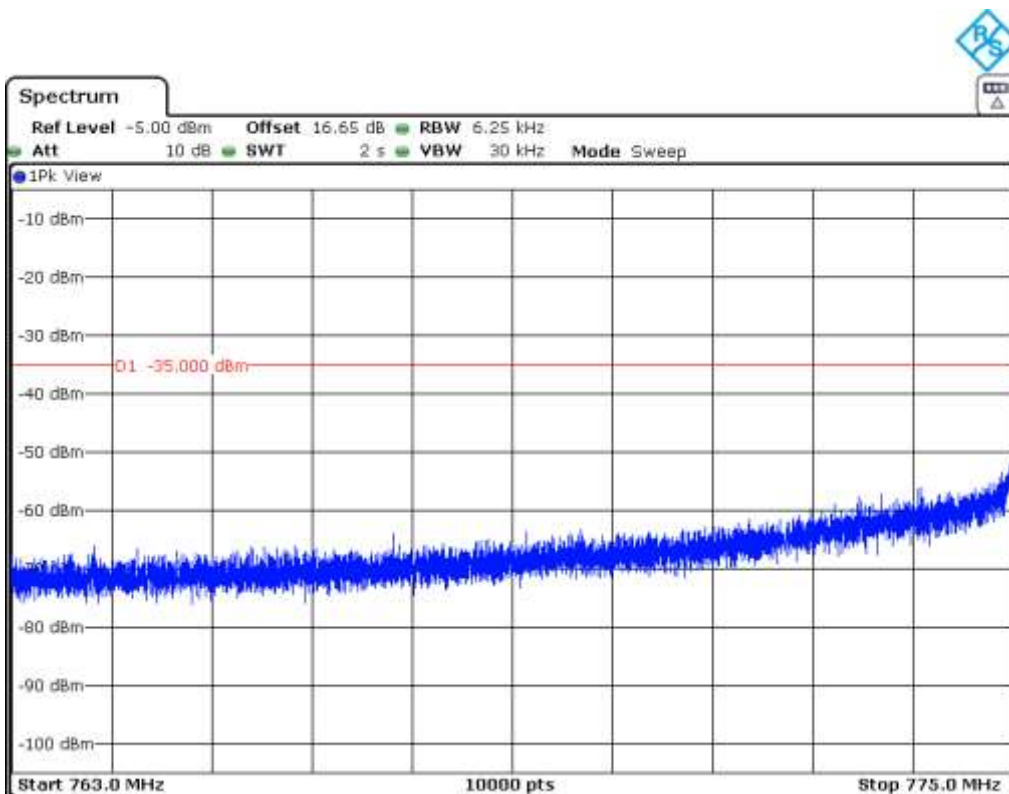

Frequency Range 793 MHz - 806 MHz

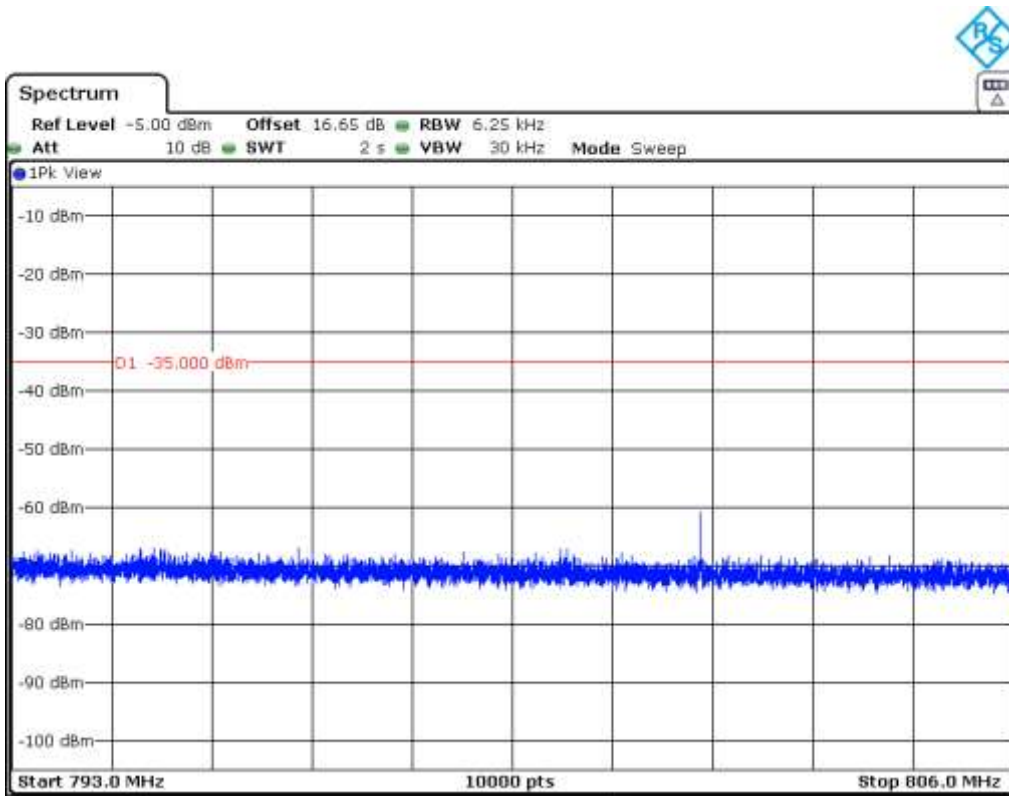

2. CHANNEL: MIDDLE

Frequency Range 9 kHz – 8 GHz

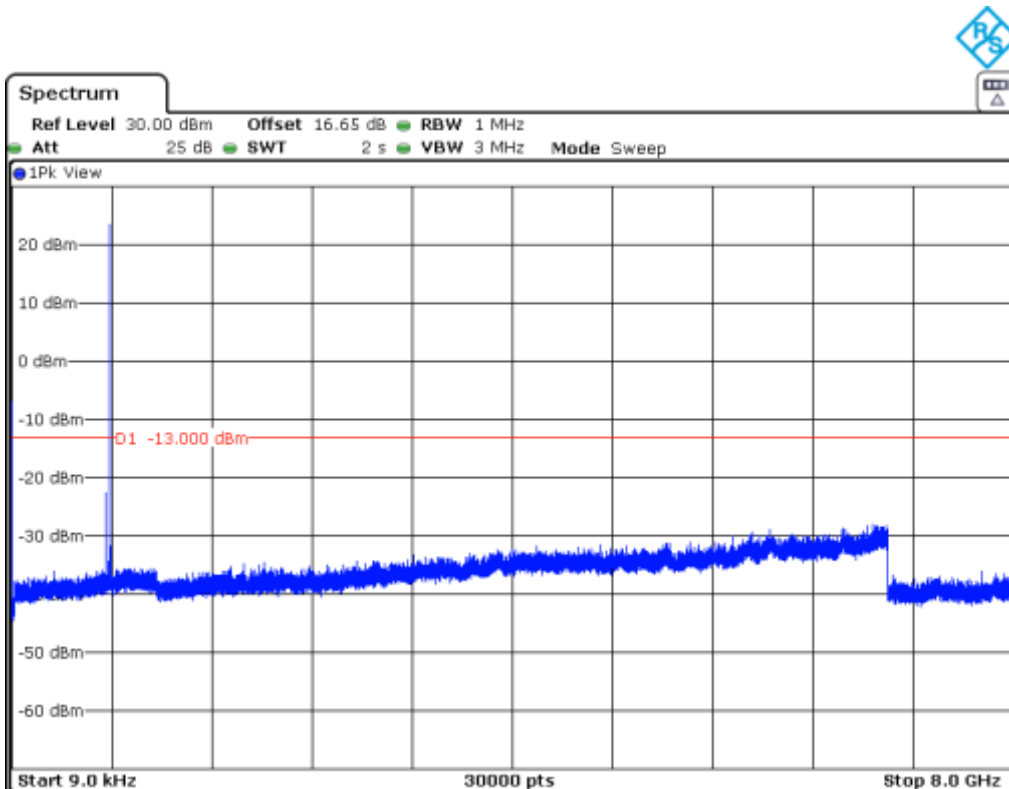

Note: The peak above the limit is the carrier frequency. The peak at 751MHz corresponds to the downlink signal.

Frequency Range 763 MHz - 775 MHz

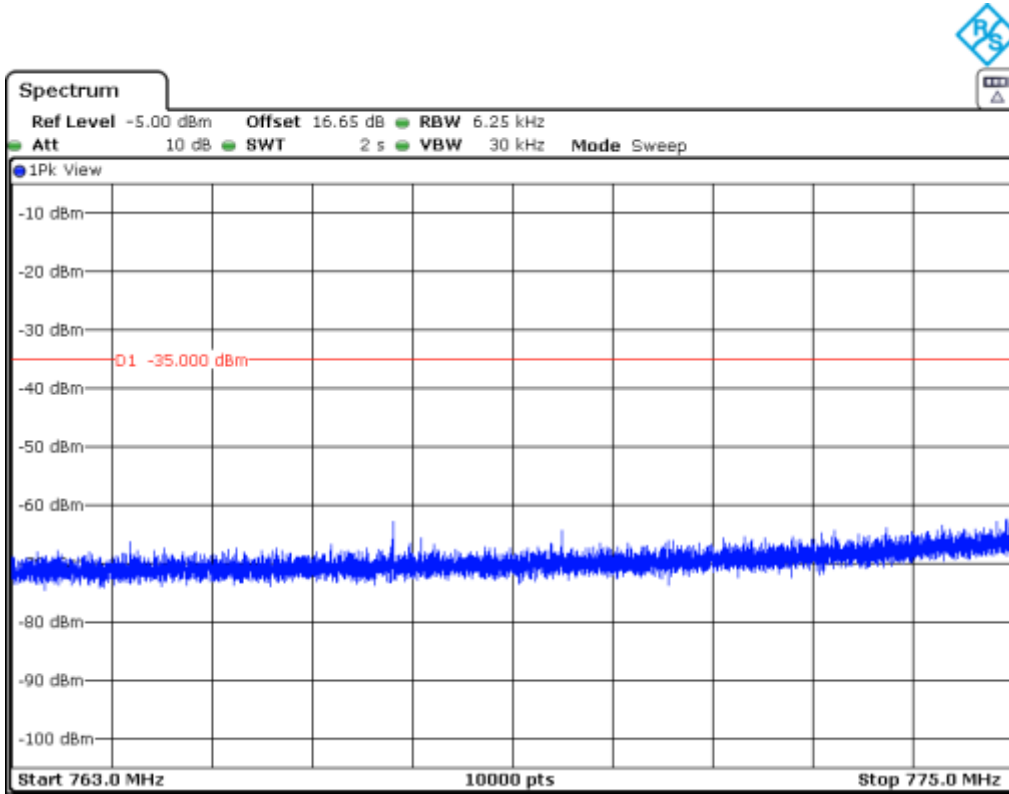

Frequency Range 793 MHz - 806 MHz

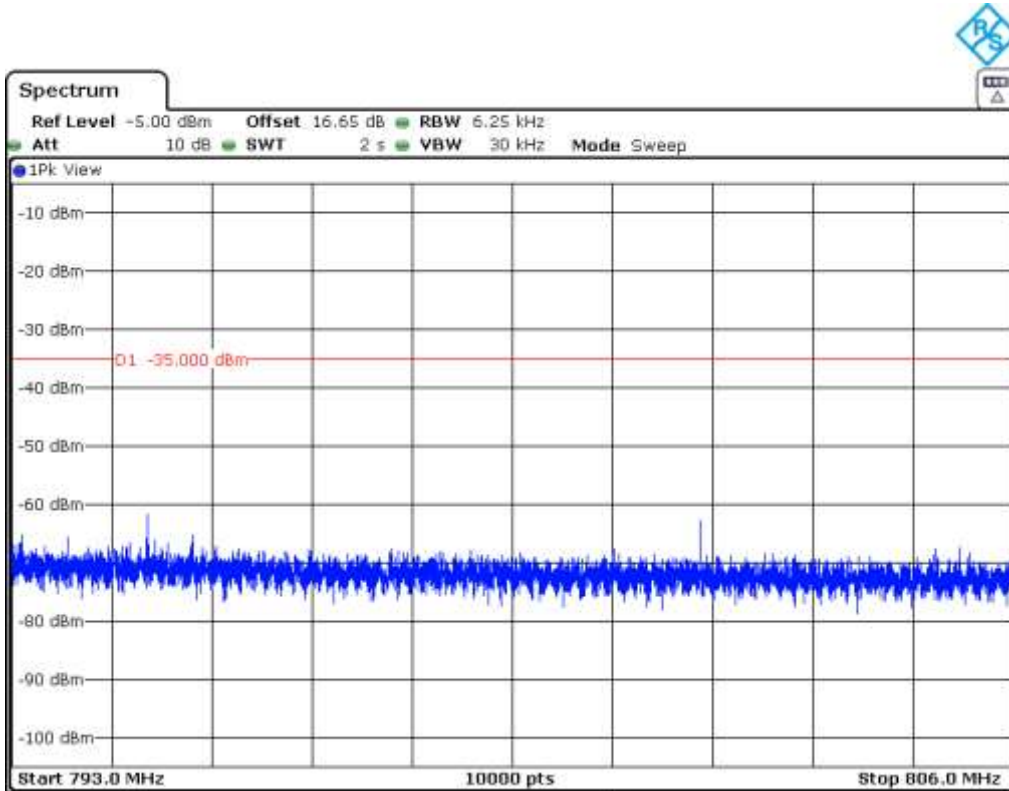

3. CHANNEL: HIGHEST

Frequency Range 9 kHz – 8 GHz

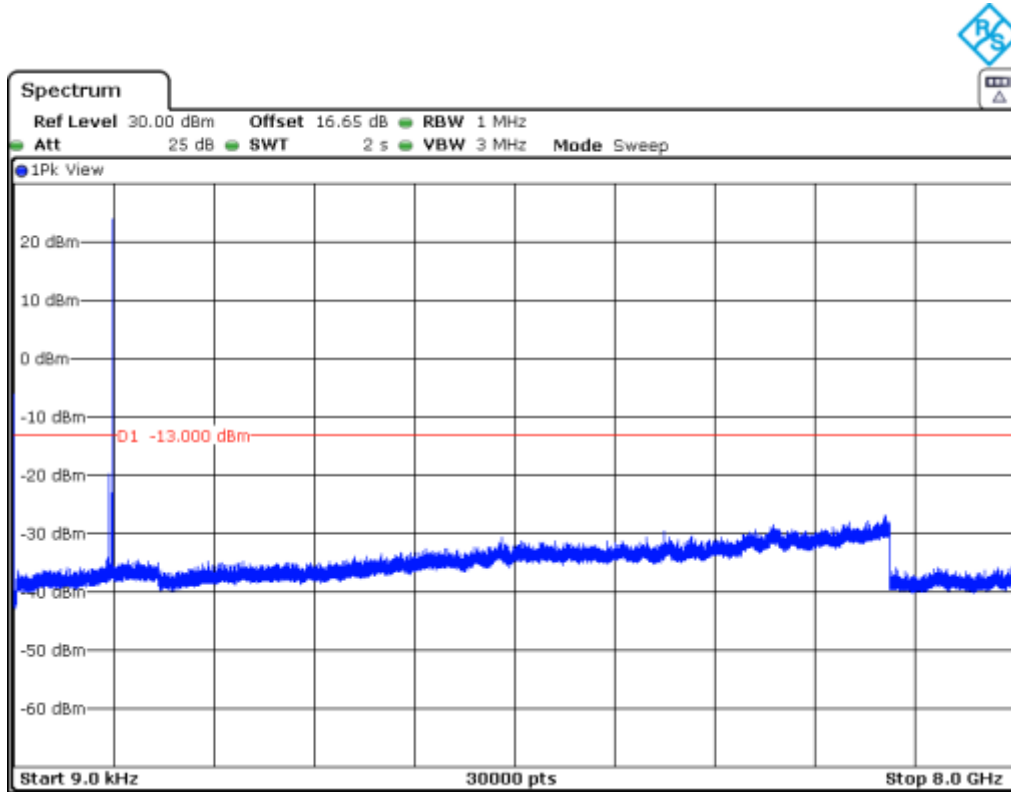

Note: The peak above the limit is the carrier frequency. The peak at 756MHz corresponds to the downlink signal.

Frequency Range 763 MHz - 775 MHz

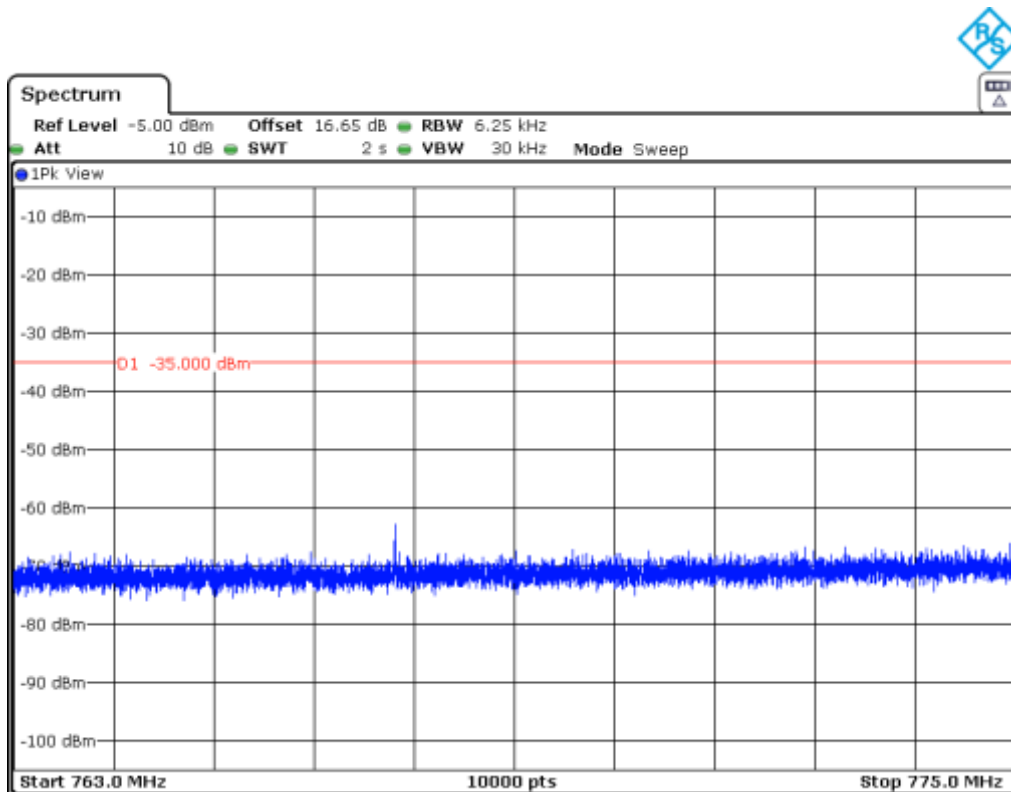

Frequency Range 793 MHz - 806 MHz

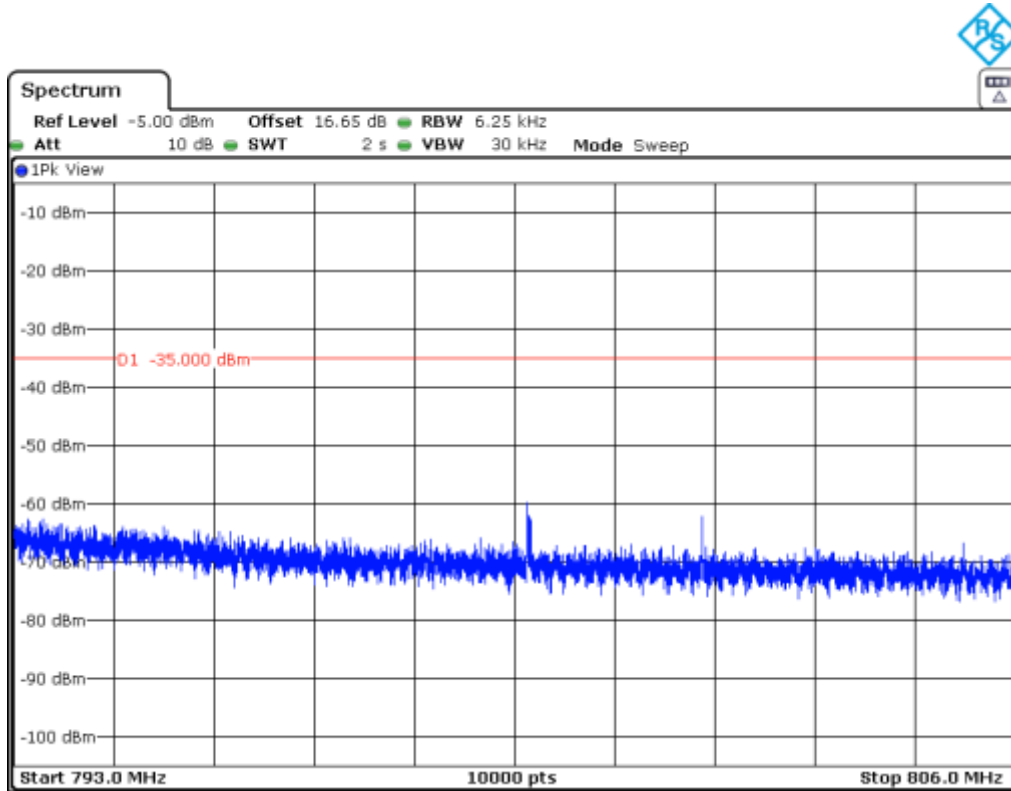

NBLoT Band 13 (1 Tone 15 kHz. $\pi/4$ - QPSK MODULATION)

1. CHANNEL: LOWEST

Frequency Range 9 kHz – 8 GHz

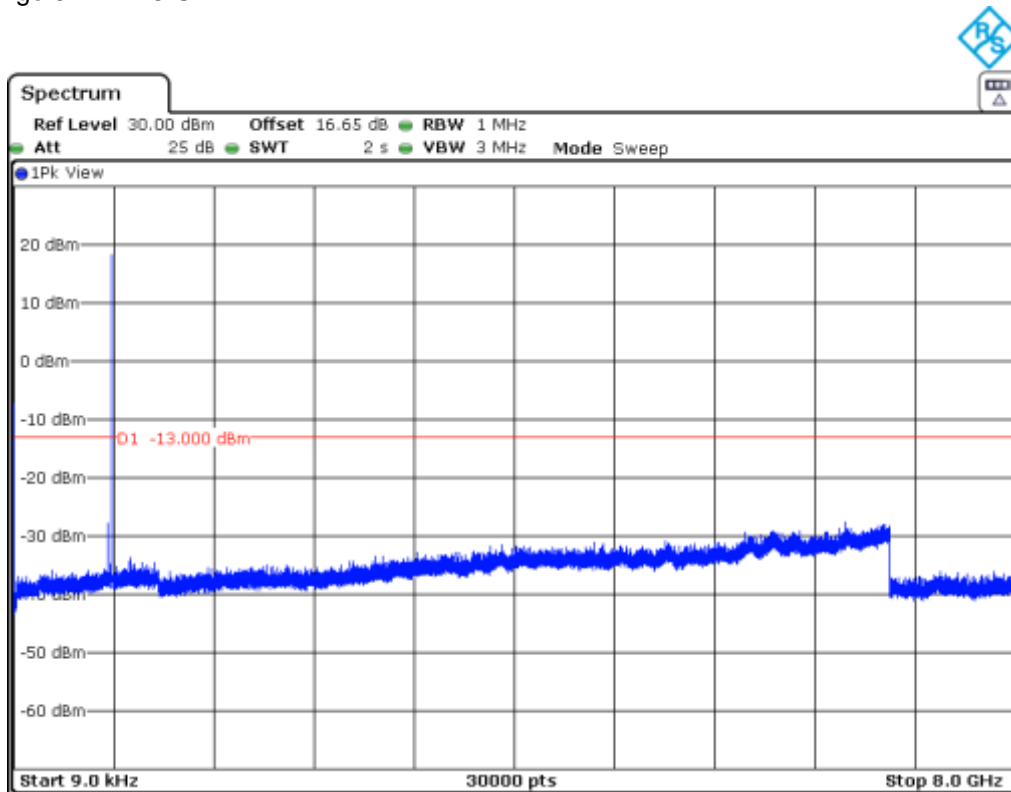

Note: The peak above the limit is the carrier frequency. The peak at 746MHz corresponds to the downlink signal.

Frequency Range 763 MHz - 775 MHz

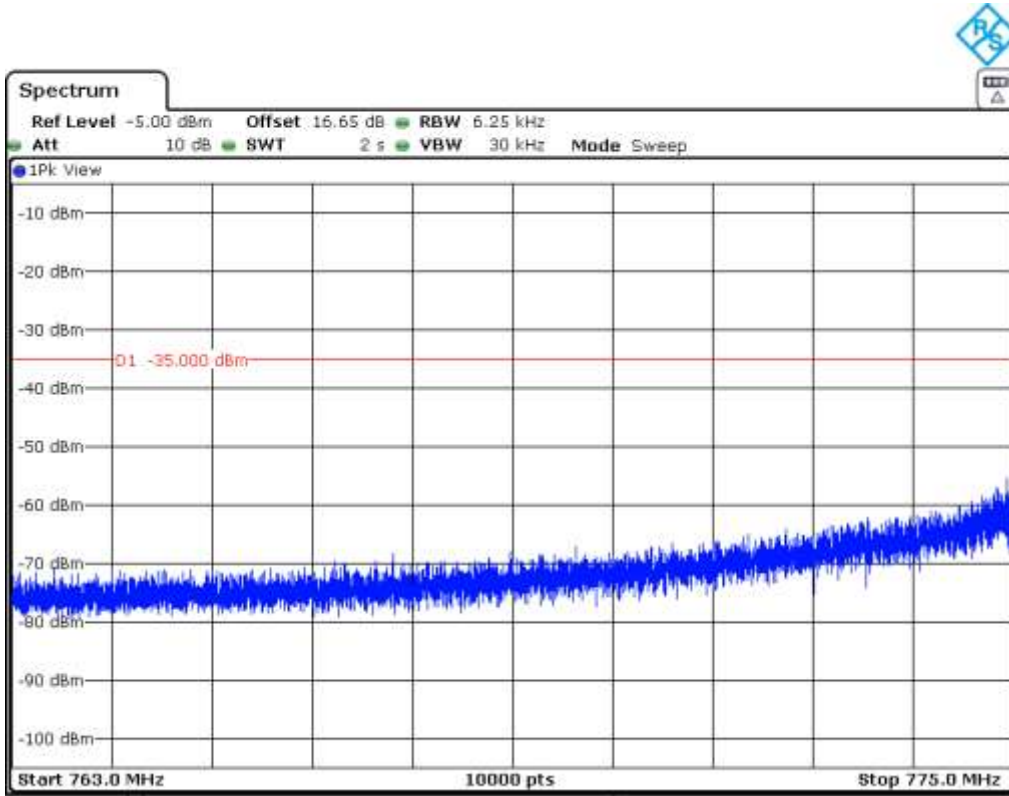

Frequency Range 793 MHz - 806 MHz

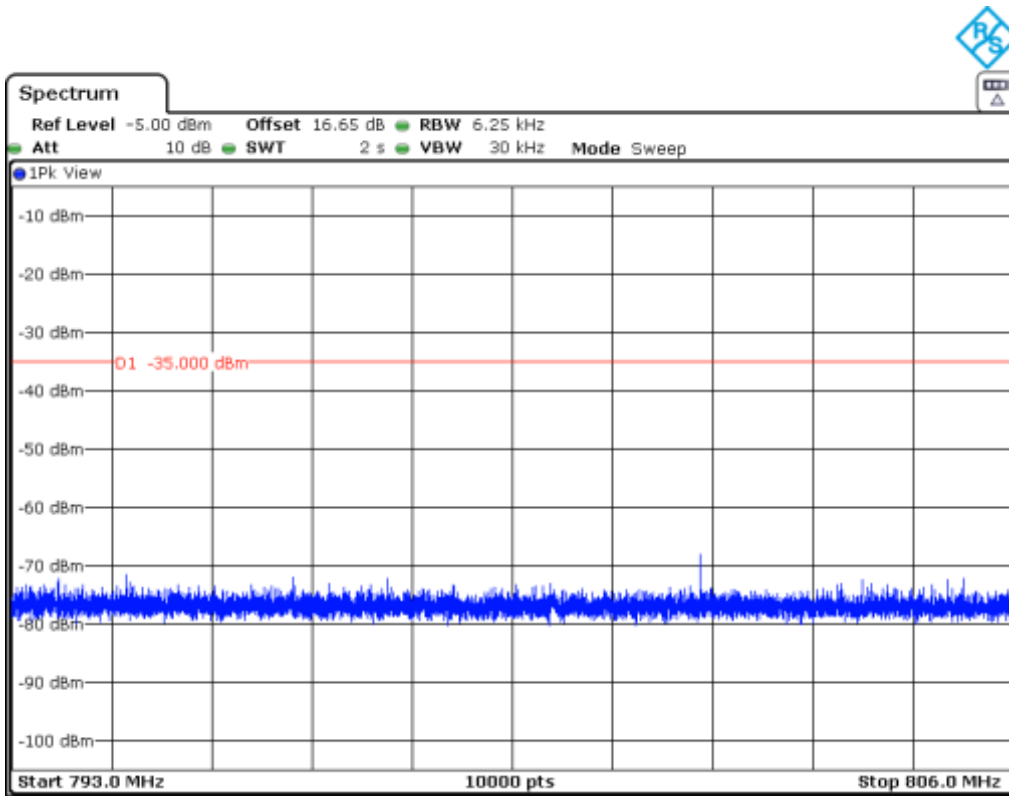

2. CHANNEL: MIDDLE

Frequency Range 9 kHz – 8 GHz

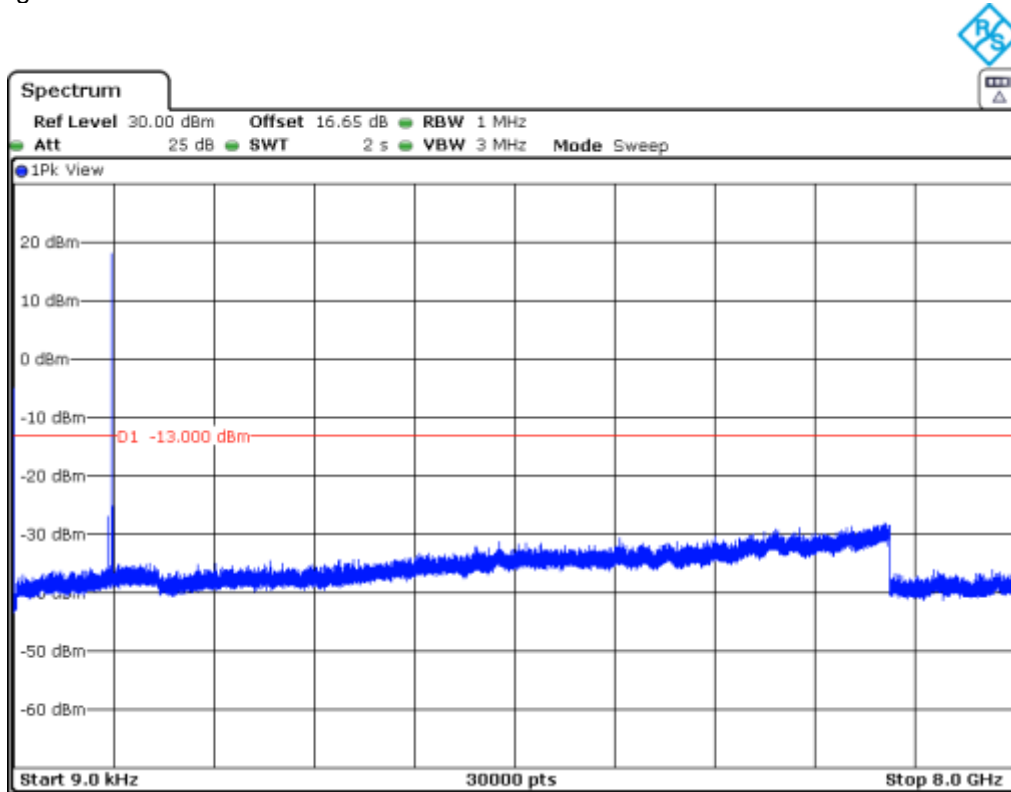

Note: The peak above the limit is the carrier frequency. The peak at 751MHz corresponds to the downlink signal.

Frequency Range 763 MHz - 775 MHz

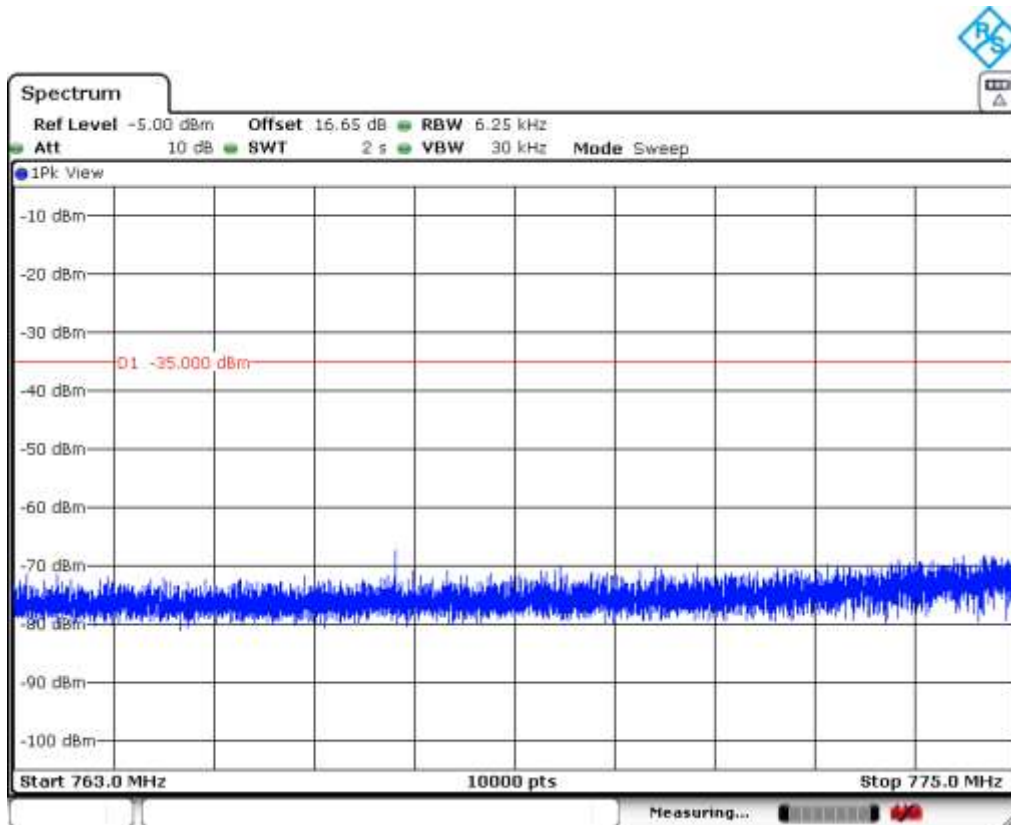

Frequency Range 793 MHz - 806 MHz

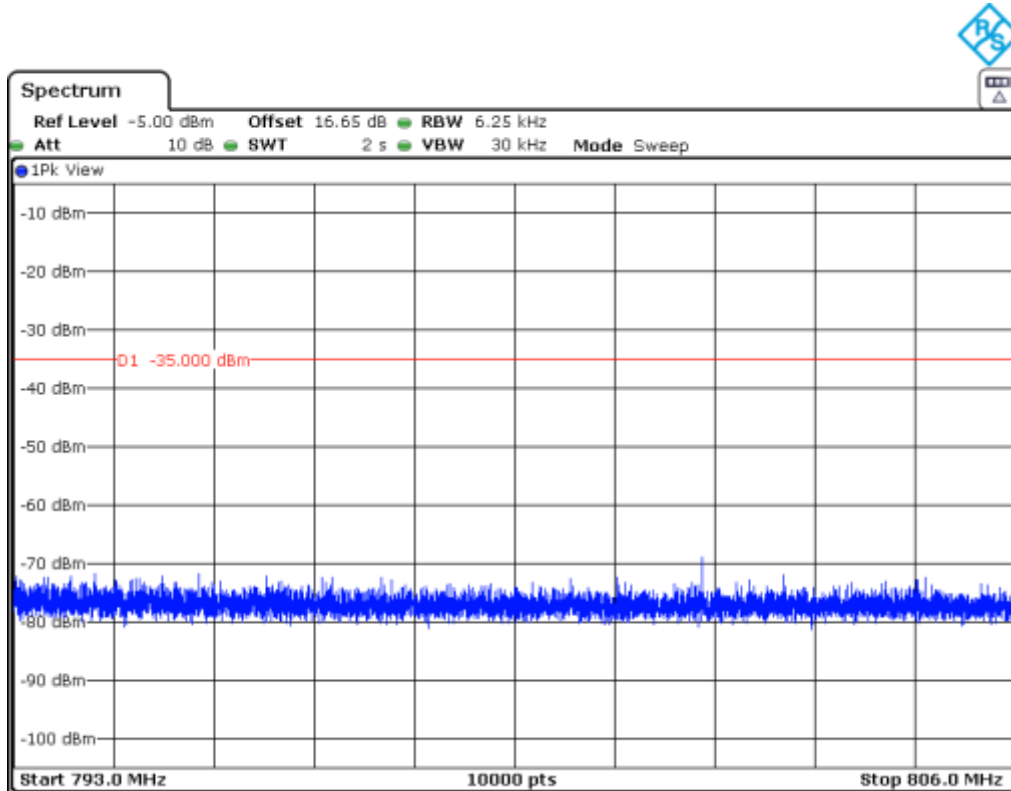

3. CHANNEL: HIGHEST

Frequency Range 9 kHz – 8 GHz

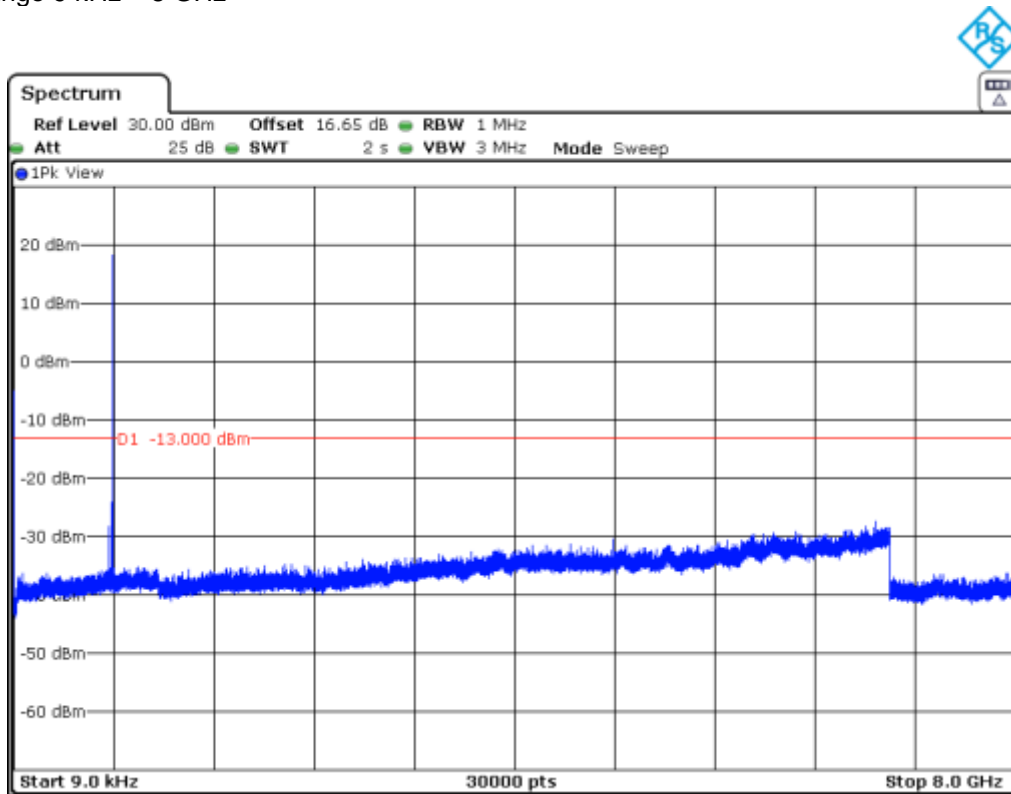

Note: The peak above the limit is the carrier frequency. The peak at 756MHz corresponds to the downlink signal.

Frequency Range 763 MHz - 775 MHz

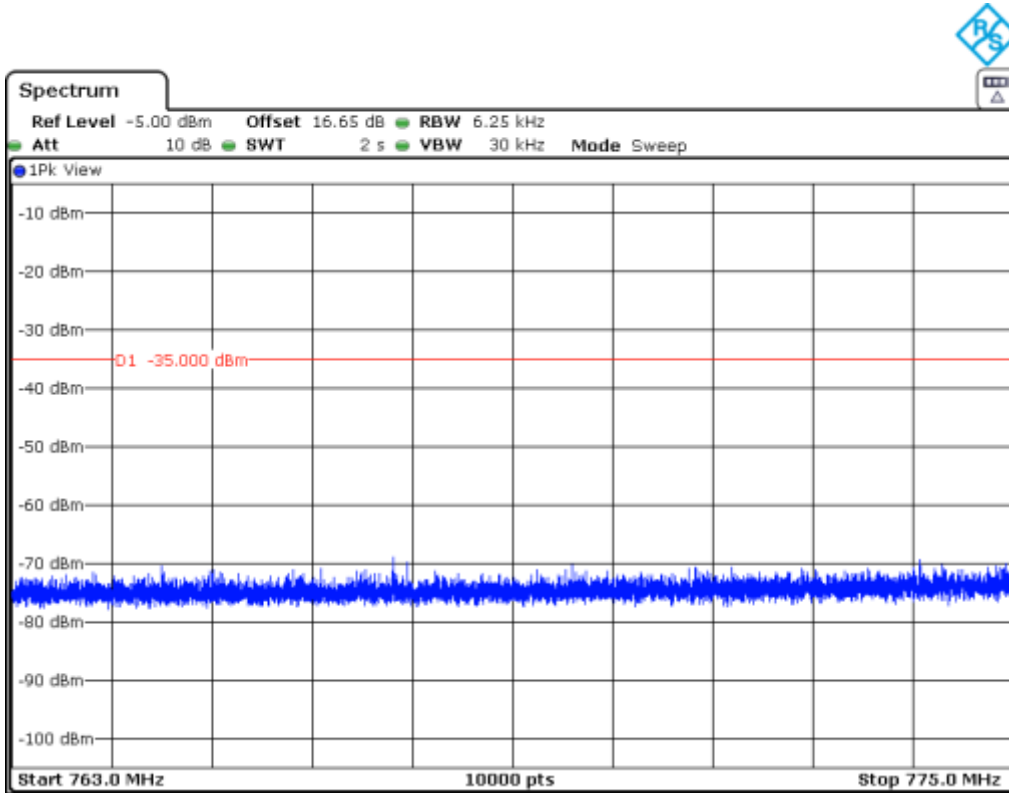

Frequency Range 793 MHz - 806 MHz

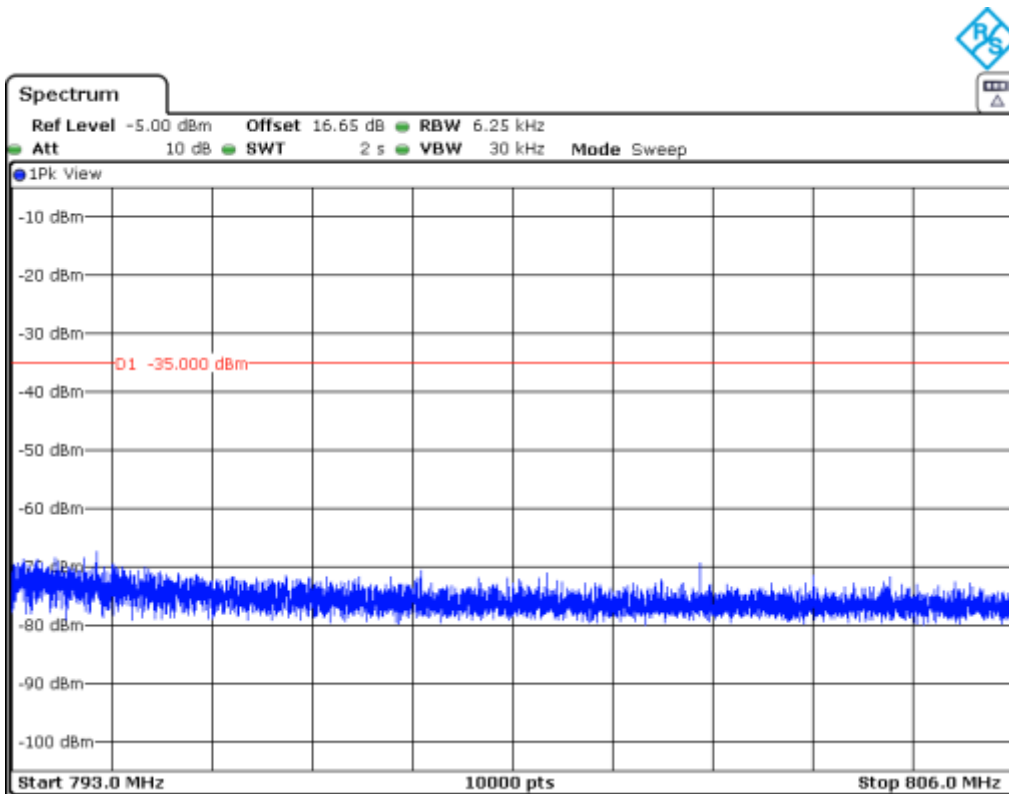

NBLoT Band 66(1 Tone 3.75 kHz. $\pi/2$ - BPSK MODULATION)

1. CHANNEL: LOWEST

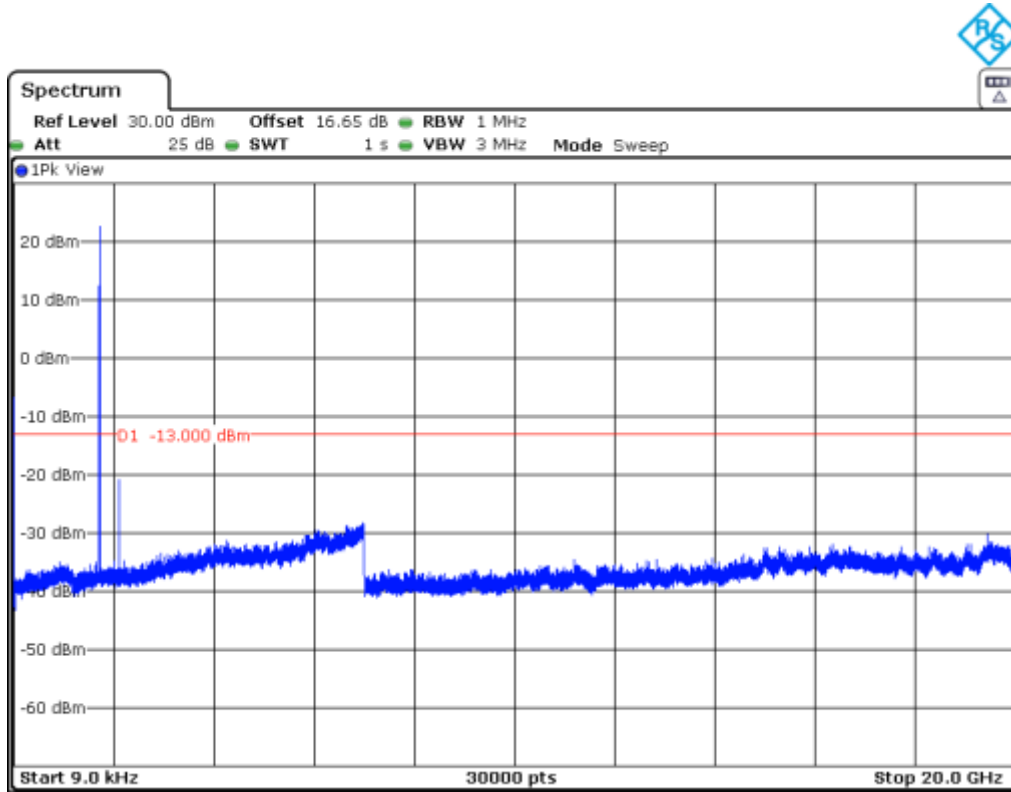

Note: The peak above the limit is the carrier frequency. The peak at 1805MHz corresponds to the downlink signal.

2. CHANNEL: MIDDLE

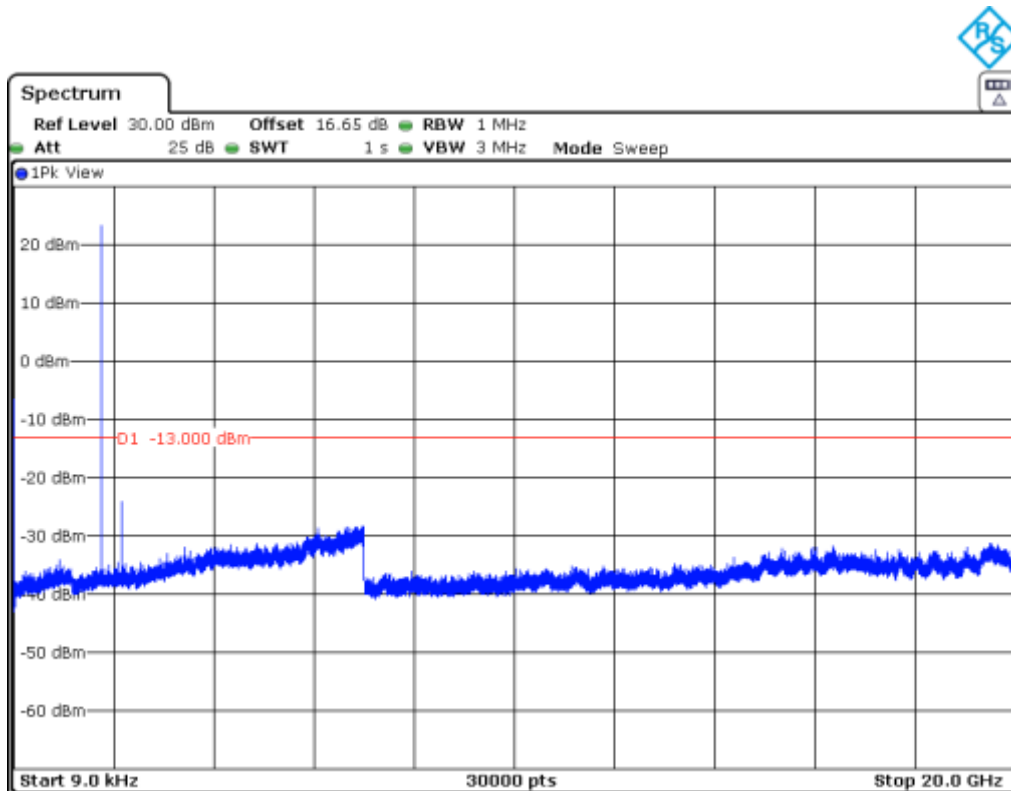

Note: The peak above the limit is the carrier frequency. The peak at 1840MHz corresponds to the downlink signal.

3. CHANNEL: HIGHEST

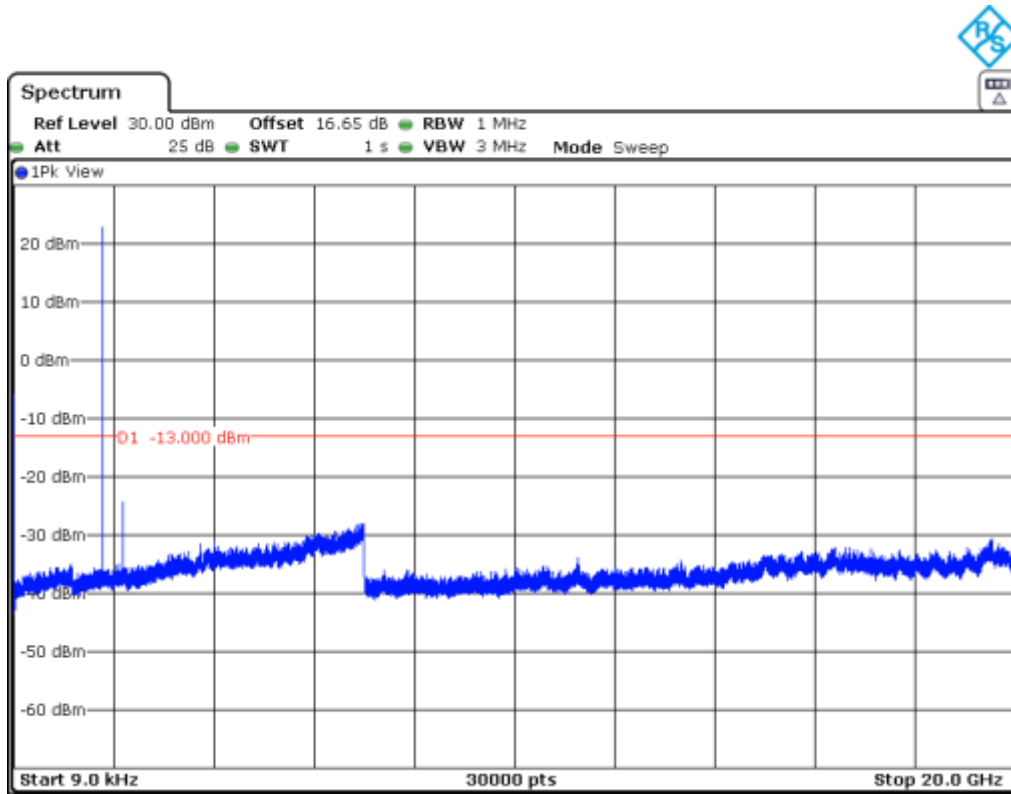

Note: The peak above the limit is the carrier frequency. The peak at 1875MHz corresponds to the downlink signal.

NB-IoT Band 66(1 Tone 15 kHz. $\pi/4$ - QPSK MODULATION)

1. CHANNEL: LOWEST

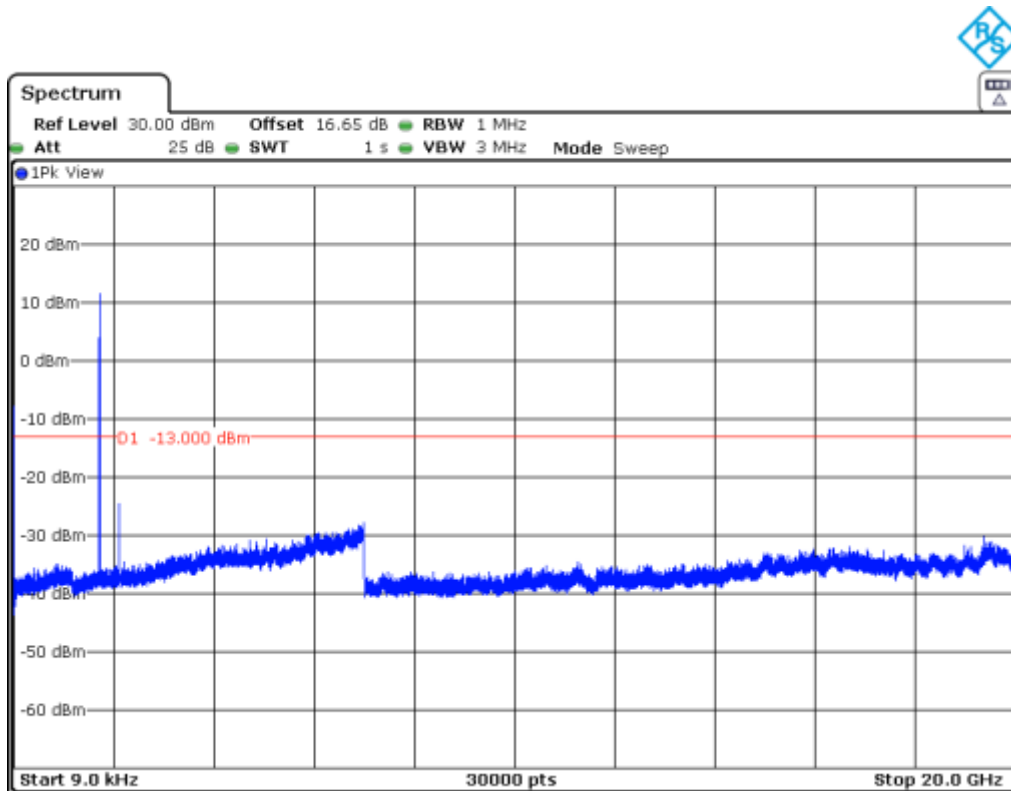

Note: The peak above the limit is the carrier frequency. The peak at 1805MHz corresponds to the downlink signal.

2. CHANNEL: MIDDLE

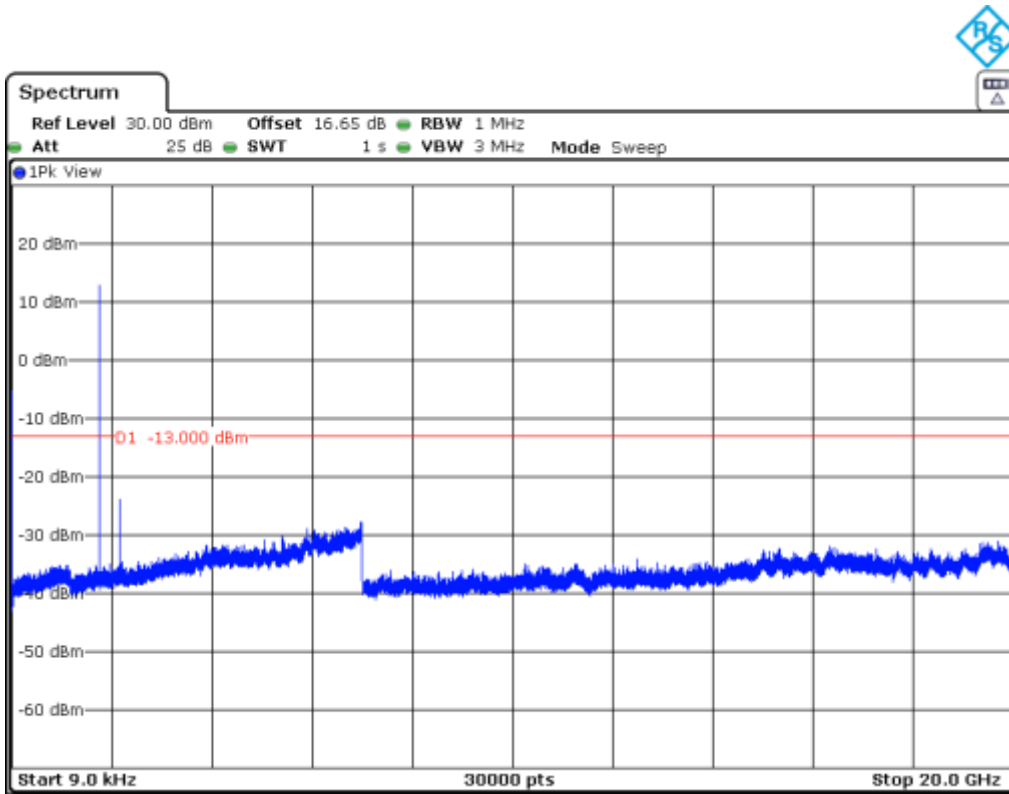

Note: The peak above the limit is the carrier frequency. The peak at 1840MHz corresponds to the downlink signal.

3. CHANNEL: HIGHEST

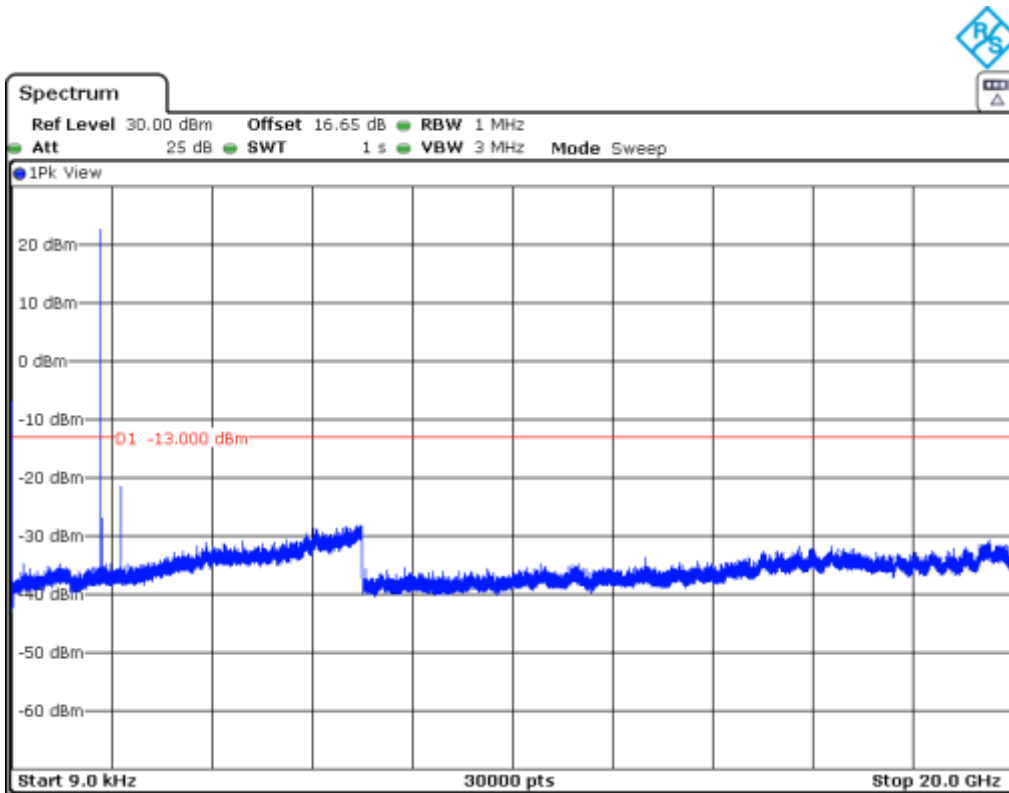

Note: The peak above the limit is the carrier frequency. The peak at 1875MHz corresponds to the downlink signal.

NBLoT Band 85 (1 Tone 3.75 kHz. $\pi/2$ - BPSK MODULATION)

1. CHANNEL: LOWEST

Frequency Range 9 kHz – 10 GHz

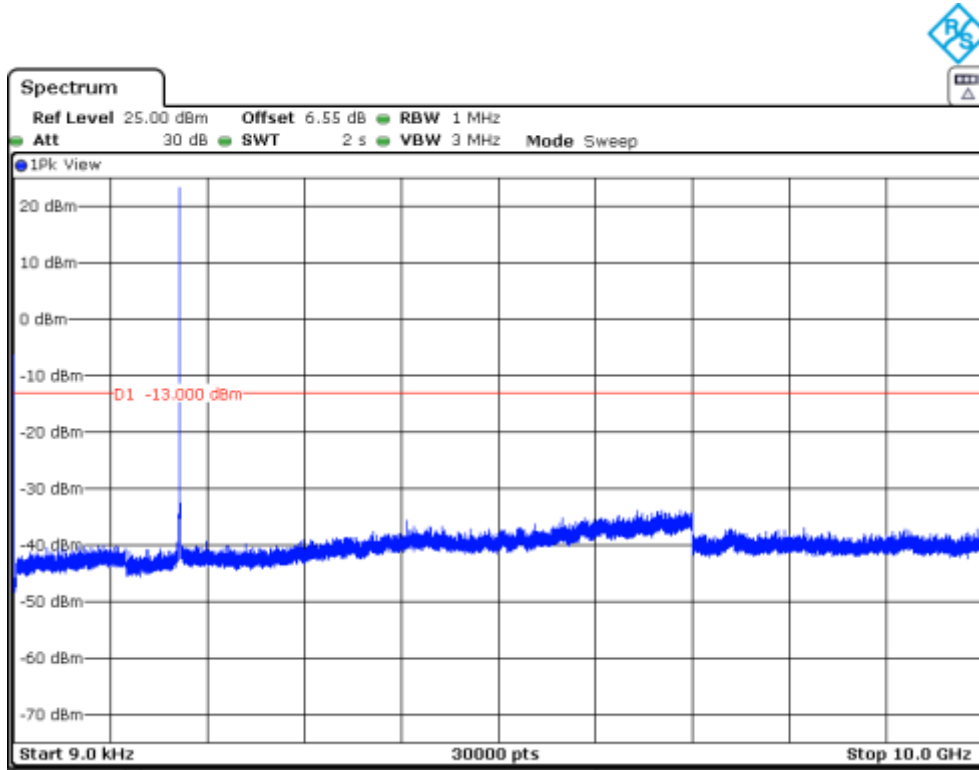

Note: The peak above the limit is the carrier frequency.

2. CHANNEL: MIDDLE

Frequency Range 9 kHz – 10 GHz

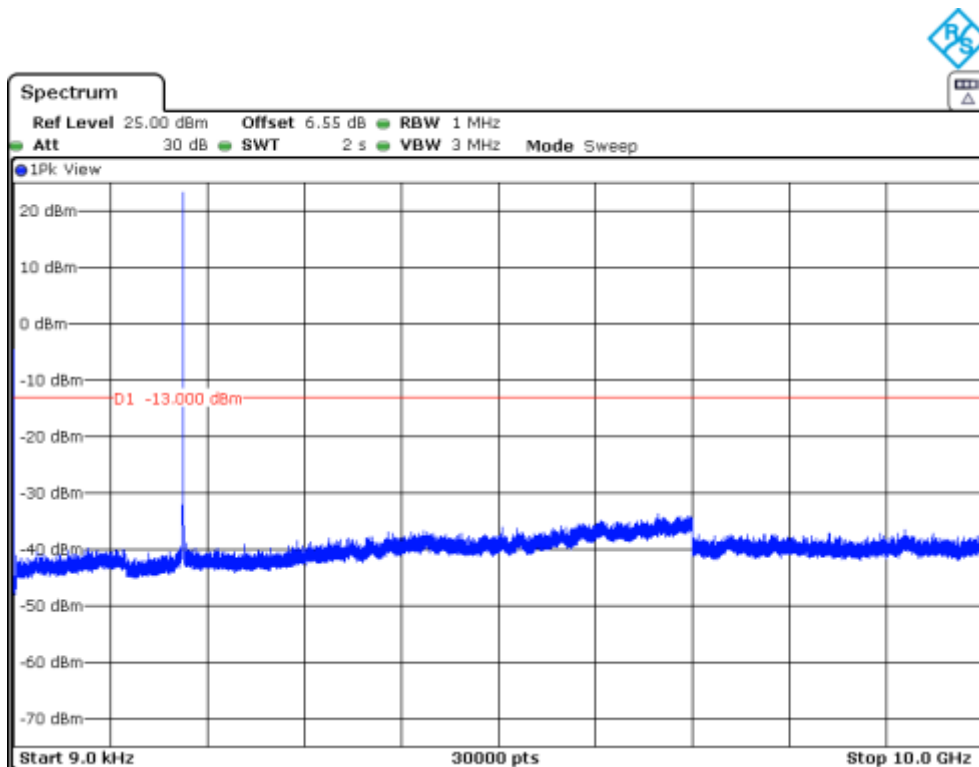

Note: The peak above the limit is the carrier frequency.

3. CHANNEL: HIGHEST

Frequency Range 9 kHz – 10 GHz

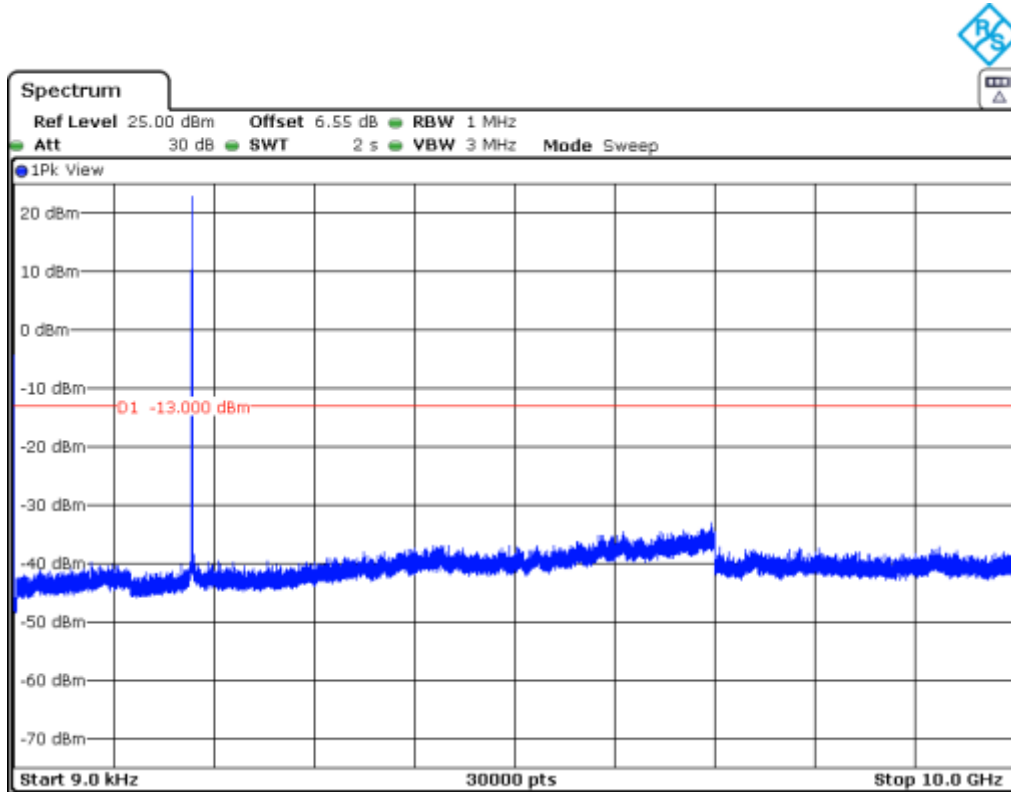

Note: The peak above the limit is the carrier frequency.

NB-IoT Band 85 (3 Tones 15 kHz. $\pi/4$ - QPSK MODULATION)

1. CHANNEL: LOWEST

Frequency Range 9 kHz – 10 GHz

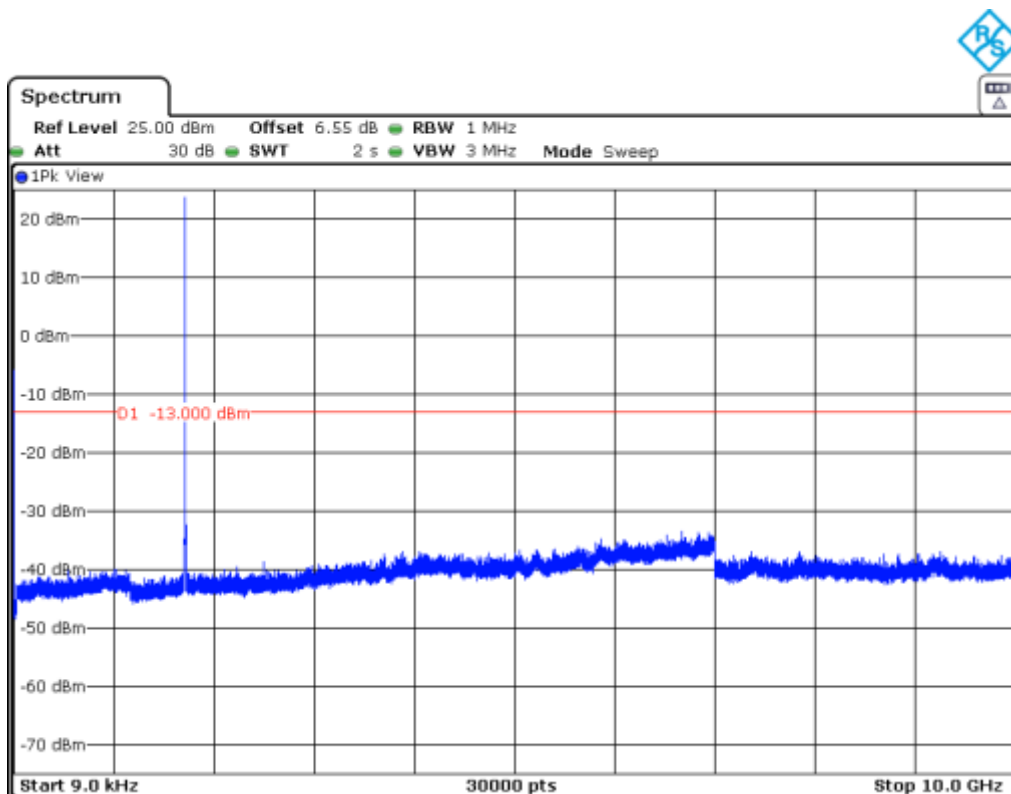

2. CHANNEL: MIDDLE

Frequency Range 9 kHz – 10 GHz

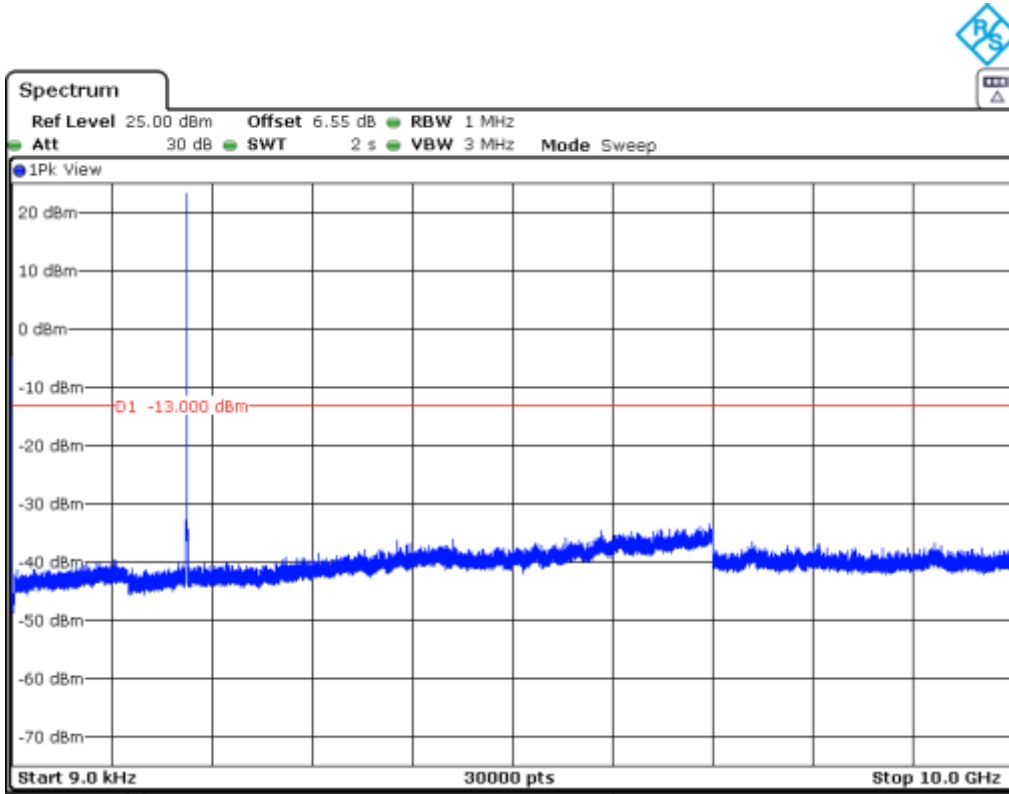

3. CHANNEL: HIGHEST

Frequency Range 9 kHz – 10 GHz

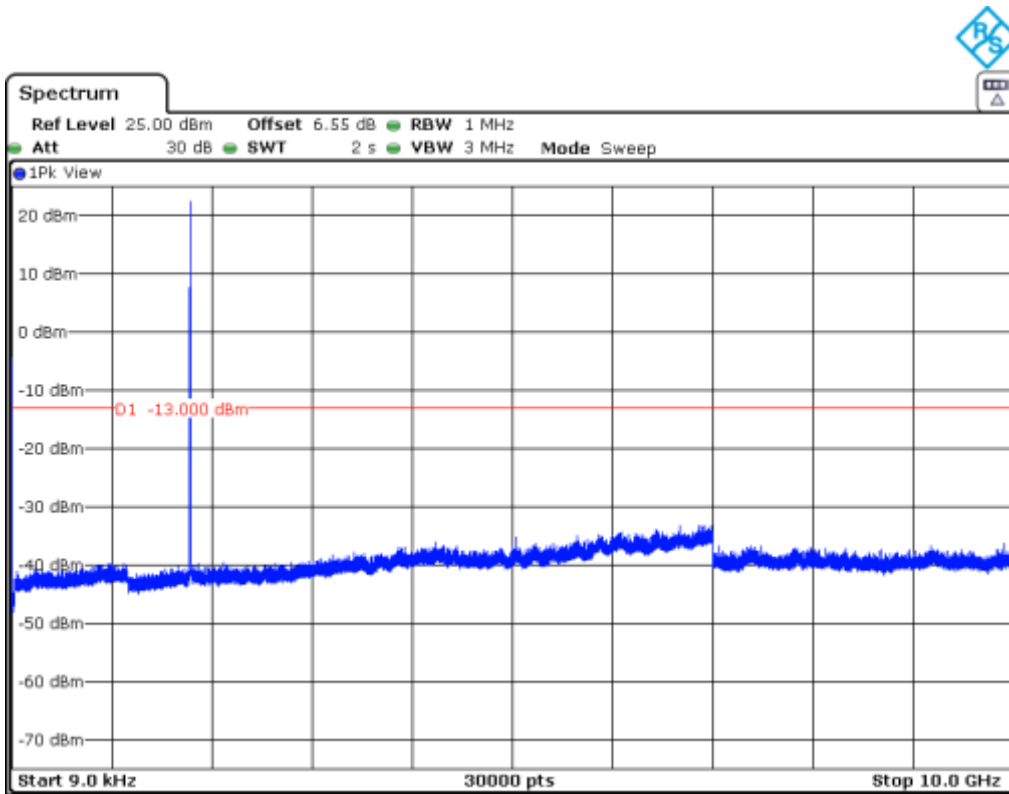

Spurious emissions at antenna terminals at Block Edges

SPECIFICATION

FCC §27.53 (c) & (g) & (h). RSS-130 Clause 4.7. RSS-139 Clause 6.6.

According to specification. the power of emissions shall be attenuated below the transmitter power (P) by a factor of at least $43 + 10 \log (P)$ dB. P in watts.

At P_o transmitting power. the specified minimum attenuation becomes $43+10\log (P_o)$. and the level in dBm relative P_o becomes:

$$P_o \text{ (dBm)} - [43 + 10 \log (P_o \text{ in mwatts}) - 30] = -13 \text{ dBm}$$

METHOD

The EUT RF output connector was connected to a spectrum analyser and to the Universal Radio Communication tester R&S CMW500 (selecting maximum transmission power of the EUT and different modes of modulation) using a 50 ohm attenuator and a power splitter.

The reading of the spectrum analyser is corrected with the attenuation loss of connection between output terminal of EUT and input of the spectrum analyser.

The configuration of modulation which is the worst case for conducted power was used.

For NBLoT Band12 and NBLoT85. as indicated in FCC part 27.53 (g) /RSS-130 Clause 4.7, in the 100 kHz bands immediately outside and adjacent to the licensee's frequency block or band. a resolution bandwidth of 30 kHz may be employed.

For NBLoT Band 13. as indicated in FCC part 27.53 (c) (5) /RSS-130 Clause 4.6., in the 100 kHz bands immediately outside and adjacent to the licensee's frequency block or band. a resolution bandwidth of 30 kHz may be employed.

For NBLoT Band 66. as indicated in FCC part 27.53 (h) (3) /RSS-139 Clause 6.6.. in the 1 MHz bands immediately outside and adjacent to the licensee's frequency block. a resolution bandwidth of at least one percent of the emission bandwidth/occupied bandwidth of the fundamental emission of the transmitter may be employed.

TEST SETUP

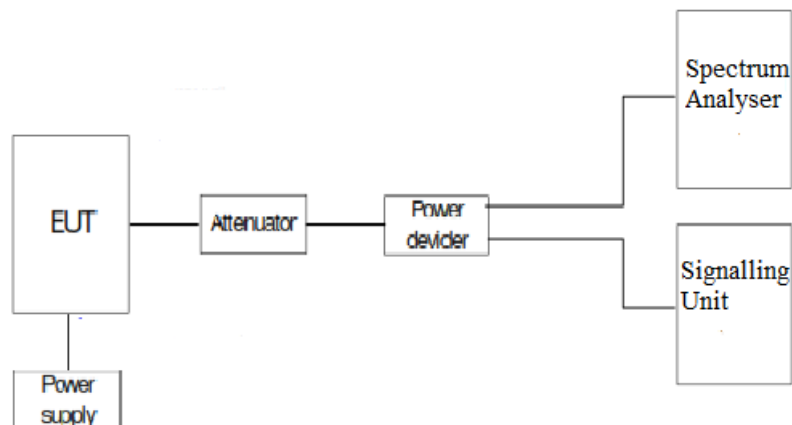

RESULTS (see plots in next pages)

NBLoT BAND 12.

(Channels in Band 12):	Tone= 3.75 kHz. Offset=0. $\pi/4$ - QPSK	Tone= 15 kHz. Offset=0. $\pi/4$ - QPSK	12 Tones= 15 kHz. Offset=0. $\pi/4$ - QPSK
Maximum measured level at lowest Block Edge at antenna port (dBm)	-31.94	-30.01	-37

(Channels in Band 12):	Tone= 3.75 kHz. Offset=47. $\pi/4$ - QPSK	Tone= 15 kHz. Offset=11. $\pi/4$ - QPSK	12 Tones= 15 kHz. Offset=0. $\pi/4$ - QPSK
Maximum measured level at highest Block Edge at antenna port (dBm)	-27.29	-20	-25.75

NBLoT. BAND 13.

(Channels in Band 13):	Tone= 3.75 kHz. Offset=0. $\pi/4$ - QPSK	Tone= 15 kHz. Offset=0. $\pi/4$ - QPSK	12 Tones= 15 kHz. Offset=0. $\pi/4$ - QPSK
Maximum measured level at lowest Block Edge at antenna port (dBm)	-36.20	-20.47	-25.70

(Channels in Band 13):	Tone= 3.75 kHz. Offset=47. $\pi/4$ - QPSK	Tone= 15 kHz. Offset=11. $\pi/4$ - QPSK	12 Tones= 15 kHz. Offset=0. $\pi/4$ - QPSK
Maximum measured level at highest Block Edge at antenna port (dBm)	-33.82	-19.87	-24.43

NBLoT. BAND 66.

(Channels in Band 66):	Tone= 3.75 kHz. Offset=0. $\pi/4$ - QPSK	Tone= 15 kHz. Offset=0. $\pi/4$ - QPSK	12 Tones= 15 kHz. Offset=0. $\pi/4$ - QPSK
Maximum measured level at lowest Block Edge at antenna port (dBm)	-30.15	-35.34	-28.75

(Channels in Band 66):	Tone= 3.75 kHz. Offset=47. $\pi/4$ - QPSK	Tone= 15 kHz. Offset=11. $\pi/4$ - QPSK	12 Tones= 15 kHz. Offset=0. $\pi/4$ - QPSK
Maximum measured level at highest Block Edge at antenna port (dBm)	-27.48	-32.16	-30

NBLoT. BAND 85.

(Channels in Band 85):	Tone= 3.75 kHz. Offset=0. $\pi/4$ - QPSK	Tone= 15 kHz. Offset=0. $\pi/4$ - QPSK	12 Tones= 15 kHz. Offset=0. $\pi/4$ - QPSK
Maximum measured level at lowest Block Edge at antenna port (dBm)	-21.75	-29.28	-22.22

(Channels in Band 85):	Tone= 3.75 kHz. Offset=47. $\pi/4$ - QPSK	Tone= 15 kHz. Offset=11. $\pi/4$ - QPSK	12 Tones= 15 kHz. Offset=0. $\pi/4$ - QPSK
Maximum measured level at highest Block Edge at antenna port (dBm)	-20.89	-31.72	-30.98

Measurement uncertainty = ± 1.20 dB.

Verdict: PASS

NB-IoT. BAND 12.

1 tone $\pi/2$ – BPSK. BW=3.75 kHz Offset = 0

CHANNEL LOWEST

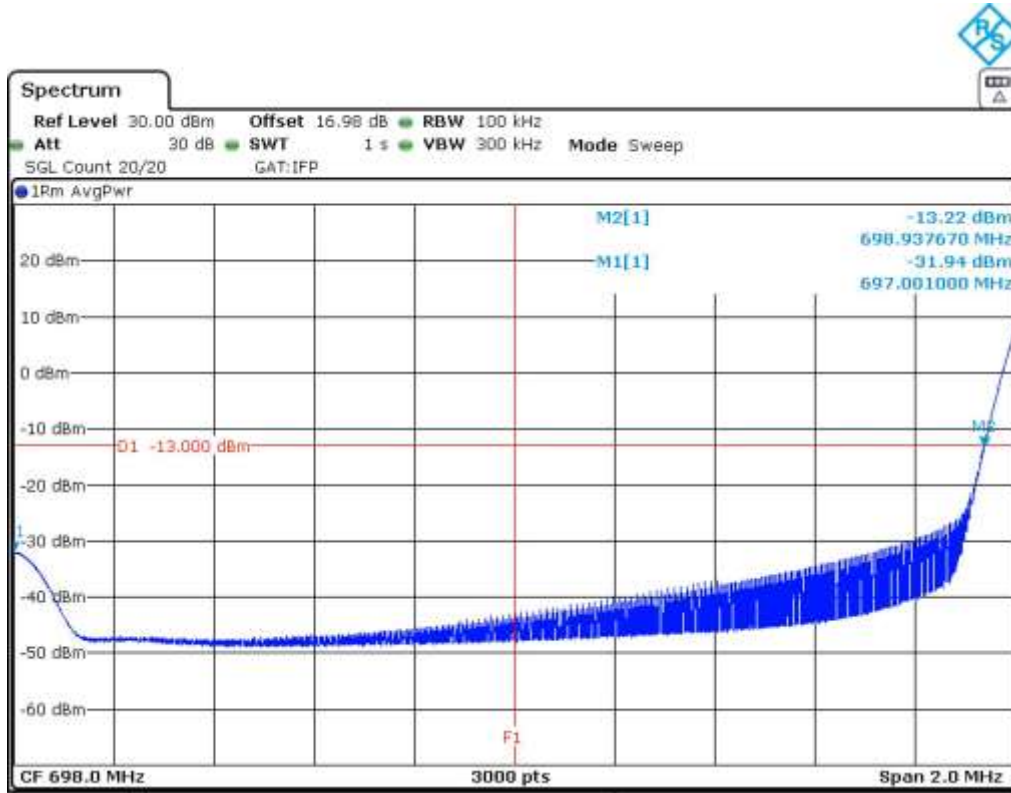

1 tone $\pi/2$ – BPSK. BW=3.75 kHz Offset = 47

CHANNEL HIGHEST

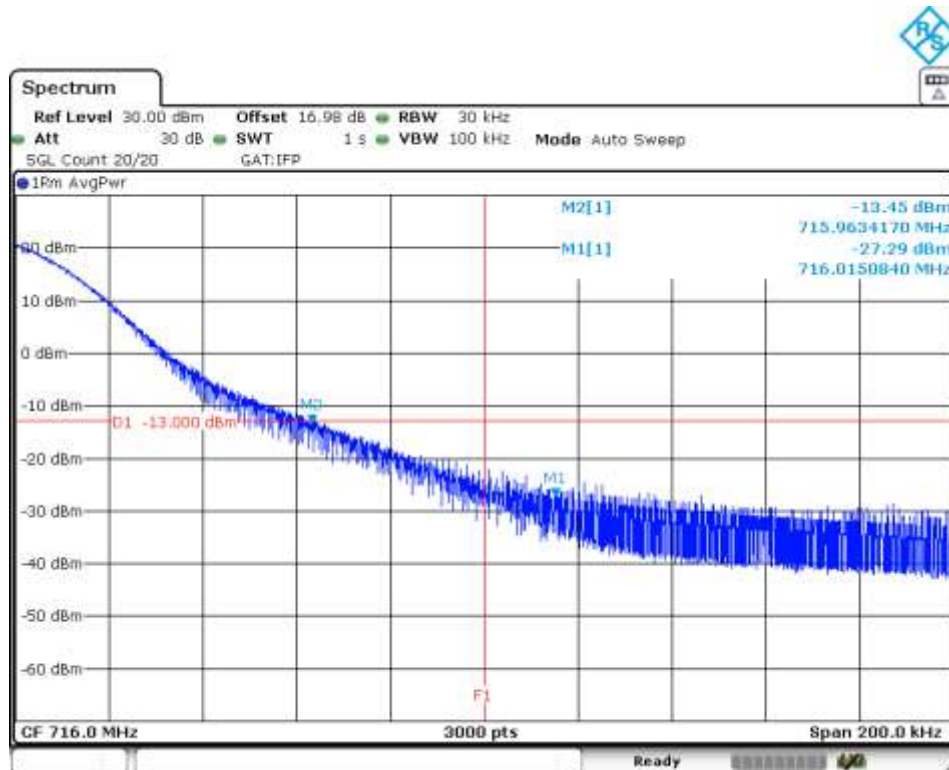

NOTE: Zoom (100KHz) with RBW=30KHz.

NB IoT. BAND 12.

1 tone $\pi/4$ – QPSK. BW=15 kHz Offset = 0

CHANNEL LOWEST

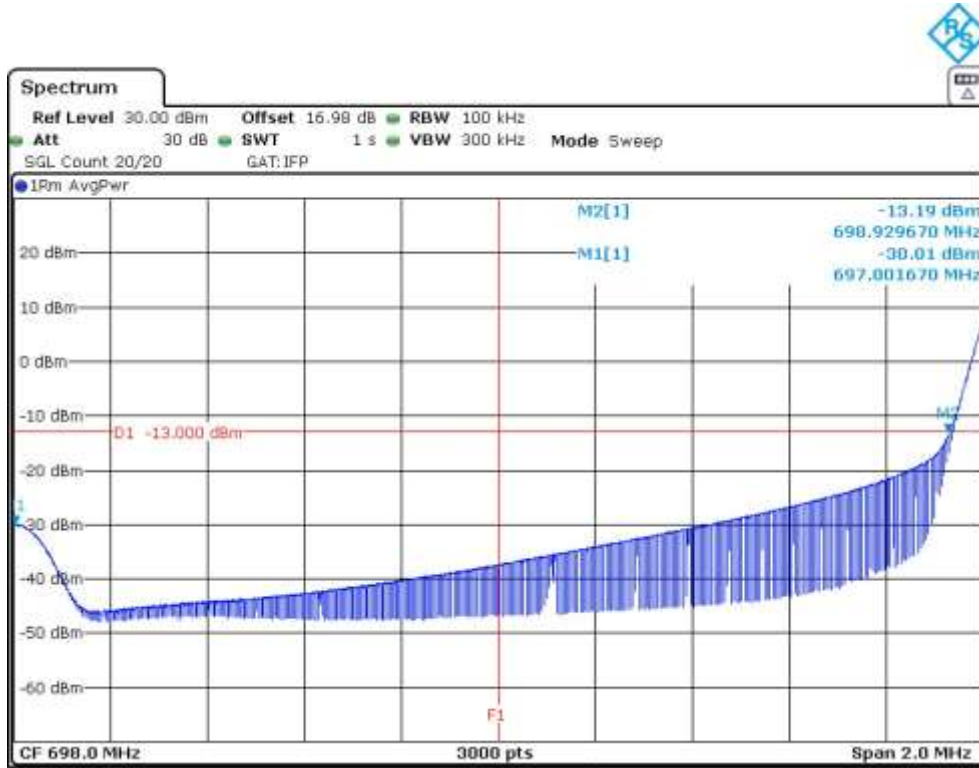

1 tone $\pi/4$ – QPSK. BW=15 kHz Offset = 11

CHANNEL HIGHEST

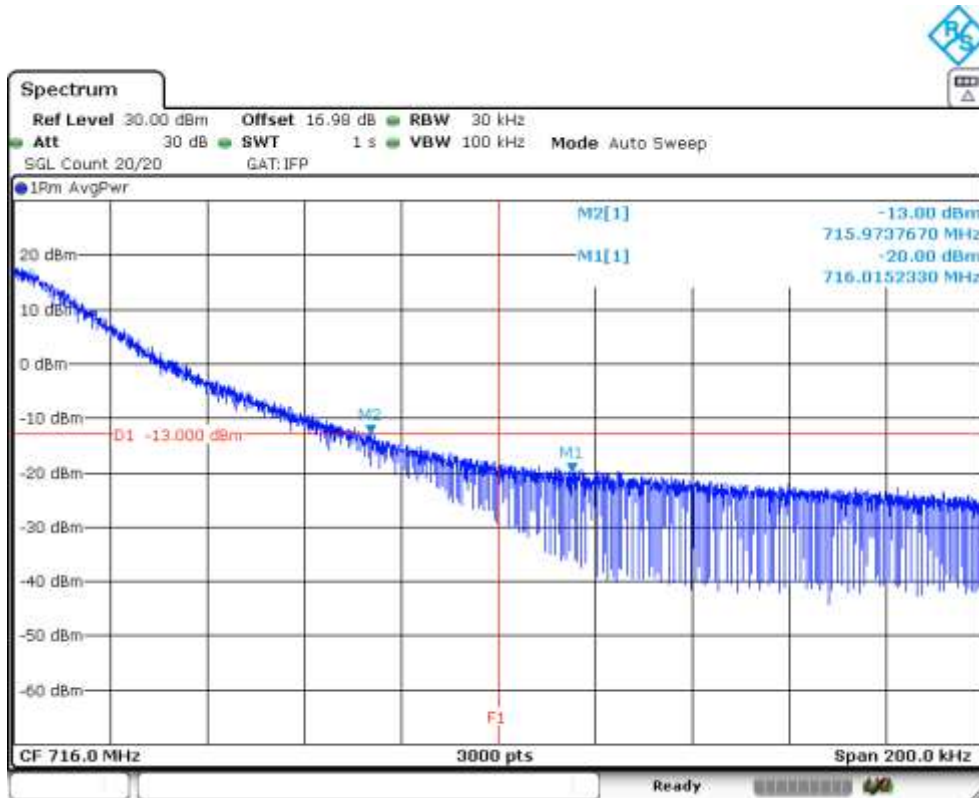

NB-IoT. BAND 12.

12 tone $\pi/4$ – QPSK. BW=15 kHz Offset = 0

CHANNEL LOWEST

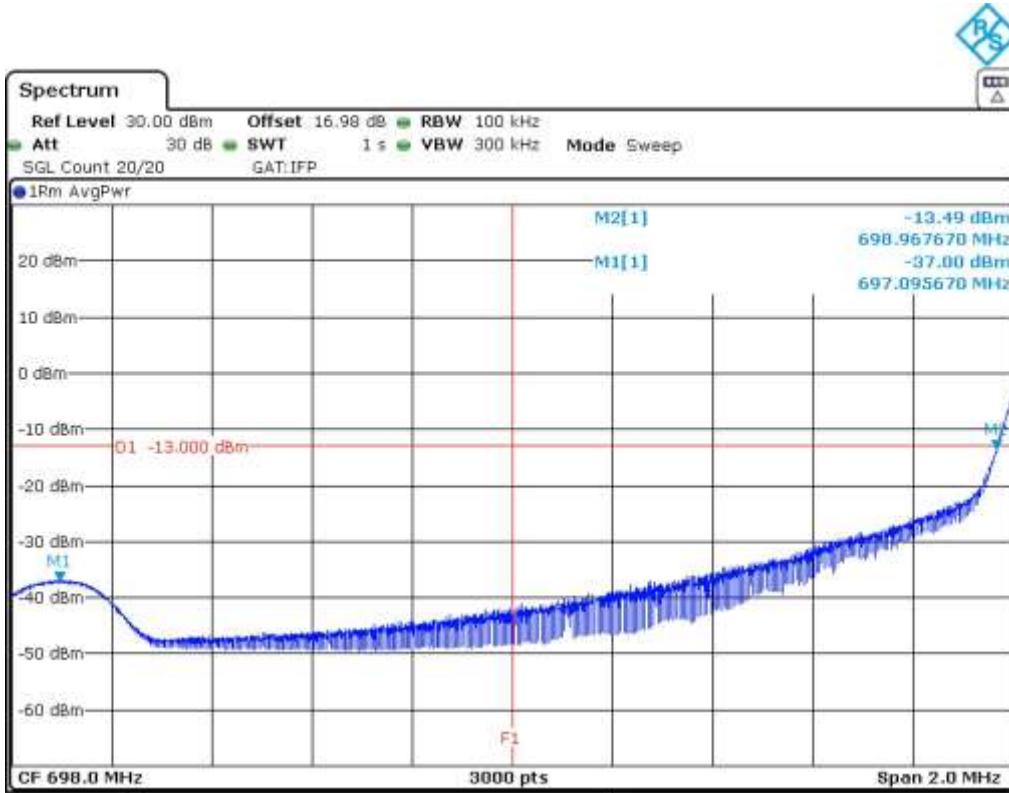

1 tone $\pi/4$ – QPSK. BW=15 kHz Offset = 0

CHANNEL HIGHEST

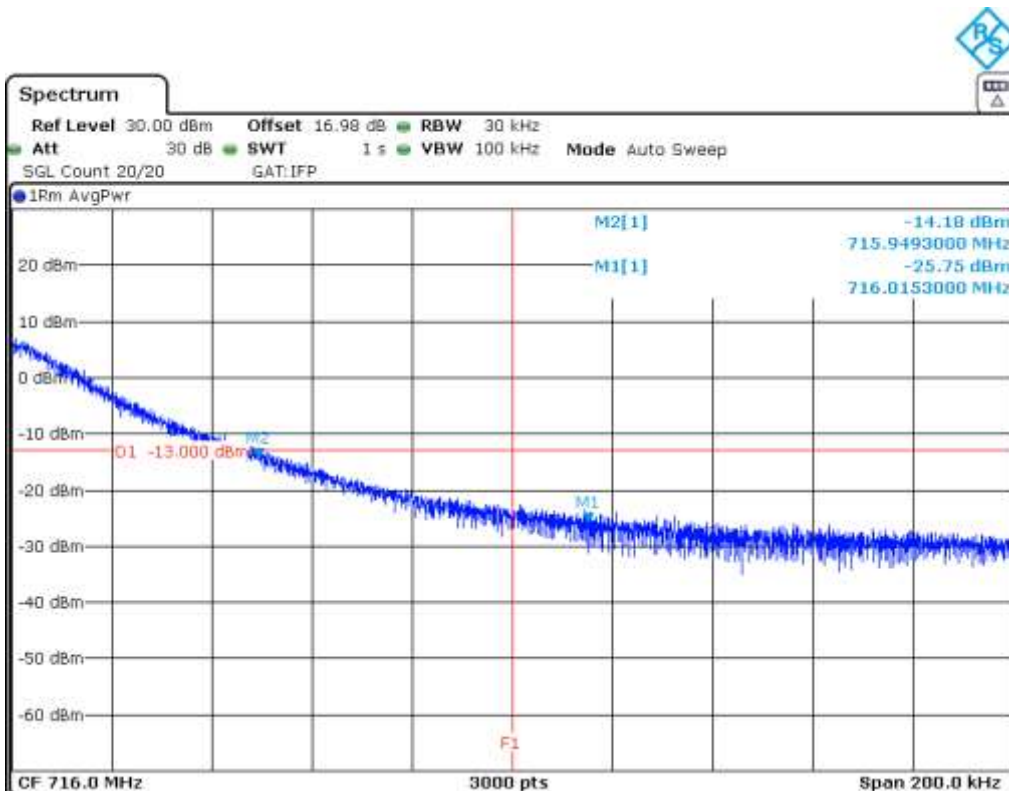

NBIoT. BAND 13.

1 tone $\pi/2$ – BPSK. BW=3.75 kHz Offset = 0

CHANNEL LOWEST

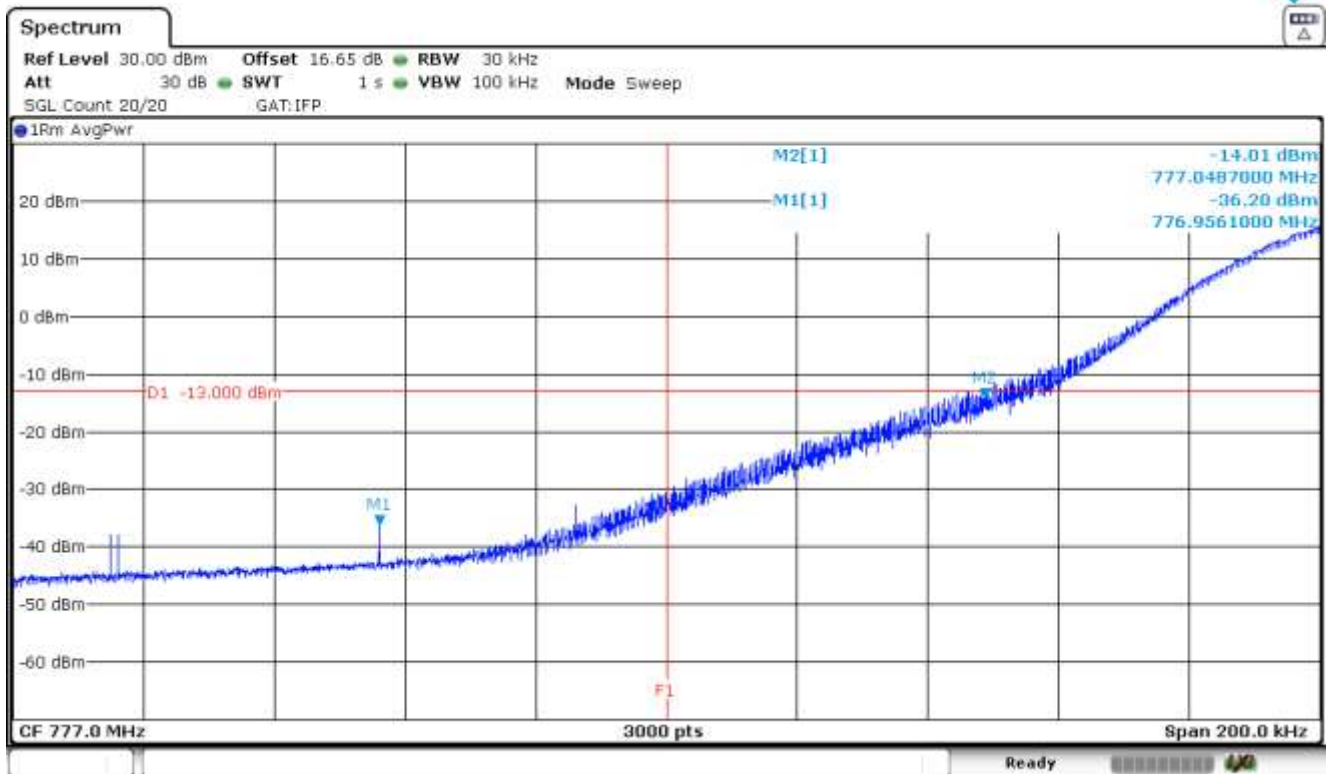
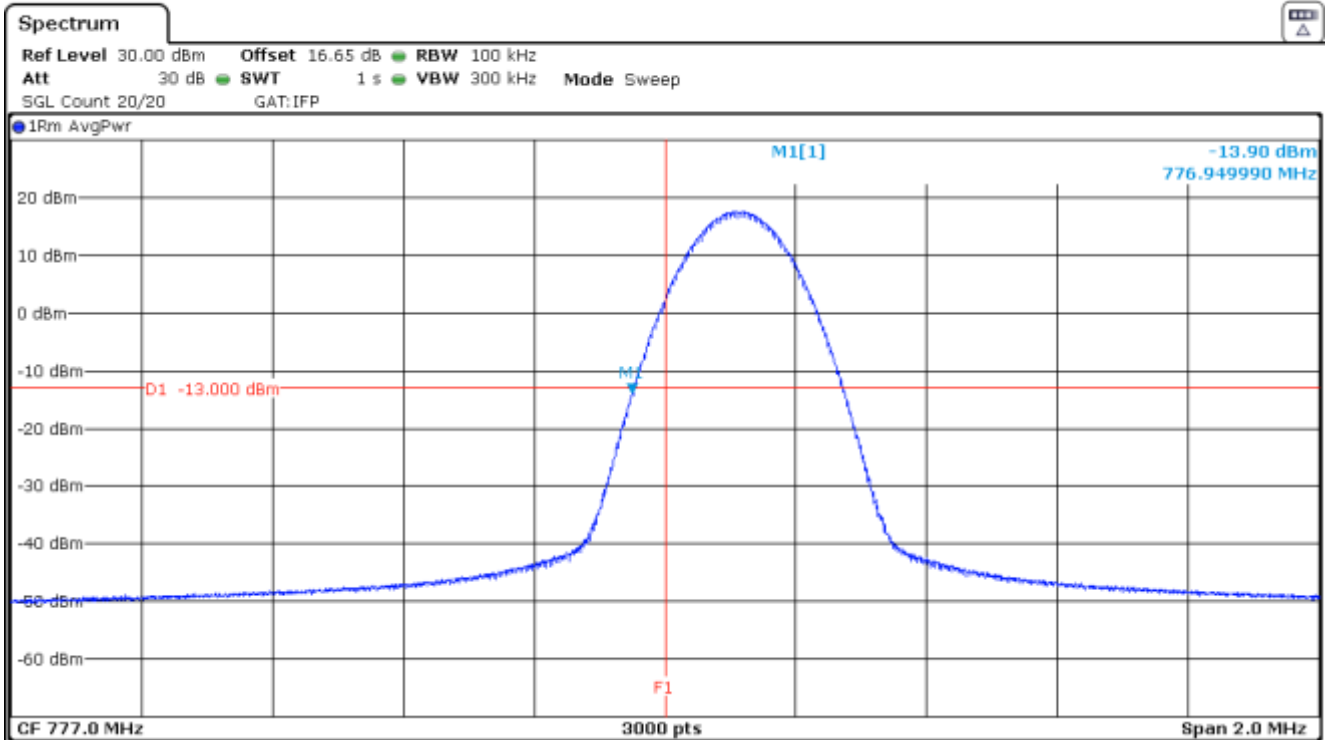

NOTE: Zoom (100KHz) with RBW=30KHz

1 tone $\pi/2$ – BPSK. BW=3.75 kHz Offset = 47
 CHANNEL HIGHEST

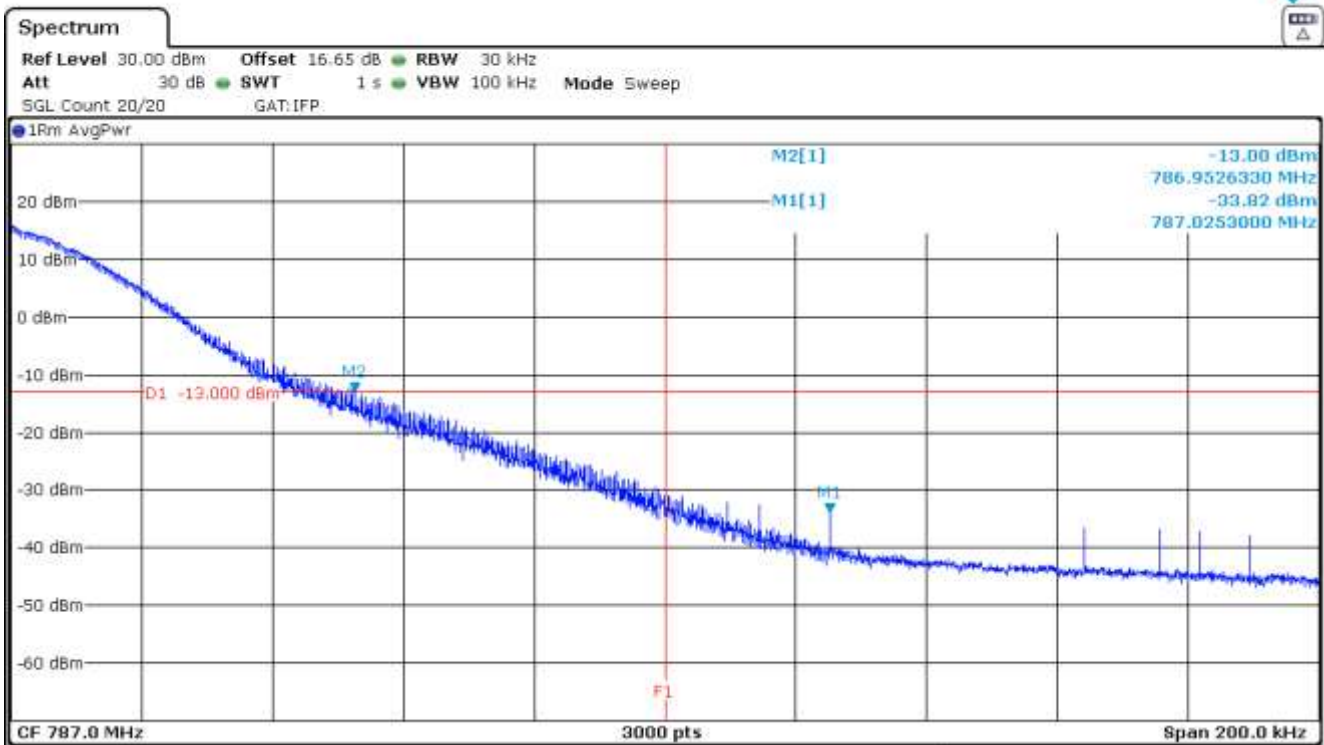
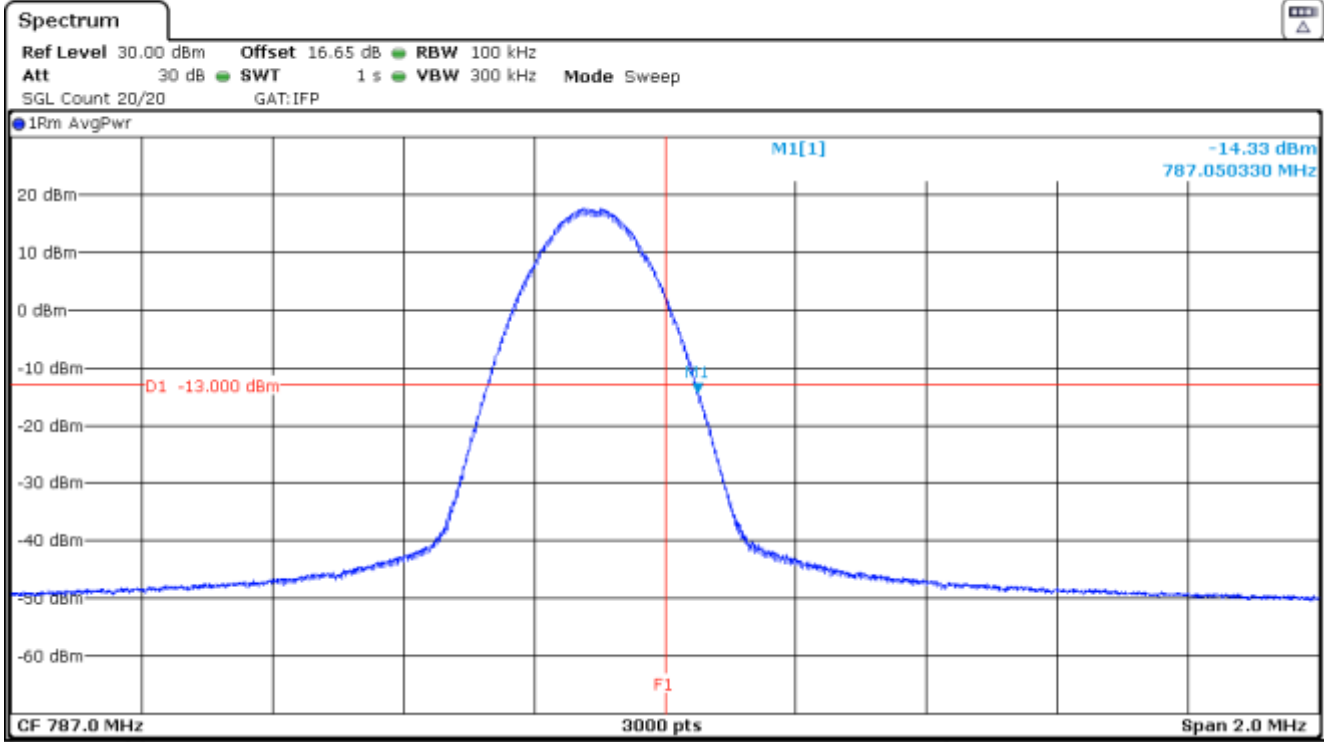

NOTE: Zoom (100KHz) with RBW=30KHz.

NBLoT. BAND 13.

1 tone $\pi/4$ – QPSK. BW=15 kHz Offset = 0

CHANNEL LOWEST

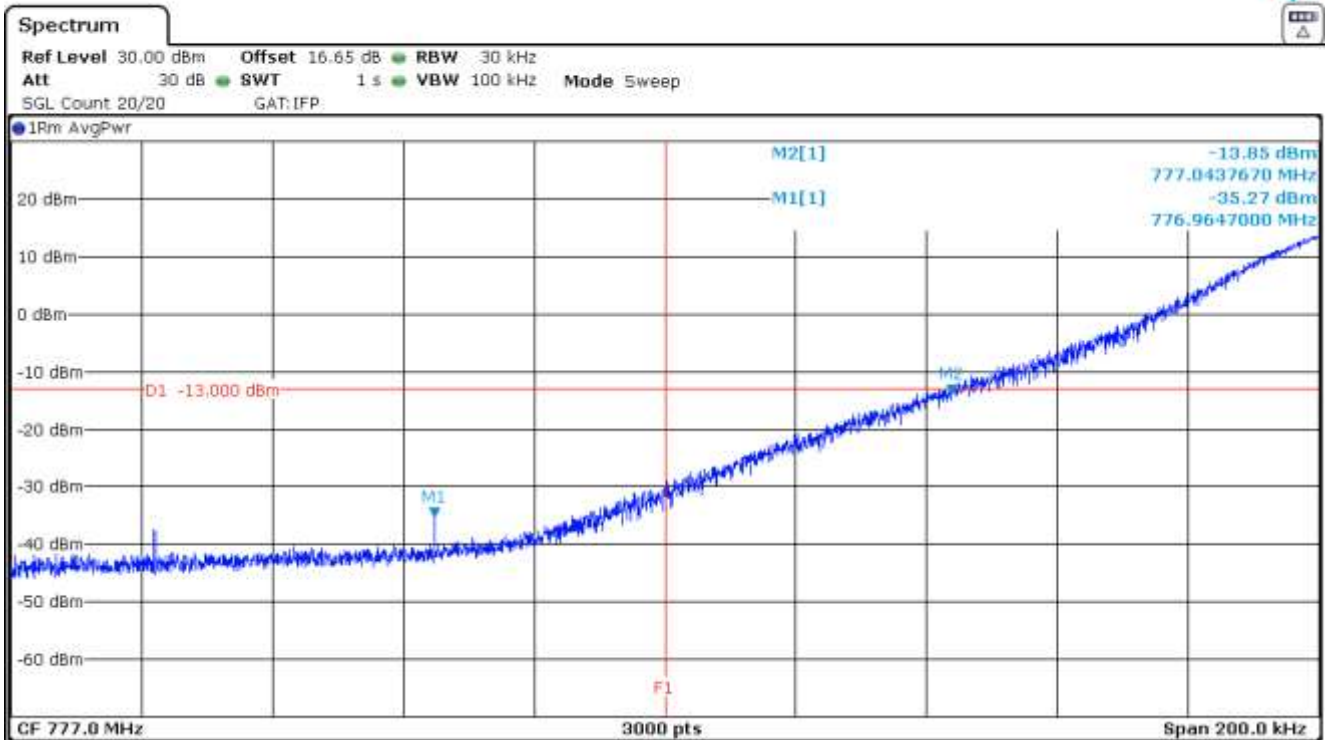
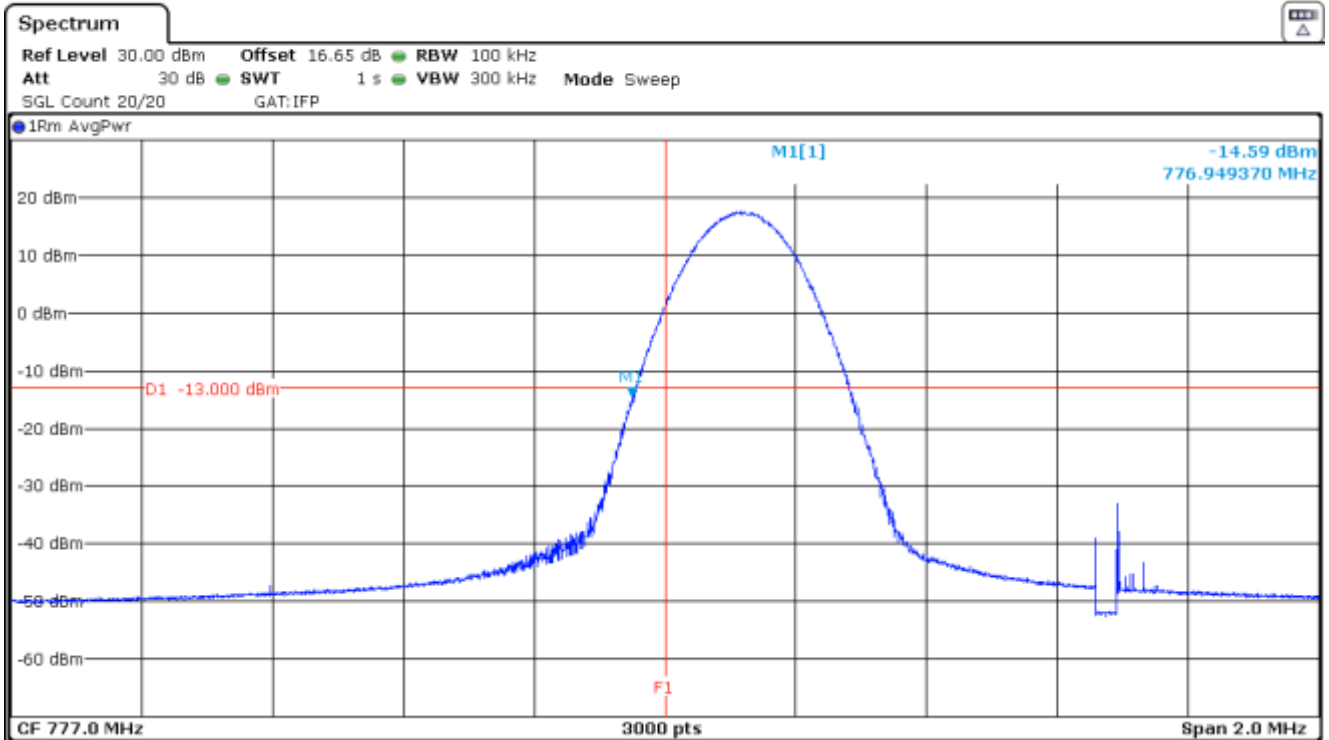

NOTE: Zoom (100KHz) with RBW=30KHz.

1 tone $\pi/4$ – QPSK. BW=15 kHz Offset = 11
 CHANNEL HIGHEST

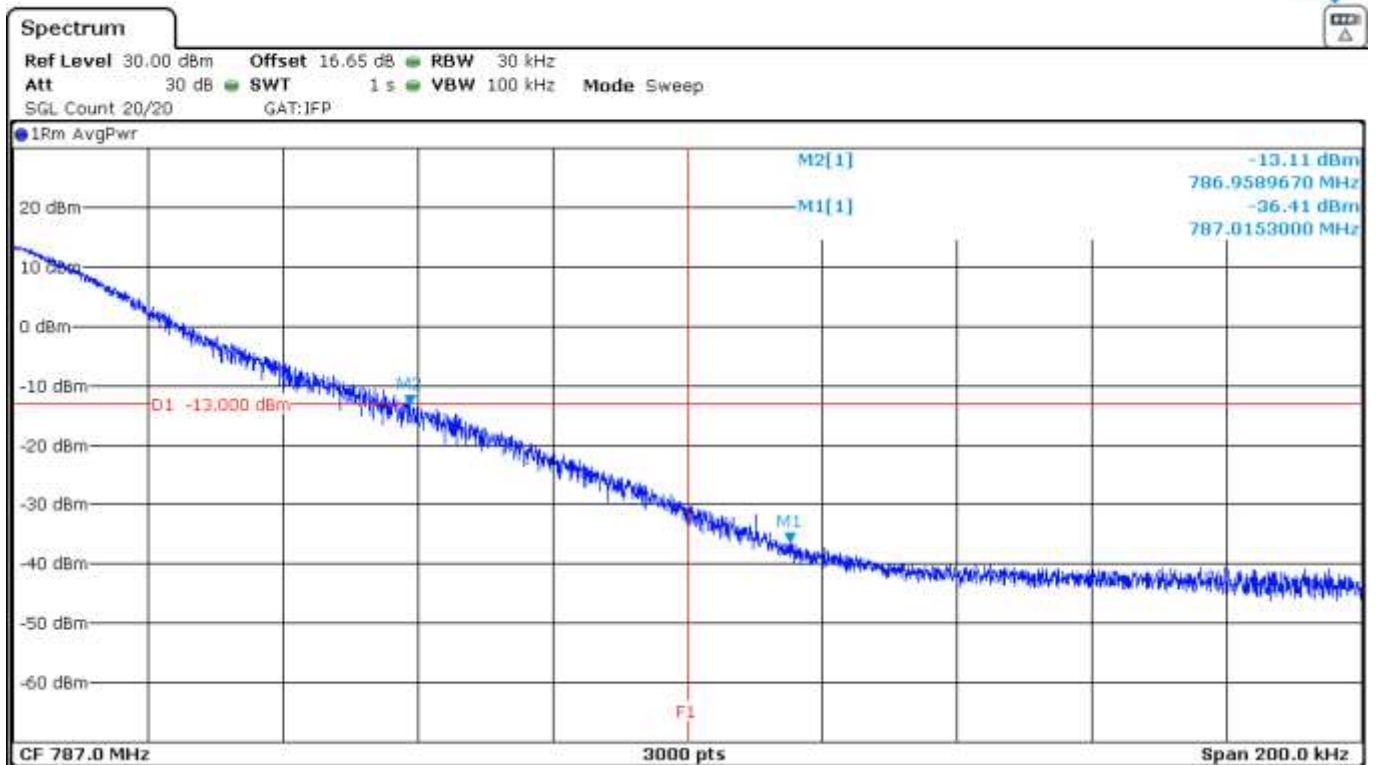
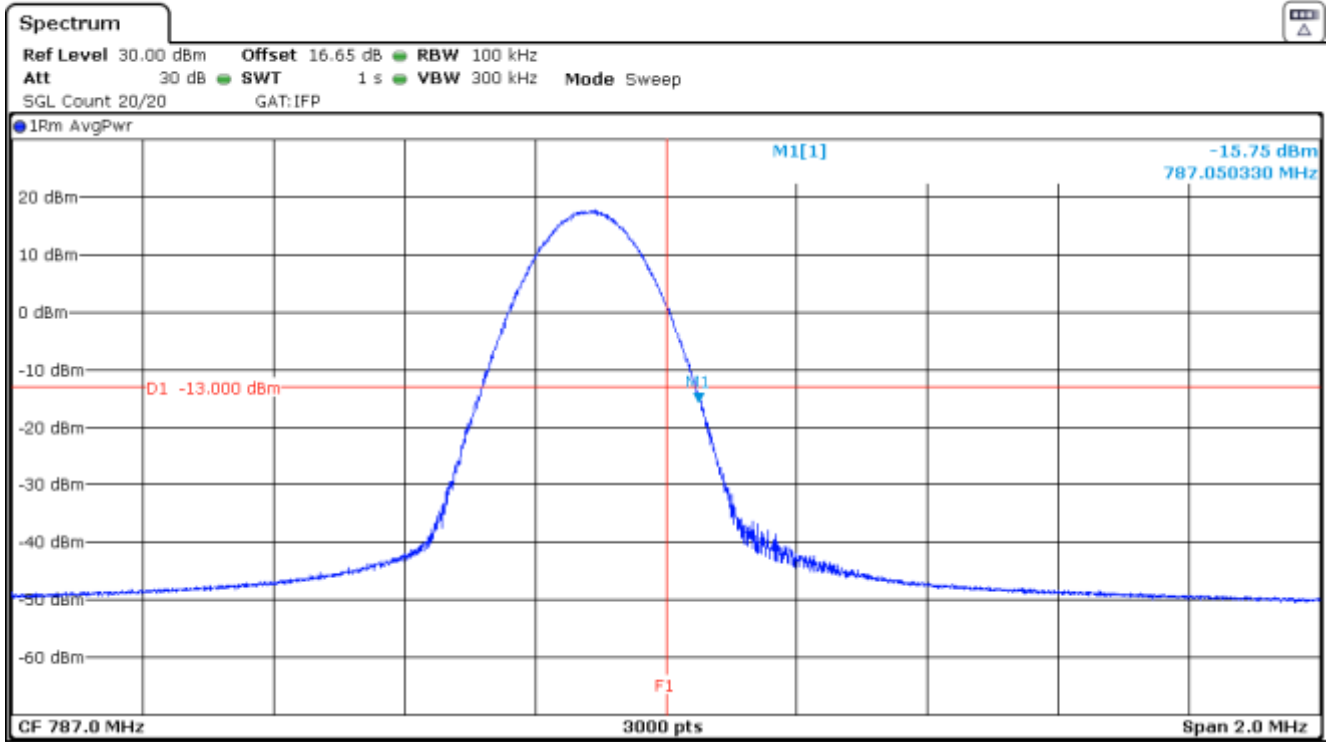

NOTE: Zoom (100kHz) with RBW=30kHz.

NB-IoT. BAND 13.

12 tone $\pi/4$ – QPSK. BW=15 kHz Offset = 0

CHANNEL LOWEST

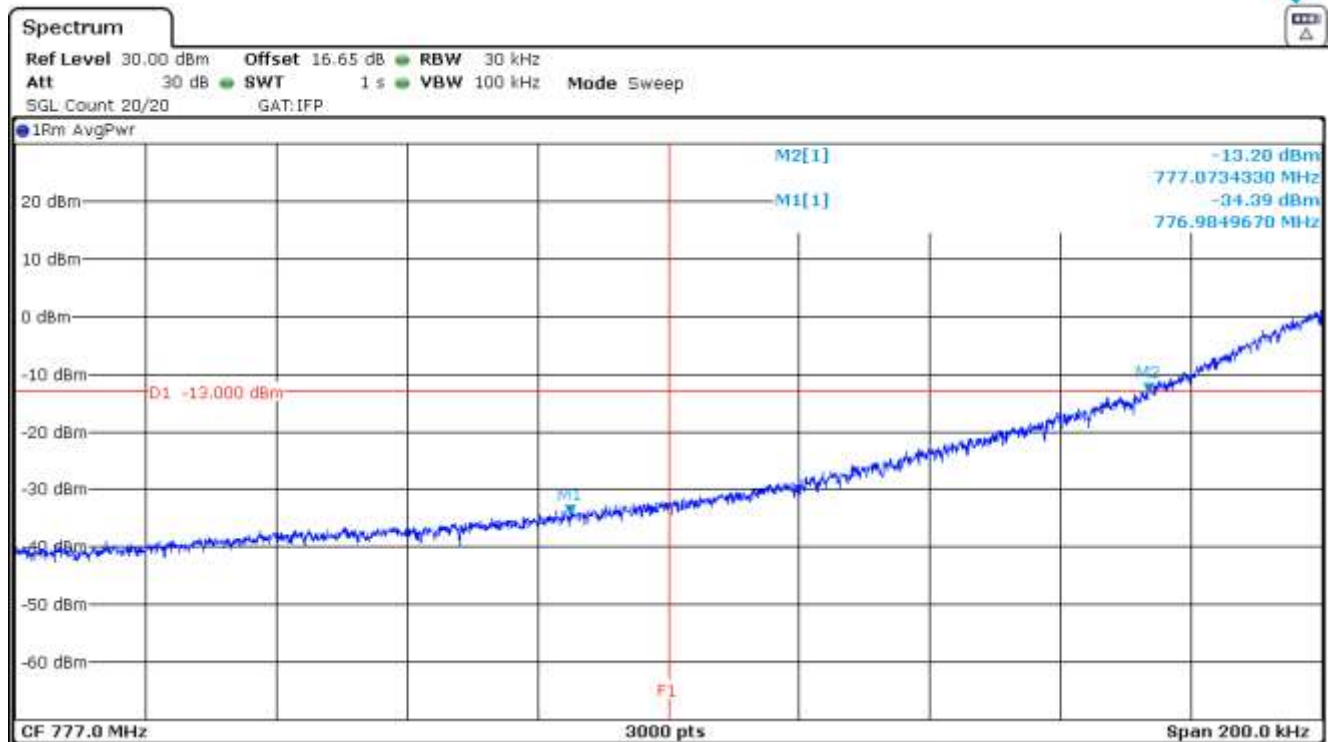
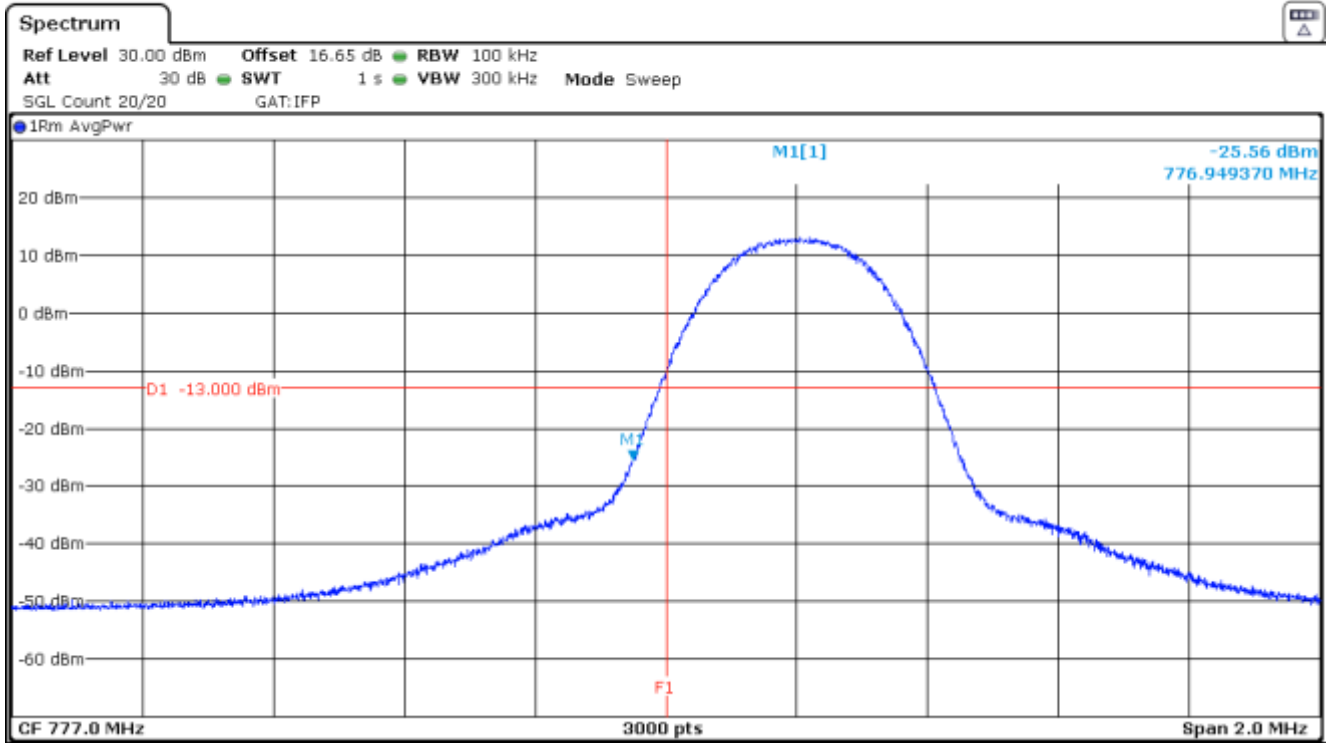

NB IoT. BAND 13.

12 tone $\pi/4$ – QPSK. BW=15 kHz Offset = 0

CHANNEL HIGHEST

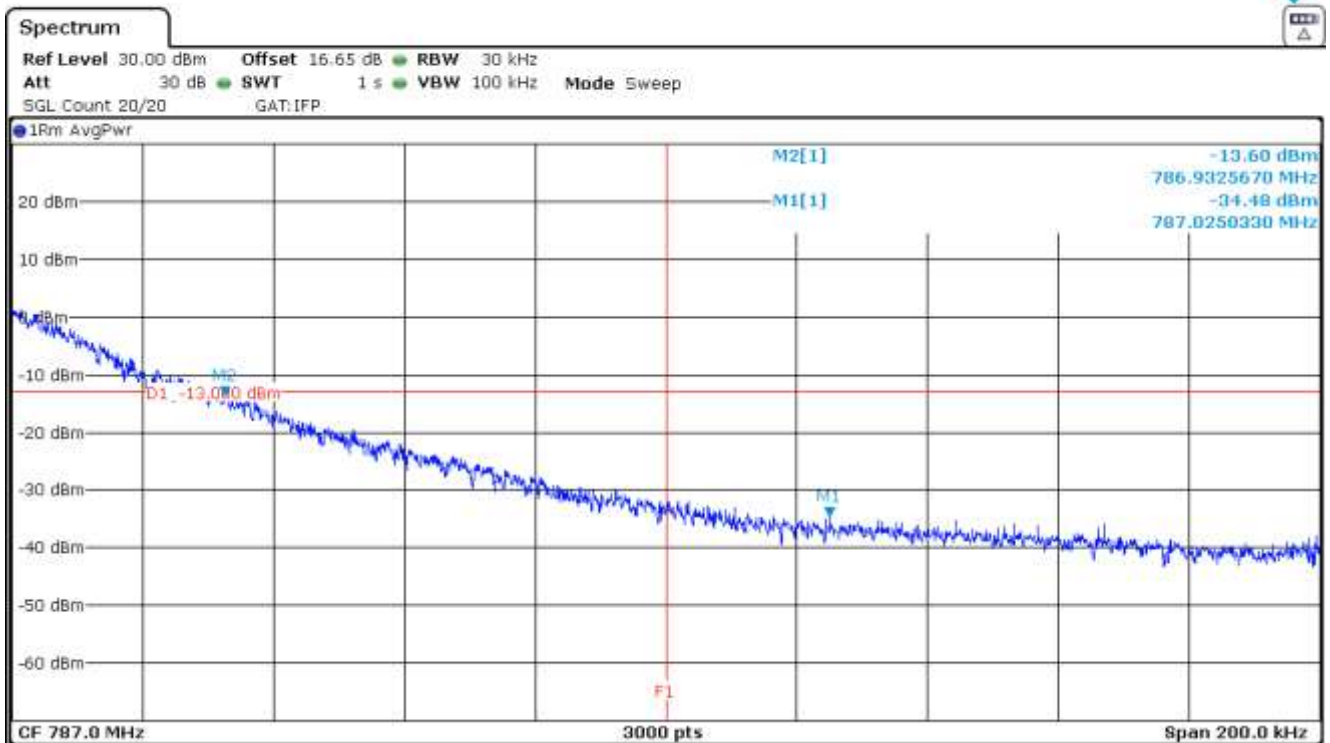
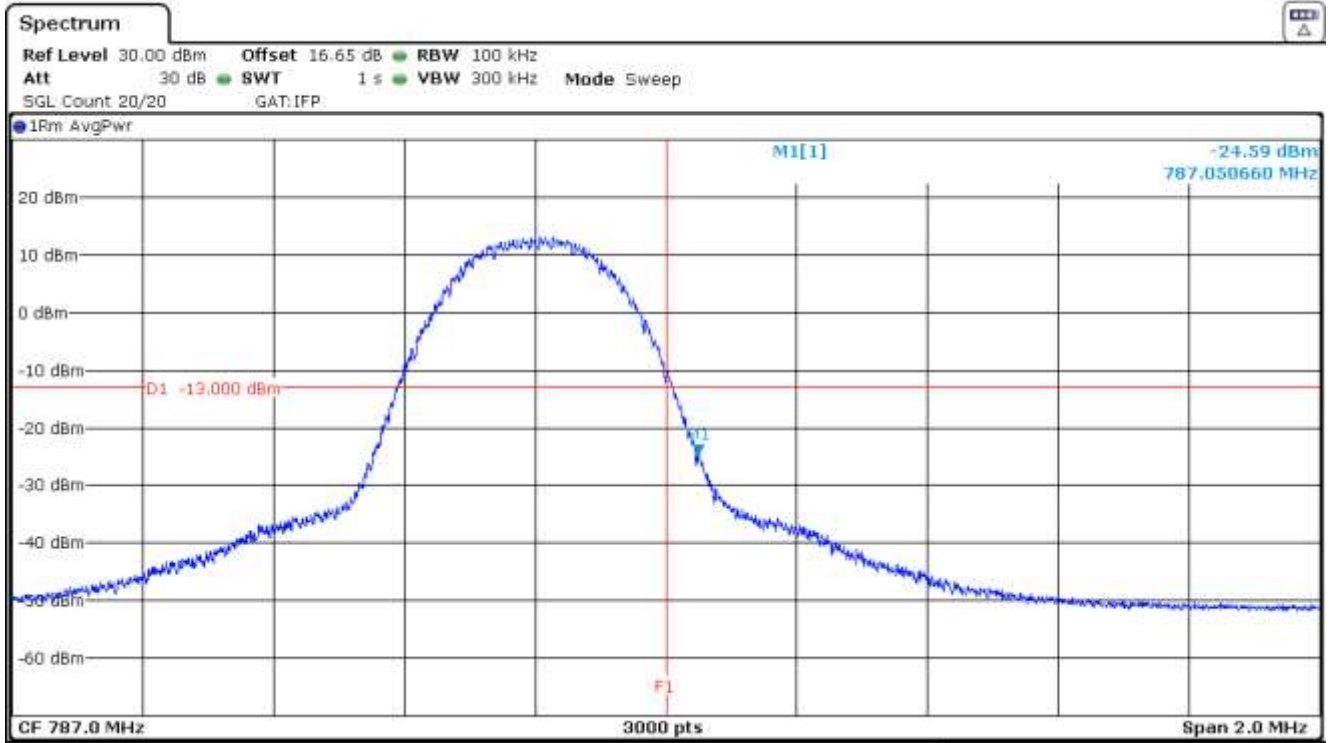

NOTE: Zoom (100KHz) with RBW=30KHz.

NB-IoT. BAND 66.

1 tone $\pi/2$ – BPSK. BW=3.75 kHz Offset = 0

CHANNEL LOWEST

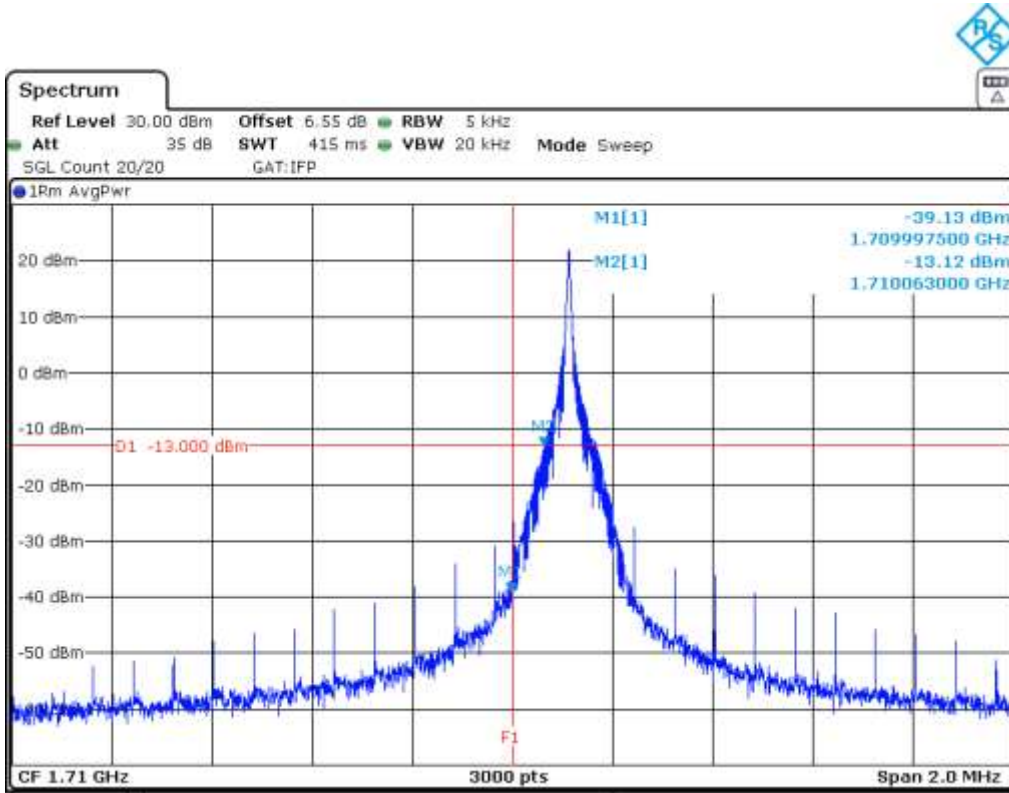

1 tone $\pi/2$ – BPSK. BW=3.75 kHz Offset = 47

CHANNEL HIGHEST

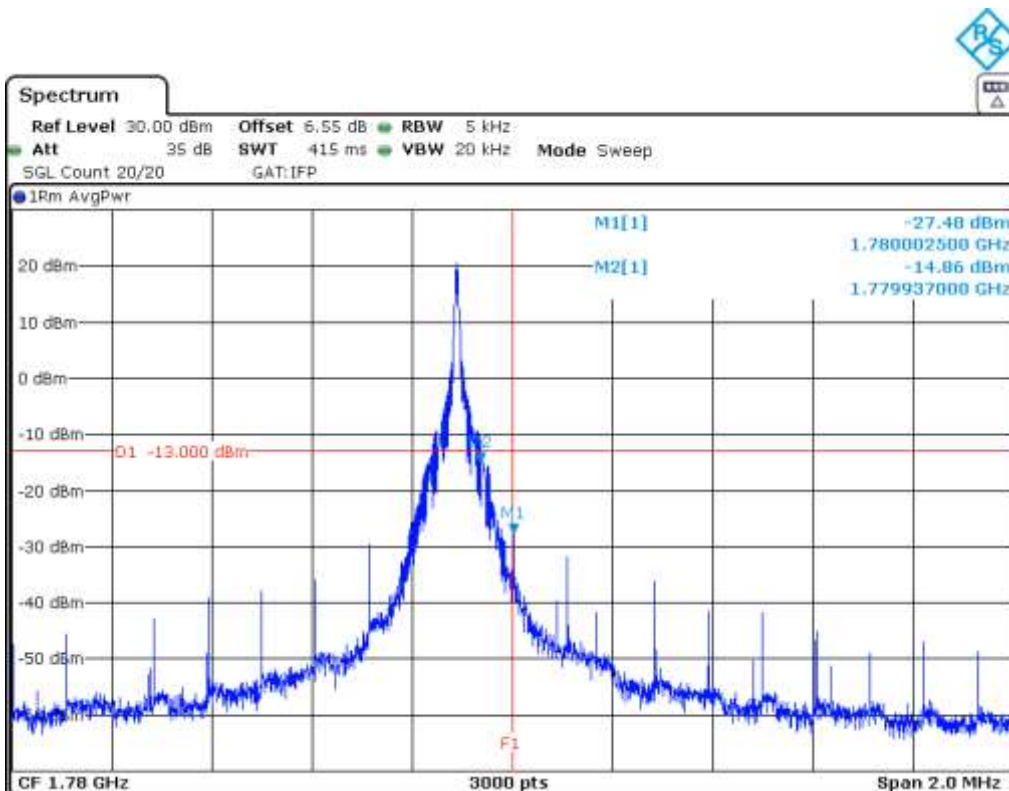

NB IoT. BAND 66.

1 tone $\pi/2$ – BPSK. BW=15 kHz Offset = 0

CHANNEL LOWEST

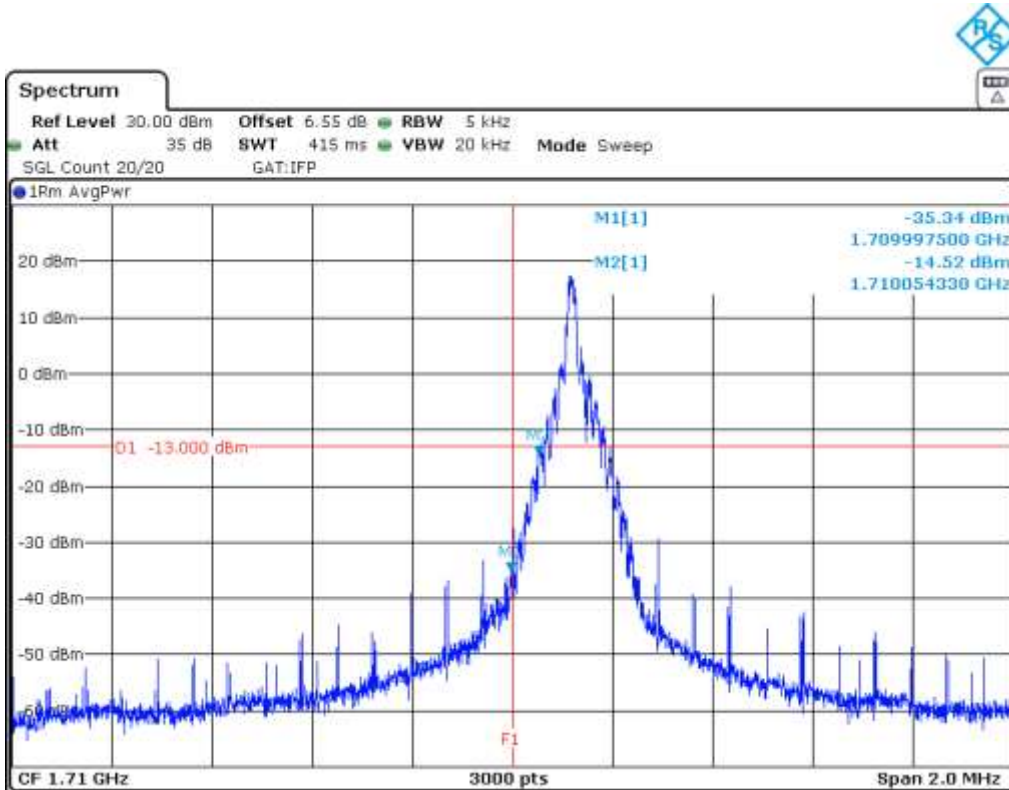

1 tone $\pi/2$ – BPSK. BW=15 kHz Offset = 11

CHANNEL HIGHEST

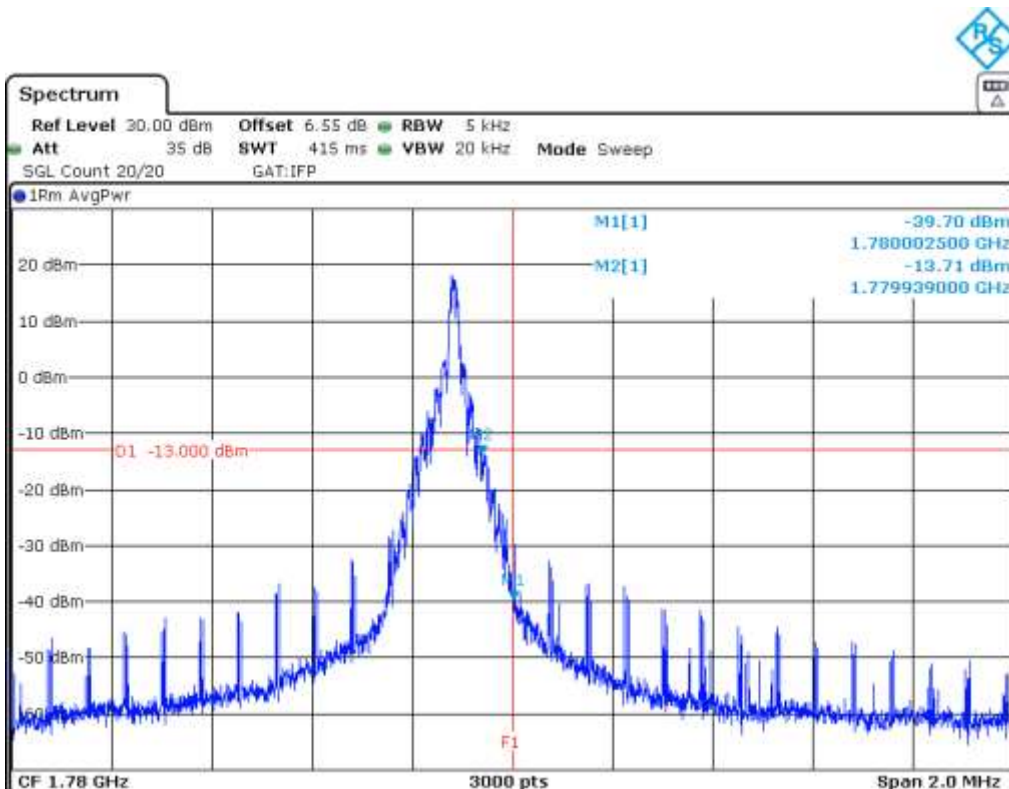

NB-IoT. BAND 66.

15 tone $\pi/4$ – QPSK. BW=15 kHz Offset = 0

CHANNEL LOWEST

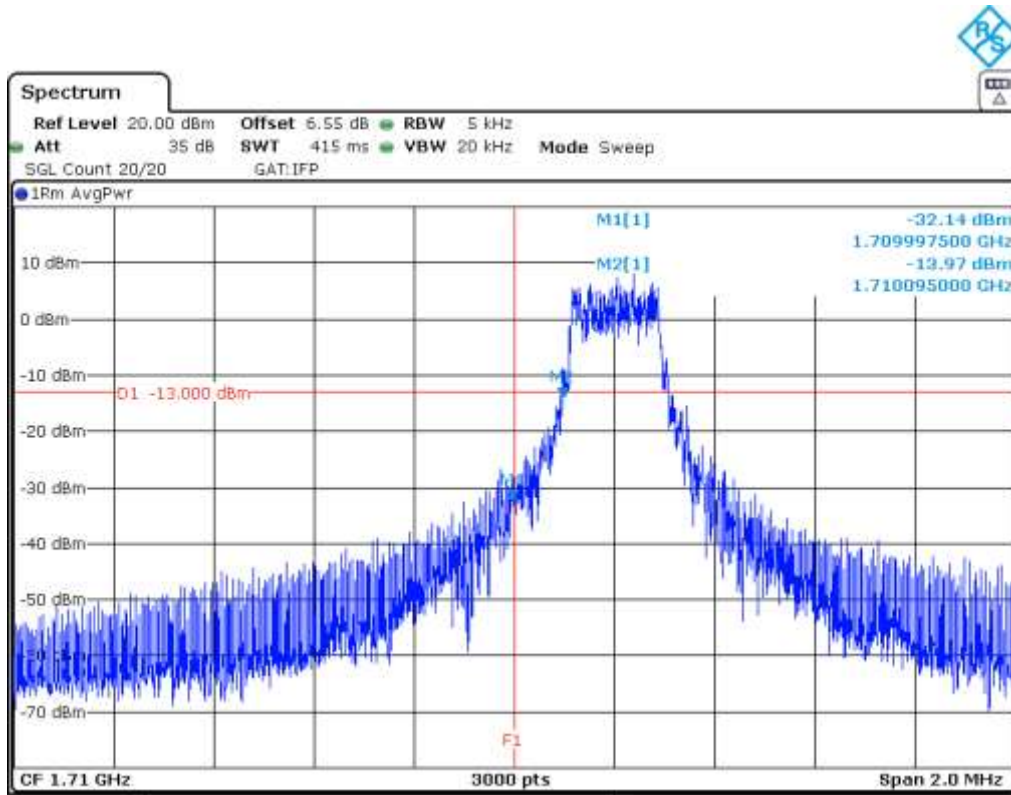

15 tone $\pi/4$ – QPSK. BW=15 kHz Offset = 0

CHANNEL HIGHEST

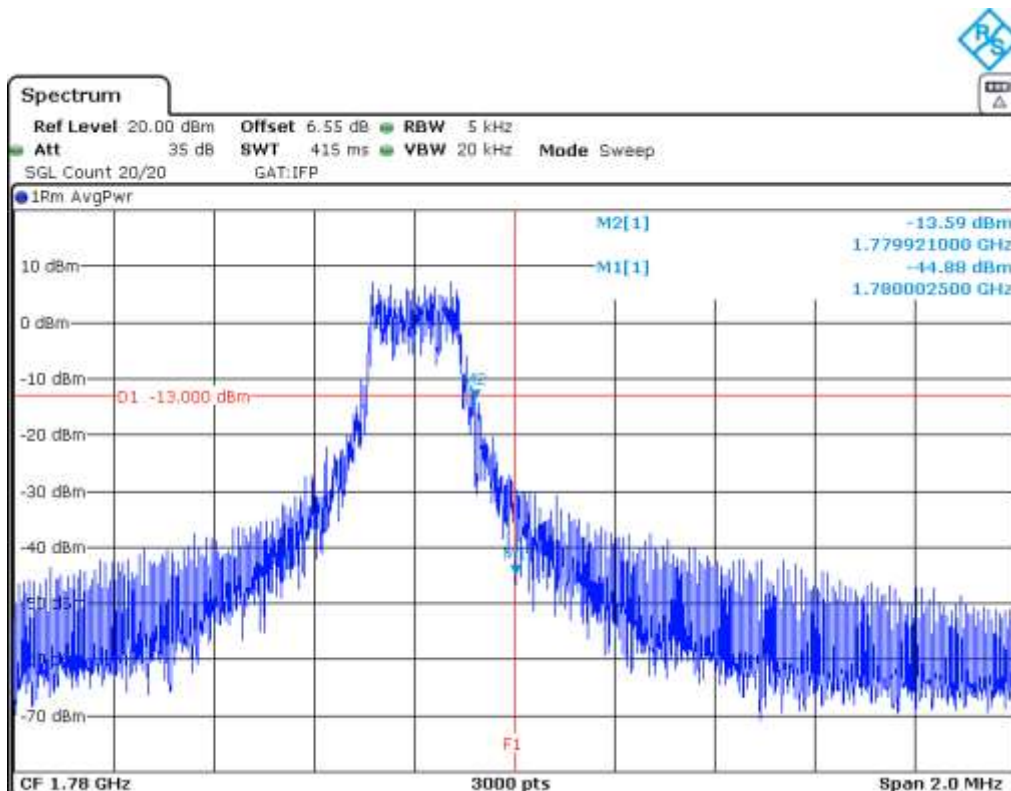

NB-IoT. BAND 85.

1 tone $\pi/4$ – QPSK. BW=3.75 kHz Offset = 0

CHANNEL LOWEST

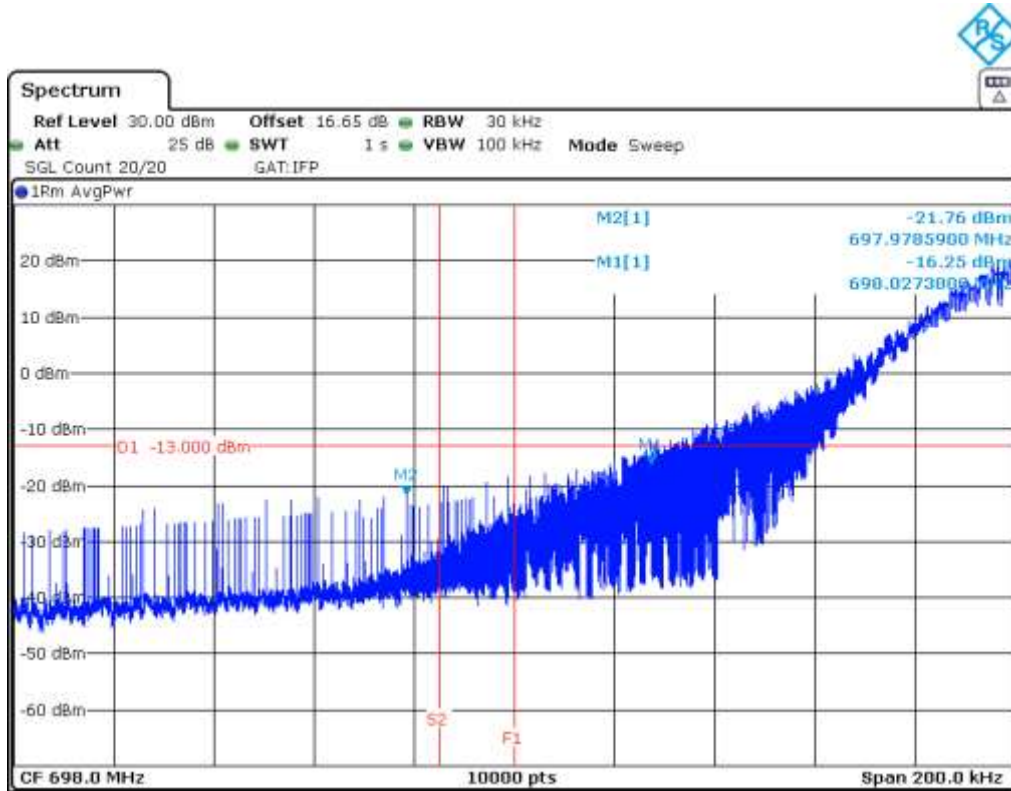

1 tone $\pi/4$ – QPSK. BW=3.75 kHz Offset = 47

CHANNEL HIGHEST

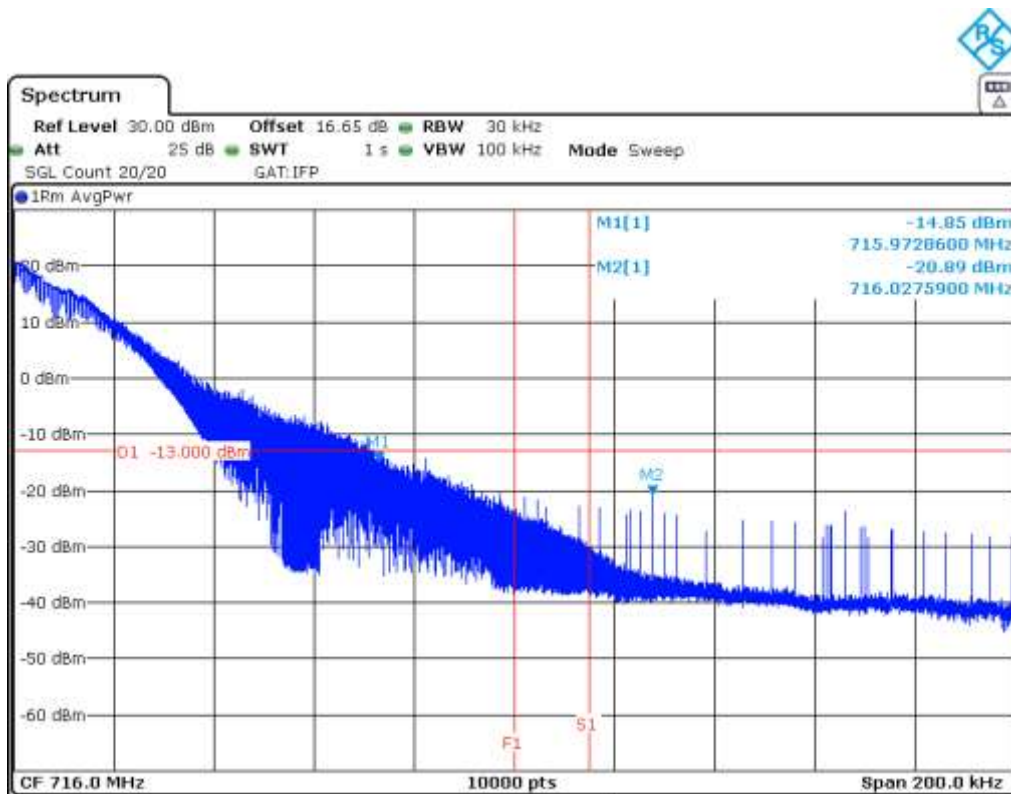

NB-IoT. BAND 85.

1 tone $\pi/4$ – QPSK. BW=15 kHz Offset = 0

CHANNEL LOWEST

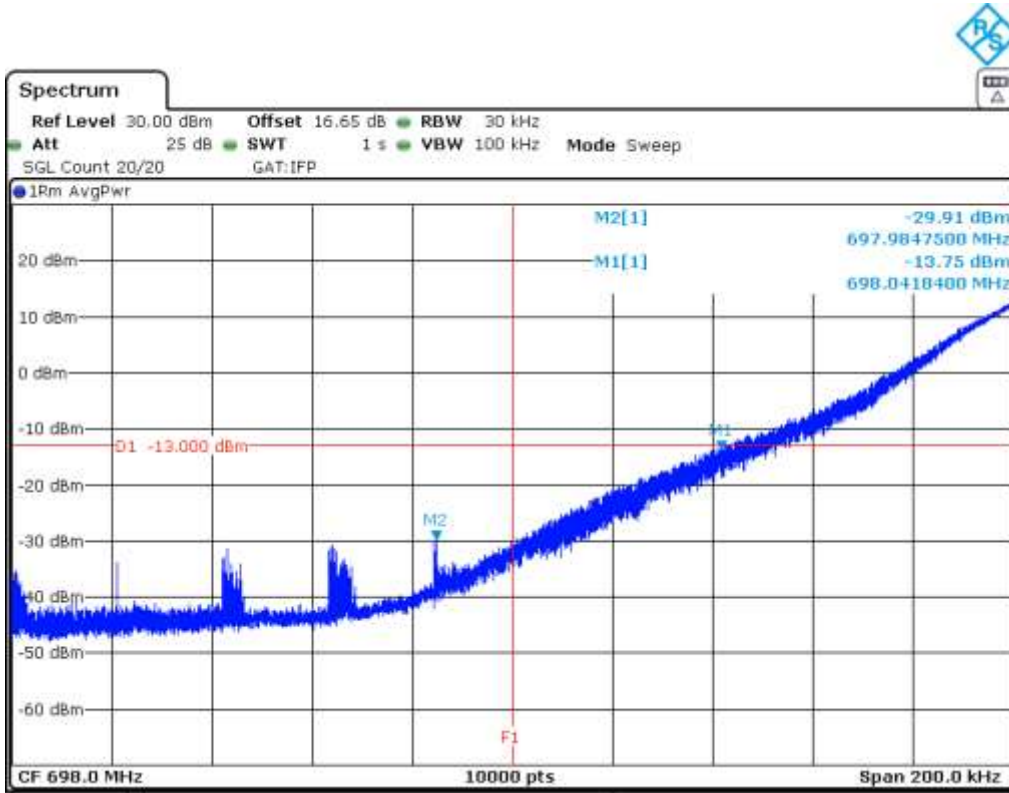

1 tone $\pi/4$ – QPSK. BW=15 kHz Offset = 11

CHANNEL HIGHEST

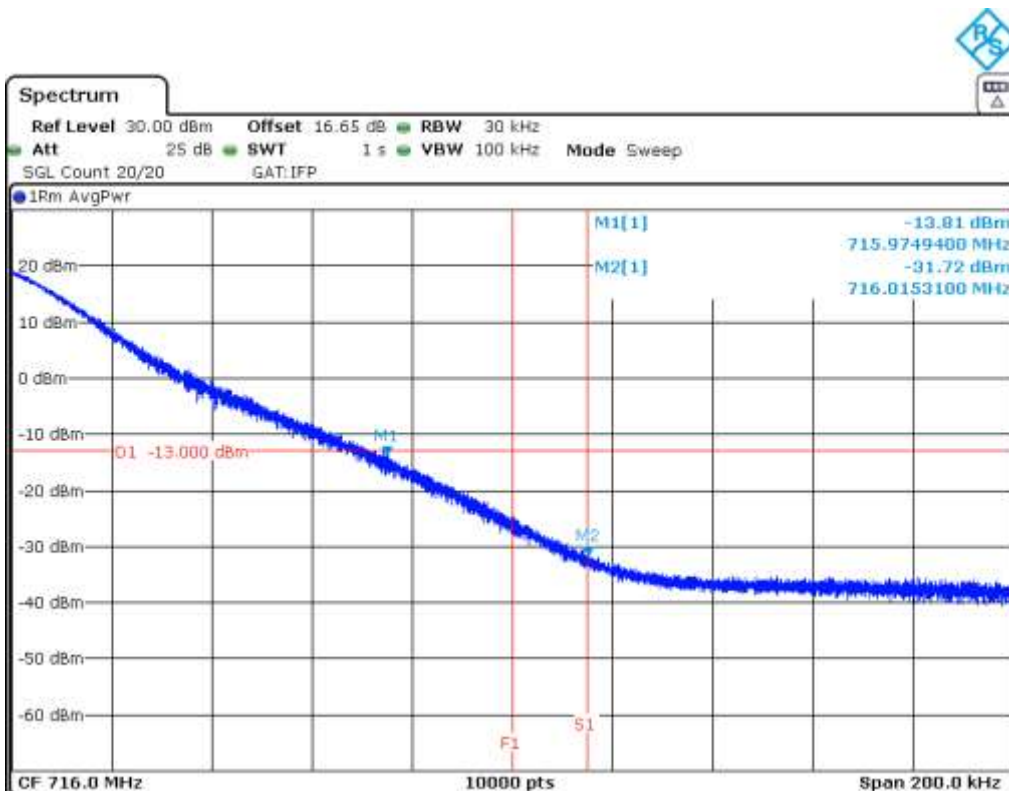

NB-IoT. BAND 85.

12 tone $\pi/4$ – QPSK. BW=15 kHz Offset = 0

CHANNEL LOWEST

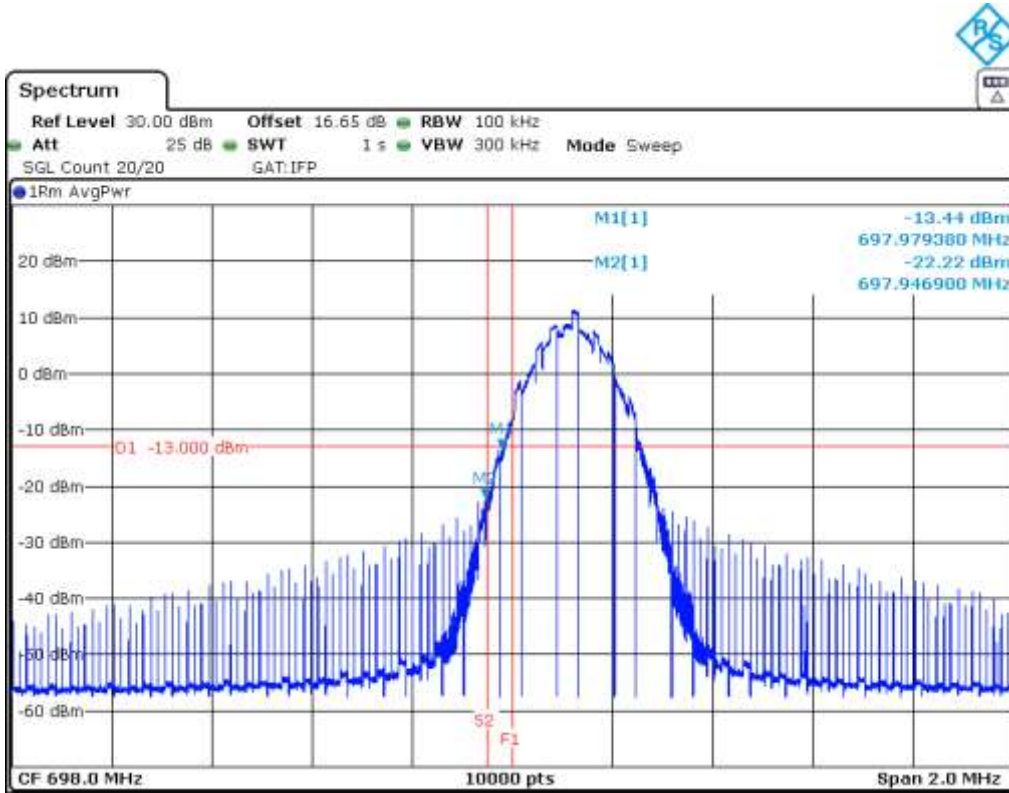

12 tone $\pi/4$ – QPSK. BW=15 kHz Offset = 0

CHANNEL HIGHEST

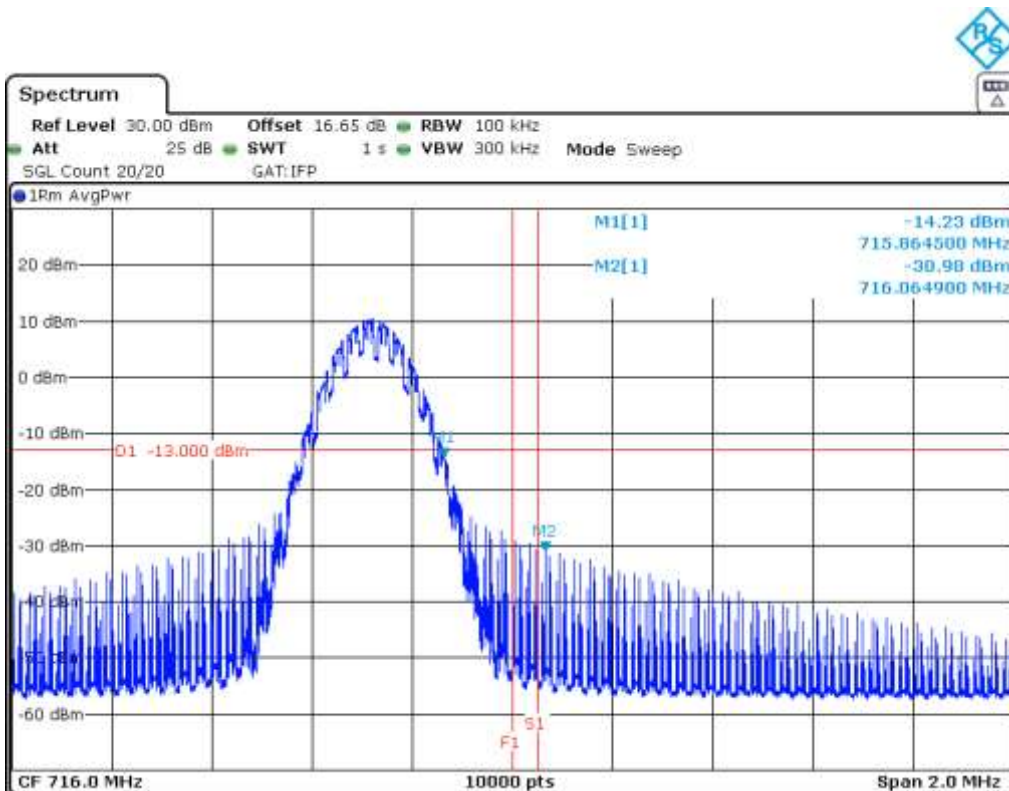

Radiated emissions

SPECIFICATION

FCC §27.53 (g).

For operations in the 600 MHz band and the 698-746 MHz band. the power of any emission outside a licensee's frequency band(s) of operation shall be attenuated below the transmitter power (P) within the licensed band(s) of operation. measured in watts. by at least $43 + 10 \log (P)$ dB. Compliance with this provision is based on the use of measurement instrumentation employing a resolution bandwidth of 100 kilohertz or greater. However. in the 100 kilohertz bands immediately outside and adjacent to a licensee's frequency block. a resolution bandwidth of at least 30 kHz may be employed

FCC §27.53 (c) & (f).

On any frequency outside the 776-788 MHz band. the power of any emission shall be attenuated outside the band below the transmitter power (P) by at least $43 + 10 \log (P)$ dB.

On all frequencies between 763-775 MHz and 793-805 MHz. by a factor not less than $65 + 10 \log (P)$ dB in a 6.25 kHz band segment. for mobile and portable stations.

For operations in the 746-758 MHz. 775-788 MHz. and 805-806 MHz bands. emissions in the band 1559-1610 MHz shall be limited to -70 dBW (-40 dBm)/MHz equivalent isotropically radiated power (EIRP) for wideband signals. and -80 dBW (-50 dBm) EIRP for discrete emissions of less than 700 Hz bandwidth.

RSS-130 Clause 4.7.

The unwanted emissions in any 100 kHz bandwidth on any frequency outside the low frequency edge and the high frequency edge of each frequency block range(s), shall be attenuated below the transmitter power, P (dBW), by at least $43 + 10 \log_{10} p$ (watts), dB. However, in the 100 kHz band immediately outside of the equipment's frequency block range, a resolution bandwidth of 30 kHz may be employed.

The power of any unwanted emissions in any 6.25 kHz bandwidth for all frequencies between 763-775 MHz and 793-806 MHz shall be attenuated below the transmitter power. P (dBW). by at least $65 + 10 \log_{10} p$ (watts). dB. for mobile and portable equipment.

The e.i.r.p. in the band 1559-1610 MHz shall not exceed -70 dBW (-40 dBm) /MHz for wideband signal and -80 dBW (-50 dBm) for discrete emission with bandwidth less than 700 Hz.

FCC §27.53 (h). RSS-139 Clause 6.6.

According to specification. the power of emissions shall be attenuated below the transmitter power (P) by a factor of at least $43 + 10 \log (P)$ dB. P in watts.

At P_o transmitting power. the specified minimum attenuation becomes $43+10 \log (P_o)$. and the level in dBm relative P_o becomes:

P_o (dBm) – $[43 + 10 \log (P_o \text{ in mwatts}) - 30] = -13$ dBm.

METHOD

The measurement was performed with the EUT inside an anechoic chamber. The spectrum was scanned from 30 MHz to at least the 10th harmonic of the highest frequency generated within the equipment.

The EUT was placed on a non-conductive stand at a 3 meter distance from the measuring antenna for measurements below 1 GHz and at 1 m distance for measurements above 1 GHz.

Detected emissions were maximized at each frequency by rotating the EUT and adjusting the measuring antenna height and polarization. The maximum field strength (dB μ V/m) is measured and recorded.

The maximum field strength (dB μ V/m) of each detected emission at less than 20 dB respect to the limit is converted to an equivalent EIRP level (dBm) according to ANSI C63.26 with the formula:

$EIRP \text{ (dBm)} = E \text{ (dB}\mu\text{V/m)} + 20\log(D) - 104.8$; where D is the measurement distance (in the far field region) in m. $D = 3 \text{ m}$

TEST SETUP

Radiated measurements below 1 GHz.

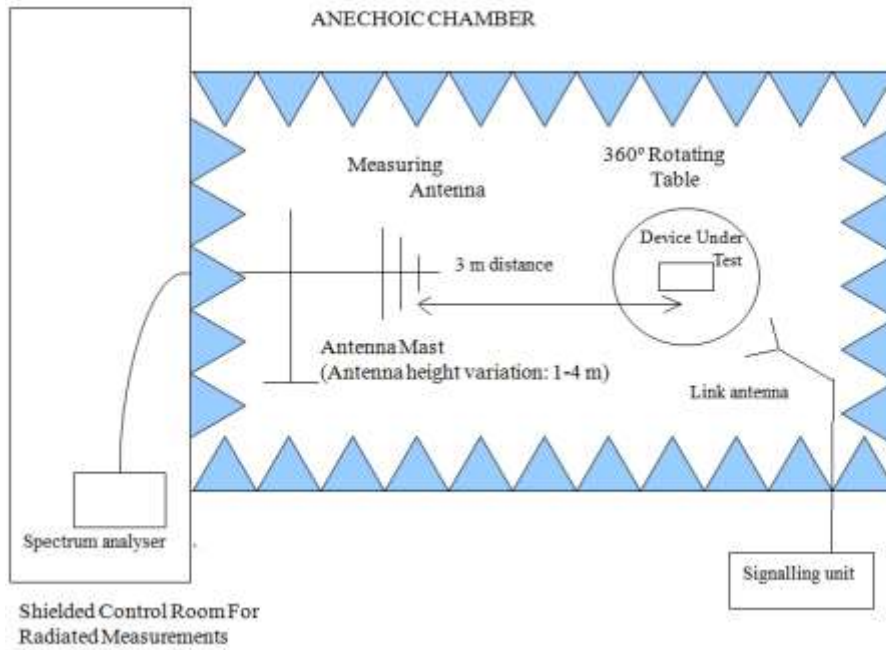

Radiated measurements above 1 GHz.

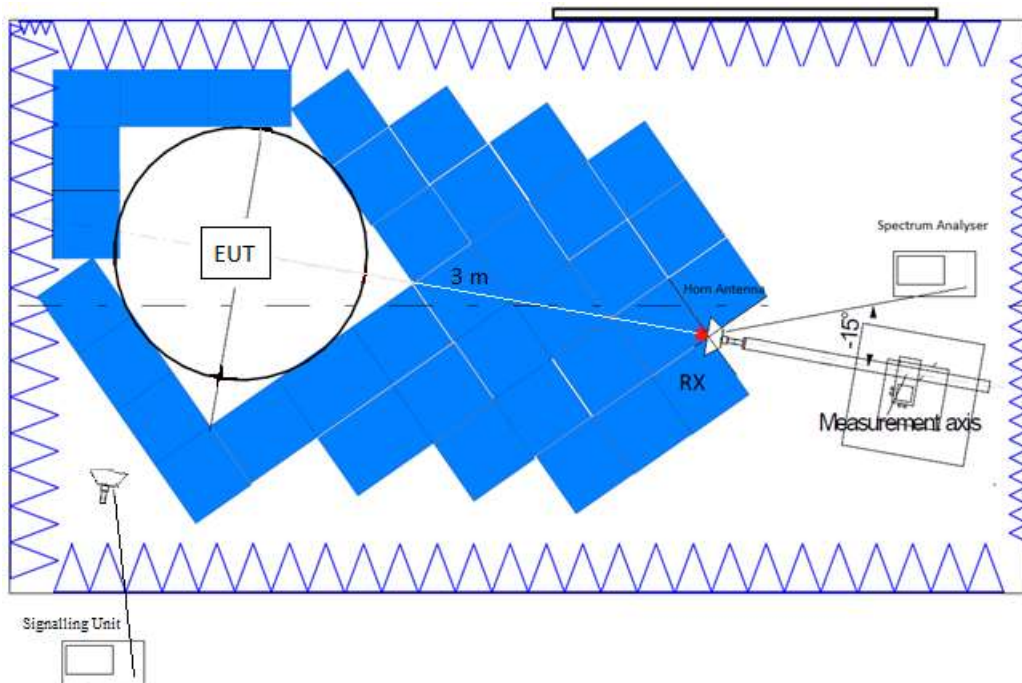

Radiated measurements above 18 GHz.

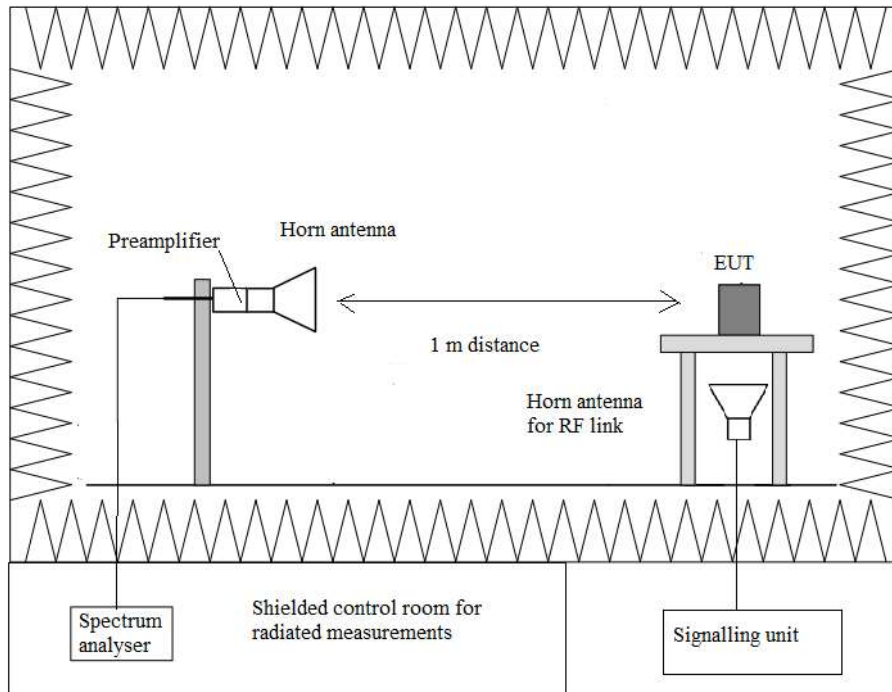

RESULTS

NB IoT. BAND 12.

Preliminary measurements determined that 1 tone of 15kHz ($\pi/4$ – QPSK) as the worst case. The results in the next tables shows the results for this configuration.

1. CHANNEL: LOWEST

Frequency range 30 MHz-1000 MHz.

No radiated spurious signals were detected.

Frequency range 1 GHz-8 GHz.

No radiated spurious signals were detected at less than 20 dB respect to the limit.

2. CHANNEL: MIDDLE

Frequency range 30 MHz-1000 MHz.

No radiated spurious signals were detected.

Frequency range 1 GHz-8 GHz.

No radiated spurious signals were detected at less than 20 dB respect to the limit.

3. CHANNEL: HIGHEST

Frequency range 30 MHz-1000 MHz.

No radiated spurious signals were detected.

Frequency range 1 GHz-8 GHz.

No radiated spurious signals were detected at less than 20 dB respect to the limit.

Measurement uncertainty (dB)	< \pm 4.65 for $f < 1$ GHz < \pm 4.98 for $f \geq 1$ GHz up to 8 GHz
------------------------------	---

Verdict: PASS

NBLoT. BAND 13.

Preliminary measurements determined that 1 tone of 15kHz ($\pi/4$ – QPSK) as the worst case. The results in the next tables shows the results for this configuration.

1. CHANNEL: LOWEST

Frequency range 30 MHz-1000 MHz.

No radiated spurious signals were detected at less than 20 dB respect to the limit.

Frequency range 1 GHz-8 GHz.

No radiated spurious signals were detected at less than 20 dB respect to the limit.

Frequency range 1559 MHz-1610 MHz.

No radiated spurious signals were detected at less than 20 dB respect to the limit.

2. CHANNEL: MIDDLE

Frequency range 30 MHz-1000 MHz.

No radiated spurious signals were detected.

Frequency range 1 GHz-8 GHz.

No radiated spurious signals were detected at less than 20 dB respect to the limit.

Frequency range 1559 MHz-1610 MHz.

Spurious frequency (MHz)	Detector	E.I.R.P. (dBm)	Polarization
1.563834	RMS	-48.74	H

3. CHANNEL: HIGHEST

Frequency range 30 MHz-1000 MHz.

No radiated spurious signals were detected.

Frequency range 1 GHz-8 GHz.

No radiated spurious signals were detected at less than 20 dB respect to the limit.

Frequency range 1559 MHz-1610 MHz.

Spurious frequency (MHz)	Detector	E.I.R.P. (dBm)	Polarization
1.573561	RMS	-48.08	H

Measurement uncertainty (dB)	< \pm 4.65 for $f < 1$ GHz < \pm 4.98 for $f \geq 1$ GHz up to 8 GHz
------------------------------	---

Verdict: PASS

NBLoT. BAND 66.

Preliminary measurements determined that 1 tone of 3.75kHz as the worst case. The results in the next tables shows the results for this configuration.

1. CHANNEL: LOWEST

Frequency range 30 MHz-1000 MHz.

No radiated spurious signals were detected at less than 20 dB respect to the limit.

Frequency range 1 GHz-18 GHz.

No radiated spurious signals were detected at less than 20 dB respect to the limit.

2. CHANNEL: MIDDLE

Frequency range 30 MHz-1000 MHz.

No radiated spurious signals were detected at less than 20 dB respect to the limit.

Frequency range 1 GHz-18 GHz.

No radiated spurious signals were detected at less than 20 dB respect to the limit.

3. CHANNEL: HIGHEST

Frequency range 30 MHz-1000 MHz.

No radiated spurious signals were detected at less than 20 dB respect to the limit.

Frequency range 1 GHz-18 GHz.

No radiated spurious signals were detected at less than 20 dB respect to the limit.

Measurement uncertainty (dB)	<±4.65 for f < 1GHz
	<±3.98 for f ≥ 1 GHz up to 3 GHz
	<±4.98 for f ≥ 3 GHz up to 18 GHz

Verdict: PASS

NBLoT. BAND 85.

Preliminary measurements determined that 1 tone of 15kHz ($\pi/4$ – QPSK) as the worst case. The results in the next tables shows the results for this configuration.

1. CHANNEL: LOWEST

Frequency range 30 MHz-1000 MHz.

No radiated spurious signals were detected.

Frequency range 1 GHz-8 GHz.

No radiated spurious signals were detected at less than 20 dB respect to the limit.

2. CHANNEL: MIDDLE

Frequency range 30 MHz-1000 MHz.

No radiated spurious signals were detected.

Frequency range 1 GHz-8 GHz.

No radiated spurious signals were detected at less than 20 dB respect to the limit.

3. CHANNEL: HIGHEST

Frequency range 30 MHz-1000 MHz.

No radiated spurious signals were detected.

Frequency range 1 GHz-8 GHz.

No radiated spurious signals were detected at less than 20 dB respect to the limit.

Measurement uncertainty (dB)	< \pm 4.65 for $f < 1$ GHz < \pm 4.98 for $f \geq 1$ GHz up to 8 GHz
------------------------------	---

Verdict: PASS

NB IoT Band 12

Frequency range 30 MHz to 1 GHz

CHANNEL: LOWEST

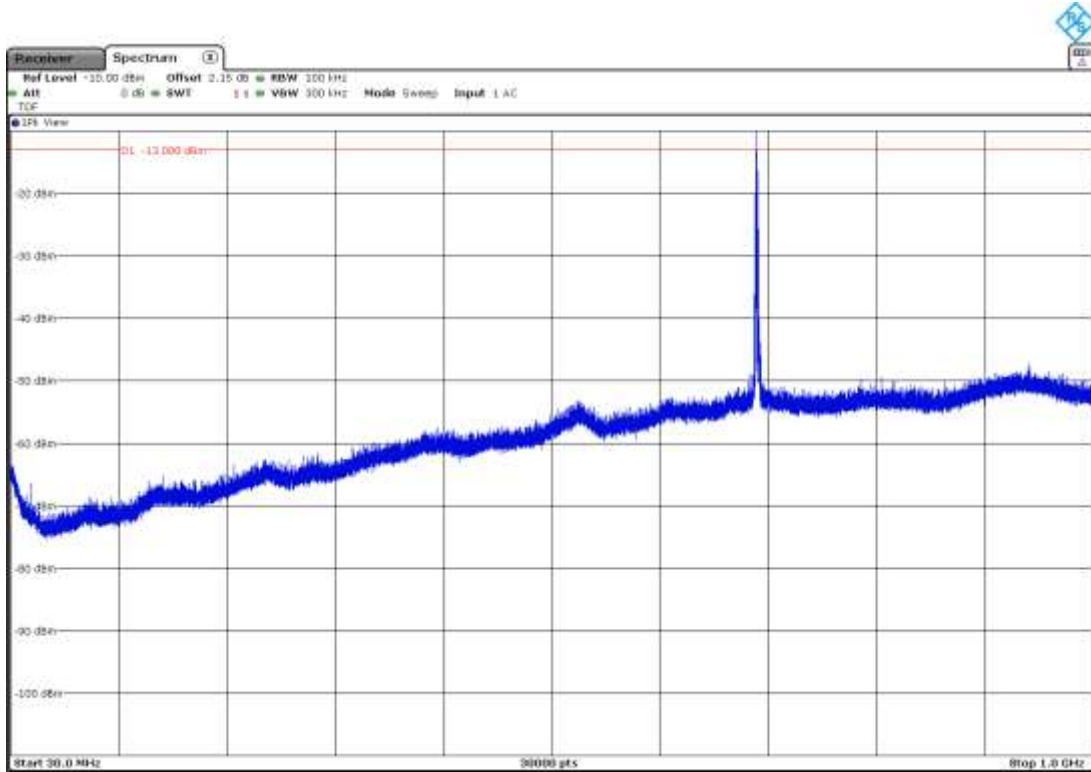

Note: The peak above the limit is the carrier frequency.

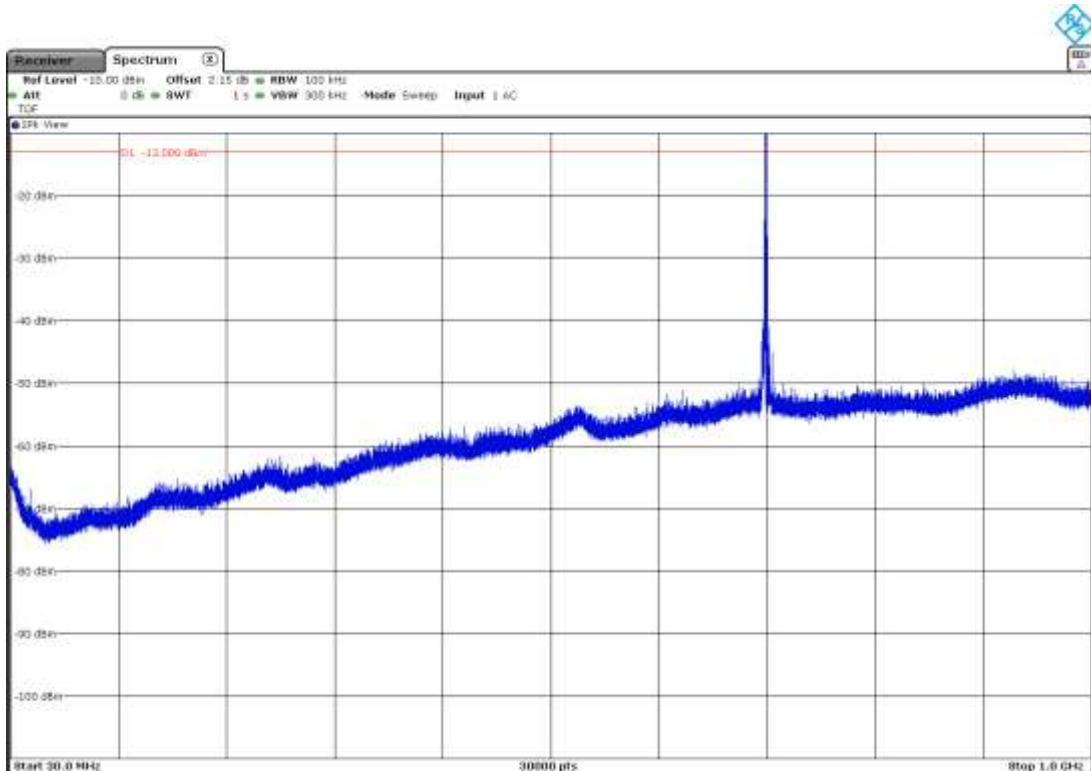

Note: The peak above the limit is the carrier frequency.

CHANNEL: HIGHEST

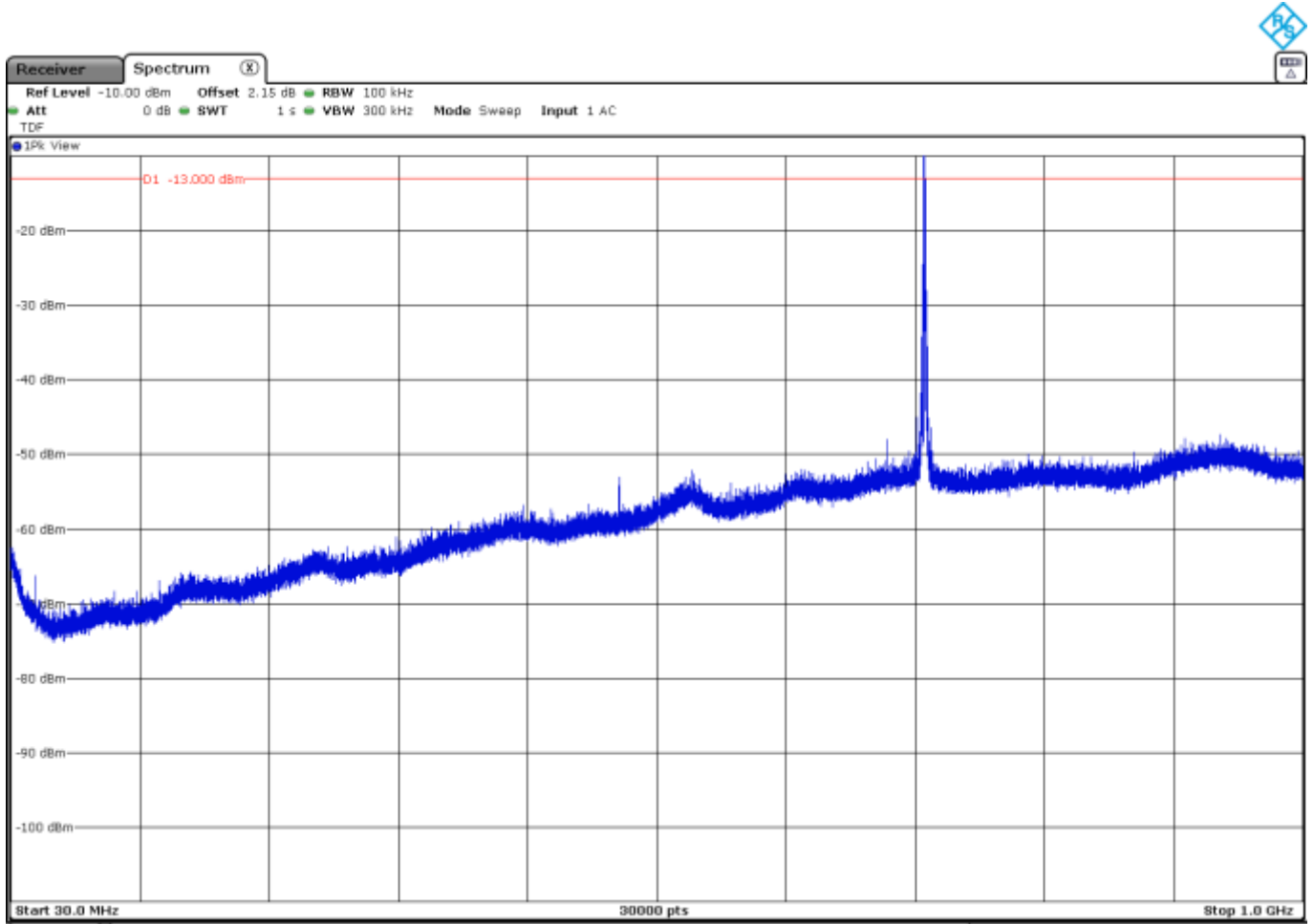

Note: The peak above the limit is the carrier frequency.

Frequency range 1 GHz to 8 GHz

CHANNEL: LOWEST

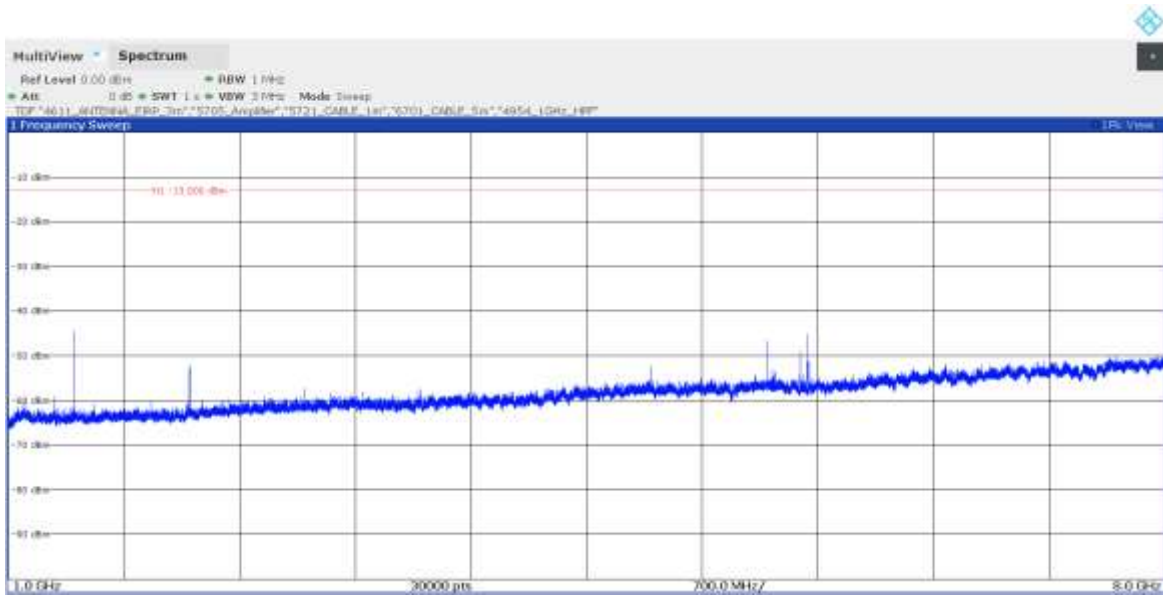

CHANNEL: MIDDLE

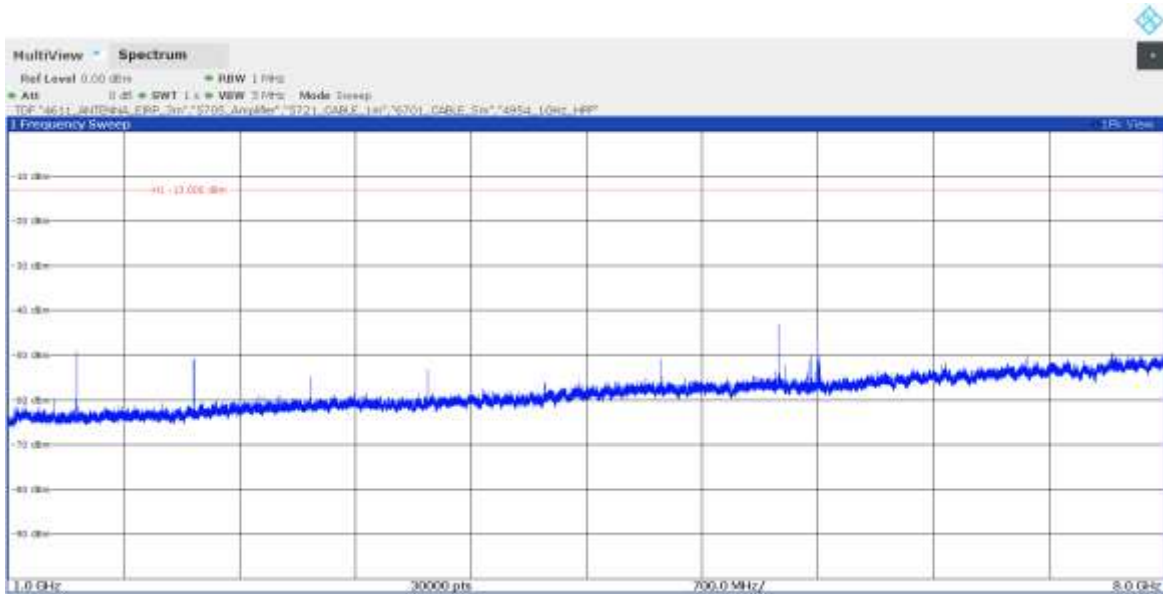

CHANNEL: HIGHEST

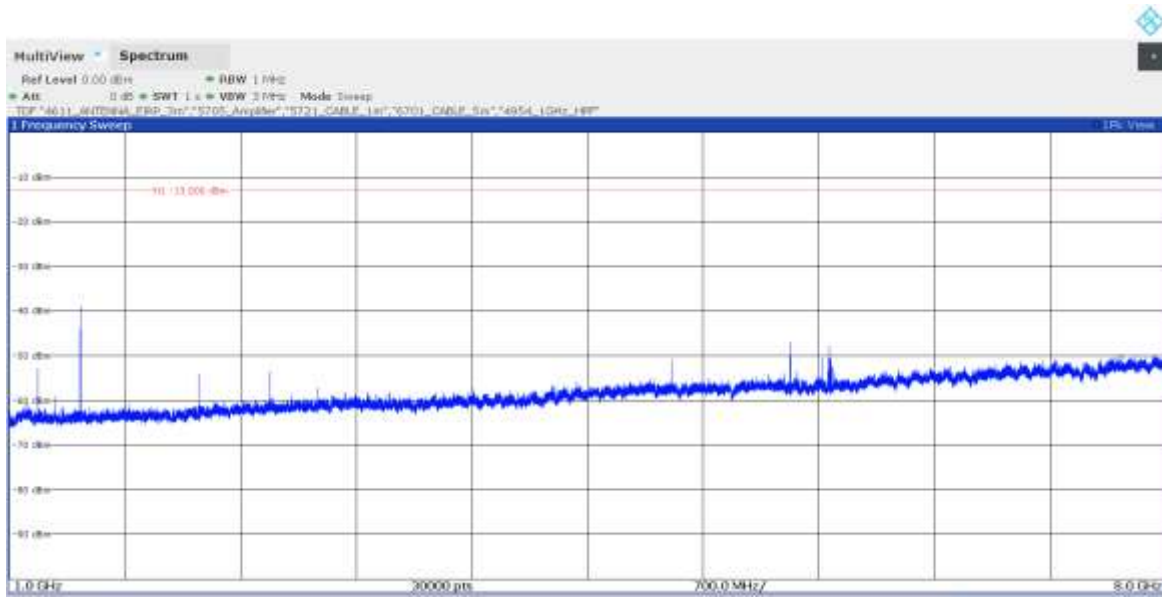

NB-IoT Band 13

Frequency range 30 MHz to 1 GHz

CHANNEL: LOWEST

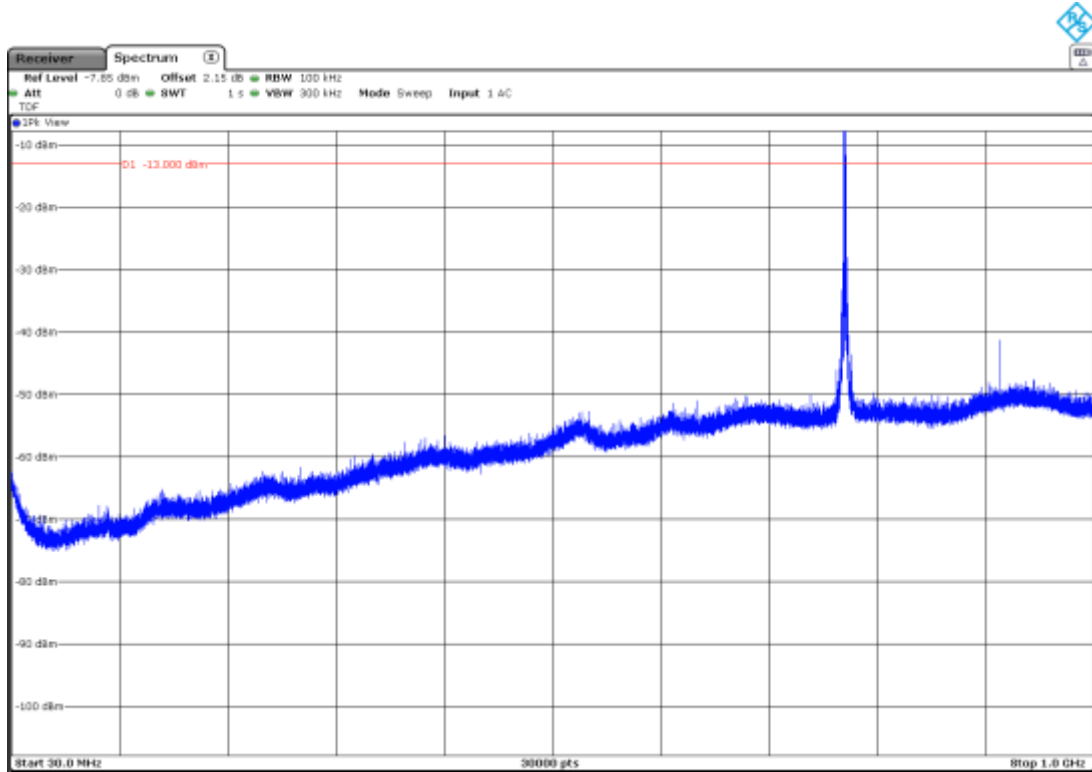

Note: The peak above the limit is the carrier frequency. The peak at 746MHz corresponds to the downlink signal.
CHANNEL: MIDDLE

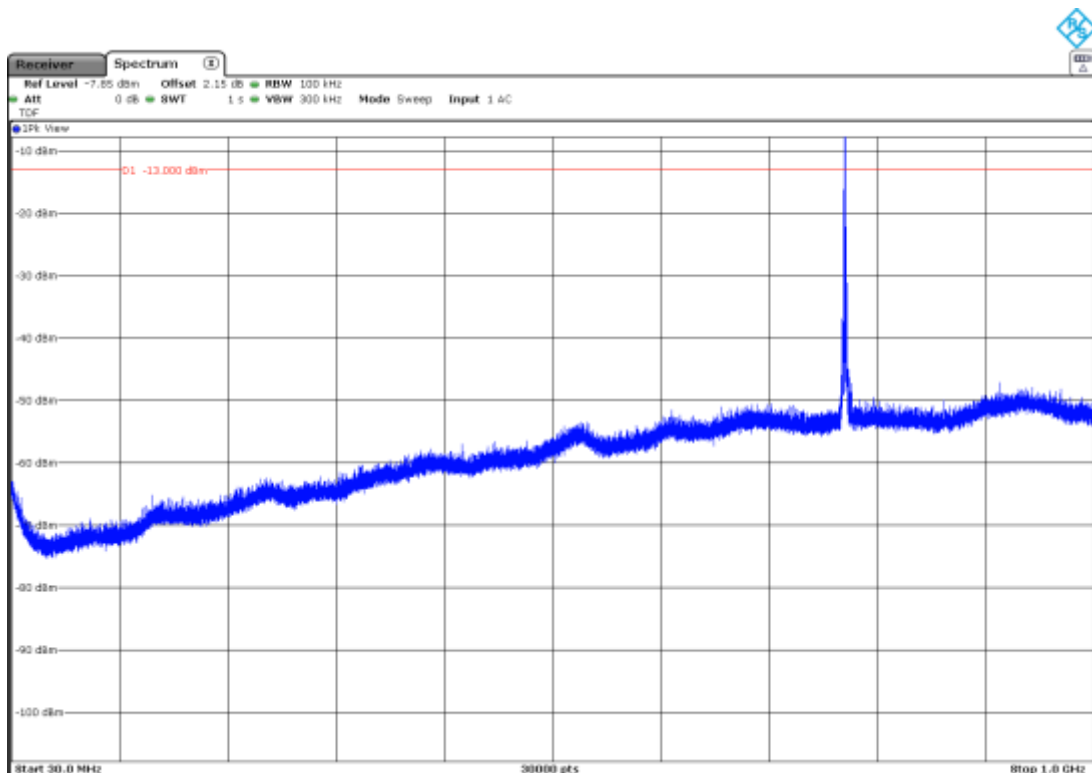

Note: The peak above the limit is the carrier frequency. The peak at 751MHz corresponds to the downlink signal.

CHANNEL: HIGHEST

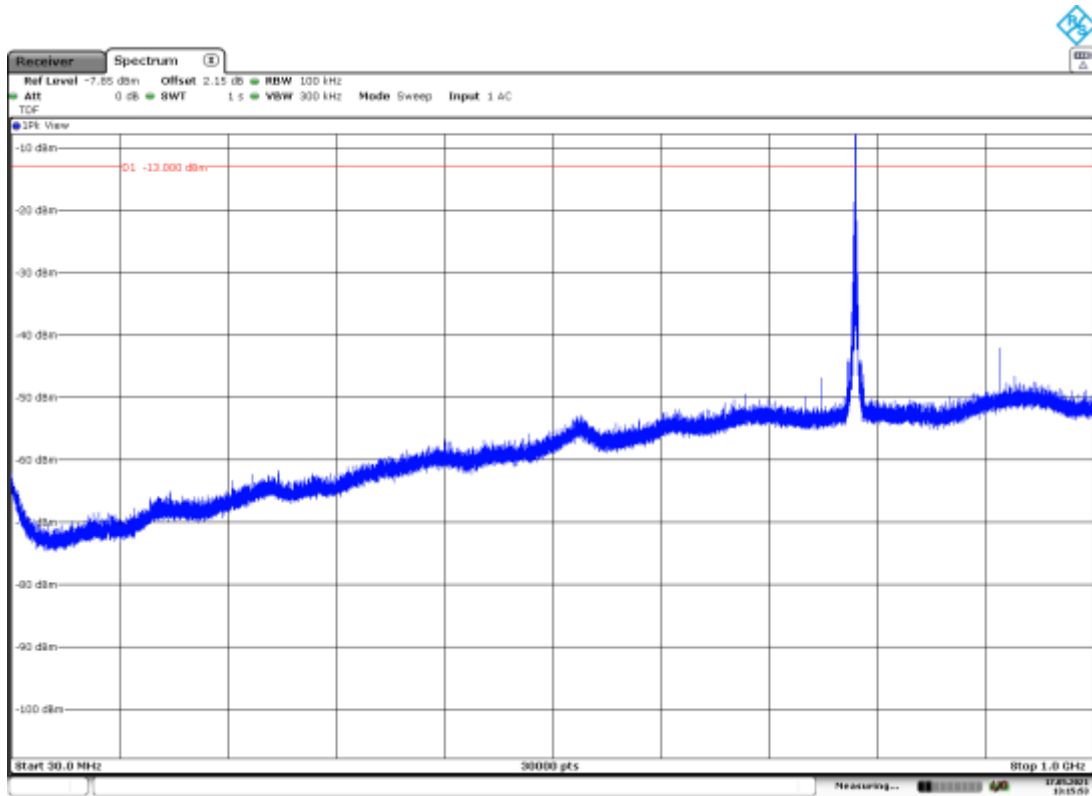

Note: The peak above the limit is the carrier frequency. The peak at 756MHz corresponds to the downlink signal.

Frequency range 1 GHz to 8 GHz

CHANNEL: LOWEST

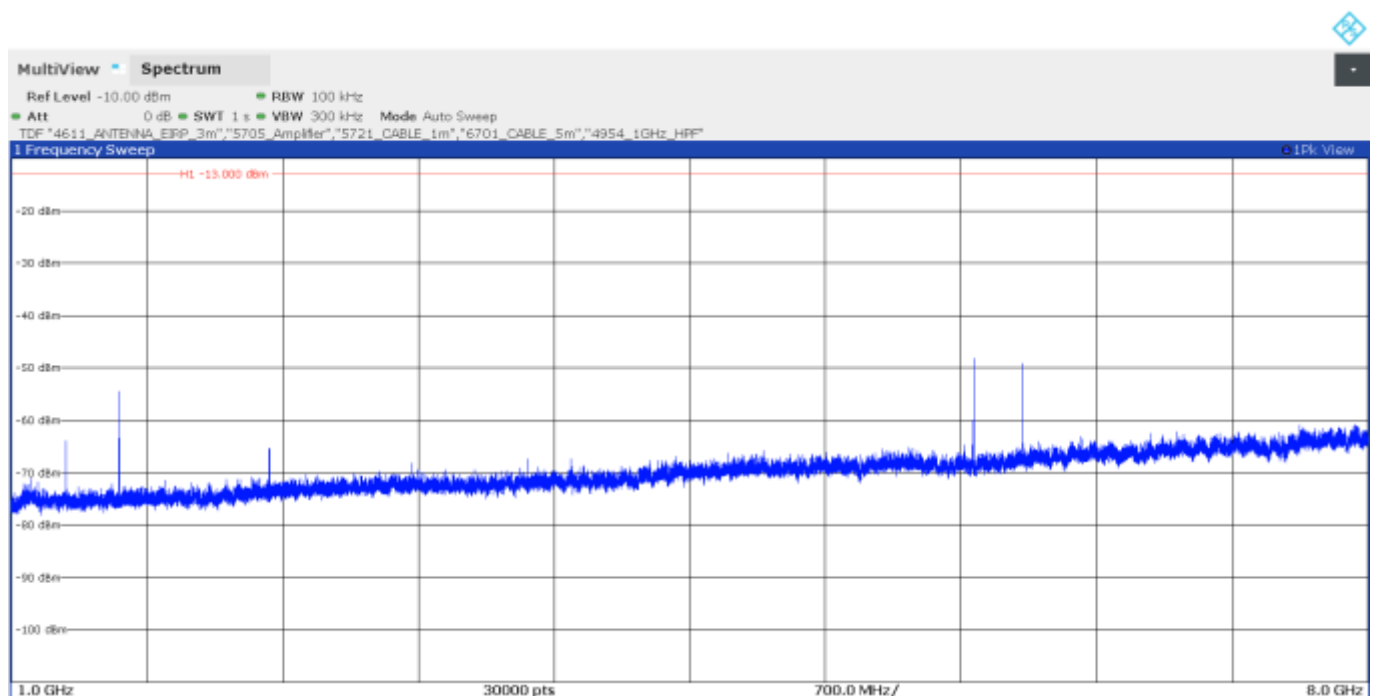

CHANNEL: MIDDLE

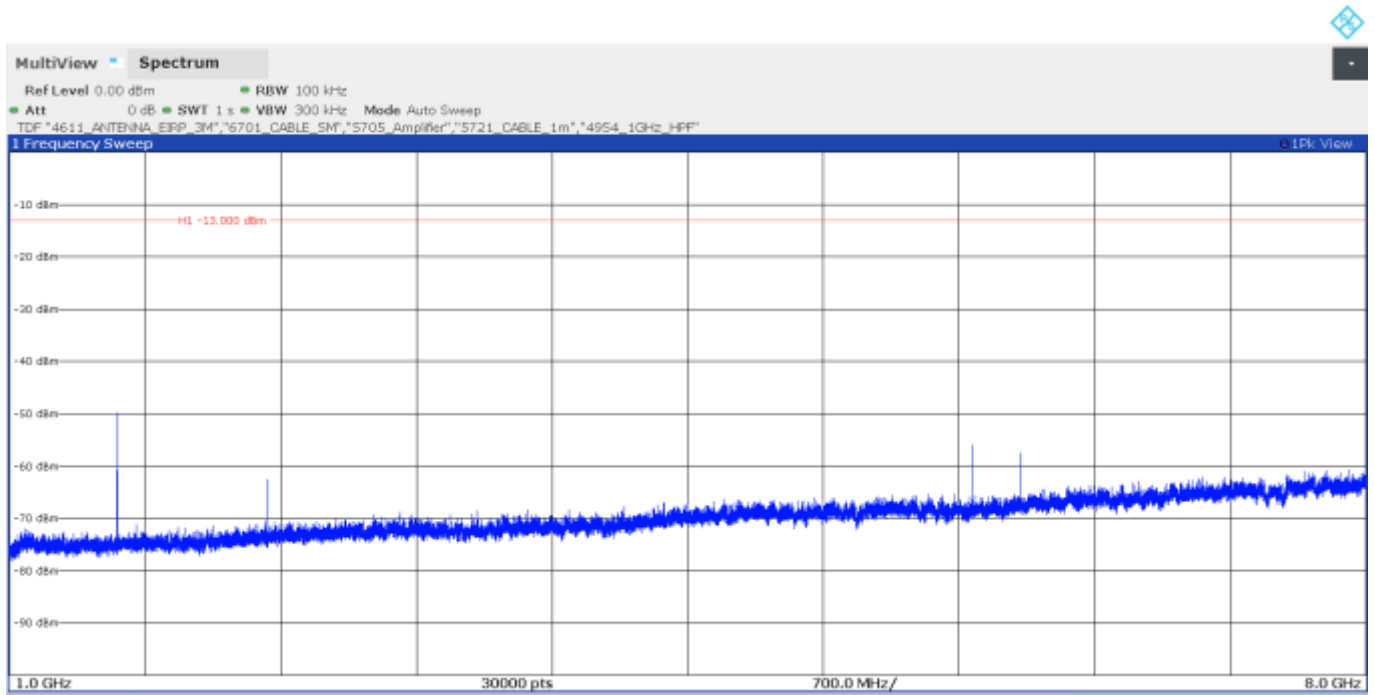

CHANNEL: HIGHEST

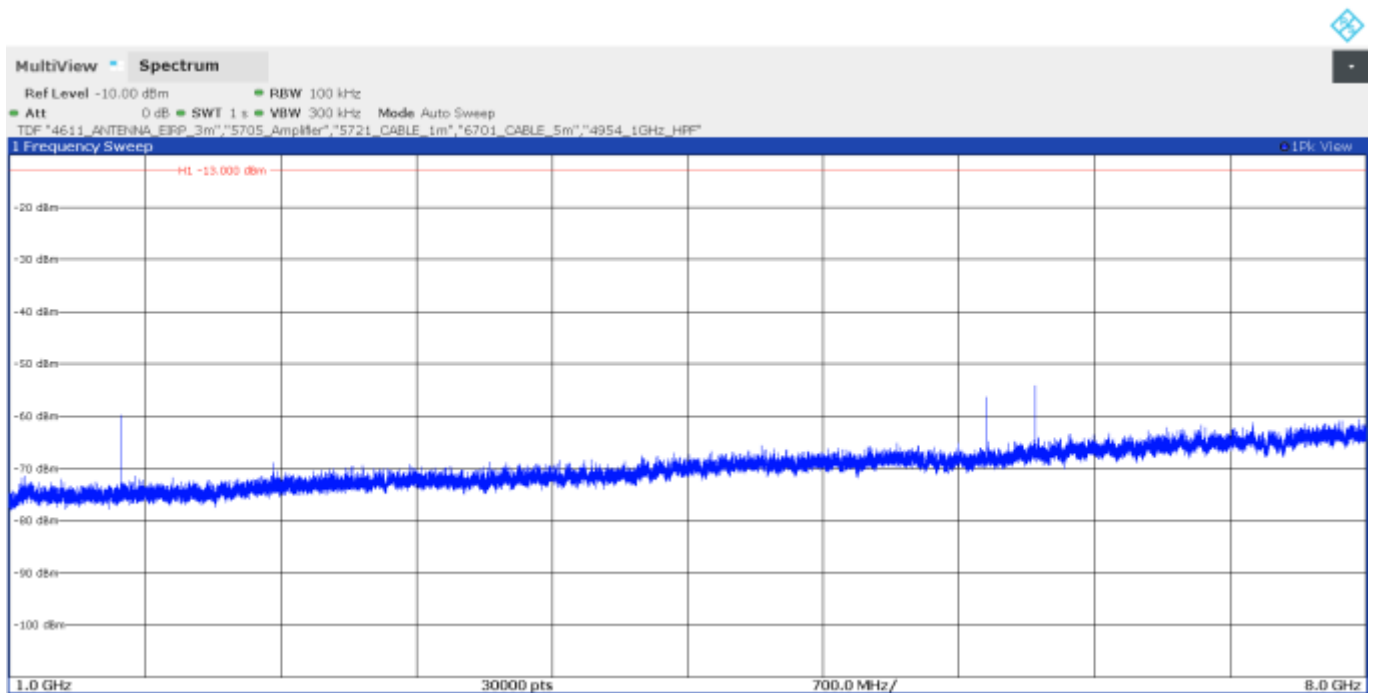

Frequency range 1559 MHz to 1610 MHz.

CHANNEL: LOWEST

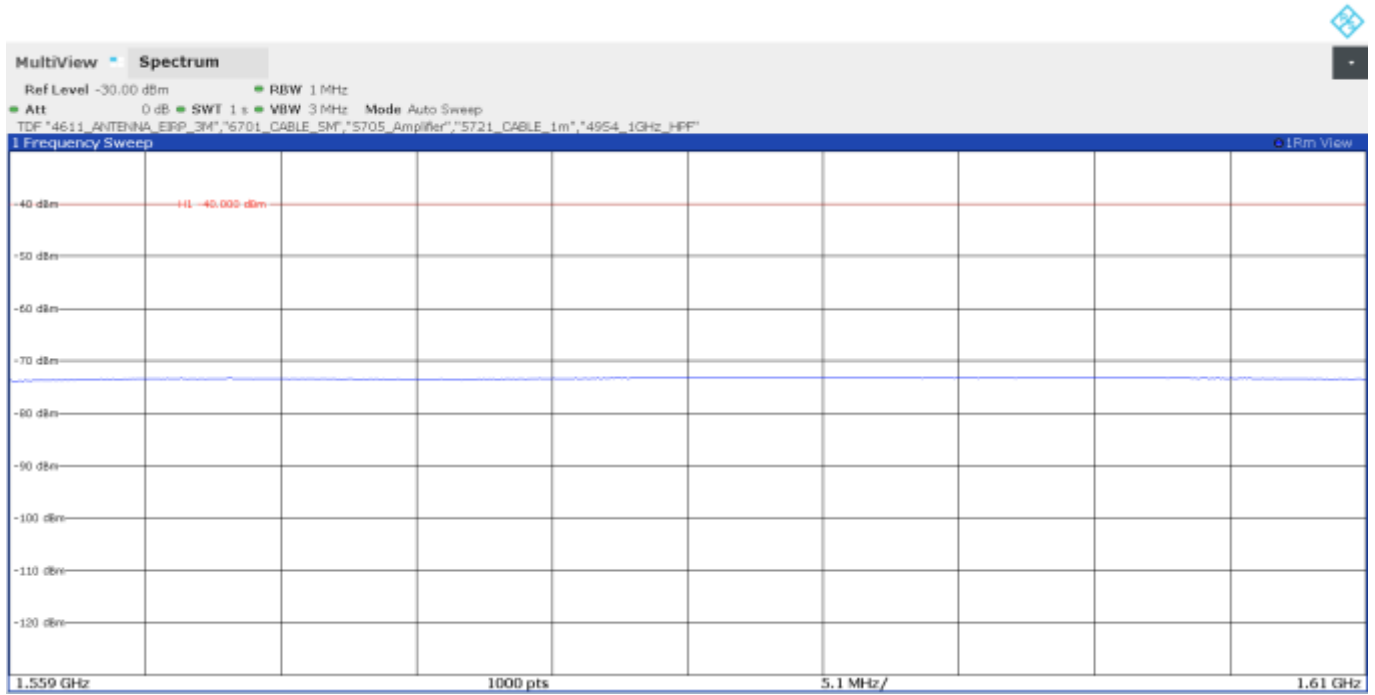

CHANNEL: MIDDLE

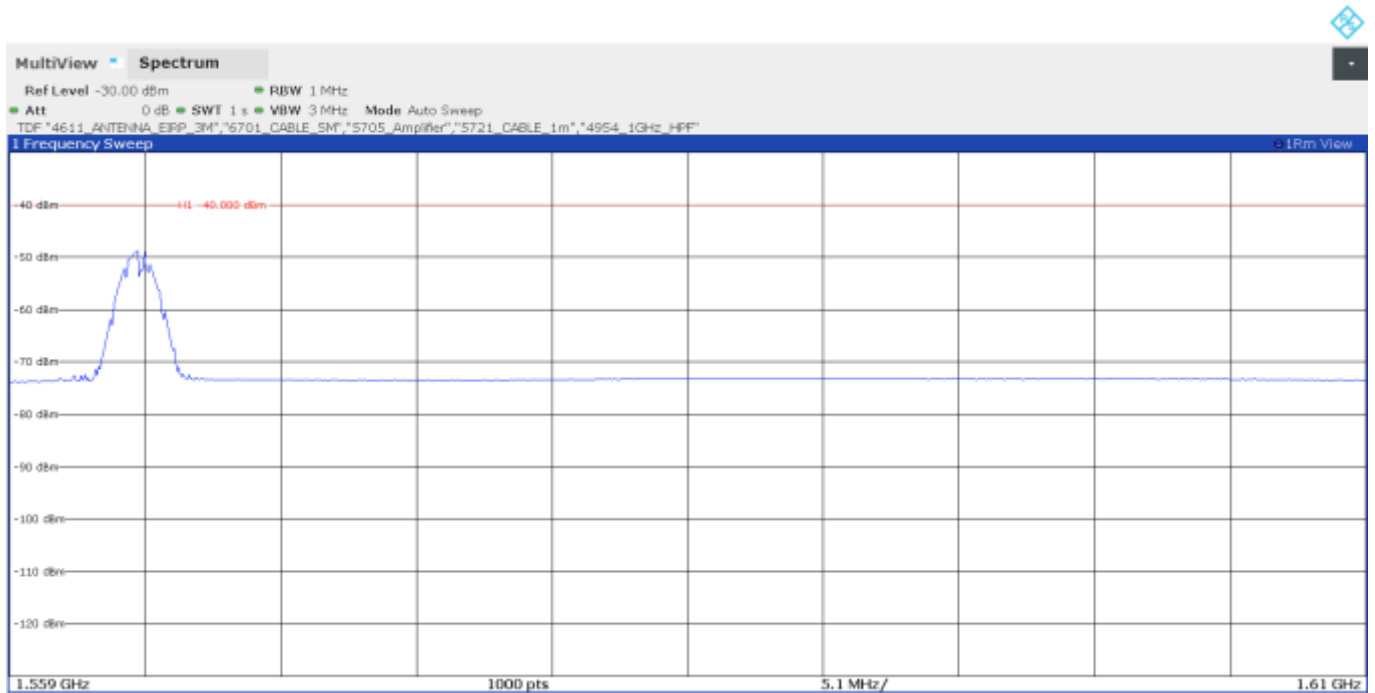

CHANNEL: HIGHEST

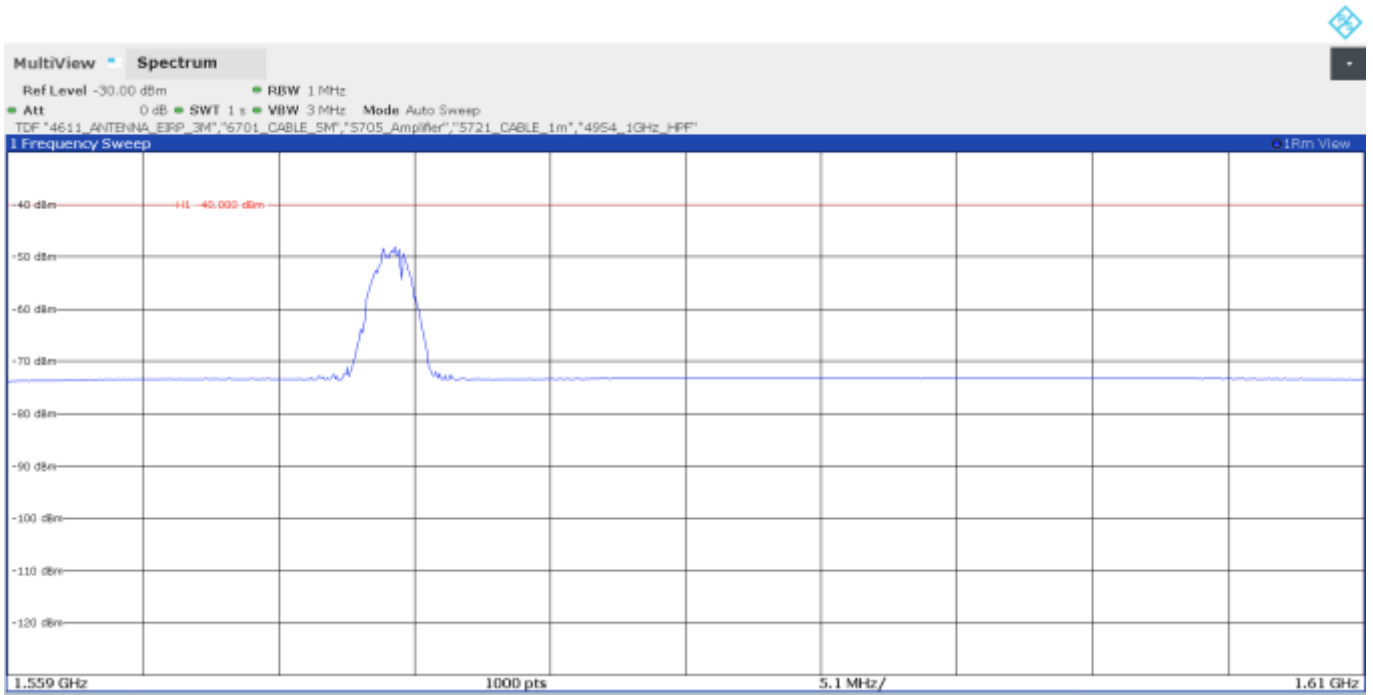

NB-IoT Band 66

Frequency range 30 MHz to 1 GHz

CHANNEL: LOWEST

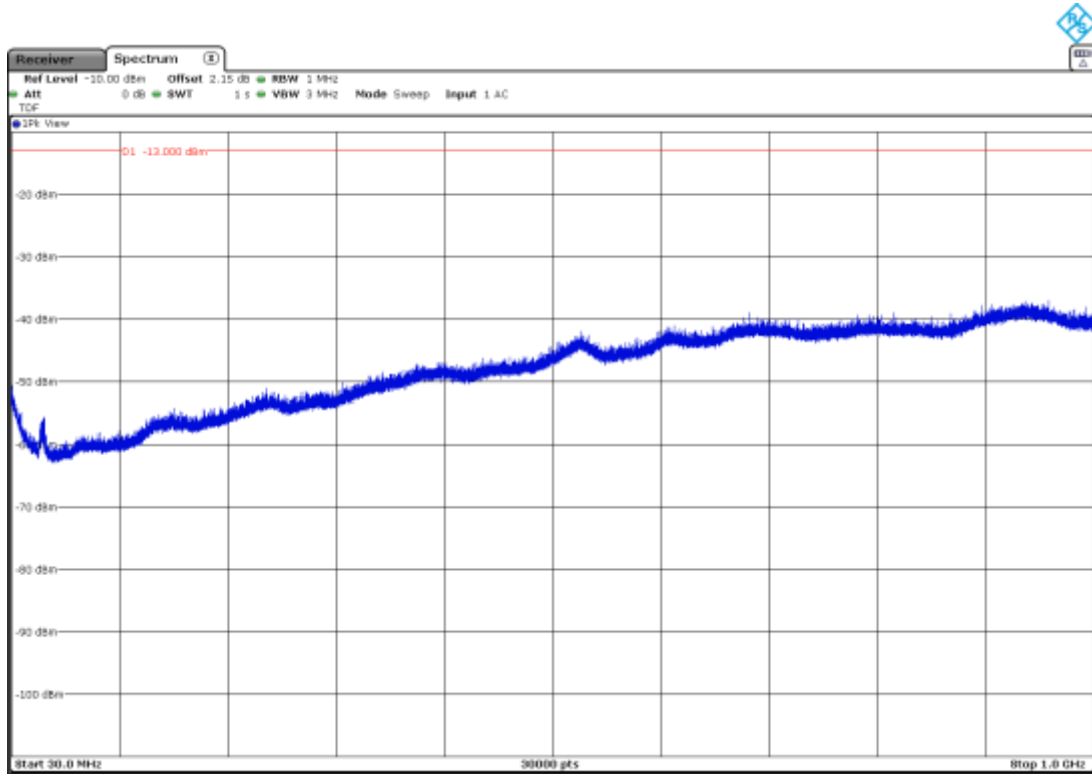

CHANNEL: MIDDLE

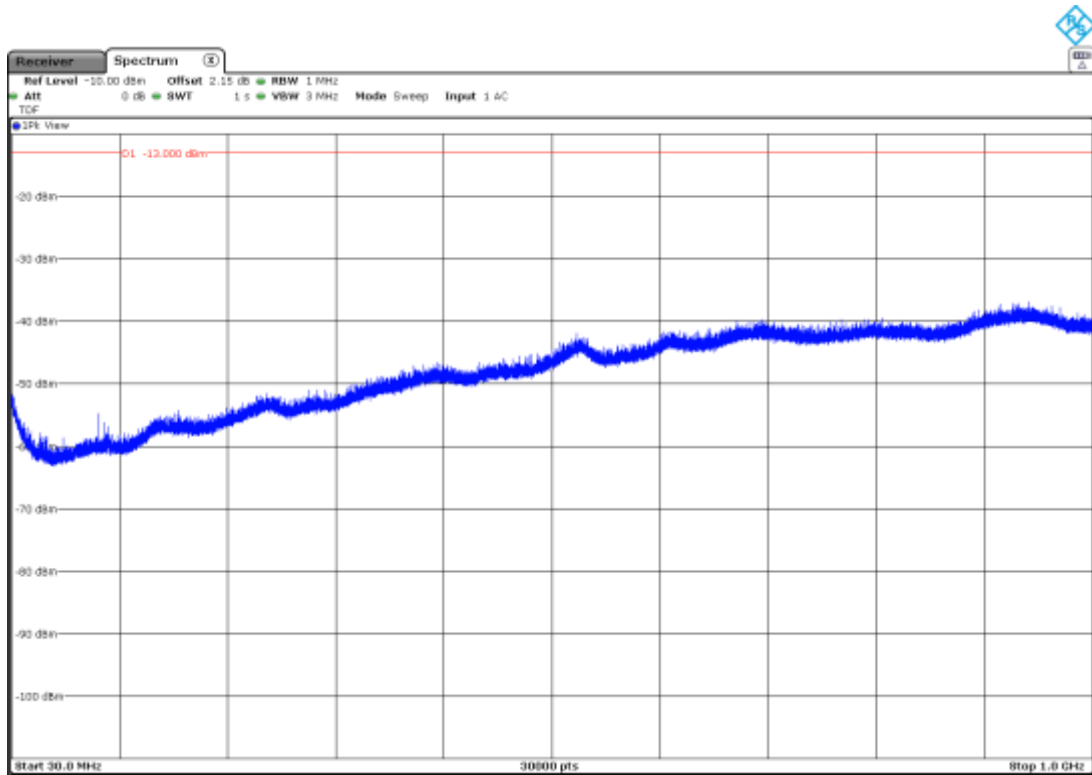

CHANNEL: HIGHEST

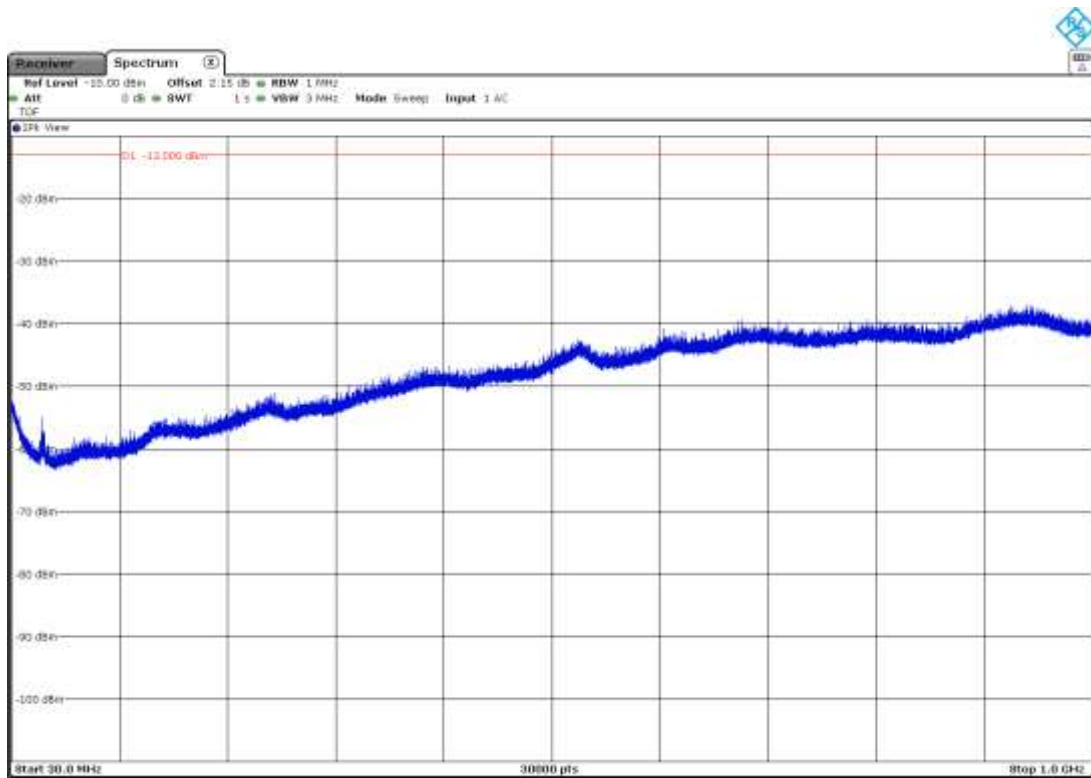

Frequency range 1 GHz to 3 GHz

CHANNEL: LOWEST

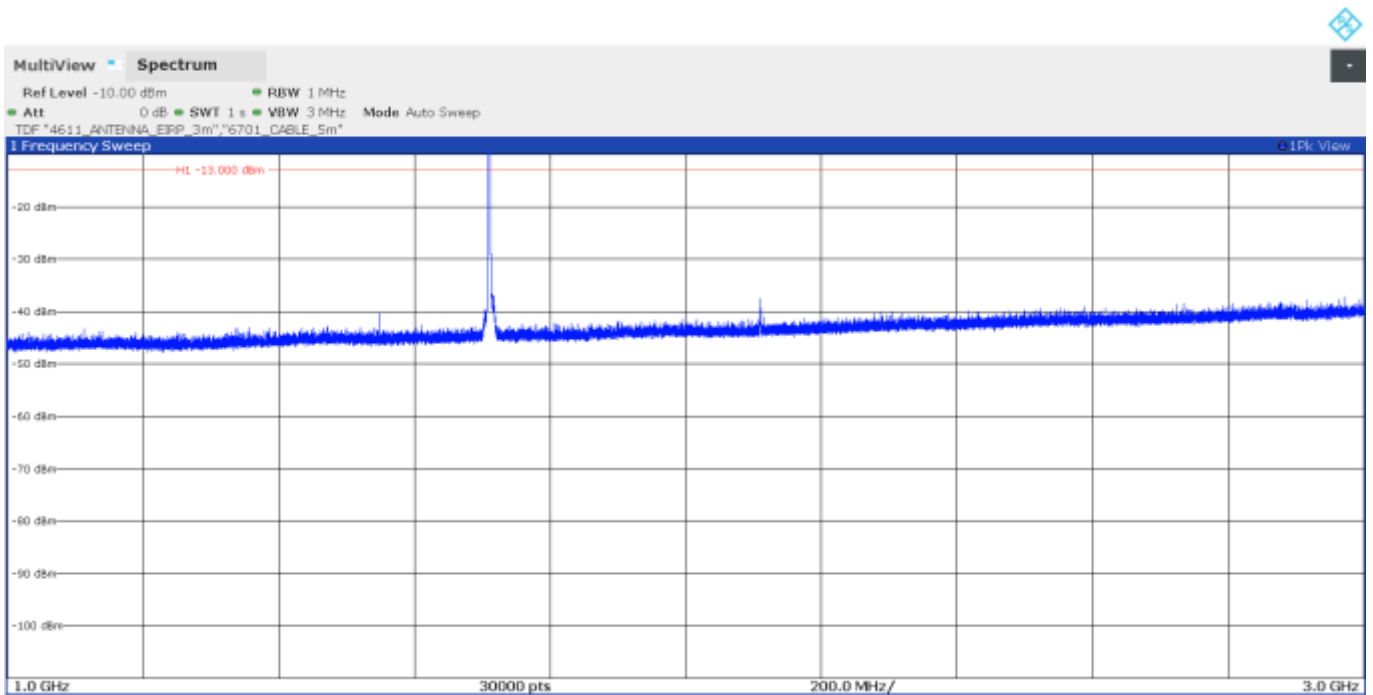

Note: The peak above the limit is the carrier frequency. The peak at 1805MHz corresponds to the downlink signal.

CHANNEL: MIDDLE

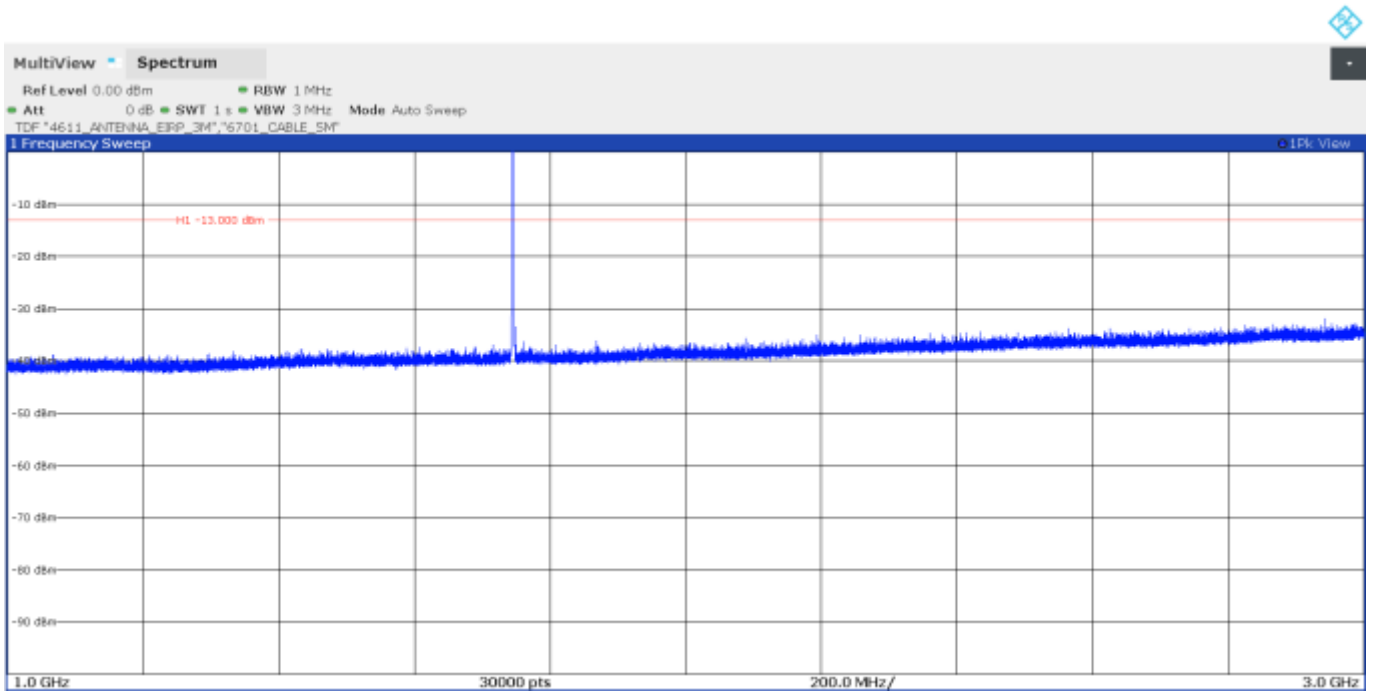

Note: The peak above the limit is the carrier frequency.

CHANNEL: HIGHEST

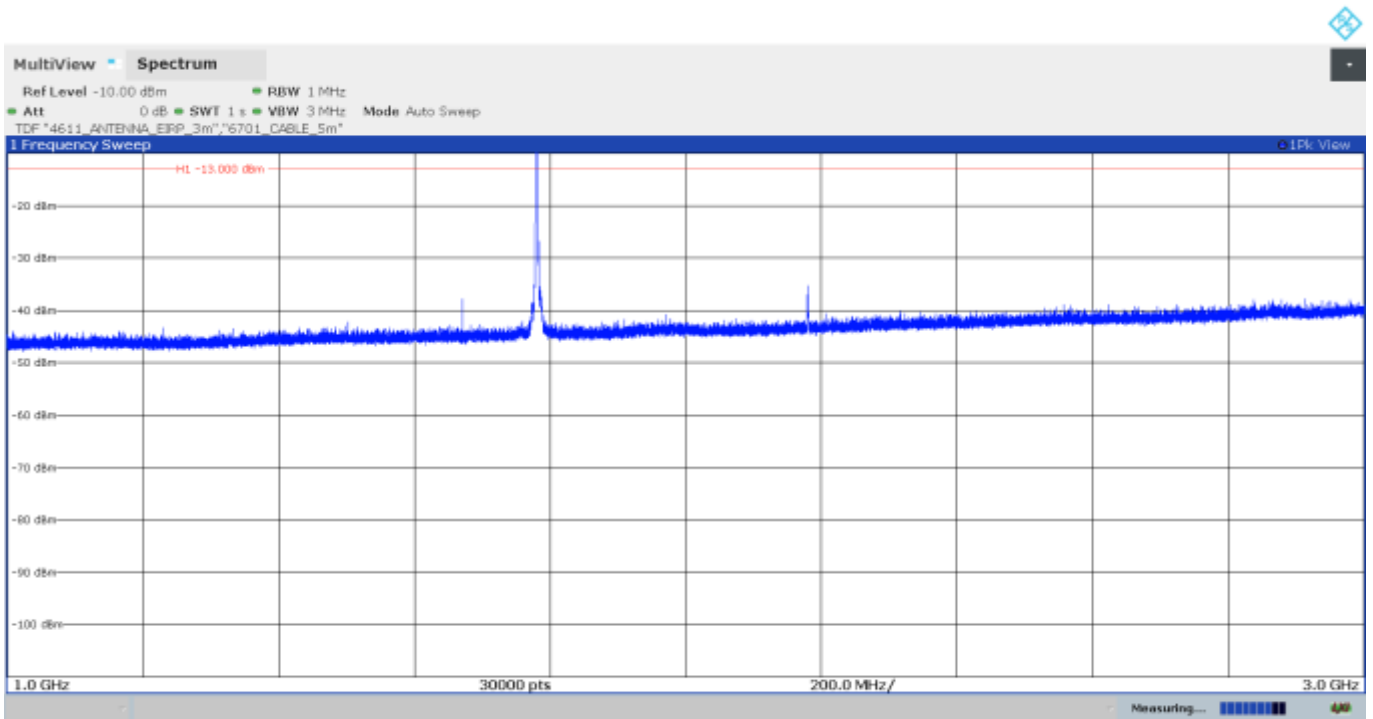

11:02:30 19.03.2021

Note: The peak above the limit is the carrier frequency. The peak at 1875MHz corresponds to the downlink signal.

Frequency range 3 GHz to 18 GHz

CHANNEL: LOWEST

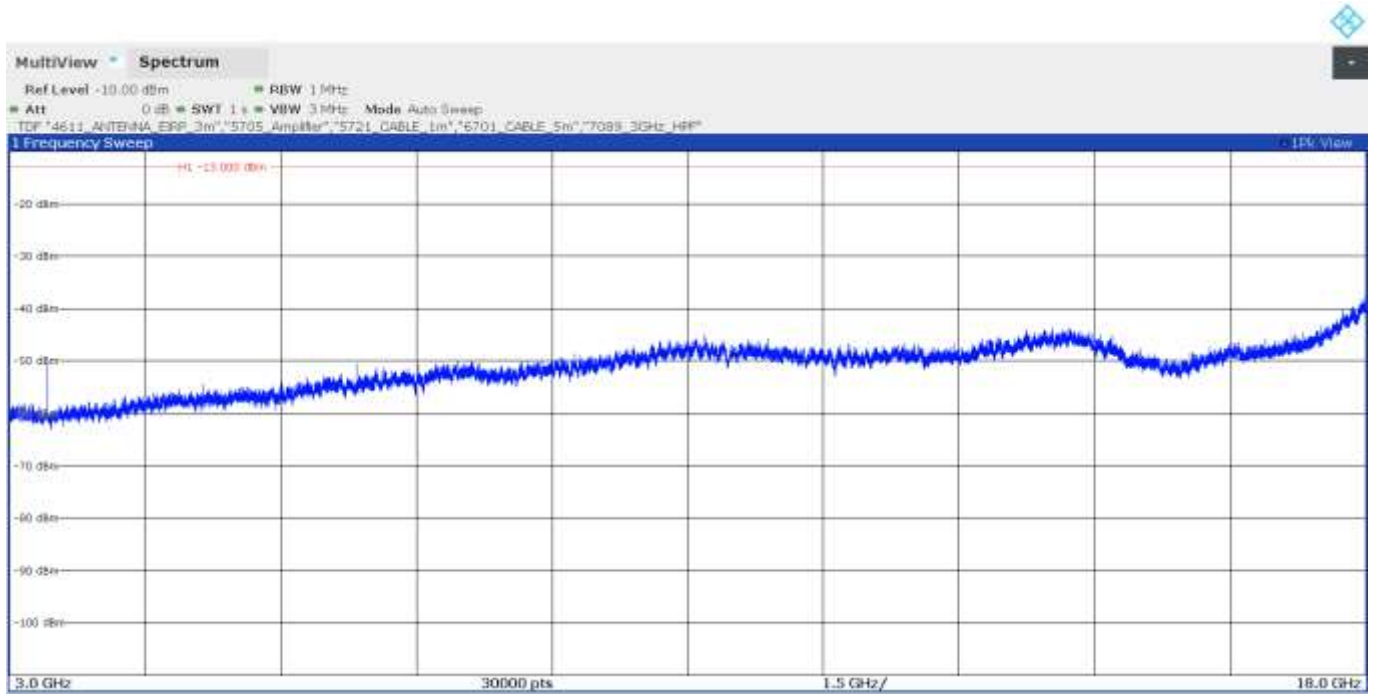

CHANNEL: MIDDLE

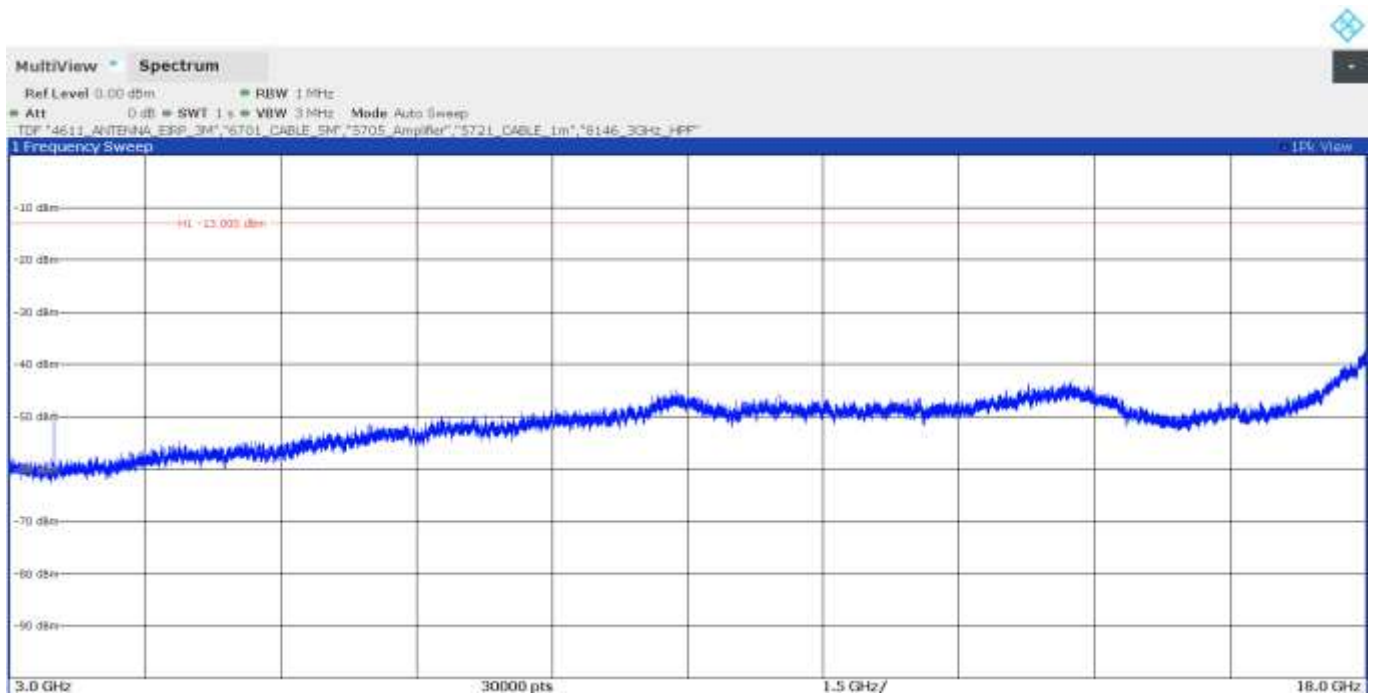

CHANNEL: HIGHEST

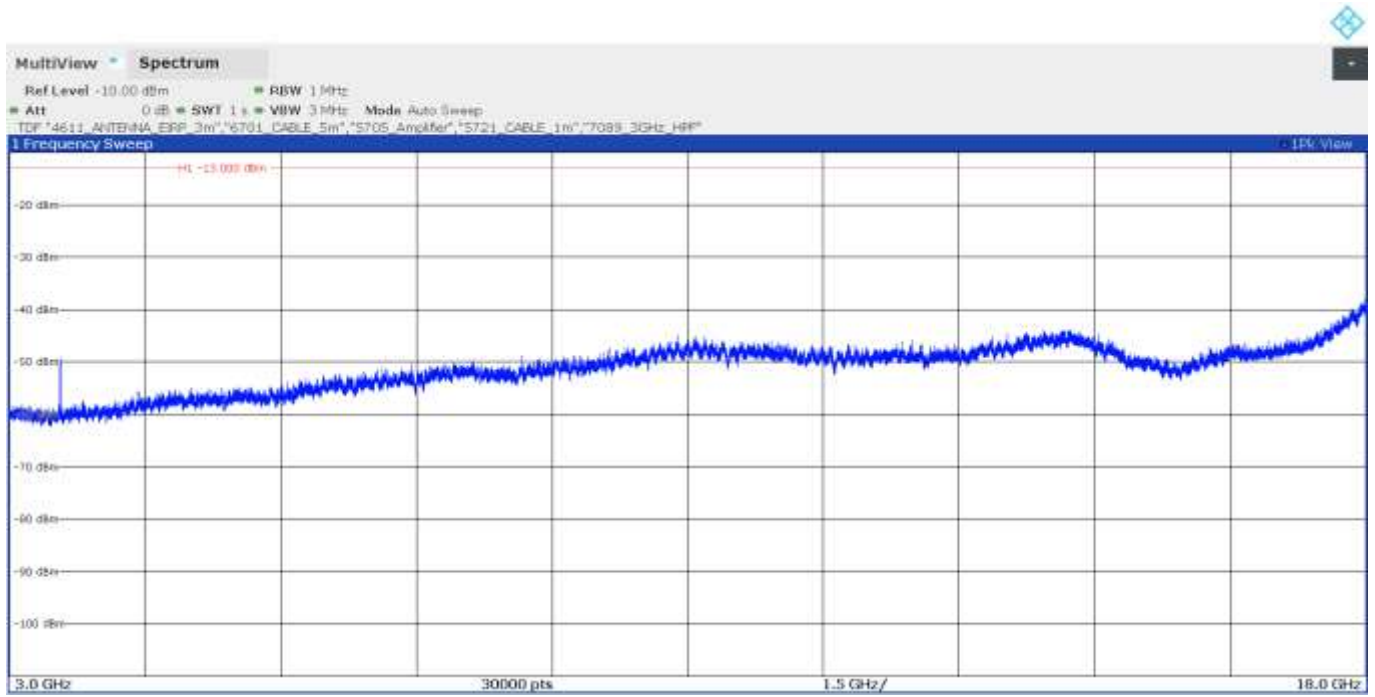

NB IoT Band 85

Frequency range 30 MHz to 1 GHz

CHANNEL: LOWEST

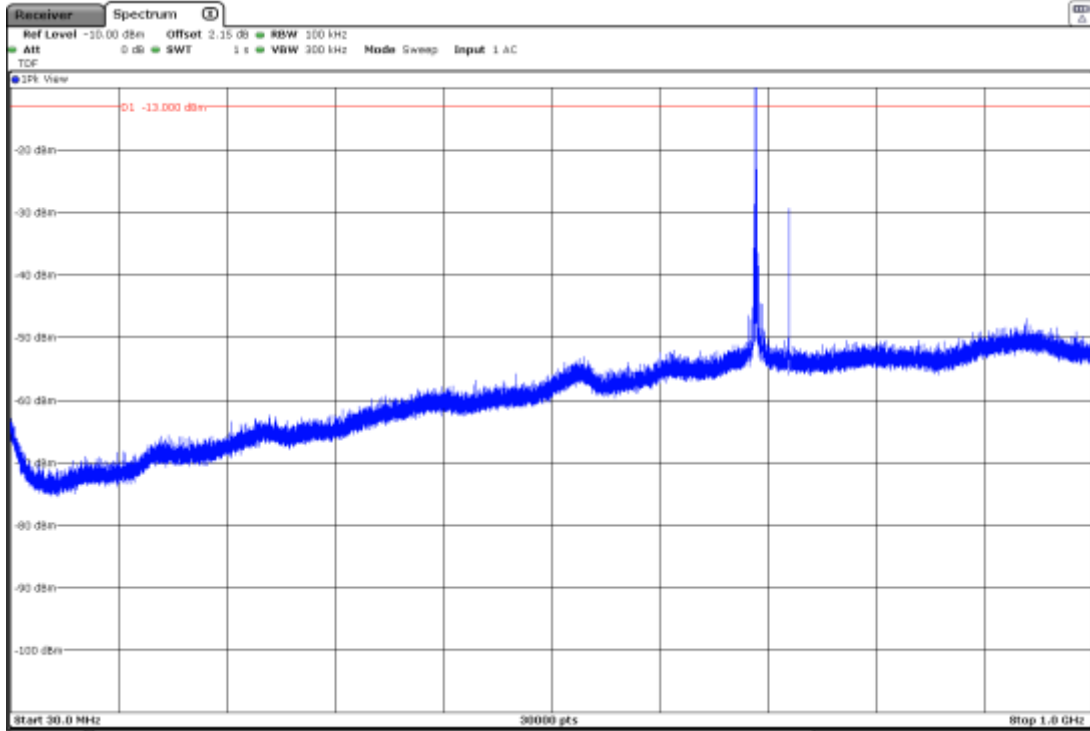

Note: The peak above the limit is the carrier frequency. The peak at 728MHz corresponds to the downlink signal

CHANNEL: MIDDLE

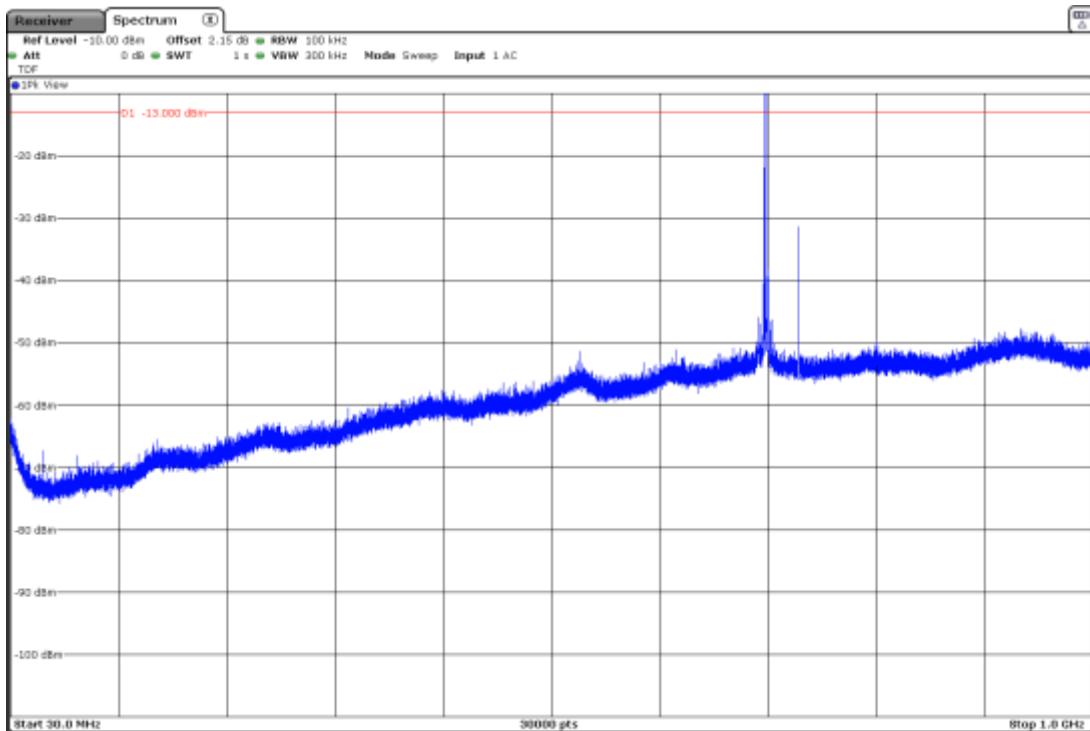

Note: The peak above the limit is the carrier frequency. The peak at 737MHz corresponds to the downlink signal.

CHANNEL: HIGHEST

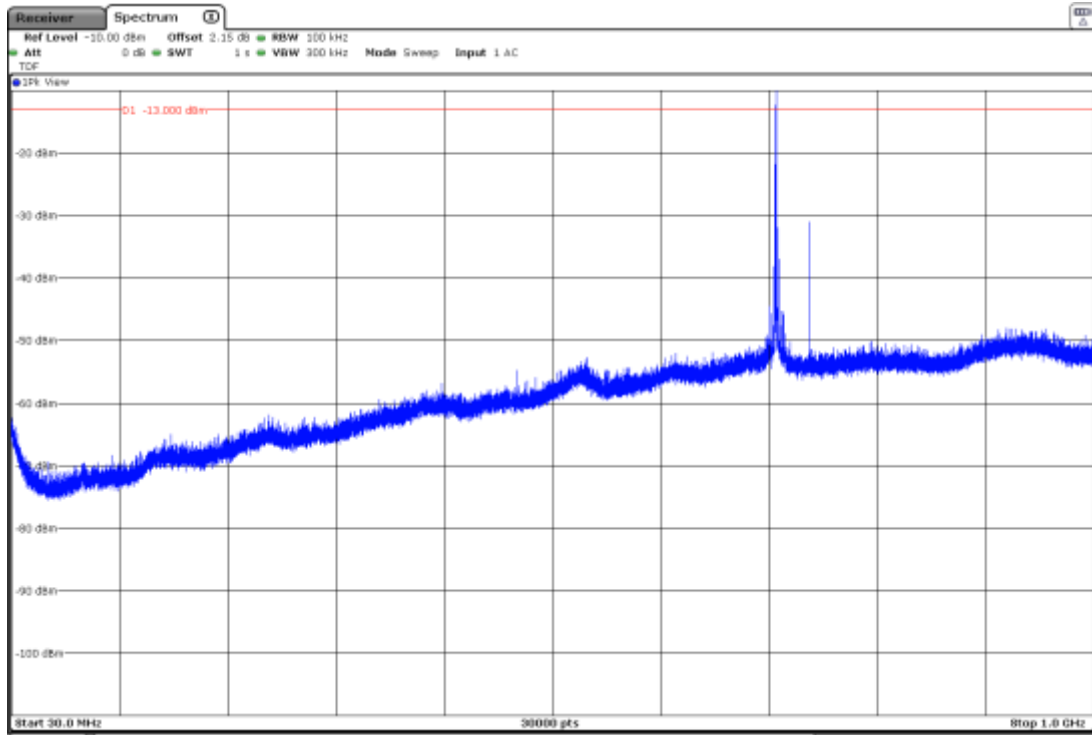

Note: The peak above the limit is the carrier frequency. The peak at 746MHz corresponds to the downlink signal.

Frequency range 1 GHz to 8 GHz

CHANNEL: LOWEST

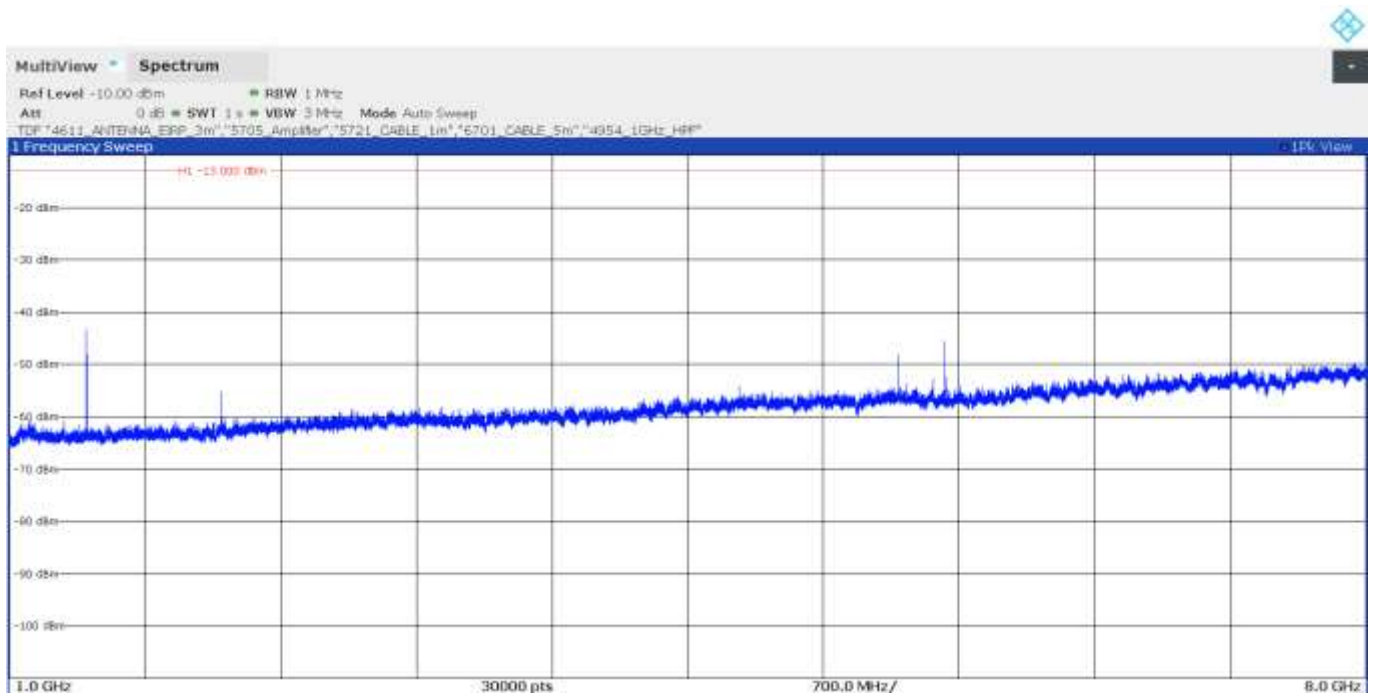

CHANNEL: MIDDLE

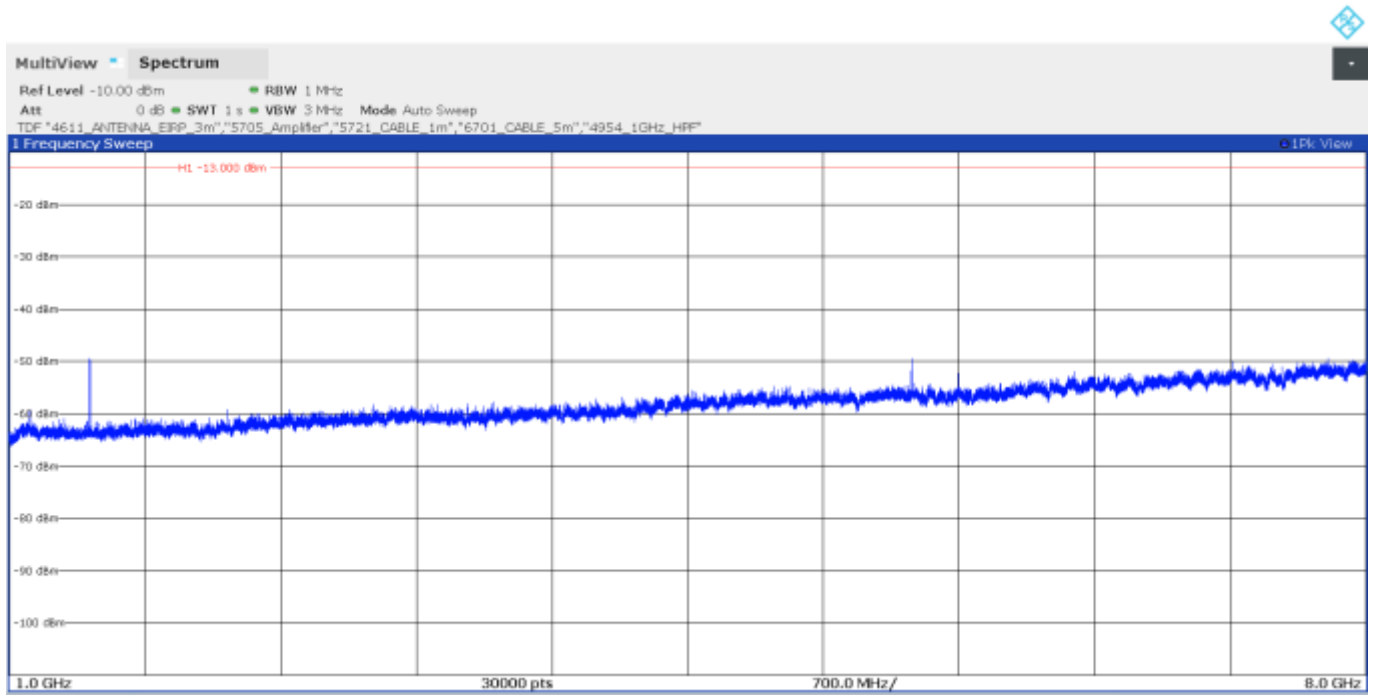

CHANNEL: HIGHEST

