



NE310L2

HW Design Guide

1W0301711 Rev. 2 Preliminary – 2021-07-16

APPLICABILITY TABLE

PRODUCTS
NE310L2-W1
NE310L2-WW

CONTENTS

APPLICABILITY TABLE	2
CONTENTS	3
1. INTRODUCTION	8
1.1. Scope	8
1.2. Audience	8
1.3. Contact Information, Support	8
1.4. Symbol Conventions	9
1.5. Related documents	9
2. GENERAL PRODUCT DESCRIPTION	10
2.1. Overview	10
2.2. Product Variants and Frequency Bands	10
2.3. Target Market	10
2.4. Main features	11
2.5. TX Output Power	11
2.5.1. NE310L2-W1	11
2.5.2. NE310L2-WW	11
2.6. RX Sensitivity	12
2.6.1. NE310L2-W1	12
2.6.2. NE310L2-WW	12
2.7. Mechanical Specifications	13
2.7.1. Dimensions	13
2.7.2. Weight	14
2.8. Temperature Range	14
3. PINS ALLOCATION	15
3.1. Pin-out	15
3.2. LGA Pads Layout	20
4. POWER SUPPLY	21



- 4.1. Power Supply Requirements..... 21
- 4.2. Power Consumption..... 22
 - 4.2.1. NE310L2-W1, NE310L2-WW Idle mode 22
 - 4.2.2. NE310L2-W1 Connected Mode..... 23
 - 4.2.3. NE310L2-WW Connected Mode..... 23
- 4.3. General Design Rules 24
 - 4.3.1. Electrical Design Guidelines 24
 - 4.3.1.1. +5V Source Power Supply Design Guidelines 24
 - 4.3.1.2. +12V Source Power Supply Design Guidelines 25
 - 4.3.1.3. Battery Source Power Supply Design Guidelines..... 26
 - 4.3.2. Thermal Design Guidelines 27
 - 4.3.3. Power Supply PCB layout Guidelines..... 27
- 4.4. RTC Supply 28
- 4.5. PWRMON Power-on monitor..... 28
- 5. DIGITAL SECTION 30**
 - 5.1. Logic Levels 30
 - 5.2. Power On 31
 - 5.3. Power Off..... 31
 - 5.4. Unconditional shutdown 31
 - 5.5. Wake up from deep sleep mode 31
 - 5.6. Fast shut down..... 31
 - 5.7. Communication ports 32
 - 5.7.1. SPI..... 32
 - 5.7.2. Serial Ports 32
 - 5.7.2.1. Asynchronous Serial Port (USIF0)..... 33
 - 5.7.2.2. Asynchronous Serial Port (USIF1)..... 34
 - 5.7.2.3. Auxiliary Serial Port..... 35
 - 5.8. General purpose I/O..... 35
 - 5.8.1. Using a GPIO as INPUT 36

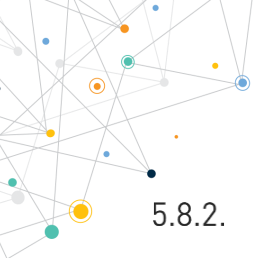

- 5.8.2. Using a GPIO as OUTPUT 36
- 5.9. External SIM Holder..... 36
- 5.10. ADC Converter 37
- 5.10.1. Using ADC Converter 37
- 5.11. DAC Converter 37
- 5.11.1. Enabling DAC 38
- 6. RF SECTION..... 39**
- 6.1. Antenna requirements..... 39
- 6.1.1. PCB Design guidelines 39
- 7. MECHANICAL DESIGN 41**
- 7.1. Drawing 41
- 7.1.1. NE310L2-W1 41
- 7.1.2. NE310L2-WW 41
- 8. APPLICATION PCB DESIGN 43**
- 8.1. Footprint..... 43
- 8.1.1. NE310L2-W1 43
- 8.1.2. NE310L2-WW 45
- 8.1.3. Recommendations for NE310L2-W1..... 47
- 8.1.4. Recommendations for NE310L2-WW 48
- 8.2. PCB pad design 49
- 8.3. Stencil..... 50
- 8.4. Solder paste 50
- 8.5. Solder Reflow..... 50
- 9. PACKAGING 52**
- 9.1. Tray..... 52
- 9.1.1. NE310L2-W1 52
- 9.1.2. NE310L2-WW 54
- 9.2. Reel..... 56

9.2.1.	NE310L2-W1	56
9.2.2.	NE310L2-WW	57
10.	CONFORMITY ASSESSMENT ISSUES	58
10.1.	Approvals summary.....	58
10.2.	RED approval.....	58
10.2.1.	RED Declaration of Conformity	58
10.2.2.	RED Antennas	58
10.3.	FCC and ISED approval / <i>FCC et ISDE approbation</i>	59
10.3.1.	FCC certificates.....	59
10.3.2.	ISED Certificate / <i>ISDE certificates</i>	59
10.3.3.	Applicable FCC and ISED rules / <i>Liste des règles FCC et ISDE applicables</i>	59
10.3.4.	FCC and ISED Regulatory notices / <i>Avis réglementaires de FCC et ISDE</i>	60
10.3.5.	FCC/ISED Antennas / <i>FCC/ISDE Antennes</i>	61
10.3.6.	FCC label and compliance information.....	63
10.3.7.	ISED label and compliance information / <i>Étiquette et informations de conformité ISDE</i>	63
10.3.8.	Information on test modes and additional testing requirements / <i>Informations sur les modes de test et les exigences de test supplémentaires</i>	64
10.3.9.	FCC Additional testing, Part 15 Subpart B disclaimer	65
11.	PRODUCT AND SAFETY INFORMATION	66
11.1.	Copyrights and Other Notices	66
11.1.1.	Copyrights	66
11.1.2.	Computer Software Copyrights	66
11.2.	Usage and Disclosure Restrictions	67
11.2.1.	License Agreements	67
11.2.2.	Copyrighted Materials	67
11.2.3.	High Risk Materials.....	67



11.2.4.	Trademarks.....	68
11.2.5.	3rd Party Rights	68
11.2.6.	Waiver of Liability.....	68
11.3.	Safety Recommendations.....	69
12.	GLOSSARY	70
13.	DOCUMENT HISTORY.....	72

1. INTRODUCTION

1.1. Scope

This document introduces the NE310L2 module and presents possible and recommended hardware solutions for the development of a product based on this module. All the features and the solutions described in this document are applicable to all the variants listed in the applicability table.

This document cannot include every hardware solution or every product that can be designed. Where the suggested hardware configurations are not to be considered mandatory, the information provided should be used as a guide and starting point for the proper development of the product with the Telit module.

1.2. Audience

This document is intended for Telit customers, in particular system integrators, who are going to implement their applications using our NE310L2 modules.

1.3. Contact Information, Support

For general contact, technical support services, technical questions and report of documentation errors contact Telit Technical Support at:

- TS-EMEA@telit.com
- TS-AMERICAS@telit.com
- TS-APAC@telit.com

Alternatively, use:

<http://www.telit.com/support>

For detailed information about where you can buy the Telit modules or for recommendations on accessories and components visit:

<http://www.telit.com>

Our aim is to make this guide as helpful as possible. Keep us informed with your comments and suggestions for improvements.

Telit appreciates the user feedback on our information.

1.4. Symbol Conventions



Danger: This information **MUST** be followed or catastrophic equipment failure or personal injury may occur.



Warning: Alerts the user on important steps about the module integration.



Note/Tip: Provides advice and suggestions that may be useful when integrating the module.



Electro-static Discharge: Notifies the user to take proper grounding precautions before handling the product.

Table 1: Symbol Conventions

All dates are in ISO 8601 format, that is YYYY-MM-DD.

1.5. Related documents

80668ST11067A NE310L2 AT Commands Reference Guide

2. GENERAL PRODUCT DESCRIPTION

2.1. Overview

The NE310L2 module is a NBIoT communication product that allows integrators to plan availability for even the longest lifecycle applications, highly recommended for new designs specified for worldwide coverage.

The NE310L2 operates with 1.8 V GPIOs, minimizing power consumption and making it even more ideal for application with battery-powered and wearable devices.

2.2. Product Variants and Frequency Bands

Product	2G Band (MHz)	LTE CATM1	NB IoT	CS Voice VoLTE	Region
NE310L2-W1	-	-	B1, B2, B3, B4, B5, B8, B12, B13, B18, B19, B20, B25, B26, B28, B66, B85	N	Worldwide
NE310L2-WW	850, 900, 1800, 1900	-	B1, B2, B3, B4, B5, B8, B12, B13, B18, B19, B20, B25, B26, B28, B66, B85	N	Worldwide

Table 2: Product Variants and their Frequency Bands

Refer to “RF Section” for details information about frequencies.



Note: Cellular technologies and frequency bands may vary based on firmware version and firmware configuration used.

2.3. Target Market

NE310L2 can be used for Global IoT applications such as smart metering, healthcare monitoring, home automation, industrial sensors, smart agriculture, asset tracking, point of sale, portable devices and many others benefitting from low-power and low-data rate capabilities.

2.4. Main features

Function	Features
Modem	<ul style="list-style-type: none"> • NBIoT technology • SMS support (text and PDU) • Real Time Clock
Interfaces	<ul style="list-style-type: none"> • USIF0 Main UART (AT command* and Log) • AUX UART (AT Command*, FW Upgrade, LOG) • SPI** • 6 GPIOs • Antenna port

Table 3: Functional Features

* Functionality depending on ports configuration

** Functionality not available on MKT samples

2.5. TX Output Power

2.5.1. NE310L2-W1

Band	Mode	Class	RF power (dBm) Nominal*
B1, B2, B3, B4, B5, B8, B12, B13, B18, B19, B20, B25, B26, B28, B66, B85	(LTE) CAT-NB1	3	23

Table 4: Transmission Output Power

* Max output power tolerance range according to 3GPP TS 36.521-1 or better

2.5.2. NE310L2-WW

Band	Mode	Class	RF power (dBm) Nominal*
850/900MHz	GPRS	4	32.5
1800/1900MHz	GPRS	1	29.5
B1, B2, B3, B4, B5, B8, B12, B13, B18, B19, B20, B25, B26, B28, B66, B85	(LTE) CAT-NB1	3	23

Table 5: Transmission Output Power

* Max output power tolerance range according to 3GPP TS 36.521-1 and 3GPP TS 51.010-1 or better

2.6. RX Sensitivity

2.6.1. NE310L2-W1

Band	REFsens (dBm) Typical	REFsens (dBm)* 3GPP Limit
CAT NB2 / Band1	-114.6	-108.2
CAT NB2 / Band2	-114.3	-108.2
CAT NB2 / Band3	-114.9	-108.2
CAT NB2 / Band4	-114.5	-108.2
CAT NB2 / Band5	-114.6	-108.2
CAT NB2 / Band8	-114.8	-108.2
CAT NB2 / Band12	-114.4	-108.2
CAT NB2 / Band13	-114.8	-108.2
CAT NB2 / Band18	-114.5	-108.2
CAT NB2 / Band19	-114.7	-108.2
CAT NB2 / Band20	-114.7	-108.2
CAT NB2 / Band25	-114.8	-108.2
CAT NB2 / Band26	-114.2	-108.2
CAT NB2 / Band28	-114.2	-108.2
CAT NB2 / Band66	-114.6	-108.2
CAT NB2 / Band85	-114.5	-108.2

Table 6: RX Sensitivity NE310L2-W1 * 3GPP TS 36.521-1 Release 15 Minimum performance requirement

2.6.2. NE310L2-WW

Band	REFsens (dBm) Typical	REFsens (dBm)* 3GPP Limit
CAT NB2 / Band1	TBD	-108.2
CAT NB2 / Band2	TBD	-108.2

Band	REFsens (dBm) Typical	REFsens (dBm)* 3GPP Limit
CAT NB2 / Band3	TBD	-108.2
CAT NB2 / Band4	TBD	-108.2
CAT NB2 / Band5	TBD	-108.2
CAT NB2 / Band8	TBD	-108.2
CAT NB2 / Band12	TBD	-108.2
CAT NB2 / Band13	TBD	-108.2
CAT NB2 / Band18	TBD	-108.2
CAT NB2 / Band19	TBD	-108.2
CAT NB2 / Band20	TBD	-108.2
CAT NB2 / Band25	TBD	-108.2
CAT NB2 / Band26	TBD	-108.2
CAT NB2 / Band28	TBD	-108.2
CAT NB2 / Band66	TBD	-108.2
CAT NB2 / Band85	TBD	-108.2
GPRS / GSM850	TBD	
GPRS / GSM900	TBD	
GPRS / DCS1800	TBD	
GPRS / PCS1900	TBD	

Table 7: RX Sensitivity NE310L2-WW * 3GPP TS 36.521-1 Release 15 and 51.010-1 Minimum performance requirement

2.7. Mechanical Specifications

2.7.1. Dimensions

The overall dimensions of NE310L2-W1 are:

- Length: 14.3 mm
- Width: 13.1 mm
- Thickness: 2.6 mm

The overall dimensions of NE310L2-WW:

- Length: 18.0 mm
- Width: 15.0 mm
- Thickness: 2.6 mm

2.7.2. Weight

The nominal weight of the NE310L2-W1 is 1gr.

The nominal weight of the NE310L2-WW is 1.5gr.

2.8. Temperature Range

Temperature range	Note	
Normal Operating Temperature Range	-30°C to +70°C	The module is fully functional and compliant according to regulatory standards.
Extended Operating Temperature Range	-40°C to +85°C	The module is fully functional (*)
Storage Temperature Range	-40°C to +105°C	The module is not powered and not connected to power supply

Table 8: Temperature Range



Note: (*) Functional: if applicable, the module is able to make and receive data calls, send and receive SMS and data traffic.

3. PINS ALLOCATION

3.1. Pin-out

Pin	Signal	I/O	Function	Type	Comment
Asynchronous Serial Port (USIF0) – Prog. / Data + HW Flow Control					
Y16	C103/TXD0	I	Serial data input (TXD) from DTE	CMOS 1.8V	Internal PU (TBD)
AA15	C104/RXD0	O	Serial data output (RXD) to DTE	CMOS 1.8V	
Y18	C105/RTS0	I	Input for Request to send signal (RTS) from DTE	CMOS 1.8V	Internal PU (TBD)
AA17	C106/CTS0	O	Output for Clear to send signal (CTS) to DTE	CMOS 1.8V	
Auxiliary Serial Port					
Y10	TX_AUX	O	Auxiliary UART (TX Data to DTE)	CMOS 1.8V	
AA9	RX_AUX	I	Auxiliary UART (RX Data to DTE)	CMOS 1.8V	Internal PU (TBD)
SIM card interface					
L1	SIM_CLK	O	External signal – Clock	CMOS 1.8V	
M2	SIM_RST	O	External signal – Reset	CMOS 1.8V	
N1	SIM_DAT	I/O	External signal – Data I/O	CMOS 1.8V	
P2	SIM_VCC	-	Power supply for the SIM	1.8V	Only 1.8V simcard are supported
-	SIMIN	I	Presence input	CMOS 1.8V	See par.5.8
SPI					
AA5	SPI_MOSI	I/O	SPI MOSI	CMOS 1.8V	
Y8	SPI_MISO	I/O	SPI MISO	CMOS 1.8V	
AA7	SPI_CLK	I/O	SPI Clock	CMOS 1.8V	
Y6	SPI_CS	I/O	SPI Chip Select	CMOS 1.8V	
DIGITAL IO					

Pin	Signal	I/O	Function	Type	Comment
V11	I01	I/O	Configurable GPIO01/	CMOS 1.8V	Internal PU
V13	I02	I/O	Configurable GPIO02/	CMOS 1.8V	Internal PU
D7	I03	I/O	Configurable GPIO03	CMOS 1.8V	Internal PD (TBD)
D9	I04	I/O	Configurable GPIO04	CMOS 1.8V	Internal PU (TBD)
D11	I05	I/O	Configurable GPIO05	CMOS 1.8V	Internal PU (TBD)
D13	I06	I/O	Configurable GPIO06	CMOS 1.8V	Internal PD (TBD)
ADC and DAC					
B18	ADC	I	Analog To Digital converter Input	A/D	
R16	DAC	O	Digital To Analog converter Output	D/A	PWM signal
RF Section					
A5	CELL_MAIN ANTENNA	I/O	Main Antenna (50 ohm)	RF	
Miscellaneous Functions					
B2	S_LED	O	Status LED	CMOS 1.8V	
N16	ON_OFF*/WAKE*	I	Input Command for Power ON/OFF and to wake from deep sleep mode	Internal Power Supply (MAX 1.6V low power mode)	Active Low, Internal PU (620K)
R19	HW_SHUTDOWN*	I	HW Unconditional Shutdown	Internal Power Supply (MAX 1.6V low power mode)	Active Low, Internal PU (620K)
1	PWRMON	O	Power ON Monitor	CMOS 1.8V	
Power Supply					

Pin	Signal	I/O	Function	Type	Comment
W1	VBATT_PA	-	Main power supply (Radio PA)	Power	
AA3	VBATT	-	Main power supply (Baseband)	Power	
N4	CTANK	-	Internal supply domain pin for external tank capacitor	1.8V	
A3	GND	-	RF Ground	Power	
A7	GND	-	RF Ground	Power	
A9	GND	-	RF Ground	Power	
A13	GND	-	RF Ground	Power	
A17	GND	-	RF Ground	Power	
B4	GND	-	RF Ground	Power	
B6	GND	-	RF Ground	Power	
B10	GND	-	RF Ground	Power	
B12	GND	-	RF Ground	Power	
B14	GND	-	RF Ground	Power	
B16	GND	-	RF Ground	Power	
C19	GND	-	RF Ground	Power	
D18	GND	-	RF Ground	Power	
F8	GND	-	Thermal Ground	Power	
F12	GND	-	Thermal Ground	Power	
F18	GND	-	Thermal Ground	Power	
G19	GND	-	Thermal Ground	Power	
H6	GND	-	Thermal Ground	Power	
H14	GND	-	Thermal Ground	Power	
J19	GND	-	Thermal Ground	Power	
K18	GND	-	Thermal Ground	Power	
M18	GND	-	Thermal Ground	Power	
N19	GND	-	Thermal Ground	Power	
P6	GND	-	Thermal Ground	Power	
P14	GND	-	Thermal Ground	Power	
T8	GND	-	Thermal Ground	Power	

Pin	Signal	I/O	Function	Type	Comment
T12	GND	-	Thermal Ground	Power	
U1	GND	-	Power Ground	Power	
V2	GND	-	Power Ground	Power	
W19	GND	-	Power Ground	Power	
Y2	GND	-	Power Ground	Power	
Y4	GND	-	Power Ground	Power	
RESERVED					
G1	RESERVED	-	RESERVED		
H2	RESERVED	-	RESERVED		
J1	RESERVED	-	RESERVED		
K2	RESERVED	-	RESERVED		
J4	RESERVED	-	RESERVED		
G4	RESERVED	-	RESERVED		
L19	RESERVED	-	RESERVED		
A11	RESERVED	-	RESERVED		
R4	RESERVED	-	RESERVED		
L4	RESERVED	-	RESERVED		
V7	RESERVED	-	RESERVED		
V9	RESERVED	-	RESERVED		
L16	RESERVED	-	RESERVED		
P18	RESERVED	-	RESERVED		
J16	RESERVED	-	RESERVED		
B8	RESERVED	-	RESERVED		
A15	RESERVED	-	RESERVED		
U19	RESERVED	-	RESERVED		
V18	RESERVED	-	RESERVED		
T18	RESERVED	-	RESERVED		
Y12	RESERVED	-	RESERVED		
AA11	RESERVED	-	RESERVED		
AA13	RESERVED	-	RESERVED		
Y14	RESERVED	-	RESERVED		

Pin	Signal	I/O	Function	Type	Comment
E19	RESERVED	-	RESERVED		
H18	RESERVED	-	RESERVED		
G16	RESERVED	-	RESERVED		
T2	RESERVED	-	RESERVED		
C1	RESERVED	-	RESERVED		
D2	RESERVED	-	RESERVED		
E1	RESERVED	-	RESERVED		
F2	RESERVED	-	RESERVED		

Table 9: Pin-out Information



Warning: Reserved pins must not be connected.



Warning: C104/RXD1 cannot have any PU or HIGH state during BOOTING UP phase.

3.2. LGA Pads Layout

TOP VIEW

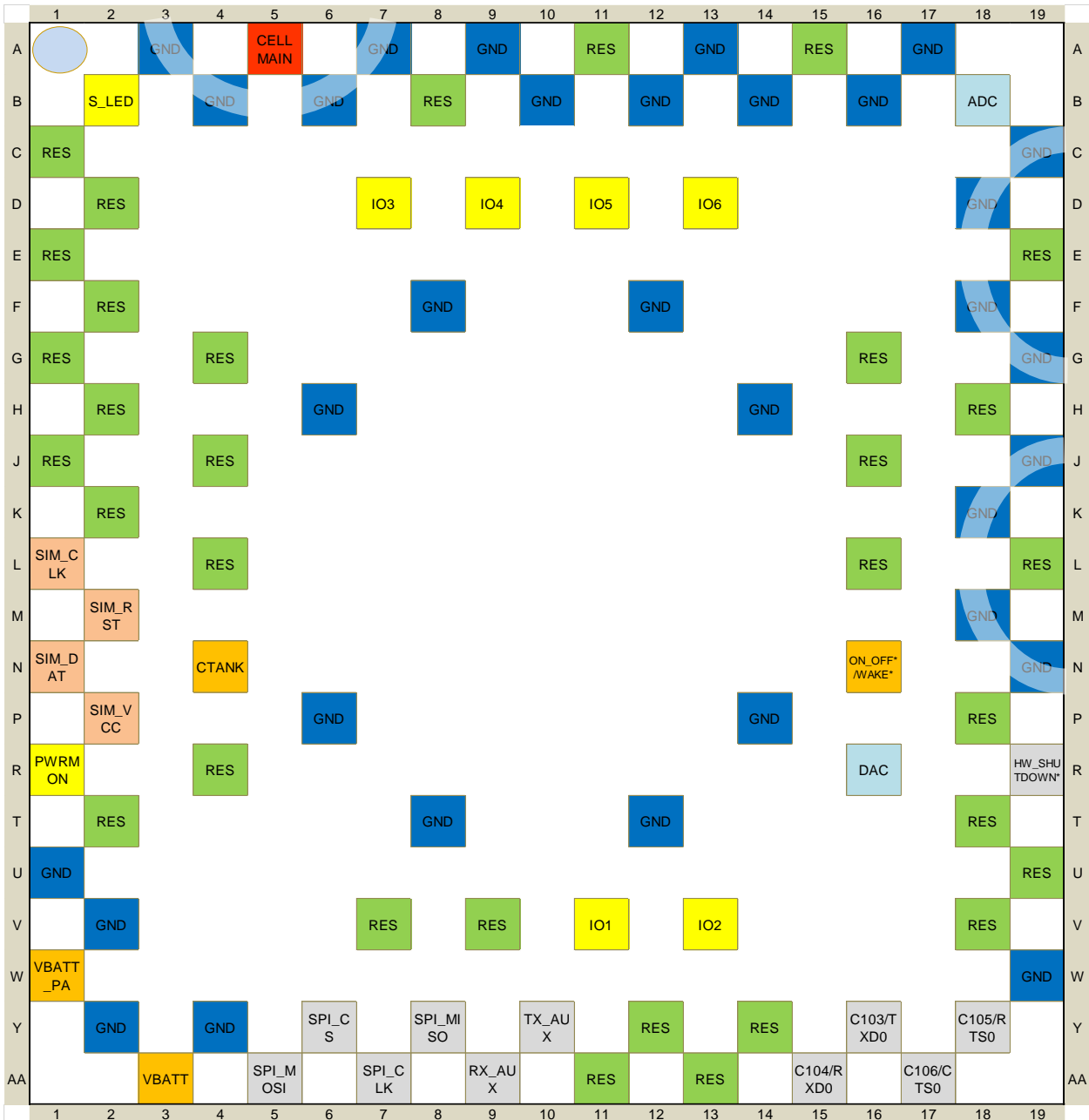

Figure 1: LGA Pads Layout

	SUPPLY AND CONTROL
	SIM CARD
	ANALOG FUNCTIONALITY
	GROUND
	DIGITAL FUNCTIONALITY
	DIGITAL COMMUNICATION
	RF SIGNALS
	RESERVED/NOT ASSIGNED/ RESERVED FOR FUTURE USE
	GNSS

4. POWER SUPPLY

The power supply circuitry and the board layout are a very important part in the full product design and they strongly reflect on the overall performance of the product so the requirements and the guidelines that will follow should be read carefully for a proper design.

4.1. Power Supply Requirements

The external power supply must be connected to VBATT & VBATT_PA signals and must fulfil the following requirements:

Power Supply	Value
Nominal Supply Voltage	3.8V
Operating Voltage Range	3.2 V - 4.2 V
Extended Voltage Range	2.1 V - 4.5 V
VBATTmin	2.2V

Table 10: Power Supply Requirements



Warning: The supply voltage of the modem must never exceed the Extended Operating Voltage Range.

Wrong implementation of power supply guidelines described in this document may result in module fault.



Note: For PTCRB approval on the final products the power supply is required to be within the “Normal Operating Voltage Range”.

Note: The application's power supply section must be designed with care to avoid an excessive voltage drop during transmission peak current absorptions. If the voltage drops beyond the limits of the Extended Operating Voltage range, an unintentional module power off can occur.



Note: When turning on the modem, the voltage must be at least VBATTmin.

Note: HW User Guide specifications shall be fully acknowledged and correctly implemented in order to use the module in its "Extended Operating Voltage Range".

4.2. Power Consumption

4.2.1. NE310L2-W1, NE310L2-WW Idle mode

Mode		Mode Description		
		NB-IoT (mA)	2G (mA)	
IDLE mode				
AT+CFUN=1		TBD	-	Normal mode: full functionality of the module
AT+CFUN=4				Disabled TX and RX; module is not registered on the network
AT+CFUN=5		TBD	-	Paging cycle #256 frames (2.56s DRx cycle)
		TBD	-	81.92s eDRx cycle length (PTW=2.56s, DRX=1.28s)
		TBD	-	327.68s eDRx cycle length (PTW=2.56s, DRX=1.28s)
		TBD	-	655.36s eDRx cycle length (PTW=2.56s, DRX=1.28s)
		TBD	-	1310.72s eDRx cycle length (PTW=2.56s, DRX=1.28s)
		TBD	-	2621.44s eDRx cycle length (PTW=2.56s, DRX=1.28s)
		-	-	Paging Multiframe 9
PSM mode				
AT+CPSMS=1				No current source or sink by any connected pin

Table 11: Idle and PSM mode



Note: The reported LTE CAT NB1 idle mode values are an average among all the product variants and bands for each network wireless technology.

The support for a specific network wireless technology depends on the product variant configuration.

4.2.2. NE310L2-W1 Connected Mode

Mode	Measure (Typical)		Mode Description
	Average (mA)	Peak (mA)	
NBloT	245	340	3.75KHz subcarrier spacing, 1 SC, RU 32ms, TBS=0, BPSK, 23dBm, all bands
	65	290	15KHz subcarrier spacing, 12 SC, RU 1ms, TBS=5, QPSK, 21dBm, all bands

Table 12: NE310L2-W1 connected mode

4.2.3. NE310L2-WW Connected Mode

Mode	Measure (Typical)		Mode Description
	Average (mA)	Peak (mA)	
NBloT	245	340	3.75KHz subcarrier spacing, 1 SC, RU 32ms, TBS=0, BPSK, 23dBm, all bands
	65	290	15KHz subcarrier spacing, 12 SC, RU 1ms, TBS=5, QPSK, 21dBm, all bands
GPRS	TBD	TBD	1TX + 1RX, CS1, GMSK, Band 850, 900
	TBD	TBD	1TX + 1RX, CS1, GMSK, Band 1800, 1900

Table 13: NE310L2-WW connected mode

4.3. General Design Rules

The main guidelines for the Power Supply Design include three different design steps:

- the electrical design
- the thermal design
- the PCB layout

4.3.1. Electrical Design Guidelines

The electrical design of the power supply strongly depends on the power source where this power is drained. We will distinguish them into three categories:

- +5V input (typically PC internal regulator output)
- +12V input (typically automotive)
- Battery

4.3.1.1. +5V Source Power Supply Design Guidelines

- The desired output for the power supply is 3.8V, so there's not a big difference between the input source and the desired output and a linear regulator can be used. A switching power supply will not be suited due to the low drop out requirements.
- When using a linear regulator, a proper heat sink shall be provided in order to dissipate the power generated.
- A Bypass low ESR capacitor of adequate capacity must be provided in order to cut the current absorption peaks close to the Module, a 100 μ F capacitor is usually suitable.
- Make sure the low ESR capacitor on the power supply output is rated at least 10V.

An example of linear regulator with 5V input is:

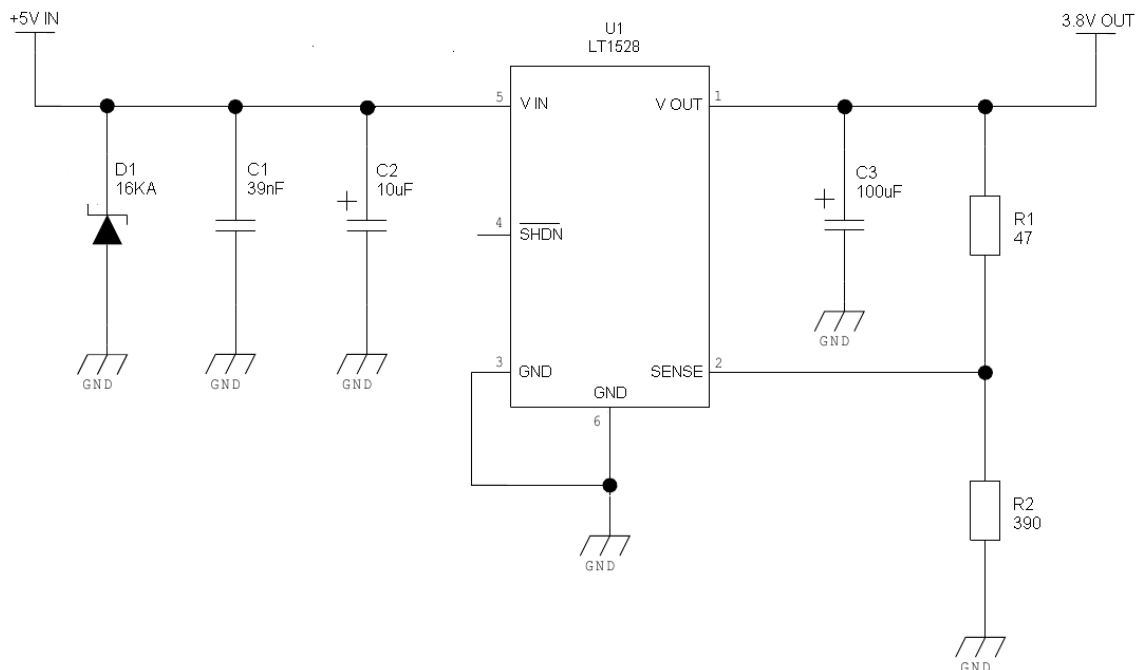

Figure 2: example of linear regulator with 5V input

4.3.1.2. +12V Source Power Supply Design Guidelines

- The desired output for the power supply is 3.8V, so due to the big difference between the input source and the desired output, a linear regulator is not suited and shall not be used. A switching power supply will be preferable because of its better efficiency.
- When using a switching regulator, a 500kHz or higher switching frequency regulator is preferable due to its smaller inductor size and its faster transient response. This allows the regulator to respond quickly to the current peaks absorption.
- In any case the frequency and Switching design selection is related to the application to be developed since the switching frequency could also generate EMC interferences.
- For car PB battery the input voltage can rise up to 15,8V and this should be kept in mind when choosing components: all components in the power supply must withstand this voltage.
- A Bypass low ESR capacitor of adequate capacity must be provided in order to cut the current absorption peaks, a 100 μ F capacitor is usually suitable.
- Make sure the low ESR capacitor on the power supply output has a nominal voltage of at least 10V.

- For Car applications a spike protection diode should be inserted close to the power input, in order to clean the power supply from the spikes.

An example of switching regulator with 12V input is in the below schematic:

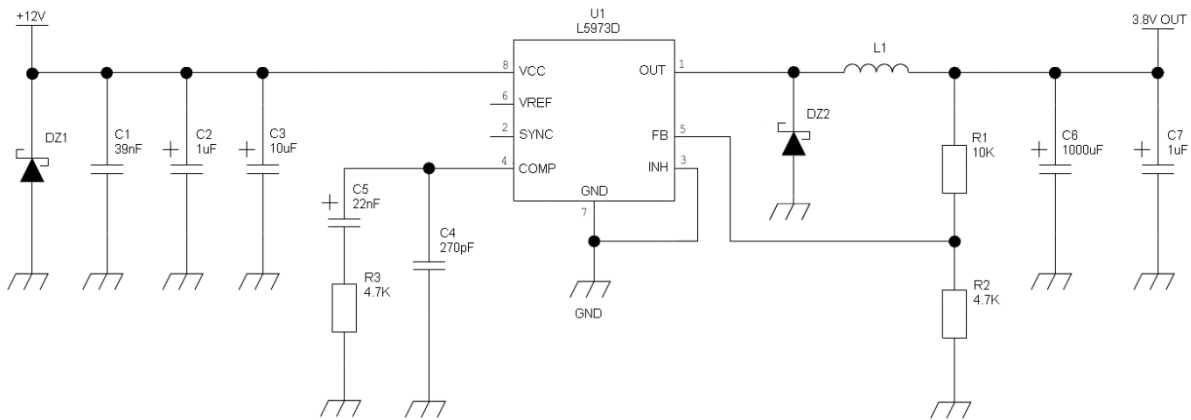

Figure 3: Recommended Circuit

4.3.1.3. Battery Source Power Supply Design Guidelines

The desired nominal output for the power supply is 3.8V and the maximum voltage allowed is 4.2V, hence a single 3.7V Li-Ion cell battery type is suited for supplying the power to the Telit NE310L2 module.

- A Bypass low ESR capacitor of adequate capacity must be provided in order to cut the current absorption peaks, a 100 μ F tantalum capacitor is usually suited.
- Make sure the low ESR capacitor (usually a tantalum one) is rated of at least 10V.
- A protection diode should be inserted close to the power input, in order to save the NE310L2 from power polarity inversion. Otherwise the battery connector should be done in a way to avoid polarity inversions when connecting the battery.
- The battery must be rated to supply current peaks up to TBD A.



Note: DO NOT USE any type of Ni-Cd, Ni-MH, and Pb battery directly connected to NE310L2. Their use can lead to overvoltage on the NE310L2 and damage it. USE ONLY Li-Ion battery types.

4.3.2. Thermal Design Guidelines

Worst case as reference values for thermal design of NE310L2 are:

- Average current consumption: TBD mA (LTE CAT NB1)
- Supply voltage: 4.50V



Note: Make PCB design in order to have the best connection of GND pads to large surfaces of copper.



Note: The NE310L2 includes a function to prevent overheating.

4.3.3. Power Supply PCB layout Guidelines

As seen in the guidelines for electrical design, the power supply shall have a low ESR capacitor on the output to cut the current peaks on the input to protect the supply from spikes. The placement of this component is crucial for the correct working of the circuitry. A misplaced component can be useless or can even decrease the power supply performance.

- The Bypass low ESR capacitor must be placed close to the Telit NE310L2 power input pads or, if the power supply is a switching type, it can be placed close to the inductor to cut the ripple, provided the PCB trace from the capacitor to the NE310L2 is wide enough to ensure a dropleless connection even during an TBD current peak.
- The protection diode must be placed close to the input connector where the power source is drained.
- The PCB's traces to the NE310L2 and the Bypass capacitor must be wide enough to ensure that no significant voltage drops occur. This is for the same reason as previous point. Try to keep this trace as short as possible.
- To reduce the EMI due to switching, it is important to keep the mesh involved very small; therefore the input capacitor, the output diode (if not incorporated in the IC) and the regulator shall form a very small loop. This is done in order to reduce the radiated field (noise) to the switching frequency (100-500 kHz usually).
- A dedicated ground for the Switching regulator separated by the common ground plane is suggested.

- The placement of the power supply on the board should be done in such a way to guarantee that the high current return paths in the ground plane are not overlapped to any noise sensitive circuitry as the microphone amplifier/buffer or earphone amplifier.
- The power supply input cables should be kept separate from noise sensitive lines such as microphone/earphone cables.
- The insertion of the EMI filter on the VBATT pins is suggested in those designs where the antenna is placed close to battery or power supply lines. A ferrite bead like Murata BLM18EG101TN1 or Taiyo Yuden P/N FBMH1608HM101 can be used for this purpose.

The below figure shows the recommended circuit:

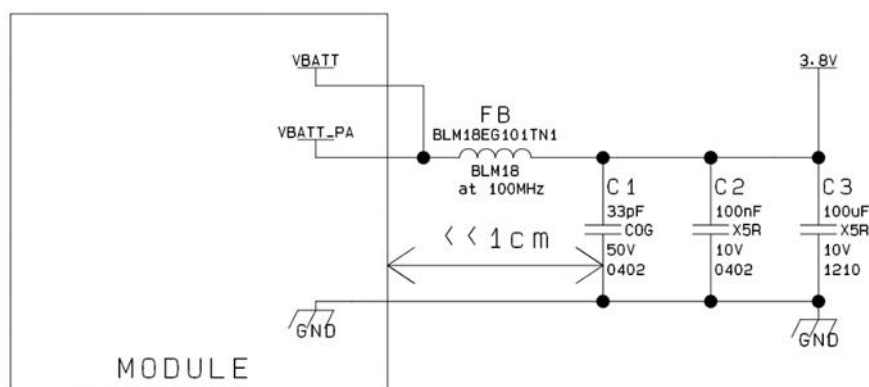

Figure 4: recommended circuit

4.4. RTC Supply

RTC is functional when NE310L2 is in PSM or OFF state and VBATT pin is supplied.

RTC settings are lost when VBATT supply is removed.

4.5. PWRMON Power-on monitor

PWRMON is always active (output high) when the module is powered ON (module powered ON indication) and cannot be set to LOW level by any AT command.

This signal is present on pin R1. The operating range characteristics of PWRMON signal are:

Item	Min	Typical	Max
Output voltage	1.35V	1.8V	1.8V

Output current	-	1mA	3mA
----------------	---	-----	-----

Table 14: Operating range characteristics of PWRMON signal



Note: PWRMON during PSM period is LOW (PSM has to be previously enabled by AT+CPSMS command)



Note: The Output Current MUST never be exceeded; care must be taken when designing the application section to avoid an excessive current consumption. If the Current exceeds the limits it may cause a module shutdown.



Warning: This signal is NOT provided in order to supply small devices from the module.

PWRMON is only a module power-on indicator.

5. DIGITAL SECTION

NE310L2 has four main operation states:

- **OFF state:** Vbatt is applied and only RTC is running. The Baseband is switched OFF and the only possible change is the ON state.
- **ON state:** the baseband is fully switched on and NE310L2 is ready to accept AT commands. NE310L2 can be idle or connected.
- **Sleep mode state:** the main baseband processor is intermittently switched ON and AT commands can be processed with some latency. NE310L2 is idle with low current consumption.
- **Deep sleep mode state:** PSM defined in 3GPP Release 12. Baseband is switched OFF most of the time.

5.1. Logic Levels

Parameter	Min	Max
ABSOLUTE MAXIMUM RATINGS – NOT FUNCTIONAL		
Input level on any digital pin (CMOS 1.8) with respect to ground	TBD	TBD
Operating Range - Interface levels (1.8V CMOS)		
Input high level	TBD	TBD
Input low level	TBD	TBD
Output high level	TBD	TBD
Output low level	TBD	TBD

Table 15: Logic levels Minimum and maximum

Parameter	Max
Current characteristics:	
Output Current	1mA
Input Current	1uA

Table 16: Logic levels average

5.2. Power On

Available in a next document revision.

5.3. Power Off

Available in a next document revision.

5.4. Unconditional shutdown

Available in a next document revision.

5.5. Wake up from deep sleep mode

Available in a next document revision.

5.6. Fast shut down

Available in a next document revision.

5.7. Communication ports

5.7.1. SPI

The NE310L2 Module is provided by a standard 3-wire SPI master or slave interface with chip select control.

The following table is listing the available signals:

PAD	Signal	I/O	Function	Type	NOTE
AA5	SPI_MOSI	I/O	SPI MOSI	CMOS 1.8V	
Y8	SPI_MISO	I/O	SPI MISO	CMOS 1.8V	
AA7	SPI_CLK	I/O	SPI Clock	CMOS 1.8V	
Y6	SPI_CS	I/O	SPI Chip Select	CMOS 1.8V	

Table 17: Available signals



Note: The SPI interface is supported through the Telit AppZone APIs.

5.7.2. Serial Ports

The NE310L2 module is provided by 3 Asynchronous serial ports:

- Asynchronous Serial Port (USIF0)
- Asynchronous Serial Port (USIF1)*
- Auxiliary Serial Port

Several configurations can be designed for the serial port on the OEM hardware, but the most common are:

- RS232 PC com port
- microcontroller UART @ 1.8V (Universal Asynchronous Receive Transmit)
- microcontroller UART @ 5V or other voltages different from 1.8V

Depending on the type of serial port on the OEM hardware, a level translator circuit may be needed to make the system work. On the NE310L2 the ports are CMOS 1.8.



Note:*The USIF1 is currently NOT supported by NE310L2 firmware.

5.7.2.1. Asynchronous Serial Port (USIF0)

The serial port 0 on the NE310L2 is a +1.8V UART with 5 RS232 signals. It differs from the PC-RS232 in the signal polarity (RS232 is reversed) and levels.

The following table is listing the available signals:

RS232 Pin	Signal	Pad	Name	Usage
2	C104/RXD0	AA15	Transmit line	Output transmit line of NE310L2 UART
3	C103/TXD0	Y16	Receive line	Input receive of the NE310L2 UART Pull-up default during ON state
4	DTR	(*)	Data Terminal Ready	Input to the NE310L2 that controls the DTE READY condition
5	GND	A3, A7, A9, A13, A17, B4, B6, B10, B12, B14, B16, C19, D18, F8, F12, F18, G19, H6, H14, J19, K18, M18, N19, P6, P14, T8, T12, U1, V2, W19, Y2, Y4	Ground	Ground
8	C106/CTS0	AA17	Clear to Send	Output from the NE310L2 that controls the Hardware flow control
7	C105/RTS0	Y18	Request to Send	Input to the NE310L2 that controls the Hardware flow control Pull-up default during ON state
9	RING	(*)	Ring Indicator	Output from the NE310L2 that indicates the incoming call condition

Table 18: Available signs

* Alternate function with GPIO, refer to par. General Purpose I/O

Note: According to V.24, some signal names are referred to the application side, therefore on the NE310L2 side these signal are in the opposite direction:

TXD on the application side will be connected to the receive line (here named C103/TXD0)

RXD on the application side will be connected to the transmit line (here named C104/RXD0)



For a reduced implementation, only the TXD, RXD lines can be connected, the other lines can be left open provided that a software flow control is implemented.

In order to avoid a back powering it is recommended to avoid having any HIGH logic level signal applied to the digital pins of the NE310L2 when the module is powered off or during an ON/OFF transition (RESET included).

5.7.2.2. Asynchronous Serial Port (USIF1)

The serial port 1 on the NE310L2 is a +1.8V UART with 5 RS232 signals. It differs from the PC-RS232 in the signal polarity (RS232 is reversed) and levels.



Warning: C104/RXD1 cannot have any PU or HIGH state during BOOTING UP phase.

The following table lists the available signals:

RS232 Pin	Signal	Pad	Name	Usage
2	C104/RXD1	AA11	Transmit line	Output transmit line of NE310L2 UART
3	C103/TXD1	Y12	Receive line	Input receive of the NE310L2 UART Pull-up default during ON state
5	GND	A3, A7, A9, A13, A17, B4, B6, B10, B12, B14, B16, C19, D18, F8, F12, F18, G19, H6, H14, J19, K18, M18, N19, P6, P14, T8, T12, U1, V2, W19, Y2, Y4	Ground	Ground

RS232 Pin	Signal	Pad	Name	Usage
8	C106/CTS1	Y14	Clear to Send	Output from the NE310L2 that controls the Hardware flow control
7	C105/RTS1	AA13	Request to Send	Input to the NE310L2 that controls the Hardware flow control Pull-up default during ON state

Table 19: NE310L2 port signals

5.7.2.3. Auxiliary Serial Port

The auxiliary serial port on the NE310L2 is a CMOS 1.8V with only the RX and TX signals.

The signals of the NE310L2 serial port are:

PAD	Signal	I/O	Function	Type	NOTE
Y10	TX_AUX	O	Auxiliary UART (TX Data to DTE)	CMOS 1.8V	
AA9	RX_AUX	I	Auxiliary UART (RX Data from DTE)	CMOS 1.8V	

Table 20: NE310L2 serial port signals

5.8. General purpose I/O

The NE310L2 module is provided by a set of Configurable Digital Input / Output pins (CMOS 1.8V). Input pads can only be read; they report the digital value (high or low) present on the pad at the read time of. The Output pads can only be written or queried and set the value of the pad output.

An alternate function pad is internally controlled by the NE310L2 firmware and acts depending on the implemented function.

The following table shows the available GPIO on the NE310L2:

PAD	Signal	I/O	Drive Strength	Default State	NOTE
V11	GPIO_01	I/O	1 mA	INPUT - PD	Alternate function DTR
V13	GPIO_02	I/O	1 mA	INPUT - PD	Alternate function RING
D7	GPIO_03	I/O	1 mA	INPUT - PD	
D9	GPIO_04	I/O	1 mA	INPUT - PD	
D11	GPIO_05	I/O	1 mA	INPUT - PD	
D13	GPIO_06	I/O	1 mA	INPUT - PD	

Table 21: NE310L2 available GPIO

5.8.1. Using a GPIO as INPUT

The GPIO pads, when used as inputs, can be connected to another device's digital output and report its status, provided that this device has interface levels compatible with the 1.8V CMOS levels of the GPIO.



Note: In order to avoid a back powering, it is recommended to avoid having any HIGH logic level signal applied to the digital pins of the NE310L2 when the module is powered off or during an ON/OFF transition.

5.8.2. Using a GPIO as OUTPUT

The GPIO pads, when used as outputs, can drive 1.8V CMOS digital devices or compatible hardware. When set as outputs, the pads have a push-pull output and therefore the pull-up resistor may be omitted.

5.9. External SIM Holder

Please refer to the related User Guide (SIM Holder Design Guides, 80000NT10001a).



Note: There is no dedicated signal (SIMIN) for "Presence SIM" in the NE310L2 pinout.

This feature can be performed by connecting GPIO_01 (Pad **V11**) or of GPIO_02 (Pad **V13**) or of GPIO_03 (Pad **D7**) or of GPIO_04 (Pad **D9**) to the switch embedded in the sim-holder.

SIM detection can be configured by a specific AT Command.

Refer to the SW User Guide or the AT Commands Reference Guide for the full description of this function.

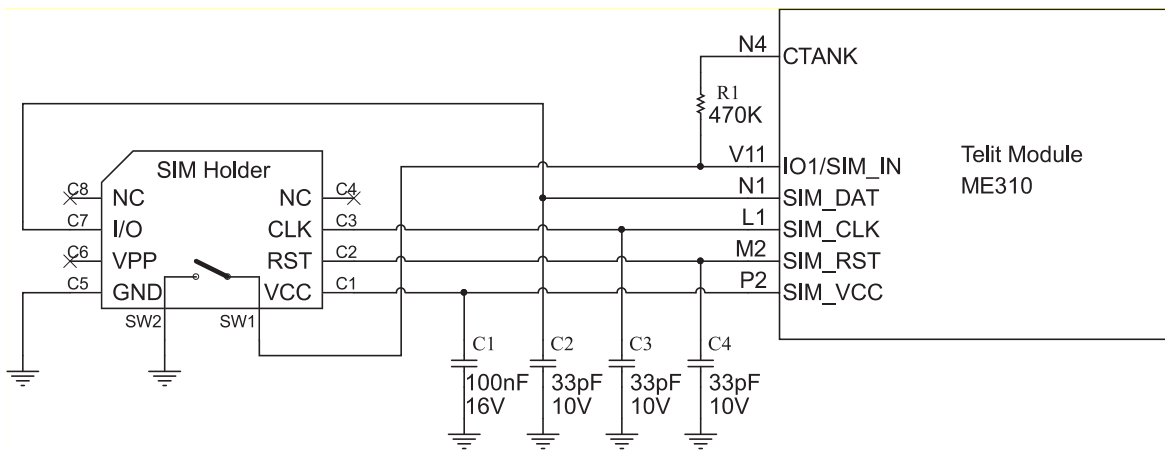

Figure 5: SIM Holder schematic



Warning: Pull-up 470K is required across CTANK (ball N4) and switch embedded in the sim-holder.

5.10. ADC Converter

The NE310L2 is provided by one AD converter. It is able to read a voltage level in the range of 0÷1.8 volts applied on the ADC pin input, store and convert it into 10 bit word.

The input lines are named as **ADC** (available on Pad **B18**).

The following table is showing the ADC characteristics:

Item	Min	Typical	Max	Unit
Input Voltage range	0	-	1.8	Volt
AD conversion	-	-	10	bits

Table 22 ADC Characteristics

5.10.1. Using ADC Converter

Available in a next document revision.

5.11. DAC Converter

The NE310L2 provides a Digital to Analog Converter. The signal (named DAC) is available on pin **R16** of the NE310L2.



5.11.1. Enabling DAC

Available in a next document revision.

6. RF SECTION

6.1. Antenna requirements

The antenna connection and board layout design are the most important aspect in the full product design as they strongly affect the general performance of the product, so read carefully and follow the requirements and the guidelines for a proper design.

The antenna and antenna transmission line on PCB for a Telit NE310L2 device shall fulfil the following requirements:

Item	Value
Frequency range	Depending by frequency band(s) provided by the network operator, the customer shall use the most suitable antenna for that/those band(s)
Bandwidth	250 MHz in LTE Band 1 140 MHz in LTE Band 2 and PCS1900 170 MHz in LTE Band 3 and DCS1800 445 MHz in LTE Band 4 70 MHz in LTE Band 5 and GSM850 80 MHz in LTE Band 8 and GSM900 47 MHz in LTE Band 12 41 MHz in LTE Band 13 60 MHz in LTE Band 18 60 MHz in LTE Band 19 71 MHz in LTE Band 20 145 MHz in LTE Band 25 80 MHz in LTE Band 26 100 MHz in LTE Band 28 490 MHz in LTE Band 66 48 MHz in LTE Band 85
Impedance	50 ohm
Input power	NE310L2-W1: > 24dBm Average power NE310L2-WW: > 35dBm Peak power
VSWR absolute max	≤ 10:1 (limit to avoid permanent damage)
VSWR recommended	≤ 2:1 (limit to fulfill all regulatory requirements)

Table 23: NE310L2 Antenna and Antenna transmission line on PCB

6.1.1. PCB Design guidelines

When using the NE310L2, since there's no antenna connector on the module, the antenna must be connected to the NE310L2 antenna pad by means of a transmission line implemented on the PCB. This transmission line shall fulfil the following requirements:

Item	Value
Characteristic Impedance	50 ohm (+-10%)

Max Attenuation	0.3 dB
Coupling	Coupling with other signals shall be avoided
Ground Plane	Cold End (Ground Plane) of antenna shall be equipotential to the NE310L2 ground pins

Table 24: NE310L2 Antenna pad requirements

The transmission line should be designed according to the following guidelines:

- make sure that the transmission line's characteristic impedance is 50ohm;
- keep line on the PCB as short as possible, since the antenna line loss shall be less than about 0.3 dB;
- line geometry should have uniform characteristics, constant cross section, avoid meanders and abrupt curves;
- any kind of suitable geometry / structure (Microstrip, Stripline, Coplanar, Grounded Coplanar Waveguide...) can be used to implement the printed transmission line afferent the antenna;
- if a Ground plane is required in line geometry, that plane shall be continuous and sufficiently extended, so that the geometry can be as similar as possible to the related canonical model;
- keep, if possible, at least one layer of the PCB used only for the Ground plane; If possible, use this layer as reference Ground plane for the transmission line;
- it is advisable to surround (on both sides) the PCB transmission line with Ground, avoiding that other signal tracks face directly the antenna line track;
- avoid crossing any un-shielded transmission line footprint with other signal tracks on different layers;
- the ground surrounding the antenna line on PCB shall be strictly connected to the main Ground Plane by means of via holes (at least once per 2mm), placed close to the ground edges facing the line track;
- place the noisy EM devices as far as possible from NE310L2 antenna line;
- keep the antenna line far away from the NE310L2 power supply lines;
- if EM noisy devices (such as fast switching ICs, LCD and so on) are present on the PCB hosting the NE310L2, take care of the shielding of the antenna line by burying it in an inner layer of PCB and surrounding it with the Ground planes, or shield it with a metal frame cover;
- if the noisy EM devices are not present around the line, the use of geometries such as Microstrip or Grounded Coplanar Waveguide is preferable, since they typically ensure less attenuation than a Stripline of the same length.

7. MECHANICAL DESIGN

7.1. Drawing

7.1.1. NE310L2-W1

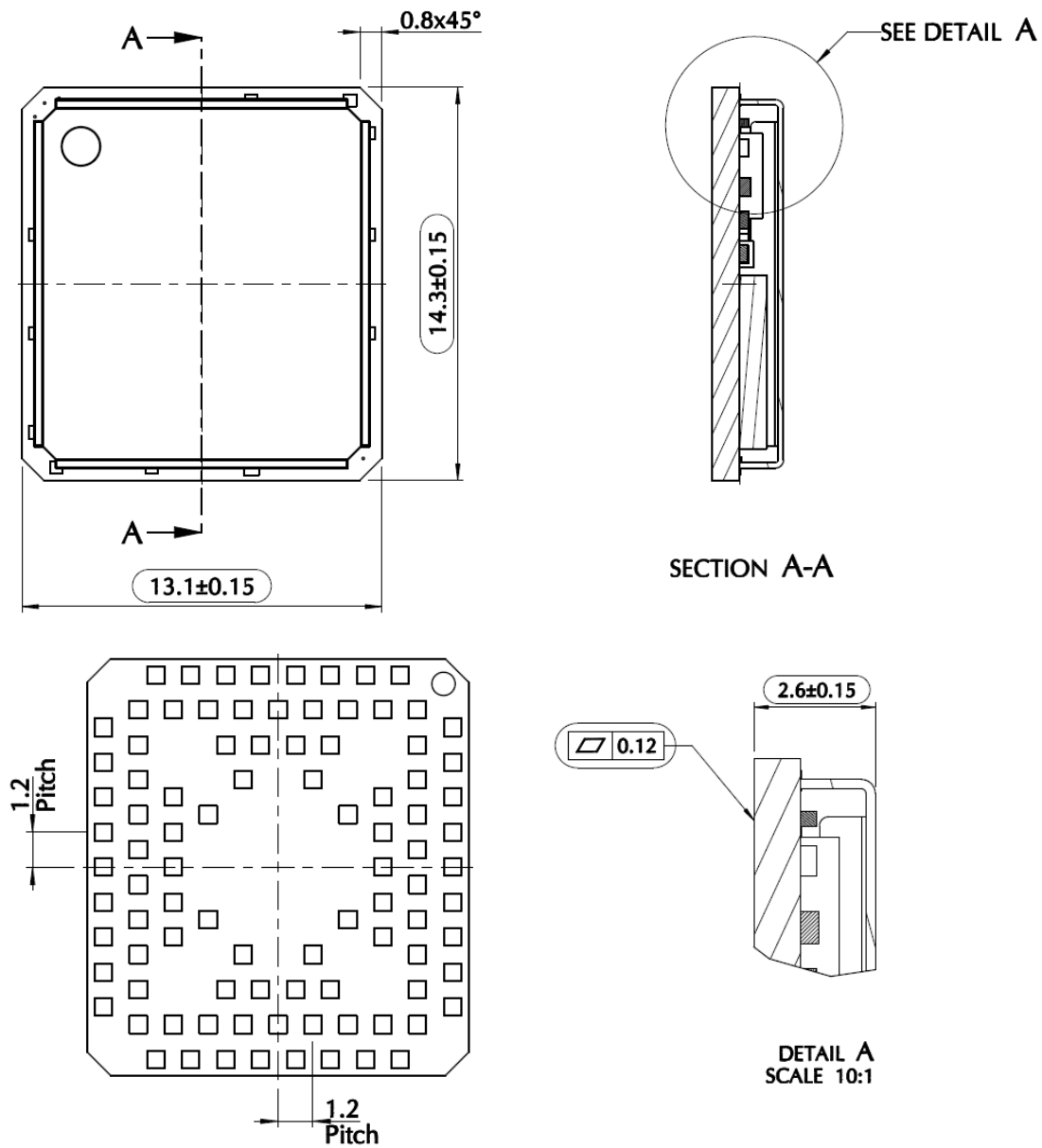

Figure 6: Mechanical Drawing NE310L2-W1

7.1.2. NE310L2-WW

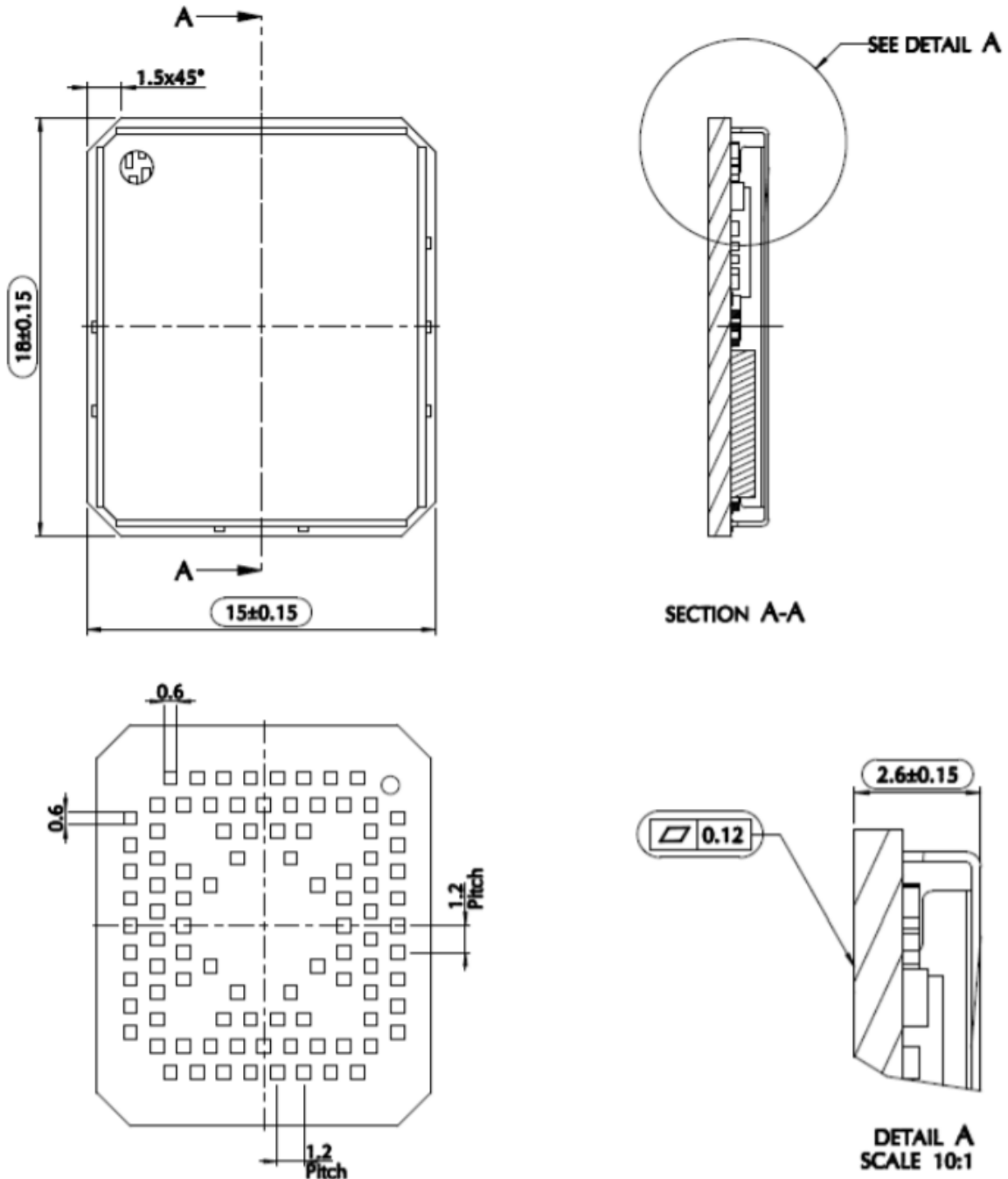

Figure 7: Mechanical Drawing NE310L2-WW



Note: Dimensions in mm. General Tolerance ± 0.1 , Angular Tolerance $\pm 1^\circ$, The tolerance is not cumulative.

SOLDER RESIST PATTERN (top view)

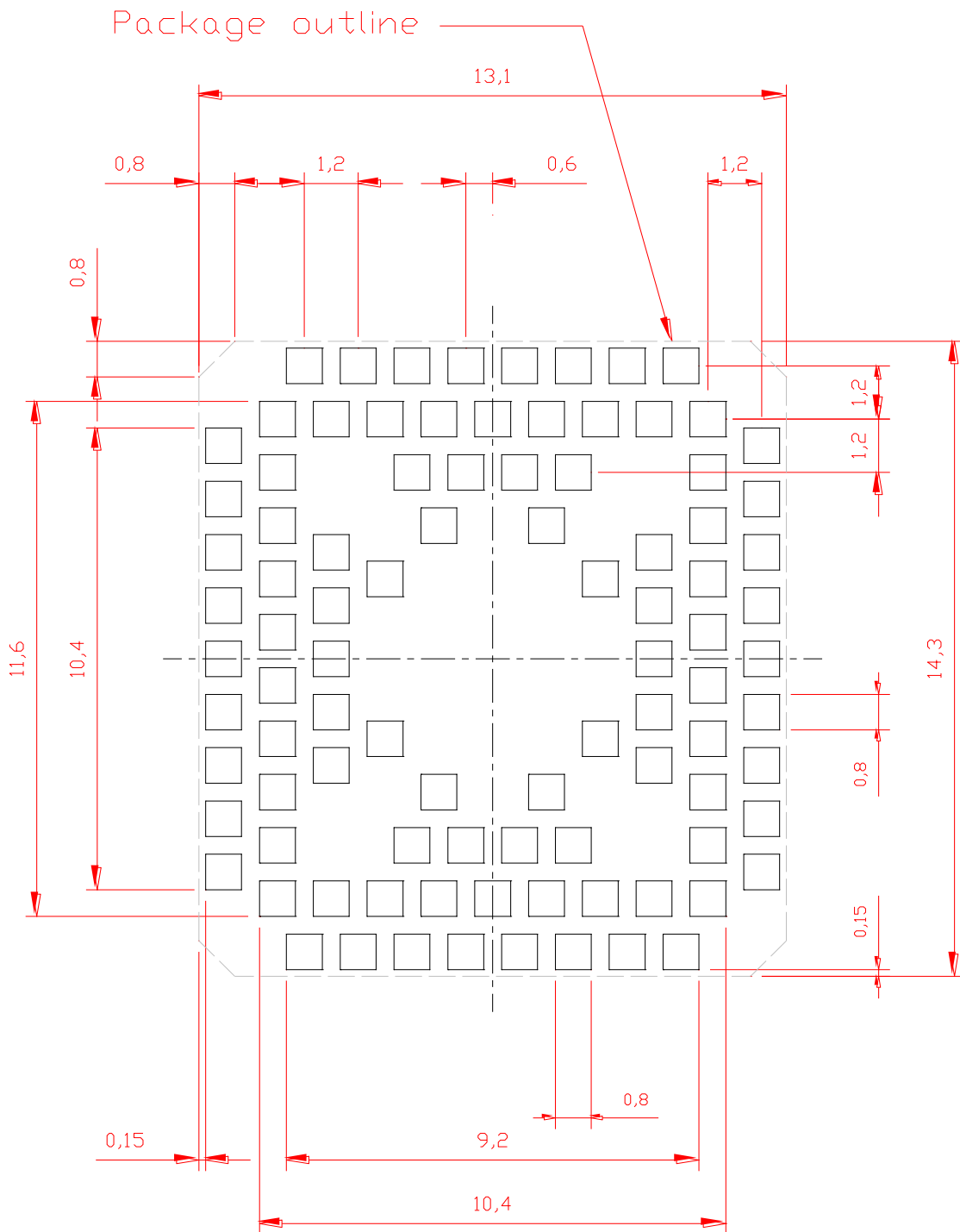
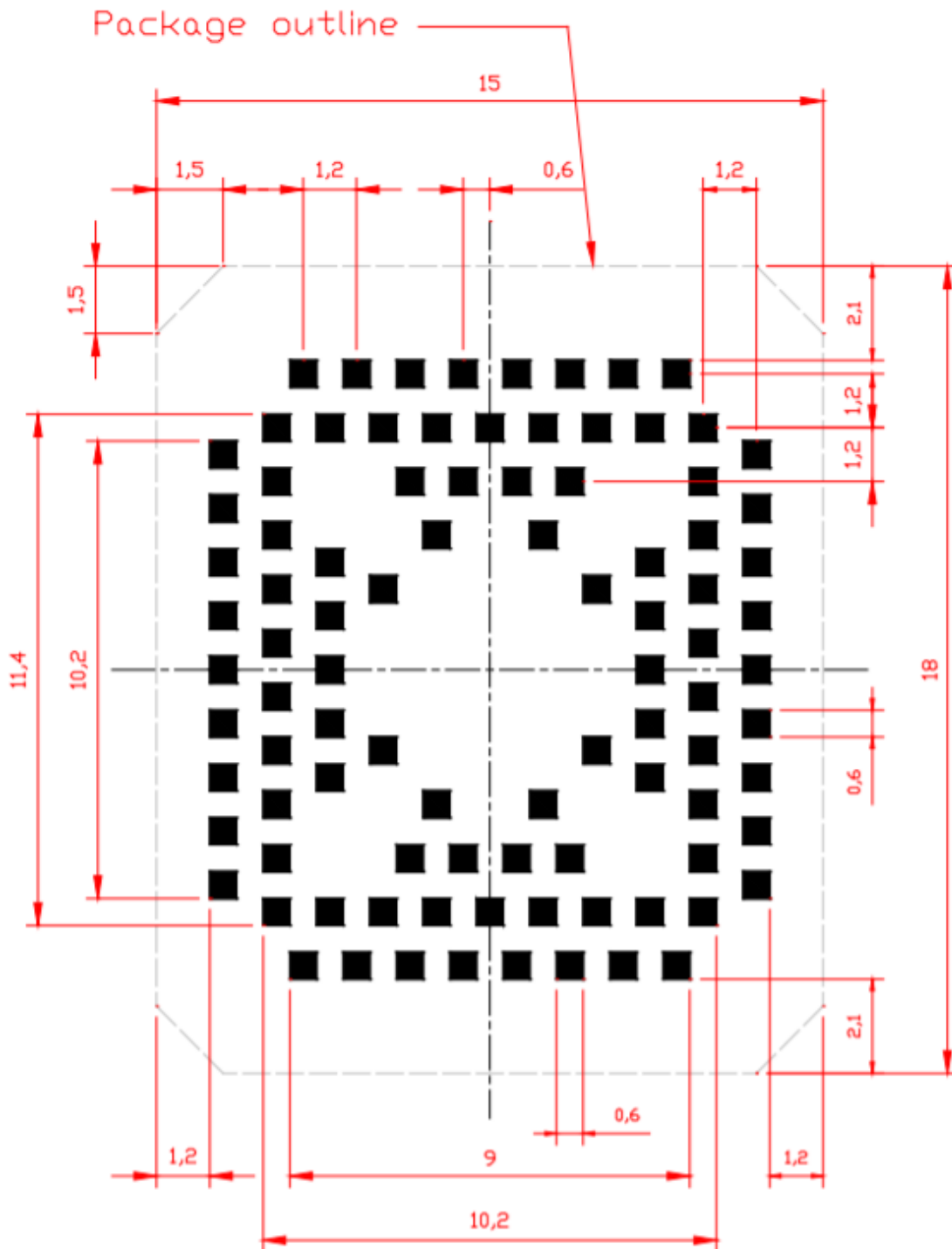

Figure 8: Solder resist pattern (top view)

8.1.2. NE310L2-WW

COPPER PATTERN (top view)



SOLDER RESIST PATTERN (top view)

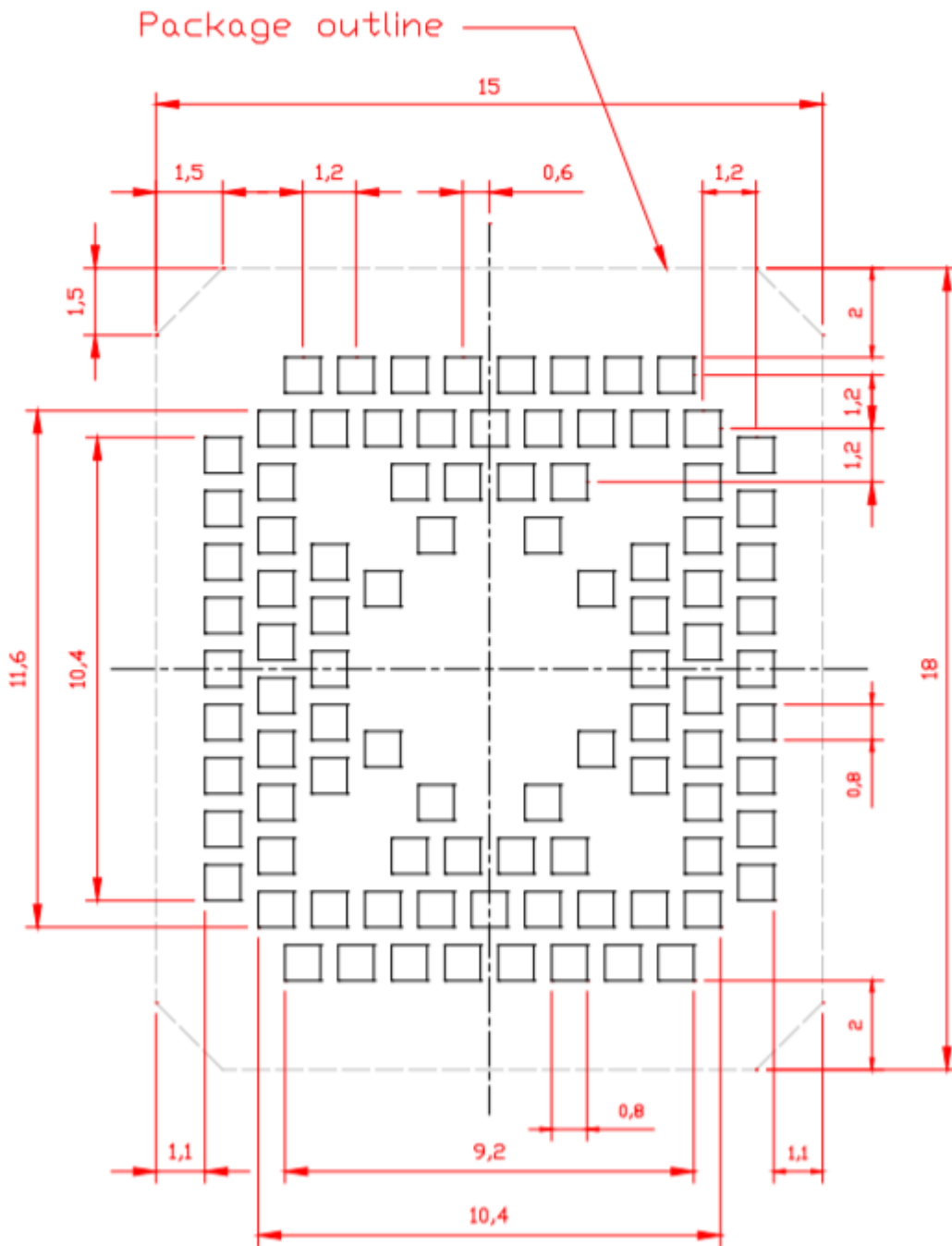

8.1.3. Recommendations for NE310L2-W1

In order to easily rework the NE310L2-W1, it is recommended to consider on the application a 2 mm placement inhibit area around the module.

It is also suggested, as a common rule for an SMT component, to avoid having a mechanical part of the application in direct contact with the module.

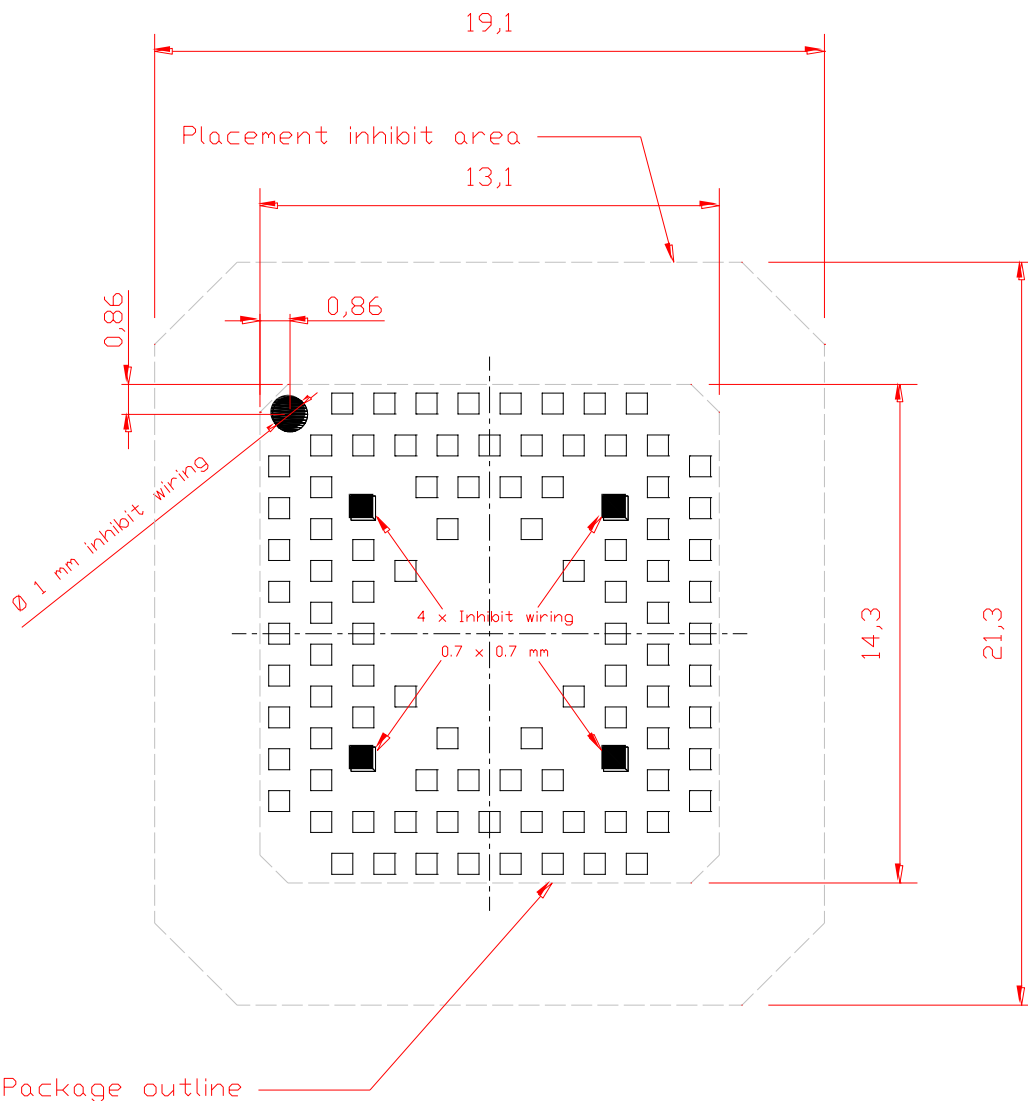

Figure 9: NE310L2-W1 Recommendations



Note: In the customer application, the region under WIRING INHIBIT (see the figure above) must be clear from signal or ground paths.

8.1.4. Recommendations for NE310L2-WW

In order to easily rework the NE310L2-WW, it is recommended to consider on the application a 2 mm placement inhibit area around the module. It is also suggested, as a common rule for an SMT component, to avoid having a mechanical part of the application in direct contact with the module.

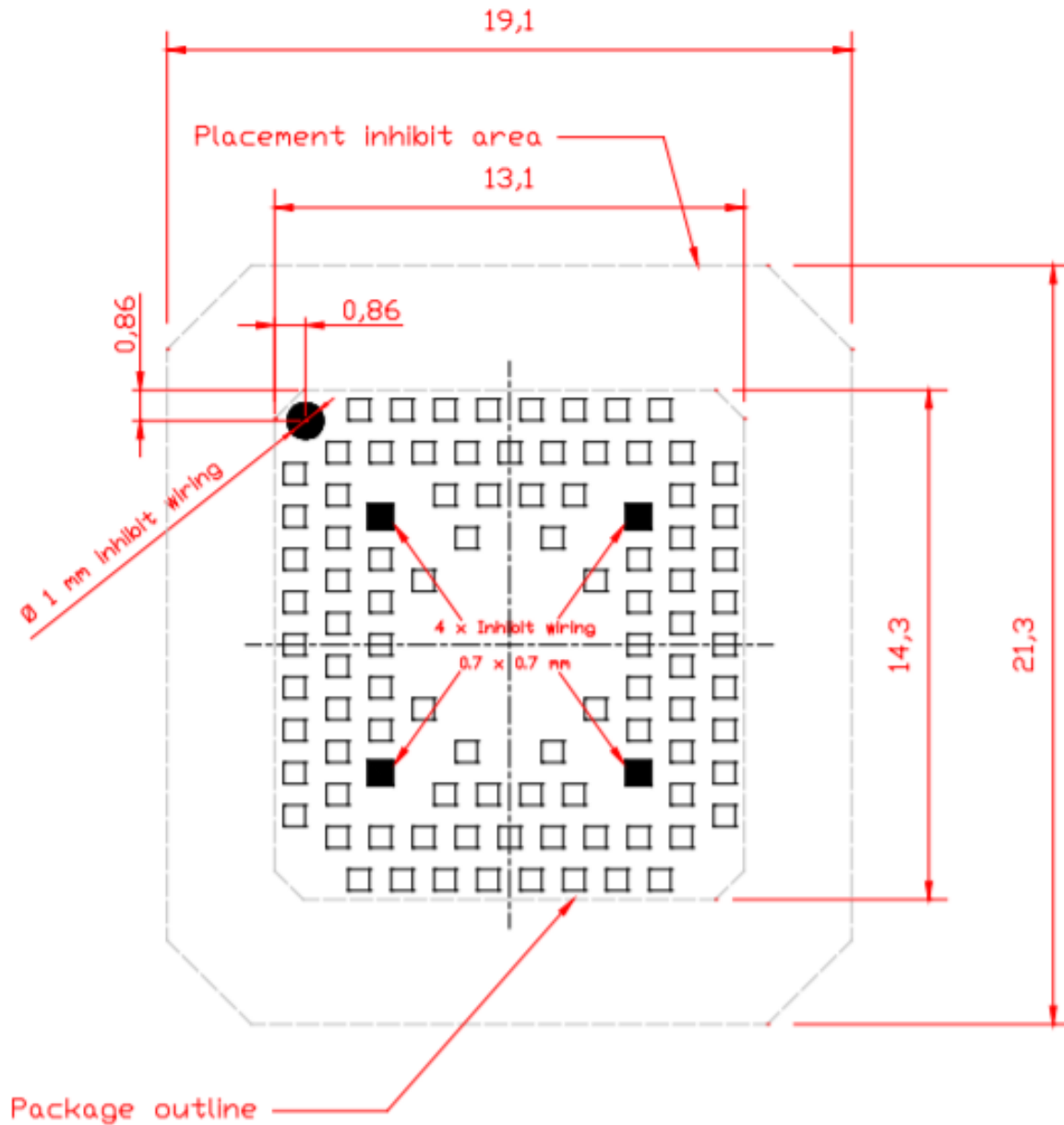

8.2. PCB pad design

Non solder mask defined (NSMD) type is recommended for the solder pads on the PCB.

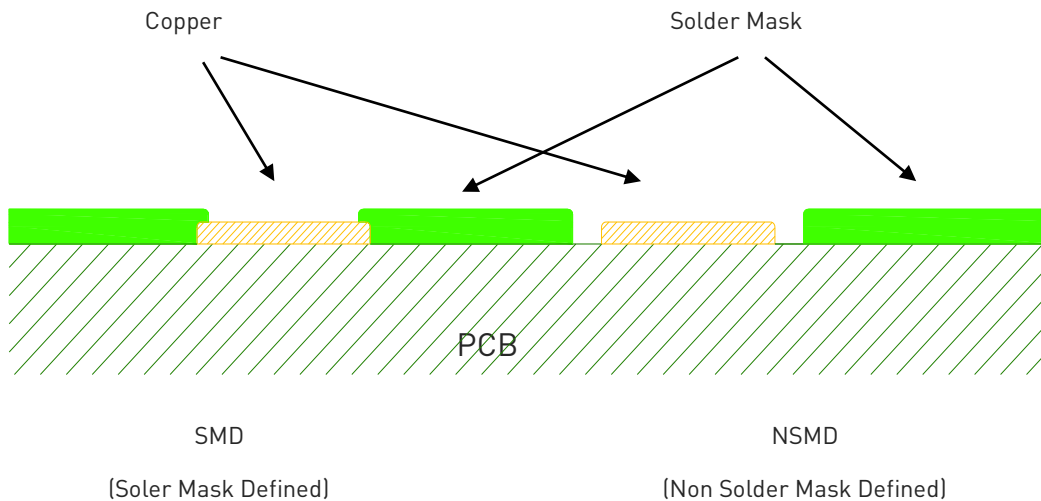

Figure 10: PCB solder pad recommendations

The recommendation for the PCB pads dimensions are 1:1 with module pads.

It is not recommended to place via or micro-via not covered by solder resist in an area of 0.3 mm around the pads unless it carries the same signal of the pad itself

Holes in pad are allowed only for blind holes and not for through holes.

Recommendations for PCB pad surfaces:

Finish	Layer Thickness (um)	Properties
Electro-less Ni / Immersion Au	3 - 7 / 0.03 - 0.15	good solder ability protection, high shear force values

Table 25 Recommendations for PCB pad surfaces

The PCB must be able to resist the higher temperatures that occur during the lead-free process. This issue should be discussed with the PCB-supplier. In general, the wettability of tin-lead solder paste on the described surface plating is better than the lead-free solder paste.

It is not necessary to panel the application's PCB, however in that case it is recommended to use milled contours and pre-drilled board breakouts; scoring or v-cut solutions are not recommended.

8.3. Stencil

The layout of the stencil apertures can be the same as the recommended footprint (1:1), we suggest a thickness of stencil foil $\geq 120 \mu\text{m}$.

8.4. Solder paste

Item	Lead Free
Solder Paste	Sn/Ag/Cu

Table 26: Solder paste

We recommend using only “no clean” solder paste to avoid the cleaning of the modules after assembly.

8.5. Solder Reflow

Recommended solder reflow profile:

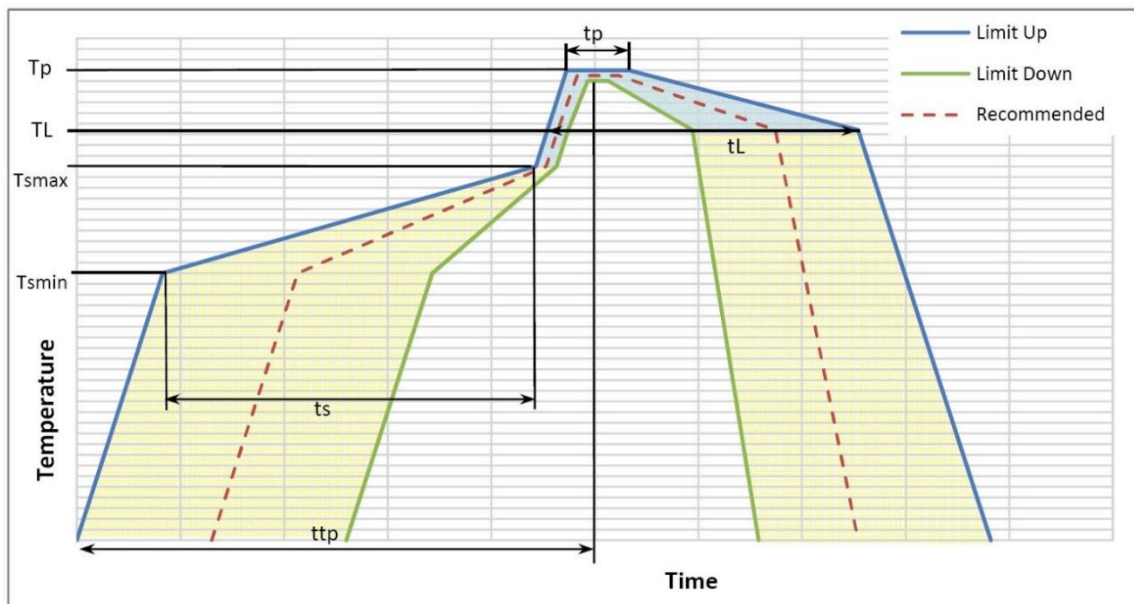

Figure 11: Recommended Solder reflow profile



Warning: The aforementioned solder reflow profile represents the typical SAC reflow limits and does not guarantee the adequate adherence of the module to the customer application throughout the temperature range. The customer must optimize the reflow profile based on the overall system taking into account factors such as thermal mass and warpage.

Profile Feature	Pb-Free Assembly
Average ramp-up rate (TL to Tp)	3°C/second max
Preheat – Temperature Min (T _{min}) – Temperature Max (T _{max}) – Time (min to max) (ts)	150°C 200°C 60-180 seconds
T _{max} to TL – Ramp-up Rate	3°C/second max
Time maintained above: – Temperature (TL) – Time (tL)	217°C 60-150 seconds
Peak Temperature (Tp)	245 +0/-5°C
Time within 5°C of actual Peak Temperature (tp)	10-30 seconds
Ramp-down Rate	6°C/second max.
Time 25°C to Peak Temperature	8 minutes max.

Table 27 Profile feature recommendations



Note: All temperatures refer to topside of the package, measured on the package body surface



Warning: THE NE310L2 MODULES WITHSTANDS ONE REFLOW PROCESS ONLY.



Warning: The aforementioned solder reflow profile represents the typical SAC reflow limits and does not guarantee the adequate adherence of the module to the customer application throughout the temperature range. The customer must optimize the reflow profile depending on the overall system, taking into account factors such as thermal mass and warpage.

9. PACKAGING

9.1. Tray

9.1.1. NE310L2-W1

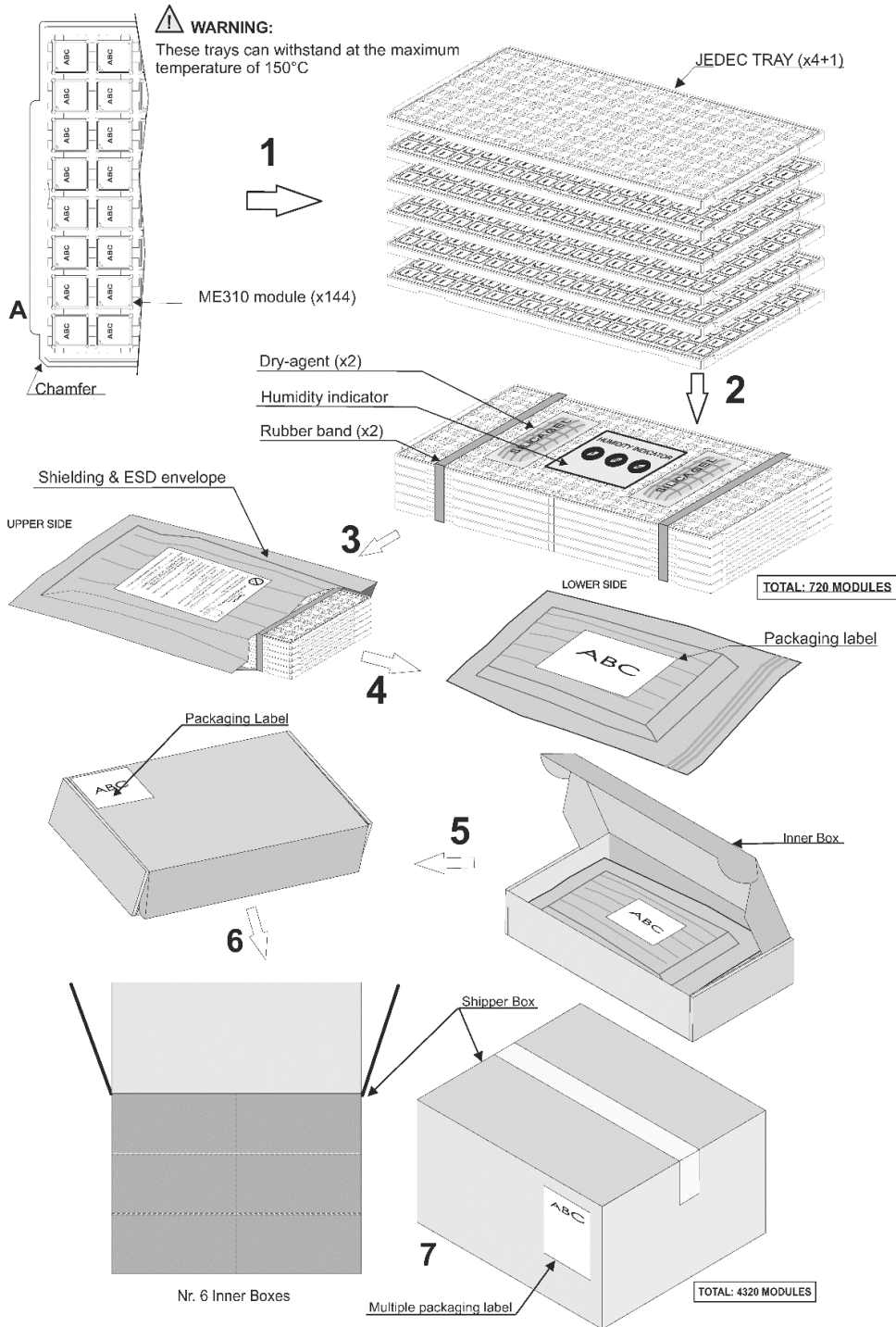
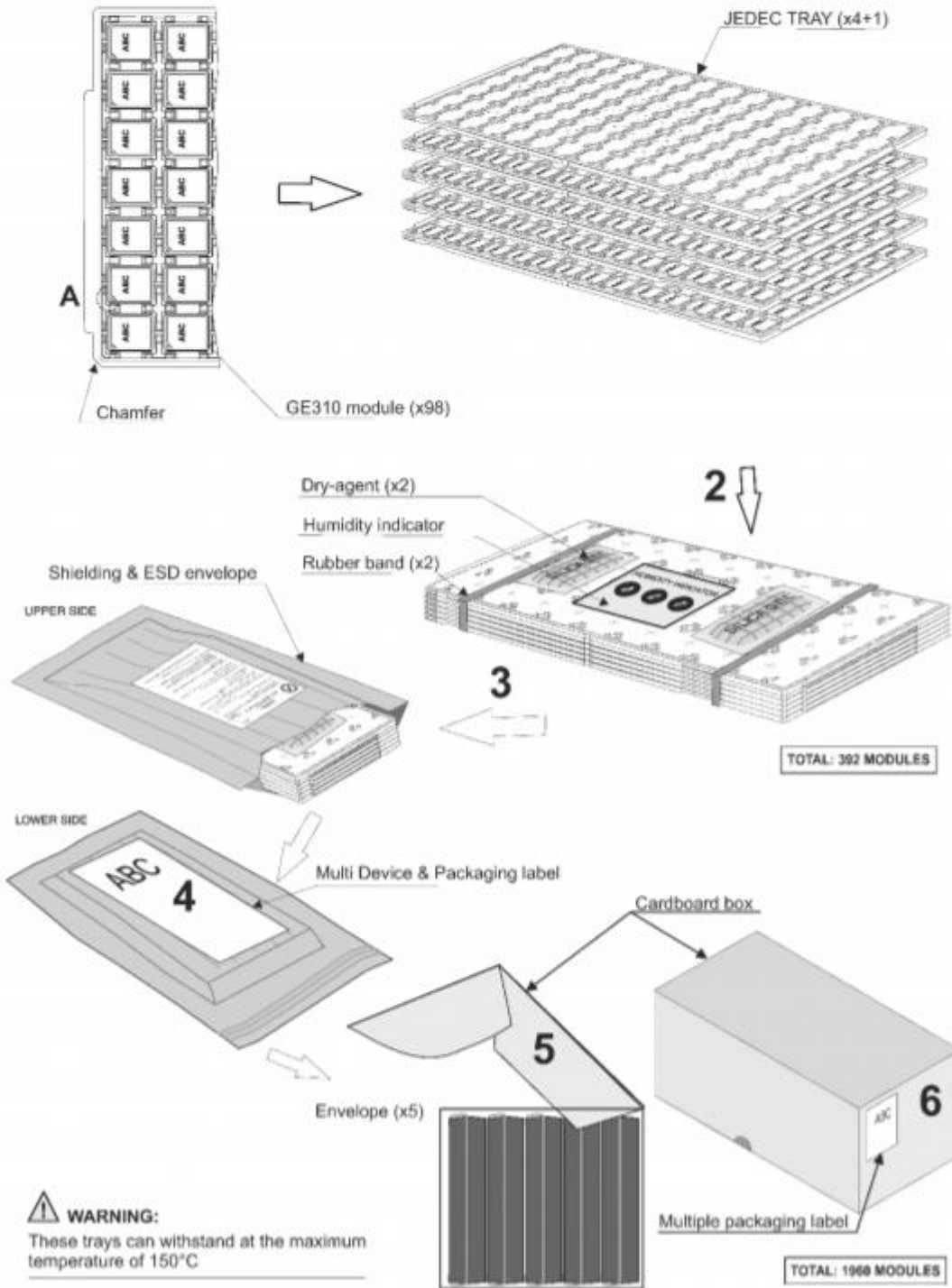
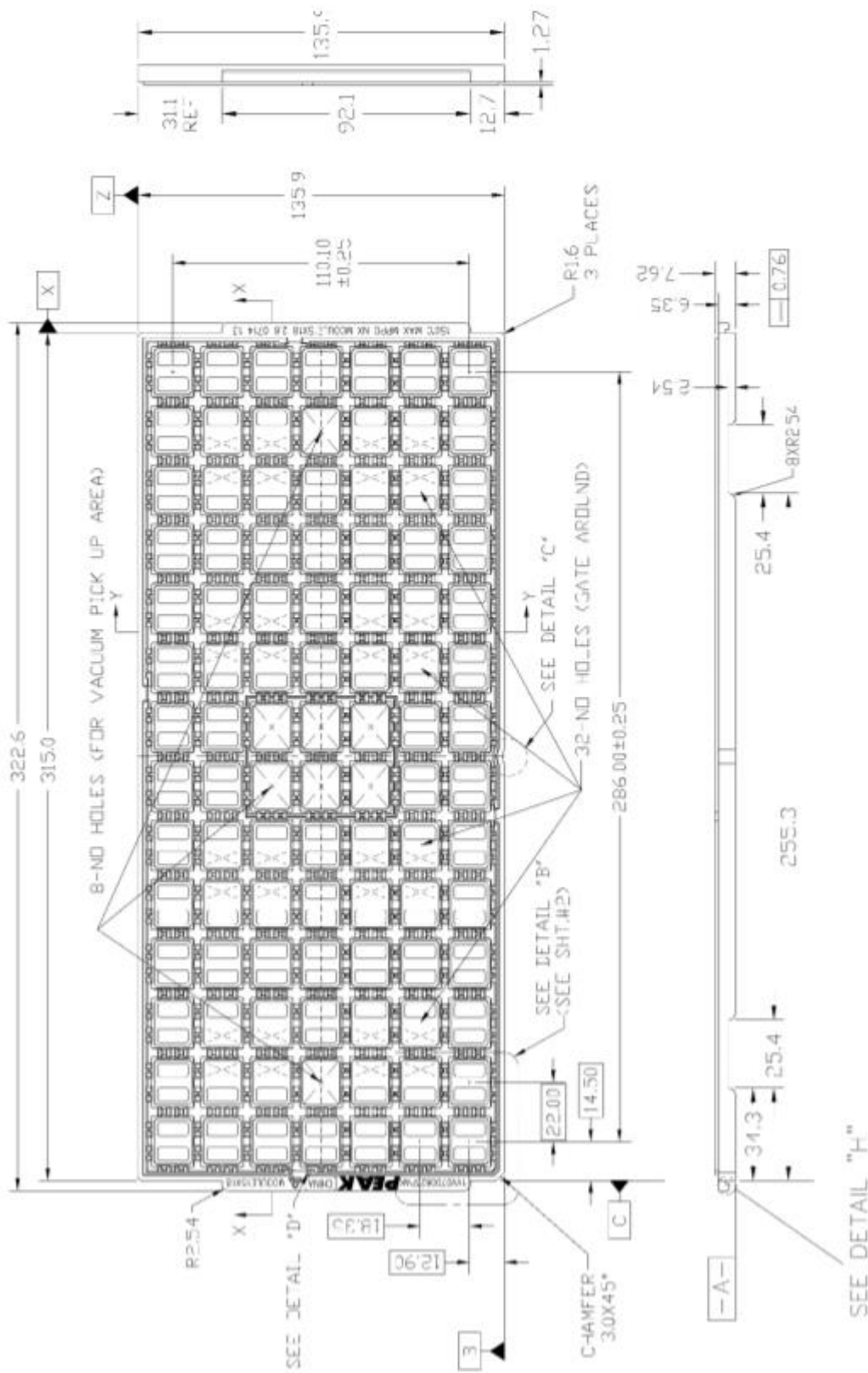

Figure 12: NE310L2-W1 tray packaging

9.1.2. NE310L2-WW





9.2. Reel

9.2.1. NE310L2-W1

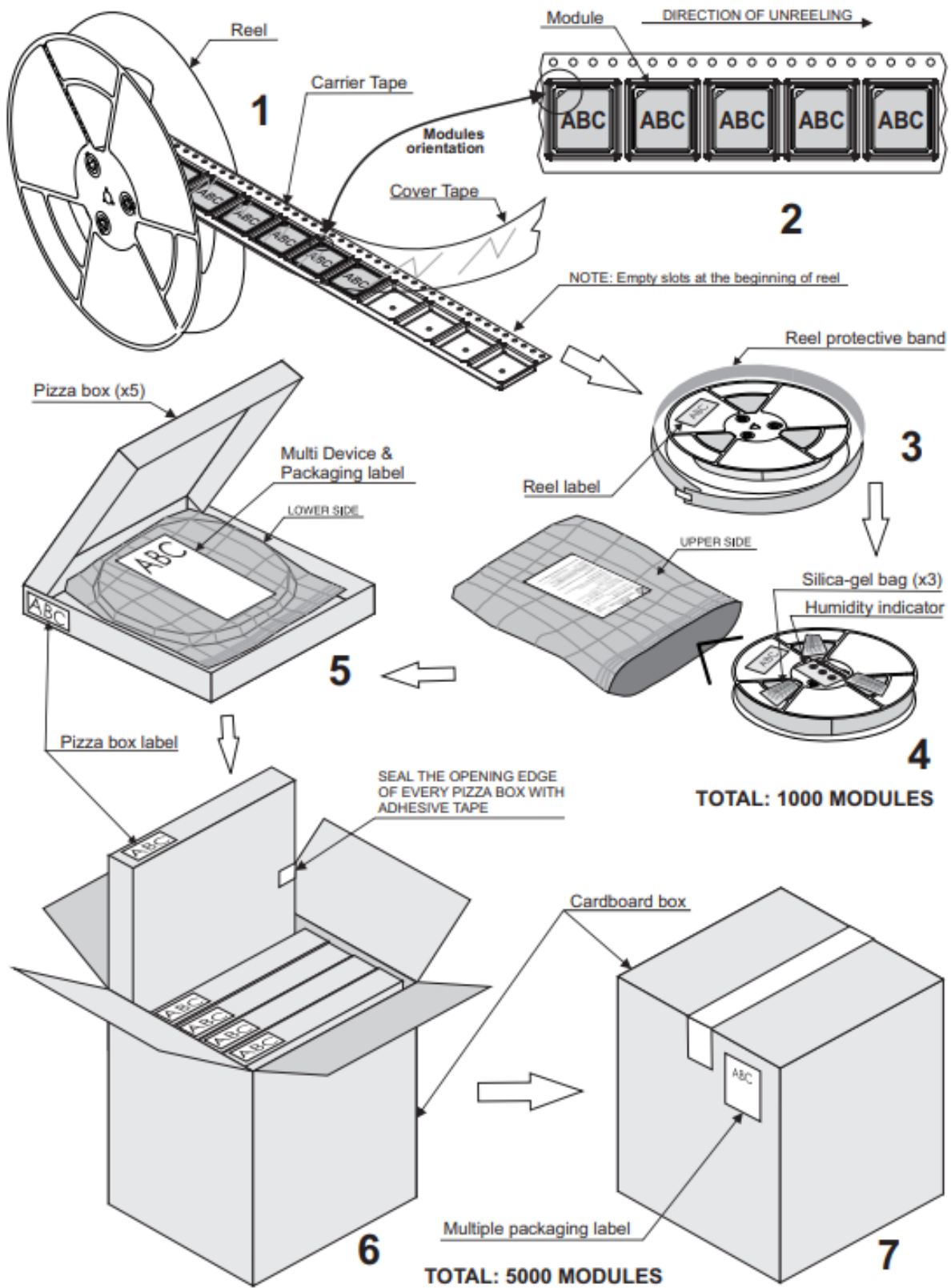

9.2.2. NE310L2-WW

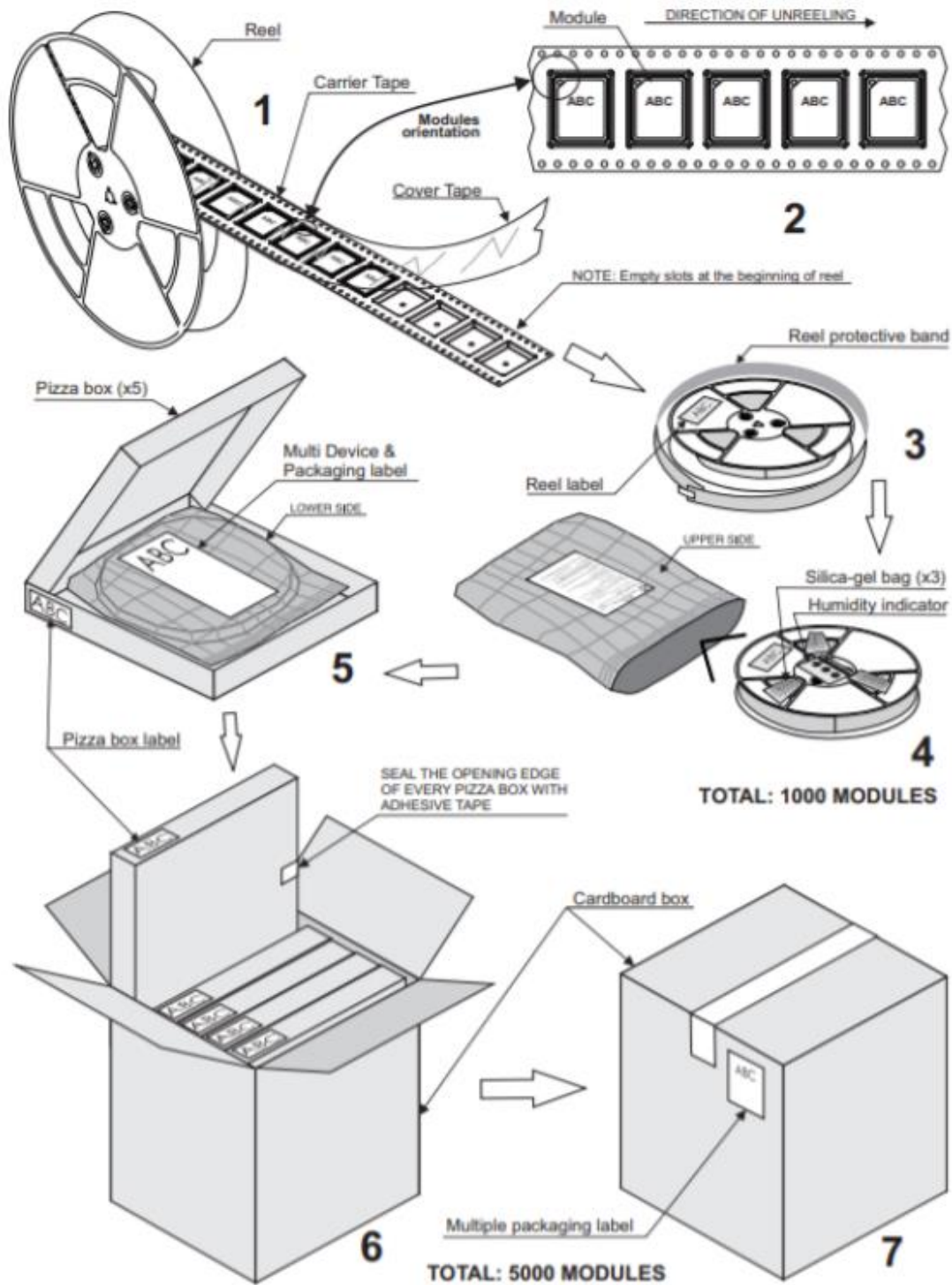

10. CONFORMITY ASSESSMENT ISSUES

10.1. Approvals summary

Type Approval	NE310L2-W1	NE310L2-WW
EU RED	Ongoing	Ongoing
US FCC	Ongoing	Ongoing
CA ISED	Ongoing	Ongoing

Table 28: Type approvals summary

10.2. RED approval

10.2.1. RED Declaration of Conformity

Hereby, Telit Communications S.p.A declares that the NE310L2-W1 and NE310L2-WW Modules are in compliance with Directive 2014/53/EU.

The full text of the EU declaration of conformity is available at the following internet address: <http://www.telit.com/red> Text of 2014/53/EU Directive (RED) can be found here:

<https://eur-lex.europa.eu/legal-content/EN/TXT/?uri=CELEX:32014L0053>

10.2.2. RED Antennas

This radio transmitter has been approved under RED to operate with the antenna types listed below with the maximum permissible gain indicated. The usage of a different antenna in the final hosting device may need a new assessment of host conformity to RED.

Model	Antenna Type
NE310L2-W1	Omnidirectional Antenna Gain 2.14 dBi
NE310L2-WW	

Table 29: RED Antenna Type

Max Gain for RED (dBi)		
Band	NE310L2-W1	NE310L2-WW
GPRS 900	---	6.0
GPRS 1800	---	9.0

FDD 1	11.8	11.8
FDD 3	11.3	11.3
FDD 8	8.4	8.4
FDD 20	8.2	8.2
FDD 28	7.4	7.4

Table 30: Max Gain for RED

10.3. FCC and ISED approval / *FCC et ISDE approbation*

10.3.1. FCC certificates

The FCC Certificate is available here:

<https://www.fcc.gov/oet/ea/fccid>

10.3.2. ISED Certificate / *ISDE certificates*

The ISED Certificate is available here / *Le certificat ISDE est disponible ici:*

<https://sms-sgs.ic.gc.ca/equipmentSearch/searchRadioEquipments?execution=e1s1&lang=en>

10.3.3. Applicable FCC and ISED rules / *Liste des règles FCC et ISDE applicables*

Model Modèle	Applicable FCC Rules	Applicable ISED Rules Règles ISDE applicables
NE310L2-W1	47 CFR Part 2, 22, 24, 27, 90	RSS: 132 Issue3, 133 Issue 6, 130 Issue 2, 139 Issue 3; RSS-Gen Issue 5
NE310L2-WW		

Table 31 Applicable FCC and ISED rules

10.3.4. FCC and ISED Regulatory notices / Avis réglementaires de FCC et ISDE

Modification statement / Déclaration de modification

Telit does not approve any changes or modifications to this device by the user. Any changes or modifications could void the user's authority to operate the equipment.

Telit n'approuve aucune modification apportée à l'appareil par l'utilisateur, quelle qu'en soit la nature. Tout changement ou modification peuvent annuler le droit d'utilisation de l'appareil par l'utilisateur.

Interference statement / Déclaration d'interférence

This device complies with Part 15 of the FCC Rules and Industry Canada licence-exempt RSS standard(s). Operation is subject to the following two conditions: (1) this device may not cause interference, and (2) this device must accept any interference, including interference that may cause undesired operation of the device.

Le présent appareil est conforme aux CNR d'Industrie Canada applicables aux appareils radio exempts de licence. L'exploitation est autorisée aux deux conditions suivantes : (1) l'appareil ne doit pas produire de brouillage, et (2) l'utilisateur de l'appareil doit accepter tout brouillage radioélectrique subi, même si le brouillage est susceptible d'en compromettre le fonctionnement.

Wireless notice / Wireless avis

This device complies with FCC/ISED radiation exposure limits set forth for an uncontrolled environment and meets the FCC radio frequency (RF) Exposure Guidelines and RSS-102 of the ISED radio frequency (RF) Exposure rules. This transmitter must not be co-located or operate in conjunction with any other antenna or transmitter. The antenna should be installed and operated with minimum distance of 20 cm between the radiator and your body.

Le présent appareil est conforme à l'exposition aux radiations FCC / ISED définies pour un environnement non contrôlé et répond aux directives d'exposition de la fréquence de la FCC radiofréquence (RF) et RSS-102 de la fréquence radio (RF) ISED règles d'exposition. L'émetteur ne doit pas être colocalisé ni fonctionner conjointement avec à autre antenne ou autre émetteur. L'antenne doit être installée de façon à garder une distance minimale de 20 centimètres entre la source de rayonnements et votre corps.

FCC Class B digital device notice (FCC only)

This equipment has been tested and found to comply with the limits for a Class B digital device, pursuant to part 15 of the FCC Rules. These limits are designed to provide reasonable protection against harmful interference in a residential installation. This

equipment generates, uses and can radiate radio frequency energy and, if not installed and used in accordance with the instructions, may cause harmful interference to radio communications. However, there is no guarantee that interference will not occur in a particular installation. If this equipment does cause harmful interference to radio or television reception, which can be determined by turning the equipment off and on, the user is encouraged to try to correct the interference by taking one or more of the following measures:

Reorient or relocate the receiving antenna.

- Increase the separation between the equipment and the receiver.
- Connect the equipment into an outlet on a circuit different from that to which the receiver is connected.
- Consult the dealer or an experienced radio/TV technician for help.

CAN ICES-3 (B) / NMB-3 (B) (ISED only) / *(ISDE seulement)*

This Class B digital apparatus complies with Canadian ICES-003.

Cet appareil numérique de classe B est conforme à la norme canadienne ICES-003.

10.3.5. FCC/ISED Antennas / *FCC/ISDE Antennes*

FCC

This radio transmitter has been approved by FCC and ISED to operate with the antenna types listed below with the maximum allowable gain indicated. Antenna types not included in this list, with a gain greater than the maximum gain indicated for that type, are strictly prohibited for use with this device.

Model	Antenna Type
NE310L2-W1	Omnidirectional Antenna Gain 2.14 dBi
NE310L2-WW	

Table 32 FCC Antenna Type

Max Gain for FCC (dBi)		
Band	NE310L2-W1	NE310L2-WW
GPRS 850	---	6.9
GPRS 1900	---	8.5
FDD 2	8.0	8.0

Max Gain for FCC (dBi)		
FDD 4	5.0	5.0
FDD 5	9.4	9.4
FDD 12	8.6	8.6
FDD 13	9.1	9.1
FDD 25	8.0	8.0
FDD 26	9.3	9.3
FDD 66	5.0	5.0
FDD 85	8.6	8.6

Table 33: Max Gain for FCC (dBi)

ISED / ISDE

This radio transmitter has been approved by ISED to operate with the antenna types listed below with the maximum allowable gain indicated. Antenna types not included in this list, with a gain greater than the maximum gain indicated for that type, are strictly prohibited for use with this device.

Le présent émetteur radio a été approuvé par ISDE pour fonctionner avec les types d'antenne énumérés ci-dessous et ayant un gain admissible maximal. Les types d'antenne non inclus dans cette liste, et dont le gain est supérieur au gain maximal indiqué, sont strictement interdits pour l'exploitation de l'émetteur.

Model Modèle	Antenna Type Type d'Antenne
NE310L2-W1	Omnidirectional Antenna Gain 2.14 dBi
NE310L2-WW	Omnidirectionelle Gain de l'antenne 2.14 dBi

Table 34: ISED Antenna Type

Gain maximum for ISED (dBi) / Gain maximum pour ISDE (dBi)		
Bande	NE310L2-W1	NE310L2-WW
GPRS 850	---	6.9
GPRS 1900	---	8.5
FDD 2	8.0	8.0
FDD 4	5.0	5.0
FDD 5	6.1	6.1
FDD 12	5.6	5.6
FDD 13	5.9	5.9

Gain maximum for ISED (dBi) / <i>Gain maximum pour ISDE (dBi)</i>		
FDD 25	8.0	8.0
FDD 26	6.0	6.0
FDD 66	5.0	5.0
FDD 85	5.6	5.6

Table 35: Gain maximum for ISED (dBi)

10.3.6. FCC label and compliance information

The product has a FCC ID label on the device itself. In addition, the OEM host end product manufacturer will be informed to display a label referring to the enclosed module. The external label will read as follows: "Contains Transmitter Module FCC ID: RI7NE310L2W1" or "Contains FCC ID: RI7NE310L2W1" for NE310L2-W1 and : "Contains Transmitter Module FCC ID: RI7NE310L2WW" or "Contains FCC ID: RI7NE310L2WW" for NE310L2-WW.

Below list of all the models and related FCC ID:

Model	FCC ID
NE310L2-W1	RI7NE310L2W1
NE310L2-WW	RI7NE310L2WW

Table 36: FCC ID

10.3.7. ISED label and compliance information / *Étiquette et informations de conformité ISDE*

The host product shall be properly labelled to identify the modules within the host product.

The ISED certification label of a module shall be clearly visible at all times when installed in the host product; otherwise, the host product must be labelled to display the ISED certification number for the module, preceded by the word "contains" or similar wording expressing the same meaning, as follows:

Contains IC: XXXXXX-YYYYYYYYYYY

In this case, XXXXXX-YYYYYYYYYYY is the module's certification number.

Le produit hôte devra être correctement étiqueté, de façon à permettre l'identification des modules qui s'y trouvent.

L'étiquette d'homologation d'un module d'ISDE devra être apposée sur le produit hôte à un endroit bien en vue, en tout temps. En l'absence d'étiquette, le produit hôte doit porter une étiquette sur laquelle figure le numéro d'homologation du module d'ISDE, précédé du mot « contient », ou d'une formulation similaire allant dans le même sens et qui va comme suit:

Contient IC : XXXXXX-YYYYYYYYYYY

Dans ce cas, XXXXXX-YYYYYYYYYYY est le numéro d'homologation du module.

Model Modèle	ISED Certification Number Num. de certification ISDE
NE310L2-W1	5131A-NE310L2W1
NE310L2-WW	5131A-NE310L2WW

Table 37: ISED Certification Number

10.3.8. Information on test modes and additional testing requirements / Informations sur les modes de test et les exigences de test supplémentaires

The module has been evaluated in mobile stand-alone conditions. For different operational conditions other than a stand-alone modular transmitter in a host (multiple, simultaneously transmitting modules or other transmitters in a host), additional testing may be required (collocation, retesting...)

If this module is intended for use in a portable device, the user is responsible for separate approval to meet the SAR requirements of FCC Part 2.1093 and IC RSS-102.

Le module a été évalué dans des conditions autonomes mobiles. Pour différentes conditions de fonctionnement d'un émetteur modulaire autonome dans un hôte (plusieurs modules émettant simultanément ou d'autres émetteurs dans un hôte), des tests supplémentaires peuvent être nécessaires (colocalisation, retesting...)

Si ce module est destiné à être utilisé dans un appareil portable, vous êtes responsable de l'approbation séparée pour satisfaire aux exigences SAR de la FCC Partie 2.1093 et IC RSS-102.

10.3.9.FCC Additional testing, Part 15 Subpart B disclaimer

The modular transmitter is only FCC authorized for the specific rule parts (i.e., FCC transmitter rules) listed on the license, and that the host product manufacturer is responsible for compliance with any other FCC rules that apply to the host not covered by the modular transmitter grant of certification. If the beneficiary markets his product as compliant with Part 15 Subpart B (when it also contains unintentional-radiator digital circuitry), then the beneficiary must communicate that the final host product still requires compliance tests of Part 15 Subpart B with the modular transmitter installed. The end product with an embedded module may also need to pass the FCC Part 15 unintentional emission testing requirements and be properly authorized in accordance with FCC Part 15.

11. PRODUCT AND SAFETY INFORMATION

11.1. Copyrights and Other Notices

SPECIFICATIONS ARE SUBJECT TO CHANGE WITHOUT NOTICE

Although reasonable efforts have been made to ensure the accuracy of this document, Telit assumes no liability resulting from any inaccuracies or omissions in this document, or from the use of the information contained herein. The information in this document has been carefully checked and is believed to be reliable. Telit reserves the right to make changes to any of the products described herein, to revise it and to make changes from time to time with no obligation to notify anyone of such revisions or changes. Telit does not assume any liability arising from the application or use of any product, software, or circuit described herein; neither does it convey license under its patent rights or the rights of others.

This document may contain references or information about Telit's products (machines and programs), or services that are not announced in your country. Such references or information do not necessarily mean that Telit intends to announce such Telit products, programming, or services in your country.

11.1.1. Copyrights

This instruction manual and the Telit products described herein may include or describe Telit's copyrighted material, such as computer programs stored in semiconductor memories or other media. Laws in Italy and in other countries reserve to Telit and its licensors certain exclusive rights for copyrighted material, including the exclusive right to copy, reproduce in any form, distribute and make derivative works of the copyrighted material. Accordingly, any of Telit's or its licensors' copyrighted material contained herein or described in this instruction manual, shall not be copied, reproduced, distributed, merged or modified in any manner without the express written permission of the owner. Furthermore, the purchase of Telit's products shall not be deemed to grant in any way, neither directly nor by implication, or estoppel, any license.

11.1.2. Computer Software Copyrights

Telit and the 3rd Party supplied Software (SW) products, described in this instruction manual may include Telit's and other 3rd Party's copyrighted computer programs stored in semiconductor memories or other media. Laws in Italy and in other countries reserve to Telit and other 3rd Party SW exclusive rights for copyrighted computer programs,

including – but not limited to - the exclusive right to copy or reproduce in any form the copyrighted products. Accordingly, any copyrighted computer programs contained in Telit's products described in this instruction manual shall not be copied (reverse engineered) or reproduced in any manner without the express written permission of the copyright owner, being Telit or the 3rd Party software supplier. Furthermore, the purchase of Telit products shall not be deemed to grant either directly or by implication, estoppel, or in any other way, any license under the copyrights, patents or patent applications of Telit or other 3rd Party supplied SW, except for the normal non-exclusive, royalty free license to use arising by operation of law in the sale of a product.

11.2. Usage and Disclosure Restrictions

11.2.1. License Agreements

The software described in this document is owned by Telit and its licensors. It is furnished by express license agreement only and shall be used exclusively in accordance with the terms of such agreement.

11.2.2. Copyrighted Materials

The Software and the documentation are copyrighted materials. Making unauthorized copies is prohibited by the law. The software or the documentation shall not be reproduced, transmitted, transcribed, even partially, nor stored in a retrieval system, nor translated into any language or computer language, in any form or by any means, without prior written permission of Telit.

11.2.3. High Risk Materials

Components, units, or third-party goods used in the making of the product described herein are NOT fault-tolerant and are NOT designed, manufactured, or intended for use as on-line control equipment in the following hazardous environments requiring fail-safe controls: operations of Nuclear Facilities, Aircraft Navigation or Aircraft Communication Systems, Air Traffic Control, Life Support, or Weapons Systems ("High Risk Activities"). Telit and its supplier(s) specifically disclaim any expressed or implied warranty of fitness eligibility for such High Risk Activities.

11.2.4. Trademarks

TELIT and the Stylized T-Logo are registered in the Trademark Office. All other product or service names are property of their respective owners.

11.2.5. 3rd Party Rights

The software may include 3rd Party's software Rights. In this case the user agrees to comply with all terms and conditions imposed in respect of such separate software rights. In addition to 3rd Party Terms, the disclaimer of warranty and limitation of liability provisions in this License, shall apply to the 3rd Party Rights software as well.

TELIT HEREBY DISCLAIMS ANY AND ALL WARRANTIES EXPRESSED OR IMPLIED FROM ANY 3RD PARTY REGARDING ANY SEPARATE FILES, ANY 3RD PARTY MATERIALS INCLUDED IN THE SOFTWARE, ANY 3RD PARTY MATERIALS FROM WHICH THE SOFTWARE IS DERIVED (COLLECTIVELY "OTHER CODES"), AND THE USE OF ANY OR ALL OTHER CODES IN CONNECTION WITH THE SOFTWARE, INCLUDING (WITHOUT LIMITATION) ANY WARRANTIES OF SATISFACTORY QUALITY OR FITNESS FOR A PARTICULAR PURPOSE.

NO 3RD PARTY LICENSORS OF OTHER CODES MUST BE LIABLE FOR ANY DIRECT, INDIRECT, INCIDENTAL, SPECIAL, EXEMPLARY, OR CONSEQUENTIAL DAMAGES (INCLUDING WITHOUT LIMITATION LOST OF PROFITS), HOWEVER CAUSED AND WHETHER MADE UNDER CONTRACT, TORT OR OTHER LEGAL THEORY, ARISING IN ANY WAY OUT OF THE USE OR DISTRIBUTION OF THE OTHER CODES OR THE EXERCISE OF ANY RIGHTS GRANTED UNDER EITHER OR BOTH THIS LICENSE AND THE LEGAL TERMS APPLICABLE TO ANY SEPARATE FILES, EVEN IF ADVISED OF THE POSSIBILITY OF SUCH DAMAGES.

11.2.6. Waiver of Liability

IN NO EVENT WILL TELIT AND ITS AFFILIATES BE LIABLE FOR ANY DIRECT, INDIRECT, SPECIAL, GENERAL, INCIDENTAL, CONSEQUENTIAL, PUNITIVE OR EXEMPLARY INDIRECT DAMAGE OF ANY KIND WHATSOEVER, INCLUDING BUT NOT LIMITED TO REIMBURSEMENT OF COSTS, COMPENSATION OF ANY DAMAGE, LOSS OF PRODUCTION, LOSS OF PROFIT, LOSS OF USE, LOSS OF BUSINESS, LOSS OF DATA OR REVENUE, WHETHER OR NOT THE POSSIBILITY OF SUCH DAMAGES COULD HAVE BEEN REASONABLY FORESEEN, CONNECTED IN ANY WAY TO THE USE OF THE PRODUCT/S OR TO THE INFORMATION CONTAINED IN THE PRESENT DOCUMENTATION, EVEN IF TELIT AND/OR ITS AFFILIATES HAVE BEEN ADVISED OF THE POSSIBILITY OF SUCH DAMAGES OR THEY ARE FORESEEABLE OR FOR CLAIMS BY ANY THIRD PARTY.

11.3. Safety Recommendations

Make sure the use of this product is allowed in your country and in the environment required. The use of this product may be dangerous and has to be avoided in areas where:

- it can interfere with other electronic devices, particularly in environments such as hospitals, airports, aircrafts, etc.
- there is a risk of explosion such as gasoline stations, oil refineries, etc. It is the responsibility of the user to enforce the country regulation and the specific environment regulation.

Do not disassemble the product; any mark of tampering will compromise the warranty validity. We recommend following the instructions of the hardware user guides for correct wiring of the product. The product has to be supplied with a stabilized voltage source and the wiring has to be conformed to the security and fire prevention regulations. The product has to be handled with care, avoiding any contact with the pins because electrostatic discharges may damage the product itself. Same cautions have to be taken for the SIM, checking carefully the instruction for its use. Do not insert or remove the SIM when the product is in power saving mode.

The system integrator is responsible for the functioning of the final product. Therefore, the external components of the module, as well as any project or installation issue, have to be handled with care. Any interference may cause the risk of disturbing the GSM network or external devices or having an impact on the security system. Should there be any doubt, please refer to the technical documentation and the regulations in force. Every module has to be equipped with a proper antenna with specific characteristics. The antenna has to be installed carefully in order to avoid any interference with other electronic devices and has to guarantee a minimum distance from the body (20 cm). In case this requirement cannot be satisfied, the system integrator has to assess the final product against the SAR regulation.

The equipment is intended to be installed in a restricted area location.

The equipment must be supplied by an external specific limited power source in compliance with the standard EN 62368-1:2014.

The European Community provides some Directives for the electronic equipment introduced on the market. All of the relevant information is available on the European Community website:

https://ec.europa.eu/growth/sectors/electrical-engineering_en

12. GLOSSARY

ADC	Analog – Digital Converter
BPSK	Modulation used for in OFDM symbols
CLK	Clock
CMOS	Complementary Metal – Oxide Semiconductor
CS	Chip Select
DAC	Digital – Analog Converter
DTE	Data Terminal Equipment
DVI	Digital Voice Interface
EM	Electromagnetic
EMC	Electromagnetic Compatibility
EMI	Electromagnetic Interference
ESR	Equivalent Series Resistance
FDD	Frequency Division Duplexing
GPIO	General Purpose Input Output
HS	High Speed
HSDPA	High Speed Downlink Packet Access
HSIC	High Speed Inter Chip
HSUPA	High Speed Uplink Packet Access
I/O	Input Output
LTE	Long Term Evolution
MISO	Master Input – Slave Output
MOSI	Master Output – Slave Input
MRDY	Master Ready
NAS	Non-Access Stratum
PCB	Printed Circuit Board
PSM	Power Saving Mode according to 3GPP Rel.12
QPSK	Modulation used for in OFDM symbols

RB	Resource Block; the smallest unit of resources that can be allocated to a user
RF	Radio Frequency
RMC	Reference Measurement Channel; it refers to a 3GPP standardized setting for the channel. For more details, refer to 3GPP TS 36.521-1
RTC	Real Time Clock
RU	Resource Unit (NB IoT Only); the time reported is the length for the specific configuration SC - SC Spacing
SC	Sub Carriers: indicates the number of Sub-Carriers used
SIM	Subscriber Identification Module
SPI	Serial Peripheral Interface
SRDY	Slave Ready
TBS	Transport Block Size
UART	Universal Asynchronous Receiver Transmitter
UMTS	Universal Mobile Telecommunication System
USB	Universal Serial Bus
VNA	Vector Network Analyzer
VSWR	Voltage Standing Wave Ratio
WCDMA	Wideband Code Division Multiple Access

13. DOCUMENT HISTORY

Revision	Date	Changes
0	2021-03-31	First issue
1	2021-06-10	Par 10 Conformity Assessment Issues updated
2	2021-07-16	Updated table 2.5.1; updated Par 10 Conformity Assessment Issues updated



Connect to our site and contact our technical support team for any question

www.telit.com

Telit

Telit reserves all rights to this document and the information contained herein. Products, names, logos and designs described herein may in whole or in part be subject to intellectual property rights. The information contained herein is provided "as is". No warranty of any kind, either express or implied, is made in relation to the accuracy, reliability, fitness for a particular purpose or content of this document. This document may be revised by Telit at any time. For most recent documents, please visit www.telit.com

Copyright © 2020, Telit