



ME910G1

HW Design Guide

1VV0301593 Rev. 7 – 2021-02-02

APPLICABILITY TABLE

PRODUCTS
ME910G1-W1
ME910G1-WW
ME910G1-WWV

CONTENTS

APPLICABILITY TABLE	2
CONTENTS	3
1. INTRODUCTION	8
1.1. Scope	8
1.2. Audience	8
1.3. Contact Information, Support	8
1.4. Symbol Convention	9
1.5. Related Documents	9
2. GENERAL PRODUCT DESCRIPTION	10
2.1. Overview	10
2.2. Product Variants and Frequency Bands	10
2.3. Target Market	11
2.4. Main features	11
2.5. TX Output Power	12
2.5.1. ME910G1-W1	12
2.5.2. ME910G1-WW and ME910G1-WWV	12
2.6. RX Sensitivity	13
2.6.1. ME910G1-W1	13
2.6.2. ME910G1-WW and ME910G1-WWV	15
2.7. Mechanical Specifications	17
2.7.1. Dimensions	17
2.7.2. Weight	17
2.8. Temperature Range	17
3. PINS ALLOCATION	18
3.1. Pin-out	18
3.2. LGA Pads Layout	24
4. POWER SUPPLY	25
4.1. Power Supply Requirements	25
4.2. Power Consumption	26



4.2.1.	Idle mode	26
4.2.2.	ME910G1-W1 Connected Mode	27
4.2.3.	ME910G1-WW and ME910G1-WWV Connected Mode	28
4.3.	General Design Rules	29
4.3.1.	Electrical Design Guidelines of the power supply	29
4.3.1.1.	+5V Source Power Supply Design Guidelines	29
4.3.1.2.	+12V Source Power Supply Design Guidelines	30
4.3.1.3.	Battery Source Power Supply Design Guidelines	31
4.3.2.	Thermal Design Guidelines	31
4.3.3.	Power Supply PCB layout Guidelines	32
4.4.	VAUX Power Output	34
4.5.	RTC Supply	34
5.	DIGITAL SECTION	35
5.1.	Logic Levels	35
5.2.	Power On	36
5.3.	Power Off	40
5.4.	Wake from deep sleep mode	42
5.5.	Unconditional Shutdown	42
5.6.	Fast shut down	45
5.6.1.	Fast Shut Down by Hardware	45
5.6.2.	Fast Shut Down by Software	46
5.7.	Communication ports	47
5.7.1.	USB 2.0 HS	47
5.7.2.	SPI	48
5.7.2.1.	SPI Connections	48
5.7.3.	Serial Ports	49
5.7.3.1.	Modem serial port 1 (USIF0)	49
5.7.3.2.	Modem serial port 2 (USIF1)	50
5.7.3.3.	RS232 level translation	51
5.8.	General purpose I/O	53
5.8.1.	Using a GPIO as INPUT	53
5.8.2.	Using a GPIO as OUTPUT	54

5.8.3.	Indication of network service availability	54
5.9.	External SIM Holder	55
5.10.	ADC Converter	55
6.	RF SECTION	57
6.1.	Antenna requirements	57
6.1.1.	PCB Design guidelines	58
6.1.2.	PCB Guidelines in case of FCC Certification	59
6.1.2.1.	Transmission line design	60
6.1.2.2.	Transmission Line Measurements	60
6.1.2.3.	Antenna Installation Guidelines	62
7.	AUDIO SECTION	63
7.1.	Electrical Characteristics	63
8.	GNSS SECTION	64
8.1.	GNSS Signals Pin-out	64
8.2.	RF Front End Design	64
8.2.1.	Guidelines of PCB line for GNSS Antenna	64
8.2.2.	Hardware-based solution for GNSS and LTE coexistence	65
8.3.	GNSS Antenna Requirements	66
8.3.1.	GNSS Antenna specification	66
8.3.2.	GNSS Antenna – Installation Guidelines	66
8.3.3.	Powering the External LNA (active antenna)	66
8.4.	GNSS Characteristics	68
9.	MECHANICAL DESIGN	69
9.1.	Drawing	69
10.	APPLICATION PCB DESIGN	70
10.1.	Recommended footprint for the application	70
10.2.	PCB pad design	72
10.3.	Recommendations for PCB pad dimensions	73
10.4.	Thermal performance	73
10.5.	Stencil	74
10.6.	Solder paste	75

10.7.	Solder Reflow	75
10.8.	Inspection	76
11.	PACKAGING	77
11.1.	Tray	77
11.2.	Reel	79
11.3.	Carrier Tape detail	79
11.4.	Reel detail	80
11.5.	Packaging detail	81
11.6.	Moisture sensitivity	81
12.	CONFORMITY ASSESSMENT ISSUES	82
12.1.	Approvals summary	82
12.2.	RED approval	82
12.2.1.	RED Declaration of Conformity	82
12.2.2.	Antennas	82
12.3.	FCC and ISED approval/ <i>FCC et ISDE approbation</i>	83
12.3.1.	FCC certificates	83
12.3.2.	ISED Certificate/ <i>ISDE certificates</i>	83
12.3.3.	Applicable FCC and ISED rules/ <i>Liste des règles FCC et ISDE applicables</i>	83
12.3.4.	FCC and ISED Regulatory notices/ <i>Avis réglementaires de FCC et ISDE</i>	84
12.3.5.	Antennas/Antennes	85
12.3.6.	FCC label and compliance information	87
12.3.7.	ISED label and compliance information/ <i>Étiquette et informations de conformité ISDE</i>	88
12.3.8.	Information on test modes and additional testing requirements / <i>Informations sur les modes de test et les exigences de test supplémentaires</i>	88
12.3.9.	FCC Additional testing, Part 15 Subpart B disclaimer	89
12.4.	ANATEL Regulatory Notices	89
12.5.	NCC Regulatory Notices	90
13.	PRODUCT AND SAFETY INFORMATION	91
13.1.	Copyrights and Other Notices	91



13.1.1.	Copyrights	91
13.1.2.	Computer Software Copyrights	91
13.2.	Usage and Disclosure Restrictions	92
13.2.1.	License Agreements	92
13.2.2.	Copyrighted Materials	92
13.2.3.	High Risk Materials	92
13.2.4.	Trademarks	93
13.2.5.	3rd Party Rights	93
13.2.6.	Waiver of Liability	93
13.3.	Safety Recommendations	94
14.	GLOSSARY	95
15.	DOCUMENT HISTORY	96

1. INTRODUCTION

1.1. Scope

Scope of this document is to give a description of some hardware solutions useful for developing a product with the Telit ME910G1 module.

1.2. Audience

This document is intended for Telit customers, in particular system integrators, who are going to implement their applications using our ME910G1 modules.

1.3. Contact Information, Support

For general contact, technical support services, technical questions and report documentation errors contact Telit Technical Support at:

- TS-EMEA@telit.com
- TS-AMERICAS@telit.com
- TS-APAC@telit.com

Alternatively, use:

<http://www.telit.com/support>

For detailed information about where you can buy the Telit modules or for recommendations on accessories and components visit:

<http://www.telit.com>

Our aim is to make this guide as helpful as possible. Keep us informed of your comments and suggestions for improvements.

Telit appreciates feedback from the users on our information.

1.4. Symbol Convention



Danger: This information MUST be followed, or catastrophic equipment failure or personal injury may occur.



Warning: Alerts the user on important steps about the module integration.



Note/Tip: Provides advice and suggestions that may be useful when integrating the module.



Electro-static Discharge: Notifies the user to take proper grounding precautions before handling the product.

Table 1: Symbol Conventions

All dates are in ISO 8601 format, i.e. YYYY-MM-DD.

1.5. Related Documents

- 80000NT10001A - SIM INTEGRATION DESIGN GUIDES Application Note
- 80000NT10060A - xE910 Global Form Factor Application Note
- 80000NT10002A - ANTENNA DETECTION
- 80000NT10003A - Rework procedure for BGA modules
- 80000NT10028A - Event Monitor Application Note

2. GENERAL PRODUCT DESCRIPTION

2.1. Overview

The ME910G1 module is a CATM/ NBIoT communication product which allows integrators to plan on availability for even the longest lifecycle applications, highly recommended for new designs specified for worldwide coverage.

The ME910G1-WWV product is fully voice capable, the digital audio interface make it suitable for applications such as voice enabled alarm panels, mHealth patient monitors and specialty phones such as those for the elderly or sensory-impaired.

The ME910G1 operates with 1.8 V GPIOs, minimizing power consumption and making it even more ideal for application with battery powered and wearable device.

2.2. Product Variants and Frequency Bands

Product	2G Band (MHz)	LTE CATM1	NB IoT	CS Voice VoLTE	Region
ME910G1-W1	-	B1, B2, B3, B4, B5, B8, B12, B13, B18, B19, B20, B25, B26, B27, B28, B66, B85	B1, B2, B3, B4, B5, B8, B12, B13, B18, B19, B20, B25, B26, B28, B66, B71, B85, B86*	N	Worldwide
ME910G1-WW	850, 900, 1800, 1900	B1, B2, B3, B4, B5, B8, B12, B13, B18, B19, B20, B25, B26, B27, B28, B66, B85	B1, B2, B3, B4, B5, B8, B12, B13, B18, B19, B20, B25, B26, B28, B66, B71, B85	N	Worldwide
ME910G1-WWV	850, 900, 1800, 1900	B1, B2, B3, B4, B5, B8, B12, B13, B18, B19, B20, B25, B26, B27, B28, B66, B85	-	Y	Worldwide

Table 2: Product Variants and Frequency Bands

* See note below

Refer to “RF Section” for details information about frequencies and bands.



Note: Cellular technologies and frequency bands that are enabled may vary based on firmware version and firmware configuration used.

Note: “B86” is not a 3GPP band, it means the following:

UL range: 787-788 MHz, DL range: 757-758 MHz



that is available only in module where AT#BNDOPTIONS command contains the string B86. i.e.

AT#BNDOPTIONS?

#BNDOPTIONS: 1,2,3,4,5,8,12,13,18,19,20,25,26,27,28,66,71,85,86

2.3. Target Market

ME910G1 can be used for telematics applications where tamper-resistance, confidentiality, integrity, and authenticity of end-user information are required, for example:

- Telematics services
- Road pricing
- Pay-as-you-drive insurance
- Stolen vehicles tracking
- Internet connectivity

2.4. Main features

Function	Features
Modem	<ul style="list-style-type: none"> • CATM and NBloT technologies • SMS support (text and PDU) • Alarm management • Real Time Clock
Interfaces	<ul style="list-style-type: none"> • USB 2.0 HS (AT command¹, FW upgrade and module diagnostic) • USIF0 Main UART (AT command¹ and FW upgrade) • USIF1 Auxiliary UART (AT Command¹, AppZone diagnostic) • 10 GPIOs • Antenna port

Table 3: Functional features

¹ Functionality depending on ports configuration

2.5. TX Output Power

2.5.1. ME910G1-W1

Band	Mode	3GPP Class	RF power (dBm) Nominal*
B1, B2, B3, B4, B5, B8, B12, B13, B14, B18, B19, B20, B25, B26, B27, B28, B66, B85	(LTE) CAT-M1	5	21
B1, B2, B3, B4, B5, B8, B12, B13, B18, B19, B20, B25, B26, B28, B66, B71, B85, B86	(LTE) CAT-NB2	5	21

Table 4: Transmission Output power

2.5.2. ME910G1-WW and ME910G1-WWV

Band	Mode	Class	RF power (dBm) Nominal*
850/900MHz	GSM/GPRS	4	32.5
	EGPRS	E2	27
1800/1900MHz	GSM/GPRS	1	29.5
	EGPRS	E2	26
B1, B2, B3, B4, B5, B8, B12, B13, B18, B19, B20, B25, B26, B27, B28, B66, B85	(LTE) CAT-M1	3	23
B1, B2, B3, B4, B5, B8, B12, B13, B18, B19, B20, B25, B26, B28, B66, B85	(LTE) CAT-NB2	3	23
B71	(LTE) CAT-NB2	5	21

Table 5: Transmission Output power ME910G1-WW and ME910G1-WWV

* Max output power tolerance range according to 3GPP TS 36.521-1 and 3GPP TS 51.010-1 or better

2.6. RX Sensitivity

2.6.1. ME910G1-W1

Band	REFsens (dBm) Typical	REFsens (dBm)* 3GPP limit
CATM1 / Band1	-107.6	-102.7
CAT M1 / Band2	-108.0	-100.3
CAT M1 / Band3	-107.6	-99.3
CAT M1 / Band4	-107.8	-102.3
CAT M1 / Band5	-107.9	-100.8
CAT M1 / Band8	-107.8	-99.8
CAT M1 / Band12	-107.8	-99.3
CAT M1 / Band13	-108.0	-99.3
CAT M1 / Band18	-108.0	-102.3
CAT M1 / Band19	-108.0	-102.3
CAT M1 / Band20	-107.8	-99.8
CAT M1 / Band25	-108.0	-
CAT M1 / Band26	-108.0	-100.3
CAT M1 / Band27	-108.0	-100.8
CAT M1 / Band28	-107.9	-100.8
CAT M1 / Band66	-107.8	-
CAT M1 / Band85	-107.6	-
CAT NB2 / Band1	-116.8	-108.2
CAT NB2 / Band2	-116.8	-108.2
CAT NB2 / Band3	-116.8	-108.2
CAT NB2 / Band4	-116.7	-
CAT NB2 / Band5	-116.7	-108.2
CAT NB2 / Band8	-116.4	-108.2
CAT NB2 / Band12	-116.8	-108.2
CAT NB2 / Band13	-116.8	-108.2
CAT NB2 / Band18	-116.8	-108.2
CAT NB2 / Band19	-116.8	-108.2

Band	REFsens (dBm) Typical	REFsens (dBm)* 3GPP limit
CAT NB2 / Band20	-116.6	-108.2
CAT NB2 / Band25	-116.8	-
CAT NB2 / Band26	-116.8	-108.2
CAT NB2 / Band28	-116.9	-108.2
CAT NB2 / Band66	-116.6	-108.2
CAT NB2 / Band71	-115.4	-
CAT NB2 / Band85	-116.8	-

Table 6: RX Sensitivity ME910G1-W1

* 3GPP TS 36.521-1 Release 15 Minimum performance requirement

2.6.2. ME910G1-WW and ME910G1-WWV

Band	REFsens (dBm) Typical	3GPP REFsens (dBm)* 3GPP limit
CAT M1 / Band1	-106.3	-102.7
CAT M1 / Band2	-107.3	-100.3
CAT M1 / Band3	-106.6	-99.3
CAT M1 / Band4	-106.7	-102.3
CAT M1 / Band5	-107.1	-100.8
CAT M1 / Band8	-107.3	-99.8
CAT M1 / Band12	-106.5	-99.3
CAT M1 / Band13	-107.9	-99.3
CAT M1 / Band18	-107.6	-102.3
CAT M1 / Band19	-106.8	-102.3
CAT M1 / Band20	-107.4	-99.8
CAT M1 / Band25	-107.0	-
CAT M1 / Band26	-107.0	-100.3
CAT M1 / Band27	-107.4	-100.8
CAT M1 / Band28	-107.8	-100.8
CAT M1 / Band66	-106.7	-
CAT M1 / Band85	-105.3	-
CAT NB2 / Band1	-115.4	-108.2
CAT NB2 / Band2	-116.2	-108.2
CAT NB2 / Band3	-116.4	-108.2
CAT NB2 / Band4	-115.6	-
CAT NB2 / Band5	-116.5	-108.2
CAT NB2 / Band8	-115.9	-108.2
CAT NB2 / Band12	-116.6	-108.2
CAT NB2 / Band13	-116.8	-108.2
CAT NB2 / Band18	-116.6	-108.2
CAT NB2 / Band19	-116.4	-108.2
CAT NB2 / Band20	-116.0	-108.2
CAT NB2 / Band25	-116.2	-

Band	REFsens (dBm) Typical	3GPP REFsens (dBm)* 3GPP limit
CAT NB2 / Band26	-116.1	-108.2
CAT NB2 / Band28	-116.8	-108.2
CAT NB2 / Band66	-115.6	-108.2
CAT NB2 / Band71	-113.7	-
CAT NB2 / Band85	-116.0	-

Table 7: RX Sensitivity ME910G1-WW and ME910G1-WWV

* 3GPP TS 36.521-1 Release 15 Minimum performance requirement

2.7. Mechanical Specifications

2.7.1. Dimensions

The overall dimensions of ME910G1-W1, ME910G1-WW and ME910G1-WWV are:

- Length: 28.2 mm
- Width: 28.2 mm
- Thickness: 2.4 mm

2.7.2. Weight

The nominal weight of the ME910G1-W1 is 3.5 gr.

The nominal weight of the ME910G1-WW and ME910G1-WWV is 4 gr.

2.8. Temperature Range

Temperature Range		Note
Operating Temperature Range	-40°C to +85°C	The module is fully functional (*) and compliant according to regulatory standards.
Storage Temperature Range	-40°C to +105°C	The module is not powered and not connected to power supply

Table 8: Temperature Range



Note: (*) Functional: if applicable, the module is able to make and receive voice calls, data calls, send and receive SMS and data traffic.

3. PINS ALLOCATION

3.1. Pin-out

Pin	Signal	I/O	Function	Type	Comment
USB HS 2.0 COMMUNICATION PORT (FW upgrade and Data)					
B15	USB_D+	I/O	USB differential Data (+)		
C15	USB_D-	I/O	USB differential Data (-)		
A13	VUSB	I	Enable pin for the internal USB transceiver.	5 / 3V	Internal PD (100K)
Asynchronous Serial Port (USIF0) (FW upgrade and Data with Flow Control)					
N15	C103/TXD	I	Serial data input from DTE	CMOS 1.8V	internal PU (100k)
M15	C104/RXD	O	Serial data output to DTE	CMOS 1.8V	
M14	C108/DTR	I	Input for (DTR) from DTE	CMOS 1.8V	internal PU (100k)
L14	C105/RTS	I	Input for Request to send signal (RTS) from DTE	CMOS 1.8V	internal PU (100k)
P15	C106/CTS	O	Output for Clear to Send signal (CTS) to DTE	CMOS 1.8V	
N14	C109/DCD	O	Output for (DCD) to DTE	CMOS 1.8V	
P14	C107/DSR	O	Output for (DSR) to DTE	CMOS 1.8V	
R14	C125/RING	O	Output for Ring (RI) to DTE	CMOS 1.8V	
SIM Card Interface					
A6	SIMCLK	O	External SIM signal – Clock	1.8V	
A7	SIMRST	O	External SIM signal – Reset	1.8V	
A5	SIMIO	I/O	External SIM signal – Data I/O	1.8V	
A4	SIMIN	I	External SIM signal – Presence (active low)	CMOS 1.8	Internal PU (470K)
A3	SIMVCC	-	External SIM signal – Power supply for the SIM	1.8V	
Digital Voice Interface (DVI)					
B9	DVI_WA0	I/O	Digital Audio Interface (WA0)	1.8V	

Pin	Signal	I/O	Function	Type	Comment
B6	DVI_RX	I	Digital Audio Interface (RX)	1.8V	
B7	DVI_TX	I/O	Digital Audio Interface (TX)	1.8V	
B8	DVI_CLK	I/O	Digital Audio Interface (CLK)	1.8V	
SPI					
D15	SPI_MOSI	I/O	SPI MOSI	CMOS 1.8V	
E15	SPI_MISO	I/O	SPI_MISO	CMOS 1.8V	
F15	SPI_CLK	I/O	SPI Clock	CMOS 1.8V	
H14	SPI_CS	I/O	SPI Chip Select	CMOS 1.8V	
DIGITAL IO					
C8	GPIO_01	I/O	GPIO_01 /STAT LED	CMOS 1.8V	STAT LED is alternate function internal PD (100K)
C9	GPIO_02	I/O	GPIO_02	CMOS 1.8V	internal PD (100K)
C10	GPIO_03	I/O	GPIO_03	CMOS 1.8V	internal PD (100K)
C11	GPIO_04	I/O	GPIO_04	CMOS 1.8V	internal PD (100K)
B14	GPIO_05	I/O	GPIO_05	CMOS 1.8V	internal PD (100K)
C12	GPIO_06	I/O	GPIO_06	CMOS 1.8V	internal PD (100K)
C13	GPIO_07	I/O	GPIO_07	CMOS 1.8V	internal PD (100K)
K15	GPIO_08	I/O	GPIO_08	CMOS 1.8V	internal PD (100K)
L15	GPIO_09	I/O	GPIO_09	CMOS 1.8V	internal PD (100K)
G15	GPIO_10	I/O	GPIO_10	CMOS 1.8V	internal PD (100K)
ADC					
B1	ADC_IN	AI	Analog Digital Converter input		
RF SECTION					

Pin	Signal	I/O	Function	Type	Comment
K1	ANTENNA	I/O	LTE Antenna (50 ohm)	RF	
GNSS Section					
R9	ANT_GNSS	I	GNSS Antenna (50 ohm)	RF	
R7	GNSS_LNA_EN	O	External GNSS LNA Enable	CMOS 1.8V	
Miscellaneous Functions					
R13	HW_SHUTDOWN*	I	HW Unconditional Shutdown	VBATT	Active low
R12	ON_OFF*/WAKE*	I	Input command for power ON and to wake from deep sleep mode	1.8V	Active low
R11	VAUX/PWRMON	O	Supply Output for external accessories / Power ON Monitor	1.8V	
F14	FORCED_USB_BOOT	I	Debug pin, connect to test point	CMOS 1.8V	Active high, internal PD (100K)
Power Supply					
M1	VBATT	-	Main power supply (Baseband)	Power	
M2	VBATT	-	Main power supply (Baseband)	Power	
N1	VBATT_PA	-	Main power supply (Radio PA)	Power	
N2	VBATT_PA	-	Main power supply (Radio PA)	Power	
P1	VBATT_PA	-	Main power supply (Radio PA)	Power	
P2	VBATT_PA	-	Main power supply (Radio PA)	Power	
E1	GND	-	Ground	Power	
G1	GND	-	Ground	Power	
H1	GND	-	Ground	Power	
J1	GND	-	Ground	Power	
L1	GND	-	Ground	Power	
A2	GND	-	Ground	Power	
E2	GND	-	Ground	Power	
F2	GND	-	Ground	Power	
G2	GND	-	Ground	Power	
H2	GND	-	Ground	Power	
J2	GND	-	Ground	Power	

Pin	Signal	I/O	Function	Type	Comment
K2	GND	-	Ground	Power	
L2	GND	-	Ground	Power	
R2	GND	-	Ground	Power	
M3	GND	-	Ground	Power	
N3	GND	-	Ground	Power	
P3	GND	-	Ground	Power	
R3	GND	-	Ground	Power	
D4	GND	-	Ground	Power	
M4	GND	-	Ground	Power	
N4	GND	-	Ground	Power	
P4	GND	-	Ground	Power	
R4	GND	-	Ground	Power	
N5	GND	-	Ground	Power	
P5	GND	-	Ground	Power	
R5	GND	-	Ground	Power	
N6	GND	-	Ground	Power	
P6	GND	-	Ground	Power	
R6	GND	-	Ground	Power	
P8	GND	-	Ground	Power	
R8	GND	-	Ground	Power	
P9	GND	-	Ground	Power	
P10	GND	-	Ground	Power	
R10	GND	-	Ground	Power	
M12	GND	-	Ground	Power	
B13	GND	-	Ground	Power	
P13	GND	-	Ground	Power	
E14	GND	-	Ground	Power	
RESERVED					
C1	RESERVED	-	RESERVED		
D1	RESERVED	-	RESERVED		
F1	RESERVED	-	RESERVED		

Pin	Signal	I/O	Function	Type	Comment
B2	RESERVED	-	RESERVED		
C2	RESERVED	-	RESERVED		
D2	RESERVED	-	RESERVED		
B3	RESERVED	-	RESERVED		
C3	RESERVED	-	RESERVED		
D3	RESERVED	-	RESERVED		
E3	RESERVED	-	RESERVED		
F3	RESERVED	-	RESERVED		
G3	RESERVED	-	RESERVED		
K3	RESERVED	-	RESERVED		
L3	RESERVED	-	RESERVED		
B4	RESERVED	-	RESERVED		
C4	RESERVED	-	RESERVED		
B5	RESERVED	-	RESERVED		
C5	RESERVED	-	RESERVED		
C6	RESERVED	-	RESERVED		
C7	RESERVED	-	RESERVED		
N7	RESERVED	-	RESERVED		
P7	RESERVED	-	RESERVED		
N8	RESERVED	-	RESERVED		
N9	RESERVED	-	RESERVED		
A10	RESERVED	-	RESERVED		
N10	RESERVED	-	RESERVED		
N11	RESERVED	-	RESERVED		
P11	RESERVED	-	RESERVED		
B12	RESERVED	-	RESERVED		
D12	RESERVED	-	RESERVED		
N12	RESERVED	-	RESERVED		
P12	RESERVED	-	RESERVED		
G14	RESERVED	-	RESERVED		
J14	RESERVED	-	RESERVED		

Pin	Signal	I/O	Function	Type	Comment
K14	RESERVED	-	RESERVED		
N13	RESERVED	-	RESERVED		
L13	RESERVED	-	RESERVED		
J13	RESERVED	-	RESERVED		
M13	RESERVED	-	RESERVED		
K13	RESERVED	-	RESERVED		
H13	RESERVED	-	RESERVED		
G13	RESERVED	-	RESERVED		
F13	RESERVED	-	RESERVED		
B11	RESERVED	-	RESERVED		
B10	RESERVED	-	RESERVED		
A9	RESERVED	-	RESERVED		
A8	RESERVED	-	RESERVED		
E13	RESERVED	-	RESERVED		
D13	RESERVED	-	RESERVED		
D14	RESERVED	-	RESERVED		
A14	RESERVED	-	RESERVED		
A12	RESERVED	-	RESERVED		
A11	RESERVED	-	RESERVED		
H15	RESERVED	-	RESERVED		
J15	RESERVED	-	RESERVED		
C14	RESERVED	-	RESERVED		
H3	RESERVED	-	RESERVED		
J3	RESERVED	-	RESERVED		

Table 9: Pin-out Information

Warning: Reserved pins must not be connected.











Only D13-E13 pins can be connected together in order to be compatible with HE910 module. All pull-up (PU) and pull-down (PD) are about 100K

3.2. LGA Pads Layout

TOP VIEW

	1	2	3	4	5	6	7	8	9	10	11	12	13	14	15	16	17	18	19	
A	HW_KEY		GND		CELL_MAIN		GND		WIFI		GND		BT		GND		GND			A
B		GND		GND		GND		GND		GND		GND		GND		GND		RES		B
C	EAR+																		GND	C
D		RES					IO3		IO4		IO5		IO6					RES		D
E	EAR-			HID1												HID2			GNSS	E
F		RES					GND				GND							RES		F
G	MIC+			GND												GNSS_LNA			GND	G
H		TX_AUX				GND								GND				RES		H
J	MIC-			SD_D3												GNSS_ON			CELL_DIV	J
K		RX_AUX																USB_BOOT		K
L	SIM_CLK			SD_D2												GNSS_PPS			GND	L
M		GND																WAKE		M
N	SIM_IO			SD_D1												ALM			ON_OFF	N
P		SD_CLK				GND								GND				PSM		P
R	SIM_RST			SD_D0												S_LED			RST	R
T		SD_CS					GND				GND							USB_VBUS		T
U	SIM_VCC			HID3												HID4			USB_D+	U
V		POW_GND					IO1		IO2		ADC		DAC						GND	V
W	VBATT/VBATT_PA																		USB_D-	W
Y		VBATT/VBATT_PA		POW_GND		CS		MISO		CTS1		RTS1		V_AUX		CTS0		RTS0		Y
AA			VBATT/VBATT_PA		POW_GND		CLK		MOSI		RXD1		TXD1		RXD0		TXD0			AA

Figure 1: LGA Pads Layout

	SUPPLY AND CONTROL		DIGITAL COMMUNICATION
	SIM CARD		RF SIGNALS
	ANALOG FUNCTIONALITY		RESERVED/NOT ASSIGNED/ RESERVED FOR FUTURE USE
	GROUND		GNSS
	DIGITAL FUNCTIONALITY		

4. POWER SUPPLY

The power supply circuitry and the board layout are a very important part in the full product design and they strongly reflect on the product overall performances, so the requirements and the guidelines that will follow should be read carefully for a proper design.

4.1. Power Supply Requirements

The external power supply must be connected to VBATT and VBATT_PA pads and must fulfil the following requirements:

Power Supply	Value
Nominal Supply Voltage	3.8V
Operating Voltage Range	3.2 V - 4.2 V
Extended Voltage Range	2.6 V - 4.5 V
VBATT _{min}	2.7V

Table 10: Power Supply Requirements



Warning: The range 2.6V - 3.2V can be used only if both USB and 2G are disabled.



Warning: The supply voltage of the modem must never exceed the Extended Operating Voltage Range.
Wrong implementation of power supply guidelines described in this document may result in module fault.



Note: For PTCRB approval on the final products the power supply is required to be within the “Normal Operating Voltage Range”.

Note: The application's power supply section must be designed with care to avoid an excessive voltage drop during transmission peak current absorptions. If the voltage drops beyond the limits of the Extended Operating Voltage range, an unintentional module power off can occur.



Note: When turning on the modem, the voltage must be at least VBATTmin.

Note: HW User Guide specifications shall be fully acknowledged and correctly implemented in order to use the module in its "Extended Operating Voltage Range".

4.2. Power Consumption

4.2.1. Idle mode

Mode	Measure (Typical)			Mode Description
IDLE mode	CATM (mA)	NB-IoT (mA)	2G (mA)	
AT+CFUN=1	9.5	9.2	9.0	Normal mode: full functionality of the module
AT+CFUN=4	7.5			Disabled TX and RX; module is not registered on the network
AT+CFUN=5	1.20	0.95	-	Paging cycle #256 frames (2.56s DRx cycle)
	0.60	0.60	-	81.92s eDRx cycle length (PTW=2.56s, DRX=1.28s)
	0.18 ¹	0.18 ¹	-	327.68s eDRx cycle length (PTW=2.56s, DRX=1.28s)
	0.10 ¹	0.10 ¹	-	655.36s eDRx cycle length (PTW=2.56s, DRX=1.28s)
	0.05 ¹	0.05 ¹	-	1310.72s eDRx cycle length (PTW=2.56s, DRX=1.28s)
	0.03 ¹	0.03 ¹	-	2621.44s eDRx cycle length (PTW=2.56s, DRX=1.28s)
	-	-	0.90	Paging Multiframe 9
PSM mode	Typical (mA)			
AT+CPSMS=1	3uA			No current source or sink by any connected pin

Table 11: Idle and PSM Mode

¹PSM in between eDRX

Mode		Measure* (Typical)		Mode Description
GPS		(mA)		
Active State (GNSS ON, CFUN=4)	Acquisition	69.3	GPS+GLO, DPO off	
	Navigation	22	GPS+GLO, DPO on DWELL=280ms	
		55.9	GPS+GLO, DPO off	
Active State (GNSS ON, CFUN=5 eDRX)	Acquisition	68.5	GPS+GLO, DPO off	
	Navigation	15.7	GPS+GLO, DPO on DWELL=280ms	
		54	GPS+GLO, DPO off	

Table 12:GPS Mode

*reference signal @-130 dbm with static scenario

Note: The reported LTE CAT M1 and LTE CAT NB1 values are an average among all the product variants and bands for each network wireless technology.



The support of specific network wireless technology depends on the product variant configuration.

4.2.2. ME910G1-W1 Connected Mode

Mode	Measure (Typical)		Mode Description
	Average (mA)	Peak (mA)	
Connected mode			
CATM	180	400	1 RB, RMC, TBS=5, QPSK, 21dBm, all bands
NBloT	245	340	3.75KHz, 1 SC, RU 32ms, TBS=0, BPSK, 20dBm, all bands
	65	290	15KHz, 12 SC, RU 1ms, TBS=5, QPSK, 21dBm, all bands

Table 13: ME910G1-W1 Connected Mode

4.2.3. ME910G1-WW and ME910G1-WWV Connected Mode

Mode	Measure (Typical)		Mode Description
	Average (mA)	Peak (mA)	
Connected mode			
CATM	380	1100	1 RB, RMC, TBS=5, QPSK, 23dBm, Band 85, 28, 12
	320	900	1 RB, RMC, TBS=5, QPSK, 23dBm, Band 13, 26, 5, 18, 19, 20, 8
	305	800	1 RB, RMC, TBS=5, QPSK, 23dBm, Band 3, 2, 25, 4, 1, 66
NBloT	240	335	3.75KHz, 1 SC, RU 32ms, TBS=0, BPSK, 20dBm, Band 71
	600	1000	3.75KHz, 1 SC, RU 32ms, TBS=0, BPSK, 23dBm, Band 85, 28, 12
	500	850	3.75KHz, 1 SC, RU 32ms, TBS=0, BPSK, 23dBm, Band 13, 26, 5, 18, 19, 20, 8
	430	750	3.75KHz, 1 SC, RU 32ms, TBS=0, BPSK, 23dBm, Band 3, 2, 25, 4, 1, 66
	68	300	15KHz, 12 SC, RU 1ms, TBS=5, QPSK, 21dBm, Band 71
	88	950	15KHz, 12 SC, RU 1ms, TBS=5, QPSK, 23dBm, Band 85, 28, 12
	78	800	15KHz, 12 SC, RU 1ms, TBS=5, QPSK, 23dBm, Band 13, 26, 5, 18, 19, 20, 8
	77	730	15KHz, 12 SC, RU 1ms, TBS=5, QPSK, 23dBm, Band 3, 2, 25, 4, 1, 66
GPRS	300	2000	1TX + 1RX, CS1, GMSK, Band 850, 900
	170	1000	1TX + 1RX, CS1, GMSK, Band 1800, 1900

Table 14: ME910G1-WW and ME910G1-WWV Connected Mode

4.3. General Design Rules

The main guidelines for the Power Supply Design include three different design steps:

- the electrical design of the power supply
- the thermal design
- the PCB layout

4.3.1. Electrical Design Guidelines of the power supply

The electrical design of the power supply strongly depends on the power source where this power is drained. We will distinguish them into three categories:

- +5V input (typically PC internal regulator output)
- +12V input (typically automotive)
- Battery

4.3.1.1. +5V Source Power Supply Design Guidelines

- The desired output for the power supply is 3.8V, so there's not a big difference between the input source and the desired output and a linear regulator can be used. A switching power supply will not be suited due to the low drop out requirements.
- When using a linear regulator, a proper heat sink shall be provided in order to dissipate the power generated.
- A Bypass low ESR capacitor of adequate capacity must be provided in order to cut the current absorption peaks close to the Module, a 100 μ F capacitor is usually suitable.
- Make sure the low ESR capacitor on the power supply output rated at least 10V.

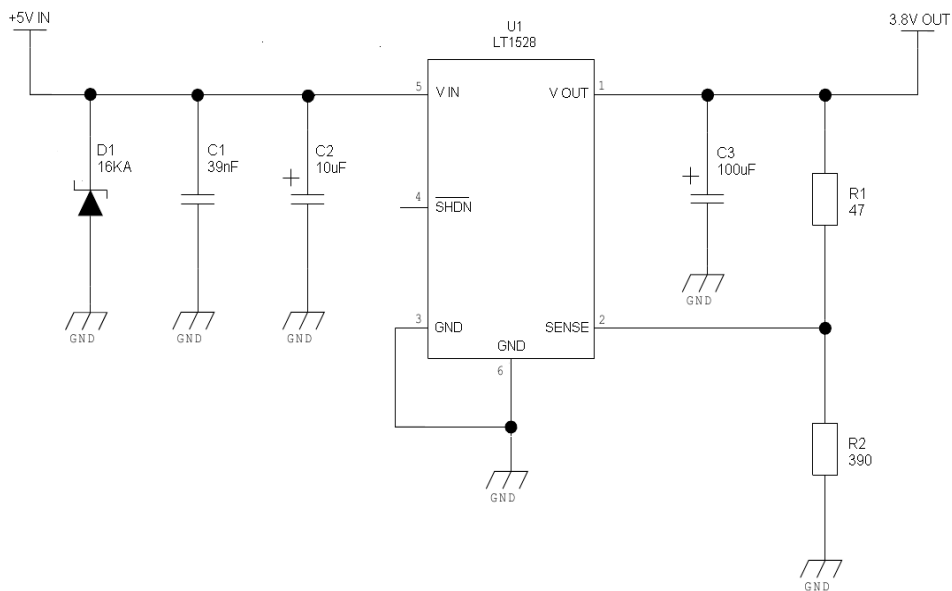

Figure 2: An example of linear regulator with 5V input

4.3.1.2. +12V Source Power Supply Design Guidelines

- The desired output for the power supply is 3.8V, so due to the big difference between the input source and the desired output, a linear regulator is not suitable and shall not be used. A switching power supply will be preferable because of its better efficiency.
- When using a switching regulator, a 500kHz or more switching frequency regulator is preferable because of its smaller inductor size and its faster transient response. This allows the regulator to respond quickly to the current peaks absorption.
- In any case the frequency and Switching design selection is related to the application to be developed since the switching frequency could also generate EMC interferences.
- For car PB battery the input voltage can rise up to 15,8V and this should be kept in mind when choosing components: all components in the power supply must withstand this voltage.
- A Bypass low ESR capacitor of adequate capacity must be provided in order to cut the current absorption peaks, a 100 μ F capacitor is usually suitable.
- Make sure the low ESR capacitor on the power supply output is rated at least 10V.
- For Car applications a spike protection diode should be inserted close to the power input, in order to clean the supply from the spikes.

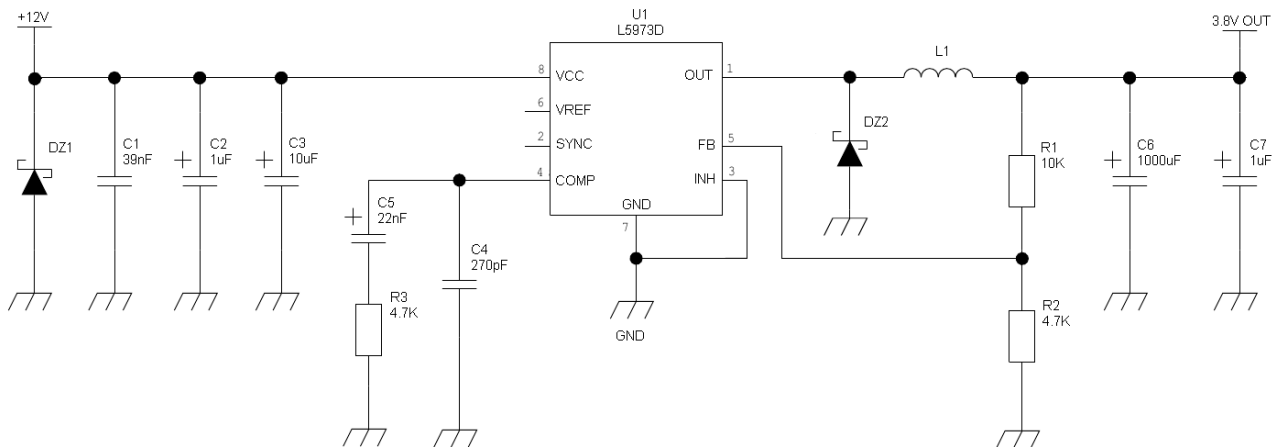

Figure 3: An example of switching regulator with 12V input

4.3.1.3. Battery Source Power Supply Design Guidelines

The desired nominal output for the power supply is 3.8V and the maximum voltage allowed is 4.2V, hence a single 3.7V Li-Ion cell battery type is suited for supplying the power to the Telit ME910G1 module.

- A Bypass low ESR capacitor of adequate capacity must be provided in order to cut the current absorption peaks, a 100 μ F tantalum capacitor is usually suited.
- Make sure the low ESR capacitor (usually a tantalum one) is rated at least 10V.
- A protection diode should be inserted close to the power input, in order to save the ME910G1 from power polarity inversion. Otherwise the battery connector should be done in a way to avoid polarity inversions when connecting the battery.
- The battery must be rated to supply peaks of current up to 0.6 A for LTE.



Note: DON'T USE any Ni-Cd, Ni-MH, and Pb battery types directly connected with ME910G1. Their use can lead to overvoltage on the ME910G1 and damage it. You can use LI-Ion, Li-PO₄, Li-FePO₄ secondary batteries or hi current Lithium primary batteries.

4.3.2. Thermal Design Guidelines

Worst case as reference values for thermal design of ME910G1 are:

- Average current consumption: 700 mA (LTE CAT M1 and NB1 modes)
- Average current consumption: 700 mA (GPRS and EDGE modes)
- Supply voltage: 4.50V



Note: Make PCB design in order to have the best connection of GND pads to large surfaces of copper.



Note: The ME910G1 includes a function to prevent overheating.

4.3.3. Power Supply PCB layout Guidelines

As seen on the guidelines for electrical design, the power supply shall have a low ESR capacitor on the output to cut the current peaks on the input to protect the supply from spikes. The placement of this component is crucial for the correct working of the circuitry. A misplaced component can be useless or can even decrease the power supply performances.

- The Bypass low ESR capacitor must be placed close to the Telit ME910G1 power input pads or, in the case the power supply is a switching type it can be placed close to the inductor to cut the ripple provided the PCB trace from the capacitor to the ME910G1 is wide enough to ensure a voltage dropless connection even during an 0.6 A (LTE) or 2A (GSM) current peak.
- The protection diode must be placed close to the input connector where the power source is drained.
- The PCB's traces from the input connector to the power regulator IC must be wide enough to ensure no voltage drops occur when an 2 A current peak is absorbed (valid only for product supporting GSM mode).
- The PCB traces to the ME910G1 and the Bypass capacitor must be wide enough to ensure no significant voltage drops occur. This is for the same reason as previous point. Try to keep this trace as short as possible.
- To reduce the EMI due to switching, it is important to keep the mesh involved very small; therefore the input capacitor, the output diode (if not embodied in the IC) and the regulator shall form a very small loop. This is done in order to reduce the radiated field (noise) at the switching frequency (100-500 kHz usually).
- A dedicated ground for the Switching regulator separated by the common ground plane is suggested.
- The placement of the power supply on the board should be done in such a way to guarantee that the high current return paths in the ground plane are not

overlapped to any noise sensitive circuitry as the microphone amplifier/buffer or earphone amplifier.

- The power supply input cables should be kept separate from noise sensitive lines such as microphone/earphone cables.
- The insertion of EMI filter on VBATT pins is suggested in those designs where antenna is placed close to battery or supply lines. A ferrite bead like Murata BLM18EG101TN1 or Taiyo Yuden P/N FBMH1608HM101 can be used for this purpose.

The below figure shows the recommended circuit:

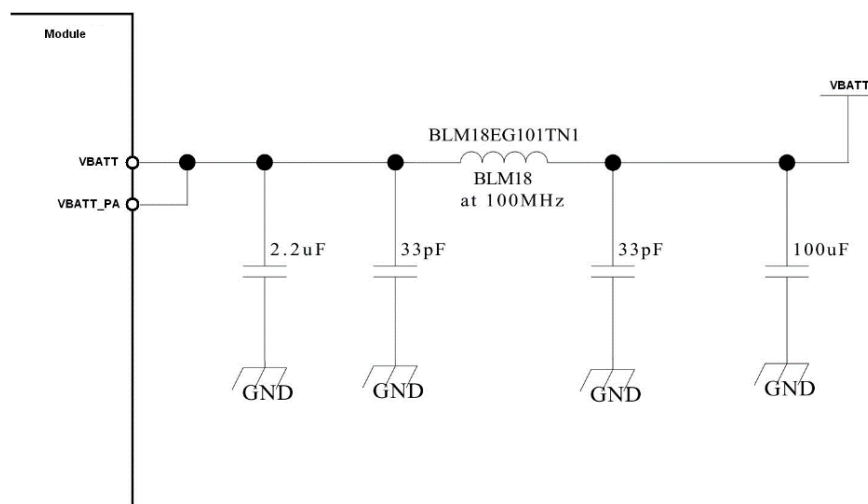

Figure 4: Recommended Circuit

4.4. VAUX Power Output

A regulated power supply output is provided to supply small devices from the module, like: level translators, audio codec, sensors, and others.

Pin R11 can be used also as PWRMON (module powered ON indication) function, because is always active when the module is powered ON and cannot be set to LOW level by any AT command.

Host can only detect deep sleep mode by monitoring of VAUX/PWRMON output pin, since there is no pin dedicated to PSM status indicator.

The operating range characteristics of the supply are:

Item	Min	Typical	Max
Output voltage	1.78V	1.80V	1.82V
Output current	-	-	60mA
Output bypass capacitor (inside the module)		1 μ F	

Table 15: Operating range characteristics of the supply



Note: If power saving configuration is enabled by AT+CPSMS Command, VAUX during deep sleep mode period is OFF

4.5. RTC Supply

RTC is functional when ME910G1 is in PSM or OFF state and VBATT pin is supplied.

RTC settings are erased if VBATT supply is temporary disconnected.

5. DIGITAL SECTION

ME910G1 has four main operation states:

- **OFF state:** Vbatt is applied and only RTC is running. Baseband is switched OFF and the only change possible is the ON state.
- **ON state:** baseband is fully switched on and ME910G1 is ready to accept AT commands. ME910G1 can be idle or connected.
- **Sleep mode state:** main baseband processor is intermittently switched ON and AT commands can be processed with some latency. ME910G1 is idle with low current consumption.
- **Deep sleep mode state:** PSM defined in 3GPP Release 12. Baseband is switched OFF most of the time.

5.1. Logic Levels

Parameter	Min	Max
ABSOLUTE MAXIMUM RATINGS – NOT FUNCTIONAL		
Input level on any digital pin (CMOS 1.8) with respect to ground	-0.3V	2.1V
Operating Range - Interface levels (1.8V CMOS)		
Input high level	1.5V	1.9V
Input low level	0V	0.35V
Output high level	1.6V	1.9V
Output low level	0V	0.2V

Table 16: Logic levels Minimum and maximum

Parameter	Max
Current characteristics:	
Output Current	1mA
Input Current	1uA

Table 17: Logic levels average

5.2. Power On

To turn on the ME910G1 the pad ON_OFF*/WAKE* must be tied low for at least 5 second and then released.

The maximum current that can be drained from the ON_OFF*/WAKE* pad is 0,1 mA.

ON_OFF*/WAKE* pad can make an asynchronous wakeup of the system from the PSM Mode, before the scheduled event of timer T3412 expired.

To make asynchronous exit from PSM mode ON_OFF*/WAKE* pin must be set LOW for at least 5 seconds.

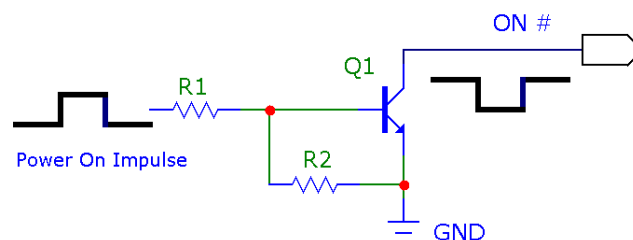

Figure 5: Power-on Circuit; illustrates a simple circuit to power on the module using an inverted buffer output.

Note: Do not use any pull up resistor on the ON_OFF*/WAKE* line, it is internally pulled up. Using pull up resistor may bring to latch up problems on the ME910G1 power regulator and improper power on/off of the module. The line ON_OFF*/WAKE* must be connected only in open collector or open drain configuration.



In this document all the lines that are inverted, hence have active low signals are labelled with a name that ends with "#", "*" or with a bar over the name.

To check if the device has powered on, the hardware line PWRMON should be monitored.

A flow chart showing the proper turn on procedure is displayed below:

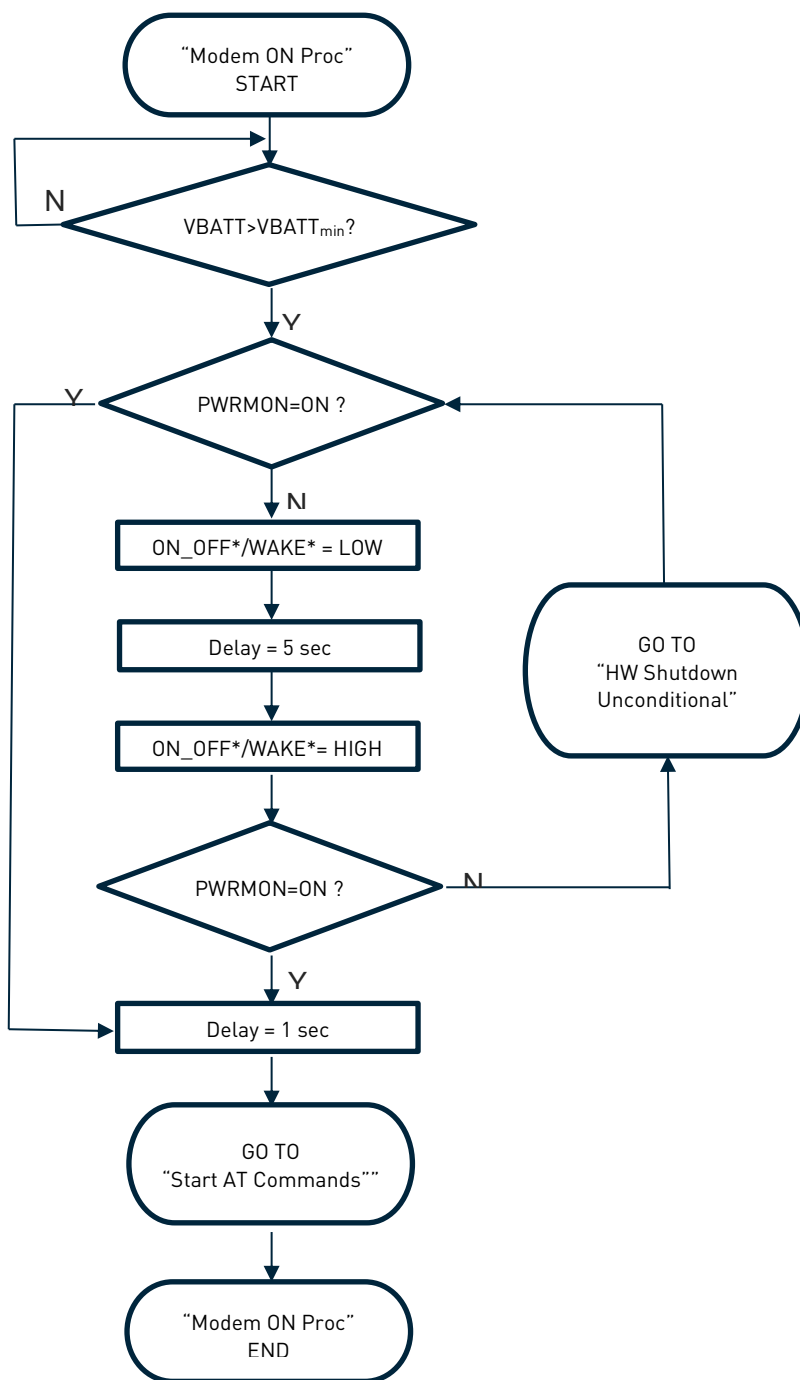

Figure 6: Turn on procedure flow chart

A flow chart showing the AT commands managing procedure is displayed below:

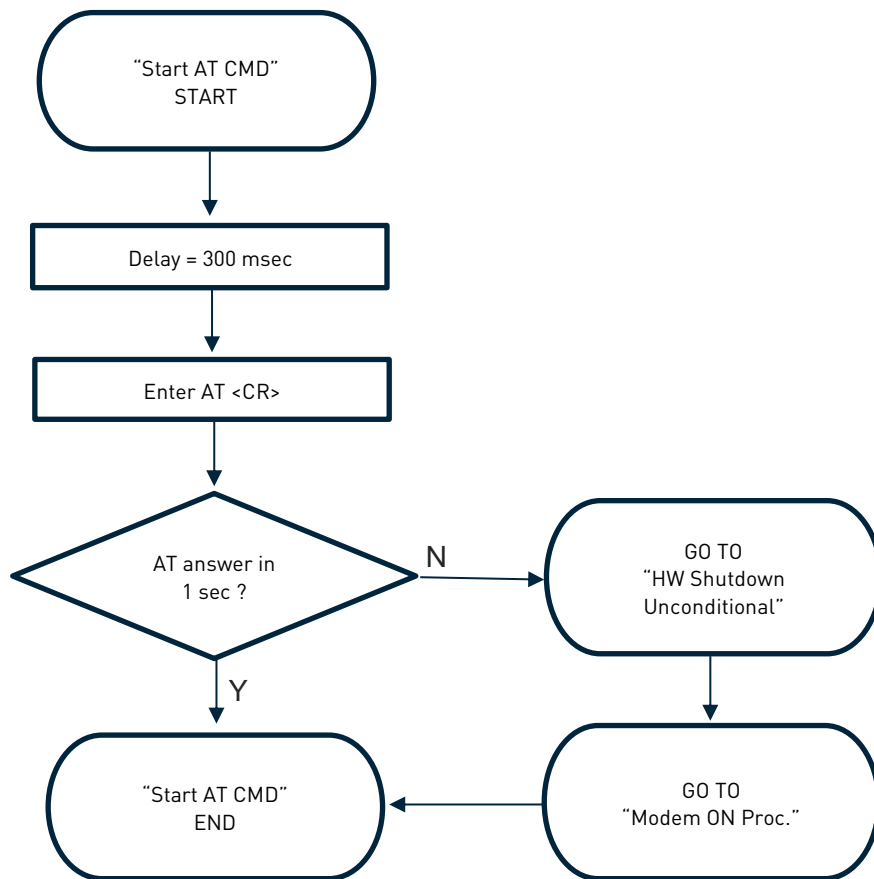

Figure 7: AT commands managing procedure flow chart



Note: In order to avoid a back powering it is recommended to prevent any HIGH logic level signal from being applied to the digital pins of the ME910G1 when the module is powered off or during an ON-OFF transition.

For example:

1- Let's assume you need to drive the ON_OFF*/WAKE* pad with a totem pole output of a +3/5 V microcontroller (uP_OUT1):

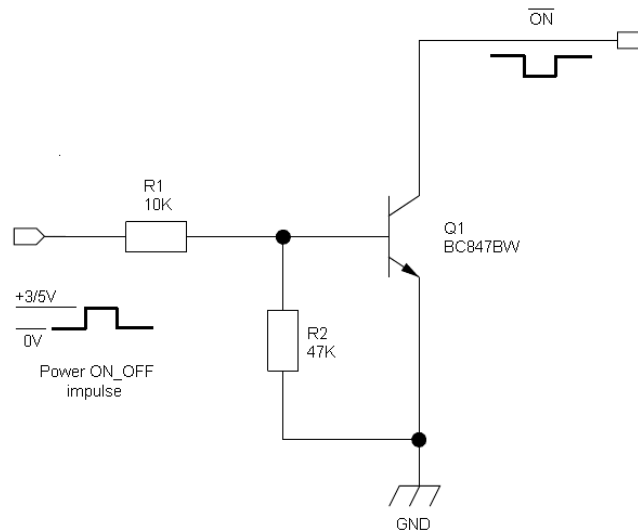

2- Let's assume you need to drive the ON_OFF*/WAKE* pad directly with an ON/OFF button:

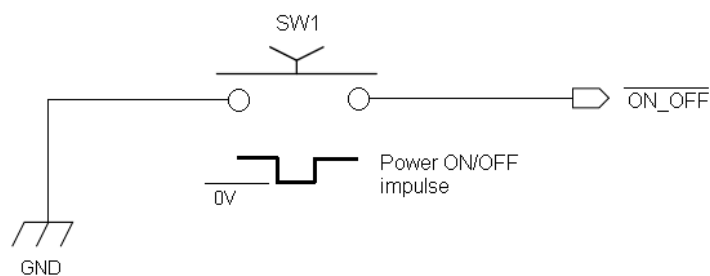

Warning: It is recommended to set the ON_OFF*/WAKE* line LOW to power on the module only after VBATT is higher than 3.20V. In case this condition is not satisfied you could use the HW_SHUTDOWN* line to recover it and then restart the power on activity using the ON_OFF*/WAKE* line. An example of this is described in the following diagram.

After HW_SHUTDOWN* is released you could again use the ON_OFF*/WAKE* line to power on the module.

5.3. Power Off

Turning off of the device can be done in two ways:

- via AT command (see ME910G1 Software User Guide, AT#SHDN)
- pin ON_OFF*/WAKE* for at least 3 seconds

Either ways, the device issues a detach request to network informing that the device will not be reachable any more.



Note: To check if the device has been powered off or IN PSM mode, the hardware line PWRMON must be monitored. The device is powered off when PWRMON goes low.

In order to avoid a back powering it is recommended to prevent any HIGH logic level signal from being applied to the digital pins of the ME910G1 when the module is powered off or during an ON-OFF transition.



Warning: Not following the recommended shut-down procedures might damage the device and consequently void the warranty.

The following flow chart shows the proper turn off procedure:

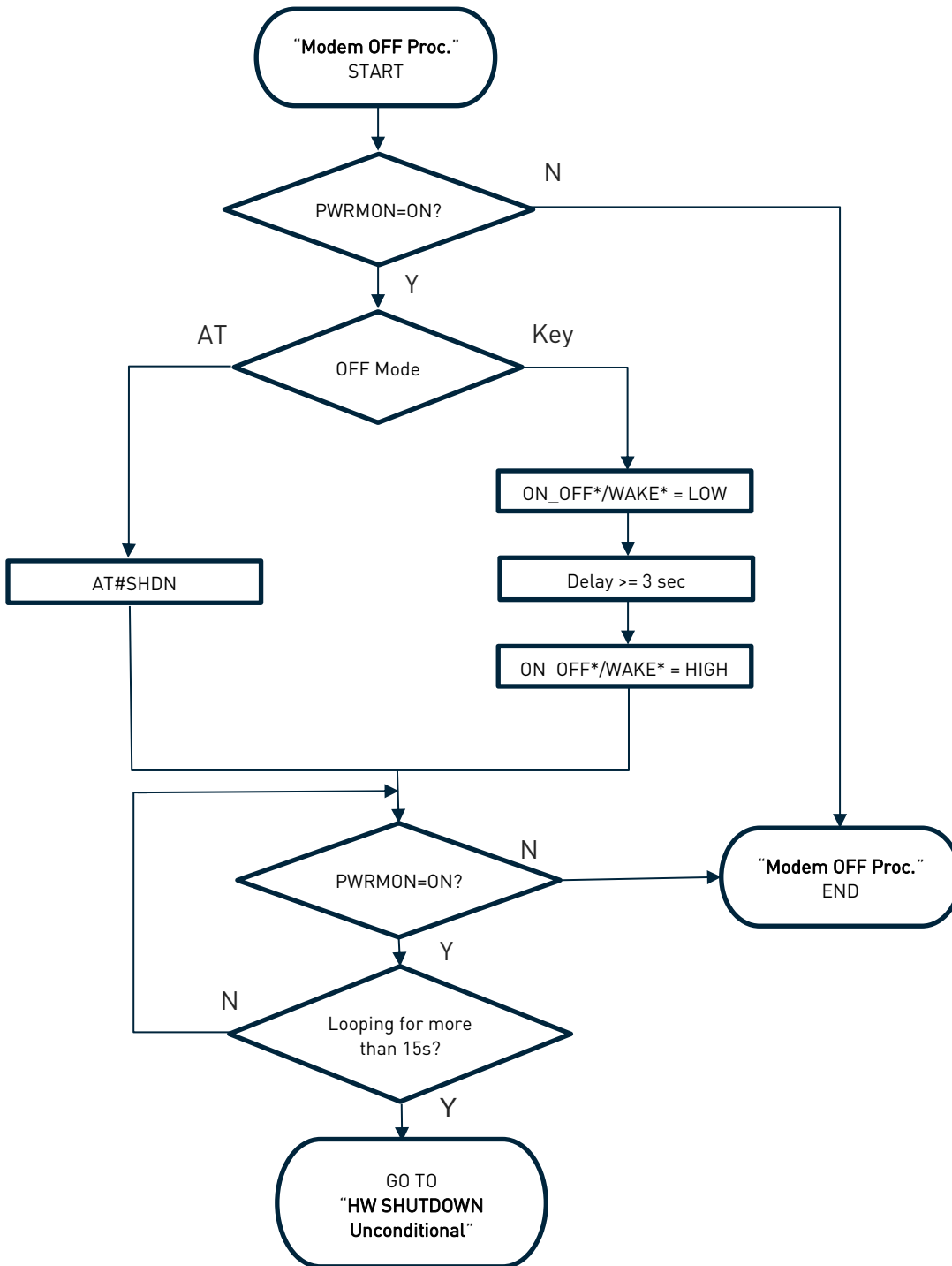

Figure 8: turn off procedure flow chart

5.4. Wake from deep sleep mode

ME910G1 supports Power Saving Mode (PSM) functionality defined in 3GPP Release 12. When Periodic Update Timer expires, ME910G1 power off until the next scheduled wake-up time.

Asynchronous event controlled by host can wake up from deep sleep mode by asserting ON_OFF*/WAKE* pin LOW for at least 5 seconds.

Host can detect deep sleep mode by polling VAUX/PWRMON pin if previously configured.

5.5. Unconditional Shutdown

HW_SHUTDOWN* is used to unconditionally shutdown the ME910G1. Whenever this signal is pulled low, the ME910G1 is reset. When the device is reset it stops any operation. After the release of the line, the ME910G1 is unconditionally shut down, without doing any detach operation from the network where it is registered. This behaviour is not a proper shut down because any cellular device is requested to issue a detach request on turn off. The HW_SHUTDOWN* is internally controlled on start-up to always achieve a proper power-on reset sequence, so there's no need to control this pin on start-up.

To unconditionally shutdown the ME910G1, the pad HW_SHUTDOWN* must be tied low for at least 200 milliseconds and then released.

The signal is internally pulled up so the pin can be left floating if not used.

If used, then it **must always be connected with an open collector transistor**, to permit to the internal circuitry the power on reset and under voltage lockout functions.

During PSM mode, HW_SHUTDOWN toggle has no effect. The use of HW_SHUTDOWN* pin is valid only when ME910G1 has VAUX/PWRMON output HI.

PIN DESCRIPTION

Signal	Function	I/O	PAD
HW_SHUTDOWN*	Unconditional Shutdown of the Module	I	R13

Table 18: HW_SHUTDOWN* signal



Warning: The hardware unconditional Shutdown must not be used during normal operation of the device since it does not detach the device from the network. It shall be kept as an emergency exit procedure.

A typical circuit is the following:

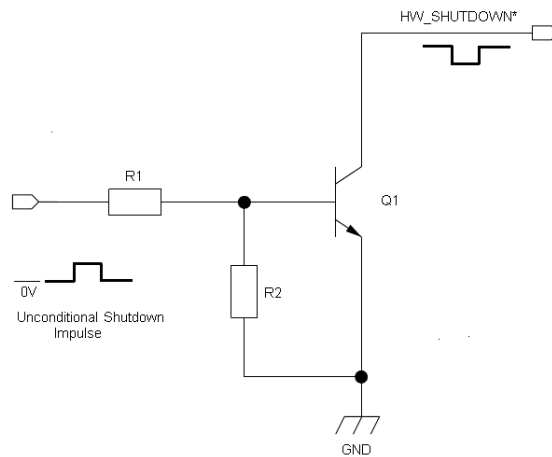

Figure 9: typical circuit

For example: Let us assume you need to drive the HW_SHUTDOWN* pad with a totem pole output of a +3/5 V microcontroller (uP_OUT2):

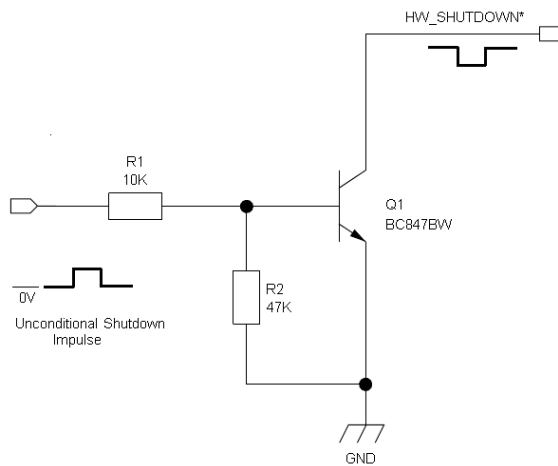

Figure 10: typical circuit

In the following flow chart the proper restart procedure is detailed:

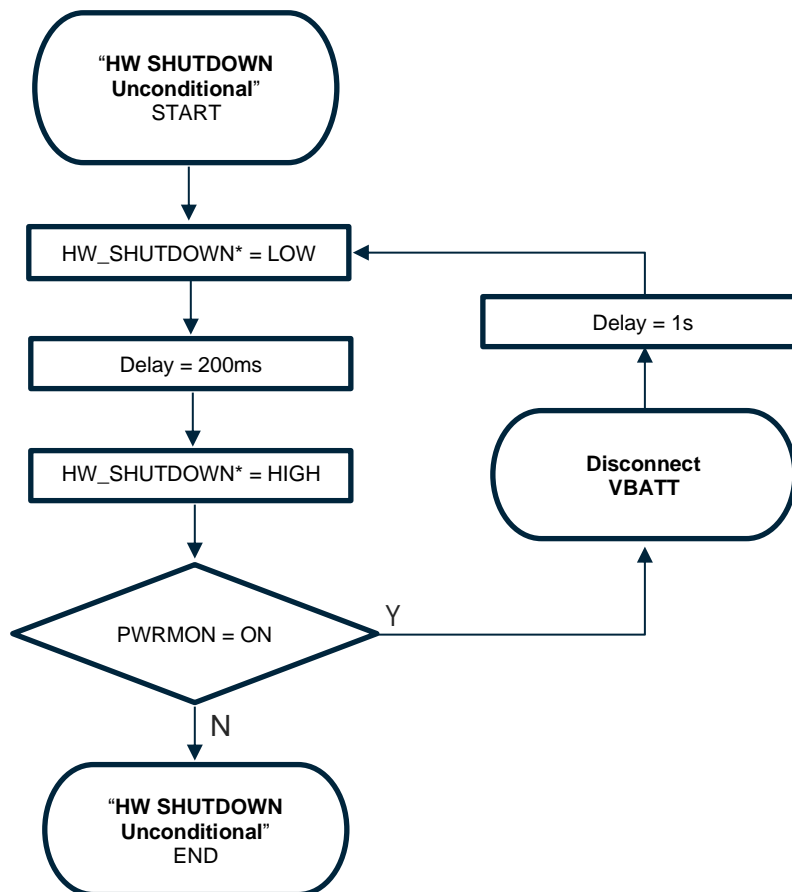

Figure 11: restart procedure flow chart



Note: In order to avoid a back powering it is recommended to prevent any HIGH logic level signal from being applied to the digital pins of the ME910G1 when the module is powered off or during an ON-OFF transition.

Note: Do not use any pull up resistor on the HW_SHUTDOWN* line nor any totem pole digital output. Using pull up resistor may bring to latch up problems on the ME910G1 power regulator and improper functioning of the module.



To proper power on again the module please refer to the related paragraph (“Power ON”)

The unconditional hardware shutdown must always be implemented on the boards and should be used only as an emergency exit procedure.

5.6. Fast shut down

The procedure to power off ME910G1 described in Chapter 5.3 normally takes more than 1 second to detach from the network and make ME910G1 internal filesystem properly closed.

In case of unwanted supply voltage loss the system can be switched off without any risk of filesystem data corruption by implementing Fast Shut Down feature.

Fast Shut Down feature permits to reduce the current consumption and the time-to-poweroff to minimum values.



Note: Refer to ME910G1 series AT command reference guide (Fast shut down - #FASTSHDN) in order to set up detailed AT command.

5.6.1. Fast Shut Down by Hardware

The fast shut down can be triggered by configuration of any GPIO. HI level to LOW level transition of GPIO commands fast shut down.

Example circuit:

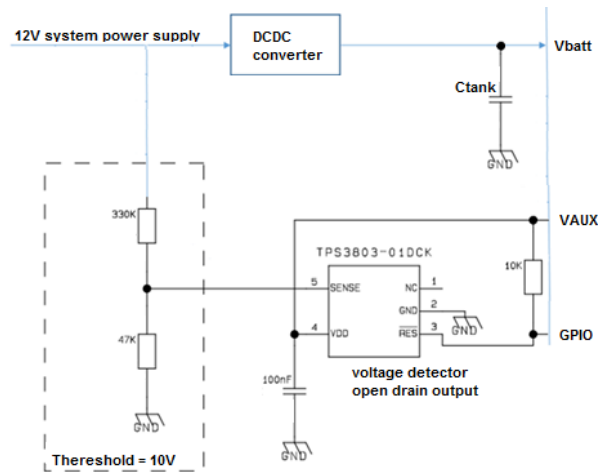

Figure 12: example circuit



Note: Consider voltage drop under max current conditions when defining the voltage detector threshold in order to avoid unwanted shutdown.

The capacitor is rated with the following formula:

$$C = I \frac{\Delta t}{\Delta V}$$



Tip: Make the same plot during system verification to check timings and voltage levels.

5.6.2. Fast Shut Down by Software

The fast shut down can be triggered by AT command.

5.7. Communication ports



Note: It is suggested to add PCB test points at non-used module's UART, UART_AUX and USB (for products that support USB), it can be useful to reflash, test and debug the application. Test points for UART or USB are fine, however we recommend placing the pads for a suitable connector to port, for convenient access for network certification testing and access during early development testing. The USB connector can be "DNP" until needed. This may be more convenient than just test points alone.

5.7.1. USB 2.0 HS

The ME910G1 includes one integrated universal serial bus (USB 2.0 HS) transceiver.

The following table lists the available signals:

PAD	Signal	I/O	Function	NOTE
B15	USB_D+	I/O	USB differential Data (+)	
C15	USB_D-	I/O	USB differential Data (-)	
A13	VUSB	AI	Power sense for the internal USB transceiver.	Accepted range: 3.0V to 5.5V 100K pull down

Table 19: Available Signals

The USB_DPLUS and USB_DMINUS signals have a clock rate of 480 MHz, therefore signal traces should be routed carefully. Trace lengths, number of vias and capacitive loading should be minimized. The characteristic impedance value should be as close as possible to 90 Ohms differential.

ESD protection can be added to USB D+/D- lines in case of external connector for cable connection.

Proper components for USB 2.0 must be used.

5.7.2. SPI

The ME910G1 Module is provided by a standard 3-wire master SPI interface + chip select control.

The following table lists the available signals:

PAD	Signal	I/O	Function	Type	NOTE
D15	SPI_MOSI	O	SPI MOSI	CMOS 1.8V	Shared with TX_AUX
E15	SPI_MISO	I	SPI MISO	CMOS 1.8V	Shared with RX_AUX
F15	SPI_CLK	O	SPI Clock	CMOS 1.8V	
H14	SPI_CS	O	SPI Chip Select	CMOS 1.8V	

Table 20: Available Signals



Note: Due to the shared functions, SPI port and TX_AUX/RX_AUX port cannot be used simultaneously.

Refer to ME910G1 series AT command reference guide for port configuration.

5.7.2.1. SPI Connections

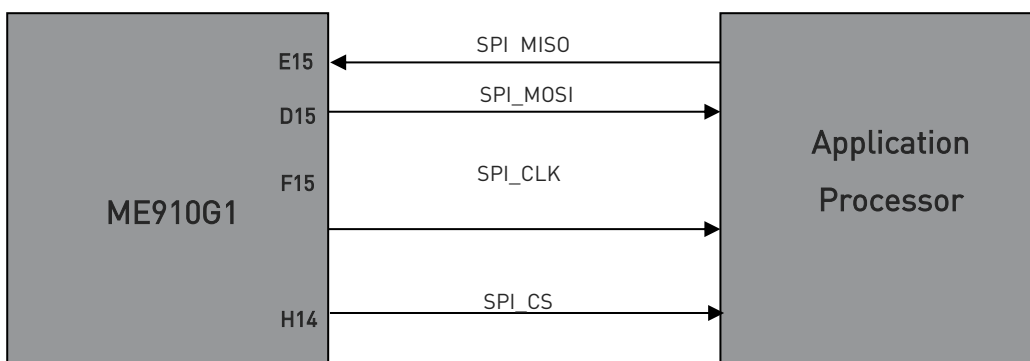

Figure 13: SPI Connections

5.7.3. Serial Ports

The ME910G1 module is provided with by 2 Asynchronous serial ports:

- MODEM SERIAL PORT 1 (Main)
- MODEM SERIAL PORT 2 (Auxiliary)

Several configurations can be designed for the serial port on the OEM hardware, but the most common are:

- RS232 PC com port
- microcontroller UART @ 1.8V (Universal Asynchronous Receive Transmit)
- microcontroller UART @ 5V or other voltages different from 1.8V

Depending on the type of serial port on the OEM hardware a level translator circuit may be needed to make the system work. On the ME910G1 the ports are CMOS 1.8.

5.7.3.1. Modem serial port 1 (USIF0)

The serial port 1 on the ME910G1 is a +1.8V UART with all the 7 RS232 signals. It differs from the PC-RS232 in the signal polarity (RS232 is reversed) and levels.

The following table is listing the available signals:

RS232 Pin	Signal	PAD	Name	Usage
1	C109/DCD	N14	Data Carrier Detect	Output from the ME910G1 that indicates the carrier presence
2	C104/RXD	M15	Transmit line *see Note	Output transmit line of ME910G1 UART
3	C103/TXD	N15	Receive line *see Note	Input receive of the ME910G1 UART
4	C108/DTR	M14	Data Terminal Ready	Input to the ME910G1 that controls the DTE READY condition
6	C107/DSR	P14	Data Set Ready	Output from the ME910G1 that indicates the module is ready
7	C105/RTS	L14	Request to Send	Input to the ME910G1 that controls the Hardware flow control
8	C106/CTS	P15	Clear to Send	Output from the ME910G1 that controls the Hardware flow control
9	C125/RING	R14	Ring Indicator	Output from the ME910G1 that indicates the incoming call condition

Table 21: Available Signals

Note: According to V.24, some signal names are referred to the application side, therefore on the ME910G1 side these signal are on the opposite direction: TXD on the application side will be connected to the receive line (here named C103/TXD)

RXD on the application side will be connected to the transmit line (here named C104/RXD).



For a minimum implementation, only the TXD, RXD lines can be connected, the other lines can be left open provided a software flow control is implemented.

In order to avoid a back powering it is recommended to prevent any HIGH logic level signal from being applied to the digital pins of the ME910G1 when the module is powered off or during an ON/OFF transition.

5.7.3.2. Modem serial port 2 (USIF1)

The auxiliary serial port on the ME910G1 is a CMOS1.8V with only the RX and TX signals.

The signals of the ME910G1 serial port are:

PAD	Signal	I/O	Function	Type	NOTE
D15	TX_AUX	O	Auxiliary UART (TX Data to DTE)	CMOS 1.8V	Shared with SPI_MOSI
E15	RX_AUX	I	Auxiliary UART (RX Data from DTE)	CMOS 1.8V	Shared with SPI_MISO

Table 22: ME910G1 serial port signals

Note: Due to the shared functions, TX_AUX/RX_AUX port and SPI port cannot be used simultaneously.



In order to avoid a back powering it is recommended to prevent any HIGH logic level signal from being applied to the digital pins of the ME910G1 when the module is powered off or during an ON/OFF transition.

Refer to ME910G1 series AT command reference guide for port configuration.

5.7.3.3. RS232 level translation

In order to interface the ME910G1 with a PC com port or a RS232 (EIA/TIA-232) application a level translator is required. This level translator must:

- invert the electrical signal in both directions;
- Change the level from 0/1.8V to +15/-15V.

Actually, the RS232 UART 16450, 16550, 16650 & 16750 chipsets accept signals with lower levels on the RS232 side (EIA/TIA-562), allowing a lower voltage-multiplying ratio on the level translator. Note that the negative signal voltage must be less than 0V and hence some sort of level translation is always required.

The simplest way to translate the levels and invert the signal is by using a single chip level translator. There are a multitude of them, differing in the number of drivers and receivers and in the levels (be sure to get a true RS232 level translator not a RS485 or other standards).

By convention the driver is the level translator from the 0-1.8V UART to the RS232 level. The receiver is the translator from the RS232 level to 0-1.8V UART.

In order to translate the whole set of control lines of the UART you will need:

- 5 drivers
- 3 receivers

An example of RS232 level adaptation circuitry could be done using a MAXIM transceiver (MAX218)

In this case the chipset is capable to translate directly from 1.8V to the RS232 levels (Example done on 4 signals only).

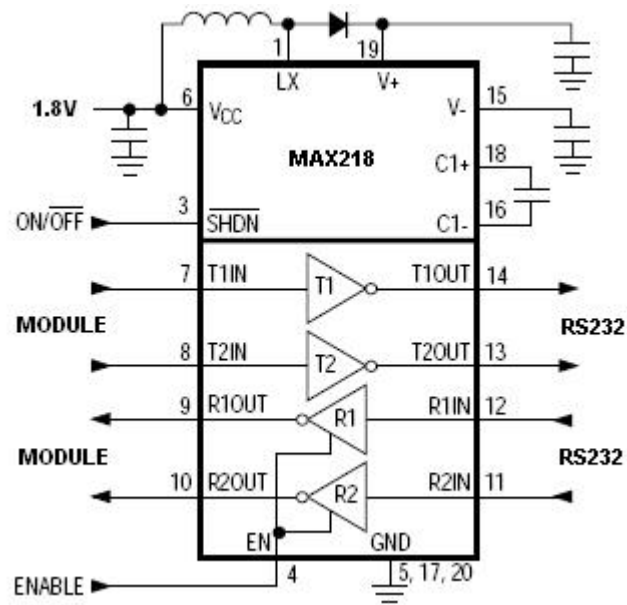

Figure 14: example circuitry

The RS232 serial port lines are usually connected to a DB9 connector with the following layout:

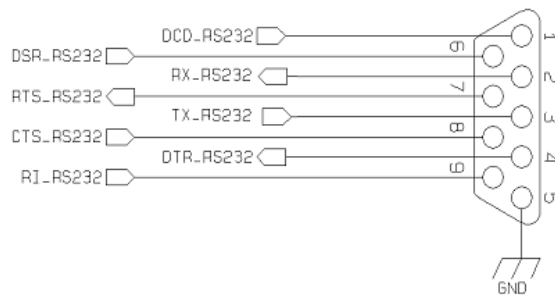

Figure 15: example RS232 serial port lines

5.8. General purpose I/O

The ME910G1 module is provided by a set of Configurable Digital Input / Output pins (CMOS 1.8V). Input pads can only be read; they report the digital value (high or low) present on the pad at the read time. The Output pads can only be written or queried and set the value of the pad output.

An alternate function pad is internally controlled by the ME910G1 firmware and acts depending on the function implemented.

The following table shows the available GPIO on the ME910G1:

PAD	Signal	I/O	Output Drive Strength	Default State	NOTE
C8	GPIO_01	I/O	1mA	INPUT – PD (100K)	Alternate function STAT LED
C9	GPIO_02	I/O	1mA	INPUT – PD (100K)	
C10	GPIO_03	I/O	1mA	INPUT – PD (100K)	
C11	GPIO_04	I/O	1mA	INPUT – PD (100K)	
B14	GPIO_05	I/O	1mA	INPUT – PD (100K)	
C12	GPIO_06	I/O	1mA	INPUT – PD (100K)	
C13	GPIO_07	I/O	1mA	INPUT – PD (100K)	(*)
K15	GPIO_08	I/O	1mA	INPUT – PD (100K)	
L15	GPIO_09	I/O	1mA	INPUT – PD (100K)	
G15	GPIO_10	I/O	1mA	INPUT – PD (100K)	

Table 23: ME910G1 available GPIO

5.8.1. Using a GPIO as INPUT

The GPIO pads, when used as inputs, can be connected to another device's digital output and report its status, provided this device has interface levels compatible with the 1.8V CMOS levels of the GPIO.

If the digital output of the device to be connected with the GPIO input pad of ME910G1 has interface levels different from the 1.8V CMOS, then it can be buffered with an open collector transistor with a 47K pull up to 1.8V supplied by VAUX/POWERMON R11 pad.



Note: In order to avoid a back powering it is recommended to prevent any HIGH logic level signal from being applied to the digital pins of the ME910G1 when the module is powered off or during an ON/OFF transition. Refer to ME910G1 series AT command reference guide for GPIO pins configuration.

5.8.2. Using a GPIO as OUTPUT

The GPIO pads, when used as outputs, can drive 1.8V CMOS digital devices or compatible hardware. When set as outputs, the pads have a push-pull output and therefore the pull-up resistor may be omitted.

5.8.3. Indication of network service availability

The STAT_LED pin status shows information on the network service availability and Call status. The function is available as alternate function of GPIO_01 (to be enabled using the AT#GPIO=1,0,2 command).

In the ME910G1 modules, the STAT_LED needs an external transistor to drive an external LED and its voltage level is defined accordingly to the table below:

Device Status	Led Status
Device off	Permanently off
Not Registered	Permanently on
Registered in idle	Blinking 1sec on + 2 sec off
Registered in idle + power saving	It depends on the event that triggers the wakeup (In sync with network paging)
Connecting	Blinking 1 sec on + 2 sec off

Table 24: LED and its status

In the following reference schematic for LED indicator, R3 must be calculated taking in account VBATT value and LED type:

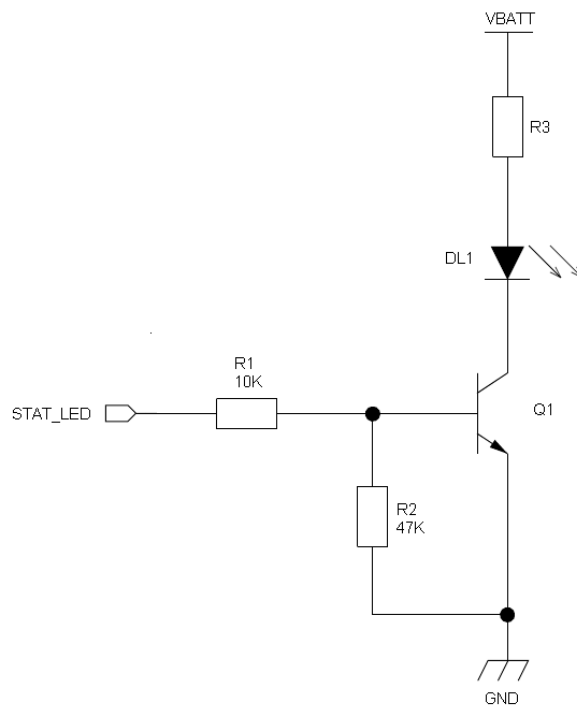

Figure 16: LED indicator reference schematic

5.9. External SIM Holder

Please refer to the related User Guide (SIM Holder Design Guides, 80000NT10001a).

5.10. ADC Converter

The ME910G1 is provided by one AD converter. It is able to read a voltage level in the range of 0÷1.8 volts applied on the ADC pin input, store and convert it into 10 bit word.

The input line is named as **ADC_IN1** and it is available on Pad **B1**

The following table is showing the ADC characteristics:

Item	Min	Typical	Max	Unit
Input Voltage range	0	-	1.8	Volt
AD conversion	-	-	10	bits
Input Resistance	1	-	-	Mohm
Input Capacitance	-	1	-	pF

Table 25: ADC characteristics

The ADC could be controlled using an AT command.

The command is ***AT#ADC=1,2***

The read value is expressed in mV

Refer to SW User Guide or AT Commands Reference Guide for the full description of this function.

6. RF SECTION

6.1. Antenna requirements

The antenna connection and board layout design are the most important aspect in the full product design as they strongly affect the general performance of the product, so read carefully and follow the requirements and the guidelines for a proper design.

The antenna and antenna transmission line on PCB for a Telit ME910G1 device shall fulfil the following requirements:

Item	Value
Frequency range	Depending by frequency band(s) provided by the network operator, the customer shall use the most suitable antenna for that/those band(s)
Bandwidth	250 MHz in LTE Band 1 140 MHz in LTE Band 2, PCS1900 170 MHz in LTE Band 3, DCS1800 445 MHz in LTE Band 4 70 MHz in LTE Band 5, GSM850 80 MHz in LTE Band 8, GSM900 47 MHz in LTE Band 12 41 MHz in LTE Band 13 60 MHz in LTE Band 18 60 MHz in LTE Band 19 71 MHz in LTE Band 20 145 MHz in LTE Band 25 80 MHz in LTE Band 26 62 MHz in LTE Band 27 100 MHz in LTE Band 28 490 MHz in LTE Band 66 81 MHz in LTE Band 71 48 MHz in LTE Band 85
Impedance	50 ohm
Input power	ME910G1-W1: > 24dBm Average power ME910G1-WW: > 33dBm Average power
VSWR absolute max	≤ 10:1 (limit to avoid permanent damage)
VSWR recommended	≤ 2:1 (limit to fulfill all regulatory requirements)

Table 26: ME910G1 Antenna and Antenna transmission line on PCB

6.1.1. PCB Design guidelines

When using the ME910G1, since there's no antenna connector on the module, the antenna must be connected to the ME910G1 antenna pad (K1) by means of a transmission line implemented on the PCB.

This transmission line shall fulfil the following requirements:

Item	Value
Characteristic Impedance	50 ohm (+-10%)
Max Attenuation	0,3 dB
Coupling	Coupling with other signals shall be avoided
Ground Plane	Cold End (Ground Plane) of antenna shall be equipotential to the ME910G1 ground pins

Table 27: ME910G1 Antenna pad requirements

The transmission line should be designed according to the following guidelines:

- make sure that the transmission line's characteristic impedance is 50 ohm;
- keep line on the PCB as short as possible, since the antenna line loss shall be less than about 0,3 dB;
- line geometry should have uniform characteristics, constant cross section, avoid meanders and abrupt curves;
- any kind of suitable geometry / structure (Microstrip, Stripline, Coplanar, Grounded Coplanar Waveguide...) can be used to implement the printed transmission line afferent the antenna;
- if a Ground plane is required in line geometry, that plane shall be continuous and sufficiently extended, so that the geometry can be as similar as possible to the related canonical model;
- keep, if possible, at least one layer of the PCB used only for the Ground plane; If possible, use this layer as reference Ground plane for the transmission line;
- it is advisable to surround (on both sides) the PCB transmission line with Ground, avoiding that other signal tracks face directly the antenna line track.
- avoid crossing any un-shielded transmission line footprint with other signal tracks on different layers;
- the ground surrounding the antenna line on PCB shall be strictly connected to the main Ground Plane by means of via holes (once per 2mm at least), placed close to the ground edges facing the line track;

- place EM noisy devices as far as possible from ME910G1 antenna line;
- keep the antenna line far away from the ME910G1 power supply lines;
- if EM noisy devices (such as fast switching ICs, LCD and so on) are present on the PCB hosting the ME910, take care of the shielding of the antenna line by burying it in an inner layer of PCB and surrounding it with the Ground planes, or shield it with a metal frame cover.
- if EM noisy devices are not present around the line, the use of geometries such as Microstrip or Grounded Coplanar Waveguide is preferable, since they typically ensure less attenuation if compared to a Stripline of the same length.

The following image is showing the suggested layout for the Antenna pad connection:

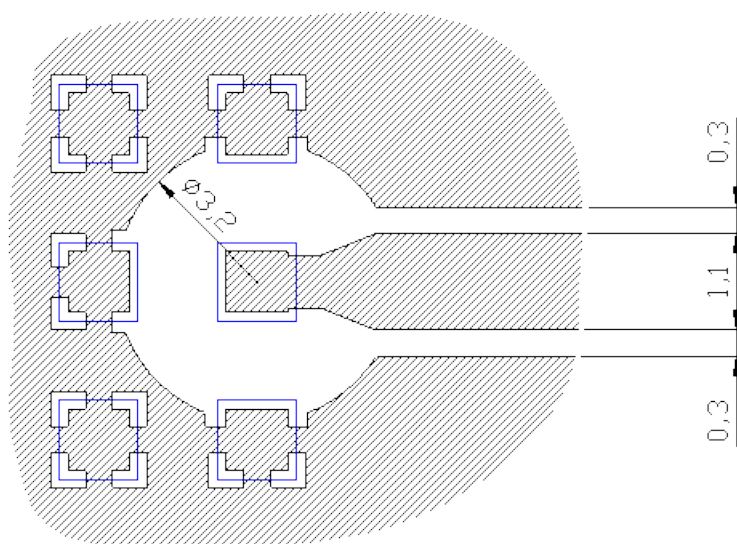

Figure 17: Layout for the Antenna pad connection

6.1.2. PCB Guidelines in case of FCC Certification

In the case FCC certification is required for an application using ME910G1, according to FCC KDB 996369 for modular approval requirements, the transmission line must be similar to the one implemented on the ME910G1 interface board and described in the following chapter.

6.1.2.1. Transmission line design

When designing the ME910G1 interface board, the placement of components was chosen properly, in order to keep the line length as short as possible, thus leading to the lowest possible power losses. A Grounded Coplanar Waveguide (G-CPW) line was chosen, since this kind of transmission line ensures good impedance control and can be implemented in an outer PCB layer as needed in this case. A SMA female connector has been used to feed the line.

The interface board is made on a FR4, 4-layers PCB. The substrate material is characterized by relative permittivity $\epsilon_r = 4.6 \pm 0.4 @ 1 \text{ GHz}$, $\text{TanD} = 0.019 \div 0.026 @ 1 \text{ GHz}$. A characteristic impedance of nearly $50 \ \Omega$ is achieved using trace width = 1.1 mm, clearance from a coplanar ground plane = 0.3 mm each side. The line uses the reference ground plane on layer 3, while copper is removed from layer 2 below the line. The height of the trace above ground plane is 1.335 mm. Calculated characteristic impedance is $51.6 \ \Omega$, the estimated line loss is less than 0.1 dB.

The line geometry is shown below:

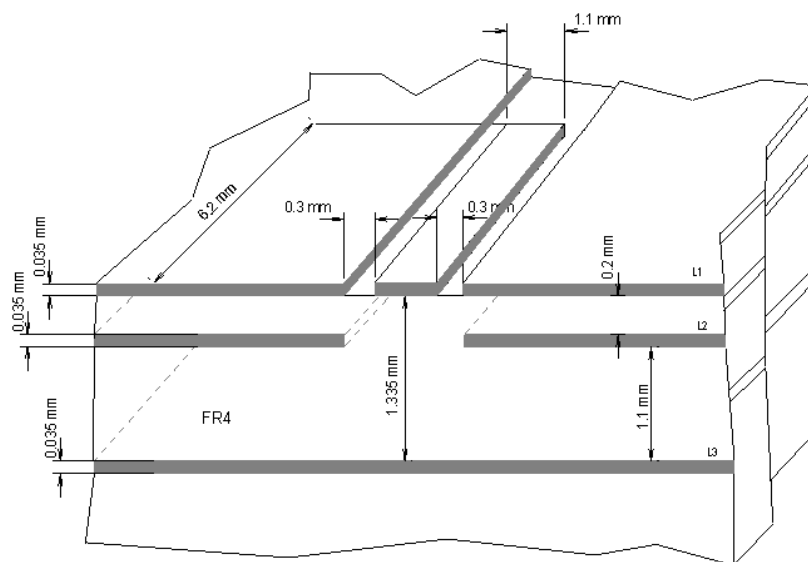

Figure 18: Line geometry

6.1.2.2. Transmission Line Measurements

An HP8753E VNA (Full-2-port calibration) was used in this measurement session.

A calibrated coaxial cable was soldered to the pad corresponding to RF output; a SMA connector was soldered to the board in order to characterize the losses of the

transmission line including the connector itself. During Return Loss / impedance measurements, the transmission line has been terminated to 50 Ω load.

Return Loss plot of line under test is shown below:

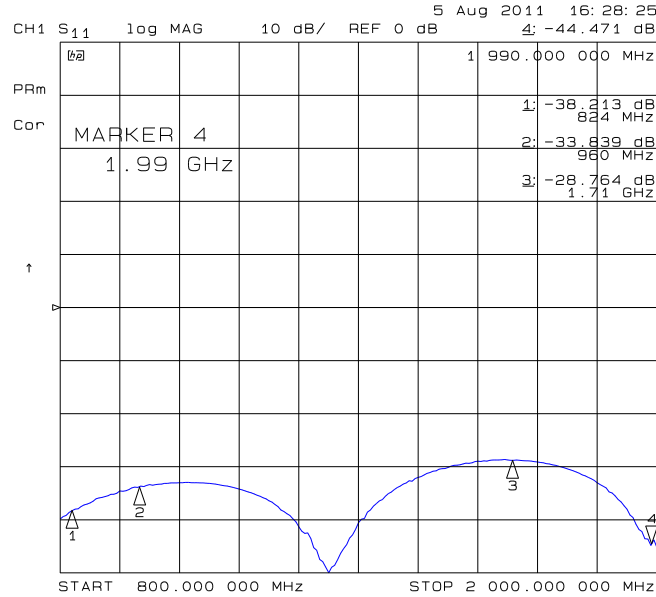

Figure 19: Return Loss plot of line under test

Line input impedance (in Smith Chart format, once the line has been terminated to 50 Ω load) is shown in the following figure:

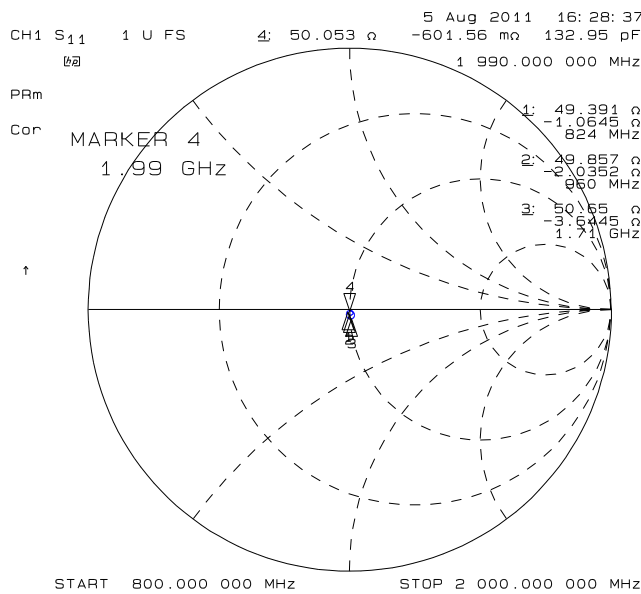

Figure 20: Line input impedance

Insertion Loss of G-CPW line plus SMA connector is shown below:

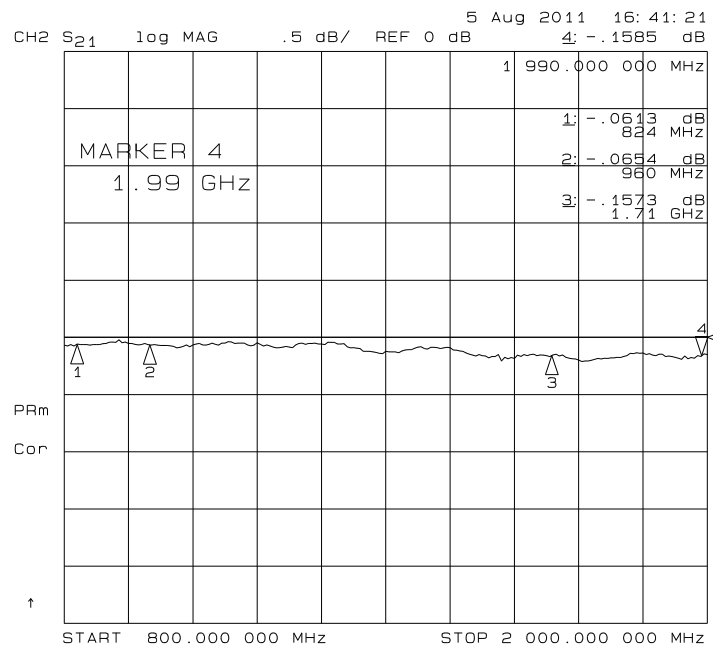

Figure 21: Insertion Loss of G-CPW line plus SMA connector

6.1.2.3. Antenna Installation Guidelines

- Install the antenna in a place covered by the LTE signal with CAT-M1 support.
- The Antenna must not be installed inside metal cases.
- The Antenna must be installed according Antenna manufacturer instructions.
- The Antenna integration should optimize the Radiation Efficiency. Efficiency values > 50% are recommended on all frequency bands.
- The Antenna integration should not perturb the radiation pattern described in the documentation of the Antenna manufacturer.
- It is preferable to get an omnidirectional radiation pattern.
- The Antenna Gain must not exceed the values indicated in regulatory requirements, where applicable, in order to meet related EIRP limitations. Typical antenna Gain in most M2M applications does not exceed 2dBi.
- If the device antenna is located farther than 20cm from the human body and there are no co-located transmitter then the Telit FCC/IC approvals can be re-used by the end product.
- If the device antenna is located closer than 20cm from the human body or there are co-located transmitter then the additional FCC/IC testing may be required for the end product (Telit FCC/IC approvals cannot be reused).

7. AUDIO SECTION

The Telit digital audio interface (DVI) of the ME910G1 Module is based on the I2S serial bus interface standard. The audio port can be connected to the end device using digital interface, or via one of the several compliant codecs (in case an analog audio is needed).

7.1. Electrical Characteristics

The product is providing the DVI on the following pins:

Pin	Signal	I/O	Function	Internal Pull Up	Type
B9	DVI_WA0	I/O	Digital Audio Interface (Word Alignment / LRCLK)		CMOS 1.8V
B6	DVI_RX	I	Digital Audio Interface (RX)		CMOS 1.8V
B7	DVI_TX	O	Digital Audio Interface (TX)		CMOS 1.8V
B8	DVI_CLK	I/O	Digital Audio Interface (BCLK)		CMOS 1.8V

Table 28: Pins DVI

8. GNSS SECTION

The ME910G1 module includes a state-of-art receiver that can simultaneously search and track satellite signals from multiple satellite constellations. This multi-GNSS receiver uses the entire spectrum of GNSS systems available: GPS, GLONASS, BeiDou, Galileo, and QZSS.

8.1. GNSS Signals Pin-out

Pin	Signal	I/O	Function	Type
R9	ANT_GNSS	I	GNSS Antenna (50 ohm)	
R7	GNSS_LNA_EN	O	GNSS External LNA Enable	CMOS 1.8V

Table 29: GNSS Signals Pin-out



Warning: GNSS_1PPS is not currently supported by software and it will be implemented in future SW releases.

8.2. RF Front End Design

The ME910G1 Module contains a pre-select SAW filter but does not contain the LNA necessary to achieve the maximum sensitivity. Active antenna (antenna with a built-in low noise amplifier) must be used and must be supplied with a proper bias-tee circuit.

8.2.1. Guidelines of PCB line for GNSS Antenna

- Make sure that the antenna line impedance is 50ohm.
- Keep the antenna line on the PCB as short as possible to reduce the loss.
- The Antenna line must have uniform characteristics, constant cross section, avoid meanders and abrupt curves.
- If possible, keep one layer of the PCB used only for the Ground plane.
- Surround (on both the sides, above and below) the antenna line on PCB with Ground, avoid having other signal tracks facing directly the antenna line of track.
- The ground around the antenna line on PCB must be strictly connected to the Ground Plane by placing vias once per 2mm at least.
- Place EM noisy devices as far as possible from antenna line.
- Keep the antenna line far away from power supply lines.

- Keep the antenna line far away from GSM RF lines.
- If there are noisy EM devices around the PCB hosting the module, such as fast switching ICs, take care of the shielding of the antenna line by burying it inside the layers of PCB and surround it with Ground planes, or shielding it with a metal frame cover.
- If there are not noisy EM devices around the PCB hosting the module, use a strip-line on the superficial copper layer for the antenna line. The line attenuation will be lower than a buried one.

8.2.2. Hardware-based solution for GNSS and LTE coexistence

When a stand-alone GNSS receiver is present in the user application, the LTE transmission may desensitize the GNSS receiver in particular if the decoupling between the LTE and GNSS antennas is low. A SAW filter can be added on LTE side, to protect GNSS receiver from LTE out-of-band emissions, as described in the schematic below.

When the GNSS receiver embedded in the ME910G1 module is used, there is no condition for degradation, since the LTE part and the GNSS part are never active simultaneously, therefore the filtering on the LTE side is not needed.

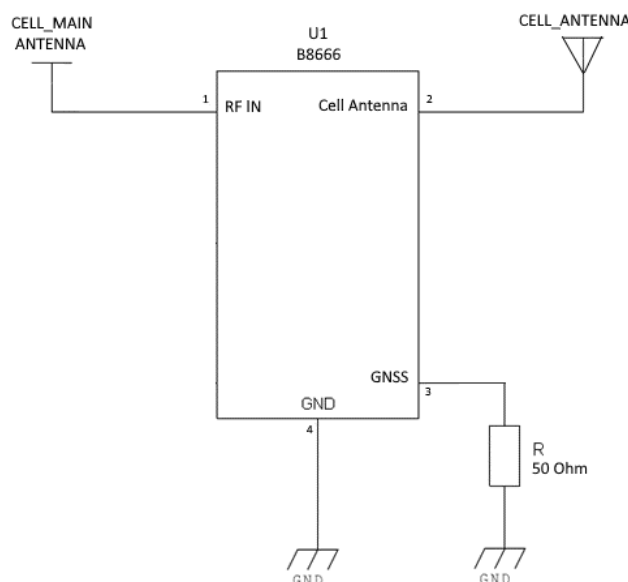

Figure 22: Reference schematic

8.3. GNSS Antenna Requirements

GNSS active antenna must be used or integrated in the application.

8.3.1. GNSS Antenna specification

Item	Value
Frequency range	1559.0 ~ 1610.0 MHz
Gain	15 ~ 30dB
Impedance	50 ohm
Noise Figure of LNA	< 1.5 (recommended)
DC supply voltage	DC 1.8 ~ 3.3V
VSWR	≤ 3:1 (recommended)

Table 30: GNSS Antenna specification



Note: In case of GNSS antenna placed close to module 15dB gain is enough, in case of long cable the gain has to be increased up to 30dB.

8.3.2. GNSS Antenna – Installation Guidelines

- The antenna must be installed according to the antenna manufacturer's instructions to obtain the maximum performance of GNSS receiver.
- The antenna location must be carefully evaluated if operating in conjunction with any other antenna or transmitter.
- The antenna must not be installed inside metal cases or near any obstacle that may degrade features such as antenna lobes and gain.

8.3.3. Powering the External LNA (active antenna)

The LNA of active antenna needs a power source because 1.8V or 3V DC voltage required by the active antenna is not supplied by the ME910G1 module but can be easily included by the host design.

The electrical characteristics of the GPS_LNA_EN signal are:

Level	Min	Max
Output High Level	1.6V	1.9V
Output Low Level	0V	0.3V

Table 31: Electrical characteristics of the GPS_LNA_EN

Example of external antenna bias circuitry:

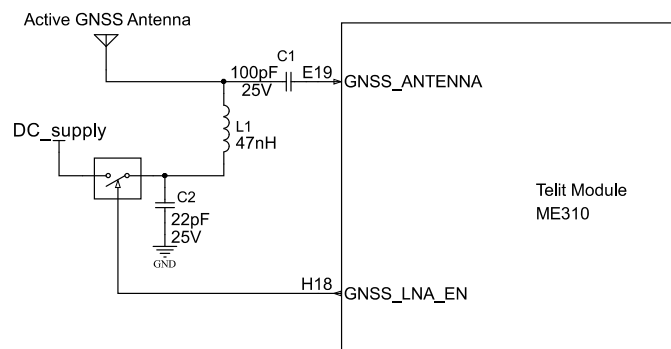

Figure 23: External antenna bias circuitry example

Be aware of max bias current in case of unwanted short on the antenna cable, since the decoupling inductor may be damaged.

In case of LNA with 1.8V supply, VAUX/POWERMON pin can be used to supply active GNSS antenna

8.4. GNSS Characteristics

The table below specifies the GNSS characteristics and expected performance:

Parameters		Typical Measurement	Notes
Sensitivity	Tracking Sensitivity	-159 dBm	
	Navigation	-155 dBm	
	Cold Start	-144 dBm	
TTFF	Hot	N/A	It will be available in next revision
	Warm	<30s	GNSS Simulator test @-130dBm
	Cold	<30s	GNSS Simulator test @-130dBm
Min Navigation update rate		1Hz	
CEP		<2m	

Table 32: GNSS characteristics

9. MECHANICAL DESIGN

9.1. Drawing

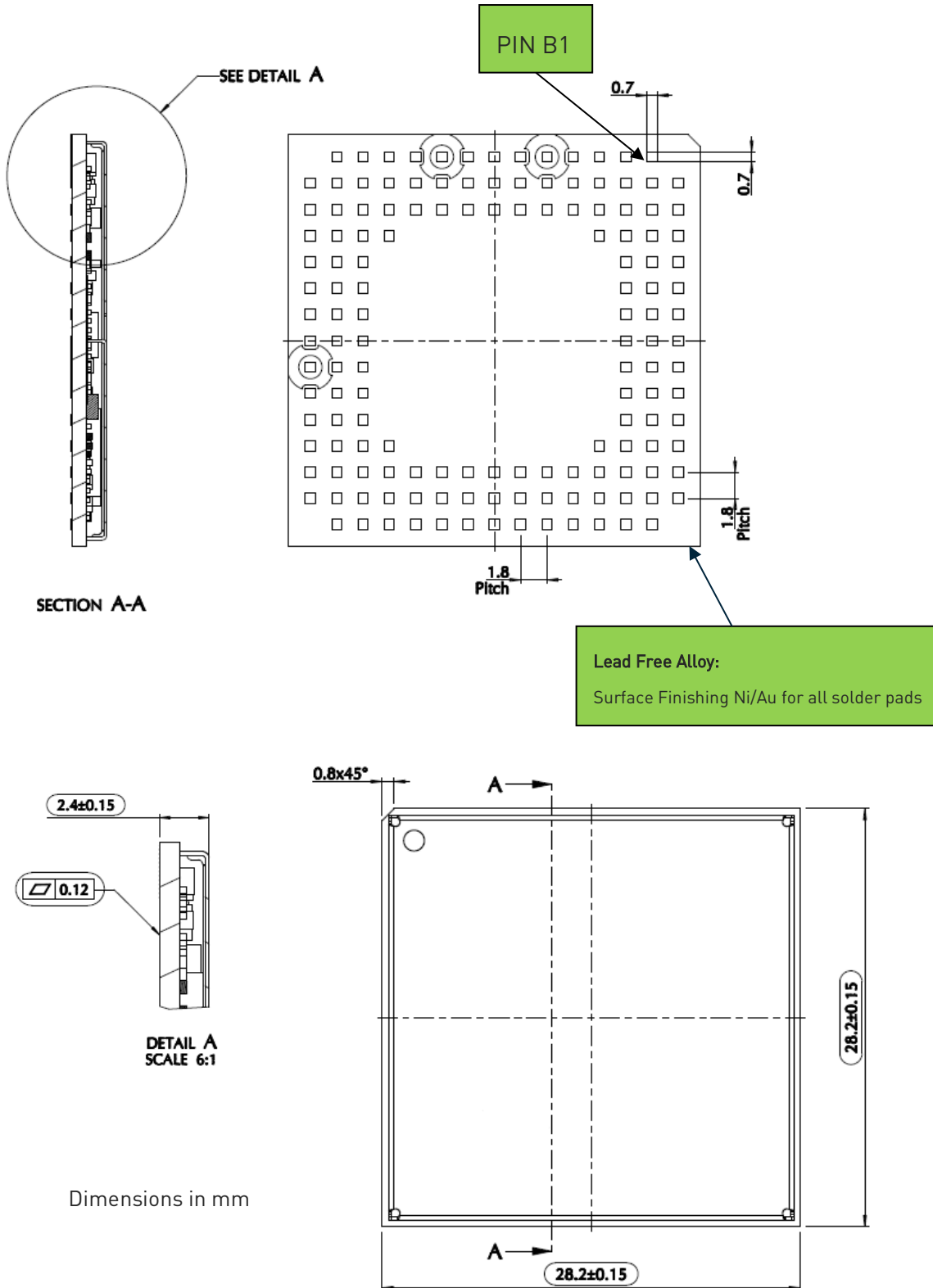

Figure 24: ME910G1 Mechanical Drawing

10. APPLICATION PCB DESIGN

The ME910G1 modules have been designed in order to be compliant with a standard lead-free SMT process

10.1. Recommended footprint for the application

TOP VIEW

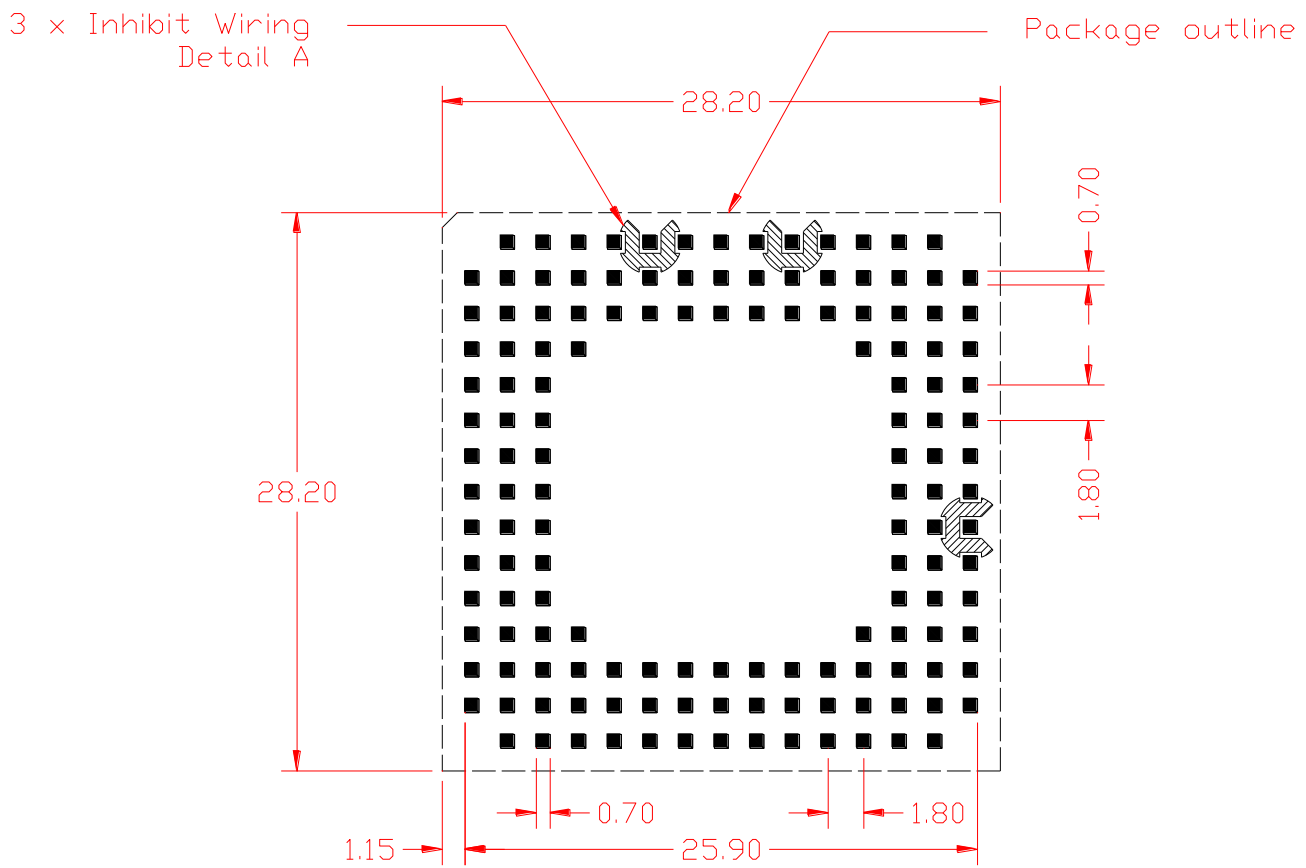
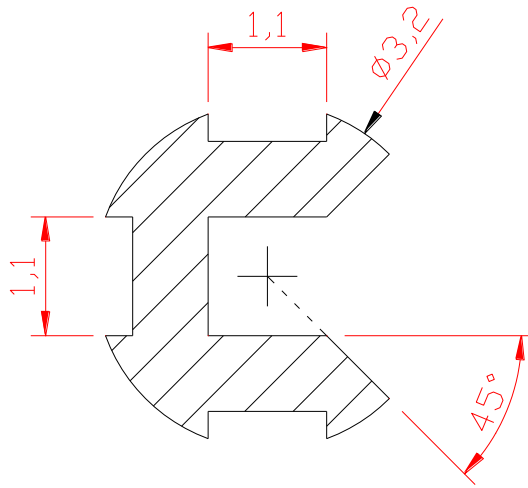

Figure 25: Footprint

SOLDER RESIST PATTERN (dimensions in mm)



Detail A

Figure 26:: Solder resist pattern

TOP TRANSPARENT VIEW

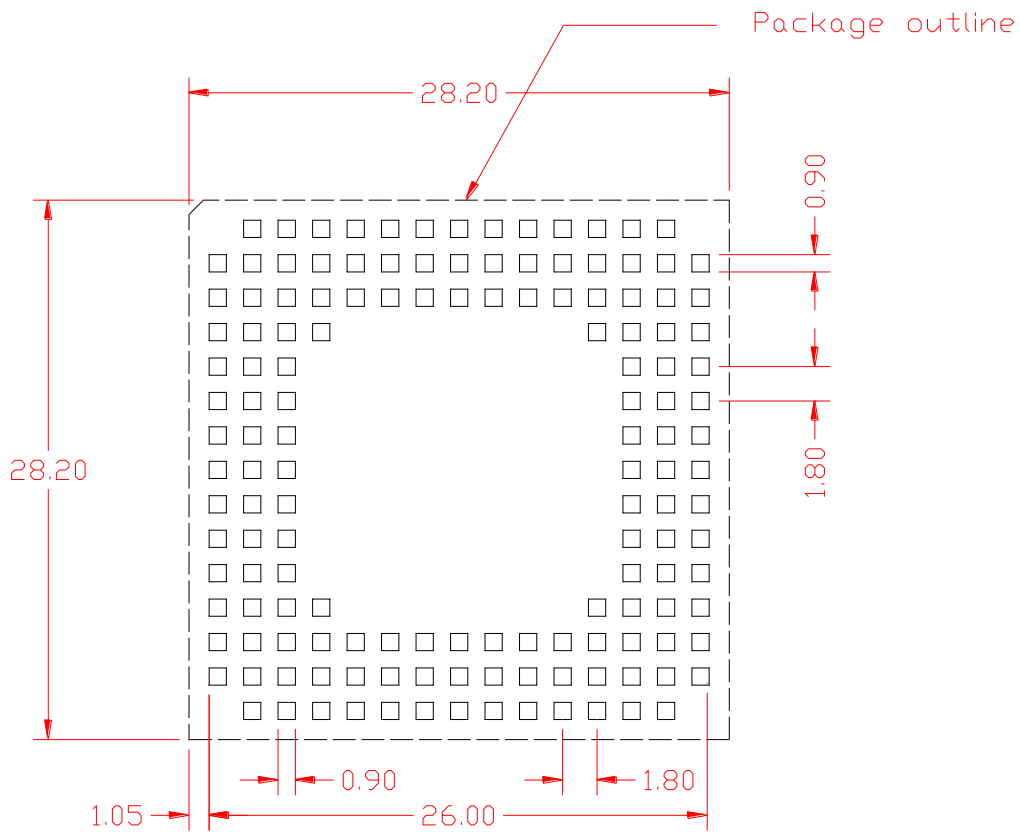

Figure 27: Top transparent view

In order to easily rework the ME910G1 it is recommended to consider on the application a 1.5 mm placement inhibit area around the module.

It is also suggested, as common rule for an SMT component, to avoid having a mechanical part of the application in direct contact with the module.



Note: In the customer application, the region under WIRING INHIBIT (see figure above) must be clear from signal or ground paths.

10.2. PCB pad design

In PCB design, the solder pads can be defined as either Solder Mask Defined (SMD) or Non-Solder Mask Defined (NSMD). The difference between these two solder mask pad definitions, is in the closeness of the solder mask to the metal pad. In SMD pads, the solder mask opening is smaller than the metal pad and overlaps the metal on all sides. The solder mask opening defines the solderable area of the pad. In NSMD pads, the solder mask opening is larger than the metal pad and does not overlap the metal. The metal edge defines the solderable area of the pad (see Figure below).

Since the metal etching process in PCB manufacture, has significantly tighter alignment and etching tolerances than the alignment registration of the solder masking process, which, a more accurate solder pad land pattern can be obtained with NSMD pads. In addition, with SMD pads, the solder mask that overlaps the metal pad introduces additional height above the metal surface that may affect solder joint adhesion and reliability. Non solder mask defined (NSMD) type is recommended for the solder pads on the PCB.

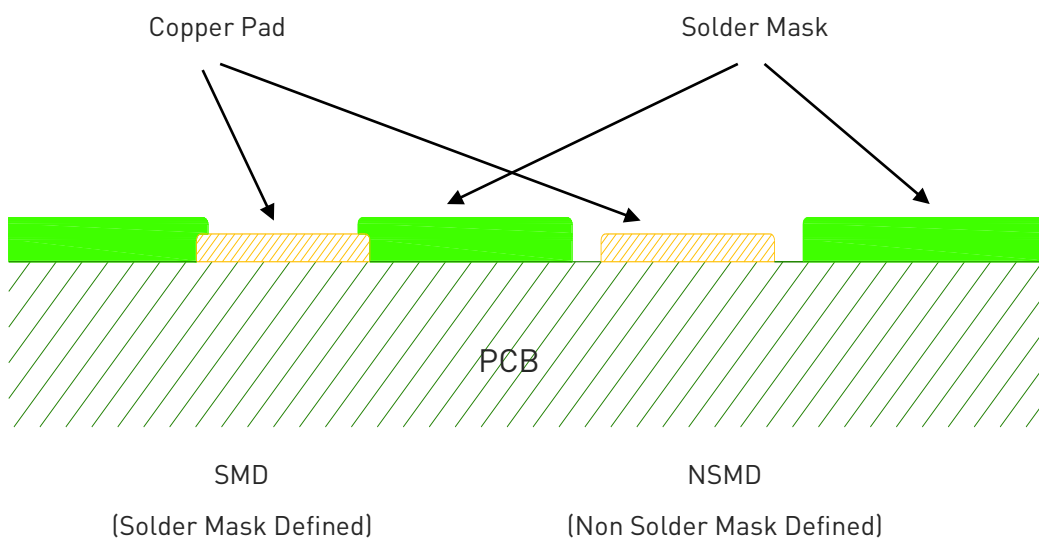

Figure 28: PCB solder pad recommendations
1W0301593 Rev.7

10.3. Recommendations for PCB pad dimensions

It is not recommended to place via or micro-via not covered by solder resist in an area of 0,3 mm around the pads unless it carries the same signal of the pad itself

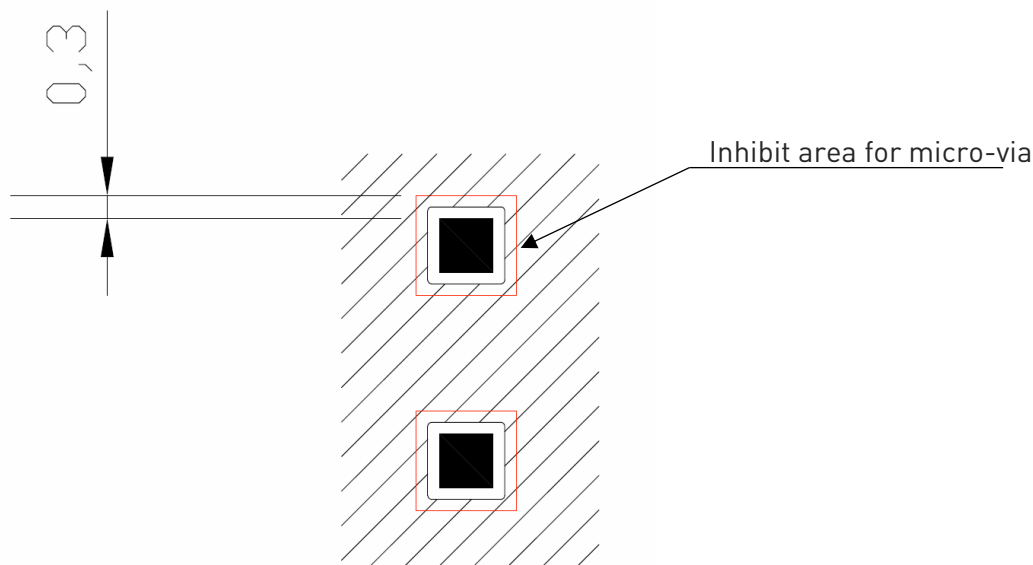

Figure 29: Pad dimensions recommendations

Holes in pad are allowed only for blind holes and not for through holes.

Recommendations for PCB pad surfaces:

Finish	Layer Thickness (um)	Properties
Electro-less Ni / Immersion Au	3 -7 / 0.05 - 0.15	good solder ability protection, high shear force values

Table 33: Recommendations for PCB pad surfaces

The PCB must be able to resist the higher temperatures that occur during the lead-free process. This issue should be discussed with the PCB-supplier. Generally, the wettability of tin-lead solder paste on the described surface plating is better compared to the lead-free solder paste.

It is not necessary to panel the application's PCB, however in that case it is recommended to use milled contours and predrilled board breakouts; scoring or v-cut solutions are not recommended.

10.4. Thermal performance

FR4 is one of the most commonly used PCB materials, it is a flame retardant composite material, composed by fiberglass-reinforced and epoxy laminate. One of the features of the FR4, is to have a very low thermal conductivity. An inexpensive way to improve thermal

transfer for FR-4 PCBs is to add thermal vias - plated through-holes (PTH) between the conductive layers. Vias are created by drilling holes and copper plating them, in the same way that a PTH or via is used for electrical interconnections between layers. A series of plated through-hole thermal vias, should be located in the GND area underneath Telit module of the PCB to provide a thermal connection from the PCB GND to additional metal layers of the PCB.

The application PCB layout should include plated through-hole thermal vias for efficient heat dissipation from the Telit module into the PCB. One of the following thermal via types should be used:

- Open plated through-hole vias that will provide lower PCB fabrication costs but may fill with solder.
- Plugged and capped plated through-hole vias that will provide higher PCB fabrication costs but will not fill with solder.

Telit recommends creating areas of 10 mil (0.254-mm) vias arranged on a 25 mil (0.635-mm) rectilinear matrix. The reason for this choice is the combination of cost, performance and manufacturability. According to several PCB manufacturers, 10-mil holes and 25-mil spacing are reasonable and repeatable production choice.

A uniform metal plating thickness on the PCB will ensure reliable, high Telit module solder assembly yield.

10.5. Stencil

A silk-screen process will be required for the deposition of solder paste to the PCB, for reflow of the Telit module to the PCB. The silk-screen process requires the use of an aperture based metal stencil where solder paste is transferred through the apertures onto the solder pads of the application PCB. To minimize solder voids and ensure maximum electrical and thermal connectivity of the module to the PCB, large pads, solder volume, and solder straining must be considered in the stencil design. The design and fabrication of the stencil determines the quality of the solder paste deposition onto the PCB and the resulting solder joint after reflow. The primary stencil parameters are aperture size, thickness, and fabrication method. The stencil should be made from stainless steel and the apertures layout can be the same of the recommended footprint (1:1). The recommended thickness shall be 127 μm (5 mil). A stencil thickness of 152 μm (6 mil) can be used as well.

10.6. Solder paste

Various types and grades of solder paste can be used for surface mounting Telit modules. For leadfree applications, a Sn-Ag (SA) or Sn-Ag-Cu (SAC) solder paste can be used. Any Type 3 solder paste that is either water-soluble or no clean is acceptable.

We recommend using only “no clean” solder paste in order to avoid the cleaning of the modules after assembly.

10.7. Solder Reflow

Recommended solder reflow profile:

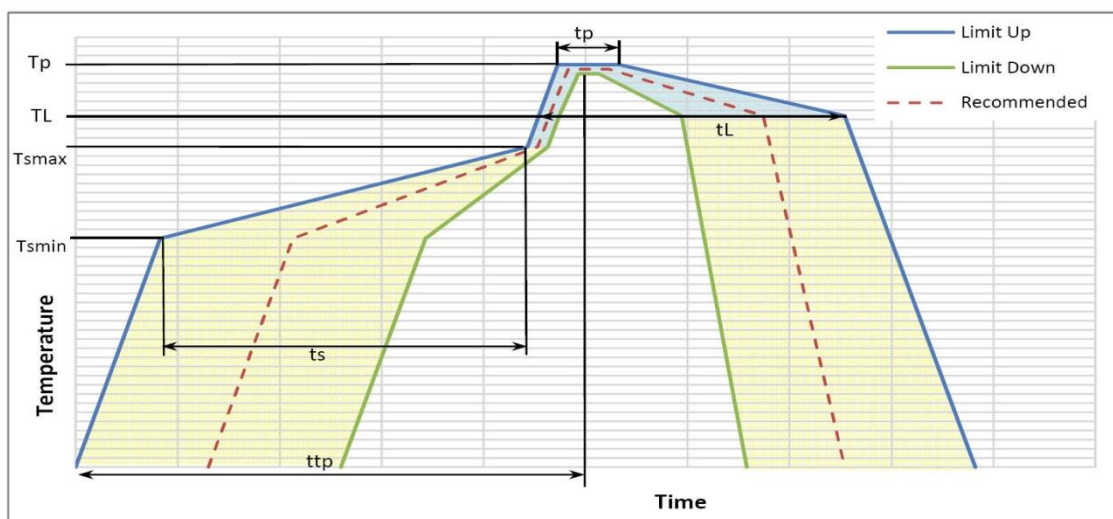

Figure 30: Recommended solder reflow profile

Profile Feature	Pb-Free Assembly Free
Average ramp-up rate (TL to Tp)	3°C/second max
Preheat – Temperature Min (Tsmmin) – Temperature Max (Tsmmax) – Time (min to max) (ts)	150°C 200°C 60-180 seconds
Tsmmax to TL – Ramp-up Rate	3°C/second max
Time maintained above: – Temperature (TL) – Time (tL)	217°C 60-150 seconds
Peak Temperature (Tp)	245 +0/-5°C
Time within 5°C of actual Peak Temperature (tp)	10-30 seconds
Ramp-down Rate	6°C/second max.
Time 25°C to Peak Temperature	8 minutes max.

Table 34: Profile feature recommendations
1W0301593 Rev.7



Note: All temperatures refer to topside of the package, measured on the package body surface



Warning: THE ME910G1 MODULE WITHSTANDS ONE REFLOW PROCESS ONLY.



Warning: The above solder reflow profile represents the typical SAC reflow limits and does not guarantee adequate adherence of the module to the customer application throughout the temperature range. Customer must optimize the reflow profile depending on the overall system taking into account such factors as thermal mass and warpage.

10.8. Inspection

An inspection of the solder joint between the solder pads of the Telit module and the application PCB should be performed. The best visual inspection tool for inspection of the Telit module solder joints on the PCB is a transmission X-ray, which can identify defects such as solder bridging, shorts, opens, and large voids (Note: small voids in large solder joints are not detrimental to the reliability of the solder joint).

11. PACKAGING

11.1. Tray

The ME910 modules are packaged on trays that can be used in SMT processes for pick & place handling. The first Marketing and Engineering samples of the ME910G1 series will be shipped with the current packaging of the xE910 modules (on trays of 20 pieces each). Please note that Telit is going to introduce a new packaging for the xE910 family, as per the Product Change Notification PCN-0000-14-0055, therefore the mass production units of ME910G1 will be shipped according to the following drawings:

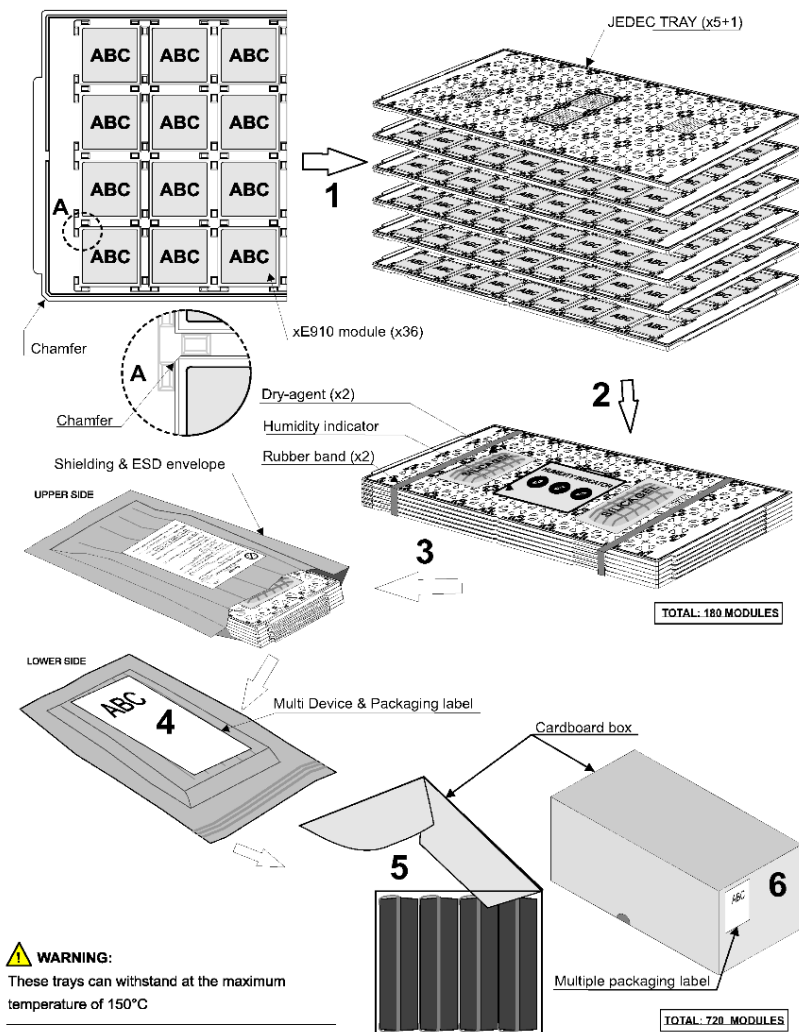

Figure 31: Tray packaging

11.2. Reel

The ME910 can be packaged on reels of 200 pieces each. See figure for module positioning into the carrier.

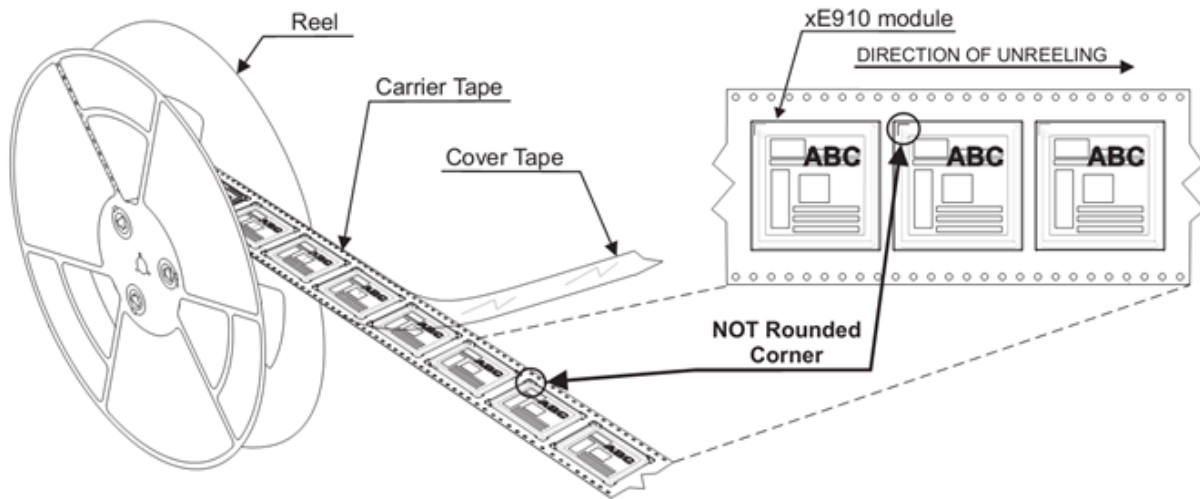

Figure 33: Module positioning into the carrier

11.3. Carrier Tape detail

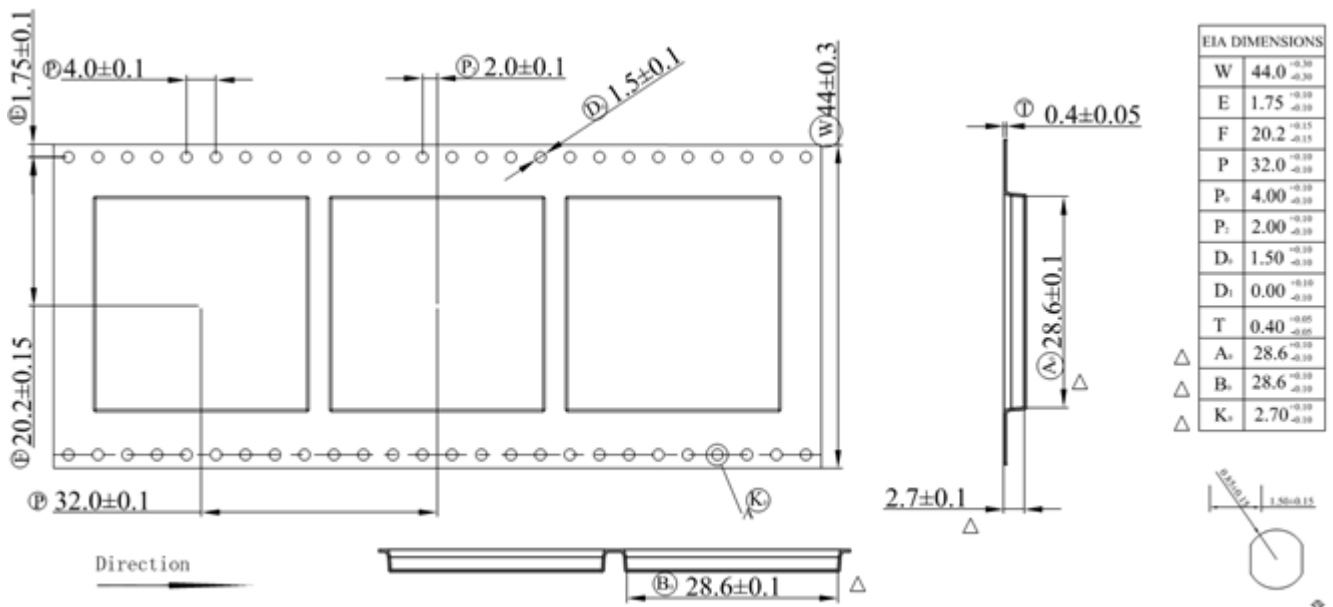

Figure 34: Carrier Tape detail

11.4. Reel detail

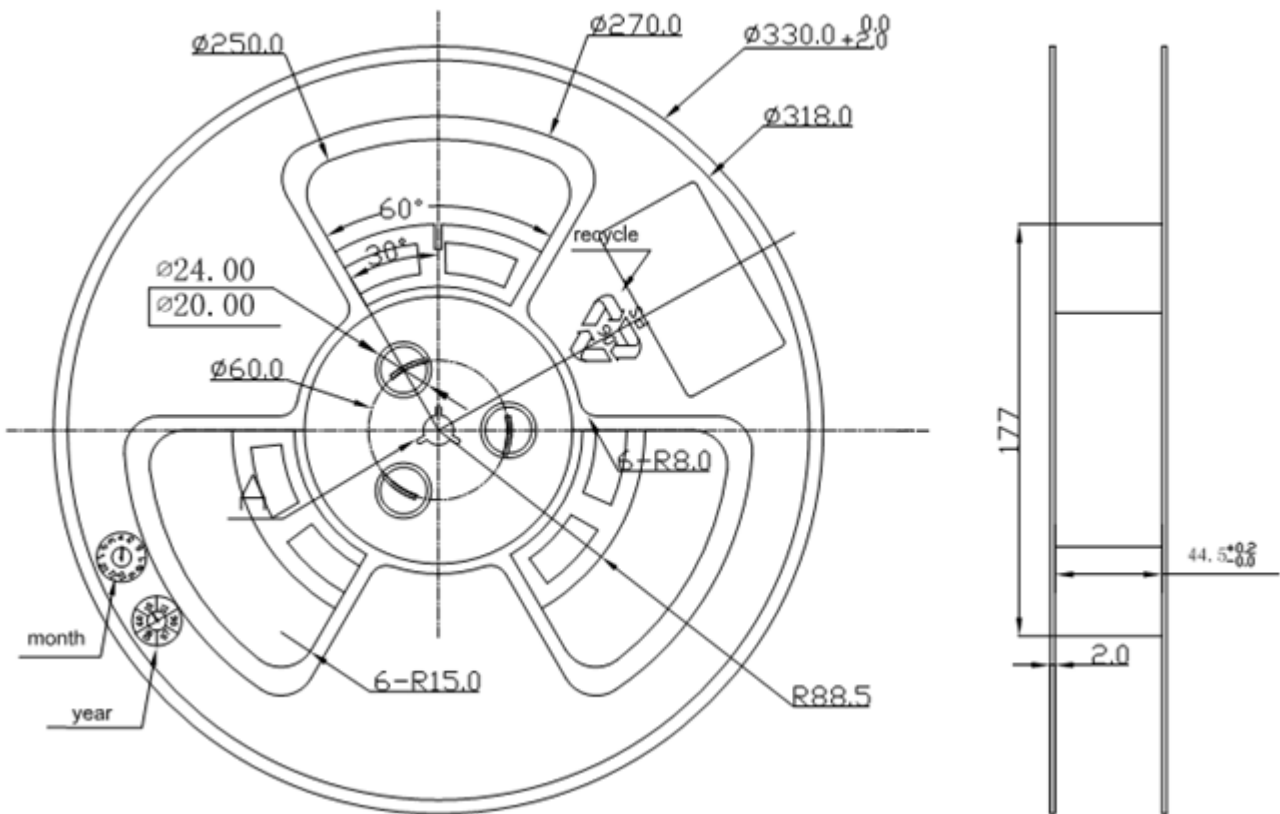

Figure 35: Reel detail

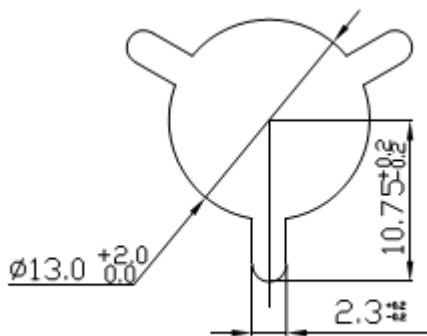

Figure 36: Detail

11.5. Packaging detail

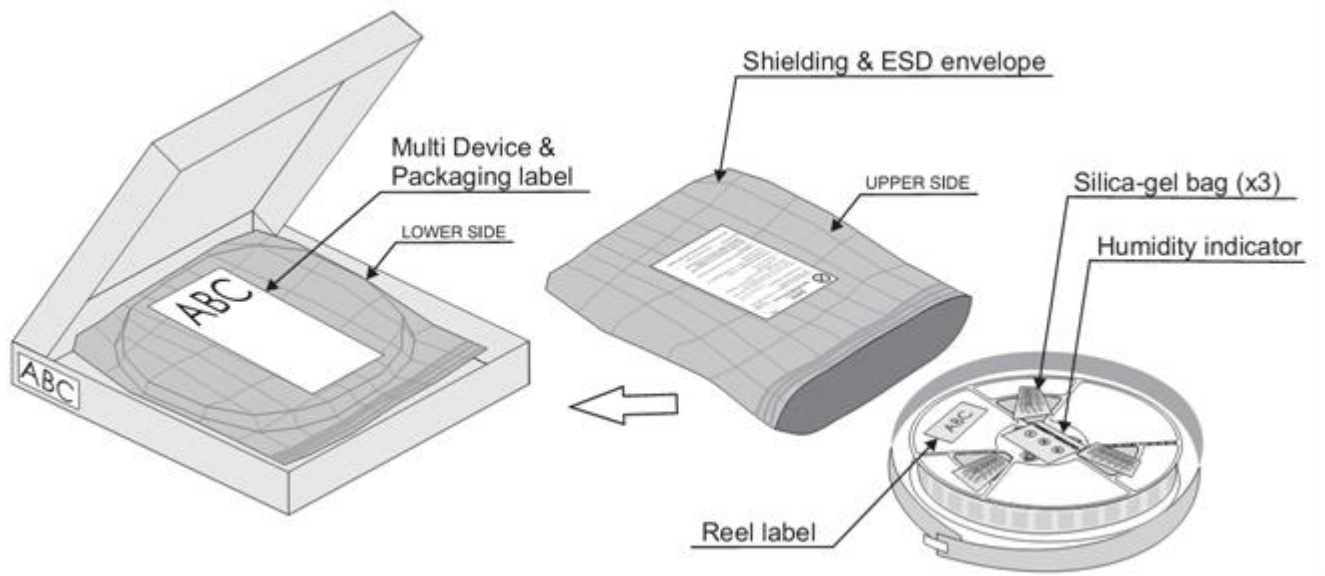

Figure 37: Packaging detail

11.6. Moisture sensitivity

The ME910G1 is a Moisture Sensitive Device level 3, in according with standard IPC/JEDEC J-STD-020, take care all the relatives requirements for using this kind of components.

Moreover, the customer has to take care of the following conditions:

- a) Calculated shelf life in sealed bag: 12 months at 40°C and 90% relative humidity (RH).
- b) Environmental condition during the production: 30°C / 60% RH according to IPC/JEDEC J-STD-033A paragraph 5.
- c) The maximum time between the opening of the sealed bag and the reflow process must be 168 hours if condition b) "IPC/JEDEC J-STD-033D paragraph 5.2" is respected
- d) Baking is required if conditions b) or c) are not respected
- e) Baking is required if the humidity indicator inside the bag indicates 10% RH or more

12. CONFORMITY ASSESSMENT ISSUES

12.1. Approvals summary

Type Approval	ME910G1-W1	ME910G1-WW	ME910G1-WWV
EU RED	Yes	Yes	Yes
US FCC	Yes	Yes	Yes
CA ISED	Yes	Yes	Yes
BRAZIL ANATEL	-	Yes	-
JAPAN JRF & JTBL	-	Yes	-
CHINA CCC	-	Ongoing	-

Table 35: Approvals summary

12.2. RED approval

12.2.1. RED Declaration of Conformity

Hereby, Telit Communications S.p.A declares that the ME910G1-W1, ME910G1-WW and ME910G1-WWV Modules are in compliance with Directive 2014/53/EU.

The full text of the EU declaration of conformity is available at the following internet address: <http://www.telit.com/red>

Text of 2014/53/EU Directive (RED) can be found here:

<https://eur-lex.europa.eu/legal-content/EN/TXT/?uri=CELEX:32014L0053>

12.2.2. Antennas

This radio transmitter has been approved under RED to operate with the antenna types listed below with the maximum permissible gain indicated. The usage of a different antenna in the final hosting device may need a new assessment of host conformity to RED.

Model	Antenna Type
ME910G1-W1	Omnidirectional Antenna Gain 2.14 dBi
ME910G1-WW	
ME910G1-WWV	

Table 36: RED Antenna Type

Max Gain for RED (dBi)			
Band	ME910G1-W1	ME910G1-WW	ME910G1-WWV
GSM 900	---	---	TBD
DCS 1800	---	---	TBD
GPRS/EGPRS 900	---	5.47	5.47
GPRS/EGPRS 1800	---	9.34	9.34
FDD 1	14.84	11.84	11.84
FDD 3	14.33	11.33	11.33
FDD 8	11.45	8.45	8.45
FDD 20	11.20	8.20	8.20
FDD 28	10.47	7.47	7.47

Table 37: Max Gain for RED

12.3. FCC and ISED approval/*FCC et ISDE approbation*

12.3.1. FCC certificates

The FCC Certificate is available here:

<https://www.fcc.gov/oet/ea/fccid>

12.3.2. ISED Certificate/*ISDE certificates*

The ISED Certificate is available here / *Le certificat ISDE est disponible ici:*

<https://sms-sgs.ic.gc.ca/equipmentSearch/searchRadioEquipments?execution=e1s1&lang=en>

12.3.3. Applicable FCC and ISED rules/*Liste des règles FCC et ISDE applicables*

Model <i>Modèle</i>	Applicable FCC Rules	Applicable ISED Rules <i>Règles ISDE applicables</i>
ME910G1-W1	47 CFR Part 2, 22, 24, 27, 90	RSS: 132 Issue3, 133 Issue 6, 130 Issue 2, 139 Issue 3; RSS-Gen Issue 5
ME910G1-WW		
ME910G1-WWV		

Table 38: Applicable FCC and ISED rules

12.3.4. FCC and ISED Regulatory notices / *Avis réglementaires de FCC et ISDE*

Modification statement / *Déclaration de modification*

Telit has not approved any changes or modifications to this device by the user. Any changes or modifications could void the user's authority to operate the equipment.

Telit n'approuve aucune modification apportée à l'appareil par l'utilisateur, quelle qu'en soit la nature. Tout changement ou modification peuvent annuler le droit d'utilisation de l'appareil par l'utilisateur.

Interference statement / *Déclaration d'interférence*

This device complies with Part 15 of the FCC Rules and Industry Canada licence-exempt RSS standard(s). Operation is subject to the following two conditions: (1) this device may not cause interference, and (2) this device must accept any interference, including interference that may cause undesired operation of the device.

Le présent appareil est conforme aux CNR d'Industrie Canada applicables aux appareils radio exempts de licence. L'exploitation est autorisée aux deux conditions suivantes : (1) l'appareil ne doit pas produire de brouillage, et (2) l'utilisateur de l'appareil doit accepter tout brouillage radioélectrique subi, même si le brouillage est susceptible d'en compromettre le fonctionnement.

Wireless notice / *Wireless avis*

This device complies with FCC/ISED radiation exposure limits set forth for an uncontrolled environment and meets the FCC radio frequency (RF) Exposure Guidelines and RSS-102 of the ISED radio frequency (RF) Exposure rules. This transmitter must not be co-located or operating in conjunction with any other antenna or transmitter. The antenna should be installed and operated with minimum distance of 20 cm between the radiator and your body.

Le présent appareil est conforme à l'exposition aux radiations FCC / ISED définies pour un environnement non contrôlé et répond aux directives d'exposition de la fréquence de la FCC radiofréquence (RF) et RSS-102 de la fréquence radio (RF) ISED règles d'exposition. L'émetteur ne doit pas être colocalisé ni fonctionner conjointement avec à autre antenne ou autre émetteur. L'antenne doit être installée de façon à garder une distance minimale de 20 centimètres entre la source de rayonnements et votre corps.

FCC Class B digital device notice (FCC only)

This equipment has been tested and found to comply with the limits for a Class B digital device, pursuant to part 15 of the FCC Rules. These limits are designed to provide

reasonable protection against harmful interference in a residential installation. This equipment generates, uses and can radiate radio frequency energy and, if not installed and used in accordance with the instructions, may cause harmful interference to radio communications. However, there is no guarantee that interference will not occur in a particular installation. If this equipment does cause harmful interference to radio or television reception, which can be determined by turning the equipment off and on, the user is encouraged to try to correct the interference by taking one or more of the following measures:

Reorient or relocate the receiving antenna.

- Increase the separation between the equipment and receiver.
- Connect the equipment into an outlet on a circuit different from that to which the receiver is connected.
- Consult the dealer or an experienced radio/TV technician for help.

CAN ICES-3 (B) / NMB-3 (B) (ISED only) / *(ISDE seulement)*

This Class B digital apparatus complies with Canadian ICES-003.

Cet appareil numérique de classe B est conforme à la norme canadienne ICES-003.

12.3.5. Antennas/Antennes

FCC

This radio transmitter has been approved by FCC and ISED to operate with the antenna types listed below with the maximum permissible gain indicated. Antenna types not included in this list, having a gain greater than the maximum gain indicated for that type, are strictly prohibited for use with this device.

Model	Antenna Type
ME910G1-W1	Omnidirectional Antenna Gain 2.14 dBi
ME910G1-WW	
ME910G1-WWV	

Table 39: FCC Antenna Type

Max Gain for FCC (dBi)			
Band	ME910G1-W1	ME910G1-WW	ME910G1-WWV
GSM 850	---	---	8.44
GSM 1900	---	---	10.04
GPRS/EGPRS 850	---	6.93	6.93
GPRS/EGPRS 1900	---	10.42	10.42
FDD 2	11.0	12.01	12.01
FDD 4	8.0	12.01	12.01
FDD 5	12.4	9.41	9.41
FDD 12	11.6	8.70	8.70
FDD 13	12.1	9.16	9.16
FDD 25	11.0	12.01	12.01
FDD 26	12.3	9.36	9.36
FDD 66	8.0	12.01	12.01
FDD 71	11.4	11.47	11.47
FDD 85	11.6	8.69	8.69
FDD 86	12.1	---	---

Table 40: Max Gain for FCC (dBi)

ISED / ISDE

This radio transmitter has been approved by ISED to operate with the antenna types listed below with the maximum permissible gain indicated. Antenna types not included in this list, having a gain greater than the maximum gain indicated for that type, are strictly prohibited for use with this device.

Le présent émetteur radio a été approuvé par ISDE pour fonctionner avec les types d'antenne énumérés ci-dessous et ayant un gain admissible maximal. Les types d'antenne non inclus dans cette liste, et dont le gain est supérieur au gain maximal indiqué, sont strictement interdits pour l'exploitation de l'émetteur.

Model Modèle	Antenna Type Type d'Antenne
ME910G1-W1	Omnidirectional Antenna Gain 2.14 dBi <i>Omnidirectionelle</i> <i>Gain de l'antenne 2.14 dBi</i>
ME910G1-WW	
ME910G1-WWV	

Table 41: ISED Antenna Type

Gain maximum pour ISED (dBi) / Gain maximum pour ISDE (dBi)			
Bande	ME910G1-W1	ME910G1-WW	ME910G1-WWV
GSM 850			5.15
GSM 1900			10.04
GPRS/EGPRS 850	---	3.64	3.64
GPRS/EGPRS 1900	---	5.13	5.13
FDD 2	11.0	8.52	8.52
FDD 4	8.0	8.29	8.29
FDD 5	9.1	6.12	6.12
FDD 12	8.6	5.63	5.63
FDD 13	8.9	5.95	5.95
FDD 25	11.0	8.52	8.52
FDD 26	9.0	6.09	6.09
FDD 66	8.0	8.29	8.29
FDD 71	8.4	8.48	8.48
FDD 85	8.6	5.63	5.63

Table 42: Gain maximum for ISED (dBi)

12.3.6. FCC label and compliance information

The product has a FCC ID label on the device itself. Also, the OEM host end product manufacturer will be informed to display a label referring to the enclosed module. The exterior label will read as follows: "Contains Transmitter Module FCC ID: RI7ME910G1W1" or "Contains FCC ID: RI7ME910G1W1" for ME910G1-W1 and : "Contains Transmitter Module FCC ID: RI7ME910G1WW" or "Contains FCC ID: RI7ME910G1WW" for ME910G1-WW and ME910G1-WWV

Below list of all the models and related FCC ID:

Model	FCC ID
ME910G1-W1	RI7ME910G1W1
ME910G1-WW	RI7ME910G1WW
ME910G1-WWV	

Table 43: FCC ID

12.3.7. ISED label and compliance information/ *Étiquette et informations de conformité ISDE*

The host product shall be properly labelled to identify the modules within the host product.

The ISED certification label of a module shall be clearly visible at all times when installed in the host product; otherwise, the host product must be labelled to display the ISED certification number for the module, preceded by the word "contains" or similar wording expressing the same meaning, as follows:

Contains IC: XXXXXX-YYYYYYYYYYY

In this case, XXXXXX-YYYYYYYYYYY is the module's certification number.

Le produit hôte devra être correctement étiqueté, de façon à permettre l'identification des modules qui s'y trouvent.

L'étiquette d'homologation d'un module d'ISDE devra être apposée sur le produit hôte à un endroit bien en vue, en tout temps. En l'absence d'étiquette, le produit hôte doit porter une étiquette sur laquelle figure le numéro d'homologation du module d'ISDE, précédé du mot « contient », ou d'une formulation similaire allant dans le même sens et qui va comme suit :

Contient IC : XXXXXX-YYYYYYYYYYY

Dans ce cas, XXXXXX-YYYYYYYYYYY est le numéro d'homologation du module.

Model Modèle	ISED Certification Number Num. de certification ISDE
ME910G1-W1	5131A-ME910G1W1
ME910G1-WW	5131A-ME910G1WW
ME910G1-WWV	

Table 44: ISED Certification Number

12.3.8. Information on test modes and additional testing requirements / *Informations sur les modes de test et les exigences de test supplémentaires*

The module has been evaluated in mobile stand-alone conditions. For different operational conditions from a stand-alone modular transmitter in a host (multiple, simultaneously transmitting modules or other transmitters in a host), additional testing may be required (collocation, retesting...)

If this module is intended for use in a portable device, you are responsible for separate approval to satisfy the SAR requirements of FCC Part 2.1093 and IC RSS-102.

Le module a été évalué dans des conditions autonomes mobiles. Pour différentes conditions de fonctionnement d'un émetteur modulaire autonome dans un hôte (plusieurs modules émettant simultanément ou d'autres émetteurs dans un hôte), des tests supplémentaires peuvent être nécessaires (colocalisation, retesting...)

Si ce module est destiné à être utilisé dans un appareil portable, vous êtes responsable de l'approbation séparée pour satisfaire aux exigences SAR de la FCC Partie 2.1093 et IC RSS-102.

12.3.9. FCC Additional testing, Part 15 Subpart B disclaimer

The modular transmitter is only FCC authorized for the specific rule parts (i.e., FCC transmitter rules) listed on the grant, and that the host product manufacturer is responsible for compliance to any other FCC rules that apply to the host not covered by the modular transmitter grant of certification. If the grantee markets their product as being Part 15 Subpart B compliant (when it also contains unintentional-radiator digital circuitry), then the grantee shall provide a notice stating that the final host product still requires Part 15 Subpart B compliance testing with the modular transmitter installed. The end product with an embedded module may also need to pass the FCC Part 15 unintentional emission testing requirements and be properly authorized per FCC Part 15.

12.4. ANATEL Regulatory Notices



"Este equipamento não tem direito à proteção contra interferência prejudicial e não pode causar interferência em sistemas devidamente autorizados"

"This equipment is not entitled to protection against harmful interference and must not cause interference in duly authorized systems"

ME910G1-WW, ME310G1-WW, ML865G1-WW Homologation #: 08566-20-02618

12.5. NCC Regulatory Notices

According to NCC Taiwan requirements, the module and the packaging shall be identified as described in the following lines. Shall be added also the specified safety warning statement.

Brand name: Telit

Model name: ME910G1-WW

Equipment name: WWAN module

NCC logo: 

NCC ID: CCAF20NB0050T0

NCC safety warning statement: “減少電磁波影響，請妥適使用”

NCC Note:

注意：行動電話業務(2G)於 106 年 6 月停止提供服務後，本設備 2G 功能在國內將無法使用。

13. PRODUCT AND SAFETY INFORMATION

SPECIFICATIONS ARE SUBJECT TO CHANGE WITHOUT NOTICE

13.1. Copyrights and Other Notices

Although reasonable efforts have been made to ensure the accuracy of this document, Telit assumes no liability resulting from any inaccuracies or omissions in this document, or from the use of the information contained herein. The information in this document has been carefully checked and is believed to be reliable. Telit reserves the right to make changes to any of the products described herein, to revise it and to make changes from time to time with no obligation to notify anyone of such revisions or changes. Telit does not assume any liability arising from the application or use of any product, software, or circuit described herein; neither does it convey license under its patent rights or the rights of others.

This document may contain references or information about Telit's products (machines and programs), or services that are not announced in your country. Such references or information do not necessarily mean that Telit intends to announce such Telit products, programming, or services in your country.

13.1.1. Copyrights

This instruction manual and the Telit products described herein may include or describe Telit's copyrighted material, such as computer programs stored in semiconductor memories or other media. Laws in Italy and in other countries reserve to Telit and its licensors certain exclusive rights for copyrighted material, including the exclusive right to copy, reproduce in any form, distribute and make derivative works of the copyrighted material. Accordingly, any of Telit's or its licensors' copyrighted material contained herein or described in this instruction manual, shall not be copied, reproduced, distributed, merged or modified in any manner without the express written permission of the owner. Furthermore, the purchase of Telit's products shall not be deemed to grant in any way, neither directly nor by implication, or estoppel, any license.

13.1.2. Computer Software Copyrights

Telit and the 3rd Party supplied Software (SW) products, described in this instruction manual may include Telit's and other 3rd Party's copyrighted computer programs stored in semiconductor memories or other media. Laws in Italy and in other countries reserve to Telit and other 3rd Party SW exclusive rights for copyrighted computer programs,

including – but not limited to - the exclusive right to copy or reproduce in any form the copyrighted products. Accordingly, any copyrighted computer programs contained in Telit's products described in this instruction manual shall not be copied (reverse engineered) or reproduced in any manner without the express written permission of the copyright owner, being Telit or the 3rd Party software supplier. Furthermore, the purchase of Telit products shall not be deemed to grant either directly or by implication, estoppel, or in any other way, any license under the copyrights, patents or patent applications of Telit or other 3rd Party supplied SW, except for the normal non-exclusive, royalty free license to use arising by operation of law in the sale of a product.

13.2. Usage and Disclosure Restrictions

13.2.1. License Agreements

The software described in this document is owned by Telit and its licensors. It is furnished by express license agreement only and shall be used exclusively in accordance with the terms of such agreement.

13.2.2. Copyrighted Materials

The Software and the documentation are copyrighted materials. Making unauthorized copies is prohibited by the law. The software or the documentation shall not be reproduced, transmitted, transcribed, even partially, nor stored in a retrieval system, nor translated into any language or computer language, in any form or by any means, without prior written permission of Telit.

13.2.3. High Risk Materials

Components, units, or third-party goods used in the making of the product described herein are NOT fault-tolerant and are NOT designed, manufactured, or intended for use as on-line control equipment in the following hazardous environments requiring fail-safe controls: operations of Nuclear Facilities, Aircraft Navigation or Aircraft Communication Systems, Air Traffic Control, Life Support, or Weapons Systems ("High Risk Activities"). Telit and its supplier(s) specifically disclaim any expressed or implied warranty of fitness eligibility for such High Risk Activities.

13.2.4. Trademarks

TELIT and the Stylized T-Logo are registered in the Trademark Office. All other product or service names are property of their respective owners.

13.2.5. 3rd Party Rights

The software may include 3rd Party's software Rights. In this case the user agrees to comply with all terms and conditions imposed in respect of such separate software rights. In addition to 3rd Party Terms, the disclaimer of warranty and limitation of liability provisions in this License, shall apply to the 3rd Party Rights software as well.

TELIT HEREBY DISCLAIMS ANY AND ALL WARRANTIES EXPRESSED OR IMPLIED FROM ANY 3RD PARTY REGARDING ANY SEPARATE FILES, ANY 3RD PARTY MATERIALS INCLUDED IN THE SOFTWARE, ANY 3RD PARTY MATERIALS FROM WHICH THE SOFTWARE IS DERIVED (COLLECTIVELY "OTHER CODES"), AND THE USE OF ANY OR ALL OTHER CODES IN CONNECTION WITH THE SOFTWARE, INCLUDING (WITHOUT LIMITATION) ANY WARRANTIES OF SATISFACTORY QUALITY OR FITNESS FOR A PARTICULAR PURPOSE.

NO 3RD PARTY LICENSORS OF OTHER CODES MUST BE LIABLE FOR ANY DIRECT, INDIRECT, INCIDENTAL, SPECIAL, EXEMPLARY, OR CONSEQUENTIAL DAMAGES (INCLUDING WITHOUT LIMITATION LOST OF PROFITS), HOWEVER CAUSED AND WHETHER MADE UNDER CONTRACT, TORT OR OTHER LEGAL THEORY, ARISING IN ANY WAY OUT OF THE USE OR DISTRIBUTION OF THE OTHER CODES OR THE EXERCISE OF ANY RIGHTS GRANTED UNDER EITHER OR BOTH THIS LICENSE AND THE LEGAL TERMS APPLICABLE TO ANY SEPARATE FILES, EVEN IF ADVISED OF THE POSSIBILITY OF SUCH DAMAGES.

13.2.6. Waiver of Liability

IN NO EVENT WILL TELIT AND ITS AFFILIATES BE LIABLE FOR ANY DIRECT, INDIRECT, SPECIAL, GENERAL, INCIDENTAL, CONSEQUENTIAL, PUNITIVE OR EXEMPLARY INDIRECT DAMAGE OF ANY KIND WHATSOEVER, INCLUDING BUT NOT LIMITED TO REIMBURSEMENT OF COSTS, COMPENSATION OF ANY DAMAGE, LOSS OF PRODUCTION, LOSS OF PROFIT, LOSS OF USE, LOSS OF BUSINESS, LOSS OF DATA OR REVENUE, WHETHER OR NOT THE POSSIBILITY OF SUCH DAMAGES COULD HAVE BEEN REASONABLY FORESEEN, CONNECTED IN ANY WAY TO THE USE OF THE PRODUCT/S OR TO THE INFORMATION CONTAINED IN THE PRESENT DOCUMENTATION, EVEN IF TELIT AND/OR ITS AFFILIATES HAVE BEEN ADVISED OF THE POSSIBILITY OF SUCH DAMAGES OR THEY ARE FORESEEABLE OR FOR CLAIMS BY ANY THIRD PARTY.

13.3. Safety Recommendations

Make sure the use of this product is allowed in your country and in the environment required. The use of this product may be dangerous and has to be avoided in areas where:

- it can interfere with other electronic devices, particularly in environments such as hospitals, airports, aircrafts, etc.
- there is a risk of explosion such as gasoline stations, oil refineries, etc. It is the responsibility of the user to enforce the country regulation and the specific environment regulation.

Do not disassemble the product; any mark of tampering will compromise the warranty validity. We recommend following the instructions of the hardware user guides for correct wiring of the product. The product has to be supplied with a stabilized voltage source and the wiring has to be conformed to the security and fire prevention regulations. The product has to be handled with care, avoiding any contact with the pins because electrostatic discharges may damage the product itself. Same cautions have to be taken for the SIM, checking carefully the instruction for its use. Do not insert or remove the SIM when the product is in power saving mode.

The system integrator is responsible for the functioning of the final product. Therefore, the external components of the module, as well as any project or installation issue, have to be handled with care. Any interference may cause the risk of disturbing the GSM network or external devices or having an impact on the security system. Should there be any doubt, please refer to the technical documentation and the regulations in force. Every module has to be equipped with a proper antenna with specific characteristics. The antenna has to be installed carefully in order to avoid any interference with other electronic devices and has to guarantee a minimum distance from the body (20 cm). In case this requirement cannot be satisfied, the system integrator has to assess the final product against the SAR regulation.

The equipment is intended to be installed in a restricted area location.

The equipment must be supplied by an external specific limited power source in compliance with the standard EN 62368-1:2014.

The European Community provides some Directives for the electronic equipment introduced on the market. All of the relevant information is available on the European Community website:

https://ec.europa.eu/growth/sectors/electrical-engineering_en

14. GLOSSARY

ADC	Analog – Digital Converter
CLK	Clock
CMOS	Complementary Metal – Oxide Semiconductor
CS	Chip Select
DAC	Digital – Analog Converter
DTE	Data Terminal Equipment
ESR	Equivalent Series Resistance
GPIO	General Purpose Input Output
HS	High Speed
HSDPA	High Speed Downlink Packet Access
HSIC	High Speed Inter Chip
HSUPA	High Speed Uplink Packet Access
I/O	Input Output
MISO	Master Input – Slave Output
MOSI	Master Output – Slave Input
PCB	Printed Circuit Board
RTC	Real Time Clock
SIM	Subscriber Identification Module
SPI	Serial Peripheral Interface
TTSC	Telit Technical Support Centre
UART	Universal Asynchronous Receiver Transmitter
UMTS	Universal Mobile Telecommunication System
USB	Universal Serial Bus
VNA	Vector Network Analyzer
VSWR	Voltage Standing Wave Ratio
WCDMA	Wideband Code Division Multiple Access

15. DOCUMENT HISTORY

Revision	Date	Changes
7	2021-02-02	<p>Reviewed template design and styles</p> <p>Section 2.4, update</p> <p>Chapter 4, update</p> <p>Sections 6.1, 6.2, 6.3, removed (redundant)</p> <p>Section 7.2, removed</p> <p>Section 8.4, measurements update</p> <p>Section 2.2, 2.5, 12.3, adding B86 update</p>
6	2020-09-14	<p>Section 2.5, TX Power update</p> <p>Section 2.8, Temperature range update</p> <p>Chapter 12, Conformity assessment update</p>
5	2020-07-22	Conformity assessment update with ANATEL
4	2020-06-18	<p>The title of chapter 5.7.3.2 has been changed from "Modem serial port 2" in "Modem serial port 2 (USIF1)".</p> <p>The title of chapter 5.7.3.1 has been changed from "Modem serial port 1" in "Modem serial port 1 (USIF0)".</p> <p>In the table of chapter 3.1, the "Asynchronous serial port" section title has been changed in "Asynchronous serial port (USIF0)".</p>
3	2020-06-10	<p>Conformity assessment update</p> <p>TX Output Power update</p> <p>Power Consumption section update</p> <p>GNSS Section update</p> <p>Applicability table update</p>
2	2020-01-23	<p>Conformity assessment update</p> <p>Power consumption figures update</p> <p>RX Sensitivity figures update</p> <p>RF Section update</p> <p>Pull-up/down values update</p>
1	2019-08-29	<p>Bands support updating</p> <p>Added ME910G1-WW</p> <p>Temperature range update</p> <p>Added power consumption figures</p> <p>Removed B14</p> <p>Extended Voltage Range lower limit change</p>
0	2019-04-12	First issue





Connect to our site and contact our technical support team for any question

www.telit.com



Telit

Telit reserves all rights to this document and the information contained herein. Products, names, logos and designs described herein may in whole or in part be subject to intellectual property rights. The information contained herein is provided "as is". No warranty of any kind, either express or implied, is made in relation to the accuracy, reliability, fitness for a particular purpose or content of this document. This document may be revised by Telit at any time. For most recent documents, please visit www.telit.com

Copyright © 2020, Telit