



DRAFT

Telit

ME310G1

HW Design Guide

1W0301588 Rev. 17 – 2021-11-17

APPLICABILITY TABLE

PRODUCTS
ME310G1-W1
ME310G1-WW
ME310G1-WWV
ME310G1-W2
ME310G1-W3

CONTENTS

APPLICABILITY TABLE	2
CONTENTS 3	
1 INTRODUCTION	9
1.1 Scope	9
1.2 Audience	9
1.3 Contact Information, Support	9
1.4 Symbol Conventions	10
1.5 Related Documents	10
2 GENERAL PRODUCT DESCRIPTION	11
2.1 Overview	11
2.2 Product Variants and Frequency Bands	11
2.3 Target Market	12
2.4 Main Features	13
2.5 TX Output Power	13
2.5.1 ME310G1-W1	13
2.5.2 ME310G1-WW	13
2.5.3 ME310G1-WWV	14
2.5.4 ME310G1-W2	14
2.5.5 ME310G1-W3	14
2.6 RX Sensitivity	15
2.6.1 ME310G1-W1	15
2.6.2 ME310G1-WW	16
2.6.3 ME310G1-W2	17
2.6.4 ME310G1-W3	18
2.7 Mechanical Specifications	19
2.7.1 Dimensions	19
2.7.2 Weight	19
2.8 Temperature Range	19
3 PINS ALLOCATION	21
3.1 Pin-out	21

3.2	LGA Pads Layout	26
4	POWER SUPPLY	27
4.1	Power Supply Requirements	27
4.2	Power Consumption	28
4.2.1	Idle Mode	28
4.2.2	ME310G1-W1 Connected Mode	29
4.2.3	ME310G1-WW and ME310G1-WWV Connected Mode	29
4.2.4	ME310G1-W2 Connected Mode	30
4.2.5	ME310G1-W3 Connected Mode	31
4.3	General Design Rules	31
4.3.1	Electrical Design Guidelines	31
4.3.1.1	+5V Source Power Supply Design Guidelines	31
4.3.1.2	+12V Source Power Supply Design Guidelines	32
4.3.1.3	Battery Source Power Supply Design Guidelines	33
4.3.2	Thermal Design Guidelines	33
4.3.3	Power Supply PCB Layout Guidelines	34
4.4	RTC Supply	35
4.5	PWRMON Power-on Monitor	35
5	DIGITAL SECTION	37
5.1	Logic Levels	37
5.2	Power On	38
5.3	Power Off	39
5.4	Unconditional Shutdown	40
5.5	Wake up From Deep Sleep Mode	41
5.6	Fast Shut Down	41
5.6.1	Fast Shut Down by Hardware	41
5.6.2	Fast Shut Down by Software	42
5.7	Communication Ports	42
5.7.1	USB 2.0 HS	42
5.7.2	SPI	43
5.7.3	Serial Ports	43
5.7.3.1.	Asynchronous Serial Port (USIF0)	44

5.7.3.1	Asynchronous Serial Port (USIF1)	45
5.7.3.2	Auxiliary Serial Port	45
5.8	General Purpose I/O	46
5.8.1	Using a GPIO as INPUT	46
5.8.2	Using a GPIO as OUTPUT	47
5.9	External SIM Holder	47
5.10	ADC Converter	47
5.10.1	Using ADC Converter	48
5.11	DAC Converter	48
5.11.1	Enabling DAC	48
5.12	CTANK	48
5.13	Forced USB Boot	48
5.14	Antenna Tuner	49
5.14.1	GPIO	49
5.14.2	MIPI	49
6	RF SECTION	50
6.1	Antenna Requirements	50
6.1.1	PCB Design Guidelines	51
6.1.2	PCB Guidelines in Case of FCC Certification	52
6.1.2.1	Transmission Line Design	53
6.1.2.2	Transmission Line Measurements	53
6.1.2.3	Antenna Installation Guidelines	55
7	AUDIO SECTION	57
7.1	Electrical Characteristics	57
8	GNSS SECTION	58
8.1	GNSS Signals Pin-out	58
8.2	RF Front End Design	58
8.2.1	PCB Guidelines for GNSS Antenna	58
8.2.2	Hardware-based Solution for GNSS and LTE Coexistence	59
8.3	GNSS Antenna Requirements	59
8.3.1	GNSS Antenna Specification	60

8.3.2	GNSS Antenna – Installation Guidelines	60
8.3.3	Powering the External LNA (Active Antenna)	60
8.4	GNSS Characteristics	61
9	MECHANICAL DESIGN	62
9.1	Drawing	62
9.1.1	ME310G1-W1	62
9.1.2	ME310G1-WW, ME310G1-WWV, ME310G1-W2, and ME310G1-W3	63
10	APPLICATION PCB DESIGN	64
10.1	Footprint	64
10.1.1	ME310G1-W1	64
10.1.2	ME310G1-WW, ME310G1-WWV, ME310G1-W2, and ME310G1-W3	66
10.1.3	Recommendations for ME310G1-W1	68
10.1.4	Recommendations for ME310G1-WW, ME310G1-WWV, ME310G1-W2, and ME310G1-W3	69
10.2	PCB Pad Design	70
10.3	Stencil	70
10.4	Solder Paste	71
10.5	Solder Reflow	71
11	PACKAGING	73
11.1	Tray	73
11.1.1	ME310G1-W1	73
11.1.2	ME310G1-WW, ME310G1-W2, and ME310G1-W3	75
11.2	Reel	77
11.2.1	ME310G1-W1	77
11.2.2	ME310G1-WW, ME310G1-W2, and ME310G1-W3	78
11.3	Moisture Sensitivity	79
12	CONFORMITY ASSESSMENT ISSUES	80
12.1	Approvals Summary	80
12.2	Europe Approvals	80
12.2.1	RED Declaration of Conformity	80

12.2.2	UKCA Declaration of Conformity	80
12.2.3	RED/UKCA Antennas	81
12.3	FCC and ISED Approval/ <i>FCC et ISDE Approbation</i>	81
12.3.1	FCC Certificates	81
12.3.2	ISED Certificate / <i>ISDE Certificates</i>	82
12.3.3	Applicable FCC and ISED Rules / <i>Liste des Règles FCC et ISDE Applicables</i>	82
12.3.4	FCC and ISED Regulatory Notices/ <i>Avis Réglementaires de FCC et ISDE</i>	82
12.3.5	FCC/ISED Antennas / <i>FCC/ISDE Antennes</i>	83
12.3.6	FCC label and Compliance Information	85
12.3.7	ISED Label and Compliance Information/ <i>Étiquette et Informations de Conformité ISDE</i>	86
12.3.8	Information on Test Modes and Additional Testing Requirements/ <i>Informations sur les Modes de Test et les Exigences de Test Supplémentaires</i>	87
12.3.9	FCC Additional Testing, Part 15 Subpart B Disclaimer	87
12.4	ANATEL Regulatory Notices	88
12.5	NCC Regulatory Notices	88
12.6	JRL/JTBL Regulatory Notices	88
13	PRODUCT AND SAFETY INFORMATION	89
13.1	Copyrights and Other Notices	89
13.1.1	Copyrights	89
13.1.2	Computer Software Copyrights	89
13.2	Usage and Disclosure Restrictions	90
13.2.1	License Agreements	90
13.2.2	Copyrighted Materials	90
13.2.3	High-Risk Materials	90
13.2.4	Trademarks	91
13.2.5	Third Party Rights	91
13.2.6	Waiver of Liability	91
13.3	Safety Recommendations	92
14	GLOSSARY	93

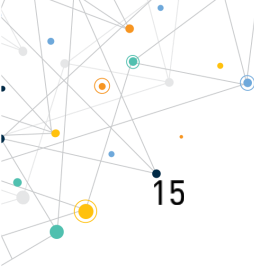

1 INTRODUCTION

1.1 Scope

This document describes the electrical specifications, mechanical information, interface application, and manufacturing information of the Telit ME310G1 module. With the help of this document and other application notes or user guides, users can understand the Telit ME310G1 module well and quickly develop various products.

1.2 Audience

This document is intended for system integrators who use the Telit ME310G1 module in their products.

1.3 Contact Information, Support

For technical queries, support services, and to share documentation feedback, contact Telit Technical Support at:

- TS-EMEA@telit.com
- TS-AMERICAS@telit.com
- TS-APAC@telit.com
- TS-SRD@telit.com
- TS-ONEEDGE@telit.com

Alternatively, you may visit

<https://www.telit.com/contact-us/>

For more information about Telit modules, visit

<https://www.telit.com>

1.4 Symbol Conventions



Danger: This information **MUST** be followed, or catastrophic equipment failure or personal injury may occur.



Warning: Alerts the user on important steps about the module integration.



Note/Tip: Provides advice and suggestions that may be useful when integrating the module.



Electro-static Discharge: Notifies the user to take proper grounding precautions before handling the product.

Table 1: Symbol Conventions

All dates are in ISO 8601 format, that is YYYY-MM-DD.

1.5 Related Documents

- 80617ST10991AME310G1/ME910G1/ML865G1 AT Commands Reference Guide
- 80529NT11661ACat M/NB-IoT Quick Start Guide
- 1VW0300989SSL/TLS User Guide
- 80000NT10001ASIM Integration Design Guide
- 80000NT10060AxE910 Global Form Factor Application Note
- 80000NT10002AAntenna Detection Application Note
- 80000NT10003ARework procedure for BGA modules
- 80000NT10028AEvent Monitor Application Note

2 GENERAL PRODUCT DESCRIPTION

2.1 Overview

The Telit ME310G1 module is a CATM / NBIoT communication module that allows integrators to plan availability for lifecycle applications.

The Telit ME310G1-WWV module is fully voice capable with a Digital Voice Interface (DVI). It is suitable for applications such as voice-enabled alarm panels, mHealth patient monitors, and special devices used by elderly or disabled.

The Telit ME310G1 module operates with 1.8 V GPIOs, minimizing power consumption. This makes it suitable for battery-powered and wearable devices.

2.2 Product Variants and Frequency Bands

Product	HW Rev	2G Band (MHz)	LTE CATM1	NB IoT	CS Voice VoLTE	External Antenna Tuner Support	Region
ME310G1-W1	0.0	-	B1, B2, B3, B4, B5, B8, B12, B13, B18, B19, B20, B25, B26, B27, B28, B66, B85, B8_39d*	B1, B2, B3, B4, B5, B8, B12, B13, B18, B19, B20, B25, B26, B28, B66, B71, B85, B86*, B8_39d*	N	Y	Worldwide
ME310G1-WW	0.0	850, 900, 1800, 1900	B1, B2, B3, B4, B5, B8, B12, B13, B18, B19, B20, B25, B26, B27, B28, B66, B85, B8_39d*	B1, B2, B3, B4, B5, B8, B12, B13, B18, B19, B20, B25, B26, B28, B66, B71, B85, B8_39d*	N	N	Worldwide
	1.0					Y	
ME310G1-WWV	1.0	850, 900, 1800, 1900	B1, B2, B3, B4, B5, B8, B12, B13, B18, B19, B20, B25, B26, B27, B28, B66, B85	-	Y	Y	Worldwide
ME310G1-W2	0.0	-	B1, B3, B8, B20, B28, B31, B72	B1, B3, B8, B20, B28, B31, B72	N	N	Worldwide
ME310G1-W3	0.0		B1, B2, B3**, B4, B5**, B8, B12, B13, B14, B18, B19, B20, B25, B26**, B27, B28, B66, B85, B8_39d*		N	N	Worldwide

Table 2: Product Variants and Frequency Band

* and ** See notes below

For more information about frequencies, see [RF Section](#).



Note: Cellular technologies and frequency bands may vary based on firmware version and firmware configuration used.



Note: “B86” is not a 3GPP band, it means the following:

UL range: 787-788 MHz, DL range: 757-758 MHz that is available only in module where AT#BNDOPTIONS command contains the string B86. that is AT#BNDOPTIONS?

#BNDOPTIONS: 1,2,3,4,5,8,12,13,18,19,20,25,26,27,28,66,71,85,86.



Note: “B8_39d” is not a 3GPP band, it means the following:

U.S. FCC 900MHz that employs 39MHz duplexing

UL range: 897.5-900.5MHz, DL range: 936.5-939.5

It is available only in the module where AT#BNDOPTIONS command contains the string B8_39d. that is AT#BNDOPTIONS?

#BNDOPTIONS: 1,2,3,4,5,8,12,13,18,19,20,25,26,27,28,66,71,85, B8_39d.



Note: ** indicates SKT bands.

2.3 Target Market

The Telit ME310G1 can be used for telematics applications where tamper-resistance, confidentiality, integrity, and authenticity of end-user information are required, for example:

- Telematics services
- Road pricing
- Pay-as-you-drive insurance
- Vehicles tracking
- Internet connectivity

2.4 Main Features

Function*	Features
Modem	<ul style="list-style-type: none"> CATM and NBloT technologies SMS support (text and PDU) Alarm management Real-Time Clock
Interfaces	<ul style="list-style-type: none"> USB 2.0 HS (AT command* and FW upgrade) USIF0 Main UART (AT command* and FW upgrade) USIF1 Secondary UART (Not currently supported) AUX UART (AT Command*, AppZone Diagnostic) SPI 6 GPIOs Antenna port

Table 3: Functional Features

* Functionality depending on ports configuration

2.5 TX Output Power

2.5.1 ME310G1-W1

Band	Mode	Class	RF power (dBm) Nominal*
B1, B2, B3, B4, B5, B8, B12, B13, B14, B18, B19, B20, B25, B26, B27, B28, B66, B85, B8_39d	(LTE) CAT-M1	5	21
B1, B2, B3, B4, B5, B8, B12, B13, B18, B19, B20, B25, B26, B28, B66, B71, B85, B86, B8_39d	(LTE) CAT-NB1	5	21

Table 4: Transmission Output Power ME310G1W1

2.5.2 ME310G1-WW

Band	Mode	Class	RF power (dBm) Nominal*
850/ 900MHz	GPRS	4	32.5
	EGPRS	E2	27
1800/ 1900MHz	GPRS	1	29.5
	EGPRS	E2	26
B1, B2, B3, B4, B5, B8, B12, B13, B18, B19, B20, B25, B26, B27, B28, B66, B85, B8_39d	(LTE) CAT-M1	3	23
B1, B2, B3, B4, B5, B8, B12, B13, B18, B19, B20, B25, B26, B28, B66, B85, B86, B8_39d	(LTE) CAT-NB2	3	23
B71	(LTE) CAT-NB2	5	20

Table 5: Transmission Output Power ME310G1-WW

2.5.3 ME310G1-WWV

Band	Mode	Class	RF power (dBm) Nominal*
850/900MHz	GPRS	4	32.5
	EGPRS	E2	27
1800/1900MHz	GPRS	1	29.5
	EGPRS	E2	26
B1, B2, B3, B4, B5, B8, B12, B13, B18, B19, B20, B25, B26, B27, B28, B66, B85	(LTE) CAT-M1	3	23
B1, B2, B3, B4, B5, B8, B12, B13, B18, B19, B20, B25, B26, B28, B66, B85	(LTE) CAT-NB2	3	23
B71	(LTE) CAT-NB2	5	20

Table 6: Transmission Output Power ME310G1-WWV

2.5.4 ME310G1-W2

Band	Mode	Class	RF power (dBm) Nominal*
B1, B3, B8, B20, B28	(LTE) CAT-M1	5	21
B1, B3, B8, B20, B28	(LTE) CAT-NB2	5	21
B31, B72	(LTE) CAT-M1	2	26
B31, B72	(LTE) CAT-NB2	3	23

Table 7: Transmission Output Power ME310G1-W2

* Max output power tolerance range according to 3GPP TS 36.521-1 and 3GPP TS 51.010-1 or higher

2.5.5 ME310G1-W3

Band	Mode	Class	RF power (dBm) Nominal*
B1, B2, B3**, B4, B5**, B8, B12, B13, B14, B18, B19, B20, B25, B26**, B27, B28, B66, B85, B8_39d	(LTE) CAT-M1	3	23

Table 8: Transmission Output Power ME310G1-W3

* Max output power tolerance range according to 3GPP TS 36.521-1 and 3GPP TS 51.010-1 or higher

** indicates SKT bands

2.6 RX Sensitivity

2.6.1 ME310G1-W1

Band	REFsens (dBm) Typical	REFsens (dBm)* 3GPP Limit
CATM1 / Band1	-107.1	-102.7
CAT M1 / Band2	-107.5	-100.3
CAT M1 / Band3	-106.4	-99.3
CAT M1 / Band4	-107.3	-102.3
CAT M1 / Band5	-106.0	-100.8
CAT M1 / Band8	-107.3	-99.8
CAT M1 / Band12	-103.2	-99.3
CAT M1 / Band13	-104.3	-99.3
CAT M1 / Band18	-107.2	-102.3
CAT M1 / Band19	-106.5	-102.3
CAT M1 / Band20	-105.4	-99.8
CAT M1 / Band25	-107.5	-
CAT M1 / Band26	-107.1	-100.3
CAT M1 / Band27	-107.1	-100.8
CAT M1 / Band28	-105.5	-100.8
CAT M1 / Band66	-107.5	-
CAT M1 / Band85	-102.2	-
CAT NB2 / Band1	-115.5	-108.2
CAT NB2 / Band2	-115.6	-108.2
CAT NB2 / Band3	-114.0	-108.2
CAT NB2 / Band4	-115.8	-
CAT NB2 / Band5	-115.1	-108.2
CAT NB2 / Band8	-114.1	-108.2
CAT NB2 / Band12	-115.5	-108.2
CAT NB2 / Band13	-115.8	-108.2

Band	REFsens (dBm) Typical	REFsens (dBm)* 3GPP Limit
CAT NB2 / Band18	-115.1	-108.2
CAT NB2 / Band19	-115.4	-108.2
CAT NB2 / Band20	-114.0	-108.2
CAT NB2 / Band25	-115.7	-
CAT NB2 / Band26	-115.4	-108.2
CAT NB2 / Band28	-115.7	-108.2
CAT NB2 / Band66	-115.3	-108.2
CAT NB2 / Band71	-111.3	-
CAT NB2 / Band85	-115.7	-

Table 9: RX Sensitivity ME310G1-W1

* 3GPP TS 36.521-1 release 15 minimum performance requirement

2.6.2 ME310G1-WW

Band	REFsens (dBm) Typical	REFsens (dBm)* 3GPP Limit
CATM1 / Band1	-105.6	-102.7
CAT M1 / Band2	-106.7	-100.3
CAT M1 / Band3	-104.3	-99.3
CAT M1 / Band4	-106.2	-102.3
CAT M1 / Band5	-105.8	-100.8
CAT M1 / Band8	-106.2	-99.8
CAT M1 / Band12	-104.8	-99.3
CAT M1 / Band13	-106.7	-99.3
CAT M1 / Band18	-106.6	-102.3
CAT M1 / Band19	-105.7	-102.3
CAT M1 / Band20	-105.7	-99.8
CAT M1 / Band25	-106.7	-
CAT M1 / Band26	-106.4	-100.3
CAT M1 / Band27	-106.9	-100.8
CAT M1 / Band28	-106.4	-100.8

Band	REFsens (dBm) Typical	REFsens (dBm)* 3GPP Limit
CAT M1 / Band66	-105.8	-
CAT M1 / Band85	-104.0	-
CAT NB2 / Band1	-115.7	-108.2
CAT NB2 / Band2	-115.9	-108.2
CAT NB2 / Band3	-115.5	-108.2
CAT NB2 / Band4	-115.1	-
CAT NB2 / Band5	-115.8	-108.2
CAT NB2 / Band8	-115.3	-108.2
CAT NB2 / Band12	-115.5	-108.2
CAT NB2 / Band13	-115.5	-108.2
CAT NB2 / Band18	-115.8	-108.2
CAT NB2 / Band19	-115.6	-108.2
CAT NB2 / Band20	-114.7	-108.2
CAT NB2 / Band25	-115.9	-
CAT NB2 / Band26	-115.7	-108.2
CAT NB2 / Band28	-115.5	-108.2
CAT NB2 / Band66	-115.2	-108.2
CAT NB2 / Band71	-107.5	-
CAT NB2 / Band85	-115.5	-
GPRS/GSM850	TBD	-104
GPRS/GSM900	TBD	-104
GPRS/DCS1800	TBD	-104
GPRS/PCS1900	TBD	-104

Table 10: RX Sensitivity ME310G1-WW

* 3GPP TS 36.521-1 release 15 minimum performance requirement

2.6.3 ME310G1-W2

Band	REFsens (dBm) Typical	REFsens (dBm)* 3GPP Limit
CATM1 / Band1	-106.6	-102.7

Band	REFsens (dBm) Typical	REFsens (dBm)* 3GPP Limit
CAT M1 / Band3	-107.0	-99.3
CAT M1 / Band8	-106.9	-99.8
CAT M1 / Band20	-106.8	-99.8
CAT M1 / Band28	-107.4	-100.8
CAT M1 / Band31	-105.2	-96.6
CAT M1 / Band72	-105.4	-96.6

Table 11: RX Sensitivity ME310G1-W2

* 3GPP TS 36.521-1 release 15 minimum performance requirement

2.6.4 ME310G1-W3

Band	REFsens (dBm) Typical	REFsens (dBm)* 3GPP Limit
CATM1 / Band1	-107.2	-102.3
CAT M1 / Band2	-107.3	-100.3
CAT M1 / Band3**	-106.8	-99.3
CAT M1 / Band4	-106.7	-102.3
CAT M1 / Band5**	-107.2	-100.8
CAT M1 / Band8	-107.1	-99.8
CAT M1 / Band12	-107.3	-99.3
CAT M1 / Band13	-107.7	-99.3
CAT M1 / Band14	-107.7	-99.3
CAT M1 / Band18	-107.5	-102.3
CAT M1 / Band19	-107.2	-102.3
CAT M1 / Band20	-106.9	-99.8
CAT M1 / Band25	-107.3	-100.3
CAT M1 / Band26**	-107.3	-100.3
CAT M1 / Band27	-107.2	-100.8
CAT M1 / Band28	-107.9	-100.8
CAT M1 / Band66	-107.2	-102.3

Band	REFsens (dBm) Typical	REFsens (dBm)* 3GPP Limit
CAT M1 / Band85	-107.4	-99.3
CAT M1 / Band8_39d	-108.1	-99.8

Table 12: RX Sensitivity ME310G1-W3

* 3GPP TS 36.521-1 release 15 minimum performance requirement

** indicates SKT bands

2.7 Mechanical Specifications

2.7.1 Dimensions

The overall dimensions of the ME310G1-W1 are:

- Length: 14.3 mm
- Width: 13.1 mm
- Thickness: 2.6 mm

The dimensions of the ME310G1-WW, ME310G1-WWV, ME310G1-W2, and ME310G1-W3 are:

- Length: 18.0 mm
- Width: 15.0 mm
- Thickness: 2.6 mm

2.7.2 Weight

The nominal weight of the ME310G1-W1 is 1 Gram.

The nominal weight of the ME310G1-WW, ME310G1-WWV, and ME310G1-W2 is 1.5 Gram.

2.8 Temperature Range

Temperature range		Note
Operating Temperature Range	-40°C to +85°C	The module is fully functional (*) and compliant according to regulatory standards.
Storage Temperature Range	-40°C to +105°C	The module is not powered and not connected to power supply

Table 13: Temperature Range



Note: (*) If applicable, the module can make and receive voice calls, data calls, send and receive SMS, and data traffic.

3 PINS ALLOCATION

3.1 Pin-out

Pin	Signal	I/O	Function	Type	Comment
USB HS 2.0 Communication Port					
U19	USB_D+	I/O	USB differential Data (+)		
V18	USB_D-	I/O	USB differential Data (-)		
T18	USB_VBUS	AI	USB Power Sense		
Asynchronous Serial Port (USIF0) – Prog. / Data + HW Flow Control					
Y16	TXD0	I	Serial data input (TXD) from DTE	CMOS 1.8V	Internal PU (100K)
AA15	RXD0	O	Serial data output (RXD) to DTE	CMOS 1.8V	
Y18	RTS0	I	Input for Request to send signal (RTS) from DTE	CMOS 1.8V	Internal PU (100K)
AA17	CTS0	O	Output for Clear to send signal (CTS) to DTE	CMOS 1.8V	
Asynchronous Serial Port (USIF1)					
Y12	TXD1	I	Serial data input (TXD) from DTE	CMOS 1.8V	Internal PU (100K)
AA11	RXD1	O	Serial data output (RXD) to DTE	CMOS 1.8V	MUST NOT BE "HIGH" at boot
AA13	RTS1	I	Input for Request to send signal (RTS) from DTE	CMOS 1.8V	Internal PU (100K)
Y14	CTS1	O	Output for Clear to send signal (CTS) to DTE	CMOS 1.8V	
Auxiliary Serial Port					
Y10	TX_AUX	O	Auxiliary UART (TX Data to DTE)	CMOS 1.8V	
AA9	RX_AUX	I	Auxiliary UART (RX Data to DTE)	CMOS 1.8V	Internal PU (100K)
SIM card interface					
L1	SIM_CLK	O	External SIM signal – Clock	CMOS 1.8V	
M2	SIM_RST	O	External SIM signal – Reset	CMOS 1.8V	
N1	SIM_DAT	I/O	External SIM signal – Data I/O	CMOS 1.8V	

Pin	Signal	I/O	Function	Type	Comment
P2	SIM_VCC	-	Power supply for the SIM	1.8V	Only 1.8V simcard are supported
-	SIMIN	I	Presence SIM input	CMOS 1.8V	See par.5.8
SPI					
AA5	SPI_MOSI	I/O	SPI MOSI	CMOS 1.8V	
Y8	SPI_MISO	I/O	SPI MISO	CMOS 1.8V	
AA7	SPI_CLK	I/O	SPI Clock	CMOS 1.8V	
Y6	SPI_CS	I/O	SPI Chip Select	CMOS 1.8V	
DIGITAL IO					
V11	I01	I/O	Configurable GPIO01/ DTR is alternate function	CMOS 1.8V	Internal PU (100K) if DTR
V13	I02	I/O	Configurable GPIO02/ RING is alternate function	CMOS 1.8V	Internal PD (100K)
D7	I03	I/O	Configurable GPIO03	CMOS 1.8V	Internal PD (100K)
D9	I04	I/O	Configurable GPIO04	CMOS 1.8V	Internal PD (100K)
D11	I05	I/O	Configurable GPIO05	CMOS 1.8V	Internal PD (100K)
D13	I06	I/O	Configurable GPIO06	CMOS 1.8V	Internal PD (100K)
ADC and DAC					
B18	ADC	I	Analog To Digital converter Input	A/D	
R16	DAC	O	Digital To Analog converter Output	D/A	PWM signal
RF Section					
A5	CELL_MAIN ANTENNA	I/O	Main Antenna (50 ohm)	RF	
E19	GNSS ANTENNA	I	GNSS Antenna	RF	
GNSS_PPS					
H18	GNSS_LNA_EN	O	GNSS external LNA enable	CMOS 1.8V	
G16	GNSS_PPS	O	1 Pulse per Second	CMOS 1.8V	
Miscellaneous Functions					
B2	S_LED	O	Status LED	CMOS 1.8V	

Pin	Signal	I/O	Function	Type	Comment
N16	ON_OFF*/WAKE*	I	Input Command for Power ON/OFF and to wake from deep sleep mode	CMOS 1.8V	Active Low
R1	PWRMON	O	Power ON Monitor	CMOS 1.8V	
T2	FORCED_USB_BOOT	I	Optional pin, connect to test point	CMOS 1.8V	Active high, Internal PD (100K)
Audio Section					
C1	DVI_WA0	I/O	Digital Audio Interface (WA0)	CMOS 1.8V	
D2	DVI_RX	O	Digital Audio Interface (RX)	CMOS 1.8V	
E1	DVI_TX	I	Digital Audio Interface (TX)	CMOS 1.8V	
F2	DVI_CLK	I/O	Digital Audio Interface (CLK)	CMOS 1.8V	
Power Supply					
W1	VBATT_PA	-	Main power supply (Radio PA)	Power	
AA3	VBATT	-	Main power supply (Baseband)	Power	
N4	CTANK	-	Internal supply domain pin for external tank capacitor	1.8V	
Antenna Tuner Section (Only on HW1.0)					
G1	ATC1/MIPI_CLK	O	Antenna Tuner Ctrl		Only on HW1.0
J1	ATC2/MIPI_DATA	O	Antenna Tuner Ctrl		Only on HW1.0
H2	ATV	O	Antenna Tuner Voltage		Only on HW1.0
GND					
A3	GND	-	RF Ground	Power	
A7	GND	-	RF Ground	Power	
A9	GND	-	RF Ground	Power	
A13	GND	-	RF Ground	Power	
A17	GND	-	RF Ground	Power	
B4	GND	-	RF Ground	Power	
B6	GND	-	RF Ground	Power	
B10	GND	-	RF Ground	Power	
B12	GND	-	RF Ground	Power	
B14	GND	-	RF Ground	Power	
B16	GND	-	RF Ground	Power	
C19	GND	-	RF Ground	Power	

Pin	Signal	I/O	Function	Type	Comment
D18	GND	-	RF Ground	Power	
F8	GND	-	Thermal Ground	Power	
F12	GND	-	Thermal Ground	Power	
F18	GND	-	Thermal Ground	Power	
G19	GND	-	Thermal Ground	Power	
H6	GND	-	Thermal Ground	Power	
H14	GND	-	Thermal Ground	Power	
J19	GND	-	Thermal Ground	Power	
K18	GND	-	Thermal Ground	Power	
M18	GND	-	Thermal Ground	Power	
N19	GND	-	Thermal Ground	Power	
P6	GND	-	Thermal Ground	Power	
P14	GND	-	Thermal Ground	Power	
T8	GND	-	Thermal Ground	Power	
T12	GND	-	Thermal Ground	Power	
U1	GND	-	Power Ground	Power	
V2	GND	-	Power Ground	Power	
W19	GND	-	Power Ground	Power	
Y2	GND	-	Power Ground	Power	
Y4	GND	-	Power Ground	Power	
RESERVED					
G1	RESERVED	-	RESERVED		Only in HW 0.0
H2	RESERVED	-	RESERVED		Only in HW 0.0
J1	RESERVED	-	RESERVED		Only in HW 0.0
K2	RESERVED	-	RESERVED		
J4	RESERVED	-	RESERVED		
G4	RESERVED	-	RESERVED		
L19	RESERVED	-	RESERVED		
A11	RESERVED	-	RESERVED		
R4	RESERVED	-	RESERVED		
L4	RESERVED	-	RESERVED		

Pin	Signal	I/O	Function	Type	Comment
V7	RESERVED	-	RESERVED		
V9	RESERVED	-	RESERVED		
L16	RESERVED	-	RESERVED		
P18	RESERVED	-	RESERVED		
J16	RESERVED	-	RESERVED		
R19	RESERVED	-	RESERVED		
B8	RESERVED	-	RESERVED		
A15	RESERVED	-	RESERVED		

Table 14: Pin-out Information



Warning: Reserved pins must not be connected. All pull-up (PU) and pull-down (PD) are about 100K.



Warning: C104/RXD1 cannot have any PU or HIGH state during the BOOT UP phase.

3.2 LGA Pads Layout

TOP VIEW (HW 1.0)

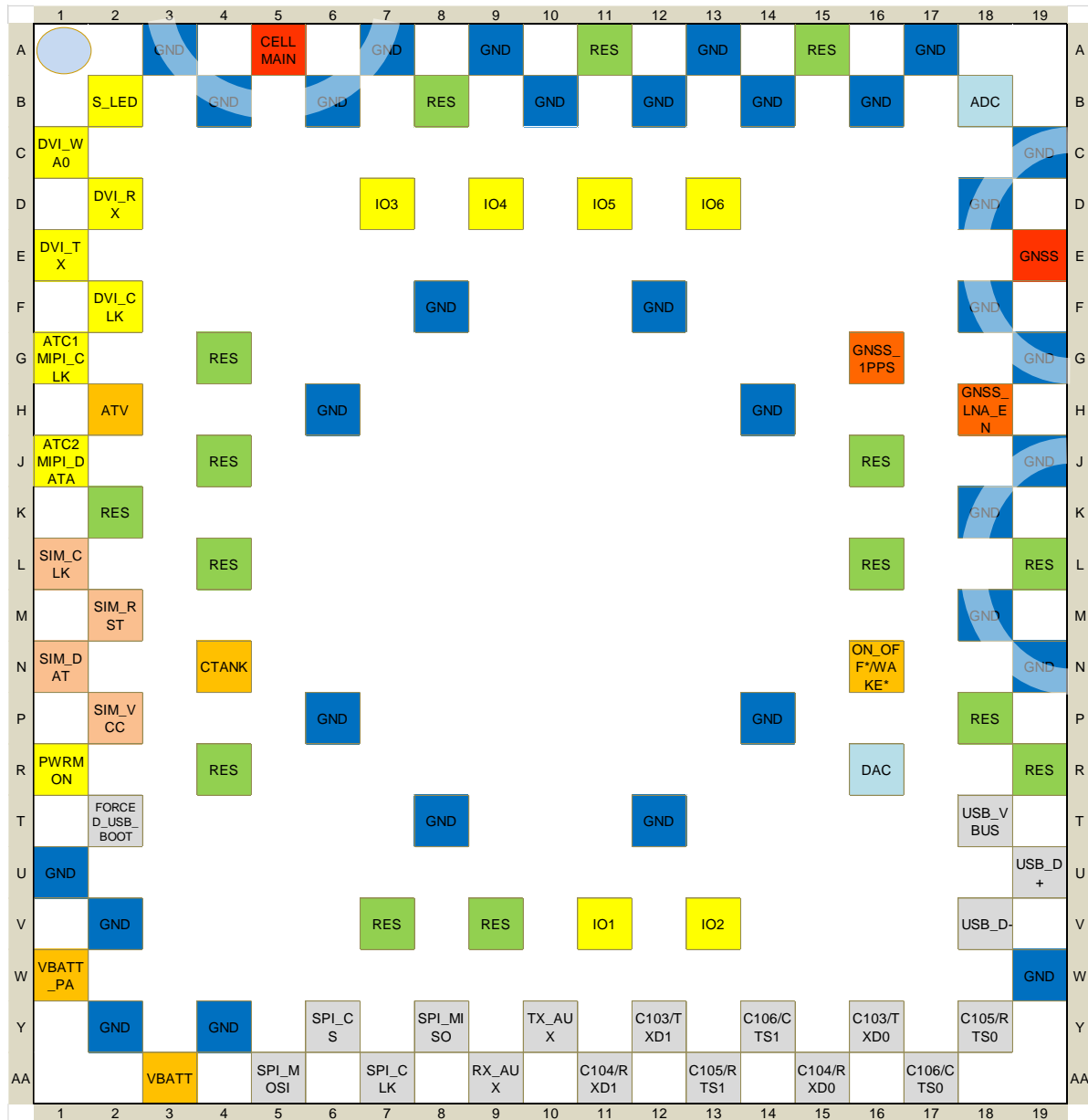

Figure 1: LGA Pads Layout

	SUPPLY AND CONTROL
	SIM CARD
	ANALOG FUNCTIONALITY
	GROUND
	DIGITAL FUNCTIONALITY
	DIGITAL COMMUNICATION
	RF SIGNALS
	RESERVED/NOT ASSIGNED/ RESERVED FOR FUTURE USE
	GNSS

Figure 2: LGA Pads Layout legends

4 POWER SUPPLY

The power supply circuit and board layout are an important part of the product design. Make sure to follow the guidelines and requirements for optimal performance.

4.1 Power Supply Requirements

The external power supply must be connected to the VBATT & VBATT_PA signals. The following are the power supply requirements:

Power Supply	Value
Nominal Supply Voltage	3.8V
Operating Voltage Range	3.2 V - 4.2 V
Extended Voltage Range	2.6 V - 4.5 V
VBATT _{min}	2.7V

Table 15: Power Supply Requirements



Warning: The range 2.6V - 3.2V can be used only if both USB and 2G are disabled.



Warning: The modem supply voltage must never exceed the Extended Operating Voltage Range. Inaccurate implementation of power supply guidelines can cause a faulty module.



Note: For PTCRB approval on the final product, the power supply must be within the **Operating Voltage Range**.



Note: The power supply section of the application must be carefully designed to avoid excessive voltage drop during peak transmission current absorptions. If the voltage drops beyond the limits of the Extended Operating Voltage range, an unintentional module power off can occur.



Note: At power on, the modem voltage must be at least VBATT_{min}.



Note: The Hardware User Guide specifications must be recognized and carefully implemented to use the module in its **Extended Operating Voltage Range**.

4.2 Power Consumption

4.2.1 Idle Mode

Mode	Measure (Typical)			Mode Description
	CATM (mA)	NB-IoT (mA)	2G (mA)	
IDLE mode				
AT+CFUN=1	8.1	8.0	8.0	Normal mode: full functionality of the module
AT+CFUN=4	7.5			Disabled TX and RX; module is not registered on the network
AT+CFUN=5	1.20	0.95	-	Paging cycle #256 frames (2.56s DRx cycle)
	0.60	0.60	-	81.92s eDRx cycle length (PTW=2.56s, DRX=1.28s)
	0.18 ¹	0.18 ¹	-	327.68s eDRx cycle length (PTW=2.56s, DRX=1.28s)
	0.10 ¹	0.10 ¹	-	655.36s eDRx cycle length (PTW=2.56s, DRX=1.28s)
	0.05 ¹	0.05 ¹	-	1310.72s eDRx cycle length (PTW=2.56s, DRX=1.28s)
	0.03 ¹	0.03 ¹	-	2621.44s eDRx cycle length (PTW=2.56s, DRX=1.28s)
	-	-	0.90	Paging Multiframe 9
PSM mode	Typical (mA)			
AT+CPSMS=1	3uA			No current source or sink by any connected pin

Table 16: Idle and PSM mode

¹PSM in between eDRX

Mode		Measure* (Typical)	Mode Description
GPS		(mA)	
Active State (GNSS ON, CFUN=4)	Acquisition	69.3	GPS+GLO, DPO off
	Navigation	22	GPS+GLO, DPO on DWELL=280ms
		55.9	GPS+GLO, DPO off
Active State (GNSS ON, CFUN=5 eDRX)	Acquisition	68.5	GPS+GLO, DPO off
	Navigation	15.7	GPS+GLO, DPO on DWELL=280ms

Mode		Measure* (Typical)	Mode Description
GPS		(mA)	
		54	GPS+GLO, DPO off

Table 17: GPS Mode

*Reference signal @-130 dBm with static scenario



Note: The reported LTE CAT M1 and LTE CAT NB1 idle mode values are an average among all product variants and bands for each network wireless technology. Support for a specific network wireless technology depends on the product variant configuration.

4.2.2 ME310G1-W1 Connected Mode

Mode	Measure (Typical)		Mode Description
	Average (mA)	Peak (mA)	
Connected mode			
CATM	180	400	1 RB, RMC, TBS=5, QPSK, 21dBm, all bands
NBloT	245	340	3.75KHz subcarrier spacing, 1 SC, RU 32ms, TBS=0, BPSK, 21dBm, all bands
	65	290	15KHz subcarrier spacing, 12 SC, RU 1ms, TBS=5, QPSK, 21dBm, all bands

Table 18: ME310G1-W1 connected mode

4.2.3 ME310G1-WW and ME310G1-WWV Connected Mode

Mode	Measure (Typical)		Mode Description
	Average (mA)	Peak (mA)	
Connected mode			
CATM	380	1100	1 RB, RMC, TBS=5, QPSK, 23dBm, Band 85, 28, 12
	320	900	1 RB, RMC, TBS=5, QPSK, 23dBm, Band 13, 26, 5, 18, 19, 20, 8
	305	800	1 RB, RMC, TBS=5, QPSK, 23dBm, Band 3, 2, 25, 4, 1, 66
NBloT	240	335	3.75KHz subcarrier spacing, 1 SC, RU 32ms, TBS=0, BPSK, 20dBm, Band 71

Connected mode	Measure (Typical)		Mode Description
	Average (mA)	Peak (mA)	
NBloT	600	1000	3.75KHz subcarrier spacing, 1 SC, RU 32ms, TBS=0, BPSK, 23dBm, Band 85, 28, 12
	500	850	3.75KHz subcarrier spacing, 1 SC, RU 32ms, TBS=0, BPSK, 23dBm, Band 13, 26, 5, 18, 19, 20, 8
	430	750	3.75KHz subcarrier spacing, 1 SC, RU 32ms, TBS=0, BPSK, 23dBm, Band 3, 2, 25, 4, 1, 66
	68	300	15KHz subcarrier spacing, 12 SC, RU 1ms, TBS=5, QPSK, 21dBm, Band 71
	88	950	15KHz subcarrier spacing, 12 SC, RU 1ms, TBS=5, QPSK, 23dBm, Band 85, 28, 12
	78	800	15KHz subcarrier spacing, 12 SC, RU 1ms, TBS=5, QPSK, 23dBm, Band 13, 26, 5, 18, 19, 20, 8
	77	730	15KHz subcarrier spacing, 12 SC, RU 1ms, TBS=5, QPSK, 23dBm, Band 3, 2, 25, 4, 1, 66
GPRS	300	2000	1TX + 1RX, CS1, GMSK, Band 850, 900
	170	1000	1TX + 1RX, CS1, GMSK, Band 1800, 1900

Table 19: ME310G1-WW and ME310G1-WWV Connected Mode

4.2.4 ME310G1-W2 Connected Mode

Connected mode	Measure (Typical)		Mode Description
	Average (mA)	Peak (mA)	
CATM	180	400	1 RB, RMC, TBS=5, QPSK, 21dBm, B1, B3, B8, B20, B28
	300	680	1 RB, RMC, TBS=5, QPSK 26dBm, B31, B72
NBloT	245	340	3.75KHz subcarrier spacing, 1 SC, RU 32ms, TBS=0, BPSK, 21dBm, B1, B3, B8, B20, B28
	430	570	3.75KHz subcarrier spacing, 1 SC, RU 32ms, TBS=0, BPSK, 23dBm, B31, B72
	65	290	15KHz subcarrier spacing, 12 SC, RU 1ms, TBS=5, QPSK, 21dBm, B1, B3, B8, B20, B28
	70	430	15KHz subcarrier spacing, 12 SC, RU 1ms, TBS=5, QPSK, 23dBm, B31, B72

Table 20: ME310G1-W2 Connected Mode

4.2.5 ME310G1-W3 Connected Mode

Mode	Measure (Typical)		Mode Description
	Average (mA)	Peak (mA)	
Connected mode			
CATM	210	520	1 RB, RMC, TBS=5, QPSK, 23dBm, Band 26, 5
	230	460	1 RB, RMC, TBS=5, QPSK, 23dBm, Band 3

Table 21: ME310G1-W3 Connected Mode

4.3 General Design Rules

The Power Supply Design guidelines include three different design steps:

- Electrical design
- Thermal design
- PCB layout

4.3.1 Electrical Design Guidelines

The electrical design of the power supply depends on a drained power source.

The electrical design guidelines categories are:

- +5V input (typically PC internal regulator output)
- +12V input (typically automotive)
- Battery

4.3.1.1 +5V Source Power Supply Design Guidelines

The desired output for the power supply is 3.8V. Since the difference between the input source and the desired output is negligible, a linear regulator may be used. A switching power supply will not be suitable because of the low dropout requirements.

- If using a linear regulator, include a heat sink to dissipate excess generated power.
- A low ESR bypass capacitor must be included to stop the current absorption peaks near the module. The recommended capacitor is 100 μ F.
- Make sure that the low ESR capacitor on the power supply output is a minimum of 10V nominal.

An example of a linear regulator with 5V input is:

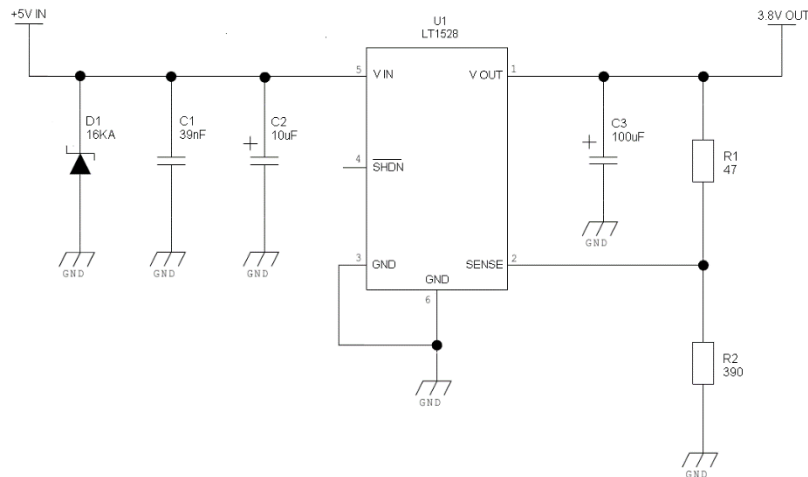

Figure 3: Example of a linear regulator with 5V input

4.3.1.2 +12V Source Power Supply Design Guidelines

The desired output for the power supply is 3.8V, so due to the large difference between the input source and the desired output, a linear regulator is not suitable and shall not be used. A switching power supply will be preferable because of its better efficiency.

- A regulator must be provided to absorb current peaks. The recommended switching regulator is 500kHz. Due to its smaller inductor size and faster transient response, it has a higher switching frequency.
- The frequency and selection of switching design are related to the application. Since the switching frequency could also generate EMC interference.
- For a PB car battery, the input voltage may rise up to 15.8V and this must be considered when selecting components. All components in the power supply must support this voltage.
- A low ESR bypass capacitor must be included to stop the current absorption peaks near the module. The recommended capacitor is 100 μ F.
- Make sure that the low ESR capacitor on the output of the power supply is rated at least 10V.
- For Car applications, a spike protection diode must be placed close to the power input, to clean the power supply spikes.

An example of a switching regulator with 12V input is in the below schematic:

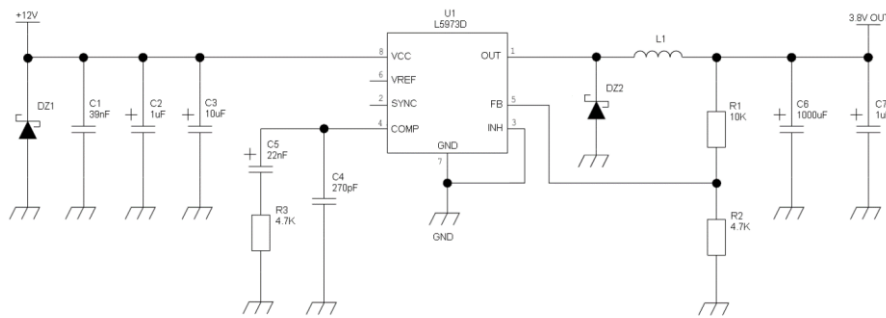

Figure 4: Switching regulator with 12V input

4.3.1.3 Battery Source Power Supply Design Guidelines

The nominal output of the desired power supply is 3.8V and the maximum voltage is 4.2V. So a single 3.7V Li-Ion battery type is sufficient to power the Telit ME310G1 module.

- A low ESR bypass capacitor must be included to stop the current absorption peaks near the module. The recommended capacitor is 100 μ F tantalum.
- Make sure the low ESR capacitor on the power supply output is rated at least 10V.
- A protection diode must be placed near the power input. This protects the ME310G1 from power polarity inversion. Otherwise, the battery connector must be specifically designed to avoid polarity inversions when connecting the battery.
- The battery must be rated to supply current peaks up to 2A.



Note: DO NOT USE any Ni-Cd, Ni-MH, or Pb batteries with the Telit ME310G1 module. Any type of battery other than Li-Ion may result in overvoltage issues and damage it. You can use LI-Ion, Li-Po, Li-FePO₄ secondary batteries or hi current Lithium primary batteries.

4.3.2 Thermal Design Guidelines

Worst case as reference values for thermal design of ME310G1 are:

- Average current consumption (LTE CAT M1 and NB1 modes): 700 mA
- Average current consumption (GPRS and EDGE modes): 700 mA
- Supply voltage: 4.50V



Note: The PCB design must be well connected to the GND pads, which is connected to a large copper surface.



Note: The Telit ME310G1 module includes a function to prevent overheating.

4.3.3 Power Supply PCB Layout Guidelines

As seen in the electrical design guidelines, the power supply must have a low ESR capacitor on the output to cut the current peaks on the input to protect the supply from spikes. The positioning of this component is essential for the correct functioning of the circuitry. A misplaced component can be useless or can even decrease the power supply performance.

- The low ESR Bypass capacitor must be placed near the Telit ME310G1 power input pads or, if the power supply is of the switching type, it can be placed near the inductor to cut the ripple, provided that the PCB trace from the capacitor to the ME310G1 is wide enough to ensure a dropless connection even during a 2A current peak.
- The protection diode must be placed close to the input connector where the power source is drained.
- The PCB's traces to the ME310G1 and the Bypass capacitor must be wide enough to ensure that no significant voltage drops occur. This is for the same reason as in the previous point. Try to keep this trace as short as possible.
- To reduce EMI due to switching, it is important to keep the mesh involved very small; then the input capacitor, the output diode (if not incorporated into the IC) and the regulator will form a very small loop. This is done to reduce the radiated field (noise) to the switching frequency (usually 100-500 kHz).
- A dedicated ground for the Switching regulator separated from the common ground plane is suggested.
- The placement of the power supply on the board must be done in such a way as to guarantee that the high current return paths in the ground plane do not overlap with noise-sensitive circuitry such as the microphone amplifier/buffer or the earphone amplifier.
- Power supply input cables should be kept separate from noise-sensitive lines such as microphone/earphone cables.

- The insertion of the EMI filter on the VBATT pins is recommended in those designs where the antenna is placed near batteries or power supply lines. For this purpose, a Murata BLM18EG101TN1 or Taiyo Yuden P/N FBMH1608HM101 ferrite bead can be used.

The below figure shows the recommended circuit:

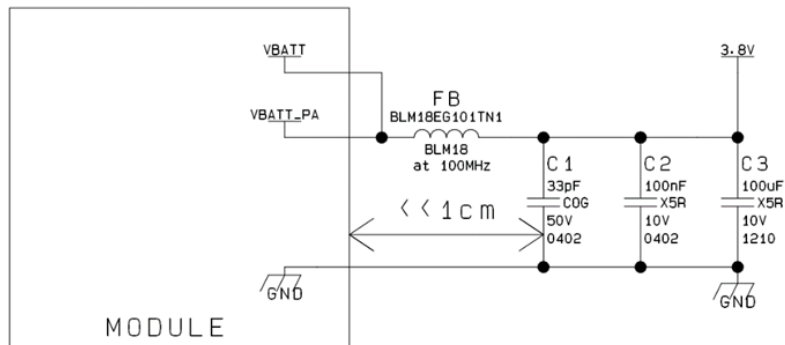

Figure 5: Recommended circuit

4.4 RTC Supply

RTC is functional when ME310G1 is in PSM or OFF state and VBATT pin is supplied.

RTC settings are lost when the VBATT supply is disconnected.

4.5 PWRMON Power-on Monitor

PWRMON is always active (output high) when the module is powered ON (module powered ON indication) and cannot be set to a LOW level with AT commands.

This signal is present on pin R1.

The following are the operating range characteristics of the PWRMON signal:

Item	Min	Typical	Max
Output voltage	1.35V	1.8V	1.8V
Output current	-	1mA	3mA

Table 22: Operating range characteristics of PWRMON signal



Note: The Output Current MUST never be exceeded. To avoid excessive current consumption, be sure to carefully design the application section.

If the current exceeds the limit, the module may shutdown.



Note: PWRMON during the PSM period is LOW.
(PSM must be previously enabled by AT+CPSMS command).



Warning: This signal is NOT provided to supply small devices from the module.

PWRMON is only a module power-on indicator.

5 DIGITAL SECTION

ME310G1 has four main operation states:

- **OFF state:** VBATT is applied and only RTC is running. The Baseband is switched OFF and the only possible change is the ON state.
- **ON state:** The baseband is fully switched on and the module is ready to accept AT commands. The module may be idle or connected.
- **Sleep mode state:** The main baseband processor is intermittently switched ON and AT commands may be processed with some latency. The module is idle with low current consumption.
- **Deep sleep mode state:** PSM is defined in 3GPP release 12. The baseband is switched OFF most of the time.

5.1 Logic Levels

Parameter	Min	Max
ABSOLUTE MAXIMUM RATINGS – NOT FUNCTIONAL		
Input level on any digital pin (CMOS 1.8) with respect to ground	-0.3V	2.1V
Operating Range - Interface levels (1.8V CMOS)		
Input high level	1.5V	1.9V
Input low level	0V	0.35V
Output high level	1.6V	1.9V
Output low level	0V	0.2V

Table 23: Logic levels Minimum and maximum

Parameter	Max
Current characteristics:	
Output Current	1mA
Input Current	1uA

Table 24: Logic levels average

5.2 Power On

The following flow chart shows the proper “Modem Turn ON” procedure.

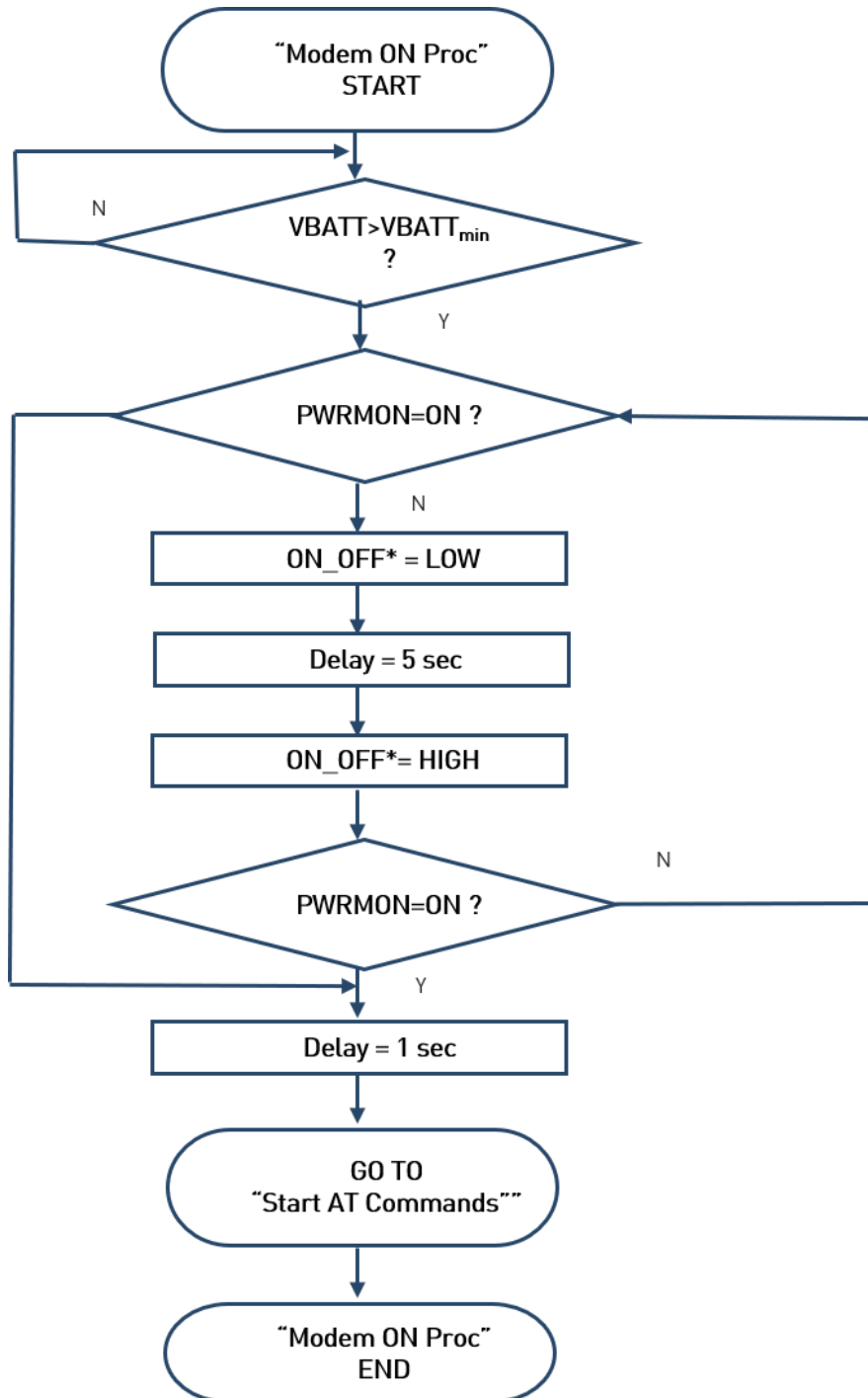

Figure 6: Modem On Process flow chart

In some use cases ON_OFF* can be tied fix LOW considering two limitations:

1. PSM wake-up asynchronous capability will be lost.
2. To perform an unconditional shutdown, it is necessary to send AT#SYSHALT command and then stop VBATT.

5.3 Power Off

The proper procedure to power off the module is to use the AT#SHDN command.

An alternative procedure is to use the ON_OFF* pin as described in the following procedure:

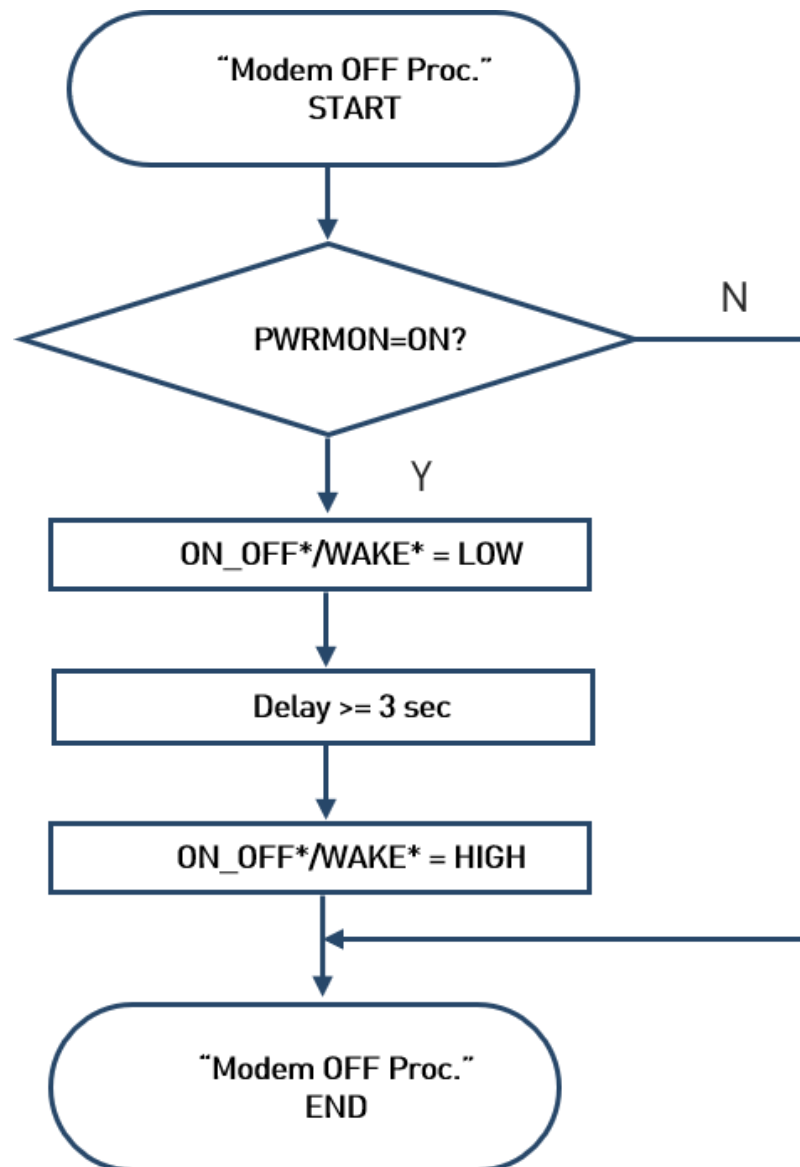

Figure 7: Modem OFF Process flow chart

5.4 Unconditional Shutdown

The following flow chart shows the proper procedure for an unconditional shutdown of the Telit ME310G1 module, except in PSM mode. When the procedure is completed the module is reset and stops all operations. After the release of the line, the module is unconditionally shut down, without performing any disconnection from the network in which it is registered.

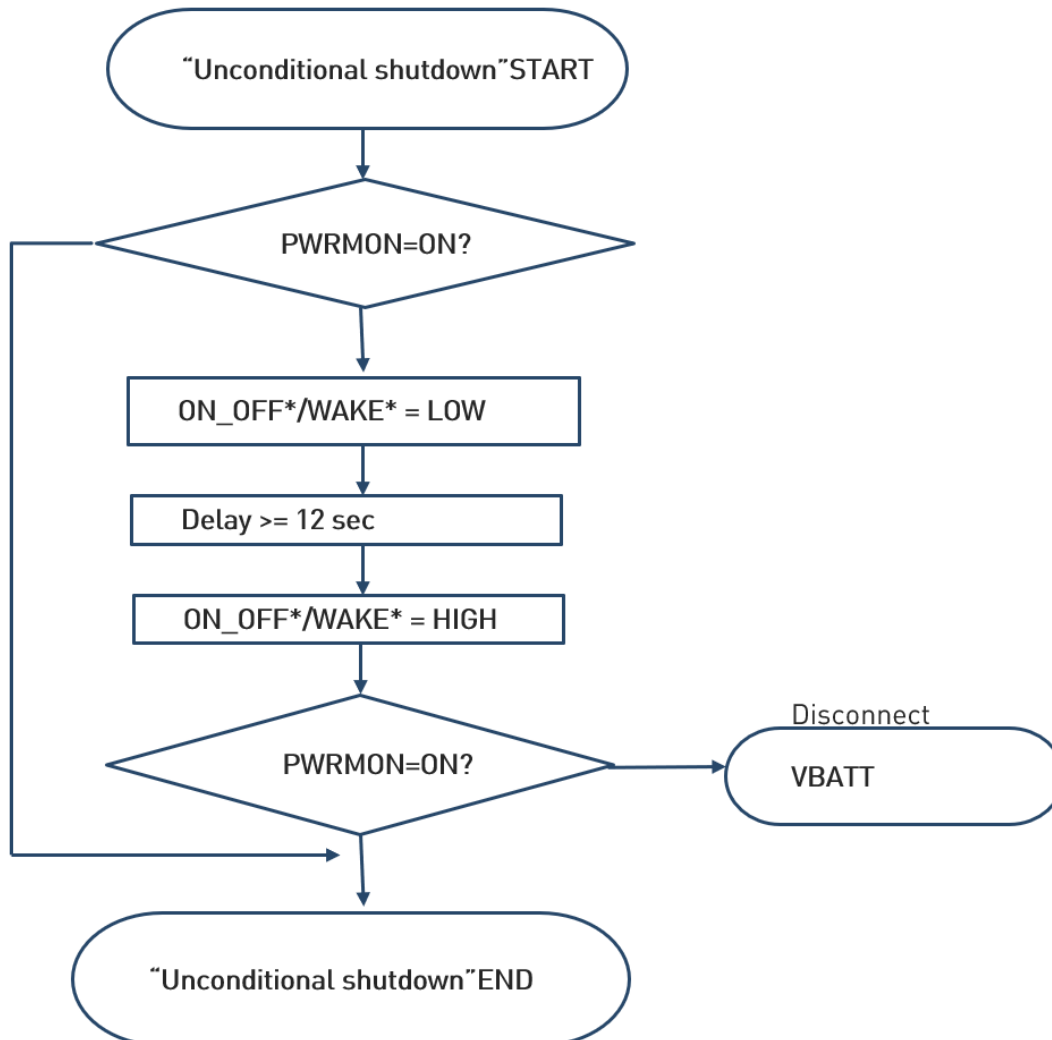

Figure 8: Unconditional shutdown of ME310G1



Warning: The Unconditional Hardware SHUTDOWN through the activation of VBATT Power, must not be used during the normal shutdown operation of the device. It does not disconnect the device from the network and may damage the memory contents. It must be performed only as an emergency exit procedure.

INCORRECT SHUTDOWN Procedure may void the warranty.

5.5 Wake up From Deep Sleep Mode

The ME310G1 module supports Power Saving Mode (PSM) functionality defined in 3GPP release 12. When the Periodic Update Timer expires, the module shuts down until the next scheduled wake-up. Host-controlled asynchronous events can wake up the module from deep sleep mode by asserting the ON_OFF*/WAKE* pin LOW for at least 5 seconds. The host can detect deep sleep mode by pulling the PWRMON pin if PSM has been previously configured.

5.6 Fast Shut Down

The procedure to power off the Telit ME310G1 module is explained in the [Power Off](#) section. It normally takes more than a second to disconnect from the network and properly close the internal filesystem. Fast Shut Down feature enables proper system shutdown without any filesystem corruption. You can use this feature during an unexpected supply voltage loss. Fast Shut Down feature enables you to reduce current consumption and minimize the time-to-power off values.



Note: For more information Refer to ME310G1/ME910G1/ML865G1 AT Commands Reference Guide (Fast shut down - #FASTSHDN) to set up a detailed AT command.

5.6.1 Fast Shut Down by Hardware

The Fast Shut Down by hardware may be triggered by configuring a GPIO. HI level to the LOW level transition of a GPIO triggers the Fast Shut Down by hardware procedure.

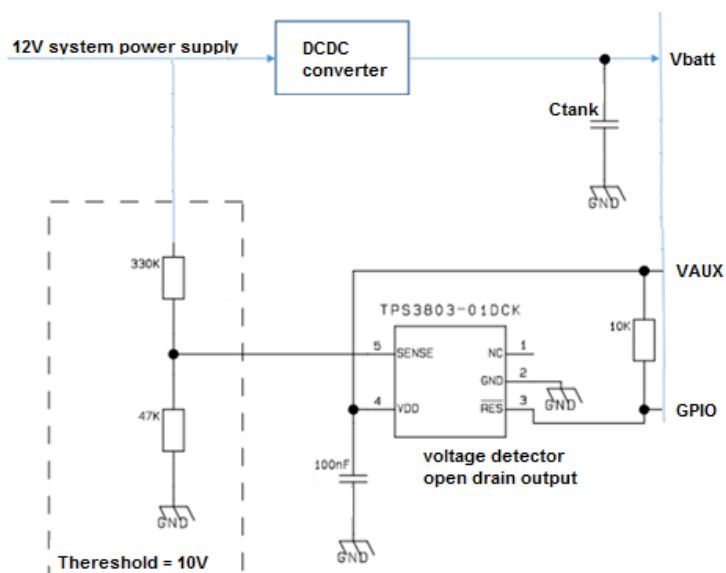

Figure 9: Example circuit



Note: Consider the voltage drop under max current conditions when defining the voltage detector threshold to avoid unwanted shutdown.

5.6.2 Fast Shut Down by Software

The Fast Shut Down can be triggered by AT command.

5.7 Communication Ports

5.7.1 USB 2.0 HS

The Telit ME310G1 module includes an integrated universal serial bus (USB 2.0 HS) transceiver. The following table lists the available signals:

PAD	Signal	I/O	Function	NOTE
U19	USB_D+	I/O	USB differential Data (+)	
V18	USB_D-	I/O	USB differential Data (-)	
T18	VUSB	AI	Power sense for the internal USB transceiver.	

Table 25: USB 2.0HS available signals

The following are the USB_VBUS input voltage range and input current:

Parameter	Min	Max
ABSOLUTE MAXIMUM RATINGS – NOT FUNCTIONAL		
USB_VBUS Input level	-0.3V	6.0V
Operating Range		
USB_VBUS Input high level	1.0V	5.25V
USB_VBUS Input low level	0V	0.4V

Table 26: Voltage range

Parameter	TYP
Current characteristics:	
USB_VBUS Input Current	6 μ A

Table 27: Input current

5.7.2 SPI

The Telit ME310G1 module is provided by a standard 3-wire SPI master or slave interface with chip select control.

The following are the available signals:

PAD	Signal	I/O	Function	Type	NOTE
AA5	SPI_MOSI	I/O	SPI MOSI	CMOS 1.8V	
Y8	SPI_MISO	I/O	SPI MISO	CMOS 1.8V	
AA7	SPI_CLK	I/O	SPI Clock	CMOS 1.8V	
Y6	SPI_CS	I/O	SPI Chip Select	CMOS 1.8V	

Table 28: Available signals



Note: The SPI interface is supported by the Telit AppZone API's.

5.7.3 Serial Ports

The Telit ME310G1 module includes 3 Asynchronous serial ports:

- Asynchronous Serial Port (USIF0)
- Asynchronous Serial Port (USIF1)*
- Auxiliary Serial Port

You may design various serial port configurations on the OEM hardware.

The common designs are:

- RS232 PC com port
- Microcontroller UART @ 1.8V (Universal Asynchronous Receive Transmit)
- Microcontroller UART @ 5V or other voltages different from 1.8V

Depending on the serial port type on the OEM hardware, a level translator circuit may be required to operate the system. The serial port on the module is CMOS 1.8.



Note: *The USIF1 is currently NOT supported by ME310G1 firmware.

5.7.3.1. Asynchronous Serial Port (USIF0)

The serial port 0 on the Telit ME310G1 module is a +1.8V UART with 5 RS232 signals.

It differs from the PC-RS232 in signal polarity (RS232 is reversed) and levels.

The following are the available signals:

RS232 Pin	Signal	Pad	Name	Usage
2	C104/RXD0	AA15	Transmit line	Output transmit line of ME310G1 UART
3	C103/TXD0	Y16	Receive line	Input receive of the ME310G1 UART Pull-up default during ON state
4	DTR	(*)	Data Terminal Ready	Input to the ME310G1 that controls the DTE READY condition
5	GND	A3, A7, A9, A13, A17, B4, B6, B10, B12, B14, B16, C19, D18, F8, F12, F18, G19, H6, H14, J19, K18, M18, N19, P6, P14, T8, T12, U1, V2, W19, Y2, Y4	Ground	Ground
8	C106/CTS0	AA17	Clear to Send	Output from the ME310G1 that controls the Hardware flow control
7	C105/RTS0	Y18	Request to Send	Input to the ME310G1 that controls the Hardware flow control Pull-up default during ON state
9	RING	(*)	Ring Indicator	Output from the ME310G1 that indicates the incoming call condition

Table 29: Available signs

* For alternate GPIO functions, refer to General Purpose I/O

Note: According to V.24, some signal names refer to the application side, so on the ME310G1 side these signals are in the opposite direction:

TXD on the application side is connected to the receiving line (here named C103/TXD0)

RXD on the application side is connected to the transmit line (here named C104/RXD0)

For reduced implementation, only the TXD, RXD lines can be connected, the other lines can be left open.

To avoid a back powering it is recommended to prevent any HIGH logic level signals from being applied to the digital pins of the ME310G1 when the module is powered off or during an ON/OFF transition.

5.7.3.1 Asynchronous Serial Port (USIF1)

The serial port 1 on the Telit ME310G1 module is a +1.8V UART with 5 RS232 signals. It differs from PC-RS232 in signal polarity (RS232 is reversed) and levels.



Warning: C104/RXD1 cannot have any PU or HIGH state during BOOTING UP phase.

The following are the available signals:

RS232 Pin	Signal	Pad	Name	Usage
2	C104/RXD1	AA11	Transmit line	Output transmit line of ME310G1 UART
3	C103/TXD1	Y12	Receive line	Input receive of the ME310G1 UART Pull-up default during ON state
5	GND	A3, A7, A9, A13, A17, B4, B6, B10, B12, B14, B16, C19, D18, F8, F12, F18, G19, H6, H14, J19, K18, M18, N19, P6, P14, T8, T12, U1, V2, W19, Y2, Y4	Ground	Ground
8	C106/CTS1	Y14	Clear to Send	Output from the ME310G1 that controls the Hardware flow control
7	C105/RTS1	AA13	Request to Send	Input to the ME310G1 that controls the Hardware flow control Pull-up default during ON state

Table 30: ME310G1 port signals

5.7.3.2 Auxiliary Serial Port

The auxiliary serial port on the Telit ME310G1 module is a CMOS 1.8V with only the RX and TX signals.

The following are the available serial port:

PAD	Signal	I/O	Function	Type	NOTE
Y10	TX_AUX	O	Auxiliary UART (TX Data to DTE)	CMOS 1.8V	
AA9	RX_AUX	I	Auxiliary UART (RX Data from DTE)	CMOS 1.8V	

Table 31: ME310G1 serial port signals

5.8 General Purpose I/O

The Telit ME310G1 module includes a set of configurable digital input and output pins (CMOS 1.8V). The Input pads can only be read. They report the digital value (high or low) present on the pad at the time of reading. The Output pads can only be written or queried and set the value of the pad output.

An alternate function pad is controlled internally by the module firmware and depends on the function implemented.

The following are the available GPIO:

PAD	Signal	I/O	Drive Strength	Default State	NOTE
V11	GPIO_01	I/O	1 mA	INPUT - PD (100K)	Alternate function DTR INPUT - PU (100K)
V13	GPIO_02	I/O	1 mA	INPUT - PD (100K)	Alternate function RING
D7	GPIO_03	I/O	1 mA	INPUT - PD (100K)	
D9	GPIO_04	I/O	1 mA	INPUT - PD (100K)	
D11	GPIO_05	I/O	1 mA	INPUT - PD (100K)	
D13	GPIO_06	I/O	1 mA	INPUT - PD (100K)	

Table 32: ME310G1 available GPIO

5.8.1 Using a GPIO as INPUT

GPIO pads, when used as inputs, can be connected to the digital output of another device to report its status. Make sure the external device is compatible at interface levels with the 1.8V CMOS levels of the GPIO.



Note: To avoid back power, it is recommended to avoid applying any HIGH logic level signal to the digital pins of the ME310G1 when the module is powered off or during an ON/OFF transition.

5.8.2 Using a GPIO as OUTPUT

GPIO pads, when used as outputs, may drive the 1.8V CMOS digital devices or compatible hardware. When set as outputs, the pads have a push-pull output and therefore the pull-up resistor may be omitted.

5.9 External SIM Holder

Refer to the SIM Holder Design Guide, 80000NT10001A.

Note: There is no dedicated signal (SIMIN) for “Presence SIM” in the Telit ME310G1 module pinout.

This feature may be performed by connecting the GPIO_01 (Pad V11) or GPIO_02 (Pad V13) or GPIO_03 (Pad D7) or GPIO_04 (Pad D9) to the switch embedded into the sim-holder.

SIM detection may be configured by a specific AT Command.

Refer to the SW User Guide or AT Commands Reference Guide for a complete description of this function.

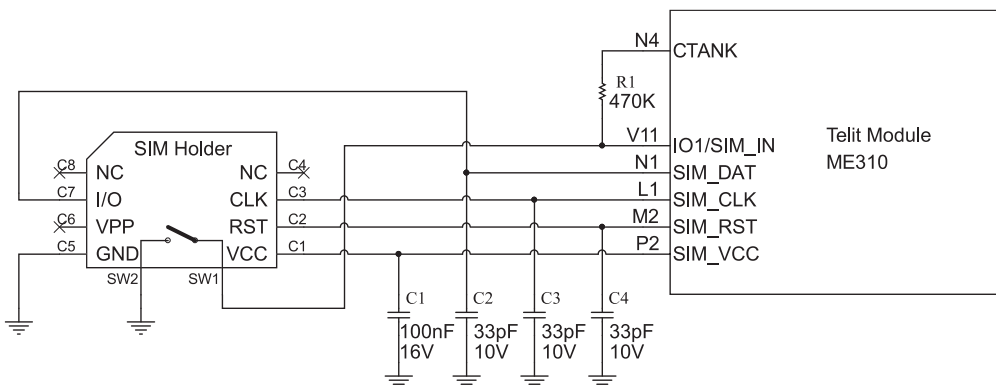

Figure 10: SIM Holder schematic



Warning: Pull-up 470K is required across CTANK (ball N4) and switch embedded in the sim-holder

5.10 ADC Converter

The Telit ME310G1 module includes an AD converter. It can read a voltage level in the range of 0÷1.8V applied on the ADC pin input, store it and convert it to 10-bit words.

The input lines are called **ADC** (available on Pad **B18**).

Item	Min	Typical	Max	Unit
Input Voltage range	0	-	1.8	Volt
AD conversion	-	-	10	bits

Table 33 ADC Characteristics

5.10.1 Using ADC Converter

Available in the next document revision.

5.11 DAC Converter

The Telit ME310G1 module includes a Digital Analog Converter. The signal (named DAC) is available on pin **R16** of the module.

5.11.1 Enabling DAC

Available in a next document revision.

5.12 CTANK

The Telit ME310G1 module includes an internal supply domain pin for additional capacitance or pull up reference. It supports only the specific use cases described in the Telit ME310G1 module documentation. The internal supply domain (named CTANK) is available on pin N4 of the ME310G1.

The user's application circuit should add a place-holder capacitor of 100uF 4V connected to pin N4 of the ME310G1 to support an enhanced power loss recovery.

5.13 Forced USB Boot

In some cases of firmware upgrade, the FORCED_USB_BOOT pin must be set to 1.8V when power-on of the module.

The input current is very low, so 10K resistor to CTANK (pin N4) may be used to keep this pin in the HI state.

FORCED_USB_BOOT pin must be connected only during the firmware upgrade operation. It must be left open during normal operation.

FORCED_USB_BOOT and CTANK pins must be available in the user application circuit at all test points for easy connection of the 10K resistor.

5.14 Antenna Tuner

The Telit ME310G1 module includes a feature to enable an external antenna tuning solution. This enables to dynamically tune the antenna on multiple frequencies.

Refer to AT command AT#ATUNERSEL (AT Commands Reference Guide-Telit code 80617ST10991A) to select GPIO or MIPI interfaces on ATC1/ATC2 pins.

5.14.1 GPIO

ATC1 Pin	ATC2 Pin	Band (Uplink)	Freq. Range [MHz]
0	0	B1, B2, B3, B4, B25, B66, GSM1800, GSM1900	1710-2200
0	1	B8, EGSM900	880-960
1	0	B5, B18, B19, B20, B26, B27 GSM850	791-894
1	1	B12, B13, B28, B85	698-803

Table 34 Antenna Tuner GPIO table

5.14.2 MIPI

The MIPI interface is intended to be used in bundle with Qualcomm QAT3516 Adaptive Aperture Tuner.

See Antenna Aperture Tuning MIPI Application Note (Telit code 80660NT11911A) for further details.

6 RF SECTION

6.1 Antenna Requirements

The antenna connection and the board layout design are the most important aspect of the complete product design. It strongly affects the performance of the product. Be sure to follow the requirements and guidelines for a proper design.

The following are the antenna and antenna transmission line requirements:

Item	Value
Frequency range	Depending by frequency band(s) provided by the network operator, the customer shall use the most suitable antenna for that/those band(s)
Bandwidth	250 MHz in LTE Band 1 140 MHz in LTE Band 2, PCS1900 170 MHz in LTE Band 3, DCS1800 445 MHz in LTE Band 4 70 MHz in LTE Band 5, GSM850 80 MHz in LTE Band 8, GSM900 47 MHz in LTE Band 12 41 MHz in LTE Band 13 60 MHz in LTE Band 18 60 MHz in LTE Band 19 71 MHz in LTE Band 20 145 MHz in LTE Band 25 80 MHz in LTE Band 26 62 MHz in LTE Band 27 100 MHz in LTE Band 28 15 MHz in LTE Band 31 490 MHz in LTE Band 66 81 MHz in LTE Band 71 15 MHz in LTE Band 72 48 MHz in LTE Band 85
Impedance	50 ohm
Input power	ME310G1-W1: > 24dBm Average power ME310G1-WW: > 33dBm Average power ME310G1-W2: > 26dBm Average power
VSWR absolute max	≤ 10:1 (limit to avoid permanent damage)
VSWR recommended	≤ 2:1 (limit to fulfill all regulatory requirements)

Table 35: ME310G1 Antenna and Antenna transmission line on PCB

6.1.1 PCB Design Guidelines

As there is no antenna connector on the ME310G1 module, you must use a transmission line to connect the antenna to the antenna pad on the PCB.

The following are the transmission line requirements:

Item	Value
Characteristic Impedance	50 ohm (+-10%)
Max Attenuation	0.3 dB
Coupling	Coupling with other signals shall be avoided
Ground Plane	The Cold End (Ground Plane) of the antenna shall be equipotential to the ME310G1 ground pins

Table 36: ME310G1 Antenna pad requirements

The transmission line should be designed according to the following guidelines:

- Make sure that the characteristic impedance of the transmission line is 50 ohm.
- Keep the line on the PCB as short as possible, as the loss of the antenna line should be less than about 0.3 dB.
- The Line geometry should have uniform characteristics, constant cross-section, avoid meanders and sharp curves.
- Any type of suitable geometry/structure (Microstrip, Stripline, Coplanar, Grounded Coplanar Waveguide...) can be used to implement the printed transmission line afferent to the antenna.
- If a Ground plane is required in line geometry, that plane shall be continuous and sufficiently extended so that the geometry can be as similar as possible to the related canonical model.
- Keep, if possible, at least one layer of the PCB used only for the Ground plane; If possible, use this layer as a reference Ground plane for the transmission line.
- It is advisable to surround (on both sides) the transmission line of the PCB with Ground, avoiding that other signal tracks face directly the antenna line track.
- Avoid crossing any un-shielded transmission line footprint with other signal tracks on different layers.
- The ground surrounding the antenna line on PCB shall be strictly connected to the main Ground Plane using via holes (at least once per 2mm), positioned near the ground edges facing the line track.

- Place the noisy EM devices as far as possible away from the ME310G1 antenna line.
- Keep the antenna line far away from the ME310G1 power supply lines.
- If there are noisy EM devices (such as fast switching ICs, LCD, and so on) on the PCB hosting the ME310G1, shield the antenna line by burying it in an inner layer of the PCB and surrounding it with the Ground planes, or shield it with a metal frame cover.
- If noisy EM devices are not present around the line, it is preferable to use geometries such as Microstrip or Grounded Coplanar Waveguide as they typically ensure less attenuation than a Stripline of the same length.

The following image is showing the suggested layout for the Antenna pad connection:

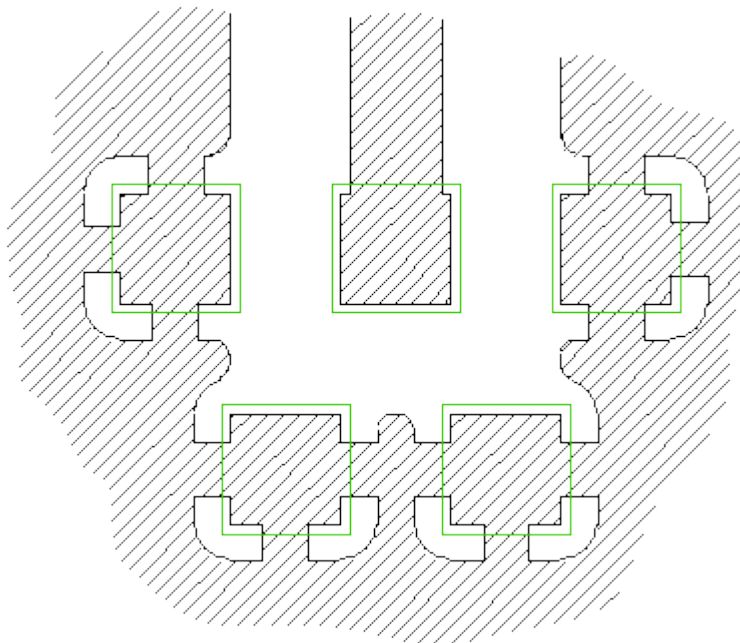

Figure 11: Layout for the Antenna pad connection

6.1.2 PCB Guidelines in Case of FCC Certification

In case FCC certification is required for an application using ME310G1, according to FCC KDB 996369 for modular approval requirements, the transmission line must be similar to the one implemented on the ME310G1 interface board and described in the following chapter.

6.1.2.1 Transmission Line Design

When designing the ME310G1 interface board, the placement of components was chosen properly, in order to keep the line length as short as possible, thus leading to the lowest possible power losses. A Grounded Coplanar Waveguide (G-CPW) line was chosen, since this kind of transmission line ensures good impedance control and can be implemented in an outer PCB layer as needed in this case. A SMA female connector has been used to feed the line.

The interface board is made on a FR4, 4-layers PCB. The substrate material is characterized by relative permittivity $\epsilon_r = 4.6 \pm 0.4 @ 1 \text{ GHz}$, $\text{TanD} = 0.019 \div 0.026 @ 1 \text{ GHz}$.

A characteristic impedance of nearly 50Ω is obtained using the trace width = 1.1 mm, clearance from a coplanar ground plane = 0.3 mm each side. The line uses the reference ground plane on layer 3, while copper is removed from layer 2 below the line. The height of the trace from the ground floor is 1.335 mm. The calculated characteristic impedance is 51.6Ω , the estimated line loss is less than 0.1 dB.

The line geometry is shown below:

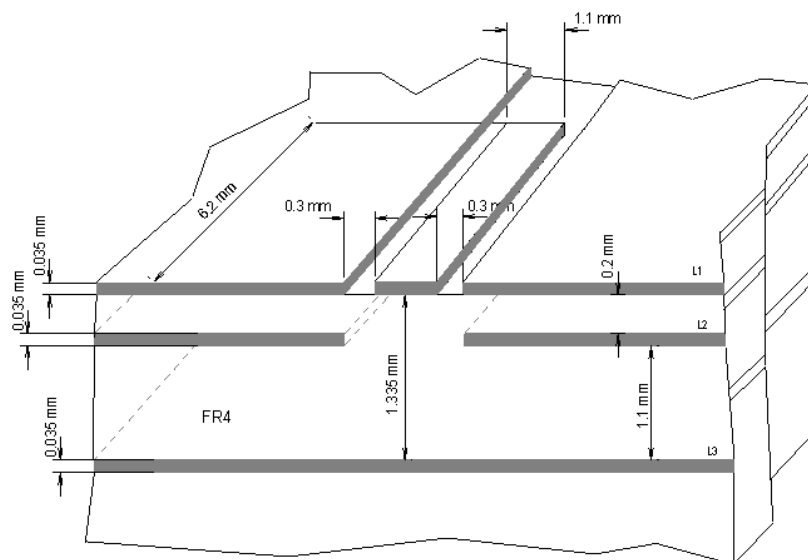

Figure 12: Line geometry

6.1.2.2 Transmission Line Measurements

An HP8753E VNA (Full-2-port calibration) was used in this measurement session.

A calibrated coaxial cable was soldered to the pad corresponding to RF output; a SMA connector was soldered to the board in order to characterize the losses of the

transmission line including the connector itself. During Return Loss / impedance measurements, the transmission line has been terminated to 50 Ω load.

Return Loss plot of line under test is shown below:

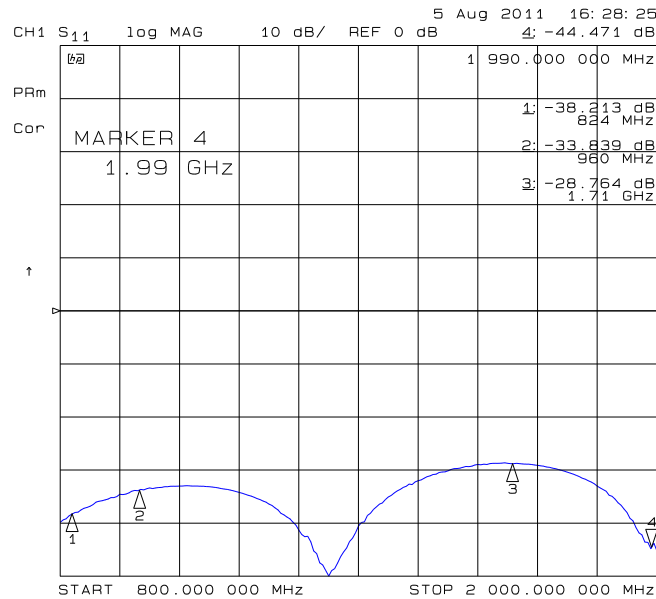

Figure 13: Return Loss plot of line under test

Line input impedance (in Smith Chart format, once the line has been terminated to 50 Ω load) is shown in the following figure:

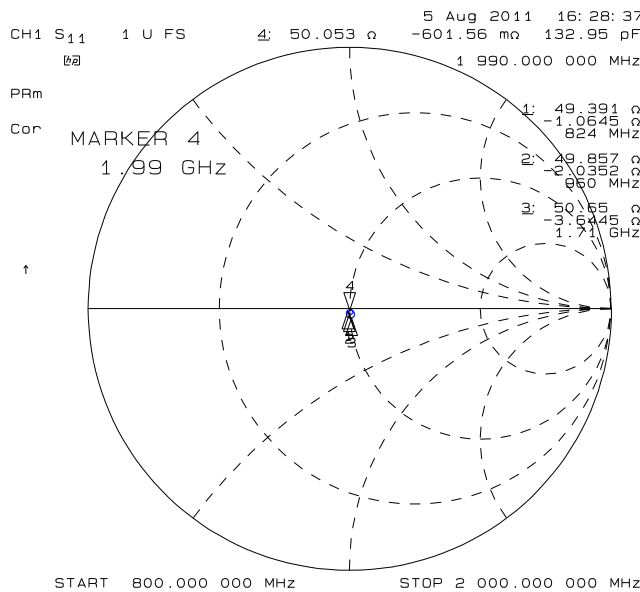

Figure 14: Line input impedance

Insertion Loss of G-CPW line plus SMA connector is shown below:

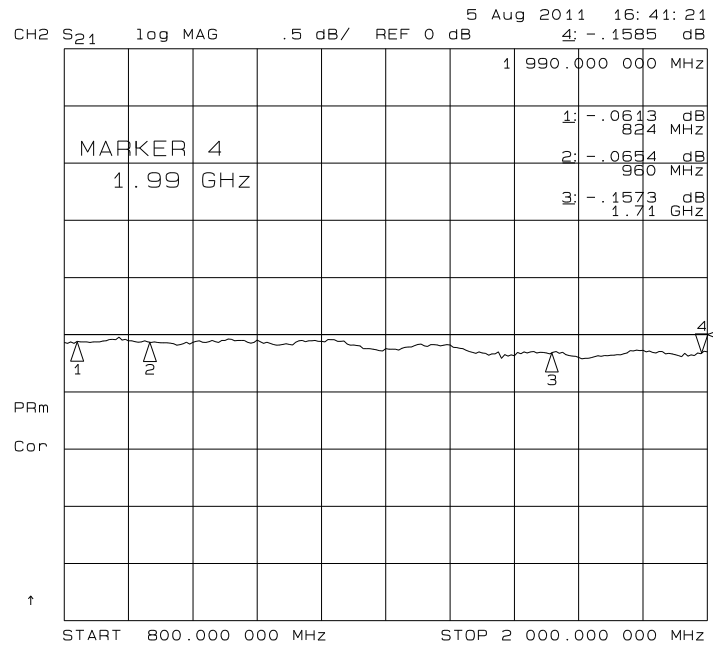

Figure 15: Insertion Loss of G-CPW line plus SMA connector

6.1.2.3 Antenna Installation Guidelines

- Install the antenna in a place covered by the LTE signal with CAT-M1 support.
- The Antenna must not be installed inside metal cases.
- The Antenna must be installed according Antenna manufacturer instructions.
- The Antenna integration should optimize the Radiation Efficiency. Efficiency values > 50% are recommended on all frequency bands.
- The Antenna integration should not perturb the radiation pattern described in the documentation of the Antenna manufacturer.
- It is preferable to obtain an omnidirectional radiation pattern.
- The Antenna Gain must not exceed the values indicated in regulatory requirements, where applicable, in order to meet related EIRP limitations. Typical antenna Gain in most M2M applications does not exceed 2dBi.
- If the device antenna is located farther than 20cm from the human body and there are no co-located transmitter, the Telit FCC/IC approvals can be re-used by the end product.



- If the device antenna is located closer than 20cm from the human body or there are co-located transmitter , the additional FCC/IC testing may be required for the end product (Telit FCC/IC approvals cannot be reused).

7 AUDIO SECTION

The Telit ME310G1 Module's digital voice interface is based on the I2S serial bus interface. The audio port can be connected to the digital interface which uses multiple compliant codecs (in case analog audio is needed). The audio port is available only in ME310G1-WWV that has CS Voice/VoLTE support.

7.1 Electrical Characteristics

The Telit ME310G1 module provides digital voice interface on the following PINs:

Pin	Signal	I/O	Function	Internal Pull Up	Type
C1	DVI_WA0	I/O	Digital Audio Interface (Word Alignment / LRCLK)		CMOS 1.8V
D2	DVI_RX	I	Digital Audio Interface (RX)		CMOS 1.8V
E1	DVI_TX	O	Digital Audio Interface (TX)		CMOS 1.8V
F2	DVI_CLK	I/O	Digital Audio Interface (BCLK)		CMOS 1.8V

Table 37: Electrical Characteristics

8 GNSS SECTION

The ME310G1 module includes a state-of-the-art receiver capable of simultaneously searching and tracking satellite signals from multiple satellite constellations. This multi-GNSS receiver uses the entire spectrum of available GNSS systems, such as GPS, GLONASS, BeiDou, Galileo, and QZSS.

8.1 GNSS Signals Pin-out

Pin	Signal	I/O	Function	Type
E19	ANT_GNSS	I	GNSS Antenna (50 ohm)	
H18	GNSS_LNA_EN	O	GNSS External LNA Enable	CMOS 1.8V
G16	GNSS_1PPS	O	1 Pulse per Second	CMOS 1.8V

Table 38: GNSS Signals Pin-out



Warning: GNSS_1PPS is not currently supported by software and it will be implemented in future SW releases.

8.2 RF Front End Design

The ME310G1 module does not contain the LNA required to achieve maximum sensitivity. The active antenna (antenna with a built-in low noise amplifier) must be supplied with a proper bias-tee circuit.

8.2.1 PCB Guidelines for GNSS Antenna

- Make sure the antenna line impedance is 50ohm.
- The antenna line on the PCB should be as short as possible to reduce the loss.
- The antenna line must have uniform characteristics, constant cross-section without meanders, or sharp curves.
- If possible, keep one layer of the PCB used only for the Ground plane.
- Wind (on both sides, above and below) the antenna line on the PCB with the Ground plane, make sure the other signal tracks are not directly facing the antenna line.
- The ground around the antenna line on the PCB must be firmly connected to the Ground plane by placing vias at a minimal of each 2mm.
- Place EM noisy devices as far as possible away from the antenna line.

- Keep the antenna line away from GSM RF lines and power supply lines.
- If there are noisy EM devices around the PCB hosting the module, such as fast switching ICs, take care of the antenna line shielding by burying it inside the PCB layers and surrounding it with Ground planes, or shielding it with a metal frame cover.
- For an EM noise environment, make sure to shield the antenna line with a metal frame cover or PCB layers and wind it with the Ground plane.
- For an EM noise free environment, shield the antenna line with a strip-line on the superficial copper layer. The line attenuation will be lower than the buried one.

8.2.2 Hardware-based Solution for GNSS and LTE Coexistence

If the decoupling between the LTE and GNSS antennas is low in a stand-alone GNSS receiver, the LTE transmission may desensitize the GNSS receiver. To protect the GNSS receiver from LTE out-of-band emissions, include a SAW filter on the LTE side as described in the diagram below.

There is no condition to degrade the GNSS receiver embedded in the ME310G1 module while it is in use. So filtering on the LTE is not mandatory as the LTE and GNSS cannot be active at the same time.

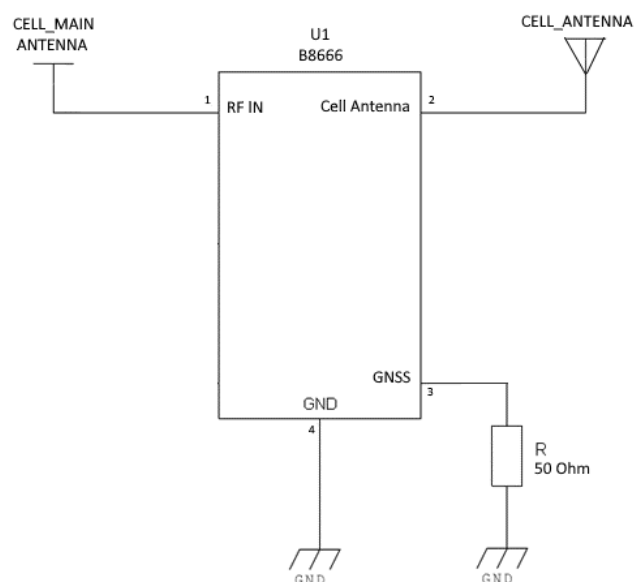

Figure 16: SAW filter on LTE side

8.3 GNSS Antenna Requirements

GNSS active antenna must be integrated into the application.

8.3.1 GNSS Antenna Specification

Item	Value
Frequency range	1559.0 ~ 1610.0 MHz
Gain	15 ~ 30dB
Impedance	50 ohm
Noise Figure of LNA	< 1.5 (recommended)
DC supply voltage	DC 1.8 ~ 3.3V
VSWR	≤ 3:1 (recommended)

Table 39: GNSS Antenna specification



Note: For a short antenna cable the minimal gain must be 15dB.
For a long antenna cable the minimal gain must be 30dB.

8.3.2 GNSS Antenna – Installation Guidelines

- For best performance of the GNSS receiver, the antenna must be installed according to the antenna manufacturer's instructions.
- The performance may degrade if the antenna is installed inside metal cases or near obstacles such as antenna lobes and gain.
- Evaluate the antenna location if it is connected to other antennas or transmitters.

8.3.3 Powering the External LNA (Active Antenna)

The active antenna requires either 1.8V or 3V DC power supply. To meet this requirement, an external power source with the ME310G1 module must be included in the user's application circuit.

The electrical characteristics of the GPS_LNA_EN signal are:

Level	Min	Max
Output High Level	1.6V	1.9V
Output Low Level	0V	0.3V

Table 40: GPS_LNA_EN signal characteristics

Example of external antenna bias circuitry:

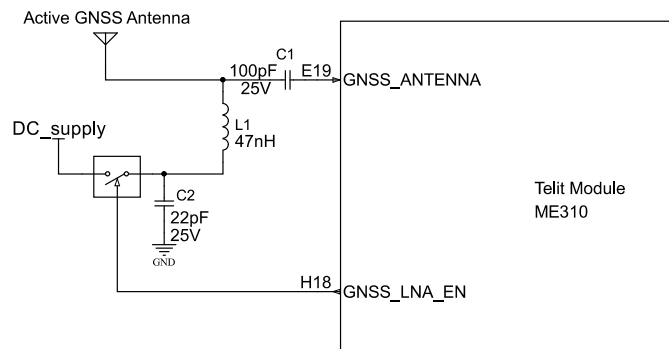

Figure 17: Antenna bias circuitry example



Warning: Ensure to regulate the maximum bias current. A short circuit on the antenna cable may damage the decoupling inductor.

8.4 GNSS Characteristics

The following table specifies the GNSS characteristics and the expected performance.

Parameters		Typical Measurement	Notes
Sensitivity	Tracking Sensitivity	-159 dBm	
	Navigation	-155 dBm	
	Cold Start	-144 dBm	
TTFF	Hot	N/A	It will be available in next revision
	Warm	<30s	GNSS Simulator test @-130dBm
	Cold	<30s	GNSS Simulator test @-130dBm
Min Navigation update rate		1Hz	
CEP		<2m	

Table 41: GNSS Characteristics

9 MECHANICAL DESIGN

9.1 Drawing

9.1.1 ME310G1-W1

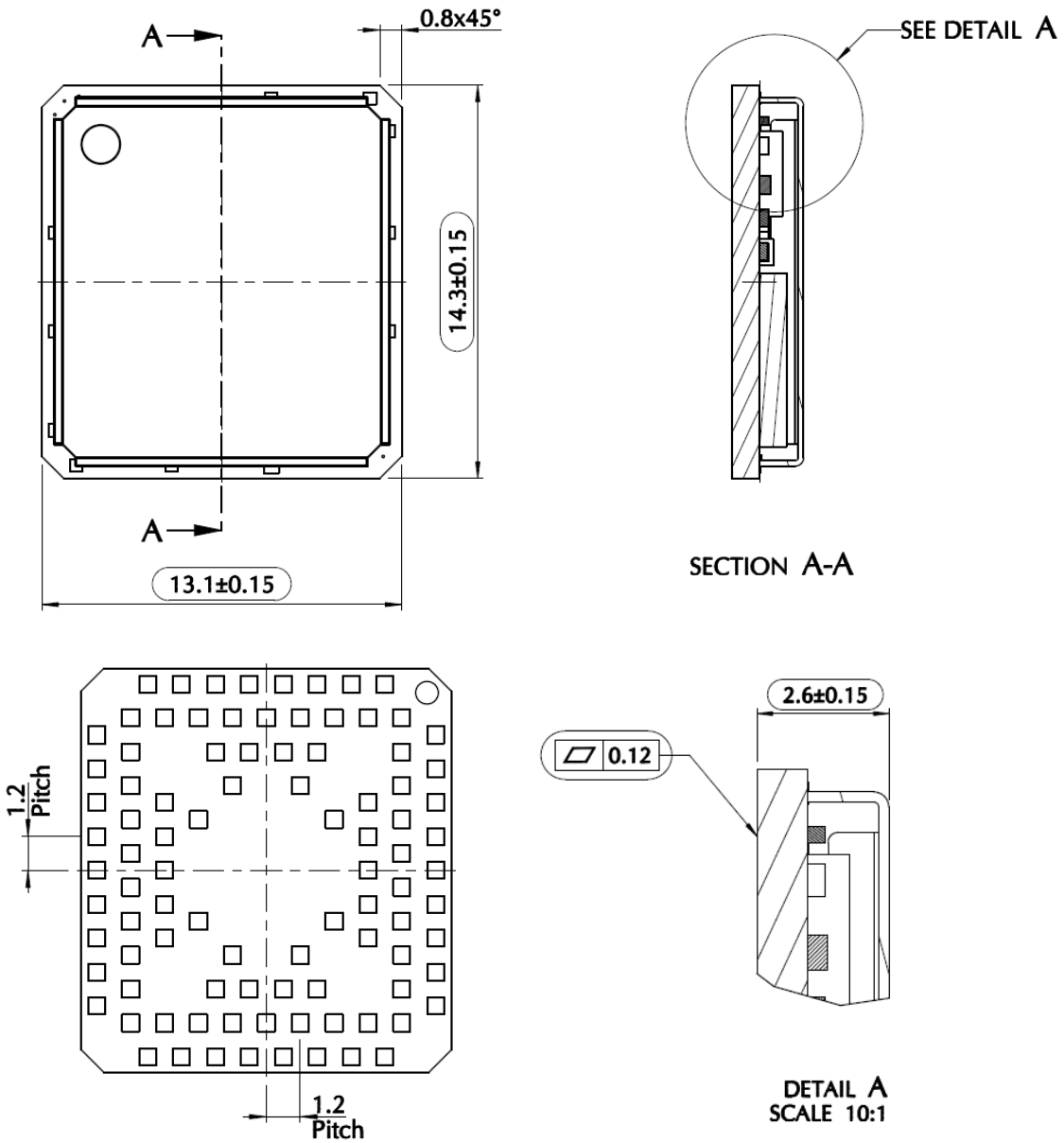

Figure 18: Mechanical Drawing of ME310G1-W1



Note: Dimensions are in mm. General Tolerance ± 0.1 , Angular Tolerance $\pm 1^\circ$, The tolerance is not cumulative.

9.1.2 ME310G1-WW, ME310G1-WWV, ME310G1-W2, and ME310G1-W3

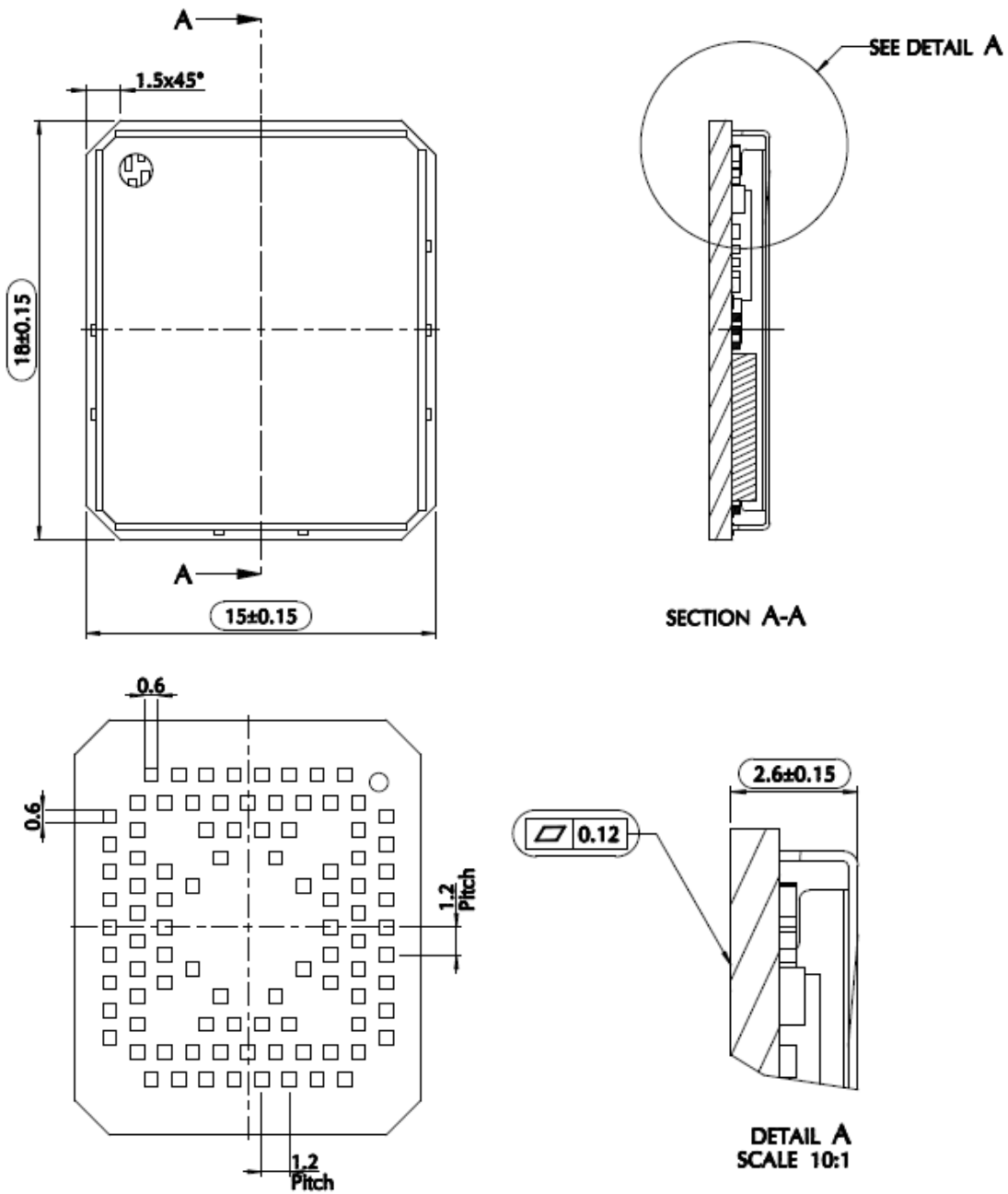

Figure 19: Mechanical Drawing of ME310G1-WW, ME310G1-WWV, ME310G1-W2, and ME310G1-W3

ME310G1 modules are compliant with a standard lead-free SMT process.

10 APPLICATION PCB DESIGN

ME310G1 modules have been designed to be compliant with a standard lead-free SMT process.

10.1 Footprint

10.1.1 ME310G1-W1

COPPER PATTERN (top view)

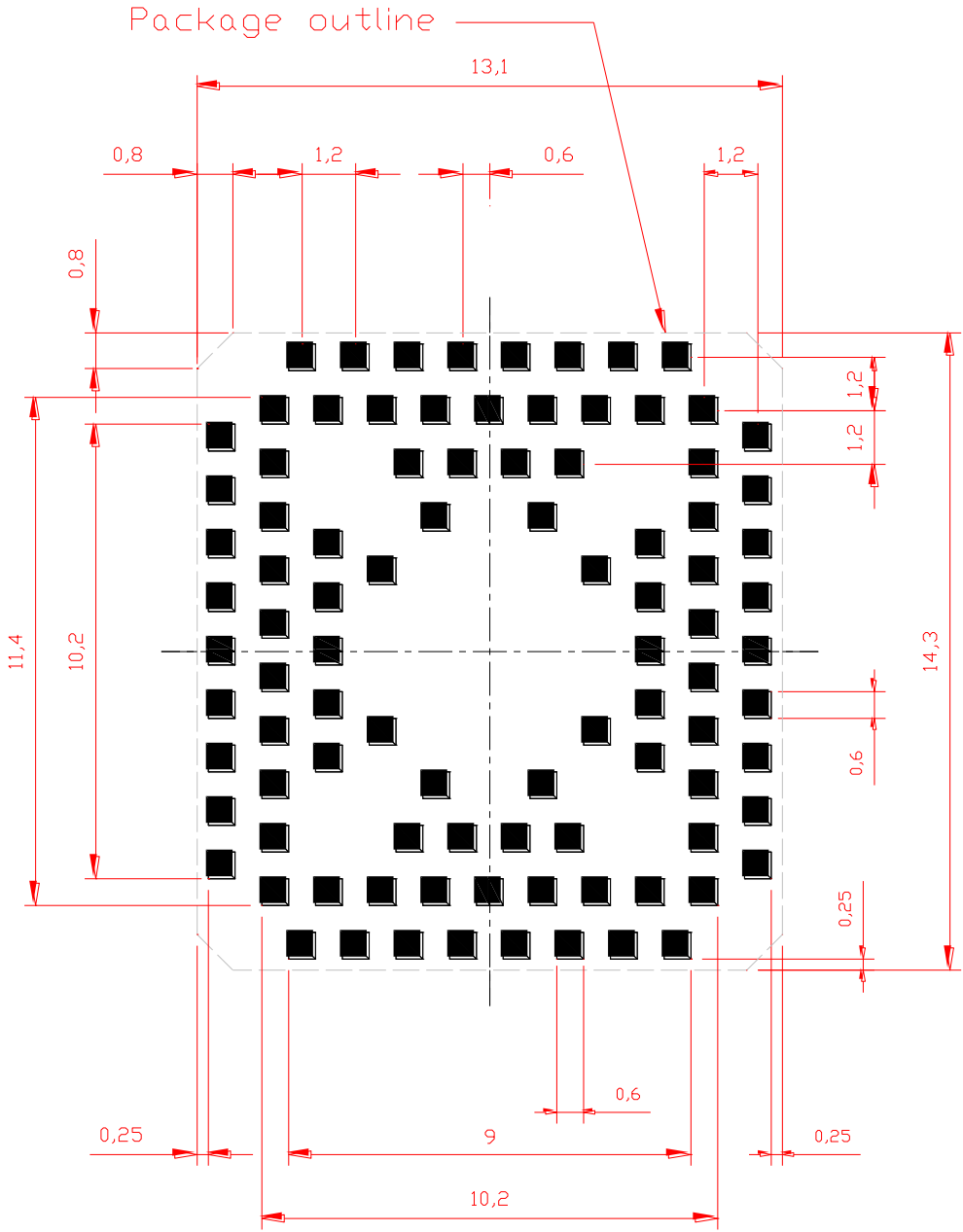

Figure 20: Copper Pattern (top view)

SOLDER RESIST PATTERN (top view)

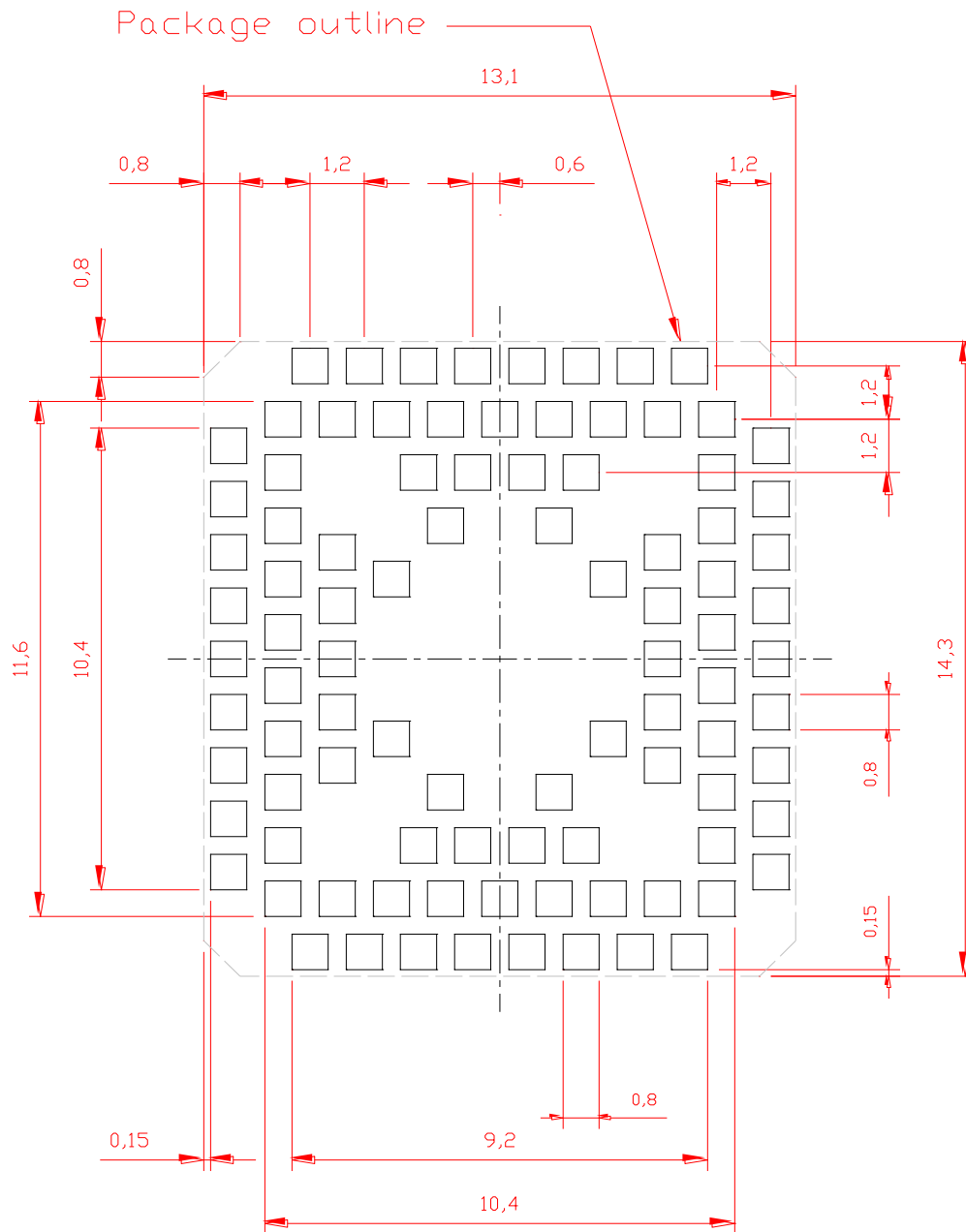

Figure 21: Solder resist pattern (top view)

10.1.2 ME310G1-WW, ME310G1-WWV, ME310G1-W2, and ME310G1-W3

COPPER PATTERN (top view)

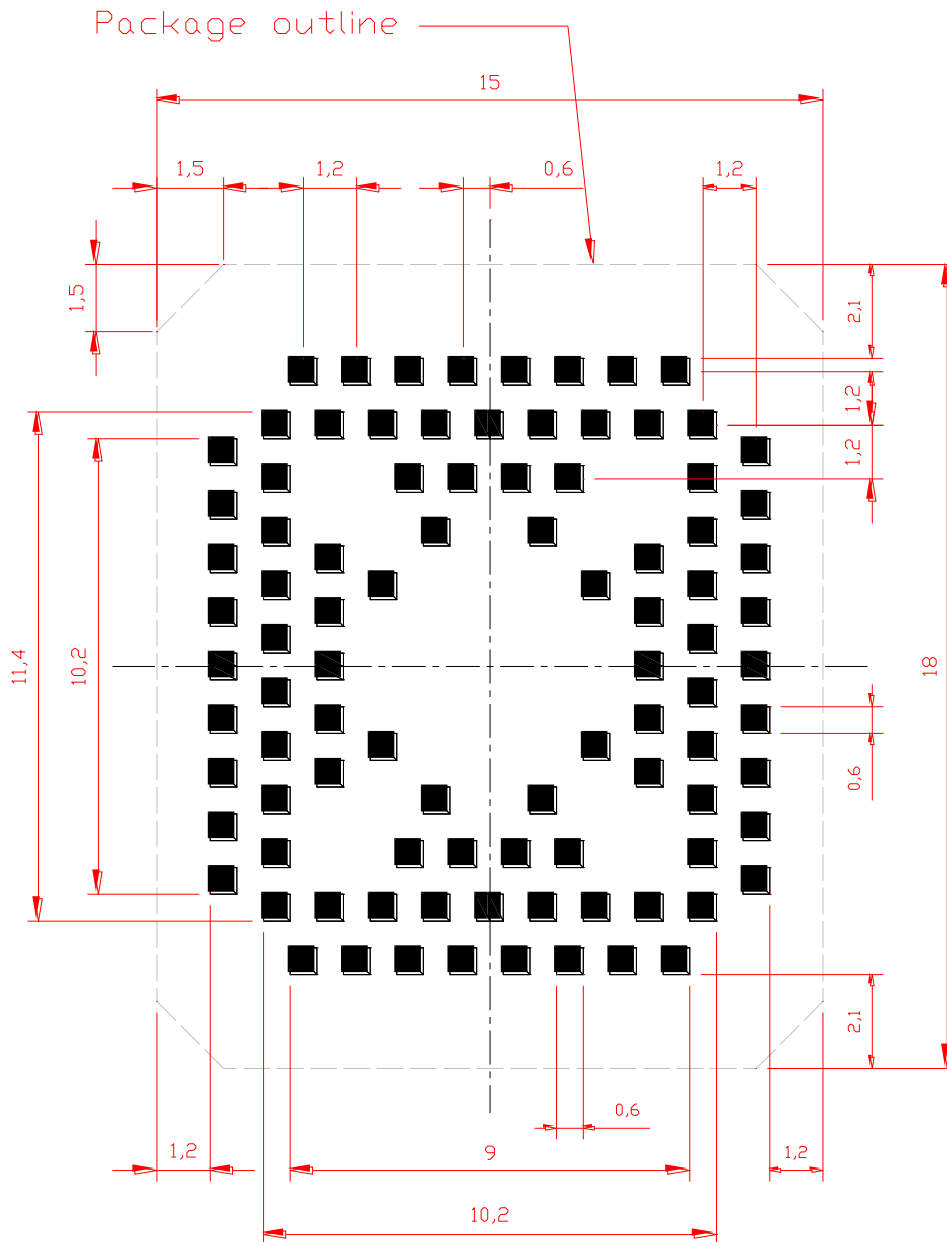

Figure 22: Example Figure

SOLDER RESIST PATTERN (top view)

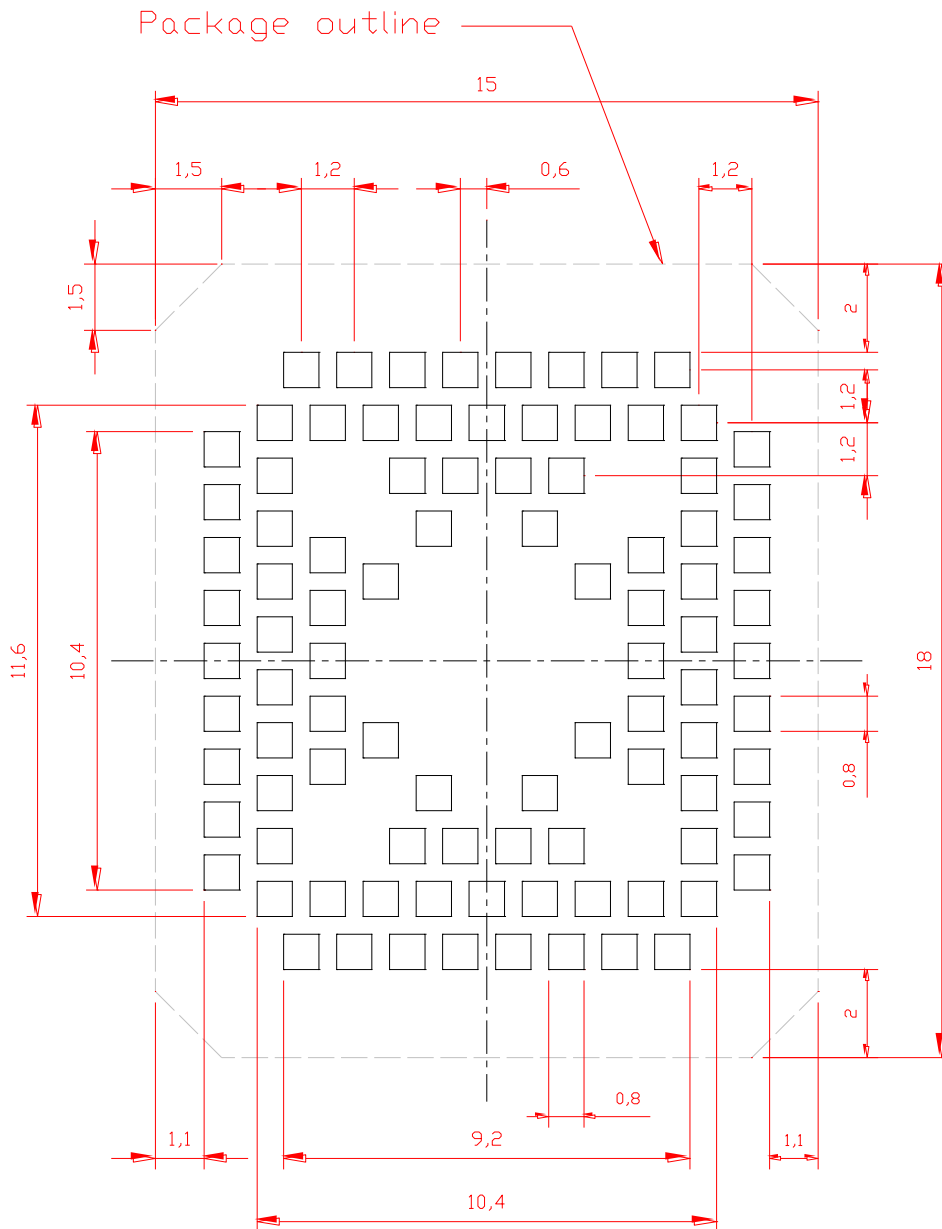

Figure 23: Example Figure

10.1.3 Recommendations for ME310G1-W1

This section illustrates the application positioning inhibit area for ME310G1 models W1. To facilitate reworking, the recommended placement is shown in figure below.

It is recommended to avoid contact of mechanical parts with an SMT component of the module.

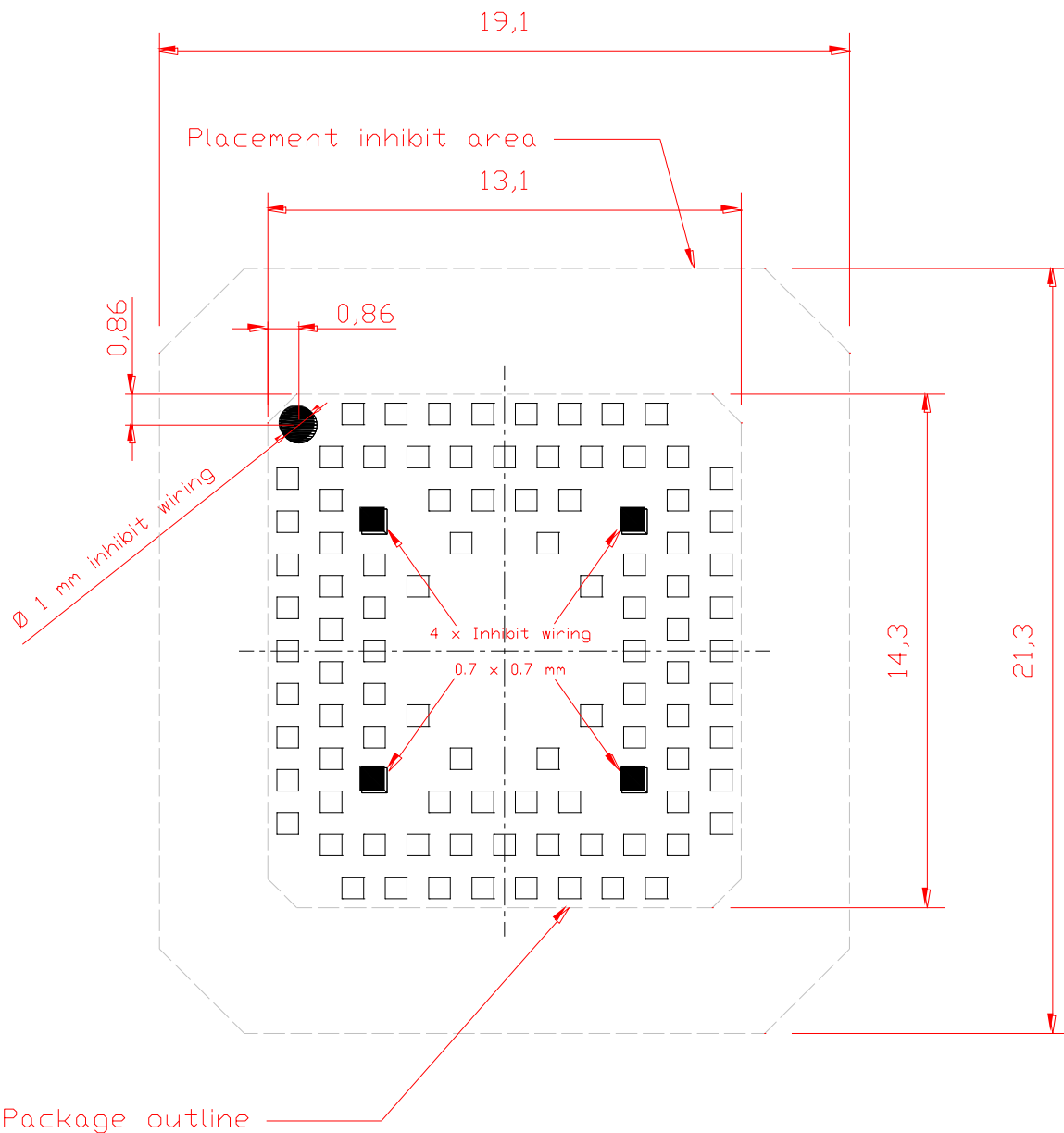

Figure 24: ME310G1-W1 Recommendations



Note: The region under **INHIBIT WIRING** must be clear from signal or ground paths.

10.1.4 Recommendations for ME310G1-WW, ME310G1-WWV, ME310G1-W2, and ME310G1-W3

This section illustrates the application placement inhibit area for the ME310G1 models WW, WWV, W2, and W3. To facilitate reworking, the recommended placement is shown in the figure below.

It is recommended to avoid contact of mechanical parts with a SMT component of the module.

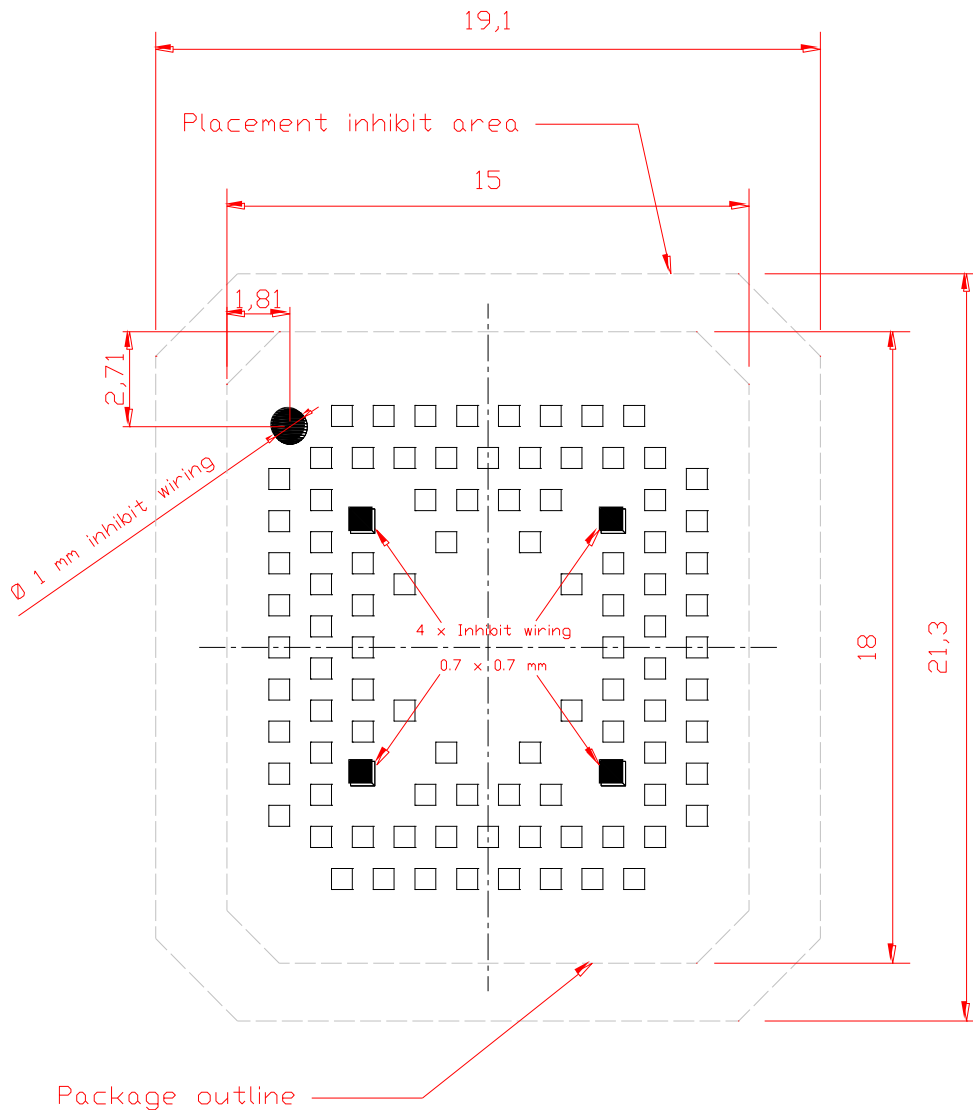

Figure 25: ME310G1-WW, ME310G1-WWV, ME310G1-W2, and ME310G1-W3 Recommendations



Note: The region under **INHIBIT WIRING** must be clear from signal or ground paths.

10.2 PCB Pad Design

The recommended PCB solder type is Non-solder mask defined (NSMD).

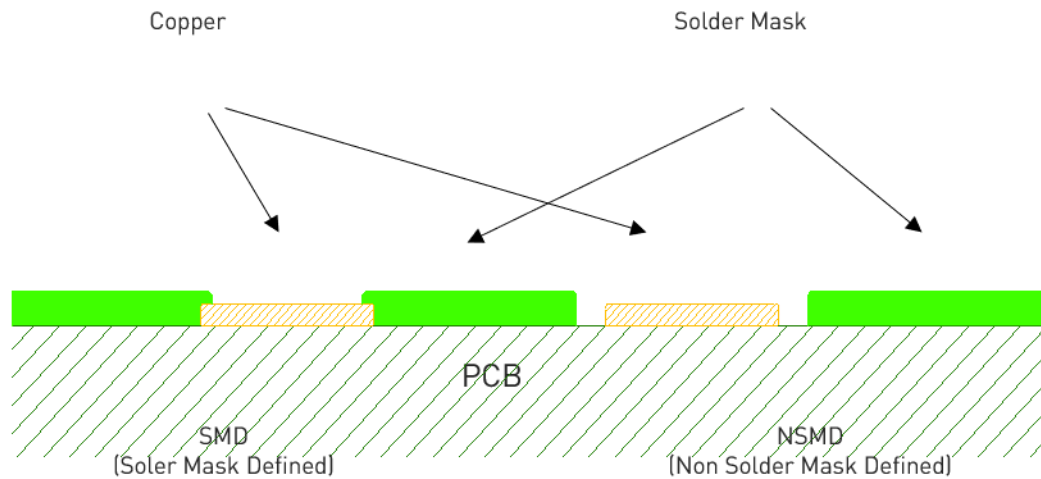

Figure 26: PCB solder pad recommendations

Recommended dimensions for PCB pads are 1:1, including the module pads.

It is not recommended to place via or micro-vias not covered by the solder resist in an area of 0.3 mm around the pads unless they are transmitting the same signal as the pad itself

Through holes in the pad are not allowed, only blind holes are allowed.

Recommended PCB pad surface:

Finish	Layer Thickness (um)	Properties
Electro-less Ni / Immersion Au	3 -7 / 0.03 - 0.15	good solder ability protection, high shear force values

Table 42 Recommended PCB pad surface

The PCB must be able to resist the high temperatures that occur during the lead-free process. This issue should be discussed with the PCB supplier. For best surface plating wettability, tin-lead solder paste must be used in place of lead-free solder paste.

It is not mandatory to panel the PCB of the application. If required, it is recommended to use milled contours and pre-drilled board breakouts. It is not recommended to use scoring or v-cut solutions.

10.3 Stencil

The layout of the stencil apertures can be the same as the recommended footprint (1:1). The recommended stencil foil thickness must be $\geq 120 \mu\text{m}$.

10.4 Solder Paste

Item	Lead Free
Solder Paste	Sn/Ag/Cu

Table 43: Solder paste

We recommend using only “no-clean” solder paste to avoid cleaning of the modules after assembly.

10.5 Solder Reflow

Recommended solder reflow profile:

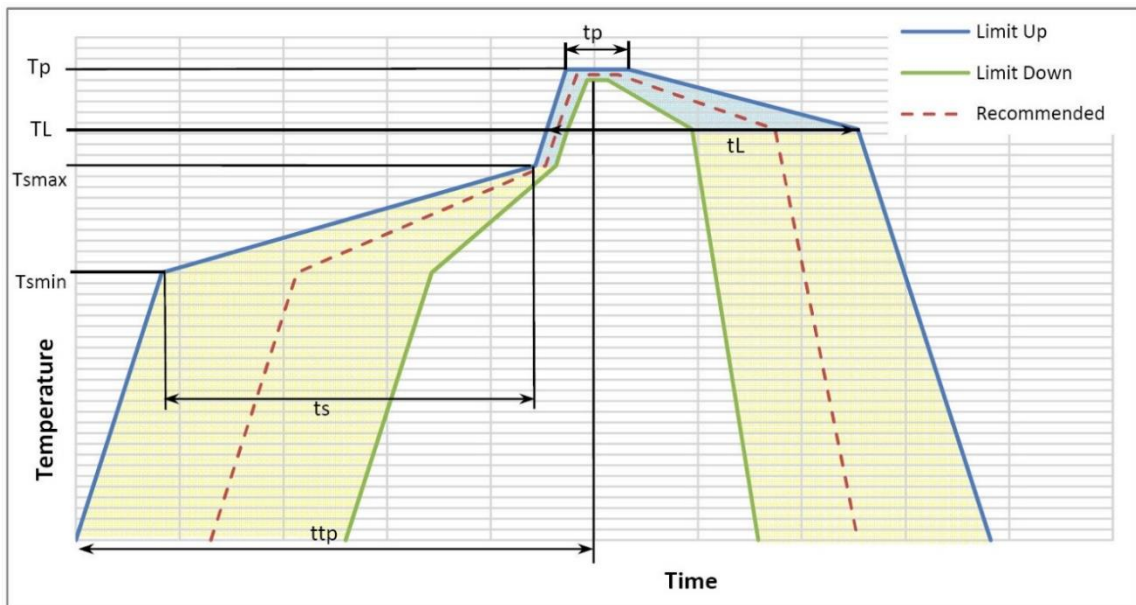

Figure 27: Recommended Solder reflow profile



Warning: The solder reflow profile represents the typical SAC reflow limits. It does not guarantee the proper adherence of the module to the customer’s application throughout the temperature range. The customer must optimize the reflow profile based on the factors such as thermal mass and warpage.

Profile Feature	Pb-Free Assembly
Average ramp-up rate (T_L to T_p)	3°C/second max
Preheat – Temperature Min (T_{smin}) – Temperature Max (T_{smax}) – Time (min to max) (t_s)	150°C 200°C 60-180 seconds
T_{smax} to T_L – Ramp-up Rate	3°C/second max

Profile Feature	Pb-Free Assembly
Time maintained above: – Temperature (TL) – Time (tL)	217°C 60-150 seconds
Peak Temperature (Tp)	245 +0/-5°C
Time within 5°C of actual Peak Temperature (tp)	10-30 seconds
Ramp-down Rate	6°C/second max.
Time 25°C to Peak Temperature	8 minutes max.

Table 44 Profile feature recommendations



Note: All temperatures refer to the topside of the package, measured on the package body surface.



Warning: The ME310G1 modules withstand one reflow process only.



Warning: The solder reflow profile represents the typical SAC reflow limits. It does not guarantee the proper adherence of the module to the customer's application throughout the temperature range. The customer must optimize the reflow profile based on the factors such as thermal mass and warpage.

11 PACKAGING

11.1 Tray

11.1.1 ME310G1-W1

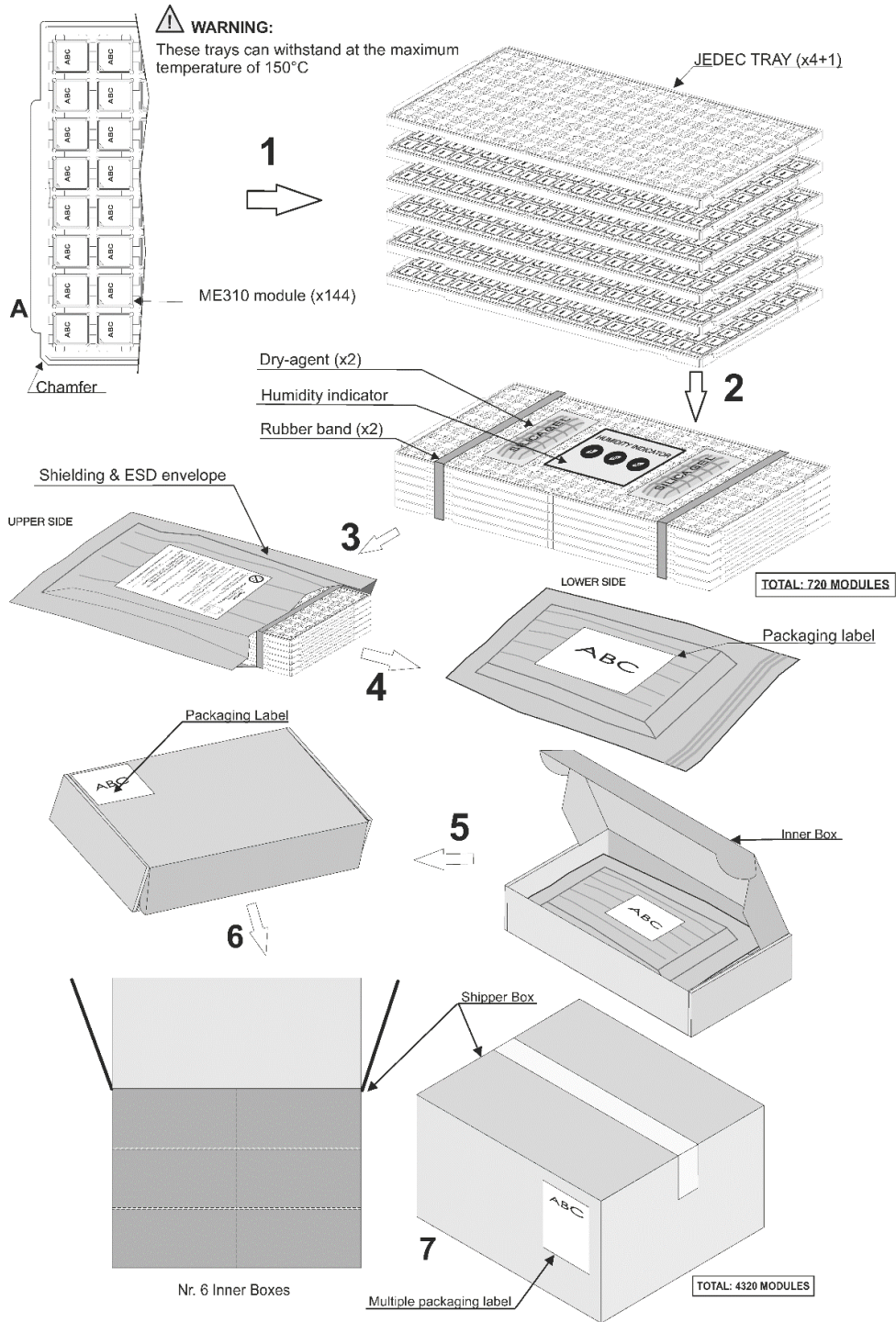

Figure 28: ME310G1-W1 tray packaging

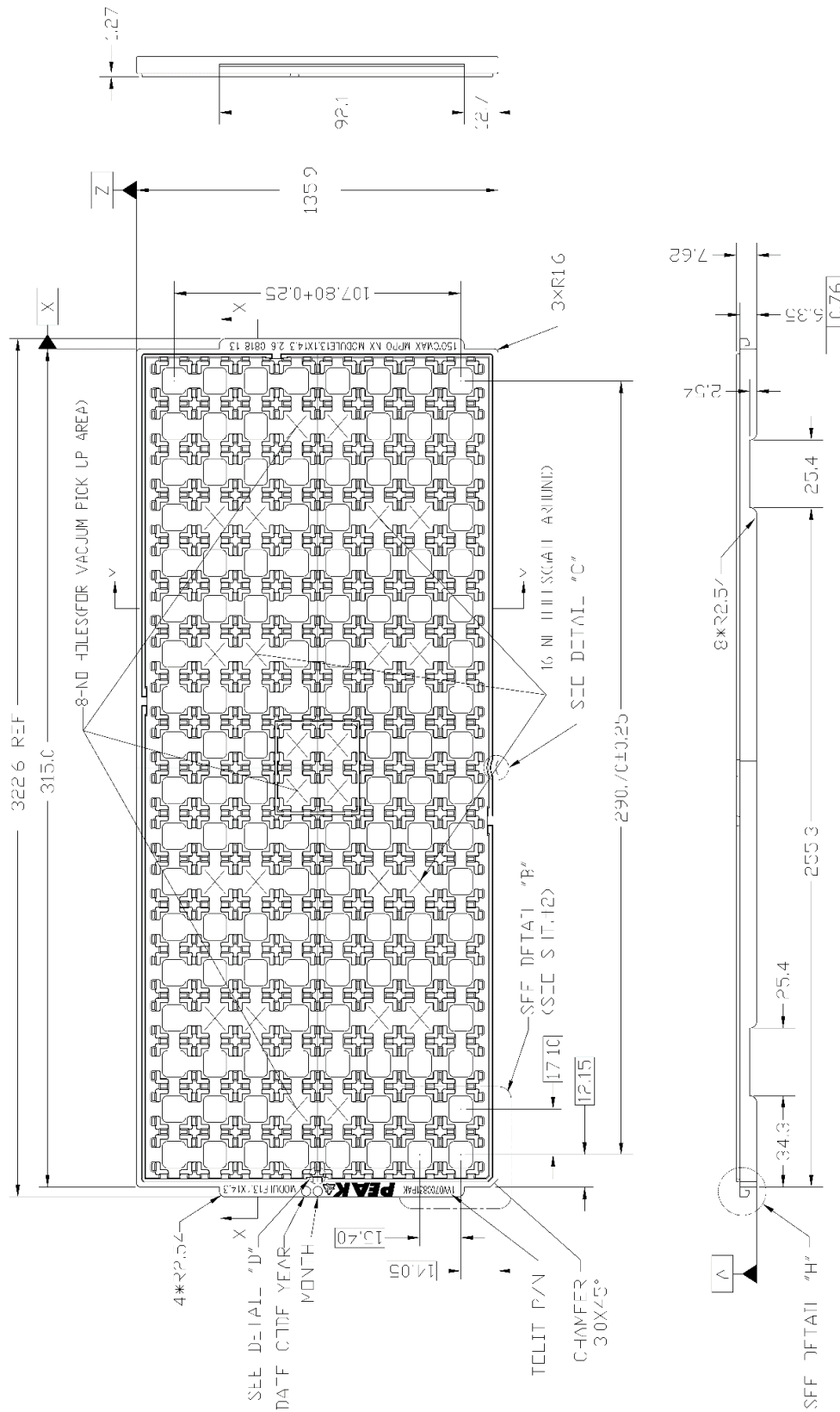

Figure 29: ME310G1-W1 tray

11.1.2 ME310G1-WW, ME310G1-W2, and ME310G1-W3

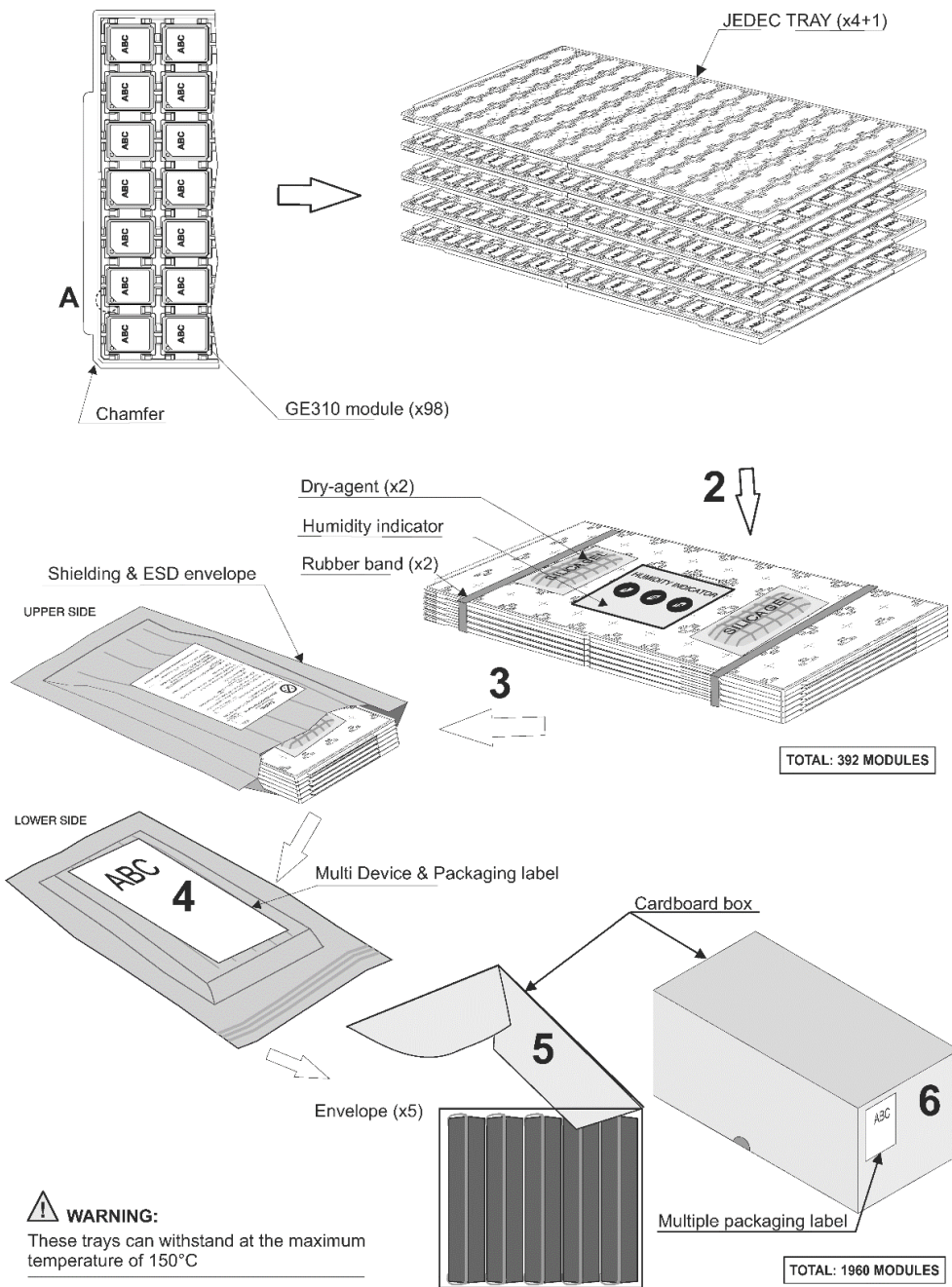

Figure 30: ME310G1-WW tray packaging

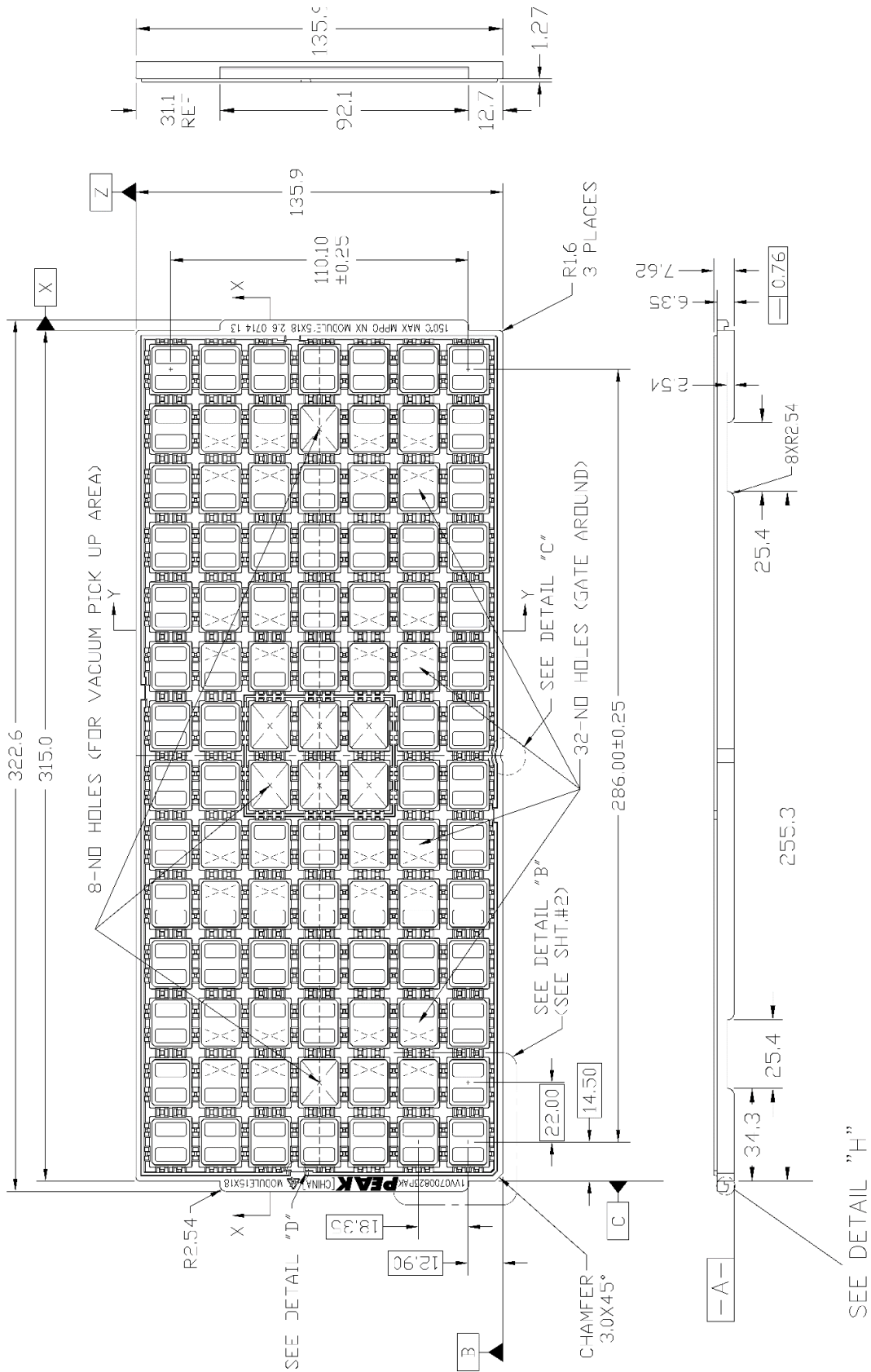

Figure 31: ME310G1-WW tray

11.2 Reel

11.2.1 ME310G1-W1

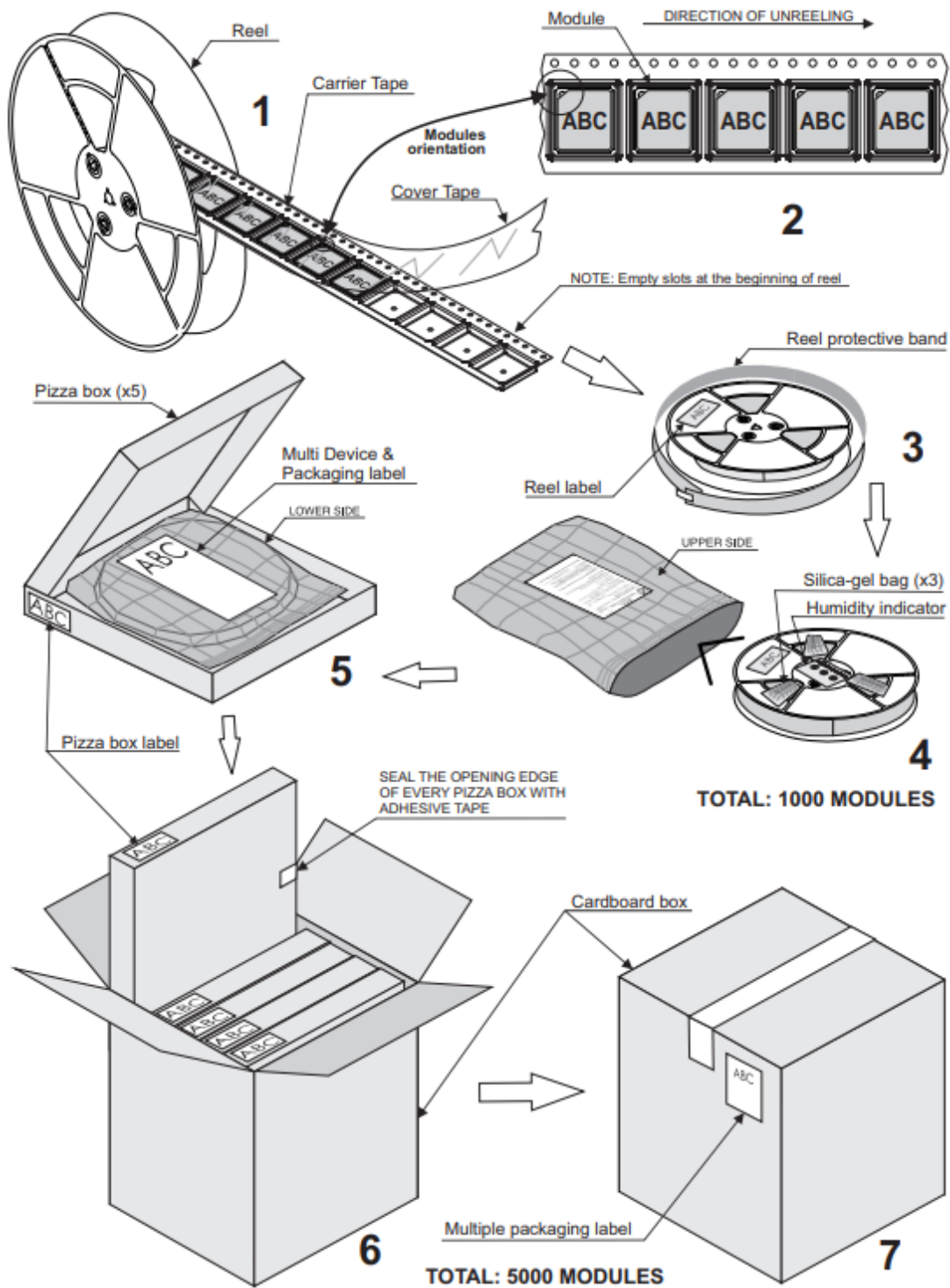

Figure 32: ME310G1-WW tray

11.2.2 ME310G1-WW, ME310G1-W2, and ME310G1-W3

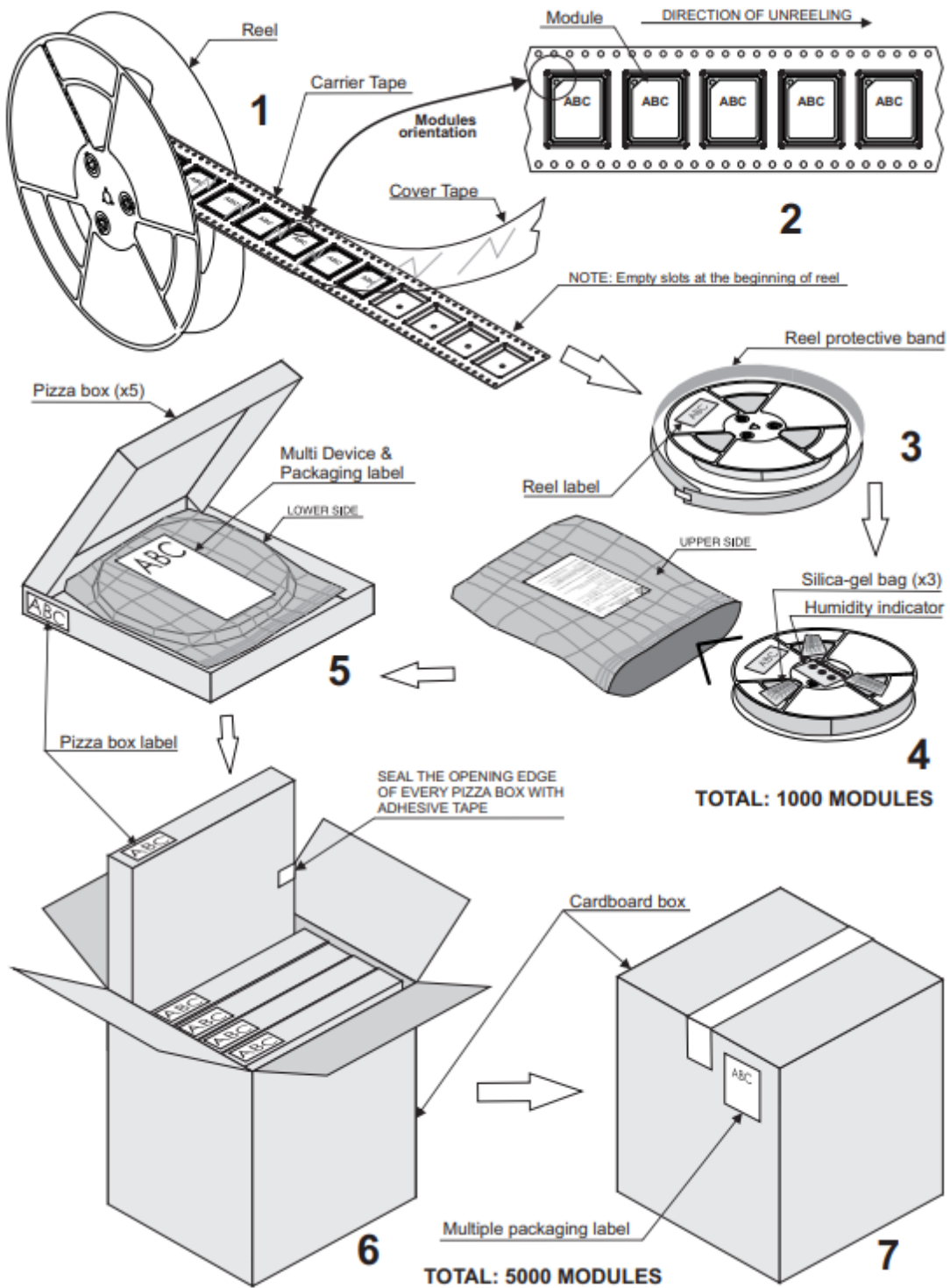

Figure 33: ME310G1-WW tray

11.3 Moisture Sensitivity

The ME310G1 is a level 3 Moisture Sensitive Device, in accordance with the standard IPC/JEDEC J-STD-020, it takes care of all related requirements for using this kind of components.

Moreover, the customer must take care of the following conditions:

- a)** Calculated shelf life in sealed bag: 12 months at <math><40^{\circ}\text{C}</math> and <math><90\%</math> relative humidity (RH).
- b)** Environmental condition during production: - c)** The maximum time between opening the sealed bag and the reflow process must be 168 hours if condition b) "IPC/JEDEC J-STD-033D paragraph 5.2" is respected
- d)** Baking is required if conditions b) or c) are not respected
- e)** Baking is required if the humidity indicator inside the bag indicates 10% RH or more

12 CONFORMITY ASSESSMENT ISSUES

12.1 Approvals Summary

Type Approval	ME310G1-W1	ME310G1-WW	ME310G1-WWV	ME310G1-W2	ME310G1-W3
EU RED / UKCA	Yes / Yes	Yes / Yes	Yes / In progress	Yes / Yes	In progress
US FCC	Yes	Yes	Yes	-	In Progress
CA ISED	Yes	Yes	Yes	-	In progress
BRAZIL ANATEL	-	Yes	-	-	
JAPAN JRF & JTBL	-	Yes	-	-	In progress
CHINA CCC	-	Yes	-	-	Yes
Singapore IMDA	Yes	Yes	-	-	
NCC Taiwan	-	Yes	-	-	

Table 45: Type approvals summary

12.2 Europe Approvals

12.2.1 RED Declaration of Conformity

Hereby, Telit Communications S.p.A declares that the ME310G1-W1, ME310G1-WW, ME310G1-WWV and ME310G1-W2 Modules comply with Directive 2014/53/EU.

The full text of the EU declaration of conformity is available at the following internet address: <https://www.telit.com/red>

Text of 2014/53/EU Directive (RED) can be found here: <https://eur-lex.europa.eu/legal-content/EN/TXT/?uri=CELEX:32014L0053>

12.2.2 UKCA Declaration of Conformity

Hereby, Telit Communications S.p.A declares that the ME310G1-W1, ME310G1-W2 and ME310G1-WW. Modules are in compliance with the Radio Equipment Regulations 2017 for UKCA.

The full text of the UKCA declaration of conformity is available at the following internet address: <https://www.telit.com/ukca>

The UKCA requirements can be found here:

<https://www.gov.uk/guidance/using-the-ukca-marking>

12.2.3 RED/UKCA Antennas

This radio transmitter has been approved under RED / UKCA to operate with the antenna types listed below with the maximum permissible gain indicated. The usage of a different antenna in the final hosting device may need a new assessment of host conformity to RED / UKCA.



Note: UCKA reference is valid only for ME310G1-W1, ME310G1-W2 and ME310G1-WW

Model	Antenna Type
ME310G1-W1	Omnidirectional Antenna Gain 2.14 dBi
ME310G1-WW	
ME310G1-WWV	
ME310G1-W2	
ME310G1-W3	

Table 46: RED / UKCA Antenna Type

Band	Max Gain for RED / UKCA (dBi)				
	ME310G1-W1	ME310G1-WW	ME310G1-WWV	ME310G1-W2	ME310G1-W3
GSM 900	---	---	8.48	---	---
DCS 1800	---	---	14.36	---	---
GPRS/EGPRS 1800	---	10.34	9.34	---	---
FDD 1	14.84	11.84	11.84	14.3	11.84
FDD 3	14.33	11.33	11.33	13.8	11.33
FDD 8	11.45	8.45	8.45	10.7	8.45
FDD 20	11.20	8.20	8.20	11.2	8.20
FDD 28	10.47	7.47	7.47	10.7	7.47
FDD 31	---	---	---	2.5	---
FDD 72	---	---	---	2.5	---

Table 47: Max Gain for RED / UKCA

12.3 FCC and ISED Approval/FCC et ISDE Approbation

12.3.1 FCC Certificates

The FCC Certificate is available here: <https://www.fcc.gov/oet/ea/fccid>

12.3.2 ISED Certificate / *ISDE Certificates*

The ISED Certificate is available here / *Le certificat ISDE est disponible ici: <https://sms-sgs.ic.gc.ca/equipmentSearch/searchRadioEquipments?execution=e1s1&lang=en>*

12.3.3 Applicable FCC and ISED Rules / *Liste des Règles FCC et ISDE Applicables*

Model <i>Modèle</i>	Applicable FCC Rules	Applicable ISED Rules <i>Règles ISDE applicables</i>
ME310G1-W1	47 CFR Part 2, 22, 24, 27, 90	RSS: 132 Issue3, 133 Issue 6, 130 Issue 2, 139 Issue 3; RSS-Gen Issue 5
ME310G1-WW		
ME310G1-WWV		
ME310G1-W3		

Table 48: *Applicable FCC and ISED rules*

12.3.4 FCC and ISED Regulatory Notices / *Avis Réglementaires de FCC et ISDE*

Modification statement / *Déclaration de modification*

Telit does not approve any changes or modifications to this device by the user. Any changes or modifications could void the user's authority to operate the equipment.

Telit n'approuve aucune modification apportée à l'appareil par l'utilisateur, quelle qu'en soit la nature. Tout changement ou modification peuvent annuler le droit d'utilisation de l'appareil par l'utilisateur.

Interference statement / *Déclaration d'interférence*

This device complies with Part 15 of the FCC Rules and Industry Canada licence-exempt RSS standard(s). Operation is subject to the following two conditions: (1) this device may not cause interference, and (2) this device must accept any interference, including interference that may cause undesired operation of the device.

Le présent appareil est conforme aux CNR d'Industrie Canada applicables aux appareils radio exempts de licence. L'exploitation est autorisée aux deux conditions suivantes : (1) l'appareil ne doit pas produire de brouillage, et (2) l'utilisateur de l'appareil doit accepter tout brouillage radioélectrique subi, même si le brouillage est susceptible d'en compromettre le fonctionnement.

Wireless notice / *Wireless avis*

This device complies with FCC/ISED radiation exposure limits set forth for an uncontrolled environment and meets the FCC radio frequency (RF) Exposure Guidelines

and RSS-102 of the ISED radio frequency (RF) Exposure rules. This transmitter must not be co-located or operate in conjunction with any other antenna or transmitter. The antenna should be installed and operated with a minimum distance of 20 cm between the radiator and your body.

Le présent appareil est conforme à l'exposition aux radiations FCC / ISED définies pour un environnement non contrôlé et répond aux directives d'exposition de la fréquence de la FCC radiofréquence (RF) et RSS-102 de la fréquence radio (RF) ISED règles d'exposition. L'émetteur ne doit pas être colocalisé ni fonctionner conjointement avec à autre antenne ou autre émetteur. L'antenne doit être installée de façon à garder une distance minimale de 20 centimètres entre la source de rayonnements et votre corps.

FCC Class B digital device notice (FCC only)

This equipment has been tested and found to comply with the limits for a Class B digital device, according to part 15 of the FCC Rules. These limits are designed to provide reasonable protection against harmful interference in a residential installation. This equipment generates, uses, and can radiate radio frequency energy and, if not installed and used per the instructions, may cause harmful interference to radio communications. However, there is no guarantee that interference will not occur in a particular installation. If this equipment does cause harmful interference to radio or television reception, which can be determined by turning the equipment off and on, the user is encouraged to try to correct the interference by taking one or more of the following measures:

Reorient or relocate the receiving antenna.

- Increase the separation between the equipment and the receiver.
- Connect the equipment into an outlet on a circuit different from that to which the receiver is connected.
- Consult the dealer or an experienced radio/TV technician for help.

CAN ICES-3 (B) / NMB-3 (B) (ISED only) / (ISDE seulement)

This Class B digital apparatus complies with Canadian ICES-003.

Cet appareil numérique de classe B est conforme à la norme canadienne ICES-003.

12.3.5 FCC/ISED Antennas / FCC/ISDE Antennes

FCC

This radio transmitter has been approved by FCC and ISED to operate with the antenna types listed below with the maximum allowable gain indicated. Antenna types not

included in this list, with a gain greater than the maximum gain indicated for that type, are strictly prohibited from use with this device.

Model	Antenna Type
ME310G1-W1	Omnidirectional Antenna Gain 2.14 dBi
ME310G1-WW	
ME310G1-WWV	
ME310G1-W3	

Table 49: FCC Antenna Type

Band	Max Gain for FCC (dBi)			
	ME310G1-W1	ME310G1-WW	ME310G1-WWV	ME310G1-W3
GSM 850	---	---	6.6	---
GSM 1900	---	---	2.0	---
GPRS/EGPRS 850	---	6.9	6.9	---
GPRS/EGPRS 1900	---	2.5	2.5	---
FDD 2	11.0	8.0	8.0	8.0
FDD 4	8.0	5.0	5.0	5.0
FDD 5	12.4	9.4	9.4	9.4
FDD 12	11.6	8.6	8.6	8.6
FDD 13	12.1	9.1	9.1	9.1
FDD 14				
FDD 25	11.0	8.0	8.0	8.0
FDD 26	12.3	9.3	9.3	9.3
FDD 66	8.0	5.0	5.0	5.0
FDD 71	11.4	11.4	11.4	---
FDD 85	11.6	8.6	8.6	8.6
FDD 86	12.1	9.1	---	---
FDD 8_39d	11.9	8.9	---	8.9

Table 50: Max Gain for FCC (dBi)

ISED / ISDE

This radio transmitter has been approved by ISED to operate with the antenna types listed below with the maximum allowable gain indicated. Antenna types not included in this list, with a gain greater than the maximum gain indicated for that type, are strictly prohibited from use with this device.

Le présent émetteur radio a été approuvé par ISDE pour fonctionner avec les types d'antenne énumérés ci-dessous et ayant un gain admissible maximal. Les types d'antenne non inclus dans cette liste, et dont le gain est supérieur au gain maximal indiqué, sont strictement interdits pour l'exploitation de l'émetteur.

Model <i>Modèle</i>	Antenna Type <i>Type d'Antenne</i>
ME310G1-W1	Omnidirectional Antenna Gain 2.14 dBi <i>Omnidirectionelle Gain de l'antenne 2.14 dBi</i>
ME310G1-WW	
ME310G1-WWW	
ME310G1-W3	

Table 51: ISED Antenna Type

Gain maximum for ISED (dBi) / <i>Gain maximum pour ISDE (dBi)</i>				
Band	ME310G1-W1	ME310G1-WW	ME310G1-WWW	ME310G1-W3
GSM 850	---	---	6.1	---
GSM 1900	---	---	2.0	---
GPRS/EGPRS 850	---	3.6	3.6	---
GPRS/EGPRS 1900	---	2.5	2.5	---
FDD 2	11.0	8.0	8.0	8.0
FDD 4	8.0	5.0	5.0	5.0
FDD 5	9.1	6.1	6.1	6.1
FDD 12	8.6	5.6	5.6	5.6
FDD 13	8.9	5.9	5.9	6.0
FDD 14				6.0
FDD 25	11.0	8.0	8.0	8.0
FDD 26	9.0	6.0	6.0	6.2
FDD 66	8.0	5.0	5.0	5.0
FDD 71	8.4	8.4	8.4	---
FDD 85	8.6	5.6	5.6	5.6

Table 52: Gain maximum for ISED (dBi)

12.3.6 FCC label and Compliance Information

The product has an FCC ID label on the device itself. In addition, the OEM host end product manufacturer will be informed to display a label referring to the enclosed module. The external label will read as follows:

“Contains Transmitter Module FCC ID: RI7ME310G1W1” or “Contains FCC ID: RI7ME310G1W1” for ME310G1-W1

“Contains Transmitter Module FCC ID: RI7ME310G1WW” or “Contains FCC ID: RI7ME310G1WW” for ME310G1-WW and ME310G1-WWV

“Contains Transmitter Module FCC ID: RI7ME310G1W3” or “Contains FCC ID: RI7ME310G1W3” for ME310G1-W3

Below list of all the models and related FCC ID:

Model	FCC ID
ME310G1-W1	RI7ME310G1W1
ME310G1-WW	RI7ME310G1WW
ME310G1-WWV	
ME310G1-W3	RI7ME310G1W3

Table 53: FCC ID

12.3.7 ISED Label and Compliance Information/ *Étiquette et Informations de Conformité ISDE*

The host product shall be properly labeled to identify the modules within the host product.

The ISED certification label of a module shall be visible at all times when installed in the host product; otherwise, the host product must be labeled to display the ISED certification number for the module, preceded by the word "contains" or similar wording expressing the same meaning, as follows:

Contains IC: XXXXXX-YYYYYYYYYYY

In this case, XXXXXX-YYYYYYYYYYY is the module's certification number.

Le produit hôte devra être correctement étiqueté, de façon à permettre l'identification des modules qui s'y trouvent.

L'étiquette d'homologation d'un module d'ISDE devra être apposée sur le produit hôte à un endroit bien en vue, en tout temps. En l'absence d'étiquette, le produit hôte doit porter une étiquette sur laquelle figure le numéro d'homologation du module d'ISDE, précédé du mot « contient », ou d'une formulation similaire allant dans le même sens et qui va comme suit:

Contient IC : XXXXXX-YYYYYYYYYYY

Dans ce cas, XXXXXX-YYYYYYYYYYY est le numéro d'homologation du module.

Model <i>Modèle</i>	ISED Certification Number <i>Num. de certification ISDE</i>
ME310G1-W1	5131A-ME310G1W1
ME310G1-WW	5131A-ME310G1WW
ME310G1-WWV	
ME310G1-W3	5141A-ME310G1W3

Table 54: ISED Certification Number

12.3.8 Information on Test Modes and Additional Testing Requirements/*Informations sur les Modes de Test et les Exigences de Test Supplémentaires*

The module has been evaluated in mobile stand-alone conditions. For different operational conditions other than a stand-alone modular transmitter in a host (multiple, simultaneously transmitting modules or other transmitters in a host), additional testing may be required (collocation, retesting...). If this module is intended for use in a portable device, the user is responsible for separate approval to meet the SAR requirements of FCC Part 2.1093 and IC RSS-102.

Le module a été évalué dans des conditions autonomes mobiles. Pour différentes conditions de fonctionnement d'un émetteur modulaire autonome dans un hôte (plusieurs modules émettant simultanément ou d'autres émetteurs dans un hôte), des tests supplémentaires peuvent être nécessaires (colocalisation, retesting...) Si ce module est destiné à être utilisé dans un appareil portable, vous êtes responsable de l'approbation séparée pour satisfaire aux exigences SAR de la FCC Partie 2.1093 et IC RSS-102.

12.3.9 FCC Additional Testing, Part 15 Subpart B Disclaimer

The modular transmitter is only FCC authorized for the specific rule parts (i.e., FCC transmitter rules) listed on the license, and that the host product manufacturer is responsible for compliance with any other FCC rules that apply to the host not covered by the modular transmitter grant of certification. If the beneficiary markets his product as compliant with Part 15 Subpart B (when it also contains unintentional-radiator digital circuitry), then the beneficiary must communicate that the final host product still requires compliance tests of Part 15 Subpart B with the modular transmitter installed. The end product with an embedded module may also need to pass the FCC Part 15 unintentional emission testing requirements and be properly authorized following FCC Part 15.

12.4 ANATEL Regulatory Notices



"Este equipamento não tem direito à proteção contra interferência prejudicial e não pode causar interferência em sistemas devidamente autorizados"

"This equipment is not entitled to protection against harmful interference and must not cause interference in duly authorized systems"

ME910G1-WW, ME310G1-WW, ML865G1-WW Homologation #: 08566-20-02618

12.5 NCC Regulatory Notices

According to NCC Taiwan requirements, the module and the packaging shall be identified as described in the following lines. Shall be added also the specified safety warning statement.

Brand name: Telit

Model name: ME310G1-WW

Equipment name: WWAN module

NCC logo: 

NCC ID: CCAF21Y00040

NCC safety warning statement: “減少電磁波影響，請妥適使用”NCC Note: 注意：行動電話業務(2G)於106年6月停止提供服務後，本設備2G功能在國內將無法使用。

12.6 JRL/JTBL Regulatory Notices

According to Japanese JRL/JTBL requirements, the module and the packaging shall display the conformity mark, showing that the terminal equipment has received the certification. Due to the very small size of the ME310G1-WW and the difficulties to affix the mark, the conformity mark is displayed only in the packaging and in the picture below:

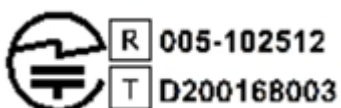

13 PRODUCT AND SAFETY INFORMATION

13.1 Copyrights and Other Notices

SPECIFICATIONS ARE SUBJECT TO CHANGE WITHOUT NOTICE

Although reasonable efforts have been made to ensure the accuracy of this document, Telit assumes no liability resulting from any inaccuracies or omissions in this document, or from the use of the information contained herein. The information contained in this document has been carefully checked and is believed to be reliable. Telit reserves the right to make changes to any of the products described herein, to revise it and to make changes from time to time without any obligation to notify anyone of such revisions or changes. Telit does not assume any liability arising from the application or use of any product, software, or circuit described herein; neither does it convey license under its patent rights or the rights of others.

This document may contain references or information about Telit products (machines and programs), or services that are not announced in your country. Such references or information do not necessarily mean that Telit intends to announce such Telit products, programming, or services in your country.

13.1.1 Copyrights

This instruction manual and the Telit products described herein may include or describe Telit copyrighted material, such as computer programs stored in semiconductor memories or other media. The laws in Italy and in other countries reserve to Telit and its licensors certain exclusive rights for copyrighted material, including the exclusive right to copy, reproduce in any form, distribute and make derivative works of the copyrighted material. Accordingly, any of Telit's or its licensors' copyrighted material contained herein or described in this instruction manual, shall not be copied, reproduced, distributed, merged or modified in any way without the express written permission of the owner. Furthermore, the purchase of Telit products shall not be deemed to grant in any way, neither directly nor by implication, or estoppel, any license.

13.1.2 Computer Software Copyrights

Telit and the Third Party supplied Software (SW) products, described in this instruction manual may include Telit's and other Third Party's copyrighted computer programs stored in semiconductor memories or other media. The laws in Italy and in other countries reserve to Telit and other Third Party, SW exclusive rights for copyrighted

computer programs, including – but not limited to – the exclusive right to copy or reproduce in any form the copyrighted products. Accordingly, any copyrighted computer programs contained in Telit’s products described in this instruction manual shall not be copied (reverse engineered) or reproduced in any manner without the express written permission of the copyright owner, being Telit or the Third-Party software supplier. Furthermore, the purchase of Telit products shall not be deemed to grant either directly or by implication, estoppel, or in any other way, any license under the copyrights, patents or patent applications of Telit or other Third Party supplied SW, except for the normal non-exclusive, royalty free license to use arising by operation of law in the sale of a product.

13.2 Usage and Disclosure Restrictions

13.2.1 License Agreements

The software described in this document is owned by Telit and its licensors. It is furnished by express license agreement only and shall be used exclusively in accordance with the terms of such agreement.

13.2.2 Copyrighted Materials

The Software and the documentation are copyrighted materials. Making unauthorized copies is prohibited by the law. The software or the documentation shall not be reproduced, transmitted, transcribed, even partially, nor stored in a retrieval system, nor translated into any language or computer language, in any form or by any means, without prior written permission of Telit.

13.2.3 High-Risk Materials

Components, units, or third-party goods used in the making of the product described herein are NOT fault-tolerant and are NOT designed, manufactured, or intended for use as on-line control equipment in the following hazardous environments requiring fail-safe controls: operations of Nuclear Facilities, Aircraft Navigation or Aircraft Communication Systems, Air Traffic Control, Life Support, or Weapons Systems (“High Risk Activities”). Telit and its supplier(s) specifically disclaim any expressed or implied warranty of fitness eligibility for such High-Risk Activities.

13.2.4 Trademarks

TELIT and the Stylized T-Logo are registered in the Trademark Office. All other product or service names are property of their respective owners.

13.2.5 Third Party Rights

The software may include Third Party's software Rights. In this case the user agrees to comply with all terms and conditions imposed in respect of such separate software rights. In addition to Third Party Terms, the disclaimer of warranty and limitation of liability provisions in this License, shall apply to the Third Party Rights software as well.

TELIT HEREBY DISCLAIMS ANY AND ALL WARRANTIES EXPRESSED OR IMPLIED FROM ANY THIRD PARTY REGARDING ANY SEPARATE FILES, ANY THIRD PARTY MATERIALS INCLUDED IN THE SOFTWARE, ANY THIRD PARTY MATERIALS FROM WHICH THE SOFTWARE IS DERIVED (COLLECTIVELY "OTHER CODES"), AND THE USE OF ANY OR ALL OTHER CODES IN CONNECTION WITH THE SOFTWARE, INCLUDING (WITHOUT LIMITATION) ANY WARRANTIES OF SATISFACTORY QUALITY OR FITNESS FOR A PARTICULAR PURPOSE.

NO THIRD PARTY LICENSORS OF OTHER CODES MUST BE LIABLE FOR ANY DIRECT, INDIRECT, INCIDENTAL, SPECIAL, EXEMPLARY, OR CONSEQUENTIAL DAMAGES (INCLUDING WITHOUT LIMITATION LOST OF PROFITS), HOWEVER CAUSED AND WHETHER MADE UNDER CONTRACT, TORT OR OTHER LEGAL THEORY, ARISING IN ANY WAY OUT OF THE USE OR DISTRIBUTION OF THE OTHER CODES OR THE EXERCISE OF ANY RIGHTS GRANTED UNDER EITHER OR BOTH THIS LICENSE AND THE LEGAL TERMS APPLICABLE TO ANY SEPARATE FILES, EVEN IF ADVISED OF THE POSSIBILITY OF SUCH DAMAGES.

13.2.6 Waiver of Liability

IN NO EVENT WILL TELIT AND ITS AFFILIATES BE LIABLE FOR ANY DIRECT, INDIRECT, SPECIAL, GENERAL, INCIDENTAL, CONSEQUENTIAL, PUNITIVE OR EXEMPLARY INDIRECT DAMAGE OF ANY KIND WHATSOEVER, INCLUDING BUT NOT LIMITED TO REIMBURSEMENT OF COSTS, COMPENSATION OF ANY DAMAGE, LOSS OF PRODUCTION, LOSS OF PROFIT, LOSS OF USE, LOSS OF BUSINESS, LOSS OF DATA OR REVENUE, WHETHER OR NOT THE POSSIBILITY OF SUCH DAMAGES COULD HAVE BEEN REASONABLY FORESEEN, CONNECTED IN ANY WAY TO THE USE OF THE PRODUCT/S OR TO THE INFORMATION CONTAINED IN THE PRESENT DOCUMENTATION, EVEN IF TELIT AND/OR ITS AFFILIATES HAVE BEEN ADVISED OF THE POSSIBILITY OF SUCH DAMAGES OR THEY ARE FORESEEABLE OR FOR CLAIMS BY ANY THIRD PARTY.

13.3 Safety Recommendations

Make sure the use of this product is allowed in your country and in the environment required. The use of this product may be dangerous and has to be avoided in areas where:

- it can interfere with other electronic devices, particularly in environments such as hospitals, airports, aircrafts, etc.
- there is a risk of explosion such as gasoline stations, oil refineries, etc. It is the responsibility of the user to enforce the country regulation and the specific environment regulation.

Do not disassemble the product; any mark of tampering will compromise the warranty validity. We recommend following the instructions of the hardware user guides for correct wiring of the product. The product has to be supplied with a stabilized voltage source and the wiring has to be conformed to the security and fire prevention regulations. The product has to be handled with care, avoiding any contact with the pins because electrostatic discharges may damage the product itself. Same cautions have to be taken for the SIM, checking carefully the instruction for its use. Do not insert or remove the SIM when the product is in power saving mode.

The system integrator is responsible for the functioning of the final product. Therefore, the external components of the module, as well as any project or installation issue, have to be handled with care. Any interference may cause the risk of disturbing the GSM network or external devices or having an impact on the security system. Should there be any doubt, please refer to the technical documentation and the regulations in force. Every module has to be equipped with a proper antenna with specific characteristics. The antenna has to be installed carefully in order to avoid any interference with other electronic devices and has to guarantee a minimum distance from the body (20 cm). In case this requirement cannot be satisfied, the system integrator has to assess the final product against the SAR regulation.

The equipment is intended to be installed in a restricted area location.

The equipment must be supplied by an external specific limited power source in compliance with the standard EN 62368-1:2014.

The European Community provides some Directives for the electronic equipment introduced on the market. All of the relevant information is available on the European Community website:

https://ec.europa.eu/growth/sectors/electrical-engineering_en

14 GLOSSARY

ADC	Analog – Digital Converter
CLK	Clock
CMOS	Complementary Metal – Oxide Semiconductor
CS	Chip Select
DAC	Digital – Analog Converter
DTE	Data Terminal Equipment
DVI	Digital Voice Interface
ESR	Equivalent Series Resistance
GPIO	General Purpose Input Output
HS	High Speed
HSDPA	High Speed Downlink Packet Access
HSIC	High Speed Inter Chip
HSUPA	High Speed Uplink Packet Access
I/O	Input Output
MISO	Master Input – Slave Output
MOSI	Master Output – Slave Input
PCB	Printed Circuit Board
RTC	Real Time Clock
SIM	Subscriber Identification Module
SPI	Serial Peripheral Interface
TTSC	Telit Technical Support Centre
UART	Universal Asynchronous Receiver Transmitter
UMTS	Universal Mobile Telecommunication System
USB	Universal Serial Bus
VNA	Vector Network Analyzer
VSWR	Voltage Standing Wave Ratio
WCDMA	Wideband Code Division Multiple Access

15 DOCUMENT HISTORY

Revision	Date	Changes
17	2021-11-17	Added ME310G1-W3 for worldwide market
16	2021-10-27	UKCA reference for ME310G1-WW added
15	2021-09-24	Chap 6.1.2 added Chap 11.6 added UCKA reference only for ME310G1-W1, ME310G1-W2 Language reviewed
14	2021-08-19	Revision released for certification purpose. Not distributed. UKCA certification added
13	2021-08-05	Added B86 for WW Chapter 12, updated
12	2021-06-08	Added ME310G1-W3 for Korea market Added Section 5.14 for Antenna Tuner solution
11	2021-04-28	Section 12.5, added NCC Regulatory Notices Section 8.4, measurements update Section 2.2 and 2.5 added B86 Section 12.3 added B86 FCC antenna info Added B8_39d (US 900Mhz band) to W1 and WW products
10	2021-01-12	Reviewed template design and styles Section 12.2 updated with ME310G1-W2 information Section 11.2 updated with Reel information Section 7.2 removed Chapter 4 update
8	2020-09-14	Added ME310G1-W2 variant Section 2.5, TX Power update Section 2.8, Temperature ranges update Section 5.2, Power-on timing change back to 5sec
7	2020-07-22	Conformity assessment update with ANATEL
6	2020-05-19	Power consumption update (GPS) Conformity assessment update Added ME310G1-WWV variant
5	2020-04-29	Power consumption figures update FORCED_USB_BOOT renamed ROM_BOOT

		<p>Added USB signals in PIN ALLOCATION</p> <p>Added "WARNING" RXD1 in PIN ALLOCATION and in section 5.6.3.2</p> <p>Footprint update in section 10.1</p> <p>Added Packaging Tray information</p> <p>Added GNSS and LTE coexistence suggestion</p> <p>VBATmin update in section 4.1</p>
4	2020-01-31	<p>Power consumption figures update</p> <p>RX Sensitivity figures update</p> <p>HW Shutdown update</p> <p>Conformity assessment update</p>
3	2019-10-02	<p>Power consumption figures update</p> <p>Added DTR and RING</p> <p>Removed B14</p> <p>Update ME310G1-WW inhibit area recommendation</p> <p>Extended Voltage Range lower limit change</p>
2	2019-08-13	<p>Added ME310G1-WW</p> <p>Update of Temperature range table</p> <p>N16 pin update (ON_OFF*/WAKE*)</p> <p>ON/OFF procedure updated</p>
1	2019-06-13	<p>Band list update, pinout update</p> <p>Added SIMIN, USB_VBUS, CTANK, PWRMON, ROM_BOOT pins description</p> <p>Added power on procedure</p>
0	2019-03-11	First issue

From Mod.0818 rev.4

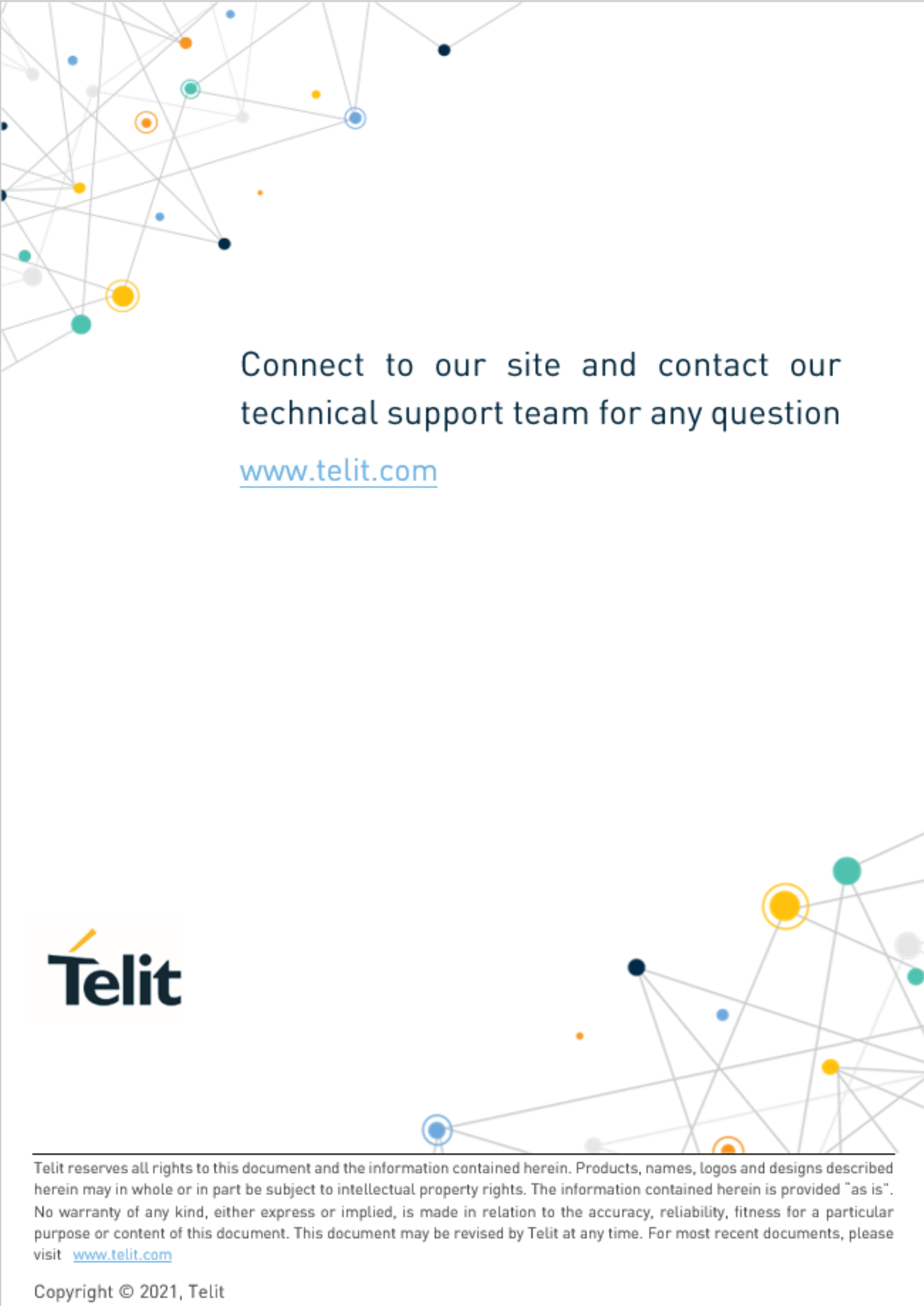
A network diagram consisting of various colored nodes (blue, orange, yellow, green, black, grey) connected by thin grey lines, forming a complex web. The nodes are scattered across the page, with a higher concentration in the top-left and bottom-right corners.

Connect to our site and contact our
technical support team for any question

www.telit.com

The Telit logo features a stylized orange and yellow mark above the word "Telit" in a bold, dark blue sans-serif font.

Telit reserves all rights to this document and the information contained herein. Products, names, logos and designs described herein may in whole or in part be subject to intellectual property rights. The information contained herein is provided "as is". No warranty of any kind, either express or implied, is made in relation to the accuracy, reliability, fitness for a particular purpose or content of this document. This document may be revised by Telit at any time. For most recent documents, please visit www.telit.com

Copyright © 2021, Telit