

FCC Test Report (PART 22)

Report No.: RF180321E03M

FCC ID: R17LN960A16

Test Model: LN960A16

Received Date: Apr. 08, 2019

Test Date: Apr. 08 to May 05, 2019

Issued Date: May 27, 2019

Applicant: Telit Communication S.p.a

Address: Viale Stazione di Prosecco 5/b, Trieste, 34010, Italy

Issued By: Bureau Veritas Consumer Products Services (H.K.) Ltd., Taoyuan Branch
Hsin Chu Laboratory

Lab Address: E-2, No.1, Li Hsin 1st Road, Hsinchu Science Park, Hsinchu City 300,
Taiwan R.O.C.

Test Location: E-2, No.1, Li Hsin 1st Road, Hsinchu Science Park, Hsinchu City 300,
Taiwan R.O.C.

**FCC Registration /
Designation Number:** 723255 / TW2022



This report is for your exclusive use. Any copying or replication of this report to or for any other person or entity, or use of our name or trademark, is permitted only with our prior written permission. This report sets forth our findings solely with respect to the test samples identified herein. The results set forth in this report are not indicative or representative of the quality or characteristics of the lot from which a test sample was taken or any similar or identical product unless specifically and expressly noted. Our report includes all of the tests requested by you and the results thereof based upon the information that you provided to us. You have 60 days from date of issuance of this report to notify us of any material error or omission caused by our negligence, provided, however, that such notice shall be in writing and shall specifically address the issue you wish to raise. A failure to raise such issue within the prescribed time shall constitute your unqualified acceptance of the completeness of this report, the tests conducted and the correctness of the report contents. Unless specific mention, the uncertainty of measurement has been explicitly taken into account to declare the compliance or non-compliance to the specification. The report must not be used by the client to claim product certification, approval, or endorsement by TAF or any government agencies.

Table of Contents

Release Control Record	4
1 Certificate of Conformity	5
2 Summary of Test Results	6
2.1 Measurement Uncertainty	6
2.2 Test Site and Instruments	7
3 General Information	11
3.1 General Description of EUT	11
3.2 Configuration of System under Test	14
3.2.1 Description of Support Units	15
3.3 Test Mode Applicability and Tested Channel Detail	16
3.4 EUT Operating Conditions	20
3.5 General Description of Applied Standards	21
4 Test Types and Results	22
4.1 Output Power Measurement	22
4.1.1 Limits of Output Power Measurement	22
4.1.2 Test Procedures	22
4.1.3 Test Setup	22
4.1.4 Test Results	23
4.2 Modulation characteristics Measurement	36
4.2.1 Limits of Modulation characteristics	36
4.2.2 Test Procedure	36
4.2.3 Test Setup	36
4.2.4 Test Results	37
4.3 Frequency Stability Measurement	40
4.3.1 Limits of Frequency Stability Measurement	40
4.3.2 Test Procedure	40
4.3.3 Test Setup	40
4.3.4 Test Results	41
4.4 Occupied Bandwidth Measurement	45
4.4.1 Test Procedure	45
4.4.2 Test Setup	45
4.4.3 Test Result (-26dB Bandwidth)	46
4.4.4 Test Result (Occupied Bandwidth)	51
4.5 Band Edge Measurement	56
4.5.1 Limits of Band Edge Measurement	56
4.5.2 Test Setup	56
4.5.3 Test Procedures	56
4.5.4 Test Results	57
4.6 Peak to Average Ratio	68
4.6.1 Limits of Peak to Average Ratio Measurement	68
4.6.2 Test Setup	68
4.6.3 Test Procedures	68
4.6.4 Test Results	69
4.7 Conducted Spurious Emissions	74
4.7.1 Limits of Conducted Spurious Emissions Measurement	74
4.7.2 Test Setup	74
4.7.3 Test Procedure	74
4.7.4 Test Results	75
4.8 Radiated Emission Measurement	86
4.8.1 Limits of Radiated Emission Measurement	86
4.8.2 Test Procedure	86
4.8.3 Deviation from Test Standard	86
4.8.4 Test Setup	87

4.8.5 Test Results	88
5 Pictures of Test Arrangements.....	150
Appendix – Information of the Testing Laboratories	151

Release Control Record

Issue No.	Description	Date Issued
RF180321E03M	Original release.	May 27, 2019

1 Certificate of Conformity

Product: LTE M.2 Module

Brand: Telit

Test Model: LN960A16

Sample Status: ENGINEERING SAMPLE

Applicant: Telit Communication S.p.a

Test Date: Apr. 08 to May 05, 2019

Standards: FCC Part 22, Subpart H

The above equipment has been tested by **Bureau Veritas Consumer Products Services (H.K.) Ltd., Taoyuan Branch**, and found compliance with the requirement of the above standards. The test record, data evaluation & Equipment Under Test (EUT) configurations represented herein are true and accurate accounts of the measurements of the sample's EMC characteristics under the conditions specified in this report.

Prepared by :  _____, **Date:** _____ May 27, 2019
Claire Kuan / Specialist

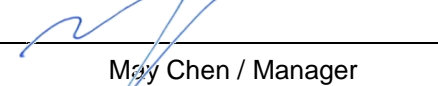
Approved by :  _____, **Date:** _____ May 27, 2019
May Chen / Manager

2 Summary of Test Results

Applied Standard: FCC Part 22 & Part 2			
FCC Clause	Test Item	Result	Remarks
2.1046 22.913 (a)	Effective radiated power	PASS	Meet the requirement of limit.
---	Peak to Average Ratio	PASS	Meet the requirement of limit.
2.1047	Modulation characteristics	PASS	Meet the requirement
2.1055 22.355	Frequency Stability	PASS	Meet the requirement of limit.
2.1049	Occupied Bandwidth	PASS	Meet the requirement of limit.
22.917	Band Edge Measurements	PASS	Meet the requirement of limit.
2.1051 22.917	Conducted Spurious Emissions	PASS	Meet the requirement of limit.
2.1053 22.917	Radiated Spurious Emissions	PASS	Meet the requirement of limit. Minimum passing margin is -33.05dB at 3376MHz.

Note: Determining compliance based on the results of the compliance measurement, not taking into account measurement instrumentation uncertainty.

2.1 Measurement Uncertainty

Where relevant, the following measurement uncertainty levels have been estimated for tests performed on the EUT as specified in CISPR 16-4-2:

Measurement	Frequency	Expanded Uncertainty (k=2) (\pm)
Radiated Emissions up to 1 GHz	30MHz ~ 1GHz	4.8 dB
Radiated Emissions above 1 GHz	1GHz ~ 6GHz	5.0 dB
	6GHz ~ 18GHz	5.0 dB
	18GHz ~ 40GHz	5.3 dB

2.2 Test Site and Instruments

For WCDMA_B5 radiated spurious emissions above 1GHz test:

DESCRIPTION & MANUFACTURER	MODEL NO.	SERIAL NO.	CALIBRATED DATE	CALIBRATED UNTIL
Test Receiver ESR7 R&S	ESR7	102026	Apr. 24, 2019	Apr. 23, 2020
Spectrum Analyzer Keysight	N9030B	MY57141948	June 01, 2018	May 31, 2019
Horn_Antenna SCHWARZBECK	BBHA 9120D	9120D-1819	Nov. 25, 2018	Nov. 24, 2019
Pre-Amplifier EMCI	EMC12630SE	980509	May 03, 2019	May 02, 2020
RF Cable EMCI	EMC104-SM-SM-1500	180503	May 03, 2019	May 02, 2020
RF Cable EMCI	EMC104-SM-SM-2000	180501	May 03, 2019	May 02, 2020
RF Cable EMCI	EMC104-SM-SM-6000	180505	May 03, 2019	May 02, 2020
Pre-Amplifier EMCI	EMC184045SE	980387	Jan. 28, 2019	Jan. 27, 2020
Horn_Antenna SCHWARZBECK	BBHA 9170	BBHA9170519	Nov. 25, 2018	Nov. 24, 2019
RF Cable	EMC102-KM-KM-1200	160924	Jan. 28, 2019	Jan. 27, 2020
RF Cable	EMC102-KM-KM-1200	160925	Jan. 28, 2019	Jan. 27, 2020
Software	ADT_Radiated_V8.7.08	NA	NA	NA
Boresight Antenna Tower & Turn Table Max-Full	MF-7802BS	MF780208530	NA	NA

Note:

1. The calibration interval of the above test instruments is 12 months and the calibrations are traceable to NML/ROC and NIST/USA.
2. The test was performed in 966 Chamber No. 5.
3. Tested Date: May 05, 2019

For LTE CA_5C (5MHz+10MHz) radiated spurious emissions test:

DESCRIPTION & MANUFACTURER	MODEL NO.	SERIAL NO.	CALIBRATED DATE	CALIBRATED UNTIL
Test Receiver ESR7 R&S	ESR7	102026	Apr. 24, 2019	Apr. 23, 2020
Spectrum Analyzer Keysight	N9030B	MY57141948	June 01, 2018	May 31, 2019
Pre-Amplifier EMCI	EMC001340	980142	Jan. 25, 2019	Jan. 24, 2020
Loop Antenna Electro-Metrics	EM-6879	269	Sep. 07, 2018	Sep. 06, 2019
RF Cable	NA	LOOPCAB-001	Jan. 14, 2019	Jan. 13, 2020
RF Cable	NA	LOOPCAB-002	Jan. 14, 2019	Jan. 13, 2020
Pre-Amplifier EMCI	EMC330N	980538	May 07, 2018	May 06, 2019
Trilog Broadband Antenna SCHWARZBECK	VULB9168	9168-0842	Nov. 21, 2018	Nov. 20, 2019
RF Cable	8D	966-5-1	May 07, 2018	May 06, 2019
RF Cable	8D	966-5-2	May 07, 2018	May 06, 2019
RF Cable	8D	966-5-3	May 07, 2018	May 06, 2019
Fixed attenuator Mini-Circuits	UNAT-5+	PAD-ATT5-02	Jan. 28, 2019	Jan. 27, 2020
Horn_Antenna SCHWARZBECK	BBHA 9120D	9120D-1819	Nov. 25, 2018	Nov. 24, 2019
Pre-Amplifier EMCI	EMC12630SE	980509	May 07, 2018	May 06, 2019
RF Cable EMCI	EMC104-SM-SM-1500	180503	May 07, 2018	May 06, 2019
RF Cable EMCI	EMC104-SM-SM-2000	180501	May 07, 2018	May 06, 2019
RF Cable EMCI	EMC104-SM-SM-6000	180505	May 07, 2018	May 06, 2019
Pre-Amplifier EMCI	EMC184045SE	980387	Jan. 28, 2019	Jan. 27, 2020
Horn_Antenna SCHWARZBECK	BBHA 9170	BBHA9170519	Nov. 25, 2018	Nov. 24, 2019
RF Cable	EMC102-KM-KM-1200	160924	Jan. 28, 2019	Jan. 27, 2020
RF Cable	EMC102-KM-KM-1200	160925	Jan. 28, 2019	Jan. 27, 2020
Software	ADT_Radiated_V8.7.08	NA	NA	NA
Boresight Antenna Tower & Turn Table Max-Full	MF-7802BS	MF780208530	NA	NA

Note:

1. The calibration interval of the above test instruments is 12 months and the calibrations are traceable to NML/ROC and NIST/USA.
2. The test was performed in 966 Chamber No. 5.
3. Loop antenna was used for all emissions below 30 MHz.
4. Tested Date: Apr. 26, 2019

For other radiated spurious emissions test:

DESCRIPTION & MANUFACTURER	MODEL NO.	SERIAL NO.	CALIBRATED DATE	CALIBRATED UNTIL
Test Receiver ESR7 R&S	ESR7	102026	Apr. 18, 2018	Apr. 17, 2019
Spectrum Analyzer Keysight	N9030B	MY57141948	June 01, 2018	May 31, 2019
Pre-Amplifier EMCI	EMC001340	980142	Jan. 25, 2019	Jan. 24, 2020
Loop Antenna Electro-Metrics	EM-6879	269	Sep. 07, 2018	Sep. 06, 2019
RF Cable	NA	LOOPCAB-001	Jan. 14, 2019	Jan. 13, 2020
RF Cable	NA	LOOPCAB-002	Jan. 14, 2019	Jan. 13, 2020
Pre-Amplifier EMCI	EMC330N	980538	May 07, 2018	May 06, 2019
Trilog Broadband Antenna SCHWARZBECK	VULB9168	9168-0842	Nov. 21, 2018	Nov. 20, 2019
RF Cable	8D	966-5-1	May 07, 2018	May 06, 2019
RF Cable	8D	966-5-2	May 07, 2018	May 06, 2019
RF Cable	8D	966-5-3	May 07, 2018	May 06, 2019
Fixed attenuator Mini-Circuits	UNAT-5+	PAD-ATT5-02	Jan. 28, 2019	Jan. 27, 2020
Horn_Antenna SCHWARZBECK	BBHA 9120D	9120D-1819	Nov. 25, 2018	Nov. 24, 2019
Pre-Amplifier EMCI	EMC12630SE	980509	May 07, 2018	May 06, 2019
RF Cable EMCI	EMC104-SM-SM-1500	180503	May 07, 2018	May 06, 2019
RF Cable EMCI	EMC104-SM-SM-2000	180501	May 07, 2018	May 06, 2019
RF Cable EMCI	EMC104-SM-SM-6000	180505	May 07, 2018	May 06, 2019
Pre-Amplifier EMCI	EMC184045SE	980387	Jan. 28, 2019	Jan. 27, 2020
Horn_Antenna SCHWARZBECK	BBHA 9170	BBHA9170519	Nov. 25, 2018	Nov. 24, 2019
RF Cable	EMC102-KM-KM-1200	160924	Jan. 28, 2019	Jan. 27, 2020
RF Cable	EMC102-KM-KM-1200	160925	Jan. 28, 2019	Jan. 27, 2020
Software	ADT_Radiated_V8.7.08	NA	NA	NA
Boresight Antenna Tower & Turn Table Max-Full	MF-7802BS	MF780208530	NA	NA

Note:

1. The calibration interval of the above test instruments is 12 months and the calibrations are traceable to NML/ROC and NIST/USA.
2. The test was performed in 966 Chamber No. 5.
3. Loop antenna was used for all emissions below 30 MHz.
4. Tested Date: Apr. 17, 2019

For other test items:

DESCRIPTION & MANUFACTURER	MODEL NO.	SERIAL NO.	CALIBRATED DATE	CALIBRATED UNTIL
Spectrum Analyzer R&S	FSV40	100964	June 20, 2018	June 19, 2019
Spectrum Analyzer Agilent	E4446A	MY48250254	Nov. 14, 2018	Nov. 13, 2019
Power meter Anritsu	ML2495A	1014008	May 09, 2018	May 08, 2019
Power sensor Anritsu	MA2411B	0917122	May 09, 2018	May 08, 2019
Fixed Attenuator Mini-Circuits	MDCS18N-10	MDCS18N-10-01	Apr. 16, 2018	Apr. 15, 2019
AC Power Source Extech Electronics	6205	1440452	NA	NA
DC Power Supply Topward	6603D	795558	NA	NA
Temperature & Humidity Chamber Giant Force	GTH-150-40-SP-AR	MAA0812-008	Jan. 09, 2019	Jan. 08, 2020
True RMS Clamp Meter FLUKE	325	31130711WS	May 22, 2018	May 21, 2019
ESG Vector signal generator Agilent	E4438C	MY45094468/005 506 602 UK6 UNJ	Nov. 19, 2018	Nov. 18, 2019
Mech Switch Absorptive Mini-Circuits	MSP4TA-18+	0140	Feb. 11, 2019	Feb. 10, 2020
FXD ATTEN Mini-Circuits	BW-S3W2+	MN71981	Feb. 11, 2019	Feb. 10, 2020
Software	ADT_RF Test Software V6.6.5.4	NA	NA	NA

- NOTE:**
1. The test was performed in Oven room 2.
 2. The calibration interval of the above test instruments is 12 months and the calibrations are traceable to NML/ROC and NIST/USA.
 3. Tested Date: Apr. 08, 2019

3 General Information

3.1 General Description of EUT

Product	LTE M.2 Module	
Brand	Telit	
Test Model	LN960A16	
Status of EUT	ENGINEERING SAMPLE	
Power Supply Rating	DC 3.3V from host equipment	
Modulation Type	WCDMA, HSDPA, HSUPA	BPSK
	LTE Band 5	QPSK, 16QAM, 64QAM
	LTE Band 26	QPSK, 16QAM, 64QAM
Operating Frequency	WCDMA, HSDPA, HSUPA	826.4MHz ~846.6MHz
	LTE Band 5	824.7MHz ~ 848.3MHz
	LTE Band 26	824.7MHz ~ 848.3MHz
Max. ERP Power	WCDMA Band 5	24.82dBm
	LTE Band 5 (Channel Bandwidth 1.4MHz)	24.40dBm
	LTE Band 5 (Channel Bandwidth 3MHz)	24.36dBm
	LTE Band 5 (Channel Bandwidth 5MHz)	24.33dBm
	LTE Band 5 (Channel Bandwidth 10MHz)	24.29dBm
	LTE Band 5 (Channel Bandwidth 5+10MHz)	24.15dBm
	LTE Band 5 (Channel Bandwidth 10+10MHz)	21.33dBm
	LTE Band 26 (Channel Bandwidth 1.4MHz)	24.61dBm
	LTE Band 26 (Channel Bandwidth 3MHz)	24.76dBm
	LTE Band 26 (Channel Bandwidth 5MHz)	24.50dBm
	LTE Band 26 (Channel Bandwidth 10MHz)	24.57dBm
	LTE Band 26 (Channel Bandwidth 15MHz)	24.69dBm

Emission Designator	WCDMA Band 5	4M13F9W
	LTE Band 5 (Channel Bandwidth 1.4MHz)	QPSK: 1M08G7D 16QAM: 1M09D7W 64QAM: 1M09D7W
	LTE Band 5 (Channel Bandwidth 3MHz)	QPSK: 2M70G7D 16QAM: 2M68D7W 64QAM: 2M70D7W
	LTE Band 5 (Channel Bandwidth 5MHz)	QPSK: 4M50G7D 16QAM: 4M51D7W 64QAM: 4M50D7W
	LTE Band 5 (Channel Bandwidth 10MHz)	QPSK: 9M00G7D 16QAM: 9M02D7W 64QAM: 9M02D7W
	LTE Band 5 (Channel Bandwidth 5+10MHz)	QPSK: 14M0G7D
	LTE Band 5 (Channel Bandwidth 10+10MHz)	QPSK: 18M9G7D
	LTE Band 26 (Channel Bandwidth 1.4MHz)	QPSK: 1M09G7D 16QAM: 1M09D7W 64QAM: 1M09D7W
	LTE Band 26 (Channel Bandwidth 3MHz)	QPSK: 2M70G7D 16QAM: 2M68D7W 64QAM: 2M70D7W
	LTE Band 26 (Channel Bandwidth 5MHz)	QPSK: 4M51G7D 16QAM: 4M51D7W 64QAM: 4M51D7W
	LTE Band 26 (Channel Bandwidth 10MHz)	QPSK: 9M00G7D 16QAM: 9M00D7W 64QAM: 9M00D7W
	LTE Band 26 (Channel Bandwidth 15MHz)	QPSK: 13M5G7D 16QAM: 13M5D7W 64QAM: 13M5D7W
Antenna Type	Refer to Note	
Antenna Connector	Refer to Note	
Accessory Device	NA	
Data Cable Supplied	NA	

Note:

1. The antennas provided to the EUT, please refer to the following table:

Antenna No.	Antenna Net Gain(dBi)	Frequency range (MHz)	Antenna Type	Connector Type	Cable Length
1	Please refer to below table	699~803	PIFA	i-pex(MHF)	100mm
2	Please refer to below table	791~960 1447.9~1606	PIFA	i-pex(MHF)	100mm
3	Please refer to below table	1710~2170 2500~2690	PIFA	i-pex(MHF)	100mm
4	Please refer to below table	5110~5925 (for LAA RX)	PIFA	i-pex(MHF)	100mm
5	Please refer to below table	2305~2315	Dipole	i-pex(MHF)	80mm

Antenna gain list

Antenna No.	Band	Freq. Range (MHz)	Gain (dBi)
3	WCDMA II (B2)	1850~1910	4.92
3	WCDMA IV (B4)	1710~1755	5.99
2	WCDMA V (B5)	824~849	2.68
3	LTE Band (2)	1850~1910	4.92
3	LTE Band (4)	1710~1755	5.99
2	LTE Band (5)	824~849	2.68
3	LTE Band (7)	2500~2570	5.2
1	LTE Band (12)	698~716	4.17
1	LTE Band (13)	777~787	3.05
1	LTE Band (14)	788~798	2.87
1	LTE Band (17)	704~716	4.17
3	LTE Band (25)	1850~1915	4.92
2	LTE Band (26)	814~849	2.92
5	LTE Band (30)	2305~2315	3.02
3	LTE Band (38)	2570~2620	4.82
3	LTE Band (41)	2496~2690	5.38
3	LTE Band (66)	1710~1780	5.99

2. This device is UE LTE module that can support carrier aggregation (two carrier) uplink Intra-Band contiguous, specification following as below:

Uplink CA Configurations	Component carriers in order of increasing carrier frequency		Maximum Aggregated Bandwidth [MHz]	Bandwidth Combination Set
	Channel bandwidths for carrier-1 [MHz]	Channel bandwidths for carrier-2 [MHz]		
CA_5B	5,10	10	20	0
	10	5		

3. The above EUT information is declared by manufacturer and for more detailed features description, please refer to the manufacturer's specifications or User's Manual.

3.2 Configuration of System under Test

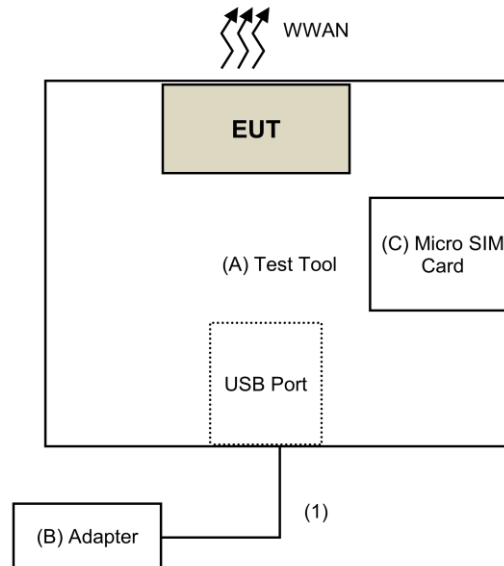

Remote Site



3.2.1 Description of Support Units

The EUT has been tested as an independent unit together with other necessary accessories or support units. The following support units or accessories were used to form a representative test configuration during the tests.

ID	Product	Brand	Model No.	Serial No.	FCC ID	Remarks
A.	Test Tool	Foxconn	LN960A16	NA	NA	Supplied by client
B.	Adapter	ASUS	EXA1205UA	NA	NA	Provided by Lab
C.	SIM Card	NA	NA	NA	NA	Provided by Lab
D.	Simulator	Keysight	E7515A	MY56030229	NA	Provided by Lab

Note:

1. All power cords of the above support units are non-shielded (1.8m).

ID	Descriptions	Qty.	Length (m)	Shielding (Yes/No)	Cores (Qty.)	Remarks
1.	USB Cable	1	1	Yes	0	Provided by Lab

3.3 Test Mode Applicability and Tested Channel Detail

Pre-Scan has been conducted to determine the worst-case mode from all possible combinations between available modulations, data rates, XYZ axis and antenna ports

The worst case was found when positioned on X-plane. Following channel(s) was (were) selected for the final test as listed below:

WCDMA V MODE

Test Item	Available Channel	Tested Channel	Mode
ERP	4132 to 4233	4132, 4182, 4233	WCDMA
Frequency Stability	4132 to 4233	4182	WCDMA
Occupied Bandwidth	4132 to 4233	4132, 4182, 4233	WCDMA
Peak to Average Ratio	4132 to 4233	4132, 4182, 4233	WCDMA
Band Edge	4132 to 4233	4132, 4233	WCDMA
Conducted Emission	4132 to 4233	4132, 4182, 4233	WCDMA
Radiated Emission Below 1GHz	4132 to 4233	4132, 4182, 4233	WCDMA
Radiated Emission Above 1GHz	4132 to 4233	4132, 4182, 4233	WCDMA

LTE Band 5

TEST ITEM	AVAILABLE CHANNEL	TESTED CHANNEL	CHANNEL BANDWIDTH	MODULATION	MODE
ERP	20407 to 20643	20407, 20525, 20643	1.4MHz	QPSK/16QAM/64QAM	1RB / 0 RB offset
	20415 to 20635	20415, 20525, 20635	3MHz	QPSK/16QAM/64QAM	1RB / 0 RB offset
	20425 to 20625	20425, 20525, 20625	5MHz	QPSK/16QAM/64QAM	1RB / 0 RB offset
	20450 to 20600	20450, 20525, 20600	10MHz	QPSK/16QAM/64QAM	1RB / 0 RB offset
Frequency Stability	20407 to 20643	20525	1.4MHz	QPSK	-
	20415 to 20635	20525	3MHz	QPSK	-
	20425 to 20625	20525	5MHz	QPSK	-
	20450 to 20600	20525	10MHz	QPSK	-
Occupied Bandwidth	20407 to 20643	20407, 20525, 20643	1.4MHz	QPSK/16QAM/64QAM	Full RB
	20415 to 20635	20415, 20525, 20635	3MHz	QPSK/16QAM/64QAM	Full RB
	20425 to 20625	20425, 20525, 20625	5MHz	QPSK/16QAM/64QAM	Full RB
	20450 to 20600	20450, 20525, 20600	10MHz	QPSK/16QAM/64QAM	Full RB
Peak to Average Ratio	20407 to 20643	20407, 20525, 20643	1.4MHz	QPSK/16QAM/64QAM	Full RB
	20415 to 20635	20415, 20525, 20635	3MHz	QPSK/16QAM/64QAM	Full RB
	20425 to 20625	20425, 20525, 20625	5MHz	QPSK/16QAM/64QAM	Full RB
	20450 to 20600	20450, 20525, 20600	10MHz	QPSK/16QAM/64QAM	Full RB
Band Edge	20407 to 20643	20407	1.4MHz	QPSK	1 RB / 0 RB Offset
		20643			1 RB / 5 RB Offset
		20407, 20643			6 RB / 0 RB Offset
	20415 to 20635	20415	3MHz	QPSK	1 RB / 0 RB Offset
		20635			1 RB / 14 RB Offset
		20415, 20635			15 RB / 0 RB Offset
	20425 to 20625	20425	5MHz	QPSK	1 RB / 0 RB Offset
		20625			1 RB / 24 RB Offset
		20425, 20625			25 RB / 0 RB Offset
	20450 to 20600	20450	10MHz	QPSK	1 RB / 0 RB Offset
		20600			1 RB / 49 RB Offset
		20450, 20600			50 RB / 0 RB Offset
Conducted Emission	20407 to 20643	20407, 20525, 20643	1.4MHz	QPSK	1RB / 0 RB offset
	20415 to 20635	20415, 20525, 20635	3MHz	QPSK	1RB / 0 RB offset
	20425 to 20625	20425, 20525, 20625	5MHz	QPSK	1RB / 0 RB offset
	20450 to 20600	20450, 20525, 20600	10MHz	QPSK	1RB / 0 RB offset
Radiated Emission	20407 to 20643	20407, 20525, 20643	1.4MHz	QPSK	1RB / 0 RB offset
	20415 to 20635	20415, 20525, 20635	3MHz	QPSK	1RB / 0 RB offset
	20425 to 20625	20425, 20525, 20625	5MHz	QPSK	1RB / 0 RB offset
	20450 to 20600	20450, 20525, 20600	10MHz	QPSK	1RB / 0 RB offset

LTE CA_5C

TEST ITEM	MODULATION	PCC			SCC		
		CHANNEL BANDWIDTH	TESTED CHANNEL	MODE	CHANNEL BANDWIDTH	TESTED CHANNEL	MODE
ERP	QPSK	5MHz	20528	1RB / 0 RB offset	10MHz	20600	0RB / 0 RB offset
Frequency Stability	QPSK	5MHz	20528	-	10MHz	20600	-
Occupied Bandwidth	QPSK	5MHz	20528	25RB / 0 RB offset	10MHz	20600	50RB / 0 RB offset
Peak to Average Ratio	QPSK	5MHz	20528	25RB / 0 RB offset	10MHz	20600	50RB / 0 RB offset
Band Edge	QPSK	5MHz	20425	25RB / 0 RB offset	10MHz	20497	50RB / 0 RB offset
				1RB / 0 RB offset			0RB / 0 RB offset
			20528	25RB / 0 RB offset		20600	50RB / 0 RB offset
				0RB / 0 RB offset			1RB / 99 RB offset
Conducted Emission	QPSK	5MHz	20528	1RB / 0 RB offset	10MHz	20600	0RB / 0 RB offset
Radiated Emission	QPSK	5MHz	20528	1RB / 0 RB offset	10MHz	20600	0RB / 0 RB offset

Note: This product supports multiple carriers in intra-band contiguous spectrum operation, therefore test mode and test configurations follow KDB inquiry (more detail information refer "Operation Description.pdf").

LTE Band 26

TEST ITEM	AVAILABLE CHANNEL	TESTED CHANNEL	CHANNEL BANDWIDTH	MODULATION	MODE
ERP	26797 to 27033	26797, 26915, 27033	1.4MHz	QPSK/16QAM/64QAM	1RB / 0 RB offset
	26805 to 27025	26805, 26915, 27025	3MHz	QPSK/16QAM/64QAM	1RB / 0 RB offset
	26815 to 27015	26815, 26915, 27015	5MHz	QPSK/16QAM/64QAM	1RB / 0 RB offset
	26840 to 26990	26840, 26915, 26990	10MHz	QPSK/16QAM/64QAM	1RB / 0 RB offset
	26865 to 26965	26865, 26915, 26965	15MHz	QPSK/16QAM/64QAM	1RB / 0 RB offset
Frequency Stability	26797 to 27033	26915	1.4MHz	QPSK	-
	26805 to 27025	26915	3MHz	QPSK	-
	26815 to 27015	26915	5MHz	QPSK	-
	26840 to 26990	26915	10MHz	QPSK	-
	26865 to 26965	26915	15MHz	QPSK	-
Occupied Bandwidth	26797 to 27033	26797, 26915, 27033	1.4MHz	QPSK/16QAM/64QAM	Full RB
	26805 to 27025	26805, 26915, 27025	3MHz	QPSK/16QAM/64QAM	Full RB
	26815 to 27015	26815, 26915, 27015	5MHz	QPSK/16QAM/64QAM	Full RB
	26840 to 26990	26840, 26915, 26990	10MHz	QPSK/16QAM/64QAM	Full RB
	26865 to 26965	26865, 26915, 26965	15MHz	QPSK/16QAM/64QAM	Full RB
Peak to Average Ratio	26797 to 27033	26797, 26915, 27033	1.4MHz	QPSK/16QAM/64QAM	Full RB
	26805 to 27025	26805, 26915, 27025	3MHz	QPSK/16QAM/64QAM	Full RB
	26815 to 27015	26815, 26915, 27015	5MHz	QPSK/16QAM/64QAM	Full RB
	26840 to 26990	26840, 26915, 26990	10MHz	QPSK/16QAM/64QAM	Full RB
	26865 to 26965	26865, 26915, 26965	15MHz	QPSK/16QAM/64QAM	Full RB
Band Edge	26797 to 27033	26797	1.4MHz	QPSK	1 RB / 0 RB Offset
		27033			1 RB / 5 RB Offset
		26797, 27033			6 RB / 0 RB Offset
	26805 to 27025	26805	3MHz	QPSK	1 RB / 0 RB Offset
		27025			1 RB / 14 RB Offset
		26805, 27025			15 RB / 0 RB Offset
	26815 to 27015	26815	5MHz	QPSK	1 RB / 0 RB Offset
		27015			1 RB / 24 RB Offset
		26815, 27015			25 RB / 0 RB Offset
	26840 to 26990	26840	10MHz	QPSK	1 RB / 0 RB Offset
		26990			1 RB / 49 RB Offset
		26840, 26990			50 RB / 0 RB Offset
	26865 to 26965	26865	15MHz	QPSK	1 RB / 0 RB Offset
		26965			1 RB / 74 RB Offset
		26865, 26965			75 RB / 0 RB Offset
Conducted Emission	26797 to 27033	26797, 26915, 27033	1.4MHz	QPSK	1RB / 0 RB offset
	26805 to 27025	26805, 26915, 27025	3MHz	QPSK	1RB / 0 RB offset
	26815 to 27015	26815, 26915, 27015	5MHz	QPSK	1RB / 0 RB offset
	26840 to 26990	26840, 26915, 26990	10MHz	QPSK	1RB / 0 RB offset
	26865 to 26965	26865, 26915, 26965	15MHz	QPSK	1RB / 0 RB offset
Radiated Emission	26797 to 27033	26797, 26915, 27033	1.4MHz	QPSK	1RB / 0 RB offset
	26805 to 27025	26805, 26915, 27025	3MHz	QPSK	1RB / 0 RB offset
	26815 to 27015	26815, 26915, 27015	5MHz	QPSK	1RB / 0 RB offset
	26840 to 26990	26840, 26915, 26990	10MHz	QPSK	1RB / 0 RB offset
	26865 to 26965	26865, 26915, 26965	15MHz	QPSK	1RB / 0 RB offset

NOTE:

All supported modulation types were evaluated. The Worst case of QPSK was selected. Therefore, the Band Edge, Frequency Stability, Condcudeted Emission and Radiated Emission were presented under QPSK mode only.

Test Condition:

Test Item	Environmental Conditions	Input Power (System)	Tested By
ERP	25deg. C, 63%RH	120Vac, 60Hz	Jyunchun Lin
Frequency Stability	25deg. C, 63%RH	120Vac, 60Hz	Jyunchun Lin
Occupied Bandwidth	25deg. C, 63%RH	120Vac, 60Hz	Jyunchun Lin
Band Edge	25deg. C, 63%RH	120Vac, 60Hz	Jyunchun Lin
Peak to Average Ratio	25deg. C, 63%RH	120Vac, 60Hz	Jyunchun Lin
Conducuted Emission	25deg. C, 63%RH	120Vac, 60Hz	Jyunchun Lin
Radiated Emission Below 1GHz	25deg. C, 75%RH	120Vac, 60Hz	James Chan
Radiated Emission Above 1GHz	25deg. C, 75%RH	120Vac, 60Hz	James Chan

3.4 EUT Operating Conditions

The communication simulator station system controlled a EUT to export maximum output power under transmission mode and specific channel frequency

3.5 General Description of Applied Standards

The EUT is a RF Product. According to the specifications of the manufacturer, it must comply with the requirements of the following standards:

FCC 47 CFR Part 2

FCC 47 CFR Part 22, Subpart H

KDB 971168 D01 Power Meas License Digital Systems v03r01

ANSI/TIA/EIA-603-E 2016

ANSI 63.26-2015

NOTE: All test items have been performed and recorded as per the above standards.

4 Test Types and Results

4.1 Output Power Measurement

4.1.1 Limits of Output Power Measurement

Mobile / Portable station are limited to 7 watts e.r.p.

4.1.2 Test Procedures

Conducted Power Measurement:

The EUT was set up for the maximum power with WCDMA / LTE link data modulation and link up with simulator. Set the EUT to transmit under low, middle and high channel and difference RB size/ RB offset for difference bandwidth record the power level shown on power meter.

EIRP / ERP Measurement:

- EIRP = Conducted Output power level + Antenna gain.
- ERP power can be calculated form EIRP power by subtracting the gain of dipole, ERP power = EIPR power - 2.15dBi.
- ERP = Conducted Output power level + Antenna gain (dBi) - Isotropically Factor (2.15dB).

4.1.3 Test Setup

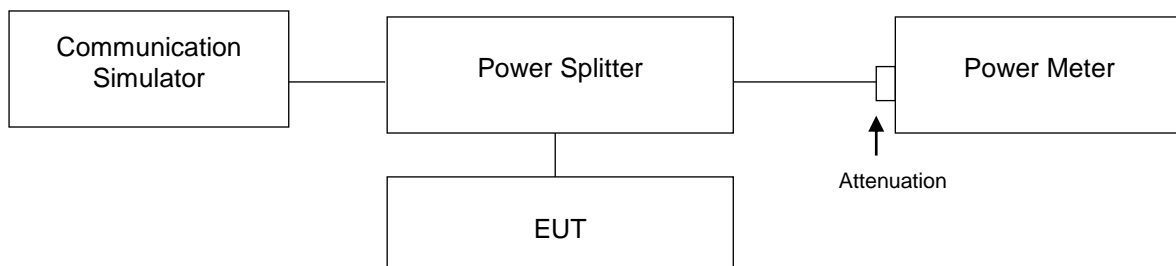

For the actual test configuration, please refer to the attached file (Test Setup Photo).

4.1.4 Test Results

CONDUCTED OUTPUT POWER (dBm)

WCDMA Band 5

Band	WCDMA V		
Channel	4132	4182	4233
Frequency (MHz)	826.4	836.4	846.6
RMC	24.10	24.04	24.29
HSDPA Subtest-1	24.18	24.01	23.96
HSDPA Subtest-2	23.68	23.25	23.73
HSDPA Subtest-3	23.76	23.36	23.40
HSDPA Subtest-4	23.33	23.21	23.60
HSUPA Subtest-1	23.96	24.05	23.58
HSUPA Subtest-2	23.75	23.96	23.74
HSUPA Subtest-3	23.82	23.69	23.50
HSUPA Subtest-4	23.58	23.49	23.92
HSUPA Subtest-5	23.88	24.18	24.12

LTE Band 5

Band / BW	RB Size	RB Offset	QPSK			3GPP MPR (dB)	16QAM			3GPP MPR (dB)	64QAM			3GPP MPR (dB)
			Low CH	Mid CH	High CH		Low CH	Mid CH	High CH		Low CH	Mid CH	High CH	
			20407	20525	20643		20407	20525	20643		20407	20525	20643	
			824.7	836.5	848.3		824.7	836.5	848.3		824.7	836.5	848.3	
			MHz	MHz	MHz		MHz	MHz	MHz		MHz	MHz	MHz	
5 / 1.4M	1	0	23.29	23.87	23.83	0	22.68	22.33	22.34	1	21.52	21.54	21.35	2
	1	2	23.56	23.83	23.66	0	22.31	22.76	22.21	1	21.35	21.77	21.51	2
	1	5	23.84	23.41	23.63	0	22.48	22.37	22.32	1	21.48	21.75	21.62	2
	3	0	23.53	23.53	23.22	0	22.49	22.44	22.41	1	21.68	21.28	21.19	2
	3	1	23.37	23.73	23.60	0	22.73	22.54	22.53	1	21.28	21.75	21.14	2
	3	3	23.84	23.63	22.21	0	22.43	22.58	22.54	1	21.31	21.88	21.37	2
	6	0	22.84	22.42	22.38	1	21.29	21.48	21.65	2	20.23	20.72	20.04	3

Band / BW	RB Size	RB Offset	QPSK			3GPP MPR (dB)	16QAM			3GPP MPR (dB)	64QAM			3GPP MPR (dB)
			Low CH	Mid CH	High CH		Low CH	Mid CH	High CH		Low CH	Mid CH	High CH	
			20415	20525	20635		20415	20525	20635		20415	20525	20635	
			825.5	836.5	847.5		825.5	836.5	847.5		825.5	836.5	847.5	
			MHz	MHz	MHz		MHz	MHz	MHz		MHz	MHz	MHz	
5 / 3M	1	0	23.43	23.83	23.62	0	22.86	22.40	22.55	1	21.86	21.63	21.55	2
	1	7	23.46	23.75	23.81	0	22.37	22.38	22.86	1	21.33	21.81	21.67	2
	1	14	23.82	23.75	23.36	0	22.62	22.77	22.50	1	21.49	21.73	21.44	2
	8	0	22.91	22.57	22.48	1	21.55	21.58	21.32	2	20.18	20.84	20.40	3
	8	3	22.64	22.65	22.84	1	21.88	21.79	21.47	2	20.29	20.52	20.56	3
	8	7	22.51	22.90	22.46	1	21.96	23.01	21.72	2	20.65	20.61	20.50	3
	15	0	22.53	22.52	22.43	1	21.78	21.57	21.29	2	20.40	20.68	20.61	3

Band / BW	RB Size	RB Offset	QPSK			3GPP MPR (dB)	16QAM			3GPP MPR (dB)	64QAM			3GPP MPR (dB)
			Low CH	Mid CH	High CH		Low CH	Mid CH	High CH		Low CH	Mid CH	High CH	
			20425	20525	20625		20425	20525	20625		20425	20525	20625	
			826.5	836.5	846.5		826.5	836.5	846.5		826.5	836.5	846.5	
			MHz	MHz	MHz		MHz	MHz	MHz		MHz	MHz	MHz	
5 / 5M	1	0	23.80	23.36	23.32	0	22.44	22.57	22.39	1	21.29	21.76	21.21	2
	1	12	23.36	23.50	23.30	0	22.31	22.59	22.36	1	21.27	21.88	21.75	2
	1	24	23.64	23.49	23.61	0	22.34	22.49	22.08	1	21.27	21.74	21.33	2
	12	0	22.80	22.26	22.28	1	21.60	21.63	21.61	2	20.58	20.47	20.37	3
	12	6	22.42	22.77	22.37	1	21.28	21.56	21.72	2	20.67	20.60	20.49	3
	12	13	22.53	22.33	22.33	1	21.33	21.23	21.82	2	20.40	20.51	20.64	3
	25	0	22.49	22.64	22.78	1	21.49	21.18	21.79	2	20.43	20.39	20.58	3

Band / BW	RB Size	RB Offset	QPSK			3GPP MPR (dB)	16QAM			3GPP MPR (dB)	64QAM			3GPP MPR (dB)
			Low CH	Mid CH	High CH		Low CH	Mid CH	High CH		Low CH	Mid CH	High CH	
			20450	20525	20600		20450	20525	20600		20450	20525	20600	
			829	836.5	844		829	836.5	844		829	836.5	844	
			MHz	MHz	MHz		MHz	MHz	MHz		MHz	MHz	MHz	
5 / 10M	1	0	23.51	23.76	23.45	0	22.30	22.56	23.04	1	21.80	21.23	21.79	2
	1	24	23.47	23.51	23.45	0	22.80	22.51	23.00	1	21.81	21.28	21.89	2
	1	49	23.67	23.71	23.47	0	22.50	22.16	23.03	1	21.40	21.41	21.38	2
	25	0	22.79	22.66	22.82	1	21.54	21.87	21.46	2	20.86	20.85	20.71	3
	25	12	22.70	22.81	22.92	1	21.97	21.86	21.65	2	20.51	20.71	20.55	3
	25	25	22.55	22.61	22.72	1	21.39	21.84	21.50	2	20.32	20.78	20.63	3
	50	0	22.68	22.77	22.48	1	21.46	21.97	21.86	2	20.61	20.57	20.21	3

LTE CA_5C (PCC/SCC: 5M+10M)

Intra Band-Contiguous CA															
PCC							SCC							MPR	
Band	BW (MHz)	Modulation	RB Size	RB Offset	UL Channel	UL Frequency (MHz)	Band	BW (MHz)	Modulation	RB Size	RB Offset	UL Channel	UL Frequency (MHz)	MPR Level (dB)	Tx Power with UL-CA Active (dBm) Level (dB)
5	5	QPSK	0	0	20425	826.5	5	10	QPSK	1	49	20497	833.7	0	23.32
			1	0						0	0			0	23.11
			25	0						0	0			0-1	21.91
			25	0						50	0			0-2	20.36
			1	0						1	49			0-8.5	15.11
			1	0						1	0			0-4.5	18.93
			1	24						1	0			0	23.39
			25	0						1	49			0-3.5	16.08
5	5	QPSK	0	0	20478	831.8	5	10	QPSK	1	49	20550	839	0	23.26
			1	0						0	0			0	23.32
			25	0						0	0			0-1	22.42
			25	0						50	0			0-2	20.84
			1	0						1	49			0-8.5	14.77
			1	0						1	0			0-4.5	19.34
			1	24						1	0			0	22.97
			25	0						1	49			0-3.5	18.3
5	5	QPSK	0	0	20528	836.8	5	10	QPSK	1	49	20600	844	0	23.4
			1	0						0	0			0	23.62
			25	0						0	0			0-1	21.73
			25	0						50	0			0-2	20.81
			1	0						1	49			0-8.5	14.48
			1	0						1	0			0-4.5	18.59
			1	24						1	0			0	22.74
			25	0						1	49			0-3.5	18.58

LTE CA_5C (PCC/SCC: 10M+5M)

Intra Band-Contiguous CA															
PCC						SCC						MPR			
Band	BW (MHz)	Modulation	RB Size	RB Offset	UL Channel	UL Frequency (MHz)	Band	BW (MHz)	Modulation	RB Size	RB Offset	UL Channel	UL Frequency (MHz)	MPR Level (dB)	Tx Power with UL-CA Active (dBm) Level (dB)
5	10	QPSK	0	0	20450	829	5	5	QPSK	1	24	20522	836.2	0	23.33
			1	0						0	0			0	23.03
			50	0						0	0			0-1	21.89
			50	0						25	0			0-2	19.97
			1	0						1	24			0-8.5	14.77
			1	0						1	0			0-4.5	18.96
			1	49						1	0			0	23.3
			50	0						1	24			0-3.5	16.16
5	10	QPSK	0	0	20500	834	5	5	QPSK	1	24	20572	841.2	0	22.86
			1	0						0	0			0	23.45
			50	0						0	0			0-1	22.35
			50	0						25	0			0-2	20.39
			1	0						1	24			0-8.5	14.94
			1	0						1	0			0-4.5	18.79
			1	49						1	0			0	23.08
			50	0						1	24			0-3.5	18.6
5	10	QPSK	0	0	20553	839.3	5	5	QPSK	1	24	20625	846.5	0	23.03
			1	0						0	0			0	23.11
			50	0						0	0			0-1	21.39
			50	0						25	0			0-2	20.52
			1	0						1	24			0-8.5	14.54
			1	0						1	0			0-4.5	18.53
			1	49						1	0			0	22.78
			50	0						1	24			0-3.5	18.26

LTE CA_5C (PCC/SCC: 10M+10M)

Intra Band-Contiguous CA															
PCC							SCC							MPR	
Band	BW (MHz)	Modulation	RB Size	RB Offset	UL Channel	UL Frequency (MHz)	Band	BW (MHz)	Modulation	RB Size	RB Offset	UL Channel	UL Frequency (MHz)	MPR Level (dB)	Tx Power with UL-CA Active (dBm) Level (dB)
5	10	QPSK	0	0	20450	829	5	10	QPSK	1	49	20549	838.9	0	23.59
			1	0						0	0			0	23.16
			50	0						0	0			0-1	21.78
			50	0						50	0			0-2	20.43
			1	0						1	49			0-8.5	14.84
			1	0						1	0			0-4.5	18.86
			1	49						1	0			0	23.38
			50	0						1	49			0-3.5	16.26
5	10	QPSK	0	0	20475	831.5	5	10	QPSK	1	49	20574	841.4	0	23.45
			1	0						0	0			0	23.27
			50	0						0	0			0-1	22.09
			50	0						50	0			0-2	20.77
			1	0						1	49			0-8.5	14.6
			1	0						1	0			0-4.5	19.06
			1	49						1	0			0	22.96
			50	0						1	49			0-3.5	18.27
5	10	QPSK	0	0	20501	834.1	5	10	QPSK	1	49	20600	844	0	23.52
			1	0						0	0			0	22.92
			50	0						0	0			0-1	21.97
			50	0						50	0			0-2	20.8
			1	0						1	49			0-8.5	14.66
			1	0						1	0			0-4.5	18.64
			1	49						1	0			0	22.93
			50	0						1	49			0-3.5	18.08

LTE Band 26

Band / BW	RB Size	RB Offset	QPSK			3GPP MPR (dB)	16QAM			3GPP MPR (dB)	64QAM			3GPP MPR (dB)
			Low CH	Mid CH	High CH		Low CH	Mid CH	High CH		Low CH	Mid CH	High CH	
			26797	26915	27033		26797	26915	27033		26797	26915	27033	
			824.7	836.5	848.3		824.7	836.5	848.3		824.7	836.5	848.3	
			MHz	MHz	MHz		MHz	MHz	MHz		MHz	MHz	MHz	
26 / 1.4M	1	0	23.84	23.26	23.45	0	22.75	22.51	22.32	1	21.34	21.58	21.47	2
	1	2	23.79	23.42	23.26	0	22.29	22.76	22.22	1	21.74	21.74	21.67	2
	1	5	23.53	23.53	23.25	0	22.26	22.78	22.41	1	21.50	21.44	21.78	2
	3	0	23.28	23.81	23.75	0	22.76	22.58	22.23	1	21.34	21.24	21.54	2
	3	1	23.61	23.68	23.47	0	22.34	22.33	22.39	1	21.68	21.18	21.34	2
	3	3	23.63	23.32	22.26	0	22.31	22.42	22.64	1	21.54	21.20	21.28	2
	6	0	22.74	22.51	22.41	1	21.47	21.18	21.38	2	20.18	20.61	20.62	3

Band / BW	RB Size	RB Offset	QPSK			3GPP MPR (dB)	16QAM			3GPP MPR (dB)	64QAM			3GPP MPR (dB)
			Low CH	Mid CH	High CH		Low CH	Mid CH	High CH		Low CH	Mid CH	High CH	
			26805	26915	27025		26805	26915	27025		26805	26915	27025	
			825.50	836.50	847.50		825.50	836.50	847.50		825.5	836.5	847.5	
			MHz	MHz	MHz		MHz	MHz	MHz		MHz	MHz	MHz	
26 / 3M	1	0	23.99	23.51	23.53	0	22.41	22.48	22.28	1	21.47	21.37	21.64	2
	1	7	23.76	23.81	23.77	0	22.52	22.53	22.27	1	21.18	21.14	21.63	2
	1	14	23.59	23.79	23.26	0	22.32	22.38	22.35	1	21.47	21.46	21.64	2
	8	0	22.45	22.49	22.64	1	21.40	21.61	21.46	2	20.12	20.52	20.52	3
	8	3	22.61	22.66	22.44	1	21.34	21.50	21.66	2	20.59	20.12	20.31	3
	8	7	22.64	22.32	22.61	1	21.50	21.49	21.42	2	20.83	20.21	20.35	3
	15	0	22.73	22.61	22.59	1	21.64	21.61	21.76	2	20.65	20.48	20.49	3

Band / BW	RB Size	RB Offset	QPSK			3GPP MPR (dB)	16QAM			3GPP MPR (dB)	64QAM			3GPP MPR (dB)
			Low CH	Mid CH	High CH		Low CH	Mid CH	High CH		Low CH	Mid CH	High CH	
			26815	26915	27015		26815	26915	27015		26815	26915	27015	
			826.50	836.50	846.50		826.50	836.50	846.50		826.5	836.5	846.5	
			MHz	MHz	MHz		MHz	MHz	MHz		MHz	MHz	MHz	
26 / 5M	1	0	23.26	23.49	23.73	0	22.55	22.77	22.35	1	21.69	21.79	21.47	2
	1	12	23.52	23.82	23.54	0	22.65	22.60	22.48	1	21.63	21.64	21.55	2
	1	24	23.76	23.51	22.98	0	22.76	22.52	22.67	1	21.23	21.65	21.41	2
	12	0	22.45	22.51	22.59	1	21.93	21.82	21.56	2	20.16	20.34	20.57	3
	12	6	22.49	22.70	22.31	1	21.57	21.63	21.58	2	20.19	20.86	20.70	3
	12	13	22.62	22.50	22.56	1	21.88	21.38	21.44	2	20.33	20.31	20.73	3
	25	0	22.70	22.76	23.47	1	21.50	21.33	21.49	2	20.61	20.63	20.54	3

Band / BW	RB Size	RB Offset	QPSK			3GPP MPR (dB)	16QAM			3GPP MPR (dB)	64QAM			3GPP MPR (dB)
			Low CH	Mid CH	High CH		Low CH	Mid CH	High CH		Low CH	Mid CH	High CH	
			26840	26915	26990		26840	26915	26990		26840	26915	26990	
			829	836.5	844		829	836.5	844		829	836.5	844	
			MHz	MHz	MHz		MHz	MHz	MHz		MHz	MHz	MHz	
26 / 10M	1	0	23.80	23.33	23.73	0	22.40	22.85	22.77	1	21.34	21.85	21.16	2
	1	24	23.69	23.41	23.28	0	22.27	22.77	22.18	1	21.70	21.58	21.18	2
	1	49	23.67	23.79	23.32	0	22.77	22.28	22.21	1	21.52	21.57	21.65	2
	25	0	22.30	22.69	22.40	1	22.05	21.35	21.59	2	20.77	20.22	20.62	3
	25	12	22.64	22.59	22.41	1	21.56	21.40	21.34	2	20.12	20.47	20.17	3
	25	25	22.64	22.67	22.55	1	21.72	21.85	21.76	2	20.08	20.44	20.65	3
	50	0	22.51	22.78	22.45	1	22.76	21.41	21.35	2	20.34	20.13	20.23	3

Band / BW	RB Size	RB Offset	QPSK			3GPP MPR (dB)	16QAM			3GPP MPR (dB)	64QAM			3GPP MPR (dB)
			Low CH	Mid CH	High CH		Low CH	Mid CH	High CH		Low CH	Mid CH	High CH	
			26865	26915	26965		26865	26915	26965		26865	26915	26965	
			831.5	836.5	841.5		831.5	836.5	841.5		831.5	836.5	841.5	
			MHz	MHz	MHz		MHz	MHz	MHz		MHz	MHz	MHz	
26 / 15M	1	0	23.82	23.92	23.61	0	22.36	22.52	22.62	1	21.89	21.36	21.34	2
	1	37	23.40	23.81	23.43	0	22.31	22.65	22.54	1	21.75	21.45	21.48	2
	1	74	23.55	23.72	23.57	0	22.63	22.20	22.36	1	21.59	21.28	21.41	2
	36	0	22.98	22.81	22.61	1	21.66	21.49	21.18	2	20.42	20.60	20.33	3
	36	19	22.89	22.82	22.96	1	21.64	21.60	21.46	2	20.73	20.66	20.29	3
	36	39	22.68	22.57	22.80	1	21.74	21.55	21.68	2	20.19	20.26	20.42	3
	75	0	22.47	22.56	23.47	1	21.67	21.47	21.50	2	20.49	20.40	20.29	3

ERP POWER

WCDMA

Band	WCDMA V		
Channel	4132	4182	4233
Frequency (MHz)	826.4	836.4	846.6
RMC 12.2K	24.10	24.04	24.29
Gain (dBi)	2.68	2.68	2.68
Isotropically Factor (dB)	2.15	2.15	2.15
Max ERP Power (dBm)	24.63	24.57	24.82

LTE Band 5

Band / BW	RB Size	RB Offset	QPSK			3GPP MPR (dB)	16QAM			3GPP MPR (dB)	64QAM			3GPP MPR (dB)	
			Low CH	Mid CH	High CH		Low CH	Mid CH	High CH		Low CH	Mid CH	High CH		
			20407	20525	20643		20407	20525	20643		20407	20525	20643		
5 / 1.4M	1	0	824.7	836.5	848.3	0	824.7	836.5	848.3	1	824.7	836.5	848.3	2	
			MHz	MHz	MHz		MHz	MHz	MHz		MHz	MHz	MHz		MHz
			23.29	23.87	23.83		22.68	22.33	22.34		21.52	21.54	21.35		
			Gain (dBi)	2.68	2.68		2.68	2.68	2.68		2.68	2.68	2.68		
			Isotropically Factor (dB)	2.15	2.15	2.15	2.15	2.15	2.15	2.15	2.15				
			Max ERP Power (dBm)	23.82	24.40	24.36	23.21	22.86	22.87	22.05	22.07	21.88			

Band / BW	RB Size	RB Offset	QPSK			3GPP MPR (dB)	16QAM			3GPP MPR (dB)	64QAM			3GPP MPR (dB)
			Low CH	Mid CH	High CH		Low CH	Mid CH	High CH		Low CH	Mid CH	High CH	
			20415	20525	20635		20415	20525	20635		20415	20525	20635	
5 / 3M	1	0	825.5	836.5	847.5	0	825.5	836.5	847.5	1	825.5	836.5	847.5	2
			MHz	MHz	MHz		MHz	MHz	MHz		MHz	MHz	MHz	
			23.43	23.83	23.62		22.86	22.40	22.55		21.86	21.63	21.55	
			Gain (dBi)	2.68	2.68		2.68	2.68	2.68		2.68	2.68	2.68	
			Isotropically Factor (dB)	2.15	2.15	2.15	2.15	2.15	2.15	2.15	2.15			
			Max ERP Power (dBm)	23.96	24.36	24.15	23.39	22.93	23.08	22.39	22.16	22.08		

Band / BW	RB Size	RB Offset	QPSK			3GPP MPR (dB)	16QAM			3GPP MPR (dB)	64QAM			3GPP MPR (dB)
			Low CH	Mid CH	High CH		Low CH	Mid CH	High CH		Low CH	Mid CH	High CH	
			20425	20525	20625		20425	20525	20625		20425	20525	20625	
5 / 5M	1	0	826.5	836.5	846.5	0	826.5	836.5	846.5	1	826.5	836.5	846.5	2
			MHz	MHz	MHz		MHz	MHz	MHz		MHz	MHz	MHz	
			23.80	23.36	23.32		22.44	22.57	22.39		21.29	21.76	21.21	
			Gain (dBi)	2.68	2.68		2.68	2.68	2.68		2.68	2.68	2.68	
			Isotropically Factor (dB)	2.15	2.15	2.15	2.15	2.15	2.15	2.15	2.15			
			Max ERP Power (dBm)	24.33	23.89	23.85	22.97	23.10	22.92	21.82	22.29	21.74		

Band / BW	RB Size	RB Offset	QPSK			3GPP MPR (dB)	16QAM			3GPP MPR (dB)	64QAM			3GPP MPR (dB)	
			Low CH	Mid CH	High CH		Low CH	Mid CH	High CH		Low CH	Mid CH	High CH		
			20450	20525	20600		20450	20525	20600		20450	20525	20600		
			829 MHz	836.5 MHz	844 MHz		829 MHz	836.5 MHz	844 MHz		829 MHz	836.5 MHz	844 MHz		
5 / 10M	1	0	23.51	23.76	23.45	0	22.30	22.56	23.04	1	21.80	21.23	21.79	2	
Gain (dBi)			2.68	2.68	2.68		2.68	2.68	2.68		2.68	2.68	2.68		2.68
Isotropically Factor (dB)			2.15	2.15	2.15		2.15	2.15	2.15		2.15	2.15	2.15		2.15
Max ERP Power (dBm)			24.04	24.29	23.98		22.83	23.09	23.57		22.33	21.76	22.32		

LTE CA_5C (PCC/SCC: 5M+10M)

Channel Number	Freq. (MHz)	QPSK							
		PCC		SCC		Conducted Power	Gain	ERP(dBm)	ERP(mW)
		RB Number	RB Set	RB Number	RB Set	Chain 0			
20528+20600	836.8+844	1	0	0	0	23.62	2.68	24.15	260.02

LTE CA_5C (PCC/SCC: 10M+10M)

Channel Number	Freq. (MHz)	QPSK							
		PCC		SCC		Conducted Power	Gain	ERP(dBm)	ERP(mW)
		RB Number	RB Set	RB Number	RB Set	Chain 0			
2501+2600	834.1+844	50	0	50	0	20.80	2.68	21.33	135.83

LTE Band 26

Band / BW	RB Size	RB Offset	QPSK			3GPP MPR (dB)	16QAM			3GPP MPR (dB)	64QAM			3GPP MPR (dB)
			Low CH	Mid CH	High CH		Low CH	Mid CH	High CH		Low CH	Mid CH	High CH	
			26797	26915	27033		26797	26915	27033		26797	26915	27033	
26 / 1.4M	1	0	824.7	836.5	848.3	0	824.7	836.5	848.3	1	824.7	836.5	848.3	2
Gain (dBi)			23.84	23.26	23.45		22.75	22.51	22.32		21.34	21.58	21.47	
Isotropically Factor (dB)			2.92	2.92	2.92		2.92	2.92	2.92		2.92	2.92	2.92	
Max ERP Power (dBm)			2.15	2.15	2.15		2.15	2.15	2.15		2.15	2.15	2.15	
			24.61	24.03	24.22		23.52	23.28	23.09		22.11	22.35	22.24	

Band / BW	RB Size	RB Offset	QPSK			3GPP MPR (dB)	16QAM			3GPP MPR (dB)	64QAM			3GPP MPR (dB)
			Low CH	Mid CH	High CH		Low CH	Mid CH	High CH		Low CH	Mid CH	High CH	
			26805	26915	27025		26805	26915	27025		26805	26915	27025	
26 / 3M	1	0	825.5	836.5	847.5	0	825.5	836.5	847.5	1	825.5	836.5	847.5	2
Gain (dBi)			0	0	0		0	0	0		5	5	5	
Isotropically Factor (dB)			23.99	23.51	23.53		22.41	22.48	22.28		21.47	21.37	21.64	
Max ERP Power (dBm)			2.92	2.92	2.92		2.92	2.92	2.92		2.92	2.92	2.92	
			2.15	2.15	2.15		2.15	2.15	2.15		2.15	2.15	2.15	

Band / BW	RB Size	RB Offset	QPSK			3GPP MPR (dB)	16QAM			3GPP MPR (dB)	64QAM			3GPP MPR (dB)
			Low CH	Mid CH	High CH		Low CH	Mid CH	High CH		Low CH	Mid CH	High CH	
			26815	26915	27015		26815	26915	27015		26815	26915	27015	
26 / 5M	1	12	826.5	836.5	846.5	0	826.5	836.5	846.5	1	826.5	836.5	846.5	2
Gain (dBi)			0	0	0		0	0	0		5	5	5	
Isotropically Factor (dB)			23.26	23.49	23.73		22.55	22.77	22.35		21.69	21.79	21.47	
Max ERP Power (dBm)			2.92	2.92	2.92		2.92	2.92	2.92		2.92	2.92	2.92	
			2.15	2.15	2.15		2.15	2.15	2.15		2.15	2.15	2.15	

Band / BW	RB Size	RB Offset	QPSK			3GPP MPR (dB)	16QAM			3GPP MPR (dB)	64QAM			3GPP MPR (dB)
			Low CH	Mid CH	High CH		Low CH	Mid CH	High CH		Low CH	Mid CH	High CH	
			26840	26915	26990		26840	26915	26990		26840	26915	26990	
26 / 10M	1	0	829	836.5	844	0	829	836.5	844	1	829	836.5	844	2
Gain (dBi)			23.80	23.33	23.73		22.40	22.85	22.77		21.34	21.85	21.16	
Isotropically Factor (dB)			2.92	2.92	2.92		2.92	2.92	2.92		2.92	2.92	2.92	
Max ERP Power (dBm)			2.15	2.15	2.15		2.15	2.15	2.15		2.15	2.15	2.15	
			24.57	24.10	24.50		23.17	23.62	23.54		22.11	22.62	21.93	

Band / BW	RB Size	RB Offset	QPSK			3GPP MPR (dB)	16QAM			3GPP MPR (dB)	64QAM			3GPP MPR (dB)
			Low CH	Mid CH	High CH		Low CH	Mid CH	High CH		Low CH	Mid CH	High CH	
			26865	26915	26965		26865	26915	26965		26865	26915	26965	
			831.5 MHz	836.5 MHz	841.5 MHz		831.5 MHz	836.5 MHz	841.5 MHz		831.5 MHz	836.5 MHz	841.5 MHz	
26 / 15M	1	0	23.82	23.92	23.61	0	22.36	22.52	22.62	1	21.89	21.36	21.34	2
Gain (dBi)			2.92	2.92	2.92		2.92	2.92	2.92					
Isotropically Factor (dB)			2.15	2.15	2.15		2.15	2.15	2.15					
Max ERP Power (dBm)			24.59	24.69	24.38		23.13	23.29	23.39		22.66	22.13	22.11	

4.2 Modulation characteristics Measurement

4.2.1 Limits of Modulation characteristics

N/A

4.2.2 Test Procedure

Connect the EUT to Communication Simulator via the antenna connector, The frequency band is set as EUT supported Modulation and Channels, the EUT output is matched with 50 ohm load, the waveform quality and constellation of the EUT was tested.

4.2.3 Test Setup



4.2.4 Test Results

WCDMA B5

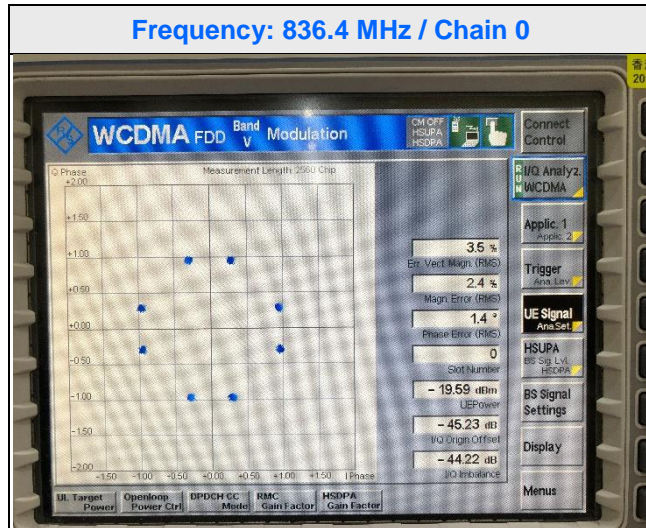

LTE Band 5

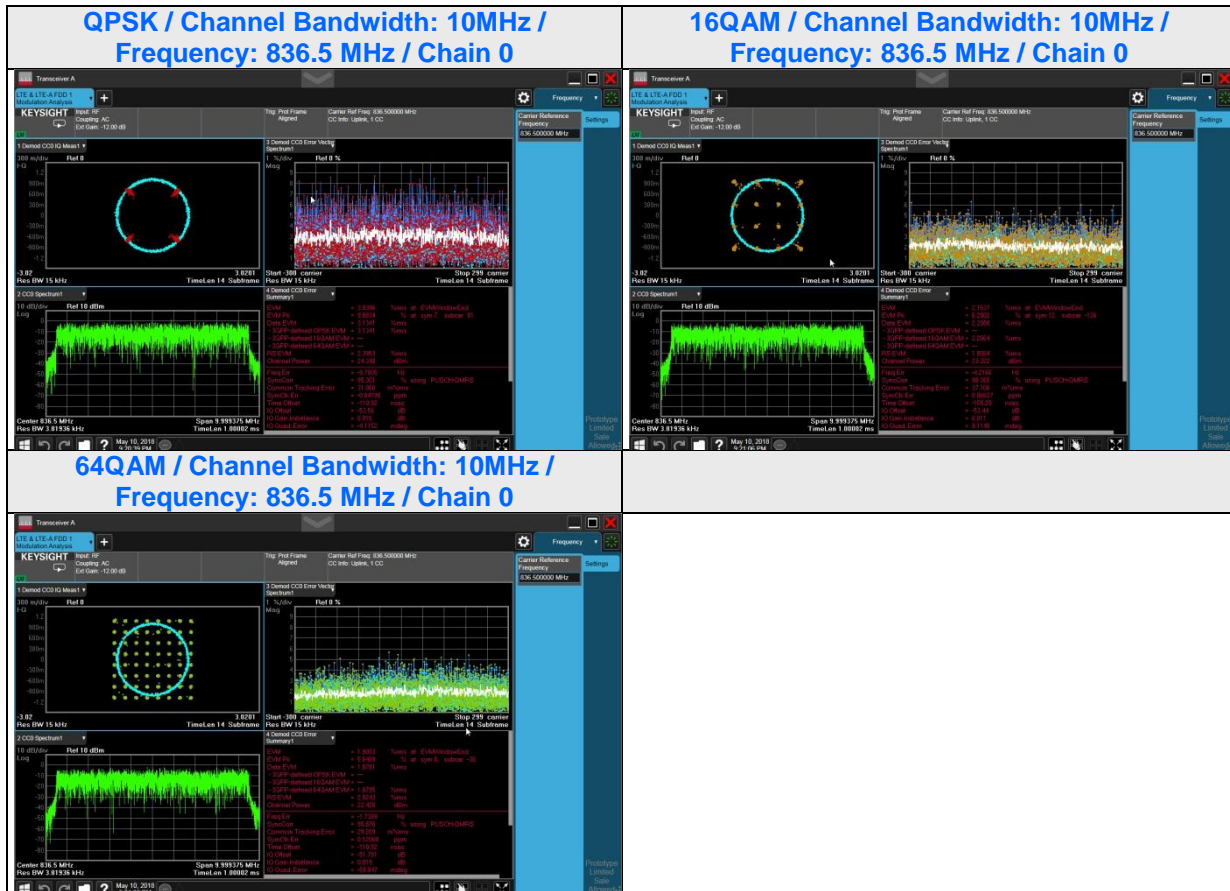

LTE Band 26

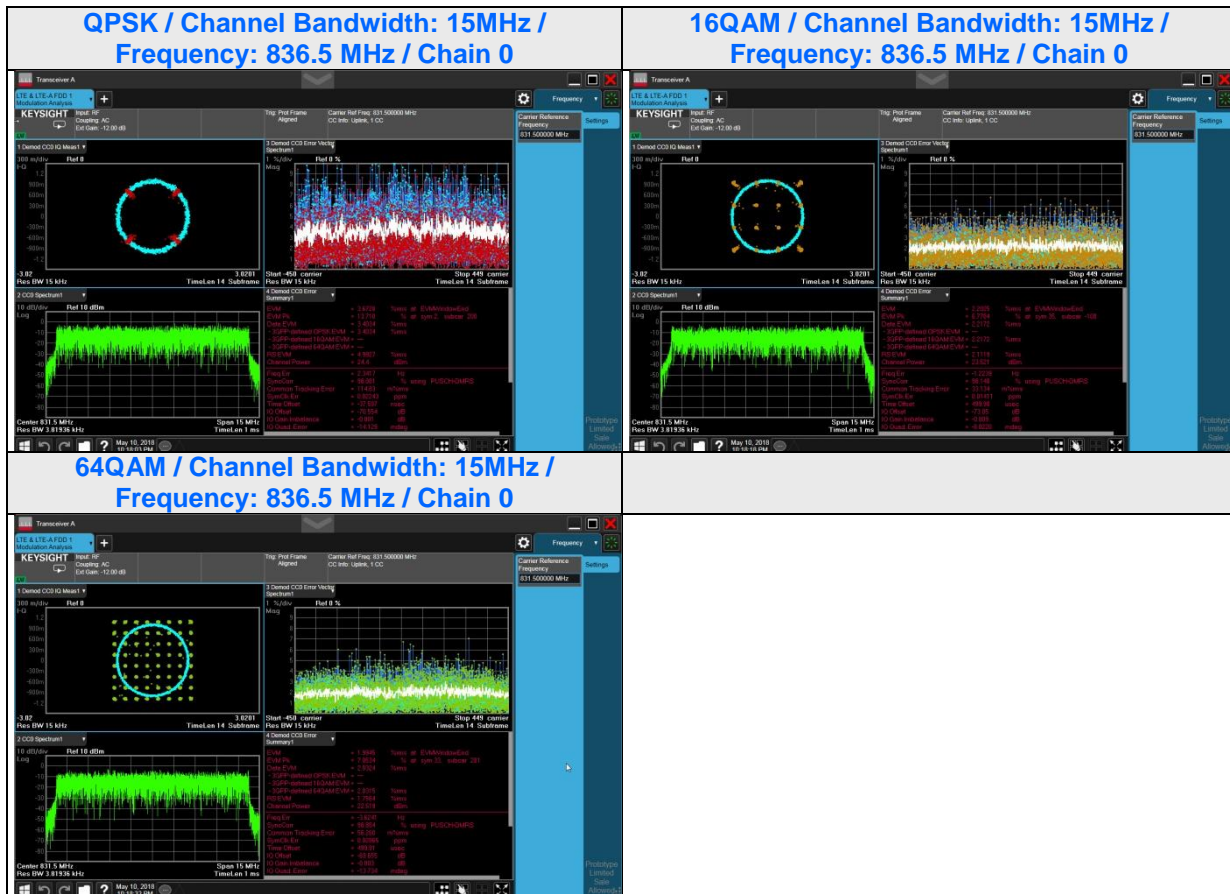

4.3 Frequency Stability Measurement

4.3.1 Limits of Frequency Stability Measurement

1.5 ppm is for base and fixed station. 2.5 ppm is for mobile station.

4.3.2 Test Procedure

- Device is placed at the oven room. The oven room could control the temperatures and humidity. Power warm up is at least 15 min and power applied should perform before recording frequency error.
- EUT is connected the external power supply to control the DC input power. The test voltage range is from minimum to maximum working voltage. Each step shall be record the frequency error rate.
- The temperature range step is 10 degrees in this test items. All temperature levels shall be hold the ± 0.5 °C during the measurement testing. The each temperature step shall be at least 0.5 hours, consider the EUT could be test under the stability condition.

NOTE: The frequency error was recorded frequency error from the communication simulator.

4.3.3 Test Setup

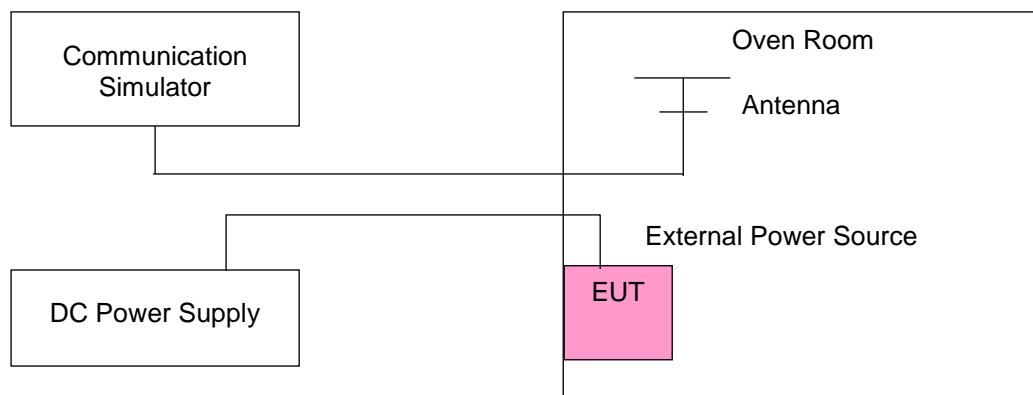

4.3.4 Test Results

WCDMA

Frequency Error vs. Voltage

Voltage (Volts)	Frequency Error (ppm)	Limit (ppm)
	WCDMA B5	
2.805	0.050	2.5
3.795	0.039	2.5

Frequency Error vs. Temperature.

TEMP. (°C)	Frequency Error (ppm)	Limit (ppm)
	WCDMA B5	
50	0.038	2.5
40	0.035	2.5
30	0.044	2.5
20	0.044	2.5
10	0.036	2.5
0	0.053	2.5
-10	0.054	2.5
-20	0.048	2.5
-30	0.035	2.5

LTE Band 5

Frequency Error vs. Voltage

Voltage (Volts)	Frequency Error (ppm)				Limit (ppm)
	LTE Band 5				
	1.4MHz	3MHz	5MHz	10MHz	
2.805	0.032	0.039	0.030	0.025	2.5
3.795	0.044	0.048	0.050	0.036	2.5

Frequency Error vs. Temperature

Temp. (°C)	Frequency Error (ppm)				Limit (ppm)
	LTE Band 5				
	1.4MHz	3MHz	5MHz	10MHz	
50	0.036	0.029	0.033	0.024	2.5
40	0.030	0.032	0.026	0.042	2.5
30	0.055	0.024	0.045	0.056	2.5
20	0.037	0.045	0.051	0.048	2.5
10	0.059	0.030	0.039	0.053	2.5
0	0.050	0.024	0.043	0.057	2.5
-10	0.049	0.036	0.042	0.037	2.5
-20	0.029	0.035	0.042	0.035	2.5
-30	0.030	0.036	0.025	0.056	2.5

LTE CA_5C

Frequency Error vs. Voltage

Voltage (Volts)	Frequency Error (ppm)		Limit (ppm)
	CA_5+10 MHz Low Channel	CA_5+10 MHz High Channel	
2.805	0.047	0.027	2.5
3.795	0.049	0.051	2.5

Frequency Error vs. Temperature.

Temp. (°C)	Frequency Error (ppm)		Limit (ppm)
	CA_5+10 MHz Low Channel	CA_5+10 MHz High Channel	
50	0.049	0.037	2.5
40	0.047	0.026	2.5
30	0.036	0.046	2.5
20	0.038	0.058	2.5
10	0.036	0.057	2.5
0	0.051	0.043	2.5
-10	0.045	0.047	2.5
-20	0.030	0.058	2.5
-30	0.030	0.040	2.5

LTE Band 26

Frequency Error vs. Voltage

Voltage (Volts)	Frequency Error (ppm)					Limit (ppm)
	LTE Band 26					
	1.4MHz	3MHz	5MHz	10MHz	15MHz	
2.805	0.054	0.050	0.030	0.057	0.024	2.5
3.795	0.051	0.051	0.042	0.038	0.048	2.5

Frequency Error vs. Temperature

Temp. (°C)	Frequency Error (ppm)					Limit (ppm)
	LTE Band 5					
	1.4MHz	3MHz	5MHz	10MHz	15MHz	
50	0.059	0.053	0.027	0.057	0.048	2.5
40	0.039	0.038	0.054	0.059	0.025	2.5
30	0.037	0.057	0.030	0.059	0.042	2.5
20	0.035	0.050	0.054	0.025	0.050	2.5
10	0.054	0.047	0.054	0.039	0.038	2.5
0	0.039	0.047	0.031	0.036	0.043	2.5
-10	0.031	0.059	0.024	0.041	0.036	2.5
-20	0.056	0.050	0.051	0.041	0.029	2.5
-30	0.026	0.050	0.037	0.041	0.024	2.5

4.4 Occupied Bandwidth Measurement

4.4.1 Test Procedure

All measurements were done at low, middle and high operational frequency range. The communication simulator station system controlled a EUT to export maximum output power under transmission mode and specific channel frequency. The bandwidth of the fundamental frequency was measured by spectrum analyzer with $RBW \geq 1\% \times OBW$ and $VBW \geq 3 \times VBW$.

Occupied Bandwidth Measurement:

Use OBW measurement function of Spectrum analyzer to measure 99 % occupied bandwidth.

26dB Bandwidth Measurement:

The emission bandwidth is defined as the width of the signal between two points, one below the carrier center frequency and one above the carrier center frequency, outside of which all emission are attenuated at least 26dB below the transmitter power.

4.4.2 Test Setup

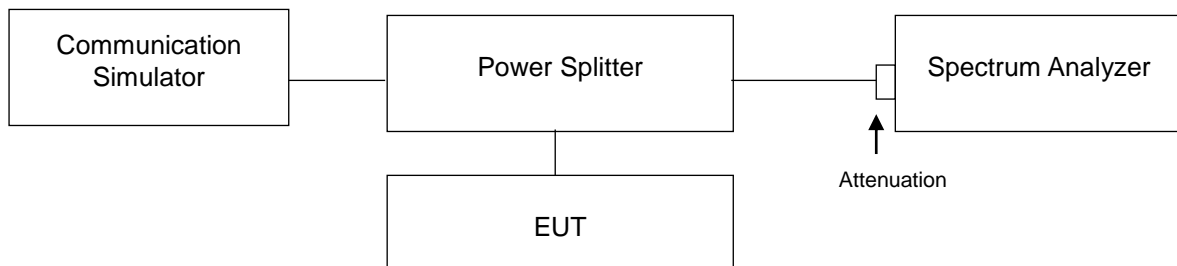

4.4.3 Test Result (-26dB Bandwidth)

Channel	Freq. (MHz)	-26dB Bandwidth (MHz)
		WCDMA B5
4132	826.4	4.67
4182	836.4	4.66
4233	846.6	4.67

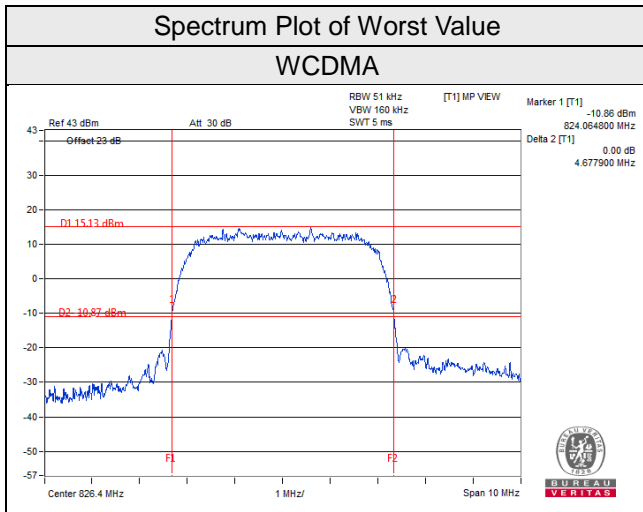

LTE Band 5									
Channel Bandwidth 1.4MHz					Channel Bandwidth 3MHz				
Channel	Frequency (MHz)	-26dB Bandwidth (MHz)			Channel	Frequency (MHz)	-26dB Bandwidth (MHz)		
		QPSK	16QAM	64QAM			QPSK	16QAM	64QAM
20407	824.7	1.23	1.24	1.23	20415	825.5	3.01	2.96	2.99
20525	836.5	1.24	1.24	1.23	20525	836.5	3.00	2.97	2.99
20643	848.3	1.25	1.24	1.25	20635	847.5	3.00	2.96	2.99
Channel Bandwidth 5MHz					Channel Bandwidth 10MHz				
Channel	Frequency (MHz)	-26dB Bandwidth (MHz)			Channel	Frequency (MHz)	-26dB Bandwidth (MHz)		
		QPSK	16QAM	64QAM			QPSK	16QAM	64QAM
20425	826.5	4.92	4.95	4.96	20450	829	9.80	9.85	9.38
20525	836.5	4.92	4.95	4.96	20525	836.5	9.82	9.81	9.43
20625	846.5	4.93	4.91	4.91	20600	844	9.85	9.81	9.39

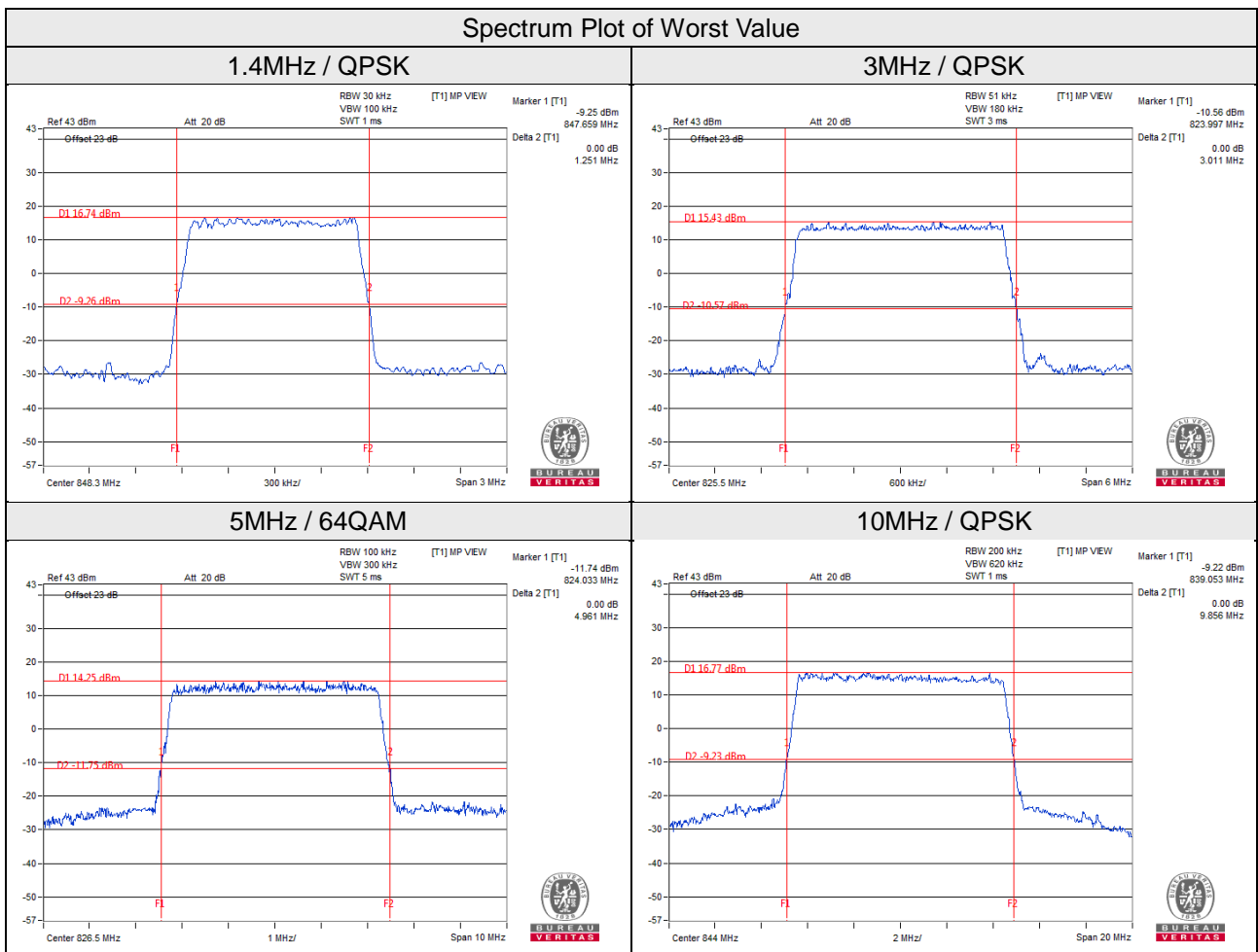

LTE CA_5C (5+10MHz)		
Channel	FREQ. (MHz)	-26dB Bandwidth (MHz)
		QPSK
20528+20600	836.8+844	14.86

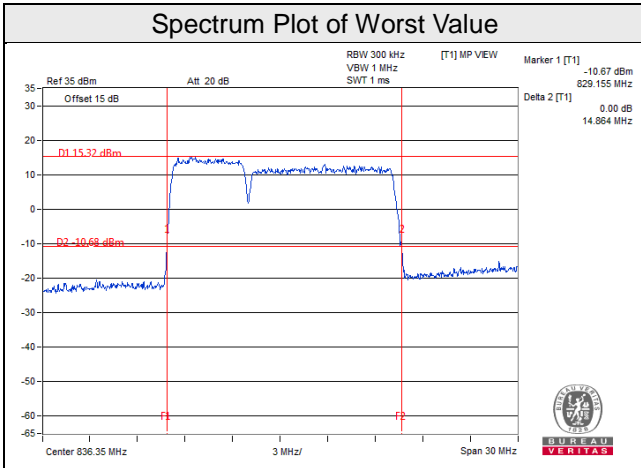

LTE CA_5C (10+10MHz)		
Channel	FREQ. (MHz)	-26dB Bandwidth (MHz)
		QPSK
2501+2600	834.1+844	20.10

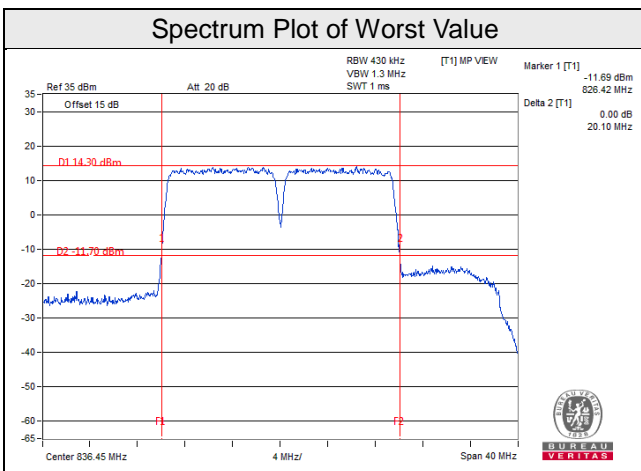

LTE Band 26									
Channel Bandwidth 1.4MHz					Channel Bandwidth 3MHz				
Channel	Frequency (MHz)	-26dB Bandwidth (MHz)			Channel	Frequency (MHz)	-26dB Bandwidth (MHz)		
		QPSK	16QAM	64QAM			QPSK	16QAM	64QAM
26797	824.7	1.24	1.24	1.24	26805	825.5	2.97	2.98	2.96
26915	836.5	1.24	1.24	1.24	26915	836.5	2.97	2.97	2.99
27033	848.3	1.23	1.23	1.25	27025	847.5	3.00	2.97	2.95
Channel Bandwidth 5MHz					Channel Bandwidth 10MHz				
Channel	Frequency (MHz)	-26dB Bandwidth (MHz)			Channel	Frequency (MHz)	-26dB Bandwidth (MHz)		
		QPSK	16QAM	64QAM			QPSK	16QAM	64QAM
26815	826.5	4.96	4.92	4.92	26840	829	9.78	9.79	9.78
26915	836.5	4.91	4.92	4.96	26915	836.5	9.83	9.84	9.80
27015	846.5	4.96	4.93	4.92	26990	844	9.83	9.83	9.73
Channel Bandwidth 15MHz									
Channel	Frequency (MHz)	-26dB Bandwidth (MHz)							
		QPSK	16QAM	64QAM					
26865	831.5	14.75	14.59	14.72					
26915	836.5	14.67	14.63	14.65					
26965	841.5	14.72	14.58	14.79					

Spectrum Plot of Worst Value

1.4MHz / 64QAM

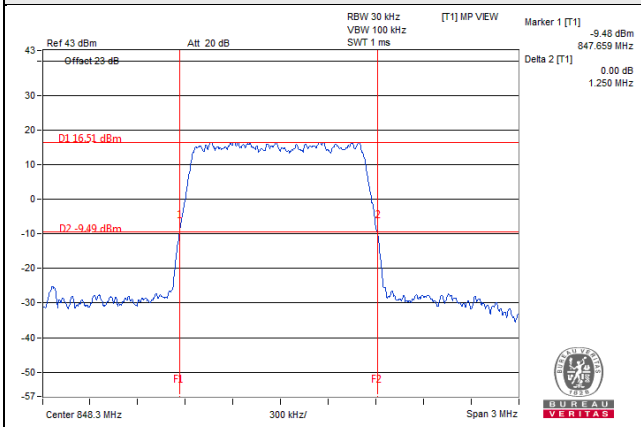

3MHz / QPSK

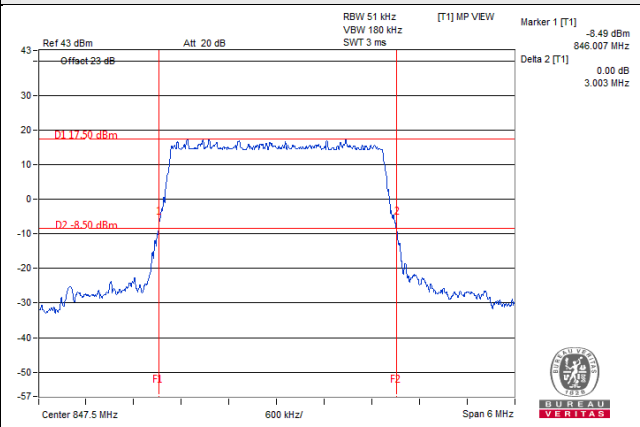

5MHz / QPSK

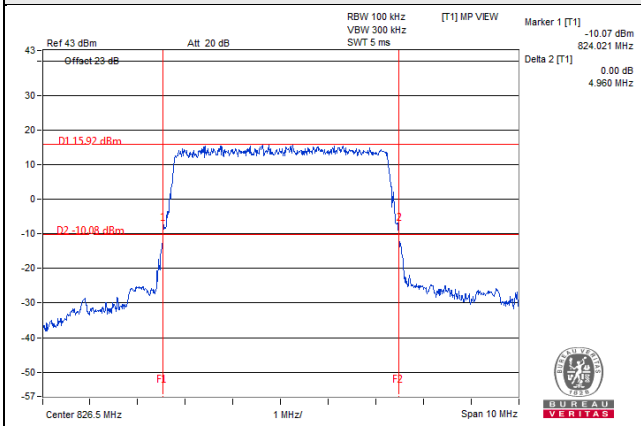

10MHz / 16QAM

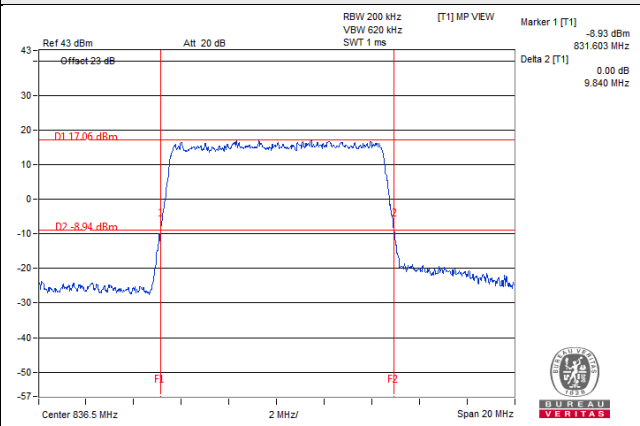

15MHz / 64QAM

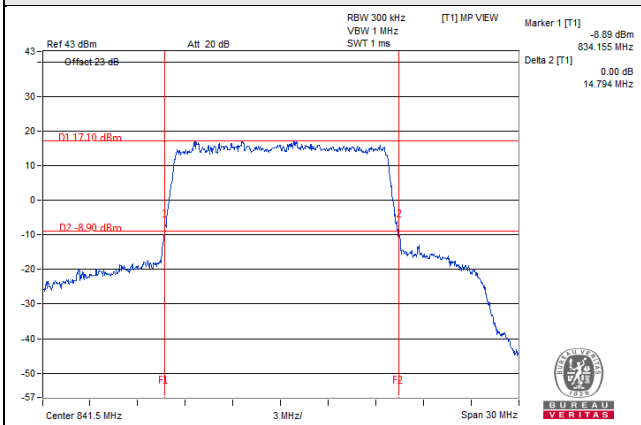

4.4.4 Test Result (Occupied Bandwidth)

Channel	Freq. (MHz)	99% Occupied Bandwidth (MHz)
		WCDMA
4132	826.4	4.13
4182	836.4	4.13
4233	846.6	4.13

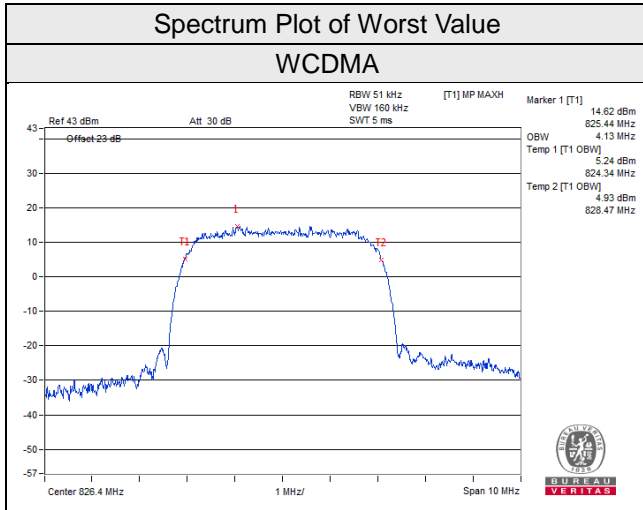

LTE Band 5									
Channel Bandwidth 1.4MHz					Channel Bandwidth 3MHz				
Channel	Frequency (MHz)	99% Occupied Bandwidth (MHz)			Channel	Frequency (MHz)	99% Occupied Bandwidth (MHz)		
		QPSK	16QAM	64QAM			QPSK	16QAM	64QAM
20407	824.7	1.08	1.09	1.09	20415	825.5	2.70	2.68	2.70
20525	836.5	1.08	1.09	1.09	20525	836.5	2.70	2.68	2.70
20643	848.3	1.08	1.09	1.09	20635	847.5	2.70	2.68	2.70
Channel Bandwidth 5MHz					Channel Bandwidth 10MHz				
Channel	Frequency (MHz)	99% Occupied Bandwidth (MHz)			Channel	Frequency (MHz)	99% Occupied Bandwidth (MHz)		
		QPSK	16QAM	64QAM			QPSK	16QAM	64QAM
20425	826.5	4.49	4.49	4.50	20450	829	9.00	8.98	8.98
20525	836.5	4.50	4.51	4.50	20525	836.5	9.00	9.02	9.02
20625	846.5	4.50	4.51	4.50	20600	844	8.98	9.00	8.98

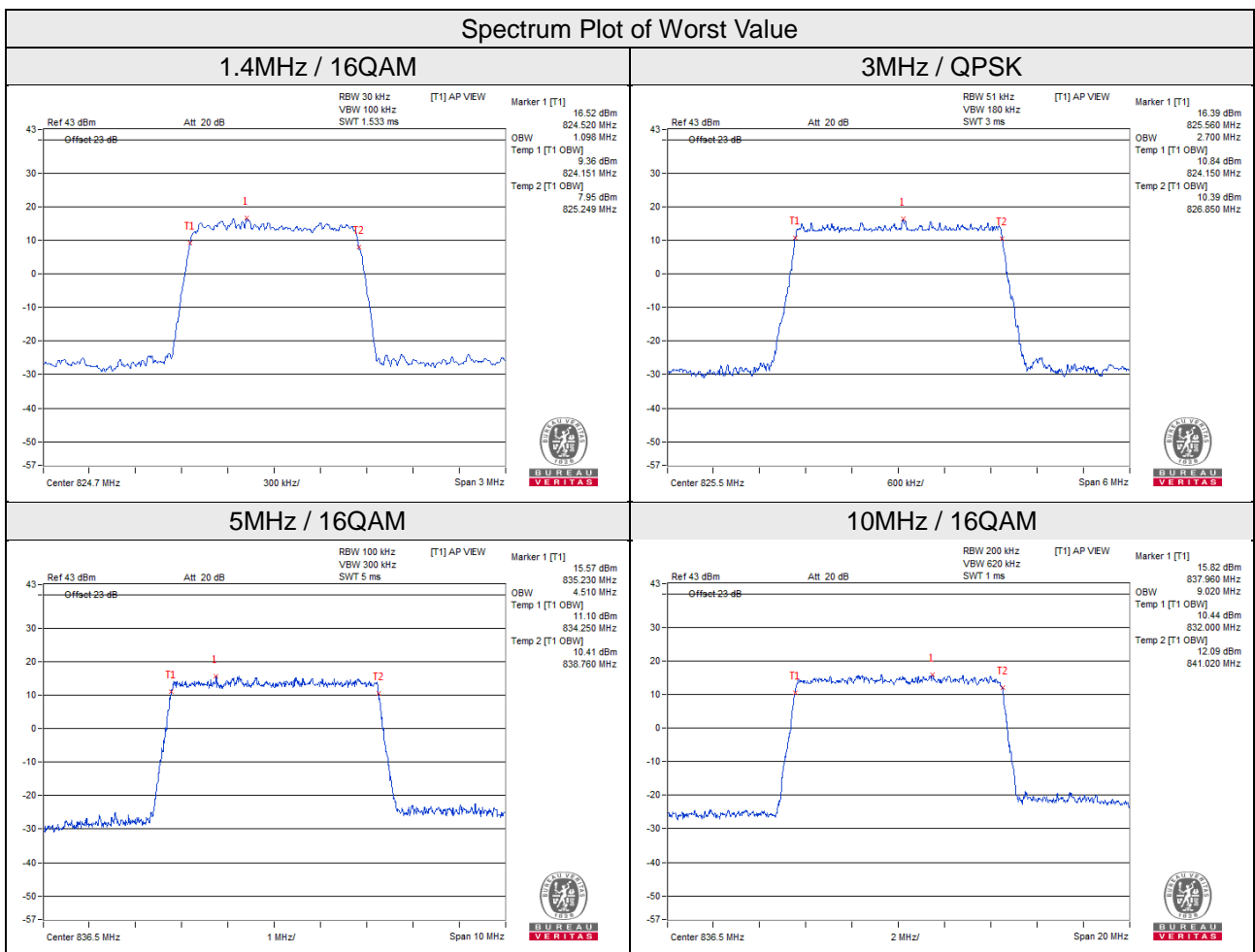

LTE CA_5C (5+10MHz)		
Channel	FREQ. (MHz)	99% Occupied Bandwidth (MHz)
		QPSK
20528+20600	836.8+844	13.95

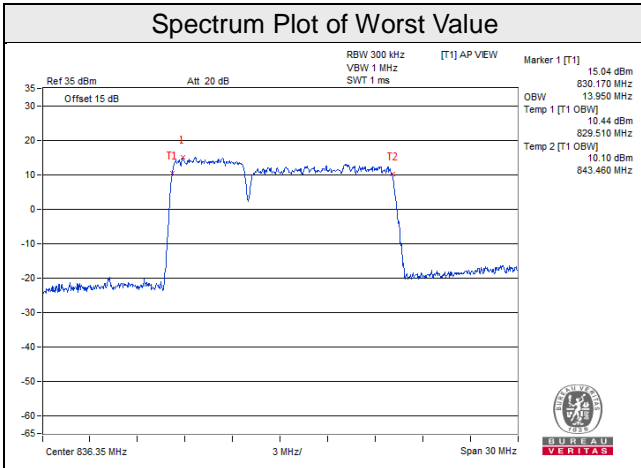

LTE CA_5C (10+10MHz)		
Channel	FREQ. (MHz)	99% Occupied Bandwidth (MHz)
		QPSK
2501+2600	834.1+844	18.92

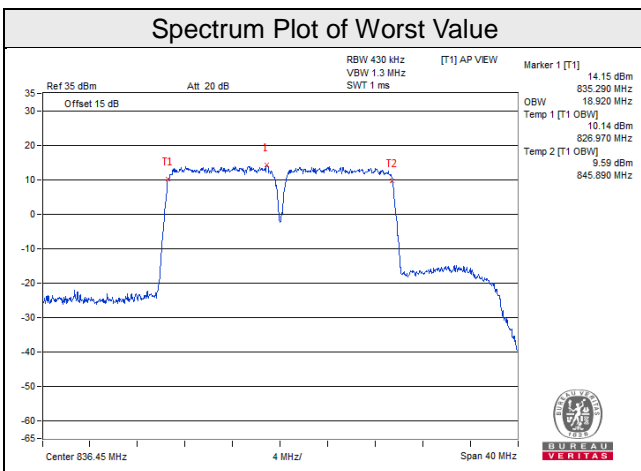

LTE Band 26									
Channel Bandwidth 1.4MHz					Channel Bandwidth 3MHz				
Channel	Frequency (MHz)	99% Occupied Bandwidth (MHz)			Channel	Frequency (MHz)	99% Occupied Bandwidth (MHz)		
		QPSK	16QAM	64QAM			QPSK	16QAM	64QAM
26797	824.7	1.09	1.08	1.08	26805	825.5	2.70	2.68	2.70
26915	836.5	1.08	1.09	1.08	26915	836.5	2.70	2.68	2.70
27033	848.3	1.08	1.09	1.09	27025	847.5	2.70	2.68	2.69
Channel Bandwidth 5MHz					Channel Bandwidth 10MHz				
Channel	Frequency (MHz)	99% Occupied Bandwidth (MHz)			Channel	Frequency (MHz)	99% Occupied Bandwidth (MHz)		
		QPSK	16QAM	64QAM			QPSK	16QAM	64QAM
26815	826.5	4.51	4.49	4.51	26840	829	9.00	9.00	8.98
26915	836.5	4.51	4.51	4.50	26915	836.5	9.00	8.98	9.00
27015	846.5	4.51	4.50	4.49	26990	844	8.98	9.00	8.98
Channel Bandwidth 15MHz									
Channel	Frequency (MHz)	99% Occupied Bandwidth (MHz)							
		QPSK	16QAM	64QAM					
26865	831.5	13.47	13.44	13.47					
26915	836.5	13.47	13.44	13.50					
26965	841.5	13.47	13.47	13.47					

Spectrum Plot of Worst Value

1.4MHz / QPSK

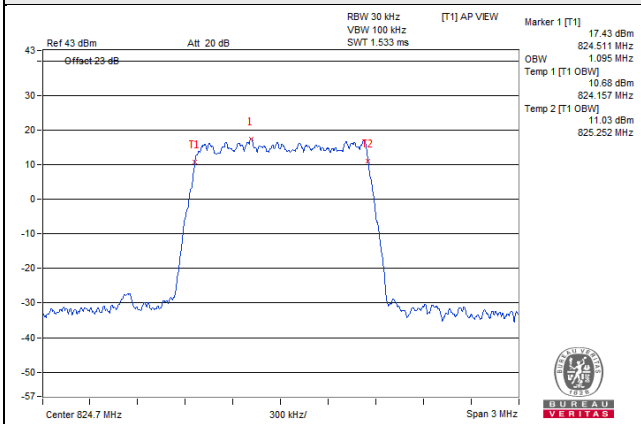

3MHz / QPSK

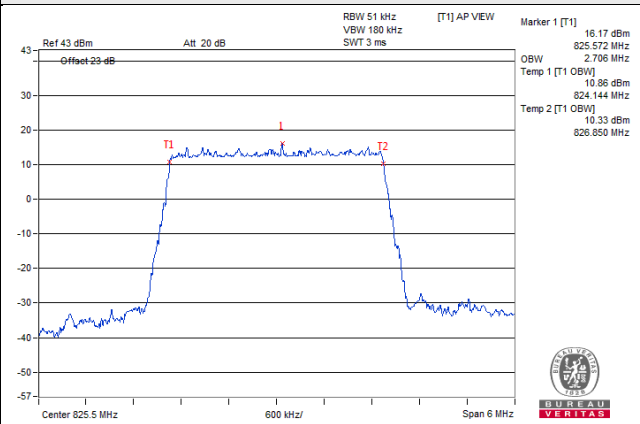

5MHz / QPSK

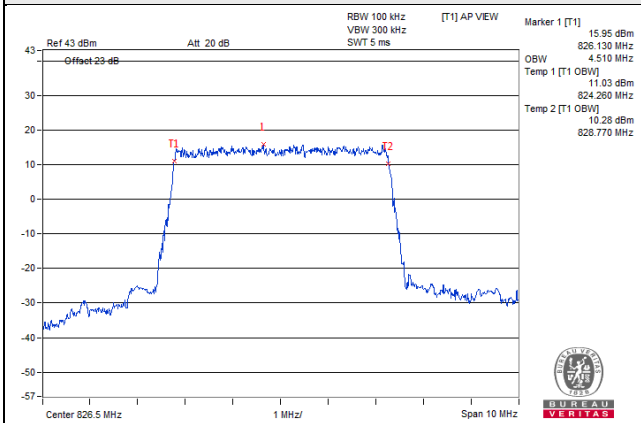

10MHz / QPSK

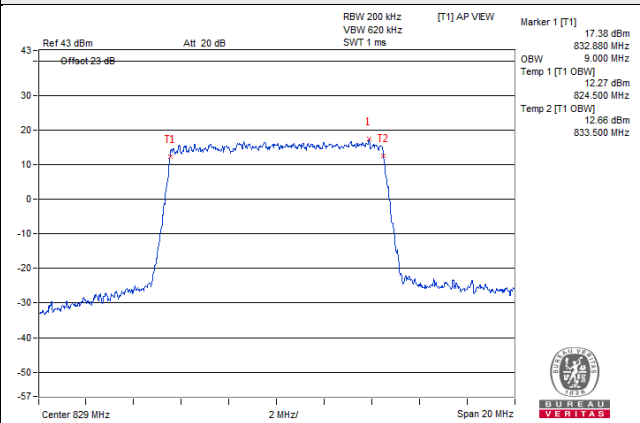

15MHz / 64QAM

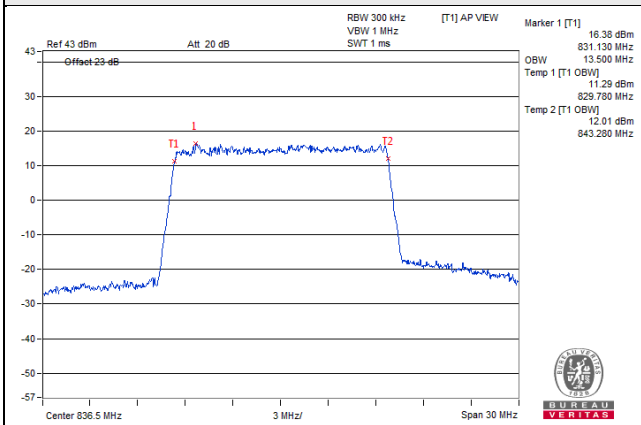

4.5 Band Edge Measurement

4.5.1 Limits of Band Edge Measurement

Power of any emission outside of the authorized operating frequency ranges must be attenuated below the transmitting power (P) by a factor of at least $43 + 10 \log(P)$ dB. In the 1 MHz bands immediately outside and adjacent to the frequency block a resolution bandwidth of at least one percent of the emission bandwidth of the fundamental emission of the transmitter may be employed.

4.5.2 Test Setup

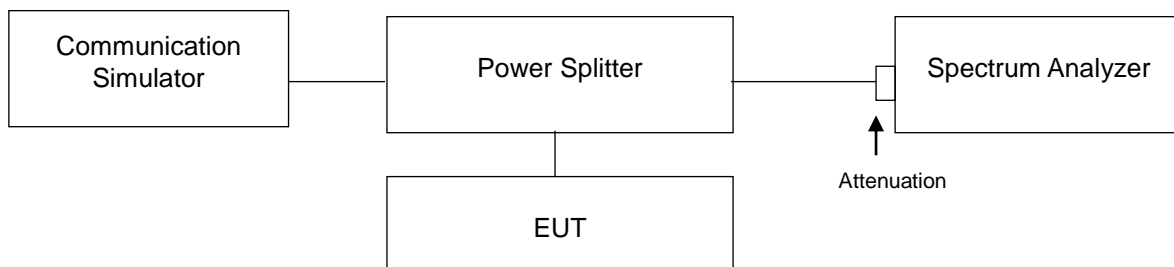

4.5.3 Test Procedures

- a. All measurements were done at low and high operational frequency range.
- b. The center frequency of spectrum is the band edge frequency and RB of the spectrum is $>1\%$ Emission Bandwidth and VB of the spectrum is $\geq 3*RB$.
- c. Record the max trace plot into the test report.

4.5.4 Test Results

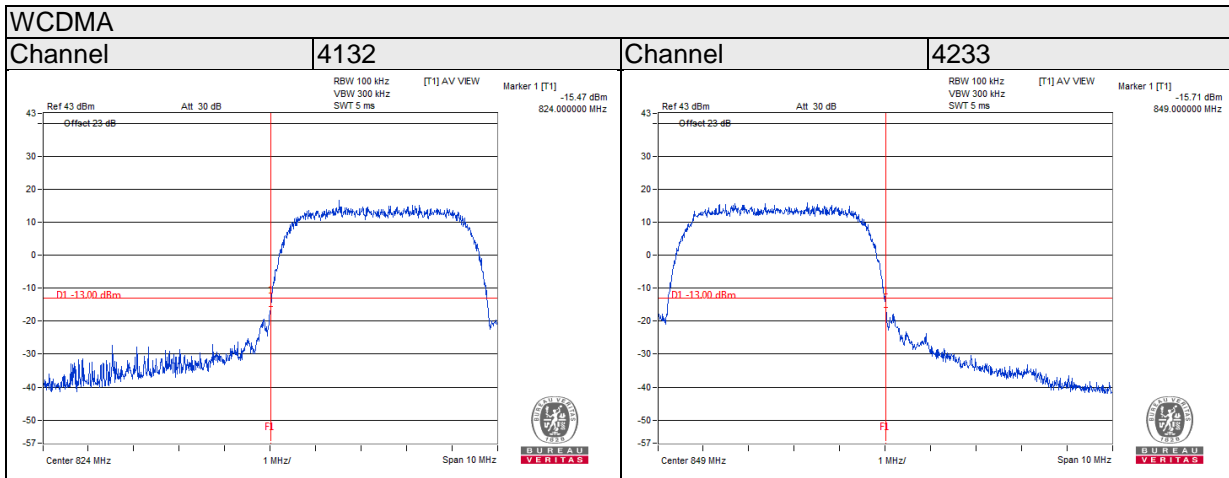

LTE Band 5

Channel Bandwidth 1.4MHz

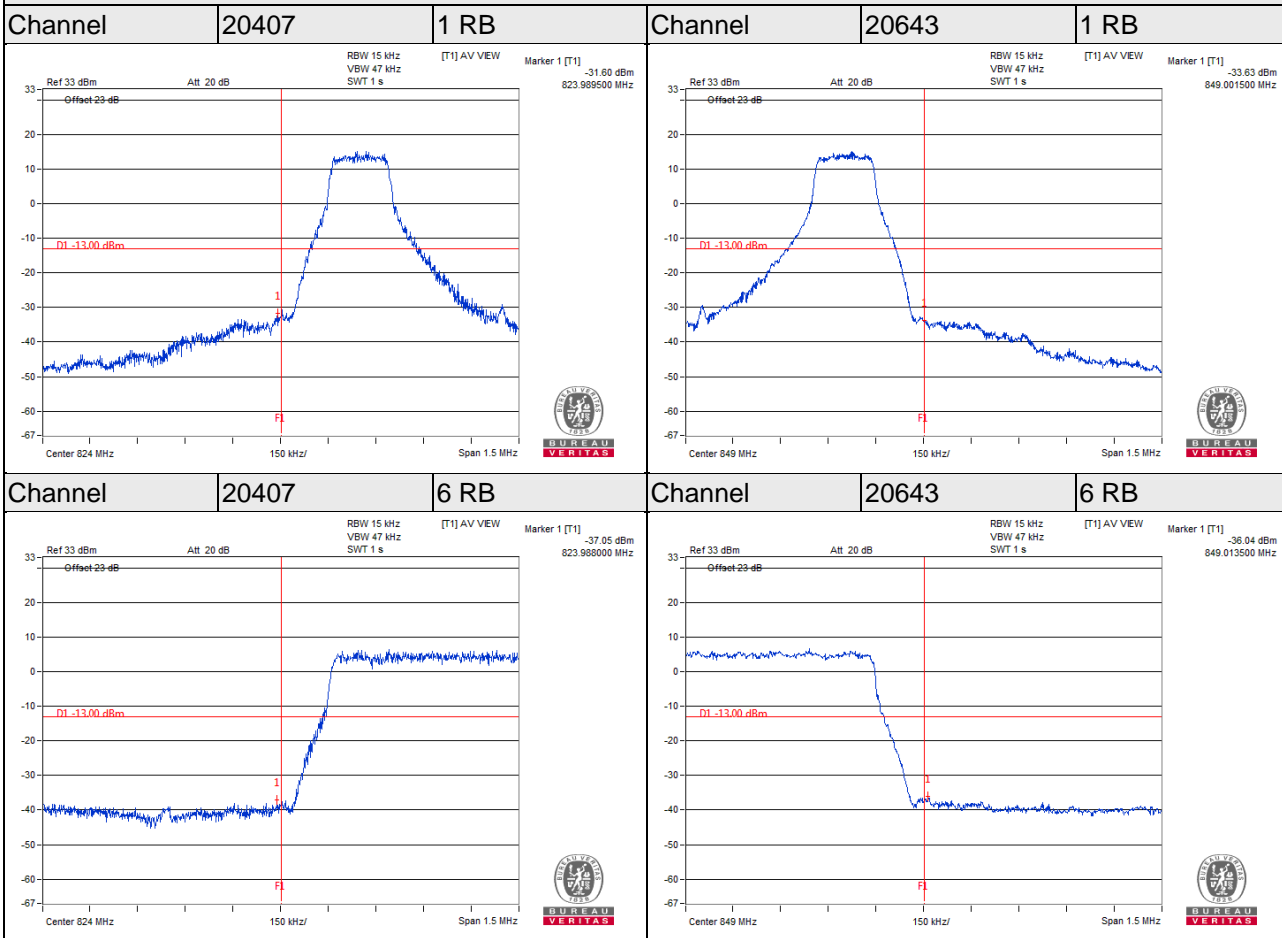

LTE Band 5

Channel Bandwidth 3MHz

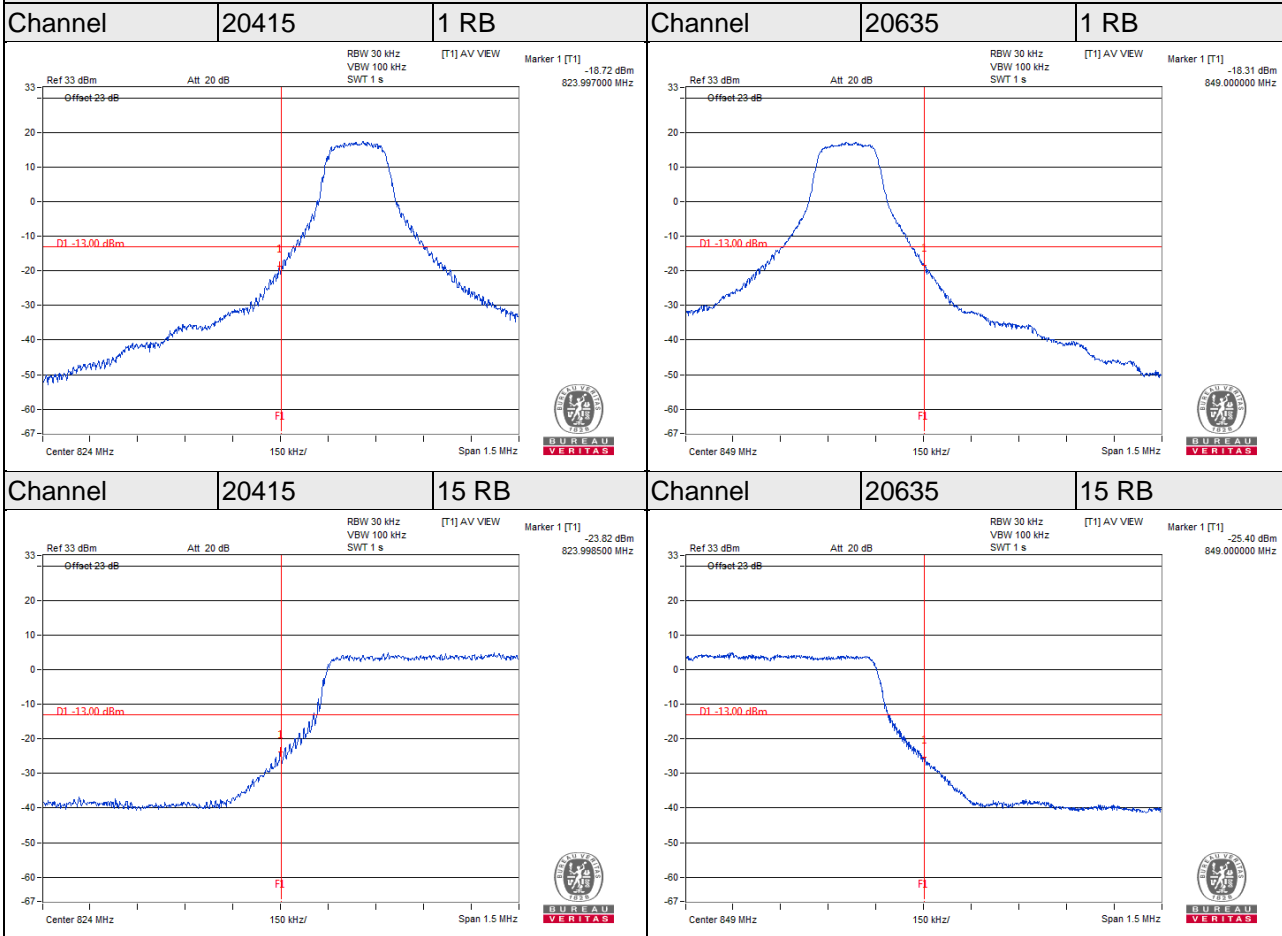

LTE Band 5

Channel Bandwidth 5MHz

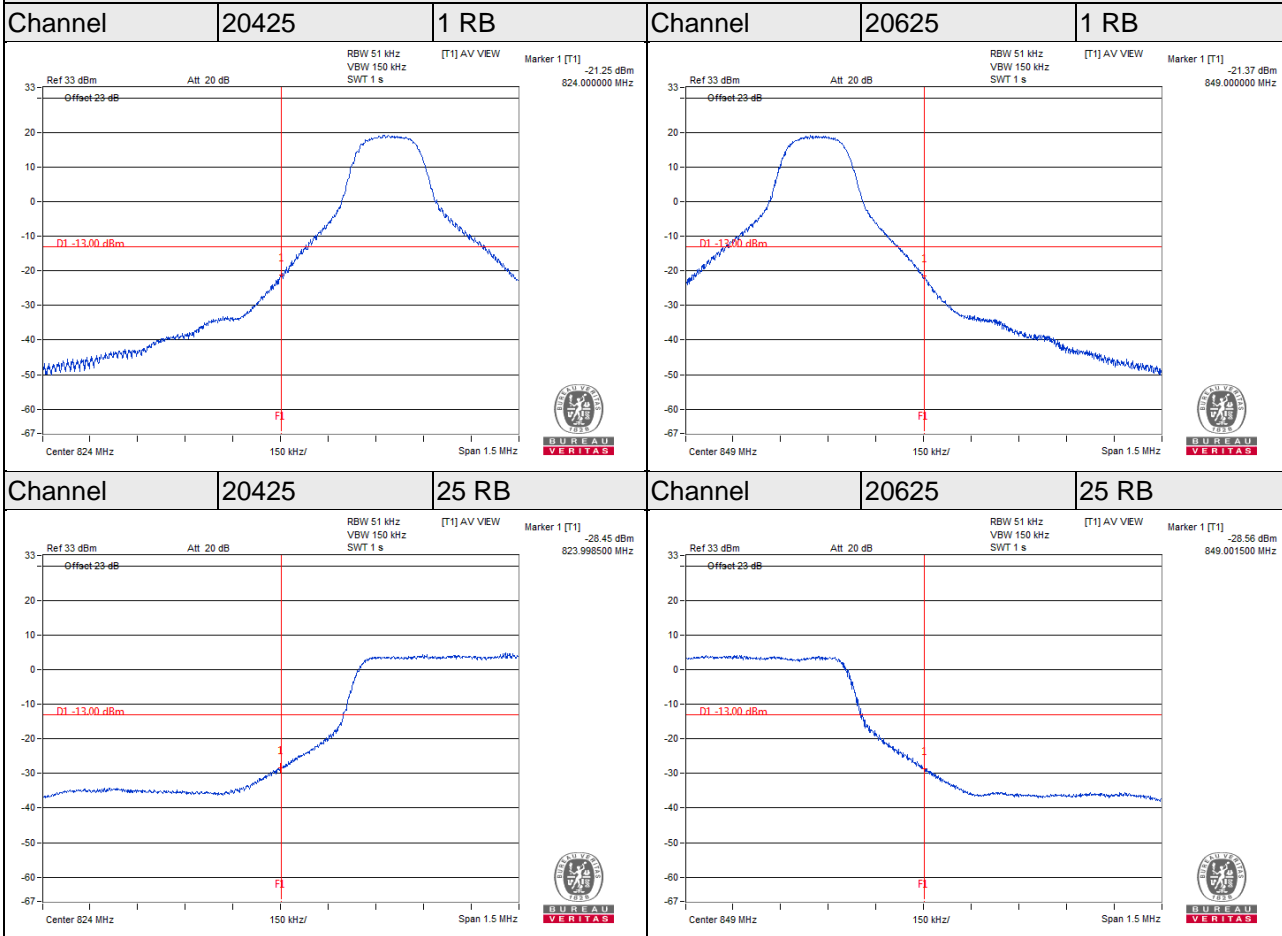

LTE Band 5

Channel Bandwidth 10MHz

Channel	20450	1 RB	Channel	20600	1 RB
---------	-------	------	---------	-------	------

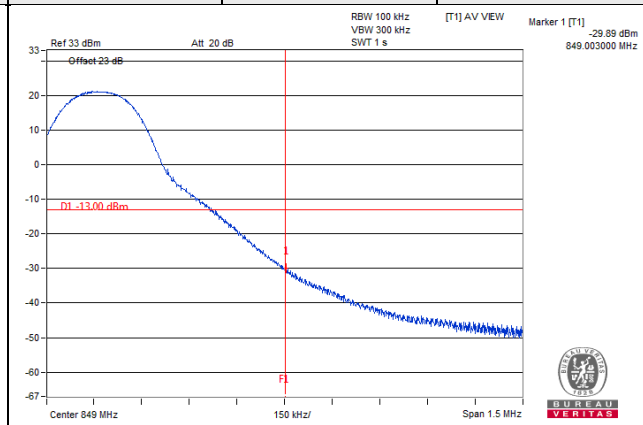
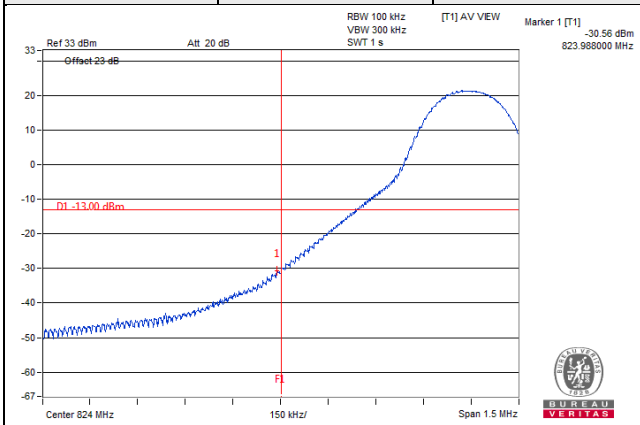

Channel	20450	50 RB	Channel	20600	50 RB
---------	-------	-------	---------	-------	-------

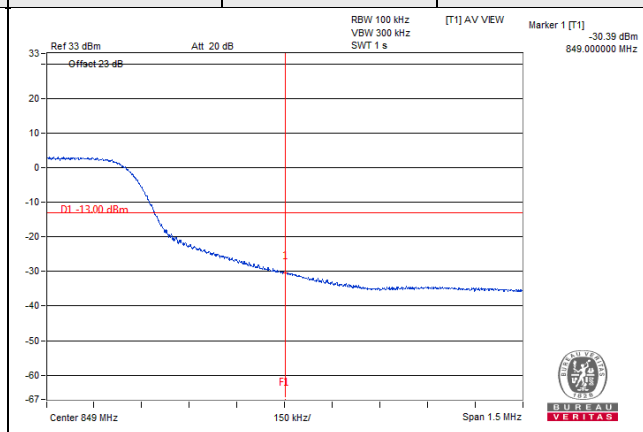
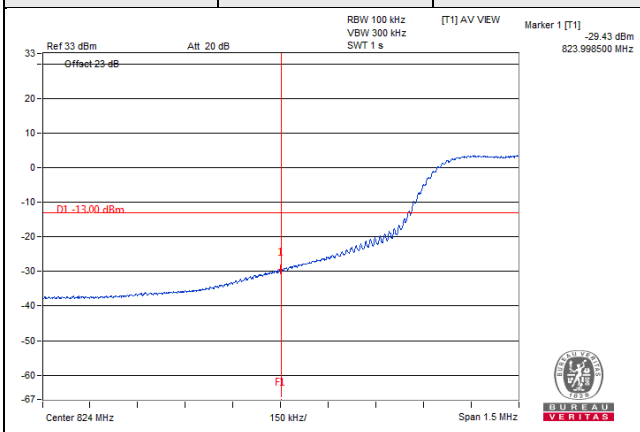

LTE CA_5C

Channel Bandwidth 5+10MHz

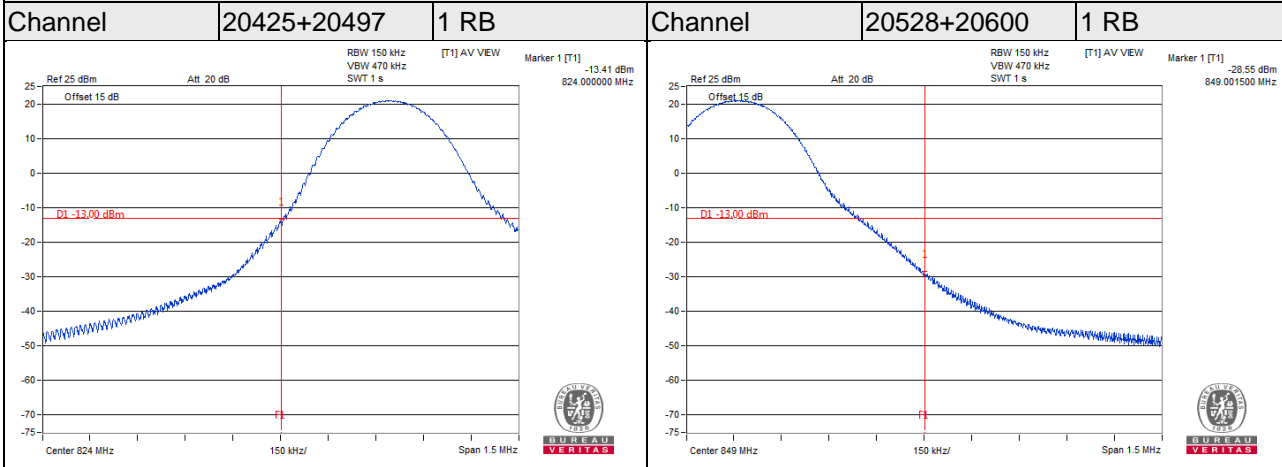

Channel Bandwidth 5+10MHz

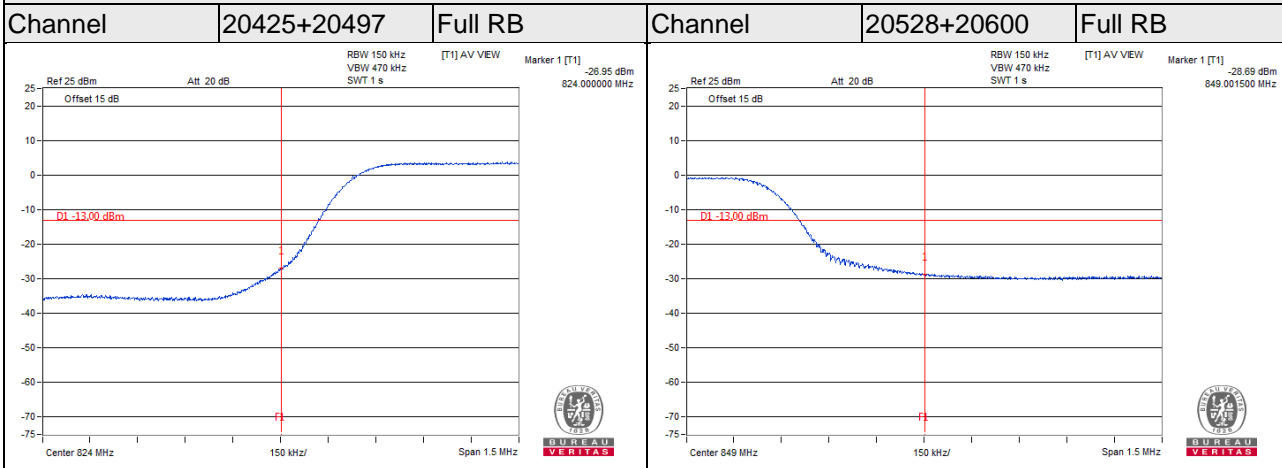

LTE Band 26

Channel Bandwidth 1.4MHz

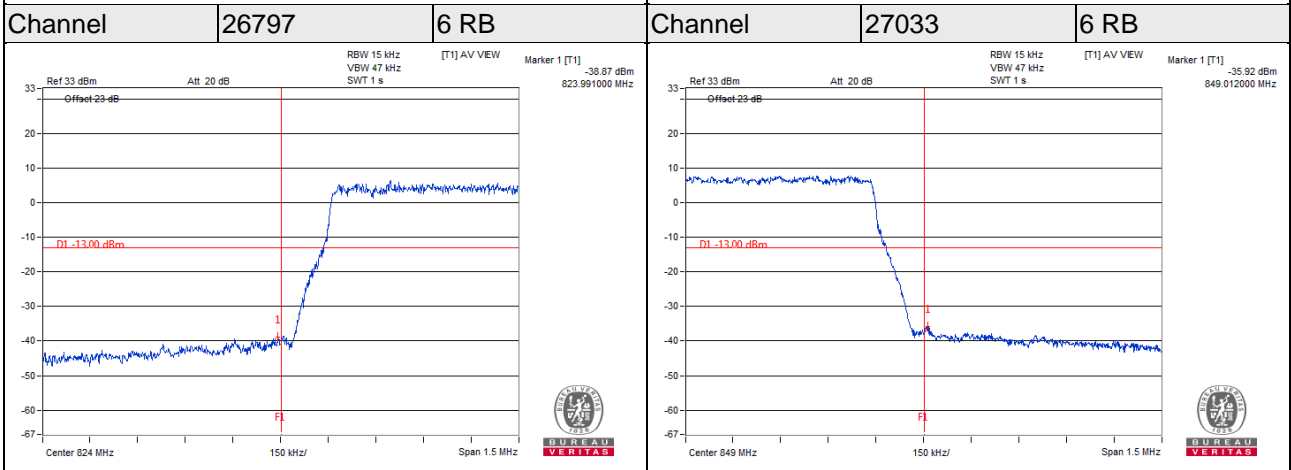
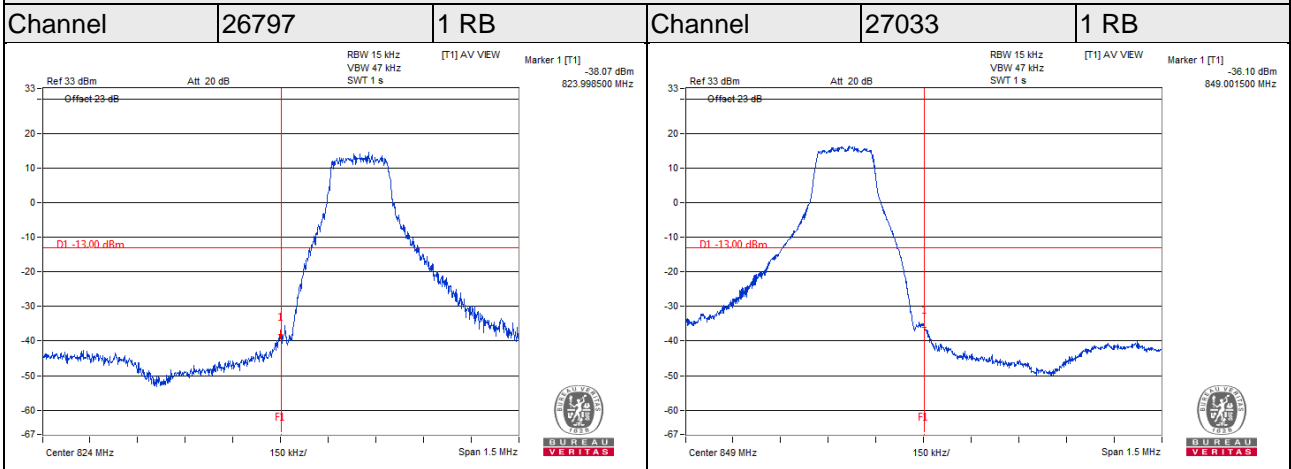

LTE Band 26

Channel Bandwidth 3MHz

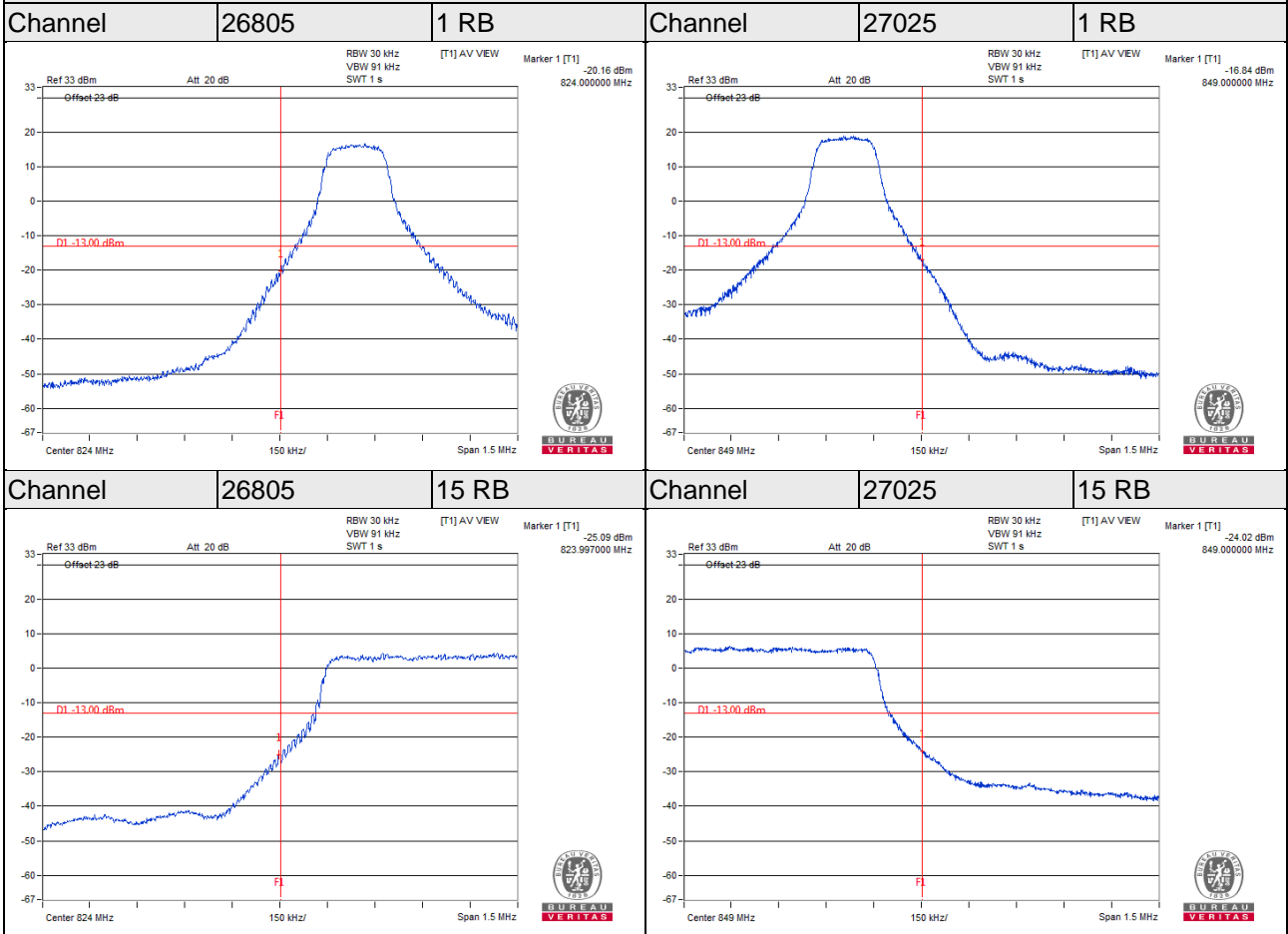

LTE Band 26

Channel Bandwidth 5MHz

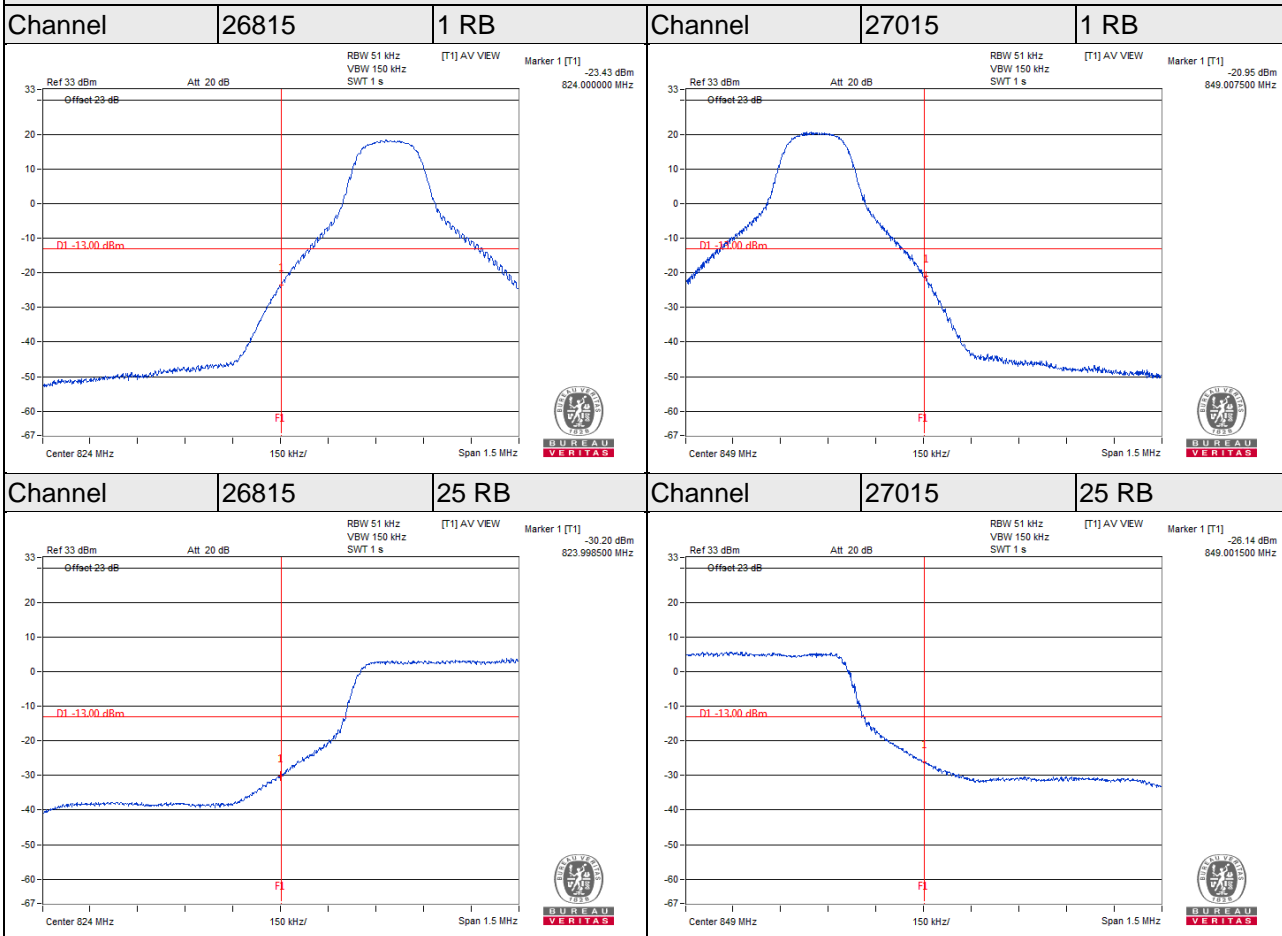

LTE Band 26

Channel Bandwidth 10MHz

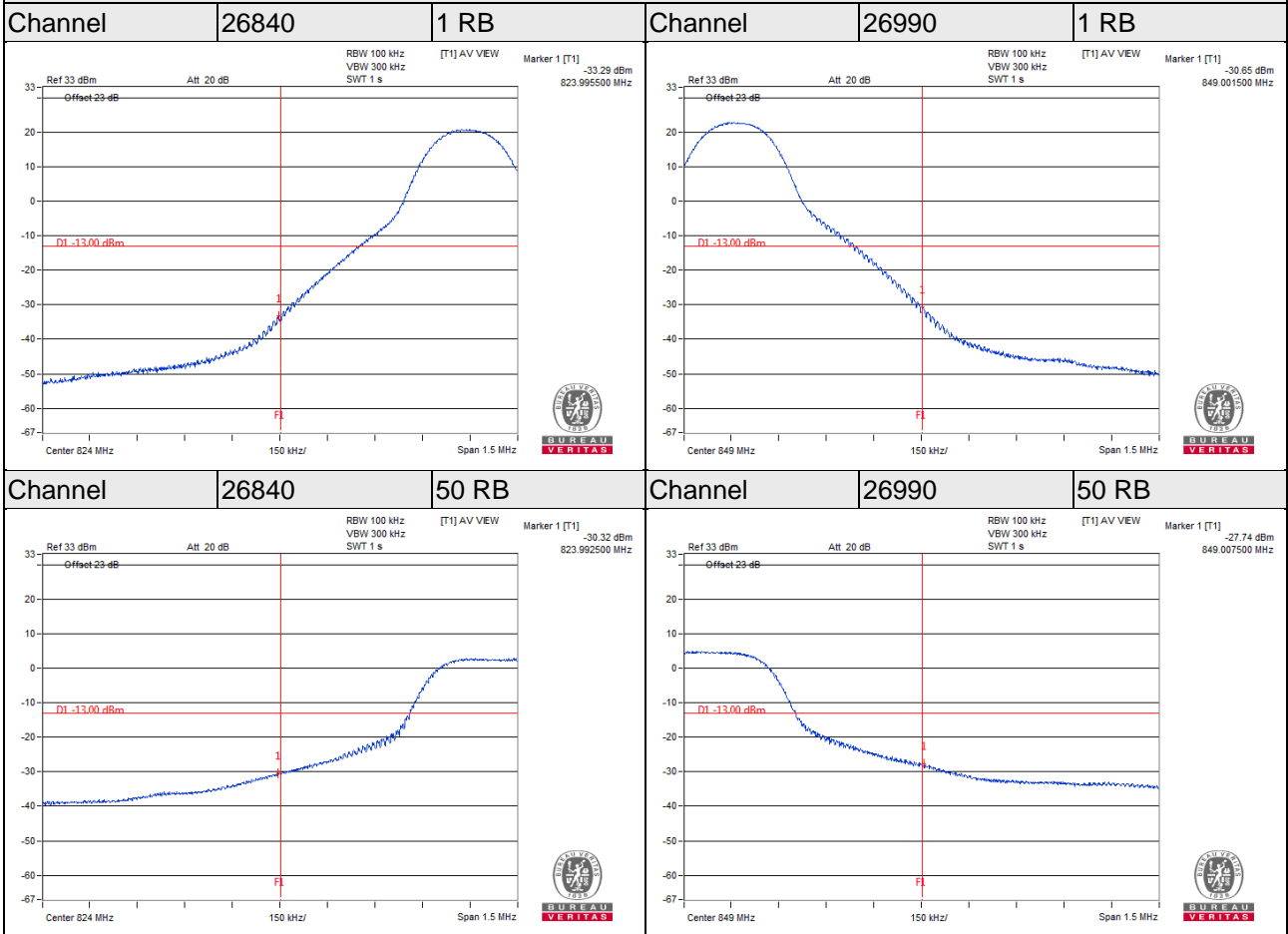

LTE Band 26

Channel Bandwidth 15MHz

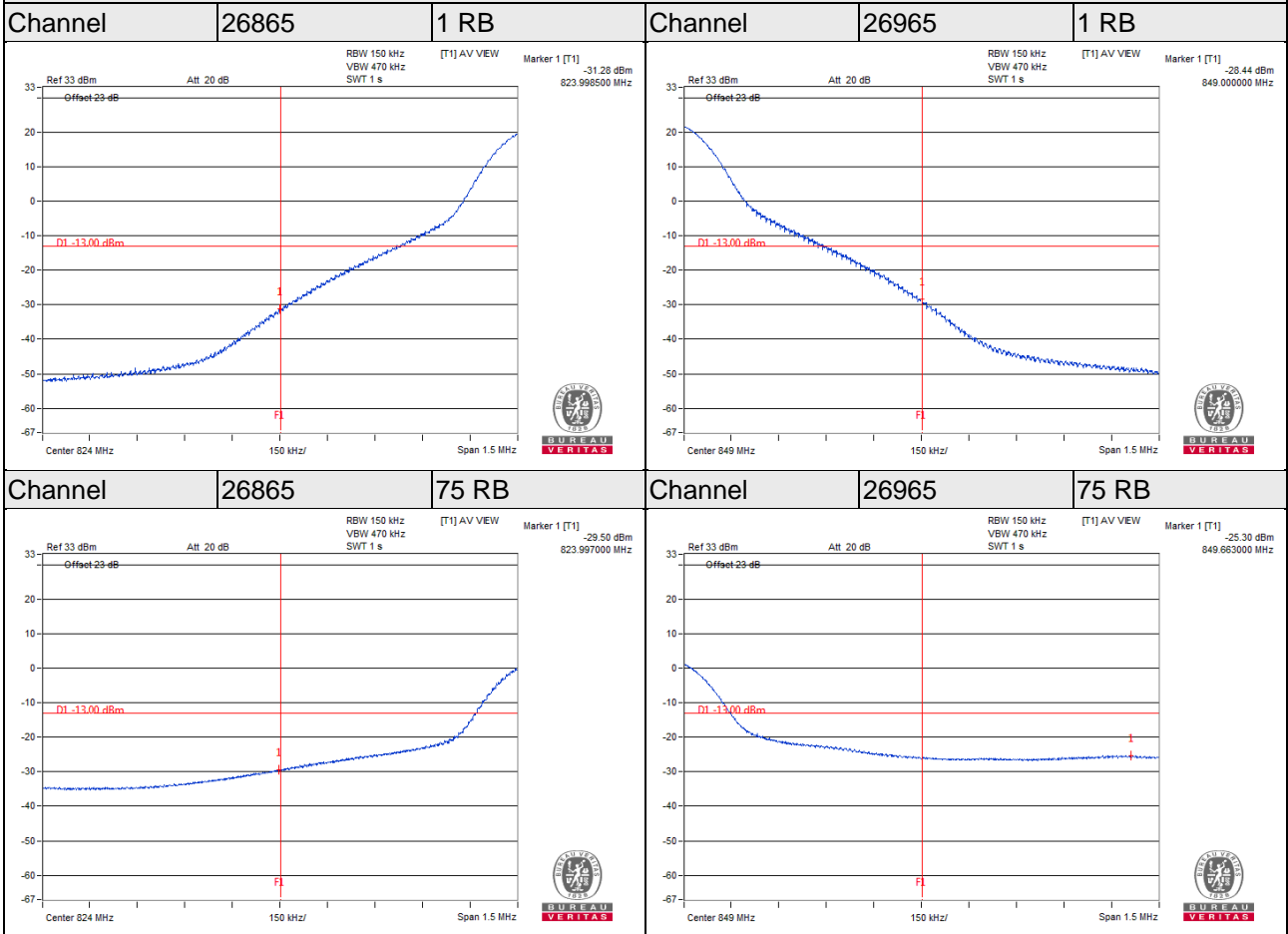

4.6 Peak to Average Ratio

4.5.1 Limits of Peak to Average Ratio Measurement

In measuring transmissions in this band using an average power technique, the peak to-average ratio (PAR) of the transmission may not exceed 13 dB

4.5.2 Test Setup

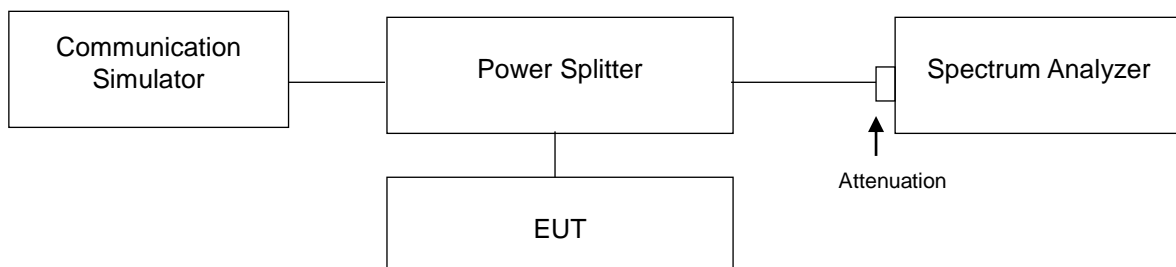

4.5.3 Test Procedures

1. Set resolution measurement bandwidth \geq signal's occupied bandwidth;
2. Set the number of counts to a value that stabilizes the measured CCDF curve;
3. Record the maximum PAPR level associated with a probability of 0.1%.

4.5.4 Test Results

Channel	Freq. (MHz)	Peak to Average Ratio (dB)
		WCDMA
4132	826.4	3.74
4183	836.4	3.82
4233	846.6	3.78

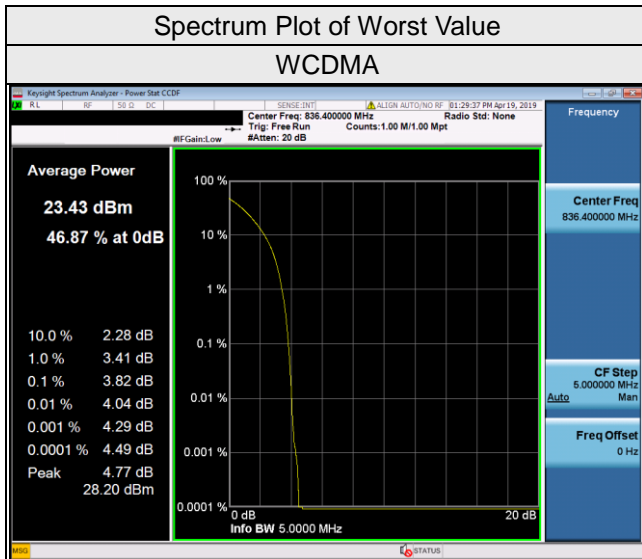

LTE Band 5									
Channel Bandwidth 1.4MHz					Channel Bandwidth 3MHz				
Channel	Frequency (MHz)	Peak To Average Ratio (dB)			Channel	Frequency (MHz)	Peak To Average Ratio (dB)		
		QPSK	16QAM	64QAM			QPSK	16QAM	64QAM
20407	824.7	4.92	6.16	6.70	20415	825.5	4.62	6.06	6.69
20525	836.5	4.98	6.16	6.70	20525	836.5	4.65	6.07	6.72
20643	848.3	4.93	6.15	6.67	20635	847.5	4.64	6.08	6.75
Channel Bandwidth 5MHz					Channel Bandwidth 10MHz				
Channel	Frequency (MHz)	Peak To Average Ratio (dB)			Channel	Frequency (MHz)	Peak To Average Ratio (dB)		
		QPSK	16QAM	64QAM			QPSK	16QAM	64QAM
20425	826.5	4.81	6.07	6.60	20450	829	4.79	6.05	6.57
20525	836.5	4.87	6.09	6.64	20525	836.5	4.83	6.03	6.62
20625	846.5	4.81	6.07	6.64	20600	844	4.82	6.13	6.58

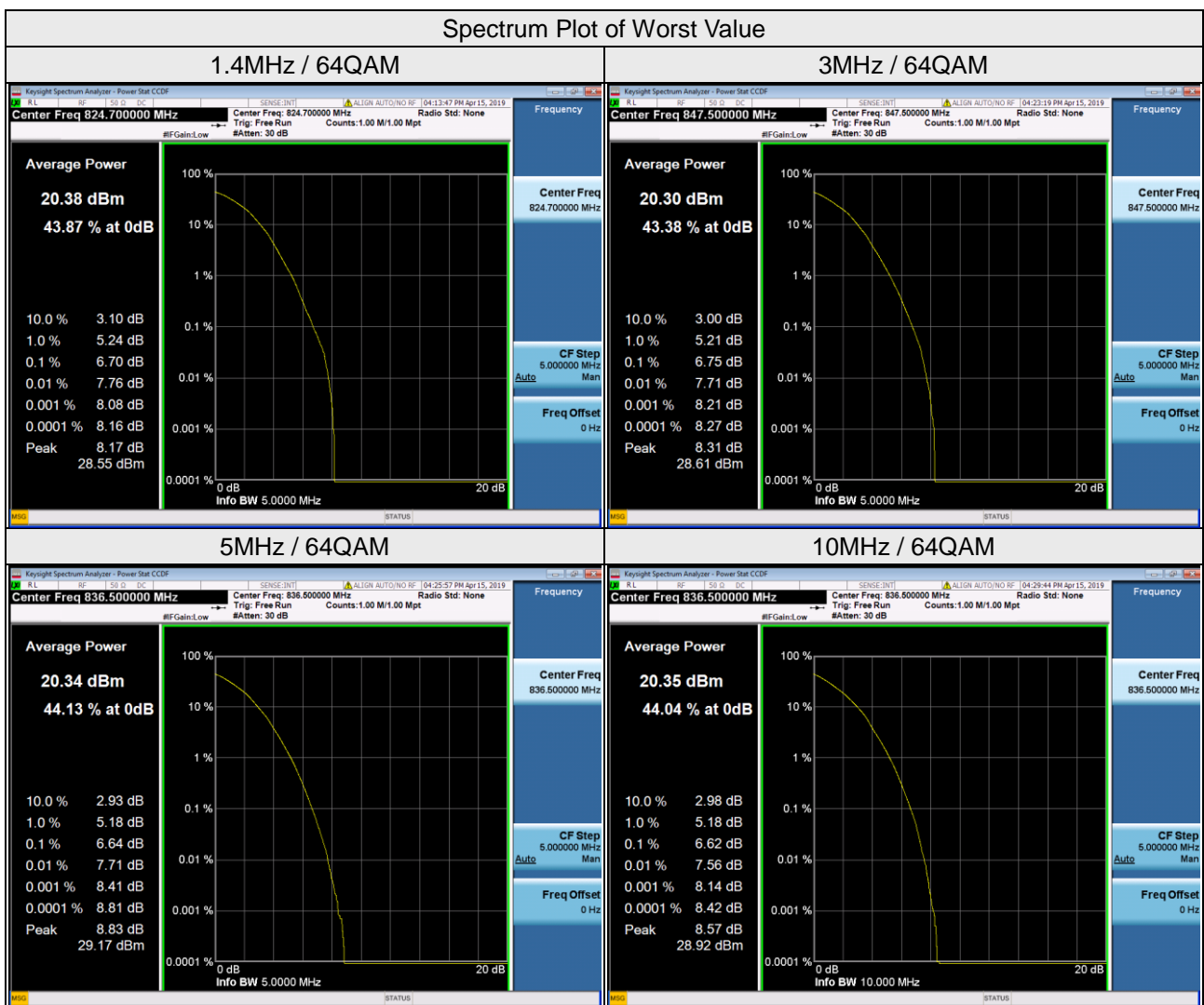

LTE CA_5C

Channel	Freq. (MHz)	Peak to Average Ratio (dB)		
		Peak	Average	Difference
20528+20600	836.8+844	12.05	3.31	8.74

Spectrum Plot of Worst Value

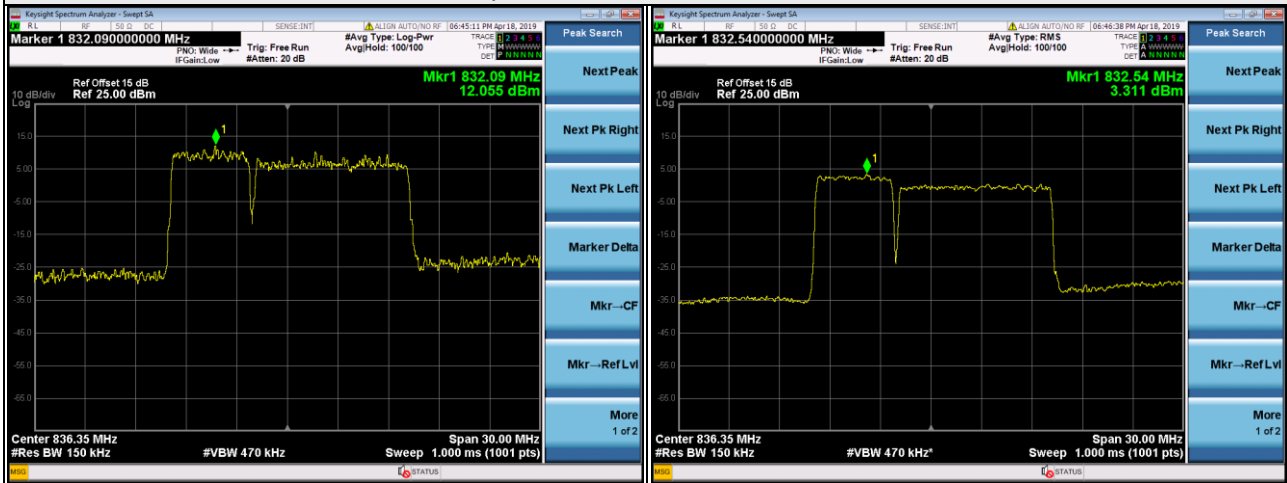

LTE Band 26									
Channel Bandwidth 1.4MHz					Channel Bandwidth 3MHz				
Channel	Frequency (MHz)	Peak To Average Ratio (dB)			Channel	Frequency (MHz)	Peak To Average Ratio (dB)		
		QPSK	16QAM	64QAM			QPSK	16QAM	64QAM
26797	824.7	4.95	6.13	6.68	26805	825.5	4.66	6.08	6.69
26915	836.5	4.96	6.16	6.72	26915	836.5	4.66	6.10	6.73
27033	848.3	4.97	6.15	6.69	27025	847.5	4.67	6.11	6.73
Channel Bandwidth 5MHz					Channel Bandwidth 10MHz				
Channel	Frequency (MHz)	Peak To Average Ratio (dB)			Channel	Frequency (MHz)	Peak To Average Ratio (dB)		
		QPSK	16QAM	64QAM			QPSK	16QAM	64QAM
26815	826.5	4.84	6.08	6.64	26840	829	4.80	6.07	6.62
26915	836.5	4.84	6.13	6.66	26915	836.5	4.81	6.08	6.63
27015	846.5	4.87	6.12	6.67	26990	844	4.89	6.12	6.61
Channel Bandwidth 15MHz									
Channel	Frequency (MHz)	QPSK							
		QPSK	16QAM	64QAM					
26865	831.5	5.03	6.12	6.75					
26915	836.5	4.96	6.10	6.69					
26965	841.5	4.95	6.10	6.69					

Spectrum Plot of Worst Value

1.4MHz / 64QAM

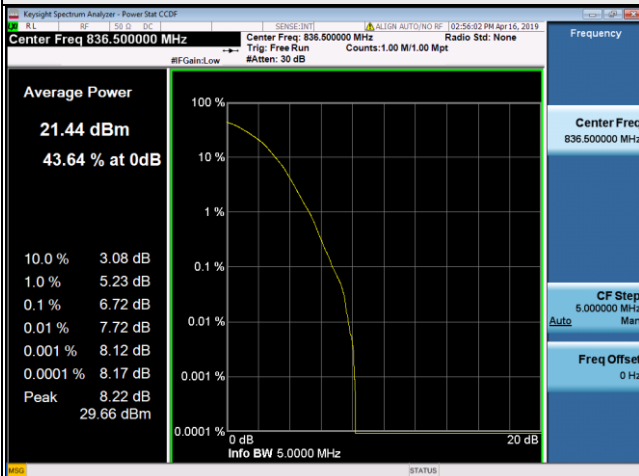

3MHz / 64QAM

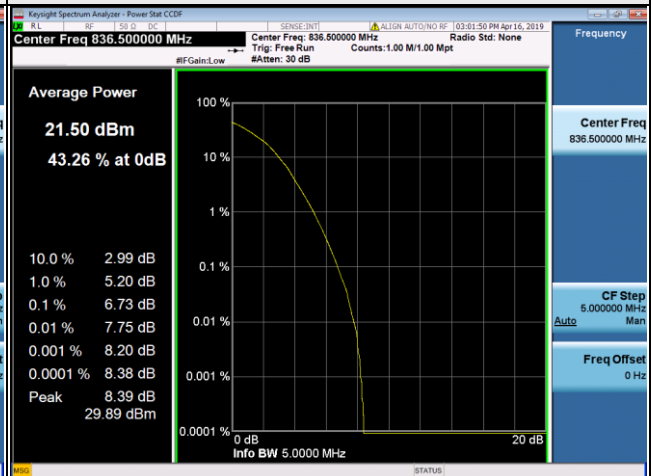

5MHz / 64QAM

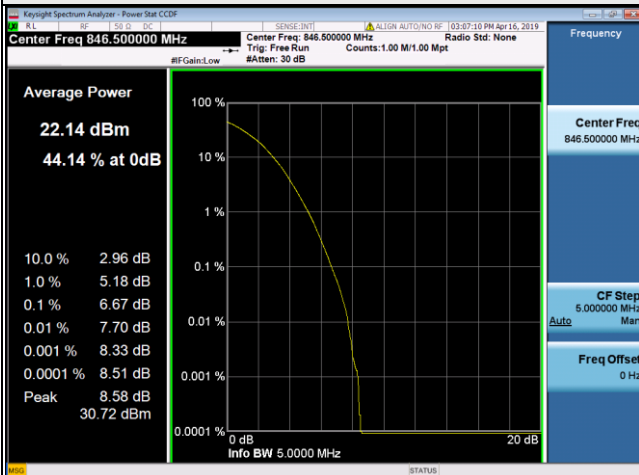

10MHz / 64QAM

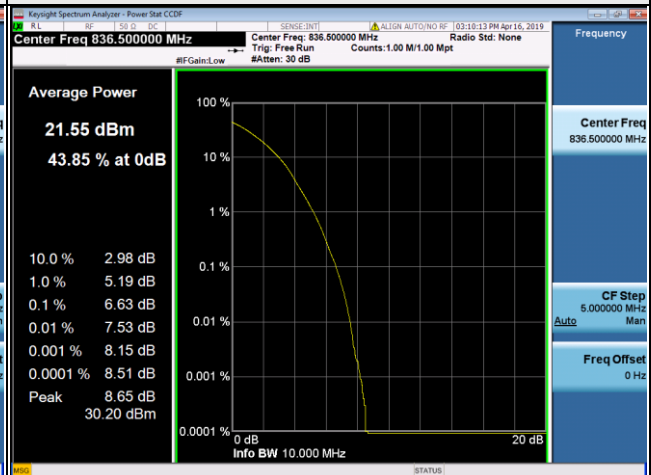

15MHz / 64QAM

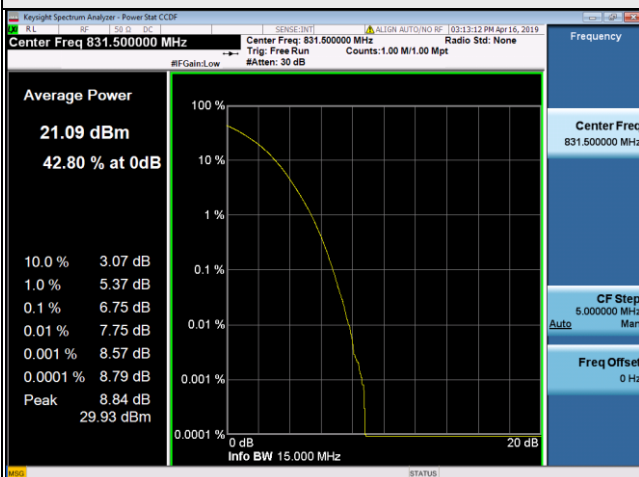

4.7 Conducted Spurious Emissions

4.7.1 Limits of Conducted Spurious Emissions Measurement

The power of any emission outside of the authorized operating frequency ranges must be attenuated below the transmitting power (P) by a factor of at least $43 + 10 \log(P)$ dB. The emission limit equal to -13dBm .

4.7.2 Test Setup

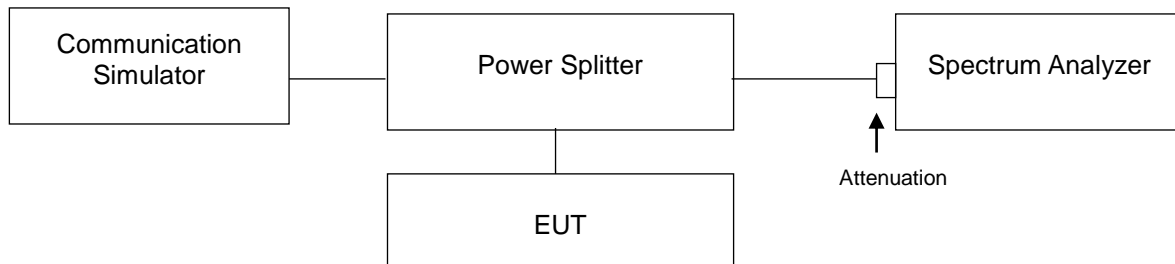

4.7.3 Test Procedure

- a. All measurements were done at 3 channels: low, middle and high operational frequency range.
- b. When the spectrum scanned from 9 kHz to the tenth harmonic of the highest fundamental frequency, it shall be connected to the 20dB pad attenuated the carried frequency.

4.7.4 Test Results

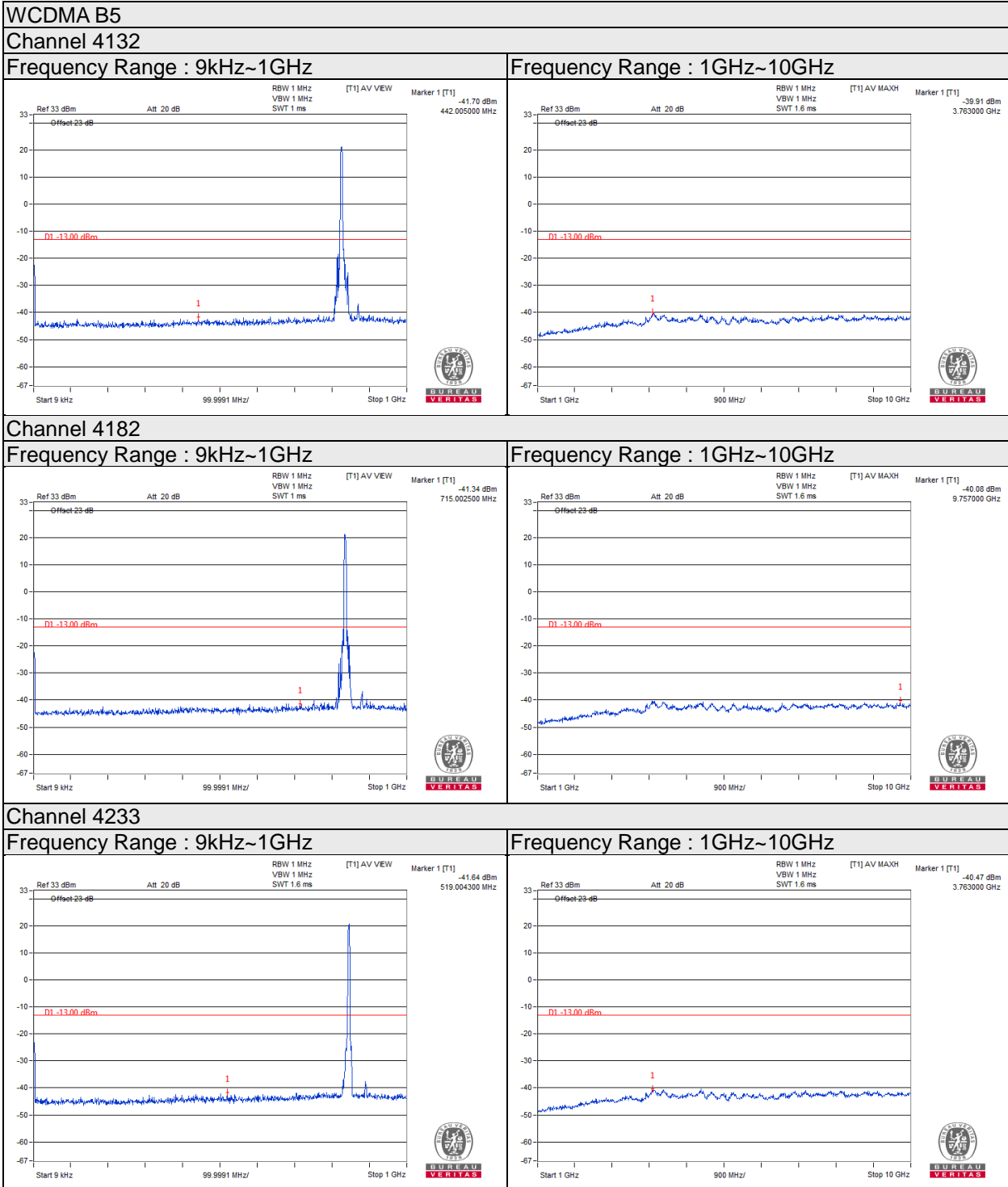

LTE Band 5 Channel Band width: 1.4MHz

Channel 20407

Frequency Range : 9kHz~1GHz

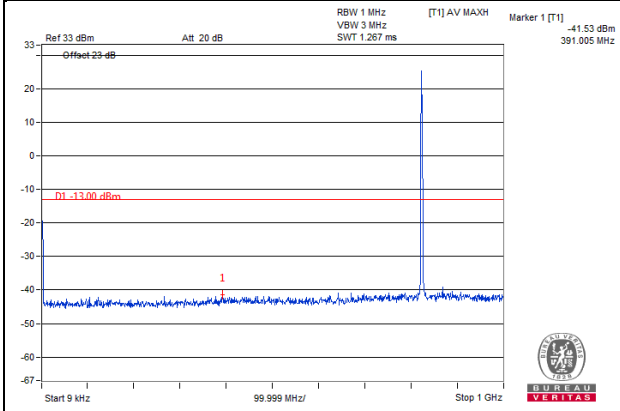

Frequency Range : 1GHz~10GHz

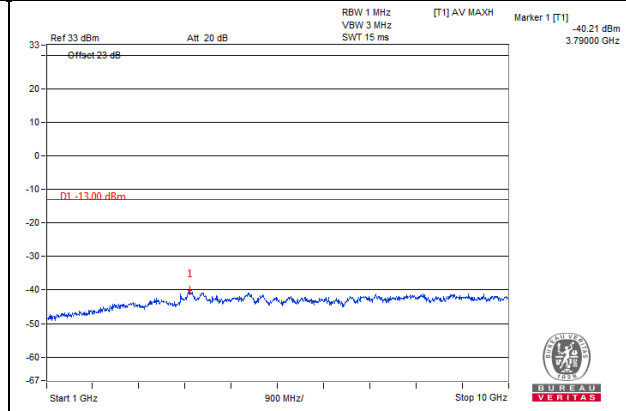

Channel 20525

Frequency Range : 9kHz~1GHz

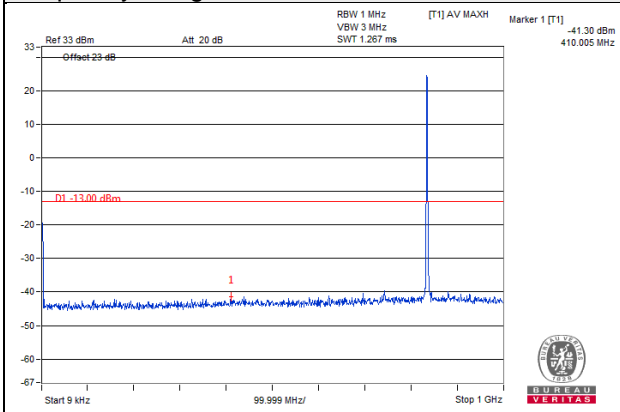

Frequency Range : 1GHz~10GHz

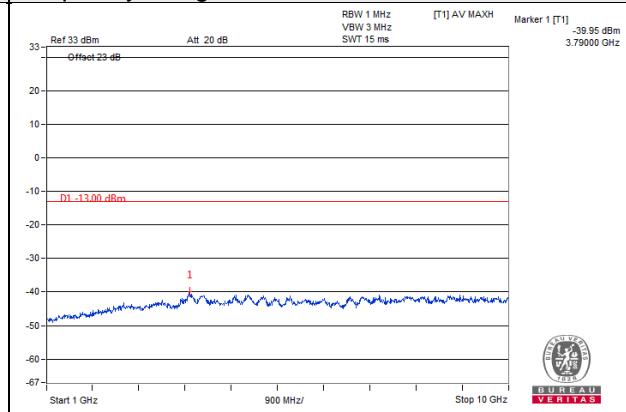

Channel 20643

Frequency Range : 9kHz~1GHz

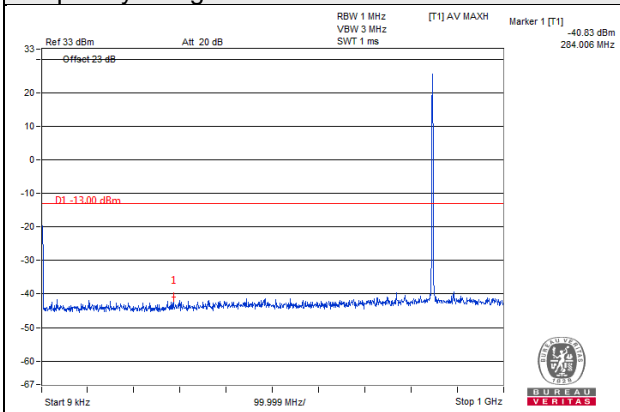

Frequency Range : 1GHz~10GHz

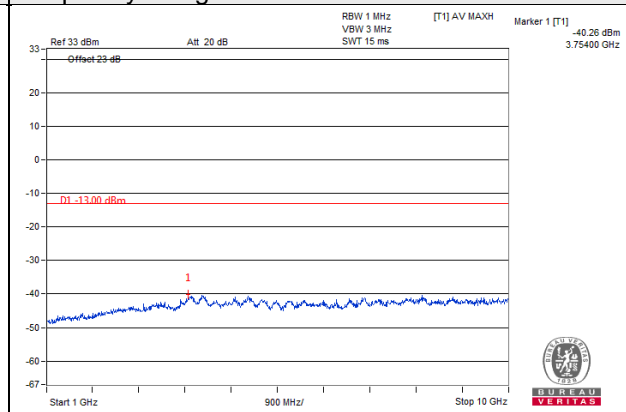

LTE Band 5 Channel Band width: 3MHz

Channel 20415

Frequency Range : 9kHz~1GHz

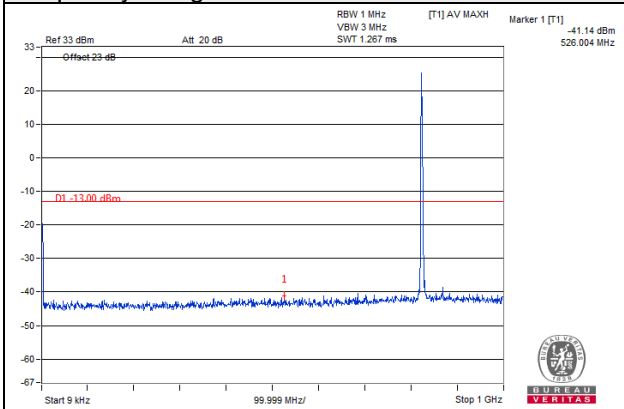

Frequency Range : 1GHz~10GHz

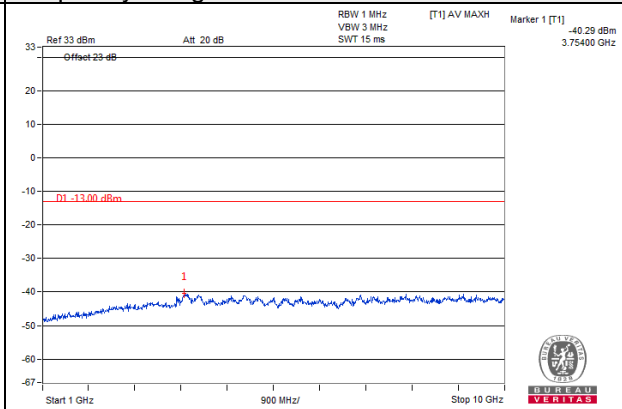

Channel 20525

Frequency Range : 9kHz~1GHz

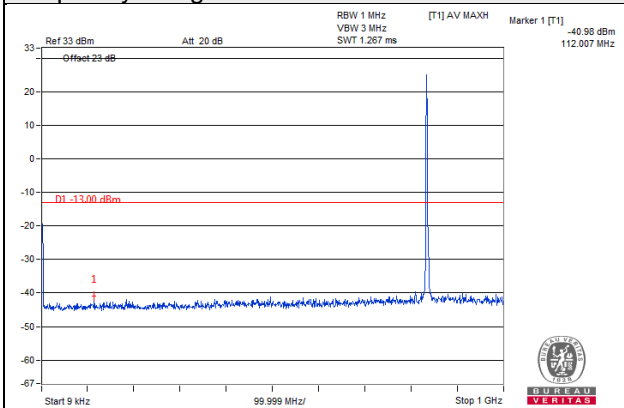

Frequency Range : 1GHz~10GHz

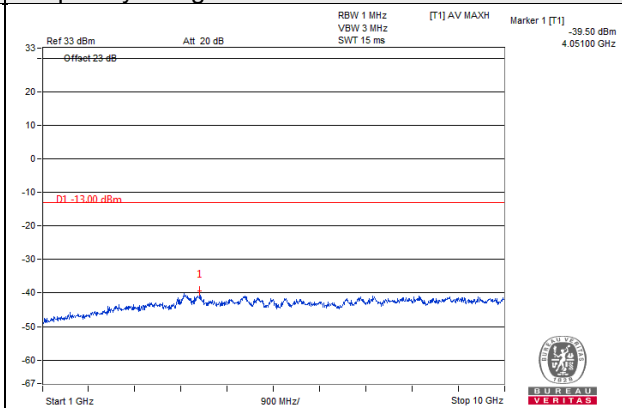

Channel 20635

Frequency Range : 9kHz~1GHz

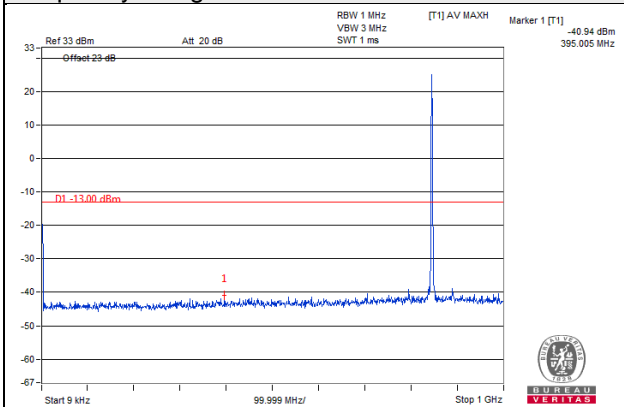

Frequency Range : 1GHz~10GHz

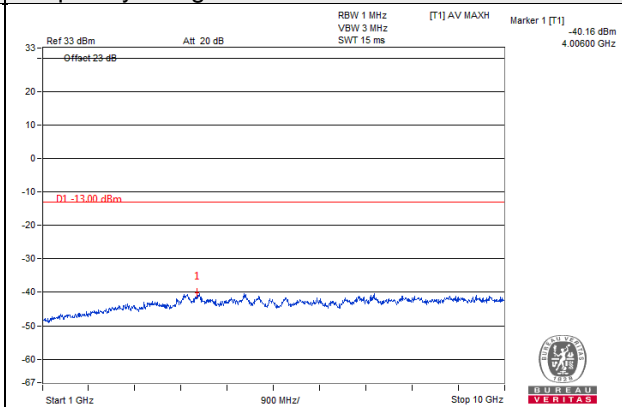

LTE Band 5 Channel Band width: 5MHz

Channel 20425

Frequency Range : 9kHz~1GHz

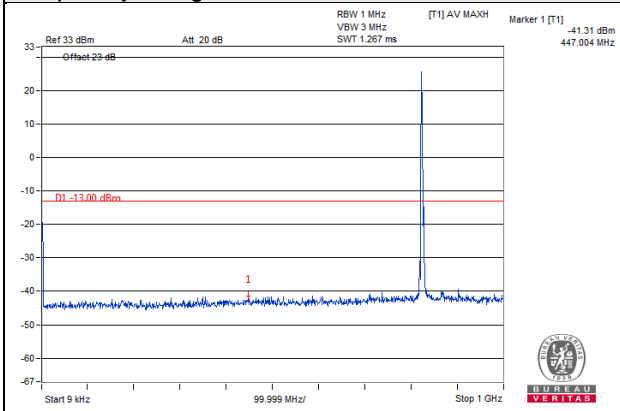

Frequency Range : 1GHz~10GHz

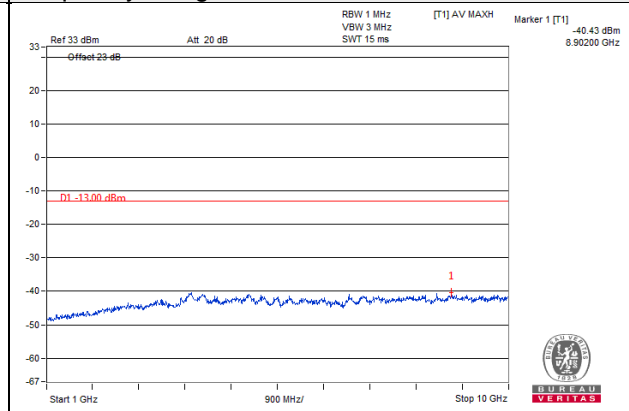

Channel 20525

Frequency Range : 9kHz~1GHz

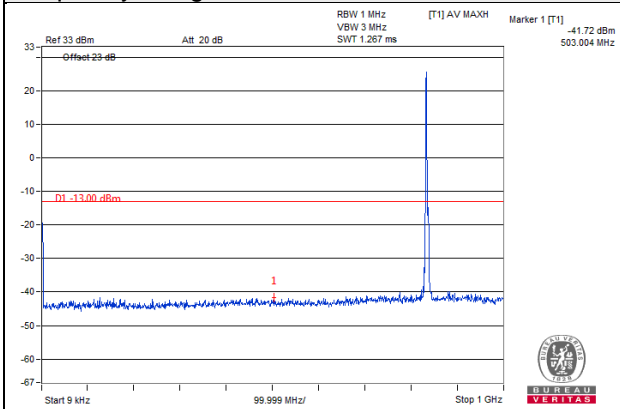

Frequency Range : 1GHz~10GHz

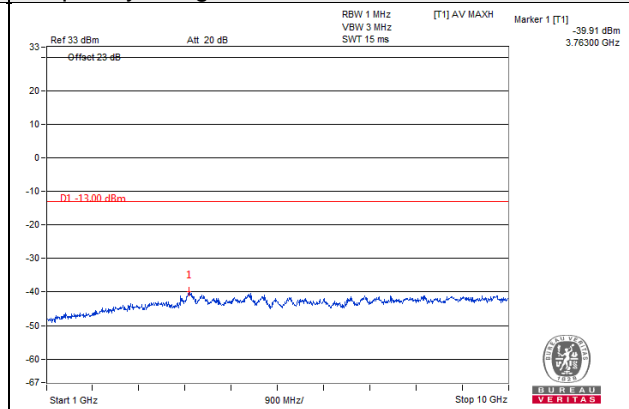

Channel 20625

Frequency Range : 9kHz~1GHz

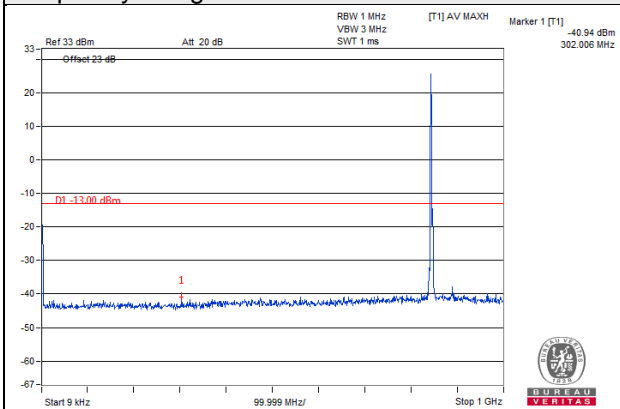

Frequency Range : 1GHz~10GHz

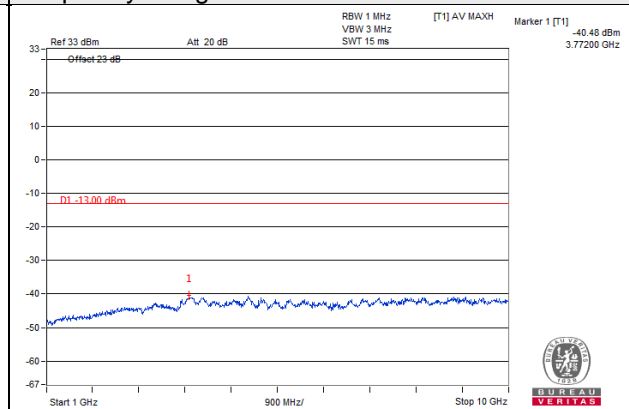

LTE Band 5 Channel Band width: 10MHz

Channel 20450

Frequency Range : 9kHz~1GHz

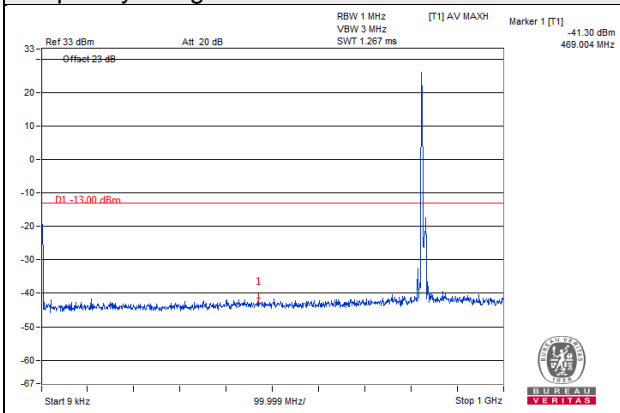

Frequency Range : 1GHz~10GHz

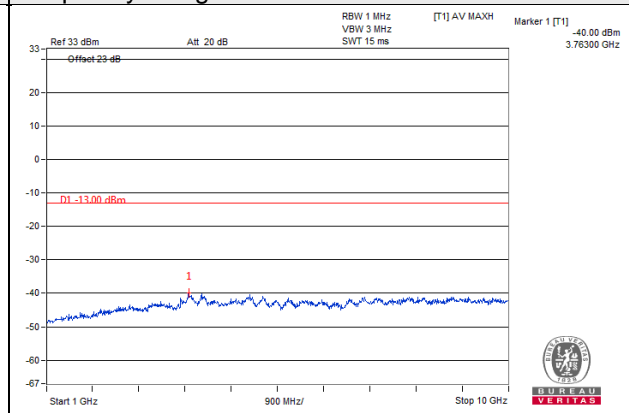

Channel 20525

Frequency Range : 9kHz~1GHz

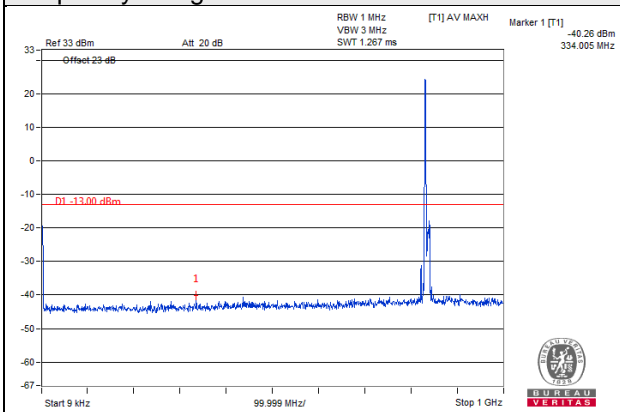

Frequency Range : 1GHz~10GHz

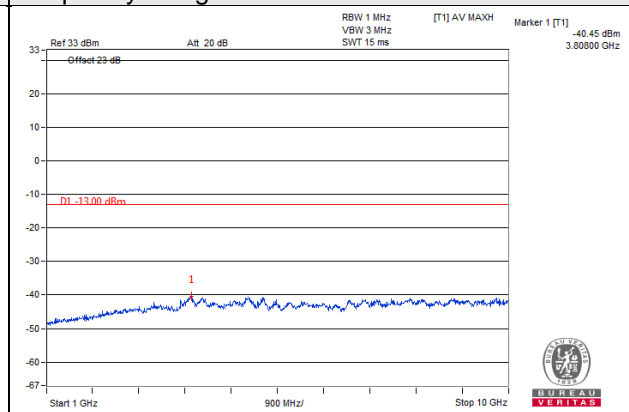

Channel 20600

Frequency Range : 9kHz~1GHz

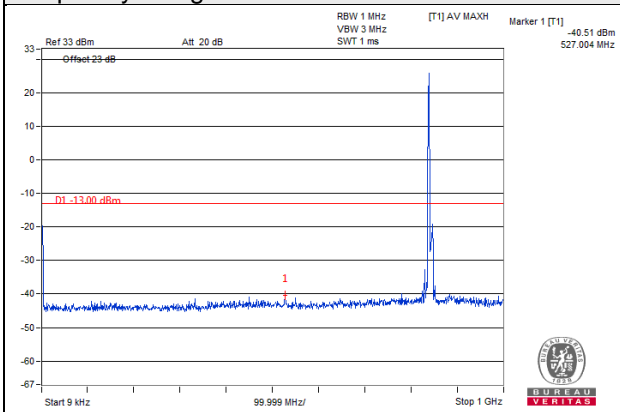

Frequency Range : 1GHz~10GHz

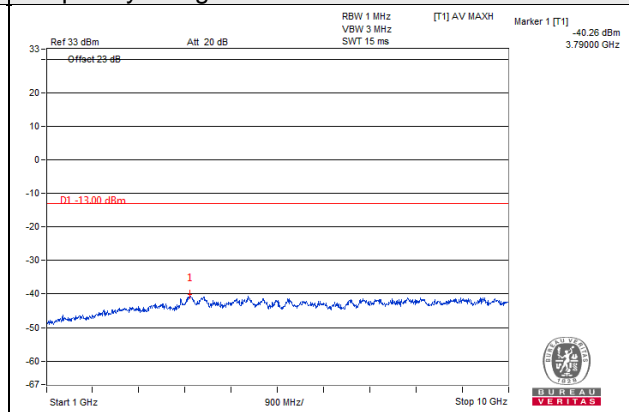

LTE CA_5C Channel Band width: 5+10MHz

Channel 20528+20600

Frequency Range : 9kHz~1GHz

Frequency Range : 1GHz~10GHz

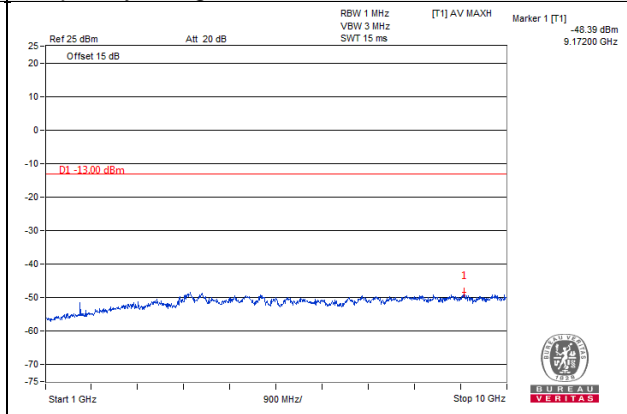
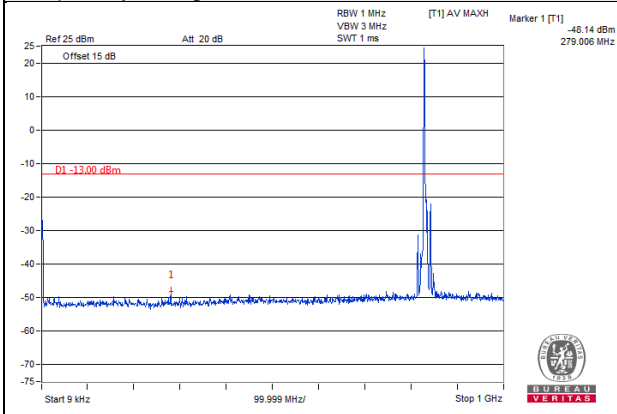

LTE Band 26 Channel Band width: 1.4MHz

Channel 26797

Frequency Range : 9kHz~1GHz

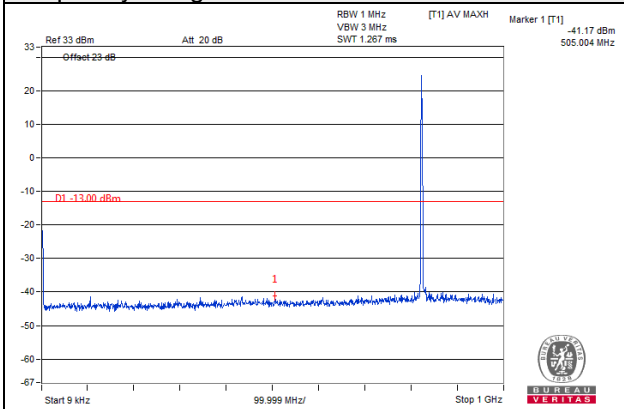

Frequency Range : 1GHz~10GHz

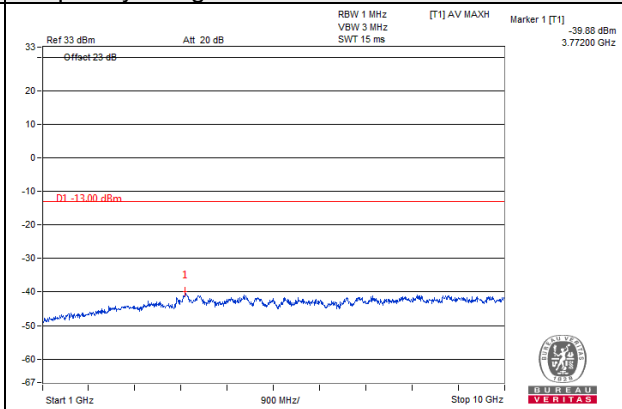

Channel 26915

Frequency Range : 9kHz~1GHz

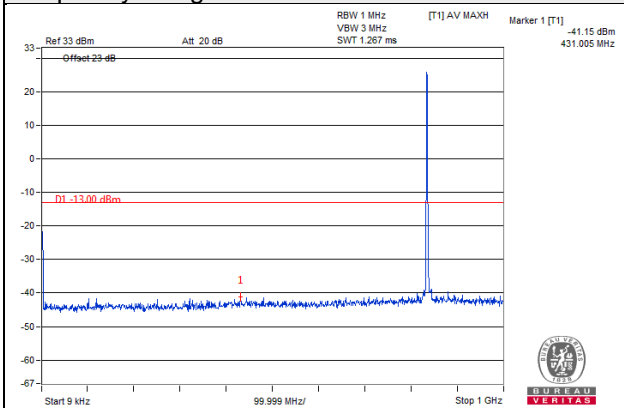

Frequency Range : 1GHz~10GHz

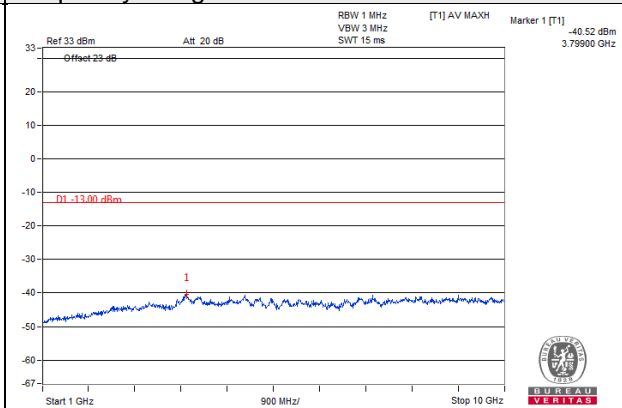

Channel 27033

Frequency Range : 9kHz~1GHz

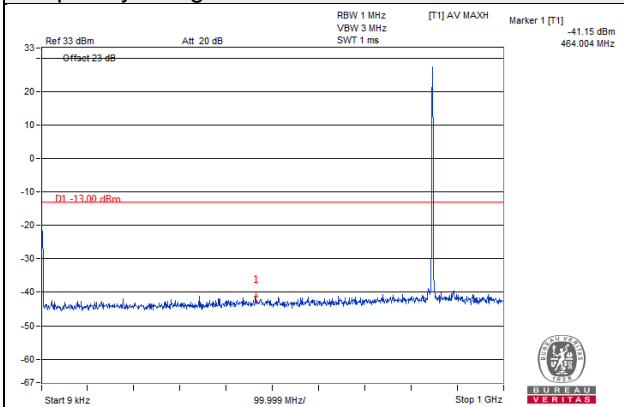

Frequency Range : 1GHz~10GHz

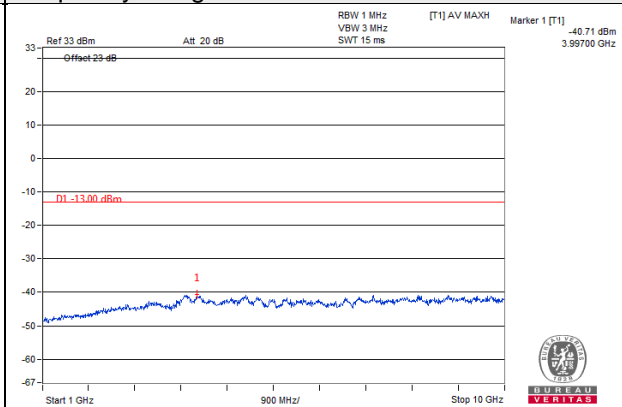

LTE Band 26 Channel Band width: 3MHz

Channel 26805

Frequency Range : 9kHz~1GHz

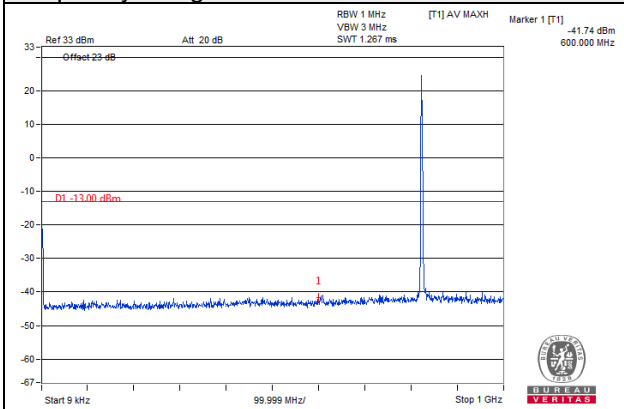

Frequency Range : 1GHz~10GHz

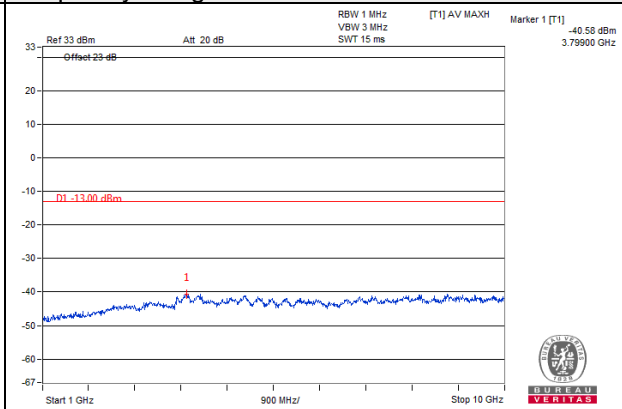

Channel 26915

Frequency Range : 9kHz~1GHz

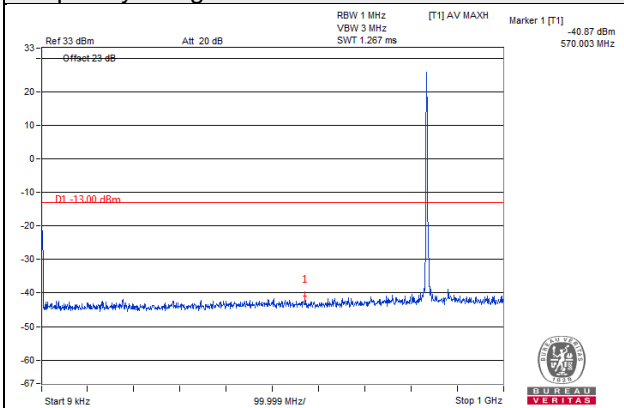

Frequency Range : 1GHz~10GHz

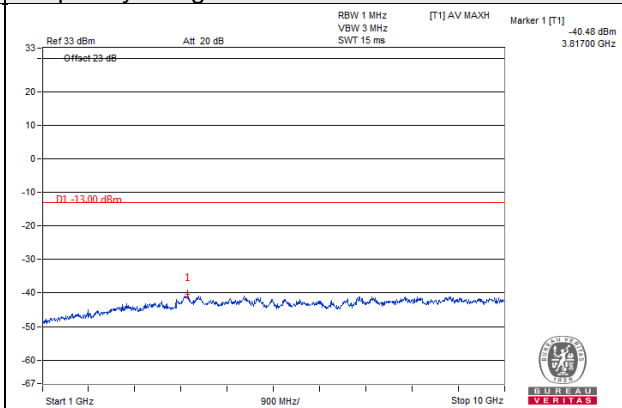

Channel 27025

Frequency Range : 9kHz~1GHz

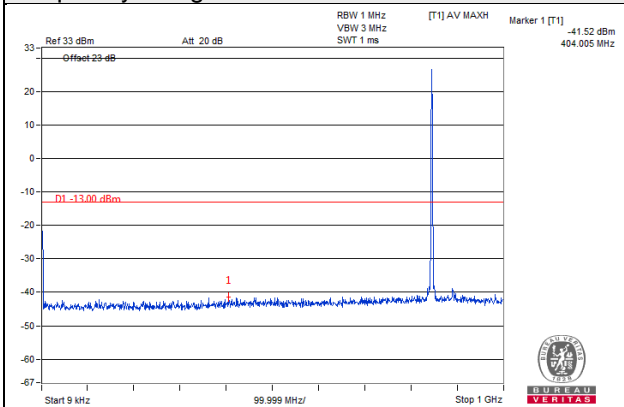

Frequency Range : 1GHz~10GHz

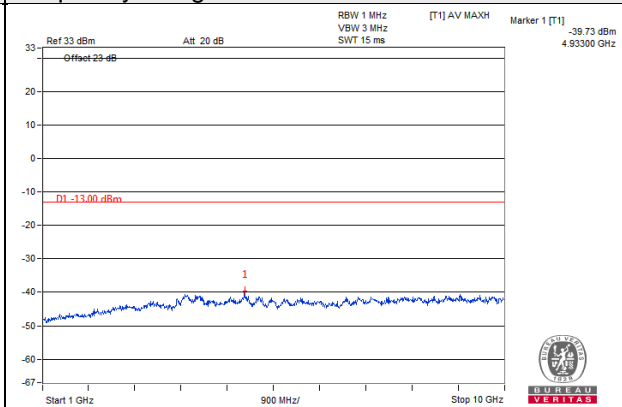

LTE Band 26 Channel Band width: 5MHz

Channel 26815

Frequency Range : 9kHz~1GHz

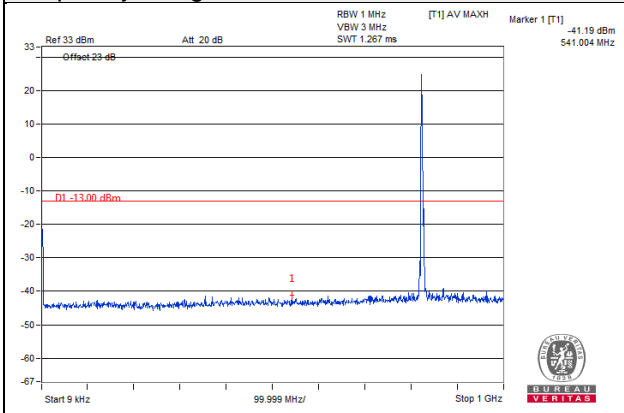

Frequency Range : 1GHz~10GHz

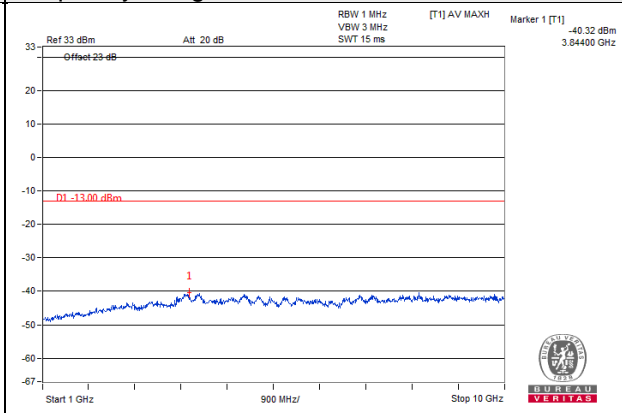

Channel 26915

Frequency Range : 9kHz~1GHz

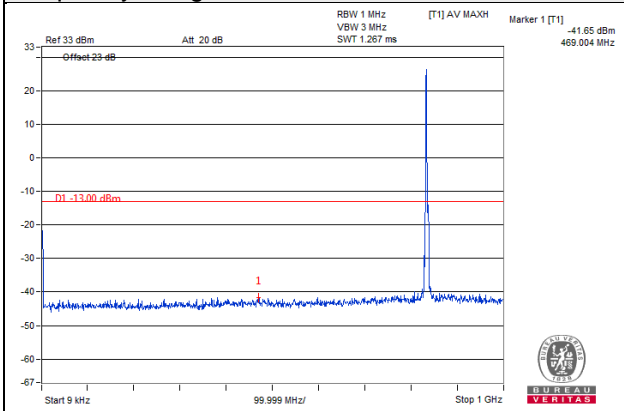

Frequency Range : 1GHz~10GHz

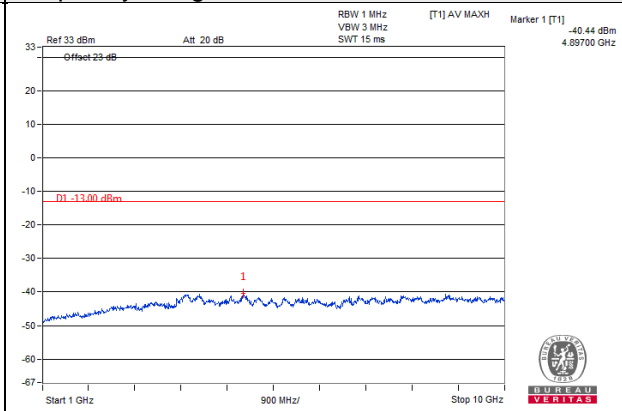

Channel 27015

Frequency Range : 9kHz~1GHz

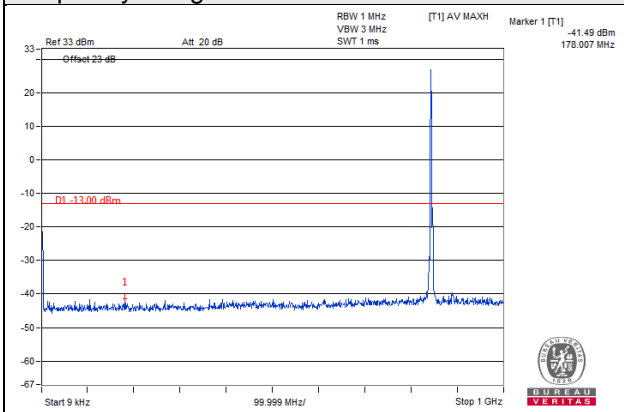

Frequency Range : 1GHz~10GHz

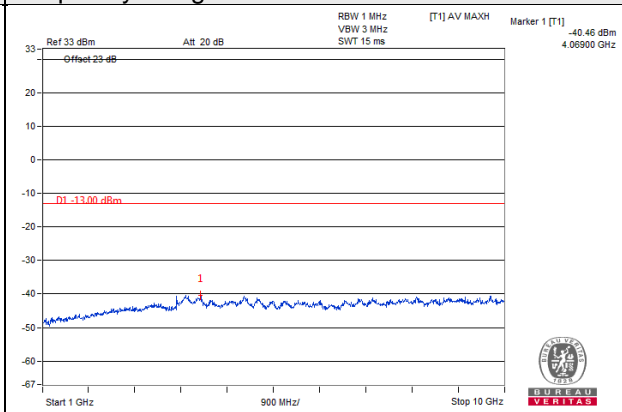

LTE Band 26 Channel Band width: 10MHz

Channel 26840

Frequency Range : 9kHz~1GHz

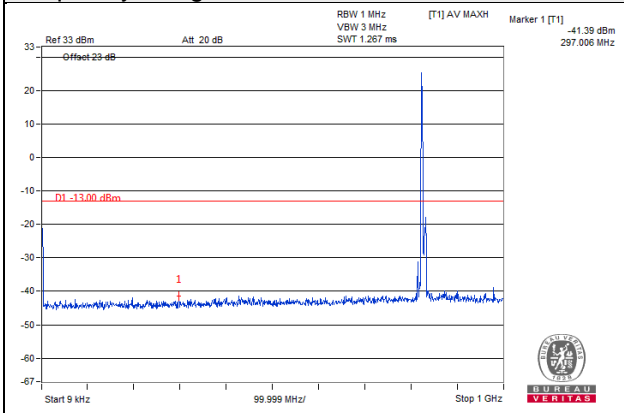

Frequency Range : 1GHz~10GHz

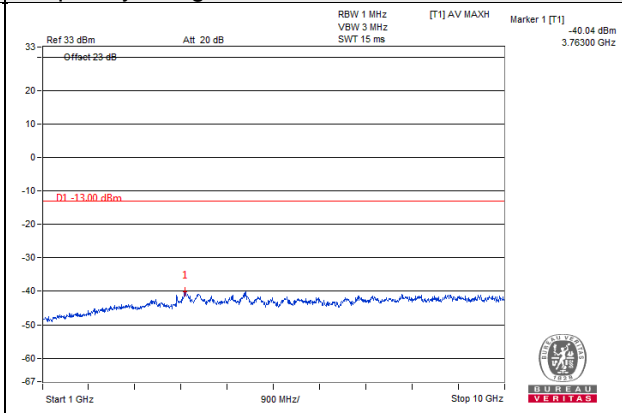

Channel 26915

Frequency Range : 9kHz~1GHz

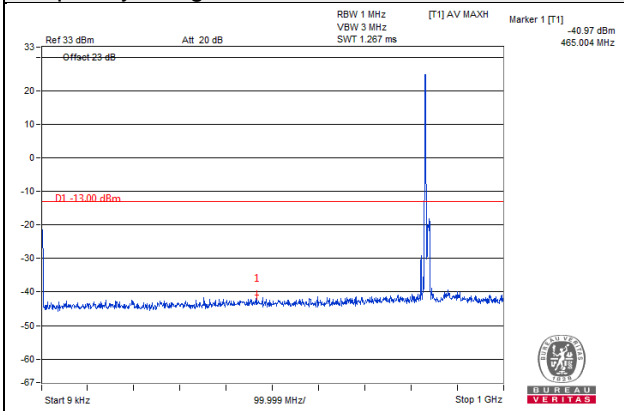

Frequency Range : 1GHz~10GHz

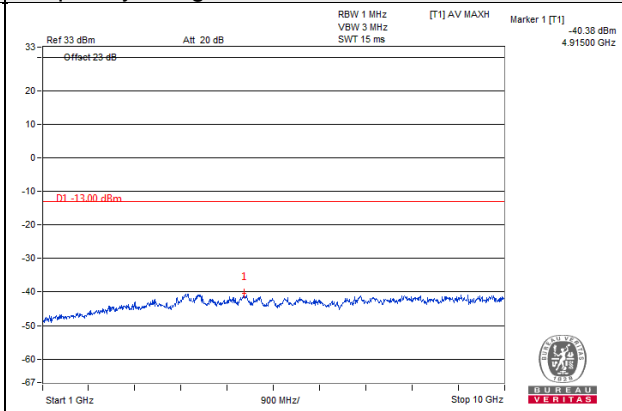

Channel 26990

Frequency Range : 9kHz~1GHz

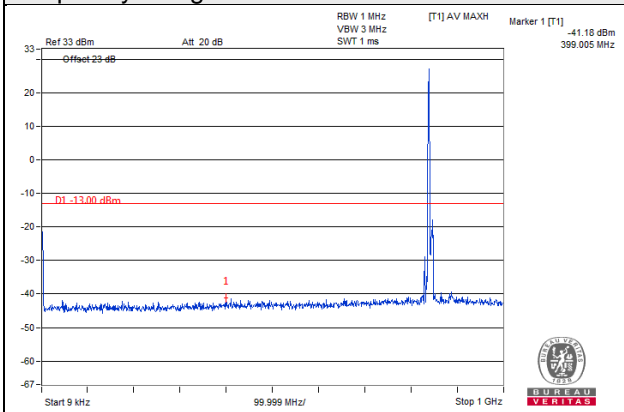

Frequency Range : 1GHz~10GHz

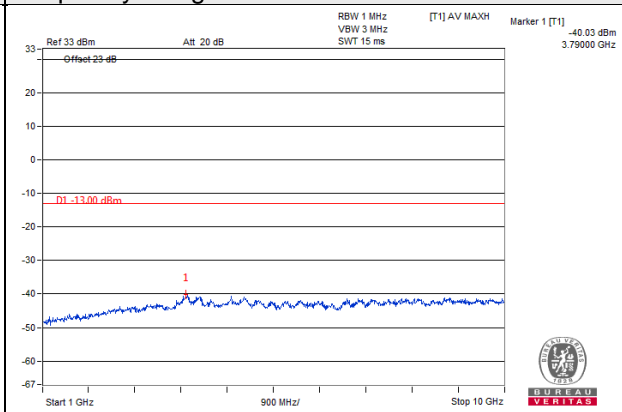

LTE Band 26 Channel Band width: 15MHz

Channel 26865

Frequency Range : 9kHz~1GHz

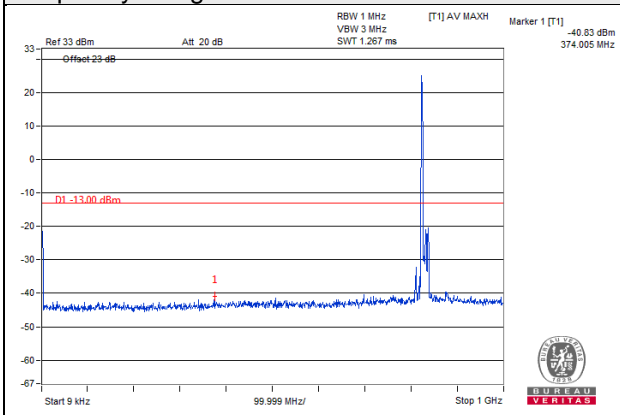

Frequency Range : 1GHz~10GHz

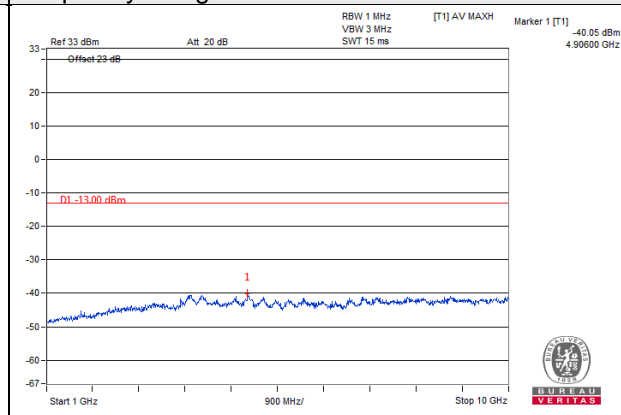

Channel 26915

Frequency Range : 9kHz~1GHz

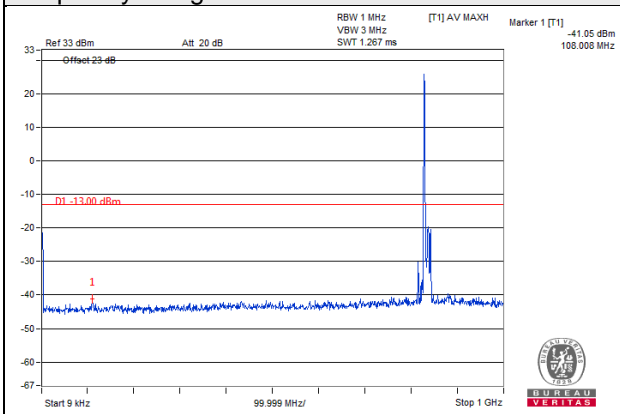

Frequency Range : 1GHz~10GHz

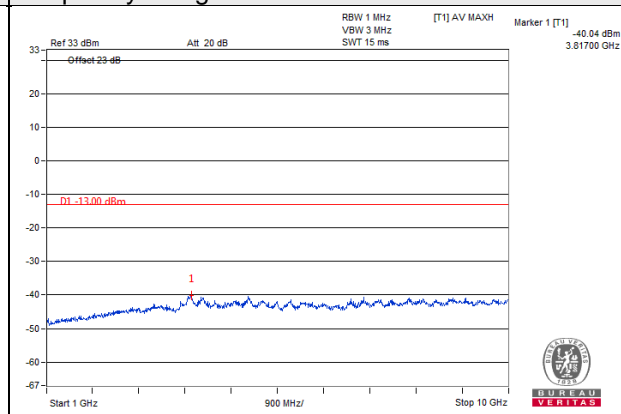

Channel 26965

Frequency Range : 9kHz~1GHz

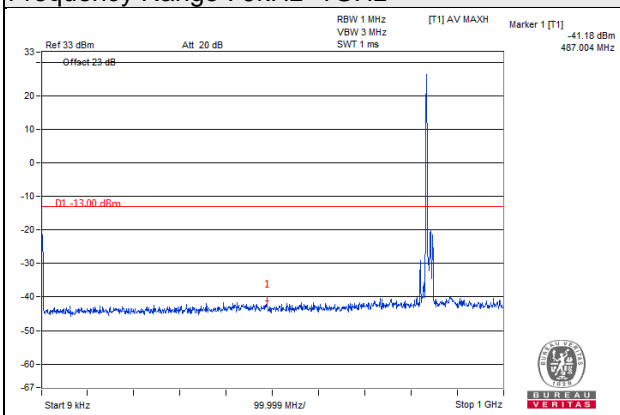

Frequency Range : 1GHz~10GHz

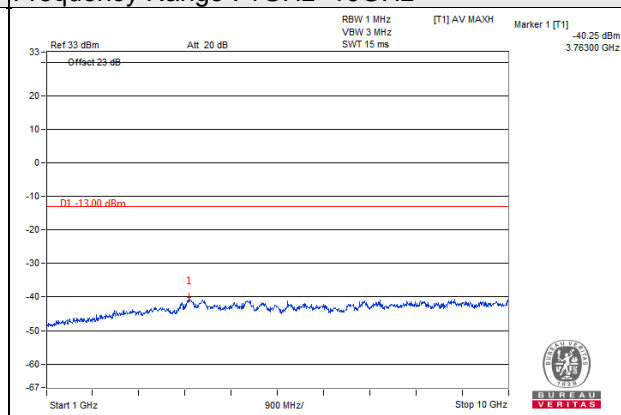

4.8 Radiated Emission Measurement

4.8.1 Limits of Radiated Emission Measurement

The power of any emission outside of the authorized operating frequency ranges must be attenuated below the transmitting power (P) by a factor of at least $43 + 10 \log(P)$ dB. The emission limit equal to -13dBm .

4.8.2 Test Procedure

- a. The power was measured with Spectrum Analyzer.
- b. Substitution method is used for EIRP measurement. In the semi-anechoic chamber, EUT placed on the 0.8m/1.5m height of Turn Table, rotated the table around 360 degrees to search the maximum radiation power and receiver antenna shall be rotated vertical and horizontal polarization and moved height from 1m to 4m to find the maximum polar radiated power. The "Read Value" is the spectrum reading the maximum power value.
- c. Follow ANSI 63.26 section 5.2.7 d), $\text{EIRP Value (dBm)} = \text{Read Value (dB}\mu\text{V/m)} - \text{Correction Factor @ 3m}$
- d. $\text{Correction Factor (dB) @ 3M} = 20\log(D) - 104.8$; where D is the measurement distance @3m $= -95.26\text{dB}$
- e. ERP power can be calculated form EIRP power by subtracting the gain of dipole, $\text{ERP power} = \text{EIRP power} - 2.15\text{dBi}$.

NOTE: The resolution bandwidth and video bandwidth of test receiver/spectrum analyzer is 1MHz/3MHz.

4.8.3 Deviation from Test Standard

No deviation.

**4.8.4 Test Setup
For Below 1GHz**

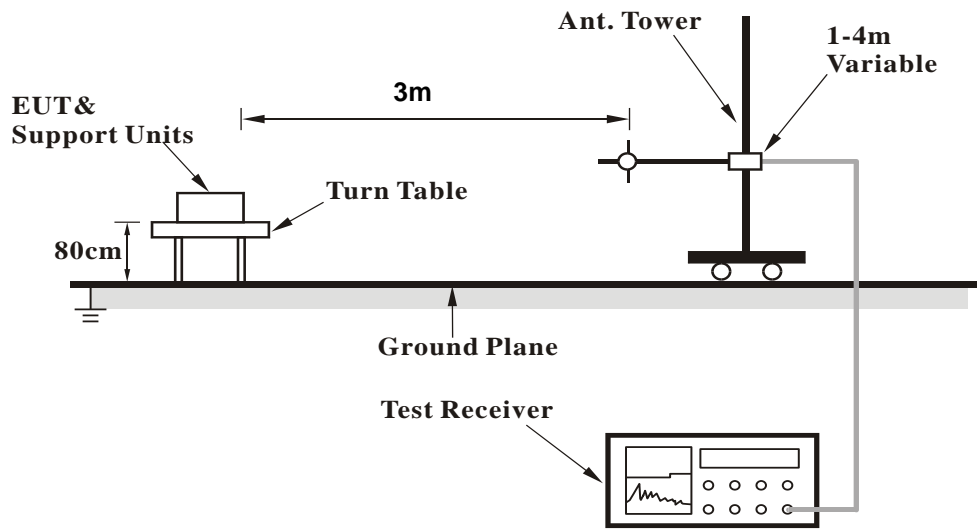

For Above 1GHz:

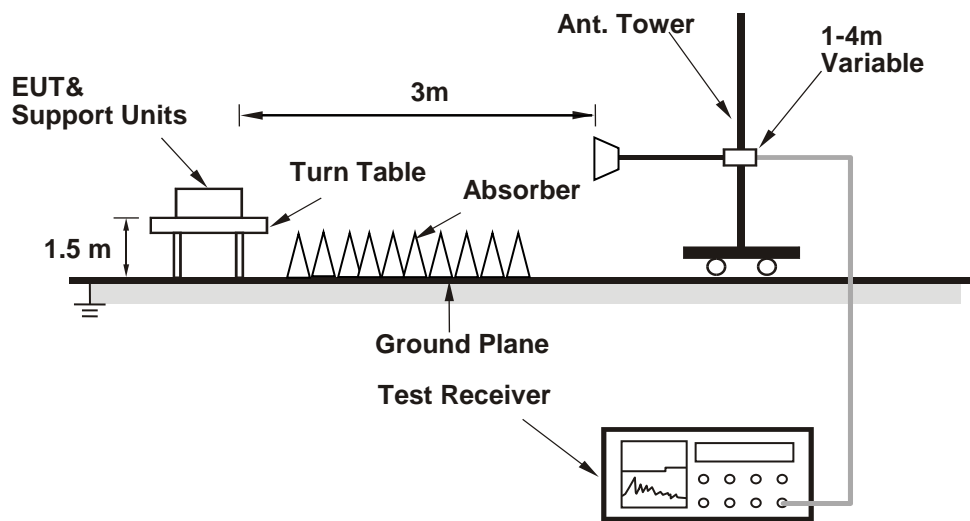

For the actual test configuration, please refer to the attached file (Test Setup Photo).

4.8.5 Test Results

BELOW 1GHz

WCDMA:

Mode	TX channel 4132	Frequency Range	Below 1000 MHz
------	-----------------	-----------------	----------------

Antenna Polarity & Test Distance: Horizontal at 3 M

No.	Freq. (MHz)	Reading (dB μ V/m)	Correction Factor (dB)	EIRP (dBm)	Limit (dBm)	Margin (dB)
1	92.07	36.4	-95.26	-58.86	-13	-45.86
2	240.02	39.61	-95.26	-55.65	-13	-42.65
3	288.27	37.34	-95.26	-57.92	-13	-44.92
4	345.92	33.74	-95.26	-61.52	-13	-48.52

Antenna Polarity & Test Distance: Vertical at 3 M

No.	Freq. (MHz)	Reading (dB μ V/m)	Correction Factor (dB)	EIRP (dBm)	Limit (dBm)	Margin (dB)
1	68.13	34.35	-95.26	-60.91	-13	-47.91
2	93.65	36.77	-95.26	-58.49	-13	-45.49
3	130.21	30.98	-95.26	-64.28	-13	-51.28
4	239	35.56	-95.26	-59.70	-13	-46.70

Remarks:

1. Follow ANSI 63.26 section 5.2.7 d), EIRP Value (dBm) = E (dB μ V/m) - Correction Factor @ 3m.
2. Correction Factor (dB) = 20log(D) - 104.8; where D is the measurement distance @3m.

Mode	TX channel 4182	Frequency Range	Below 1000 MHz
------	-----------------	-----------------	----------------

Antenna Polarity & Test Distance: Horizontal at 3 M

No.	Freq. (MHz)	Reading (dB μ V/m)	Correction Factor (dB)	EIRP (dBm)	Limit (dBm)	Margin (dB)
1	91.21	36.75	-95.26	-58.51	-13	-45.51
2	236.62	40.22	-95.26	-55.04	-13	-42.04
3	290.87	36.49	-95.26	-58.77	-13	-45.77
4	346.89	35.67	-95.26	-59.59	-13	-46.59

Antenna Polarity & Test Distance: Vertical at 3 M

No.	Freq. (MHz)	Reading (dB μ V/m)	Correction Factor (dB)	EIRP (dBm)	Limit (dBm)	Margin (dB)
1	66.94	35.58	-95.26	-59.68	-13	-46.68
2	95.44	37.55	-95.26	-57.71	-13	-44.71
3	129.9	29.77	-95.26	-65.49	-13	-52.49
4	237.01	35.1	-95.26	-60.16	-13	-47.16

Remarks:

1. Follow ANSI 63.26 section 5.2.7 d), EIRP Value (dBm) = E (dB μ V/m) - Correction Factor @ 3m.
2. Correction Factor (dB) = 20log(D) - 104.8; where D is the measurement distance @3m.

Mode	TX channel 4233	Frequency Range	Below 1000 MHz
------	-----------------	-----------------	----------------

Antenna Polarity & Test Distance: Horizontal at 3 M

No.	Freq. (MHz)	Reading (dB μ V/m)	Correction Factor (dB)	EIRP (dBm)	Limit (dBm)	Margin (dB)
1	90.57	35.98	-95.26	-59.28	-13	-46.28
2	235.69	38.1	-95.26	-57.16	-13	-44.16
3	289.22	37.29	-95.26	-57.97	-13	-44.97
4	345.41	35.47	-95.26	-59.79	-13	-46.79

Antenna Polarity & Test Distance: Vertical at 3 M

No.	Freq. (MHz)	Reading (dB μ V/m)	Correction Factor (dB)	EIRP (dBm)	Limit (dBm)	Margin (dB)
1	69.75	35.33	-95.26	-59.93	-13	-46.93
2	92.96	34.83	-95.26	-60.43	-13	-47.43
3	127.07	29.73	-95.26	-65.53	-13	-52.53
4	236.65	35.64	-95.26	-59.62	-13	-46.62

Remarks:

1. Follow ANSI 63.26 section 5.2.7 d), EIRP Value (dBm) = E (dB μ V/m) - Correction Factor @ 3m.
2. Correction Factor (dB) = 20log(D) - 104.8; where D is the measurement distance @3m.

LTE Band 5: 1.4MHz

Mode	TX channel 20407	Frequency Range	Below 1000 MHz
------	------------------	-----------------	----------------

Antenna Polarity & Test Distance: Horizontal at 3 M

No.	Freq. (MHz)	Reading (dB μ V/m)	Correction Factor (dB)	EIRP (dBm)	Limit (dBm)	Margin (dB)
1	85.47	39.36	-95.26	-55.90	-13	-42.90
2	137.54	37.05	-95.26	-58.21	-13	-45.21
3	289.28	33.97	-95.26	-61.29	-13	-48.29
4	343.93	37.33	-95.26	-57.93	-13	-44.93

Antenna Polarity & Test Distance: Vertical at 3 M

No.	Freq. (MHz)	Reading (dB μ V/m)	Correction Factor (dB)	EIRP (dBm)	Limit (dBm)	Margin (dB)
1	66.11	32.64	-95.26	-62.62	-13	-49.62
2	92.62	29.51	-95.26	-65.75	-13	-52.75
3	129.72	33.31	-95.26	-61.95	-13	-48.95
4	238.56	31.95	-95.26	-63.31	-13	-50.31

Remarks:

1. Follow ANSI 63.26 section 5.2.7 d), EIRP Value (dBm) = E (dB μ V/m) - Correction Factor @ 3m.
2. Correction Factor (dB) = 20log(D) – 104.8; where D is the measurement distance @3m.

Mode	TX channel 20525	Frequency Range	Below 1000 MHz
------	------------------	-----------------	----------------

Antenna Polarity & Test Distance: Horizontal at 3 M

No.	Freq. (MHz)	Reading (dB μ V/m)	Correction Factor (dB)	EIRP (dBm)	Limit (dBm)	Margin (dB)
1	85.34	39.43	-95.26	-55.83	-13	-42.83
2	138.48	41.02	-95.26	-54.24	-13	-41.24
3	288.83	37.41	-95.26	-57.85	-13	-44.85
4	347.27	34.43	-95.26	-60.83	-13	-47.83

Antenna Polarity & Test Distance: Vertical at 3 M

No.	Freq. (MHz)	Reading (dB μ V/m)	Correction Factor (dB)	EIRP (dBm)	Limit (dBm)	Margin (dB)
1	67.57	30.4	-95.26	-64.86	-13	-51.86
2	93.21	33.55	-95.26	-61.71	-13	-48.71
3	128.83	28.27	-95.26	-66.99	-13	-53.99
4	238.96	31.04	-95.26	-64.22	-13	-51.22

Remarks:

1. Follow ANSI 63.26 section 5.2.7 d), EIRP Value (dBm) = E (dB μ V/m) - Correction Factor @ 3m.
2. Correction Factor (dB) = 20log(D) - 104.8; where D is the measurement distance @3m.

Mode	TX channel 20643	Frequency Range	Below 1000 MHz
------	------------------	-----------------	----------------

Antenna Polarity & Test Distance: Horizontal at 3 M

No.	Freq. (MHz)	Reading (dB μ V/m)	Correction Factor (dB)	EIRP (dBm)	Limit (dBm)	Margin (dB)
1	88.3	37.02	-95.26	-58.24	-13	-45.24
2	136.92	37.27	-95.26	-57.99	-13	-44.99
3	287.96	35.41	-95.26	-59.85	-13	-46.85
4	344.44	33.92	-95.26	-61.34	-13	-48.34

Antenna Polarity & Test Distance: Vertical at 3 M

No.	Freq. (MHz)	Reading (dB μ V/m)	Correction Factor (dB)	EIRP (dBm)	Limit (dBm)	Margin (dB)
1	67.39	28.38	-95.26	-66.88	-13	-53.88
2	93.89	33.37	-95.26	-61.89	-13	-48.89
3	127.18	26.61	-95.26	-68.65	-13	-55.65
4	237.88	32.57	-95.26	-62.69	-13	-49.69

Remarks:

1. Follow ANSI 63.26 section 5.2.7 d), EIRP Value (dBm) = E (dB μ V/m) - Correction Factor @ 3m.
2. Correction Factor (dB) = 20log(D) - 104.8; where D is the measurement distance @3m.

LTE Band 5: 3MHz

Mode	TX channel 20415	Frequency Range	Below 1000 MHz
------	------------------	-----------------	----------------

Antenna Polarity & Test Distance: Horizontal at 3 M

No.	Freq. (MHz)	Reading (dB μ V/m)	Correction Factor (dB)	EIRP (dBm)	Limit (dBm)	Margin (dB)
1	82.52	35.67	-95.26	-59.59	-13	-46.59
2	134.46	39.81	-95.26	-55.45	-13	-42.45
3	289.28	38.43	-95.26	-56.83	-13	-43.83
4	349.72	33.4	-95.26	-61.86	-13	-48.86

Antenna Polarity & Test Distance: Vertical at 3 M

No.	Freq. (MHz)	Reading (dB μ V/m)	Correction Factor (dB)	EIRP (dBm)	Limit (dBm)	Margin (dB)
1	62.95	28.13	-95.26	-67.13	-13	-54.13
2	93.98	31.03	-95.26	-64.23	-13	-51.23
3	129.36	28.61	-95.26	-66.65	-13	-53.65
4	237.79	31.99	-95.26	-63.27	-13	-50.27

Remarks:

1. Follow ANSI 63.26 section 5.2.7 d), EIRP Value (dBm) = E (dB μ V/m) - Correction Factor @ 3m.
2. Correction Factor (dB) = 20log(D) – 104.8; where D is the measurement distance @3m.

Mode	TX channel 20525	Frequency Range	Below 1000 MHz
------	------------------	-----------------	----------------

Antenna Polarity & Test Distance: Horizontal at 3 M

No.	Freq. (MHz)	Reading (dB μ V/m)	Correction Factor (dB)	EIRP (dBm)	Limit (dBm)	Margin (dB)
1	86.86	36.41	-95.26	-58.85	-13	-45.85
2	136.94	40.83	-95.26	-54.43	-13	-41.43
3	287.57	36.27	-95.26	-58.99	-13	-45.99
4	349.49	35.29	-95.26	-59.97	-13	-46.97

Antenna Polarity & Test Distance: Vertical at 3 M

No.	Freq. (MHz)	Reading (dB μ V/m)	Correction Factor (dB)	EIRP (dBm)	Limit (dBm)	Margin (dB)
1	65.72	29.18	-95.26	-66.08	-13	-53.08
2	93.77	32.42	-95.26	-62.84	-13	-49.84
3	130.84	27.67	-95.26	-67.59	-13	-54.59
4	239.84	32.2	-95.26	-63.06	-13	-50.06

Remarks:

1. Follow ANSI 63.26 section 5.2.7 d), EIRP Value (dBm) = E (dB μ V/m) - Correction Factor @ 3m.
2. Correction Factor (dB) = 20log(D) - 104.8; where D is the measurement distance @3m.

Mode	TX channel 20635	Frequency Range	Below 1000 MHz
------	------------------	-----------------	----------------

Antenna Polarity & Test Distance: Horizontal at 3 M

No.	Freq. (MHz)	Reading (dB μ V/m)	Correction Factor (dB)	EIRP (dBm)	Limit (dBm)	Margin (dB)
1	85.58	38.31	-95.26	-56.95	-13	-43.95
2	139.05	39.58	-95.26	-55.68	-13	-42.68
3	286.5	37.14	-95.26	-58.12	-13	-45.12
4	348.19	33.17	-95.26	-62.09	-13	-49.09

Antenna Polarity & Test Distance: Vertical at 3 M

No.	Freq. (MHz)	Reading (dB μ V/m)	Correction Factor (dB)	EIRP (dBm)	Limit (dBm)	Margin (dB)
1	66.13	29.51	-95.26	-65.75	-13	-52.75
2	91.54	31.39	-95.26	-63.87	-13	-50.87
3	129.21	28.4	-95.26	-66.86	-13	-53.86
4	240.77	33.16	-95.26	-62.10	-13	-49.10

Remarks:

1. Follow ANSI 63.26 section 5.2.7 d), EIRP Value (dBm) = E (dB μ V/m) - Correction Factor @ 3m.
2. Correction Factor (dB) = 20log(D) - 104.8; where D is the measurement distance @3m.

LTE Band 5: 5MHz

Mode	TX channel 20425	Frequency Range	Below 1000 MHz
------	------------------	-----------------	----------------

Antenna Polarity & Test Distance: Horizontal at 3 M

No.	Freq. (MHz)	Reading (dB μ V/m)	Correction Factor (dB)	EIRP (dBm)	Limit (dBm)	Margin (dB)
1	84.77	37.73	-95.26	-57.53	-13	-44.53
2	139.53	36.88	-95.26	-58.38	-13	-45.38
3	289.72	38.17	-95.26	-57.09	-13	-44.09
4	344.72	34.41	-95.26	-60.85	-13	-47.85

Antenna Polarity & Test Distance: Vertical at 3 M

No.	Freq. (MHz)	Reading (dB μ V/m)	Correction Factor (dB)	EIRP (dBm)	Limit (dBm)	Margin (dB)
1	67.91	30.84	-95.26	-64.42	-13	-51.42
2	91.61	31.97	-95.26	-63.29	-13	-50.29
3	130.7	27.04	-95.26	-68.22	-13	-55.22
4	238.57	31.45	-95.26	-63.81	-13	-50.81

Remarks:

1. Follow ANSI 63.26 section 5.2.7 d), EIRP Value (dBm) = E (dB μ V/m) - Correction Factor @ 3m.
2. Correction Factor (dB) = 20log(D) - 104.8; where D is the measurement distance @3m.

Mode	TX channel 20525	Frequency Range	Below 1000 MHz
------	------------------	-----------------	----------------

Antenna Polarity & Test Distance: Horizontal at 3 M

No.	Freq. (MHz)	Reading (dB μ V/m)	Correction Factor (dB)	EIRP (dBm)	Limit (dBm)	Margin (dB)
1	86.04	37.69	-95.26	-57.57	-13	-44.57
2	137.6	37.65	-95.26	-57.61	-13	-44.61
3	289.02	35.47	-95.26	-59.79	-13	-46.79
4	346.3	35.39	-95.26	-59.87	-13	-46.87

Antenna Polarity & Test Distance: Vertical at 3 M

No.	Freq. (MHz)	Reading (dB μ V/m)	Correction Factor (dB)	EIRP (dBm)	Limit (dBm)	Margin (dB)
1	65.62	29.67	-95.26	-65.59	-13	-52.59
2	91.59	32.46	-95.26	-62.80	-13	-49.80
3	126.78	27.17	-95.26	-68.09	-13	-55.09
4	237.08	30.3	-95.26	-64.96	-13	-51.96

Remarks:

1. Follow ANSI 63.26 section 5.2.7 d), EIRP Value (dBm) = E (dB μ V/m) - Correction Factor @ 3m.
2. Correction Factor (dB) = 20log(D) - 104.8; where D is the measurement distance @3m.

Mode	TX channel 20625	Frequency Range	Below 1000 MHz
------	------------------	-----------------	----------------

Antenna Polarity & Test Distance: Horizontal at 3 M

No.	Freq. (MHz)	Reading (dB μ V/m)	Correction Factor (dB)	EIRP (dBm)	Limit (dBm)	Margin (dB)
1	85.32	34.44	-95.26	-60.82	-13	-47.82
2	139.19	36.15	-95.26	-59.11	-13	-46.11
3	287.1	36.44	-95.26	-58.82	-13	-45.82
4	346.16	33.63	-95.26	-61.63	-13	-48.63

Antenna Polarity & Test Distance: Vertical at 3 M

No.	Freq. (MHz)	Reading (dB μ V/m)	Correction Factor (dB)	EIRP (dBm)	Limit (dBm)	Margin (dB)
1	64.34	30.23	-95.26	-65.03	-13	-52.03
2	94.33	32.3	-95.26	-62.96	-13	-49.96
3	126.65	27.69	-95.26	-67.57	-13	-54.57
4	237.74	33.26	-95.26	-62.00	-13	-49.00

Remarks:

1. Follow ANSI 63.26 section 5.2.7 d), EIRP Value (dBm) = E (dB μ V/m) - Correction Factor @ 3m.
2. Correction Factor (dB) = 20log(D) - 104.8; where D is the measurement distance @3m.

LTE Band 5: 10MHz

Mode	TX channel 20450	Frequency Range	Below 1000 MHz
------	------------------	-----------------	----------------

Antenna Polarity & Test Distance: Horizontal at 3 M

No.	Freq. (MHz)	Reading (dB μ V/m)	Correction Factor (dB)	EIRP (dBm)	Limit (dBm)	Margin (dB)
1	86.66	37.42	-95.26	-57.84	-13	-44.84
2	136.06	38.03	-95.26	-57.23	-13	-44.23
3	291.24	35.77	-95.26	-59.49	-13	-46.49
4	347.63	33.63	-95.26	-61.63	-13	-48.63

Antenna Polarity & Test Distance: Vertical at 3 M

No.	Freq. (MHz)	Reading (dB μ V/m)	Correction Factor (dB)	EIRP (dBm)	Limit (dBm)	Margin (dB)
1	69.54	29.06	-95.26	-66.20	-13	-53.20
2	93.42	32.13	-95.26	-63.13	-13	-50.13
3	129.21	27.71	-95.26	-67.55	-13	-54.55
4	239.18	30.7	-95.26	-64.56	-13	-51.56

Remarks:

1. Follow ANSI 63.26 section 5.2.7 d), EIRP Value (dBm) = E (dB μ V/m) - Correction Factor @ 3m.
2. Correction Factor (dB) = 20log(D) - 104.8; where D is the measurement distance @3m.

Mode	TX channel 20525	Frequency Range	Below 1000 MHz
------	------------------	-----------------	----------------

Antenna Polarity & Test Distance: Horizontal at 3 M

No.	Freq. (MHz)	Reading (dB μ V/m)	Correction Factor (dB)	EIRP (dBm)	Limit (dBm)	Margin (dB)
1	83.67	35.44	-95.26	-59.82	-13	-46.82
2	137.02	40.16	-95.26	-55.10	-13	-42.10
3	286.21	38.29	-95.26	-56.97	-13	-43.97
4	342.46	33.95	-95.26	-61.31	-13	-48.31

Antenna Polarity & Test Distance: Vertical at 3 M

No.	Freq. (MHz)	Reading (dB μ V/m)	Correction Factor (dB)	EIRP (dBm)	Limit (dBm)	Margin (dB)
1	65.65	31.2	-95.26	-64.06	-13	-51.06
2	92.04	30.82	-95.26	-64.44	-13	-51.44
3	132.14	26.03	-95.26	-69.23	-13	-56.23
4	236.65	31.49	-95.26	-63.77	-13	-50.77

Remarks:

1. Follow ANSI 63.26 section 5.2.7 d), EIRP Value (dBm) = E (dB μ V/m) - Correction Factor @ 3m.
2. Correction Factor (dB) = 20log(D) - 104.8; where D is the measurement distance @3m.

Mode	TX channel 20600	Frequency Range	Below 1000 MHz
------	------------------	-----------------	----------------

Antenna Polarity & Test Distance: Horizontal at 3 M

No.	Freq. (MHz)	Reading (dB μ V/m)	Correction Factor (dB)	EIRP (dBm)	Limit (dBm)	Margin (dB)
1	84.45	35.64	-95.26	-59.62	-13	-46.62
2	134.29	39.35	-95.26	-55.91	-13	-42.91
3	289.98	36.01	-95.26	-59.25	-13	-46.25
4	347.35	32.71	-95.26	-62.55	-13	-49.55

Antenna Polarity & Test Distance: Vertical at 3 M

No.	Freq. (MHz)	Reading (dB μ V/m)	Correction Factor (dB)	EIRP (dBm)	Limit (dBm)	Margin (dB)
1	65	28.36	-95.26	-66.90	-13	-53.90
2	89.91	33.62	-95.26	-61.64	-13	-48.64
3	131.86	27.8	-95.26	-67.46	-13	-54.46
4	237.57	30.31	-95.26	-64.95	-13	-51.95

Remarks:

1. Follow ANSI 63.26 section 5.2.7 d), EIRP Value (dBm) = E (dB μ V/m) - Correction Factor @ 3m.
2. Correction Factor (dB) = 20log(D) - 104.8; where D is the measurement distance @3m.

LTE CA_5C (5MHz+10MHz)

Mode	TX channel 20528+20600	Frequency Range	Below 1000 MHz
------	------------------------	-----------------	----------------

Antenna Polarity & Test Distance: Horizontal at 3 M

No.	Freq. (MHz)	Reading (dB μ V/m)	Correction Factor (dB)	EIRP (dBm)	Limit (dBm)	Margin (dB)
1	88.12	32.13	-95.26	-63.13	-13	-50.13
2	140.32	30.08	-95.26	-65.18	-13	-52.18
3	287.87	35.99	-95.26	-59.27	-13	-46.27
4	346.53	37.12	-95.26	-58.14	-13	-45.14

Antenna Polarity & Test Distance: Vertical at 3 M

No.	Freq. (MHz)	Reading (dB μ V/m)	Correction Factor (dB)	EIRP (dBm)	Limit (dBm)	Margin (dB)
1	65.63	35.6	-95.26	-59.66	-13	-46.66
2	93.55	31.72	-95.26	-63.54	-13	-50.54
3	131.19	38.5	-95.26	-56.76	-13	-43.76
4	240.04	41.17	-95.26	-54.09	-13	-41.09

Remarks:

1. Follow ANSI 63.26 section 5.2.7 d), EIRP Value (dBm) = E (dB μ V/m) - Correction Factor @ 3m.
2. Correction Factor (dB) = 20log(D) - 104.8; where D is the measurement distance @3m.

LTE Band 26: 1.4MHz

Mode	TX channel 26797	Frequency Range	Below 1000 MHz
------	------------------	-----------------	----------------

Antenna Polarity & Test Distance: Horizontal at 3 M

No.	Freq. (MHz)	Reading (dB μ V/m)	Correction Factor (dB)	EIRP (dBm)	Limit (dBm)	Margin (dB)
1	81.21	36	-95.26	-59.26	-13	-46.26
2	134.71	35.47	-95.26	-59.79	-13	-46.79
3	289.33	35.01	-95.26	-60.25	-13	-47.25
4	345.9	32.97	-95.26	-62.29	-13	-49.29

Antenna Polarity & Test Distance: Vertical at 3 M

No.	Freq. (MHz)	Reading (dB μ V/m)	Correction Factor (dB)	EIRP (dBm)	Limit (dBm)	Margin (dB)
1	63.54	28.43	-95.26	-66.83	-13	-53.83
2	89	31.79	-95.26	-63.47	-13	-50.47
3	131.53	27.92	-95.26	-67.34	-13	-54.34
4	238.11	31.15	-95.26	-64.11	-13	-51.11

Remarks:

1. Follow ANSI 63.26 section 5.2.7 d), EIRP Value (dBm) = E (dB μ V/m) - Correction Factor @ 3m.
2. Correction Factor (dB) = 20log(D) – 104.8; where D is the measurement distance @3m.

Mode	TX channel 26915	Frequency Range	Below 1000 MHz
------	------------------	-----------------	----------------

Antenna Polarity & Test Distance: Horizontal at 3 M

No.	Freq. (MHz)	Reading (dB μ V/m)	Correction Factor (dB)	EIRP (dBm)	Limit (dBm)	Margin (dB)
1	87.33	37.02	-95.26	-58.24	-13	-45.24
2	135.51	34.63	-95.26	-60.63	-13	-47.63
3	287.4	34.29	-95.26	-60.97	-13	-47.97
4	349.35	30.18	-95.26	-65.08	-13	-52.08

Antenna Polarity & Test Distance: Vertical at 3 M

No.	Freq. (MHz)	Reading (dB μ V/m)	Correction Factor (dB)	EIRP (dBm)	Limit (dBm)	Margin (dB)
1	63.5	29.46	-95.26	-65.80	-13	-52.80
2	94.66	33.41	-95.26	-61.85	-13	-48.85
3	131.12	28.1	-95.26	-67.16	-13	-54.16
4	235.16	33.05	-95.26	-62.21	-13	-49.21

Remarks:

1. Follow ANSI 63.26 section 5.2.7 d), EIRP Value (dBm) = E (dB μ V/m) - Correction Factor @ 3m.
2. Correction Factor (dB) = 20log(D) - 104.8; where D is the measurement distance @3m.

Mode	TX channel 27033	Frequency Range	Below 1000 MHz
------	------------------	-----------------	----------------

Antenna Polarity & Test Distance: Horizontal at 3 M

No.	Freq. (MHz)	Reading (dB μ V/m)	Correction Factor (dB)	EIRP (dBm)	Limit (dBm)	Margin (dB)
1	83.07	35.02	-95.26	-60.24	-13	-47.24
2	134.81	34.97	-95.26	-60.29	-13	-47.29
3	288.97	31.77	-95.26	-63.49	-13	-50.49
4	348.33	33.87	-95.26	-61.39	-13	-48.39

Antenna Polarity & Test Distance: Vertical at 3 M

No.	Freq. (MHz)	Reading (dB μ V/m)	Correction Factor (dB)	EIRP (dBm)	Limit (dBm)	Margin (dB)
1	68.75	29.97	-95.26	-65.29	-13	-52.29
2	92.53	32.75	-95.26	-62.51	-13	-49.51
3	126.22	27.87	-95.26	-67.39	-13	-54.39
4	238.69	31.65	-95.26	-63.61	-13	-50.61

Remarks:

1. Follow ANSI 63.26 section 5.2.7 d), EIRP Value (dBm) = E (dB μ V/m) - Correction Factor @ 3m.
2. Correction Factor (dB) = 20log(D) - 104.8; where D is the measurement distance @3m.

LTE Band 26: 3MHz

Mode	TX channel 26805	Frequency Range	Below 1000 MHz
------	------------------	-----------------	----------------

Antenna Polarity & Test Distance: Horizontal at 3 M

No.	Freq. (MHz)	Reading (dB μ V/m)	Correction Factor (dB)	EIRP (dBm)	Limit (dBm)	Margin (dB)
1	83.5	36.58	-95.26	-58.68	-13	-45.68
2	137.34	35.28	-95.26	-59.98	-13	-46.98
3	293.54	32.47	-95.26	-62.79	-13	-49.79
4	347.23	33.1	-95.26	-62.16	-13	-49.16

Antenna Polarity & Test Distance: Vertical at 3 M

No.	Freq. (MHz)	Reading (dB μ V/m)	Correction Factor (dB)	EIRP (dBm)	Limit (dBm)	Margin (dB)
1	64.53	30.34	-95.26	-64.92	-13	-51.92
2	95.15	32.56	-95.26	-62.70	-13	-49.70
3	132.72	27.06	-95.26	-68.20	-13	-55.20
4	240.81	33.14	-95.26	-62.12	-13	-49.12

Remarks:

1. Follow ANSI 63.26 section 5.2.7 d), EIRP Value (dBm) = E (dB μ V/m) - Correction Factor @ 3m.
2. Correction Factor (dB) = 20log(D) – 104.8; where D is the measurement distance @3m.

Mode	TX channel 26915	Frequency Range	Below 1000 MHz
------	------------------	-----------------	----------------

Antenna Polarity & Test Distance: Horizontal at 3 M

No.	Freq. (MHz)	Reading (dB μ V/m)	Correction Factor (dB)	EIRP (dBm)	Limit (dBm)	Margin (dB)
1	81.15	34.91	-95.26	-60.35	-13	-47.35
2	136.62	35.77	-95.26	-59.49	-13	-46.49
3	288.99	34.42	-95.26	-60.84	-13	-47.84
4	347.22	33.07	-95.26	-62.19	-13	-49.19

Antenna Polarity & Test Distance: Vertical at 3 M

No.	Freq. (MHz)	Reading (dB μ V/m)	Correction Factor (dB)	EIRP (dBm)	Limit (dBm)	Margin (dB)
1	68.13	30.6	-95.26	-64.66	-13	-51.66
2	92.97	31.5	-95.26	-63.76	-13	-50.76
3	126.94	27.73	-95.26	-67.53	-13	-54.53
4	235.56	31.36	-95.26	-63.90	-13	-50.90

Remarks:

1. Follow ANSI 63.26 section 5.2.7 d), EIRP Value (dBm) = E (dB μ V/m) - Correction Factor @ 3m.
2. Correction Factor (dB) = 20log(D) - 104.8; where D is the measurement distance @3m.

Mode	TX channel 27025	Frequency Range	Below 1000 MHz
------	------------------	-----------------	----------------

Antenna Polarity & Test Distance: Horizontal at 3 M

No.	Freq. (MHz)	Reading (dB μ V/m)	Correction Factor (dB)	EIRP (dBm)	Limit (dBm)	Margin (dB)
1	80.95	36.37	-95.26	-58.89	-13	-45.89
2	137.54	35.82	-95.26	-59.44	-13	-46.44
3	291.32	32.91	-95.26	-62.35	-13	-49.35
4	347.02	33.46	-95.26	-61.80	-13	-48.80

Antenna Polarity & Test Distance: Vertical at 3 M

No.	Freq. (MHz)	Reading (dB μ V/m)	Correction Factor (dB)	EIRP (dBm)	Limit (dBm)	Margin (dB)
1	65.72	30.79	-95.26	-64.47	-13	-51.47
2	94.07	32.92	-95.26	-62.34	-13	-49.34
3	129.26	28.26	-95.26	-67.00	-13	-54.00
4	239.04	31.38	-95.26	-63.88	-13	-50.88

Remarks:

1. Follow ANSI 63.26 section 5.2.7 d), EIRP Value (dBm) = E (dB μ V/m) - Correction Factor @ 3m.
2. Correction Factor (dB) = 20log(D) - 104.8; where D is the measurement distance @3m.

LTE Band 26: 5MHz

Mode	TX channel 26815	Frequency Range	Below 1000 MHz
------	------------------	-----------------	----------------

Antenna Polarity & Test Distance: Horizontal at 3 M

No.	Freq. (MHz)	Reading (dB μ V/m)	Correction Factor (dB)	EIRP (dBm)	Limit (dBm)	Margin (dB)
1	81.78	35.04	-95.26	-60.22	-13	-47.22
2	137.32	33.96	-95.26	-61.30	-13	-48.30
3	293.61	33.77	-95.26	-61.49	-13	-48.49
4	346.19	32.98	-95.26	-62.28	-13	-49.28

Antenna Polarity & Test Distance: Vertical at 3 M

No.	Freq. (MHz)	Reading (dB μ V/m)	Correction Factor (dB)	EIRP (dBm)	Limit (dBm)	Margin (dB)
1	65.41	29.13	-95.26	-66.13	-13	-53.13
2	93.09	33.81	-95.26	-61.45	-13	-48.45
3	128.35	26.84	-95.26	-68.42	-13	-55.42
4	239.97	31.1	-95.26	-64.16	-13	-51.16

Remarks:

1. Follow ANSI 63.26 section 5.2.7 d), EIRP Value (dBm) = E (dB μ V/m) - Correction Factor @ 3m.
2. Correction Factor (dB) = 20log(D) - 104.8; where D is the measurement distance @3m.

Mode	TX channel 26915	Frequency Range	Below 1000 MHz
------	------------------	-----------------	----------------

Antenna Polarity & Test Distance: Horizontal at 3 M

No.	Freq. (MHz)	Reading (dB μ V/m)	Correction Factor (dB)	EIRP (dBm)	Limit (dBm)	Margin (dB)
1	87.32	36.03	-95.26	-59.23	-13	-46.23
2	139.06	34.48	-95.26	-60.78	-13	-47.78
3	287.83	33.04	-95.26	-62.22	-13	-49.22
4	346.32	32.9	-95.26	-62.36	-13	-49.36

Antenna Polarity & Test Distance: Vertical at 3 M

No.	Freq. (MHz)	Reading (dB μ V/m)	Correction Factor (dB)	EIRP (dBm)	Limit (dBm)	Margin (dB)
1	68.19	30.65	-95.26	-64.61	-13	-51.61
2	93.81	32.62	-95.26	-62.64	-13	-49.64
3	127.11	26.65	-95.26	-68.61	-13	-55.61
4	239.81	32.69	-95.26	-62.57	-13	-49.57

Remarks:

1. Follow ANSI 63.26 section 5.2.7 d), EIRP Value (dBm) = E (dB μ V/m) - Correction Factor @ 3m.
2. Correction Factor (dB) = 20log(D) - 104.8; where D is the measurement distance @3m.

Mode	TX channel 27015	Frequency Range	Below 1000 MHz
------	------------------	-----------------	----------------

Antenna Polarity & Test Distance: Horizontal at 3 M

No.	Freq. (MHz)	Reading (dB μ V/m)	Correction Factor (dB)	EIRP (dBm)	Limit (dBm)	Margin (dB)
1	80.94	35.1	-95.26	-60.16	-13	-47.16
2	139.29	34.21	-95.26	-61.05	-13	-48.05
3	286.5	31.99	-95.26	-63.27	-13	-50.27
4	349.31	31.13	-95.26	-64.13	-13	-51.13

Antenna Polarity & Test Distance: Vertical at 3 M

No.	Freq. (MHz)	Reading (dB μ V/m)	Correction Factor (dB)	EIRP (dBm)	Limit (dBm)	Margin (dB)
1	66.86	28.89	-95.26	-66.37	-13	-53.37
2	91.74	32.15	-95.26	-63.11	-13	-50.11
3	132.53	28.24	-95.26	-67.02	-13	-54.02
4	240.56	31.33	-95.26	-63.93	-13	-50.93

Remarks:

1. Follow ANSI 63.26 section 5.2.7 d), EIRP Value (dBm) = E (dB μ V/m) - Correction Factor @ 3m.
2. Correction Factor (dB) = 20log(D) - 104.8; where D is the measurement distance @3m.

LTE Band 26: 10MHz

Mode	TX channel 26840	Frequency Range	Below 1000 MHz
------	------------------	-----------------	----------------

Antenna Polarity & Test Distance: Horizontal at 3 M

No.	Freq. (MHz)	Reading (dB μ V/m)	Correction Factor (dB)	EIRP (dBm)	Limit (dBm)	Margin (dB)
1	81.16	35.8	-95.26	-59.46	-13	-46.46
2	135.53	35.83	-95.26	-59.43	-13	-46.43
3	288.58	32.69	-95.26	-62.57	-13	-49.57
4	349.16	31.69	-95.26	-63.57	-13	-50.57

Antenna Polarity & Test Distance: Vertical at 3 M

No.	Freq. (MHz)	Reading (dB μ V/m)	Correction Factor (dB)	EIRP (dBm)	Limit (dBm)	Margin (dB)
1	65.19	28.87	-95.26	-66.39	-13	-53.39
2	95.63	31.79	-95.26	-63.47	-13	-50.47
3	127.64	27.75	-95.26	-67.51	-13	-54.51
4	242.1	33.34	-95.26	-61.92	-13	-48.92

Remarks:

1. Follow ANSI 63.26 section 5.2.7 d), EIRP Value (dBm) = E (dB μ V/m) - Correction Factor @ 3m.
2. Correction Factor (dB) = 20log(D) – 104.8; where D is the measurement distance @3m.

Mode	TX channel 26915	Frequency Range	Below 1000 MHz
------	------------------	-----------------	----------------

Antenna Polarity & Test Distance: Horizontal at 3 M

No.	Freq. (MHz)	Reading (dB μ V/m)	Correction Factor (dB)	EIRP (dBm)	Limit (dBm)	Margin (dB)
1	83.63	35.07	-95.26	-60.19	-13	-47.19
2	135.27	35.03	-95.26	-60.23	-13	-47.23
3	288.88	32.82	-95.26	-62.44	-13	-49.44
4	349.01	31.3	-95.26	-63.96	-13	-50.96

Antenna Polarity & Test Distance: Vertical at 3 M

No.	Freq. (MHz)	Reading (dB μ V/m)	Correction Factor (dB)	EIRP (dBm)	Limit (dBm)	Margin (dB)
1	64.72	29.1	-95.26	-66.16	-13	-53.16
2	94.96	32.4	-95.26	-62.86	-13	-49.86
3	129.38	27.27	-95.26	-67.99	-13	-54.99
4	237.6	33.04	-95.26	-62.22	-13	-49.22

Remarks:

1. Follow ANSI 63.26 section 5.2.7 d), EIRP Value (dBm) = E (dB μ V/m) - Correction Factor @ 3m.
2. Correction Factor (dB) = 20log(D) - 104.8; where D is the measurement distance @3m.

Mode	TX channel 26990	Frequency Range	Below 1000 MHz
------	------------------	-----------------	----------------

Antenna Polarity & Test Distance: Horizontal at 3 M

No.	Freq. (MHz)	Reading (dB μ V/m)	Correction Factor (dB)	EIRP (dBm)	Limit (dBm)	Margin (dB)
1	82.63	35.4	-95.26	-59.86	-13	-46.86
2	133.86	36.38	-95.26	-58.88	-13	-45.88
3	291.62	33.94	-95.26	-61.32	-13	-48.32
4	347.49	31.27	-95.26	-63.99	-13	-50.99

Antenna Polarity & Test Distance: Vertical at 3 M

No.	Freq. (MHz)	Reading (dB μ V/m)	Correction Factor (dB)	EIRP (dBm)	Limit (dBm)	Margin (dB)
1	67.71	28.42	-95.26	-66.84	-13	-53.84
2	93.55	32.49	-95.26	-62.77	-13	-49.77
3	127.97	29.07	-95.26	-66.19	-13	-53.19
4	237.12	32.83	-95.26	-62.43	-13	-49.43

Remarks:

1. Follow ANSI 63.26 section 5.2.7 d), EIRP Value (dBm) = E (dB μ V/m) - Correction Factor @ 3m.
2. Correction Factor (dB) = 20log(D) - 104.8; where D is the measurement distance @3m.

LTE Band 26: 15MHz

Mode	TX channel 26865	Frequency Range	Below 1000 MHz
------	------------------	-----------------	----------------

Antenna Polarity & Test Distance: Horizontal at 3 M

No.	Freq. (MHz)	Reading (dB μ V/m)	Correction Factor (dB)	EIRP (dBm)	Limit (dBm)	Margin (dB)
1	84.62	37.56	-95.26	-57.70	-13	-44.70
2	133.85	35.95	-95.26	-59.31	-13	-46.31
3	288.68	32.66	-95.26	-62.60	-13	-49.60
4	347.38	32.73	-95.26	-62.53	-13	-49.53

Antenna Polarity & Test Distance: Vertical at 3 M

No.	Freq. (MHz)	Reading (dB μ V/m)	Correction Factor (dB)	EIRP (dBm)	Limit (dBm)	Margin (dB)
1	68.74	28.4	-95.26	-66.86	-13	-53.86
2	95.01	30.84	-95.26	-64.42	-13	-51.42
3	127.86	28.76	-95.26	-66.50	-13	-53.50
4	241.1	31.56	-95.26	-63.70	-13	-50.70

Remarks:

1. Follow ANSI 63.26 section 5.2.7 d), EIRP Value (dBm) = E (dB μ V/m) - Correction Factor @ 3m.
2. Correction Factor (dB) = 20log(D) - 104.8; where D is the measurement distance @3m.

Mode	TX channel 26915	Frequency Range	Below 1000 MHz
------	------------------	-----------------	----------------

Antenna Polarity & Test Distance: Horizontal at 3 M

No.	Freq. (MHz)	Reading (dB μ V/m)	Correction Factor (dB)	EIRP (dBm)	Limit (dBm)	Margin (dB)
1	84.47	37.17	-95.26	-58.09	-13	-45.09
2	137.19	35.58	-95.26	-59.68	-13	-46.68
3	293.11	32.93	-95.26	-62.33	-13	-49.33
4	348.73	30.99	-95.26	-64.27	-13	-51.27

Antenna Polarity & Test Distance: Vertical at 3 M

No.	Freq. (MHz)	Reading (dB μ V/m)	Correction Factor (dB)	EIRP (dBm)	Limit (dBm)	Margin (dB)
1	63.65	28.23	-95.26	-67.03	-13	-54.03
2	94.19	32.35	-95.26	-62.91	-13	-49.91
3	128.28	26.55	-95.26	-68.71	-13	-55.71
4	236.65	33.75	-95.26	-61.51	-13	-48.51

Remarks:

1. Follow ANSI 63.26 section 5.2.7 d), EIRP Value (dBm) = E (dB μ V/m) - Correction Factor @ 3m.
2. Correction Factor (dB) = 20log(D) - 104.8; where D is the measurement distance @3m.

Mode	TX channel 26965	Frequency Range	Below 1000 MHz
------	------------------	-----------------	----------------

Antenna Polarity & Test Distance: Horizontal at 3 M

No.	Freq. (MHz)	Reading (dB μ V/m)	Correction Factor (dB)	EIRP (dBm)	Limit (dBm)	Margin (dB)
1	84.37	36.21	-95.26	-59.05	-13	-46.05
2	136.09	35.61	-95.26	-59.65	-13	-46.65
3	291.57	35.7	-95.26	-59.56	-13	-46.56
4	345.32	31.51	-95.26	-63.75	-13	-50.75

Antenna Polarity & Test Distance: Vertical at 3 M

No.	Freq. (MHz)	Reading (dB μ V/m)	Correction Factor (dB)	EIRP (dBm)	Limit (dBm)	Margin (dB)
1	65.58	29.64	-95.26	-65.62	-13	-52.62
2	96.09	32.93	-95.26	-62.33	-13	-49.33
3	128.89	27.99	-95.26	-67.27	-13	-54.27
4	241.13	30.58	-95.26	-64.68	-13	-51.68

Remarks:

1. Follow ANSI 63.26 section 5.2.7 d), EIRP Value (dBm) = E (dB μ V/m) - Correction Factor @ 3m.
2. Correction Factor (dB) = 20log(D) - 104.8; where D is the measurement distance @3m.

ABOVE 1GHz

WCDMA:

Mode	TX channel 4132	Frequency Range	Above 1000 MHz
------	-----------------	-----------------	----------------

Antenna Polarity & Test Distance: Horizontal at 3 M

No.	Freq. (MHz)	Reading (dB μ V/m)	Correction Factor (dB)	EIRP (dBm)	Limit (dBm)	Margin (dB)
1	1652.8	32.1	-95.26	-63.16	-13	-50.16
2	2479.2	47.53	-95.26	-47.73	-13	-34.73
3	3305.6	47.46	-95.26	-47.80	-13	-34.80
4	4132	43.38	-95.26	-51.88	-13	-38.88

Antenna Polarity & Test Distance: Vertical at 3 M

No.	Freq. (MHz)	Reading (dB μ V/m)	Correction Factor (dB)	EIRP (dBm)	Limit (dBm)	Margin (dB)
1	1652.8	37.63	-95.26	-57.63	-13	-44.63
2	2479.2	47.59	-95.26	-47.67	-13	-34.67
3	3305.6	47.29	-95.26	-47.97	-13	-34.97
4	4132	44.79	-95.26	-50.47	-13	-37.47

Remarks:

1. Follow ANSI 63.26 section 5.2.7 d), EIRP Value (dBm) = E (dB μ V/m) - Correction Factor @ 3m.
2. Correction Factor (dB) = 20log(D) – 104.8; where D is the measurement distance @3m.

Mode	TX channel 4182	Frequency Range	Above 1000 MHz
------	-----------------	-----------------	----------------

Antenna Polarity & Test Distance: Horizontal at 3 M

No.	Freq. (MHz)	Reading (dB μ V/m)	Correction Factor (dB)	EIRP (dBm)	Limit (dBm)	Margin (dB)
1	1672.8	35.38	-95.26	-59.88	-13	-46.88
2	2509.2	46.46	-95.26	-48.80	-13	-35.80
3	3345.6	45.73	-95.26	-49.53	-13	-36.53
4	4182	44.7	-95.26	-50.56	-13	-37.56

Antenna Polarity & Test Distance: Vertical at 3 M

No.	Freq. (MHz)	Reading (dB μ V/m)	Correction Factor (dB)	EIRP (dBm)	Limit (dBm)	Margin (dB)
1	1672.8	34.59	-95.26	-60.67	-13	-47.67
2	2509.2	47.92	-95.26	-47.34	-13	-34.34
3	3345.6	46.9	-95.26	-48.36	-13	-35.36
4	4182	43.53	-95.26	-51.73	-13	-38.73

Remarks:

1. Follow ANSI 63.26 section 5.2.7 d), EIRP Value (dBm) = E (dB μ V/m) - Correction Factor @ 3m.
2. Correction Factor (dB) = 20log(D) - 104.8; where D is the measurement distance @3m.

Mode	TX channel 4233	Frequency Range	Above 1000 MHz
------	-----------------	-----------------	----------------

Antenna Polarity & Test Distance: Horizontal at 3 M

No.	Freq. (MHz)	Reading (dB μ V/m)	Correction Factor (dB)	EIRP (dBm)	Limit (dBm)	Margin (dB)
1	1693.2	37.63	-95.26	-57.63	-13	-44.63
2	2539.8	45.92	-95.26	-49.34	-13	-36.34
3	3386.4	46.25	-95.26	-49.01	-13	-36.01
4	4233	46.92	-95.26	-48.34	-13	-35.34

Antenna Polarity & Test Distance: Vertical at 3 M

No.	Freq. (MHz)	Reading (dB μ V/m)	Correction Factor (dB)	EIRP (dBm)	Limit (dBm)	Margin (dB)
1	1693.2	33.84	-95.26	-61.42	-13	-48.42
2	2539.8	48.19	-95.26	-47.07	-13	-34.07
3	3386.4	46.33	-95.26	-48.93	-13	-35.93
4	4233	46.96	-95.26	-48.30	-13	-35.30

Remarks:

1. Follow ANSI 63.26 section 5.2.7 d), EIRP Value (dBm) = E (dB μ V/m) - Correction Factor @ 3m.
2. Correction Factor (dB) = 20log(D) - 104.8; where D is the measurement distance @3m.

LTE Band 5: 1.4MHz

Mode	TX channel 20407	Frequency Range	Above 1000 MHz
------	------------------	-----------------	----------------

Antenna Polarity & Test Distance: Horizontal at 3 M

No.	Freq. (MHz)	Reading (dB μ V/m)	Correction Factor (dB)	EIRP (dBm)	Limit (dBm)	Margin (dB)
1	1649.4	35.18	-95.26	-60.08	-13	-47.08
2	2474.1	40.94	-95.26	-54.32	-13	-41.32
3	3298.8	40.45	-95.26	-54.81	-13	-41.81
4	4123.5	39.97	-95.26	-55.29	-13	-42.29

Antenna Polarity & Test Distance: Vertical at 3 M

No.	Freq. (MHz)	Reading (dB μ V/m)	Correction Factor (dB)	EIRP (dBm)	Limit (dBm)	Margin (dB)
1	1649.4	32.35	-95.26	-62.91	-13	-49.91
2	2474.1	39.84	-95.26	-55.42	-13	-42.42
3	3298.8	37.87	-95.26	-57.39	-13	-44.39
4	4123.5	37.22	-95.26	-58.04	-13	-45.04

Remarks:

1. Follow ANSI 63.26 section 5.2.7 d), EIRP Value (dBm) = E (dB μ V/m) - Correction Factor @ 3m.
2. Correction Factor (dB) = 20log(D) – 104.8; where D is the measurement distance @3m.

Mode	TX channel 20525	Frequency Range	Above 1000 MHz
------	------------------	-----------------	----------------

Antenna Polarity & Test Distance: Horizontal at 3 M

No.	Freq. (MHz)	Reading (dB μ V/m)	Correction Factor (dB)	EIRP (dBm)	Limit (dBm)	Margin (dB)
1	1673	34.77	-95.26	-60.49	-13	-47.49
2	2509.5	41.98	-95.26	-53.28	-13	-40.28
3	3346	41.27	-95.26	-53.99	-13	-40.99
4	4182.5	40.23	-95.26	-55.03	-13	-42.03

Antenna Polarity & Test Distance: Vertical at 3 M

No.	Freq. (MHz)	Reading (dB μ V/m)	Correction Factor (dB)	EIRP (dBm)	Limit (dBm)	Margin (dB)
1	1673	32.46	-95.26	-62.80	-13	-49.80
2	2509.5	39.01	-95.26	-56.25	-13	-43.25
3	3346	38.21	-95.26	-57.05	-13	-44.05
4	4182.5	37.35	-95.26	-57.91	-13	-44.91

Remarks:

1. Follow ANSI 63.26 section 5.2.7 d), EIRP Value (dBm) = E (dB μ V/m) - Correction Factor @ 3m.
2. Correction Factor (dB) = 20log(D) - 104.8; where D is the measurement distance @3m.

Mode	TX channel 20643	Frequency Range	Above 1000 MHz
------	------------------	-----------------	----------------

Antenna Polarity & Test Distance: Horizontal at 3 M

No.	Freq. (MHz)	Reading (dB μ V/m)	Correction Factor (dB)	EIRP (dBm)	Limit (dBm)	Margin (dB)
1	1696.6	35.62	-95.26	-59.64	-13	-46.64
2	2544.9	42.11	-95.26	-53.15	-13	-40.15
3	3393.2	39.77	-95.26	-55.49	-13	-42.49
4	4241.5	39.17	-95.26	-56.09	-13	-43.09

Antenna Polarity & Test Distance: Vertical at 3 M

No.	Freq. (MHz)	Reading (dB μ V/m)	Correction Factor (dB)	EIRP (dBm)	Limit (dBm)	Margin (dB)
1	1696.6	33.53	-95.26	-61.73	-13	-48.73
2	2544.9	38.47	-95.26	-56.79	-13	-43.79
3	3393.2	38.98	-95.26	-56.28	-13	-43.28
4	4241.5	38.37	-95.26	-56.89	-13	-43.89

Remarks:

1. Follow ANSI 63.26 section 5.2.7 d), EIRP Value (dBm) = E (dB μ V/m) - Correction Factor @ 3m.
2. Correction Factor (dB) = 20log(D) - 104.8; where D is the measurement distance @3m.

LTE Band 5: 3MHz

Mode	TX channel 20415	Frequency Range	Above 1000 MHz
------	------------------	-----------------	----------------

Antenna Polarity & Test Distance: Horizontal at 3 M

No.	Freq. (MHz)	Reading (dB μ V/m)	Correction Factor (dB)	EIRP (dBm)	Limit (dBm)	Margin (dB)
1	1651	35.2	-95.26	-60.06	-13	-47.06
2	2476.5	40.71	-95.26	-54.55	-13	-41.55
3	3302	38.06	-95.26	-57.20	-13	-44.20
4	4127.5	39.95	-95.26	-55.31	-13	-42.31

Antenna Polarity & Test Distance: Vertical at 3 M

No.	Freq. (MHz)	Reading (dB μ V/m)	Correction Factor (dB)	EIRP (dBm)	Limit (dBm)	Margin (dB)
1	1651	33.15	-95.26	-62.11	-13	-49.11
2	2476.5	39.58	-95.26	-55.68	-13	-42.68
3	3302	36.28	-95.26	-58.98	-13	-45.98
4	4127.5	36.99	-95.26	-58.27	-13	-45.27

Remarks:

1. Follow ANSI 63.26 section 5.2.7 d), EIRP Value (dBm) = E (dB μ V/m) - Correction Factor @ 3m.
2. Correction Factor (dB) = 20log(D) – 104.8; where D is the measurement distance @3m.

Mode	TX channel 20525	Frequency Range	Above 1000 MHz
------	------------------	-----------------	----------------

Antenna Polarity & Test Distance: Horizontal at 3 M

No.	Freq. (MHz)	Reading (dB μ V/m)	Correction Factor (dB)	EIRP (dBm)	Limit (dBm)	Margin (dB)
1	1673	33.66	-95.26	-61.60	-13	-48.60
2	2509.5	40.49	-95.26	-54.77	-13	-41.77
3	3346	39.54	-95.26	-55.72	-13	-42.72
4	4182.5	38.36	-95.26	-56.90	-13	-43.90

Antenna Polarity & Test Distance: Vertical at 3 M

No.	Freq. (MHz)	Reading (dB μ V/m)	Correction Factor (dB)	EIRP (dBm)	Limit (dBm)	Margin (dB)
1	1673	32.62	-95.26	-62.64	-13	-49.64
2	2509.5	38.94	-95.26	-56.32	-13	-43.32
3	3346	36.19	-95.26	-59.07	-13	-46.07
4	4182.5	37.81	-95.26	-57.45	-13	-44.45

Remarks:

1. Follow ANSI 63.26 section 5.2.7 d), EIRP Value (dBm) = E (dB μ V/m) - Correction Factor @ 3m.
2. Correction Factor (dB) = 20log(D) - 104.8; where D is the measurement distance @3m.

Mode	TX channel 20635	Frequency Range	Above 1000 MHz
------	------------------	-----------------	----------------

Antenna Polarity & Test Distance: Horizontal at 3 M

No.	Freq. (MHz)	Reading (dB μ V/m)	Correction Factor (dB)	EIRP (dBm)	Limit (dBm)	Margin (dB)
1	1695	34.75	-95.26	-60.51	-13	-47.51
2	2542.5	44.78	-95.26	-50.48	-13	-37.48
3	3390	47.6	-95.26	-47.66	-13	-34.66
4	4237.5	46.46	-95.26	-48.80	-13	-35.80

Antenna Polarity & Test Distance: Vertical at 3 M

No.	Freq. (MHz)	Reading (dB μ V/m)	Correction Factor (dB)	EIRP (dBm)	Limit (dBm)	Margin (dB)
1	1695	35.46	-95.26	-59.80	-13	-46.80
2	2542.5	38.49	-95.26	-56.77	-13	-43.77
3	3390	36.9	-95.26	-58.36	-13	-45.36
4	4237.5	36.33	-95.26	-58.93	-13	-45.93

Remarks:

1. Follow ANSI 63.26 section 5.2.7 d), EIRP Value (dBm) = E (dB μ V/m) - Correction Factor @ 3m.
2. Correction Factor (dB) = 20log(D) - 104.8; where D is the measurement distance @3m.

LTE Band 5: 5MHz

Mode	TX channel 20425	Frequency Range	Above 1000 MHz
------	------------------	-----------------	----------------

Antenna Polarity & Test Distance: Horizontal at 3 M

No.	Freq. (MHz)	Reading (dB μ V/m)	Correction Factor (dB)	EIRP (dBm)	Limit (dBm)	Margin (dB)
1	1653	33.95	-95.26	-61.31	-13	-48.31
2	2479.5	42.91	-95.26	-52.35	-13	-39.35
3	3306	47.31	-95.26	-47.95	-13	-34.95
4	4132.5	45.1	-95.26	-50.16	-13	-37.16

Antenna Polarity & Test Distance: Vertical at 3 M

No.	Freq. (MHz)	Reading (dB μ V/m)	Correction Factor (dB)	EIRP (dBm)	Limit (dBm)	Margin (dB)
1	1653	33.83	-95.26	-61.43	-13	-48.43
2	2479.5	38.75	-95.26	-56.51	-13	-43.51
3	3306	35.39	-95.26	-59.87	-13	-46.87
4	4132.5	37.89	-95.26	-57.37	-13	-44.37

Remarks:

1. Follow ANSI 63.26 section 5.2.7 d), EIRP Value (dBm) = E (dB μ V/m) - Correction Factor @ 3m.
2. Correction Factor (dB) = 20log(D) - 104.8; where D is the measurement distance @3m.

Mode	TX channel 20525	Frequency Range	Above 1000 MHz
------	------------------	-----------------	----------------

Antenna Polarity & Test Distance: Horizontal at 3 M

No.	Freq. (MHz)	Reading (dB μ V/m)	Correction Factor (dB)	EIRP (dBm)	Limit (dBm)	Margin (dB)
1	1673	36.44	-95.26	-58.82	-13	-45.82
2	2509.5	42.78	-95.26	-52.48	-13	-39.48
3	3346	45.46	-95.26	-49.80	-13	-36.80
4	4182.5	44.07	-95.26	-51.19	-13	-38.19

Antenna Polarity & Test Distance: Vertical at 3 M

No.	Freq. (MHz)	Reading (dB μ V/m)	Correction Factor (dB)	EIRP (dBm)	Limit (dBm)	Margin (dB)
1	1673	31.72	-95.26	-63.54	-13	-50.54
2	2509.5	42.43	-95.26	-52.83	-13	-39.83
3	3346	38.82	-95.26	-56.44	-13	-43.44
4	4182.5	35.08	-95.26	-60.18	-13	-47.18

Remarks:

1. Follow ANSI 63.26 section 5.2.7 d), EIRP Value (dBm) = E (dB μ V/m) - Correction Factor @ 3m.
2. Correction Factor (dB) = 20log(D) - 104.8; where D is the measurement distance @3m.

Mode	TX channel 20625	Frequency Range	Above 1000 MHz
------	------------------	-----------------	----------------

Antenna Polarity & Test Distance: Horizontal at 3 M

No.	Freq. (MHz)	Reading (dB μ V/m)	Correction Factor (dB)	EIRP (dBm)	Limit (dBm)	Margin (dB)
1	1693	32.85	-95.26	-62.41	-13	-49.41
2	2539.5	40.82	-95.26	-54.44	-13	-41.44
3	3386	41.07	-95.26	-54.19	-13	-41.19
4	4232.5	38.75	-95.26	-56.51	-13	-43.51

Antenna Polarity & Test Distance: Vertical at 3 M

No.	Freq. (MHz)	Reading (dB μ V/m)	Correction Factor (dB)	EIRP (dBm)	Limit (dBm)	Margin (dB)
1	1693	32.95	-95.26	-62.31	-13	-49.31
2	2539.5	41.7	-95.26	-53.56	-13	-40.56
3	3386	37.35	-95.26	-57.91	-13	-44.91
4	4232.5	40.34	-95.26	-54.92	-13	-41.92

Remarks:

1. Follow ANSI 63.26 section 5.2.7 d), EIRP Value (dBm) = E (dB μ V/m) - Correction Factor @ 3m.
2. Correction Factor (dB) = 20log(D) - 104.8; where D is the measurement distance @3m.

LTE Band 5: 10MHz

Mode	TX channel 20450	Frequency Range	Above 1000 MHz
------	------------------	-----------------	----------------

Antenna Polarity & Test Distance: Horizontal at 3 M

No.	Freq. (MHz)	Reading (dB μ V/m)	Correction Factor (dB)	EIRP (dBm)	Limit (dBm)	Margin (dB)
1	1658	35.62	-95.26	-59.64	-13	-46.64
2	2487	44.38	-95.26	-50.88	-13	-37.88
3	3316	46.86	-95.26	-48.40	-13	-35.40
4	4145	46.53	-95.26	-48.73	-13	-35.73

Antenna Polarity & Test Distance: Vertical at 3 M

No.	Freq. (MHz)	Reading (dB μ V/m)	Correction Factor (dB)	EIRP (dBm)	Limit (dBm)	Margin (dB)
1	1658	34.11	-95.26	-61.15	-13	-48.15
2	2487	39.17	-95.26	-56.09	-13	-43.09
3	3316	36.32	-95.26	-58.94	-13	-45.94
4	4145	36.94	-95.26	-58.32	-13	-45.32

Remarks:

1. Follow ANSI 63.26 section 5.2.7 d), EIRP Value (dBm) = E (dB μ V/m) - Correction Factor @ 3m.
2. Correction Factor (dB) = 20log(D) - 104.8; where D is the measurement distance @3m.

Mode	TX channel 20525	Frequency Range	Above 1000 MHz
------	------------------	-----------------	----------------

Antenna Polarity & Test Distance: Horizontal at 3 M

No.	Freq. (MHz)	Reading (dB μ V/m)	Correction Factor (dB)	EIRP (dBm)	Limit (dBm)	Margin (dB)
1	1673	36.24	-95.26	-59.02	-13	-46.02
2	2509.5	44.32	-95.26	-50.94	-13	-37.94
3	3346	45.76	-95.26	-49.50	-13	-36.50
4	4182.5	46.63	-95.26	-48.63	-13	-35.63

Antenna Polarity & Test Distance: Vertical at 3 M

No.	Freq. (MHz)	Reading (dB μ V/m)	Correction Factor (dB)	EIRP (dBm)	Limit (dBm)	Margin (dB)
1	1673	30.46	-95.26	-64.80	-13	-51.80
2	2509.5	40.83	-95.26	-54.43	-13	-41.43
3	3346	38	-95.26	-57.26	-13	-44.26
4	4182.5	38.14	-95.26	-57.12	-13	-44.12

Remarks:

1. Follow ANSI 63.26 section 5.2.7 d), EIRP Value (dBm) = E (dB μ V/m) - Correction Factor @ 3m.
2. Correction Factor (dB) = 20log(D) - 104.8; where D is the measurement distance @3m.

Mode	TX channel 20600	Frequency Range	Above 1000 MHz
------	------------------	-----------------	----------------

Antenna Polarity & Test Distance: Horizontal at 3 M

No.	Freq. (MHz)	Reading (dB μ V/m)	Correction Factor (dB)	EIRP (dBm)	Limit (dBm)	Margin (dB)
1	1688	34.15	-95.26	-61.11	-13	-48.11
2	2532	41.98	-95.26	-53.28	-13	-40.28
3	3376	45.19	-95.26	-50.07	-13	-37.07
4	4220	46.54	-95.26	-48.72	-13	-35.72

Antenna Polarity & Test Distance: Vertical at 3 M

No.	Freq. (MHz)	Reading (dB μ V/m)	Correction Factor (dB)	EIRP (dBm)	Limit (dBm)	Margin (dB)
1	1688	32.65	-95.26	-62.61	-13	-49.61
2	2532	40.99	-95.26	-54.27	-13	-41.27
3	3376	41	-95.26	-54.26	-13	-41.26
4	4220	39.79	-95.26	-55.47	-13	-42.47

Remarks:

1. Follow ANSI 63.26 section 5.2.7 d), EIRP Value (dBm) = E (dB μ V/m) - Correction Factor @ 3m.
2. Correction Factor (dB) = 20log(D) - 104.8; where D is the measurement distance @3m.

LTE CA_5C (5MHz+10MHz)

Mode	TX channel 20528+20600	Frequency Range	Above 1000 MHz
------	------------------------	-----------------	----------------

Antenna Polarity & Test Distance: Horizontal at 3 M

No.	Freq. (MHz)	Reading (dB μ V/m)	Correction Factor (dB)	EIRP (dBm)	Limit (dBm)	Margin (dB)
1	1673.6	37.4	-95.26	-57.86	-13	-44.86
2	1688	39.37	-95.26	-55.89	-13	-42.89
3	2510.4	49	-95.26	-46.26	-13	-33.26
4	2532	47.16	-95.26	-48.10	-13	-35.10
5	3347.2	48	-95.26	-47.26	-13	-34.26
6	3376	49.21	-95.26	-46.05	-13	-33.05
7	4184	47.69	-95.26	-47.57	-13	-34.57
8	4220	45.74	-95.26	-49.52	-13	-36.52

Antenna Polarity & Test Distance: Vertical at 3 M

No.	Freq. (MHz)	Reading (dB μ V/m)	Correction Factor (dB)	EIRP (dBm)	Limit (dBm)	Margin (dB)
1	1673.6	38.48	-95.26	-56.78	-13	-43.78
2	1688	37.6	-95.26	-57.66	-13	-44.66
3	2510.4	48.51	-95.26	-46.75	-13	-33.75
4	2532	48.02	-95.26	-47.24	-13	-34.24
5	3347.2	48.67	-95.26	-46.59	-13	-33.59
6	3376	46.74	-95.26	-48.52	-13	-35.52
7	4184	47.61	-95.26	-47.65	-13	-34.65
8	4220	47.26	-95.26	-48.00	-13	-35.00

Remarks:

1. Follow ANSI 63.26 section 5.2.7 d), EIRP Value (dBm) = E (dB μ V/m) - Correction Factor @ 3m.
2. Correction Factor (dB) = 20log(D) - 104.8; where D is the measurement distance @3m.

LTE Band 26: 1.4MHz

Mode	TX channel 26797	Frequency Range	Above 1000 MHz
------	------------------	-----------------	----------------

Antenna Polarity & Test Distance: Horizontal at 3 M

No.	Freq. (MHz)	Reading (dB μ V/m)	Correction Factor (dB)	EIRP (dBm)	Limit (dBm)	Margin (dB)
1	1649.4	31.16	-95.26	-64.10	-13	-51.10
2	2474.1	44.17	-95.26	-51.09	-13	-38.09
3	3298.8	46.9	-95.26	-48.36	-13	-35.36
4	4123.5	45.11	-95.26	-50.15	-13	-37.15

Antenna Polarity & Test Distance: Vertical at 3 M

No.	Freq. (MHz)	Reading (dB μ V/m)	Correction Factor (dB)	EIRP (dBm)	Limit (dBm)	Margin (dB)
1	1649.4	31.82	-95.26	-63.44	-13	-50.44
2	2474.1	41.25	-95.26	-54.01	-13	-41.01
3	3298.8	36.1	-95.26	-59.16	-13	-46.16
4	4123.5	40.18	-95.26	-55.08	-13	-42.08

Remarks:

1. Follow ANSI 63.26 section 5.2.7 d), EIRP Value (dBm) = E (dB μ V/m) - Correction Factor @ 3m.
2. Correction Factor (dB) = 20log(D) – 104.8; where D is the measurement distance @3m.

Mode	TX channel 26915	Frequency Range	Above 1000 MHz
------	------------------	-----------------	----------------

Antenna Polarity & Test Distance: Horizontal at 3 M

No.	Freq. (MHz)	Reading (dB μ V/m)	Correction Factor (dB)	EIRP (dBm)	Limit (dBm)	Margin (dB)
1	1673	34.88	-95.26	-60.38	-13	-47.38
2	2509.5	43.56	-95.26	-51.70	-13	-38.70
3	3346	46.05	-95.26	-49.21	-13	-36.21
4	4182.5	45.79	-95.26	-49.47	-13	-36.47

Antenna Polarity & Test Distance: Vertical at 3 M

No.	Freq. (MHz)	Reading (dB μ V/m)	Correction Factor (dB)	EIRP (dBm)	Limit (dBm)	Margin (dB)
1	1673	32.84	-95.26	-62.42	-13	-49.42
2	2509.5	42.1	-95.26	-53.16	-13	-40.16
3	3346	37.16	-95.26	-58.10	-13	-45.10
4	4182.5	38.3	-95.26	-56.96	-13	-43.96

Remarks:

1. Follow ANSI 63.26 section 5.2.7 d), EIRP Value (dBm) = E (dB μ V/m) - Correction Factor @ 3m.
2. Correction Factor (dB) = 20log(D) - 104.8; where D is the measurement distance @3m.

Mode	TX channel 27033	Frequency Range	Above 1000 MHz
------	------------------	-----------------	----------------

Antenna Polarity & Test Distance: Horizontal at 3 M

No.	Freq. (MHz)	Reading (dB μ V/m)	Correction Factor (dB)	EIRP (dBm)	Limit (dBm)	Margin (dB)
1	1696.6	36.18	-95.26	-59.08	-13	-46.08
2	2544.9	44.27	-95.26	-50.99	-13	-37.99
3	3393.2	48.33	-95.26	-46.93	-13	-33.93
4	4241.5	46.15	-95.26	-49.11	-13	-36.11

Antenna Polarity & Test Distance: Vertical at 3 M

No.	Freq. (MHz)	Reading (dB μ V/m)	Correction Factor (dB)	EIRP (dBm)	Limit (dBm)	Margin (dB)
1	1696.6	34.61	-95.26	-60.65	-13	-47.65
2	2544.9	41.12	-95.26	-54.14	-13	-41.14
3	3393.2	36.8	-95.26	-58.46	-13	-45.46
4	4241.5	36.54	-95.26	-58.72	-13	-45.72

Remarks:

1. Follow ANSI 63.26 section 5.2.7 d), EIRP Value (dBm) = E (dB μ V/m) - Correction Factor @ 3m.
2. Correction Factor (dB) = 20log(D) - 104.8; where D is the measurement distance @3m.

LTE Band 26: 3MHz

Mode	TX channel 26805	Frequency Range	Above 1000 MHz
------	------------------	-----------------	----------------

Antenna Polarity & Test Distance: Horizontal at 3 M

No.	Freq. (MHz)	Reading (dB μ V/m)	Correction Factor (dB)	EIRP (dBm)	Limit (dBm)	Margin (dB)
1	1651	33.06	-95.26	-62.20	-13	-49.20
2	2476.5	44.85	-95.26	-50.41	-13	-37.41
3	3302	43.8	-95.26	-51.46	-13	-38.46
4	4127.5	45.02	-95.26	-50.24	-13	-37.24

Antenna Polarity & Test Distance: Vertical at 3 M

No.	Freq. (MHz)	Reading (dB μ V/m)	Correction Factor (dB)	EIRP (dBm)	Limit (dBm)	Margin (dB)
1	1651	34.97	-95.26	-60.29	-13	-47.29
2	2476.5	41.51	-95.26	-53.75	-13	-40.75
3	3302	37.65	-95.26	-57.61	-13	-44.61
4	4127.5	37.3	-95.26	-57.96	-13	-44.96

Remarks:

1. Follow ANSI 63.26 section 5.2.7 d), EIRP Value (dBm) = E (dB μ V/m) - Correction Factor @ 3m.
2. Correction Factor (dB) = 20log(D) – 104.8; where D is the measurement distance @3m.

Mode	TX channel 26915	Frequency Range	Above 1000 MHz
------	------------------	-----------------	----------------

Antenna Polarity & Test Distance: Horizontal at 3 M

No.	Freq. (MHz)	Reading (dB μ V/m)	Correction Factor (dB)	EIRP (dBm)	Limit (dBm)	Margin (dB)
1	1673	41.19	-95.26	-54.07	-13	-41.07
2	2509.5	35.55	-95.26	-59.71	-13	-46.71
3	3346	44.29	-95.26	-50.97	-13	-37.97
4	4182.5	32.19	-95.26	-63.07	-13	-50.07

Antenna Polarity & Test Distance: Vertical at 3 M

No.	Freq. (MHz)	Reading (dB μ V/m)	Correction Factor (dB)	EIRP (dBm)	Limit (dBm)	Margin (dB)
1	1673	43.1	-95.26	-52.16	-13	-39.16
2	2509.5	30.83	-95.26	-64.43	-13	-51.43
3	3346	38.46	-95.26	-56.80	-13	-43.80
4	4182.5	25.25	-95.26	-70.01	-13	-57.01

Remarks:

1. Follow ANSI 63.26 section 5.2.7 d), EIRP Value (dBm) = E (dB μ V/m) - Correction Factor @ 3m.
2. Correction Factor (dB) = 20log(D) - 104.8; where D is the measurement distance @3m.

Mode	TX channel 27025	Frequency Range	Above 1000 MHz
------	------------------	-----------------	----------------

Antenna Polarity & Test Distance: Horizontal at 3 M

No.	Freq. (MHz)	Reading (dB μ V/m)	Correction Factor (dB)	EIRP (dBm)	Limit (dBm)	Margin (dB)
1	1695	34.33	-95.26	-60.93	-13	-47.93
2	2542.5	45.2	-95.26	-50.06	-13	-37.06
3	3390	46.92	-95.26	-48.34	-13	-35.34
4	4237.5	45.77	-95.26	-49.49	-13	-36.49

Antenna Polarity & Test Distance: Vertical at 3 M

No.	Freq. (MHz)	Reading (dB μ V/m)	Correction Factor (dB)	EIRP (dBm)	Limit (dBm)	Margin (dB)
1	1695	32.23	-95.26	-63.03	-13	-50.03
2	2542.5	39.93	-95.26	-55.33	-13	-42.33
3	3390	38.21	-95.26	-57.05	-13	-44.05
4	4237.5	38.05	-95.26	-57.21	-13	-44.21

Remarks:

1. Follow ANSI 63.26 section 5.2.7 d), EIRP Value (dBm) = E (dB μ V/m) - Correction Factor @ 3m.
2. Correction Factor (dB) = 20log(D) - 104.8; where D is the measurement distance @3m.

LTE Band 26: 5MHz

Mode	TX channel 26815	Frequency Range	Above 1000 MHz
------	------------------	-----------------	----------------

Antenna Polarity & Test Distance: Horizontal at 3 M

No.	Freq. (MHz)	Reading (dB μ V/m)	Correction Factor (dB)	EIRP (dBm)	Limit (dBm)	Margin (dB)
1	1653	33	-95.26	-62.26	-13	-49.26
2	2479.5	43.86	-95.26	-51.40	-13	-38.40
3	3306	45.71	-95.26	-49.55	-13	-36.55
4	4132.5	44.32	-95.26	-50.94	-13	-37.94

Antenna Polarity & Test Distance: Vertical at 3 M

No.	Freq. (MHz)	Reading (dB μ V/m)	Correction Factor (dB)	EIRP (dBm)	Limit (dBm)	Margin (dB)
1	1653	35.72	-95.26	-59.54	-13	-46.54
2	2479.5	38.67	-95.26	-56.59	-13	-43.59
3	3306	36.91	-95.26	-58.35	-13	-45.35
4	4132.5	36.48	-95.26	-58.78	-13	-45.78

Remarks:

1. Follow ANSI 63.26 section 5.2.7 d), EIRP Value (dBm) = E (dB μ V/m) - Correction Factor @ 3m.
2. Correction Factor (dB) = 20log(D) – 104.8; where D is the measurement distance @3m.

Mode	TX channel 26915	Frequency Range	Above 1000 MHz
------	------------------	-----------------	----------------

Antenna Polarity & Test Distance: Horizontal at 3 M

No.	Freq. (MHz)	Reading (dB μ V/m)	Correction Factor (dB)	EIRP (dBm)	Limit (dBm)	Margin (dB)
1	1673	36.04	-95.26	-59.22	-13	-46.22
2	2509.5	46.26	-95.26	-49.00	-13	-36.00
3	3346	46.55	-95.26	-48.71	-13	-35.71
4	4182.5	43.78	-95.26	-51.48	-13	-38.48

Antenna Polarity & Test Distance: Vertical at 3 M

No.	Freq. (MHz)	Reading (dB μ V/m)	Correction Factor (dB)	EIRP (dBm)	Limit (dBm)	Margin (dB)
1	1673	32.5	-95.26	-62.76	-13	-49.76
2	2509.5	38.66	-95.26	-56.60	-13	-43.60
3	3346	39.13	-95.26	-56.13	-13	-43.13
4	4182.5	37.93	-95.26	-57.33	-13	-44.33

Remarks:

1. Follow ANSI 63.26 section 5.2.7 d), EIRP Value (dBm) = E (dB μ V/m) - Correction Factor @ 3m.
2. Correction Factor (dB) = 20log(D) - 104.8; where D is the measurement distance @3m.

Mode	TX channel 27015	Frequency Range	Above 1000 MHz
------	------------------	-----------------	----------------

Antenna Polarity & Test Distance: Horizontal at 3 M

No.	Freq. (MHz)	Reading (dB μ V/m)	Correction Factor (dB)	EIRP (dBm)	Limit (dBm)	Margin (dB)
1	1693	32.66	-95.26	-62.60	-13	-49.60
2	2539.5	44.61	-95.26	-50.65	-13	-37.65
3	3386	45.47	-95.26	-49.79	-13	-36.79
4	4232.5	47.3	-95.26	-47.96	-13	-34.96

Antenna Polarity & Test Distance: Vertical at 3 M

No.	Freq. (MHz)	Reading (dB μ V/m)	Correction Factor (dB)	EIRP (dBm)	Limit (dBm)	Margin (dB)
1	1693	33.23	-95.26	-62.03	-13	-49.03
2	2539.5	41.43	-95.26	-53.83	-13	-40.83
3	3386	38.72	-95.26	-56.54	-13	-43.54
4	4232.5	37.19	-95.26	-58.07	-13	-45.07

Remarks:

1. Follow ANSI 63.26 section 5.2.7 d), EIRP Value (dBm) = E (dB μ V/m) - Correction Factor @ 3m.
2. Correction Factor (dB) = 20log(D) - 104.8; where D is the measurement distance @3m.

LTE Band 26: 10MHz

Mode	TX channel 26840	Frequency Range	Above 1000 MHz
------	------------------	-----------------	----------------

Antenna Polarity & Test Distance: Horizontal at 3 M

No.	Freq. (MHz)	Reading (dB μ V/m)	Correction Factor (dB)	EIRP (dBm)	Limit (dBm)	Margin (dB)
1	1658	33.82	-95.26	-61.44	-13	-48.44
2	2487	44.3	-95.26	-50.96	-13	-37.96
3	3316	43.41	-95.26	-51.85	-13	-38.85
4	4145	45.41	-95.26	-49.85	-13	-36.85

Antenna Polarity & Test Distance: Vertical at 3 M

No.	Freq. (MHz)	Reading (dB μ V/m)	Correction Factor (dB)	EIRP (dBm)	Limit (dBm)	Margin (dB)
1	1658	31.6	-95.26	-63.66	-13	-50.66
2	2487	39.07	-95.26	-56.19	-13	-43.19
3	3316	36.75	-95.26	-58.51	-13	-45.51
4	4145	36.59	-95.26	-58.67	-13	-45.67

Remarks:

1. Follow ANSI 63.26 section 5.2.7 d), EIRP Value (dBm) = E (dB μ V/m) - Correction Factor @ 3m.
2. Correction Factor (dB) = 20log(D) – 104.8; where D is the measurement distance @3m.

Mode	TX channel 26915	Frequency Range	Above 1000 MHz
------	------------------	-----------------	----------------

Antenna Polarity & Test Distance: Horizontal at 3 M

No.	Freq. (MHz)	Reading (dB μ V/m)	Correction Factor (dB)	EIRP (dBm)	Limit (dBm)	Margin (dB)
1	1673	31.62	-95.26	-63.64	-13	-50.64
2	2509.5	43.3	-95.26	-51.96	-13	-38.96
3	3346	46.23	-95.26	-49.03	-13	-36.03
4	4182.5	43.21	-95.26	-52.05	-13	-39.05

Antenna Polarity & Test Distance: Vertical at 3 M

No.	Freq. (MHz)	Reading (dB μ V/m)	Correction Factor (dB)	EIRP (dBm)	Limit (dBm)	Margin (dB)
1	1673	32.93	-95.26	-62.33	-13	-49.33
2	2509.5	40.46	-95.26	-54.80	-13	-41.80
3	3346	38.04	-95.26	-57.22	-13	-44.22
4	4182.5	38.04	-95.26	-57.22	-13	-44.22

Remarks:

1. Follow ANSI 63.26 section 5.2.7 d), EIRP Value (dBm) = E (dB μ V/m) - Correction Factor @ 3m.
2. Correction Factor (dB) = 20log(D) - 104.8; where D is the measurement distance @3m.

Mode	TX channel 26990	Frequency Range	Above 1000 MHz
------	------------------	-----------------	----------------

Antenna Polarity & Test Distance: Horizontal at 3 M

No.	Freq. (MHz)	Reading (dB μ V/m)	Correction Factor (dB)	EIRP (dBm)	Limit (dBm)	Margin (dB)
1	1688	30.94	-95.26	-64.32	-13	-51.32
2	2532	45.14	-95.26	-50.12	-13	-37.12
3	3376	45.08	-95.26	-50.18	-13	-37.18
4	4220	46.21	-95.26	-49.05	-13	-36.05

Antenna Polarity & Test Distance: Vertical at 3 M

No.	Freq. (MHz)	Reading (dB μ V/m)	Correction Factor (dB)	EIRP (dBm)	Limit (dBm)	Margin (dB)
1	1688	32.41	-95.26	-62.85	-13	-49.85
2	2532	40.61	-95.26	-54.65	-13	-41.65
3	3376	38.9	-95.26	-56.36	-13	-43.36
4	4220	37.6	-95.26	-57.66	-13	-44.66

Remarks:

1. Follow ANSI 63.26 section 5.2.7 d), EIRP Value (dBm) = E (dB μ V/m) - Correction Factor @ 3m.
2. Correction Factor (dB) = 20log(D) - 104.8; where D is the measurement distance @3m.

LTE Band 26: 15MHz

Mode	TX channel 26865	Frequency Range	Above 1000 MHz
------	------------------	-----------------	----------------

Antenna Polarity & Test Distance: Horizontal at 3 M

No.	Freq. (MHz)	Reading (dB μ V/m)	Correction Factor (dB)	EIRP (dBm)	Limit (dBm)	Margin (dB)
1	1663	32.5	-95.26	-62.76	-13	-49.76
2	2494.5	46.24	-95.26	-49.02	-13	-36.02
3	3326	46.71	-95.26	-48.55	-13	-35.55
4	4157.5	45.63	-95.26	-49.63	-13	-36.63

Antenna Polarity & Test Distance: Vertical at 3 M

No.	Freq. (MHz)	Reading (dB μ V/m)	Correction Factor (dB)	EIRP (dBm)	Limit (dBm)	Margin (dB)
1	1663	32.37	-95.26	-62.89	-13	-49.89
2	2494.5	42.58	-95.26	-52.68	-13	-39.68
3	3326	34.88	-95.26	-60.38	-13	-47.38
4	4157.5	38.91	-95.26	-56.35	-13	-43.35

Remarks:

1. Follow ANSI 63.26 section 5.2.7 d), EIRP Value (dBm) = E (dB μ V/m) - Correction Factor @ 3m.
2. Correction Factor (dB) = 20log(D) – 104.8; where D is the measurement distance @3m.

Mode	TX channel 26915	Frequency Range	Above 1000 MHz
------	------------------	-----------------	----------------

Antenna Polarity & Test Distance: Horizontal at 3 M

No.	Freq. (MHz)	Reading (dB μ V/m)	Correction Factor (dB)	EIRP (dBm)	Limit (dBm)	Margin (dB)
1	1673	35.53	-95.26	-59.73	-13	-46.73
2	2509.5	44	-95.26	-51.26	-13	-38.26
3	3346	46.28	-95.26	-48.98	-13	-35.98
4	4182.5	44.93	-95.26	-50.33	-13	-37.33

Antenna Polarity & Test Distance: Vertical at 3 M

No.	Freq. (MHz)	Reading (dB μ V/m)	Correction Factor (dB)	EIRP (dBm)	Limit (dBm)	Margin (dB)
1	1673	35.25	-95.26	-60.01	-13	-47.01
2	2509.5	41.73	-95.26	-53.53	-13	-40.53
3	3346	39.28	-95.26	-55.98	-13	-42.98
4	4182.5	39.49	-95.26	-55.77	-13	-42.77

Remarks:

1. Follow ANSI 63.26 section 5.2.7 d), EIRP Value (dBm) = E (dB μ V/m) - Correction Factor @ 3m.
2. Correction Factor (dB) = 20log(D) - 104.8; where D is the measurement distance @3m.

Mode	TX channel 26965	Frequency Range	Above 1000 MHz
------	------------------	-----------------	----------------

Antenna Polarity & Test Distance: Horizontal at 3 M

No.	Freq. (MHz)	Reading (dB μ V/m)	Correction Factor (dB)	EIRP (dBm)	Limit (dBm)	Margin (dB)
1	1682	33.86	-95.26	-61.40	-13	-48.40
2	2523	42.71	-95.26	-52.55	-13	-39.55
3	3364	43.6	-95.26	-51.66	-13	-38.66
4	4205	44.05	-95.26	-51.21	-13	-38.21

Antenna Polarity & Test Distance: Vertical at 3 M

No.	Freq. (MHz)	Reading (dB μ V/m)	Correction Factor (dB)	EIRP (dBm)	Limit (dBm)	Margin (dB)
1	1682	33.27	-95.26	-61.99	-13	-48.99
2	2523	40.46	-95.26	-54.80	-13	-41.80
3	3364	36.94	-95.26	-58.32	-13	-45.32
4	4205	38.33	-95.26	-56.93	-13	-43.93

Remarks:

1. Follow ANSI 63.26 section 5.2.7 d), EIRP Value (dBm) = E (dB μ V/m) - Correction Factor @ 3m.
2. Correction Factor (dB) = 20log(D) - 104.8; where D is the measurement distance @3m.

5 Pictures of Test Arrangements

Please refer to the attached file (Test Setup Photo).

Appendix – Information of the Testing Laboratories

We, Bureau Veritas Consumer Products Services (H.K.) Ltd., Taoyuan Branch, were founded in 1988 to provide our best service in EMC, Radio, Telecom and Safety consultation. Our laboratories are accredited and approved according to ISO/IEC 17025.

If you have any comments, please feel free to contact us at the following:

Lin Kou EMC/RF Lab

Tel: 886-2-26052180

Fax: 886-2-26051924

Hsin Chu EMC/RF/Telecom Lab

Tel: 886-3-6668565

Fax: 886-3-6668323

Hwa Ya EMC/RF/Safety Lab

Tel: 886-3-3183232

Fax: 886-3-3270892

Email: service.adt@tw.bureauveritas.com

Web Site: www.bureauveritas-adt.com

The address and road map of all our labs can be found in our web site also.

--- END ---