



# LM960 HW Design Guide

1VV0301485 Rev.15 – 2020-08-13

**TELIT**  
TECHNICAL  
DOCUMENTATION

## **SPECIFICATIONS ARE SUBJECT TO CHANGE WITHOUT NOTICE**

### **NOTICE**

While reasonable efforts have been made to assure the accuracy of this document, Telit assumes no liability resulting from any inaccuracies or omissions in this document, or from use of the information obtained herein. The information in this document has been carefully checked and is believed to be reliable. However, no responsibility is assumed for inaccuracies or omissions. Telit reserves the right to make changes to any products described herein and reserves the right to revise this document and to make changes from time to time in content hereof with no obligation to notify any person of revisions or changes. Telit does not assume any liability arising out of the application or use of any product, software, or circuit described herein; neither does it convey license under its patent rights or the rights of others.

It is possible that this publication may contain references to, or information about Telit products (machines and programs), programming, or services that are not announced in your country. Such references or information must not be construed to mean that Telit intends to announce such Telit products, programming, or services in your country.

### **COPYRIGHTS**

This instruction manual and the Telit products described in this instruction manual may be, include or describe copyrighted Telit material, such as computer programs stored in semiconductor memories or other media. Laws in the Italy and other countries preserve for Telit and its licensors certain exclusive rights for copyrighted material, including the exclusive right to copy, reproduce in any form, distribute and make derivative works of the copyrighted material. Accordingly, any copyrighted material of Telit and its licensors contained herein or in the Telit products described in this instruction manual may not be copied, reproduced, distributed, merged or modified in any manner without the express written permission of Telit. Furthermore, the purchase of Telit products shall not be deemed to grant either directly or by implication, estoppel, or otherwise, any license under the copyrights, patents or patent applications of Telit, as arises by operation of law in the sale of a product.

### **COMPUTER SOFTWARE COPYRIGHTS**

The Telit and 3rd Party supplied Software (SW) products described in this instruction manual may include copyrighted Telit and other 3rd Party supplied computer programs stored in semiconductor memories or other media. Laws in the Italy and other countries preserve for Telit and other 3rd Party supplied SW certain exclusive rights for copyrighted computer programs, including the exclusive right to copy or reproduce in any form the copyrighted computer program. Accordingly, any copyrighted Telit or other 3rd Party supplied SW computer programs contained in the Telit products described in this instruction manual may not be copied (reverse engineered) or reproduced in any manner without the express written permission of Telit or the 3rd Party SW supplier. Furthermore, the purchase of Telit products shall not be deemed to grant either directly or by implication, estoppel, or otherwise, any license under the copyrights, patents or patent applications of Telit or other

3rd Party supplied SW, except for the normal non-exclusive, royalty free license to use that arises by operation of law in the sale of a product.

## USAGE AND DISCLOSURE RESTRICTIONS

### I. License Agreements

The software described in this document is the property of Telit and its licensors. It is furnished by express license agreement only and may be used only in accordance with the terms of such an agreement.

### II. Copyrighted Materials

Software and documentation are copyrighted materials. Making unauthorized copies is prohibited by law. No part of the software or documentation may be reproduced, transmitted, transcribed, stored in a retrieval system, or translated into any language or computer language, in any form or by any means, without prior written permission of Telit

### III. High Risk Materials

Components, units, or third-party products used in the product described herein are NOT fault-tolerant and are NOT designed, manufactured, or intended for use as on-line control equipment in the following hazardous environments requiring fail-safe controls: the operation of Nuclear Facilities, Aircraft Navigation or Aircraft Communication Systems, Air Traffic Control, Life Support, or Weapons Systems (High Risk Activities"). Telit and its supplier(s) specifically disclaim any expressed or implied warranty of fitness for such High Risk Activities.

### IV. Trademarks

TELIT and the Stylized T Logo are registered in Trademark Office. All other product or service names are the property of their respective owners.

### V. Third Party Rights

The software may include Third Party Right software. In this case you agree to comply with all terms and conditions imposed on you in respect of such separate software. In addition to Third Party Terms, the disclaimer of warranty and limitation of liability provisions in this License shall apply to the Third Party Right software.

TELIT HEREBY DISCLAIMS ANY AND ALL WARRANTIES EXPRESS OR IMPLIED FROM ANY THIRD PARTIES REGARDING ANY SEPARATE FILES, ANY THIRD PARTY MATERIALS INCLUDED IN THE SOFTWARE, ANY THIRD PARTY MATERIALS FROM WHICH THE SOFTWARE IS DERIVED (COLLECTIVELY "OTHER CODE"), AND THE USE OF ANY OR ALL THE OTHER CODE IN CONNECTION WITH THE SOFTWARE, INCLUDING (WITHOUT LIMITATION) ANY WARRANTIES OF SATISFACTORY QUALITY OR FITNESS FOR A PARTICULAR PURPOSE.

NO THIRD PARTY LICENSORS OF OTHER CODE SHALL HAVE ANY LIABILITY FOR ANY DIRECT, INDIRECT, INCIDENTAL, SPECIAL, EXEMPLARY, OR CONSEQUENTIAL DAMAGES (INCLUDING WITHOUT LIMITATION LOST PROFITS), HOWEVER CAUSED AND WHETHER MADE UNDER CONTRACT, TORT OR OTHER LEGAL THEORY, ARISING IN ANY WAY OUT OF THE USE OR DISTRIBUTION OF THE OTHER CODE OR THE EXERCISE OF ANY RIGHTS GRANTED UNDER EITHER OR BOTH THIS LICENSE AND THE LEGAL TERMS APPLICABLE TO ANY SEPARATE FILES, EVEN IF ADVISED OF THE POSSIBILITY OF SUCH DAMAGES.

## Applicability Table

### PRODUCTS

- ■ LM960
- ■ LM960A18
- ■ LM960A9-P

## Contents

### NOTICE 2

### COPYRIGHTS ..... 2

### COMPUTER SOFTWARE COPYRIGHTS..... 2

### USAGE AND DISCLOSURE RESTRICTIONS..... 3

### APPLICABILITY TABLE ..... 5

### CONTENTS ..... 6

### 1. INTRODUCTION ..... 10

#### 1.1. Scope ..... 10

#### 1.2. Audience..... 10

#### 1.3. Contact Information, Support ..... 10

#### 1.4. Text Conventions ..... 12

#### 1.5. Related Documents ..... 13

### 2. GENERAL PRODUCT DESCRIPTION ..... 14

#### 2.1. Overview..... 14

#### 2.2. Product Variants and Frequency Bands..... 14

##### 2.2.1. RF Bands per Regional Variant ..... 14

###### 2.2.1.1. LM960 RF Bands and Carrier Aggregation ..... 14

###### 2.2.1.2. LM960A18 RF Bands and Carrier Aggregation ..... 17

###### 2.2.1.3. LM960A9-P RF Bands and Carrier Aggregation ..... 22

#### 2.3. Target market ..... 22

#### 2.4. Main features ..... 22

#### 2.5. Block Diagram ..... 25

#### 2.6. TX Output Power ..... 26

#### 2.7. RX Sensitivity ..... 26

#### 2.8. Mechanical specifications ..... 27

##### 2.8.1. Dimensions ..... 27

##### 2.8.2. Weight ..... 27

###### 2.8.2.1. LM960/LM960A18 ..... 27

###### 2.8.2.2. LM960A9-P ..... 27

#### 2.9. Environmental Requirements ..... 27

2.9.1.	Temperature Range.....	27
2.9.2.	RoHS Compliance .....	28
<b>3.</b>	<b>PINS ALLOCATION .....</b>	<b>29</b>
3.1.	Pin-out .....	29
3.2.	LM960 Signals That Must Be Connected .....	32
3.3.	Pin Layout.....	33
<b>4.</b>	<b>POWER SUPPLY .....</b>	<b>34</b>
4.1.	Power Supply Requirements.....	34
4.2.	Power Consumption .....	34
4.3.	General Design Rules.....	35
4.3.1.	Electrical Design Guidelines .....	35
4.3.1.1.	+ 5V Input Source Power Supply – Design Guidelines.....	36
4.3.2.	Thermal Design Guidelines.....	36
4.3.3.	Power Supply PCB layout Guidelines .....	37
4.4.	RTC .....	38
4.5.	Reference Voltage .....	38
4.6.	Internal LDO for GNSS bias.....	38
<b>5.</b>	<b>ELECTRICAL SPECIFICATIONS .....</b>	<b>40</b>
5.1.	Absolute Maximum Ratings – Not Operational.....	40
5.2.	Recommended Operating Conditions .....	40
<b>6.</b>	<b>DIGITAL SECTION .....</b>	<b>41</b>
6.1.	Logic Levels.....	41
6.1.1.	1.8V Pins – Absolute Maximum Ratings .....	41
6.1.2.	1.8V Standard GPIOs .....	41
6.1.3.	1.8V SIM Card Pins .....	42
6.1.4.	2.85V Pins – Absolute Maximum Ratings .....	42
6.1.5.	SIM Card Pins @2.85V.....	42
6.2.	Power On.....	43
6.2.1.	Initialization and Activation State .....	43
6.3.	Power Off.....	44
6.3.1.	Graceful Shutdown .....	45
6.3.1.1.	Graceful Shutdown by AT command.....	45
6.3.2.	Fast Shutdown.....	46
6.3.2.1.	Fast Shutdown by AT command .....	46

6.3.2.2.	Fast Shutdown by GPIO .....	47
6.3.3.	Unconditional Shutdown .....	48
6.4.	Reset .....	49
6.4.1.	Graceful Reset.....	50
6.4.2.	Unconditional Hardware Reset .....	50
6.5.	Dying Gasp.....	51
6.6.	Communication ports.....	52
6.6.1.	USB Interface .....	52
6.6.2.	SIM Interface .....	55
6.6.2.1.	SIM Schematic Example.....	56
6.6.3.	Control Signals .....	56
6.6.3.1.	W_DISABLE_N.....	57
6.6.3.2.	WAN_LED_N.....	57
6.6.4.	General Purpose I/O.....	58
6.6.4.1.	Using a GPIO Pin as Input.....	59
6.6.4.2.	Using a GPIO Pin as Output .....	59
6.6.4.3.	Dedicated I/O.....	59
6.6.5.	I2C – Inter-integrated circuit.....	60
6.7.	Using the Temperature Monitor Function.....	61
<b>7.</b>	<b>RF SECTION.....</b>	<b>62</b>
7.1.	Antenna requirements.....	62
7.2.	Primary Antenna Requirements .....	62
7.3.	Secondary Antenna Requirements .....	63
7.4.	GNSS Receiver .....	64
7.4.1.	GNSS RF Front End Design .....	64
7.5.	Antenna connection .....	65
7.5.1.	Support bands on antenna ports.....	65
7.5.2.	Antenna Connector.....	66
7.5.3.	Antenna Cable.....	66
7.5.4.	Antenna Installation Guidelines.....	66
<b>8.</b>	<b>MECHANICAL DESIGN.....</b>	<b>68</b>
8.1.	General.....	68
8.2.	Finishing & Dimensions .....	68
8.3.	Drawing .....	68



<b>9.</b>	<b>APPLICATION GUIDE .....</b>	<b>69</b>
9.1.	Debug of the LM960 Module in Production .....	69
9.2.	Bypass Capacitor on Power Supplies .....	69
9.3.	EMC Recommendations .....	70
<b>10.</b>	<b>PACKAGING.....</b>	<b>73</b>
10.1.	Tray .....	73
<b>11.</b>	<b>CONFORMITY ASSESSMENT ISSUES .....</b>	<b>75</b>
11.1.	Approvals.....	75
11.2.	Declaration of Conformity .....	75
11.3.	FCC certificates .....	75
11.4.	IC certificates.....	75
11.5.	FCC/IC Regulatory notices .....	75
11.6.	RED Regulatory notices.....	78
<b>12.</b>	<b>SAFETY RECOMMENDATIONS.....</b>	<b>80</b>
12.1.	READ CAREFULLY .....	80
<b>13.</b>	<b>REFERENCE TABLE OF RF BANDS CHARACTERISTICS .....</b>	<b>81</b>
<b>14.</b>	<b>ACRONYMS.....</b>	<b>84</b>
<b>15.</b>	<b>DOCUMENT HISTORY .....</b>	<b>86</b>

## 1. INTRODUCTION

### 1.1. Scope

This document introduces the Telit LM960 module and presents possible and recommended hardware solutions for developing a product based on the LM960 module. All the features and solutions detailed in this document are applicable to all LM960 variants, where “LM960” refers to the variants listed in the Applicability Table.

If a specific feature is applicable to a specific product only, it will be clearly marked.



Information – LM960 refers to all modules listed in the Applicability Table.

---

This document takes into account all the basic functions of a wireless module; a valid hardware solution is suggested for each function, and incorrect solutions and common errors to be avoided are pointed out.

Obviously, this document cannot embrace every hardware solution or every product that can be designed. Where the suggested hardware configurations need not be considered mandatory, the information given should be used as a guide and a starting point for properly developing your product with the Telit LM960 module.



Information – The integration of the WCDMA/HSPA+/LTE LM960 cellular module within a user application must be done according to the design rules described in this manual.

---

### 1.2. Audience

This document is intended for Telit customers, especially system integrators, about to implement their applications using the Telit LM960 module.

### 1.3. Contact Information, Support

For general contact, technical support services, technical questions and report documentation errors contact Telit Technical Support at:

- [TS-EMEA@telit.com](mailto:TS-EMEA@telit.com)
- [TS-AMERICAS@telit.com](mailto:TS-AMERICAS@telit.com)

- TS-APAC@telit.com
- TS-SRD@telit.com

For detailed information about where you can buy the Telit modules or for recommendations on accessories and components visit:

<http://www.telit.com>

To register for product news and announcements or for product questions contact Telit's Technical Support Center (TTSC).

Our aim is to make this guide as helpful as possible. Keep us informed of your comments and suggestions for improvements.

Telit appreciates feedback from the users of our information.

## 1.4. Text Conventions

---



Danger – This information **MUST** be followed or catastrophic equipment failure or bodily injury may occur.

---

---



Caution or Warning – Alerts the user to important points about integrating the module, if these points are not followed, the module and end user equipment may fail or malfunction.

---

---



Tip or Information – Provides advice and suggestions that may be useful when integrating the module.

---

All dates are in ISO 8601 format, i.e. YYYY-MM-DD.

## 1.5. Related Documents

- LM960 SW User Guide, 1VV0301477
- LM960 AT Commands Reference Guide, 80568ST10869A
- Generic EVB HW User Guide, 1VV0301249
- LM960 Interface Board HW User Guide, 1VV0301502
- SIM Integration Design Guide Application Note Rev10, 80000NT10001A

## 2. GENERAL PRODUCT DESCRIPTION

### 2.1. Overview

The aim of this document is to present possible and recommended hardware solutions useful for developing a product with the Telit LM960 Mini PCIe module.

In its most basic use case, LM960 can be applied as a wireless communication front-end for mobile products, offering mobile communication features to an external host CPU through its rich interfaces.

LM960 is available in hardware variants as listed in [Applicability Table](#)

The designated RF band sets per each variant are detailed in Section 2.2, [Product Variants and Frequency Bands](#).

### 2.2. Product Variants and Frequency Bands

The operating frequencies in LTE & WCDMA modes conform to the 3GPP specifications.

#### 2.2.1. RF Bands per Regional Variant

This table summarizes RF bands and CA combinations supported on each SW image of LM960/LM960A18 and LM960A9-P.

##### 2.2.1.1. LM960 RF Bands and Carrier Aggregation

AT&T	LTE FDD	LTE TDD	HSPA+
Bands	2, 4, 5, 12, 14, 29(DL), 30, 66	46(DL)	2, 5
AT&T CA combos			
2DL CA	CA_[2A]-[2A], CA_[2A]-[4A], CA_2A-5A, CA_2A-12A, CA_2A-14A, CA_2A-29A, CA_2A-30A, CA_[2A]-46A, CA_[2A]-[66A], CA_2C, CA_[4A]-[4A], CA_4A-5A, CA_4A-12A, CA_4A-29A, CA_4A-30A, CA_[4A]-46A, CA_5A-30A, CA_5A-66A, CA_5B, CA_12A-30A, CA_12A-66A, CA_12B, CA_14A-30A, CA_14A-66A, CA_29A-30A, CA_29A-66A, CA_30A-66A, CA_[66A]-[66A], CA_66B, CA_66C		
3DL CA	CA_2A-2A-5A, CA_[2A]-2A-12A, CA_2A-2A-14A, CA_2A-2A-30A, CA_2A-2A-66A, CA_[2A]-4A-4A, CA_2A-[4A]-[4A], CA_[2A]-4A-5A, CA_2A-[4A]-5A, CA_[2A]-4A-12A, CA_2A-[4A]-12A, CA_2A-4A-30A, CA_2A-5A-30A, CA_[2A]-5A-66A, CA_2A-5A-[66A], CA_2A-12A-30A, CA_[2A]-12A-66A, CA_2A-12A-[66A], CA_2A-14A-30A, CA_2A-14A-66A, CA_2A-29A-30A, CA_2A-30A-66A, CA_2A-46C, CA_2A-66A-66A, CA_[4A]-4A-5A, CA_[4A]-4A-12A, CA_4A-4A-30A, CA_4A-5A-30A, CA_4A-12A-30A, CA_4A-12B, CA_4A-29A-30A, CA_5A-30A-66A, CA_5A-66A-66A, CA_5A-66C, CA_12A-30A-66A, CA_12A-[66A]-66A, CA_14A-30A-66A, CA_14A-66A-66A, CA_29A-30A-66A, CA_29A-66A-66A, CA_30A-66A-66A		

4DL CA	CA_2A-2A-5A-30A, CA_2A-2A-5A-66A, CA_2A-2A-12A-30A, CA_2A-2A-12A-66A, CA_2A-2A-14A-66A, CA_2A-2A-29A-30A, CA_2A-2A-66A-66A, CA_2A-4A-4A-12A, CA_2A-4A-5A-30A, CA_2A-4A-12A-30A, CA_2A-5A-30A-66A, CA_2A-5A-66A-66A, CA_2A-5B-30A, CA_2A-5B-66A, CA_2A-12A-30A-66A, CA_2A-12A-66A-66A, CA_2A-14A-30A-66A, CA_2A-14A-66A-66A, CA_2A-29A-30A-66A, CA_[2A]-46D, CA_[4A]-46D, CA_4A-4A-12A-30A, CA_5A-30A-66A-66A, CA_5B-30A-66A, CA_5B-66A-66A, CA_12A-30A-66A-66A, CA_14A-30A-66A-66A, CA_29A-30A-66A-66A, CA_46D-[66A]		
5DL CA	CA_2A-2A-46D, CA_2A-5B-30A-66A, CA_2A-5B-66A-66A, CA_2A-46D-66A, CA_5B-30A-66A-66A, CA_46D-66A-66A		
2UL CA	CA_2A-5A, CA_2A-12A, CA_4A-12A, CA_5A-66A, CA_5B, CA_12A-66A		
<b>Verizon</b>	<b>LTE FDD</b>	<b>LTE TDD</b>	<b>HSPA+</b>
Bands	2, 4, 5, 13, 66	48	1, 2, 4, 5, 8
<b>Verizon CA combos</b>			
2DL CA	CA_[2A]-[2A], CA_[2A]-[4A], CA_[2A]-5A, CA_[2A]-13A, CA_[2A]-[66A], CA_[4A]-[4A], CA_[4A]-5A, CA_[4A]-13A, CA_5A-[66A], CA_5B, CA_13A-[66A], CA_[66A]-[66A], CA_[66B], CA_[66C], CA_[2A]-48A, CA_13A-48A, CA_48A-[66A]		
3DL CA	CA_[2A]-2A-5A, CA_[2A]-2A-13A, CA_[2A]-2A-66A, CA_2A-2A-[66A], CA_[2A]-4A-5A, CA_2A-[4A]-5A, CA_[2A]-4A-13A, CA_2A-[4A]-13A, CA_[2A]-5A-66A, CA_2A-5A-[66A], CA_[2A]-13A-66A, CA_2A-13A-[66A], CA_[2A]-66A-66A, CA_2A-[66A]-66A, CA_[2A]-[66B], CA_[2A]-[66C], CA_[4A]-4A-5A, CA_[4A]-4A-13A, CA_5A-[66A]-66A, CA_5A-[66B], CA_5A-[66C], CA_13A-[66A]-66A, CA_13A-[66B], CA_13A-[66C], CA_[66A]-[66C], CA_[66D], CA_[2A]-48A-48A, CA_[2A]-48A-66A, CA_2A-48A-[66A], CA_[2A]-48C, CA_13A-48A-48A, CA_13A-48A-[66A], CA_13A-48C, CA_48A-48A-[66A], CA_48A-[66A]-66A, CA_48A-[66B], CA_48C-[66A]		
4DL CA	CA_2A-48A-48A-66A, CA_[2A]-48D, CA_13A-48A-48A-66A, CA_13A-48A-48C, CA_13A-48C-[66A], CA_13A-48D, CA_48A-48A-66A-66A, CA_48A-48A-[66B], CA_48A-48A-[66C], CA_48A-48C-[66A], CA_48D-[66A]		
5DL CA	CA_2A-48E, CA_13A-48A-48C-66A, CA_13A-48C-48C, CA_13A-48D-66A, CA_13A-48E, CA_48A-48C-66B, CA_48A-48C-66C, CA_48C-48C-66A, CA_48E-66A		
2UL CA	CA_2A-13A, CA_4A-13A		
<b>Generic</b>	<b>LTE FDD</b>	<b>LTE TDD</b>	<b>HSPA+</b>
Bands	1, 2, 3, 4, 5, 7, 8, 12, 13, 14, 17, 18, 19, 20, 25, 26, 28, 29(DL), 30, 32, 66, 71	38, 39, 40, 41, 42, 43, 46(DL), 48	1, 2, 4, 5, 8, 9, 19

Generic (EU and rest of world) CA combos	
2DL CA	CA_1A-3A, CA_1A-5A, CA_1A-7A, CA_1A-8A, CA_1A-18A, CA_1A-19A, CA_1A-20A, CA_1A-26A, CA_1A-28A, CA_1A-32A, CA_1A-38A, CA_1A-40A, CA_1A-41A, CA_1A-42A, CA_[2A]-[4A], CA_[2A]-5A, CA_[2A]-7A, CA_[2A]-12A, CA_[2A]-28A, CA_[2A]-46A, CA_[2A]-48A, CA_[2A]-[66A], CA_[2A]-71A, CA_3A-5A, CA_3A-7A, CA_3A-8A, CA_3A-19A, CA_3A-20A, CA_3A-26A, CA_3A-28A, CA_3A-32A, CA_3A-38A, CA_3A-40A, CA_3A-42A, CA_[4A]-5A, CA_4A-7A, CA_[4A]-12A, CA_[4A]-28A, CA_[4A]-46A, CA_5A-7A, CA_7A-8A, CA_7A-12A, CA_7A-20A, CA_7A-28A, CA_7A-42A, CA_8A-38A, CA_8A-40A, CA_8A-42A, CA_12A-[66A], CA_20A-32A, CA_20A-38A, CA_20A-40A, CA_20A-42A, CA_26A-[41A], CA_28A-40A, CA_28A-42A, CA_39A-41A, CA_40A-42A, CA_46A-[66A], CA_48A-[66A], CA_[66A]-71A, CA_1A-1A, CA_[2A]-[2A], CA_3A-3A, CA_[4A]-[4A], CA_7A-7A, CA_40A-40A, CA_42A-42A, CA_48A-48A, CA_[66A]-[66A], CA_[2C], CA_3C, CA_7B, CA_7C, CA_8B, CA_12B, CA_38C, CA_39C, CA_40C, CA_[41C], CA_42C, CA_48C, CA_[66B], CA_[66C]
3DL CA	CA_1A-1A-3A, CA_1A-3A-3A, CA_1A-3A-7A, CA_1A-3A-8A, CA_1A-3A-19A, CA_1A-3A-20A, CA_1A-3A-28A, CA_1A-3A-32A, CA_1A-3A-38A, CA_1A-3A-40A, CA_1A-3A-41A, CA_1A-3A-42A, CA_1A-3C, CA_1A-7A-7A, CA_1A-7A-8A, CA_1A-7A-20A, CA_1A-7A-28A, CA_1A-7A-42A, CA_1A-7C, CA_1A-8A-40A, CA_1A-20A-32A, CA_1A-20A-42A, CA_1A-28A-42A, CA_1A-40C, CA_1A-41C, CA_1A-42C, CA_1A-46C, CA_1C-3A, CA_[2A]-2A-12A, CA_2A-[2A]-12A, CA_[2A]-2A-66A, CA_2A-[2A]-66A, CA_2A-2A-[66A], CA_[2A]-2A-71A, CA_2A-[2A]-71A, CA_[2A]-4A-4A, CA_2A-[4A]-4AC, CA_2A-4A-[4A], CA_[2A]-4A-5A, CA_2A-[4A]-5A, CA_[2A]-4A-12A, CA_2A-[4A]-12A, CA_[2A]-4A-29A, CA_2A-[4A]-29A, CA_[2A]-4A-71A, CA_2A-[4A]-71A, CA_2A-7A-12A, CA_[2A]-12A-66A, CA_2A-12A-[66A], CA_[2A]-12B, CA_[2A]-46A-46A, CA_[2A]-46A-66A, CA_2A-46A-[66A], CA_[2A]-46C, CA_[2A]-48A-48A, CA_[2A]-48C, CA_[2A]-48A-66A, CA_2A-48A-[66A], CA_[2A]-66A-66A, CA_2A-[66A]-66A, CA_2A-66A-[66A], CA_[2A]-66A-71A, CA_2A-[66A]-71A, CA_[2A]-[66C], CA_[2A]-66C, CA_2A-[66C], CA_3A-3A-7A, CA_3A-3A-8A, CA_3A-3A-20A, CA_3A-3A-28A, CA_3C-5A, CA_3A-7A-7A, CA_3A-7A-8A, CA_3A-7A-20A, CA_3A-7A-28A, CA_3A-7A-42A, CA_3A-7B, CA_3A-7C, CA_3C-7A, CA_3A-8A-38A, CA_3A-8A-40A, CA_3C-8A, CA_3A-20A-32A, CA_3A-20A-42A, CA_3A-28A-40A, CA_3A-28A-42A, CA_3C-20A, CA_3C-28A, CA_3A-40A-40A, CA_3A-40C, CA_3A-42A-42A, CA_3A-42C, CA_3A-46C, CA_3C-32A, CA_3C-38A, CA_3C-40A, CA_4A-4A-7A, CA_[4A]-4A-12A, CA_4A-[4A]-12A, CA_[4A]-4A-71A, CA_4A-[4A]-71A, CA_4A-7A-12A, CA_[4A]-12B, CA_[4A]-46A-46A, CA_[4A]-46C, CA_7A-7A-8A, CA_7A-20A-42A, CA_7C-20A, CA_7B-28A, CA_7C-28A, CA_7A-46C, CA_8A-40C, CA_8A-42C, CA_12A-[66A]-66A, CA_12A-66A-[66A], CA_12A-[66C], CA_19A-42C, CA_20A-38C, CA_28A-40C, CA_28A-42C, CA_40A-40C, CA_40D, CA_40A-42C, CA_40C-42A, CA_42A-42C, CA_42D, CA_46C-[66A], CA_48A-48C, CA_48D, CA_48A-48A-[66A], CA_48C-[66A], CA_[66A]-66A-71A, CA_66A-[66A]-71A



4DL CA	CA_1A-1A-3A-28A, CA_1A-3A-3A-28A, CA_1A-3A-7A-7A, CA_1A-3A-7C, CA_1A-3A-7A-8A, CA_1A-3A-7A-20A, CA_1A-3A-7A-28A, CA_1A-3A-8A-40A, CA_1A-3A-3A-8A, CA_1A-3A-40C, CA_1A-3A-42C, CA_1A-3C-5A, CA_1A-3C-7A, CA_1A-3C-8A, CA_1A-3C-28A, CA_1A-7C-28A, CA_1A-42D, CA_1A-46D, CA_2A-2A-12A-66A, CA_2A-2A-66A-66A, CA_2A-2A-66A-71A, CA_[2A]-2A-66C, CA_2A-[2A]-66C, CA_2A-2A-[66C], CA_2A-4A-7A-12A, CA_2A-12A-66A-66A, CA_2A-46A-46A-66A, CA_[2A]-46A-46C, CA_[2A]-46C-66A, CA_2A-46C-[66A], CA_[2A]-46D, CA_[2C]-66A-66A, CA_2C-[66A]-66A, CA_2C-66A-[66A], CA_3A-3A-7A-7A, CA_3A-3A-7A-8A, CA_3A-3A-7A-20A, CA_3A-3A-7A-28A, CA_3A-5A-7A-7A, CA_3A-7A-7A-8A, CA_3A-7C-20A, CA_3A-7C-28A, CA_3A-28A-40C, CA_3A-28A-42C, CA_3A-40D, CA_3A-46D, CA_3C-7A-20A, CA_3C-7A-28A, CA_3C-7C, CA_3C-40C, CA_[4A]-46A-46C, CA_[4A]-46D, CA_7A-46D, CA_28A-40D, CA_28A-46D, CA_40C-40C, CA_40C-42C, CA_40E, CA_[41C]-42C, CA_42C-42C, CA_42E, CA_46A-46C-[66A], CA_46D-[66A], CA_48D-[66A], CA_48E
5DL CA	CA_1A-3A-7C-28A, CA_1A-3C-7C, CA_1A-3C-40C, CA_2A-46A-46C-66A, CA_2A-46D-66A, CA_3A-28A-40D, CA_3C-7C-28A, CA_3A-40E
2UL CA	CA_1A-7A, CA_1A-8A, CA_1A-28A, CA_3A-7A, CA_3A-8A, CA_3A-20A, CA_3A-28A, CA_4A-7A, CA_3C, CA_7C, CA_38C, CA_39C, CA_40C, CA_41C, CA_42C

2.2.1.2. LM960A18 RF Bands and Carrier Aggregation

AT&T	LTE FDD	LTE TDD	HSPA+
Bands	2, 4, 5, 7, 12, 13, 14, 25, 26, 29(DL), 30, 66, 71	41, 46(DL), 48	1, 2, 4, 5, 8
AT&T CA combos			
2DL CA	CA_[2A]-[4A], CA_[2A]-5A, CA_2A-7A, CA_[2A]-12A, CA_[2A]-14A, CA_[2A]-29A, CA_2A-30A, CA_[2A]-46A, CA_[2A]-48A, CA_[2A]-[66A], CA_[2A]-71A, CA_[4A]-5A, CA_4A-7A, CA_[4A]-12A, CA_[4A]-29A, CA_4A-30A, CA_[4A]-46A, CA_[4A]-71A, CA_5A-30A, CA_5A-[66A], CA_7A-12A, CA_12A-30A, CA_12A-[66A], CA_14A-30A, CA_14A-[66A], CA_[25A]-26A, CA_25A-41A, CA_26A-[41A], CA_29A-30A, CA_29A-[66A], CA_30A-66A, CA_46A-[66A], CA_48A-[66A], CA_[66A]-71A, CA_[2A]-[2A], CA_[4A]-[4A], CA_[25A]-[25A], CA_[41A]-[41A], CA_48A-48A, CA_[66A]-[66A], CA_[2C], CA_5B, CA_7C, CA_12B, CA_[41C], CA_48C, CA_[66B], CA_[66C]		

3DL CA	CA_[2A]-2A-5A, CA_2A-[2A]-5A, CA_[2A]-2A-12A, CA_2A-[2A]-12A, CA_2A-2A-30A, CA_[2A]-2A-66A, CA_2A-[2A]-66A, CA_2A-2A-[66A], CA_[2A]-2A-71A, CA_2A-[2A]-71A, CA_[2A]-4A-4A, CA_2A-[4A]-4A, CA_2A-4A-[4A], CA_[2A]-4A-5A, CA_2A-[4A]-5A, CA_[2A]-4A-12A, CA_2A-[4A]-12A, CA_[2A]-4A-29A, CA_2A-[4A]-29A, CA_2A-4A-30A, CA_[2A]-4A-71A, CA_2A-[4A]-71A, CA_2A-5A-30A, CA_[2A]-5A-66A, CA_2A-5A-[66A], CA_2A-7A-12A, CA_2A-12A-30A, CA_[2A]-12A-66A, CA_2A-12A-[66A], CA_[2A]-12B, CA_2A-14A-30A, CA_[2A]-14A-66A, CA_2A-14A-[66A], CA_2A-29A-30A, CA_2A-30A-66A, CA_[2A]-46A-46A, CA_[2A]-46A-66A, CA_2A-46A-[66A], CA_[2A]-46C, CA_[2A]-48A-48A, CA_[2A]-48C, CA_[2A]-48A-66A, CA_2A-48A-[66A], CA_[2A]-66A-66A, CA_2A-[66A]-66A, CA_2A-66A-[66A], CA_[2A]-66A-71A, CA_2A-[66A]-71A, CA_[2A]-[66C], CA_[2A]-66C, CA_2A-[66C], CA_[4A]-4A-5A, CA_4A-[4A]-5A, CA_4A-4A-7A, CA_[4A]-4A-12A, CA_4A-[4A]-12A, CA_4A-4A-30A, CA_[4A]-4A-71A, CA_4A-[4A]-71A, CA_4A-5A-30A, CA_4A-7A-12A, CA_4A-12A-30A, CA_[4A]-12B, CA_4A-29A-30A, CA_[4A]-46A-46A, CA_[4A]-46C, CA_5A-30A-66A, CA_5A-[66A]-66A, CA_5A-66A-[66A], CA_5A-[66C], CA_12A-30A-66A, CA_12A-[66A]-66A, CA_12A-66A-[66A], CA_12A-[66C], CA_14A-30A-66A, CA_14A-[66A]-66A, CA_14A-66A-[66A], CA_[25A]-25A-26A, CA_25A-[25A]-26A, CA_25A-41C, CA_26A-[41C], CA_29A-30A-66A, CA_29A-[66A]-66A, CA_29A-66A-[66A], CA_30A-66A-66A, CA_[41A]-[41C], CA_[41A]-41C, CA_41A-[41C], CA_[41D], CA_46C-[66A], CA_48A-48C, CA_48D, CA_48A-48A-[66A], CA_48C-[66A], CA_[66A]-66A-71A, CA_66A-[66A]-71A		
4DL CA	CA_2A-2A-5A-30A, CA_2A-2A-5A-66A, CA_2A-2A-12A-30A, CA_2A-2A-12A-66A, CA_2A-2A-29A-30A, CA_2A-2A-66A-66A, CA_2A-2A-66A-71A, CA_[2A]-2A-66C, CA_2A-[2A]-66C, CA_2A-2A-[66C], CA_2A-4A-4A-12A, CA_2A-4A-5A-30A, CA_2A-4A-7A-12A, CA_2A-4A-12A-30A, CA_2A-5A-30A-66A, CA_2A-5A-66A-66A, CA_2A-5B-30A, CA_[2A]-5B-66A, CA_2A-5B-[66A], CA_2A-12A-30A-66A, CA_2A-12A-66A-66A, CA_2A-29A-30A-66A, CA_2A-46A-46A-66A, CA_[2A]-46A-46C, CA_[2A]-46C-66A, CA_2A-46C-[66A], CA_[2A]-46D, CA_2A-66A-66A-71A, CA_2A-66C-71A, CA_[2C]-66A-66A, CA_2C-[66A]-66A, CA_2C-66A-[66A], CA_4A-4A-12A-30A, CA_[4A]-46A-46C, CA_[4A]-46D, CA_5A-30A-66A-66A, CA_5B-30A-66A, CA_5B-66A-66A, CA_12A-30A-66A-66A, CA_25A-41D, CA_29A-30A-66A-66A, CA_[41A]-41D, CA_[41C]-41C, CA_41C-[41C], CA_41E, CA_46A-46C-[66A], CA_46D-[66A], CA_48D-[66A], CA_48E		
5DL CA	CA_2A-2A-46D, CA_2A-5B-30A-66A, CA_2A-5B-66A-66A, CA_2A-46A-46C-66A, CA_2A-46D-66A, CA_5B-30A-66A-66A, CA_46D-66A-66A		
2UL CA	CA_2A-5A, CA_2A-12A, CA_4A-12A, CA_5B, CA_41C, CA_5A-66A		
<b>Verizon</b>	<b>LTE FDD</b>	<b>LTE TDD</b>	<b>HSPA+</b>
Bands	2, 4, 5, 13, 66	48	1, 2, 4, 5, 8
<b>Verizon CA combos</b>			
2DL CA	CA_[2A]-[2A], CA_[2A]-[4A], CA_[2A]-5A, CA_[2A]-13A, CA_[2A]-[66A], CA_[4A]-[4A], CA_[4A]-5A, CA_[4A]-13A, CA_5A-[66A], CA_5B, CA_13A-[66A], CA_[66A]-[66A], CA_[66B], CA_[66C], CA_[2A]-48A, CA_13A-48A, CA_48A-[66A]		

3DL CA	CA_[2A]-2A-5A, CA_[2A]-2A-13A, CA_[2A]-2A-66A, CA_2A-2A-[66A], CA_[2A]-4A-5A, CA_2A-[4A]-5A, CA_[2A]-4A-13A, CA_2A-[4A]-13A, CA_[2A]-5A-66A, CA_2A-5A-[66A], CA_[2A]-13A-66A, CA_2A-13A-[66A], CA_[2A]-66A-66A, CA_2A-[66A]-66A, CA_[2A]-[66B], CA_[2A]-[66C], CA_[4A]-4A-5A, CA_[4A]-4A-13A, CA_5A-[66A]-66A, CA_5A-[66B], CA_5A-[66C], CA_13A-[66A]-66A, CA_13A-[66B], CA_13A-[66C], CA_[66A]-[66C], CA_[66D], CA_[2A]-48A-48A, CA_[2A]-48A-66A, CA_2A-48A-[66A], CA_[2A]-48C, CA_13A-48A-48A, CA_13A-48A-[66A], CA_13A-48C, CA_48A-48A-[66A], CA_48A-[66A]-66A, CA_48A-[66B], CA_48C-[66A]		
4DL CA	CA_2A-48A-48A-66A, CA_[2A]-48D, CA_13A-48A-48A-66A, CA_13A-48A-48C, CA_13A-48C-[66A], CA_13A-48D, CA_48A-48A-66A-66A, CA_48A-48A-[66B], CA_48A-48A-[66C], CA_48A-48C-[66A], CA_48D-[66A]		
5DL CA	CA_2A-48E, CA_13A-48A-48C-66A, CA_13A-48C-48C, CA_13A-48D-66A, CA_13A-48E, CA_48A-48C-66B, CA_48A-48C-66C, CA_48C-48C-66A, CA_48E-66A		
2UL CA	CA_2A-13A, CA_4A-13A		
<b>Generic</b>	<b>LTE FDD</b>	<b>LTE TDD</b>	<b>HSPA+</b>
Bands	1, 2, 3, 4, 5, 7, 8, 12, 13, 14, 17, 18, 19, 20, 25, 26, 28, 29(DL), 30, 32, 66, 71	38, 39, 40, 41, 42, 43, 46(DL), 48	1, 2, 4, 5, 8, 9, 19
<b>Generic (EU and rest of world) CA combos</b>			
2DL CA	CA_1A-3A, CA_1A-5A, CA_1A-7A, CA_1A-8A, CA_1A-18A, CA_1A-19A, CA_1A-20A, CA_1A-26A, CA_1A-28A, CA_1A-32A, CA_1A-38A, CA_1A-40A, CA_1A-41A, CA_1A-42A, CA_[2A]-[4A], CA_[2A]-5A, CA_[2A]-7A, CA_[2A]-12A, CA_[2A]-28A, CA_[2A]-46A, CA_[2A]-48A, CA_[2A]-[66A], CA_[2A]-71A, CA_3A-5A, CA_3A-7A, CA_3A-8A, CA_3A-19A, CA_3A-20A, CA_3A-26A, CA_3A-28A, CA_3A-32A, CA_3A-38A, CA_3A-40A, CA_3A-42A, CA_[4A]-5A, CA_4A-7A, CA_[4A]-12A, CA_[4A]-28A, CA_[4A]-46A, CA_5A-7A, CA_7A-8A, CA_7A-12A, CA_7A-20A, CA_7A-28A, CA_7A-42A, CA_8A-38A, CA_8A-40A, CA_8A-42A, CA_12A-[66A], CA_20A-32A, CA_20A-38A, CA_20A-40A, CA_20A-42A, CA_26A-[41A], CA_28A-40A, CA_28A-42A, CA_39A-41A, CA_40A-42A, CA_46A-[66A], CA_48A-[66A], CA_[66A]-71A, CA_1A-1A, CA_[2A]-[2A], CA_3A-3A, CA_[4A]-[4A], CA_7A-7A, CA_40A-40A, CA_42A-42A, CA_48A-48A, CA_[66A]-[66A], CA_[2C], CA_3C, CA_7B, CA_7C, CA_8B, CA_12B, CA_38C, CA_39C, CA_40C, CA_[41C], CA_42C, CA_48C, CA_[66B], CA_[66C]		

3DL CA	CA_1A-1A-3A, CA_1A-3A-3A, CA_1A-3A-7A, CA_1A-3A-8A, CA_1A-3A-19A, CA_1A-3A-20A, CA_1A-3A-28A, CA_1A-3A-32A, CA_1A-3A-38A, CA_1A-3A-40A, CA_1A-3A-41A, CA_1A-3A-42A, CA_1A-3C, CA_1A-7A-7A, CA_1A-7A-8A, CA_1A-7A-20A, CA_1A-7A-28A, CA_1A-7A-42A, CA_1A-7C, CA_1A-8A-40A, CA_1A-20A-32A, CA_1A-20A-42A, CA_1A-28A-42A, CA_1A-40C, CA_1A-41C, CA_1A-42C, CA_1A-46C, CA_1C-3A, CA_[2A]-2A-12A, CA_2A-[2A]-12A, CA_[2A]-2A-66A, CA_2A-[2A]-66A, CA_2A-2A-[66A], CA_[2A]-2A-71A, CA_2A-[2A]-71A, CA_[2A]-4A-4A, CA_2A-[4A]-4AC, CA_2A-4A-[4A], CA_[2A]-4A-5A, CA_2A-[4A]-5A, CA_[2A]-4A-12A, CA_2A-[4A]-12A, CA_[2A]-4A-29A, CA_2A-[4A]-29A, CA_[2A]-4A-71A, CA_2A-[4A]-71A, CA_2A-7A-12A, CA_[2A]-12A-66A, CA_2A-12A-[66A], CA_[2A]-12B, CA_[2A]-46A-46A, CA_[2A]-46A-66A, CA_2A-46A-[66A], CA_[2A]-46C, CA_[2A]-48A-48A, CA_[2A]-48C, CA_[2A]-48A-66A, CA_2A-48A-[66A], CA_[2A]-66A-66A, CA_2A-[66A]-66A, CA_2A-66A-[66A], CA_[2A]-66A-71A, CA_2A-[66A]-71A, CA_[2A]-[66C], CA_[2A]-66C, CA_2A-[66C], CA_3A-3A-7A, CA_3A-3A-8A, CA_3A-3A-20A, CA_3A-3A-28A, CA_3C-5A, CA_3A-7A-7A, CA_3A-7A-8A, CA_3A-7A-20A, CA_3A-7A-28A, CA_3A-7A-42A, CA_3A-7B, CA_3A-7C, CA_3C-7A, CA_3A-8A-38A, CA_3A-8A-40A, CA_3C-8A, CA_3A-20A-32A, CA_3A-20A-42A, CA_3A-28A-40A, CA_3A-28A-42A, CA_3C-20A, CA_3C-28A, CA_3A-40A-40A, CA_3A-40C, CA_3A-42A-42A, CA_3A-42C, CA_3A-46C, CA_3C-32A, CA_3C-38A, CA_3C-40A, CA_4A-4A-7A, CA_[4A]-4A-12A, CA_4A-[4A]-12A, CA_[4A]-4A-71A, CA_4A-[4A]-71A, CA_4A-7A-12A, CA_[4A]-12B, CA_[4A]-46A-46A, CA_[4A]-46C, CA_7A-7A-8A, CA_7A-20A-42A, CA_7C-20A, CA_7B-28A, CA_7C-28A, CA_7A-46C, CA_8A-40C, CA_8A-42C, CA_12A-[66A]-66A, CA_12A-66A-[66A], CA_12A-[66C], CA_19A-42C, CA_20A-38C, CA_28A-40C, CA_28A-42C, CA_40A-40C, CA_40D, CA_40A-42C, CA_40C-42A, CA_42A-42C, CA_42D, CA_46C-[66A], CA_48A-48C, CA_48D, CA_48A-48A-[66A], CA_48C-[66A], CA_[66A]-66A-71A, CA_66A-[66A]-71A		
4DL CA	CA_1A-1A-3A-28A, CA_1A-3A-3A-28A, CA_1A-3A-7A-7A, CA_1A-3A-7C, CA_1A-3A-7A-8A, CA_1A-3A-7A-20A, CA_1A-3A-7A-28A, CA_1A-3A-8A-40A, CA_1A-3A-3A-8A, CA_1A-3A-40C, CA_1A-3A-42C, CA_1A-3C-5A, CA_1A-3C-7A, CA_1A-3C-8A, CA_1A-3C-28A, CA_1A-7C-28A, CA_1A-42D, CA_1A-46D, CA_2A-2A-12A-66A, CA_2A-2A-66A-66A, CA_2A-2A-66A-71A, CA_[2A]-2A-66C, CA_2A-[2A]-66C, CA_2A-2A-[66C], CA_2A-4A-7A-12A, CA_2A-12A-66A-66A, CA_2A-46A-46A-66A, CA_[2A]-46A-46C, CA_[2A]-46C-66A, CA_2A-46C-[66A], CA_[2A]-46D, CA_[2C]-66A-66A, CA_2C-[66A]-66A, CA_2C-66A-[66A], CA_3A-3A-7A-7A, CA_3A-3A-7A-8A, CA_3A-3A-7A-20A, CA_3A-3A-7A-28A, CA_3A-5A-7A-7A, CA_3A-7A-7A-8A, CA_3A-7C-20A, CA_3A-7C-28A, CA_3A-28A-40C, CA_3A-28A-42C, CA_3A-40D, CA_3A-46D, CA_3C-7A-20A, CA_3C-7A-28A, CA_3C-7C, CA_3C-40C, CA_[4A]-46A-46C, CA_[4A]-46D, CA_7A-46D, CA_28A-40D, CA_28A-46D, CA_40C-40C, CA_40C-42C, CA_40E, CA_[41C]-42C, CA_42C-42C, CA_42E, CA_46A-46C-[66A], CA_46D-[66A], CA_48D-[66A], CA_48E		
5DL CA	CA_1A-3A-7C-28A, CA_1A-3C-7C, CA_1A-3C-40C, CA_2A-46A-46C-66A, CA_2A-46D-66A, CA_3A-28A-40D, CA_3C-7C-28A, CA_3A-40E		
2UL CA	CA_1A-7A, CA_1A-8A, CA_1A-28A, CA_3A-7A, CA_3A-8A, CA_3A-20A, CA_3A-28A, CA_4A-7A, CA_3C, CA_7C, CA_38C, CA_39C, CA_40C, CA_41C, CA_42C		
<b>T-Mobile</b>	<b>LTE FDD</b>	<b>LTE TDD</b>	<b>HSPA+</b>
Bands	2, 4, 5, 7, 12, 13, 14, 25, 26, 29(DL), 30, 66, 71	41, 46(DL), 48	1, 2, 4, 5, 8

T-Mobile CA combos		
2DL CA	CA_[2A]-[4A], CA_[2A]-5A, CA_2A-7A, CA_[2A]-12A, CA_[2A]-14A, CA_[2A]-29A, CA_2A-30A, CA_[2A]-46A, CA_[2A]-48A, CA_[2A]-[66A], CA_[2A]-71A, CA_[4A]-5A, CA_4A-7A, CA_[4A]-12A, CA_[4A]-29A, CA_4A-30A, CA_[4A]-46A, CA_[4A]-71A, CA_5A-30A, CA_5A-[66A], CA_7A-12A, CA_12A-30A, CA_12A-[66A], CA_14A-30A, CA_14A-[66A], CA_[25A]-26A, CA_25A-41A, CA_26A-[41A], CA_29A-30A, CA_29A-[66A], CA_30A-66A, CA_46A-[66A], CA_48A-[66A], CA_[66A]-71A, CA_[2A]-[2A], CA_[4A]-[4A], CA_[25A]-[25A], CA_[41A]-[41A], CA_48A-48A, CA_[66A]-[66A], CA_[2C], CA_5B, CA_7C, CA_12B, CA_[41C], CA_48C, CA_[66B], CA_[66C]	
3DL CA	CA_[2A]-2A-5A, CA_2A-[2A]-5A, CA_[2A]-2A-12A, CA_2A-[2A]-12A, CA_2A-2A-30A, CA_[2A]-2A-66A, CA_2A-[2A]-66A, CA_2A-2A-[66A], CA_[2A]-2A-71A, CA_2A-[2A]-71A, CA_[2A]-4A-4A, CA_2A-[4A]-4A, CA_2A-4A-[4A], CA_[2A]-4A-5A, CA_2A-[4A]-5A, CA_[2A]-4A-12A, CA_2A-[4A]-12A, CA_[2A]-4A-29A, CA_2A-[4A]-29A, CA_2A-4A-30A, CA_[2A]-4A-71A, CA_2A-[4A]-71A, CA_2A-5A-30A, CA_[2A]-5A-66A, CA_2A-5A-[66A], CA_2A-7A-12A, CA_2A-12A-30A, CA_[2A]-12A-66A, CA_2A-12A-[66A], CA_[2A]-12B, CA_2A-14A-30A, CA_[2A]-14A-66A, CA_2A-14A-[66A], CA_2A-29A-30A, CA_2A-30A-66A, CA_[2A]-46A-46A, CA_[2A]-46A-66A, CA_2A-46A-[66A], CA_[2A]-46C, CA_[2A]-48A-48A, CA_[2A]-48C, CA_[2A]-48A-66A, CA_2A-48A-[66A], CA_[2A]-66A-66A, CA_2A-[66A]-66A, CA_2A-66A-[66A], CA_[2A]-66A-71A, CA_2A-[66A]-71A, CA_[2A]-[66C], CA_[2A]-66C, CA_2A-[66C], CA_[4A]-4A-5A, CA_4A-[4A]-5A, CA_4A-4A-7A, CA_[4A]-4A-12A, CA_4A-[4A]-12A, CA_4A-4A-30A, CA_[4A]-4A-71A, CA_4A-[4A]-71A, CA_4A-5A-30A, CA_4A-7A-12A, CA_4A-12A-30A, CA_[4A]-12B, CA_4A-29A-30A, CA_[4A]-46A-46A, CA_[4A]-46C, CA_5A-30A-66A, CA_5A-[66A]-66A, CA_5A-66A-[66A], CA_5A-[66C], CA_12A-30A-66A, CA_12A-[66A]-66A, CA_12A-66A-[66A], CA_12A-[66C], CA_14A-30A-66A, CA_14A-[66A]-66A, CA_14A-66A-[66A], CA_[25A]-25A-26A, CA_25A-[25A]-26A, CA_25A-41C, CA_26A-[41C], CA_29A-30A-66A, CA_29A-[66A]-66A, CA_29A-66A-[66A], CA_30A-66A-66A, CA_[41A]-[41C], CA_[41A]-41C, CA_41A-[41C], CA_[41D], CA_46C-[66A], CA_48A-48C, CA_48D, CA_48A-48A-[66A], CA_48C-[66A], CA_[66A]-66A-71A, CA_66A-[66A]-71A	
4DL CA	CA_2A-2A-5A-30A, CA_2A-2A-5A-66A, CA_2A-2A-12A-30A, CA_2A-2A-12A-66A, CA_2A-2A-29A-30A, CA_2A-2A-66A-66A, CA_2A-2A-66A-71A, CA_[2A]-2A-66C, CA_2A-[2A]-66C, CA_2A-2A-[66C], CA_2A-4A-4A-12A, CA_2A-4A-5A-30A, CA_2A-4A-7A-12A, CA_2A-4A-12A-30A, CA_2A-5A-30A-66A, CA_2A-5A-66A-66A, CA_2A-5B-30A, CA_[2A]-5B-66A, CA_2A-5B-[66A], CA_2A-12A-30A-66A, CA_2A-12A-66A-66A, CA_2A-29A-30A-66A, CA_2A-46A-46A-66A, CA_[2A]-46A-46C, CA_[2A]-46C-66A, CA_2A-46C-[66A], CA_[2A]-46D, CA_2A-66A-66A-71A, CA_2A-66C-71A, CA_[2C]-66A-66A, CA_2C-[66A]-66A, CA_2C-66A-[66A], CA_4A-4A-12A-30A, CA_[4A]-46A-46C, CA_[4A]-46D, CA_5A-30A-66A-66A, CA_5B-30A-66A, CA_5B-66A-66A, CA_12A-30A-66A-66A, CA_25A-41D, CA_29A-30A-66A-66A, CA_[41A]-41D, CA_[41C]-41C, CA_41C-[41C], CA_41E, CA_46A-46C-[66A], CA_46D-[66A], CA_48D-[66A], CA_48E	
5DL CA	CA_2A-2A-46D, CA_2A-5B-30A-66A, CA_2A-5B-66A-66A, CA_2A-46A-46C-66A, CA_2A-46D-66A, CA_5B-30A-66A-66A, CA_46D-66A-66A	
2UL CA	CA_2A-5A, CA_2A-12A, CA_4A-12A, CA_5B, CA_41C, CA_5A-66A	
<b>Sprint</b>	<b>LTE TDD</b>	<b>HSPA+</b>
Bands	2, 4, 5, 7, 12, 13, 25, 26	41

Sprint CA combos	
2DL CA	CA_[25A]-[25A], CA_[25A]-26A, CA_25A-41A, CA_26A-[41A], CA_[41A]-[41A], CA_[41C]
3DL CA	CA_[25A]-25A-26A, CA_26A-[41C], CA_[41A]-[41C], CA_[41D], CA_25A-41C
4DL CA	CA_25A-41D, CA_[41C]-41C, CA_[41A]-41D, CA_41E
2UL CA	CA_41C

### 2.2.1.3. LM960A9-P RF Bands and Carrier Aggregation

CBRS	LTE FDD	LTE TDD	HSPA+
Bands		42, 43, 48	
CBRS CA combos			
2DL CA	CA_48A-48A, CA_42C, CA_48C		
3DL CA	CA_42A-42C, CA_42D, CA_48A-48C, CA_48D		

- [ ] means that 4\*4 MIMO is supported
- LM960 and LM960A18 share the same HW version, with differences concerning supported bands and CA combos according to regional variant

Please refer to Chapter 13 for details information about frequencies and bands.

## 2.3. Target market

LM960 can be used for applications where very high bandwidth, extensive band coverage and multiple network carriers certification in a single SKU are required, such as:

- Industrial equipment
- Internet connectivity devices (mobile routers, access points)

## 2.4. Main features

The LM960 family of industrial grade cellular modules features LTE and multi-RAT module together.

Main functions and features are listed below:

### Main Features

Function	Features
<b>Module</b>	<p>Cellular module for data communication</p> <ul style="list-style-type: none"> <li>• LM960/LM960A18 <ul style="list-style-type: none"> <li>○ LTE FDD/TDD Cat18(DL)/13(UL) (1.2 Gbps/150 Mbps)</li> <li>○ WCDMA up to DC HSPA+, Rel.10</li> </ul> </li> <li>• LM960A9-P <ul style="list-style-type: none"> <li>○ LTE TDD Cat9(DL)/5(UL) (450 Mbps/75 Mbps)</li> </ul> </li> <li>• Support for GPS, GLONASS, BeiDou and Galileo</li> </ul>
<b>Two USIM ports – dual voltage</b>	<ul style="list-style-type: none"> <li>• Support for two SIM interfaces</li> <li>• Class B and Class C support</li> <li>• Clock rates up to 4 MHz</li> </ul>
<b>Application processor</b>	<p>Application processor 32 bit ARM Cortex-A7 up to 1.4 GHz running Linux operating system</p> <ul style="list-style-type: none"> <li>• 4Gbit NAND Flash + 2Gbit LPDDR2 MCP</li> </ul>
<b>Interfaces</b>	<p>Rich set of interfaces, including:</p> <ul style="list-style-type: none"> <li>• USB3.0 – USB port is typically used for: <ul style="list-style-type: none"> <li>○ Flashing of firmware and module configuration</li> <li>○ Production testing</li> <li>○ Accessing the Application Processor's file system</li> <li>○ AT command access</li> <li>○ High-speed WWAN access to external host</li> <li>○ Diagnostic monitoring and debugging</li> <li>○ Communication between Java application environment and an external host CPU</li> <li>○ NMEA data to an external host CPU</li> </ul> </li> <li>• Peripheral Ports – GPIOs</li> </ul>
<b>Major software features</b>	<ul style="list-style-type: none"> <li>• Advanced security features <ul style="list-style-type: none"> <li>○ Boot integrity of firmware up to customer applications</li> <li>○ Disable/secure re-enable of debug</li> <li>○ Embedded security</li> </ul> </li> <li>• FOTA (optional)</li> <li>• Telit Unified AT command set</li> </ul>

Function	Features
<b>Form factor</b>	Mini PCIe Form factor (50.95x30x2.7mm), supporting multiple RF bands
<b>Environment and quality requirements</b>	The device is designed and qualified by Telit to satisfy environmental and quality requirements.
<b>Single supply module</b>	The module internally generates all its required internal supply voltages.
<b>RTC</b>	Real-time clock is supported.
<b>Operating temperature</b>	Range -40 °C to +85 °C (conditions as defined in Section <a href="#">2.9.1, Temperature Range</a> )



## 2.5. Block Diagram

Below figure shows an overview of the internal architecture of the LM960 module.

**LM960 Block Diagram**

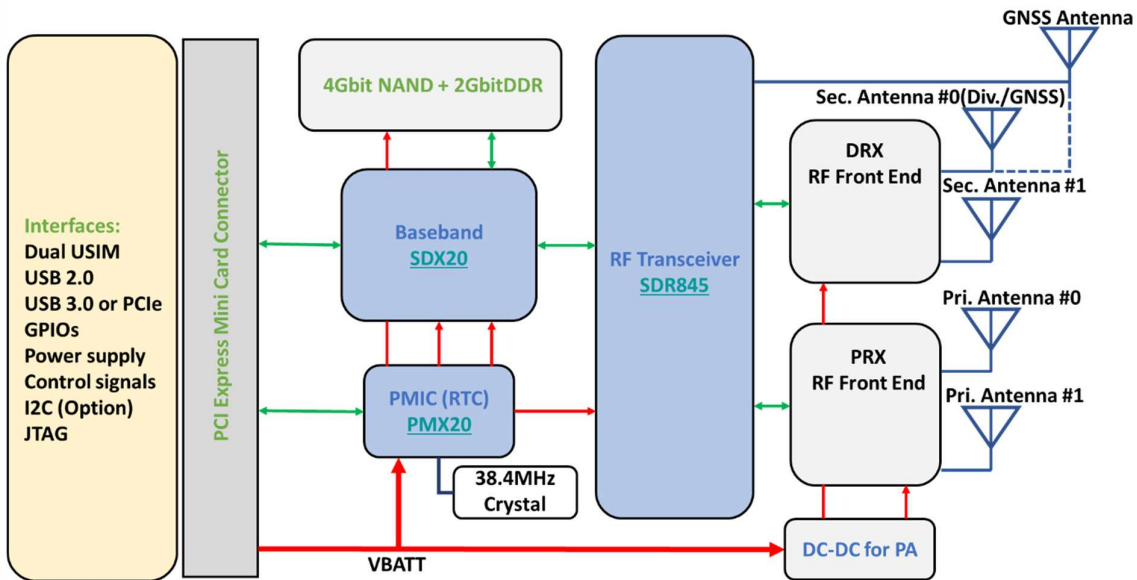

It includes the following sub-functions:

- Application processor, Module subsystem and Location processing with their external interfaces. These three functions are contained in a single SOC.
- RF front end
- Rich IO interfaces. Depending on which LM960 software features are enabled, some of its interfaces that are exported through multiplexing may be used internally and thus may not be usable by the application.
- PMIC with the RTC function inside

## 2.6. TX Output Power

Band	Power class
3G WCDMA	Class 3 (0.2W)
LTE All Bands	Class 3 (0.2W)
LTE Band 41 supports HPUE	Class 2 (0.4W)

## 2.7. RX Sensitivity

Below the 3GPP measurement conditions used to define the RX sensitivity:

Technology	3GPP Compliance
4G LTE	Throughput >95% 10MHz Dual Receiver
3G WCDMA	BER <0.1% 12.2 Kbps Dual Receiver

Product	Band	Typical Rx Sensitivity (dBm) * / ** (BW = 10 MHz / B46 BW = 20 MHz)
LM960	LTE FDD B1	-100.0 dBm
	LTE FDD B2	-100.0 dBm
	LTE FDD B3	-100.0 dBm
	LTE FDD B4	-100.5 dBm
	LTE FDD B5	-101.0 dBm
	LTE FDD B7	-100.0 dBm
	LTE FDD B8	-100.5 dBm
	LTE FDD B12	-101.0 dBm
	LTE FDD B13	-100.5 dBm
	LTE FDD B14	-100.0 dBm
	LTE FDD B17	-101.0 dBm
	LTE FDD B18	-101.0 dBm
	LTE FDD B19	-100.0 dBm
	LTE FDD B20	-100.5 dBm
	LTE FDD B25	-100.0 dBm
	LTE FDD B26	-100.0 dBm
	LTE FDD B28	-100.5 dBm
	LTE FDD B29 (DL Only)	-100.0 dBm
	LTE FDD B30	-100.0 dBm
	LTE FDD B32	-100.0 dBm
	LTE FDD B66	-100.0 dBm
	LTE TDD B38	-99.0 dBm
	LTE TDD B39	-100.0 dBm
	LTE TDD B40	-100.0 dBm
	LTE TDD B41	-99.0 dBm
	LTE TDD B42	-100.0 dBm
	LTE TDD B43	-99.0 dBm
	LTE TDD B46 (DL Only)	-95.0 dBm
	LTE TDD B48	-100.0 dBm

	LTE FDD B71	-99.5 dBm
<b>LM960</b>	WCDMA FDD B1	-111.0 dBm
	WCDMA FDD B2	-110.0 dBm
	WCDMA FDD B4	-111.0 dBm
	WCDMA FDD B5	-111.0 dBm
	WCDMA FDD B8	-110.0 dBm
	WCDMA FDD B9	-110.0 dBm
	WCDMA FDD B19	-111.0 dBm

\* LTE Rx Sensitivity shall be verified by using both (all) antenna ports simultaneously.

\*\* 3.3 Voltage / Room temperature

## 2.8. Mechanical specifications

### 2.8.1. Dimensions

LM960 module overall dimensions are:

- Length: 50.95 mm, +/- 0.15 mm tolerance
- Width: 30.00 mm, +/- 0.15 mm tolerance
- Thickness: 2.70 mm, +/- 0.15 mm tolerance

### 2.8.2. Weight

#### 2.8.2.1. LM960/LM960A18

The nominal weight of the LM960 module is 10.1 grams.

#### 2.8.2.2. LM960A9-P

The nominal weight of the LM960 module is 9.7 grams.

## 2.9. Environmental Requirements

### 2.9.1. Temperature Range

Note		
<b>Operating Temperature Range</b>	-20°C ~ +55°C	This range is defined by 3GPP (the global standard for wireless mobile communication). Telit guarantees its modules to comply with all 3GPP requirements and to have full functionality of the module with in this range.
	-40°C ~ +85°C	Telit guarantees full functionality within this range as well. However, there may possibly be some performance deviations in this extended range relative to 3GPP requirements, which means that some RF

Note	
	<p>parameters may deviate from the 3GPP specification in the order of a few dB. For example: receiver sensitivity or maximum output power may be slightly degraded. Even so, all the functionalities, such as call connection, SMS, USB communication, UART activation etc., will be maintained, and the effect of such degradations will not lead to malfunction.</p>
<b>Storage and non-operating Temperature Range</b>	-40°C ~ +85°C

### 2.9.2. RoHS Compliance

As a part of the Telit corporate policy of environmental protection, the LM960 complies with the RoHS (Restriction of Hazardous Substances) directive of the European Union (EU directive 2011/65/EU).

### 3. PINS ALLOCATION

#### 3.1. Pin-out

##### LM960 Pin-out

Pin	Signal	I/O	Function	Type	Comment
<b>USB HS 2.0 Communication Port</b>					
38	USB_D+	I/O	USB 2.0 Data Plus	Analog	
36	USB_D-	I/O	USB 2.0 Data Minus	Analog	
<b>USB SS 3.0 Communication</b>					
25	USB_TX_P	O	USB 3.0 super-speed	Analog	
23	USB_TX_M	O	USB 3.0 super-speed	Analog	
33	USB_RX_P	I	USB 3.0 super-speed	Analog	
31	USB_RX_M	I	USB 3.0 super-speed	Analog	
<b>Reserved for future use</b>					
7	Reserved	-	-		
11	Reserved	-	-		
13	Reserved	-	-		
22	Reserved	-	-		
<b>SIM Card Interface 1</b>					
8	SIMVCC1	O	Supply output for an external UIM1 card	1.8V / 2.85V	Power
10	SIMIO1	I/O	Data connection with an external UIM1 card	1.8V / 2.85V	
12	SIMCLK1	O	Clock output to an external UIM1 card	1.8V / 2.85V	
14	SIMRST1	O	Reset output to an external UIM1 card	1.8V / 2.85V	
<b>SIM Card Interface 2</b>					
16	SIMVCC2	O	Supply output for an external UIM2 card	1.8 / 2.85V	Power

19	SIMIO2	I/O	Data connection with an external UIM2 card	1.8 / 2.85V	
17	SIMCLK2	O	Clock output to an external UIM2 card	1.8 / 2.85V	
6	SIMRST2	O	Reset output to an external UIM2 card	1.8 / 2.85V	
<b>Digital I/O (GPIOs)</b>					
3	GPIO_01	I/O	General purpose I/O Can be used as SIMIN1	1.8V	
5	GPIO_02	I/O	General purpose I/O Can be used as SIMIN2	1.8V	
44	GPIO_03	I/O	General purpose I/O	1.8V	
46	GPIO_04	I/O	General purpose I/O	1.8V	
45	GPIO_05	I/O	General purpose I/O	1.8V	
47	GPIO_06	I/O	General purpose I/O	1.8V	
49	GPIO_07	I/O	General purpose I/O	1.8V	
51	GPIO_08	I/O	General purpose I/O	1.8V	
<b>Control Signal</b>					
1	Reserved	-	-		
20	W_DISABLE_N	I	RF disable	Open-drain	Internal VBATT Pull-up
42	WAN_LED_N	O	LED control	Open-drain	
<b>Miscellaneous Functions</b>					
28	VREG_L6_1P8	O	Reference Voltage	1.8V	Power
48	SYSTEM_RESET_N	I	Reset Input	1.8V	
<b>I2C Interface</b>					
30	I2C_SCL	O	I2C Clock	1.8V	
32	I2C_SDA	I/O	I2C Data	1.8V	

Power Supply				
2	VBATT	I	Power supply	Power
24	VBATT	I	Power supply	Power
39	VBATT	I	Power supply	Power
41	VBATT	I	Power supply	Power
52	VBATT	I	Power supply	Power
GROUND				
4	GND	-	Ground	Ground
9	GND	-	Ground	Ground
15	GND	-	Ground	Ground
18	GND	-	Ground	Ground
21	GND	-	Ground	Ground
26	GND	-	Ground	Ground
27	GND	-	Ground	Ground
29	GND	-	Ground	Ground
34	GND	-	Ground	Ground
35	GND	-	Ground	Ground
37	GND	-	Ground	Ground
40	GND	-	Ground	Ground
43	GND	-	Ground	Ground
50	GND	-	Ground	Ground



Information – If I2C interface are not used, the signals can be left floating.



Information – Unless otherwise specified, RESERVED pins must be left unconnected (Floating).



Information – PCIe bus is **NOT** supported

### 3.2. LM960 Signals That Must Be Connected

Below table specifies the LM960 signals that must be connected for debugging purposes, even if not used by the end application:

#### Mandatory Signals

Pin	Signal	Notes
2, 24, 39, 41, 52	VBATT	
4, 9, 15, 18, 21, 26, 27, 29, 34, 35, 37, 40, 43, 50	GND	
38	USB_D+	If not used, connect to a test point or an USB connector
36	USB_D-	If not used, connect to a test point or an USB connector



### 3.3. Pin Layout

#### LM960 Pin Layout

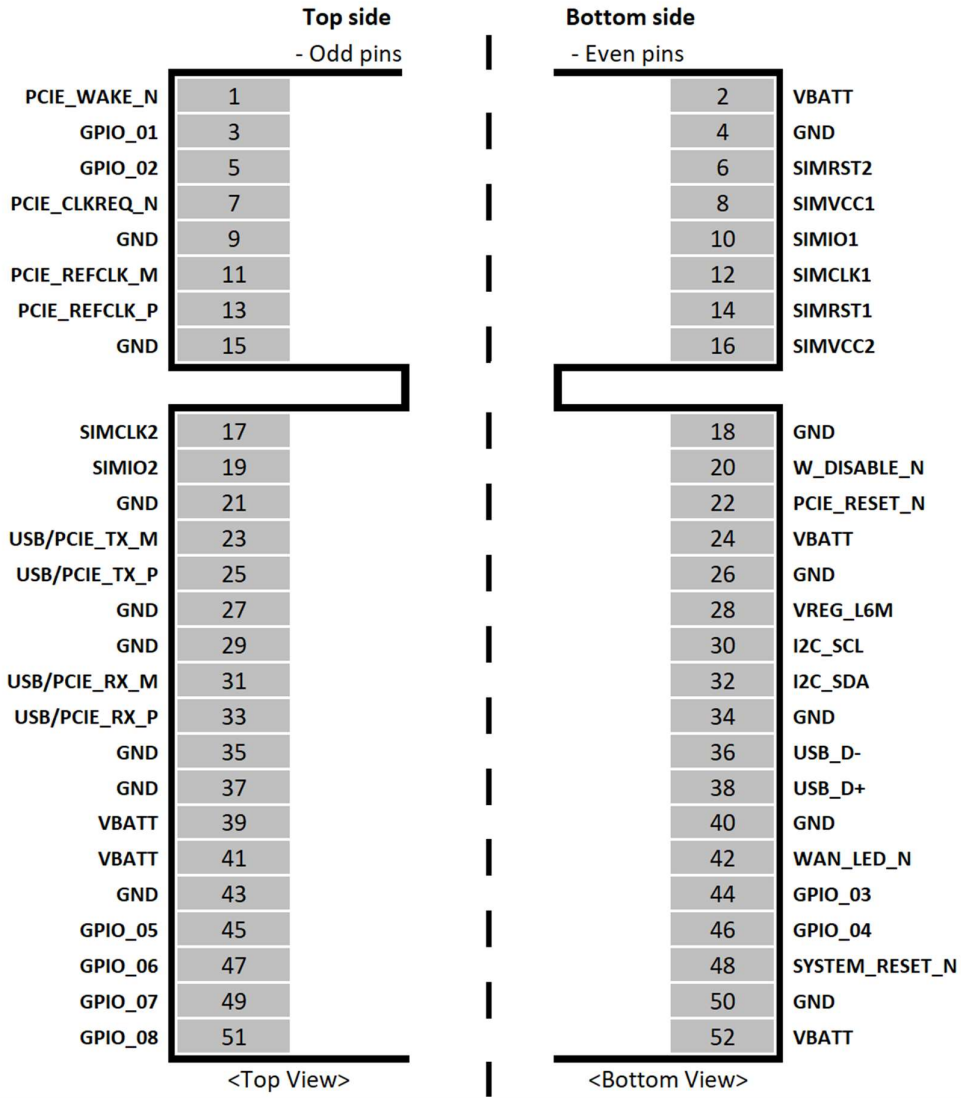

## 4. POWER SUPPLY

The power supply circuitry and board layout are very important components of the full product design, with critical impact on the overall product performance. Read the following requirements and guidelines carefully to ensure a good and proper design.

### 4.1. Power Supply Requirements

The LM960 power requirements are as follows:

#### Power Supply Requirements

Nominal supply voltage	3.3V
Supply voltage range	3.10V – 3.6V
Maximum ripple on module input supply	30 mV

### 4.2. Power Consumption

Below table provides typical current consumption values of LM960 for various operation modes.

#### LM960 and LM960A18 Current Consumption

Mode	Average [Typ.]	Mode Description
<b>IDLE Mode</b>		
CFUN=1	20mA	No call connection USB3.0 is connected to a host
<b>Power Saving Mode (PSMWDISACFG=1, W_DISABLE_N:Low)</b>		
CFUN=4	2.5mA	Tx and Rx are disabled; module is not registered on the network (Flight mode)
WCDMA	3mA	DRx7 (1.28 sec DRx cycle)
LTE	3.3mA	Paging cycle #128 frames (1.28 sec DRx cycle)
<b>Operative Mode (LTE)</b>		
Non-CA mode (1DL / 1UL)	600mA	Non-CA, Band 2, Single carrier, BW 5MHz, 23dBm, 1RB

Mode	Average [Typ.]	Mode Description
2DL CA with 2x2 MIMO / 2UL CA	900mA	CA_2A-5A, 2x2 MIMO, Full RB, 256QAM DL / 64QAM UL (FDD 300Mbps DL / 150Mbps UL)
5DL CA with 2x2 MIMO / 1UL	1000mA	CA_2A-5B-66A-66A, 2x2 MIMO, Full RB, 256QAM DL / 64QAM UL (FDD 1Gbps DL / 75Mbps UL)
3DL CA with 4x4 MIMO / 1UL	1200mA	CA_2A-66C, 4x4 MIMO, Full RB, 256QAM DL / 64QAM UL (FDD 1.2Gbps DL / 75Mbps UL)
<b>Operative Mode (WCDMA)</b>		
WCDMA Voice	750 mA	WCDMA voice call (Tx = 23 dBm)
WCDMA HSPA (22 dBm)	650 mA	WCDMA data call (DC-HSDPA up to 42 Mbps, Max Throughput)

\* Worst/best case current values depend on network configuration - not under module control.

\*\* Loop-back mode in call equipment

\*\*\* 3.3 V voltage / room temperature



Information – The electrical design for the power supply must ensure a peak current output of at least 2A.

### 4.3. General Design Rules

The principal guidelines for the Power Supply Design embrace three different design steps:

- Electrical design
- Thermal design
- PCB layout

#### 4.3.1. Electrical Design Guidelines

The electrical design of the power supply strongly depends on the power source from which power is drained.

#### 4.3.1.1. + 5V Input Source Power Supply – Design Guidelines

- The desired output for the power supply is 3.3V. Being the difference between the input source and the desired output moderate, a linear regulator can be used. A switching power supply is preferred to reduce power consumption.
- When using a linear regulator, a proper heat sink must be provided to dissipate the power generated.
- A bypass low ESR capacitor of adequate capacity must be provided to cut the current absorption peaks close to the LM960 module. A 100  $\mu$ F tantalum capacitor is usually suitable on VBATT.
- Make sure that the low ESR capacitor on the power supply output (usually a tantalum one) is rated at least 10V.
- A protection diode must be inserted close to the power input to protect the LM960 module from power polarity inversion.

#### 4.3.2. Thermal Design Guidelines

The thermal design for the power supply heat sink must be done with the following specifications:

- Average current consumption during RF transmission @PWR level max in LM960 as shown in Section 4.2, Power Consumption table.



Information – The average consumption during transmission depends on the power level at which the device is requested to transmit via the network.

Therefore, the average current consumption varies significantly.

---



Information – The thermal design for the power supply must be made keeping an average consumption at the maximum transmitting level during calls of LTE/HSPA.

---

Considering the very low current during Idle, especially if the Power Saving function is enabled, it is possible to consider from the thermal point of view that the device absorbs significant current only during Data transfer sessions.

In LTE/WCDMA/HSPA mode, the LM960 emits RF signals continuously during transmission. Therefore, special attention must be paid on how to dissipate the heat generated.

While designing the application board, special care must be taken by placing the LM960 module on a large ground area of the application board for effective heat dissipation.



Information – The LM960 must be connected to the ground and metal chassis of the host board for best RF performance and thermal dissipation.

- The two holes at the top of the module and the main ground of the host board must be fastened together.
- The module shield and the host device main board or metal chassis should be connected by means of conductive materials.

---

#### 4.3.3. Power Supply PCB layout Guidelines

As described in the electrical design guidelines, the power supply must have a low ESR capacitor on the output to cut current peaks and a protection diode on the input to protect the supply from spikes and polarity inversion. Placement of these components is crucial for the correct operation of the circuitry: a misplaced component can be useless or can even decrease the power supply performances.

- The bypass low ESR capacitor must be placed close to the LM960 power input pins or - if the power supply is of a switching type - it can be placed close to the inductor to reduce ripple, as long as the PCB trace from the capacitor to LM960 is wide enough to ensure a drop-less connection even during the 2A current peaks.
- The protection diode must be placed close to the input connector where the power source is drained.
- The PCB traces from the input connector to the power regulator IC must be wide enough to ensure that no voltage drops occur during the 2A current peaks.
- The PCB traces to LM960 and the bypass capacitor must be wide enough to ensure that no significant voltage drops occur when the 2A current peaks are absorbed. This is needed for the same above-mentioned reasons. These traces should be kept as short as possible.

- The PCB traces connecting the switching output to the inductor and the switching diode must be kept as short as possible by placing the inductor and the diode very close to the power switching IC (only for the switching power supply). This is done to reduce the radiated field (noise) at the switching frequency (usually 100-500 kHz).
- Use a good common ground plane.
- Place the power supply on the board in a way to guarantee that the high current return paths in the ground plane do not overlap any noise sensitive circuitry, such as the microphone amplifier/buffer or earphone amplifier.
- The power supply input cables must be kept separate from noise sensitive lines, such as microphone/earphone cables.

#### 4.4. RTC

The RTC within the LM960 module does not have a dedicated RTC supply pin. The RTC block is supplied by the VBATT supply.

If VBATT power is removed, RTC is not maintained so if maintaining an internal RTC is needed, VBATT must be supplied continuously.

#### 4.5. Reference Voltage

1.8V regulated power supply output is provided as the reference voltage to a host board. This output is active when the module is ON and goes OFF when the module is shut down.

This table lists the VREG\_L6\_1P8 signal of LM960.

##### LM960 Reference Voltage

PIN	Signal	I/O	Function	Type	Comment
28	VREG_L6_1P8	O	Reference Voltage	power	1.8V

#### 4.6. Internal LDO for GNSS bias

The LDO for GNSS bias is applied inside the LM960 model.

The voltage supply come from LM960's LDO to GNSS active antenna.

This table lists the LDO for GNSS bias of LM960.

##### LM960 Reference Voltage when VBATT is 3.3

Symbol	Parameter	Min	Typ	Max	Unit
$V_{\text{GNSS DC bias}}$	Voltage of Internal LDO for GNSS bias	2.9	3.1	3.15	[V]
$I_{\text{GNSS DC bias}}$	Current of Internal LDO for GNSS bias	-	-	100	[mA]

## 5. ELECTRICAL SPECIFICATIONS

### 5.1. Absolute Maximum Ratings – Not Operational



**Caution – A deviation from the value ranges listed below may harm the LM960 module.**

#### Absolute Maximum Ratings – Not Operational

Symbol	Parameter	Min	Max	Unit
VBATT	Battery supply voltage on pin VBATT	-0.5	+4.2	[V]

### 5.2. Recommended Operating Conditions

#### Recommended Operating Conditions

Symbol	Parameter	Min	Typ	Max	Unit
T <sub>amb</sub>	Ambient temperature	-40	+25	+85	[°C]
VBATT	Battery supply voltage on pin VBATT	3.1	3.3	3.6	[V]
I <sub>VBATT +</sub> I <sub>VBATT_PA</sub>	Peak current to be used to dimension decoupling capacitors on pin VBATT	-	80	2500	[mA]



## 6. DIGITAL SECTION

### 6.1. Logic Levels

Unless otherwise specified, all the interface circuits of the LM960 are 1.8V CMOS logic.

Only USIM interfaces are capable of dual voltage I/O.

The following tables show the logic level specifications used in the LM960 interface circuits. The data specified in the tables below is valid throughout all drive strengths and the entire temperature ranges.



**Caution – Do not connect LM960’s digital logic signal directly to OEM’s digital logic signal with a level higher than 2.3V for 1.8V CMOS signals.**

#### 6.1.1. 1.8V Pins – Absolute Maximum Ratings

##### Absolute Maximum Ratings – Not Functional

Parameter	Min	Max
Input level on any digital pin when on	--	+2.16V
Input voltage on analog pins when on	--	+2.16 V

#### 6.1.2. 1.8V Standard GPIOs

##### Operating Range – Interface Levels (1.8V CMOS)

Parameter	Min	Max	Unit	Comment
VIH Input high level	1.17V	2.1V	[V]	
VIL Input low level	-0.3V	0.63V	[V]	
VOH Output high level	1.35V	1.8V	[V]	
VOL Output low level	0V	0.45V	[V]	
IIL Low-level input leakage current	-1	--	[uA]	No pull-up
IIH High-level input leakage current	--	1	[uA]	No pull-down

Parameter		Min	Max	Unit	Comment
IILPU	Low-level input leakage current	-97.5	-27.5	[uA]	With pull-up
IHPD	High-level input leakage current	27.5	97.5	[uA]	With pull-down
CI/o	I/O capacitance	--	5	[pF]	

### 6.1.3. 1.8V SIM Card Pins

#### Operating Range – SIM Pins Working at 1.8V

Parameter		Min	Max	Unit	Comment
VIH	Input high level	1.26V	2.1V	[V]	
VIL	Input low level	-0.3V	0.36V	[V]	
VOH	Output high level	1.44V	1.8V	[V]	
VOL	Output low level	0V	0.4V	[V]	
IIL	Low-level input leakage current	--	1000	[uA]	No pull-up
IHH	High-level input leakage current	-20	20	[uA]	No pull-down

### 6.1.4. 2.85V Pins – Absolute Maximum Ratings

#### Absolute Maximum Ratings – Not Functional

Parameter	Min	Max
Input level on any digital pin when on	--	+3.42V
Input voltage on analog pins when on	--	+3.42 V

### 6.1.5. SIM Card Pins @2.85V

#### Operating Range – For SIM Pins Operating at 2.85V

Parameter		Min	Max	Unit	Comment
VIH	Input high level	1.995V	3.15V	[V]	
VIL	Input low level	-0.3V	0.57V	[V]	
VOH	Output high level	2.28V	2.85V	[V]	

Parameter		Min	Max	Unit	Comment
VOL	Output low level	0V	0.4V	[V]	
IIL	Low-level input leakage current	--	1000	[uA]	No pull-up
IILH	High-level input leakage current	-20	20	[uA]	No pull-down

## 6.2. Power On

The LM960 is automatically turning on when the VBATT is supplied.



Information – To turn on the LM960 module, the SYSTEM\_RESET\_N pin must not be asserted low.

### 6.2.1. Initialization and Activation State

After turning on the LM960, the module is not instantly activated because the SW initialization process takes some time to complete.

For this reason, it is recommended not to communicate with the LM960 during the Initialization phase.

As soon as the AT command interface is accessible via USB port, Boot OK line transitions to high but this does not imply that the device is fully operational yet.

One of GPIO pins can be configured as Shutdown indicator by means of AT#SHDNIND command: in that case, that GPIO will also work as Boot OK line when the module is booting.

Please refer to AT Commands Reference Guide for additional details.

In general, as shown in below figure, the LM960 becomes fully operational (in the Activation state) at least 35 seconds after the VBATT is supplied.

## LM960 Initialization and Activation

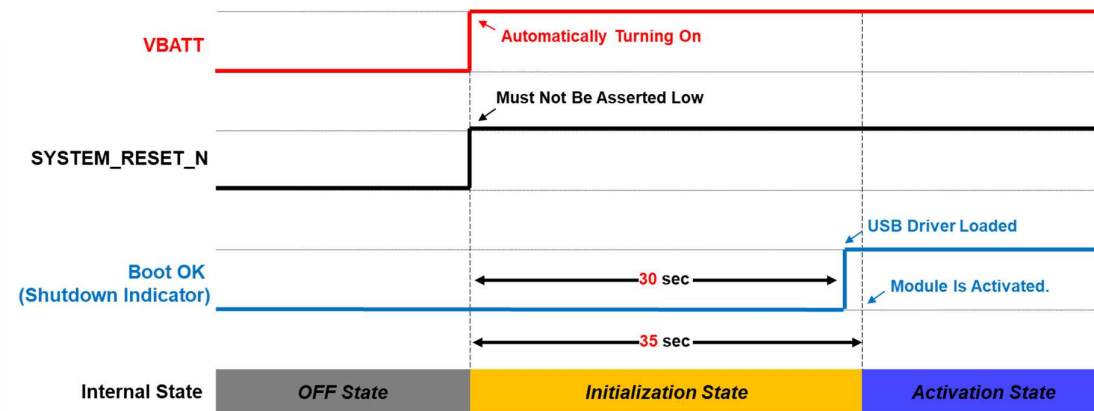

Information – To verify if the LM960 has powered up properly, please check through one of two conditions below:

- (1) LM960 and the host should be connected via USB. When USB driver is completely loaded, the module has powered on without problems and is ready to accept AT commands.
- (2) Monitoring Boot OK (Shutdown Indicator). To use Boot OK (Shutdown Indicator), Boot OK(Shutdown Indicator) function must be enabled through AT#SHDNIND. (Refer to the AT User Guide document)

Information – Active low signals are labeled with a name that ends with “\_N”



Information – To avoid a back-powering effect, it is recommended to avoid having any HIGH logic level signal applied to the digital pins of the module when it is powered OFF or during an ON/OFF transition.

### 6.3. Power Off

Power off the device can be done in three different ways:

- Graceful Shutdown by USB AT command AT#SHDN
- Fast Shutdown by GPIO triggered or USB AT command AT#FASTSHDN

- Unconditional Shutdown using the SYSTEM\_RESET\_N

### 6.3.1. Graceful Shutdown

To shutdown the LM960 module safely, host can use the graceful shutdown function.

The graceful shutdown can be triggered by:

- AT command via USB

#### 6.3.1.1. Graceful Shutdown by AT command

To gracefully shutdown the LM960 module, AT#SHDN command must be sent via a USB communication.

Once the shutdown command is sent, the LM960 module enters finalization state, terminates active processes and prepares to turn off safely.

As shown in the diagram below, Shutdown indicator will indicate when the module is ready to be turned off.

Please refer to the AT User Guide for more detail about AT#SHDN and AT#SHDNIND.

#### Graceful Shutdown by AT Command

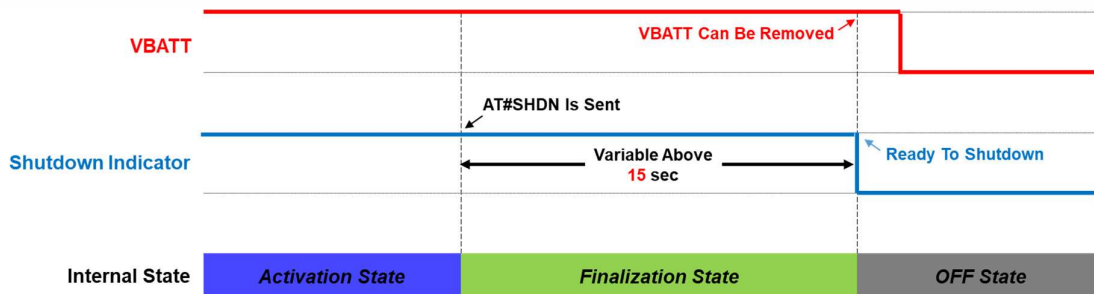

The DTE should monitor the status of Shutdown Indicator to proceed graceful power-off.



Information – VBATT must not be removed before Shutdown Indicator goes LOW.



Warning – Not following the recommended shut-down procedures might damage the device and consequently void the warranty.

### 6.3.2. Fast Shutdown

For a quicker shutdown of the LM960 module, the host can use the fast shutdown function. Fast shutdown can be triggered by:

- AT command via USB
- GPIO

#### 6.3.2.1. Fast Shutdown by AT command

Once AT#FASTSHDN command is sent through the USB port, the LM960 enters finalization state, terminates active processes and preparing to safely turn off.

As shown in the diagram below, when the module is ready to be turned off, it will be indicated via Shutdown Indicator.

One of GPIO lines can be configured as Shutdown Indicators function by means of AT commands: please refer to the AT User Guide for more details about AT#FASTSHDN and AT#SHDNIND.

#### Fast Shutdown by AT command

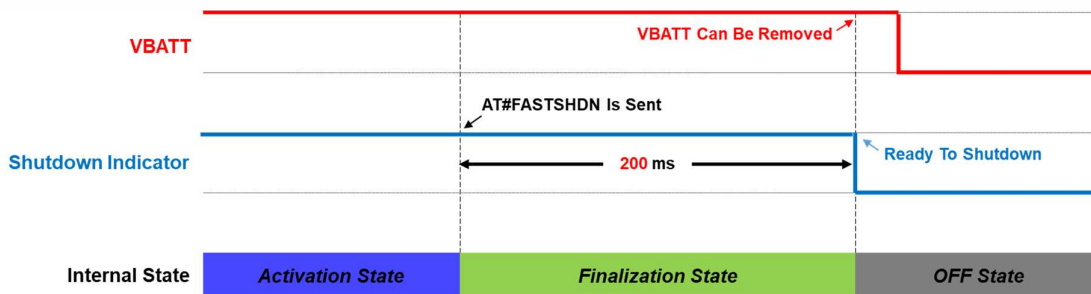

The DTE should monitor the status of Shutdown Indicator to proceed fast power-off.



Information – VBATT must not be removed before Shutdown Indicator goes LOW.



Warning – Not following the recommended shut-down procedures might damage the device and consequently void the warranty.

### 6.3.2.2. Fast Shutdown by GPIO

If properly configured, one of GPIO lines can be used as Fast Shutdown Trigger.

Once the Fast Shutdown Trigger senses a HIGH to LOW transition, fast shutdown is initiated.

Then the LM960 module enters finalization state, terminates active processes and prepares to turn off safely. As shown in below figure, when the module is ready to be turned off, it will be indicated via Shutdown Indicator.

Please refer to the AT User Guide for more detail about enable Shutdown Indicator and Fast Shutdown Trigger.

#### Fast Shutdown by GPIO

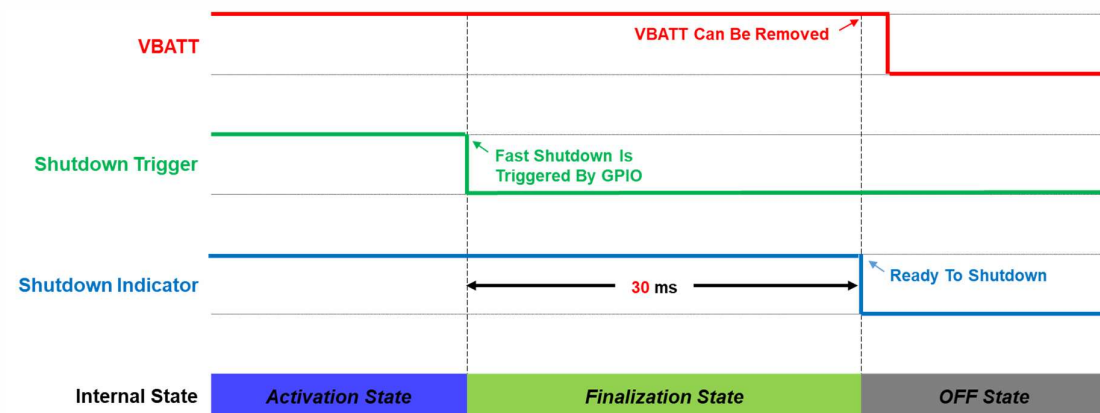

The DTE should monitor the status of Shutdown Indicator to proceed fast power-off.



Information – VBATT must not be removed before Shutdown Indicator goes LOW.

---



Warning – Not following the recommended shut-down procedures might damage the device and consequently void the warranty.

---

### 6.3.3. Unconditional Shutdown

To turn off the LM960, SYSTEM\_RESET\_N pad must be asserted low for more than 1 seconds and then it should be kept low.

When the SYSTEM\_RESET\_N is asserted low more than 1 second, the LM960 enters finalization state and after the end of the shutdown process Shutdown Indicator will go to low.

Usually, it takes the LM960 less than 100 milliseconds from asserting SYSTEM\_RESET\_N until reaching a complete shutdown. The DTE should monitor the status of Shutdown Indicator to observe the actual power-off.

---



Information – To completely shut down the LM960 module, the SYSTEM\_RESET\_N pin must be asserted and kept low.

Otherwise, the LM960 will turn on again after shut down.

---



Information – To avoid a back-powering effect, it is recommended to avoid having any HIGH logic level signal applied to the digital pins of the module when it is powered OFF or during an ON/OFF transition.

---





Warning – Not following the recommended shut-down procedures might damage the device and consequently void the warranty.

### Shutdown by SYSTEM\_RESET\_N Pad

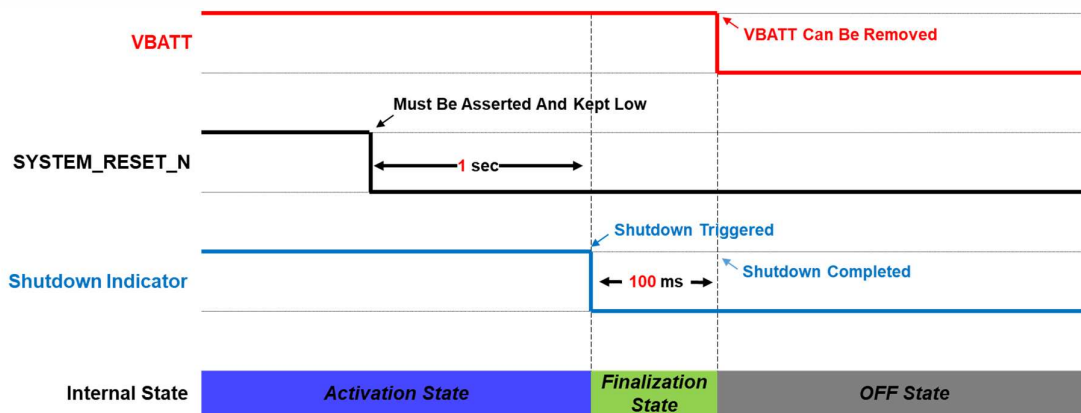

Below figure shows a simple circuit for this action.

### Circuit for Shutdown by SYSTEM\_RESET\_N

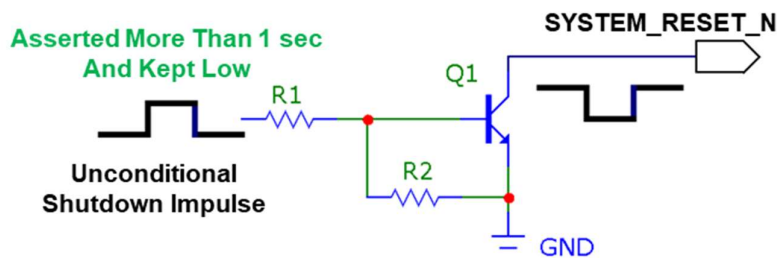

## 6.4. Reset

Device reset can be achieved as follows:

- Graceful Reset by USB AT command AT#REBOOT
- Unconditional Reset using the SYSTEM\_RESET\_N

6.4.1. Graceful Reset

To gracefully restart the LM960 module, AT#REBOOT AT command must be sent through USB port.

**Graceful Reset by AT#REBOOT**

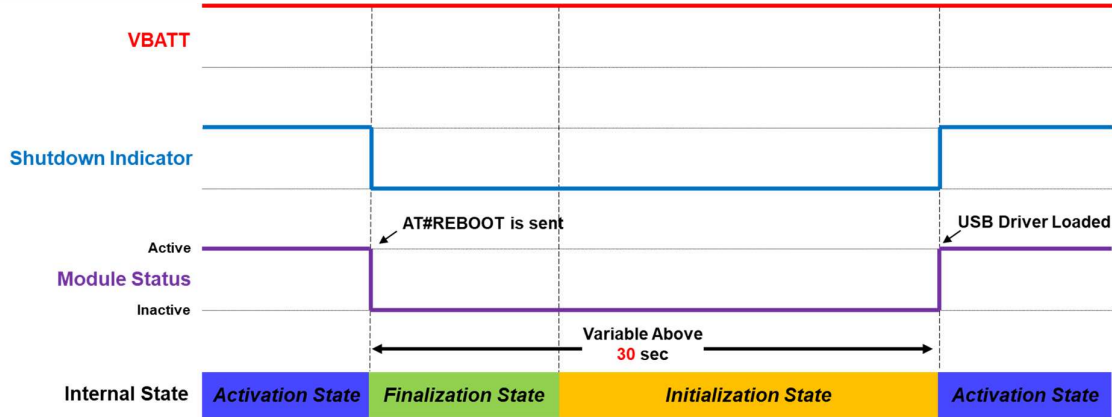

6.4.2. Unconditional Hardware Reset

To unconditionally restart the LM960 module, the SYSTEM\_RESET\_N pin must be asserted low more than 1 seconds and then released.

**Unconditional Hardware Reset by SYSTEM\_RESET\_N Pad**

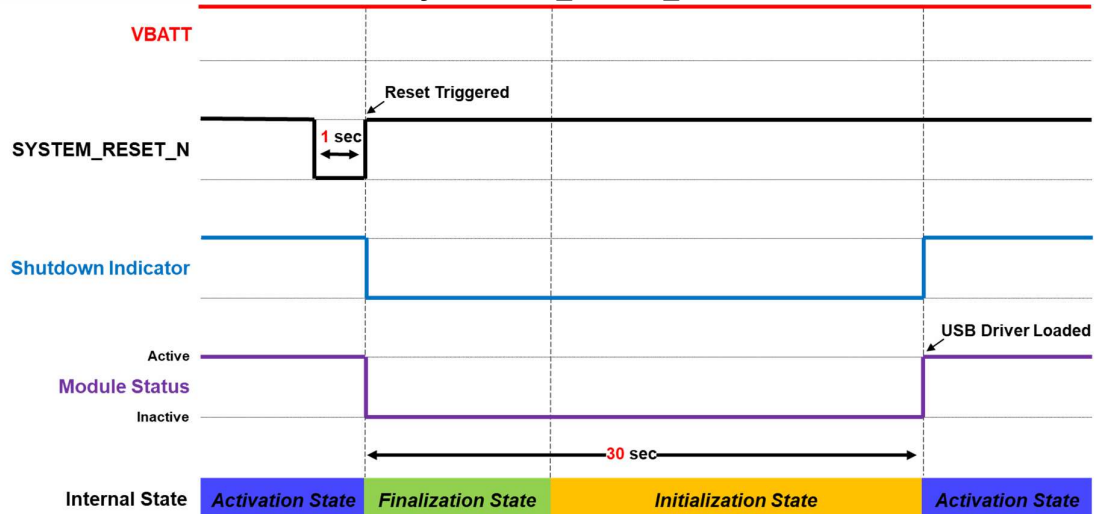

Information – Unconditional Hardware Reset must be used only as an emergency exit procedure, and not as a normal power-off operation.



Information – Do not use any pull-up resistor on the RESET\_N line or any totem pole digital output. Using a pull-up resistor may cause latch-up problems on the LM960 power regulator and improper functioning of the module.

The RESET\_N line must be connected only in an open-collector configuration.

### 6.5. Dying Gasp

If any major issue occurs within the Host System, the host itself can use the dying gasp function by notifying the LM960 module.

One of GPIOs can be configured as Dying Gasp Trigger by means of AT commands.

Once the Dying Gasp Trigger receives a HIGH to LOW transition, the dying gasp procedure is triggered: the LM960 will send the specified SMS and then initiate fast shutdown.

#### Dying Gasp by GPIO, Max Power Non-CA , Current :500mA, 3.3V

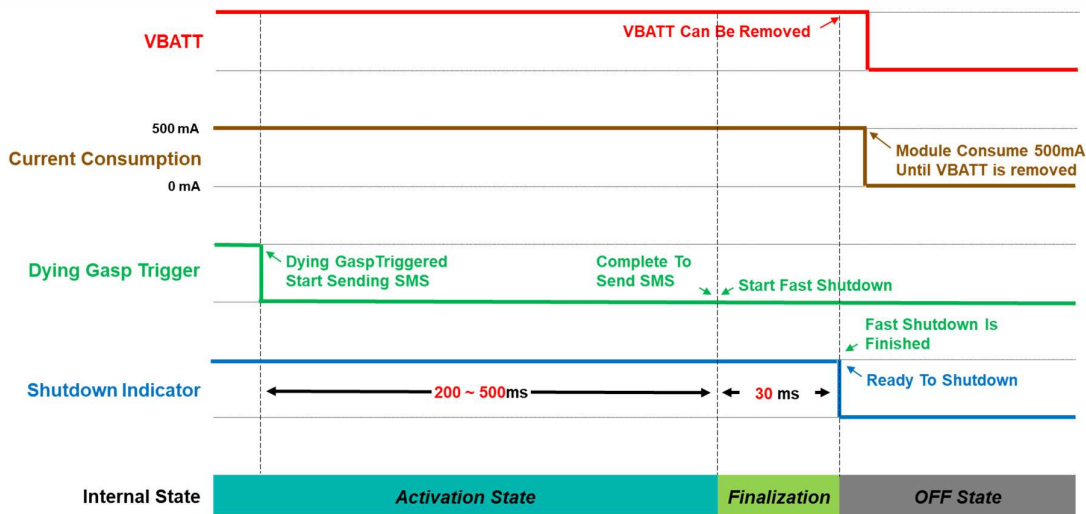

#### Dying Gasp by GPIO, Max Power with 3DL CA 4x4 MIMO , Current :1300mA, 3.3V

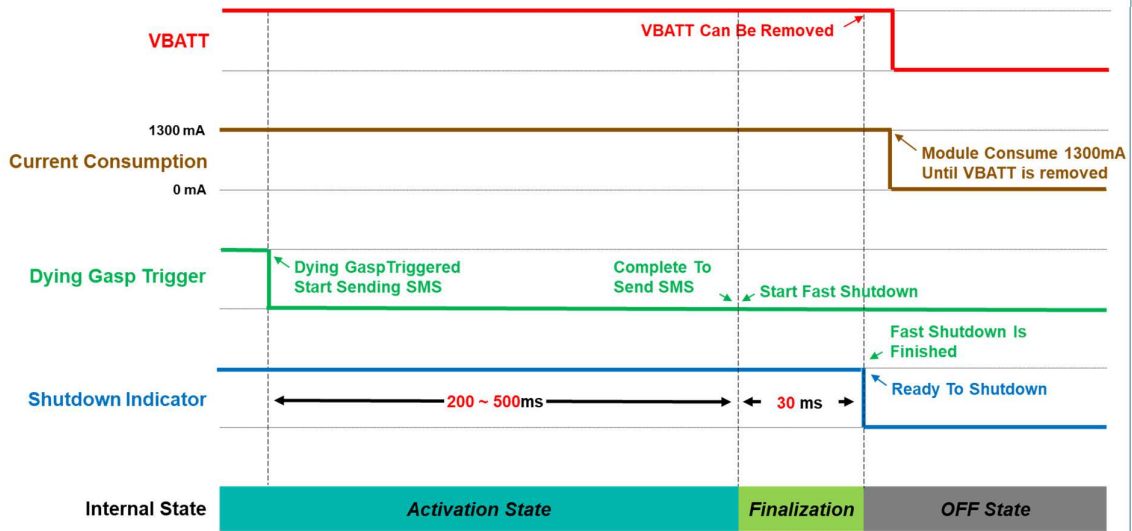

Usually dying gasp feature is completed less than 1 second after triggered.

This may take longer depending on network conditions.

## 6.6. Communication ports

Below table summarizes hardware interfaces available of the LM960 module.

### LM960 Hardware Interfaces

Interface	LM960
<b>USB</b>	Super-speed USB3.0 with high-speed USB2.0
<b>PCIe</b>	Peripheral Component Interconnect Express
<b>USIM</b>	x2, dual voltage each (1.8V/2.85V)
<b>Control Signals</b>	W_DISABLE_N, WAKE_N, WAN_LED_N
<b>GPIO</b>	X8, GPIO
<b>I2C</b>	I2C (optional)
<b>Antenna ports</b>	4 for Cellular, 1 for GNSS

#### 6.6.1. USB Interface

The LM960 module includes super-speed USB3.0 with high-speed USB2.0 backward compatibility. It is compliant with Universal Serial Bus Specification, Revision 3.0 and can be used for control and data transfers as well as for diagnostic monitoring and firmware update.

The USB port is typically the main interface between the LM960 module and OEM hardware.

USB 3.0 needs AC coupling series capacitors on the TX lines in both directions. In order to interface USB3.0 with the application board controlling the modem, 0.1uF capacitors should be installed on USB\_SS\_RX\_P/M lines of the LM960. Series capacitors are already placed on USB\_SS\_TX\_P/M lines inside LM960 module.

The USB interface suggested connection is the following:

**Connection for USB Interface**

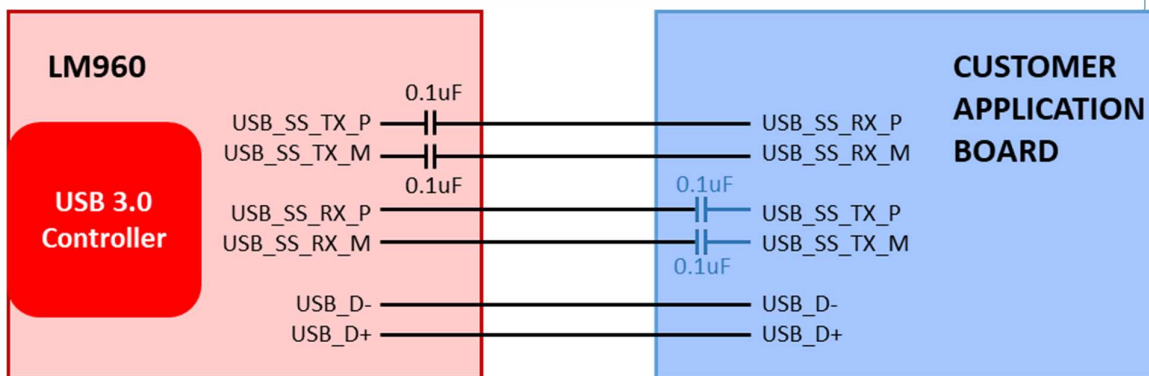

\*CUSTOMER : Need series capacitor (0.1uF) at USB\_SS\_RX\_P/M Lines



Information – The USB signal traces must be carefully routed: minimize trace lengths, number of vias, and capacitive loading. The impedance value should be as close as possible to 90 Ohms differential.



Warning – At power-up, LM960 success to enumerate SS\_USB interface. But if a hot-plug is attempted in case of SS\_USB, then LM960 may fail to enumerate SS\_USB.

The table below lists the USB interface signals.

**USB Interface Signals**

PIN	Signal	I/O	Function	Type	Comment
38	USB_D+	I/O	USB 2.0 Data Plus	Analog	
36	USB_D-	I/O	USB 2.0 Data Minus	Analog	
33	USB_SS_RX_P	I	USB 3.0 super-speed receive – plus	Analog	
31	USB_SS_RX_M	I	USB 3.0 super-speed receive – minus	Analog	
25	USB_SS_TX_P	O	USB 3.0 super-speed transmit – plus	Analog	
23	USB_SS_TX_M	O	USB 3.0 super-speed transmit – minus	Analog	



Information – Even if USB communication is not used, it is still highly recommended to place an optional USB connector on the application board.

At least test points of the USB signals are required since the USB physical communication is needed in the case of SW update.



Information – Consider placing a low-capacitance ESD protection component to protect LM960 against ESD strikes

If an ESD protection is required, it is suggested to connect it as follows:

#### ESD Protection for USB2.0

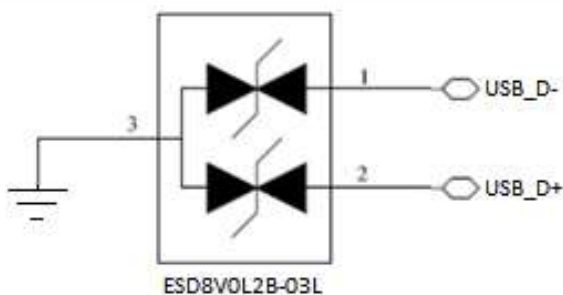

**ESD Protection for USB3.0**

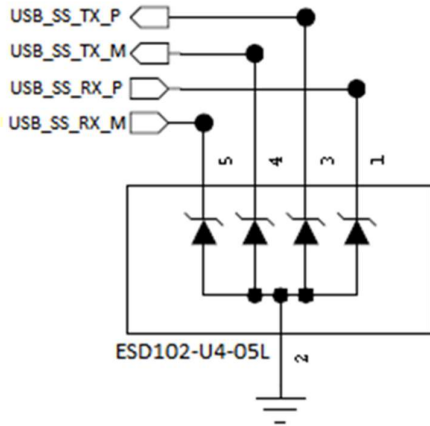

6.6.2. SIM Interface

The LM960 supports two external SIM interfaces (1.8V or 2.85V).

Below table lists the SIM interface signals.

**SIM Interface Signals**

PIN	Signal	I/O	Function	Type	Comment
<b>SIM Card Interface 1</b>					
8	SIMVCC1	O	Supply output for an external UIM1 card	1.8V / 2.85V	Power
10	SIMIO1	I/O	Data connection with an external UIM1 card	1.8V / 2.85V	
12	SIMCLK1	O	Clock output to an external UIM1 card	1.8V / 2.85V	
14	SIMRST1	O	Reset output to an external UIM1 card	1.8V / 2.85V	
<b>SIM Card Interface 2</b>					
16	SIMVCC2	O	Supply output for an external UIM2 card	1.8 / 2.85V	Power
19	SIMIO2	I/O	Data connection with an external UIM2 card	1.8 / 2.85V	
17	SIMCLK2	O	Clock output to an external UIM2 card	1.8 / 2.85V	

<b>6</b>	SIMRST2	O	Reset output to an external UIM2 card	1.8 / 2.85V	
<b>Digital I/O (GPIOs)</b>					
<b>3</b>	GPIO_01	I	UIM1 Card Present Detect	1.8V	GPIO_01 can be used as SIMIN1
<b>5</b>	GPIO_02	I	UIM2 Card Present Detect	1.8V	GPIO_02 can be used as SIMIN2

6.6.2.1. SIM Schematic Example

The following Figures illustrate in particular how the application interface should be designed.

**SIM Schematics**

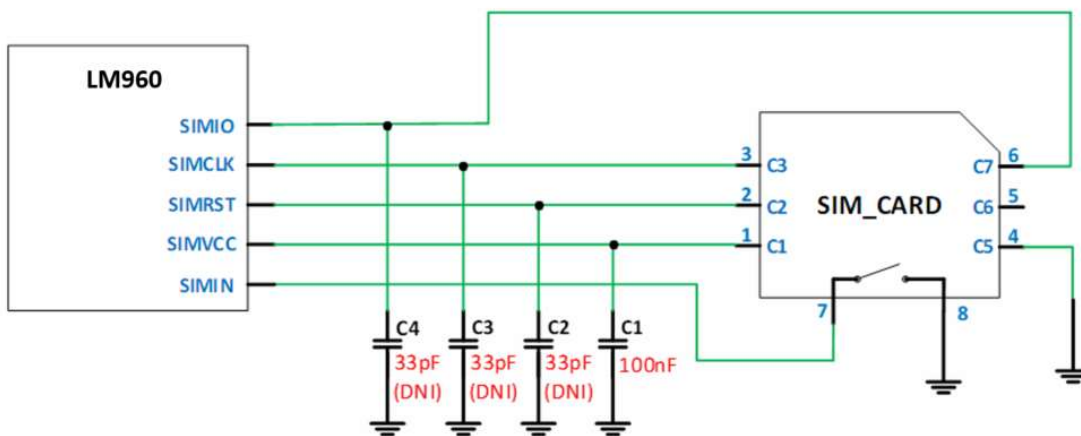

Information – LM960 contains an internal pull-up resistor on SIMIO. It is not necessary to install external pull – up resistor.

6.6.3. Control Signals

The LM960 supports the following control signals:

- W\_DISABLE\_N
- PCIE\_WAKE\_N
- WAN\_LED\_N



Below table lists the control signals of LM960.

### Module Control Signal

PIN	Signal	I/O	Function	Type	Comment
20	W_DISABLE_N	I	RF disable (airplane mode)	Open-drain	Internal VBATT Pull-up
1	PCIE_WAKE_N	I/O	PCIe wake-up	1.8V	
42	WAN_LED_N	O	LED control	Open-drain	

#### 6.6.3.1. W\_DISABLE\_N

The W\_DISABLE\_N signal is provided to trigger the LM960 to switch to airplane mode:

- Enter into the airplane mode: Low
- Normal operating mode: High or Leave the W\_DISABLE\_N not connected

LM960 contains an internal VBATT(Nominal 3.3V) pull-up resistor on W\_DISABLE\_N.

#### 6.6.3.2. WAN\_LED\_N

The WAN\_LED\_N signal drives the LED output.

The recommended WAN\_LED\_N connection is the following:

#### Recommended WAN\_LED\_N connection

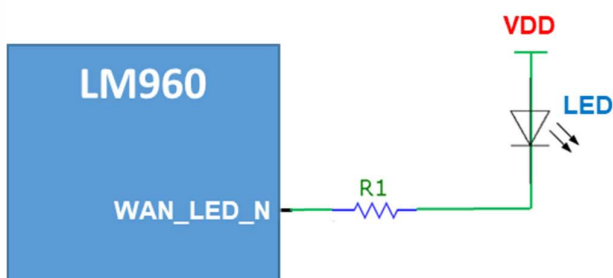

R1 and VDD determine the brightness of LED and forward current.

When VDD is 3.3V and LED's forward voltage is 2.0V, it is recommended to choose R1 value between 66 and 250 Ohm.

However, resistor value must be calculated considering the specification of the LED to use.



Information – If enable the LED function and connect the LED to the WAN\_LED\_N pin, current consumption may be increased.

#### 6.6.4. General Purpose I/O

The general-purpose I/O pins can be configured to act in three different ways:

- Input
- Output
- Dedicated Function

Input pins can only be read and report digital values (high or low) present on the pin at the read time.

Output pins can only be set or the pin level can be queried.

Below table lists the GPIO signals of LM960.

#### GPIOs

Pin no.	Signal	I/O	Function	Type	Drive Strength
3	GPIO_01	I/O	Configurable GPIO	Pull-Down 1.8V	2-16 mA
5	GPIO_02	I/O	Configurable GPIO	Pull-Down 1.8V	2-16 mA
44	GPIO_03	I/O	Configurable GPIO	Pull-Down 1.8V	2-16 mA
46	GPIO_04	I/O	Configurable GPIO	Pull-Down 1.8V	2-16 mA
45	GPIO_05	I/O	Configurable GPIO	Pull-Down 1.8V	2-16 mA
47	GPIO_06	I/O	Configurable GPIO	Pull-Down 1.8V	2-16 mA
49	GPIO_07	I/O	Configurable GPIO	Pull-Down 1.8V	2-16 mA
51	GPIO_08	I/O	Configurable GPIO	Pull-Down 1.8V	2-16 mA

6.6.4.1. Using a GPIO Pin as Input

GPIO pins, when used as inputs, can be tied to a digital output of another device and report its status, provided the device interface levels are compatible with the GPIO 1.8V CMOS levels.

If a digital output of a device is tied to GPIO input, the pin has interface levels different than 1.8V CMOS. It can be buffered with an open collector transistor with a 47 kΩ pull-up resistor to 1.8V.

6.6.4.2. Using a GPIO Pin as Output

GPIO pins, when used as outputs, can drive 1.8V CMOS digital devices or compatible hardware. When set as outputs, the pins have a push-pull output, and therefore the pull-up resistor can be omitted.

**GPIO Output Pin Equivalent Circuit**

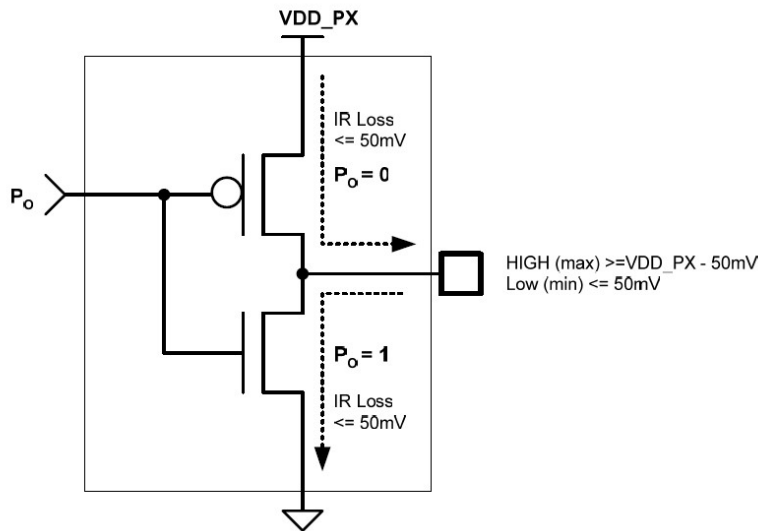

6.6.4.3. Dedicated I/O

In order to use SIMIN functions, host must use GPIO\_01/GPIO\_02.

**Dedicated I/O**

Pin no.	Signal	IO/Level	Dedicated Function
3	GPIO_01	Input/1.8V	Can be used as SIMIN1 function
5	GPIO_02	Input/1.8V	Can be used as SIMIN2 function

Below functions are not dedicated to specific GPIO.

One of the dedicated GPIOs (GPIO\_03 to GPIO\_08) can be configured by means of AT commands for one of the following functions:

- Boot OK
- Shutdown Indicator
- Shutdown Trigger
- Dying Gasp Trigger

### Not Dedicated I/O

Pin no.	Signal	I/O/Level	Dedicated Function
44	GPIO_03	I/O, 1.8V	Can be used as specific functions.
46	GPIO_04	I/O, 1.8V	Can be used as specific functions.
45	GPIO_05	I/O, 1.8V	Can be used as specific functions.
47	GPIO_06	I/O, 1.8V	Can be used as specific functions.
49	GPIO_07	I/O, 1.8V	Can be used as specific functions.
51	GPIO_08	I/O, 1.8V	Can be used as specific functions.

#### 6.6.5. I2C – Inter-integrated circuit

The LM960 supports an I2C interface on the following pins:

Below table lists the I2C signals of LM960.

### Module I2C Signal

PIN	Signal	I/O	Function	Type	Comment
30	I2C_SCL	O	I2C Clock	CMOS 1.8V	
32	I2C_SDA	I/O	I2C Data	CMOS 1.8V	

The I2C interface is used for controlling peripherals outside the module (such as codec, etc.).



Information – I2C is supported only on from Modem side as SW emulation of I2C on GPIO lines.

Please contact Telit Customer support for further information.

---



Information – If the I2C interface is not used, the signals can be left floating.

---

## 6.7. Using the Temperature Monitor Function

The Temperature Monitor allows to monitor the module's internal temperature and, if properly set (see the #TEMPSENS command in LM960 AT Commands Reference Guide), raises a GPIO to High Logic level when the maximum temperature is reached.

## 7. RF SECTION

### 7.1. Antenna requirements

The antenna connection is one of the most important aspect in the full product design as it strongly affects the product overall performance. Hence, please read carefully and follow the requirements and the guidelines for a proper design.

The LM960/LM960A18 is provided with five RF connectors.  
The available connectors are:

- Primary RF antenna #0: Tx and Rx path for low bands and middle bands / 4x4 MIMO path of band41.
- Primary RF antenna #1: Tx and Rx path for high bands, ultra high bands and band32 / 4x4 MIMO path of band2(band25) and band4(band66)
- Secondary RF antenna #0: Rx Diversity path for low bands, middle bands / 4x4 MIMO path of band41 / GNSS path
- Secondary RF antenna #1: Rx Diversity path for high bands, ultra high bands and band32 / 4x4 MIMO path of band2(band25) and band4(band66)
- GNSS antenna: Dedicated GNSS path

The LM960A9-P is provided with four RF connectors.  
The available connectors are:

- Primary RF antenna #1: Tx and Rx path for ultra high bands
- Secondary RF antenna #0: GNSS path
- Secondary RF antenna #1: Rx Diversity path for ultra high bands
- GNSS antenna: Dedicated GNSS path

### 7.2. Primary Antenna Requirements

The antenna for the LM960 device must meet the following requirements:

#### WCDMA / LTE Antenna Requirements

Frequency range	Depending by frequency band(s) provided by the network operator, the customer shall use the most suitable antenna for that/those band(s)  The bands supported by the LM960 is provided in <a href="#">Section 2.2, Product Variants and Frequency Bands</a> .
Impedance	50 Ohm
Input power	> 24 dBm average power in WCDMA & LTE

VSWR absolute max	$\leq 10:1$
VSWR recommended	$\leq 2:1$

### 7.3. Secondary Antenna Requirements

This product includes an input for a second Rx antenna to improve radio sensitivity. The function is called Antenna Diversity.

#### Antenna Diversity Requirements

Frequency range	Depending by frequency band(s) provided by the network operator, the customer shall use the most suitable antenna for that/those band(s)  The bands supported by the LM960 is provided in Section <a href="#">2.2, Product Variants and Frequency Bands</a> .
Impedance	50 $\Omega$
VSWR recommended	$\leq 2:1$

The second Rx antenna should not be located in the close vicinity of the main antenna. In order to improve Diversity Gain, Isolation and reduce mutual interaction, the two antennas should be located at the maximum reciprocal distance possible, taking into consideration the available space. For the same reason, the Rx antenna should also be cross-polarized with respect to the main antenna.

Isolation between main antenna and Rx antenna must be at least 10 dB in all uplink frequency bands.

Envelope Correlation Coefficient (ECC) value should be as close as possible to zero, for best diversity performance. ECC values below 0.5 on all frequency bands are recommended.

## 7.4. GNSS Receiver

The LM960 integrates a GNSS receiver that could be used in Standalone mode and in A-GPS (assisted GPS), according to the different configurations.

LM960 supports an active antenna.

Frequency range	<ul style="list-style-type: none"> <li>• Wide-band GNSS: 1559–1606 MHz recommended</li> <li>• GPS: 2.046 MHz BW NB GPS (centered on 1575.42 MHz)</li> <li>• Glonass (GLO): ~ 8.3 MHz BW (1597–1606 MHz)</li> <li>• BeiDou (BDS): 4.092 MHz BW (1559.05 – 1563.14 MHz)</li> <li>• Galileo (GAL): 4.092 MHz BW (centered on 1575.42 MHz)</li> </ul>
Gain	1.5 dBi < Gain < 3 dBi
Impedance	50 Ohm
Amplification	18 dB < Gain < 21 dB
Supply Voltage	3.1 V
Current consumption	20 mA Typical

### 7.4.1. GNSS RF Front End Design

The LM960 contains an integrated LNA and pre-select SAW filter. This allows the module to work well with a passive GNSS antenna. If the antenna cannot be located near the LM960, then an active antenna (that is, an antenna with a low noise amplifier built in) can be used with an external dedicated power supply circuit.

GNSS receive path uses either the dedicated GNSS connector or the shared Secondary #0 antenna connector.



NOTE – Please refer to the LM960 AT Commands Reference Guide, 80568ST10869A for detailed information about GNSS operating modes and GNSS Antenna selection.



## 7.5. Antenna connection

### 7.5.1. Support bands on antenna ports

The LM960/LM960A18 has an assigned antenna port depending on the frequency band.

The supported bands on each antenna port are:

- Primary RF antenna #0: B1, B2(B25), B3, B4(B66), B5(B26,B18,B19), B8, B12(B17), B13, B14, B20, B28, B29, B39, B71, B41 for 4 x 4 MIMO
- Primary RF antenna #1: B7, B30, B32, B38, B40, B41, B42, B43, B46, B48, B2(B25) for 4 x 4 MIMO, B4(B66) for 4 x 4 MIMO
- Secondary RF antenna #0: B1, B2(B25), B3, B4(B66), B5(B26,B18,B19), B8, B12(B17), B13, B14, B20, B28, B29, B39, B71, B41 for 4 x 4 MIMO / GNSS
- Secondary RF antenna #1: B7, B30, B32, B38, B40, B41, B42, B43, B46, B48, B25(B2) for 4 x 4 MIMO, B66(B4) for 4 x 4 MIMO
- GNSS antenna: Dedicated GNSS

Please refer to the picture below for their position:.

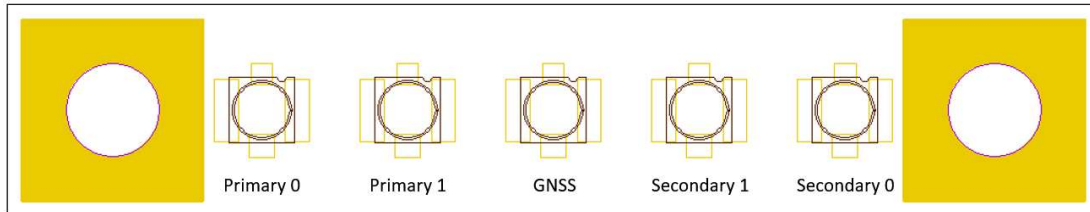

The LM960A9-P has an assigned antenna port depending on the frequency band.

The supported bands on each antenna port are:

- Primary RF antenna #1: B42, B43, B48
- Secondary RF antenna #0: GNSS
- Secondary RF antenna #1: B42, B43, B48
- GNSS antenna: Dedicated GNSS

Please refer to the picture below for their position:.

The LM960A9-P is not mounted with a primary 0 antenna connector.

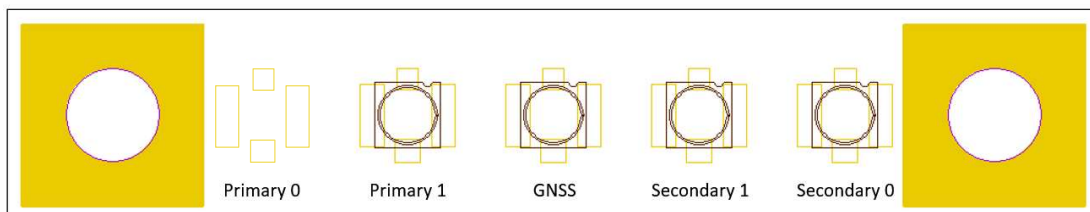

### 7.5.2. Antenna Connector

The LM960 is equipped with a set of 50  $\Omega$  RF MHF4 connectors from I-PEX 20449-001.

For more information about mating connectors, please <https://www.i-pex.com>

### 7.5.3. Antenna Cable

Connecting cables between the module and the antenna must have 50  $\Omega$  impedance. If the impedance of the module is mismatched, RF performance is reduced significantly. If the host device is not designed to use the module's GNSS antenna, the interface must be terminated with a 50 $\Omega$  load.

#### Minimize Antenna Cable Requirements

Impedance	50 Ohm
Max cable loss	Less than 0.5 dB
Avoid coupling with other signals.	

### 7.5.4. Antenna Installation Guidelines

- Install the antenna in a location with access to the network radio signal.
- The antenna must be installed such that it provides a separation distance of at least 20 cm from all persons and must not be co-located or operating in conjunction with any other antenna or transmitter.
- The antenna must not be installed inside metal cases.
- The antenna must be installed according to the antenna manufacturer's instructions.

Furthermore, if the device is developed for the US and/or Canada market, it must comply with the FCC and/or IC approval requirements.

---

### Information



This device is to be used only for mobile and fixed application. The antenna(s) used for this transmitter must be installed to provide a separation distance of at least 20 cm from all persons and must not be co-located or operating in conjunction with any other antenna or transmitter. End-Users must be provided with transmitter operation conditions for satisfying RF exposure compliance. OEM integrators must ensure that the end user has no manual instructions to remove or install the LM960 module. Antennas used for this OEM module must not exceed gain of below table for mobile and fixed operating configurations.

In the event that these conditions cannot be met (for example certain laptop configurations or co-location with another transmitter), then the FCC/IC authorization is no longer considered valid and the FCC/IC ID cannot be used on the final product. In these circumstances, the OEM integrator will be responsible for re-evaluating the end product (including the transmitter) and obtaining a separate FCC/IC authorization.

---

### Manual Information to the End User



The OEM integrator has to be aware not to provide information to the end user regarding how to install or remove this RF module in the user's manual of the end product which integrates this module. The end user manual shall include all required regulatory information/warning as show in this manual.

---

## 8. MECHANICAL DESIGN

### 8.1. General

The LM960 module was designed to be compliant with a standard lead-free SMT process. Moreover, it is compatible with the Mini PCIe card 52-pin card edge-type connector.

### 8.2. Finishing & Dimensions

The LM960 module's overall dimensions are:

- Length: 50.95 mm
- Width: 30.00 mm
- Thickness: 2.70 mm

The module complies with the standard dimensions specified in the *PCI Express Mini Card Electromechanical Specification Revision 1.1*

### 8.3. Drawing

This figure shows the mechanical dimensions of the LM960 module.

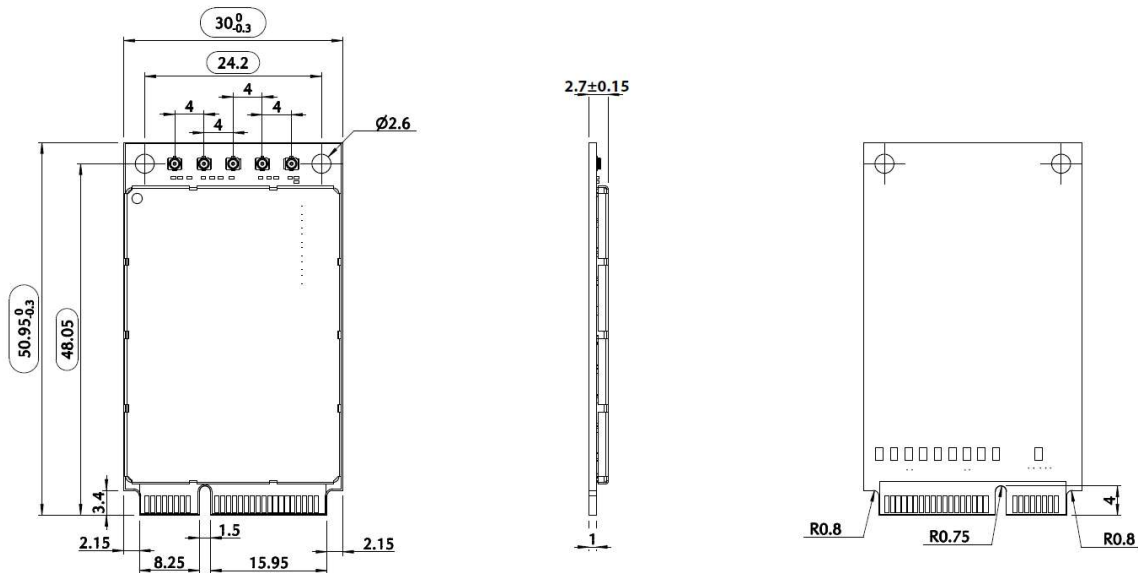

## 9. APPLICATION GUIDE

### 9.1. Debug of the LM960 Module in Production

To test and debug the LM960 module integration, we strongly recommend to add several test pins on the host PCB for the following purposes:

- Checking the connection between the LM960 itself and the application
- Testing the performance of the module by connecting it with an external computer

Depending on the customer application, these test pins include, but are not limited to the following signals:

- SYSTEM\_RESET\_N, W\_DISABLE\_N, PCIE\_WAKE\_N
- VBATT, GND
- VREG\_L6\_1P8
- USB\_D-, USB\_D+
- USB\_SS\_TX\_M, USB\_SS\_TX\_P, USB\_SS\_RX\_M, USB\_SS\_RX\_P

In addition, the following signals are also recommended (but not mandatory):

- WAN\_LED\_N
- GPIO\_01, GPIO\_02, GPIO\_03, GPIO\_04, GPIO\_05, GPIO\_06, GPIO\_07, GPIO\_08

### 9.2. Bypass Capacitor on Power Supplies

When a sudden voltage step is asserted to or a cut from the power supplies, the steep transition causes effects such as overshoot and undershoot. This abrupt voltage transition can affect the device causing it to not operate or to malfunction.

Bypass capacitors are needed to alleviate this behavior, which can appear differently depending on the various applications. Customers must pay special attention to this issue when they design their application board.

The length and width of the power lines must be considered carefully, and capacitors value must be selected accordingly.

The capacitor will also prevent power supplies ripple and the switching noise caused in TDMA systems, such as GSM.

Most important, a suitable bypass capacitor must be mounted on the following lines on the application board:

- VBATT

Recommended values are:

- 100uF for VBATT

considerate must be kept into account that the capacitance mainly depends on the application board.

Generally, additional capacitance is required when the power line is longer.

And if fast power down function is used, additional bypass capacitors should be mounted on the application board.

### 9.3. EMC Recommendations

EMC protection on the pins in the table below should be designed by application side according to the customer's requirement.

#### EMC Recommendations

Pin	Signal	I/O	Function	Type	Comment
<b>USB HS 2.0 Communication Port</b>					
38	USB_D+	I/O	USB 2.0 Data Plus	Analog	
36	USB_D-	I/O	USB 2.0 Data Minus	Analog	
<b>USB SS 3.0 Communication</b>					
33	USB	I	USB 3.0 receive – plus	Analog	
31	USB	I	USB 3.0 receive – minus	Analog	
25	USB	O	USB 3.0 transmit – plus	Analog	
23	USB	O	USB 3.0 transmit – minus	Analog	
<b>SIM Card Interface 1</b>					
14	SIMRST1	O	Reset output to an external UIM1 card	1.8 / 2.85V	
12	SIMCLK1	O	Clock output to an external UIM1 card	1.8 / 2.85V	
10	SIMIO1	I/O	Data connection with an external UIM1 card	1.8 / 2.85V	
8	SIMVCC1	O	Supply output for an external UIM1 card	1.8 / 2.85V	Power

SIM Card Interface 2						
6	SIMRST2	O	Reset output to an external UIM2 card	1.8 / 2.85V		
17	SIMCLK2	O	Clock output to an external UIM2 card	1.8 / 2.85V		
19	SIMIO2	I/O	Data connection with an external UIM2 card	1.8 / 2.85V		
16	SIMVCC2	O	Supply output for an external UIM2 card	1.8 / 2.85V		Power
Digital I/O (GPIOs)						
3	GPIO_01	I/O	General purpose I/O	1.8V		
5	GPIO_02	I/O	General purpose I/O	1.8V		
44	GPIO_03	I/O	General purpose I/O	1.8V		
46	GPIO_04	I/O	General purpose I/O	1.8V		
45	GPIO_05	I/O	General purpose I/O	1.8V		
47	GPIO_06	I/O	General purpose I/O	1.8V		
49	GPIO_07	I/O	General purpose I/O	1.8V		
51	GPIO_08	I/O	General purpose I/O	1.8V		
1	PCIE_WAKE_N	I/O	PCIe wake-up	1.8V		Active Low
42	WAN_LED_N	O	LED control	Open-drain		Active Low
Power ON/OFF Reset IN/OUT						
20	W_DISABLE_N	I	RF ON/OFF Control	Open-drain		Active Low (internal VBATT pull up)
22	PCIE_RESET_N	I	PCIe Reset Input	1.8V		Active Low
48	SYSTEM_RESET_N	I	Reset Input	1.8V		Active Low
1.8V Voltage Regulator						
28	VREG_L6_1P8	O	LDO out for 1.8V			Power

All other pins have the following characteristics:

Human Body Model (HBM):  $\pm 1000$  V

Charged Device Model (CDM) JESD22-C101-C:  $\pm 250$  V

All Antenna pins up tolerate up to  $\pm 4$  kV.



**Warning** – Do not touch the product without proper electrostatic protective equipment. The product must be handled with care, avoiding any contact with the pins because electrostatic discharge may damage the product itself.

---



## 10. PACKAGING

### 10.1. Tray

The LM960 modules are packaged on trays of 20 pieces each. These trays can be used in SMT processes for pick & place handling.

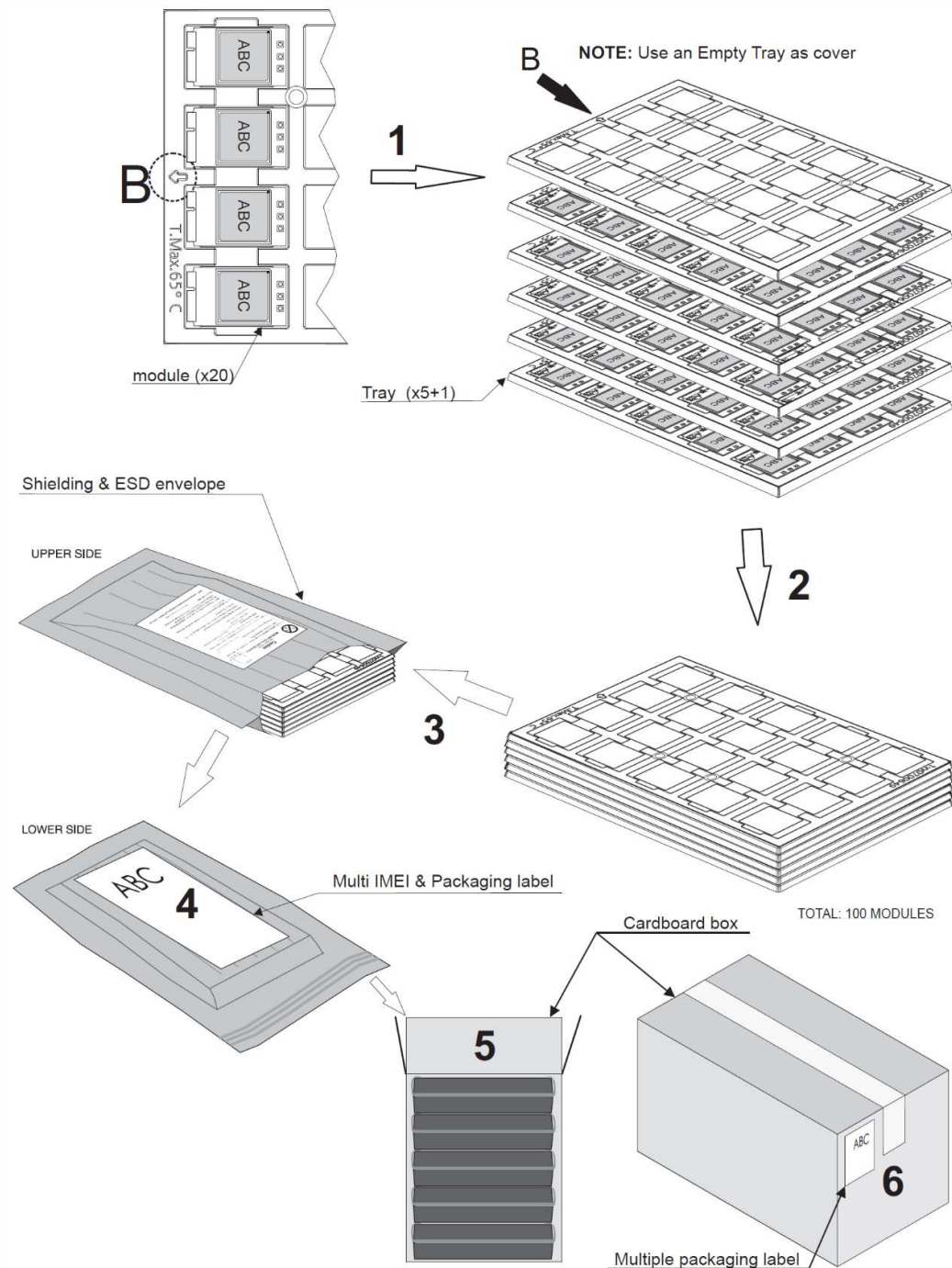



## 11. CONFORMITY ASSESSMENT ISSUES

### 11.1. Approvals

- Fully type approved confirming with RE Directive (Directive 2014/53/EU)
- CE, GCF
- FCC, IC, PTCRB
- RoHS and REACH
- Approvals for major Mobile Network Operators

### 11.2. Declaration of Conformity

The DoC is available here: [www.telit.com/RED/](http://www.telit.com/RED/)

### 11.3. FCC certificates

The FCC Certificate is available here: [www.fcc.gov/oet/ea/fccid](http://www.fcc.gov/oet/ea/fccid)

### 11.4. IC certificates

The IC Certificate is available here:

<https://sms-sgs.ic.gc.ca/equipmentSearch/searchRadioEquipments?execution=e1s1&lang=en>

### 11.5. FCC/IC Regulatory notices

#### **Modification statement**

Telit has not approved any changes or modifications to this device by the user. Any changes or modifications could void the user's authority to operate the equipment.

*Telit n'approuve aucune modification apportée à l'appareil par l'utilisateur, quelle qu'en soit la nature. Tout changement ou modification peuvent annuler le droit d'utilisation de l'appareil par l'utilisateur.*

#### **Interference statement**

This device complies with Part 15 of the FCC Rules and Industry Canada licence-exempt RSS standard(s). Operation is subject to the following two conditions: (1) this device may

not cause interference, and (2) this device must accept any interference, including interference that may cause undesired operation of the device.

*Le présent appareil est conforme aux CNR d'Industrie Canada applicables aux appareils radio exempts de licence. L'exploitation est autorisée aux deux conditions suivantes : (1) l'appareil ne doit pas produire de brouillage, et (2) l'utilisateur de l'appareil doit accepter tout brouillage radioélectrique subi, même si le brouillage est susceptible d'en compromettre le fonctionnement.*

### **RF exposure**

This equipment complies with FCC and ISED radiation exposure limits set forth for an uncontrolled environment. The antenna should be installed and operated with minimum distance of 20 cm between the radiator and your body. Antenna gain must be below:

*Cet appareil est conforme aux limites d'exposition aux rayonnements de l'ISED pour un environnement non contrôlé. L'antenne doit être installée de façon à garder une distance minimale de 20 centimètres entre la source de rayonnements et votre corps. Gain de l'antenne doit être ci-dessous:*

This radio transmitter FCCID: R17LM960 has been approved by FCC to operate with the antenna types listed below with the maximum permissible gain and required antenna impedance for each antenna type indicated. Antenna types not included in this list, having a gain greater than the maximum gain indicated for type, are strictly prohibited for use with this device.

This radio transmitter IC: 5131A-LM960 has been approved by Industry Canada to operate with the antenna types listed below with the maximum permissible gain and required antenna impedance for each antenna type indicated. Antenna types not included in this list, having a gain greater than the maximum gain indicated for that type, are strictly prohibited for use with this device.

Cet émetteur radio IC: 5131A-LM960 a été approuvé par Industrie Canada pour fonctionner avec les types d'antennes énumérés ci-dessous avec le gain maximal admissible et l'impédance d'antenne requise pour chaque type d'antenne indiqué. Types d'antennes n'est pas inclus dans cette liste, ayant un gain supérieur au gain maximal indiqué pour ce type, sont strictement interdits pour une utilisation avec cet appareil.

This transmitter must not be co-located or operating in conjunction with any other antenna or transmitter.

*L'émetteur ne doit pas être colocalisé ni fonctionner conjointement avec à autre antenne ou autre émetteur.*

#### Antenna List

No.	Manufacturer	Part No.	Antenna Type	Peak Gain
1	HNS	WE14-LF-07	Dipole	1.5 dBi for 617 ~ 960 MHz
				3.5 dBi for 1420 ~ 2200 MHz
				3 dBi for 2300 ~ 2690 MHz
2	HNS	WE14-S3-1	Dipole	4 dBi for 1420 ~ 2200 MHz
				1 dBi for 2300 ~ 2400 MHz
				3 dBi for 2498 ~ 2690 MHz
				3 dBi for 3400 ~ 5928 MHz
3	HNS	WE14-S3-2	Dipole	1 dBi for CBRS (3550 ~ 3700 MHz)

Note: The antenna connector is SMA(Male) type.

#### FCC Class B digital device notice

This equipment has been tested and found to comply with the limits for a Class B digital device, pursuant to part 15 of the FCC Rules. These limits are designed to provide reasonable protection against harmful interference in a residential installation. This equipment generates, uses and can radiate radio frequency energy and, if not installed and used in accordance with the instructions, may cause harmful interference to radio communications. However, there is no guarantee that interference will not occur in a particular installation. If this equipment does cause harmful interference to radio or television reception, which can be determined by turning the equipment off and on, the user is encouraged to try to correct the interference by one or more of the following measures:

- Reorient or relocate the receiving antenna.
- Increase the separation between the equipment and receiver.
- Connect the equipment into an outlet on a circuit different from that to which the receiver is connected.
- Consult the dealer or an experienced radio/TV technician for help.

### Labelling Requirements for the Host device

The host device shall be properly labelled to identify the modules within the host device. The certification label of the module shall be clearly visible at all times when installed in the host device, otherwise the host device must be labelled to display the FCC ID and ISED of the module, preceded by the words "Contains transmitter module", or the word "Contains", or similar wording expressing the same meaning, as follows:

*L'appareil hôte doit être étiqueté comme il faut pour permettre l'identification des modules qui s'y trouvent. L'étiquette de certification du module donné doit être posée sur l'appareil hôte à un endroit bien en vue en tout temps. En l'absence d'étiquette, l'appareil hôte doit porter une étiquette donnant le FCC ID et l'ISED du module, précédé des mots « Contient un module d'émission », du mot « Contient » ou d'une formulation similaire exprimant le même sens, comme suit :*

#### LM960

Contains FCC ID: RI7LM960

Contains IC: 5131A-LM960

#### LM960A18

Contains FCC ID: RI7LM960

Contains IC: 5131A-LM960

#### LM960A9-P

Contains FCC ID: RI7LM960A9P

Contains IC: 5131A-LM960A9P

### **CAN ICES-3 (B) / NMB-3 (B)**

This Class B digital apparatus complies with Canadian ICES-003.

*Cet appareil numérique de classe B est conforme à la norme canadienne ICES-003.*

## 11.6. RED Regulatory notices

### **RF Exposure Information (MPE)**

This device has been tested and meets applicable limits for Radio Frequency (RF) exposure. To comply with the RF exposure requirements, this module must be installed in a host platform that is intended to be operated in a minimum of 20 cm separation distance to the user.

### **OEM/Host manufacturer responsibilities**

OEM/Host manufacturers are ultimately responsible for the compliance of the Host and Module. The final product must be reassessed against all the essential requirements of the RED before it can be placed on the EU market. This includes reassessing the transmitter module for compliance with the Radio and EMF essential requirements of the RED. This module must not be incorporated into any other device or system without retesting for compliance as multi-radio and combined equipment.

### **The allowable Antenna Specification**

In all cases assessment of the final product must be met against the Essential requirements of the RE Directive Articles 3.1(a) and (b), safety and EMC respectively, as well as any relevant Article 3.3 requirements.

1. The following antenna was verified in the conformity testing, and for compliance the antenna shall not be modified. A separate approval is required for all other operating configurations, including different antenna configurations.
2. If any other simultaneous transmission radio is installed in the host platform together with this module, or above restrictions cannot be kept, a separate RF exposure assessment and CE equipment certification is required.

### **Waste Electrical and Electronic Equipment (WEEE)**



This symbol means that according to local laws and regulations your product and/or its battery shall be disposed of separately from household waste. When this product reaches its end of life, take it to a collection point designated by local authorities. Proper recycling of your product will protect human health and the environment.

## 12. SAFETY RECOMMENDATIONS

### 12.1. READ CAREFULLY

Be sure the use of this product is allowed in the country and in the environment required. The use of this product may be dangerous and has to be avoided in the following areas:

- Where it can interfere with other electronic devices in environments such as hospitals, airports, aircrafts, etc.
- Where there is risk of explosion such as gasoline stations, oil refineries, etc. It is the responsibility of the user to enforce the country regulation and the specific environment regulation.

Do not disassemble the product; any mark of tampering will compromise the warranty validity. We recommend following the instructions of the hardware user guides for correct wiring of the product. The product has to be supplied with a stabilized voltage source and the wiring has to be conformed to the security and fire prevention regulations. The product has to be handled with care, avoiding any contact with the pins because electrostatic discharges may damage the product itself. Same cautions have to be taken for the SIM, checking carefully the instruction for its use. Do not insert or remove the SIM when the product is in power saving mode.

The system integrator is responsible for the functioning of the final product; therefore, care has to be taken to the external components of the module, as well as any project or installation issue, because the risk of disturbing the LTE & WCDMA network or external devices or having impact on the security. Should there be any doubt, please refer to the technical documentation and the regulations in force. Every module has to be equipped with a proper antenna with specific characteristics. The antenna has to be installed with care in order to avoid any interference with other electronic devices and has to guarantee a minimum distance from the body (20 cm). In case this requirement cannot be satisfied, the system integrator has to assess the final product against the SAR regulation.

The European Community provides some Directives for the electronic equipment introduced on the market. All of the relevant information is available on the European Community website:

[https://ec.europa.eu/commission/index\\_en](https://ec.europa.eu/commission/index_en)

The text of the Directive 2014/35/EU regarding telecommunication equipment is available, while the applicable Directives (Low Voltage and EMC) are available at:

<http://ec.europa.eu/enterprise/sectors/electrical/>



### 13. REFERENCE TABLE OF RF BANDS CHARACTERISTICS

#### RF Bands Characteristics

Mode	Freq. Tx (MHz)	Freq. Rx (MHz)	Channels	Tx-Rx Offset
WCDMA 2100 – B1	1920 ~ 1980	2110 ~ 2170	Tx: 9612 ~ 9888 Rx: 10562 ~ 10838	190 MHz
WCDMA 1900 – B2	1850 ~ 1910	1930 ~ 1990	Tx: 9262 ~ 9538 Rx: 9662 ~ 9938	80 MHz
WCDMA AWS – B4	1710 ~ 1755	2110 ~ 2155	Tx: 1537 ~ 1738 Rx: 1312 ~ 1513	400 MHz
WCDMA 850 – B5	824 ~ 849	869 ~ 894	Tx: 4132 ~ 4233 Rx: 4357 ~ 4458	45 MHz
WCDMA 900 – B8	880 ~ 915	925 ~ 960	Tx: 2712 ~ 2863 Rx: 2937 ~ 3088	45 MHz
WCDMA 1800 Japan – B9	1750 ~ 1784.8	1845 ~ 1879.8	Tx: 8762 ~ 8912 Rx: 9237 ~ 9387	95 MHz
WCDMA 800 Japan – B19	830 ~ 845	875 ~ 890	Tx: 312 ~ 363 Rx: 712 ~ 763	45 MHz
LTE 2100 – B1	1920 ~ 1980	2110 ~ 2170	Tx: 18000 ~ 18599 Rx: 0 ~ 599	190 MHz
LTE 1900 – B2	1850 ~ 1910	1930 ~ 1990	Tx: 18600 ~ 19199 Rx: 600 ~ 1199	80 MHz
LTE 1800+ – B3	1710 ~ 1785	1805 ~ 1880	Tx: 19200 ~ 19949 Rx: 1200 ~ 1949	95 MHz
LTE AWS-1 – B4	1710 ~ 1755	2110 ~ 2155	Tx: 19950 ~ 20399 Rx: 1950 ~ 2399	400 MHz
LTE 850 – B5	824 ~ 849	869 ~ 894	Tx: 20400 ~ 20649 Rx: 2400 ~ 2649	45 MHz
LTE 2600 – B7	2500 ~ 2570	2620 ~ 2690	Tx: 20750 ~ 21449 Rx: 2750 ~ 3449	120 MHz

Mode	Freq. Tx (MHz)	Freq. Rx (MHz)	Channels	Tx-Rx Offset
LTE 900 – B8	880 ~ 915	925 ~ 960	Tx: 21450 ~ 21799 Rx: 3450 ~ 3799	45 MHz
LTE 700a – B12	699 ~ 716	729 ~ 746	Tx : 23010 ~ 23179 Rx : 5010 ~ 5179	30 MHz
LTE 700c – B13	777 ~ 787	746 ~ 756	Tx : 27210 ~ 27659 Rx : 9210 ~ 9659	-31 MHz
LTE 700PS – B14	788 ~ 798	758 ~ 768	Tx : 23280 ~ 23379 Rx : 5280 ~ 5379	-30 MHz
LTE 700b – B17	704 ~ 716	734 ~ 746	Tx: 23730 ~ 23849 Rx: 5730 ~ 5849	30 MHz
LTE 800 Lower – B18	815 ~ 830	860 ~ 875	Tx: 23850 ~ 23999 Rx: 5850 ~ 5999	45 MHz
LTE 800 Upper – B19	830 ~ 845	875 ~ 890	Tx: 24000 ~ 24149 Rx: 6000 ~ 6149	45 MHz
LTE 800 – B20	832 ~ 862	791 ~ 821	Tx: 24150 ~ 24449 Rx: 6150 ~ 6449	-41 MHz
LTE 1900+ – B25	1850 ~ 1915	1930 ~ 1995	Tx: 8040 ~ 8689 Rx: 26040 ~ 26689	80 MHz
LTE 850+ – B26	814 ~ 849	859 ~ 894	Tx: 8690 ~ 9039 Rx: 26690 ~ 27039	45 MHz
LTE 700 APT – B28	703 ~ 748	758 ~ 803	Tx: 9210 ~ 9659 Rx: 27210 ~ 27659	55 MHz
LTE 700 d – B29	Downlink only	717 ~ 728	Rx: 9660 ~ 9769	–
LTE 2300 WCS – B30	2305 ~ 2315	2350 ~ 2360	Tx: 9770 ~ 9869 Rx: 27660 ~ 27759	45 MHz
LTE 1500 L-band – B32	Downlink only	1452 ~ 1496	Rx: 9920 ~ 10359	–
LTE AWS-3 – B66	1710 ~ 1780	2110 ~ 2200	Tx: 66436 ~ 67335 Rx: 131972 ~ 132671	400 MHz

Mode	Freq. Tx (MHz)	Freq. Rx (MHz)	Channels	Tx-Rx Offset
LTE 600 – B71	663 ~ 698	617 ~ 652	Tx: 133122 ~ 133471 Rx: 68586 ~ 68935	-46 MHz
LTE TDD 2600 – B38	2570 ~ 2620		T/Rx: 37750 ~ 38250	–
LTE TDD 1900+ – B39	1880 ~ 1920		T/Rx: 38250 ~ 38649	–
LTE TDD 2300 – B40	2300 ~ 2400		T/Rx: 38650 ~ 39650	–
LTE TDD 2500 – B41	2496 ~ 2690		T/Rx: 39650 ~ 41589	–
LTE TDD 3500 – B42	3400 ~ 3600		T/Rx: 41590 ~ 43589	–
LTE TDD Unlicensed – B46	Downlink only	5150 ~ 5925	–	–
LTE TDD 3600 – B48	3550 ~ 3700		T/Rx: 55240 ~ 56739	–

## 14. ACRONYMS

TTSC	Telit Technical Support Centre
USB	Universal Serial Bus
HS	High Speed
DTE	Data Terminal Equipment
UMTS	Universal Mobile Telecommunication System
WCDMA	Wideband Code Division Multiple Access
HSDPA	High Speed Downlink Packet Access
HSUPA	High Speed Uplink Packet Access
UART	Universal Asynchronous Receiver Transmitter
HSIC	High Speed Inter Chip
SIM	Subscriber Identification Module
SPI	Serial Peripheral Interface
ADC	Analog – Digital Converter
DAC	Digital – Analog Converter
I/O	Input Output
GPIO	General Purpose Input Output
CMOS	Complementary Metal – Oxide Semiconductor
MOSI	Master Output – Slave Input
MISO	Master Input – Slave Output
CLK	Clock
MRDY	Master Ready

SRDY	Slave Ready
CS	Chip Select
RTC	Real Time Clock
PCB	Printed Circuit Board
ESR	Equivalent Series Resistance
VSWR	Voltage Standing Wave Ratio
VNA	Vector Network Analyzer
FDD	Frequency division duplex
I2C	Inter-integrated circuit
LTE	Long term evolution
SOC	System-on-Chip

## 15. DOCUMENT HISTORY

Revision	Date	Changes
0	2018-02-09	First Draft
1	2018-05-30	Updated 1.5 Related documents Updated 3.3 Pin Layout Updated 4.2 Power Consumption Updated 6 Digital Section
2	2018-07-05	Updated 2.2.1 RF Bands per Regional Variant Updated 2.6 Tx output power Updated 2.7 Rx sensitivity Updated 2.8.2 Weight Updated 4.2 Current Consumption Updated 6.6.1 USB Block Diagram Updated 6.6.2 PCIe Block Diagram Deleted 6.5.4 PCIE_WAKE_N Updated 7.1 Antenna Requirements Updated 8.3 Drawing Updated 11.5 FCC/IC Regulatory notices Updated 13 Reference Table of RF Bands Characteristic
3	2018-12-06	Updated 2 General Product Description
4	2019-03-15	Updated 3.1 Pin-out Changed PCIE_RESET_N pin description 6 Digital Section Changed description about setting GPIO as specific function. Updated 6.2 Power ON Updated 6.3 Power Off Fast Shutdown Trigger: Low Edge Trigger Updated 6.4 Reset Added 6.5 Dying Gasp Dying Gasp Trigger: Low Edge Trigger Added 6.6.5.3 Dedicated I/O Added 6.6.4.2 WAN_LED_N
5	2019-04-17	Updated 6.3.2 Fast Shutdown Timing and 2.2.1 RF Bands per Regional Variant, LM960A18 Variant introduced, various editorial changes
6	2019-06-04	Moisture Sensitivity Level paragraph added
7	2019-07-17	Band and CA combo list updated, minor editorial changes and corrections
8	2020-01-21	Moisture Sensitivity Level corrected
9	2020-01-31	Antenna port paragraph corrected (band 43 added)
10	2020-02-05	Moisture Sensitivity Declaration removed
11	2020-02-12	PCIe bus references removed
12	2020-04-01	Updated 2.7 RX Sensitivity, added lte fdd band43 sensitivity level
13	2020-05-29	Updated 2.2.1.3 2 LM960A9-P RF Bands and Carrier Aggregation Updated 2.4 Main Features, Added LM960A9-P Updated 2.8.2 Weight, Added LM960A-P Updated 7.1 Antenna requirement, Added LM960A9-P Updated 7.5 Antenna connection, Added LM960A9-P

<b>14</b>	2020-07-06	Residual references to PCIe bus removed
<b>15</b>	2020-08-13	Update 11.5. FCC/IC Regulatory notices, Added Antenna List for CBRS Added FCC/IC ID of LM960A9-P

---



# SUPPORT INQUIRIES

Link to [www.telit.com](http://www.telit.com) and contact our technical support team for any questions related to technical issues.

[www.telit.com](http://www.telit.com)



Telit Communications S.p.A.  
Via Stazione di Prosecco, 5/B  
I-34010 Sgonico (Trieste), Italy

Telit IoT Platforms LLC  
5300 Broken Sound Blvd, Suite 150  
Boca Raton, FL 33487, USA

Telit Wireless Solutions Inc.  
3131 RDU Center Drive, Suite 135  
Morrisville, NC 27560, USA

Telit Wireless Solutions Co., Ltd.  
8th Fl., Shinyoung Securities Bld.  
6, Gukjegeumyung-ro8-gil, Yeongdeungpo-gu  
Seoul, 150-884, Korea

Telit Wireless Solutions Ltd.  
10 Habarzel St.  
Tel Aviv 69710, Israel

Telit Wireless Solutions  
Tecnologia e Servicos Ltda  
Avenida Paulista, 1776, Room 10.C  
01310-921 São Paulo, Brazil

Telit reserves all rights to this document and the information contained herein. Products, names, logos and designs described herein may in whole or in part be subject to intellectual property rights. The information contained herein is provided "as is". No warranty of any kind, either express or implied, is made in relation to the accuracy, reliability, fitness for a particular purpose or content of this document. This document may be revised by Telit at any time. For most recent documents, please visit [www.telit.com](http://www.telit.com)

Copyright © 2016, Telit

Mod.0818 2017-01 Rev.0