

FCC Test Report

Product Name : LE910C1-SA

Model No. : LE910C1-SA

Applicant : Telit Wireless Solutions CO., LTD.

Address : 13th FL. Shinyoung Securities Bld., 6, Gukjegeumyung-ro8-gil,
Yeongdeungpo-gu, Seoul, 150-884, Korea

Date of Receipt : 2018/12/04

Report No. : 18C0042R-ITUSP01V00

Issued Date : 2018/12/10

Report Version : V1.0



The test results relate only to the samples tested.

The test results shown in the test report are traceable to the national/international standard through the calibration of the equipment and evaluated measurement uncertainty herein.

This report must not be used to claim product endorsement by TAF, NIST or any agency of the Government.

The test report shall not be reproduced except in full without the written approval of DEKRA Testing and Certification Co., Ltd..

Test Report Certification

Issued Date : 2018/12/10

Report No. : 18C0042R-ITUSP01V00



Product Name : LE910C1-SA
Applicant : Telit Wireless Solutions CO., LTD.
Address : 13th FL. Shinyoung Securities Bld., 6, Gukjegeumyung-ro8-gil,
Yeongdeungpo-gu, Seoul, 150-884, Korea
Manufacturer : Telit Wireless Solutions CO., LTD.
Model No. : LE910C1-SA
EUT Voltage : DC 3.8V
Trade Name : 
Applicable Standard : FCC CFR Title 47 Part 15 Subpart B: 2017 Class B,
CISPR 22: 2008, ICES-003 Issue 6: 2016 Class B,
ANSI C63.4: 2014
Test Result : Complied
Laboratory Name : Hsin Chu Laboratory
Address : No.372-2, Sec. 4, Zhongxing Rd., Zhudong Township, Hsinchu
County 310, Taiwan, R.O.C.
TEL: +886-3-582-8001 / FAX: +886-3-582-8958

Documented By : 
(Demi Chang / Senior Engineering Adm. Specialist)

Tested By : 
(Horner Liu / Senior Engineer)

Approved By : 
(Arthur Liu / Deputy Manager)

Laboratory Information

We , **DEKRA Testing and Certification Co., Ltd.**, are an independent EMC and safety consultancy that was established the whole facility in our laboratories. The test facility has been accredited/accepted (audited or listed) by the following related bodies in compliance with ISO 17025, EN 45001 and specified testing scopes:

Taiwan R.O.C.	:	BSMI, NCC, TAF
USA	:	FCC
Japan	:	VCCI

The related certificate for our laboratories about the test site and management system can be downloaded from DEKRA Testing and Certification Co., Ltd. Web Site :

<http://www.dekra.com.tw/english/about/certificates.aspx?bval=5>

The address and introduction of DEKRA Testing and Certification Co., Ltd. laboratories can be founded in our Web site : http://www.dekra.com.tw/index_en.aspx

If you have any comments, Please don't hesitate to contact us. Our test sites as below:

- 1 No. 75-2, 3rd Lin, WangYe Keng, Yonghxing Tsuen, Qionglin Shiang, Hsinchu County 307, Taiwan (R.O.C.)
TEL:+886-3-592-8858 / FAX:+886-3-592-8859 E-Mail : info.tw@dekra.com
- 2 No.372, Sec. 4, Zhongxing Rd., Zhudong Township, Hsinchu County 31061, Taiwan
TEL: +886-3-582-8001 / FAX: +886-3-582-8958 E-Mail : info.tw@dekra.com
- 3 No.372-2, Sec. 4, Zhongxing Rd., Zhudong Township, Hsinchu County 31061, Taiwan
TEL: +886-3-582-8001 / FAX: +886-3-582-8958 E-Mail : info.tw@dekra.com

TABLE OF CONTENTS

Description	Page
1. General Information	5
1.1. EUT Description	5
1.2. Mode of Operation	6
1.3. Tested System Details	7
1.4. Configuration of Tested System	7
1.5. EUT Exercise Software	7
2. Technical Test.....	8
2.1. Summary of Test Result	8
2.2. List of Test Equipment	9
2.3. Measurement Uncertainty	10
2.4. Test Environment	10
3. Conducted Emissions	11
3.1. Test Specification	11
3.2. Test Setup	11
3.3. Limit.....	11
3.4. Test Procedure	12
3.5. Test Result	12
4. Radiated Emissions	13
4.1. Test Specification	13
4.2. Test Setup	13
4.3. Limit.....	14
4.4. Test Procedure	15
4.5. Test Result	16
4.6. Test Photograph	20
5. Attachment	22
EUT Photograph	22

1. General Information

1.1. EUT Description

Product Name	LE910C1-SA
Trade Name	
Test Model No.	LE910C1-SA
HW Version	1.0
SW Version	25.20.312-B006

Note:

1. This EUT is a LE910C1-SA.

1.2. Mode of Operation

DEKRA has verified the construction and function in typical operation. All the test modes were carried out with the EUT in normal operation, which was shown in this test report and defined as:

Pre-Test Mode	
Mode 1: Normal Operation	
Final Test Mode	
Emission	Mode 1: Normal Operation

1.3. Tested System Details

The types for all equipments, plus descriptions of all cables used in the tested system (including inserted cards) are:

Product	Manufacturer	Model No.	Serial No.	FCC ID	Power Cord
1 Fixture	N/A	N/A	N/A	--	--
2 Wideband Radio Communication Tester	R&S	CMW500	106071	DoC	--
3 Horn Antenna	Schwarzbeck	BBHA 9170	202	DoC	--

1.4. Configuration of Tested System

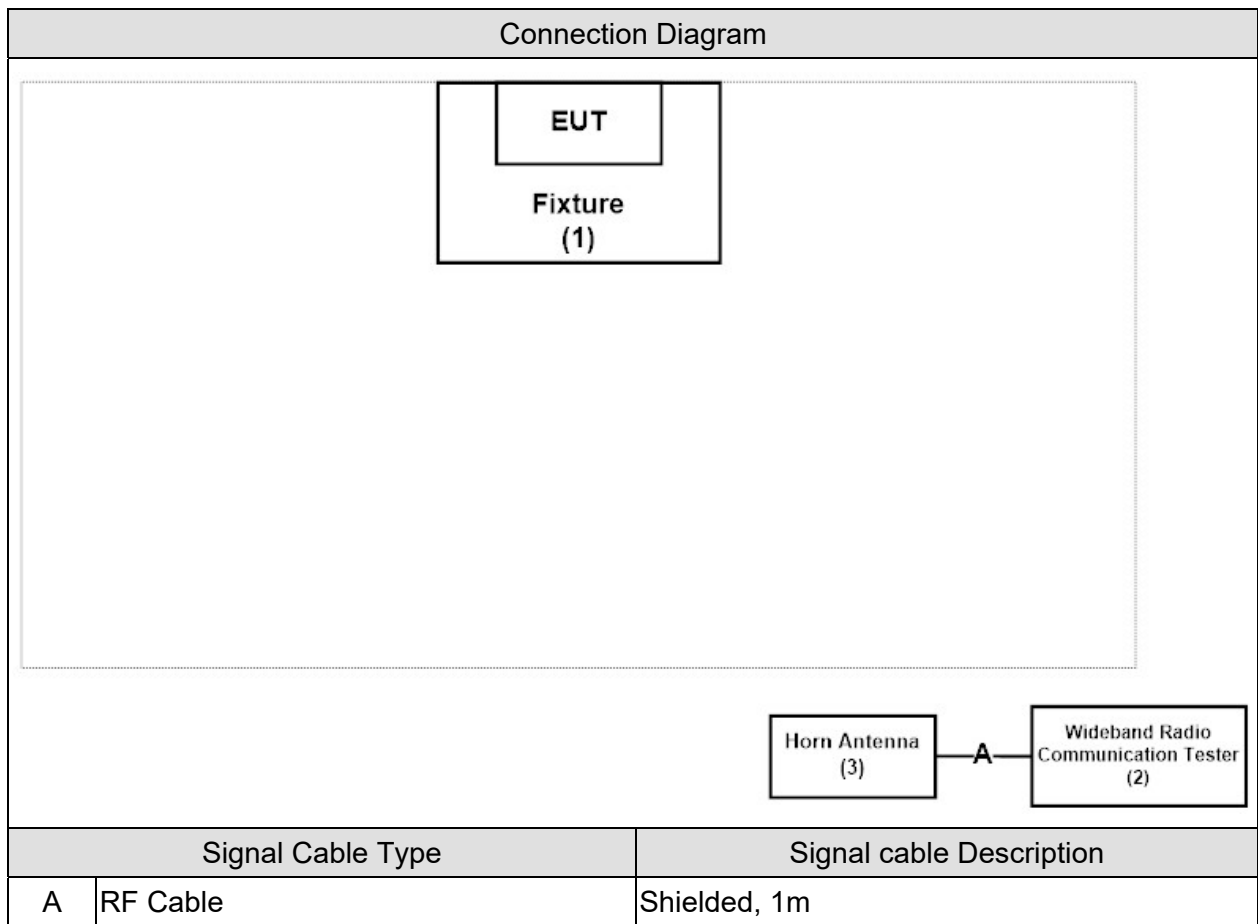

1.5. EUT Exercise Software

1	Test system is in accord with EUT user manual. (refer to 1.4 configuration of tested system)
2	Turn on the power of all equipment.
3	The EUT link with base station and it will continue receive the signal from LTE function.
4	Verify that the EUT works properly.

2. Technical Test

2.1. Summary of Test Result

- No deviations from the test standards
- Deviations from the test standards as below description:

Emission				
Performed Item	Normative References	Test Performed	Deviation	Test Site
Conducted Emissions	FCC CFR Title 47 Part 15 Subpart B: 2017, CISPR 22: 2008, ANSI C63.4: 2014	No	No	--
Radiated Emissions	FCC CFR Title 47 Part 15 Subpart B: 2017, CISPR 22: 2008, ANSI C63.4: 2014	Yes	No	2

Note: Test Site information refers to Laboratory Information.

2.2. List of Test Equipment

Radiated Emissions / CB1-H (Under 1GHz)

Instrument	Manufacturer	Model No.	Serial No.	Cal. Date	Next Cal. Date
EMI Test Receiver	R&S	ESR7	101762	2018/11/22	2019/11/21
EMI Test Receiver	R&S	ESR7	101761	2018/11/19	2019/11/18
Pre-Amplifier	QuieTek	AP-025C	CHM-0610033	2018/08/03	2019/08/02
Pre-Amplifier	QuieTek	AP-025C	CHM-0503002	2018/07/27	2019/07/26
Bilog Antenna	Schaffner	CBL6112B	2891	2018/08/15	2019/08/14
Bilog Antenna	Schaffner Chase	CBL6112B	2914	2018/08/15	2019/08/14
Coaxial cable	Suhner	SF106_SF104_S600	10m-1	2018/08/15	2019/08/14
Coaxial cable	Suhner	SF106_SF104_S600	10m-2	2018/08/15	2019/08/14
Coaxial cable	Suhner	SF106_SF104	3m-1	2018/08/15	2019/08/14
Coaxial cable	Suhner	SF106_SF104	3m-2	2018/08/15	2019/08/14
DEKRA-EMI V1.0	Dekra	Version 1.0	CB1-H	N/A	N/A

Radiated Emissions / CB4-H (Above 1GHz)

Instrument	Manufacturer	Model No.	Serial No.	Cal. Date	Next Cal. Date
Signal & Spectrum Analyzer	R&S	FSV40	101049	2018/01/10	2019/01/09
Horn Antenna	Schwarzbeck	BBHA 9120D	312	2018/09/26	2019/09/25
Horn Antenna	Schwarzbeck	BBHA 9170	202	2018/01/31	2019/01/30
Pre-Amplifier	EMCI	EMC11830I	980367	2018/01/31	2019/01/30
Pre-Amplifier	Dekra	AP-400C	201801231	2018/12/05	2019/12/04
Coaxial Cable	Suhner	SF104_SF104_ SF104_SF102	CB4-H	2018/08/15	2019/08/14
QuieTek EMI	Dekra	Version 2	CB4-H	N/A	N/A

2.3. Measurement Uncertainty

Radiated Emissions (Under 1GHz)

The measurement uncertainty is evaluated as ± 3.43 dB.

Radiated Emissions (Above 1GHz)

The measurement uncertainty is evaluated as ± 3.65 dB.

2.4. Test Environment

Performed Item	Items	Required	Actual
Radiated Emissions	Temperature (°C)	15-35	26
	Humidity (%RH)	25-75	65
	Barometric pressure (mbar)	860-1060	950-1000

3. Conducted Emissions

3.1. Test Specification

According to Standard : FCC Part 15 Subpart B, ANSI C63.4

3.2. Test Setup

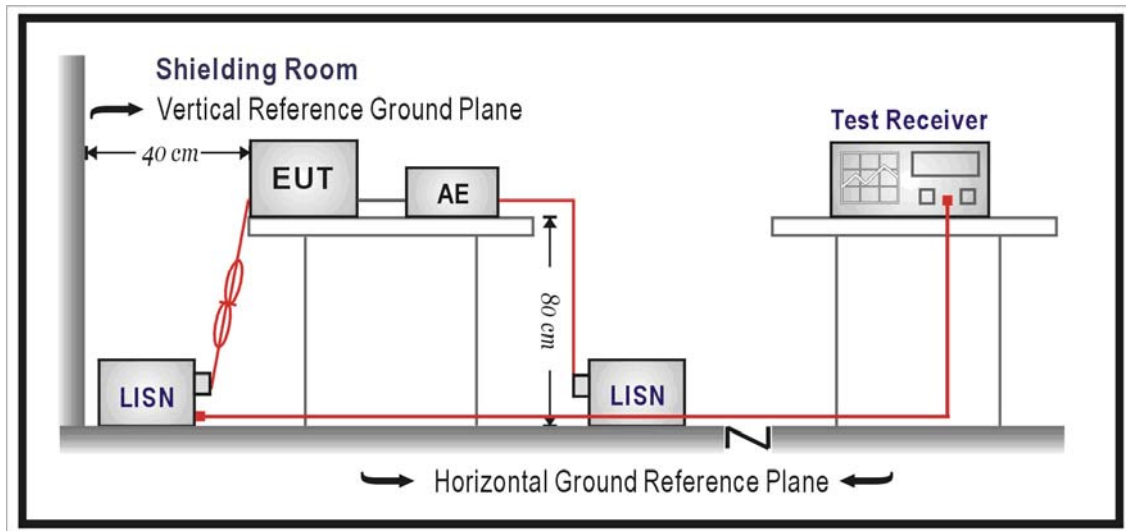

3.3. Limit

Limits		
Frequency (MHz)	QP (dBuV)	AV (dBuV)
0.15 – 0.50	66 – 56	56 – 46
0.50 – 5.0	56	46
5.0 – 30	60	50

Remarks: In the above table, the tighter limit applies at the band edges.

3.4. Test Procedure

The EUT and simulators are connected to the main power through a line impedance stabilization network (L.I.S.N.). This provides a 50 ohm /50uH coupling impedance for the measuring equipment. The peripheral devices are also connected to the main power through a LISN that provides a 50ohm/50uH coupling impedance with 50ohm termination.

(Please refers to the block diagram of the test setup and photographs.)

Both sides of A.C. line are checked for maximum conducted interference. In order to find the maximum emission, the relative positions of equipment and all of the interface cables must be changed on conducted measurement.

Conducted emissions were invested over the frequency range from 0.15MHz to 30MHz using a receiver bandwidth of 9kHz.

3.5. Test Result

Owing to the DC operation of EUT, this test item is not performed.

4. Radiated Emissions

4.1. Test Specification

According to EMC Standard : FCC Part 15 Subpart B, ANSI C63.4

4.2. Test Setup

Under 1GHz Test Setup

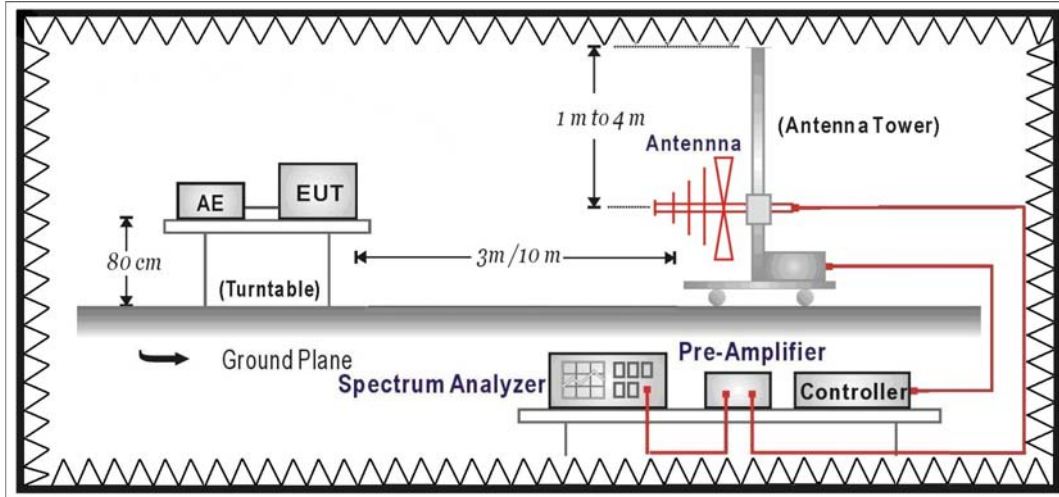

Above 1GHz Test Setup

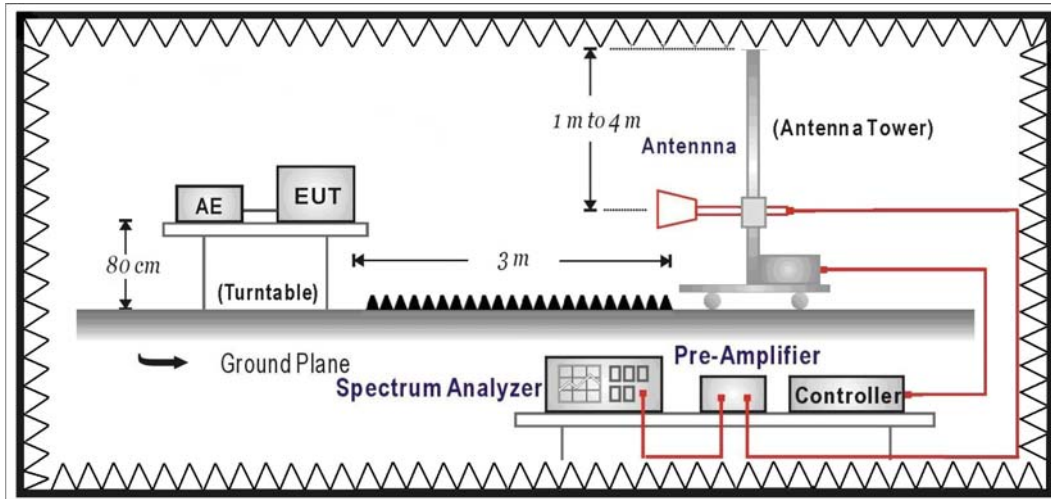

4.3. Limit

Under 1GHz test shall not exceed the following value:

Limits		
Frequency (MHz)	Distance (m)	dBuV/m
30 – 230	10	30
230 – 1000	10	37

Limits		
Frequency (MHz)	Distance (m)	dBuV/m
30 – 88	10	40
88 – 216	10	43.5
216 – 960	10	46
Above 960	10	54

Remark:

1. The tighter limit shall apply at the edge between two frequency bands.
1. Distance refers to the distance in meters between the measuring instrument antenna and the closed point of any part of the device or system.
2. RF Voltage (dBuV/m) = 20 log RF Voltage (uV/m)

Above 1GHz test shall not exceed the following value:

FCC Part 15 Subpart B Paragraph 15.109 Limits			
Frequency (MHz)	Distance (m)	Peak (dBuV/m)	Average (dBuV/m)
Above 1000	3	74	54

Remark:

1. Distance refers to the distance in meters between the measuring instrument antenna and the closed point of any part of the device or system.

4.4. Test Procedure

The EUT and its simulators are placed on a turn table which is 0.8 meter above ground.

The turn table can rotate 360 degrees to determine the position of the maximum emission level and the antenna can move up and down between 1 meter and 4 meters to find out the maximum emission level.

Both horizontal and vertical polarization of the antenna are set on measurement. In order to find the maximum emission, all of the interface cables must be manipulated on radiated measurement.

For an unintentional radiator, including a digital device, the spectrum shall be investigated from the lowest radio frequency signal generated or used in the device, without going below the lowest frequency for which a radiated emission limit is specified, up to the frequency shown in the following table:

Highest frequency generated or used in the device or on which the device operates or tunes (MHz)	Upper frequency of measurement range (MHz)
Below 1.705	30
1.705 – 108	1000
108 – 500	2000
500 – 1000	5000
Above 1000	5 th harmonic of the highest frequency or 40 GHz, whichever is lower

On any frequency or frequencies below or equal to 1000 MHz, the radiated limits shown are based on measuring equipment employing a quasi-peak detector function and above 1000 MHz, the radiated limits shown are based measuring equipment employing an average detector function.

When average radiated emission measurement are included emission measurement Above 1000 MHz, there also is a limit on the radio frequency emissions, as measured using instrumentation with a peak detector function, corresponding to 20 dB above the maximum permitted average limit.

For class A, the measurement distance between the EUT and antenna is 10 meters for under 1GHz and 3 meters for above 1GHz.

For class B, the measurement distance between the EUT and antenna is 10 meters for under 1GHz and 3 meters for above 1GHz.

The bandwidth below 1GHz setting on the field strength meter is 120 kHz and above 1GHz is 1MHz.

4.5. Test Result

Site :	CB1-H	Engineer :	hornet
Model No :	LE910C1-SA	Test Date :	2018/12/5
Test Voltage :	DC 3.8V	Polarity :	Horizontal
Test Mode :	Mode 1: Normal Operation		
Note :			

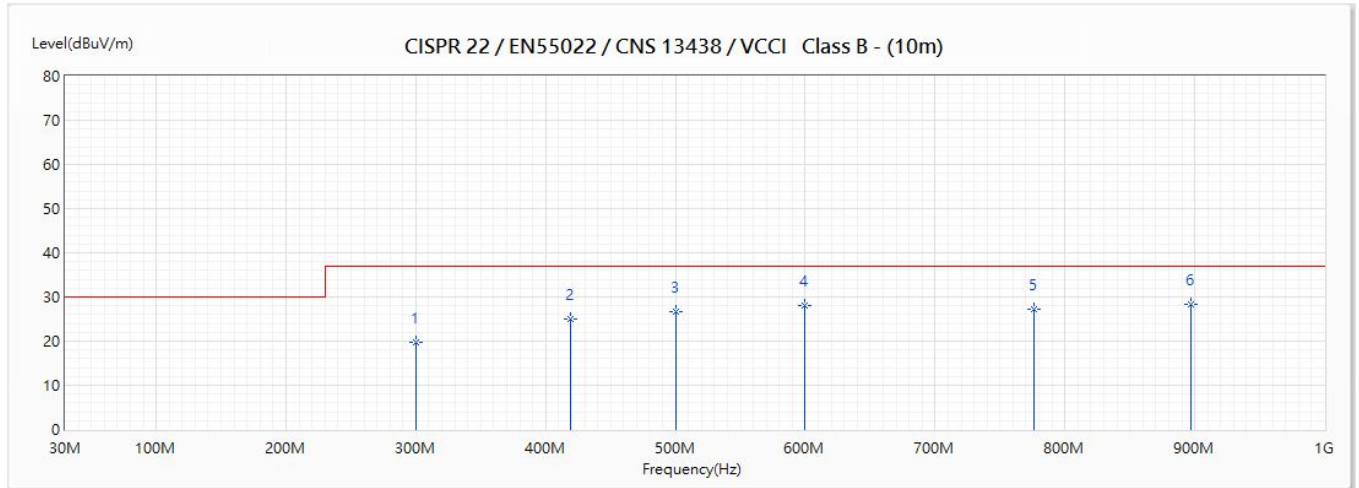

No	Frequency (MHz)	Emission Level (dBuV/m)	Limit (dBuV/m)	Margin (dB)	Reading Level (dBuV)	Correct Factor (dB)	Detector Type
1	299.903	19.64	37.00	-17.36	31.29	-11.65	QP
2	418.97	25.06	37.00	-11.94	30.68	-5.62	QP
3	499.965	26.80	37.00	-10.20	32.85	-6.05	QP
4	599.39	28.02	37.00	-8.98	29.73	-1.71	QP
5	775.93	27.27	37.00	-9.73	29.90	-2.63	QP
* 6	897.18	28.33	37.00	-8.67	28.75	-0.42	QP

Remark:

1. " * ", means this data is the worst emission level.
2. Emission Level = Reading Level + Correct Factor.
3. Margin = Emission Level - Limit.

Site :	CB4-H	Engineer :	Hornet
Model No :	LE910C1-SA	Test Date :	2018/12/7
Test Voltage :	DC 3.8V	Polarity :	Horizontal
Test Mode :	Mode 1: Normal Operation		
Note :			

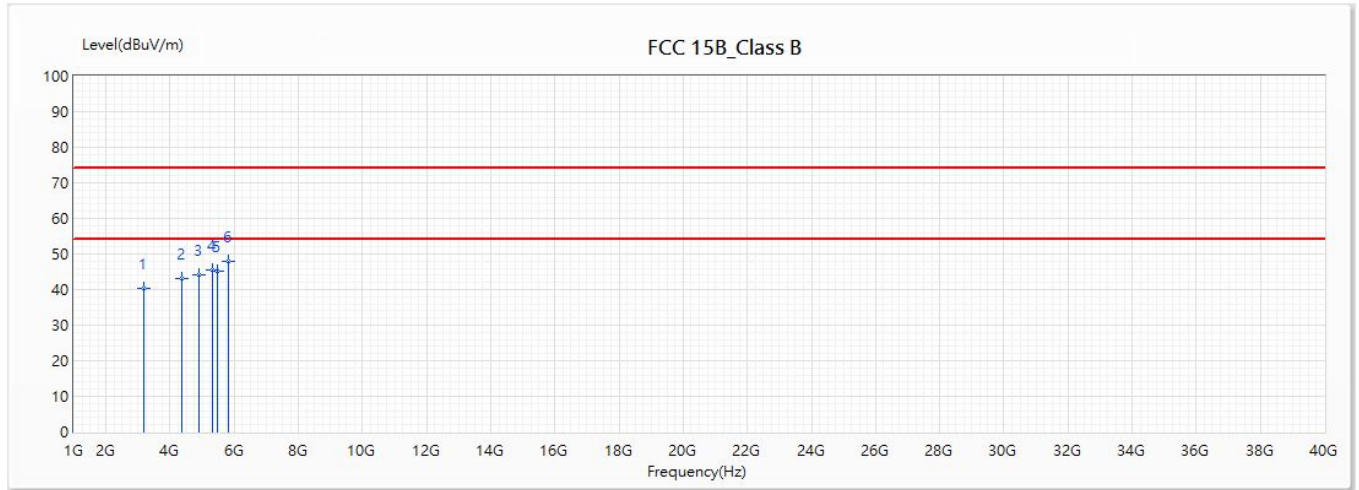

No	Frequency (MHz)	Emission Level (dBuV/m)	Limit (dBuV/m)	Margin (dB)	Reading Level (dBuV)	Correct Factor (dB)	Detector Type
1	3187.5	40.38	74.00	-33.62	37.79	2.59	PK
2	4352.5	43.15	74.00	-30.85	36.44	6.71	PK
3	4913.75	44.19	74.00	-29.81	35.52	8.67	PK
4	5311.25	45.48	74.00	-28.52	36.24	9.24	PK
5	5476.25	45.33	74.00	-28.67	35.81	9.52	PK
* 6	5812.5	47.93	74.00	-26.07	36.39	11.54	PK

Remark:

1. " * ", means this data is the worst emission level.
2. Emission Level = Reading Level + Correct Factor.
3. Margin = Emission Level - Limit.

Site :	CB1-H	Engineer :	hornet
Model No :	LE910C1-SA	Test Date :	2018/12/5
Test Voltage :	DC 3.8V	Polarity :	Vertical
Test Mode :	Mode 1: Normal Operation		
Note :			

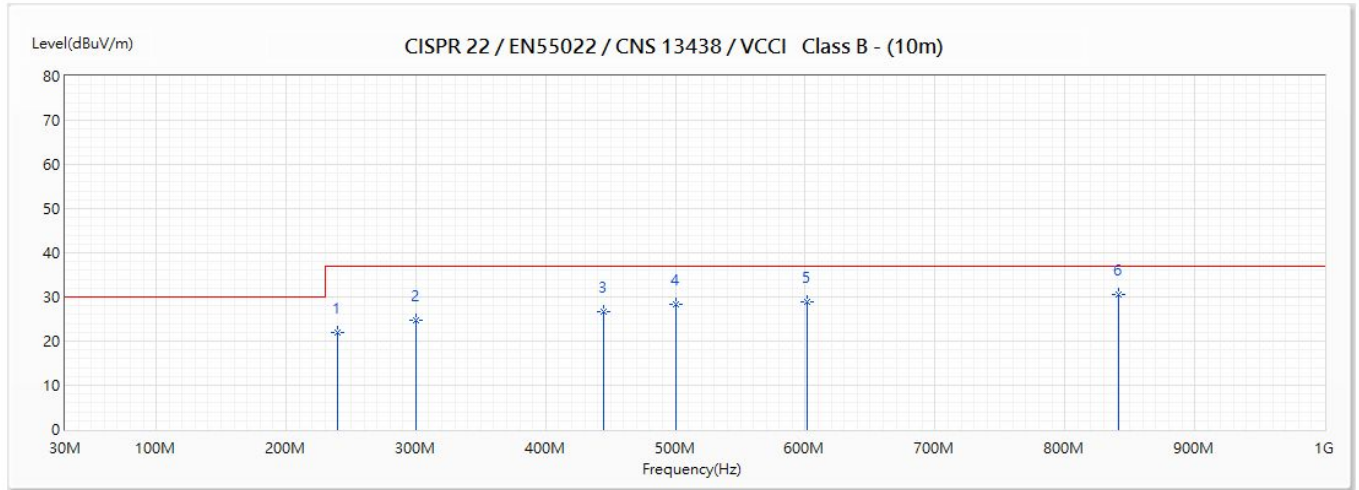

No	Frequency (MHz)	Emission Level (dBuV/m)	Limit (dBuV/m)	Margin (dB)	Reading Level (dBuV)	Correct Factor (dB)	Detector Type
1	240.005	21.97	37.00	-15.03	32.92	-10.95	QP
2	299.903	24.82	37.00	-12.18	35.24	-10.42	QP
3	444.433	26.66	37.00	-10.34	32.12	-5.46	QP
4	499.965	28.24	37.00	-8.76	35.73	-7.49	QP
5	601.088	28.98	37.00	-8.02	31.64	-2.66	QP
* 6	841.405	30.61	37.00	-6.39	32.62	-2.01	QP

Remark:

1. " * ", means this data is the worst emission level.
2. Emission Level = Reading Level + Correct Factor.
3. Margin = Emission Level - Limit.

Site :	CB4-H	Engineer :	Hornet
Model No :	LE910C1-SA	Test Date :	2018/12/7
Test Voltage :	DC 3.8V	Polarity :	Vertical
Test Mode :	Mode 1: Normal Operation		
Note :			

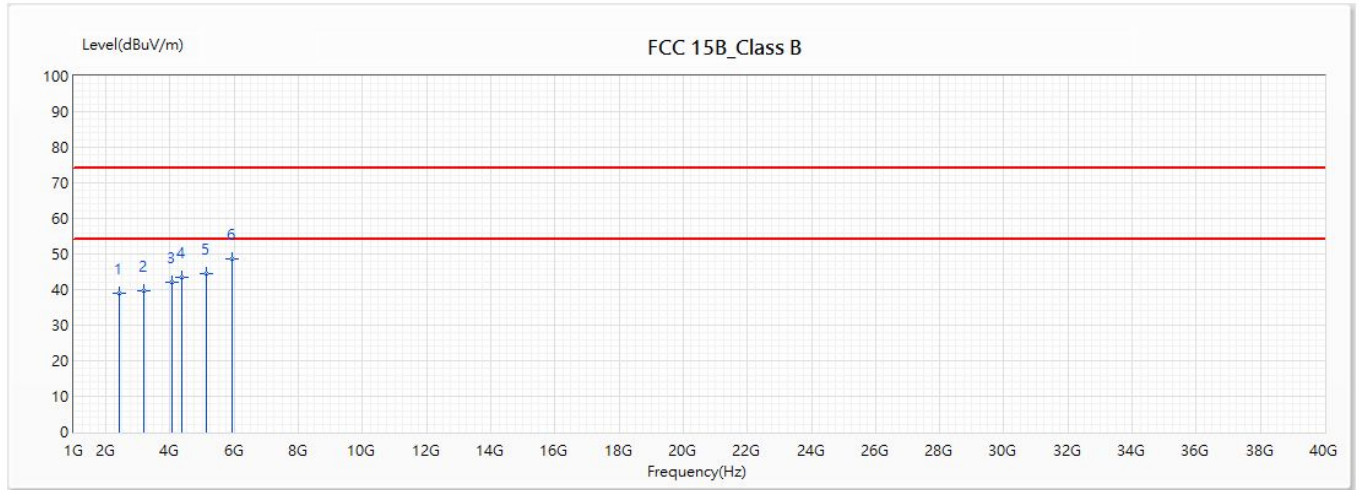

No	Frequency (MHz)	Emission Level (dBuV/m)	Limit (dBuV/m)	Margin (dB)	Reading Level (dBuV)	Correct Factor (dB)	Detector Type
1	2423.75	39.02	74.00	-34.98	39.42	-0.40	PK
2	3192.5	39.62	74.00	-34.38	37.00	2.62	PK
3	4055	42.17	74.00	-31.83	36.42	5.75	PK
4	4357.5	43.35	74.00	-30.65	36.62	6.73	PK
5	5117.5	44.60	74.00	-29.40	35.50	9.10	PK
* 6	5926.25	48.50	74.00	-25.50	36.19	12.31	PK

Remark:

1. " * ", means this data is the worst emission level.
2. Emission Level = Reading Level + Correct Factor.
3. Margin = Emission Level - Limit.

4.6. Test Photograph

Test Mode : Mode 1: Normal Operation

Description : Front View of Radiated Emissions Test Setup



Test Mode : Mode 1: Normal Operation

Description : Back View of Radiated Emissions Test Setup

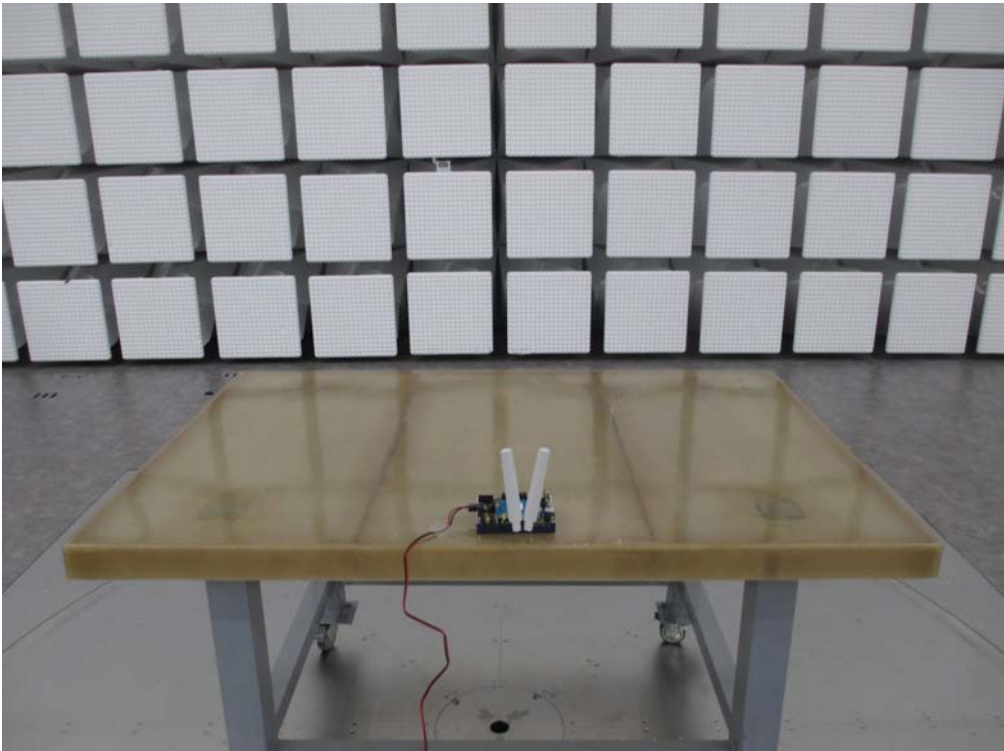

Test Mode : Mode 1: Normal Operation

Description : Front View of Radiated Emissions Test Setup (Horn)

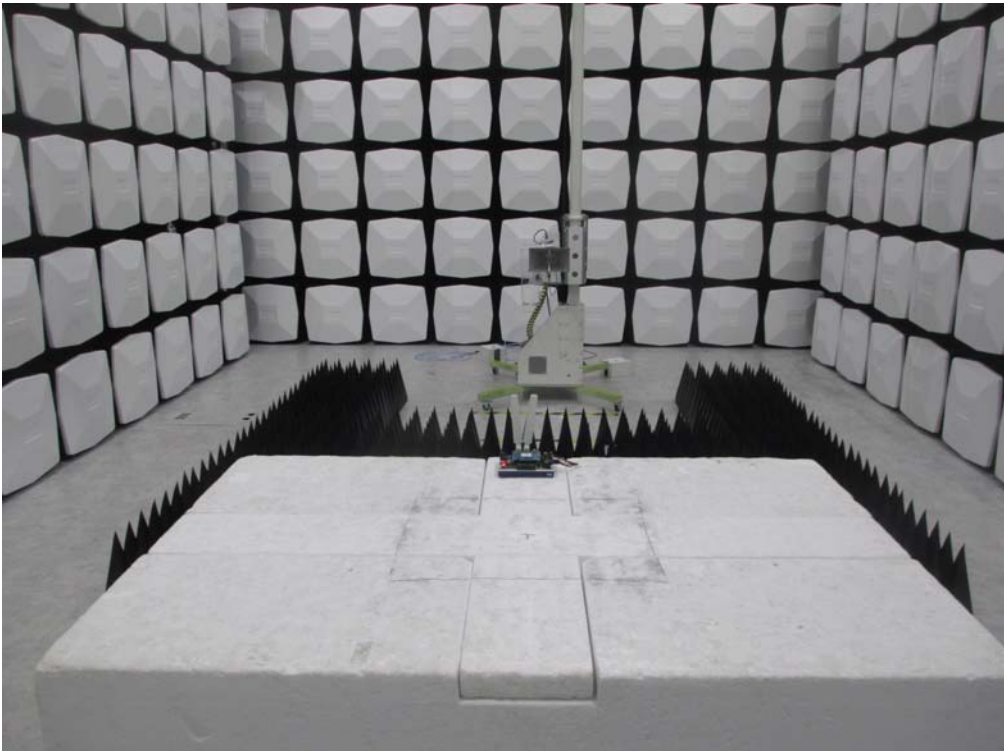

Test Mode : Mode 1: Normal Operation

Description : Back View of Radiated Emissions Test Setup (Horn)

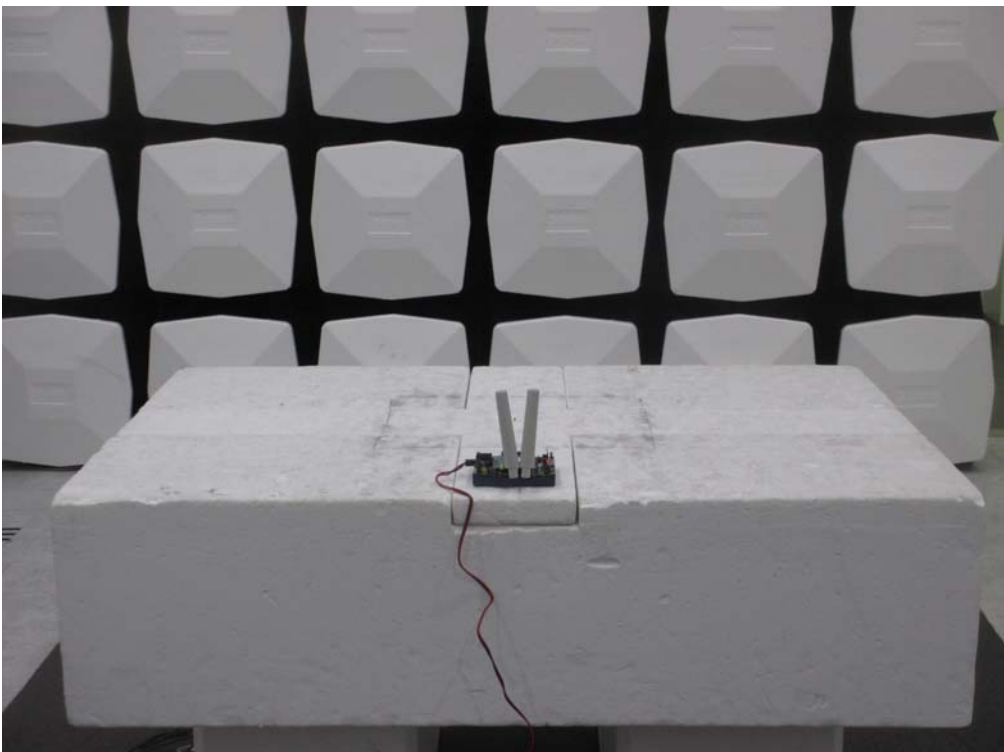

5. Attachment
➤ **EUT Photograph**
(1) EUT Photo

