

FCC/ISED Partial Test Report

Product Name : LE910C1-SA
Trade Name : 
Model No. : LE910C1-SA
FCC ID : RI7LE910C1SA
IC ID : 5131A-LE910C1SA

Applicant : Telit Wireless Solutions CO., LTD.
Address : 13th FL. Shinyoung Securities Bld., 6, Gukjegeumyung-ro8-gil,
Yeongdeungpo-gu, Seoul, 150-884, Korea

Date of Receipt : Dec. 04, 2018
Issued Date : Mar. 05, 2018
Report No. : 18C0042R-HPUSP35V00
Report Version : V3.0

The test results relate only to the samples tested.
The test report shall not be reproduced except in full without the written approval of DEKRA Testing and Certification Co., Ltd..

Test Report Certification

Issued Date : Mar. 05, 2018

Report No. : 18C0042R-HPUSP35V00



Product Name : LE910C1-SA
 Applicant : Telit Wireless Solutions CO., LTD.
 Address : 13th FL. Shinyoung Securities Bld., 6, Gukjegeumyung-ro8-gil, Yeongdeungpo-gu, Seoul, 150-884, Korea
 Manufacturer : Telit Wireless Solutions CO., LTD.
 Address : 13th FL. Shinyoung Securities Bld., 6, Gukjegeumyung-ro8-gil, Yeongdeungpo-gu, Seoul, 150-884, Korea
 Trade name :

Model No. : LE910C1-SA
 FCC ID : RI7LE910C1SA
 IC ID : 5131A-LE910C1SA
 EUT Voltage : DC 3.8V
 Testing Voltage : DC 3.8V
 Applicable Standard : FCC CFR Title 47 Part 24 Subpart E
 FCC CFR Title 47 Part 27 Subpart L, Subpart F
 ANSI/TIA-603
 KDB 971168 D01 Power Meas License Digital Systems v03
 RSS-GEN Issue5, RSS-130 Issue1,
 RSS-133 Issue6, RSS-139 Issue3

Test Lab : Hsin Chu Laboratory
 Address : No.372-2, Sec. 4, Zhongxing Rd., Zhudong Township, Hsinchu County 310, Taiwan, R.O.C.
 TEL: +886-3-582-8001 / FAX: +886-3-582-8958

Test Result : Complied

Documented By :

(Demi Chang / Senior Engineering Adm. Specialist)

Tested By :

(Clemens Fang / Engineer)

Approved By :

(Roy Wang / Director)

Revision History

Report No.	Version	Description	Issued Date
18C0042R-HPUSP35V00	V1.0	This is a partial report, we only tested the output power and spurious emissions by customer's requirements.	Dec. 20, 2018
18C0042R-HPUSP35V00	V2.0	Add 26dB & 99% Occupied Bandwidth test.	Jan. 07, 2018
18C0042R-HPUSP35V00	V3.0	Remove 26dB & 99% Occupied Bandwidth test.	Mar. 05, 2018

TABLE OF CONTENTS

Description	Page
1. General Information	5
1.1. EUT Description.....	5
1.2. Mode of Operation	6
1.3. Tested System Details	7
1.4. Configuration of Tested System	7
1.5. EUT Exercise Software.....	7
2. Technical Test	8
2.1. Summary of Test Result.....	8
2.2. Test Environment	13
2.3. List of Test Equipment.....	14
2.4. Uncertainty.....	15
3. RF Output Power	16
3.1. Test Setup.....	16
3.2. Test Procedure.....	16
3.3. Test Method	16
3.4. Test Result	17
4. Spurious Emissions	87
4.1. Test Setup.....	87
4.2. Test Procedure.....	88
4.3. Test Method	88
4.4. Test Result.....	89
5. Attachment 1	120
Test Setup Photograph	120
Attachment 2.....	122
EUT External Photograph.....	122
Attachment 3.....	126
EUT Internal Photograph	126

1. General Information

1.1. EUT Description

Product Name	LE910C1-SA
Trade Name	
Model No.	LE910C1-SA
Uplink Frequency Range (MHz)	LTE Band 2: 1850~1910 LTE Band 4: 1710~1755 LTE Band 12: 699~716 LTE Band 14: 788~798 LTE Band 66: 1710~1780
Downlink Frequency Range (MHz)	LTE Band 2: 1930~1990 LTE Band 4: 2110~2115 LTE Band 12: 729~746 LTE Band 14: 758~768 LTE Band 66: 2110~2200
Modulation	QPSK /16QAM
HW Version	1.0
SW Version	25.20.312-B006

Accessories Information	
Antenna	1 Pcs

Antenna Information	
Product Name	Hankook
Model No.	WE14-LF-07
Antenna Type	Dipole Antenna
Antenna Gain	Band 2/4/66: 3.5dBi Band 12/14: 3dBi

Note:

1. This LE910C1-SA support LTE Band 2/4/12/14/66.
2. Regards to the frequency band operation: the lowest, middle and highest frequency of channel were selected to perform the test, then shown on this report.

1.2. Mode of Operation

DEKRA has verified the construction and function in typical operation. All the test modes were carried out with the EUT in normal operation, which was shown in this test report and defined as:

Test Mode
Mode 1: LTE Band 2
Mode 2: LTE Band 4
Mode 3: LTE Band 12
Mode 4: LTE Band 14
Mode 5: LTE Band 66

1.3. Tested System Details

The types for all equipment, plus descriptions of all cables used in the tested system (including inserted cards) are:

Product	Manufacturer	Model No.	Serial No.	FCC ID	Power Cord
1 Horn Antenna	ELECTRO METRICS	EM-6961	103326	DoC	--
2 Base Station	R&S	CMW500	106071	DoC	--

1.4. Configuration of Tested System

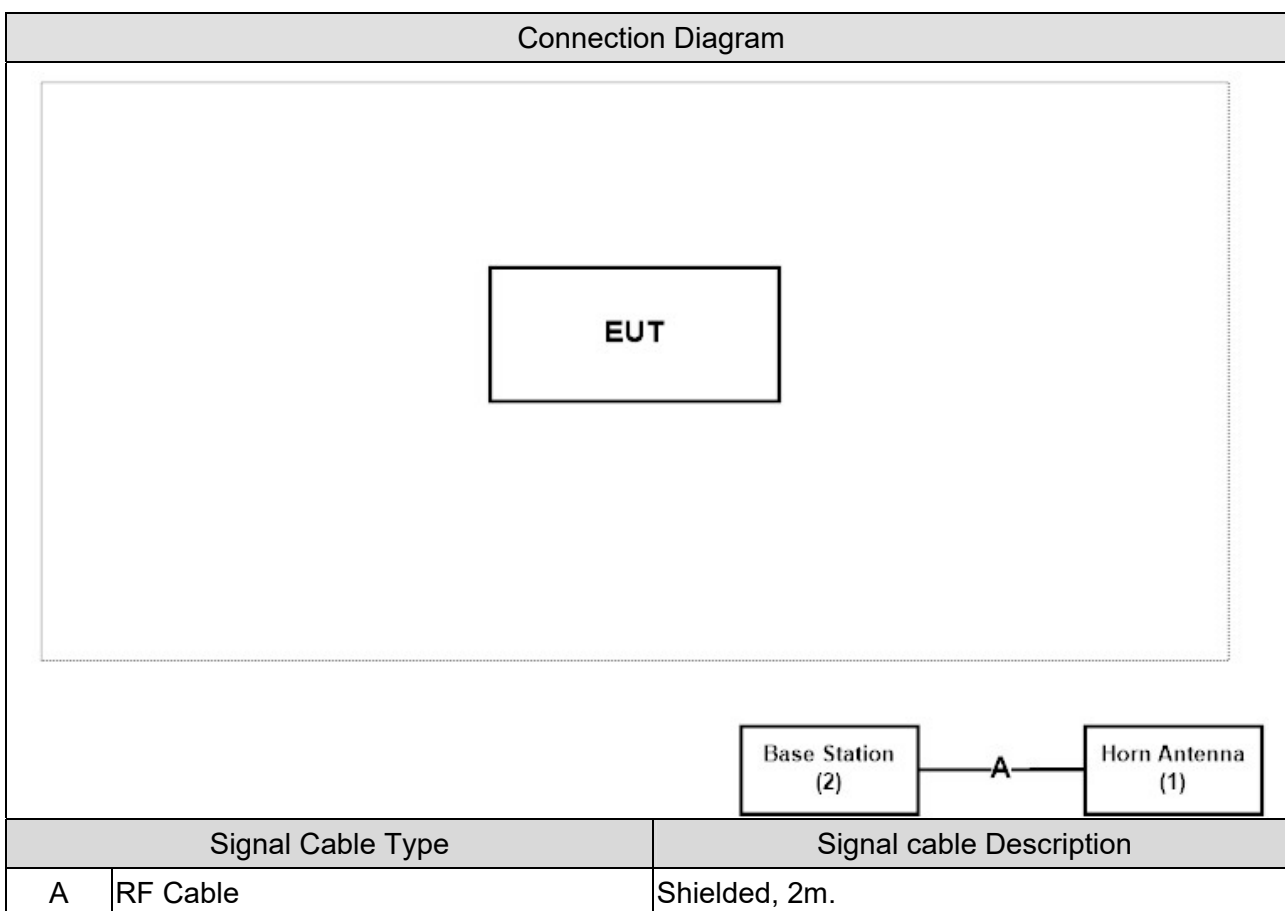

1.5. EUT Exercise Software

1	Setup the EUT and simulators as shown on 1.4.
2	Turn on the power of all equipment. Horn link with base station.
3	The EUT link with base station and it will continue receive the signal.
4	Repeat the above procedure.

2. Technical Test

2.1. Summary of Test Result

B2

Uplink: 1850-1910MHz

Downlink: 1930-1990MHz

LTE B2					
FCC Part 24 Subpart E					
Industry Canada RSS-133, issue 6, Industry Canada RSS-GEN					
Test item	FCC Reference section	FCC Limit	IC Reference section	IC Limit	Result
RF Output Power	§2.1033 §2.1046 §24.232	<2 Watts	§6.4	<2 Watts	Pass
Occupied Bandwidth	§2.1049	N/A	RSS-GEN §4.2	N/A	N/A
Peak-to-average power ratio	§24.232	<13 dB	§6.4	<13 dB	N/A
Spurious Emissions	§2.1053 §24.238	<-13 dBm	§6.5	<-13 dBm	Pass
Spurious Emissions at Antenna Terminals	§27.238	<-13 dBm	§6.5	<-13 dBm	N/A
Frequency Stability	§2.1055 §24.235	<±2.5 ppm	§6.3	<±2.5 ppm	N/A

B4

Uplink: 1710-1755MHz

Downlink: 2100-2155MHz

LTE B4					
FCC Part 27 Subpart L					
Industry Canada RSS-139, issue 3, Industry Canada RSS-GEN					
Test item	FCC Reference section	FCC Limit	IC Reference section	IC Limit	Result
RF Output Power	§2.1033 §2.1046 §27.50	<1 Watt	§6.5	<1 Watt	Pass
Occupied Bandwidth	§2.1049	N/A	RSS-GEN §4.2	N/A	N/A
Peak-to-average power ratio	§27.50	<13 dB	§6.5	<13 dB	N/A
Spurious Emissions	§2.1053 §27.53	<-13 dBm	§6.6	<-13 dBm	Pass
Spurious Emissions at Antenna Terminals	§27.53	<-13 dBm	§6.6	<-13 dBm	N/A
Frequency Stability	§2.1055 §27.54	<2.5 ppm	§6.4	Within the frequency range	N/A

B12

Uplink: 699-716MHz

Downlink: 729-746MHz

LTE B12					
FCC Part 27 Subpart F					
Industry Canada RSS-130, issue 1, Industry Canada RSS-GEN					
Test item	FCC Reference section	FCC Limit	IC Reference section	IC Limit	Result
RF Output Power	§2.1033 §2.1046 §27.50	<3 Watts ERP	§4.4	<5 Watts E.I.R.P for portable equipment or for indoor fixed subscriber equipment.	Pass
Occupied Bandwidth	§2.1049	N/A	§4.2	N/A	N/A
Peak-to-average power ratio	§27.50	<13 dB	§4.4	<13 dB	N/A
Spurious Emissions	§2.1053 §27.53	<-13 dBm	§4.6	<-13 dBm The e.i.r.p. in the band 1559-1610 MHz shall not exceed -70 dBW/MHz for wideband signal and -80 dBW for discrete emission with bandwidth less than 700 Hz.	Pass
Spurious Emissions at Antenna Terminals	§27.53	<-13 dBm	§4.6	<-13 dBm	N/A
Frequency Stability	§2.1055 §27.54	<±2.5 ppm	§4.3	Within the frequency range	N/A

B14

Uplink: 788-798MHz

Downlink: 758-768MHz

LTE B14					
FCC Part 90 Subpart R					
Industry Canada RSS-140, issue 1, Industry Canada RSS-GEN					
Test item	FCC Reference section	FCC Limit	IC Reference section	IC Limit	Result
RF Output Power	§2.1033 §2.1046 §90.542	<3 Watts ERP	§4.3	<3 Watts ERP	Pass
Occupied Bandwidth	§2.1049	N/A	RSS-GEN §4.2	N/A	N/A
Peak-to-average power ratio	§27.50	<13 dB	§4.3	<13 dB	N/A
Spurious Emissions	§2.1053 §90.543	<-13 dBm	§4.4	<-13 dBm <-70 dBW/MHz e.i.r.p.of all emissions, including harmonics in the band 1559-1610 MHz.	Pass
Spurious Emissions at Antenna Terminals	§90.543	<-35 dBm	§4.4	<-35 dBm for mobile and portable/hand-held equipment	N/A
Frequency Stability	§2.1055 §90.543	<±2.5 ppm	§4.2	Within the frequency range	N/A

B66

Uplink: 1710~1780MHz

Downlink: 2110~2200MHz

LTE B66					
FCC Part 27 Subpart L					
Industry Canada RSS-139, issue 3, Industry Canada RSS-GEN					
Test item	FCC Reference section	FCC Limit	IC Reference section	IC Limit	Result
RF Output Power	§2.1033 §2.1046 §27.50	<1 Watts	§6.5	<1 Watts	Pass
Occupied Bandwidth	§2.1049	N/A	RSS-GEN §4.2	N/A	N/A
Peak-to-average power ratio	§27.50	<13 dB	§6.5	<13 dB	N/A
Spurious Emissions	§2.1053 §27.53	<-13 dBm	§6.6	<-13 dBm	Pass
Spurious Emissions at Antenna Terminals	§27.53	<-13 dBm	§6.6	<-13 dBm	N/A
Frequency Stability	§2.1055 §27.54	<2.5 ppm	§6.4	Within the frequency range	N/A

2.2. Test Environment

Items	Required (IEC 68-1)	Actual	Test Site
Temperature (°C)	15-35	23	2 & 3
Humidity (%RH)	25-75	52	
Barometric pressure (mbar)	860-1060	950-1000	

Note: Test site information refers to Laboratory Information.

Laboratory Information

USA : **FCC Registration Number: TW3024**
Canada : **IC Registration Number: 22397-1 / 22397-2 / 22397-3**

The related certificate for our laboratories about the test site and management system can be downloaded from DEKRA Testing and Certification Co., Ltd. Web Site:

<http://www.dekra.com.tw/english/about/certificates.aspx?bval=5>

The address and introduction of DEKRA Testing and Certification Co., Ltd. laboratories can be founded in our Web site: http://www.dekra.com.tw/index_en.aspx

If you have any comments, Please don't hesitate to contact us. Our test sites as below:

- Site1 No. 75-2, 3rd Lin, WangYe Keng, Yonghxing Tsuen, Qionglin Shiang, Hsinchu County 307, Taiwan (R.O.C.)
 TEL:+886-3-592-8858 / FAX:+886-3-592-8859 E-Mail : info.tw@dekra.com
- Site2 No.372, Sec. 4, Zhongxing Rd., Zhudong Township, Hsinchu County 310, Taiwan, R.O.C.
 TEL: +886-3-582-8001 / FAX: +886-3-582-8958 E-Mail : info.tw@dekra.com
- Site3 No.372-2, Sec. 4, Zhongxing Rd., Zhudong Township, Hsinchu County 310, Taiwan, R.O.C.
 TEL: +886-3-582-8001 / FAX: +886-3-582-8958 E-Mail : info.tw@dekra.com

2.3. List of Test Equipment

RF Output Power / SR10-H

Instrument	Manufacturer	Model No.	Serial No.	Cal. Date	Next Cal. Date
High Speed Peak Power Meter Dual Input	Anritsu	ML2496A	1602004	2018/01/02	2019/01/01
Pulse Power Sensor	Anritsu	MA2411B	1531043	2018/01/02	2019/01/01
Pulse Power Sensor	Anritsu	MA2411B	1531044	2018/01/02	2019/01/01
Power Meter	Keysight	8990B	MY51000248	2018/06/07	2019/06/06
Power Sensor	Keysight	N1923A	MY57240005	2018/06/07	2019/06/06

Conducted Spurious Emissions / SR10-H

Instrument	Manufacturer	Model No.	Serial No.	Cal. Date	Next Cal. Date
Spectrum Analyzer	Keysight	N9030B	MY57140404	2018/06/26	2019/06/25
Spectrum Analyzer	Keysight	N9010B	MY57110159	2018/05/25	2019/05/24
Spectrum Analyzer	Agilent	N9010A	US47140172	2018/07/18	2019/07/17
Signal & Spectrum Analyzer	R&S	FSV40	101049	2018/01/10	2019/01/09

Radiated Spurious Emissions / CB2-H

Instrument	Manufacturer	Model No.	Serial No.	Cal. Date	Next Cal. Date
Horn Antenna	Schwarzbeck	BBHA 9120D	639	2018/06/01	2019/05/31
Bilog Antenna	Teseq	CBL6112D	23191	2018/06/26	2019/06/25
Signal & Spectrum Analyzer	R&S	FSV40	101049	2018/01/10	2019/01/09
EXA Signal Analyzer	Keysight	N9010A	MY51440132	2018/03/05	2019/03/04
Signal Analyzer	R&S	FSVA40	101455	2018/11/05	2019/11/04
Horn Antenna	Schwarzbeck	BBHA 9170	202	2018/01/31	2019/01/30
Pre-Amplifier	Dekra	AP-400C	201801231	2018/12/05	2019/12/04
Pre-Amplifier	EMCI	EMC11830I	980366	2018/01/08	2019/01/07
Horn Antenna	Schwarzbeck	BBHA 9120D	01656	2018/10/17	2019/10/16
Pre-Amplifier	Dekra	AP-025C	201801236	2018/02/26	2019/02/25
Signal Analyzer	R&S	FSV40	101435	2018/07/19	2019/07/18
Wideband Radio Communication Tester	R&S	CMW500	106071	2018/01/29	2019/01/28
Wireless Conn. Tester	R&S	CMW500	157118	2018/08/16	2019/08/15
Coaxial Cable	Suhner	SF104_SF106 - SF104_SF102 (23.5m)	CB4_1	2018/08/21	2019/08/20

Note: All equipment upon which need to calibrated are with calibration period of 1 year.

2.4. Uncertainty

Test Item	Uncertainty
RF Output Power	± 1.27 dB
Spurious Emissions	± 1.27 dB for Conducted Measurement. ± 3.2 dB for Radiated Measurement.

3. RF Output Power

3.1. Test Setup

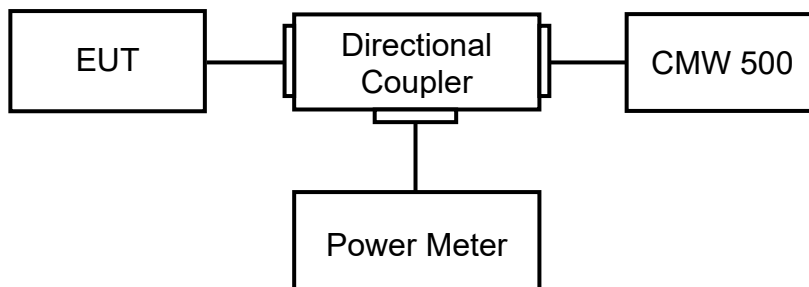

3.2. Test Procedure

- a) The RF output of the transmitter was connected to base station simulator.
- b) The RF output of EUT was connected to the spectrum analyzer by RF cable and attenuator. The path loss was compensated to the results for each measurement..
- c) Set EUT at maximum average power by base station simulator.
- d) Measure lowest, middle, and highest channels for each bandwidth and different modulation.

$$\text{Effective Isotropic Radiated Power} = \text{Conducted Power(dBm)} + \text{Antenna Gain(dBi)}$$

$$\text{Effective Radiated Power} = \text{Conducted Power(dBm)} + \text{Antenna Gain(dBi)} - 2.15\text{dB}$$

3.3. Test Method

KDB 971168 D01 Power Meas License Digital Systems v03 sub-clause 5.2.4
 ANSI C63.26: 2015 Sub-clause 5.2.4.2

3.4. Test Result

Product	LE910C1-SA		
Test Item	RF Output Power		
Test Mode	Mode 1: LTE Band 2		
Date of Test	2018/12/12	Test Site	SR10-H

Band	Channel Freq. (MHz)	Modulation	RB No.	RB offset	MPR	Conducted Output Power (dBm)	RF Output Power (W) EIRP	Limit (W) EIRP		
Band 2 / 1.4MHz	CH 18607 1850.7MHz	QPSK	1	0	0	24.52	0.634	2		
				2		24.39	0.615	2		
				5		24.41	0.618	2		
			3	0	0	23.51	0.502	2		
				1		23.52	0.504	2		
				3		23.65	0.519	2		
			6	0	1	23.49	0.500	2		
			16-QAM	1	1	0	1	23.51	0.502	2
						2		23.48	0.499	2
		5				23.48		0.499	2	
		3		1	0	1	22.24	0.375	2	
					1		22.15	0.367	2	
					3		22.14	0.366	2	
		6	0	2	22.10	0.363	2			

Band	Channel Freq. (MHz)	Modulation	RB No.	RB offset	MPR	Conducted Output Power (dBm)	RF Output Power (W) EIRP	Limit (W) EIRP	
Band 2 / 1.4MHz	CH 18900 1880MHz	QPSK	1	0	0	24.85	0.684	2	
				2		24.82	0.679	2	
				5		24.83	0.681	2	
			3	0	0	23.80	0.537	2	
				1		23.78	0.535	2	
				3		23.79	0.536	2	
			6	0	1	23.78	0.535	2	
			16-QAM	1	1	0	24.19	0.587	2
						2	24.10	0.575	2
		5				24.10	0.575	2	
		3		1	0	22.64	0.411	2	
					1	22.61	0.408	2	
					3	22.56	0.404	2	
		6	0	2	22.48	0.396	2		

Band	Channel Freq. (MHz)	Modulation	RB No.	RB offset	MPR	Conducted Output Power (dBm)	RF Output Power (W) EIRP	Limit (W) EIRP	
Band 2 / 1.4MHz	CH 19193 1909.3MHz	QPSK	1	0	0	24.51	0.632	2	
				2		24.43	0.621	2	
				5		24.40	0.617	2	
			3	0	0	23.58	0.511	2	
				1		23.58	0.511	2	
				3		23.60	0.513	2	
			6	0	1	23.42	0.492	2	
			16-QAM	1	1	0	23.18	0.466	2
						2	23.14	0.461	2
		5				23.06	0.453	2	
		3		1	0	22.65	0.412	2	
					1	22.64	0.411	2	
					3	22.66	0.413	2	
		6		0	2	22.54	0.402	2	

Product	LE910C1-SA		
Test Item	RF Output Power		
Test Mode	Mode 1: LTE Band 2		
Date of Test	2018/12/12	Test Site	SR10-H

Band	Channel Freq. (MHz)	Modulation	RB No.	RB offset	MPR	Conducted Output Power (dBm)	RF Output Power (W) EIRP	Limit (W) EIRP	
Band 2 / 3MHz	CH 18607 1850.7MHz	QPSK	1	0	0	24.40	0.617	2	
				7		24.36	0.611	2	
				14		24.36	0.611	2	
			8	0	1	23.45	0.495	2	
				4		23.42	0.492	2	
				7		23.36	0.485	2	
			15	0	1	23.37	0.486	2	
			16-QAM	1	0	1	23.98	0.560	2
					7		23.95	0.556	2
		14			23.88		0.547	2	
		8		0	2	22.70	0.417	2	
				4		22.68	0.415	2	
				7		22.68	0.415	2	
		15	0	2	22.60	0.407	2		

Band	Channel Freq. (MHz)	Modulation	RB No.	RB offset	MPR	Conducted Output Power (dBm)	RF Output Power (W) EIRP	Limit (W) EIRP	
Band 2 / 3MHz	CH 18900 1880MHz	QPSK	1	0	0	24.52	0.634	2	
				7		24.50	0.631	2	
				14		24.42	0.619	2	
			8	0	1	23.58	0.511	2	
				4		23.55	0.507	2	
				7		23.51	0.502	2	
			15	0	1	23.41	0.491	2	
			16-QAM	1	1	0	23.56	0.508	2
						7	23.42	0.492	2
		14				23.44	0.494	2	
		8		2	0	22.72	0.419	2	
					4	22.56	0.404	2	
					7	22.58	0.406	2	
		15	0	2	22.56	0.404	2		

Band	Channel Freq. (MHz)	Modulation	RB No.	RB offset	MPR	Conducted Output Power (dBm)	RF Output Power (W) EIRP	Limit (W) EIRP	
Band 2 / 3MHz	CH 19193 1909.3MHz	QPSK	1	0	0	24.38	0.614	2	
				7		24.34	0.608	2	
				14		24.32	0.605	2	
			8	0	1	23.36	0.485	2	
				4		23.37	0.486	2	
				7		23.46	0.497	2	
			15	0	1	23.34	0.483	2	
			16-QAM	1	1	0	23.51	0.502	2
						7	23.48	0.499	2
		14				23.40	0.490	2	
		8		2	0	22.47	0.395	2	
					4	22.43	0.392	2	
					7	22.44	0.393	2	
		15	0	2	22.42	0.391	2		

Product	LE910C1-SA		
Test Item	RF Output Power		
Test Mode	Mode 1: LTE Band 2		
Date of Test	2018/12/12	Test Site	SR10-H

Band	Channel Freq. (MHz)	Modulation	RB No.	RB offset	MPR	Conducted Output Power (dBm)	RF Output Power (W) EIRP	Limit (W) EIRP		
Band 2 / 5MHz	CH 18625 1852.5MHz	QPSK	1	0	0	24.35	0.610	2		
				12		24.31	0.604	2		
				24		24.27	0.598	2		
			12	0	1	23.36	0.485	2		
				6		23.40	0.490	2		
				11		23.49	0.500	2		
			25	0	1	23.32	0.481	2		
			16-QAM	1	1	0	1	23.05	0.452	2
						12		22.99	0.446	2
		24				23.01		0.448	2	
		12		2	0	2	22.33	0.383	2	
					6		22.33	0.383	2	
					11		22.36	0.385	2	
		25	0	2	22.22	0.373	2			

Band	Channel Freq. (MHz)	Modulation	RB No.	RB offset	MPR	Conducted Output Power (dBm)	RF Output Power (W) EIRP	Limit (W) EIRP	
Band 2 / 5MHz	CH 18900 1880MHz	QPSK	1	0	0	24.68	0.658	2	
				12		24.65	0.653	2	
				24		24.64	0.652	2	
			12	0	1	23.62	0.515	2	
				6		23.57	0.509	2	
				11		23.57	0.509	2	
			25	0	1	23.57	0.509	2	
			16-QAM	1	0	1	23.16	0.463	2
					12		23.12	0.459	2
		24			23.10		0.457	2	
		12		0	2	22.73	0.420	2	
				6		22.66	0.413	2	
				11		22.63	0.410	2	
		25	0	2	22.60	0.407	2		

Band	Channel Freq. (MHz)	Modulation	RB No.	RB offset	MPR	Conducted Output Power (dBm)	RF Output Power (W) EIRP	Limit (W) EIRP	
Band 2 / 5MHz	CH 19175 1907.5MHz	QPSK	1	0	0	24.36	0.611	2	
				12		24.34	0.608	2	
				24		24.30	0.603	2	
			12	0	1	23.15	0.462	2	
				6		23.17	0.465	2	
				11		23.20	0.468	2	
			25	0	1	23.17	0.465	2	
			16-QAM	1	1	0	23.21	0.469	2
						12	23.16	0.463	2
		24				23.13	0.460	2	
		12		2	0	22.60	0.407	2	
					6	22.55	0.403	2	
					11	22.56	0.404	2	
		25	0	2	22.43	0.392	2		

Product	LE910C1-SA		
Test Item	RF Output Power		
Test Mode	Mode 1: LTE Band 2		
Date of Test	2018/12/12	Test Site	SR10-H

Band	Channel Freq. (MHz)	Modulation	RB No.	RB offset	MPR	Conducted Output Power (dBm)	RF Output Power (W) EIRP	Limit (W) EIRP		
Band 2 / 10MHz	CH 18650 1855MHz	QPSK	1	0	0	24.30	0.603	2		
				24		24.20	0.589	2		
				49		24.21	0.590	2		
			25	0	1	23.28	0.476	2		
				12		23.24	0.472	2		
				24		23.20	0.468	2		
			50	0	1	23.20	0.468	2		
			16-QAM	1	1	0	1	23.60	0.513	2
						24		23.52	0.504	2
		49				23.54		0.506	2	
		27			0	2	22.43	0.392	2	
					12		22.43	0.392	2	
					23		22.61	0.408	2	

Band	Channel Freq. (MHz)	Modulation	RB No.	RB offset	MPR	Conducted Output Power (dBm)	RF Output Power (W) EIRP	Limit (W) EIRP	
Band 2 / 10MHz	CH 18900 1880MHz	QPSK	1	0	0	24.57	0.641	2	
				24		24.51	0.632	2	
				49		24.50	0.631	2	
			25	0	1	23.47	0.498	2	
				12		23.38	0.488	2	
				24		23.37	0.486	2	
			50	0	1	23.37	0.486	2	
			16-QAM	1	1	0	23.58	0.511	2
						24	23.54	0.506	2
		49				23.53	0.505	2	
		27		2	0	22.81	0.428	2	
					12	22.87	0.434	2	
					23	22.95	0.442	2	

Band	Channel Freq. (MHz)	Modulation	RB No.	RB offset	MPR	Conducted Output Power (dBm)	RF Output Power (W) EIRP	Limit (W) EIRP	
Band 2 / 10MHz	CH 19150 1905MHz	QPSK	1	0	0	24.53	0.635	2	
				24		24.49	0.630	2	
				49		24.42	0.619	2	
			25	0	1	23.40	0.490	2	
				12		23.38	0.488	2	
				24		23.49	0.500	2	
			50	0	1	23.36	0.485	2	
			16-QAM	1	1	0	23.37	0.486	2
						24	23.34	0.483	2
		49				23.34	0.483	2	
		27		2	0	22.54	0.402	2	
					12	22.55	0.403	2	
					23	22.65	0.412	2	

Product	LE910C1-SA		
Test Item	RF Output Power		
Test Mode	Mode 1: LTE Band 2		
Date of Test	2018/12/12	Test Site	SR10-H

Band	Channel Freq. (MHz)	Modulation	RB No.	RB offset	MPR	Conducted Output Power (dBm)	RF Output Power (W) EIRP	Limit (W) EIRP	
Band 2 / 15MHz	CH 18675 1857.5MHz	QPSK	1	0	0	24.42	0.619	2	
				37		24.40	0.617	2	
				74		24.39	0.615	2	
			36	0	1	23.50	0.501	2	
				19		23.46	0.497	2	
				38		23.39	0.489	2	
		75	0	1	23.39	0.489	2		
		16-QAM	1	1	0	1	23.73	0.528	2
					37		23.64	0.518	2
					74		23.62	0.515	2
				27	0	2	22.36	0.385	2
					24		22.34	0.384	2
48	22.35				0.385		2		

Band	Channel Freq. (MHz)	Modulation	RB No.	RB offset	MPR	Conducted Output Power (dBm)	RF Output Power (W) EIRP	Limit (W) EIRP	
Band 2 / 15MHz	CH 18900 1880MHz	QPSK	1	0	0	24.69	0.659	2	
				37		24.67	0.656	2	
				74		24.67	0.656	2	
			36	0	1	23.67	0.521	2	
				19		23.63	0.516	2	
				38		23.61	0.514	2	
			75	0	1	23.55	0.507	2	
			16-QAM	1	1	0	23.68	0.522	2
						37	23.63	0.516	2
		74				23.62	0.515	2	
		27		2	0	22.77	0.424	2	
					24	22.81	0.428	2	
					48	22.86	0.433	2	

Band	Channel Freq. (MHz)	Modulation	RB No.	RB offset	MPR	Conducted Output Power (dBm)	RF Output Power (W) EIRP	Limit (W) EIRP	
Band 2 / 15MHz	CH 19125 1902.5MHz	QPSK	1	0	0	24.74	0.667	2	
				37		24.69	0.659	2	
				74		24.67	0.656	2	
			36	0	1	23.81	0.538	2	
				19		23.81	0.538	2	
				38		23.83	0.541	2	
			75	0	1	23.70	0.525	2	
			16-QAM	1	1	0	23.18	0.466	2
						37	23.12	0.459	2
		74				23.10	0.457	2	
		27		2	0	22.53	0.401	2	
					24	22.51	0.399	2	
					48	22.52	0.400	2	

Product	LE910C1-SA		
Test Item	RF Output Power		
Test Mode	Mode 1: LTE Band 2		
Date of Test	2018/12/12	Test Site	SR10-H

Band	Channel Freq. (MHz)	Modulation	RB No.	RB offset	MPR	Conducted Output Power (dBm)	RF Output Power (W) EIRP	Limit (W) EIRP		
Band 2 / 20MHz	CH 18700 1860MHz	QPSK	1	0	0	24.21	0.590	2		
				49		24.17	0.585	2		
				99		24.11	0.577	2		
			50	0	1	23.08	0.455	2		
				25		23.09	0.456	2		
				49		23.26	0.474	2		
			100	0	1	23.09	0.456	2		
			16-QAM	1	1	0	1	23.93	0.553	2
						49		23.88	0.547	2
		99				23.87		0.546	2	
		27		2	0	2	22.27	0.378	2	
					36		22.26	0.377	2	
					73		22.28	0.378	2	

Band	Channel Freq. (MHz)	Modulation	RB No.	RB offset	MPR	Conducted Output Power (dBm)	RF Output Power (W) EIRP	Limit (W) EIRP	
Band 2 / 20MHz	CH 18900 1880MHz	QPSK	1	0	0	24.60	0.646	2	
				49		24.53	0.635	2	
				99		24.49	0.630	2	
			50	0	1	23.55	0.507	2	
				25		23.52	0.504	2	
				49		23.52	0.504	2	
			100	0	1	23.49	0.500	2	
			16-QAM	1	1	0	24.24	0.594	2
						49	24.21	0.590	2
		99				24.20	0.589	2	
		27		2	0	22.52	0.400	2	
					36	22.61	0.408	2	
					73	22.68	0.415	2	

Band	Channel Freq. (MHz)	Modulation	RB No.	RB offset	MPR	Conducted Output Power (dBm)	RF Output Power (W) EIRP	Limit (W) EIRP	
Band 2 / 20MHz	CH 19100 1900MHz	QPSK	1	0	0	24.69	0.659	2	
				49		24.58	0.643	2	
				99		24.57	0.641	2	
			50	0	1	23.59	0.512	2	
				25		23.63	0.516	2	
				49		23.66	0.520	2	
			100	0	1	23.56	0.508	2	
			16-QAM	1	1	0	24.19	0.587	2
						49	24.11	0.577	2
		99				24.07	0.571	2	
		27		2	0	22.55	0.403	2	
					36	22.54	0.402	2	
					73	22.59	0.406	2	

Product	LE910C1-SA		
Test Item	RF Output Power		
Test Mode	Mode 2: LTE Band 4		
Date of Test	2018/12/12	Test Site	SR10-H

Band	Channel Freq. (MHz)	Modulation	RB No.	RB offset	MPR	Conducted Output Power (dBm)	RF Output Power (W) EIRP	Limit (W) EIRP	
Band 4 / 1.4MHz	CH 19957 1710.7MHz	QPSK	1	0	0	23.35	0.484	1	
				2		23.28	0.476	1	
				5		23.26	0.474	1	
			3	0	0	22.28	0.378	1	
				1		22.27	0.378	1	
				3		22.30	0.380	1	
		6	0	1	22.16	0.368	1		
		16-QAM	1	1	0	1	22.53	0.401	1
					2		22.50	0.398	1
					5		22.46	0.394	1
			3	1	0	1	21.70	0.331	1
					1		21.63	0.326	1
					3		21.63	0.326	1
			6	0	2	21.60	0.324	1	

Band	Channel Freq. (MHz)	Modulation	RB No.	RB offset	MPR	Conducted Output Power (dBm)	RF Output Power (W) EIRP	Limit (W) EIRP	
Band 4 / 1.4MHz	CH 20175 1732.5MHz	QPSK	1	0	0	23.40	0.490	1	
				2		23.33	0.482	1	
				5		23.29	0.478	1	
			3	0	0	22.36	0.385	1	
				1		22.36	0.385	1	
				3		22.39	0.388	1	
			6	0	1	22.30	0.380	1	
			16-QAM	1	1	0	22.57	0.405	1
						2	22.50	0.398	1
		5				22.45	0.394	1	
		3		1	0	21.70	0.331	1	
					1	21.68	0.330	1	
					3	21.67	0.329	1	
		6	0	2	21.61	0.324	1		

Band	Channel Freq. (MHz)	Modulation	RB No.	RB offset	MPR	Conducted Output Power (dBm)	RF Output Power (W) EIRP	Limit (W) EIRP	
Band 4 / 1.4MHz	CH 20393 1754.3MHz	QPSK	1	0	0	23.67	0.521	1	
				2		23.64	0.518	1	
				5		23.64	0.518	1	
			3	0	0	22.66	0.413	1	
				1		22.66	0.413	1	
				3		22.82	0.429	1	
		6	0	1	22.65	0.412	1		
		16-QAM	1	1	0	1	23.03	0.450	1
					2		23.00	0.447	1
					5		22.99	0.446	1
			3	1	0	1	21.65	0.327	1
					1		21.63	0.326	1
					3		21.66	0.328	1
			6	0	2	21.51	0.317	1	

Product	LE910C1-SA		
Test Item	RF Output Power		
Test Mode	Mode 2: LTE Band 4		
Date of Test	2018/12/12	Test Site	SR10-H

Band	Channel Freq. (MHz)	Modulation	RB No.	RB offset	MPR	Conducted Output Power (dBm)	RF Output Power (W) EIRP	Limit (W) EIRP	
Band 4 / 3MHz	CH 19965 1711.5MHz	QPSK	1	0	0	23.39	0.489	1	
				7		23.33	0.482	1	
				14		23.28	0.476	1	
			8	0	1	22.34	0.384	1	
				4		22.34	0.384	1	
				7		22.37	0.386	1	
		15	0	1	22.22	0.373	1		
		16-QAM	1	1	0	1	22.56	0.404	1
					7		22.53	0.401	1
					14		22.47	0.395	1
			8	2	0	2	21.43	0.311	1
					4		21.41	0.310	1
					7		21.41	0.310	1
		15	0	2	21.43	0.311	1		

Band	Channel Freq. (MHz)	Modulation	RB No.	RB offset	MPR	Conducted Output Power (dBm)	RF Output Power (W) EIRP	Limit (W) EIRP	
Band 4 / 3MHz	CH 20175 1732.5MHz	QPSK	1	0	0	23.31	0.480	1	
				7		23.28	0.476	1	
				14		23.27	0.475	1	
			8	0	1	22.28	0.378	1	
				4		22.26	0.377	1	
				7		22.25	0.376	1	
			15	0	1	22.18	0.370	1	
			16-QAM	1	1	0	22.81	0.428	1
						7	22.74	0.421	1
		14				22.75	0.422	1	
		8		2	0	21.52	0.318	1	
					4	21.64	0.327	1	
					7	21.66	0.328	1	
		15	0	2	21.49	0.316	1		

Band	Channel Freq. (MHz)	Modulation	RB No.	RB offset	MPR	Conducted Output Power (dBm)	RF Output Power (W) EIRP	Limit (W) EIRP	
Band 4 / 3MHz	CH 20385 1753.5MHz	QPSK	1	0	0	23.68	0.522	1	
				7		23.61	0.514	1	
				14		23.61	0.514	1	
			8	0	1	22.81	0.428	1	
				4		22.75	0.422	1	
				7		22.64	0.411	1	
			15	0	1	22.65	0.412	1	
			16-QAM	1	1	0	23.10	0.457	1
						7	23.06	0.453	1
		14				23.02	0.449	1	
		8		2	0	21.72	0.333	1	
					4	21.73	0.333	1	
					7	21.75	0.335	1	
		15	0	2	21.73	0.333	1		

Product	LE910C1-SA		
Test Item	RF Output Power		
Test Mode	Mode 2: LTE Band 4		
Date of Test	2018/12/12	Test Site	SR10-H

Band	Channel Freq. (MHz)	Modulation	RB No.	RB offset	MPR	Conducted Output Power (dBm)	RF Output Power (W) EIRP	Limit (W) EIRP	
Band 4 / 5MHz	CH 19975 1712.5MHz	QPSK	1	0	0	23.27	0.475	1	
				12		23.23	0.471	1	
				24		23.24	0.472	1	
			12	0	1	22.44	0.393	1	
				6		22.41	0.390	1	
				11		22.43	0.392	1	
		25	0	1	22.26	0.377	1		
		16-QAM	1	1	0	1	22.83	0.430	1
					12		22.78	0.425	1
					24		22.78	0.425	1
			12	2	0	2	21.65	0.327	1
					6		21.62	0.325	1
					11		21.64	0.327	1
		25	0	2	21.51	0.317	1		

Band	Channel Freq. (MHz)	Modulation	RB No.	RB offset	MPR	Conducted Output Power (dBm)	RF Output Power (W) EIRP	Limit (W) EIRP	
Band 4 / 5MHz	CH 20175 1732.5MHz	QPSK	1	0	0	23.41	0.491	1	
				12		23.37	0.486	1	
				24		23.34	0.483	1	
			12	0	1	22.46	0.394	1	
				6		22.33	0.383	1	
				11		22.30	0.380	1	
			25	0	1	22.30	0.380	1	
			16-QAM	1	1	0	22.12	0.365	1
						12	22.06	0.360	1
		24				22.07	0.361	1	
		12		2	0	21.52	0.318	1	
					6	21.49	0.316	1	
					11	21.51	0.317	1	
		25	0	2	21.47	0.314	1		

Band	Channel Freq. (MHz)	Modulation	RB No.	RB offset	MPR	Conducted Output Power (dBm)	RF Output Power (W) EIRP	Limit (W) EIRP	
Band 4 / 5MHz	CH 20375 1752.5MHz	QPSK	1	0	0	23.71	0.526	1	
				12		23.68	0.522	1	
				24		23.68	0.522	1	
			12	0	1	22.73	0.420	1	
				6		22.66	0.413	1	
				11		22.63	0.410	1	
			25	0	1	22.62	0.409	1	
			16-QAM	1	1	0	22.56	0.404	1
						12	22.50	0.398	1
		24				22.50	0.398	1	
		12		2	0	22.02	0.356	1	
					6	22.00	0.355	1	
					11	22.02	0.356	1	
		25	0	2	21.89	0.346	1		

Product	LE910C1-SA		
Test Item	RF Output Power		
Test Mode	Mode 2: LTE Band 4		
Date of Test	2018/12/12	Test Site	SR10-H

Band	Channel Freq. (MHz)	Modulation	RB No.	RB offset	MPR	Conducted Output Power (dBm)	RF Output Power (W) EIRP	Limit (W) EIRP		
Band 4 / 10MHz	CH 20000 1715MHz	QPSK	1	0	0	23.43	0.493	1		
				24		23.38	0.488	1		
				49		23.33	0.482	1		
			25	0	1	22.40	0.389	1		
				12		22.40	0.389	1		
				24		22.44	0.393	1		
			50	0	1	22.36	0.385	1		
			16-QAM	1	1	0	1	22.37	0.386	1
						24		22.35	0.385	1
		49				22.33		0.383	1	
		27			0	2	21.48	0.315	1	
					12		21.33	0.304	1	
					23		21.34	0.305	1	

Band	Channel Freq. (MHz)	Modulation	RB No.	RB offset	MPR	Conducted Output Power (dBm)	RF Output Power (W) EIRP	Limit (W) EIRP	
Band 4 / 10MHz	CH 20175 1732.5MHz	QPSK	1	0	0	23.36	0.485	1	
				24		23.30	0.479	1	
				49		23.32	0.481	1	
			25	0	1	22.17	0.369	1	
				12		22.25	0.376	1	
				24		22.35	0.385	1	
			50	0	1	22.19	0.371	1	
			16-QAM	1	1	0	22.35	0.385	1
						24	22.33	0.383	1
		49				22.27	0.378	1	
		27		2	0	21.57	0.321	1	
					12	21.50	0.316	1	
					23	21.51	0.317	1	

Band	Channel Freq. (MHz)	Modulation	RB No.	RB offset	MPR	Conducted Output Power (dBm)	RF Output Power (W) EIRP	Limit (W) EIRP	
Band 4 / 10MHz	CH 20350 1750MHz	QPSK	1	0	0	23.64	0.518	1	
				24		23.59	0.512	1	
				49		23.59	0.512	1	
			25	0	1	22.66	0.413	1	
				12		22.64	0.411	1	
				24		22.66	0.413	1	
			50	0	1	22.59	0.406	1	
			16-QAM	1	1	0	23.08	0.455	1
						24	23.04	0.451	1
		49				23.05	0.452	1	
		27		2	0	21.74	0.334	1	
					12	21.75	0.335	1	
					23	21.80	0.339	1	

Product	LE910C1-SA		
Test Item	RF Output Power		
Test Mode	Mode 2: LTE Band 4		
Date of Test	2018/12/12	Test Site	SR10-H

Band	Channel Freq. (MHz)	Modulation	RB No.	RB offset	MPR	Conducted Output Power (dBm)	RF Output Power (W) EIRP	Limit (W) EIRP		
Band 4 / 15MHz	CH 20025 1717.5MHz	QPSK	1	0	0	23.31	0.480	1		
				37		23.24	0.472	1		
				74		23.22	0.470	1		
			36	0	1	22.15	0.367	1		
				19		22.20	0.372	1		
				38		22.22	0.373	1		
			75	0	1	22.13	0.366	1		
			16-QAM	1	1	0	1	22.22	0.373	1
						37		22.12	0.365	1
		74				22.12		0.365	1	
		27			0	2	21.40	0.309	1	
					24		21.34	0.305	1	
					48		21.35	0.305	1	

Band	Channel Freq. (MHz)	Modulation	RB No.	RB offset	MPR	Conducted Output Power (dBm)	RF Output Power (W) EIRP	Limit (W) EIRP	
Band 4 / 15MHz	CH 20175 1732.5MHz	QPSK	1	0	0	23.27	0.475	1	
				37		23.22	0.470	1	
				74		23.20	0.468	1	
			36	0	1	22.30	0.380	1	
				19		22.27	0.378	1	
				38		22.16	0.368	1	
			75	0	1	22.15	0.367	1	
			16-QAM	1	1	0	22.34	0.384	1
						37	22.31	0.381	1
		74				22.31	0.381	1	
		27		2	0	21.48	0.315	1	
					24	21.40	0.309	1	
					48	21.40	0.309	1	

Band	Channel Freq. (MHz)	Modulation	RB No.	RB offset	MPR	Conducted Output Power (dBm)	RF Output Power (W) EIRP	Limit (W) EIRP	
Band 4 / 15MHz	CH 20325 1747.5MHz	QPSK	1	0	0	23.63	0.516	1	
				37		23.58	0.511	1	
				74		23.56	0.508	1	
			36	0	1	22.75	0.422	1	
				19		22.65	0.412	1	
				38		22.64	0.411	1	
			75	0	1	22.58	0.406	1	
			16-QAM	1	1	0	23.33	0.482	1
						37	23.22	0.470	1
		74				23.22	0.470	1	
		27		2	0	21.85	0.343	1	
					24	21.73	0.333	1	
					48	21.67	0.329	1	

Product	LE910C1-SA		
Test Item	RF Output Power		
Test Mode	Mode 2: LTE Band 4		
Date of Test	2018/12/12	Test Site	SR10-H

Band	Channel Freq. (MHz)	Modulation	RB No.	RB offset	MPR	Conducted Output Power (dBm)	RF Output Power (W) EIRP	Limit (W) EIRP		
Band 4 / 20MHz	CH 20050 1720MHz	QPSK	1	0	0	23.37	0.486	1		
				49		23.29	0.478	1		
				99		23.27	0.475	1		
			50	0	1	22.37	0.386	1		
				25		22.35	0.385	1		
				49		22.39	0.388	1		
			100	0	1	22.34	0.384	1		
			16-QAM	1	1	0	1	22.59	0.406	1
						49		22.55	0.403	1
		99				22.52		0.400	1	
		27		2	0	2	21.45	0.313	1	
					36		21.42	0.310	1	
					73		21.42	0.310	1	

Band	Channel Freq. (MHz)	Modulation	RB No.	RB offset	MPR	Conducted Output Power (dBm)	RF Output Power (W) EIRP	Limit (W) EIRP	
Band 4 / 20MHz	CH 20175 1732.5MHz	QPSK	1	0	0	23.13	0.460	1	
				49		23.04	0.451	1	
				99		23.03	0.450	1	
			50	0	1	22.19	0.371	1	
				25		22.21	0.372	1	
				49		22.25	0.376	1	
			100	0	1	22.12	0.365	1	
			16-QAM	1	1	0	22.71	0.418	1
						49	22.64	0.411	1
		99				22.66	0.413	1	
		27		2	0	21.59	0.323	1	
					36	21.55	0.320	1	
					73	21.56	0.321	1	

Band	Channel Freq. (MHz)	Modulation	RB No.	RB offset	MPR	Conducted Output Power (dBm)	RF Output Power (W) EIRP	Limit (W) EIRP	
Band 4 / 20MHz	CH 20300 1745MHz	QPSK	1	0	0	23.66	0.520	1	
				49		23.63	0.516	1	
				99		23.64	0.518	1	
			50	0	1	22.49	0.397	1	
				25		22.52	0.400	1	
				49		22.54	0.402	1	
			100	0	1	22.48	0.396	1	
			16-QAM	1	1	0	23.18	0.466	1
						49	23.15	0.462	1
		99				23.15	0.462	1	
		27		2	0	21.66	0.328	1	
					36	21.64	0.327	1	
					73	21.66	0.328	1	

Product	LE910C1-SA		
Test Item	RF Output Power		
Test Mode	Mode 3: LTE Band 12		
Date of Test	2018/12/12	Test Site	SR10-H

Band	Channel Freq. (MHz)	Modulation	RB No.	RB offset	MPR	Conducted Output Power (dBm)	RF Output Power (W) ERP	FCC Limit (W) ERP	IC Limit (W) EIRP	
Band 12 / 1.4MHz	CH 23017 699.7MHz	QPSK	1	0	0	24.98	0.383	3	5	
				2		24.95	0.380	3	5	
				5		24.93	0.378	3	5	
			3	0	0	24.01	0.306	3	5	
				1		23.97	0.303	3	5	
				3		23.98	0.304	3	5	
			6	0	1	23.88	0.297	3	5	
			16-QAM	1	0	1	23.80	0.292	3	5
					2		23.70	0.285	3	5
		5			23.72		0.286	3	5	
		3		0	1	22.79	0.231	3	5	
				1		22.78	0.231	3	5	
				3		22.83	0.233	3	5	
		6		0	2	22.65	0.224	3	5	

Band	Channel Freq. (MHz)	Modulation	RB No.	RB offset	MPR	Conducted Output Power (dBm)	RF Output Power (W) ERP	FCC Limit (W) ERP	IC Limit (W) EIRP	
Band 12 / 1.4MHz	CH 23097 707.5MHz	QPSK	1	0	0	24.16	0.317	3	5	
				2		24.10	0.313	3	5	
				5		24.06	0.310	3	5	
			3	0	0	23.15	0.251	3	5	
				1		23.14	0.251	3	5	
				3		23.17	0.252	3	5	
		6	0	1	23.13	0.250	3	5		
		16-QAM	1	1	0	1	22.92	0.238	3	5
					2		22.87	0.236	3	5
					5		22.87	0.236	3	5
			3	1	0	1	21.89	0.188	3	5
					1		21.87	0.187	3	5
					3		21.87	0.187	3	5
			6	0	2	21.80	0.184	3	5	

Band	Channel Freq. (MHz)	Modulation	RB No.	RB offset	MPR	Conducted Output Power (dBm)	RF Output Power (W) ERP	FCC Limit (W) ERP	IC Limit (W) EIRP		
Band 12 / 1.4MHz	CH 23173 715.3MHz	QPSK	1	0	0	24.67	0.356	3	5		
				2		24.63	0.353	3	5		
				5		24.62	0.352	3	5		
			3	0	0	23.52	0.274	3	5		
				1		23.52	0.274	3	5		
				3		23.56	0.276	3	5		
			6	0	1	23.49	0.272	3	5		
			16-QAM	1	1	0	1	23.56	0.276	3	5
						2		23.47	0.270	3	5
		5				23.48		0.271	3	5	
		3		1	0	1	22.33	0.208	3	5	
					1		22.40	0.211	3	5	
					3		22.50	0.216	3	5	
		6	0	2	22.35	0.209	3	5			

Product	LE910C1-SA		
Test Item	RF Output Power		
Test Mode	Mode 3: LTE Band 12		
Date of Test	2018/12/12	Test Site	SR10-H

Band	Channel Freq. (MHz)	Modulation	RB No.	RB offset	MPR	Conducted Output Power (dBm)	RF Output Power (W) ERP	FCC Limit (W) ERP	IC Limit (W) EIRP	
Band 12 / 3MHz	CH 23025 700.5MHz	QPSK	1	0	0	24.82	0.369	3	5	
				7		24.79	0.366	3	5	
				14		24.78	0.366	3	5	
			8	0	1	23.84	0.294	3	5	
				4		23.80	0.292	3	5	
				7		23.82	0.293	3	5	
		15	0	1	23.66	0.282	3	5		
		16-QAM	1	1	0	1	23.70	0.285	3	5
					7		23.58	0.277	3	5
					14		23.59	0.278	3	5
			8	2	0	2	22.78	0.231	3	5
					4		22.78	0.231	3	5
					7		22.83	0.233	3	5
		15	0	2	22.68	0.225	3	5		

Band	Channel Freq. (MHz)	Modulation	RB No.	RB offset	MPR	Conducted Output Power (dBm)	RF Output Power (W) ERP	FCC Limit (W) ERP	IC Limit (W) EIRP
Band 12 / 3MHz	CH 23095 707.5MHz	QPSK	1	0	0	24.10	0.313	3	5
				7		24.03	0.308	3	5
				14		24.03	0.308	3	5
			8	0	1	23.02	0.244	3	5
				4		23.00	0.243	3	5
				7		23.01	0.243	3	5
		15	0	1	22.92	0.238	3	5	
		16-QAM	1	1	0	22.84	0.234	3	5
					7	22.77	0.230	3	5
					14	22.76	0.230	3	5
			8	2	0	21.89	0.188	3	5
					4	21.87	0.187	3	5
					7	21.90	0.188	3	5
			15	0	2	21.77	0.183	3	5

Band	Channel Freq. (MHz)	Modulation	RB No.	RB offset	MPR	Conducted Output Power (dBm)	RF Output Power (W) ERP	FCC Limit (W) ERP	IC Limit (W) EIRP	
Band 12 / 3MHz	CH 23165 714.5MHz	QPSK	1	0	0	24.02	0.307	3	5	
				7		23.96	0.303	3	5	
				14		23.94	0.301	3	5	
			8	0	1	23.00	0.243	3	5	
				4		23.09	0.248	3	5	
				7		23.12	0.249	3	5	
			15	0	1	22.99	0.242	3	5	
			16-QAM	1	1	0	22.74	0.229	3	5
						7	22.70	0.226	3	5
		14				22.70	0.226	3	5	
		8		2	0	21.59	0.175	3	5	
					4	21.70	0.180	3	5	
					7	21.72	0.181	3	5	
		15	0	2	21.58	0.175	3	5		

Product	LE910C1-SA		
Test Item	RF Output Power		
Test Mode	Mode 3: LTE Band 12		
Date of Test	2018/12/12	Test Site	SR10-H

Band	Channel Freq. (MHz)	Modulation	RB No.	RB offset	MPR	Conducted Output Power (dBm)	RF Output Power (W) ERP	FCC Limit (W) ERP	IC Limit (W) EIRP		
Band 12 / 5MHz	CH 23035 701.5MHz	QPSK	1	0	0	24.95	0.380	3	5		
				12		24.91	0.377	3	5		
				24		24.83	0.370	3	5		
			12	0	1	23.91	0.299	3	5		
				6		23.89	0.298	3	5		
				11		23.94	0.301	3	5		
			25	0	1	23.78	0.290	3	5		
			16-QAM	1	1	0	1	23.72	0.286	3	5
						12		23.69	0.284	3	5
		24				23.68		0.284	3	5	
		12			0	2	22.74	0.229	3	5	
					6		22.72	0.228	3	5	
					11		22.76	0.230	3	5	
		25	0	2	22.68	0.225	3	5			

Band	Channel Freq. (MHz)	Modulation	RB No.	RB offset	MPR	Conducted Output Power (dBm)	RF Output Power (W) ERP	FCC Limit (W) ERP	IC Limit (W) EIRP	
Band 12 / 5MHz	CH 23095 707.5MHz	QPSK	1	0	0	24.07	0.310	3	5	
				12		24.02	0.307	3	5	
				24		24.03	0.308	3	5	
			12	0	1	22.98	0.242	3	5	
				6		23.01	0.243	3	5	
				11		23.07	0.247	3	5	
			25	0	1	22.93	0.239	3	5	
			16-QAM	1	1	0	22.77	0.230	3	5
						12	22.70	0.226	3	5
		24				22.72	0.228	3	5	
		12		2	0	21.65	0.178	3	5	
					6	21.63	0.177	3	5	
					11	21.65	0.178	3	5	
		25	0	2	21.61	0.176	3	5		

Band	Channel Freq. (MHz)	Modulation	RB No.	RB offset	MPR	Conducted Output Power (dBm)	RF Output Power (W) ERP	FCC Limit (W) ERP	IC Limit (W) EIRP	
Band 12 / 5MHz	CH 23155 713.5MHz	QPSK	1	0	0	23.99	0.305	3	5	
				12		23.90	0.299	3	5	
				24		23.87	0.296	3	5	
			12	0	1	22.81	0.232	3	5	
				6		22.80	0.232	3	5	
				11		22.83	0.233	3	5	
			25	0	1	22.79	0.231	3	5	
			16-QAM	1	1	0	22.70	0.226	3	5
						12	22.67	0.225	3	5
		24				22.60	0.221	3	5	
		12		2	0	21.64	0.177	3	5	
					6	21.65	0.178	3	5	
					11	21.67	0.179	3	5	
		25	0	2	21.58	0.175	3	5		

Product	LE910C1-SA		
Test Item	RF Output Power		
Test Mode	Mode 3: LTE Band 12		
Date of Test	2018/12/12	Test Site	SR10-H

Band	Channel Freq. (MHz)	Modulation	RB No.	RB offset	MPR	Conducted Output Power (dBm)	RF Output Power (W) ERP	FCC Limit (W) ERP	IC Limit (W) EIRP		
Band 12 / 10MHz	CH 23060 704MHz	QPSK	1	0	0	24.59	0.350	3	5		
				24		24.52	0.344	3	5		
				49		24.48	0.341	3	5		
			25	0	1	23.49	0.272	3	5		
				12		23.45	0.269	3	5		
				24		23.40	0.266	3	5		
			50	0	1	23.34	0.262	3	5		
			16-QAM	1	1	0	1	24.05	0.309	3	5
						24		23.99	0.305	3	5
		49				23.98		0.304	3	5	
		27			0	2	22.61	0.222	3	5	
					12		22.59	0.221	3	5	
					23		22.63	0.223	3	5	

Band	Channel Freq. (MHz)	Modulation	RB No.	RB offset	MPR	Conducted Output Power (dBm)	RF Output Power (W) ERP	FCC Limit (W) ERP	IC Limit (W) EIRP	
Band 12 / 10MHz	CH 23095 707.5MHz	QPSK	1	0	0	24.29	0.327	3	5	
				24		24.17	0.318	3	5	
				49		24.17	0.318	3	5	
			25	0	1	22.86	0.235	3	5	
				12		22.86	0.235	3	5	
				24		22.91	0.238	3	5	
			50	0	1	22.81	0.232	3	5	
			16-QAM	1	1	0	23.54	0.275	3	5
						24	23.51	0.273	3	5
		49				23.46	0.270	3	5	
		27		2	0	22.13	0.199	3	5	
					12	22.14	0.199	3	5	
					23	22.23	0.203	3	5	

Band	Channel Freq. (MHz)	Modulation	RB No.	RB offset	MPR	Conducted Output Power (dBm)	RF Output Power (W) ERP	FCC Limit (W) ERP	IC Limit (W) EIRP	
Band 12 / 10MHz	CH 23130 711MHz	QPSK	1	0	0	24.03	0.308	3	5	
				24		23.94	0.301	3	5	
				49		23.96	0.303	3	5	
			25	0	1	23.12	0.249	3	5	
				12		23.08	0.247	3	5	
				24		23.00	0.243	3	5	
			50	0	1	23.01	0.243	3	5	
			16-QAM	1	1	0	23.31	0.261	3	5
						24	23.28	0.259	3	5
		49				23.23	0.256	3	5	
		27		2	0	22.08	0.196	3	5	
					12	22.14	0.199	3	5	
					23	22.17	0.200	3	5	

Product	LE910C1-SA		
Test Item	RF Output Power		
Test Mode	Mode 4: LTE Band 14		
Date of Test	2018/12/12	Test Site	SR10-H

Band	Channel Freq. (MHz)	Modulation	RB No.	RB offset	MPR	Conducted Output Power (dBm)	RF Output Power (W) ERP	Limit (W) ERP		
Band 14 / 5MHz	CH 23305 790.5MHz	QPSK	1	0	0	24.51	0.344	3		
				12		24.37	0.333	3		
				24		24.39	0.334	3		
			12	0	1	23.74	0.288	3		
				6		23.65	0.282	3		
				11		23.61	0.279	3		
			25	0	1	23.59	0.278	3		
			16-QAM	1	1	0	1	23.24	0.256	3
						12		23.15	0.251	3
		24				23.16		0.252	3	
		12			0	2	22.86	0.235	3	
					6		22.8	0.232	3	
					11		22.8	0.232	3	
		25	0	2	22.72	0.228	3			

Band	Channel Freq. (MHz)	Modulation	RB No.	RB offset	MPR	Conducted Output Power (dBm)	RF Output Power (W) ERP	Limit (W) ERP	
Band 14 / 5MHz	CH 23330 793MHz	QPSK	1	0	0	24.52	0.344	3	
				12		24.49	0.342	3	
				24		24.45	0.339	3	
			12	0	1	23.66	0.282	3	
				6		23.66	0.282	3	
				11		23.73	0.287	3	
			25	0	1	23.57	0.277	3	
			16-QAM	1	1	0	23.43	0.268	3
						12	23.36	0.264	3
		24				23.35	0.263	3	
		12		2	0	22.61	0.222	3	
					6	22.56	0.219	3	
					11	22.53	0.218	3	
		25	0	2	22.43	0.213	3		

Band	Channel Freq. (MHz)	Modulation	RB No.	RB offset	MPR	Conducted Output Power (dBm)	RF Output Power (W) ERP	Limit (W) ERP	
Band 14 / 5MHz	CH 23355 795.5MHz	QPSK	1	0	0	24.33	0.330	3	
				12		24.31	0.328	3	
				24		24.31	0.328	3	
			12	0	1	23.79	0.291	3	
				6		23.73	0.287	3	
				11		23.62	0.280	3	
			25	0	1	23.61	0.279	3	
			16-QAM	1	1	0	22.95	0.240	3
						12	22.91	0.238	3
		24				22.88	0.236	3	
		12		2	0	22.61	0.222	3	
					6	22.56	0.219	3	
					11	22.56	0.219	3	
		25	0	2	22.54	0.218	3		

Product	LE910C1-SA		
Test Item	RF Output Power		
Test Mode	Mode 4: LTE Band 14		
Date of Test	2018/12/12	Test Site	SR10-H

Band	Channel Freq. (MHz)	Modulation	RB No.	RB offset	MPR	Conducted Output Power (dBm)	RF Output Power (W) ERP	Limit (W) ERP		
Band 14 / 10MHz	CH 23330 793MHz	QPSK	1	0	0	24.42	0.337	3		
				24		24.3	0.327	3		
				49		24.31	0.328	3		
			25	0	1	23.63	0.281	3		
				12		23.63	0.281	3		
				24		23.68	0.284	3		
			50	0	1	23.52	0.274	3		
			16-QAM	1	1	0	1	23.2	0.254	3
						24		23.18	0.253	3
		49				23.13		0.250	3	
		27			0	2	22.72	0.228	3	
					12		22.74	0.229	3	
					23		22.81	0.232	3	

Product	LE910C1-SA		
Test Item	RF Output Power		
Test Mode	Mode 5: LTE Band 66		
Date of Test	2018/12/12	Test Site	SR10-H

Band	Channel Freq. (MHz)	Modulation	RB No.	RB offset	MPR	Conducted Output Power (dBm)	RF Output Power (W) EIRP	Limit (W) EIRP		
Band 66 / 1.4MHz	CH 131979 1710.7MHz	QPSK	1	0	0	23.09	0.456	1		
				2		23.04	0.451	1		
				5		23.02	0.449	1		
			3	0	0	22.13	0.366	1		
				1		22.09	0.362	1		
				3		22.08	0.361	1		
			6	0	1	22.05	0.359	1		
			16-QAM	1	1	0	1	22.00	0.355	1
						2		21.91	0.348	1
		5				21.89		0.346	1	
		3			0	1	21.28	0.301	1	
					1		21.19	0.294	1	
					3		21.21	0.296	1	
		6	0	2	21.22	0.296	1			

Band	Channel Freq. (MHz)	Modulation	RB No.	RB offset	MPR	Conducted Output Power (dBm)	RF Output Power (W) EIRP	Limit (W) EIRP	
Band 66 / 1.4MHz	CH 132322 1745MHz	QPSK	1	0	0	23.87	0.546	1	
				2		23.74	0.530	1	
				5		23.75	0.531	1	
			3	0	0	22.03	0.357	1	
				1		22.03	0.357	1	
				3		22.11	0.364	1	
			6	0	1	22.00	0.355	1	
			16-QAM	1	1	0	22.86	0.433	1
						2	22.77	0.424	1
		5				22.76	0.423	1	
		3		1	0	21.87	0.344	1	
					1	21.86	0.344	1	
					3	21.89	0.346	1	
		6	0	2	21.83	0.341	1		

Band	Channel Freq. (MHz)	Modulation	RB No.	RB offset	MPR	Conducted Output Power (dBm)	RF Output Power (W) EIRP	Limit (W) EIRP
Band 66 / 1.4MHz	CH 132665 / 1779.3MHz	QPSK	1	0	0	23.93	0.553	1
				2		23.90	0.550	1
				5		23.91	0.551	1
			3	0	0	23.13	0.460	1
				1		23.03	0.450	1
				3		23.03	0.450	1
		6	0	1	22.96	0.443	1	
		16-QAM	1	1	0	23.23	0.471	1
					2	23.10	0.457	1
					5	23.12	0.459	1
			3	1	0	22.03	0.357	1
					1	21.97	0.352	1
					3	21.96	0.352	1
			6	0	2	21.93	0.349	1

Product	LE910C1-SA		
Test Item	RF Output Power		
Test Mode	Mode 5: LTE Band 66		
Date of Test	2018/12/12	Test Site	SR10-H

Band	Channel Freq. (MHz)	Modulation	RB No.	RB offset	MPR	Conducted Output Power (dBm)	RF Output Power (W) EIRP	Limit (W) EIRP		
Band 66 / 3MHz	CH 131987 / 1711.5MHz	QPSK	1	0	0	23.07	0.454	1		
				7		23.05	0.452	1		
				14		22.97	0.444	1		
			8	0	1	22.29	0.379	1		
				4		22.26	0.377	1		
				7		22.24	0.375	1		
			15	0	1	22.21	0.372	1		
			16-QAM	1	1	0	1	22.42	0.391	1
						7		22.36	0.385	1
		14				22.36		0.385	1	
		8			0	2	21.22	0.296	1	
					4		21.23	0.297	1	
					7		21.28	0.301	1	
		15	0	2	21.20	0.295	1			

Band	Channel Freq. (MHz)	Modulation	RB No.	RB offset	MPR	Conducted Output Power (dBm)	RF Output Power (W) EIRP	Limit (W) EIRP	
Band 66 / 3MHz	CH 132322 1745MHz	QPSK	1	0	0	23.78	0.535	1	
				7		23.74	0.530	1	
				14		23.72	0.527	1	
			8	0	1	22.90	0.437	1	
				4		22.86	0.433	1	
				7		22.80	0.427	1	
			15	0	1	22.81	0.428	1	
			16-QAM	1	1	0	22.95	0.442	1
						7	22.90	0.437	1
		14				22.89	0.436	1	
		8		2	0	22.08	0.361	1	
					4	22.06	0.360	1	
					7	22.05	0.359	1	
		15	0	2	21.90	0.347	1		

Band	Channel Freq. (MHz)	Modulation	RB No.	RB offset	MPR	Conducted Output Power (dBm)	RF Output Power (W) EIRP	Limit (W) EIRP	
Band 66 / 3MHz	CH 132657 1778.5MHz	QPSK	1	0	0	23.78	0.535	1	
				7		23.76	0.532	1	
				14		23.75	0.531	1	
			8	0	1	23.08	0.455	1	
				4		23.04	0.451	1	
				7		23.05	0.452	1	
			15	0	1	22.92	0.439	1	
			16-QAM	1	1	0	23.20	0.468	1
						7	23.18	0.466	1
		14				23.18	0.466	1	
		8		2	0	22.16	0.368	1	
					4	22.10	0.363	1	
					7	22.07	0.361	1	
		15	0	2	22.06	0.360	1		

Product	LE910C1-SA		
Test Item	RF Output Power		
Test Mode	Mode 5: LTE Band 66		
Date of Test	2018/12/12	Test Site	SR10-H

Band	Channel Freq. (MHz)	Modulation	RB No.	RB offset	MPR	Conducted Output Power (dBm)	RF Output Power (W) EIRP	Limit (W) EIRP		
Band 66 / 5MHz	CH 131997 / 1712.5MHz	QPSK	1	0	0	23.06	0.453	1		
				12		23.03	0.450	1		
				24		23.03	0.450	1		
			12	0	1	22.24	0.375	1		
				6		22.18	0.370	1		
				11		22.17	0.369	1		
			25	0	1	22.08	0.361	1		
			16-QAM	1	1	0	1	21.79	0.338	1
						12		21.74	0.334	1
		24				21.76		0.336	1	
		12			0	2	21.39	0.308	1	
					6		21.38	0.308	1	
					11		21.41	0.310	1	
		25	0	2	21.29	0.301	1			

Band	Channel Freq. (MHz)	Modulation	RB No.	RB offset	MPR	Conducted Output Power (dBm)	RF Output Power (W) EIRP	Limit (W) EIRP	
Band 66 / 5MHz	CH 132322 1745MHz	QPSK	1	0	0	23.70	0.525	1	
				12		23.65	0.519	1	
				24		23.66	0.520	1	
			12	0	1	22.87	0.434	1	
				6		22.90	0.437	1	
				11		22.93	0.440	1	
			25	0	1	22.80	0.427	1	
			16-QAM	1	1	0	23.15	0.462	1
						12	23.12	0.459	1
		24				23.11	0.458	1	
		12		2	0	21.89	0.346	1	
					6	21.86	0.344	1	
					11	21.88	0.345	1	
		25	0	2	21.87	0.344	1		

Band	Channel Freq. (MHz)	Modulation	RB No.	RB offset	MPR	Conducted Output Power (dBm)	RF Output Power (W) EIRP	Limit (W) EIRP	
Band 66 / 5MHz	CH 132647 1777.5MHz	QPSK	1	0	0	23.88	0.547	1	
				12		23.80	0.537	1	
				24		23.77	0.533	1	
			12	0	1	23.08	0.455	1	
				6		23.03	0.450	1	
				11		23.00	0.447	1	
			25	0	1	22.98	0.445	1	
			16-QAM	1	1	0	22.74	0.421	1
						12	22.68	0.415	1
		24				22.67	0.414	1	
		12		2	0	22.00	0.355	1	
					6	22.04	0.358	1	
					11	22.06	0.360	1	
		25	0	2	21.94	0.350	1		

Product	LE910C1-SA		
Test Item	RF Output Power		
Test Mode	Mode 5: LTE Band 66		
Date of Test	2018/12/12	Test Site	SR10-H

Band	Channel Freq. (MHz)	Modulation	RB No.	RB offset	MPR	Conducted Output Power (dBm)	RF Output Power (W) EIRP	Limit (W) EIRP		
Band 66 / 10MHz	CH 132022 1715MHz	QPSK	1	0	0	23.11	0.458	1		
				24		23.03	0.450	1		
				49		23.00	0.447	1		
			25	0	1	22.12	0.365	1		
				12		22.11	0.364	1		
				24		22.13	0.366	1		
			50	0	1	22.03	0.357	1		
			16-QAM	1	1	0	1	22.58	0.406	1
						24		22.55	0.403	1
		49				22.52		0.400	1	
		27		2	0	2	21.15	0.292	1	
					12		21.26	0.299	1	
					23		21.30	0.302	1	

Band	Channel Freq. (MHz)	Modulation	RB No.	RB offset	MPR	Conducted Output Power (dBm)	RF Output Power (W) EIRP	Limit (W) EIRP	
Band 66 / 10MHz	CH 132322 1745MHz	QPSK	1	0	0	23.55	0.507	1	
				24		23.50	0.501	1	
				49		23.50	0.501	1	
			25	0	1	22.52	0.400	1	
				12		22.58	0.406	1	
				24		22.61	0.408	1	
			50	0	1	22.45	0.394	1	
			16-QAM	1	1	0	22.61	0.408	1
						24	22.58	0.406	1
		49				22.58	0.406	1	
		27		2	0	21.56	0.321	1	
					12	21.53	0.318	1	
					23	21.55	0.320	1	

Band	Channel Freq. (MHz)	Modulation	RB No.	RB offset	MPR	Conducted Output Power (dBm)	RF Output Power (W) EIRP	Limit (W) EIRP	
Band 66 / 10MHz	CH 132622 1775MHz	QPSK	1	0	0	23.78	0.535	1	
				24		23.72	0.527	1	
				49		23.66	0.520	1	
			25	0	1	22.92	0.439	1	
				12		22.87	0.434	1	
				24		22.75	0.422	1	
			50	0	1	22.76	0.423	1	
			16-QAM	1	1	0	23.08	0.455	1
						24	23.05	0.452	1
		49				23.00	0.447	1	
		27		2	0	22.02	0.356	1	
					12	22.01	0.356	1	
					23	22.05	0.359	1	

Product	LE910C1-SA		
Test Item	RF Output Power		
Test Mode	Mode 5: LTE Band 66		
Date of Test	2018/12/12	Test Site	SR10-H

Band	Channel Freq. (MHz)	Modulation	RB No.	RB offset	MPR	Conducted Output Power (dBm)	RF Output Power (W) EIRP	Limit (W) EIRP	
Band 66 / 15MHz	CH 132047 / 1717.5MHz	QPSK	1	0	0	23.03	0.450	1	
				37		22.89	0.436	1	
				74		22.91	0.438	1	
			36	0	1	22.08	0.361	1	
				19		22.06	0.360	1	
				38		22.08	0.361	1	
		75	0	1	21.93	0.349	1		
		16-QAM		1	1	0	22.32	0.382	1
						37	22.28	0.378	1
						74	22.29	0.379	1
				27	2	0	21.09	0.288	1
						24	21.10	0.288	1
48	21.22					0.296	1		

Band	Channel Freq. (MHz)	Modulation	RB No.	RB offset	MPR	Conducted Output Power (dBm)	RF Output Power (W) EIRP	Limit (W) EIRP	
Band 66 / 15MHz	CH 132322 1745MHz	QPSK	1	0	0	23.47	0.498	1	
				37		23.45	0.495	1	
				74		23.43	0.493	1	
			36	0	1	22.46	0.394	1	
				19		22.42	0.391	1	
				38		22.37	0.386	1	
			75	0	1	22.33	0.383	1	
			16-QAM	1	1	0	22.38	0.387	1
						37	22.33	0.383	1
		74				22.32	0.382	1	
		27		2	0	21.55	0.320	1	
					24	21.63	0.326	1	
					48	21.67	0.329	1	

Band	Channel Freq. (MHz)	Modulation	RB No.	RB offset	MPR	Conducted Output Power (dBm)	RF Output Power (W) EIRP	Limit (W) EIRP	
Band 66 / 15MHz	CH 132597 / 1772.5MHz	QPSK	1	0	0	23.56	0.508	1	
				37		23.53	0.505	1	
				74		23.52	0.504	1	
			36	0	1	22.47	0.395	1	
				19		22.41	0.390	1	
				38		22.35	0.385	1	
			75	0	1	22.36	0.385	1	
			16-QAM	1	1	0	23.02	0.449	1
						37	22.98	0.445	1
		74				22.97	0.444	1	
		27		2	0	21.71	0.332	1	
					24	21.78	0.337	1	
					48	21.83	0.341	1	

Product	LE910C1-SA		
Test Item	RF Output Power		
Test Mode	Mode 5: LTE Band 66		
Date of Test	2018/12/12	Test Site	SR10-H

Band	Channel Freq. (MHz)	Modulation	RB No.	RB offset	MPR	Conducted Output Power (dBm)	RF Output Power (W) EIRP	Limit (W) EIRP		
Band 66 / 20MHz	CH 132072 1720MHz	QPSK	1	0	0	23.17	0.465	1		
				49		23.07	0.454	1		
				99		23.09	0.456	1		
			50	0	1	22.08	0.361	1		
				25		22.20	0.372	1		
				49		22.26	0.377	1		
			100	0	1	22.09	0.362	1		
			16-QAM	1	1	0	1	22.79	0.426	1
						49		22.76	0.423	1
		99				22.72		0.419	1	
		27		2	0	2	21.02	0.283	1	
					36		21.11	0.289	1	
					73		21.20	0.295	1	

Band	Channel Freq. (MHz)	Modulation	RB No.	RB offset	MPR	Conducted Output Power (dBm)	RF Output Power (W) EIRP	Limit (W) EIRP	
Band 66 / 20MHz	CH 132322 1745MHz	QPSK	1	0	0	23.49	0.500	1	
				49		23.40	0.490	1	
				99		23.41	0.491	1	
			50	0	1	22.52	0.400	1	
				25		22.48	0.396	1	
				49		22.38	0.387	1	
			100	0	1	22.37	0.386	1	
			16-QAM	1	1	0	22.71	0.418	1
						49	22.62	0.409	1
		99				22.62	0.409	1	
		27		2	0	21.59	0.323	1	
					36	21.65	0.327	1	
					73	21.86	0.344	1	

Band	Channel Freq. (MHz)	Modulation	RB No.	RB offset	MPR	Conducted Output Power (dBm)	RF Output Power (W) EIRP	Limit (W) EIRP	
Band 66 / 20MHz	CH 132572 1770MHz	QPSK	1	0	0	23.75	0.531	1	
				49		23.70	0.525	1	
				99		23.72	0.527	1	
			50	0	1	22.69	0.416	1	
				25		22.71	0.418	1	
				49		22.74	0.421	1	
			100	0	1	22.61	0.408	1	
			16-QAM	1	1	0	22.87	0.434	1
						49	22.84	0.431	1
		99				22.82	0.429	1	
		27		2	0	21.54	0.319	1	
					36	21.56	0.321	1	
					73	21.58	0.322	1	

4. Spurious Emissions

4.1. Test Setup

Conducted Spurious Measurement:

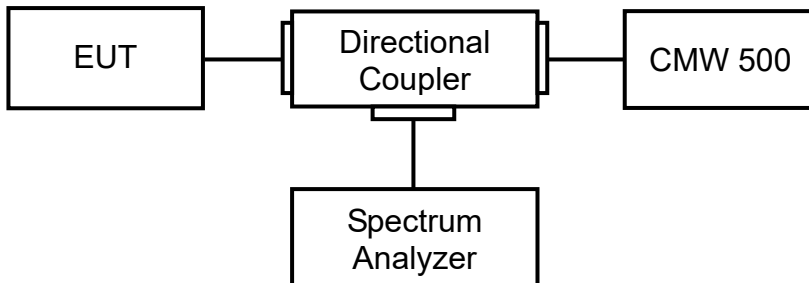

Radiated Spurious Measurement: below 1GHz

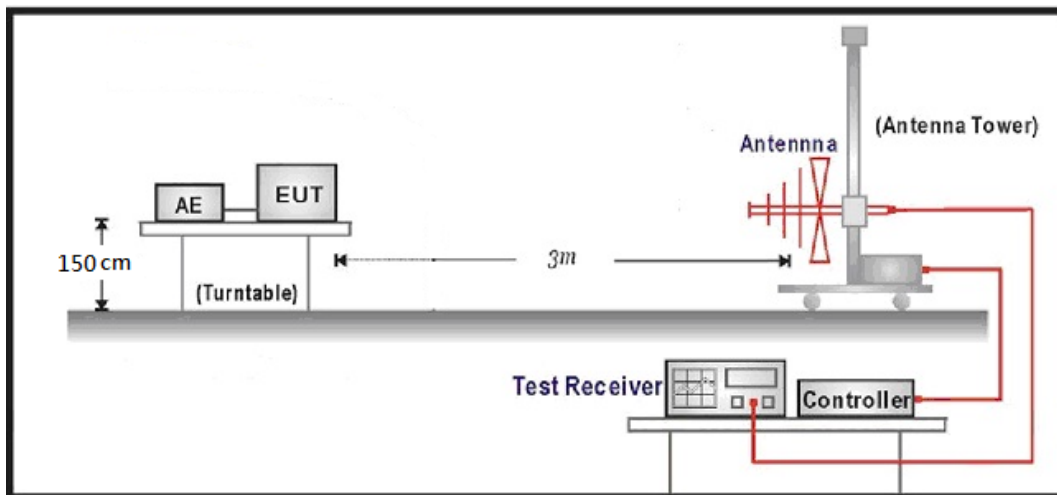

Radiated Spurious Measurement: above 1GHz

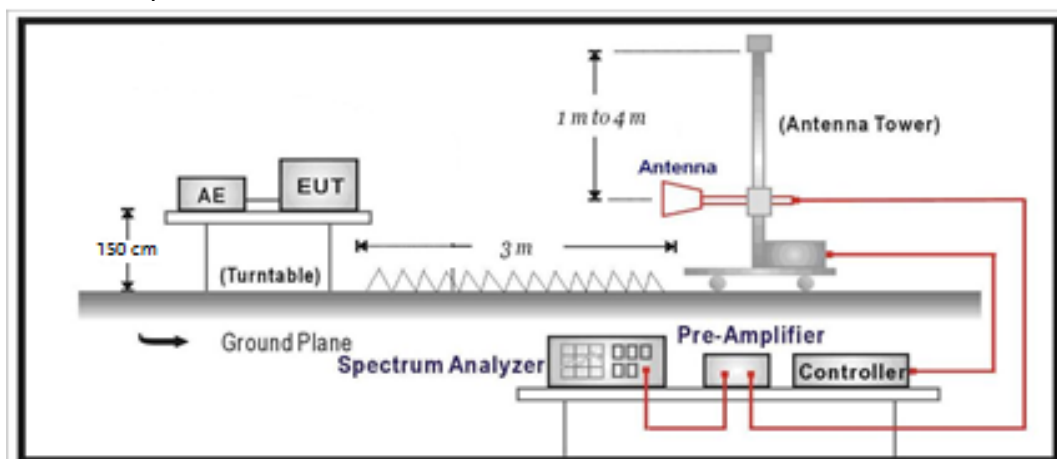

4.2. Test Procedure

Conducted Spurious Measurement:

- a) Place the EUT on a bench and set it in transmitting mode.
- b) Connect a low loss RF cable from the antenna port to a spectrum analyzer and CMW500 by a Directional Couple.
- c) EUT Communicate with CMW500, then select a channel for testing.
- d) Add a correction factor to the display of spectrum, and then test.
- e) The resolution bandwidth of the spectrum analyzer was set at 1 MHz, sufficient scans were taken to show the out of band Emission if any up to 10th harmonic.

Radiated Spurious Measurement:

- a) The EUT was placed on a rotatable wooden table with 1.5 meter above ground.
- b) The EUT was set 3 meters from the receiving antenna, which was mounted on the antenna tower.
- c) The table was rotated 360 degrees to determine the position of the highest spurious emission.
- d) The height of the receiving antenna is varied between one meter and four meters to search the maximum spurious emission for both horizontal and vertical polarizations.
- e) Make the measurement with the spectrum analyzer's RBW = 1MHz, VBW = 1MHz, Sweep 500ms, Taking the record of maximum spurious emission.
- f) A horn antenna was substituted in place of the EUT and was driven by a signal generator.
- g) Tune the output power of signal generator to the same emission level with EUT maximum spurious emission.
- h) Taking the record of output power at antenna port
- i) Repeat step 7 to step 8 for another polarization.
- j) $EIRP = SG - \text{Cable loss} + \text{Antenna Gain}$

4.3. Test Method

Conducted Spurious Measurement:

KDB 971168 D01 Power Meas License Digital Systems v03 sub-clause 6.1
ANSI C63.26: 2015 Sub-clause 5.7

Radiated Spurious Measurement:

KDB 971168 D01 Power Meas License Digital Systems v03 sub-clause 5.8
ANSI C63.26: 2015 Sub-clause 5.5.3.2

4.4. Test Result

Product	LE910C1-SA		
Test Item	Conducted Spurious Emissions		
Test Mode	Mode 1: LTE Band 2		
Date of Test	2018/12/10	Test Site	SR10-H

CH18607_1.4M_QPSK_1RB0_under 1G

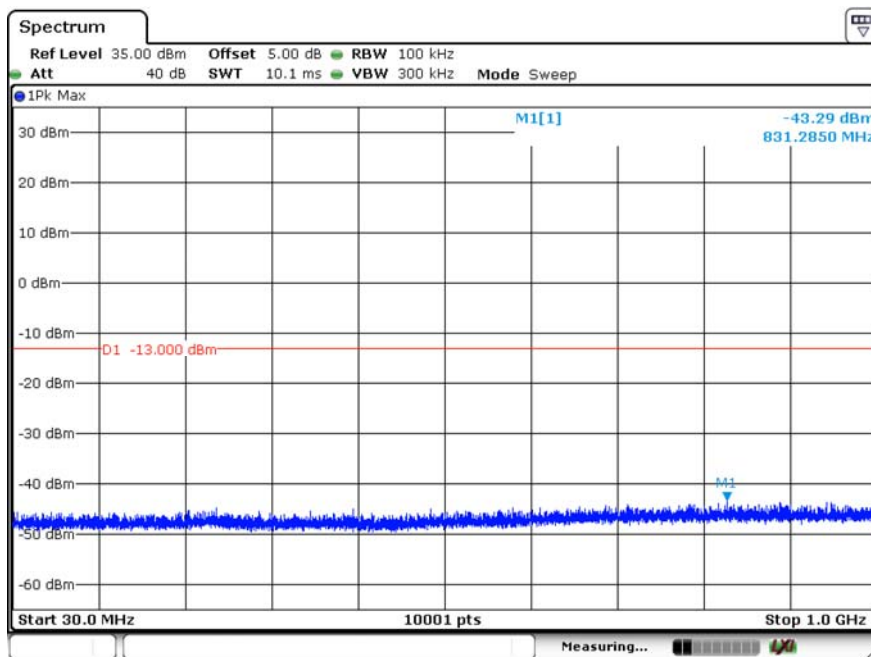

Date: 10.DEC.2018 22:39:50

CH18900_1.4M_QPSK_1RB0_under 1G

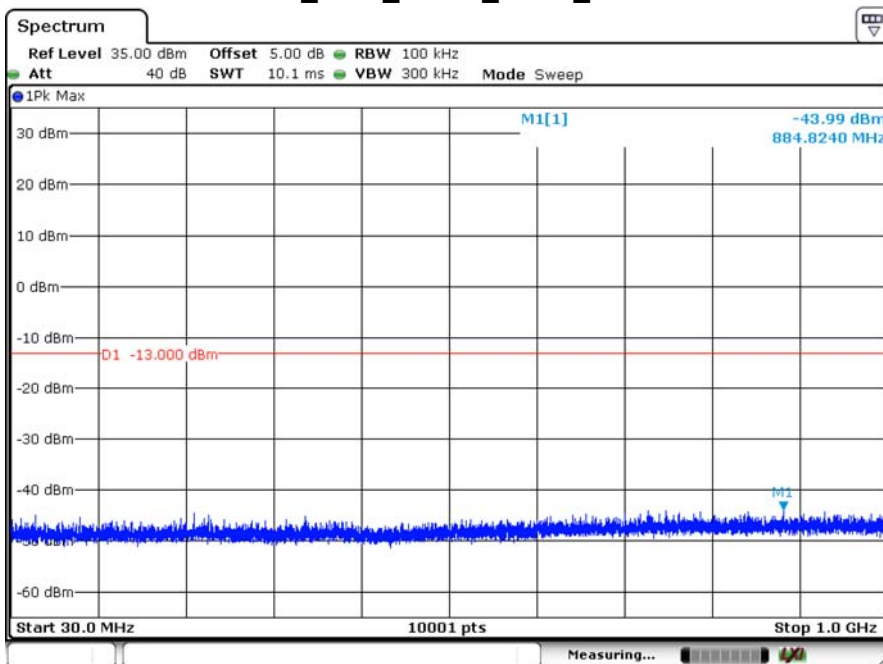

Date: 10.DEC.2018 22:41:19

CH19193_1.4M_QPSK_1RB0_under 1G

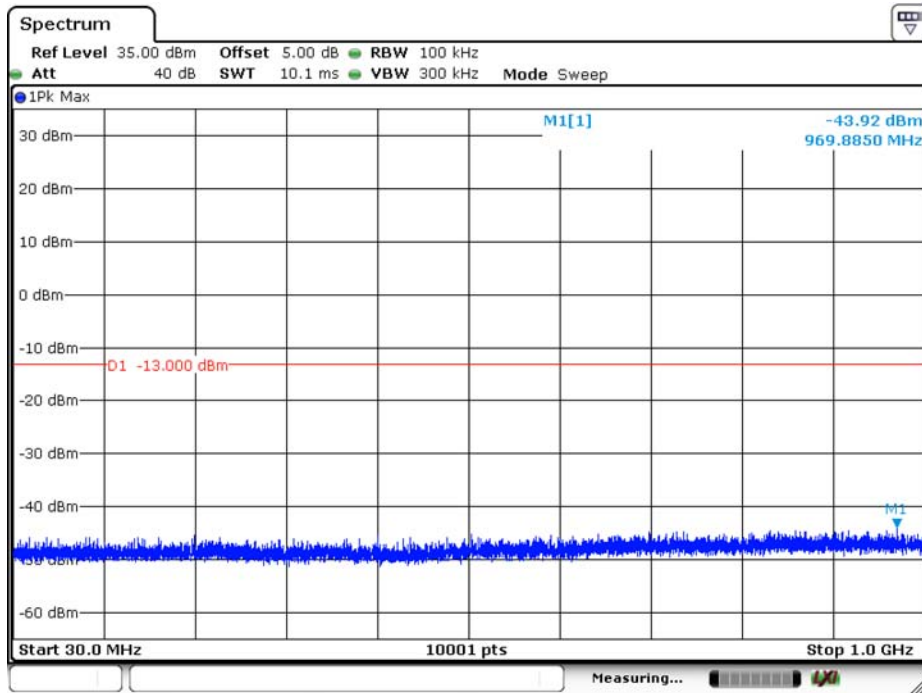

Date: 10.DEC.2018 22:42:19

CH18700_20M_QPSK_1RB0_under 1G

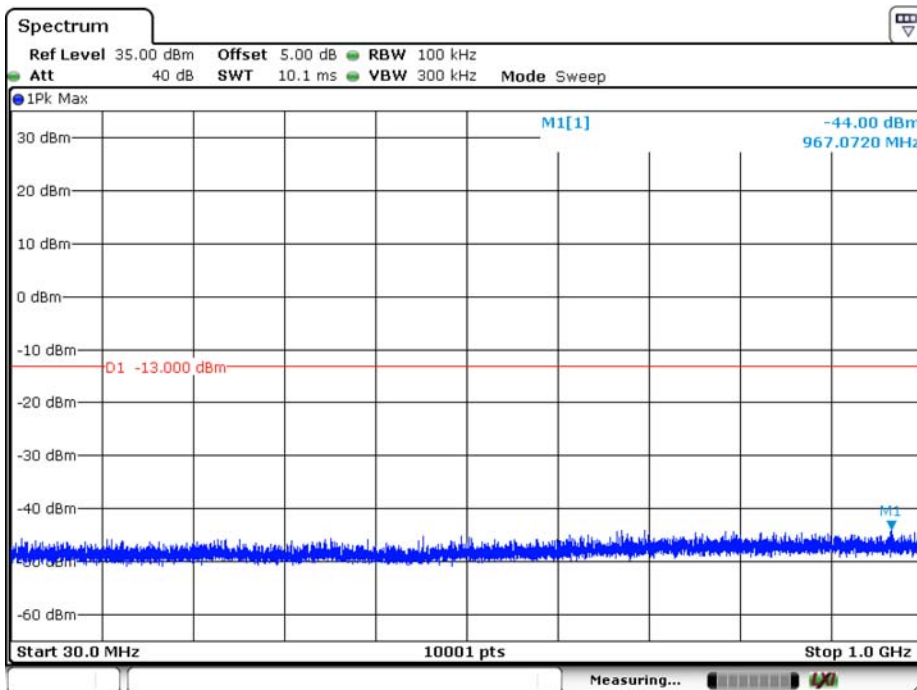

Date: 10.DEC.2018 22:43:20

CH18900_20M_QPSK_1RB0_under 1G

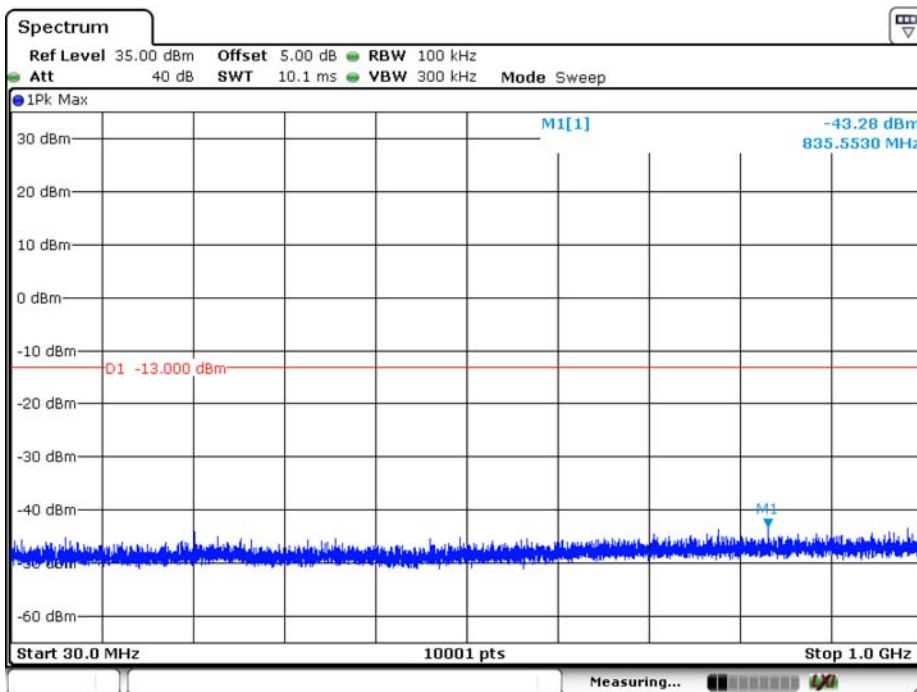

Date: 10.DEC.2018 22:44:03

CH19100_20M_QPSK_1RB0_under 1G

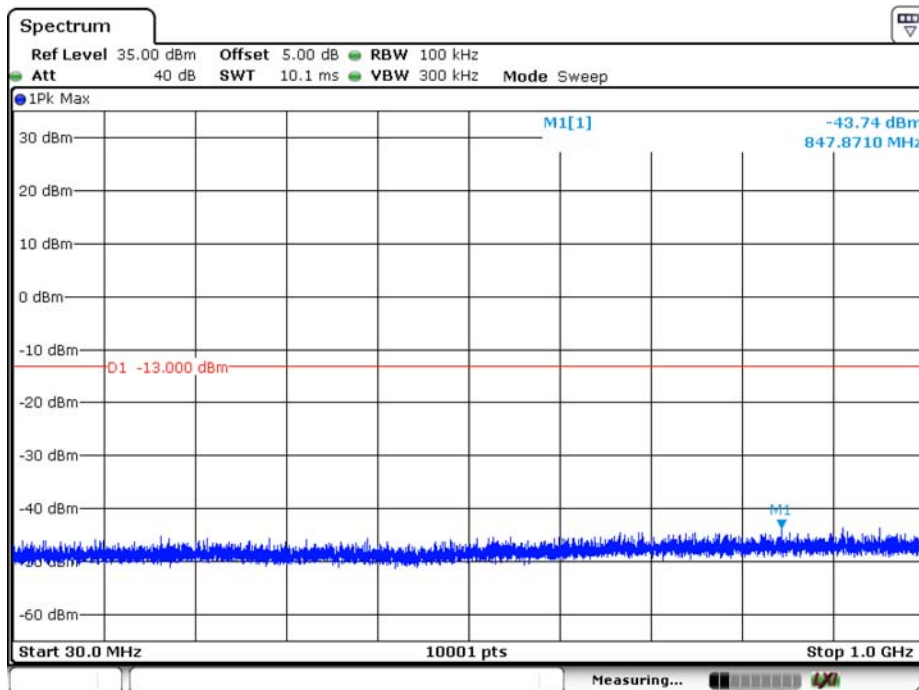

Date: 10.DEC.2018 22:44:38

Product	LE910C1-SA		
Test Item	Conducted Spurious Emissions		
Test Mode	Mode 2: LTE Band 4		
Date of Test	2018/12/10	Test Site	SR10-H

CH19957_1.4M_QPSK_1RB0_under 1G

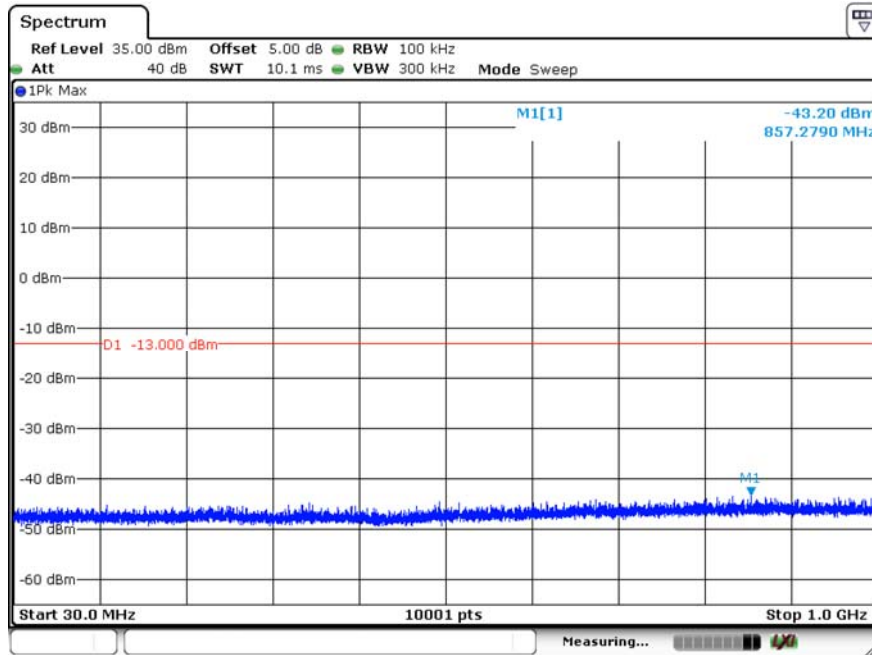

Date: 10.DEC.2018 22:47:24

CH20175_1.4M_QPSK_1RB0_under 1G

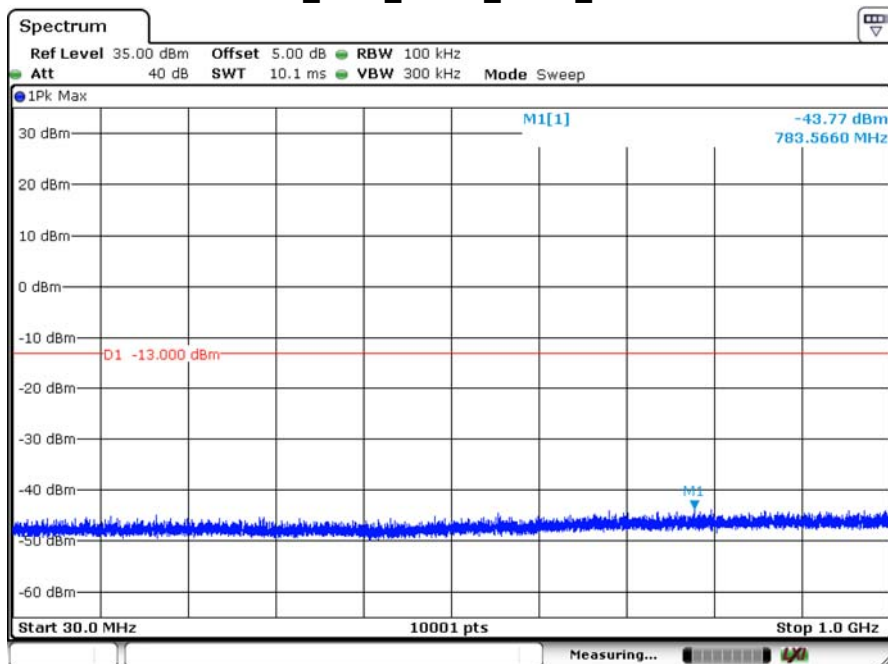

Date: 10.DEC.2018 22:48:41

CH20393_1.4M_QPSK_1RB0_under 1G

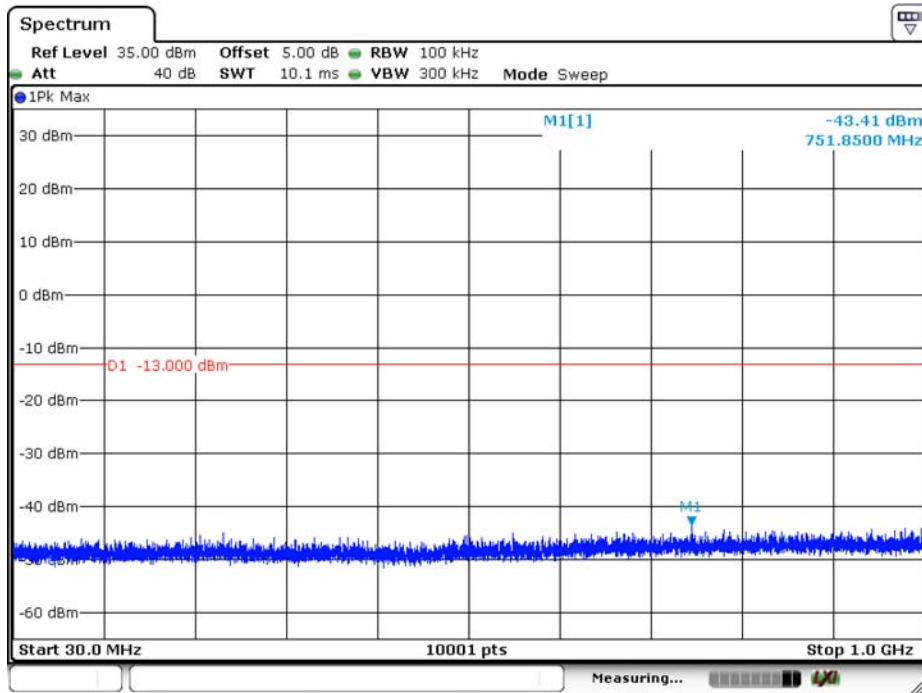

Date: 10.DEC.2018 22:49:10

CH20050_20M_QPSK_1RB0_under 1G

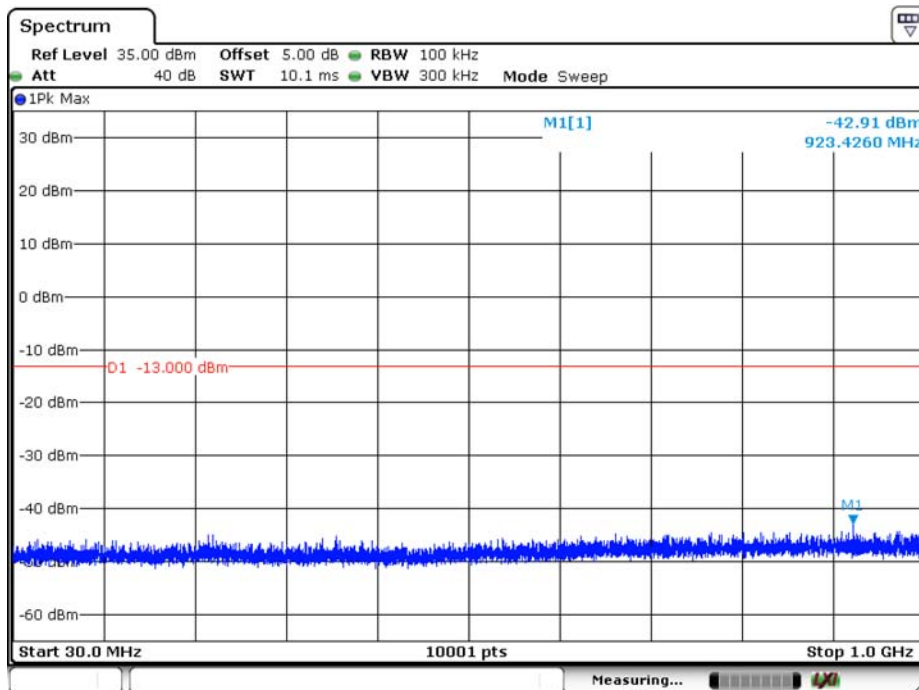

Date: 10.DEC.2018 22:49:54

CH20175_20M_QPSK_1RB0_under 1G

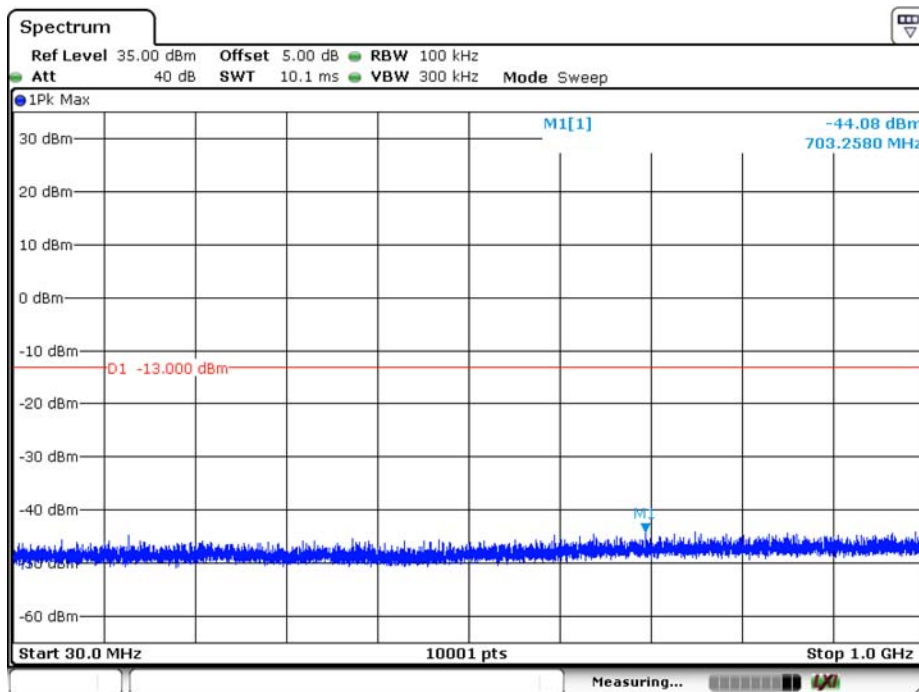

Date: 10.DEC.2018 22:50:32

CH20300_20M_QPSK_1RB0_under 1G

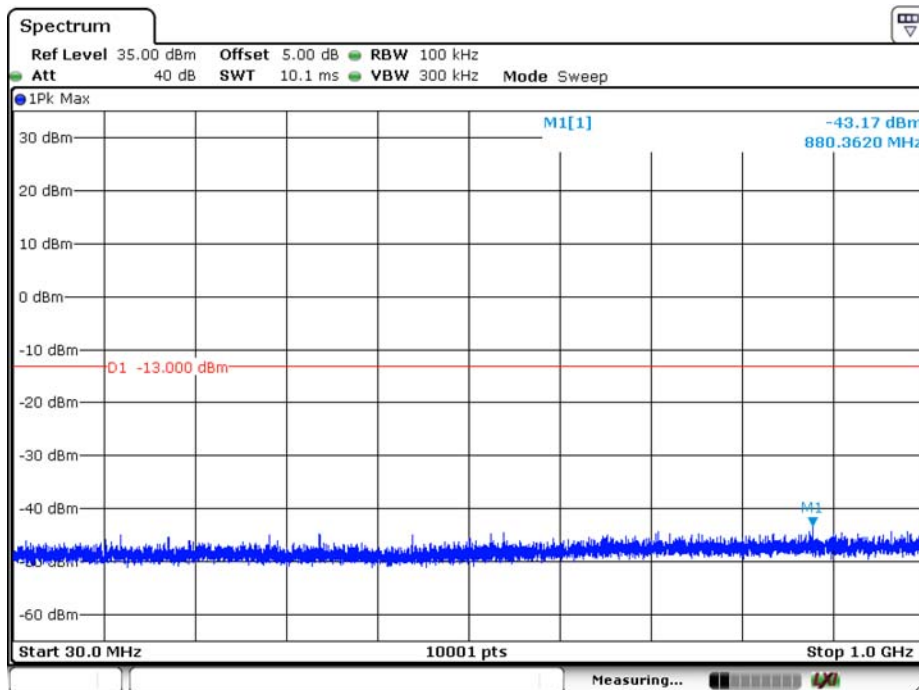

Date: 10.DEC.2018 22:50:56

Product	LE910C1-SA		
Test Item	Conducted Spurious Emissions		
Test Mode	Mode 3: LTE Band 12		
Date of Test	2018/12/10	Test Site	SR10-H

CH23017_1.4M_QPSK_1RB0_under 1G

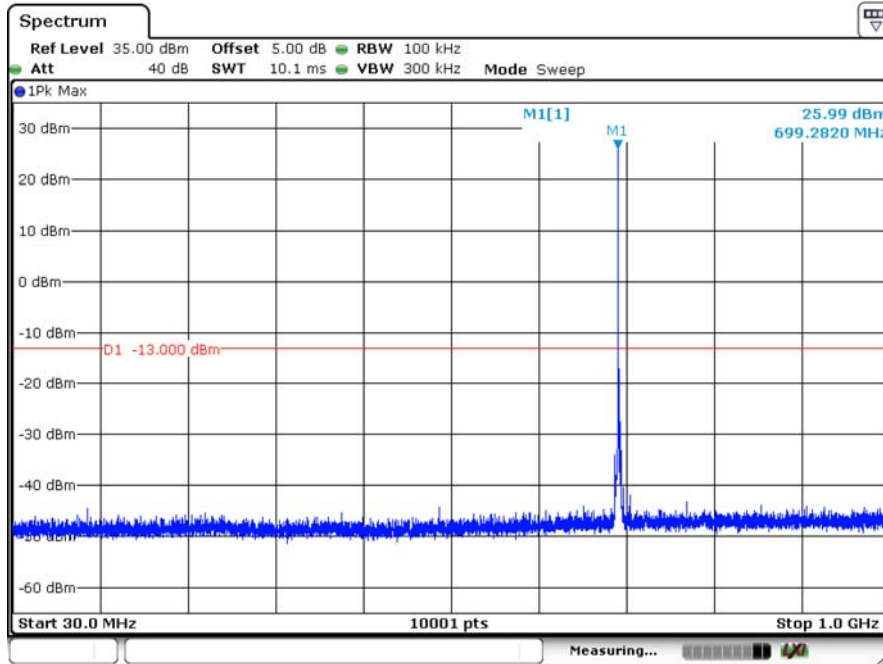

CH23095_1.4M_QPSK_1RB0_under 1G

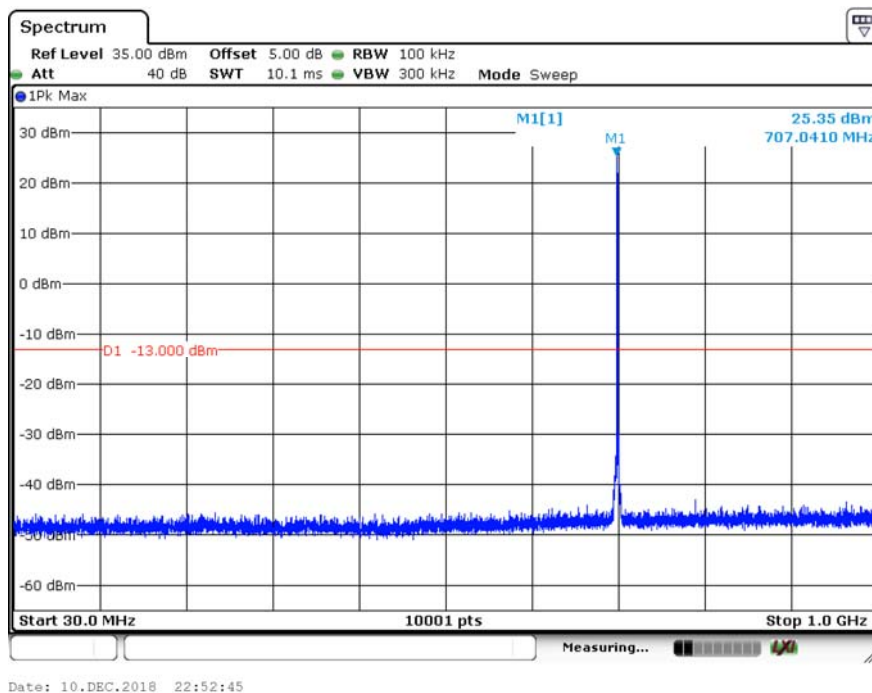

CH23173_1.4M_QPSK_1RB0_under 1G

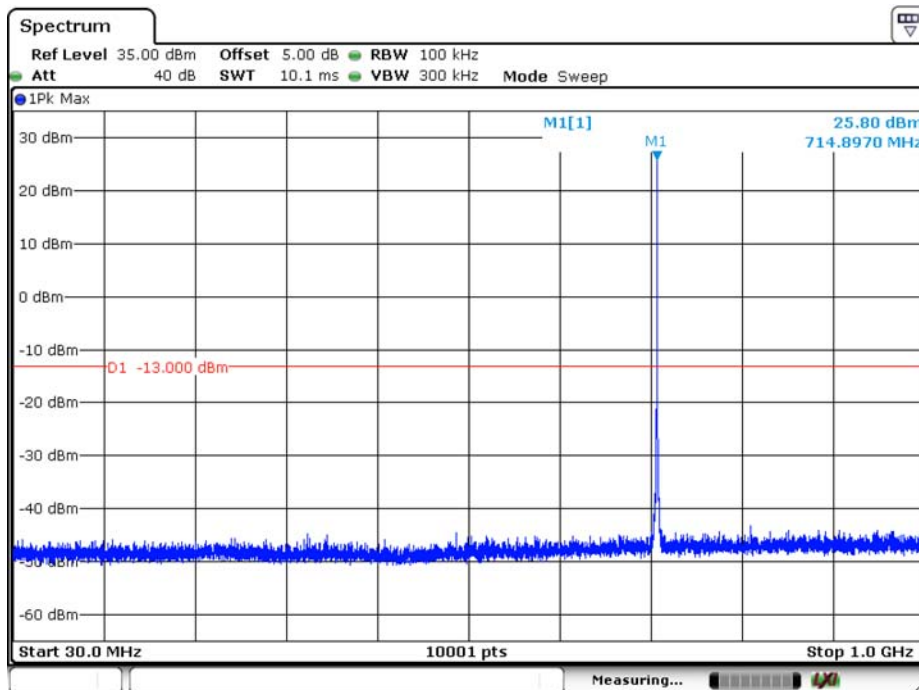

Date: 10.DEC.2018 22:54:04

CH23060_10M_QPSK_1RB0_under 1G

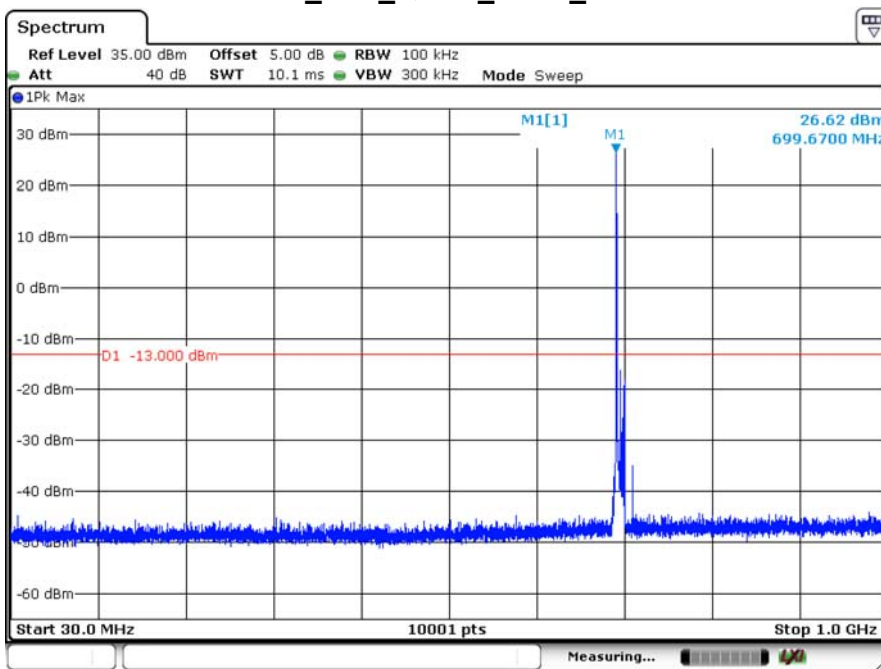

Date: 10.DEC.2018 22:59:41

CH23095_10M_QPSK_1RB0_under 1G

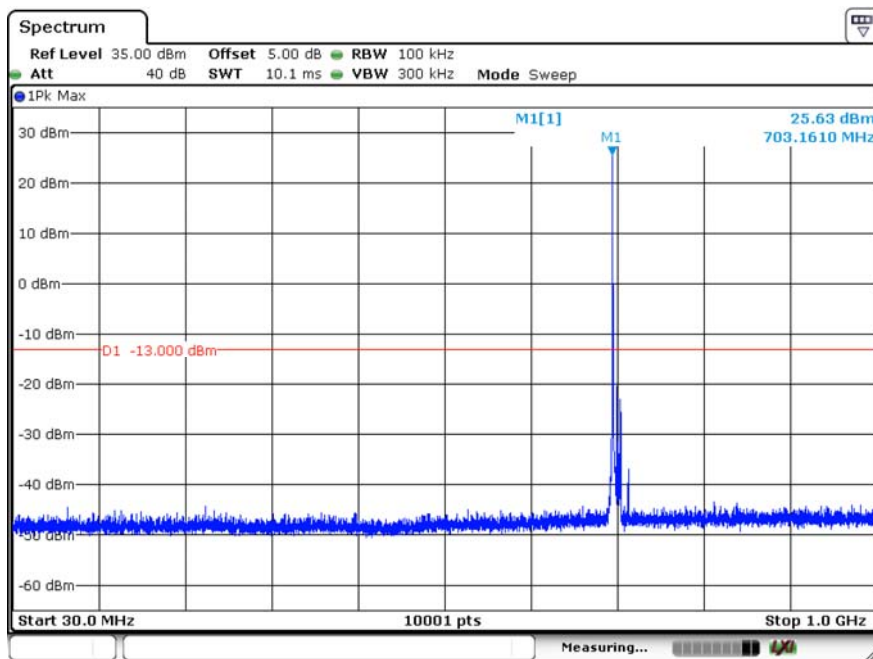

Date: 10.DEC.2018 22:59:08

CH23130_10M_QPSK_1RB0_under 1G

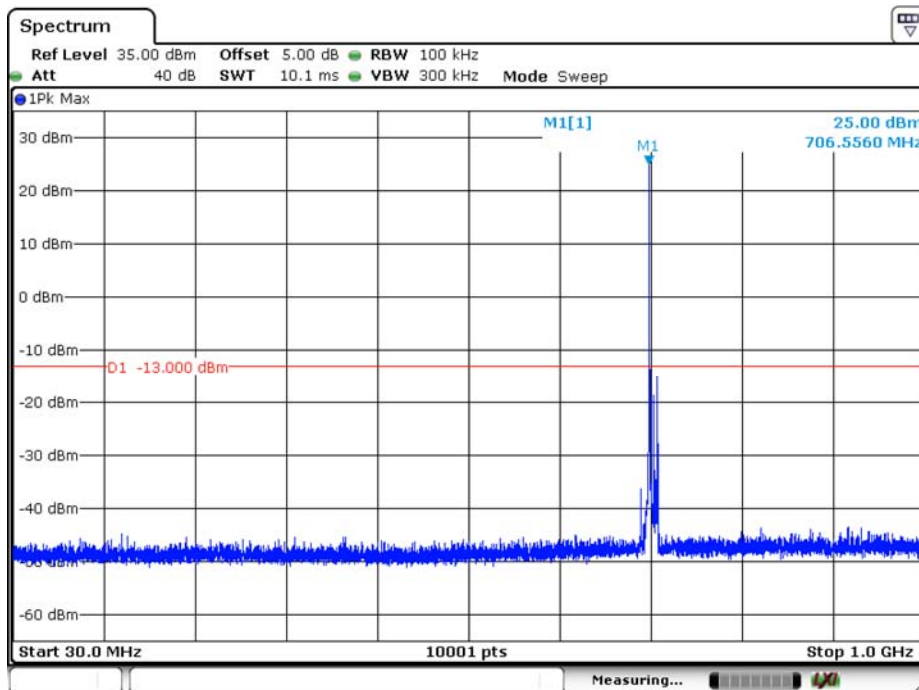

Date: 10.DEC.2018 23:00:05

Product	LE910C1-SA		
Test Item	Conducted Spurious Emissions		
Test Mode	Mode 4: LTE Band 14		
Date of Test	2018/12/10	Test Site	SR10-H

CH23305_5M_QPSK_1RB0_under 1G

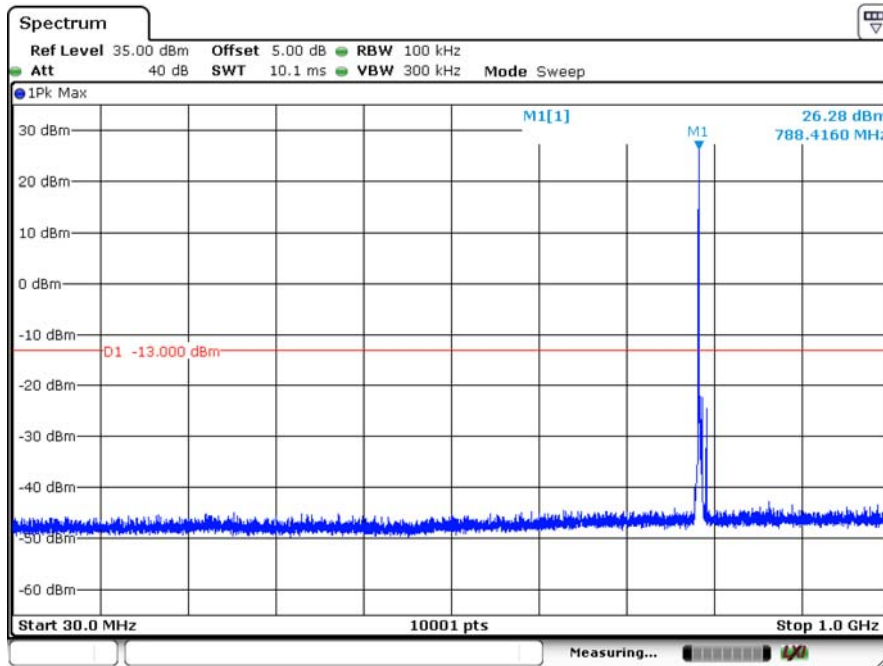

Date: 10.DEC.2018 23:01:38

CH23330_5M_QPSK_1RB0_under 1G

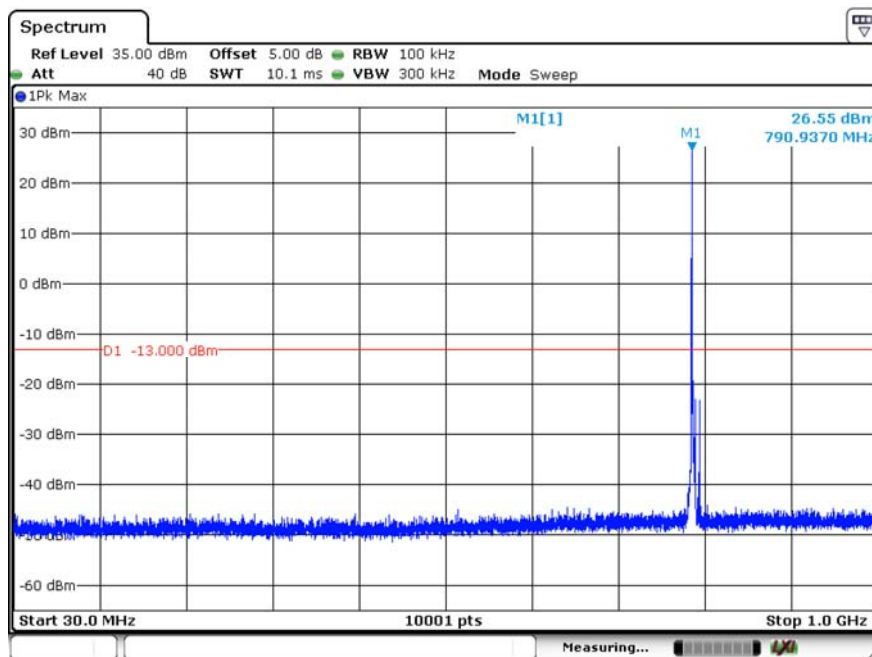

Date: 10.DEC.2018 23:02:18

CH23355_5M_QPSK_1RB0_under 1G

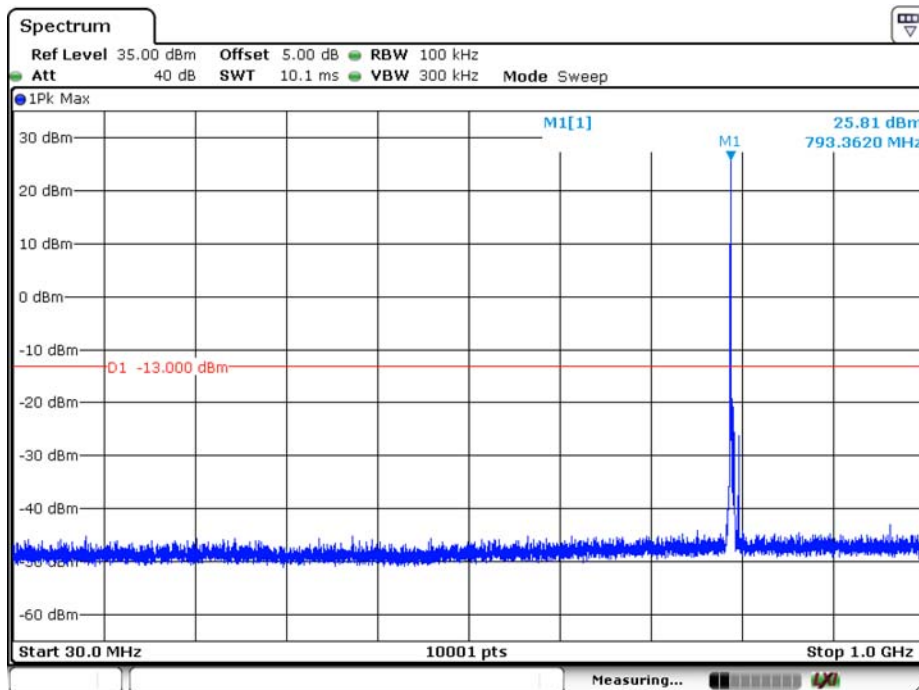

CH23330_10M_QPSK_1RB0_under 1G

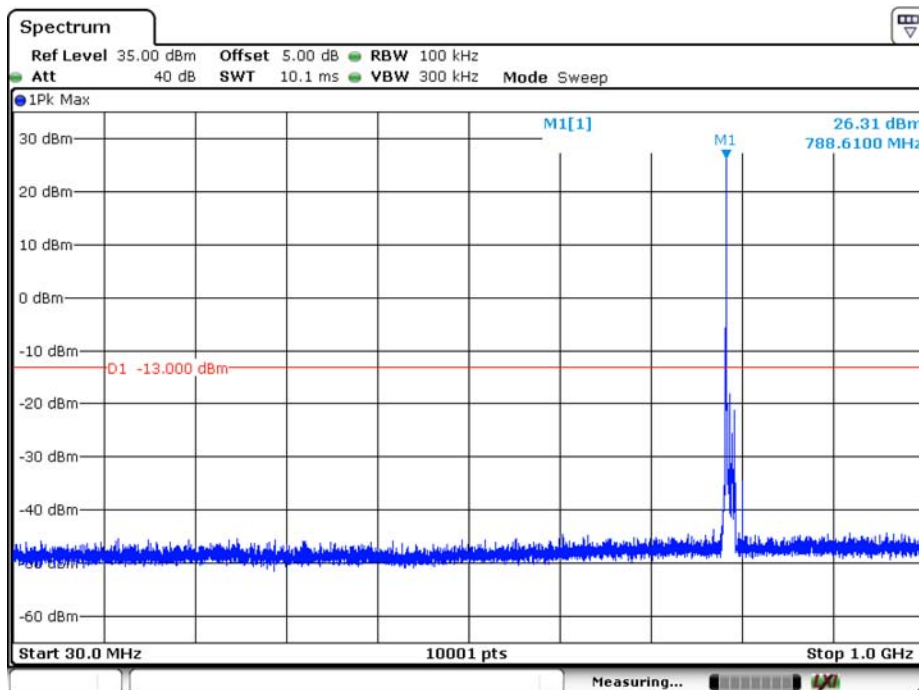

Product	LE910C1-SA		
Test Item	Conducted Spurious Emissions		
Test Mode	Mode 4: LTE Band 14 (GPS Band)		
Date of Test	2018/12/10	Test Site	SR10-H

CH23330_5M_1RB0_QPSK(GPS)

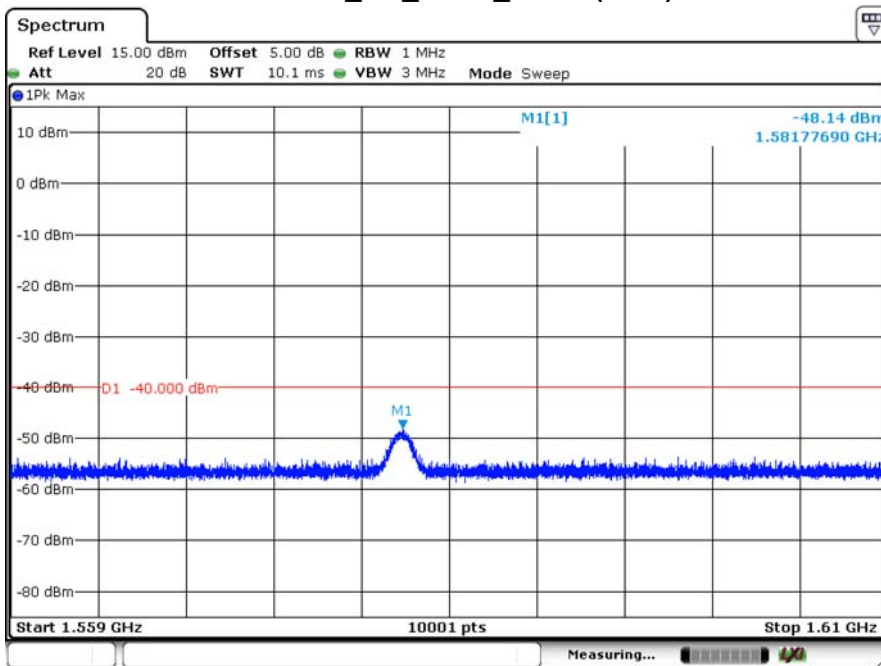

Date: 10.DEC.2018 23:39:06

CH23330_5M_1RB0_16-QAM(GPS)

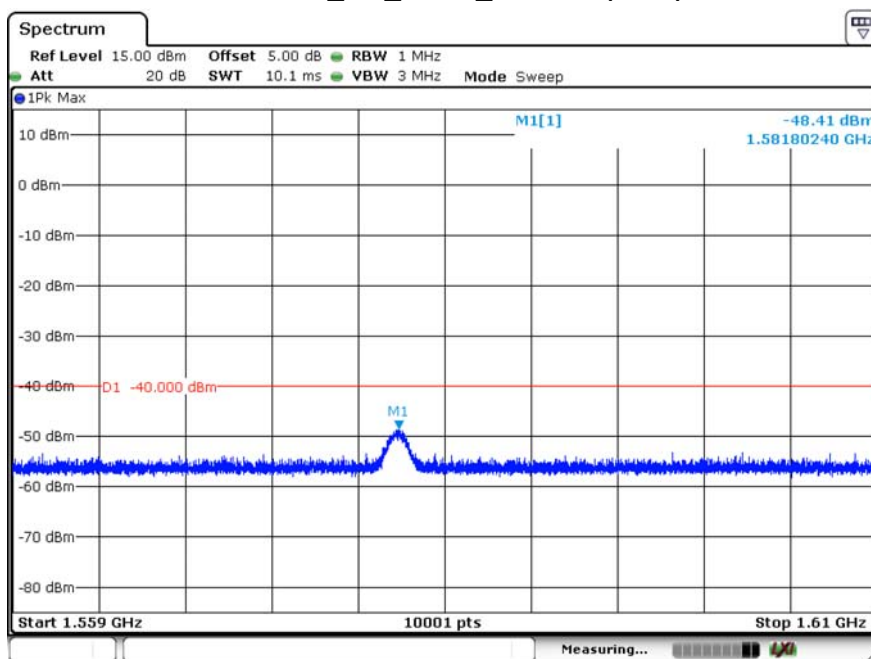

Date: 10.DEC.2018 23:39:52

CH23330_10M_1RB0_QPSK(GPS)

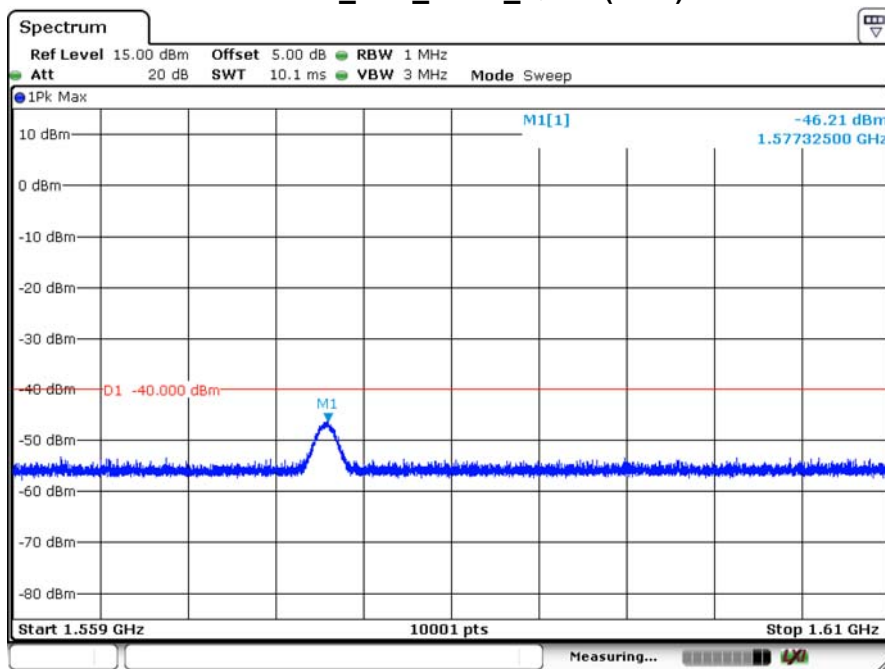

Date: 10.DEC.2018 23:37:37

CH23330_10M_1RB0_16-QAM(GPS)

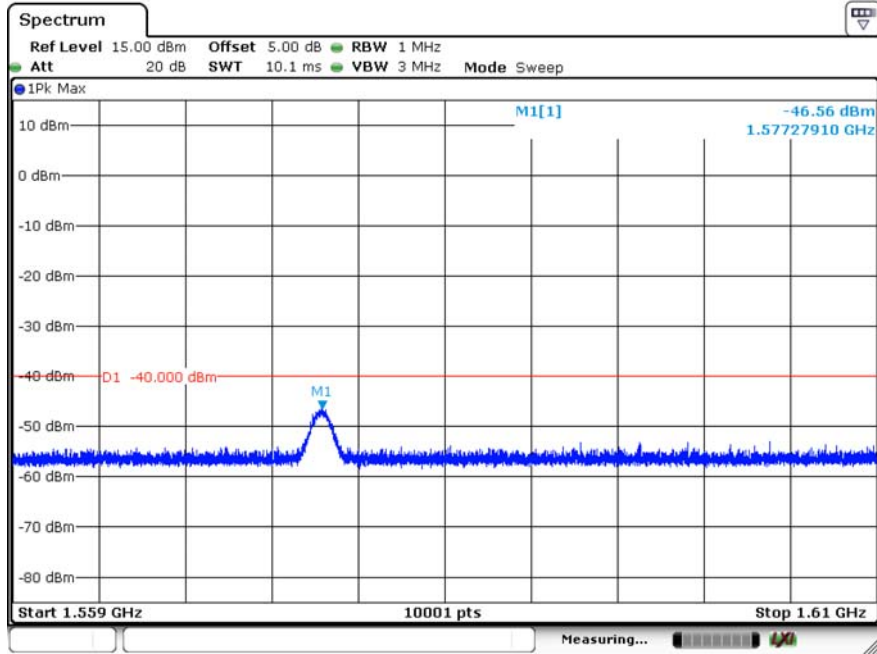

Date: 10.DEC.2018 23:38:02

Product	LE910C1-SA		
Test Item	Conducted Spurious Emissions		
Test Mode	Mode 5: LTE Band 66		
Date of Test	2018/12/10	Test Site	SR10-H

CH131979_1.4M_QPSK_1RB0_under 1G

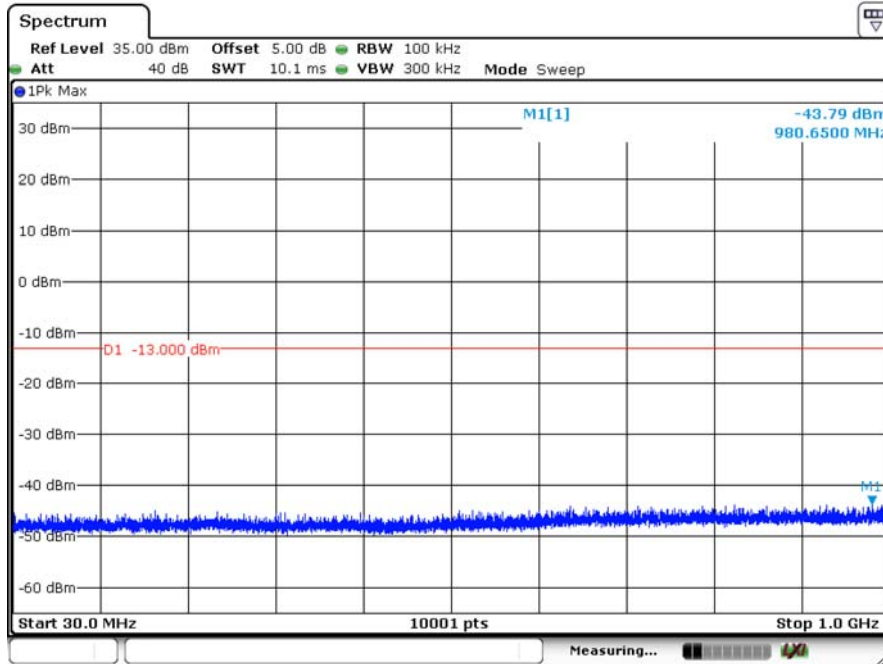

Date: 10.DEC.2018 23:05:02

CH132322_1.4M_QPSK_1RB0_under 1G

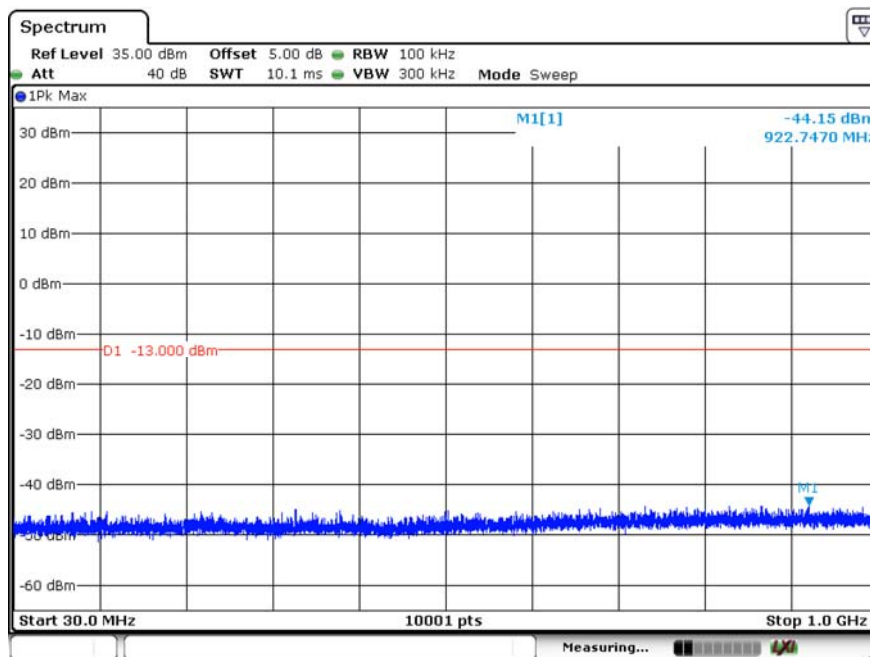

Date: 10.DEC.2018 23:05:47

CH132665_1.4M_QPSK_1RB0_under 1G

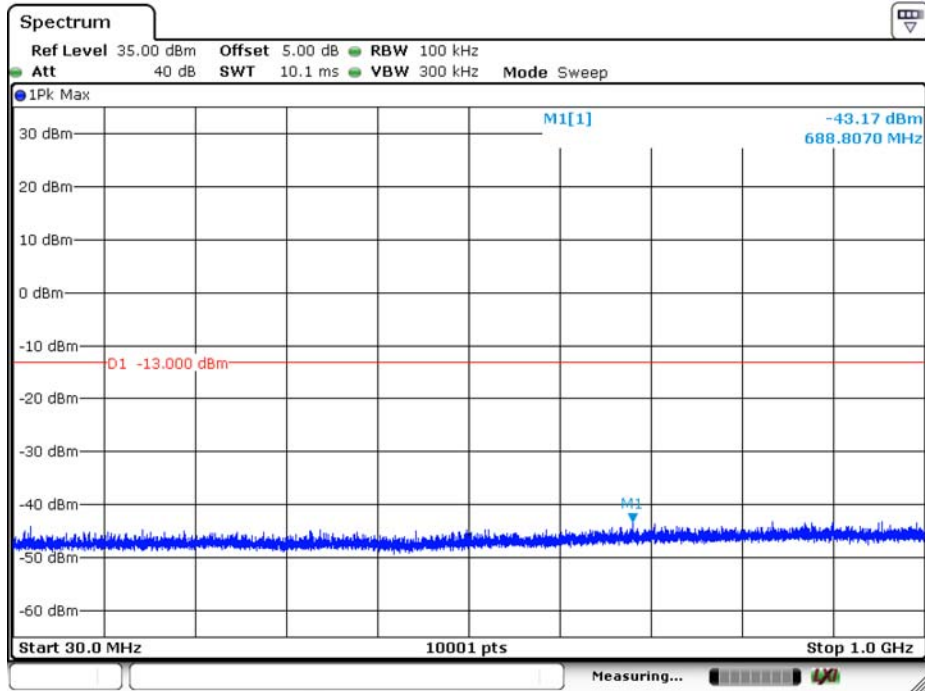

Date: 10.DEC.2018 23:07:09

CH132072_20M_QPSK_1RB0_under 1G

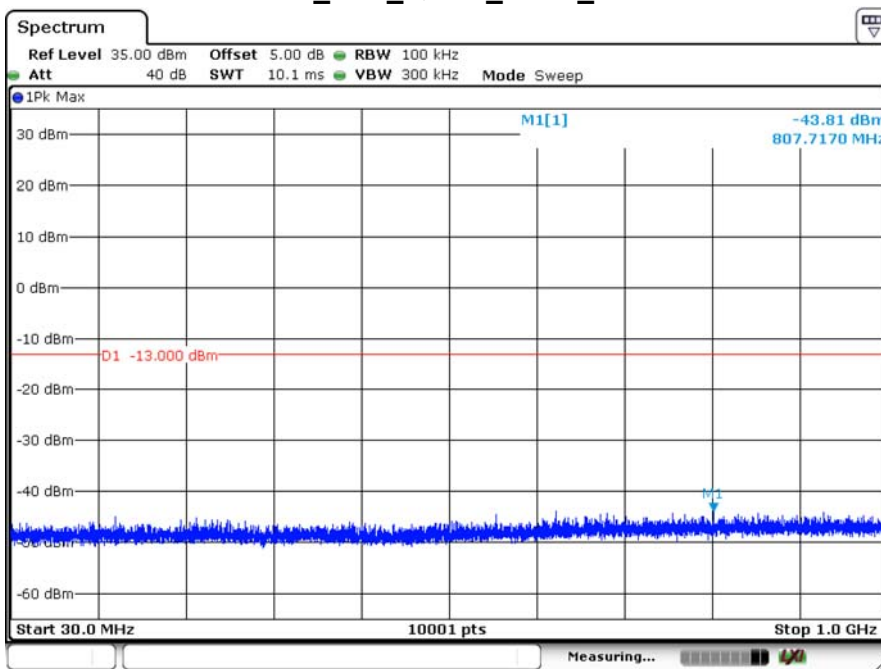

Date: 10.DEC.2018 23:08:19

CH132322_20M_QPSK_1RB0_under 1G

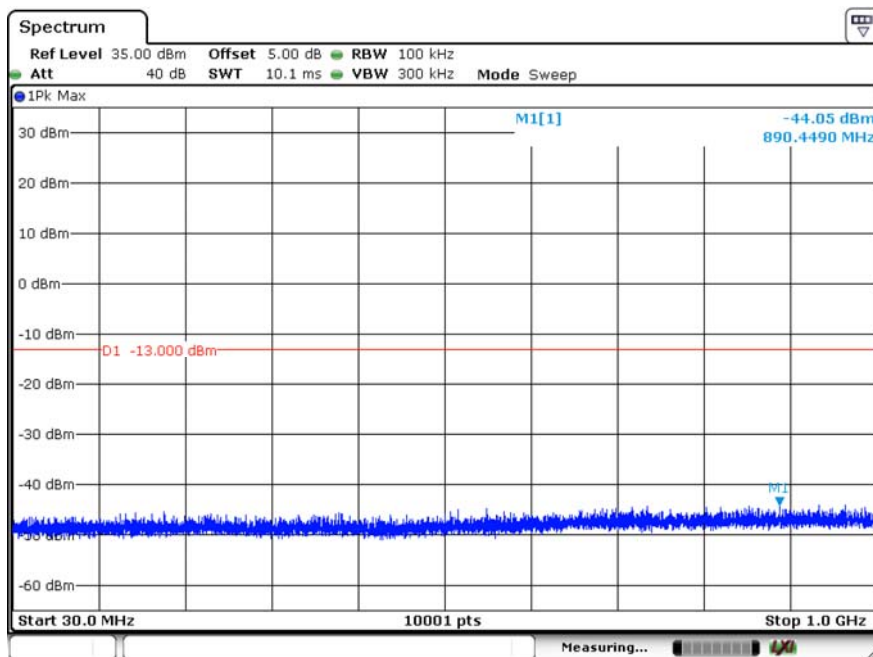

Date: 10.DEC.2018 23:08:48

CH132572_20M_QPSK_1RB0_under 1G

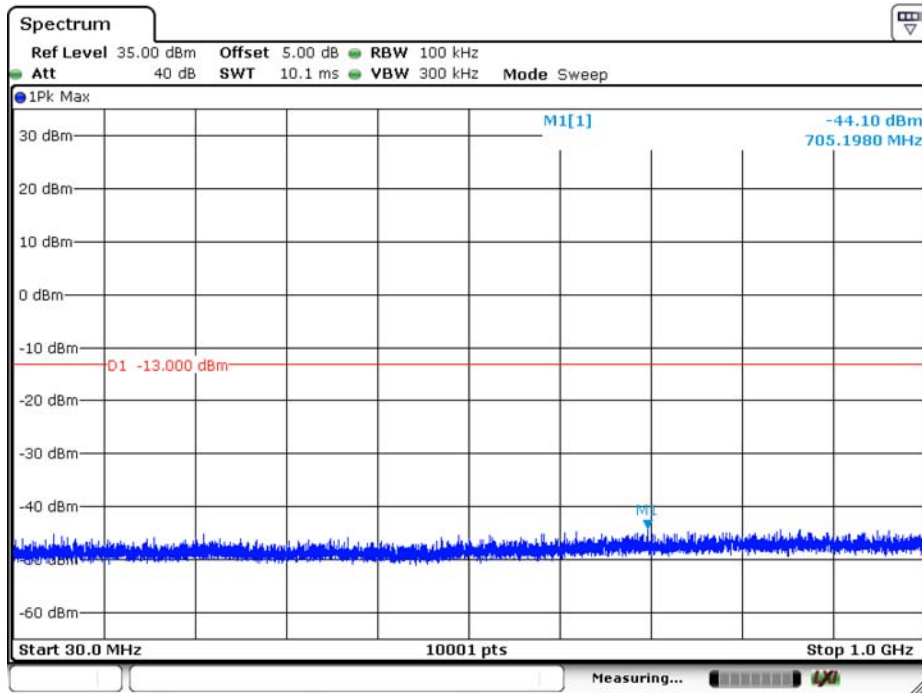

Date: 10.DEC.2018 23:09:21

Product	LE910C1-SA		
Test Item	Radiated Spurious Emissions		
Test Mode	Mode 1: LTE Band 2		
Date of Test	2018/12/11	Test Site	CB4-H

Frequency (MHz)	SA Reading (dBm)	Ant.Pol. (H/V)	SG Reading (dBm)	Cable Loss (dB)	Gain (dBi)	EIRP (dBm)	Limit (dBm)	Margin (dB)
LTE_Band2_1.4M_CH18607_QPSK_1RB0								
3701.40	-62.720	H	-63.373	4.284	11.937	-55.720	-13	-42.720
5552.10	-63.430	H	-60.749	5.201	12.900	-53.050	-13	-40.050
3701.40	-61.020	V	-61.543	4.284	11.937	-53.890	-13	-40.890
5552.10	-56.270	V	-53.419	5.201	12.900	-45.720	-13	-32.720

Test Result (EIRP) = SG Level - Cable Loss + Antenna Gain.

Frequency (MHz)	SA Reading (dBm)	Ant.Pol. (H/V)	SG Reading (dBm)	Cable Loss (dB)	Gain (dBi)	EIRP (dBm)	Limit (dBm)	Margin (dB)
LTE_Band2_1.4M_CH18900_QPSK_1RB0								
3760.00	-62.880	H	-63.397	4.335	11.832	-55.900	-13	-42.900
5640.00	-59.940	H	-57.285	5.235	12.900	-49.620	-13	-36.620
3760.00	-63.840	V	-64.217	4.335	11.832	-56.720	-13	-43.720
5640.00	-53.810	V	-50.985	5.235	12.900	-43.320	-13	-30.320

Test Result (EIRP) = SG Level - Cable Loss + Antenna Gain.

Frequency (MHz)	SA Reading (dBm)	Ant.Pol. (H/V)	SG Reading (dBm)	Cable Loss (dB)	Gain (dBi)	EIRP (dBm)	Limit (dBm)	Margin (dB)
LTE_Band2_1.4M_CH19193_QPSK_1RB0								
3818.60	-62.470	H	-62.832	4.385	11.727	-55.490	-13	-42.490
5727.90	-58.750	H	-56.121	5.269	12.900	-48.490	-13	-35.490
3818.60	-62.370	V	-62.582	4.385	11.727	-55.240	-13	-42.240
5727.90	-51.200	V	-48.401	5.269	12.900	-40.770	-13	-27.770

Test Result (EIRP) = SG Level - Cable Loss + Antenna Gain.

Frequency (MHz)	SA Reading (dBm)	Ant.Pol. (H/V)	SG Reading (dBm)	Cable Loss (dB)	Gain (dBi)	EIRP (dBm)	Limit (dBm)	Margin (dB)
LTE_Band2_20M_CH18700_QPSK_1RB0								
3720.00	-62.930	H	-63.544	4.300	11.904	-55.940	-13	-42.940
5580.00	-63.490	H	-60.818	5.212	12.900	-53.130	-13	-40.130
3720.00	-62.500	V	-62.974	4.300	11.904	-55.370	-13	-42.370
5580.00	-57.910	V	-55.068	5.212	12.900	-47.380	-13	-34.380

Test Result (EIRP) = SG Level - Cable Loss + Antenna Gain.

Frequency (MHz)	SA Reading (dBm)	Ant.Pol. (H/V)	SG Reading (dBm)	Cable Loss (dB)	Gain (dBi)	EIRP (dBm)	Limit (dBm)	Margin (dB)
LTE_Band2_20M_CH18900_QPSK_1RB0								
3760.00	-61.360	H	-61.877	4.335	11.832	-54.380	-13	-41.380
5640.00	-58.240	H	-55.585	5.235	12.900	-47.920	-13	-34.920
3760.00	-61.580	V	-61.957	4.335	11.832	-54.460	-13	-41.460
5640.00	-53.140	V	-50.315	5.235	12.900	-42.650	-13	-29.650

Test Result (EIRP) = SG Level - Cable Loss + Antenna Gain.

Frequency (MHz)	SA Reading (dBm)	Ant.Pol. (H/V)	SG Reading (dBm)	Cable Loss (dB)	Gain (dBi)	EIRP (dBm)	Limit (dBm)	Margin (dB)
LTE_Band2_20M_CH19100_QPSK_1RB0								
3800.00	-64.680	H	-65.091	4.369	11.760	-57.700	-13	-44.700
5700.00	-65.950	H	-63.311	5.259	12.900	-55.670	-13	-42.670
3800.00	-63.880	V	-64.141	4.369	11.760	-56.750	-13	-43.750
5700.00	-60.000	V	-57.191	5.259	12.900	-49.550	-13	-36.550

Test Result (EIRP) = SG Level - Cable Loss + Antenna Gain.

Product	LE910C1-SA		
Test Item	Radiated Spurious Emissions		
Test Mode	Mode 2: LTE Band 4		
Date of Test	2018/12/11	Test Site	CB4-H

Frequency (MHz)	SA Reading (dBm)	Ant.Pol. (H/V)	SG Reading (dBm)	Cable Loss (dB)	Gain (dBi)	EIRP (dBm)	Limit (dBm)	Margin (dB)
LTE_Band4_1.4M_CH19957_QPSK_1RB0								
3421.40	-53.870	H	-55.141	4.064	12.096	-47.110	-13	-34.110
5132.10	-65.520	H	-63.203	5.075	12.238	-56.040	-13	-43.040
3421.40	-55.190	V	-56.301	4.064	12.096	-48.270	-13	-35.270
5132.10	-57.710	V	-55.233	5.075	12.238	-48.070	-13	-35.070

Test Result (EIRP) = SG Level - Cable Loss + Antenna Gain.

Frequency (MHz)	SA Reading (dBm)	Ant.Pol. (H/V)	SG Reading (dBm)	Cable Loss (dB)	Gain (dBi)	EIRP (dBm)	Limit (dBm)	Margin (dB)
LTE_Band4_1.4M_CH20175_QPSK_1RB0								
3465.00	-56.980	H	-58.209	4.090	12.209	-50.090	-13	-37.090
5197.50	-64.730	H	-62.352	5.094	12.356	-55.090	-13	-42.090
3465.00	-56.030	V	-57.129	4.090	12.209	-49.010	-13	-36.010
5197.50	-55.740	V	-53.192	5.094	12.356	-45.930	-13	-32.930

Test Result (EIRP) = SG Level - Cable Loss + Antenna Gain.

Frequency (MHz)	SA Reading (dBm)	Ant.Pol. (H/V)	SG Reading (dBm)	Cable Loss (dB)	Gain (dBi)	EIRP (dBm)	Limit (dBm)	Margin (dB)
LTE_Band4_1.4M_CH20393_QPSK_1RB0								
3508.60	-60.980	H	-62.146	4.118	12.285	-53.980	-13	-40.980
5262.90	-64.290	H	-61.841	5.113	12.473	-54.480	-13	-41.480
3508.60	-58.730	V	-59.796	4.118	12.285	-51.630	-13	-38.630
5262.90	-52.900	V	-50.281	5.113	12.473	-42.920	-13	-29.920

Test Result (EIRP) = SG Level - Cable Loss + Antenna Gain.

Frequency (MHz)	SA Reading (dBm)	Ant.Pol. (H/V)	SG Reading (dBm)	Cable Loss (dB)	Gain (dBi)	EIRP (dBm)	Limit (dBm)	Margin (dB)
LTE_Band4_20M_CH20050_QPSK_1RB0								
3440.00	-55.140	H	-56.399	4.075	12.144	-48.330	-13	-35.330
5160.00	-65.360	H	-63.015	5.083	12.288	-55.810	-13	-42.810
3440.00	-55.090	V	-56.189	4.075	12.144	-48.120	-13	-35.120
5160.00	-57.710	V	-55.205	5.083	12.288	-48.000	-13	-35.000

Test Result (EIRP) = SG Level - Cable Loss + Antenna Gain.

Frequency (MHz)	SA Reading (dBm)	Ant.Pol. (H/V)	SG Reading (dBm)	Cable Loss (dB)	Gain (dBi)	EIRP (dBm)	Limit (dBm)	Margin (dB)
LTE_Band4_20M_CH20175_QPSK_1RB0								
3465.00	-55.910	H	-57.139	4.090	12.209	-49.020	-13	-36.020
5197.50	-64.640	H	-62.262	5.094	12.356	-55.000	-13	-42.000
3465.00	-54.630	V	-55.729	4.090	12.209	-47.610	-13	-34.610
5197.50	-53.980	V	-51.432	5.094	12.356	-44.170	-13	-31.170

Test Result (EIRP) = SG Level - Cable Loss + Antenna Gain.

Frequency (MHz)	SA Reading (dBm)	Ant.Pol. (H/V)	SG Reading (dBm)	Cable Loss (dB)	Gain (dBi)	EIRP (dBm)	Limit (dBm)	Margin (dB)
LTE_Band4_20M_CH20300_QPSK_1RB0								
3490.00	-56.460	H	-57.669	4.105	12.274	-49.500	-13	-36.500
5235.00	-64.710	H	-62.288	5.105	12.423	-54.970	-13	-41.970
3490.00	-56.860	V	-57.959	4.105	12.274	-49.790	-13	-36.790
5235.00	-56.740	V	-54.148	5.105	12.423	-46.830	-13	-33.830

Test Result (EIRP) = SG Level - Cable Loss + Antenna Gain.

Product	LE910C1-SA		
Test Item	Radiated Spurious Emissions		
Test Mode	Mode 3: LTE Band 12		
Date of Test	2018/12/11	Test Site	CB4-H

Frequency (MHz)	SA Reading (dBm)	Ant.Pol. (H/V)	SG Reading (dBm)	Cable Loss (dB)	Gain (dBi)	EIRP (dBm)	Limit (dBm)	Margin (dB)
LTE_Band12_1.4M_CH23017_QPSK_1RB0								
1399.40	-53.800	H	-56.295	2.572	7.817	-51.050	-13	-38.050
2099.10	-52.730	H	-55.470	3.179	9.959	-48.690	-13	-35.690
1399.40	-52.620	V	-55.165	2.572	7.817	-49.920	-13	-36.920
2099.10	-51.730	V	-54.460	3.179	9.959	-47.680	-13	-34.680

Test Result (EIRP) = SG Level - Cable Loss + Antenna Gain.

Frequency (MHz)	SA Reading (dBm)	Ant.Pol. (H/V)	SG Reading (dBm)	Cable Loss (dB)	Gain (dBi)	EIRP (dBm)	Limit (dBm)	Margin (dB)
LTE_Band12_1.4M_CH23095_QPSK_1RB0								
1415.00	-57.870	H	-60.377	2.585	7.892	-55.070	-13	-42.070
2122.50	-40.360	H	-43.041	3.195	9.996	-36.240	-13	-23.240
1415.00	-57.570	V	-60.147	2.585	7.892	-54.840	-13	-41.840
2122.50	-37.790	V	-40.441	3.195	9.996	-33.640	-13	-20.640

Test Result (EIRP) = SG Level - Cable Loss + Antenna Gain.

Frequency (MHz)	SA Reading (dBm)	Ant.Pol. (H/V)	SG Reading (dBm)	Cable Loss (dB)	Gain (dBi)	EIRP (dBm)	Limit (dBm)	Margin (dB)
LTE_Band12_1.4M_CH23173_QPSK_1RB0								
1430.60	-51.420	H	-53.939	2.598	7.967	-48.570	-13	-35.570
2145.90	-46.780	H	-49.432	3.211	10.033	-42.610	-13	-29.610
1430.60	-50.740	V	-53.349	2.598	7.967	-47.980	-13	-34.980
2145.90	-43.910	V	-46.512	3.211	10.033	-39.690	-13	-26.690

Test Result (EIRP) = SG Level - Cable Loss + Antenna Gain.

Frequency	SA Reading (dBm)	Ant.Pol. (H/V)	SG Reading (dBm)	Cable Loss (dB)	Gain (dBi)	EIRP (dBm)	Limit (dBm)	Margin (dB)
LTE_Band12_10M_CH23060_QPSK_1RB0								
1408.00	-53.790	H	-56.279	2.579	7.858	-51.000	-13	-38.000
2112.00	-50.300	H	-53.012	3.188	9.979	-46.220	-13	-33.220
1408.00	-54.370	V	-56.919	2.579	7.858	-51.640	-13	-38.640
2112.00	-52.540	V	-55.232	3.188	9.979	-48.440	-13	-35.440

Test Result (EIRP) = SG Level - Cable Loss + Antenna Gain.

Frequency	SA Reading (dBm)	Ant.Pol. (H/V)	SG Reading (dBm)	Cable Loss (dB)	Gain (dBi)	EIRP (dBm)	Limit (dBm)	Margin (dB)
LTE_Band12_10M_CH23095_QPSK_1RB0								
1415.00	-56.600	H	-59.107	2.585	7.892	-53.800	-13	-40.800
2122.50	-50.530	H	-53.211	3.195	9.996	-46.410	-13	-33.410
1415.00	-54.150	V	-56.727	2.585	7.892	-51.420	-13	-38.420
2122.50	-48.300	V	-50.951	3.195	9.996	-44.150	-13	-31.150

Test Result (EIRP) = SG Level - Cable Loss + Antenna Gain.

Frequency	SA Reading (dBm)	Ant.Pol. (H/V)	SG Reading (dBm)	Cable Loss (dB)	Gain (dBi)	EIRP (dBm)	Limit (dBm)	Margin (dB)
LTE_Band12_10M_CH23130_QPSK_1RB0								
1422.00	-59.140	H	-61.645	2.591	7.926	-56.310	-13	-43.310
2133.00	-40.870	H	-43.551	3.202	10.013	-36.740	-13	-23.740
1422.00	-59.890	V	-62.475	2.591	7.926	-57.140	-13	-44.140
2133.00	-37.770	V	-40.411	3.202	10.013	-33.600	-13	-20.600

Test Result (EIRP) = SG Level - Cable Loss + Antenna Gain.

Product	LE910C1-SA		
Test Item	Radiated Spurious Emissions		
Test Mode	Mode 4: LTE Band 14		
Date of Test	2018/12/11	Test Site	CB4-H

Frequency (MHz)	SA Reading (dBm)	Ant.Pol. (H/V)	SG Reading (dBm)	Cable Loss (dB)	Gain (dBi)	EIRP (dBm)	Limit (dBm)	Margin (dB)
LTE_Band14_5M_CH23305_QPSK_1RB0								
1581.00	-59.940	H	-62.574	2.729	8.543	-56.760	-13	-43.760
2371.50	-61.360	H	-63.597	3.367	10.394	-56.570	-13	-43.570
1581.00	-58.700	V	-61.494	2.729	8.543	-55.680	-13	-42.680
2371.50	-55.790	V	-57.797	3.367	10.394	-50.770	-13	-37.770

Test Result (EIRP) = SG Level - Cable Loss + Antenna Gain.

Frequency (MHz)	SA Reading (dBm)	Ant.Pol. (H/V)	SG Reading (dBm)	Cable Loss (dB)	Gain (dBi)	EIRP (dBm)	Limit (dBm)	Margin (dB)
LTE_Band14_5M_CH23330_QPSK_1RB0								
1586.00	-58.910	H	-61.555	2.733	8.558	-55.730	-13	-42.730
2379.00	-58.360	H	-60.594	3.372	10.406	-53.560	-13	-40.560
1586.00	-57.380	V	-60.185	2.733	8.558	-54.360	-13	-41.360
2379.00	-55.860	V	-57.854	3.372	10.406	-50.820	-13	-37.820

Test Result (EIRP) = SG Level - Cable Loss + Antenna Gain.

Frequency (MHz)	SA Reading (dBm)	Ant.Pol. (H/V)	SG Reading (dBm)	Cable Loss (dB)	Gain (dBi)	EIRP (dBm)	Limit (dBm)	Margin (dB)
LTE_Band14_5M_CH23355_QPSK_1RB0								
1591.00	-60.040	H	-62.685	2.738	8.573	-56.850	-13	-43.850
2386.50	-58.820	H	-61.041	3.377	10.418	-54.000	-13	-41.000
1591.00	-60.950	V	-63.755	2.738	8.573	-57.920	-13	-44.920
2386.50	-55.570	V	-57.541	3.377	10.418	-50.500	-13	-37.500

Test Result (EIRP) = SG Level - Cable Loss + Antenna Gain.

Frequency	SA Reading (dBm)	Ant.Pol. (H/V)	SG Reading (dBm)	Cable Loss (dB)	Gain (dBi)	EIRP (dBm)	Limit (dBm)	Margin (dB)
LTE_Band14_10M_CH23330_QPSK_1RB0								
1586.00	-61.460	H	-64.105	2.733	8.558	-58.280	-13	-45.280
2379.00	-61.940	H	-64.174	3.372	10.406	-57.140	-13	-44.140
1586.00	-60.520	V	-63.325	2.733	8.558	-57.500	-13	-44.500
2379.00	-55.910	V	-57.904	3.372	10.406	-50.870	-13	-37.870

Test Result (EIRP) = SG Level - Cable Loss + Antenna Gain.

Product	LE910C1-SA		
Test Item	Radiated Spurious Emissions		
Test Mode	Mode 5: LTE Band 66		
Date of Test	2018/12/11	Test Site	CB4-H

Frequency (MHz)	SA Reading (dBm)	Ant.Pol. (H/V)	SG Reading (dBm)	Cable Loss (dB)	Gain (dBi)	EIRP (dBm)	Limit (dBm)	Margin (dB)
LTE_Band66_1.4M_CH131979_QPSK_1RB0								
3421.40	-55.420	H	-56.691	4.064	12.096	-48.660	-13	-35.660
5132.10	-63.480	H	-61.163	5.075	12.238	-54.000	-13	-41.000
3421.40	-56.390	V	-57.501	4.064	12.096	-49.470	-13	-36.470
5132.10	-57.250	V	-54.773	5.075	12.238	-47.610	-13	-34.610

Test Result (EIRP) = SG Level - Cable Loss + Antenna Gain.

Frequency (MHz)	SA Reading (dBm)	Ant.Pol. (H/V)	SG Reading (dBm)	Cable Loss (dB)	Gain (dBi)	EIRP (dBm)	Limit (dBm)	Margin (dB)
LTE_Band66_1.4M_CH132322_QPSK_1RB0								
3490.00	-57.760	H	-58.969	4.105	12.274	-50.800	-13	-37.800
5235.00	-59.480	H	-57.058	5.105	12.423	-49.740	-13	-36.740
3490.00	-57.760	V	-58.859	4.105	12.274	-50.690	-13	-37.690
5235.00	-56.990	V	-54.398	5.105	12.423	-47.080	-13	-34.080

Test Result (EIRP) = SG Level - Cable Loss + Antenna Gain.

Frequency (MHz)	SA Reading (dBm)	Ant.Pol. (H/V)	SG Reading (dBm)	Cable Loss (dB)	Gain (dBi)	EIRP (dBm)	Limit (dBm)	Margin (dB)
LTE_Band66_1.4M_CH132655_QPSK_1RB0								
3558.60	-64.610	H	-65.643	4.161	12.195	-57.610	-13	-44.610
5337.90	-67.630	H	-65.104	5.134	12.608	-57.630	-13	-44.630
3558.60	-58.570	V	-59.493	4.161	12.195	-51.460	-13	-38.460
5337.90	-60.570	V	-57.874	5.134	12.608	-50.400	-13	-37.400

Test Result (EIRP) = SG Level - Cable Loss + Antenna Gain.

Frequency (MHz)	SA Reading (dBm)	Ant.Pol. (H/V)	SG Reading (dBm)	Cable Loss (dB)	Gain (dBi)	EIRP (dBm)	Limit (dBm)	Margin (dB)
LTE_Band66_20M_CH132072_QPSK_1RB0								
3440.00	-55.470	H	-56.729	4.075	12.144	-48.660	-13	-35.660
5160.00	-64.040	H	-61.695	5.083	12.288	-54.490	-13	-41.490
3440.00	-55.150	V	-56.249	4.075	12.144	-48.180	-13	-35.180
5160.00	-58.350	V	-55.845	5.083	12.288	-48.640	-13	-35.640

Test Result (EIRP) = SG Level - Cable Loss + Antenna Gain.

Frequency (MHz)	SA Reading (dBm)	Ant.Pol. (H/V)	SG Reading (dBm)	Cable Loss (dB)	Gain (dBi)	EIRP (dBm)	Limit (dBm)	Margin (dB)
LTE_Band66_20M_CH132322_QPSK_1RB0								
3490.00	-57.380	H	-58.589	4.105	12.274	-50.420	-13	-37.420
5235.00	-64.560	H	-62.138	5.105	12.423	-54.820	-13	-41.820
3490.00	-57.030	V	-58.129	4.105	12.274	-49.960	-13	-36.960
5235.00	-55.590	V	-52.998	5.105	12.423	-45.680	-13	-32.680

Test Result (EIRP) = SG Level - Cable Loss + Antenna Gain.

Frequency (MHz)	SA Reading (dBm)	Ant.Pol. (H/V)	SG Reading (dBm)	Cable Loss (dB)	Gain (dBi)	EIRP (dBm)	Limit (dBm)	Margin (dB)
LTE_Band66_20M_CH132572_QPSK_1RB0								
3540.00	-62.330	H	-63.413	4.145	12.228	-55.330	-13	-42.330
5310.00	-65.320	H	-62.822	5.126	12.558	-55.390	-13	-42.390
3540.00	-62.630	V	-63.603	4.145	12.228	-55.520	-13	-42.520
5310.00	-54.520	V	-51.852	5.126	12.558	-44.420	-13	-31.420

Test Result (EIRP) = SG Level - Cable Loss + Antenna Gain.