



FCC 47 CFR PART 15 SUBPART B

Product Type : 2G/3.5G Module
Applicant : Telit Communications S.p.A.
Address : Via Stazione di Prosecco, 5/B, Sgonico, TS 34010, Italy
Trade Name : Telit
Model Number : HE910-NAG
FCC ID : RI7HE910NA
IC ID : 5131A-HE910NA
Test Specification : FCC 47 CFR PART 15 SUBPART B: Oct., 2011
ANSI C63.4: 2009
CISPR 22: 1997
ICES-003: Issue 4
Receive Date : Apr. 11, 2012
Issue Date : Apr. 13, 2012

Issue by

A Test Lab Techno Corp.
No. 140-1, Changan Street, Bade City,
Taoyuan County 334, Taiwan R.O.C.
Tel : +886-3-2710188 / Fax : +886-3-2710190



Taiwan Accreditation Foundation accreditation number: 1330

Note: This report shall not be reproduced except in full, without the written approval of A Test Lab Techno Corp. This document may be altered or revised by A Test Lab Techno Corp. personnel only, and shall be noted in the revision section of the document. The client should not use it to claim product endorsement by TAF, or any government agencies. The test results in the report only apply to the tested sample.

Revision History

Rev.	Issue Date	Revisions	Revised By
00	Apr. 13, 2012	Initial Issue	

Verification of Compliance

Issued Date: 04/13/2012

Product Type : 2G/3.5G Module
Applicant : Telit Communications S.p.A.
Address : Via Stazione di Prosecco, 5/B, Sgonico, TS 34010, Italy
Trade Name : Telit
Model Number : HE910-NAG
FCC ID : RI7HE910NA
IC ID : 5131A-HE910NA
EUT Rated Voltage : DC 3.8V
Test Voltage : DC 3.8V
Applicable : FCC 47 CFR PART 15 SUBPART B: Oct., 2011
Standard : ANSI C63.4: 2009
CISPR 22: 1997
ICES-003: Issue 4

Test Result : Complied

Performing Lab. : A Test Lab Techno Corp.

No. 140-1, Changan Street, Bade City,
Taoyuan County 334, Taiwan R.O.C.

Tel : +886-3-2710188 / Fax : +886-3-2710190

Taiwan Accreditation Foundation accreditation number: 1330

<http://www.atl-lab.com.tw/e-index.htm>



The above equipment has been tested by A Test Lab Techno Corp., and found compliance with the requirements set forth in the technical standards mentioned above. The results of testing in this report apply only to the product/system, which was tested. Other similar equipment will not necessarily produce the same results due to production tolerance and measurement uncertainties.

Approved By



(Manager)

(Murphy Wang)

Reviewed By

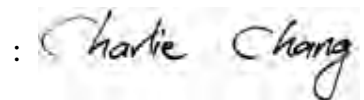

(Testing Engineer)

(Charlie Chang)

TABLE OF CONTENTS

1	General Information	5
2	EUT Description.....	6
3	Test Methodology.....	7
	3.1. Decision of Test Mode	7
	3.2. EUT Exercise Software	7
	3.3. Configuration of Test System Details.....	8
	3.4. Test Site Environment.....	8
4	Emission Test	9
	4.1. Conducted Emission Measurement.....	9
	4.2. Radiated Interference Measurement	21

1 General Information

1.1 Summary of Test Result

Emission			
Standard	Item	Result	Remark
FCC 47 CFR PART 15 SUBPART B: Oct., 2011 ANSI C63.4: 2009 ICES-003: Issue 4	15.107: Conducted Emission	PASS	Meet Class B limit
FCC 47 CFR PART 15 SUBPART B: Oct., 2011 ANSI C63.4: 2009 ICES-003: Issue 4	15.109: Radiated Emission	PASS	Meet Class B limit

The test results of this report relate only to the tested sample(s) identified in this report. Manufacturer or whom it may concern should recognize the pass or fail of the test result.

1.2 Measurement Uncertainty

Conducted Emission

The measurement uncertainty is evaluated as ± 2.24 dB.

Conducted Emissions (Telecommunication Ports)

The measurement uncertainty is evaluated as ± 2.24 dB.

Radiated Emission

The measurement uncertainty of 30 MHz - 1GHz is evaluated as ± 3.072 dB.

The measurement uncertainty of 1GHz - 40GHz is evaluated as ± 3.072 dB.

2 EUT Description

Product	:	2G/3.5G Module
Trade Name	:	Telit
Model Number	:	HE910-NAG
FCC ID	:	RI7HE910NA
IC ID	:	5131A-HE910NA
Applicant	:	Telit Communications S.p.A. Via Stazione di Prosecco, 5/B, Sgonico, TS 34010, Italy
Manufacturer	:	Telit Communications S.p.A. Via Stazione di Prosecco, 5/B, Sgonico, TS 34010, Italy

I/O Port Description :

I/O Port Types	Q'TY	Test Description
1). Signal Port	2	Connected to Antenna
2). RS-232 Port	1	Connected to Notebook
3). DC Power Port	1	Connected to DC Power source

3 Test Methodology

3.1. Decision of Test Mode

3.1.1 The following test mode(s) were scanned during the preliminary test:

Pre-Test Mode
Mode 1: GPRS 850 + GPS Link Mode
Mode 2: GPRS 1900 + GPS Link Mode
Mode 3: WCDMA Band II + GPS Link Mode
Mode 4: WCDMA Band IV + GPS Link Mode
Mode 5: WCDMA Band V+ GPS Link Mode

3.1.2 After the preliminary scan, the following test mode was found to produce the highest emission level.

Final Test Mode			
Emission	Conducted Emission		Mode 1 / Mode 2 / Mode 3 / Mode 4 / Mode 5
	Radiated Emission	Below 1GHz	Mode 1 / Mode 2 / Mode 3 / Mode 4 / Mode 5
		Above 1GHz	Mode 1 / Mode 2 / Mode 3 / Mode 4 / Mode 5

Then, the above highest emission mode of the configuration of the EUT and cable was chosen for all final test items.

3.2. EUT Exercise Software

1. Setup the EUT and simulators as shown on 3.3.
2. Turn on the power of all equipment.
3. EUT link to CMU200.
4. Turn on EUT's GPS function and Link Signal Generator.
5. The EUT will start to operate function.

3.3. Configuration of Test System Details

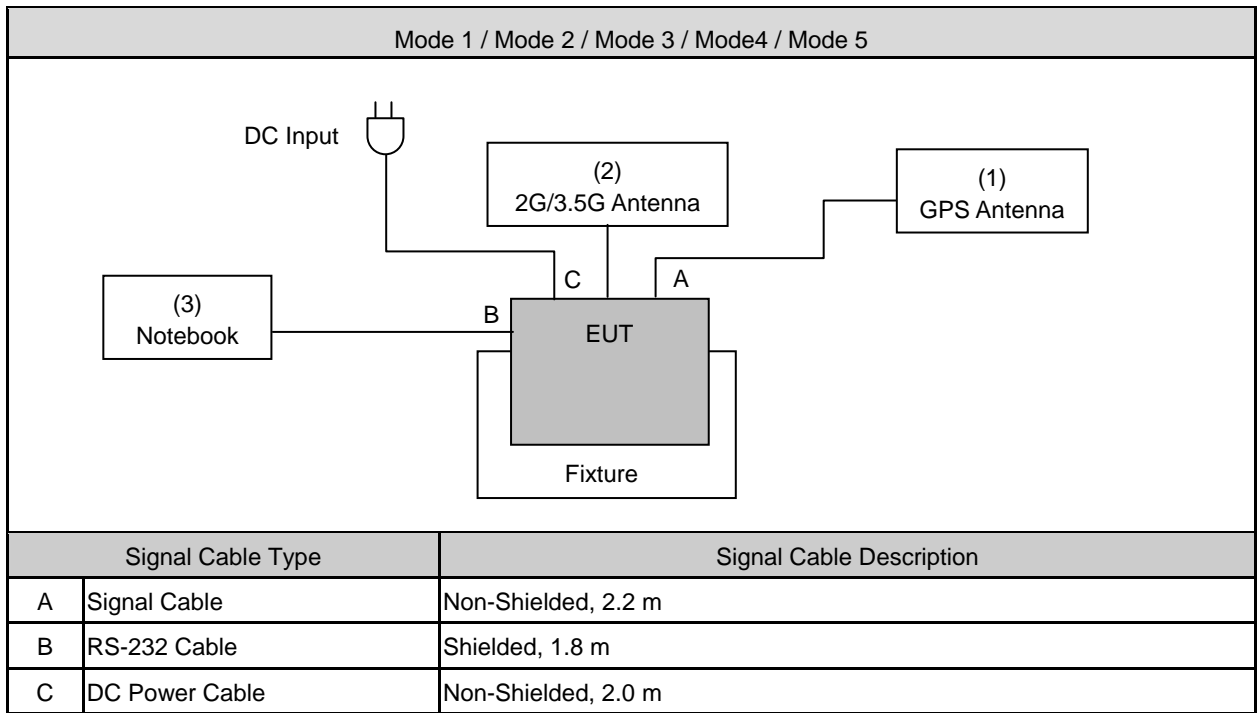

Devices Description				
Product	Manufacturer	Model Number	Serial Number	Power Cord
1. GPS Antenna	Tel Cab	T-AT311	N/A	N/A
2. 2G/3.5G Antenna	Tel Cab	T-AT314	N/A	N/A
3. Notebook	DELL	D531	CN-OXM006-48643 -87A-3398	Non-Shielded, 2.0 m

3.4. Test Site Environment

Items	Test Item	Required (IEC 68-1)	Actual
Temperature (°C)	FCC part 15: 15.107 Conducted Emission	15-35	26
Humidity (%RH)		25-75	60
Barometric pressure (mbar)		860-1060	950
Temperature (°C)	FCC part 15: 15.109 Radiated Emission	15-35	26
Humidity (%RH)		25-75	60
Barometric pressure (mbar)		860-1060	950

4 Emission Test

4.1. Conducted Emission Measurement

4.1.1. Limit

A.C. Mains Conducted Interference Limit :

Frequency (MHz)	Class A (dBuV)		Class B (dBuV)	
	Quasi-peak	Average	Quasi-peak	Average
0.15 - 0.5	79	66	66 - 56	56 - 46
0.50 - 5.0	73	60	56	46
5.0 - 30.0	73	60	60	50

NOTE: (1) The lower limit shall apply at the transition frequencies.

(2) The limit decreases in line with the logarithm of the frequency in the range 0.15 to 0.50 MHz.

4.1.2. Test Instruments

Description	Manufacturer	Model Number	Serial Number	Cal. Date	Remark
Test Receiver	R&S	ESCI	100367	06/30/2011	(1)
LISN	R&S	ENV216	101040	03/07/2012	(1)
LISN	R&S	ENV216	101041	03/07/2012	(1)
Test Site	ATL	TE02	TE02	N.C.R.	-----

Remark: (1) Calibration period 1 year. (2) Calibration period 2 years.

NOTE: N.C.R. = No Calibration Request.

4.1.3. Test Setup

A.C. mains setup

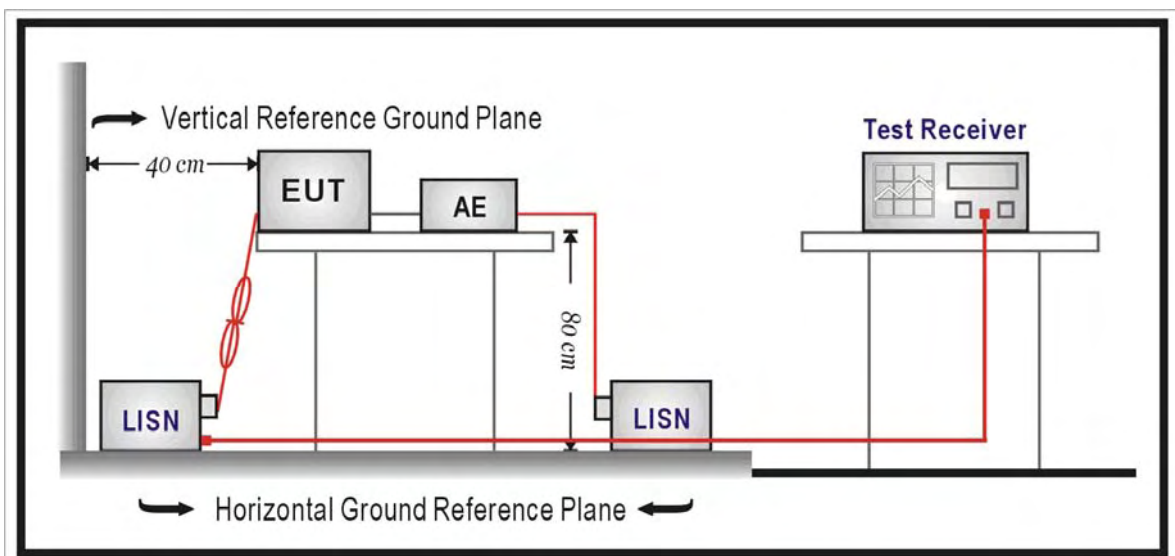

4.1.4. Test Procedure

The EUT and simulators are connected to the main power through a line impedance stabilization network (L.I.S.N.). This provides a 50 ohm /50uH coupling impedance for the measuring equipment. The peripheral devices are also connected to the main power through a LISN that provides a 50ohm/50uH coupling impedance with 50ohm termination.

For A.C. mains conducted interference, measured both sides of A.C. lines and carried out using quasi-peak and average detector receivers of maximum conducted interference.

Conducted emissions were investigated over the frequency range from 0.15 MHz to 30 MHz using a receiver bandwidth of 9 kHz. The equipment under test (EUT) shall be meet the limits in section 4.1.1, as applicable, including the average limit and the quasi-peak limit when using respectively, an average detector and quasi-peak detector measured in accordance with the methods described of related standard. The voltage limits shall be met. If the average limit is met when using a quasi-peak detector receiver, the EUT shall be deemed to meet both limits and measurement with the average detector receiver is unnecessary.

If the reading of the measuring receiver shows fluctuations close to the limit, the reading shall be observed for at least 15 s at each measurement frequency; the higher reading shall be recorded with the exception of any brief isolated high reading which shall be ignored.

4.1.5. Test Result

Standard:	FCC Part 15B Class B	Line:	+
Test item:	Conducted Emission	Power:	DC 3.8V
Model Number:	HE910-NAG	Temp.(°C)/Hum.(%RH):	26(°C)/60%RH
Mode:	1	Date:	04/13/2012
		Test By:	Charlie Chang
Description:			

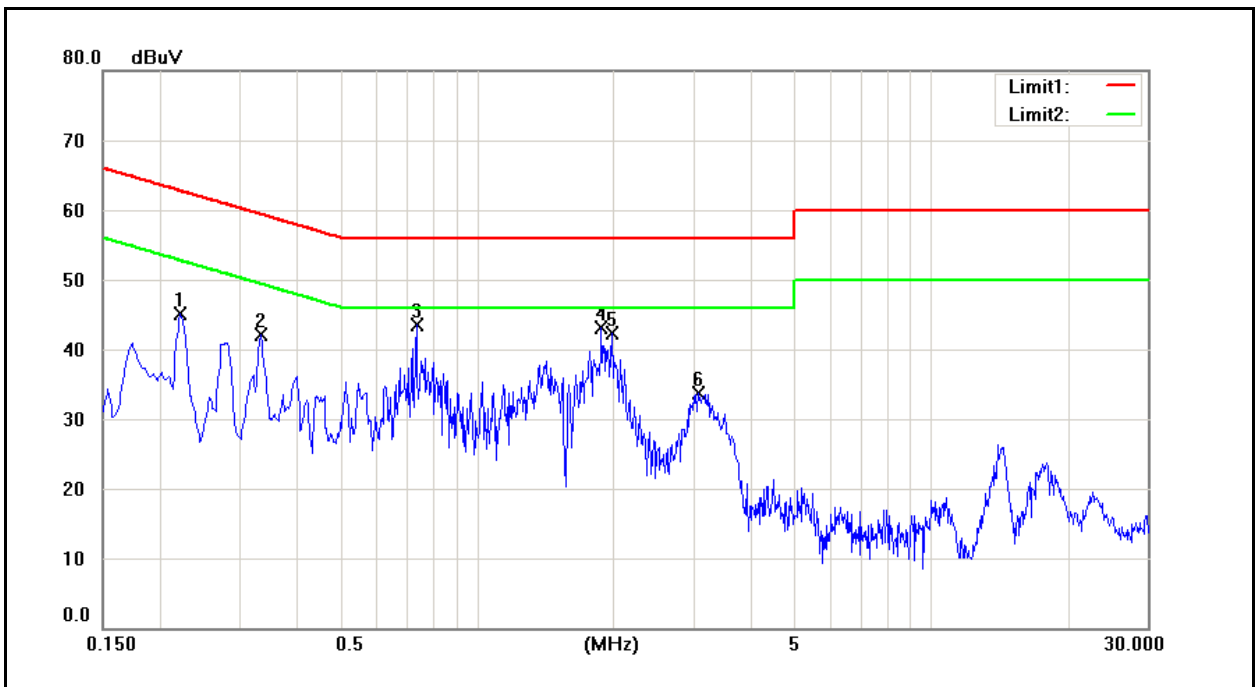

No.	Frequency (MHz)	QP reading (dBuV)	AVG reading (dBuV)	Correction factor (dB)	QP result (dBuV)	AVG result (dBuV)	QP limit (dBuV)	AVG limit (dBuV)	QP margin (dB)	AVG margin (dB)	Remark
1	0.2220	44.08	43.58	0.27	44.35	43.85	62.74	52.74	-18.39	-8.89	Pass
2	0.3340	40.51	39.15	0.21	40.72	39.36	59.35	49.35	-18.63	-9.99	Pass
3	0.7380	39.89	32.74	0.17	40.06	32.91	56.00	46.00	-15.94	-13.09	Pass
4	1.8820	33.40	28.04	0.22	33.62	28.26	56.00	46.00	-22.38	-17.74	Pass
5	1.9900	37.59	28.41	0.22	37.81	28.63	56.00	46.00	-18.19	-17.37	Pass
6	3.0780	31.25	23.34	0.24	31.49	23.58	56.00	46.00	-24.51	-22.42	Pass

Standard:	FCC Part 15B Class B	Line:	-
Test item:	Conducted Emission	Power:	DC 3.8V
Model Number:	HE910-NAG	Temp.(°C)/Hum.(%RH):	26(°C)/60%RH
Mode:	1	Date:	04/13/2012
		Test By:	Charlie Chang
Description:			

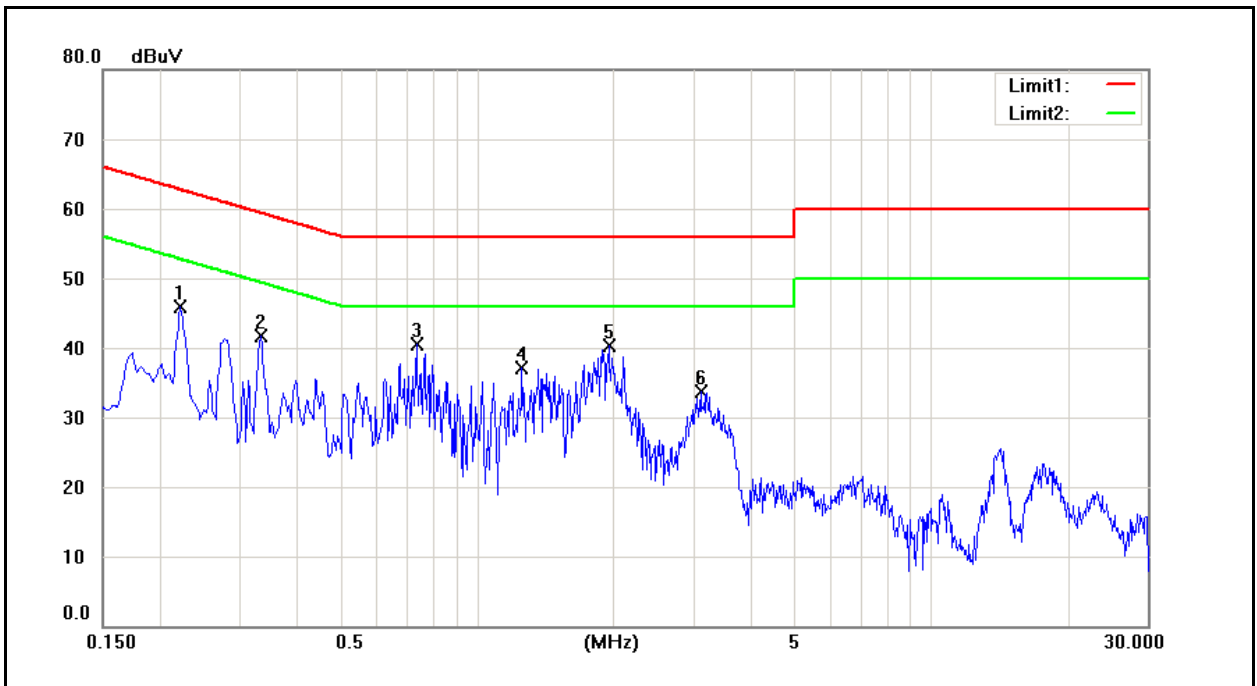

No.	Frequency (MHz)	QP reading (dBuV)	AVG reading (dBuV)	Correction factor (dB)	QP result (dBuV)	AVG result (dBuV)	QP limit (dBuV)	AVG limit (dBuV)	QP margin (dB)	AVG margin (dB)	Remark
1	0.2220	44.01	43.46	0.27	44.28	43.73	62.74	52.74	-18.46	-9.01	Pass
2	0.3340	40.36	39.06	0.21	40.57	39.27	59.35	49.35	-18.78	-10.08	Pass
3	0.7380	39.00	33.26	0.17	39.17	33.43	56.00	46.00	-16.83	-12.57	Pass
4	1.2620	31.94	25.41	0.20	32.14	25.61	56.00	46.00	-23.86	-20.39	Pass
5	1.9500	30.34	24.55	0.22	30.56	24.77	56.00	46.00	-25.44	-21.23	Pass
6	3.1100	30.35	23.08	0.24	30.59	23.32	56.00	46.00	-25.41	-22.68	Pass

Standard:	FCC Part 15B Class B	Line:	+
Test item:	Conducted Emission	Power:	DC 3.8V
Model Number:	HE910-NAG	Temp.(°C)/Hum.(%RH):	26(°C)/60%RH
Mode:	2	Date:	04/13/2012
		Test By:	Charlie Chang
Description:			

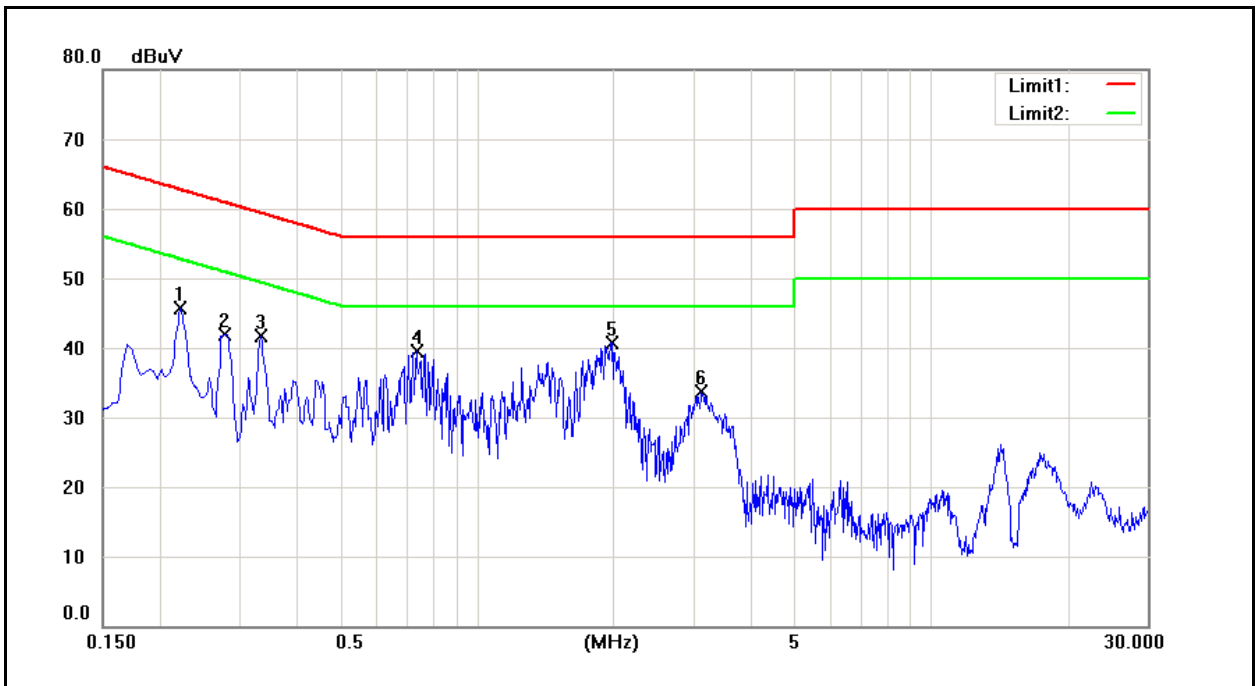

No.	Frequency (MHz)	QP reading (dBuV)	AVG reading (dBuV)	Correction factor (dB)	QP result (dBuV)	AVG result (dBuV)	QP limit (dBuV)	AVG limit (dBuV)	QP margin (dB)	AVG margin (dB)	Remark
1	0.2220	43.74	43.26	0.27	44.01	43.53	62.74	52.74	-18.73	-9.21	Pass
2	0.2780	37.17	35.43	0.24	37.41	35.67	60.88	50.88	-23.47	-15.21	Pass
3	0.3340	40.39	38.88	0.21	40.60	39.09	59.35	49.35	-18.75	-10.26	Pass
4	0.7380	39.56	33.12	0.17	39.73	33.29	56.00	46.00	-16.27	-12.71	Pass
5	1.9860	37.24	27.19	0.22	37.46	27.41	56.00	46.00	-18.54	-18.59	Pass
6	3.1260	30.69	23.54	0.24	30.93	23.78	56.00	46.00	-25.07	-22.22	Pass

Standard:	FCC Part 15B Class B	Line:	-
Test item:	Conducted Emission	Power:	DC 3.8V
Model Number:	HE910-NAG	Temp.(°C)/Hum.(%RH):	26(°C)/60%RH
Mode:	2	Date:	04/13/2012
		Test By:	Charlie Chang
Description:			

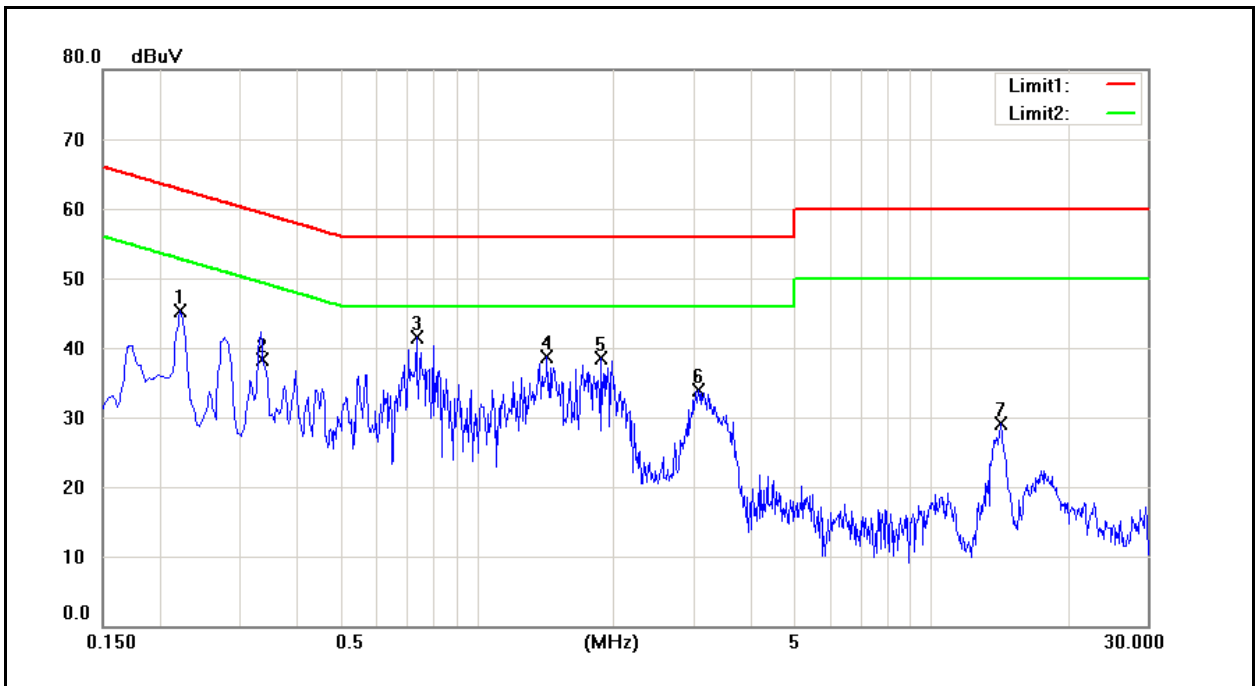

No.	Frequency (MHz)	QP reading (dBuV)	AVG reading (dBuV)	Correction factor (dB)	QP result (dBuV)	AVG result (dBuV)	QP limit (dBuV)	AVG limit (dBuV)	QP margin (dB)	AVG margin (dB)	Remark
1	0.2220	43.67	43.22	0.27	43.94	43.49	62.74	52.74	-18.80	-9.25	Pass
2	0.3400	40.20	38.85	0.20	40.40	39.05	59.20	49.20	-18.80	-10.15	Pass
3	0.7380	39.48	33.04	0.17	39.65	33.21	56.00	46.00	-16.35	-12.79	Pass
4	1.4280	35.27	28.63	0.20	35.47	28.83	56.00	46.00	-20.53	-17.17	Pass
5	1.8820	32.32	27.90	0.22	32.54	28.12	56.00	46.00	-23.46	-17.88	Pass
6	3.0780	30.49	23.37	0.24	30.73	23.61	56.00	46.00	-25.27	-22.39	Pass
7	14.2820	21.65	11.25	0.27	21.92	11.52	60.00	50.00	-38.08	-38.48	Pass

Standard:	FCC Part 15B Class B	Line:	+
Test item:	Conducted Emission	Power:	DC 3.8V
Model Number:	HE910-NAG	Temp.(°C)/Hum.(%RH):	26(°C)/60%RH
Mode:	3	Date:	04/13/2012
		Test By:	Charlie Chang
Description:			

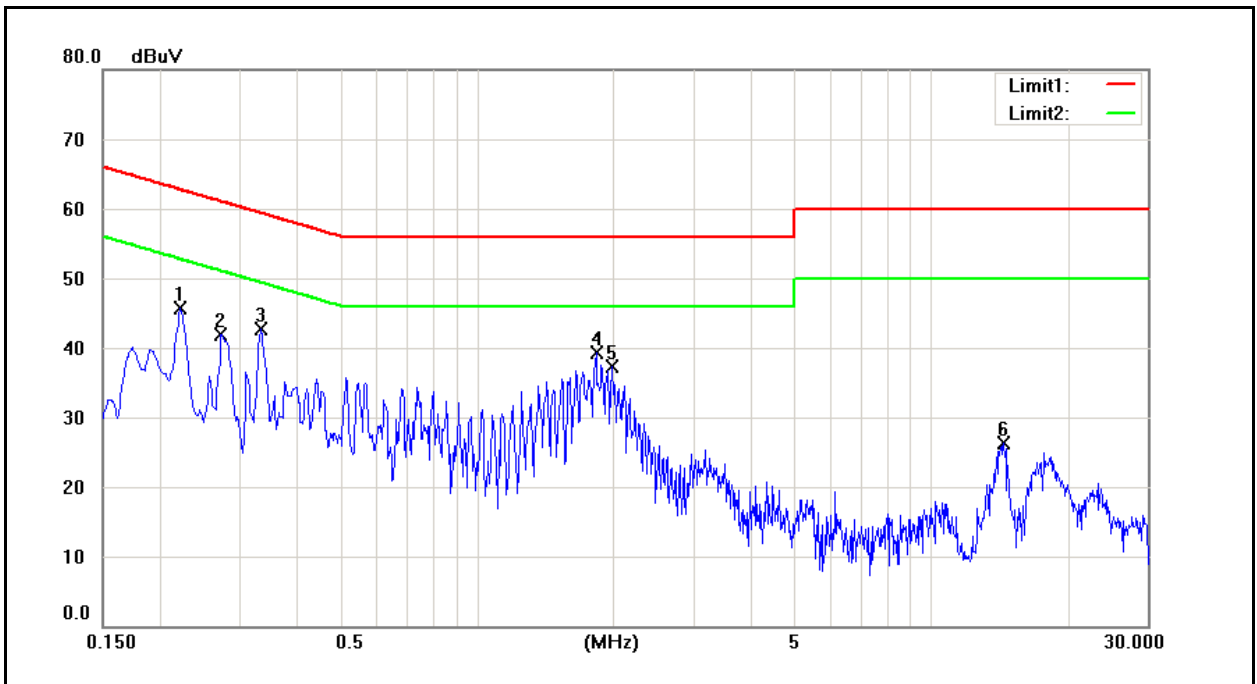

No.	Frequency (MHz)	QP reading (dBuV)	AVG reading (dBuV)	Correction factor (dB)	QP result (dBuV)	AVG result (dBuV)	QP limit (dBuV)	AVG limit (dBuV)	QP margin (dB)	AVG margin (dB)	Remark
1	0.2220	44.95	44.27	0.27	45.22	44.54	62.74	52.74	-17.52	-8.20	Pass
2	0.2740	40.04	39.22	0.24	40.28	39.46	61.00	51.00	-20.72	-11.54	Pass
3	0.3340	41.21	39.85	0.21	41.42	40.06	59.35	49.35	-17.93	-9.29	Pass
4	1.8300	33.88	29.35	0.21	34.09	29.56	56.00	46.00	-21.91	-16.44	Pass
5	1.9820	30.81	21.28	0.22	31.03	21.50	56.00	46.00	-24.97	-24.50	Pass
6	14.4660	24.35	12.86	0.29	24.64	13.15	60.00	50.00	-35.36	-36.85	Pass

Standard:	FCC Part 15B Class B	Line:	-
Test item:	Conducted Emission	Power:	DC 3.8V
Model Number:	HE910-NAG	Temp.(°C)/Hum.(%RH):	26(°C)/60%RH
Mode:	3	Date:	04/13/2012
		Test By:	Charlie Chang
Description:			

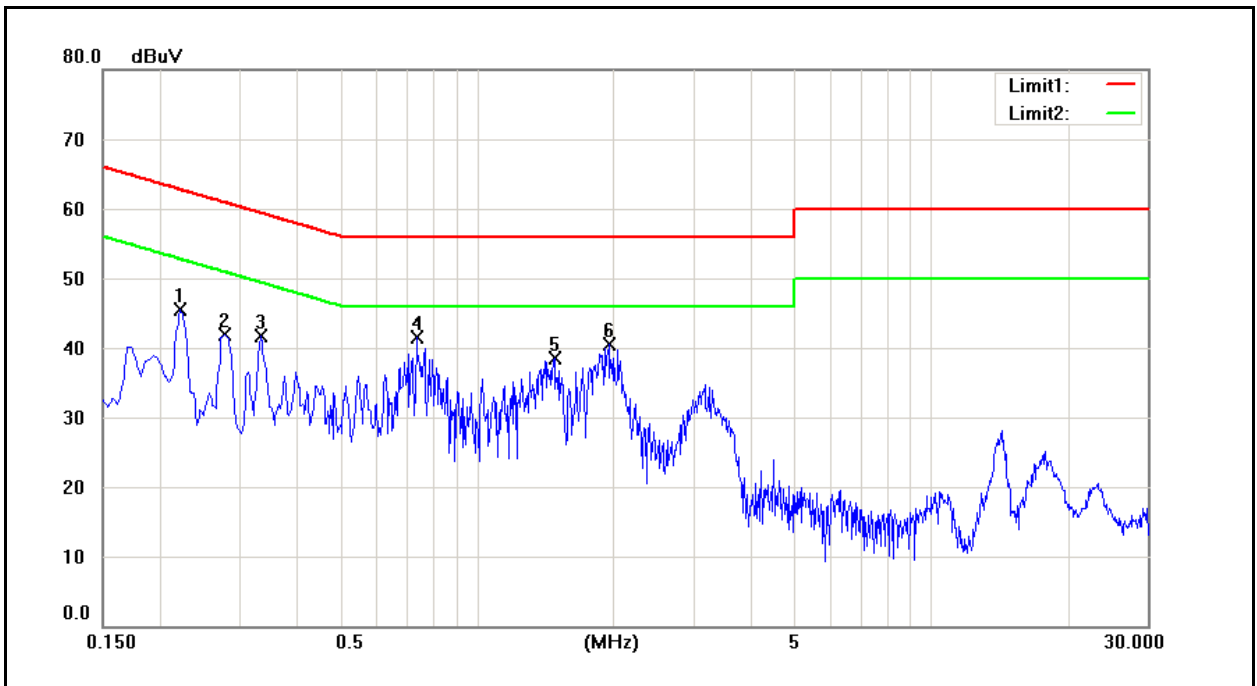

No.	Frequency (MHz)	QP reading (dBuV)	AVG reading (dBuV)	Correction factor (dB)	QP result (dBuV)	AVG result (dBuV)	QP limit (dBuV)	AVG limit (dBuV)	QP margin (dB)	AVG margin (dB)	Remark
1	0.2220	44.12	43.64	0.27	44.39	43.91	62.74	52.74	-18.35	-8.83	Pass
2	0.2780	37.41	35.66	0.24	37.65	35.90	60.88	50.88	-23.23	-14.98	Pass
3	0.3340	40.71	39.20	0.21	40.92	39.41	59.35	49.35	-18.43	-9.94	Pass
4	0.7380	39.29	31.82	0.17	39.46	31.99	56.00	46.00	-16.54	-14.01	Pass
5	1.4860	35.55	29.84	0.20	35.75	30.04	56.00	46.00	-20.25	-15.96	Pass
6	1.9580	34.90	27.74	0.22	35.12	27.96	56.00	46.00	-20.88	-18.04	Pass

Standard:	FCC Part 15B Class B	Line:	+
Test item:	Conducted Emission	Power:	DC 3.8V
Model Number:	HE910-NAG	Temp.(°C)/Hum.(%RH):	26(°C)/60%RH
Mode:	4	Date:	04/13/2012
		Test By:	Charlie Chang
Description:			

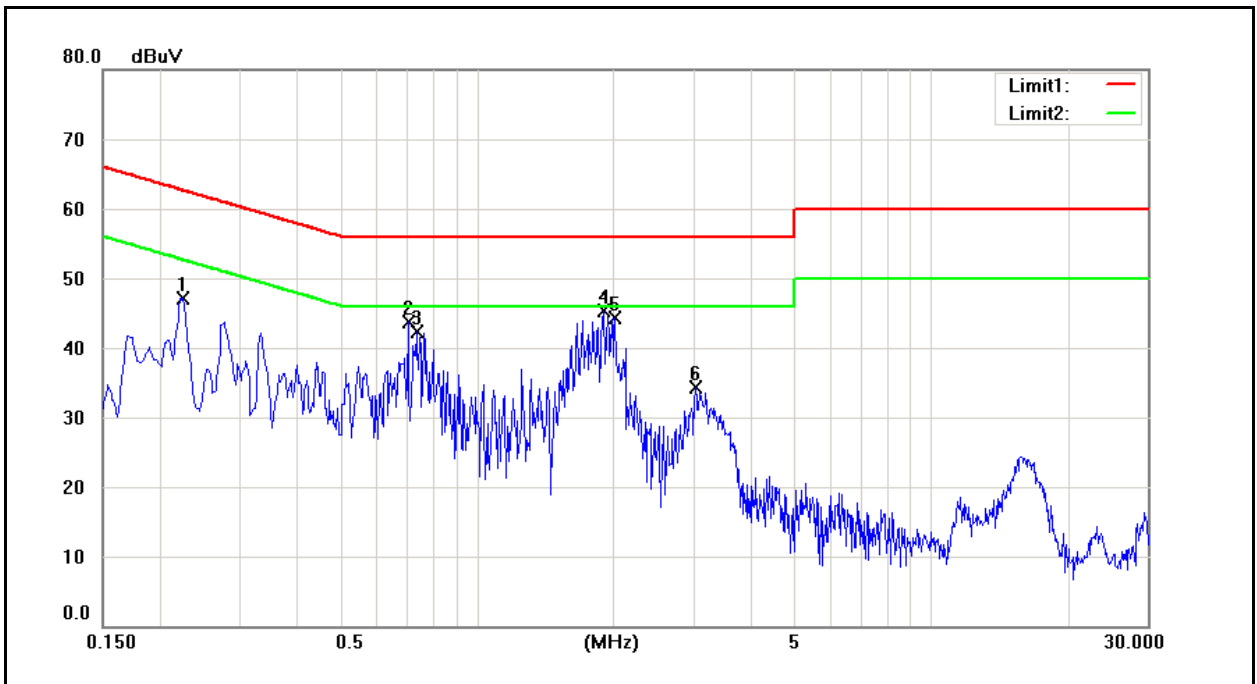

No.	Frequency (MHz)	QP reading (dBuV)	AVG reading (dBuV)	Correction factor (dB)	QP result (dBuV)	AVG result (dBuV)	QP limit (dBuV)	AVG limit (dBuV)	QP margin (dB)	AVG margin (dB)	Remark
1	0.2260	41.42	40.46	0.27	41.69	40.73	62.60	52.60	-20.91	-11.87	Pass
2	0.7060	38.78	33.21	0.17	38.95	33.38	56.00	46.00	-17.05	-12.62	Pass
3	0.7380	40.33	33.88	0.17	40.50	34.05	56.00	46.00	-15.50	-11.95	Pass
4	1.8980	41.88	31.80	0.22	42.10	32.02	56.00	46.00	-13.90	-13.98	Pass
5	2.0180	32.81	25.74	0.22	33.03	25.96	56.00	46.00	-22.97	-20.04	Pass
6	3.0340	30.98	23.97	0.24	31.22	24.21	56.00	46.00	-24.78	-21.79	Pass

Standard:	FCC Part 15B Class B	Line:	-
Test item:	Conducted Emission	Power:	DC 3.8V
Model Number:	HE910-NAG	Temp.(°C)/Hum.(%RH):	26(°C)/60%RH
Mode:	4	Date:	04/13/2012
		Test By:	Charlie Chang
Description:			

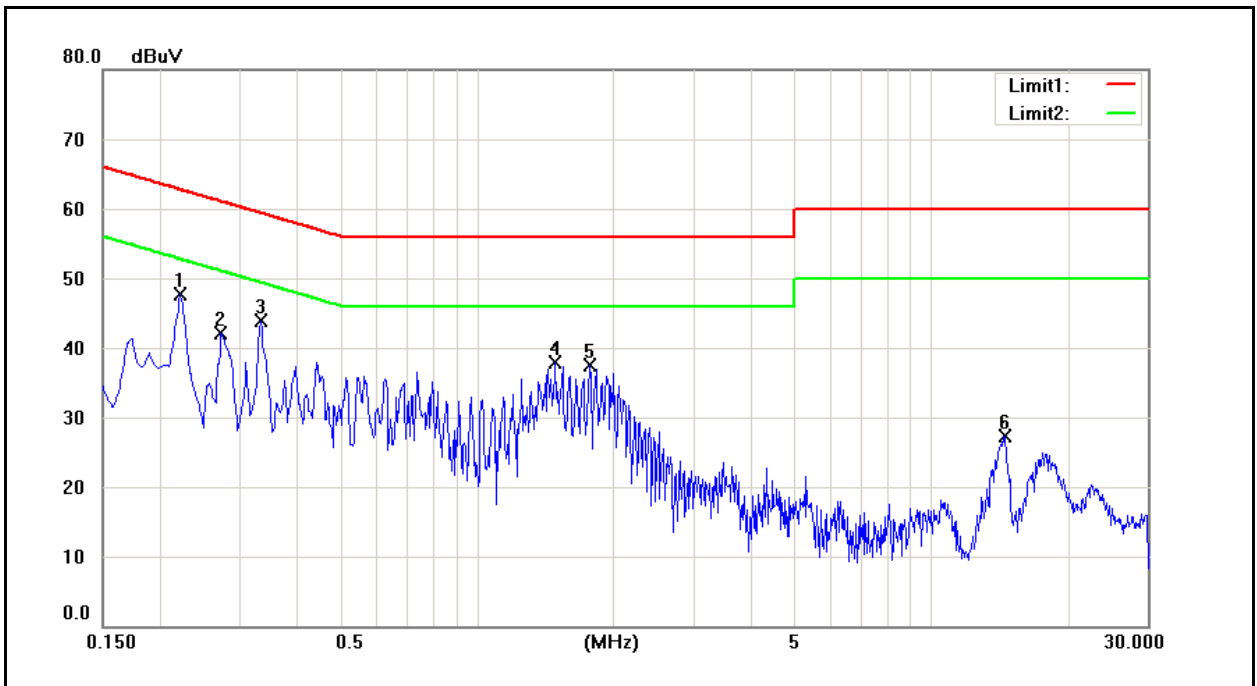

No.	Frequency (MHz)	QP reading (dBuV)	AVG reading (dBuV)	Correction factor (dB)	QP result (dBuV)	AVG result (dBuV)	QP limit (dBuV)	AVG limit (dBuV)	QP margin (dB)	AVG margin (dB)	Remark
1	0.2220	45.65	45.11	0.27	45.92	45.38	62.74	52.74	-16.82	-7.36	Pass
2	0.2740	40.95	40.11	0.24	41.19	40.35	61.00	51.00	-19.81	-10.65	Pass
3	0.3340	42.11	40.77	0.21	42.32	40.98	59.35	49.35	-17.03	-8.37	Pass
4	1.4900	33.93	29.74	0.20	34.13	29.94	56.00	46.00	-21.87	-16.06	Pass
5	1.7740	36.09	31.53	0.21	36.30	31.74	56.00	46.00	-19.70	-14.26	Pass
6	14.5300	24.20	13.59	0.29	24.49	13.88	60.00	50.00	-35.51	-36.12	Pass

Standard:	FCC Part 15B Class B	Line:	+
Test item:	Conducted Emission	Power:	DC 3.8V
Model Number:	HE910-NAG	Temp.(°C)/Hum.(%RH):	26(°C)/60%RH
Mode:	5	Date:	04/13/2012
		Test By:	Charlie Chang
Description:			

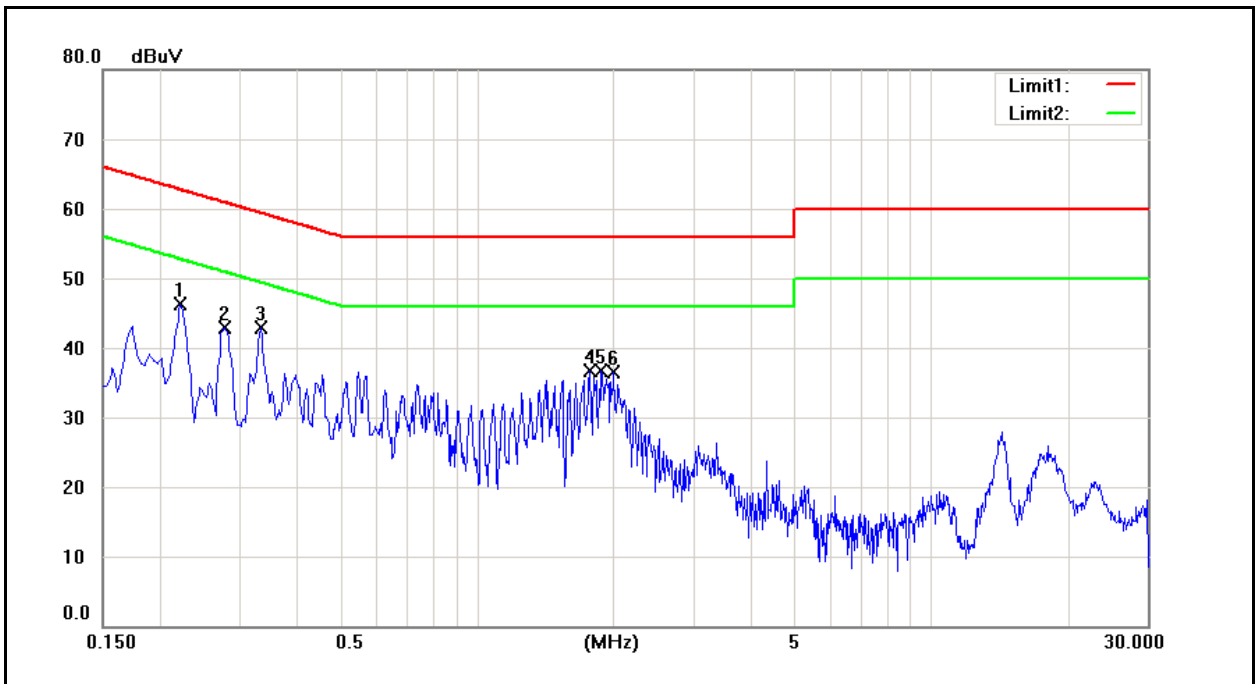

No.	Frequency (MHz)	QP reading (dBuV)	AVG reading (dBuV)	Correction factor (dB)	QP result (dBuV)	AVG result (dBuV)	QP limit (dBuV)	AVG limit (dBuV)	QP margin (dB)	AVG margin (dB)	Remark
1	0.2220	44.81	44.34	0.27	45.08	44.61	62.74	52.74	-17.66	-8.13	Pass
2	0.2780	37.40	35.46	0.24	37.64	35.70	60.88	50.88	-23.24	-15.18	Pass
3	0.3340	41.41	39.95	0.21	41.62	40.16	59.35	49.35	-17.73	-9.19	Pass
4	1.7740	33.85	29.13	0.21	34.06	29.34	56.00	46.00	-21.94	-16.66	Pass
5	1.8820	33.88	27.66	0.22	34.10	27.88	56.00	46.00	-21.90	-18.12	Pass
6	2.0060	31.55	25.15	0.22	31.77	25.37	56.00	46.00	-24.23	-20.63	Pass

Standard:	FCC Part 15B Class B	Line:	-
Test item:	Conducted Emission	Power:	DC 3.8V
Model Number:	HE910-NAG	Temp.(°C)/Hum.(%RH):	26(°C)/60%RH
Mode:	5	Date:	04/13/2012
		Test By:	Charlie Chang
Description:			

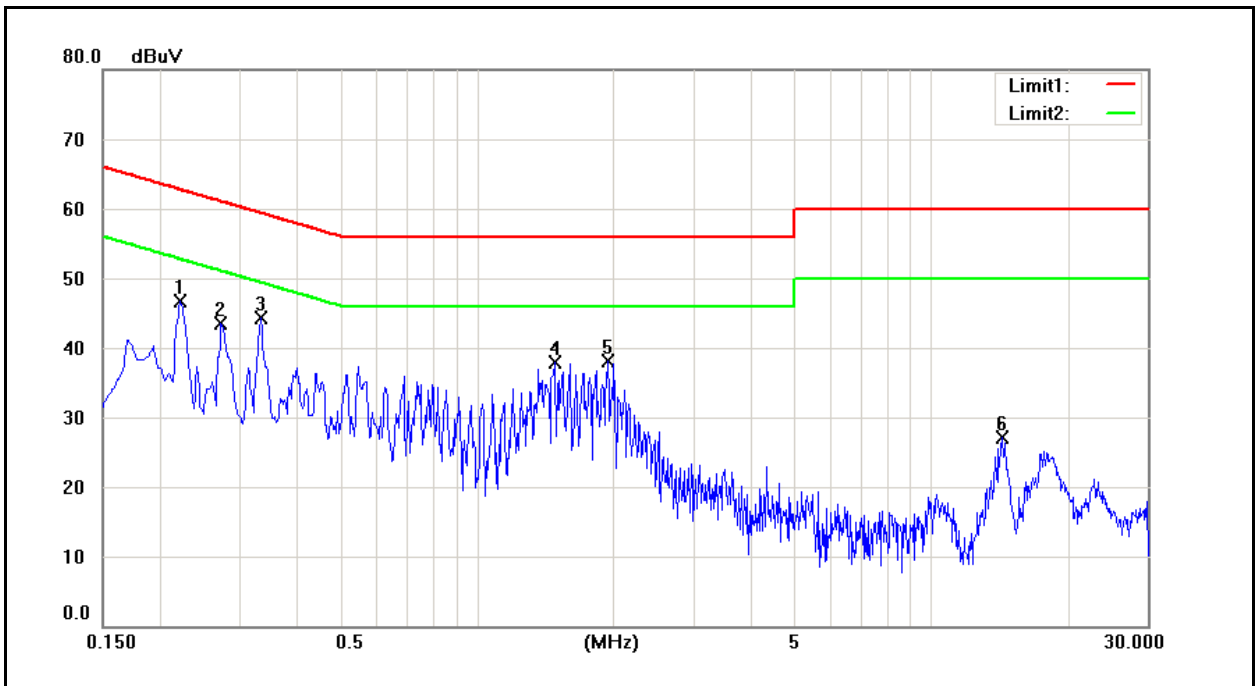

No.	Frequency (MHz)	QP reading (dBuV)	AVG reading (dBuV)	Correction factor (dB)	QP result (dBuV)	AVG result (dBuV)	QP limit (dBuV)	AVG limit (dBuV)	QP margin (dB)	AVG margin (dB)	Remark
1	0.2220	45.59	45.11	0.27	45.86	45.38	62.74	52.74	-16.88	-7.36	Pass
2	0.2740	41.46	40.64	0.24	41.70	40.88	61.00	51.00	-19.30	-10.12	Pass
3	0.3340	42.27	40.80	0.21	42.48	41.01	59.35	49.35	-16.87	-8.34	Pass
4	1.4860	34.87	29.95	0.20	35.07	30.15	56.00	46.00	-20.93	-15.85	Pass
5	1.9420	35.08	29.21	0.22	35.30	29.43	56.00	46.00	-20.70	-16.57	Pass
6	14.4140	24.55	12.49	0.30	24.85	12.79	60.00	50.00	-35.15	-37.21	Pass

4.2. Radiated Interference Measurement

4.2.1. Limit

Under 1GHz test shall not exceed following value:

FCC 47 CFR PART 15 SUBPART B				
Frequency range (MHz)	Class A		Class B	
	Distance (m)	dBuV/m	Distance (m)	dBuV/m
30 to 88	10	39	3	40
88 to 216	10	43.5	3	43.5
216 to 960	10	46.4	3	46
Above 960	10	49.5	3	54

CISPR 22				
Frequency range (MHz)	Class A		Class B	
	Distance (m)	dBuV/m	Distance (m)	dBuV/m
30 to 230	10	40	10	30
230 to 1000	10	47	10	37

Above 1GHz test shall not exceed following value:

Frequency (MHz)	dBuV/m (Distance 3m)			
	Class A		Class B	
	Average	Peak	Average	Peak
1000 ~ 40000	60	80	54	74

Remark:

1. The tighter limit shall apply at the edge between two frequency bands.
2. Distance refers to the distance in meters between the measuring instrument antenna and the closed point of any part of the device or system.
3. RF Voltage (dBuV/m) = 20 log RF Voltage (uV/m)
4. Peak detector limit is corresponding to 20 dB above the maximum permitted average limit.

4.2.2. Test Instruments

10 Meter Chamber					
Equipment	Manufacturer	Model Number	Serial Number	Cal. Date	Remark
Pre Amplifier	Agilent	8447D	2944A11120	01/10/2012	(1)
Pre Amplifier	Agilent	8447D	2944A11119	01/10/2012	(1)
Test Receiver	R&S	ESCI	100722	10/18/2011	(1)
Test Receiver	R&S	ESCI	101000	12/26/2011	(1)
Broadband Antenna	SCHWARZBECK MESS-ELEKTRONIK	VULB 9160	9160-3268	07/01/2011	(1)
Broadband Antenna	SCHWARZBECK MESS-ELEKTRONIK	VULB 9160	9160-3273	12/27/2011	(1)
Test Site	ATL	TE06	TE06	09/05/2011	(1)

3 Meter Chamber					
Equipment	Manufacturer	Model Number	Serial Number	Cal. Date	Remark
Spectrum Analyzer	Agilent	E4445A	MY46181986	06/16/2011	(1)
Amplifier	Mini-Circuits	ZKL-1R5+	N/A	05/30/2011	(1)
Amplifier	Mini-Circuits	ZVA-213-S+	N/A	05/30/2011	(1)
RF Pre-selector	Agilent	N9039A	MY46520255	05/16/2011	(1)
Horn Antenna (1~18GHz)	ETS-Lindgren	3117	00128055	08/25/2011	(1)
Horn Antenna (18~40GHz)	SCHWARZBECK MESS-ELEKTRONIK	BBHA9170	9170-320	06/28/2011	(1)
Test Site	ATL	TE09	TE09	05/13/2011	(1)

Remark: ⁽¹⁾ Calibration period 1 year. ⁽²⁾ Calibration period 2 years.

NOTE: N.C.R. = No Calibration Request.

4.2.3. Setup

Below 1GHz

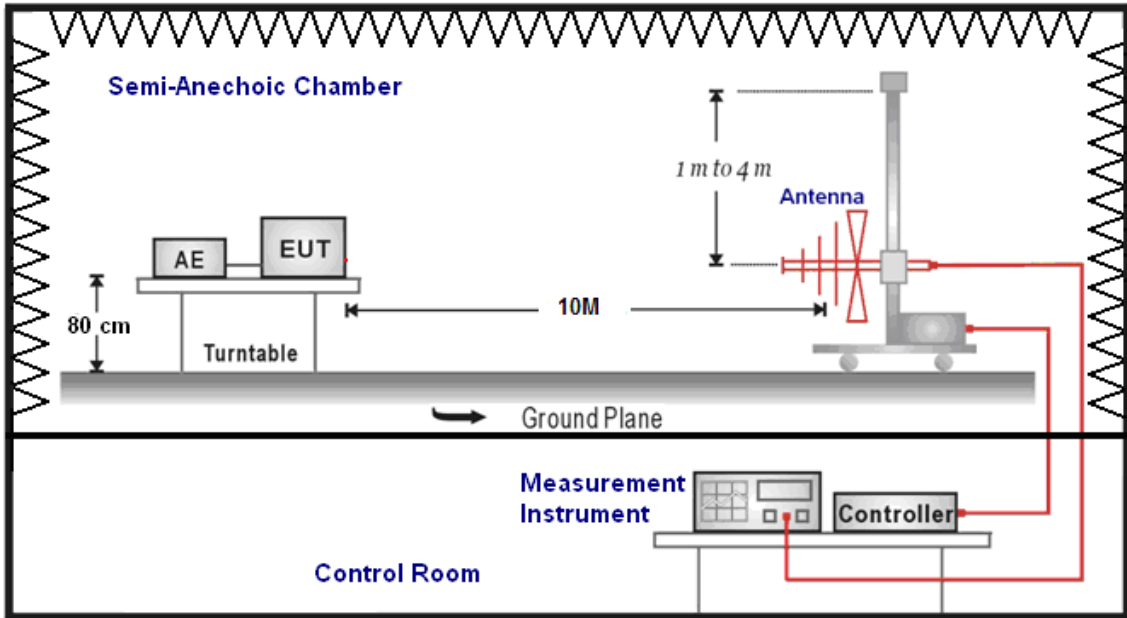

Above 1GHz

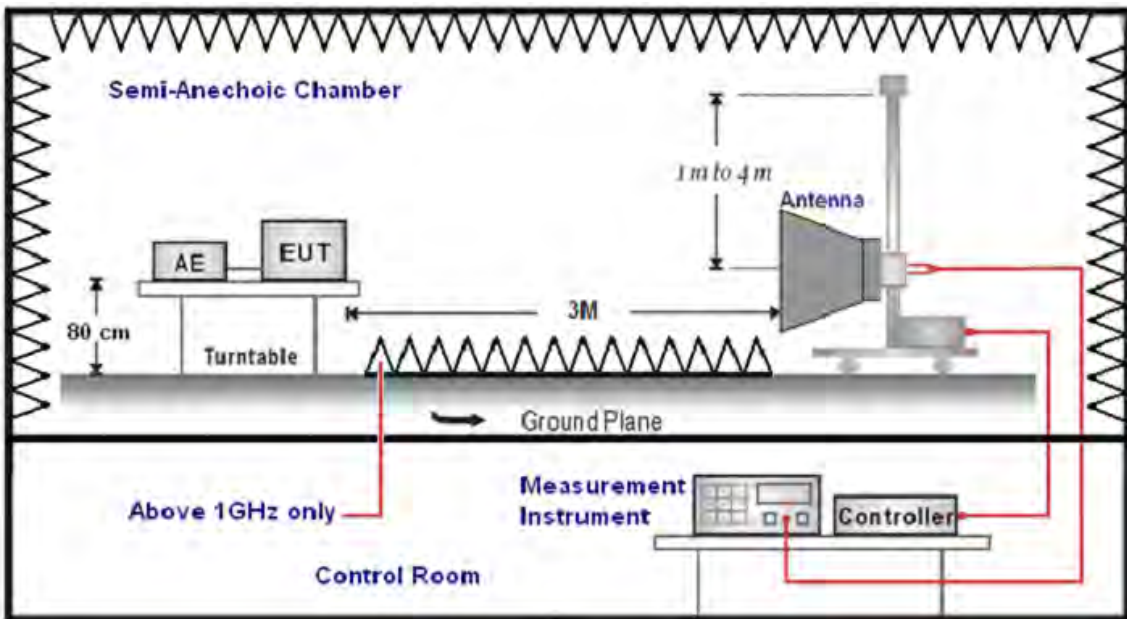

4.2.4. Test Procedure

The EUT and its simulators are placed on a turn table which is 0.8 meter above ground. When the EUT is floor-standing equipment, it is placed on the ground plane which has a 3-12 mm non-conductive covering to insulate the EUT from the ground plane.

The turn table can rotate 360 degrees to determine the position of the maximum emission level. The EUT was positioned such that the distance from antenna to the EUT was 10 meters for under 1GHz, and 3 meter for above 1GHz, the highest frequency performed according to internal source frequency of the EUT, the specification was below:

Highest frequency generated or used in the device or on which the device operates or tunes (MHz)	Upper frequency of measurement range (MHz)
Below 1.705	30
1.705 - 108	1000
108 - 500	2000
500 - 1000	5000
Above 1000	5th harmonic of the highest frequency or 40 GHz, whichever is lower

According to this standard paragraph 15.109, as an alternative to the radiated emission limits, digital devices may be shown to comply with the standards contained in Third Edition of the International Special Committee on Radio Interference (CISPR), Pub. 22, "Information Technology Equipment - Radio Disturbance Characteristics - Limits and Methods of Measurement".

The antenna can move up and down between 1 meter and 4 meters to find out the maximum emission level. Both horizontal and vertical polarization of the antenna are set on measurement. In order to find the maximum emission, all of the interface cables must be manipulated on radiated measurement.

Radiated emissions were investigated over the frequency range from 30MHz to 1GHz using a receiver bandwidth of 120 kHz. Radiated was performed at an antenna to EUT distance of 10 meters.

4.2.5. Test Result

Standard:	CISPR 22 Class B	Test Distance:	10m
Test item:	Radiated Emission	Power:	DC 3.8V
Model Number:	HE910-NAG	Temp.(°C)/Hum.(%RH):	26(°C)/60%RH
Mode:	1	Date:	04/12/2012
Ant.Polar.:	Horizontal	Test By:	Charlie Chang

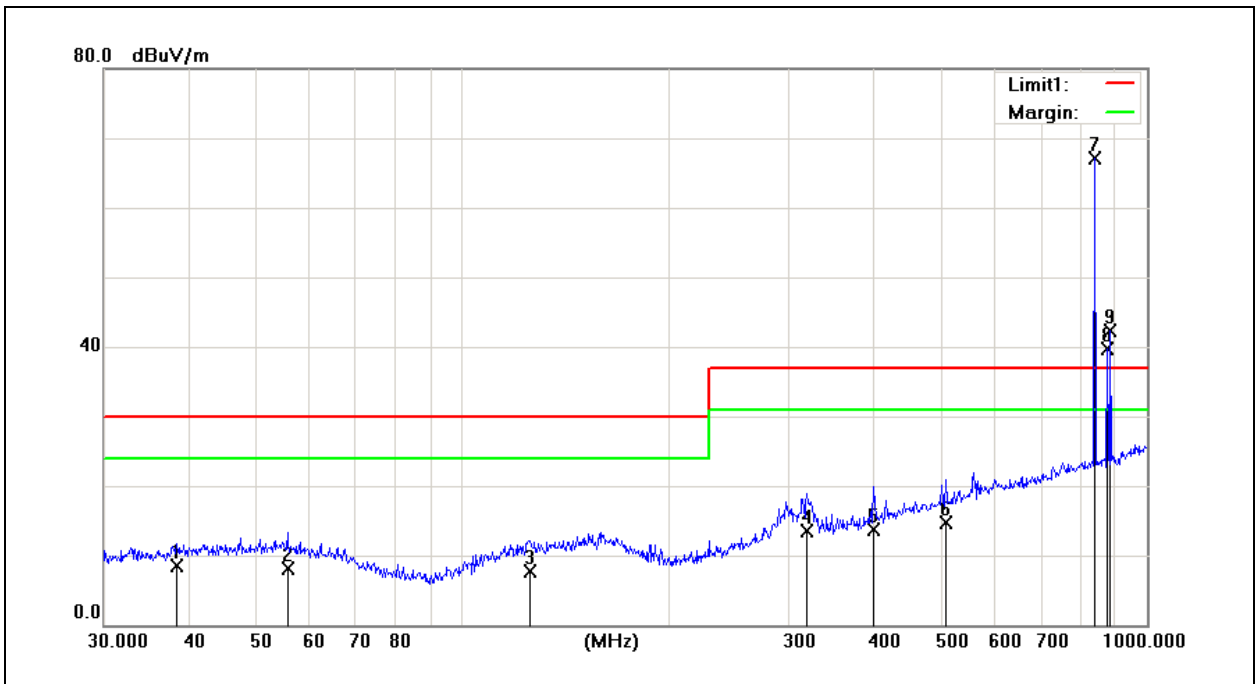

No.	Frequency (MHz)	Reading (dBuV)	Correct Factor(dB/m)	Result (dBuV/m)	Limit (dBuV/m)	Margin (dB)	Height (cm)	Degree (°)	Remark
1	38.3462	23.58	-14.98	8.60	30.00	-21.40	300	0	QP
2	55.6094	22.81	-14.61	8.20	30.00	-21.80	300	1	QP
3	125.8864	21.87	-14.07	7.80	30.00	-22.20	229	360	QP
4	318.8170	24.73	-11.23	13.50	37.00	-23.50	396	0	QP
5	399.0300	23.54	-9.74	13.80	37.00	-23.20	400	100	QP
6	508.2582	22.42	-7.72	14.70	37.00	-22.30	200	315	QP
7	839.1817	68.82	-1.69	67.13	N/A	N/A	300	0	TX
8	875.2470	40.70	-1.03	39.67	N/A	N/A	400	94	BS
9	884.5028	43.19	-0.87	42.32	N/A	N/A	400	44	RX

Note: TX: the transmitting signal of Universal Radio Communication Tester.

RX: the receiving signal of Universal Radio Communication Tester.

BS: the signal of Universal Radio Communication Tester.

Standard:	CISPR 22 Class B	Test Distance:	10m
Test item:	Radiated Emission	Power:	DC 3.8V
Model Number:	HE910-NAG	Temp.(°C)/Hum.(%RH):	26(°C)/60%RH
Mode:	1	Date:	04/12/2012
Ant.Polar.:	Vertical	Test By:	Charlie Chang

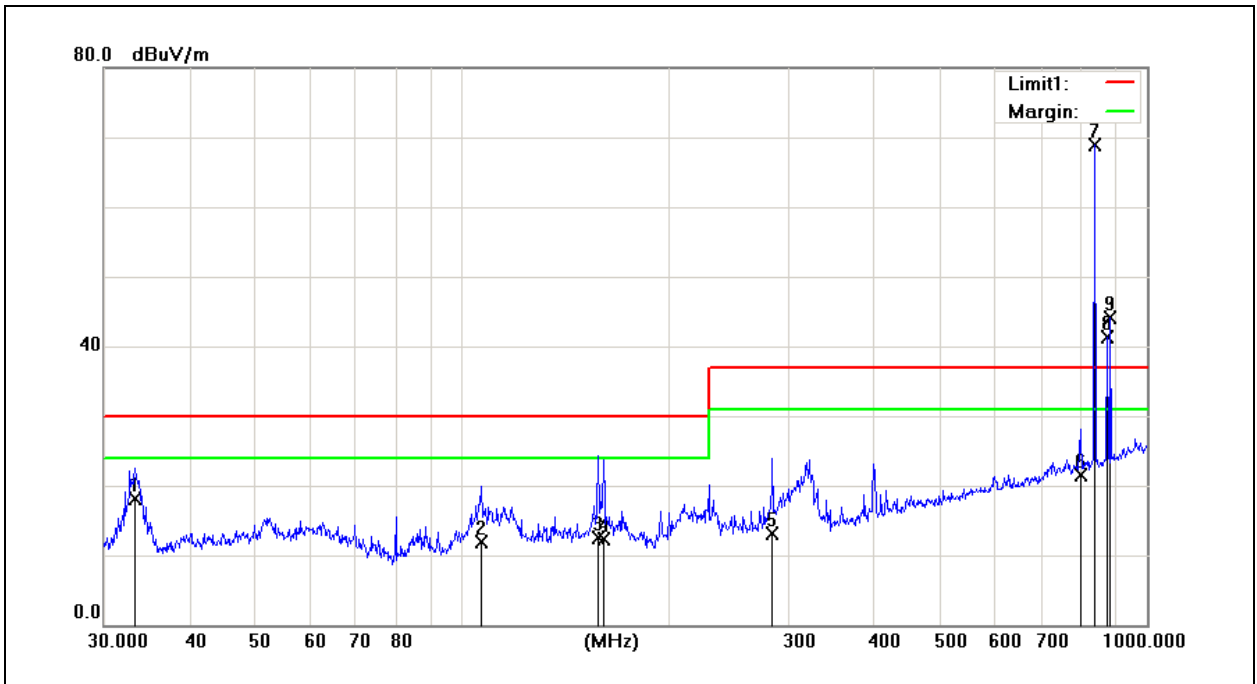

No.	Frequency (MHz)	Reading (dBuV)	Correct Factor(dB/m)	Result (dBuV/m)	Limit (dBuV/m)	Margin (dB)	Height (cm)	Degree (°)	Remark
1	33.3280	32.66	-14.46	18.20	30.00	-11.80	101	0	QP
2	106.7587	27.29	-15.39	11.90	30.00	-18.10	193	0	QP
3	158.1123	24.41	-11.91	12.50	30.00	-17.50	100	208	QP
4	160.9090	24.17	-11.87	12.30	30.00	-17.70	100	268	QP
5	283.9791	23.76	-10.56	13.20	37.00	-23.80	100	126	QP
6	798.9797	21.72	-0.22	21.50	37.00	-15.50	300	71	QP
7	839.1817	68.62	0.35	68.97	N/A	N/A	200	152	TX
8	875.2470	40.35	1.02	41.37	N/A	N/A	300	332	BS
9	884.5028	43.04	1.16	44.20	N/A	N/A	100	25	RX

Note: TX: the transmitting signal of Universal Radio Communication Tester.

RX: the receiving signal of Universal Radio Communication Tester.

BS: the signal of Universal Radio Communication Tester.

Standard:	FCC Part 15B Class B	Test Distance:	3m
Test item:	Radiated Emission	Power:	DC 3.8V
Model Number:	HE910-NAG	Temp.(°C)/Hum.(%RH):	26(°C)/60%RH
Mode:	1 (1GHz~10GHz)	Date:	04/13/2012
Ant.Polar.:	Horizontal	Test By:	Charlie Chang

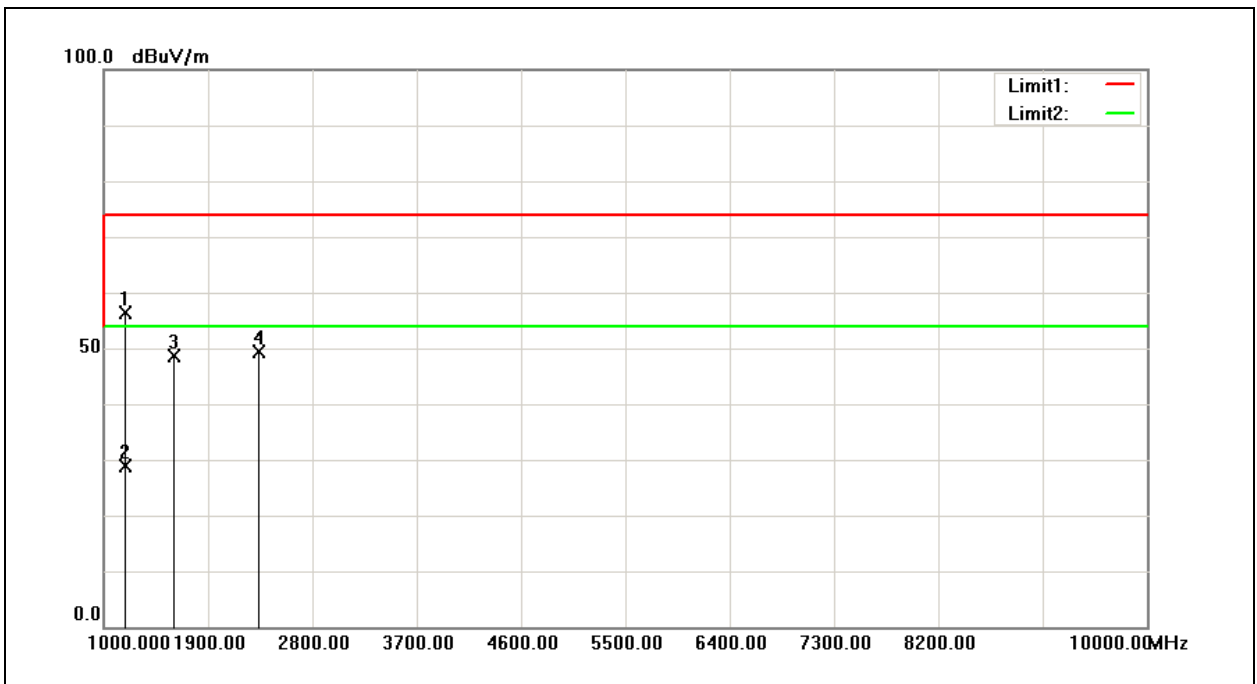

No.	Frequency (MHz)	Reading (dBuV)	Correct Factor(dB/m)	Result (dBuV/m)	Limit (dBuV/m)	Margin (dB)	Remark
1	1175.000	83.33	-26.86	56.47	74.00	-17.53	peak
2	1175.000	55.65	-26.86	28.79	54.00	-25.21	AVG
3	1595.000	74.14	-25.57	48.57	74.00	-25.43	peak
4	2340.000	72.95	-23.67	49.28	74.00	-24.72	peak

Standard:	FCC Part 15B Class B	Test Distance:	3m
Test item:	Radiated Emission	Power:	DC 3.8V
Model Number:	HE910-NAG	Temp.(°C)/Hum.(%RH):	26(°C)/60%RH
Mode:	1 (1GHz~10GHz)	Date:	04/13/2012
Ant.Polar.:	Vertical	Test By:	Charlie Chang

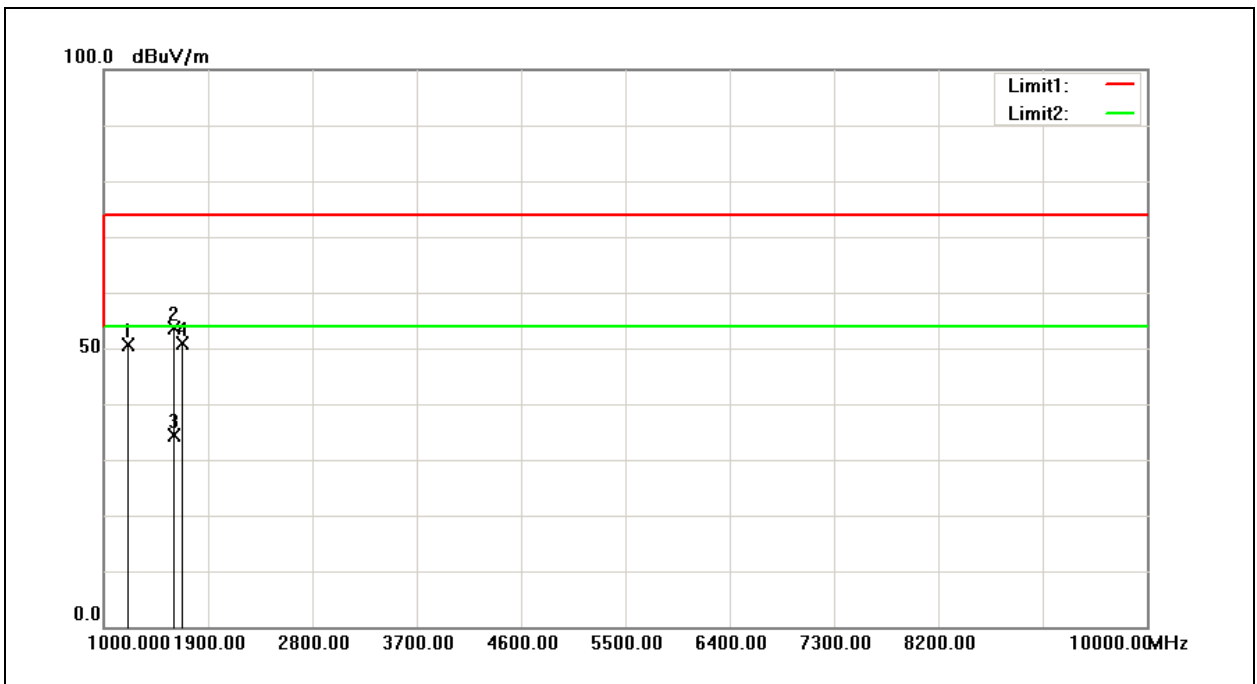

No.	Frequency (MHz)	Reading (dBuV)	Correct Factor(dB/m)	Result (dBuV/m)	Limit (dBuV/m)	Margin (dB)	Remark
1	1200.000	77.39	-26.77	50.62	74.00	-23.38	peak
2	1600.000	79.08	-25.55	53.53	74.00	-20.47	peak
3	1600.000	59.91	-25.55	34.36	54.00	-19.64	AVG
4	1675.000	76.28	-25.41	50.87	74.00	-23.13	peak

Standard:	CISPR 22 Class B	Test Distance:	10m
Test item:	Radiated Emission	Power:	DC 3.8V
Model Number:	HE910-NAG	Temp.(°C)/Hum.(%RH):	26(°C)/60%RH
Mode:	2	Date:	04/12/2012
Ant.Polar.:	Horizontal	Test By:	Charlie Chang

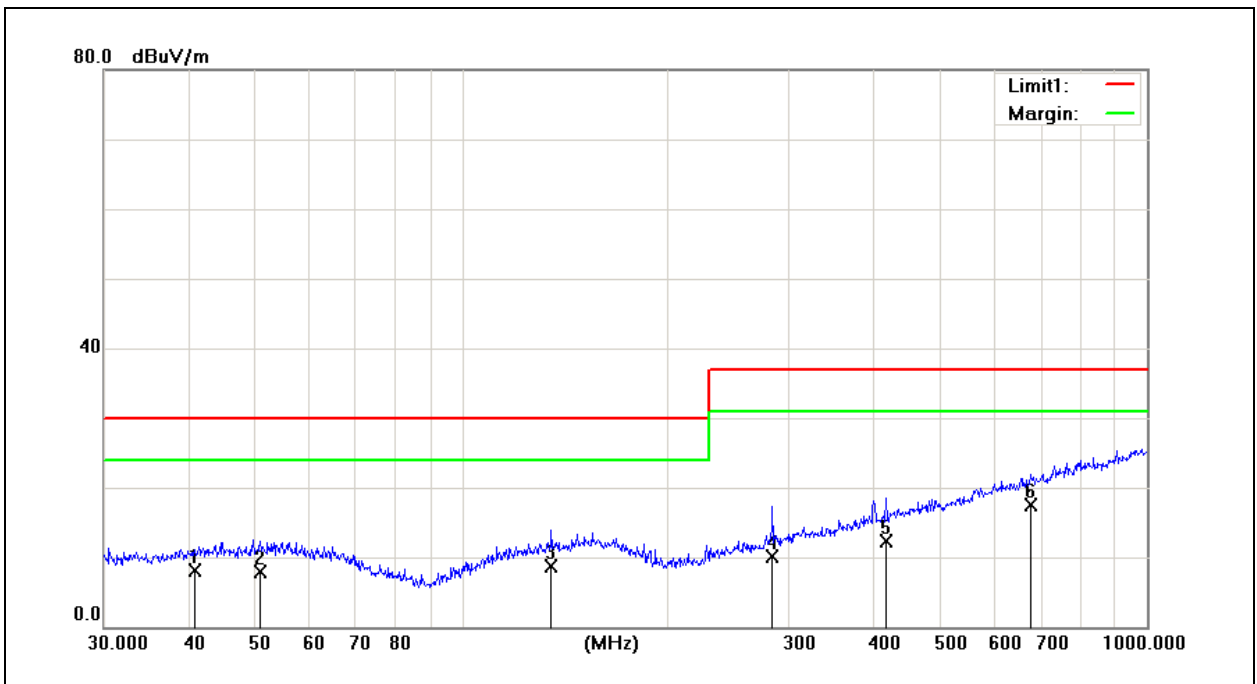

No.	Frequency (MHz)	Reading (dBuV)	Correct Factor(dB/m)	Result (dBuV/m)	Limit (dBuV/m)	Margin (dB)	Height (cm)	Degree (°)	Remark
1	40.7016	23.05	-14.85	8.20	30.00	-21.80	200	312	QP
2	50.7637	22.17	-14.27	7.90	30.00	-22.10	300	0	QP
3	135.0320	22.42	-13.62	8.80	30.00	-21.20	400	37	QP
4	283.9791	22.21	-12.01	10.20	37.00	-26.80	300	0	QP
5	416.1791	21.67	-9.27	12.40	37.00	-24.60	300	28	QP
6	675.2080	22.07	-4.57	17.50	37.00	-19.50	400	210	QP

Standard:	CISPR 22 Class B	Test Distance:	10m
Test item:	Radiated Emission	Power:	DC 3.8V
Model Number:	HE910-NAG	Temp.(°C)/Hum.(%RH):	26(°C)/60%RH
Mode:	2	Date:	04/12/2012
Ant.Polar.:	Vertical	Test By:	Charlie Chang

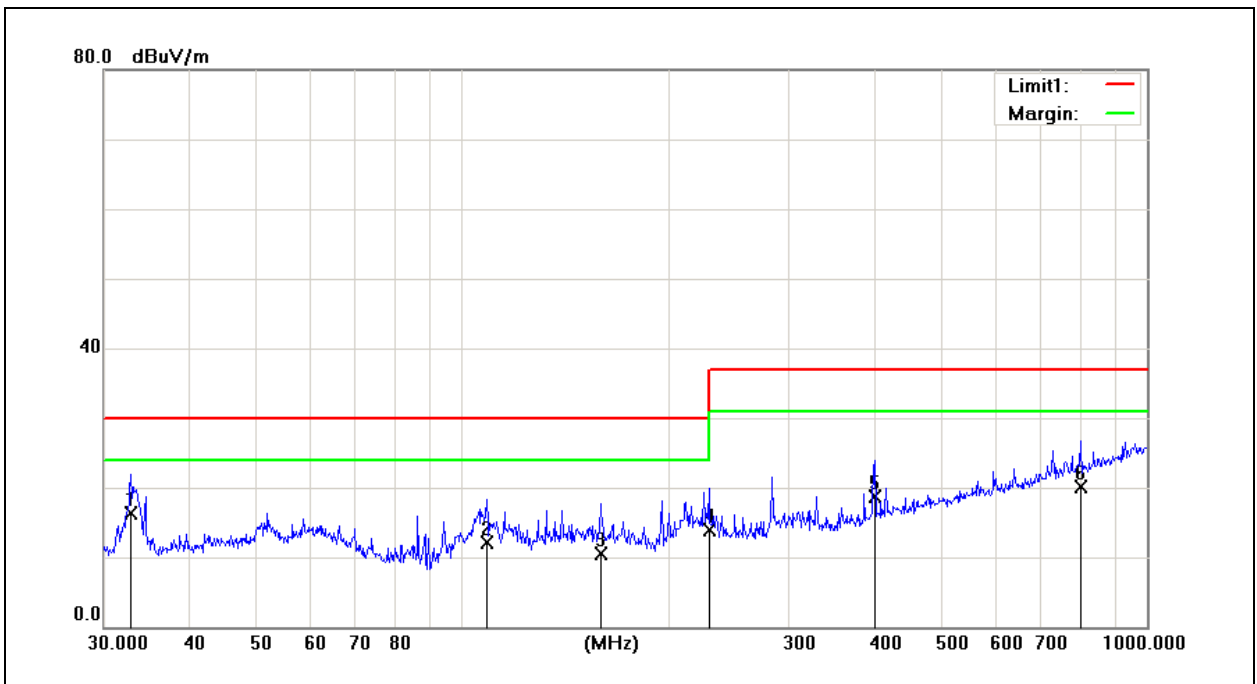

No.	Frequency (MHz)	Reading (dBuV)	Correct Factor(dB/m)	Result (dBuV/m)	Limit (dBuV/m)	Margin (dB)	Height (cm)	Degree (°)	Remark
1	32.8637	30.88	-14.48	16.40	30.00	-13.60	200	173	QP
2	108.6470	27.19	-14.99	12.20	30.00	-17.80	124	0	QP
3	159.2251	22.39	-11.89	10.50	30.00	-19.50	300	125	QP
4	229.2931	26.64	-12.74	13.90	30.00	-16.10	100	40	QP
5	400.4320	26.84	-8.04	18.80	37.00	-18.20	100	155	QP
6	798.9797	20.42	-0.22	20.20	37.00	-16.80	100	57	QP

Standard:	FCC Part 15B Class B	Test Distance:	3m
Test item:	Radiated Emission	Power:	DC 3.8V
Model Number:	HE910-NAG	Temp.(°C)/Hum.(%RH):	26(°C)/60%RH
Mode:	2 (1GHz~10GHz)	Date:	04/13/2012
Ant.Polar.:	Horizontal	Test By:	Charlie Chang

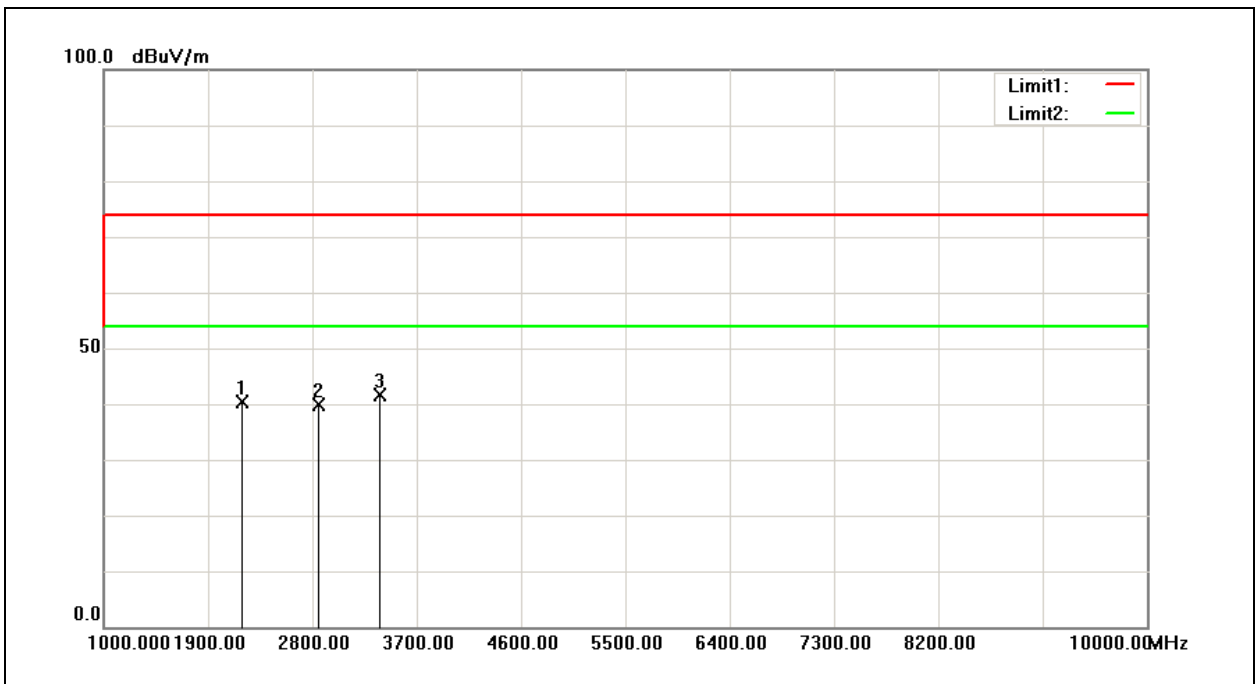

No.	Frequency (MHz)	Reading (dBuV)	Correct Factor(dB/m)	Result (dBuV/m)	Limit (dBuV/m)	Margin (dB)	Remark
1	2185.000	64.51	-24.18	40.33	74.00	-33.67	peak
2	2850.000	61.85	-21.97	39.88	74.00	-34.12	peak
3	3385.000	62.52	-20.83	41.69	74.00	-32.31	peak

Standard:	FCC Part 15B Class B	Test Distance:	3m
Test item:	Radiated Emission	Power:	DC 3.8V
Model Number:	HE910-NAG	Temp.(°C)/Hum.(%RH):	26(°C)/60%RH
Mode:	2 (1GHz~10GHz)	Date:	04/13/2012
Ant.Polar.:	Vertical	Test By:	Charlie Chang

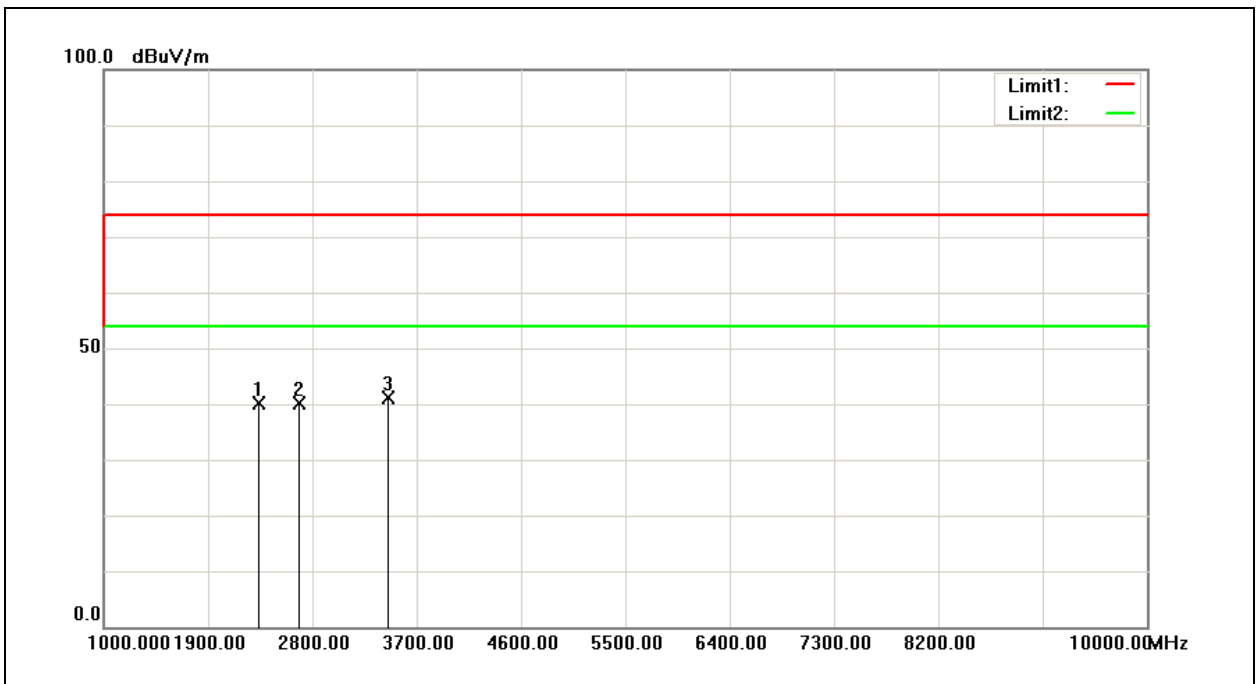

No.	Frequency (MHz)	Reading (dBuV)	Correct Factor(dB/m)	Result (dBuV/m)	Limit (dBuV/m)	Margin (dB)	Remark
1	2325.000	63.97	-23.72	40.25	74.00	-33.75	peak
2	2675.000	62.78	-22.55	40.23	74.00	-33.77	peak
3	3445.000	61.89	-20.73	41.16	74.00	-32.84	peak

Standard:	CISPR 22 Class B	Test Distance:	10m
Test item:	Radiated Emission	Power:	DC 3.8V
Model Number:	HE910-NAG	Temp.(°C)/Hum.(%RH):	26(°C)/60%RH
Mode:	3	Date:	04/12/2012
Ant.Polar.:	Horizontal	Test By:	Charlie Chang

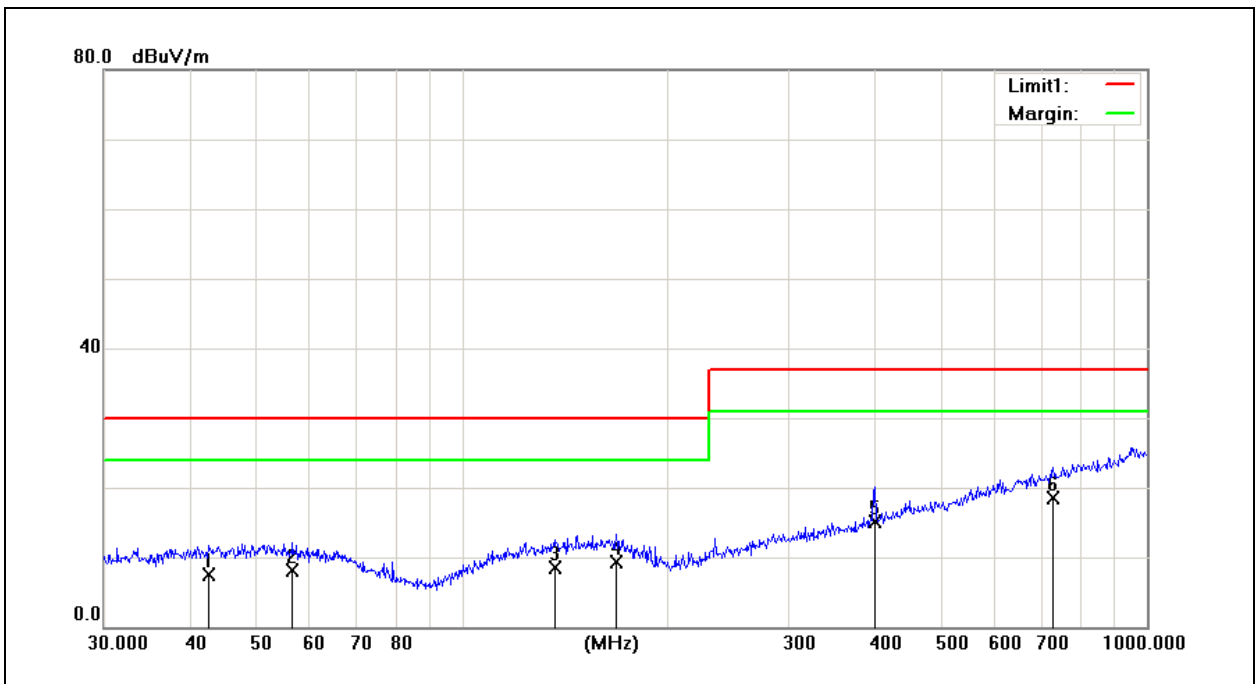

No.	Frequency (MHz)	Reading (dBuV)	Correct Factor(dB/m)	Result (dBuV/m)	Limit (dBuV/m)	Margin (dB)	Height (cm)	Degree (°)	Remark
1	42.6000	22.28	-14.68	7.60	30.00	-22.40	200	0	QP
2	56.5930	22.87	-14.67	8.20	30.00	-21.80	272	0	QP
3	136.4598	22.07	-13.57	8.50	30.00	-21.50	200	179	QP
4	167.8243	22.34	-13.04	9.30	30.00	-20.70	200	272	QP
5	400.4320	24.80	-9.70	15.10	37.00	-21.90	200	103	QP
6	729.3583	21.90	-3.40	18.50	37.00	-18.50	300	344	QP

Standard:	CISPR 22 Class B	Test Distance:	10m
Test item:	Radiated Emission	Power:	DC 3.8V
Model Number:	HE910-NAG	Temp.(°C)/Hum.(%RH):	26(°C)/60%RH
Mode:	3	Date:	04/12/2012
Ant.Polar.:	Vertical	Test By:	Charlie Chang

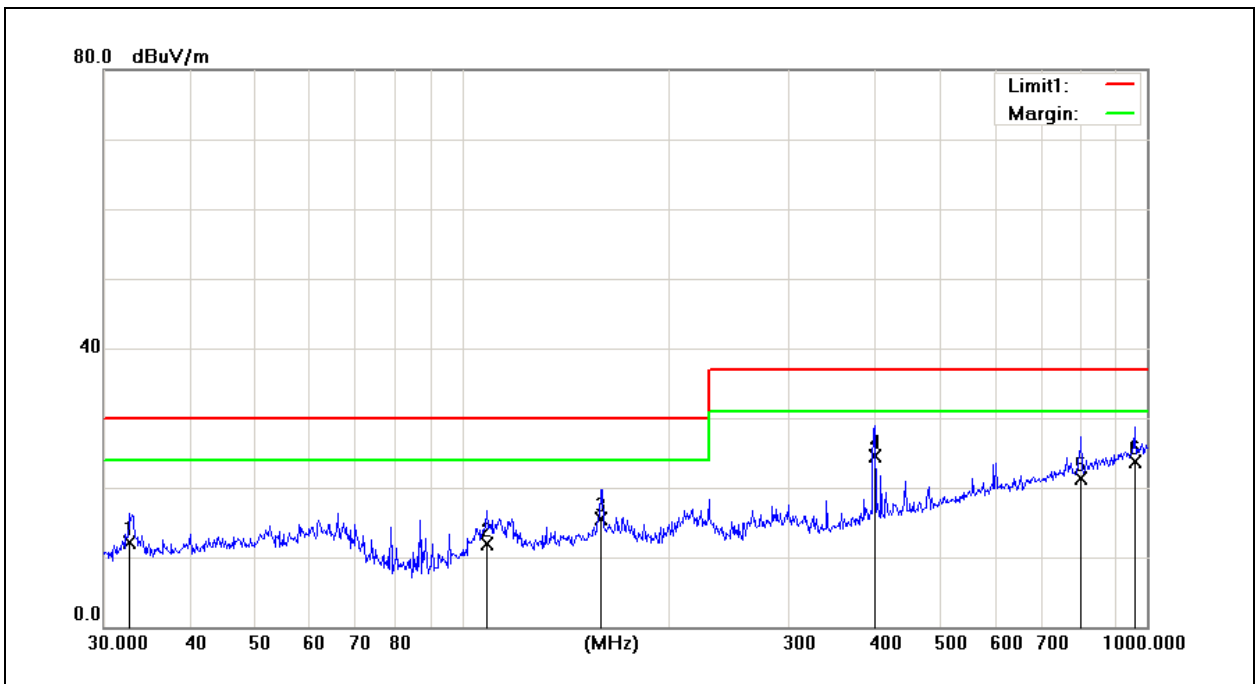

No.	Frequency (MHz)	Reading (dBuV)	Correct Factor(dB/m)	Result (dBuV/m)	Limit (dBuV/m)	Margin (dB)	Height (cm)	Degree (°)	Remark
1	32.7486	26.69	-14.49	12.20	30.00	-17.80	100	357	QP
2	108.6470	26.89	-14.99	11.90	30.00	-18.10	133	357	QP
3	159.2251	27.39	-11.89	15.50	30.00	-14.50	346	360	QP
4	400.4320	32.54	-8.04	24.50	37.00	-12.50	300	127	QP
5	801.7863	21.60	-0.20	21.40	37.00	-15.60	200	89	QP
6	958.7943	20.80	2.90	23.70	37.00	-13.30	400	59	QP

Standard:	FCC Part 15B Class B	Test Distance:	3m
Test item:	Radiated Emission	Power:	DC 3.8V
Model Number:	HE910-NAG	Temp.(°C)/Hum.(%RH):	26(°C)/60%RH
Mode:	3 (1GHz~10GHz)	Date:	04/13/2012
Ant.Polar.:	Horizontal	Test By:	Charlie Chang

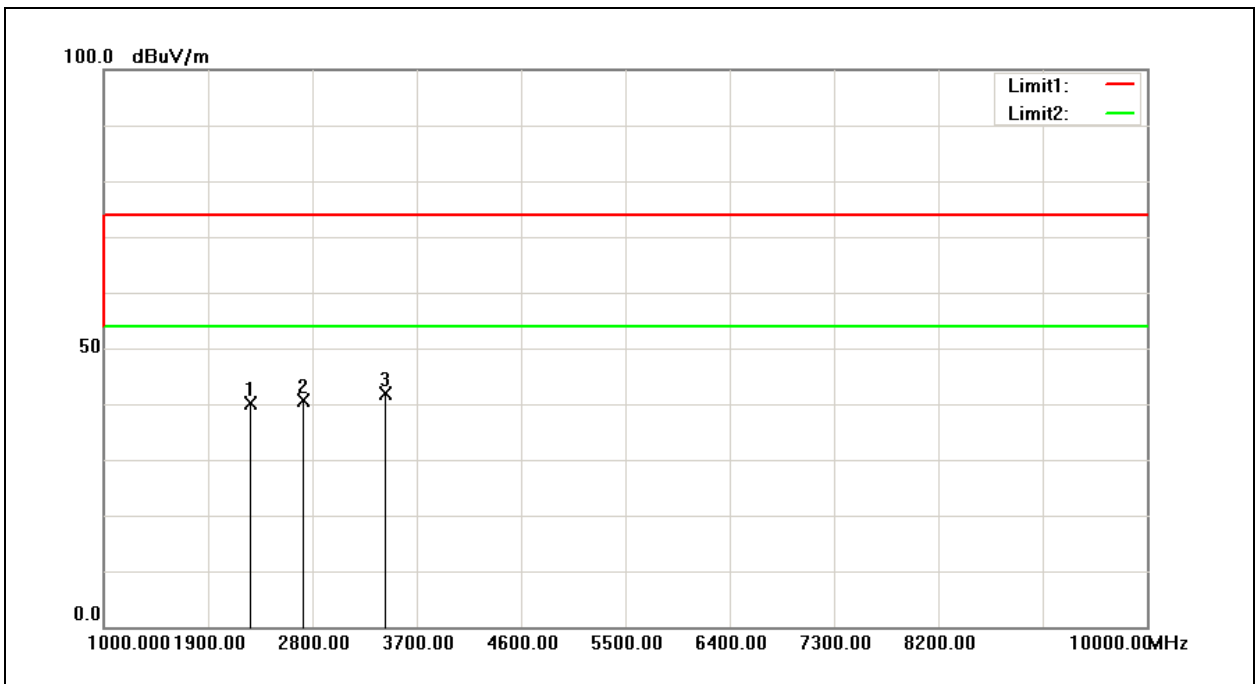

No.	Frequency (MHz)	Reading (dBuV)	Correct Factor(dB/m)	Result (dBuV/m)	Limit (dBuV/m)	Margin (dB)	Remark
1	2255.000	64.06	-23.95	40.11	74.00	-33.89	peak
2	2715.000	62.94	-22.42	40.52	74.00	-33.48	peak
3	3430.000	62.66	-20.76	41.90	74.00	-32.10	peak

Standard:	FCC Part 15B Class B	Test Distance:	3m
Test item:	Radiated Emission	Power:	DC 3.8V
Model Number:	HE910-NAG	Temp.(°C)/Hum.(%RH):	26(°C)/60%RH
Mode:	3 (1GHz~10GHz)	Date:	04/13/2012
Ant.Polar.:	Vertical	Test By:	Charlie Chang

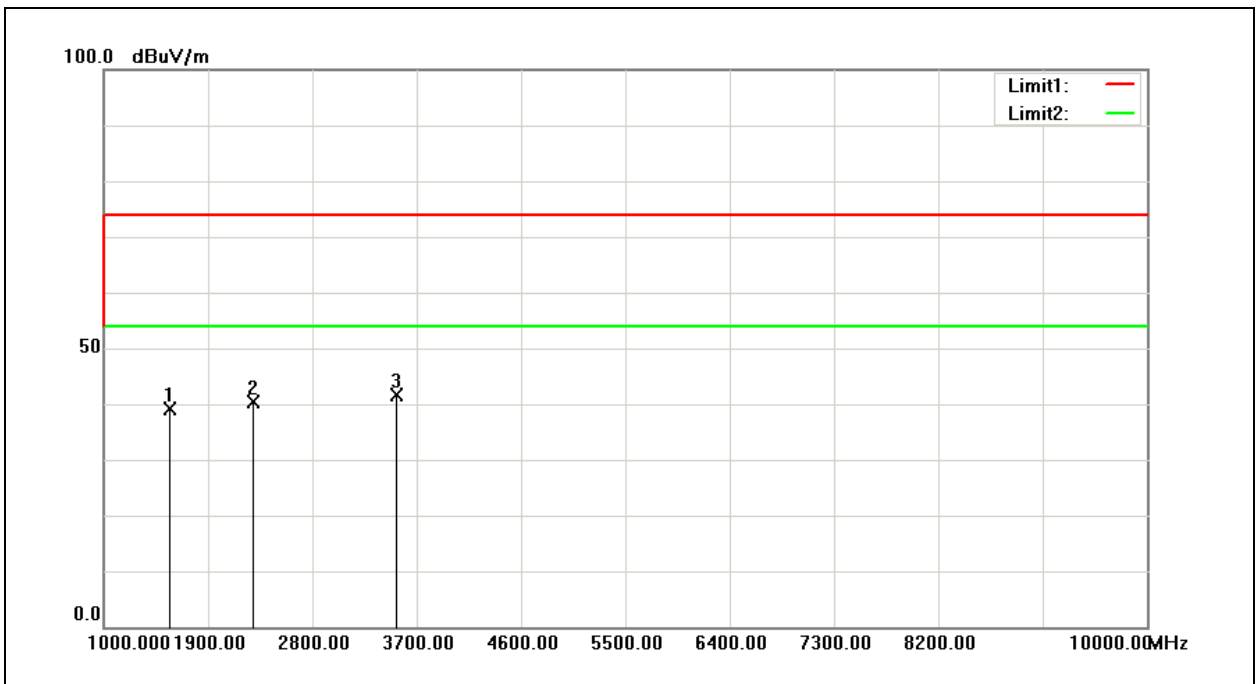

No.	Frequency (MHz)	Reading (dBuV)	Correct Factor(dB/m)	Result (dBuV/m)	Limit (dBuV/m)	Margin (dB)	Remark
1	1565.000	64.64	-25.62	39.02	74.00	-34.98	peak
2	2285.000	64.23	-23.85	40.38	74.00	-33.62	peak
3	3525.000	62.21	-20.54	41.67	74.00	-32.33	peak

Standard:	CISPR 22 Class B	Test Distance:	10m
Test item:	Radiated Emission	Power:	DC 3.8V
Model Number:	HE910-NAG	Temp.(°C)/Hum.(%RH):	26(°C)/60%RH
Mode:	4	Date:	04/12/2012
Ant.Polar.:	Horizontal	Test By:	Charlie Chang

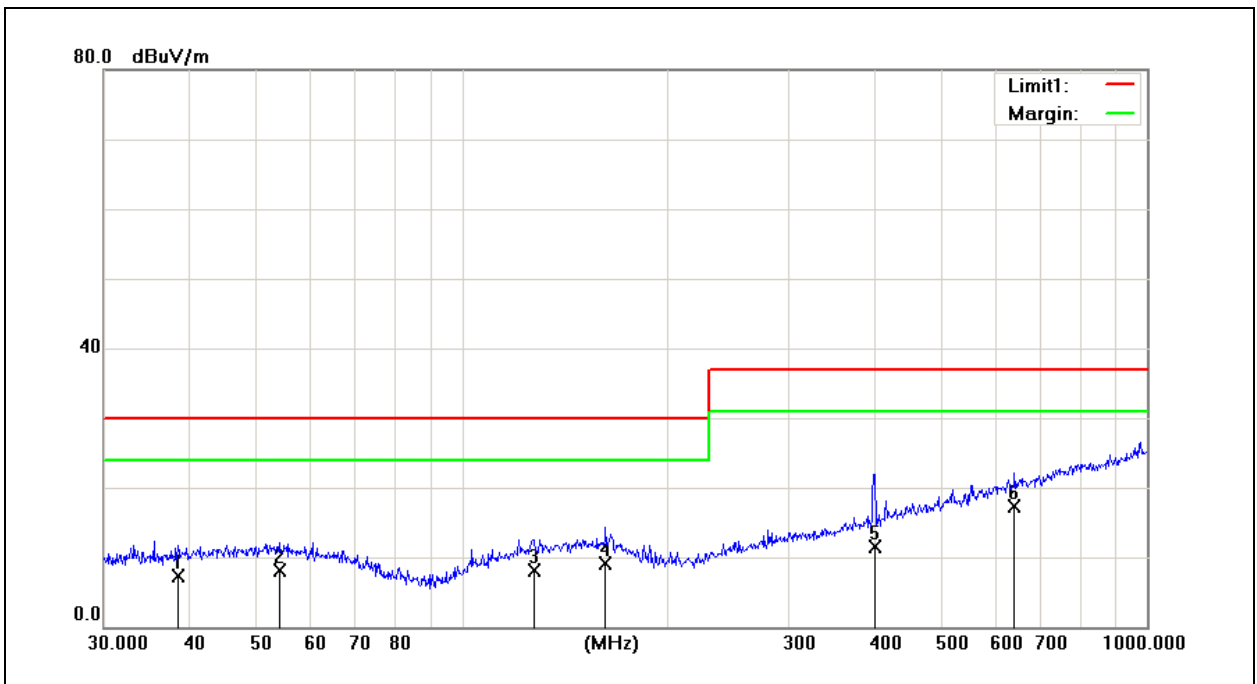

No.	Frequency (MHz)	Reading (dBuV)	Correct Factor(dB/m)	Result (dBuV/m)	Limit (dBuV/m)	Margin (dB)	Height (cm)	Degree (°)	Remark
1	38.4810	22.38	-14.98	7.40	30.00	-22.60	200	95	QP
2	54.0711	22.71	-14.51	8.20	30.00	-21.80	200	202	QP
3	127.6645	22.10	-14.00	8.10	30.00	-21.90	400	359	QP
4	162.0414	22.00	-12.80	9.20	30.00	-20.80	100	359	QP
5	400.4320	21.20	-9.70	11.50	37.00	-25.50	300	110	QP
6	640.6110	22.18	-4.88	17.30	37.00	-19.70	300	230	QP

Standard:	CISPR 22 Class B	Test Distance:	10m
Test item:	Radiated Emission	Power:	DC 3.8V
Model Number:	HE910-NAG	Temp.(°C)/Hum.(%RH):	26(°C)/60%RH
Mode:	4	Date:	04/12/2012
Ant.Polar.:	Vertical	Test By:	Charlie Chang

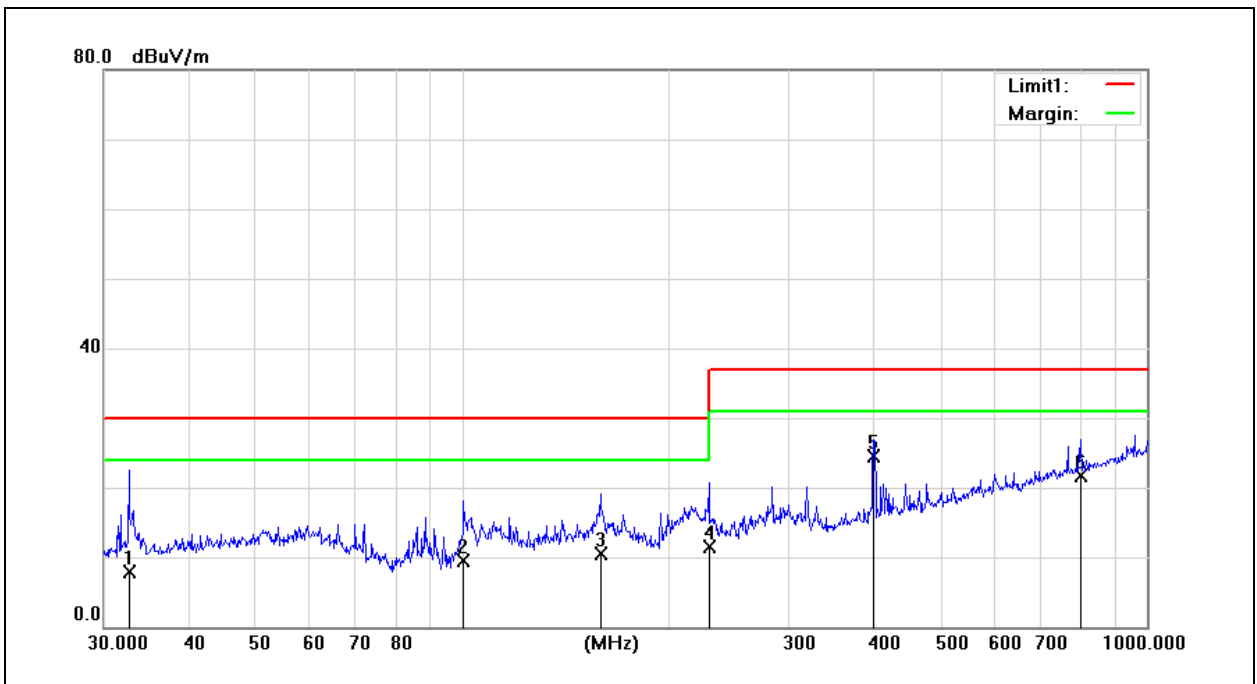

No.	Frequency (MHz)	Reading (dBuV)	Correct Factor(dB/m)	Result (dBuV/m)	Limit (dBuV/m)	Margin (dB)	Height (cm)	Degree (°)	Remark
1	32.6340	22.39	-14.49	7.90	30.00	-22.10	300	211	QP
2	100.5806	26.19	-16.69	9.50	30.00	-20.50	400	28	QP
3	159.2251	22.49	-11.89	10.60	30.00	-19.40	300	185	QP
4	229.2931	24.34	-12.74	11.60	30.00	-18.40	100	186	QP
5	399.0302	32.58	-8.08	24.50	37.00	-12.50	100	209	QP
6	798.9797	21.92	-0.22	21.70	37.00	-15.30	100	313	QP

Standard:	FCC Part 15B Class B	Test Distance:	3m
Test item:	Radiated Emission	Power:	DC 3.8V
Model Number:	HE910-NAG	Temp.(°C)/Hum.(%RH):	26(°C)/60%RH
Mode:	4 (1GHz~10GHz)	Date:	04/13/2012
Ant.Polar.:	Horizontal	Test By:	Charlie Chang

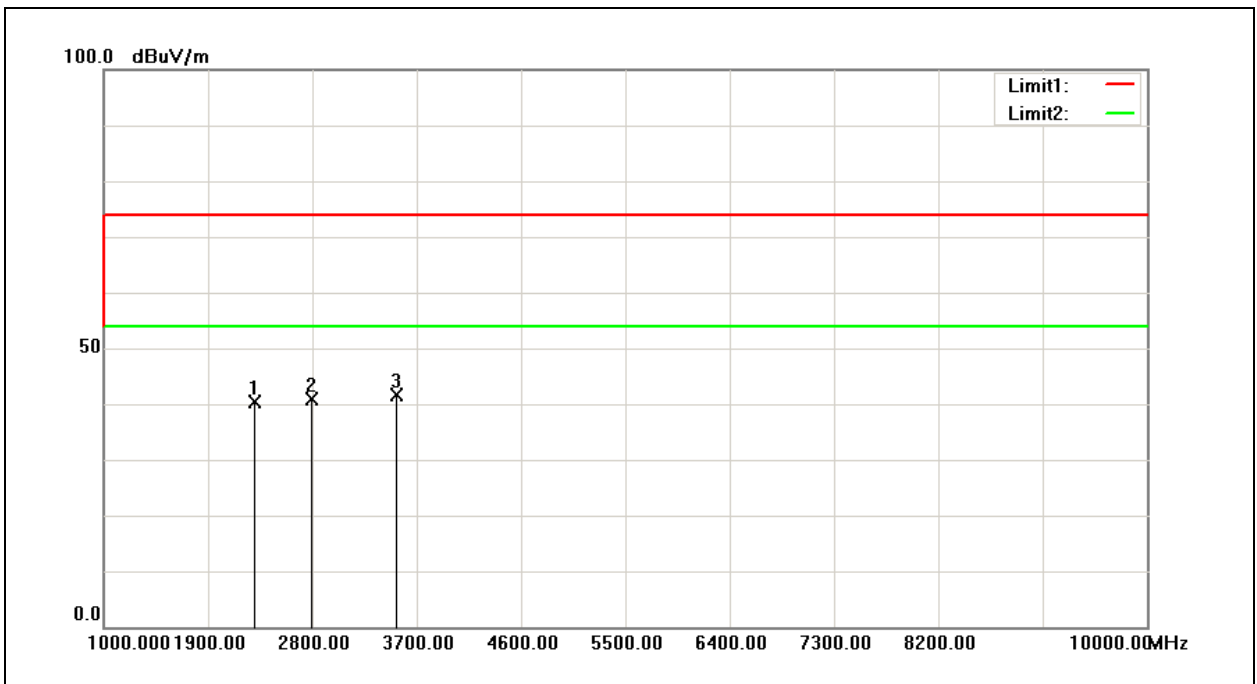

No.	Frequency (MHz)	Reading (dBuV)	Correct Factor(dB/m)	Result (dBuV/m)	Limit (dBuV/m)	Margin (dB)	Remark
1	2290.000	64.22	-23.84	40.38	74.00	-33.62	peak
2	2790.000	63.12	-22.17	40.95	74.00	-33.05	peak
3	3520.000	62.26	-20.57	41.69	74.00	-32.31	peak

Standard:	FCC Part 15B Class B	Test Distance:	3m
Test item:	Radiated Emission	Power:	DC 3.8V
Model Number:	HE910-NAG	Temp.(°C)/Hum.(%RH):	26(°C)/60%RH
Mode:	4 (1GHz~10GHz)	Date:	04/13/2012
Ant.Polar.:	Vertical	Test By:	Charlie Chang

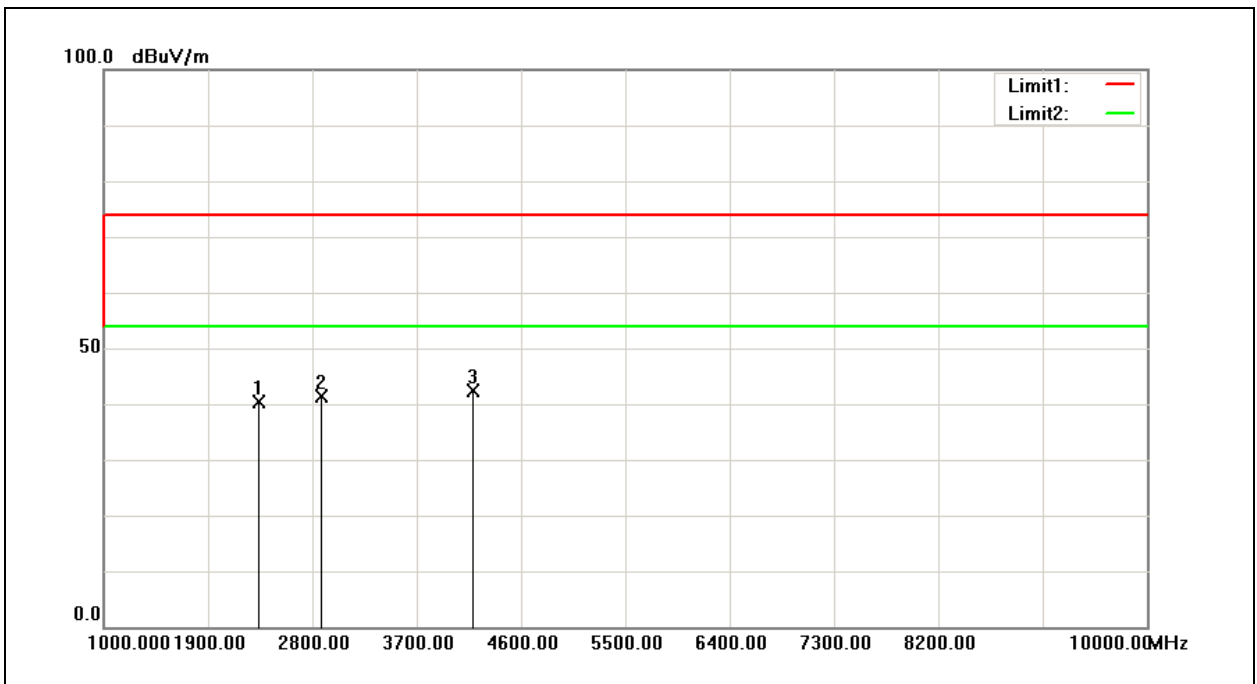

No.	Frequency (MHz)	Reading (dBuV)	Correct Factor(dB/m)	Result (dBuV/m)	Limit (dBuV/m)	Margin (dB)	Remark
1	2335.000	64.04	-23.68	40.36	74.00	-33.64	peak
2	2870.000	63.17	-21.90	41.27	74.00	-32.73	peak
3	4180.000	60.47	-18.07	42.40	74.00	-31.60	peak

Standard:	CISPR 22 Class B	Test Distance:	10m
Test item:	Radiated Emission	Power:	DC 3.8V
Model Number:	HE910-NAG	Temp.(°C)/Hum.(%RH):	26(°C)/60%RH
Mode:	5	Date:	04/12/2012
Ant.Polar.:	Horizontal	Test By:	Charlie Chang

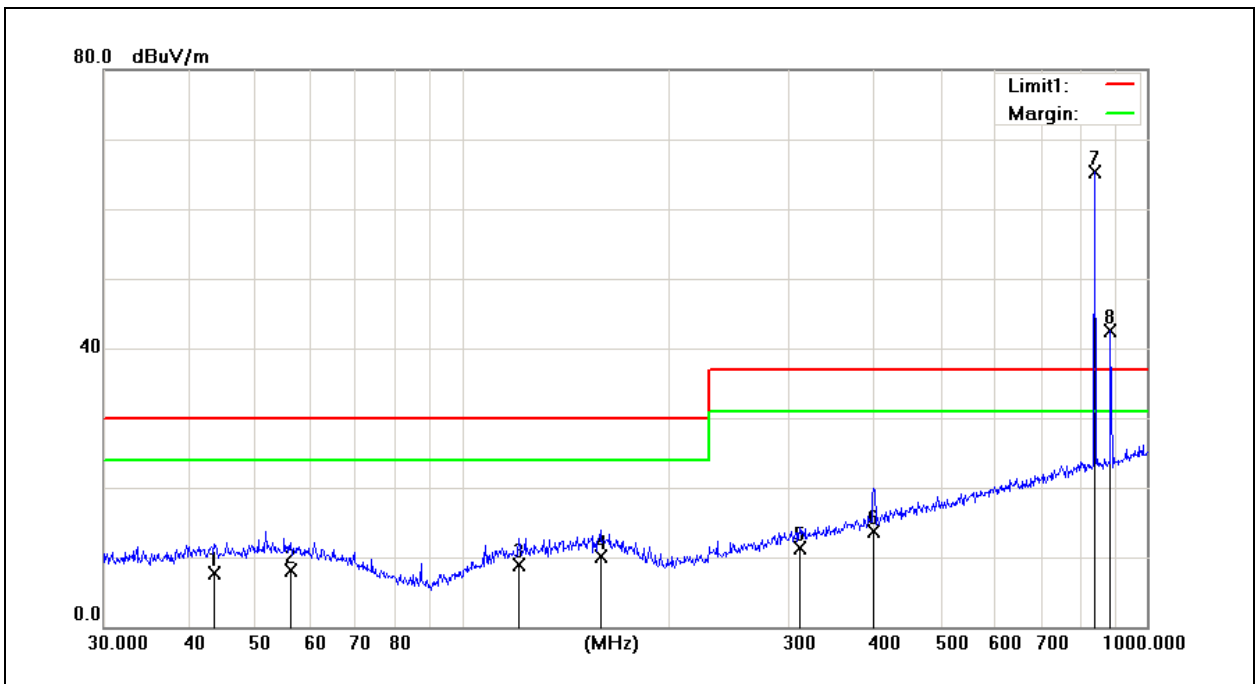

No.	Frequency (MHz)	Reading (dBuV)	Correct Factor(dB/m)	Result (dBuV/m)	Limit (dBuV/m)	Margin (dB)	Height (cm)	Degree (°)	Remark
1	43.5057	22.31	-14.61	7.70	30.00	-22.30	398	360	QP
2	56.1974	22.85	-14.65	8.20	30.00	-21.80	300	204	QP
3	121.1231	23.14	-14.24	8.90	30.00	-21.10	400	181	QP
4	159.2251	22.87	-12.77	10.10	30.00	-19.90	400	0	QP
5	311.0867	22.59	-11.29	11.30	37.00	-25.70	400	259	QP
6	399.0302	23.54	-9.74	13.80	37.00	-23.20	300	97	QP
7	839.1818	66.97	-1.69	65.28	N/A	N/A	400	359	TX
8	884.5030	43.41	-0.87	42.54	N/A	N/A	200	0	RX

Note: TX: the transmitting signal of Universal Radio Communication Tester.

RX: the receiving signal of Universal Radio Communication Tester.

Standard:	CISPR 22 Class B	Test Distance:	10m
Test item:	Radiated Emission	Power:	DC 3.8V
Model Number:	HE910-NAG	Temp.(°C)/Hum.(%RH):	26(°C)/60%RH
Mode:	5	Date:	04/12/2012
Ant.Polar.:	Vertical	Test By:	Charlie Chang

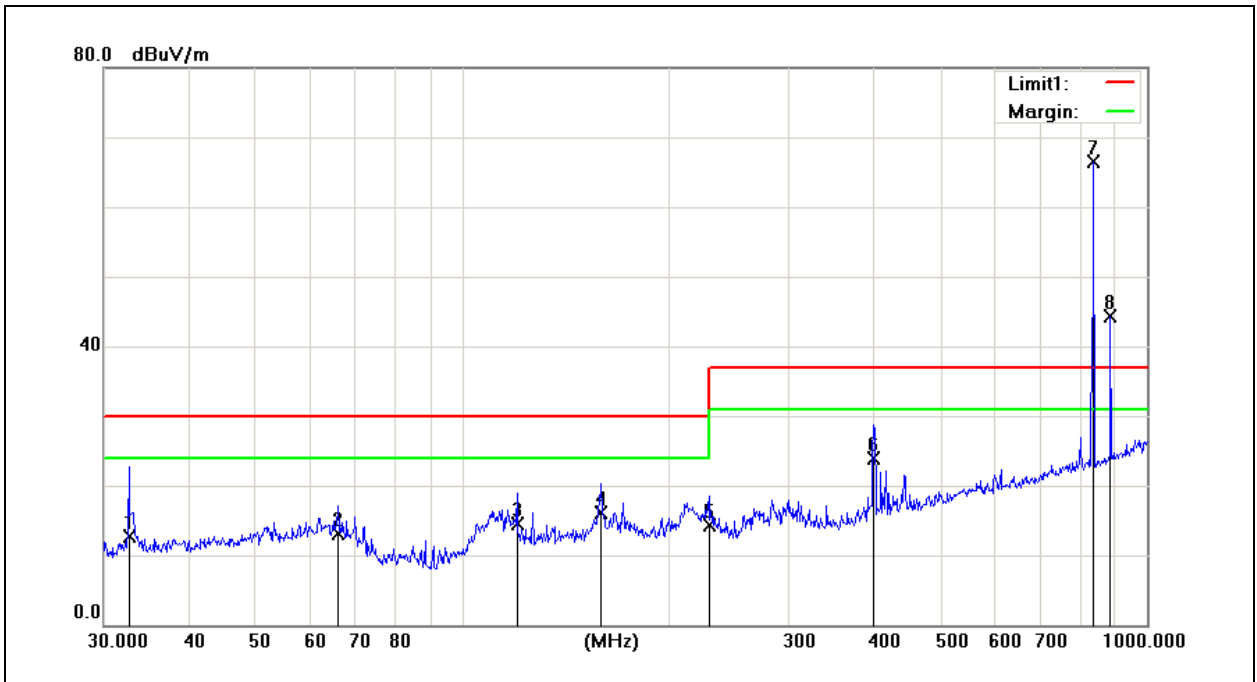

No.	Frequency (MHz)	Reading (dBuV)	Correct Factor(dB/m)	Result (dBuV/m)	Limit (dBuV/m)	Margin (dB)	Height (cm)	Degree (°)	Remark
1	32.6340	27.19	-14.49	12.70	30.00	-17.30	100	319	QP
2	66.0342	28.56	-15.36	13.20	30.00	-16.80	100	224	QP
3	120.2766	28.37	-13.87	14.50	30.00	-15.50	200	358	QP
4	159.7844	27.97	-11.87	16.10	30.00	-13.90	200	360	QP
5	229.2931	27.04	-12.74	14.30	30.00	-15.70	200	59	QP
6	399.0302	31.98	-8.08	23.90	37.00	-13.10	100	213	QP
7	836.2443	66.27	0.27	66.54	N/A	N/A	100	288	TX
8	884.5030	43.24	1.16	44.40	N/A	N/A	300	230	RX

Note: TX: the transmitting signal of Universal Radio Communication Tester.

RX: the receiving signal of Universal Radio Communication Tester.

Standard:	FCC Part 15B Class B	Test Distance:	3m
Test item:	Radiated Emission	Power:	DC 3.8V
Model Number:	HE910-NAG	Temp.(°C)/Hum.(%RH):	26(°C)/60%RH
Mode:	5 (1GHz~10GHz)	Date:	04/13/2012
Ant.Polar.:	Horizontal	Test By:	Charlie Chang

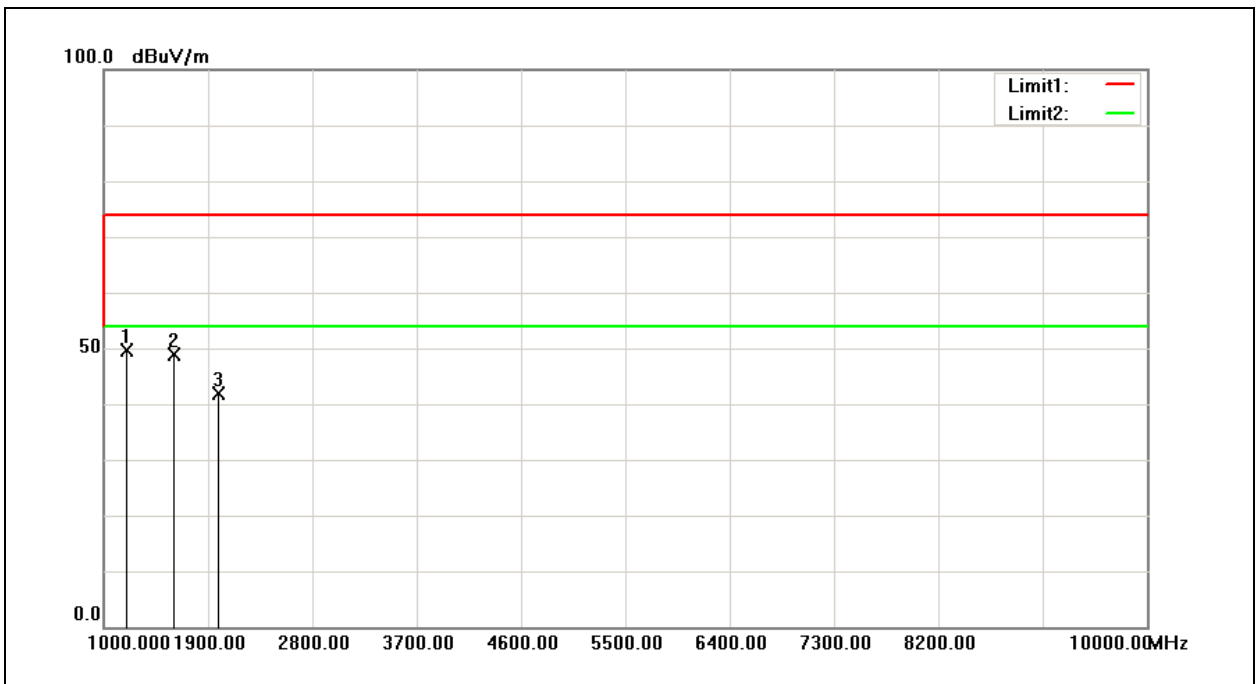

No.	Frequency (MHz)	Reading (dBuV)	Correct Factor(dB/m)	Result (dBuV/m)	Limit (dBuV/m)	Margin (dB)	Remark
1	1195.000	76.53	-26.79	49.74	74.00	-24.26	peak
2	1600.000	74.43	-25.55	48.88	74.00	-25.12	peak
3	1990.000	66.77	-24.83	41.94	74.00	-32.06	peak

Standard:	FCC Part 15B Class B	Test Distance:	3m
Test item:	Radiated Emission	Power:	DC 3.8V
Model Number:	HE910-NAG	Temp.(°C)/Hum.(%RH):	26(°C)/60%RH
Mode:	5 (1GHz~10GHz)	Date:	04/13/2012
Ant.Polar.:	Vertical	Test By:	Charlie Chang

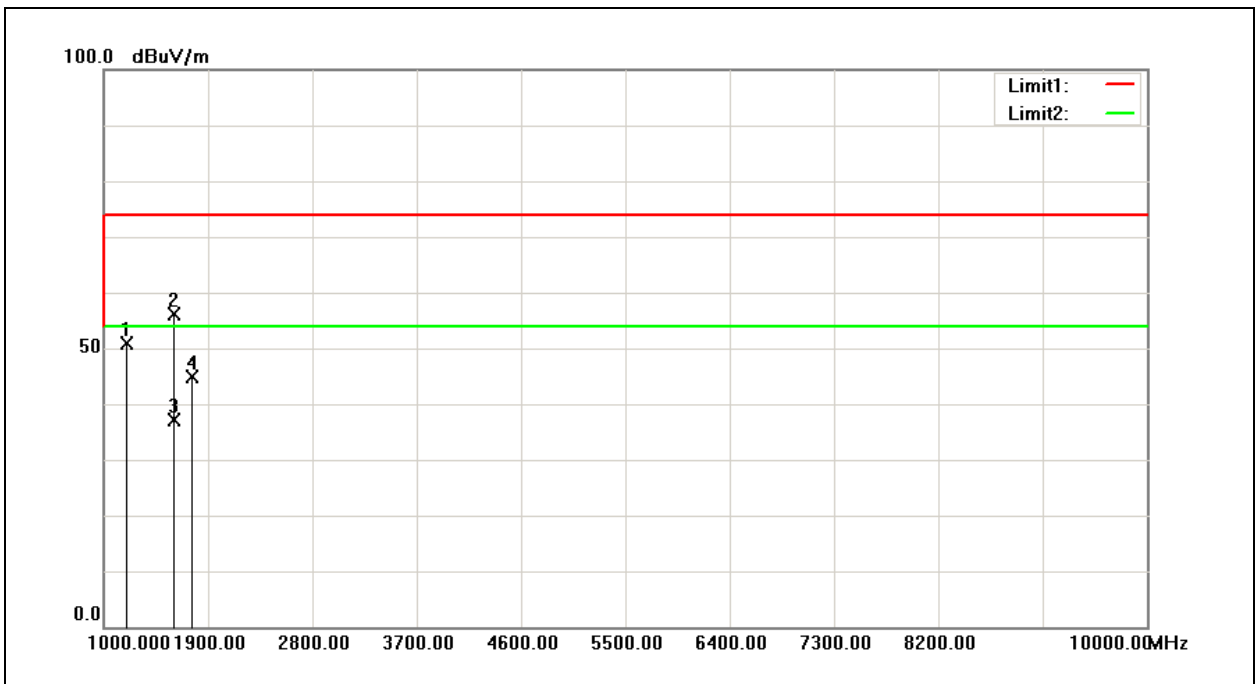

No.	Frequency (MHz)	Reading (dBuV)	Correct Factor(dB/m)	Result (dBuV/m)	Limit (dBuV/m)	Margin (dB)	Remark
1	1195.000	77.68	-26.79	50.89	74.00	-23.11	peak
2	1595.000	81.59	-25.57	56.02	74.00	-17.98	peak
3	1595.000	62.62	-25.57	37.05	54.00	-16.95	AVG
4	1755.000	70.14	-25.26	44.88	74.00	-29.12	peak