

GM862-QUAD / PY Hardware User Guide

GM862-QUAD-PY, GM862-QUAD HW User Guide
1v0300748 Rev. 1 - 24/10/06



Contents

- 1 Overview 6**
- 2 Interface connectors on GM862-QUAD / PY 7**
 - 2.1 Description 7**
 - 2.2 Connectors Position 7**
 - 2.3 Board to Board Connector 8**
 - 2.3.1 Molex 52991-0508 (male) GM862 Connector PIN-OUT 9
 - 2.3.2 Antenna Connector 11
 - 2.4 Dimensions 12**
 - 2.5 Mounting the GM862 Modules on your Board 13**
 - 2.5.1 Antenna Coaxial Cable Fixing 13
 - 2.5.2 Precautions 15
- 3 Hardware Commands 16**
 - 3.1 Turning ON the GM862-QUAD / PY 16**
 - 3.2 Turning OFF the GM862-QUAD / PY 18**
 - 3.2.1 Hardware Shutdown 18
 - 3.2.2 Hardware Unconditional Restart 19
- 4 Power Supply 21**
 - 4.1 Power Supply Requirements 21**
 - 4.2 General Design Rules 22**
 - 4.2.1 Electrical Design Guidelines 22
 - 4.2.1.1 + 5V input Source Power Supply Design Guidelines 22
 - 4.2.1.2 + 12V input Source Power Supply Design Guidelines 24
 - 4.2.1.3 Battery Source Power Supply Design Guidelines 26
 - 4.2.1.4 Battery Charge control Circuitry Design Guidelines 26
 - 4.2.2 Thermal Design Guidelines 29
 - 4.2.3 Power Supply PCB layout Guidelines 30
- 5 Serial Ports 31**
 - 5.1 Level translation 33**
 - 5.2 5V UART level translation 35**
- 6 Audio Section Overview 37**
 - 6.1 Microphone Paths Characteristic and Requirements 39**
 - 6.2 General Design Rules 42**
 - 6.3 Other Considerations 42**



GM862-QUAD / PY Hardware User Guide

1vv0300748 Rev. 1 - 24/10/06

| | | |
|------------|---|-----------|
| 6.4 | Microphone Biasing | 43 |
| 6.4.1 | Balanced Microphone Biasing | 43 |
| 6.4.2 | Unbalanced Microphone Biasing | 44 |
| 6.5 | Microphone Buffering | 46 |
| 6.5.1 | Buffered Balanced Mic..... | 46 |
| 6.5.2 | Buffered Unbalanced (Single Ended) Microphone | 48 |
| 7 | OUTPUT LINES (Speaker) | 51 |
| 7.1 | Short Description. | 51 |
| 7.2 | Output Lines Characteristics | 52 |
| 7.3 | General Design Rules | 53 |
| 7.3.1 | Noise Filtering | 53 |
| 7.4 | Handset Earphone Design | 54 |
| 7.5 | Hands-Free Earphone (Low Power) Design | 55 |
| 7.6 | Car Kit Speakerphone Design | 56 |
| 8 | General Purpose I/O | 57 |
| 8.1 | Logic level specifications | 57 |
| 8.2 | Using a GPIO pin as INPUT | 59 |
| 8.3 | Using a GPIO pin as OUTPUT | 59 |
| 8.4 | Using the RFTXMON Output GPIO5 | 59 |
| 8.5 | Using the Alarm Output GPIO6 | 59 |
| 8.6 | Using the Buzzer Output GPIO7 | 60 |
| 9 | ADC section | 61 |
| 9.1 | ADC converter | 61 |
| 9.1.1 | Description | 61 |
| 9.1.2 | Using ADC Converter | 61 |
| 10 | Camera | 62 |
| 10.1 | Camera Transchip | 62 |
| 10.1.1 | Camera Interface Connectors..... | 62 |
| 10.1.2 | EVB for Camera Support | 63 |
| 10.1.3 | EVB for Transchip camera support | 65 |
| 10.1.4 | Block Diagram for supported camera | 66 |
| 10.1.5 | Schematic Diagrams for supported cameras | 67 |
| 10.1.6 | Example usage script for camera | 68 |
| 11 | Conformity Assessment Issues | 69 |
| 12 | Document Change Log | 70 |



GM862-QUAD / PY Hardware User Guide

1v0300748 Rev. 1 - 24/10/06

This document is relating to the following products:



GM862-QUAD
Modem

GM862-QUAD-PY
Modem

| | |
|---------------|---------------|
| GM862-QUAD | 3 990 250 659 |
| GM862-QUAD-PY | 3 990 250 658 |



DISCLAIMER

The information contained in this document is proprietary information of Telit Communications S.p.A.

Telit Communications S.p.A. makes every effort to ensure the quality of the information it makes available. Notwithstanding the foregoing, Telit Communications S.p.A. does not make any warranty as to the information contained herein, and does not accept any liability for any injury, loss or damage of any kind incurred by use of or reliance upon the information.

Telit Communications S.p.A. disclaims any and all responsibility for the application of the devices characterized in this document, and notes that the application of the device must comply with the safety standards of the applicable country, and where applicable, with the relevant wiring rules.

Telit Communications S.p.A. reserves the right to make modifications, additions and deletions to this document at any time and without notice.

© 2006 Telit Communications S.p.A.



1 Overview

The aim of this document is the description of some hardware solutions useful for developing a product with the [Telit GM862-QUAD / PY module](#).

In this document all the basic functions of a mobile phone will be taken into account; for each one of them a proper hardware solution will be suggested and eventually the wrong solutions and common errors to be avoided will be evidenced. Obviously this document cannot embrace the whole hardware solutions and products that may be designed. The wrong solutions to be avoided shall be considered as mandatory, while the suggested hardware configurations shall not be considered mandatory, instead the information given shall be used as a guide and a starting point for properly developing your product with the [Telit GM862-QUAD / PY module](#). For further hardware details that may not be explained in this document refer to the Telit GM862-QUAD / PY Product Description document where all the hardware information is reported.

NOTICE

(EN) The integration of the GSM/GPRS GM862-QUAD / PY cellular module within user application shall be done according to the design rules described in this manual.

(IT) L'integrazione del modulo cellulare GSM/GPRS GM862-QUAD / PY all'interno dell'applicazione dell'utente dovrà rispettare le indicazioni progettuali descritte in questo manuale.

(DE) Die integration des GM862-QUAD / PY GSM/GPRS Mobilfunk-Moduls in ein Gerät muß gemäß der in diesem Dokument beschriebenen Konstruktionsregeln erfolgen

(SL) Integracija GSM/GPRS GM862-QUAD / PY modula v uporabniški aplikaciji bo morala upoštevati projektna navodila, opisana v tem priročniku.

(SP) La utilización del modulo GSM/GPRS GM862-QUAD / PY debe ser conforme a los usos para los cuales ha sido diseñado descritos en este manual del usuario.

(FR) L'intégration du module cellulaire GSM/GPRS GM862-QUAD / PY dans l'application de l'utilisateur sera faite selon les règles de conception décrites dans ce manuel.

(HE) האינטגרציה של המודם הסלולרי GM862-QUAD / PY עם המוצר. את ההנחיות המפורטות במסמך זה בתהליך האינטגרציה של המודם הסלולרי.

The information presented in this document is believed to be accurate and reliable. However, no responsibility is assumed by Telit Communication S.p.A. for its use, nor any infringement of patents or other rights of third parties which may result from its use. No license is granted by implication or otherwise under any patent rights of Telit Communication S.p.A. other than for circuitry embodied in Telit products. This document is subject to change without notice.



2 Interface connectors on GM862-QUAD / PY

2.1 Description

The [Telit GM862-QUAD / PY](#) is provided of the following interfaces:

- **GSM antenna connector**
- **Board To Board Interface connector**
- **SIM Card Reader**

The [Telit GM862-QUAD / PY](#) board to board connector is a CSTP 50 pin vertical SMD Molex 52991–0508 (male).

2.2 Connectors Position

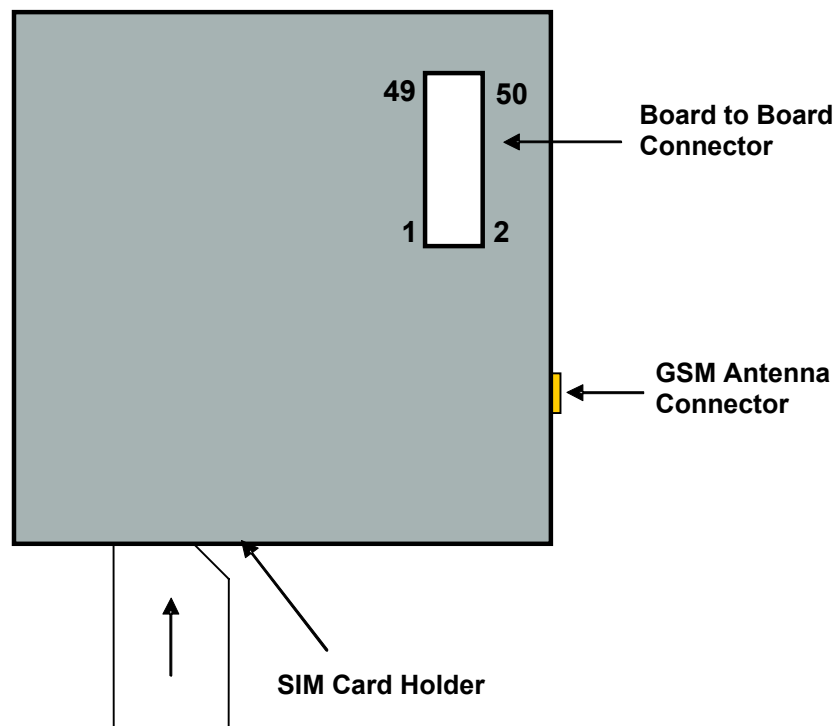

2.3 Board to Board Connector

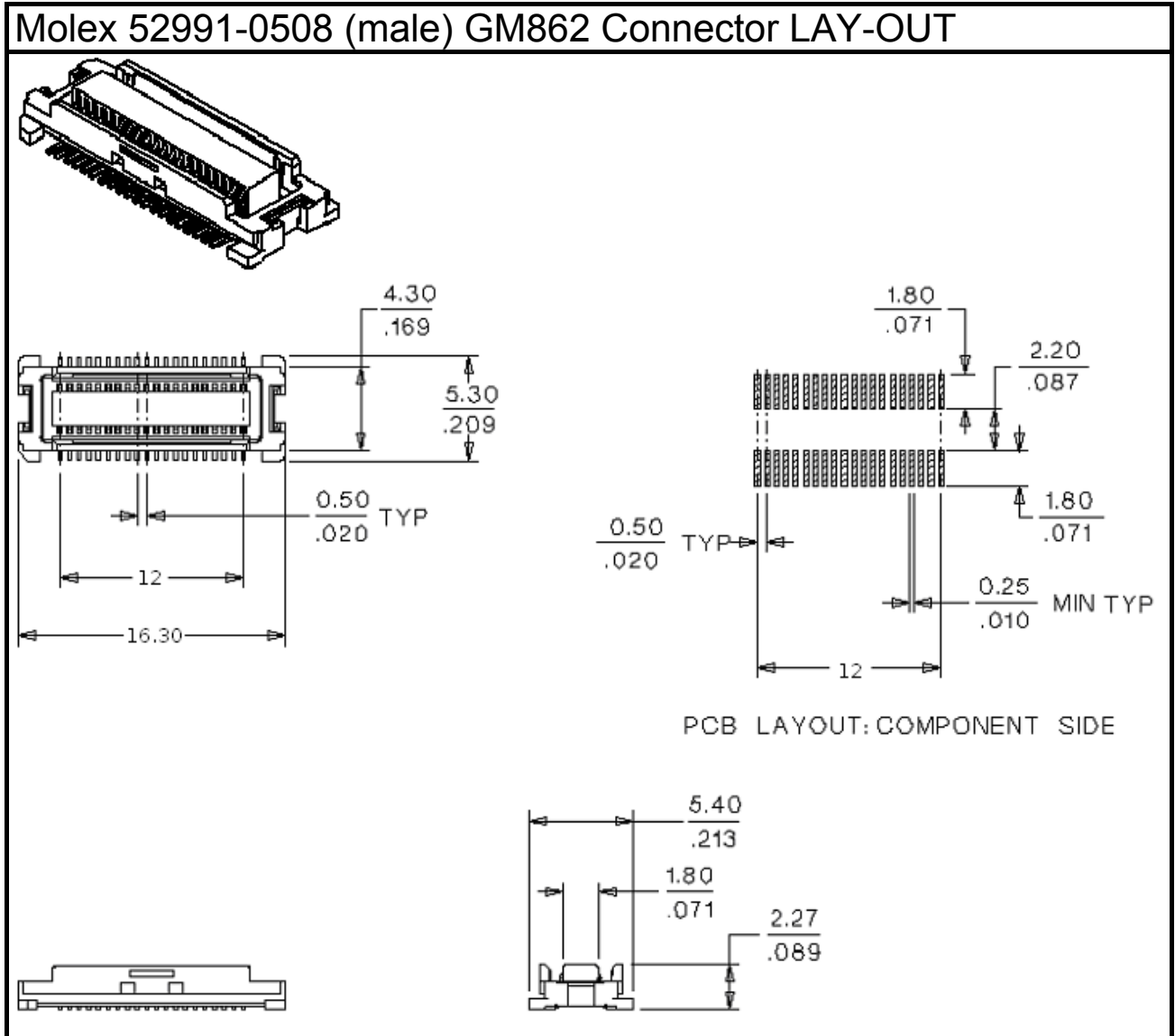

2.3.1 Molex 52991-0508 (male) GM862 Connector PIN-OUT

| Pin | Signal | I/O | Function | Internal Pull up | Type |
|-----|------------------|-----|--|------------------|------------------|
| 1 | VBATT | - | Main power supply | | Power |
| 2 | GND | - | Ground | | Power |
| 3 | VBATT | - | Main power supply | | Power |
| 4 | GND | - | Ground | | Power |
| 5 | VBATT | - | Main power supply | | Power |
| 6 | A/D | - | A/D converter @ 11 bit (Input Impedance >100Kohm) | | Max 2V input |
| 7 | VBATT | - | Main power supply | | Power |
| 8 | CHARGE | AI | Battery Charger Input | | Power |
| 9 | EAR_HF+ | AO | Handsfree ear output, phase + | | Audio |
| 10 | EAR_MT- | AO | Handset earphone signal output, phase - | | Audio |
| 11 | EAR_HF- | AO | Handsfree ear output, phase - | | Audio |
| 12 | EAR_MT+ | AO | Handset earphone signal output, phase + | | Audio |
| 13 | MIC_HF- | AI | Handsfree microphone input; phase - | | Audio |
| 14 | MIC_MT+ | AI | Handset microphone signal input; phase+ | | Audio |
| 15 | MIC_HF+ | AI | Handsfree microphone input; phase + | | Audio |
| 16 | MIC_MT- | AI | Handset microphone signal input; phase- | | Audio |
| 17 | ON_OFF | I | Input command for switching power ON or OFF (toggle command). | 47K Ω | Pull Up to VBATT |
| 18 | AXE | I | Handsfree switching | 100K Ω | CMOS 2.8V |
| 19 | SIMIO | I/O | External SIM signal - Data I/O | | 3V ONLY |
| 20 | C103/TXD | I | Serial data input (TXD) from DTE | | CMOS 2.8V |
| 21 | PWRMON | O | Module Status ON indication (Signal output for power on/off control of external devices) | 1K Ω | CMOS 2.8V |
| 22 | SIMVCC | - | External SIM signal – Power (3) | | 3V ONLY |
| 23 | RESET | I | Reset input | | |
| 24 | SIMRST | O | External SIM signal – Reset | | 3V ONLY |
| 25 | CAM_CLK | I/O | Camera Interface (4) | | CMOS 2.8V |
| 26 | SIMCLK | O | External SIM signal – Clock | | 3V ONLY |
| 27 | SIMIN | I/O | External SIM signal – Presence (active low) | 47K Ω | CMOS 2.8V |
| 28 | GPO2 / JDR | O | General purpose output (Open Collector) / Jammer Detect Report | | Open Collector |
| 29 | C106/CTS | O | Output for Clear to send signal (CTS) to DTE | | CMOS 2.8V |
| 30 | C125/RING | O | Output for Ring indicator signal (RI) to DTE | | CMOS 2.8V |
| 31 | GPI1 | I | General purpose input | | transistor base |
| 32 | GPIO8/CAM_0 N | I/O | Configurable general purpose I/O pin / Camera Interface (4) | | CMOS 2.8V |



GM862-QUAD / PY Hardware User Guide

1v0300748 Rev. 1 - 24/10/06

| Pin | Signal | I/O | Function | Internal Pull up | Type |
|-----|-----------------|-----|---|------------------|----------------|
| 33 | C107/DSR | O | Output for Data set ready signal (DSR) to DTE | | CMOS 2.8V |
| 34 | GPIO9/CAM_RST | I/O | Configurable general purpose I/O pin / Camera Interface (4) | | CMOS 2.8V |
| 35 | TX_TRACE | O | RESERVED on GM862-QUAD, Python Debug on GM862-QUAD-PY (TX data) | | CMOS 2.8V |
| 36 | C109/DCD | O | Output for Data carrier detect signal (DCD) to DTE | | CMOS 2.8V |
| 37 | C104/RXD | O | Serial data output to DTE | | CMOS 2.8V |
| 38 | GPIO10 | I/O | Configurable general purpose I/O | | CMOS 2.8V |
| 39 | STAT_LED | O | Status indicator led | | Open Collector |
| 40 | GPIO11 | I/O | Configurable general purpose I/O pin | | CMOS 2.8V |
| 41 | RX_TRACE | I | RESERVED on GM862-QUAD, Python Debug on GM862-QUAD-PY (RX data) | | CMOS 2.8V |
| 42 | GPIO12 | I/O | Configurable general purpose I/O pin | | CMOS 2.8V |
| 43 | C108/DTR | I | Input for Data terminal ready signal (DTR) from DTE (4) | | CMOS 2.8V |
| 44 | GPIO13 | I/O | Configurable general purpose I/O pin | | CMOS 2.8V |
| 45 | C105/RTS | I | Input for Request to send signal (RTS) from DTE | | CMOS 2.8V |
| 46 | GPIO3 / CAM_SCL | I/O | Configurable general purpose I/O pin / IIC Camera Interface (4) | | CMOS 2.8V |
| 47 | GPIO4 / CAM_SDA | I/O | Configurable general purpose I/O pin / IIC Camera Interface (4) | | CMOS 2.8V |
| 48 | GPIO5 / RFTXMON | I/O | Configurable general purpose I/O pin / Transmitter ON Monitor | | CMOS 2.8V |
| 49 | GPIO6 / ALARM | I/O | Configurable general purpose I/O pin / ALARM | | CMOS 2.8V |
| 50 | GPIO7 / BUZZER | I/O | Configurable general purpose I/O pin / BUZZER | | CMOS 2.8V |

- (1) For the exclusive use of the Technical Support Service
- (2) An earphone with a 150 ohm impedance can be directly connected to EAR+ and EAR-
- (3) On this pin a maximum of 10nF bypass capacitor is allowed.
- (4) When activating the Easy camera these pins will not be available for other use

Note: If not used, almost all pins should be left disconnected. The only exceptions are the following pins:

| pin | signal |
|----------------|------------------|
| 1,3,5,7 | VBATT |
| 2,4,6,8 | GND |
| 17 | ON/OFF* |
| 20 | TXD |
| 23 | RESET* |
| 37 | RXD |
| 45 | RTS ¹ |

¹ RTS should be connected to the GND (on the module side) if flow control is not used



2.3.2 Antenna Connector

The [Telit GM862-QUAD / PY](#) includes one 50 Ohm MMCX coaxial female RF connector. On the user application side the following connector must be used:

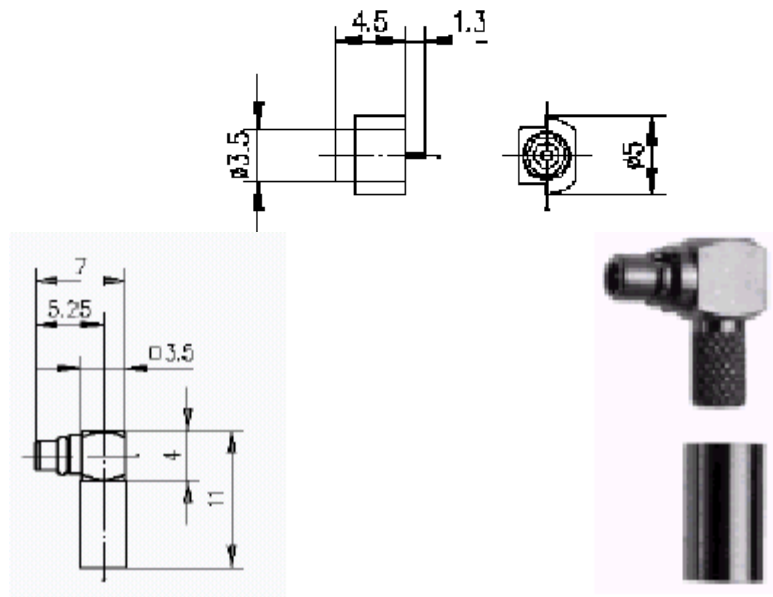

a) Telegärtner
 crimp - Order n. J01340A0121

MMCX angle plug

NOTE: be very careful when connecting the [Telit GM862 Family modules](#) RF connector. The RF connector can be damaged if not connected with the proper antenna RF connector. The minimum number of insertion cycles are recommended.



2.4 Dimensions

The **Telit GM862-QUAD / PY module** overall dimension are:

- **Length:** 43.9 mm
- **Width:** 43.9 mm
- **Thickness:** 6.9 mm
- **Volume:** $\cong 13 \text{ cm}^3$

The layout is shown in the following figure:

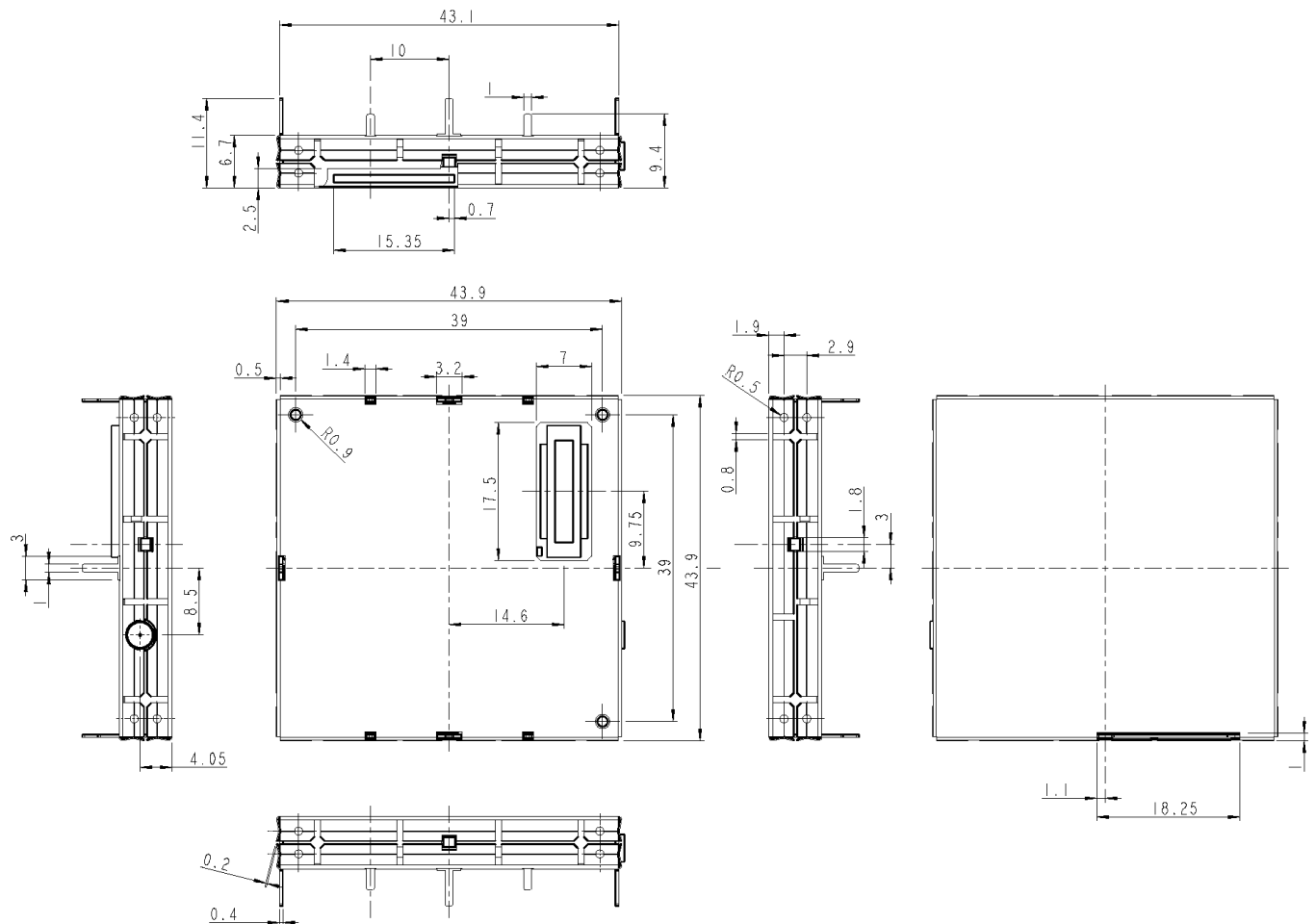

2.5 Mounting the GM862 Modules on your Board

In order to electrically connect your board to the [Telit GM862 Family modules](#), use a **CSTP 2x25 pin vertical SMD SCH–SCH Molex 53748 - 0504 (female, low profile)** as a counterpart to the **CSTP 50 pin vertical SMD Molex 52991–0508 (male)** of your [Telit GM862 Family modules](#).

When mounting the [Telit GM862 Family modules](#) on your board, take care of soldering the GM862 shielding reeds on a ground plane or signal.

NOTE: *be very careful when connecting the [Telit GM862 module](#) RF connector. The [Telit GM862 module](#) RF connector can be damaged if not connected with the proper antenna RF connector. The minimum number of insertion cycles is recommended.*

2.5.1 Antenna Coaxial Cable Fixing

The following constraints must be respected in the [Telit GM862 Family modules](#) antenna cable connection:

- The fixing point of the coaxial cable must not be placed too close to the antenna connector of the [GM862 module](#), leaving at least 30mm of flexible cable between the fixed point and the plug end.
- The fixing point must be at the same height of the [GM862 module](#) antenna connector, eventually using a wedge between the PCB and the cable if it is directly fixed to the PCB.
- The flexible cable must never be bent with a radius lower than 25mm (RG174 cable).
- The cable must be a RG174 type or more flexible ones.



The following pictures explain these constraints:

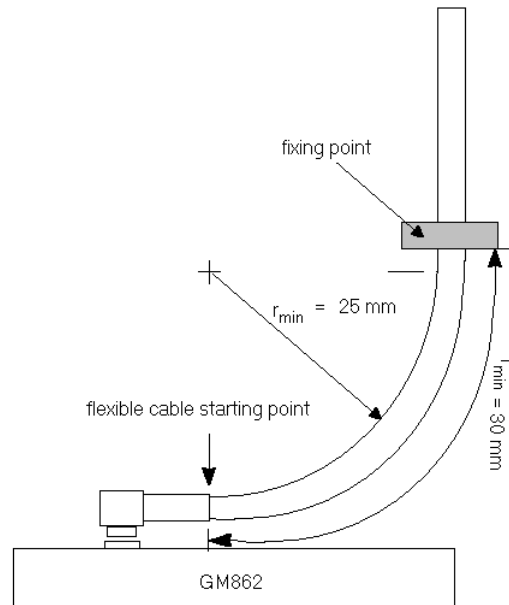

- Angle connector fixing example -

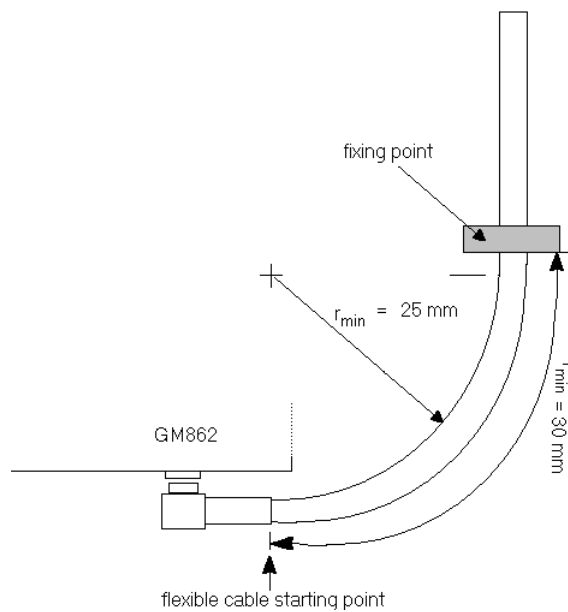

- Angle connector fixing example 2 -

NOTE: in the examples the cable is always bent, this is not a constrain. If the installation does not require it, then the cable can be kept straight, ensuring that the fixing is without sliding.



2.5.2 Precautions

- The plug should be inserted in the connector only after the installation of the [Telit GM862 Family modules](#) in the board. This is to prevent accidental breaking of the antenna connection during the transport.
- The coaxial cable must be fixed at least in one point, without sliding possibilities.
- The plug insertion/removal must be done axially with the female connector of the GM862, keeping lateral strains to a minimum.
- The insertion/crimping pull out force must be less than 15N.



3 Hardware Commands

3.1 Turning ON the GM862-QUAD / PY

To turn on the GM862-QUAD / PY the pin ON# must be tied low for at least 1 second and then released.

The maximum current that can be drained from the ON# pin is 0,1 mA.

A simple circuit to do it is:

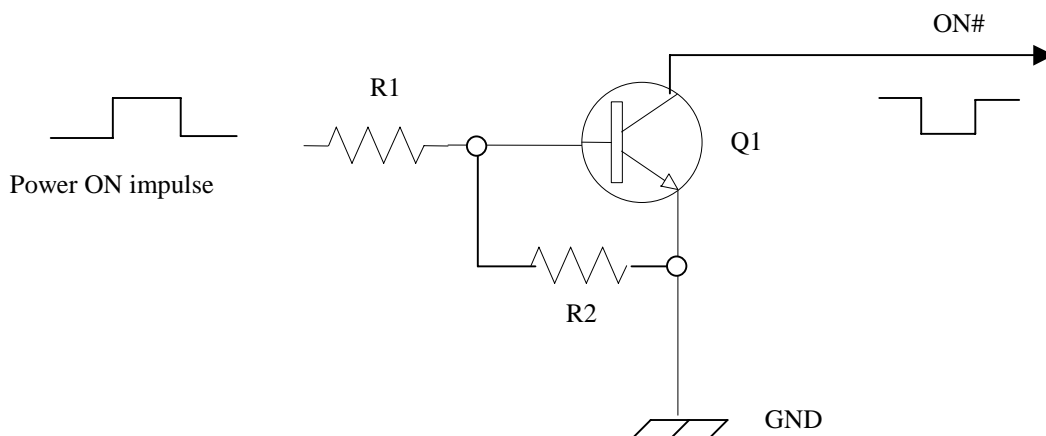

NOTE: don't use any pull up resistor on the ON# line, it is internally pulled up. Using pull up resistor may bring to latch up problems on the GM862-QUAD / PY power regulator and improper power on/off of the module. The line ON# must be connected only in open collector configuration.

NOTE: In this document all the lines that are inverted, hence have active low signals are labelled with a name that ends with a "#" or with a bar over the name.

TIP: To check if power has raised it is possible to monitor the PWRMON line, when this line goes high the module is powered on, but before it remains on the device needs other 900 ms for software startup. Hence check the PWRMON line and 900 ms after its transition to high it is possible to release the ON# pin.



GM862-QUAD / PY Hardware User Guide

1v0300748 Rev. 1 - 24/10/06

For example:

1- Let's assume you need to drive the ON# pin with a totem pole output of a +3/5 V microcontroller (uP_OUT1):

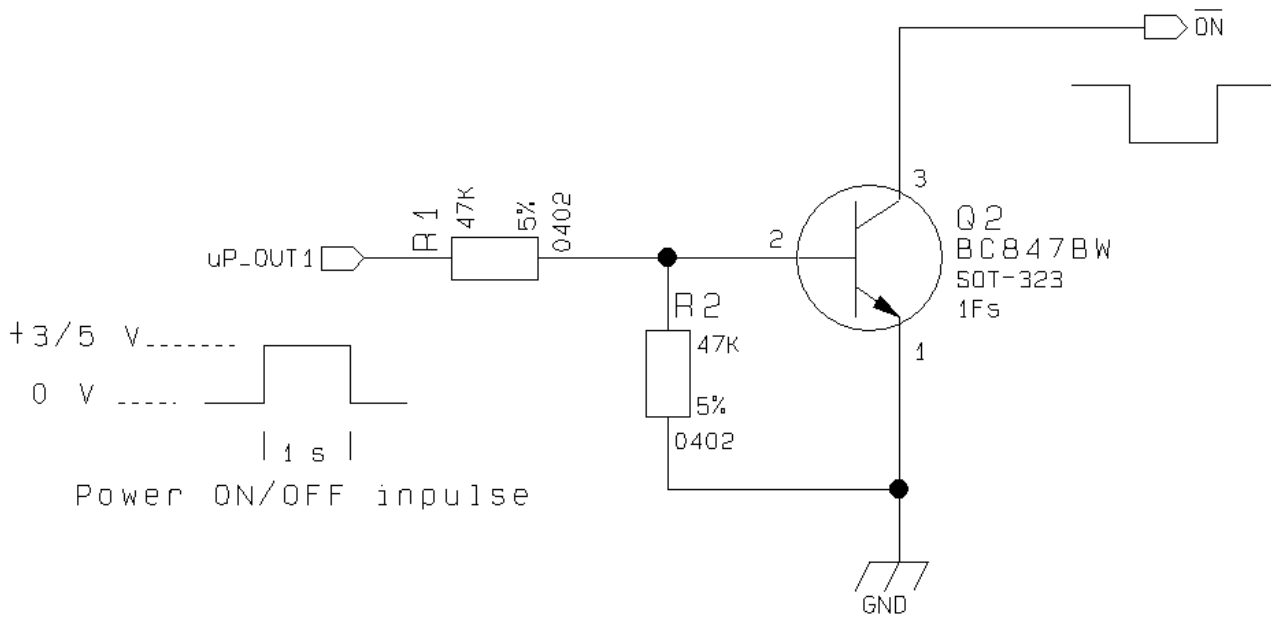

2- Let's assume you need to drive the ON# pin directly with an ON/OFF button:

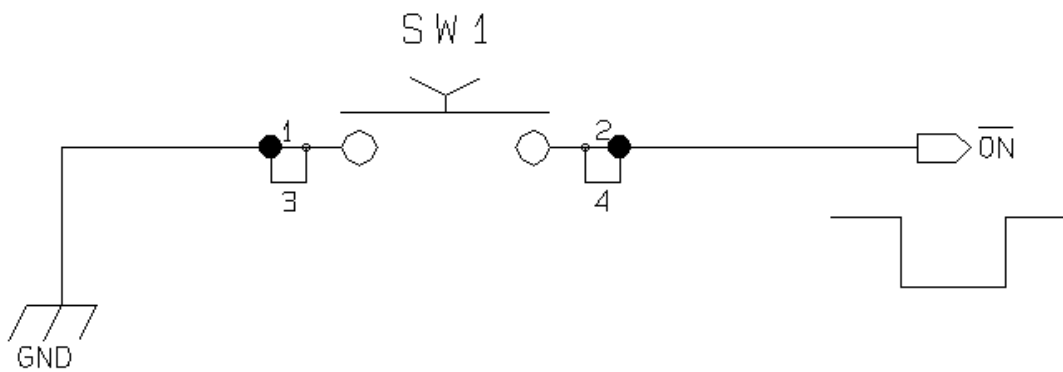

3.2 Turning OFF the GM862-QUAD / PY

The turning off of the device can be done in two ways:

- by software command (see GM862-QUAD / PY Software User Guide)
- by hardware shutdown
- by hardware unconditional shutdown

When the device is shut down by software command or by hardware shutdown, it issues to the network a detach request that informs the network that the device will not be reachable any more. The hardware unconditional shutdown does not issue this request and shuts down immediately the device.

3.2.1 Hardware Shutdown

To turn OFF the GM862-QUAD / PY the pin ON# must be tied low for at least 1 second and then released.

The same circuitry and timing for the power on shall be used.

The device shuts down after the release of the ON# pin.



TIP: To check if the device has powered off, the hardware line PWRMON should be monitored. When PWRMON goes low, the device has powered off.



3.2.2 Hardware Unconditional Restart

To unconditionally Shutdown the GM862-QUAD / PY the pin RESET# must be tied low for at least 200 milliseconds and then released.

The maximum current that can be drained from the RESET# pin is 0,15 mA.

A simple circuit to do it is:

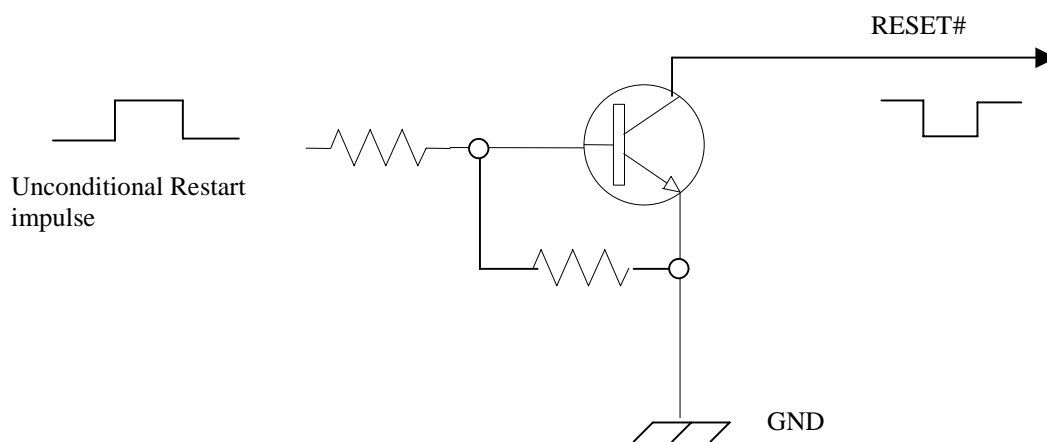

NOTE: don't use any pull up resistor on the RESET# line nor any totem pole digital output. Using pull up resistor may bring to latch up problems on the GM862-QUAD / PY power regulator and improper functioning of the module. The line RESET# must be connected only in open collector configuration.



TIP: The unconditional hardware Restart should be always implemented on the boards and software should use it as an emergency exit procedure.



For example:

1- Let's assume you need to drive the RESET# pin with a totem pole output of a +3/5 V microcontroller (uP_OUT2):

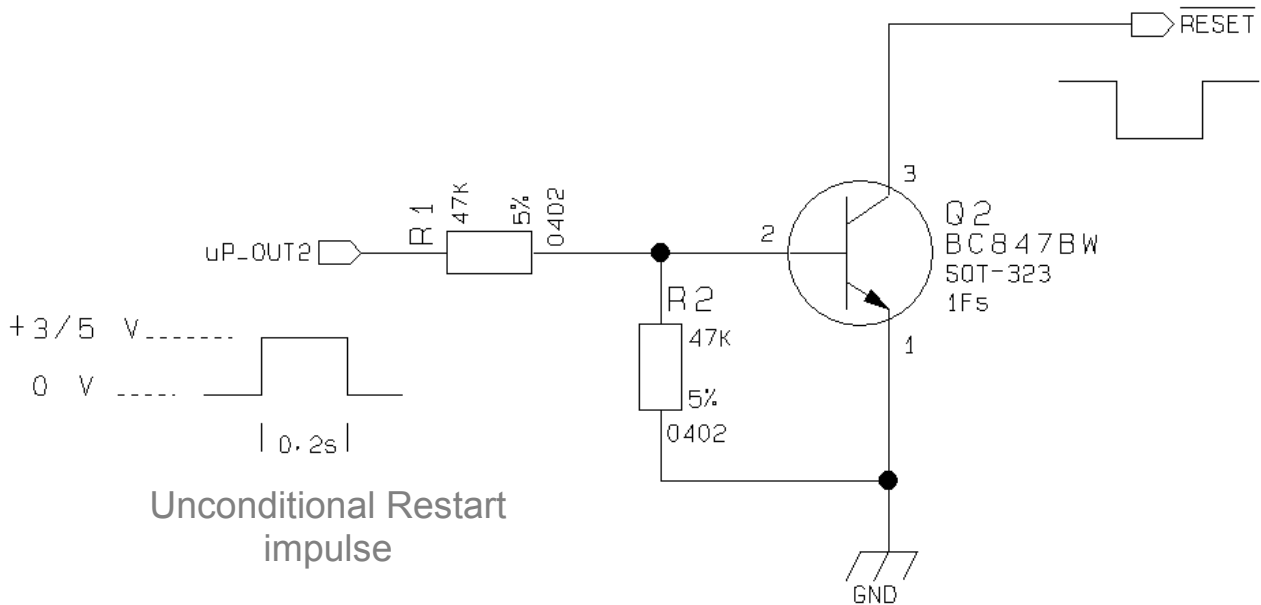

The hardware unconditional restart must not be used during normal operation of the device since it does not detach the device from the network. It shall be kept as an emergency exit procedure to be done in the rare case that the device gets stacked waiting for some network or SIM responses. If device does not respond to a command in the timeout window, retry issuing the command and if still no response is received a hardware reset shall be issued.

Reset Signal Operating levels:

| Signal | Min | Max |
|------------------|-------|------|
| RESET Input high | 2.0V* | 2.2V |
| RESET Input low | 0V | 0.2V |

* this signal is internally pulled up so the pin can be left floating if not used.



4 Power Supply

The power supply circuitry and board layout are the most important part in the full product design and they strongly reflect on the product overall performances, hence read carefully the requirements and the guidelines that will follow for a proper design.

4.1 Power Supply Requirements

The GM862-QUAD / PY power requirements are:

- *Nominal Supply Voltage:* 3.8 V
- *Max Supply Voltage:* 4.2 V
- *Supply voltage range:* 3.4 V - 4.2 V
- *Max Peak current consumption (impulsive):* 1.9 A
- *Max Average current consumption during GPRS transmission :* 500 mA
- *Max Average current consumption during VOICE/CSD transmission :* 270 mA
- *Average current during Power Saving:* ≈ 4 mA
- *Average current during idle (Power Saving disabled)* ≈ 19 mA

The GSM system is made in a way that the RF transmission is not continuous, else it is packed into bursts at a base frequency of about 216 Hz, the relative current peaks can be as high as about 2A. Therefore the power supply has to be designed in order to withstand with these current peaks without big voltage drops; this means that both the electrical design and the board layout must be designed for this current flow.

If the layout of the PCB is not well designed a strong noise floor is generated on the ground and the supply; this will reflect on all the audio paths producing an audible annoying noise at 216 Hz; if the voltage drop during the peak current absorption is too much, then the device may even shutdown as a consequence of the supply voltage drop.



TIP: The electrical design for the Power supply should be made ensuring it will be capable of a peak current output of at least 2 A.



4.2 General Design Rules

The principal guidelines for the Power Supply Design embrace three different design steps:

- the electrical design
- the thermal design.
- the PCB layout.

4.2.1 Electrical Design Guidelines

The electrical design of the power supply depends strongly from the power source where this power is drained. We will distinguish them into three categories:

- +5V input (typically PC internal regulator output)
- +12V input (typically automotive)
- Battery

4.2.1.1 + 5V input Source Power Supply Design Guidelines

- The desired output for the power supply is 3.8V, hence there's not a big difference between the input source and the desired output and a linear regulator can be used. A switching power supply will not be suited because of the low drop out requirements.
- When using a linear regulator, a proper heat sink shall be provided in order to dissipate the power generated.
- A Bypass low ESR capacitor of adequate capacity must be provided in order to cut the current absorption peaks close to the GM862-QUAD / PY, a 100 μ F tantalum capacitor is usually suited.
- Make sure the low ESR capacitor on the power supply output (usually a tantalum one) is rated at least 10V.
- A protection diode should be inserted close to the power input, in order to save the GM862-QUAD / PY from power polarity inversion.



An example of linear regulator with 5V input is:

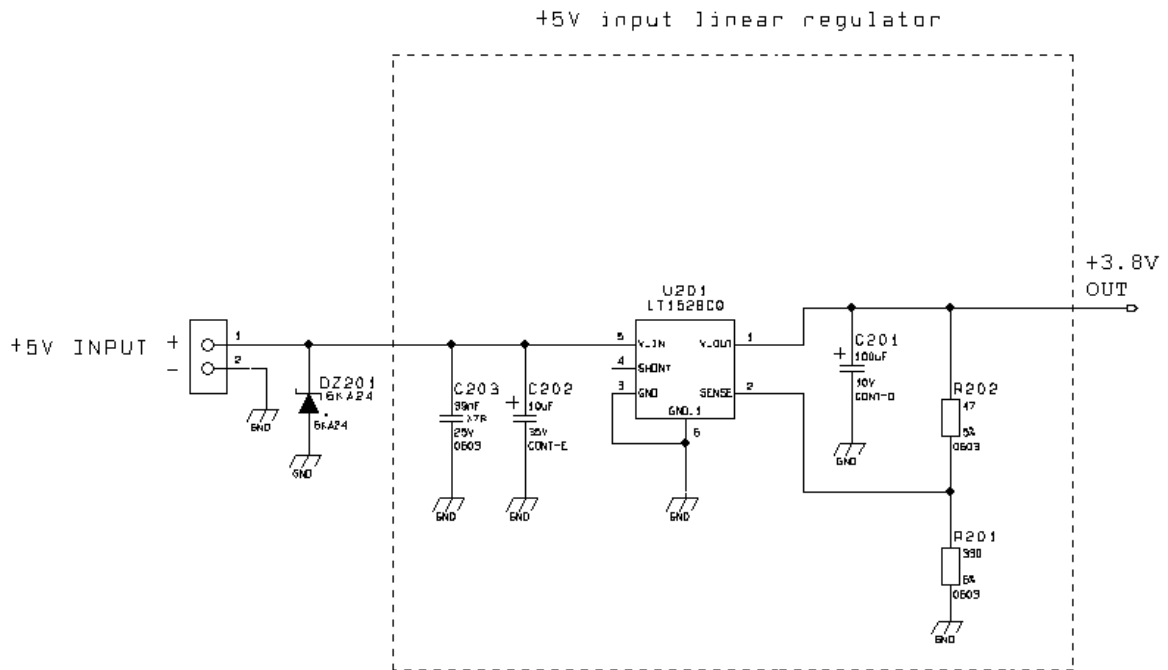

4.2.1.2 + 12V input Source Power Supply Design Guidelines

- The desired output for the power supply is 3.8V, hence due to the big difference between the input source and the desired output, a linear regulator is not suited and shall not be used. A switching power supply will be preferable because of its better efficiency especially with the 2A peak current load represented by the GM862-QUAD / PY.
- When using a switching regulator, a 500Khz switching frequency regulator is preferable because of its smaller inductor size and its faster transient response. This allows the regulator to respond quickly to the current peaks absorption.
- For car PB battery the input voltage can rise up to 15,8V and this should be kept in mind when choosing components: all components in the power supply must withstand this voltage.
- A Bypass low ESR capacitor of adequate capacity must be provided in order to cut the current absorption peaks, a 100 μ F tantalum capacitor is usually suited.
- Make sure the low ESR capacitor on the power supply output (usually a tantalum one) is rated at least 10V.
- For Car applications a spike protection diode should be inserted close to the power input, in order to clean the supply from spikes.
- A protection diode should be inserted close to the power input, in order to save the GM862-QUAD / PY from power polarity inversion. This can be the same diode as for spike protection.



GM862-QUAD / PY Hardware User Guide

1v0300748 Rev. 1 - 24/10/06

An example of switching regulator with 12V input is in the below schematic (it is split in 2 parts):

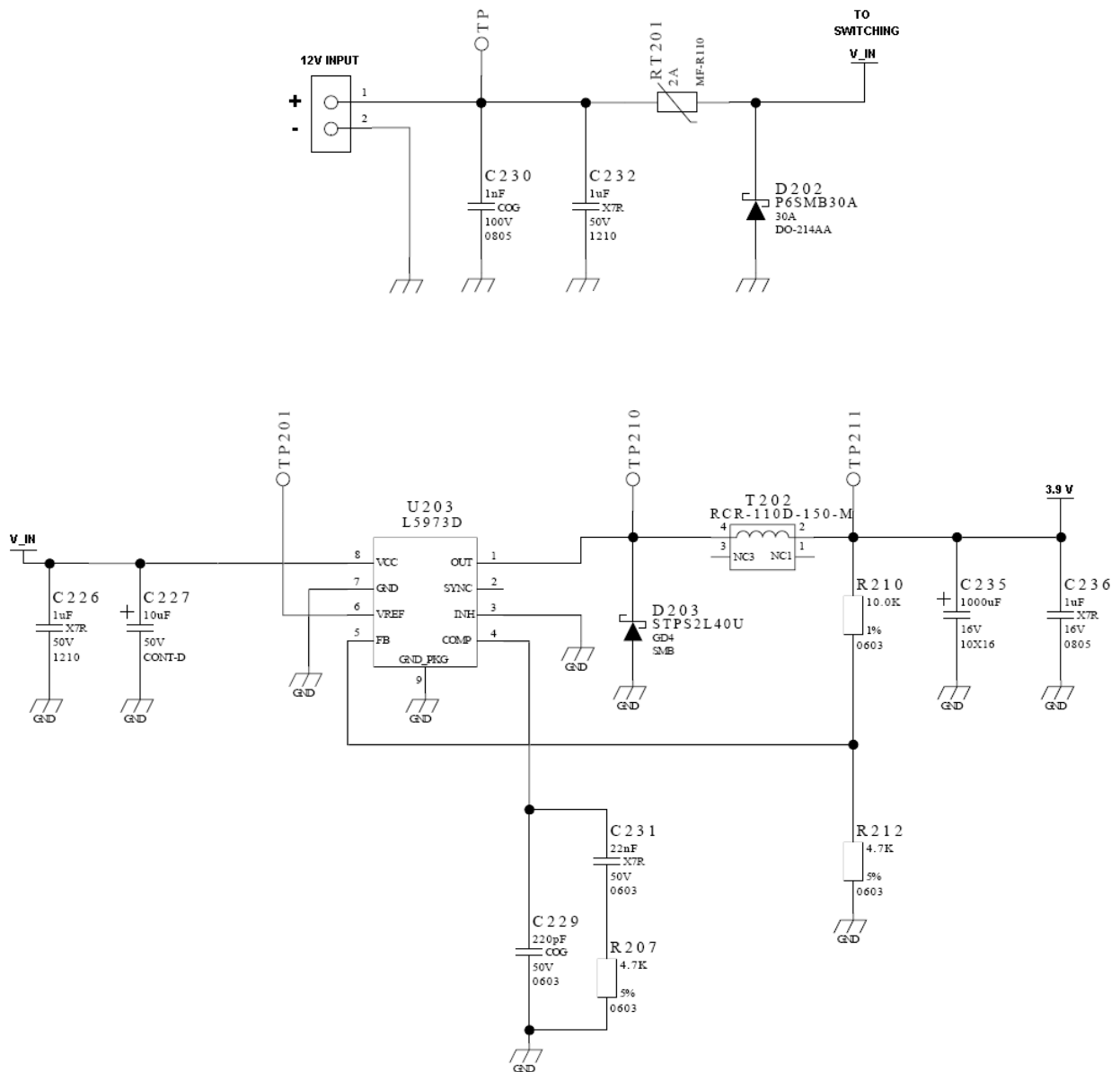

SWITCHING REGULATOR



4.2.1.3 Battery Source Power Supply Design Guidelines

- The desired nominal output for the power supply is 3.8V and the maximum voltage allowed is 4.2V, hence a single 3.7V Li-Ion cell battery type is suited for supplying the power to the Telit GM862-QUAD / PY module.
The three cells Ni/Cd or Ni/MH 3,6 V Nom. battery types or 4V PB types **MUST NOT BE USED** since their maximum voltage can rise over the absolute maximum voltage for the GM862-QUAD / PY and damage it.



NOTE: DON'T USE any Ni-Cd, Ni-MH, and Pb battery types. Their use can lead to overvoltage on the GM862-QUAD / PY and damage it. USE ONLY Rechargeable Li-Ion battery types.

- A Bypass low ESR capacitor of adequate capacity must be provided in order to cut the current absorption peaks, a 100µF tantalum capacitor is usually suited.
- Make sure the low ESR capacitor (usually a tantalum one) is rated at least 10V.
- A protection diode should be inserted close to the power input, in order to save the GM862-QUAD / PY from power polarity inversion. Otherwise the battery connector should be done in a way to avoid polarity inversions when connecting the battery.
- The battery capacity must be at least 500mAh in order to withstand the current peaks of 2A; the suggested capacity is from 500mAh to 1000mAh.

4.2.1.4 Battery Charge control Circuitry Design Guidelines

The charging process for Li-Ion Batteries can be divided into 4 phases:

- Qualification and trickle charging
- Fast charge 1 - constant current
- Final charge - constant voltage or pulsed charging
- Maintenance charge

The qualification process consists in a battery voltage measure, indicating roughly its charge status. If the battery is deeply discharged, that means its voltage is lower than the trickle charging threshold, then the charge must start slowly possibly with a current limited pre-charging process where the current is kept very low with respect to the fast charge value: the trickle charging.

During the trickle charging the voltage across the battery terminals rises; when it reaches the fast charge threshold level the charging process goes into fast charge phase.

During the fast charge phase the process proceeds with a current limited charging; this current limit depends on the required time for the complete charge and from the battery pack capacity. During this phase the voltage across the battery terminals still raises but at a lower rate.

Once the battery voltage reaches its maximum voltage then the process goes into its third state: Final charging. The voltage measure to change the process status into final charge is very important. It must be ensured that the maximum battery voltage is never exceeded, otherwise the battery may be damaged and even explode. Moreover for the constant voltage final chargers, the constant voltage phase (final charge) must not start before the battery voltage has reached its maximum value, otherwise the battery capacity will be highly reduced.

The final charge can be of two different types: constant voltage or pulsed.



GM862-QUAD / PY Hardware User Guide

1v0300748 Rev. 1 - 24/10/06

The constant voltage charge proceeds with a fixed voltage regulator (very accurately set to the maximum battery voltage) and hence the current will decrease while the battery is becoming charged. When the charging current falls below a certain fraction of the fast charge current value, then the battery is considered fully charged, the final charge stops and eventually starts the maintenance.

The pulsed charge process has no voltage regulation, instead the charge continues with pulses. Usually the pulse charge works in the following manner: the charge is stopped for some time, let's say few hundreds of ms, then the battery voltage will be measured and when it drops below its maximum value a fixed time length charging pulse is issued. As the battery approaches its full charge the off time will become longer, hence the duty-cycle of the pulses will decrease. The battery is considered fully charged when the pulse duty-cycle is less than a threshold value, typically 10%, the pulse charge stops and eventually the maintenance starts.

The last phase is not properly a charging phase, since the battery at this point is fully charged and the process may stop after the final charge. The maintenance charge provides an additional charging process to compensate for the charge leak typical of a Li-Ion battery. It is done by issuing pulses with a fixed time length, again few hundreds of ms, and a duty-cycle around 5% or less.

This last phase is not implemented in the GM862-QUAD / PY internal charging algorithm, so that the battery once charged is left discharging down to a certain threshold so that it is cycled from full charge to slight discharge even if the battery charger is always inserted. This guarantees that anyway the remaining charge in the battery is a good percentage and that the battery is not damaged by keeping it always fully charged (Li-Ion rechargeable battery usually deteriorate when kept fully charged).

Last but not least, in some applications it is highly desired that the charging process restarts when the battery is discharged and its voltage drops below a certain threshold, GM862-QUAD / PY internal charger does it.

As you can see, the charging process is not a trivial task to be done; moreover all these operations should start only if battery temperature is inside a charging range, usually 5°C - 45°C.

The GM862-QUAD / PY measures the temperature of its internal component, in order to satisfy this last requirement, it's not exactly the same as the battery temperature but in common application the two temperature should not differ too much and the charging temperature range should be guaranteed.



An example of battery charger can be:

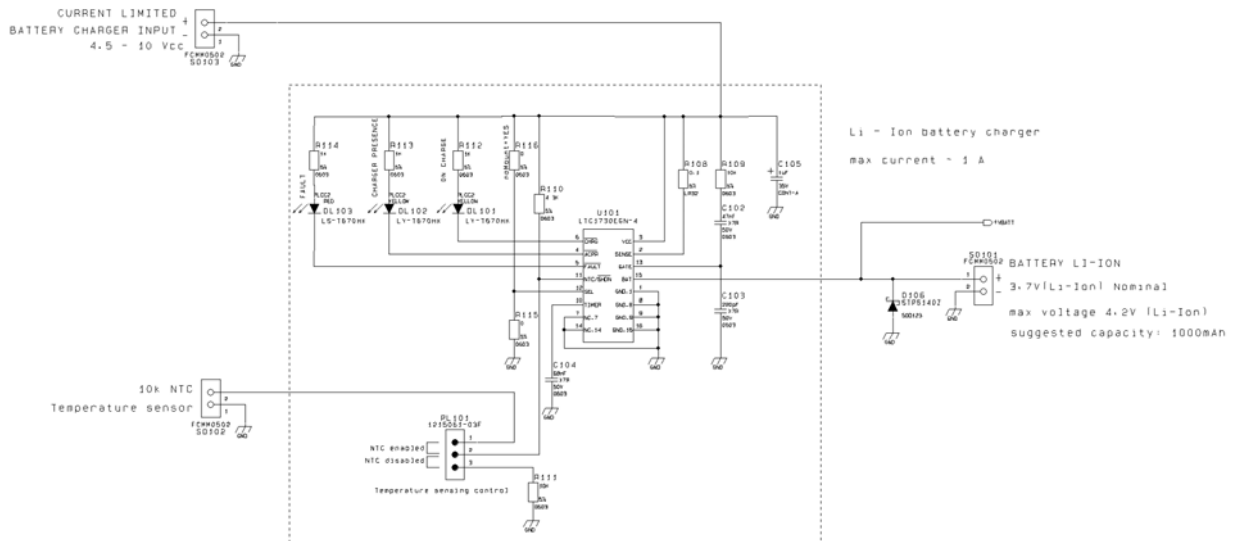

NOTE: In this particular application the battery charger input current must be limited to less than 1A. Using a current limited wall adapter as the power source can do this.

For your convenience in the EVK there's also a current unlimited input, where the input source is not limited in current and the drawn current is limited to about 0,5A by a MOSFET in the EVK.

The external battery charger is suggested in applications where the total consumption is higher than the current provided by the GM862-QUAD / PY module.



4.2.2 Thermal Design Guidelines

The thermal design for the power supply heat sink should be done with the following specifications:

- Average current consumption during transmission @PWR level max: 500mA
- Average current consumption during transmission @ PWR level min: 100mA
- Average current during Power Saving: 4mA
- Average current during idle (Power Saving disabled) 19mA



NOTE: *The average consumption during transmissions depends on the power level at which the device is requested to transmit by the network. The average current consumption hence varies significantly.*



TIP: *The thermal design for the Power supply should be made keeping a average consumption at the max transmitting level during calls of 500mA.*

Considering the very low current during idle, especially if Power Saving function is enabled, it is possible to consider from the thermal point of view that the device absorbs current significantly only during calls.

If we assume that the device stays into transmission for short periods of time (let's say few minutes) and then remains for a quite long time in idle (let's say one hour), then the power supply has always the time to cool down between the calls and the heat sink could be smaller than the calculated one for 500mA maximum current, or even could be the simple chip package (no heat sink).

Moreover in the average network conditions the device is requested to transmit at a lower power level than the maximum and hence the current consumption will be less than the 500mA, being usually around 150mA.

For these reasons the thermal design is rarely a concern and the simple ground plane where the power supply chip is placed can be enough to ensure a good thermal condition and avoid overheating.



4.2.3 Power Supply PCB layout Guidelines

As seen on the electrical design guidelines the power supply shall have a low ESR capacitor on the output to cut the current peaks and a protection diode on the input to protect the supply from spikes and polarity inversion. The placement of these components is crucial for the correct working of the circuitry. A misplaced component can be useless or can even decrease the power supply performances.

- The Bypass low ESR capacitor must be placed close to the Telit GM862-QUAD / PY power input pins or in the case the power supply is a switching type it can be placed close to the inductor to cut the ripple provided the PCB trace from the capacitor to the GM862-QUAD / PY is wide enough to ensure a dropless connection even during the 2A current peaks.
- The protection diode must be placed close to the input connector where the power source is drained.
- The PCB traces from the input connector to the power regulator IC must be wide enough to ensure no voltage drops occur when the 2A current peaks are absorbed. Note that this is not made in order to save power loss but especially to avoid the voltage drops on the power line at the current peaks frequency of 216 Hz that will reflect on all the components connected to that supply, introducing the noise floor at the burst base frequency. For this reason while a voltage drop of 300-400 mV may be acceptable from the power loss point of view, the same voltage drop may not be acceptable from the noise point of view. If your application doesn't have audio interface but only uses the data feature of the Telit GM862-QUAD / PY, then this noise is not so disturbing and power supply layout design can be more forgiving.
- The PCB traces to the GM862-QUAD / PY and the Bypass capacitor must be wide enough to ensure no voltage drops occur when the 2A current peaks are absorbed. This is for the same reason as previous point. Try to keep this trace as short as possible.
- The PCB traces connecting the Switching output to the inductor and the switching diode must be kept as short as possible by placing the inductor and the diode very close to the power switching IC (only for switching power supply). This is done in order to reduce the radiated field (noise) at the switching frequency (100-500 kHz usually).
- The use of a good common ground plane is suggested.
- The placement of the power supply on the board should be done in such a way to guarantee that the high current return paths in the ground plane are not overlapped to any noise sensitive circuitry as the microphone amplifier/buffer or earphone amplifier.
- The power supply input cables should be kept separate from noise sensitive lines such as microphone/earphone cables.



5 Serial Ports

The serial port on the Telit GM862-QUAD / PY is the core of the interface between the module and OEM hardware.

2 serial ports are available on the module:

- MODEM SERIAL PORT
- TRACE (Usable only on GM862-QUAD-PY for Python Debug)

Several configurations can be designed for the serial port on the OEM hardware, but the most common are:

- RS232 PC com port
- microcontroller UART @ 2.8V - 3V (Universal Asynchronous Receive Transmit)
- microcontroller UART@ 5V or other voltages different from 2.8V

Depending from the type of serial port on the OEM hardware a level translator circuit may be needed to make the system work. The only configuration that doesn't need a level translation is the 2.8V UART.

The TRACE Serial Port is a 3 wire (RX, TX GND) +2.8V UART.

The MODEM serial port on the GM862-QUAD / PY is a +2.8V UART with all the 7 RS232 signals. It differs from the PC-RS232 in the signal polarity (RS232 is reversed) and levels. The levels for the GM862-QUAD / PY UART are the CMOS levels:

Absolute Maximum Ratings -Not Functional

| Parameter | Min | Max |
|--|-------|--------|
| Input level on any digital pin when on | -0.3V | +3.75V |
| Input voltage on analog pins when on | -0.3V | +3.0 V |

Operating Range - Interface levels (2.8V CMOS)

| Level | Min | Max |
|----------------------------|------|-------|
| Input high level V_{IH} | 2.1V | 3.3V |
| Input low level V_{IL} | 0V | 0.5V |
| Output high level V_{OH} | 2.2V | 3.0V |
| Output low level V_{OL} | 0V | 0.35V |



GM862-QUAD / PY Hardware User Guide

1v0300748 Rev. 1 - 24/10/06

The signals of the GM862-QUAD / PY MODEM serial port are:

| RS232 Pin Number | Signal | GM862-QUAD / PY Pin Number | Name | Usage |
|------------------|----------------|----------------------------|-------------------------|--|
| 1 | DCD - dcd_uart | 36 | Data Carrier Detect | Output from the GM862-QUAD / PY that indicates the carrier presence |
| 2 | RXD - tx_uart | 37 | Transmit line *see Note | Output transmit line of GM862-QUAD / PY UART |
| 3 | TXD - rx_uart | 20 | Receive line *see Note | Input receive of the GM862-QUAD / PY UART |
| 4 | DTR - dtr_uart | 43 | Data Terminal Ready | Input to the GM862-QUAD / PY that controls the DTE READY condition |
| 5 | GND | 2-4 | Ground | Ground |
| 6 | DSR - dsr_uart | 33 | Data Set Ready | Output from the GM862-QUAD / PY that indicates the module is ready |
| 7 | RTS - rts_uart | 45 | Request to Send | Input to the GM862-QUAD / PY that controls the Hardware flow control |
| 8 | CTS - cts_uart | 29 | Clear to Send | Output from the GM862-QUAD / PY that controls the Hardware flow control |
| 9 | RI - ri_uart | 30 | Ring Indicator | Output from the GM862-QUAD / PY that indicates the incoming call condition |

 **NOTE:** According to V.24, RX/TX signal names are referred to the application side, therefore on the GM862-QUAD / PY side these signal are on the opposite direction: TXD on the application side will be connected to the receive line (here named TXD/ rx_uart) of the GM862-QUAD / PY serial port and vice versa for RX.

 **TIP:** For a minimum implementation, only the TXD and RXD lines can be connected, the other lines can be left open provided a software flow control is implemented.

The signals of the TRACE serial port are:

| Signal | GM862-QUAD / PY Pin Number | Name | Usage |
|----------|----------------------------|----------------------------|---|
| RX_TRACE | 41 | Python Debug Receive line | Input line of Python Debug serial Port |
| TX_TRACE | 35 | Python Debug Transmit line | Output line of Python Debug serial Port |
| GND | 2-4 | Ground | Ground |

5.1 Level translation

In order to interface the Telit GM862-QUAD / PY with a PC com port or a RS232 (EIA/TIA-232) application a level translator is required. This level translator must

- invert the electrical signal in both directions
- change the level from 0/3V to +15/-15V

Actually, the RS232 UART 16450, 16550, 16650 & 16750 chipsets accept signals with lower levels on the RS232 side (EIA/TIA-562) , allowing for a lower voltage-multiplying ratio on the level translator. Note that the negative signal voltage must be less than 0V and hence some sort of level translation is always required.

The simplest way to translate the levels and invert the signal is by using a single chip level translator. There are a multitude of them, differing in the number of driver and receiver and in the levels (be sure to get a true RS232 level translator not a RS485 or other standards).

By convention the driver is the level translator from the 0-3V UART level to the RS232 level, while the receiver is the translator from RS232 level to 0-3V UART.

In order to translate the whole set of control lines of the UART you will need:

- 5 driver
- 3 receiver



NOTE: The digital input lines working at 2.8VCMOS have an absolute maximum input voltage of 3,75V; therefore the level translator IC shall not be powered by the +3.8V supply of the module. Instead it shall be powered from a +2.8V / +3.0V (dedicated) power supply.

This is because in this way the level translator IC outputs on the module side (i.e. GM862-QUAD / PY inputs) will work at +3.8V interface levels, stressing the module inputs at its maximum input voltage.

This can be acceptable for evaluation purposes, but not on production devices.



GM862-QUAD / PY Hardware User Guide

1v0300748 Rev. 1 - 24/10/06

An example of level translation circuitry of this kind is:

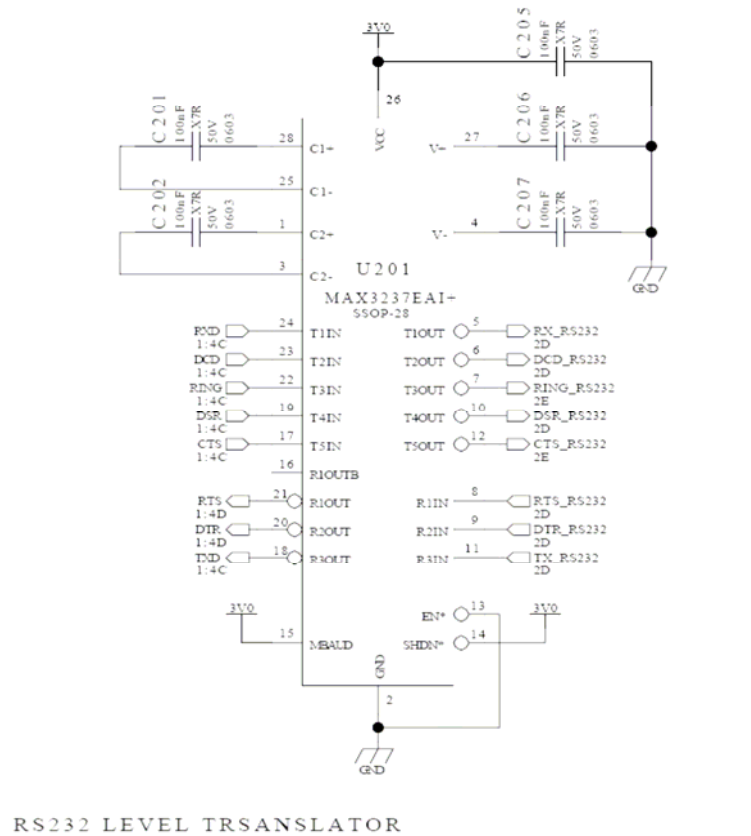

the RS232 serial port lines are usually connected to a DB9 connector with the following layout:

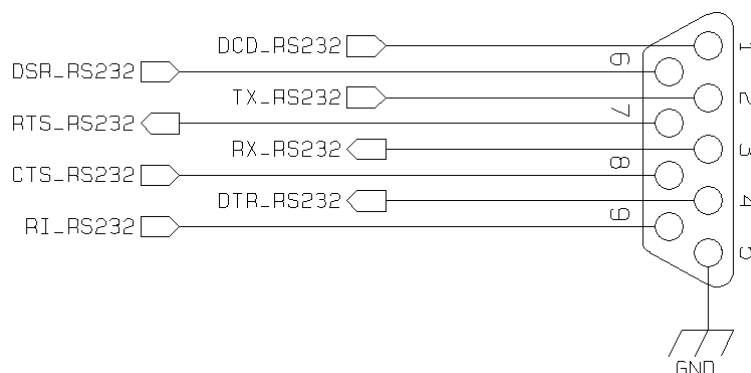

5.2 5V UART level translation

If the OEM application uses a microcontroller with a serial port (UART) that works at a voltage different from 2.8 - 3V, then a circuitry has to be provided to adapt the different levels of the two set of signals. As for the RS232 translation there are a multitude of single chip translators. For example a possible translator circuit for a 5V TRANSMITTER/RECEIVER can be:

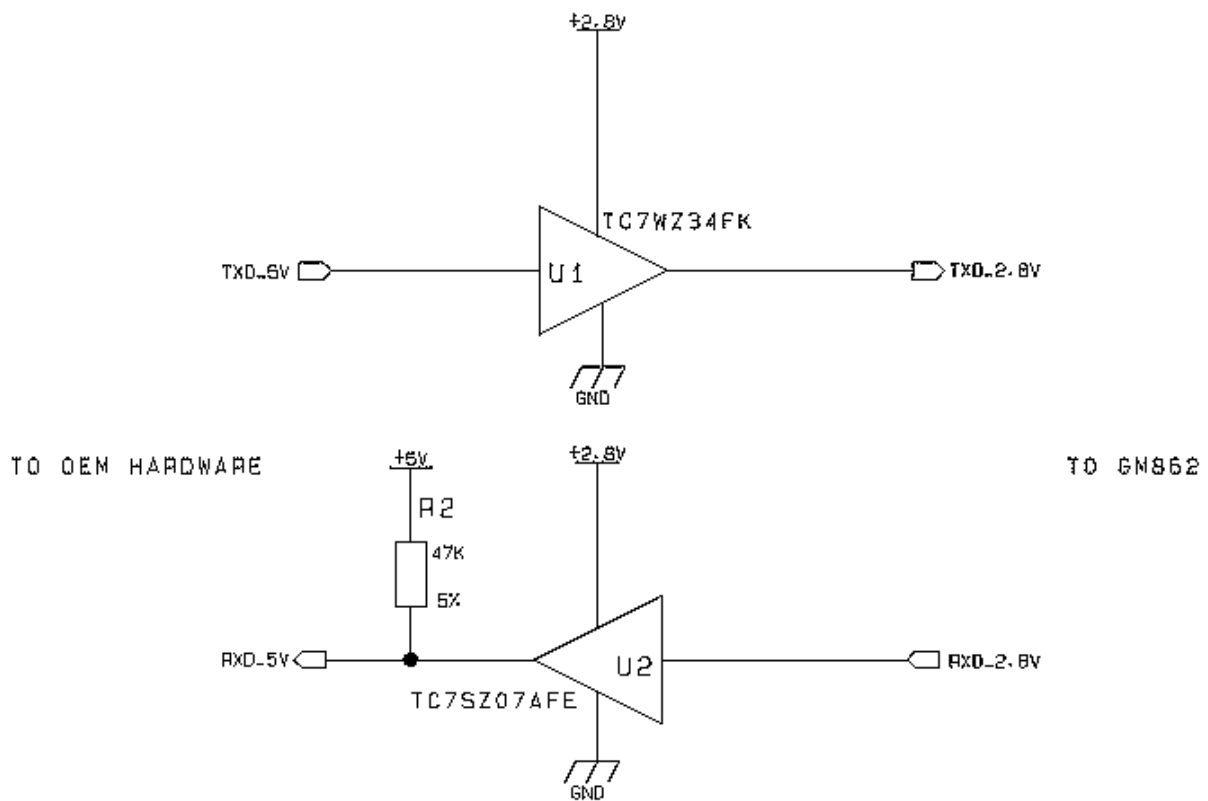

TIP: This logic IC for the level translator and 2.8V pull-ups (not the 5V one) can be powered directly from PWRMON line of the GM862-QUAD / PY. Note that the TC7SZ07AE has open drain output, therefore the resistor R2 is mandatory.



NOTE: The UART input line TXD (*rx_uart*) of the GM862-QUAD / PY is NOT internally pulled up with a resistor, so there may be the need to place an external 47K Ω pull-up resistor, either the DTR (*dtr_uart*) and RTS (*rts_uart*) input lines are not pulled up internally, so an external pull-up resistor of 47K Ω may be required.

A power source of the internal interface voltage corresponding to the 2.8VCMOS high level is available at the PWRMON pin on the connector, whose absolute maximum output current is 1mA.

A maximum of 9 resistors of 47 K Ω pull-up can be connected to the PWRMON pin, provided no other devices are connected to it and the pulled-up lines are GM862-QUAD / PY input lines connected to open collector outputs in order to avoid latch-up problems on the GM862-QUAD / PY.

Care must be taken to avoid latch-up on the GM862-QUAD / PY and the use of this output line to power electronic devices shall be avoided, especially for devices that generate spikes and noise such as switching level translators, micro controllers, failure in any of these condition can severely compromise the GM862-QUAD / PY functionality.

NOTE: The input lines working at 2.8VCMOS can be pulled-up with 47K Ω resistors that can be connected directly to the PWRMON line provided they are connected as in this example. NO OTHER devices than those suggested should be powered with the PWRMON line; otherwise the module functionality may be compromised.

It is important to consider that the added circuit must have consumption lower than 1mA. In case of reprogramming of the module has to be considered the use of the RESET line to start correctly the activity.

The preferable configuration is having an external supply for the buffer.



6 Audio Section Overview

The Base Band Chip of the GM862-QUAD / PY Telit Module provides two different audio blocks; both in transmit (*Uplink*) and in receive (*Downlink*) direction:

“*MT lines*” should be used for handset function,
“*HF lines*” is suited for hands -free function (car kit).

These two blocks can be active only one at a time, selectable by *AXE* hardware line or by *AT* command.

The audio characteristics are equivalent in transmit blocks, but are different in the receive ones and this should be kept in mind when designing.



GM862-QUAD / PY Hardware User Guide
1v0300748 Rev. 1 - 24/10/06

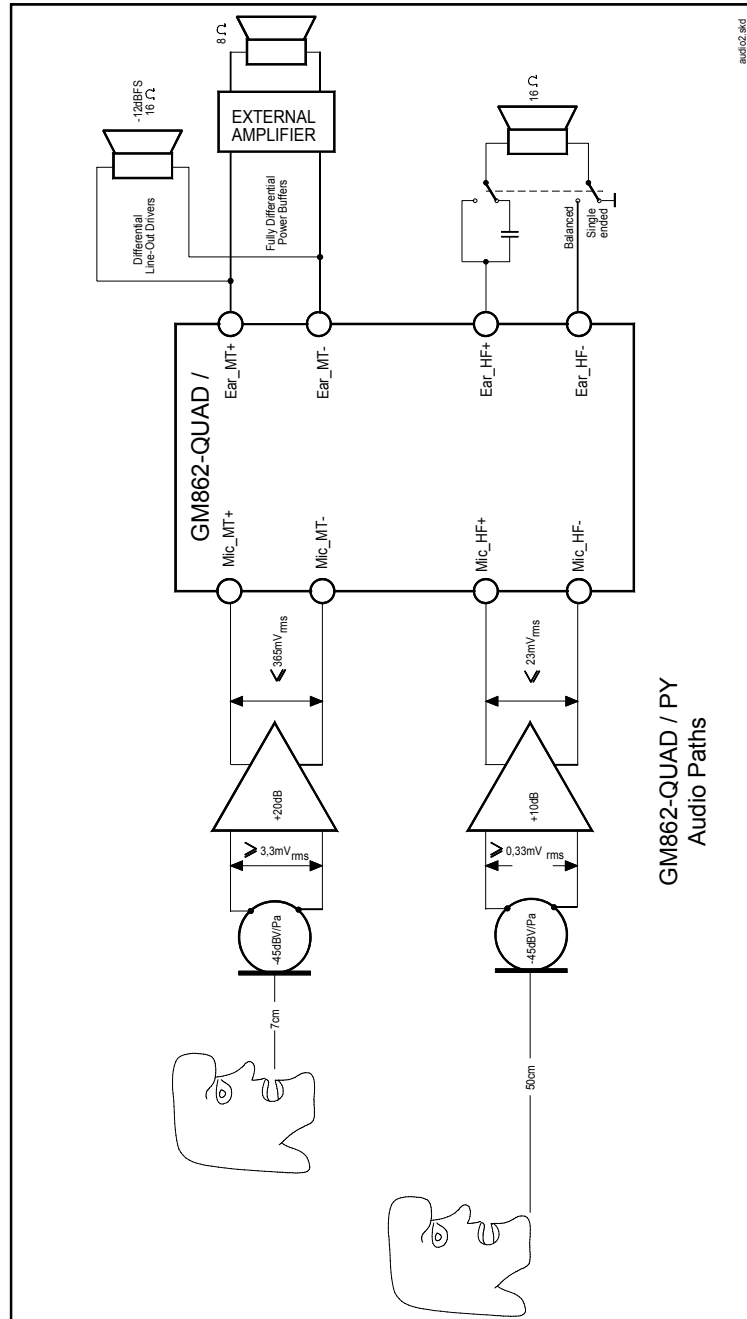

6.1 Microphone Paths Characteristic and Requirements



TIP: being the microphone circuitry the more noise sensitive, its design and layout must be done with particular care. Both microphone paths are balanced and the OEM circuitry should be balanced designed to reduce the common mode noise typically generated on the ground plane. However also an unbalanced circuitry can be used for particular OEM application needs.



TIP: due to the difference in the echo canceller type, the “Mic_MT” audio path is suited for Handset applications, while the “Mic_HF” audio path is suited for hands-free function (car kit). The Earphone applications should be made using the “Mic_HF” audio path but **DISABLING** the echo canceller by software AT command. If the echo canceller is left active with the Earphone, then some echo might be introduced by the echo cancel algorithm.

“Mic_MT” 1st differential microphone path

| | |
|---|---|
| <ul style="list-style-type: none"> • line coupling • line type • coupling capacitor • differential input resistance • differential input voltage • microphone nominal sensitivity • analog gain suggested • echo canceller type | <p>AC balanced ≥ 100nF 50kΩ ≤ 1,03V_{pp} (365mV_{rms}) -45 dBV_{rms}/Pa + 20dB handset</p> |
|---|---|

“Mic_HF” 2nd differential microphone path

| | |
|---|--|
| <ul style="list-style-type: none"> • line coupling • line type • coupling capacitor • differential input resistance • differential input voltage • microphone nominal sensitivity | <p>AC balanced ≥ 100nF 50kΩ ≤ 65mV_{pp} (23mV_{rms}) -45 dBV_{rms}/Pa</p> |
| <ul style="list-style-type: none"> • analog gain suggested • echo canceller type | <p>+10dB car kit hands-free</p> |





TIP: definition of the nominal sensitivity of the microphone lines .

The nominal sensitivity of the microphone lines indicates the voltage level on the GM862-QUAD / PY pins present during "normal spoken" conditions.
 For a handset , the "normal spoken" conditions take place when the talker mouth is 7cm far from the microphone ; under these conditions the voice will produce an acoustic pressure of $-4,7dBPa @1kHz$ on the microphone membrane .



TIP: electrical equivalent signal and operating voice levels .

At "normal spoken" conditions, a microphone having the suggested nominal sensitivity of $-45dB_{V_{rms}/Pa}$, will produce

the electrical equivalent signal :

$$MicLevel = (-45) + (-4.7) = -49.7 dB_{V_{rms}}$$

that means :

$$MicVoltage = 10^{(-49.7/20)} = 3.3 * 10^{-3} V_{rms}$$

During a call , this level varies according to the volume of the talker voice; usually the following rough thumb rule for the dynamic range may be used :

- 1) the talker is screaming . This is the *strongest voice level* condition: the signal increases by +20dB ;
- 2) the talker is whispering. This is the *lowest voice level* condition: the voice level decreases by – 50dB .

These changes must be considered for designing the external microphone amplifier.



TIP: example of external microphone amplifier calculation .

Let's suppose to use the *1st differential* microphone path .In this case the maximum differential input voltage to "Mic_MT" lines is $365mV_{rms}(1,03V_{pp})$ corresponding to $-8,76dBV$.

Now we can calculate the maximum voltage gain of an external microphone amplifier G_A :

$$[(MicLevel + 20dB) + G_A] = -8,76dBV$$

$$[-49,7 + 20 + G_A] = -8,76$$

$$-40,9 + 20 = -G_A$$

$$G_A = 20,94dB \longrightarrow \text{you can set } G_A = +20dB \text{ to use standard resistor values .}$$





TIP: environment consideration .

For *hands-free/car kit* microphone, you must take into account the voice attenuation, due to the distance between the microphone itself and the talker, when designing the external microphone amplifier.

Not only, you must consider that the microphone will pick up also ambient noise; to overcome this problem it is preferable to set the gain of the microphone *10dB* lower with respect to the calculated value for a nominal sensitivity. The corresponding reduction in signal level will be compensated by an increased voice volume of the talker which will speak louder because of the ambient noise.

For a car cabin usually the distance between the microphone itself and the talker is *40/50cm* ; in these conditions the attenuation can be considered as a thumb rule around *20dB* .

For the earphone we shall distinguish two different types: the earphones having the microphone sustained close to the mouth and the ones having the microphone on the earpiece cable.

The same considerations for the additional voice attenuation due to the distance from the microphone and the noise pick up can be made for the earphone having the microphone on the earpiece cable, while the other kind of earphone shall be threaten as an handset.



TIP: how to compensate the losses in car cabin hands-free condition.

The voice signal , that in the "normal spoken" conditions produces on the microphone membrane an acoustic pressure of -4,7dBPa at 1kHz , will have a further attenuation of 20dB due the 50cm distance .

Therefore a microphone having the suggested nominal sensitivity of -45dBV_{rms}/Pa, will produce a lower electrical

equivalent signal :

$$\text{MicLevel} = (-45) + (-4.7) - 20 = -69.7$$

that means :

$$\text{MicVoltage} = 10^{(-49.7 / 20)} = 0,33 * 10^{-3}$$

Setting the "microphone gain" at +10dB (3 times), the signal in the nominal conditions on the "Mic_HF" inputs s of GM862-QUAD / PY Telit Module will be :

$$\text{"Mic_HF" Level} = 0,33 * 10^{-3} * 3 = 1 * 10^{-3}$$

Hence in these conditions the signal level on the "**Mic_HF**" input pads of the GM862-QUAD / PY is 10 dB (3 times) lower than the nominal, as suggested.



6.2 General Design Rules

There are several configurations for the audio paths, but the most effective difference is between balanced and unbalanced microphone configuration.

It is highly recommended to keep the whole microphone path balanced even if this means having 2 wires connecting the microphone instead of one needed (plus ground) in the unbalanced case. The balanced circuitry is more suited because of its good common mode noise rejection, reducing the 216 Hz burst noise produced during the GSM transmissions.

- Where possible use balanced microphone circuitry
- Keep the microphone traces on the PCB and wires as short as possible.
- If your application requires an unbalanced microphone, then keep the lines on the PCB balanced and "unbalance" the path close to the microphone wire connector if possible.
- For the microphone biasing voltage use a dedicated voltage regulator and a capacitor multiply circuit.
- Make sure that the microphone traces in the PCB don't cross or run parallel to noisy traces (especially the power line)
- If possible put all around to the microphone lines a ground trace connected to the ground plane by several vias. This is done in order to simulate a shielded trace on the PCB.
- The biasing circuit and eventually the buffer can be designed in the same manner for the internal and external microphones.

6.3 Other Considerations

If your application is a hands-free/car kit scenario, but you need to put microphone and speaker inside the same box:

- Try to have the maximum possible distance between them, at least 7cm;
- because the microphone type is very important, if you use an omni-directional one (and this is the typical applicaton) please seal it on the rear side (no back cavity) in order not to collect unwanted signals ;
- try to make divergent the main axes of the two devices .



6.4 Microphone Biasing

The electret microphones usually need a biasing voltage to work properly. Refer to your microphone provider for the characteristics required.

NOTE: The microphones have a hot wire were the positive biasing must be connected. Usually it is indicated by a + symbol or a red point. If the polarity of the bias is reversed, then the microphone will not work properly. For this reason be sure to respect the mic. biasing polarity.

6.4.1 Balanced Microphone Biasing

The balanced microphone bias voltage should be obtained from a dedicated voltage regulator, in order to eliminate the noise present on the power lines. This regulator can be the same for all the audio paths. The microphone should be supplied from a capacitor multiply circuit. For example a circuit for the balanced microphone biasing can be:

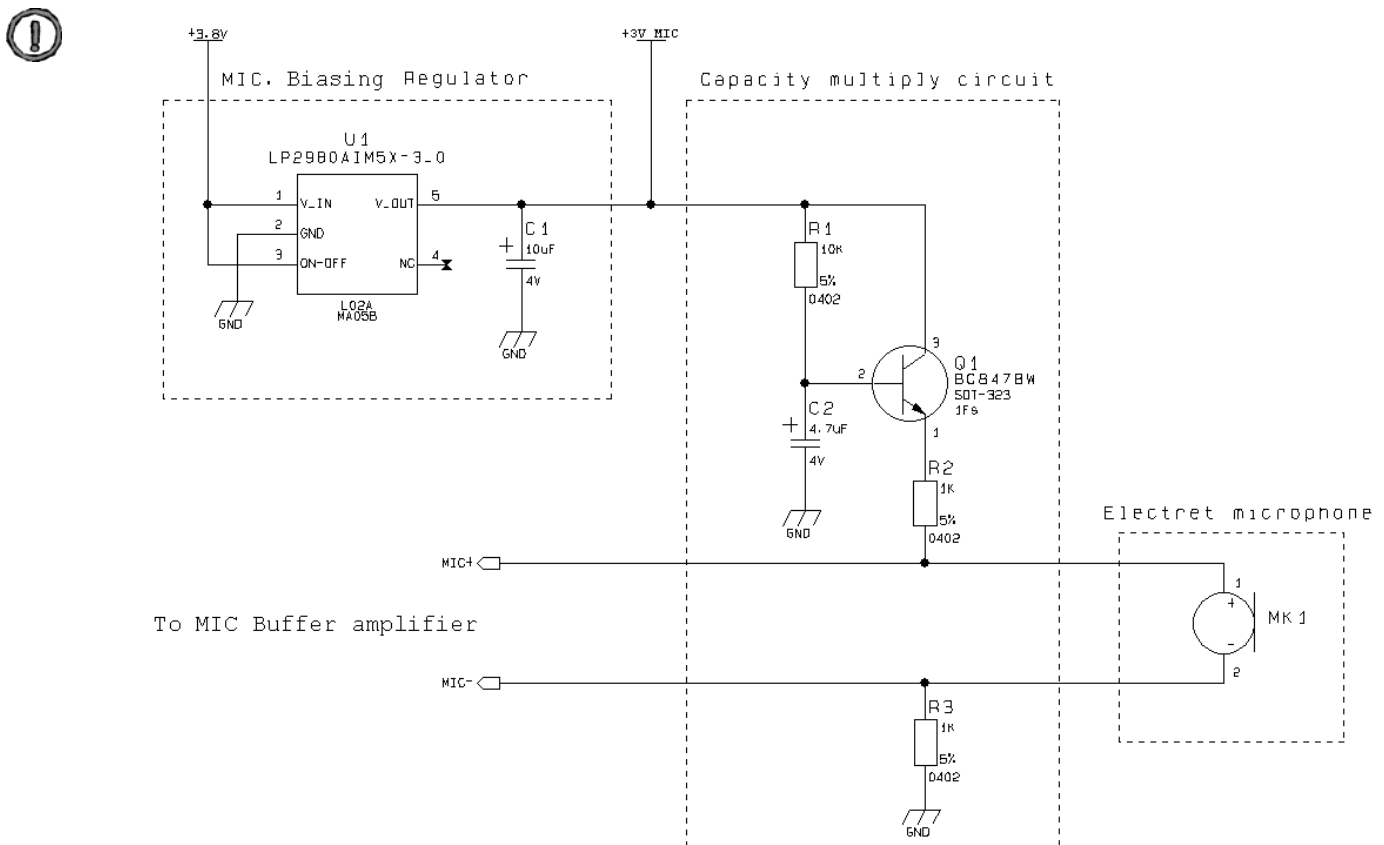

NOTE: In the balanced application the resistors R2 and R3 must have the same value to keep the circuit balanced.



NOTE: The cable to the microphone should not be shielded; instead a twisted pair cable shall be used.

NOTE: The microphone sensitivity changes with the value of R2 and R3. Usually the microphones are characterized with 2kΩ biasing resistance, so try to keep the sum of R2 and R3 around 2kΩ. Refer to your microphone manufacturer for the mic. characteristics.

6.4.2 Unbalanced Microphone Biasing

The unbalanced microphone biasing voltage should be obtained from a dedicated voltage regulator, in order to eliminate the noise present on the power lines. This regulator can be the same for all the audio paths. The microphone should be supplied from a capacitor multiply circuit.

For example a circuit for the unbalanced microphone biasing can be:

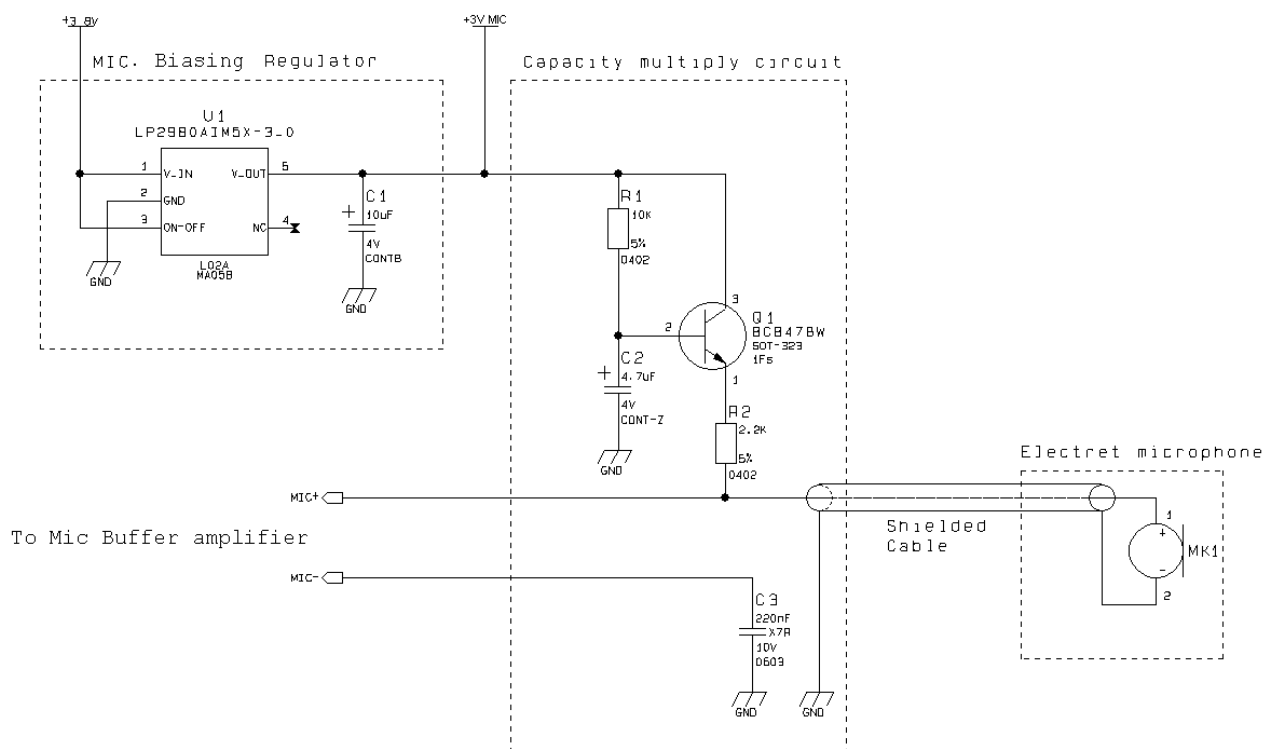

6.5 Microphone Buffering

As seen previously, a microphone shall be connected to the input pins of the GM862-QUAD / PY through a buffer amplifier that boosts the signal level to the required value.

Again the buffered microphone circuitry can be balanced or unbalanced: where possible it is always preferable a balanced solution. The buffering circuit shall be placed close to the microphone or close to the microphone wire connector.

6.5.1 Buffered Balanced Mic.

A sample circuit can be:

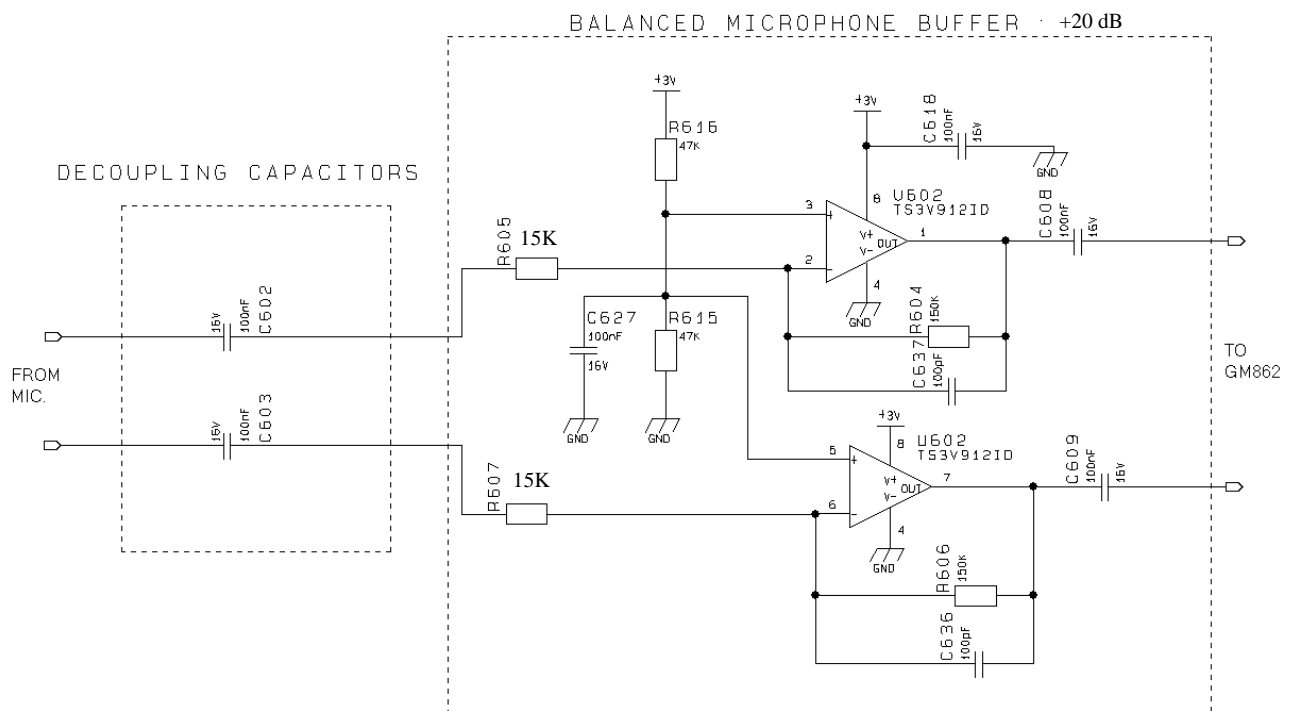

This circuit has a gain of 10 times (+20 dB), and is therefore suited for the “*Mic_MT*” input if you have a microphone with a sensitivity close to the suggested one ($-45 \text{ dBV}_{\text{rms}}/\text{Pa}$). If your microphone has a different sensitivity or if the buffer is connected to the “*Mic_HF*” inputs, then a gain adjustment shall be done by changing resistors R604 and R606 (if the required value is not a standard one, you can change R605 and R607) and as a consequence the capacitors C636 and C637 to maintain the bandwidth 150-4000Hz (at -3dB).



The buffer gain is given by the formula:

$$Gain = \frac{R604}{R605} = \frac{R606}{R607}$$

The C636 and C637 capacitors are placed in order to cut off the gain at higher frequencies than the transmitted GSM band, the cutoff frequency (-3dB) should be 3500Hz in order to have -1dB at 3kHz. The cutoff frequency is given by the formula:

$$freq. = \frac{1}{2\pi * R604 * C637} = \frac{1}{2\pi * R606 * C636} \text{ [Hz]}$$



TIP: example of calculation.

Let's assume you have a microphone with a sensitivity of -45 dBV_{rms}/Pa and you want to use it in 1st differential microphone path ("Mic_MT" inputs) in "normal spoken" conditions at acoustic pressure of -4.7dBPa.

As reported at page 33 , the electrical level output from the microphone will be :

$$MicLevel = (-45) + (-4.7) = -49.7 \text{ dB}_{V_{rms}}$$

corresponding to:

$$MicVoltage = 10^{(-49.7 / 20)} = 3.3 * 10^{-3} \text{ V}_{rms}$$

When the talker is screaming , we will have a signal of 330 mV_{rms} on the "Mic_MT" inputs due to a 20dB higher Mic Level (see TIP 1) with a buffer gain G_A :

$$G_A = 20 \log (AmplifierOutput / MicVoltage) = 20 \log (330 * 10^{-3}) / (3.3 * 10^{-3}) = 20 \log 10 = 20 \text{ dB}$$

The corresponding values for the resistors on the buffer could be (if we keep the input resistance 10kΩ)

$$R604 = R606 = gain * R607 = gain * R605 = 10 * 15 = 150 \text{ k}\Omega$$

The commercial values of 150kΩ & 15kΩ are then chosen.

As a consequence the values of the capacitors C636 and C637 shall be:

$$C636 = C637 = 1 / (2\pi * 4000 * R606) = 265 * 10^{-12} \text{ F}$$

A commercial value of 270pF gives a cutoff frequency of 3931Hz with an errorless than 1,8% .



6.5.2 Buffered Unbalanced (Single Ended) Microphone .

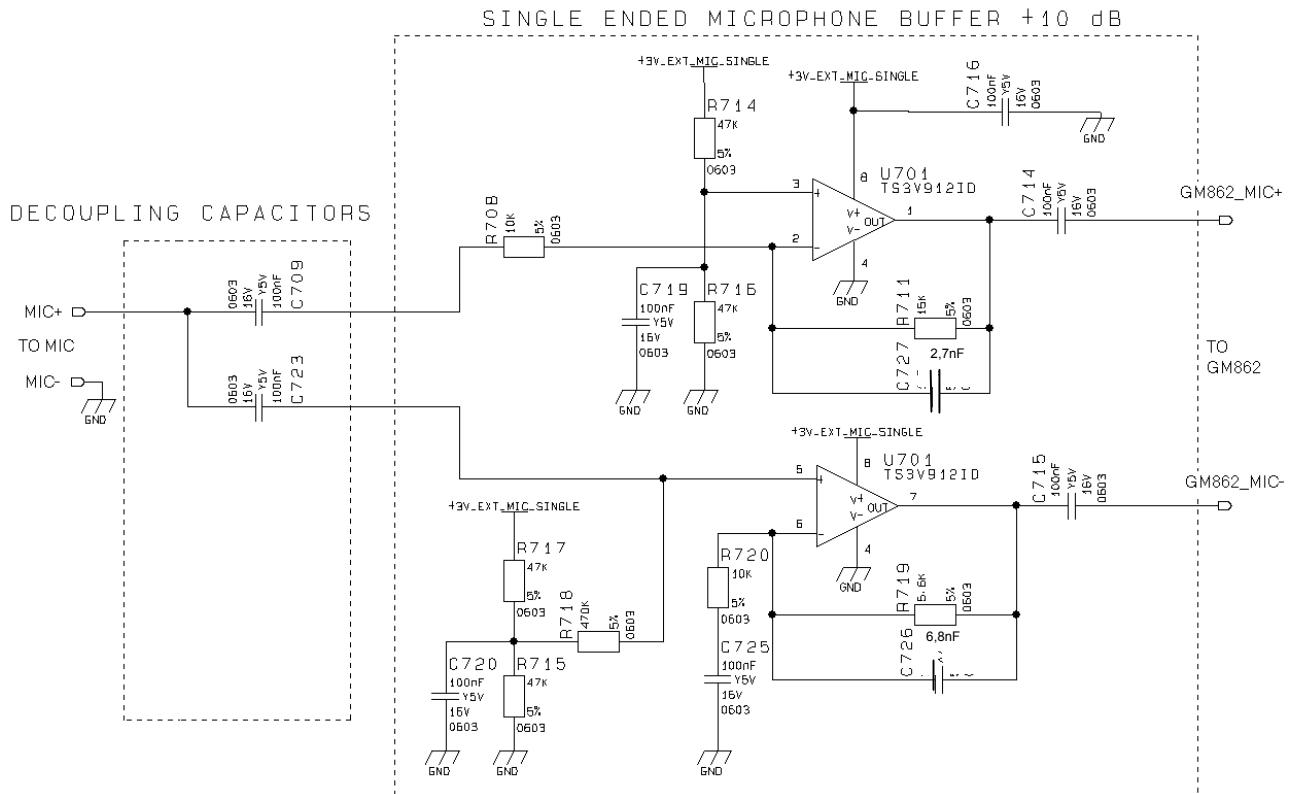

The above schematic can be used for a single ended (*buffered unbalanced*) microphone ; the required biasing circuitry is not included. Note also that the capacitor C3 is not needed .
The gains of the two amplifiers are given by the formulas :

$$Gain(\text{not inverting buffer}) = 1 + \frac{R719}{R720} \qquad Gain(\text{inverting buffer}) = \frac{R711}{R708}$$

Assigning half of overall gain to each amplifier, you will obtain the requested gain because of doubling the microphone signal path; in fact by the use of two amplifiers (the upper as “inverting” and the lower as “not inverting” configuration) we obtain an additional +6dB gain (2 times) .

Remember : the “not inverting “ amplifier section gain shall not be less than 1 .

Like for the balanced buffered microphone , the amplifier overall gain can be modify changing the value of resistor R719/R720 and R711 and as a consequence the capacitors C726 and C727. It is advisable to change R708 only if you have difficulty to find a commercial value for R711 ; in this case change R708 as little as possible .

The -3dB bandwidth is given by the approximated formula (considering C725 >> C726):

$$freq. = \frac{1}{2\pi * R719 * C726} = \frac{1}{2\pi * R711 * C727} \text{ [Hz]}$$



The buffer bandwidth at -3dB shall be 4KHz.

Note that the biasing of the operational amplifier is given for the inverting amplifier by the series divider R714-R715. The 100nF capacitor C719 is needed to filter the noise that could be coupled to that divider. For the not inverting operational amplifier the biasing is given by a different divider R715-R717 with the capacitor C720 and through a series resistor R718 of 470KΩ.



TIP: example of calculation.

Let's assume you have a microphone with a sensitivity of $-45\text{dBV}_{\text{rms}}/\text{Pa}$ and you want to use it in 2nd differential microphone path ("Mic_HF" inputs) in "normal spoken" conditions at acoustic pressure of -4.7dBPa .

As reported at page XX , the electrical level output from the microphone will be :

$$\text{MicLevel} = (-45) + (-4.7) = -49.7 \text{ dBV}_{\text{rms}}$$

but we have to consider 20dB loss due to the higher distance from the mouth of the talker (50cm) .

$$\text{MicLevel} = (-49.7) + (-20) = -69.7 \text{ dBV}_{\text{rms}}$$

corresponding to

$$\text{MicVoltage} = 10^{(-69.7/20)} = 0,33 * 10^{-3}$$

In order to have a signal of $1 \text{ mV}_{\text{rms}}$ at the "Mic_HF" inputs , as suggested at TIP "environment consideration " ,

the buffer must have a gain

$$\hat{G}_A = \text{Mic_HF} / \text{MicVoltage} = (1 * 10^{-3}) / (0,33 * 10^{-3})$$

or +10 dB

Keeping in mind that " balancing the line will double the signal", to calculate the resistor values assign half of required gain G_A to each amplifier section . And therefore $G_S = 1,5$ times (or +3,52dB) .

Choosing as $10\text{k}\Omega$ as the input resistance , the corresponding values for the resistors on the buffer will be :

$$R711 = G_S * R708 = 1.5 * 10 = 15 \text{ k}\Omega$$

$$R719 = (G_S - 1) * R720 = (1.5 - 1) * 10 = 5 \text{ k}\Omega$$

The commercial values of **15kΩ** and **5.6kΩ** be accepted .

As a consequence of the assigned values of the resistors, the nominal values of C726 and C727 are :



GM862-QUAD / PY Hardware User Guide

1vv0300748 Rev. 1 - 24/10/06

$$C726 = 1 / (2\pi * 4000 * R719) = 7.10 * 10^{-9} F$$

$$C727 = 1 / (2\pi * 4000 * R711) = 2.65 * 10^{-9} F$$

*modified in **6,8nF** ($f_{c1}=4181\text{Hz}$) and **2,7nF** ($f_{c2}=3931\text{Hz}$) because of commercial values .*



7 OUTPUT LINES (Speaker)

7.1 Short Description.

The Telit GM862-QUAD / PY provides two audio paths in receive section. Only one of the two paths can be active at a time, selectable by AXE hardware line or by AT command.

You must keep in mind the different audio characteristics of the receive blocks when designing:

→ the “**Ear_MT**” lines *EPN1* and *EPP1* are the *Differential Line-Out Drivers* ; they can drive an external amplifier or directly a **16 Ω earpiece** at -12dBFS (*) ;

→ the “**Ear_HF**” lines *EPPA1_2* and *EPPA2* are the *Fully Differential Power Buffers* ; they can directly drive a **16Ω speaker** in differential (*balanced*) or single ended (*unbalanced*) operation mode .

(*) *FS* : acronym of *Full Scale*. It is equal to 0dB, the maximum Hardware Analog Receive Gain of BaseBand Chip.

The “**Ear_MT**” audio path should be used for handset function, while the “**Ear_HF**” audio path is suited for hands-free function (car kit).

Both receiver outputs are B.T.L. type (Bridged Tie Load) and the OEM circuitry shall be designed bridged to reduce the common mode noise typically generated on the ground plane and to get the maximum power output from the device; however also a single ended circuitry can be designed for particular OEM application needs.



7.2 Output Lines Characteristics

“Ear_MT” Differential Line-out Drivers Path

| | |
|------------------------------------|---|
| • line coupling: | DC |
| • line type: | bridged |
| • output load resistance : | $\geq 14 \Omega$ |
| • internal output resistance: | 4 Ω (typical) |
| • signal bandwidth: | 150 - 4000 Hz @ -3 dB |
| • max. differential output voltage | 1310 mV _{rms} (typ, open circuit) |
| • differential output voltage | 328mV _{rms} /16 Ω @ -12dBFS |
| • SW volume level step | - 2 dB |
| • number of SW volume steps | 10 |

“Ear_HF” Power Buffers path

| | |
|------------------------------------|--|
| • line coupling: | DC |
| • line type: | bridged |
| • output load resistance : | $\geq 14 \Omega$ |
| • internal output resistance: | 4 Ω (>1,7 Ω) |
| • signal bandwidth: | 150 - 4000 Hz @ -3 dB |
| • max. differential output voltage | 1310 mV _{rms} (typ, open circuit) |
| • max. single ended output voltage | 656 mV _{rms} (typ, open circuit) |
| • SW volume level step | - 2 dB |
| • number of SW volume steps | 10 |



7.3 General Design Rules

There are several configurations for the audio output path, but the various design requirements can be grouped into three different categories:

- handset earphone (low power, typically a handset)
- hands-free earphone (low power, typically a earphone)
- car kit speakerphone (high power, typically a speaker)

The three groups have different power requirements, usually the first two applications need only few mW of power, which can be directly drained from the GM862-QUAD / PY pads, provided a suited speaker is used. This direct connect design is the cheaper and simpler solution and will be suited for the most of the earphone design requirements. There's no need to decouple the output ear lines if a suited earpiece is connected. For the last group, the speakerphone, a power amplifier is required to raise the output power up to 5-10W required in a car cabin application.

All the designs shall comply with the following guidelines:

- Where possible use a bridged earphone circuitry, to achieve the maximum power output from the device.
- Keep the earphone traces on the PCB and wires as short as possible.
- If your application requires a single ended earpiece and you want a direct connection, then leave one of the two output lines open and use only the other referred to ground. Remember that in this case the power output is 4 times lower than the bridged circuit and may not be enough to ensure a good voice volume.
- Make sure that the earphone traces in the PCB don't cross or run parallel to noisy traces (especially the power line)
- The cable to the speaker shall be a twisted pair with both the lines floating for the bridged output type, shielded with the shield to ground for the single ended output type.

7.3.1 Noise Filtering

The I/O of the PCB should have a noise filter close to the connector, to filter the high frequency GSM noise. The filter can be a Π formed by 2 capacitor and a inductance, with the one capacitor of $39pF - 0603$ case , and the other capacitor of $1nF - 0603$; the inductance shall have a value of $39\mu H$.



7.4 Handset Earphone Design

As seen previously, a 16Ω earpiece can be directly connected to the output pads EAR_MT+ and EAR_MT- of the GM862-QUAD / PY.

This solution is often the more cost effective, reducing the components count to a minimum. There are several limitations to the use of this solution: speaker direct connect imposes the speaker characteristics to be almost exactly the suggested ones, otherwise the power output may be reduced (if speaker impedance is bigger than 16Ω) or the GM862-QUAD / PY ear port may be damaged (if speaker impedance is less than 15Ω).

The other limitation of the speaker direct connection is the power output capability of the GM862-QUAD / PY which is limited and for some particular applications may not be enough.

For these reasons, when the power output of the GM862-QUAD / PY is not enough or if the speaker characteristics are different from the suggested, then it is preferable to use an amplifier to increase the power and current output capabilities.

Again the output from the GM862-QUAD / PY is bridged and both lines should be used, where possible, as inputs to the power amplifier. This ensures a higher common mode rejection ratio, reducing the GSM current busts noise on the speaker output.

In this case the "EAR_MT" lines from the GM862-QUAD / PY should be AC coupled with a ceramic capacitor of 100nF (or bigger).

It is always desirable to have a mute control on the amplifier, in order to turn it off while the device is not sending signal to the output, in this manner the amplifier background noise which may be audible during idle conditions is cut off.

A principle schematic may be:

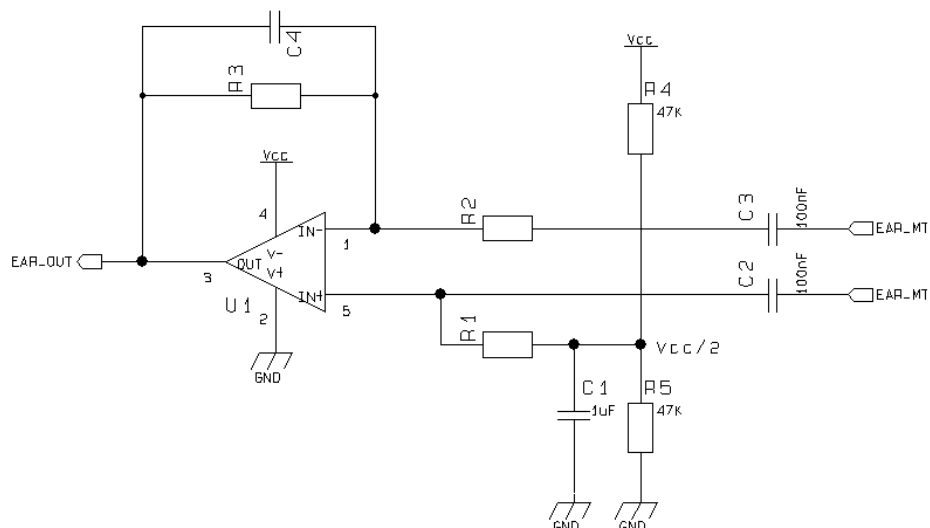

The resulting gain and high pass cut can be obtained with the formula:

$$Gain = \frac{R3}{R2}$$

$$freq. = \frac{1}{2\pi * R3 * C4} \text{ [Hz]}$$

And an example of internal Ear amplifier could be :

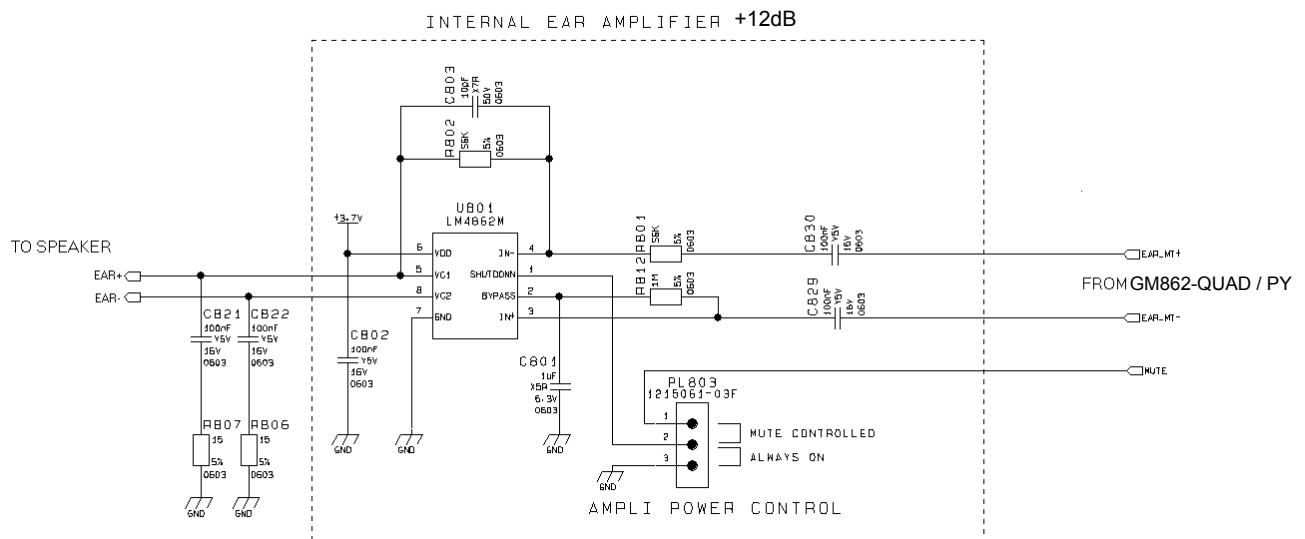

Some amplifier require a low impedance load at high frequency in order to avoid auto oscillation, this can be made with a capacitor (100nF) in series with a resistor (15Ω).

When designing your application, remember to provide an adequate bypass capacitor to the amplifier and place it close to the power input pin of the IC, keeping the traces as short as possible.

7.5 Hands-Free Earphone (Low Power) Design

The same design considerations made for the handset are valid for the hands-free earphone.



7.6 Car Kit Speakerphone Design

For the car kit speaker phone function the power output requirement is usually at least 4W, therefore an amplifier is needed to boost the GM862-QUAD / PY output.

The design of the amplifier shall comply with the following guidelines:

- The input to the amplifier **MUST** be taken from the “Ear_HF” audio path of the GM862-QUAD / PY, because of its echo canceller parameters suited to a car cabin use.
- The amplifier shall have a gain of 30-40 times (29-32 dB) to provide the desired output power of 5-10W with the signal from the GM862-QUAD / PY “Ear_HF” audio output lines.
- If the amplifier has a fixed gain then it can be adjusted to the desired value by reducing the input signal with a resistor divider network.
- The amplifier shall have a mute control to be used while not in conversation. This results in two benefits: eliminating the background noise when not in conversation and saving power.
- The power to the amplifier should be decoupled as much as possible from the GM862-QUAD / PY power supply, by either keeping separate wires and placing bypass capacitors of adequate value close to the amplifier power input pads.
- The biasing voltage of the amplifier shall be stabilized with a low ESR (e.g. a tantalum) capacitor of adequate value.

NOTE: The GM862-QUAD / PY audio path connected to the car kit hands-free amplifier **MUST** be “Ear_HF” one, otherwise the echo cancellation will not be done due to the difference in the echo canceller characteristics of the GM862-QUAD / PY internal audio path from the external audio path.

Example of car kit amplifier schematic.

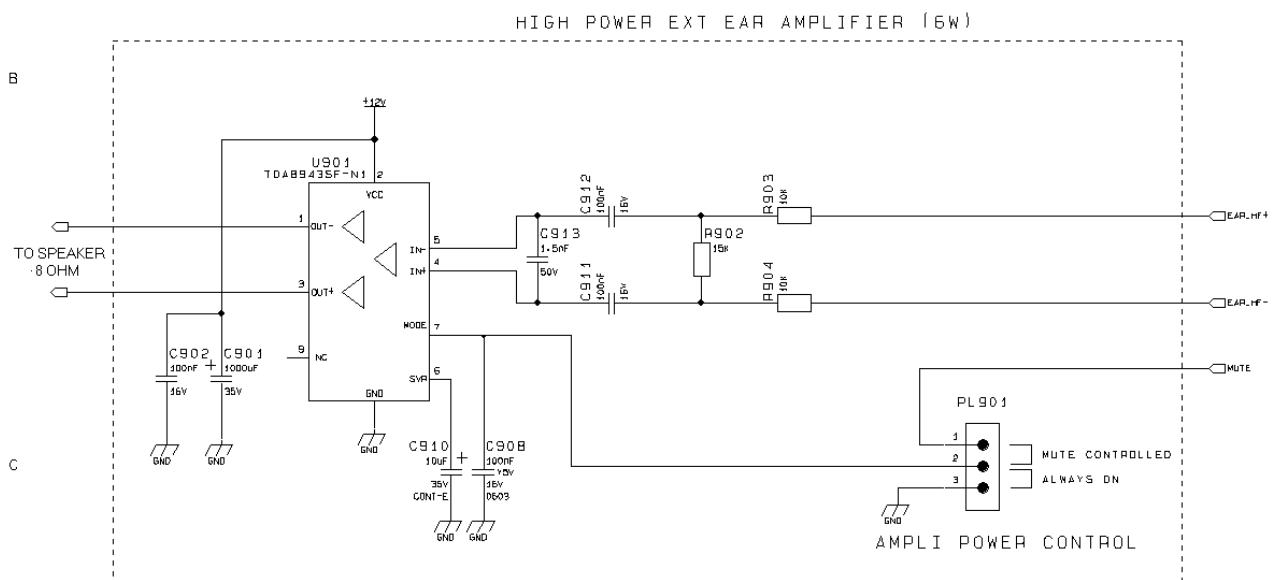

8 General Purpose I/O

The general purpose I/O pins can be configured to act in three different ways:

- input
- output
- alternate function (internally controlled)

Input pins can only be read and report the digital value (high or low) present on the pin at the read time; output pins can only be written or queried and set the value of the pin output; an alternate function pin is internally controlled by the GM862-QUAD / PY firmware and acts depending on the function implemented.

Not all GPIO pins support all these three modes:

- GPIO1 is an INPUT ONLY
- GPIO2 is an OUTPUT ONLY (open collector)
- GPIO3, GPIO4, GPIO8 to GPIO13 support both input or output mode but not Alternate function.
- GPIO5 supports all three modes and can be input, output, RFTXMON output (Alternate function)
- GPIO6 supports all three modes and can be input, output, ALARM output (Alternate function)
- GPIO7 supports all three modes and can be input, output, BUZZER output (Alternate function)

All GPIO pins except from GPIO1 and GPIO2 that are buffered with a transistor, are 2.8V CMOS signals and their interface levels are the same specified in the paragraph 5 Serial Port.

8.1 Logic level specifications

Where not specifically stated, all the interface circuits work at 2.8V CMOS logic levels. The following table shows the logic level specifications used in the [GM862](#) interface circuits:

Absolute Maximum Ratings -Not Functional

| Parameter | Min | Max |
|--|-------|--------|
| Input level on any digital pin when on | -0.3V | +3.75V |
| Input voltage on analog pins when on | -0.3V | +3.0 V |



Operating Range - Interface levels (2.8V CMOS)

| Level | Min | Max |
|-------------------|------|-------|
| Input high level | 2.1V | 3.3V |
| Input low level | 0V | 0.5V |
| Output high level | 2.2V | 3.0V |
| Output low level | 0V | 0.35V |

For 2,0V signals:

Operating Range - Interface levels (2.0V CMOS)

| Level | Min | Max |
|-------------------|-------|-------|
| Input high level | 1.6V | 3.3V |
| Input low level | 0V | 0.4V |
| Output high level | 1,65V | 2.2V |
| Output low level | 0V | 0.35V |

Current characteristics

| Level | Typical |
|----------------|---------|
| Output Current | 1mA |
| Input Current | 1uA |



8.2 Using a GPIO pin as INPUT

The GPIO pins, when used as inputs, can be connected to a digital output of another device and report its status, provided this device has interface levels compatible with the 2.8V CMOS levels of the GPIO.

If the digital output of the device to be connected with the GPIO input pin has interface levels different from the 2.8V CMOS, then it can be connected to GPIO1 or can be buffered with an open collector transistor, provided a 47K Ω pull-up resistor is connected as seen in the paragraph 5.2 5V UART level translation.

8.3 Using a GPIO pin as OUTPUT

The GPIO pins, when used as outputs, can drive 2.8V CMOS digital devices or compatible hardware. When set as outputs, the pins (except from GPIO2 which is Open Collector) have a push-pull output and therefore the pull-up resistor may be omitted.

The GPIO2 pin, since it is an Open Collector output needs an external pull-up resistor.

8.4 Using the RFTXMON Output GPIO5

The GPIO5 pin, when configured as RFTXMON Output, is controlled by the GM862-QUAD / PY module and will rise when the transmitter is active and fall after the transmitter activity is completed.

For example, if a call is started, the line will be HIGH during all the conversation and it will be again LOW after hanged up.

8.5 Using the Alarm Output GPIO6

The GPIO6 pin, when configured as Alarm Output, is controlled by the GM862-QUAD / PY module and will rise when the alarm starts and fall after the issue of a dedicated AT command.

This output can be used to power up the GM862-QUAD / PY controlling microcontroller or application at the alarm time, giving you the possibility to program a timely system wake-up to achieve some periodic actions and completely turn off either the application and the GM862-QUAD / PY during sleep periods, dramatically reducing the sleep consumption to few μ A.

In battery powered devices this feature will greatly improve the autonomy of the device.



8.6 Using the Buzzer Output GPIO7

The GPIO7 pin, when configured as Buzzer Output, is controlled by the GM862-QUAD / PY module and will drive with appropriate square waves a Buzzer driver.

This permits to your application to easily implement Buzzer feature with ringing tones played at the call incoming, on SMS incoming or simply playing a tone when needed by your application.

A sample interface scheme is included below to give you an idea of how to interface a Buzzer to the GPIO7:

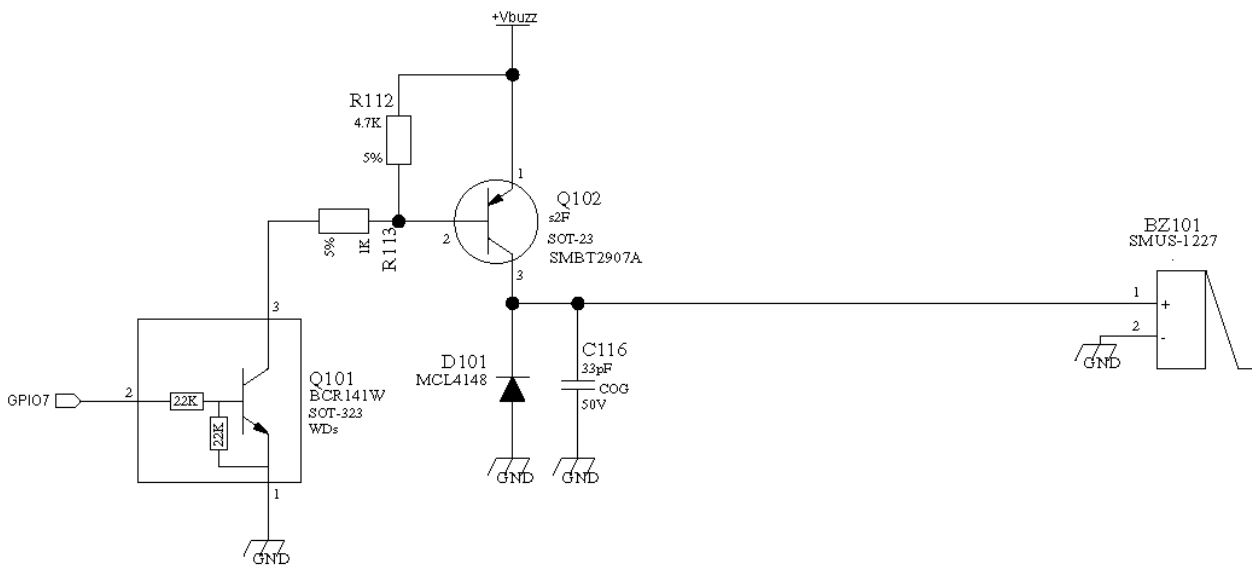

NOTE: To correctly drive a buzzer a driver must be provided, its characteristics depend on the Buzzer and for them refer to your buzzer vendor.



9 ADC section

9.1 ADC converter

9.1.1 Description

The GM862-QUAD / PY module provides a Analog to Digital Converter. The input line (named ADC_IN1) is available on Pin #6 of the B2B connector of the module and on pin 19 of PL104 on EVK2 Board.

The on board A/D is 11-bit converter. It is able to read a voltage level in the range of 0÷2 volts applied on the ADC pin input, store and convert it into 11 bit word.

| | Min | Max | Units |
|---------------------|-----|-----|-------|
| Input Voltage range | 0 | 2 | Volt |
| AD conversion | - | 11 | bits |
| Resolution | - | < 1 | mV |

9.1.2 Using ADC Converter

An AT command is available to use the ADC function.

The command is **AT#ADC=1,2**

The read value is expressed in mV

Refer to SW user guide or to GM862-QUAD / PY AT commands specification for the full description of this function.



10 Camera

10.1 Camera Transchip

The GM862-QUAD / PY provides a direct support for Transchip digital cameras with the following characteristics:

| | |
|--------------------------|-------------------------------------|
| Type: | TRANSCHIP TC5747 |
| Technology: | CMOS COLOR camera |
| Max picture size: | VGA 480x640 pixels landscape |
| Output format: | JPEG |
| Sensitivity: | 4 Lux |

10.1.1 Camera Interface Connectors

The 50-pins Molex connector of the module and a 24 pins ZIF connector for the CMOS camera provide the interface connection between GM862 and Transchip camera.

| Molex 52991-0508 GM862 | | | | TC5747MF24L | | |
|------------------------|---------------------|-----|---|-------------|---------|-----|
| Pin | Signal | I/O | Notes | Pin | Signal | I/O |
| 46 | GPIO3 PD(6) | O | I2C bus serial clock | 1 | SCLK | I |
| 2-4-6 | GND | | Ground | 2 | AGND | I |
| 50 | GPIO7 CAM_PWR_ON | O | External 2.8V Regulator enable controlled by CAM_PWR_ON pin | 3 | AVDD28 | I |
| 34 | GPIO9 PD(1) | O | Camera Reset | 4 | RESET_N | I |
| 25 | MON1 MON1_CAM | O | Clock | 5 | CLK_IN | I |
| 2-4-6 | GND | | Ground | 6 | DGND | I |
| | n.c | | | 7 | DOUT_0 | I/O |
| | n.c | | | 8 | DOUT_1 | I/O |
| | n.c | | | 9 | DOUT_2 | I/O |
| | n.c | | | 10 | DOUT_3 | I/O |
| | n.c | | | 11 | DOUT_4 | I/O |
| | n.c | | | 12 | DOUT_5 | I/O |
| | n.c | | | 13 | DOUT_6 | I/O |



GM862-QUAD / PY Hardware User Guide

1vv0300748 Rev. 1 - 24/10/06

| | | | | | | |
|-------|---------------------|-----|--|----|----------|-----|
| | n.c | | | 14 | DOUT_7 | I/O |
| | n.c | | | 15 | DOUT_8 | I/O |
| | n.c | | | 16 | VCLKOUT | O |
| | n.c | | | 17 | VALIDH | O |
| | n.c | | | 18 | VALIDV | O |
| 50 | GPIO7 CAM_PWR_ON | O | External 2.8V Regulator enable controlled by CAM_PWR_ON pin | 19 | DVDD28 | I |
| 47 | GPIO4 IICSDA_CAM | I/O | I2C bus serial data | 20 | SDIN | I/O |
| 2-4-6 | GND | | Ground | 21 | PS1 | I |
| 32 | GPIO8 PD(0) | O | Camera power type selector | 22 | PS2 | I |
| 2-4-6 | GND | | Ground | 23 | SHIELD | - |
| | | | Flash Enable | 24 | LED_CTRL | O |

* Filter the AVDD28.

** Use a Buffer between module clk out, MON1_CAM and camera clk in, CLK_IN.

*** Non-connected.

10.1.2 EVB for Camera Support

In order to interface the Telit GM862-QUAD / PY with a CMOS camera, Telit has developed an evaluation board. The EVB is provided by:

- 10 pin Berg male connector (PL201) and RS232 level translator that allows a direct connection to the PC. To switch on the level translator a jumper shall be set on PL203.
- 12 pin Berg male connector (PL202) to supply the GM862-QUAD / PY mounted on the EVB. The input source power should be in the range 4,5V-12V. Charge line is also provided in case a Li-Ion battery is connected to the VBATT pins. Charge input must fulfil charger line requests.
- 50 pin Molex male connector (PL103) to interface with the GM862-QUAD / PY directly.
- 30 pin Berg male connector (PL101) to interface with a PCB developed by the user or the EVK board. On this connector is available the complete audio path, the serial port lines with full handshaking, and the pins ON, AXE, RESET, GPIO1 and STAT_LED. Also the CHARGER_IN pin can be available placing a 0 ohm resistor.
- 18 pin ZIF female connector (SO101) for CMOS camera.
- ON/OFF button (SW102) to power on and off the module.
- GPIO1 button (SW101) for future applications.
- Led (DL101) for device status indication.

NOTE: The Philips 74LVC1G08GW must be placed close to the GM862 connector; the length of the line between CAMERA connector and MOLEX 50 PIN of GM862 must be max 5cm anyway.

NOTE: The CMOS cameras must be removed when the GPIO pins are used for I/O purpose.



GM862-QUAD / PY Hardware User Guide

1v0300748 Rev. 1 - 24/10/06

Pic 1. Camera Physical Detail & Connector

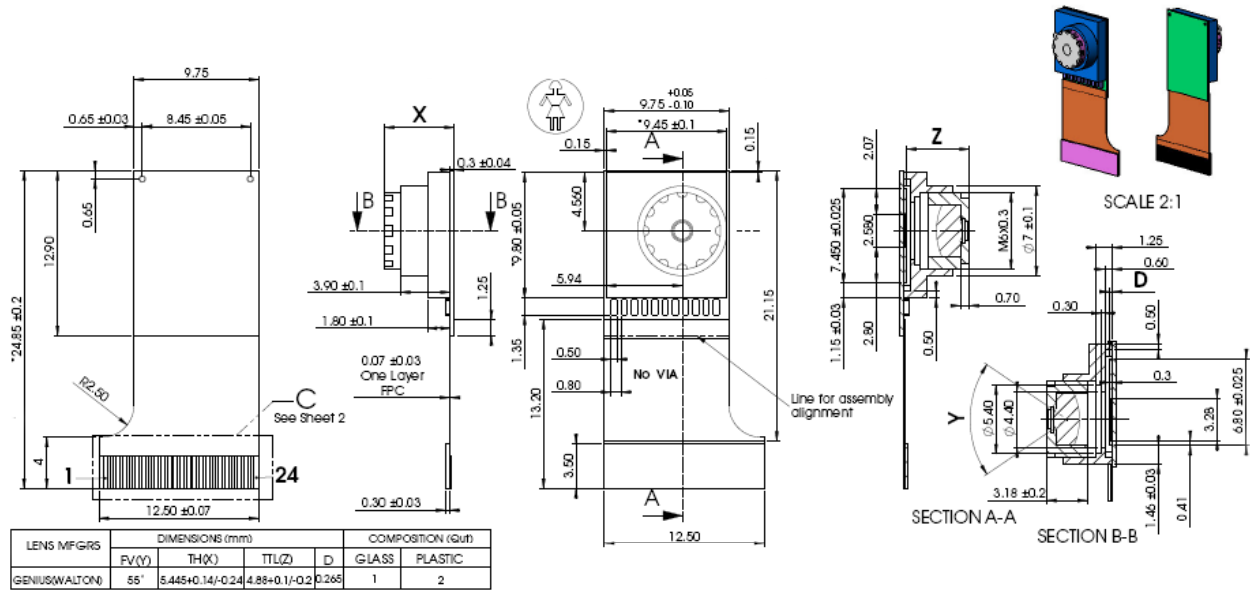

Pic 2. Camera Socket Connector

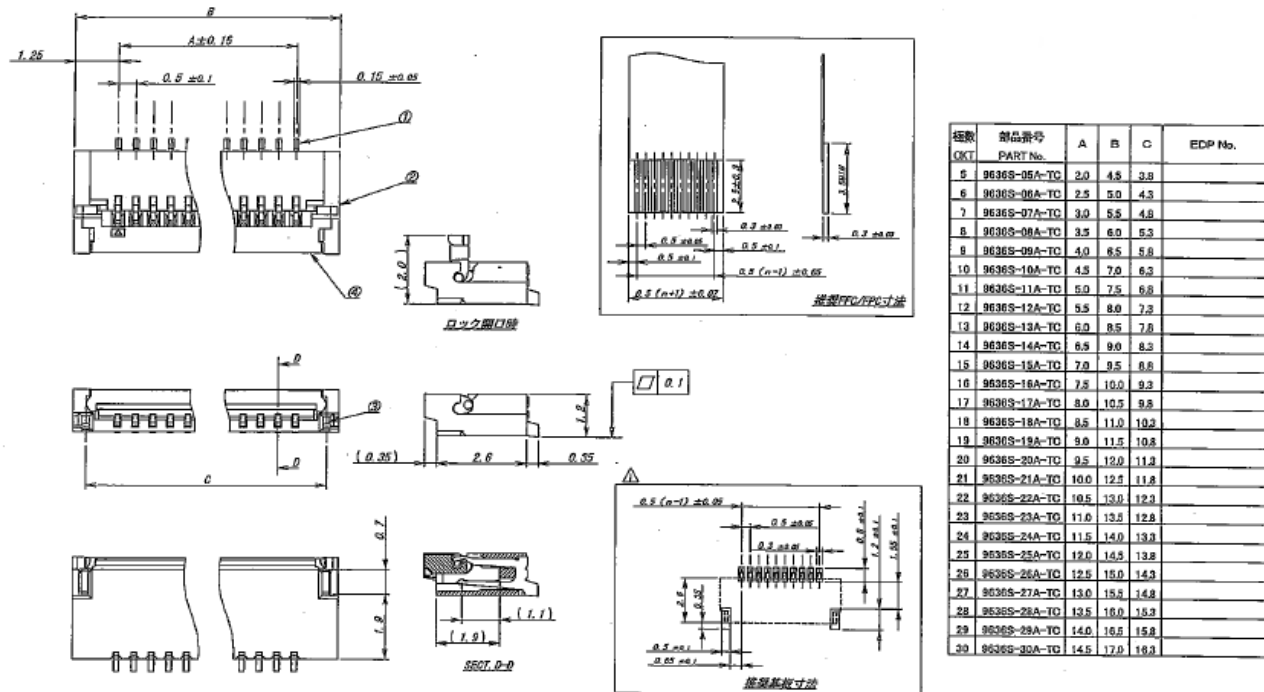

10.1.3 EVB for Transchip camera support

In order to interface the Telit GM862 with a CMOS camera, Telit has developed an evaluation board. The EVK allow connecting all Telit modules through 2 connectors of 40 pins each.

The I2CBUS DUAL CAMERA board is plugged in the 2 connectors of 30 pins each on the module board.

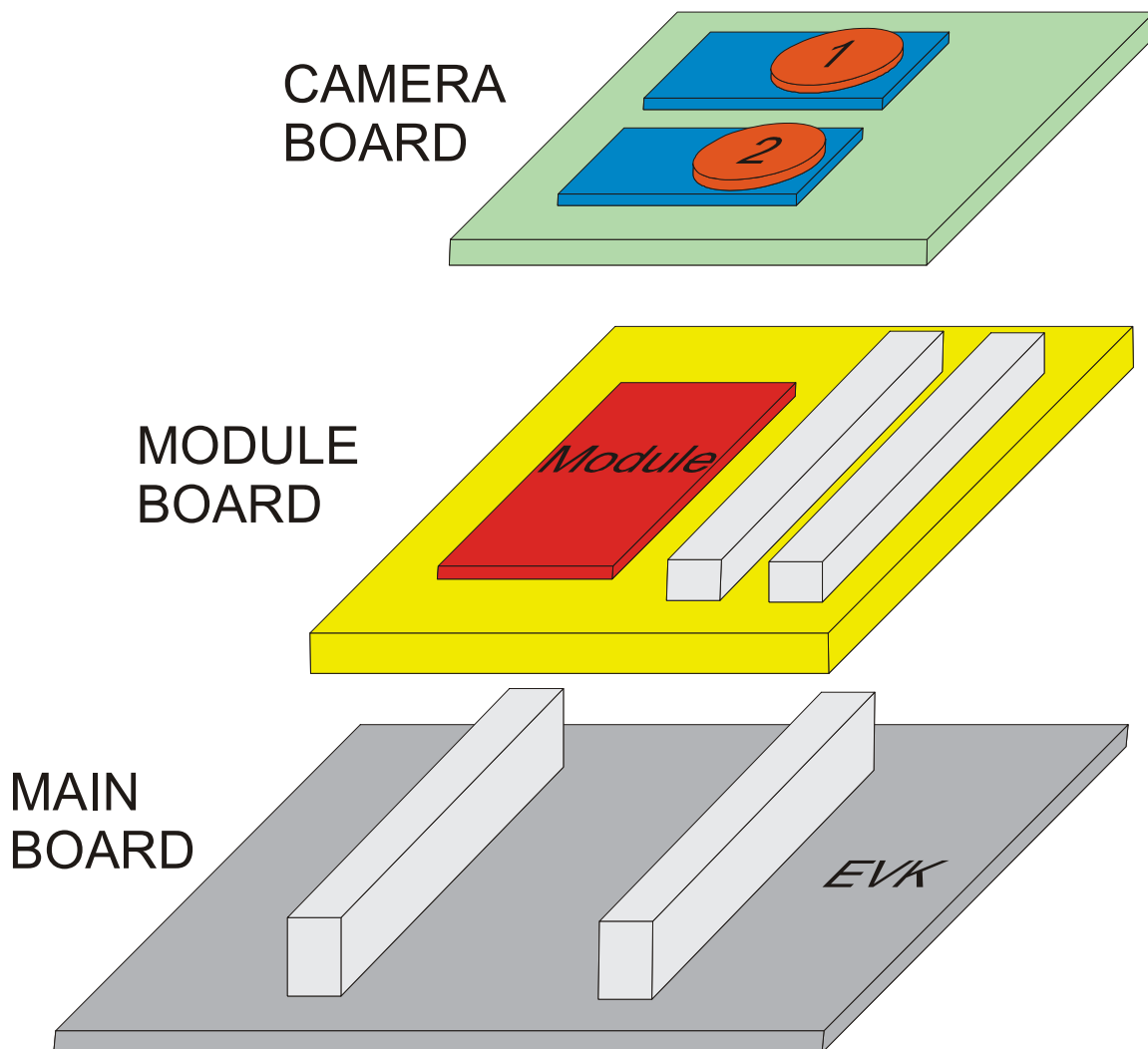

10.1.4 Block Diagram for supported camera

DVDD is an external power supply of 2.8V, controlled or gated by pin CAM_PWR_ON.

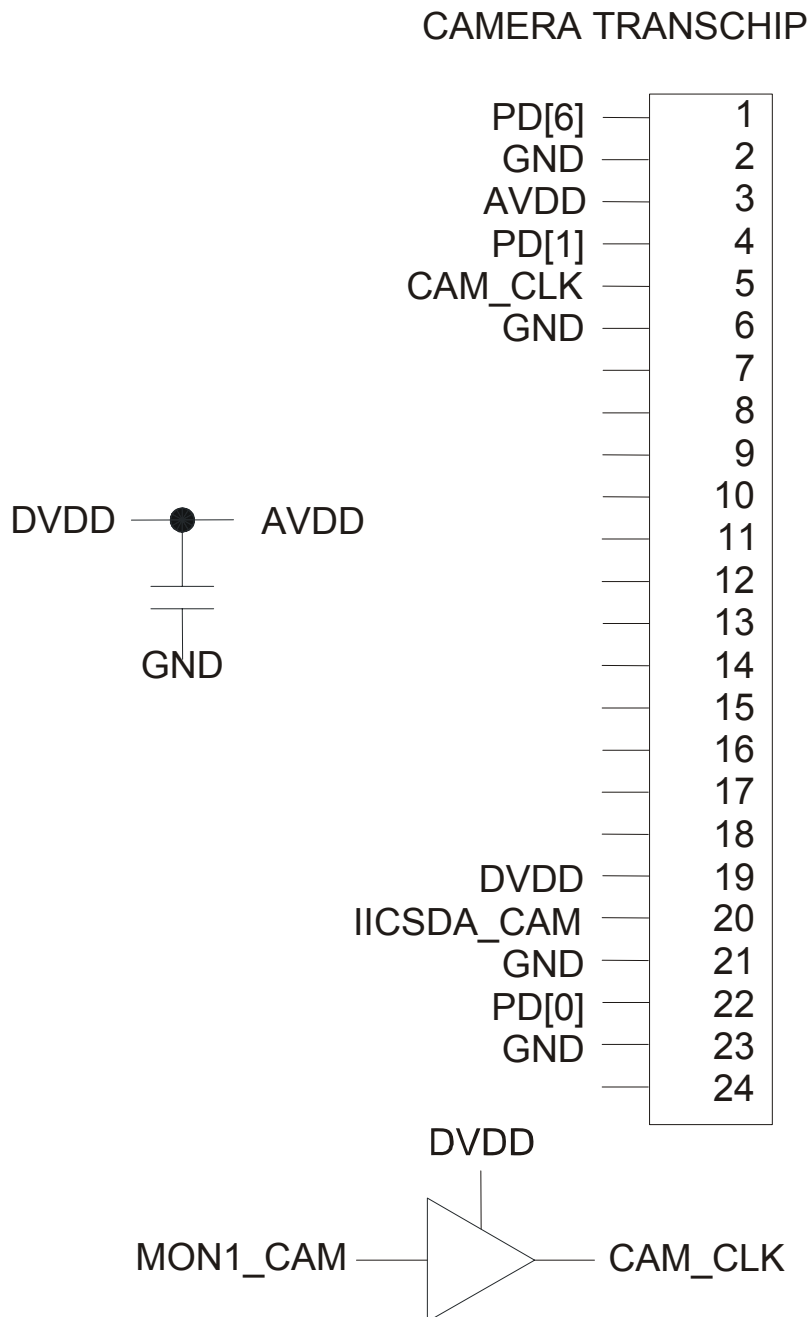

10.1.5 Schematic Diagrams for supported cameras

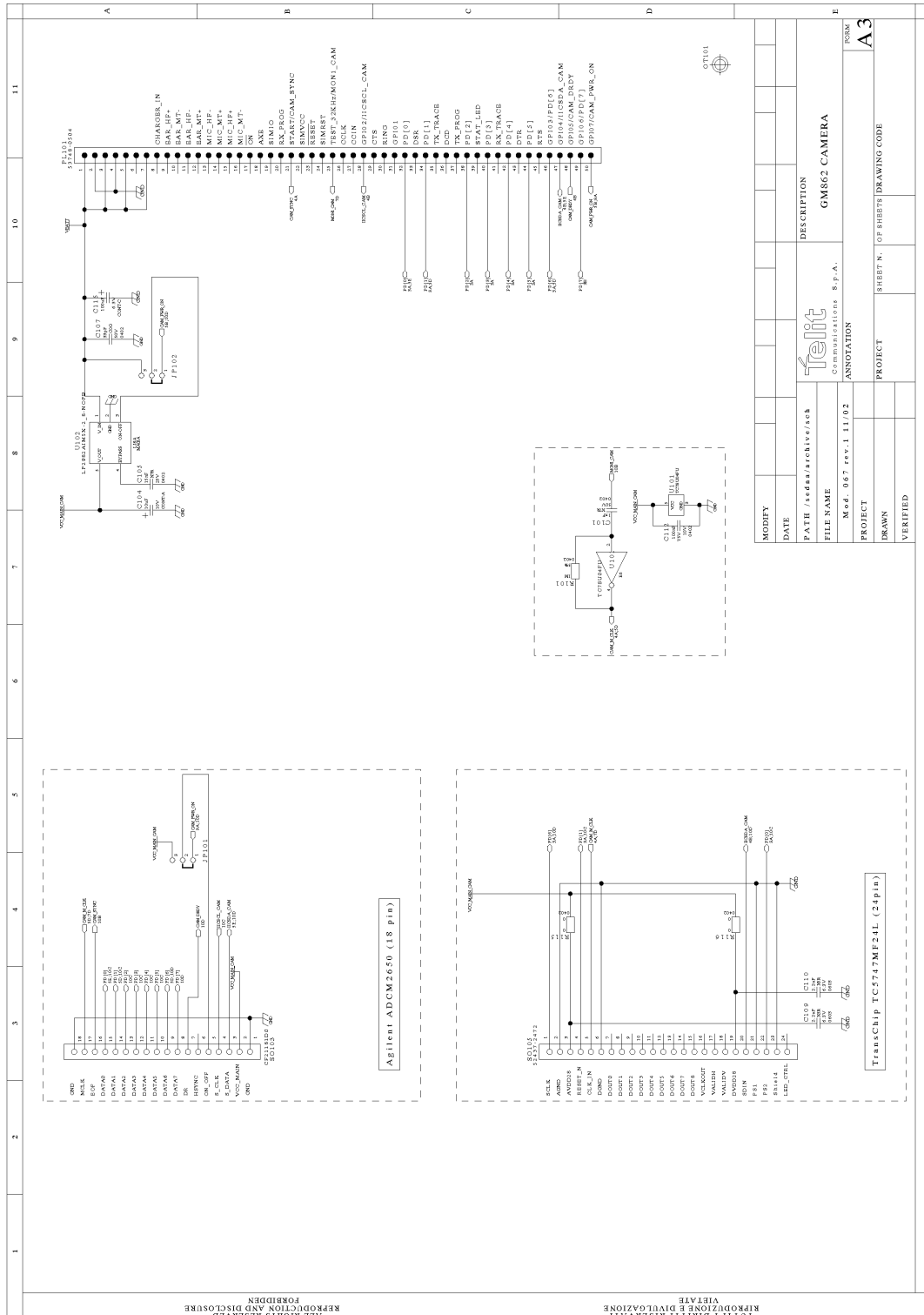

| | |
|--------------------|-----------------------|
| MODIFY | |
| DATE | |
| DESCRIPTION | GM862 CAMERA |
| FILE NAME | Communications S.p.A. |
| PROJECT | |
| DRAWN | |
| VERIFIED | |
| ANNOTATION | |
| SHEET N. OF SHEETS | DRAWING CODE |
| A3 | |



10.1.6 Example usage script for camera

Camera setting: (shown here are the defaults ones)

```

>AT#CAMSEL=0      (camera selection: 0-auto, 1-agilent, 2-transchip)
OK
>AT#CMODE=0       (camera mode: 0-day, 1-night)
OK
>AT#CAMQUA=0      (camera quality: 0-low, 1-medieum, 2-high)
OK
>AT#CAMRES=0      (camera resolution: 0-VGA, 1-QVGA, 2-QQVGA)
OK
>AT#CAMCOL=0*     (camera color: 0-color, 1-grayscale)
OK
>AT#CAMZOOM=0     (camera zoom: 0-x1, 1-x2, 2-x4)
OK
>AT#CAMTXT=0*     (camera timestamp: 0-no, 1-time only, 2-data only, 3-time&data)
OK
  
```

Taking an reading a photo:

```

>AT#CAMEN=1      (camera ON)
OK
>AT#TPHOTO       (take photo)
OK
>AT+OBJL?        (see photo dimension)
#OBJL: Snapshot,38900 (where 38900 is the file dimension in bytes of the photo taken)
OK
>AT#RPHOTO       (download the photo)
...data.....      (where ...data... Correspond to the photo data in binary)
OK
>AT#TPHOTO
OK
>AT#RPHOTO
...data.....
OK
>AT#CAMEN=0     (camera OFF)
  
```

*only Transchip camera

Repeating photo capture and download n times



11 Conformity Assessment Issues

The GM862-QUAD & GM862-QUAD-PY module is assessed to be conforming to the R&TTE Directive as stand-alone products so if the module is installed in conformance with Telit Communications installation instructions require no further evaluation under Article 3.2 of the R&TTE Directive and do not require further involvement of a R&TTE Directive Notified Body for the final product.

In all other cases, or if the manufacturer of the final product is in doubt then the equipment integrating the radio module must be assessed against Article 3.2 of the R&TTE Directive.

In all cases assessment of the final product must be made against the Essential requirements of the R&TTE Directive Articles 3.1(a) and (b), safety and EMC respectively, and any relevant Article 3.3 requirements.

The GM862-QUAD & GM862-QUAD-PY module is conform with the following European Union Directives:

- R&TTE Directive 1999/5/EC (Radio Equipment & Telecommunications Terminal Equipments)
- Low Voltage Directive 73/23/EEC and product safety
- Directive 89/336/EEC for conformity for EMC

In order to satisfy the essential requisite of the R&TTE 99/5/EC directive, the GM862-QUAD & GM862-QUAD-PY module is compliant with the following standards:

- GSM (Radio Spectrum). Standard: EN 301 511 and 3GPP 51.010-1
- EMC (Electromagnetic Compatibility). Standards: EN 301 489-1 and EN 301 489-7
- LVD (Low Voltage Directive) Standards: EN 60 950

In this document and the Hardware User Guide, Software User Guide all the information you may need for developing a product meeting the R&TTE Directive is included. The GM862-QUAD & GM862-QUAD-PY module is conform with the following US Directives:

- Use of RF Spectrum. Standards: FCC 47 Part 24 (GSM 1900)
- EMC (Electromagnetic Compatibility). Standards: FCC47 Part 15

To meet the FCC's RF exposure rules and regulations:

- The system antenna(s) used for this transmitter must be installed to provide a separation distance of at least 20 cm from all the persons and must not be co-located or operating in conjunction with any other antenna or transmitter.
- The system antenna(s) used for this module must not exceed 3 dBi for mobile and fixed or mobile operating configurations.
- Users and installers must be provided with antenna installation instructions and transmitter operating conditions for satisfying RF exposure compliance.

Manufacturers of mobile, fixed or portable devices incorporating this module are advised to clarify any regulatory questions and to have their complete product tested and approved for FCC compliance.



12 Document Change Log

| Revision | Date | Changes |
|----------|----------|---|
| ISSUE#0 | 16/10/06 | Release First ISSUE# 0 |
| ISSUE#1 | 24/10/06 | Added chapter 11 (Conformity assessment Issues) |
| | | |
| | | |
| | | |
| | | |
| | | |
| | | |

