

FCC 47 CFR PART 22H and 24E

Test Report

Product Type : GE910-QUAD V3
Applicant : Telit Communications S.p.A.
Address : Viale Stazione di Prosecco 5/b, Trieste, 34010, Italy
Trade Name : Telit
Model Number : GE910-QUAD V3
Test Specification : FCC 47 CFR PART 22H: Oct, 2012
FCC 47 CFR PART 24E: Oct, 2012
CANADA RSS-132 ISSUE 3: Jan. 2013
CANADA RSS-133 ISSUE 6: Jan. 2013
Canada RSS-Gen ISSUE 3: Dec., 2010
ANSI/TIA-603-C-2004
Application Purpose : Original
Receive Date : Jul. 08, 2013
Test Period : Jul. 11, 2013
Issue Date : Oct. 17, 2013

Issue by

A Test Lab Techno Corp.
No. 140-1, Changan Street, Bade City,
Taoyuan County 334, Taiwan R.O.C.
Tel : +886-3-2710188 / Fax : +886-3-2710190



Taiwan Accreditation Foundation accreditation number: 1330

Note: This report shall not be reproduced except in full, without the written approval of A Test Lab Techno Corp. This document may be altered or revised by A Test Lab Techno Corp. personnel only, and shall be noted in the revision section of the document. The client should not use it to claim product endorsement by TAF, or any government agencies. The test results in the report only apply to the tested sample.

Revision History

Rev.	Issue Date	Revisions	Revised By
00	Jul. 24, 2013	Initial Issue	
01	Oct. 17, 2013	Revised product type	Nico Peng

Verification of Compliance

Issued Date: 10/17/2013

Product Type : GE910-QUAD V3
Applicant : Telit Communications S.p.A.
Address : Viale Stazione di Prosecco 5/b, Trieste, 34010, Italy
Trade Name : Telit
Model Number : GE910-QUAD V3
FCC ID : R17GE910Q3
IC : 5131A-GE910Q3
EUT Rated Voltage : DC 3.4V / 3.8V / 4.2V
Test Voltage : DC 3.8V
Applicable Standard : FCC 47 CFR PART 22H: Oct, 2012
FCC 47 CFR PART 24E: Oct, 2012
CANADA RSS-132 ISSUE 3: Jan. 2013
CANADA RSS-133 ISSUE 6: Jan. 2013
Canada RSS-Gen ISSUE 3: Dec., 2010
ANSI/TIA-603-C-2004
Application Purpose : Original
Test Result : Complied
Performing Lab. : A Test Lab Techno Corp.
No. 140-1, Changan Street, Bade City,
Taoyuan County 334, Taiwan R.O.C.
Tel : +886-3-2710188 / Fax : +886-3-2710190
Taiwan Accreditation Foundation accreditation number: 1330
<http://www.atl-lab.com.tw/e-index.htm>



The above equipment was tested by A Test Lab Techno Corp. The test data, data evaluation, test procedures, and equipment configurations shown in this report were made in accordance with the procedures given in ANSI C63.4: 2009 and the energy emitted by the sample tested as described in this report is in compliance with the requirements of FCC Rules Part 22H, Part 24E.

The test results of this report relate only to the tested sample identified in this report.

Approved By :  Reviewed By : 
(Manager) (Murphy Wang) (Testing Engineer) (Fly Lu)

TABLE OF CONTENTS

1	General Information	6
1.1.	EUT Description	6
1.2.	Mode of Operation.....	6
1.3.	EUT Exercise Software	6
1.4.	Configuration of Test System Details	7
1.5.	Test Site Environment	7
1.6.	Summary of Test Result	8
2	RF Output Power Test	9
2.1.	Limit	9
2.2.	Test Instruments	9
2.3.	Test Setup.....	9
2.4.	Test Procedure	9
2.5.	Uncertainty	9
2.6.	Test Result.....	10
3	Effective Radiated Power / Equivalent Isotropic Radiated Power Test.....	11
3.1.	Limit	11
3.2.	Test Instruments	11
3.3.	Setup	11
3.4.	Test Procedure	13
3.5.	Uncertainty	13
3.6.	Test Result.....	14
4	Occupied Bandwidth Test	15
4.1.	Limit	15
4.2.	Test Instruments	15
4.3.	Setup	15
4.4.	Test Procedure	16
4.5.	Uncertainty	16
4.6.	Test Result.....	16
4.7.	Test Graphs	17
5	Band Edge Test	19
5.1.	Limit	19
5.2.	Test Instruments	19
5.3.	Setup	19
5.4.	Test Procedure	20
5.5.	Uncertainty	20
5.6.	Test Result.....	20
5.7.	Test Graphs	21

6	Conducted Spurious Emission Test	23
6.1.	Limit	23
6.2.	Test Instruments	23
6.3.	Setup	23
6.4.	Test Procedure	24
6.5.	Uncertainty	24
6.6.	Test Result.....	24
7	Field Strength of Spurious Radiation Test	58
7.1.	Limit	58
7.2.	Test Instruments	58
7.3.	Setup	59
7.4.	Test Procedure	59
7.5.	Uncertainty	60
7.6.	Test Result.....	61
8	Frequency Stability (Temperature & Voltage Variation) Test	68
8.1.	Limit	68
8.2.	Test Instruments	68
8.3.	Setup	68
8.4.	Test Procedure	69
8.5.	Uncertainty	69
8.6.	Test Result.....	70

1 General Information

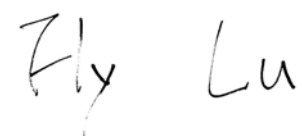
1.1. EUT Description

Applicant	Telit Communications S.p.A.				
Applicant Address	Viale Stazione di Prosecco 5/b, Trieste, 34010, Italy				
Manufacturer	Telit Communications S.p.A.				
Manufacturer Address	Via Stazione di Prosecco, 5/B 34010 Sgonico Italy				
Product Type	GE910-QUAD V3				
Trade Name	Telit				
Model Number	GE910-QUAD V3				
FCC ID	R17GE910Q3				
IC	5131A-GE910Q3				
IMEI No.	359785029004598				
Mode	GSM/GPRS	Band	UL Frequency (MHz)	DL Frequency (MHz)	Modulation
		850	824.2 ~ 848.8	869.2 ~ 893.8	GMSK/8PSK
		1900	1850.2 ~ 1909.8	1930.2 ~ 1989.8	GMSK/8PSK
Channel Control	Auto				
Type of Antenna	1/41 Mobile Antenna				
Antenna Gain (dBi)	GSM/GPRS 850 : 6.43 dBi GSM/GPRS 1900 : 3.00 dBi				
Max. RF Output power	GSM/GPRS 850 : 32.33 dBm / 1.710 W GSM/GPRS 1900 : 30.31 dBm / 1.074 W				
Max. ERP/EIRP	GSM/GPRS 850 : 29.11 dBm / 0.815 W GSM/GPRS 1900 : 28.79 dBm / 0.757 W				
Emission Designator	GSM/GPRS 850 : 248KGXW GSM/GPRS 1900 : 244KGXW				

1.2. Mode of Operation

ATL has verified the construction and function in typical operation. All the test modes were carried out with the EUT in normal operation, which was shown in this test report and defined as:

Test Mode
Mode 1: GSM 850 Link Mode
Mode 2: GSM 1900 Link Mode
Mode 3: Receive Link Mode

Note: Regards to the frequency band operation: the lowest, middle and highest frequency of channel were selected to perform the test, then shown on this report.

1.3. EUT Exercise Software

1	Setup the EUT and Base Station (CMU200) as shown on 1.4.
2	Turn on the power of all equipment.

1.4. Configuration of Test System Details

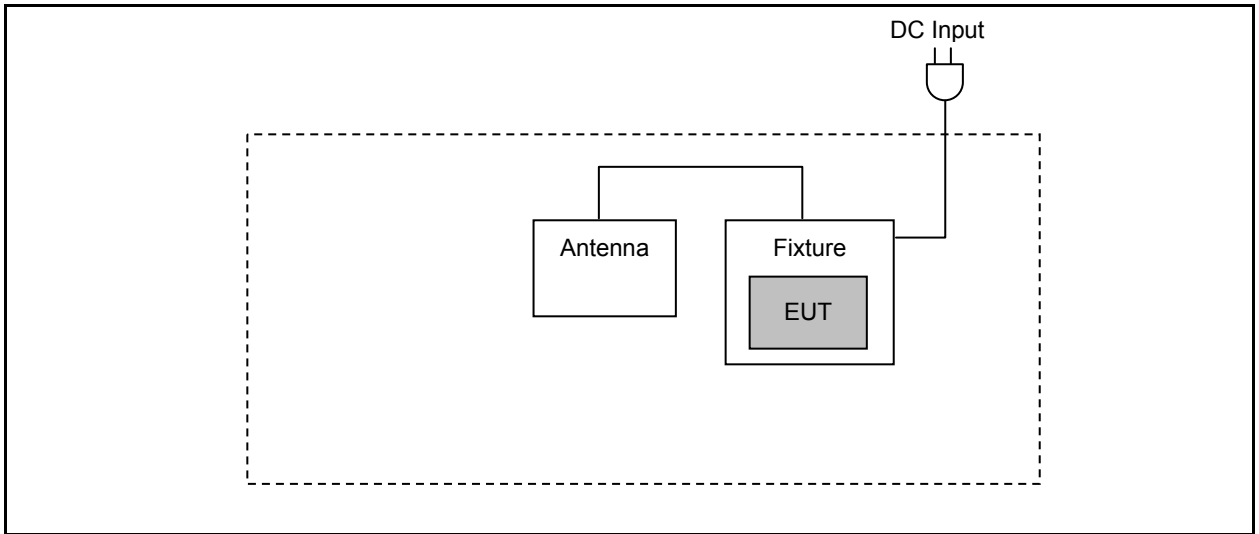

1.5. Test Site Environment

Items	Required (IEC 68-1)	Actual
Temperature (°C)	15-35	26
Humidity (%RH)	25-75	60
Barometric pressure (mbar)	860-1060	950

1.6. Summary of Test Result

Description	FCC Rule	IC Rule	Limit	Result
Conducted Output Power	§2.1046	N/A	N/A	Pass
Effective Radiated Power	§22.913(a)(2)	RSS-132(4.4) SRSP-503(5.1.3)	< 7 Watts for FCC (<6.3 Watts for IC)	Pass
Equivalent Isotropic Radiated Power	§24.232(c)	RSS-133 (6.4) SRSP-510(5.1.2)	< 2 Watts	Pass
Occupied Bandwidth	§2.1049 §22.917(a) §24.238(a)	RSS-Gen (4.6.1)	N/A	Pass
Band Edge Measurement	§2.1051 §22.917(a) §24.238(a)	RSS-132 (4.5.1)RSS-133 (6.5.1)	< 43+10log ₁₀ (P[Watts])	Pass
Conducted Spurious Emission	§2.1051 §22.917(a) §24.238(a)	RSS-132 (4.5.1) RSS-133 (6.5.1)	< 43+10log ₁₀ (P[Watts])	Pass
Field Strength of Spurious Radiation	§2.1053 §22.917(a) §24.238(a)	RSS-132 (4.5.1) RSS-133 (6.5.1) RSS-Gen (4.10)	< 43+10log ₁₀ (P[Watts])	Pass
Frequency Stability for Temperature & Voltage	§2.1055 §22.355 §24.235	RSS-132(4.3) RSS-133(6.3)	< 2.5 ppm	Pass

2 RF Output Power Test

2.1. Limit

N/A

2.2. Test Instruments

Equipment	Manufacturer	Model Number	Serial Number	Cal. Date	Remark
Universal Radio Communication Tester	R & S	CMU200	109369	08/07/2012	(2)
Single Channel PK Power Sensor	Agilent	N1911A	MY45101619	12/15/2011	(2)
Wideband Power Meter	Agilent	N1921A	MY45241957	12/15/2011	(2)
Test Site	ATL	TE05	TE05	N.C.R.	-----

Remark: ⁽¹⁾ Calibration period 1 year. ⁽²⁾ Calibration period 2 years.

Note: N.C.R. = No Calibration Request.

2.3. Test Setup

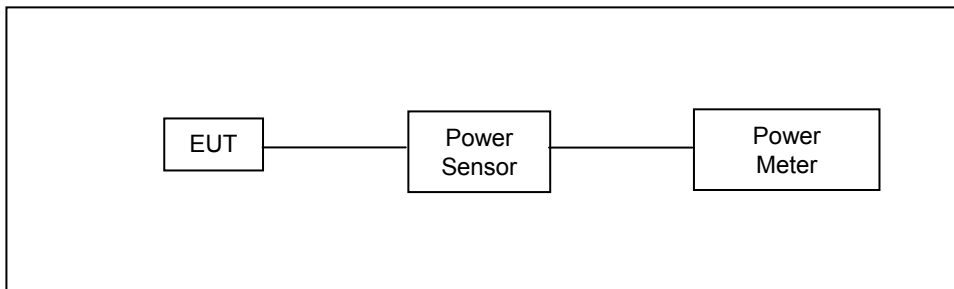

2.4. Test Procedure

The measurement is made according to ANSI/TIA-603-C-2004 as follows:

1. The transmitter output was connected to power meter and base station through Power Divider.
2. Set base station for EUT at GSM 850: PCL=5 and PCS 1900: PCL=0.
3. Set base station for EUT at WCDMA Band V and WCDMA Band II, power level was set to maximum.
4. Select lowest, middle, and highest channels for each band.

2.5. Uncertainty

The measurement uncertainty is defined as for RF output power measurement is 1.2 dB.

2.6. Test Result

Model Number	GE910-QUAD V3						
Test Item	RF Output Power						
Date of Test	07/11/2013			Test Site		TE05	
Bands	Modulation Type	Data Rate	Frequency (MHz)	Burst Average Power		Peak Power	
				(dBm)	(W)	(dBm)	(W)
GSM 850	GMSK	-----	824.2	32.13	1.633	32.33	1.710
			836.6	32.10	1.622	32.30	1.698
			848.8	32.08	1.614	32.27	1.687
GRRS 850 Multi Class :10 Max Up:2 Max Down:4 Sum:5	GMSK	4Down1Up (Duty Factor 1/8)	824.2	32.10	1.622	32.28	1.690
			836.6	32.06	1.607	32.27	1.687
			848.8	32.00	1.585	32.20	1.660
		3Down2Up (Duty Factor 2/8)	824.2	31.68	1.472	31.94	1.563
			836.6	31.59	1.442	31.83	1.524
			848.8	31.45	1.396	31.71	1.483

Note: The peak power testing result was used peak detector.

Model Number	GE910-QUAD V3						
Test Item	RF Output Power						
Date of Test	07/11/2013			Test Site		TE05	
Bands	Modulation Type	Data Rate	Frequency (MHz)	Burst Average Power		Peak Power	
				(dBm)	(W)	(dBm)	(W)
GSM 1900	GMSK	-----	1850.20	30.11	1.026	30.31	1.074
			1880.00	29.96	0.991	30.14	1.033
			1909.80	29.81	0.957	29.92	0.982
GRRS 1900 Multi Class :10 Max Up:2 Max Down:4 Sum:5	GMSK	4Down1Up (Duty Factor 1/8)	1850.20	29.93	0.984	30.13	1.030
			1880.00	29.81	0.957	29.98	0.995
			1909.80	29.69	0.931	29.81	0.957
		3Down2Up (Duty Factor 2/8)	1850.20	29.72	0.938	29.94	0.986
			1880.00	29.58	0.908	29.76	0.946
			1909.80	29.41	0.873	29.59	0.910

Note: The peak power testing result was used peak detector.

3 Effective Radiated Power / Equivalent Isotropic Radiated Power Test

3.1. Limit

For FCC Part 22.913(a)(2): The ERP of mobile transmitters and auxiliary test transmitters must not exceed 7 Watts.

For FCC Part 24.232(b): The EIRP of mobile transmitters and auxiliary test transmitters must not exceed 2 Watts.

3.2. Test Instruments

3 Meter Chamber					
Equipment	Manufacturer	Model Number	Serial Number	Cal. Date	Remark
RF Pre-selector	Agilent	N9039A	MY46520256	01/21/2013	(2)
Spectrum Analyzer	Agilent	E4446A	MY46180578	01/21/2013	(1)
Pre Amplifier	Agilent	8449B	3008A02237	02/21/2013	(1)
Pre Amplifier	Agilent	8447D	2944A10961	02/21/2013	(1)
Broadband Antenna (30MHz~1GHz)	SCHWARZBECK MESS-ELEKTRONIK	VULB9163	9163-270	07/01/2013	(1)
Horn Antenna (1~18GHz)	SCHWARZBECK MESS-ELEKTRONIK	BBHA9120D	9120D-550	06/10/2013	(1)
Horn Antenna (18~40GHz)	SCHWARZBECK MESS-ELEKTRONIK	BBHA9170	9170-320	06/13/2013	(1)
Test Site	ATL	TE01	888001	08/28/2012	(1)

Remark: ⁽¹⁾ Calibration period 1 year. ⁽²⁾ Calibration period 2 years.

Note: N.C.R. = No Calibration Request.

3.3. Setup

Below 1 GHz

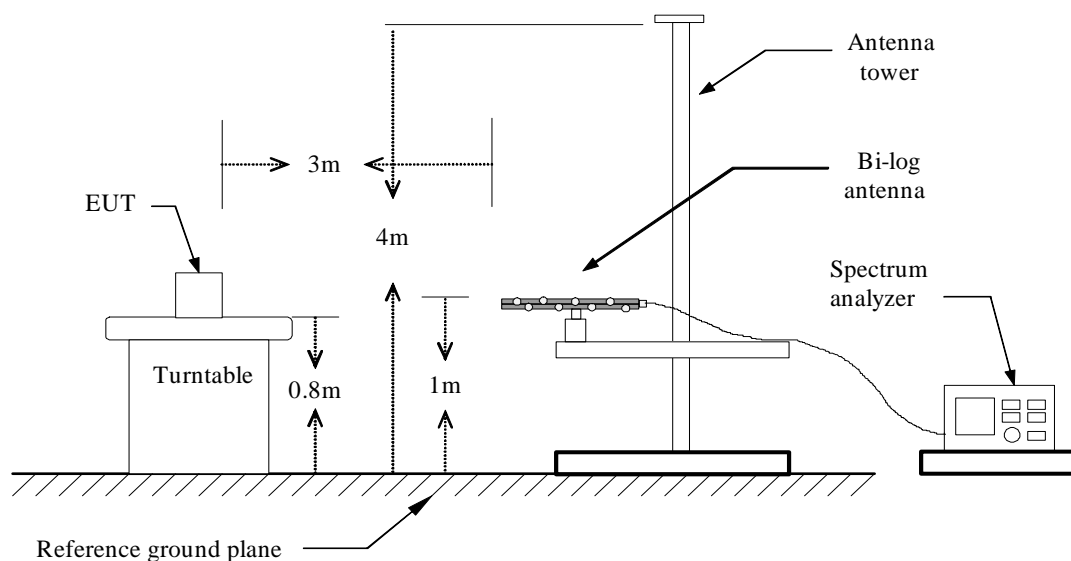

Above 1 GHz

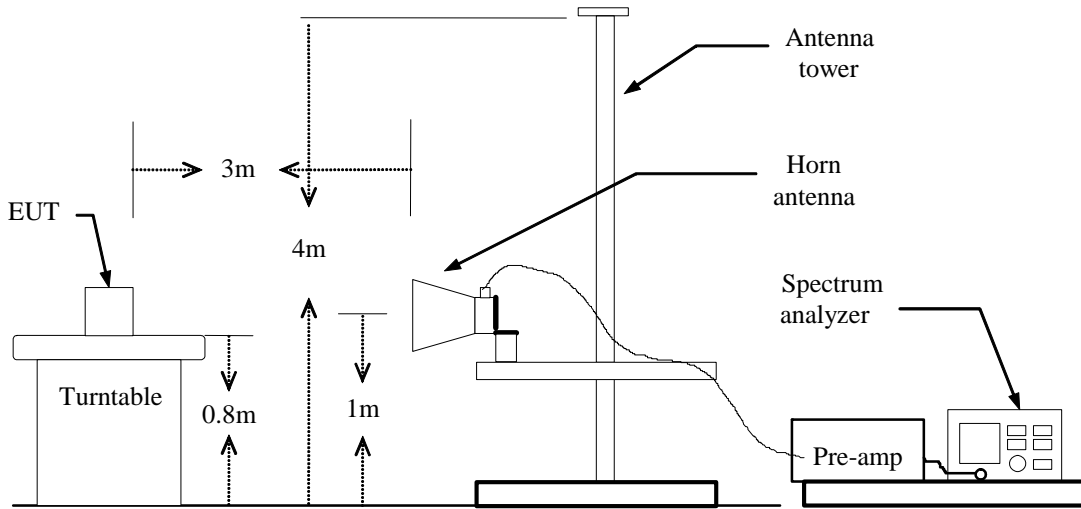

For Substituted Method Test Set-UP

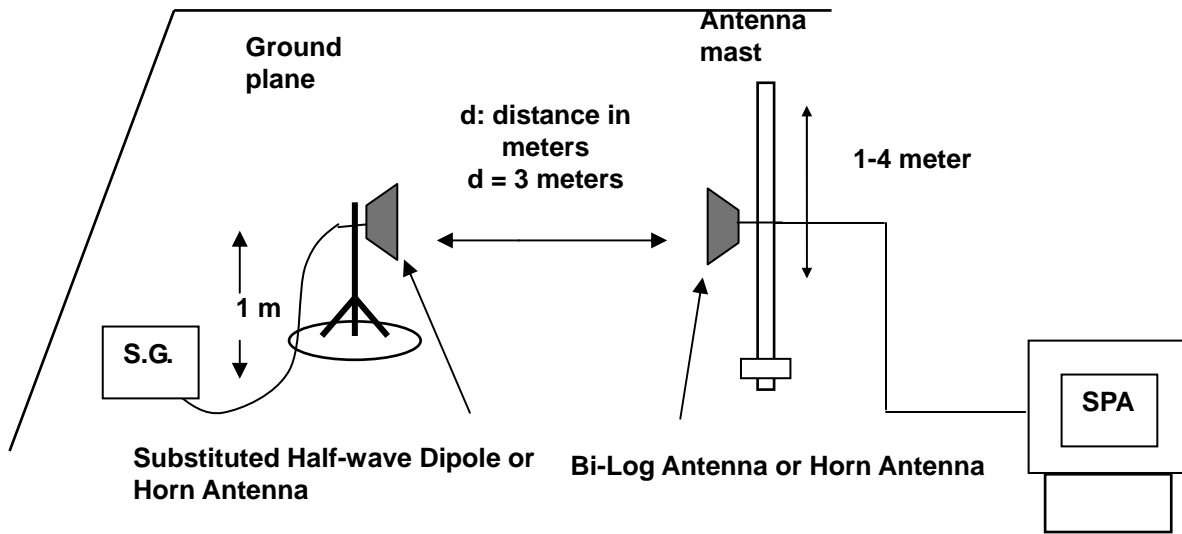

3.4. Test Procedure

The measurement is made according to ANSI/TIA-603-C-2004 as follows:

The EUT was placed on a non-conductive turntable using a non-conductive support. The radiated emission at the fundamental frequency was measured at 3 m with a test antenna and EMI spectrum analyzer.

During the measurement of the EUT, the resolution bandwidth was set to 3MHz and the average bandwidth was set to 3MHz. The highest emission was recorded with the rotation of the turntable and the lowering of the test antenna.

The reading was recorded and the field strength (E in dBuV/m) was calculated.

ERP in frequency band 824-849MHz, and EIRP in frequency band 1851.25 –1910MHz were measured using a substitution method. The EUT was replaced by half-wave dipole (824-849MHz) or horn antenna (1851.25-1910MHz) connected to a signal generator. The spectrum analyzer reading was recorded and ERP/EIRP was calculated as follows:

ERP = S.G. output (dBm) + Antenna Gain (dBd) – Cable (dB)

EIRP = S.G. output (dBm) + Antenna Gain (dBi) – Cable (dB)

3.5. Uncertainty

The measurement uncertainty is defined as for Field Strength of Spurious Radiation measurement is ± 3.072 dB.

3.6. Test Result

Model Number	GE910-QUAD V3								
Test Item	ERP/EIRP								
Date of Test	07/11/2013					Test Site	TE01		
Bands	Modulation Type	Frequency (MHz)	Ant. Polar.	Read Level (dBm)	Correction Factor (dBm)	ERP		Limit	
						(dBm)	(W)		
GSM 850	GMSK	824.2	H	14.90	11.29	26.19	0.416	< 7W	
			V	17.82	11.29	29.11	0.815	< 7W	
		836.6	H	16.28	11.34	27.62	0.578	< 7W	
			V	17.60	11.34	28.94	0.783	< 7W	
		848.8	H	15.66	11.47	27.13	0.516	< 7W	
			V	17.50	11.47	28.97	0.789	< 7W	

Model Number	GE910-QUAD V3								
Test Item	ERP/EIRP								
Date of Test	07/11/2013					Test Site	TE01		
Bands	Modulation Type	Frequency (MHz)	Ant. Polar.	Read Level (dBm)	Correction Factor (dBm)	EIRP		Limit	
						(dBm)	(W)		
GSM 1900	GMSK	1850.20	H	15.38	11.39	26.77	0.475	< 2W	
			V	17.40	11.39	28.79	0.757	< 2W	
		1880.00	H	15.52	11.65	27.17	0.521	< 2W	
			V	16.91	11.65	28.56	0.718	< 2W	
		1909.80	H	15.05	11.91	26.96	0.497	< 2W	
			V	16.73	11.91	28.64	0.731	< 2W	

Note: 1. ERP/EIRP = Read Level + Correction factor.

2. For WCDMA signals, a peak detector is used with RBW = VBW = 5MHz.

3. For AMPS, GSM, and NADC TDMA signals, a peak detector is used, with RBW = VBW= 1 MHz.

4 Occupied Bandwidth Test

4.1. Limit

The Occupied Bandwidth Limit:

N/A.

4.2. Test Instruments

Equipment	Manufacturer	Model Number	Serial Number	Cal. Date	Remark
Universal Radio Communication Tester	R & S	CMU200	109369	08/07/2012	(2)
Spectrum Analyzer	Agilent	E4445A	MY46181986	05/16/2013	(1)
Attenuator	RADIALL	R41572000	0603033073	N.C.R.	-----
Power Divider	Agilent	87302C	3239A00760	N.C.R.	-----
Test Site	ATL	TE05	TE05	N.C.R.	-----

Remark: ⁽¹⁾ Calibration period 1 year. ⁽²⁾ Calibration period 2 years.

Note: N.C.R. = No Calibration Request.

4.3. Setup

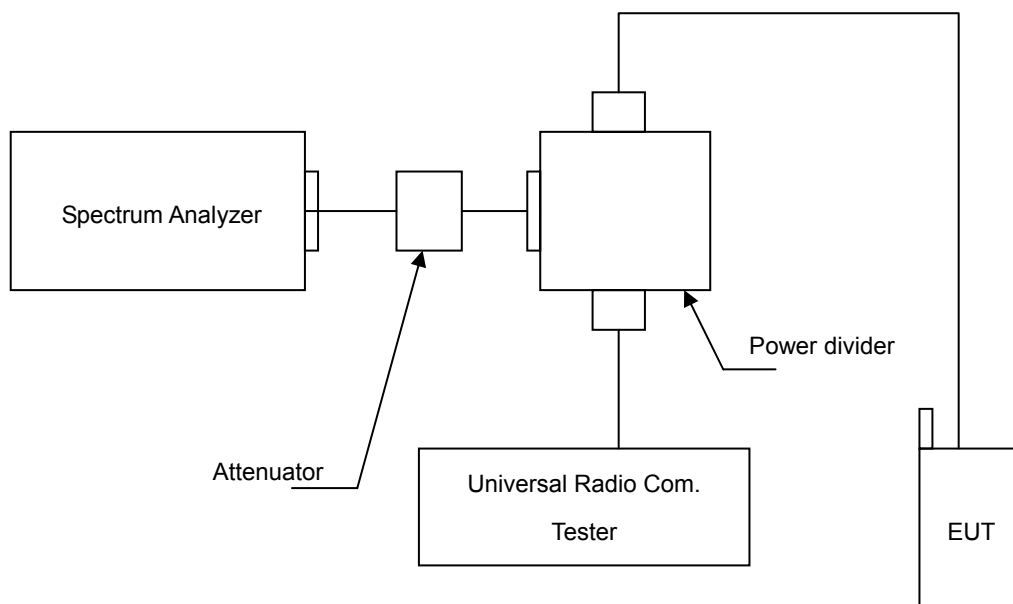

4.4. Test Procedure

The measurement is made according to FCC rules part 22 and 24:

1. The EUT was connected to Spectrum Analyzer and Base Station via Power Divider.
2. The occupied bandwidth of middle channel for the highest and lowest RF powers was measured.



4.5. Uncertainty

The measurement uncertainty is defined as $\pm 10\text{Hz}$

4.6. Test Result

Model Number	GE910-QUAD V3				
Test Item	Occupied Bandwidth				
Date of Test	07/11/2013			Test Site	TE05
Bands	Channel	Frequency (MHz)	99% Bandwidth (kHz)	Note	
GSM 850	128	824.2	247.5590	RBW:10KHz , VBW:30KHz	
	190	836.6	248.1235	RBW:10KHz , VBW:30KHz	
	251	848.8	242.3647	RBW:10KHz , VBW:30KHz	
GSM 1900	512	1850.20	244.4962	RBW:10KHz , VBW:30KHz	
	661	1880.00	240.2024	RBW:10KHz , VBW:30KHz	
	810	1909.80	244.1355	RBW:10KHz , VBW:30KHz	

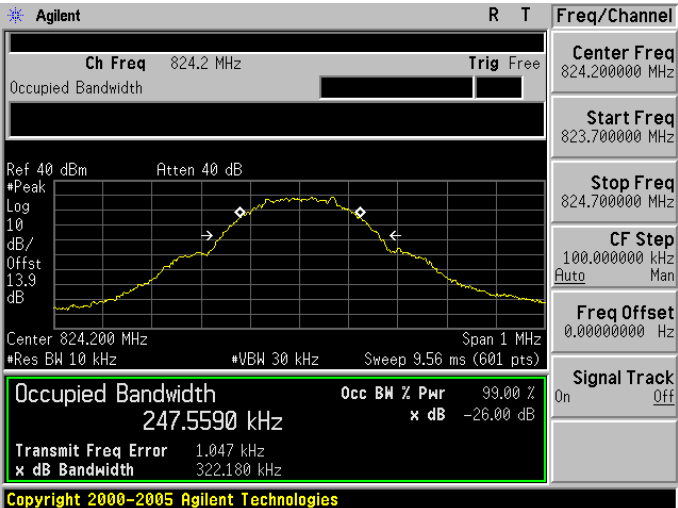
4.7. Test Graphs

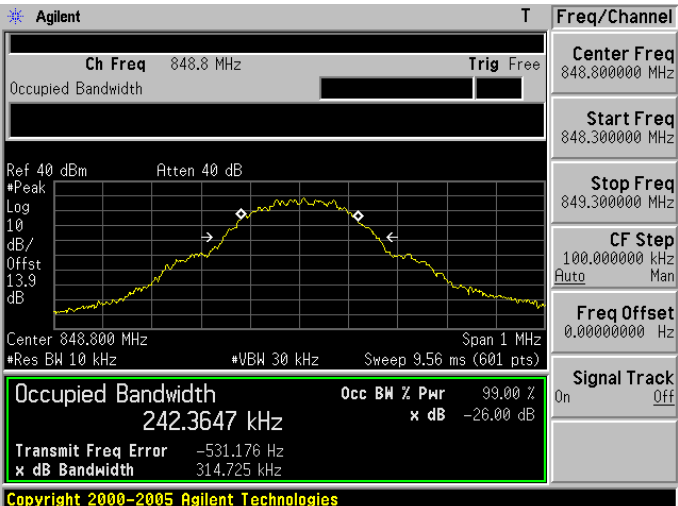
Mode 1: GSM 850 Link Mode	
824.2 MHz	 <p>Agilent R T Freq/Channel</p> <p>Ch Freq 824.2 MHz Trig Free</p> <p>Center Freq 824.200000 MHz</p> <p>Start Freq 823.700000 MHz</p> <p>Stop Freq 824.700000 MHz</p> <p>CF Step 100.000000 kHz Auto Man</p> <p>Freq Offset 0.00000000 Hz</p> <p>Signal Track On Off</p> <p>Ref 40 dBm Atten 40 dB</p> <p>Peak</p> <p>Log</p> <p>10 dB/Offst 13.9 dB</p> <p>Center 824.200 MHz Span 1 MHz</p> <p>Res BW 10 kHz VBW 30 kHz Sweep 9.56 ms (601 pts)</p> <p>Occupied Bandwidth 247.5590 kHz Occ BW % Pwr 99.00 % x dB -26.00 dB</p> <p>Transmit Freq Error 1.047 kHz x dB Bandwidth 322.180 kHz</p> <p>Copyright 2000-2005 Agilent Technologies</p>
836.6 MHz	 <p>Agilent T Freq/Channel</p> <p>Ch Freq 836.6 MHz Trig Free</p> <p>Center Freq 836.600000 MHz</p> <p>Start Freq 836.100000 MHz</p> <p>Stop Freq 837.100000 MHz</p> <p>CF Step 100.000000 kHz Auto Man</p> <p>Freq Offset 0.00000000 Hz</p> <p>Signal Track On Off</p> <p>Ref 40 dBm Atten 40 dB</p> <p>Peak</p> <p>Log</p> <p>10 dB/Offst 13.9 dB</p> <p>Center 836.600 MHz Span 1 MHz</p> <p>Res BW 10 kHz VBW 30 kHz Sweep 9.56 ms (601 pts)</p> <p>Occupied Bandwidth 248.1235 kHz Occ BW % Pwr 99.00 % x dB -26.00 dB</p> <p>Transmit Freq Error 170.526 Hz x dB Bandwidth 318.706 kHz</p> <p>Copyright 2000-2005 Agilent Technologies</p>
848.8 MHz	 <p>Agilent T Freq/Channel</p> <p>Ch Freq 848.8 MHz Trig Free</p> <p>Center Freq 848.800000 MHz</p> <p>Start Freq 848.300000 MHz</p> <p>Stop Freq 849.300000 MHz</p> <p>CF Step 100.000000 kHz Auto Man</p> <p>Freq Offset 0.00000000 Hz</p> <p>Signal Track On Off</p> <p>Ref 40 dBm Atten 40 dB</p> <p>Peak</p> <p>Log</p> <p>10 dB/Offst 13.9 dB</p> <p>Center 848.800 MHz Span 1 MHz</p> <p>Res BW 10 kHz VBW 30 kHz Sweep 9.56 ms (601 pts)</p> <p>Occupied Bandwidth 242.3647 kHz Occ BW % Pwr 99.00 % x dB -26.00 dB</p> <p>Transmit Freq Error -531.176 Hz x dB Bandwidth 314.725 kHz</p> <p>Copyright 2000-2005 Agilent Technologies</p>

Mode 2: GSM 1900 Link Mode	
1850.20 MHz	<p>Agilent T</p> <p>Ch Freq 1.8502 GHz Trig Free</p> <p>Occupied Bandwidth</p> <p>Ref 40 dBm Atten 40 dB</p> <p>*Peak</p> <p>Log</p> <p>10 dB/Offst 14.7 dB</p> <p>Center 1.850 200 GHz Span 1 MHz</p> <p>*Res BW 10 kHz #VBW 30 kHz Sweep 9.56 ms (601 pts)</p> <p>Occupied Bandwidth 244.4962 kHz</p> <p>Occ BW % Pwr 99.00 % x dB -26.00 dB</p> <p>Transmit Freq Error 193.592 Hz</p> <p>x dB Bandwidth 315.877 kHz</p> <p>Copyright 2000-2005 Agilent Technologies</p> <p>Freq/Channel</p> <p>Center Freq 1.85020000 GHz</p> <p>Start Freq 1.84970000 GHz</p> <p>Stop Freq 1.85070000 GHz</p> <p>CF Step 100.000000 kHz Auto Man</p> <p>Freq Offset 0.00000000 Hz</p> <p>Signal Track On Off</p>
1880.00 MHz	<p>Agilent T</p> <p>Ch Freq 1.88 GHz Trig Free</p> <p>Occupied Bandwidth</p> <p>Ref 40 dBm Atten 40 dB</p> <p>*Peak</p> <p>Log</p> <p>10 dB/Offst 14.7 dB</p> <p>Center 1.880 000 GHz Span 1 MHz</p> <p>*Res BW 10 kHz #VBW 30 kHz Sweep 9.56 ms (601 pts)</p> <p>Occupied Bandwidth 240.2024 kHz</p> <p>Occ BW % Pwr 99.00 % x dB -26.00 dB</p> <p>Transmit Freq Error 1.301 kHz</p> <p>x dB Bandwidth 317.687 kHz</p> <p>Copyright 2000-2005 Agilent Technologies</p> <p>Freq/Channel</p> <p>Center Freq 1.88000000 GHz</p> <p>Start Freq 1.87950000 GHz</p> <p>Stop Freq 1.88050000 GHz</p> <p>CF Step 100.000000 kHz Auto Man</p> <p>Freq Offset 0.00000000 Hz</p> <p>Signal Track On Off</p>
1909.80 MHz	<p>Agilent T</p> <p>Ch Freq 1.9098 GHz Trig Free</p> <p>Occupied Bandwidth</p> <p>Ref 40 dBm Atten 40 dB</p> <p>*Peak</p> <p>Log</p> <p>10 dB/Offst 14.7 dB</p> <p>Center 1.909 800 GHz Span 1 MHz</p> <p>*Res BW 10 kHz #VBW 30 kHz Sweep 9.56 ms (601 pts)</p> <p>Occupied Bandwidth 244.1355 kHz</p> <p>Occ BW % Pwr 99.00 % x dB -26.00 dB</p> <p>Transmit Freq Error 564.502 Hz</p> <p>x dB Bandwidth 313.958 kHz</p> <p>Copyright 2000-2005 Agilent Technologies</p> <p>Freq/Channel</p> <p>Center Freq 1.90980000 GHz</p> <p>Start Freq 1.90930000 GHz</p> <p>Stop Freq 1.91030000 GHz</p> <p>CF Step 100.000000 kHz Auto Man</p> <p>Freq Offset 0.00000000 Hz</p> <p>Signal Track On Off</p>

5 Band Edge Test

5.1. Limit

The Band Edge Limit:

The power of any emission outside of the authorized operating frequency ranges must be attenuated below the transmitting power (P) by a factor of at least $43 + 10\log(P)$ dB.

5.2. Test Instruments

Equipment	Manufacturer	Model Number	Serial Number	Cal. Date	Remark
Universal Radio Communication Tester	R & S	CMU200	109369	08/07/2012	(2)
Spectrum Analyzer	Agilent	E4445A	MY46181986	05/16/2013	(1)
Attenuator	RADIALL	R41572000	0603033073	N.C.R.	-----
Power Divider	Agilent	87302C	3239A00760	N.C.R.	-----
Test Site	ATL	TE05	TE05	N.C.R.	-----

Remark: ⁽¹⁾ Calibration period 1 year. ⁽²⁾ Calibration period 2 years.

Note: N.C.R. = No Calibration Request.

5.3. Setup

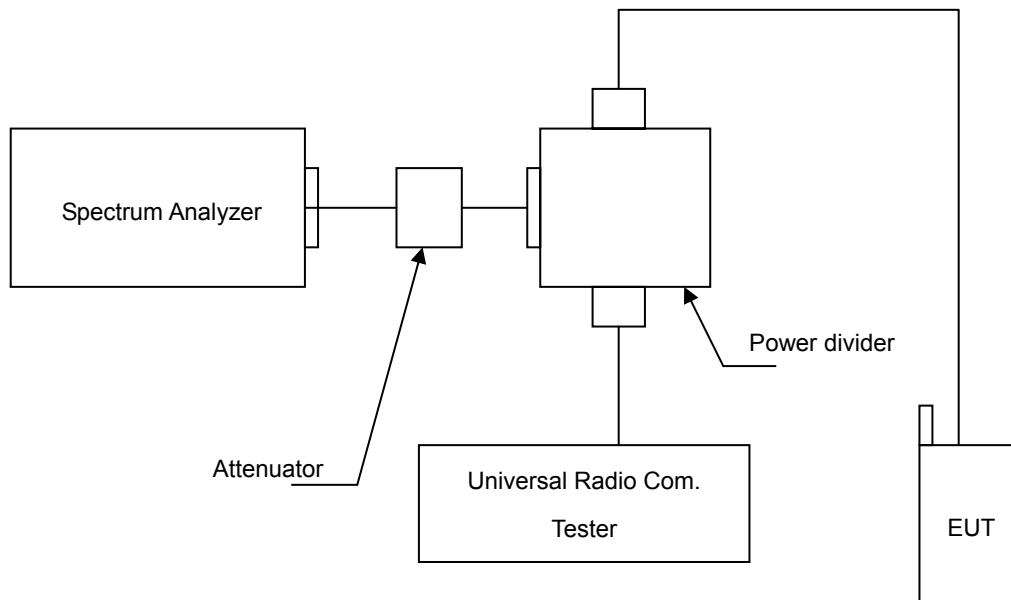

5.4. Test Procedure

The measurement is made according to FCC rules part 22 and 24:

3. The EUT was connected to Spectrum Analyzer and Base Station via Power Divider.
4. The band edge of low and high channels for the highest RF powers within the transmitting frequency band were measured. Setting RBW as roughly BW/100.
5. The band edge setting:
 - a. RB=10 kHz; VB=30 kHz for GSM 850 and PCS 1900.
 - b. RB=100 kHz; VB=300 kHz for WCDMA Band V and WCDMA Band II.

5.5. Uncertainty

The measurement uncertainty is defined as $\pm 10\text{Hz}$

5.6. Test Result

Model Number		GE910-QUAD V3				
Test Item		Band Edge				
Date of Test		07/11/2013			Test Site	TE05
Bands		Channel	Frequency (MHz)	Bandwidth (dBm)	Limit (dBm)	Result
GSM 850	Lower	128	824.0000	-15.05	-13	Pass
	Higher	251	849.0000	-15.20	-13	Pass
GSM 1900	Lower	512	1850.000	-26.12	-13	Pass
	Higher	810	1910.000	-24.25	-13	Pass

5.7. Test Graphs

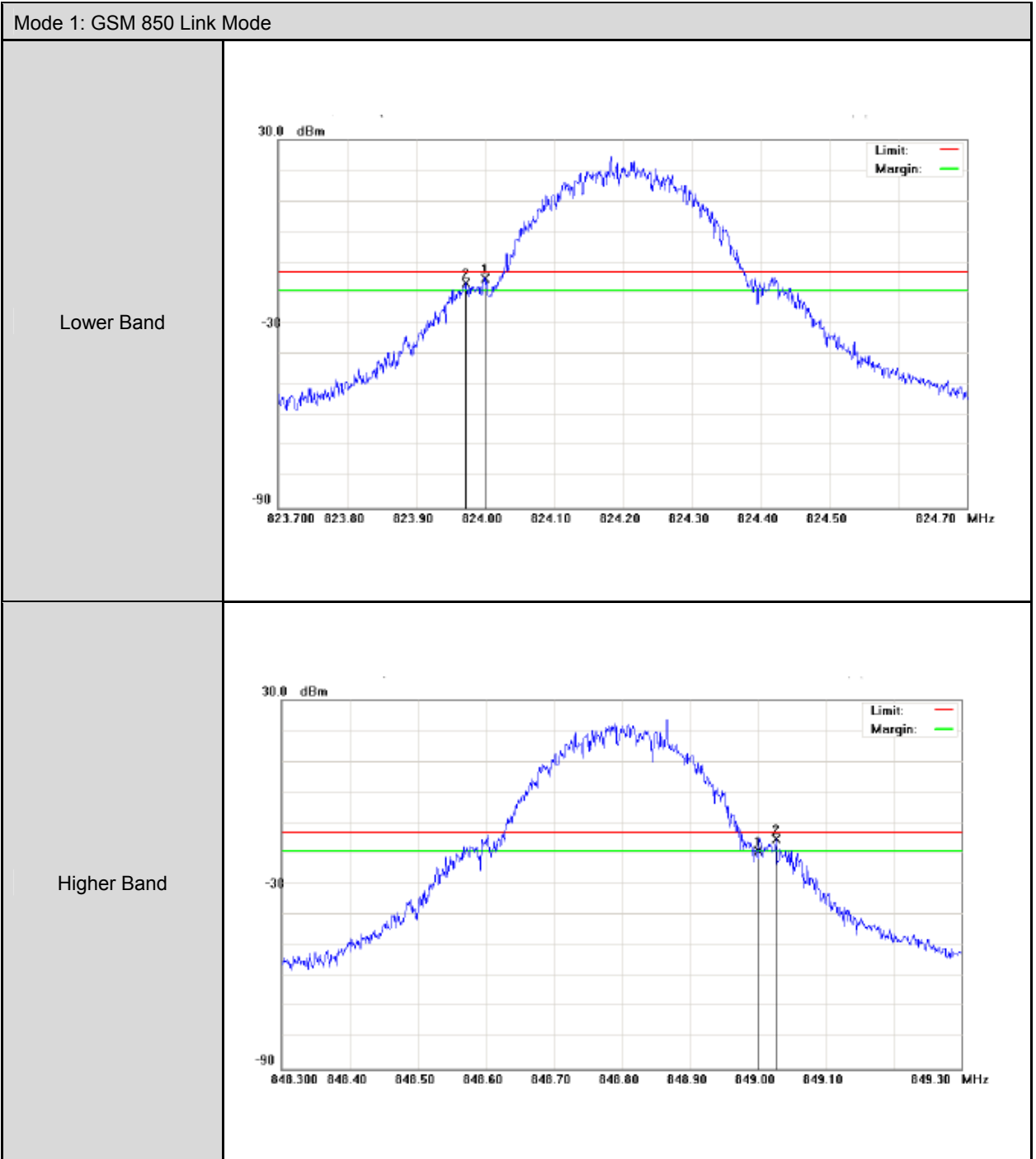

Mode 2: GSM 1900 Link Mode

Lower Band

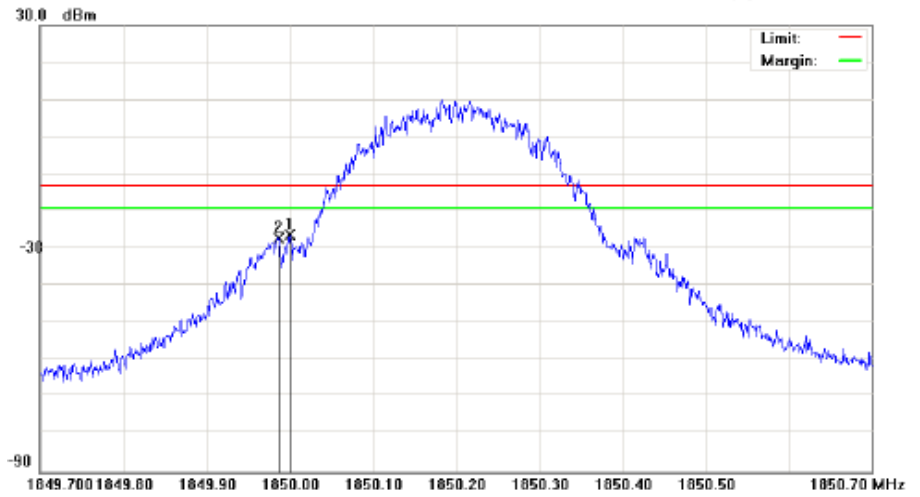

Higher Band

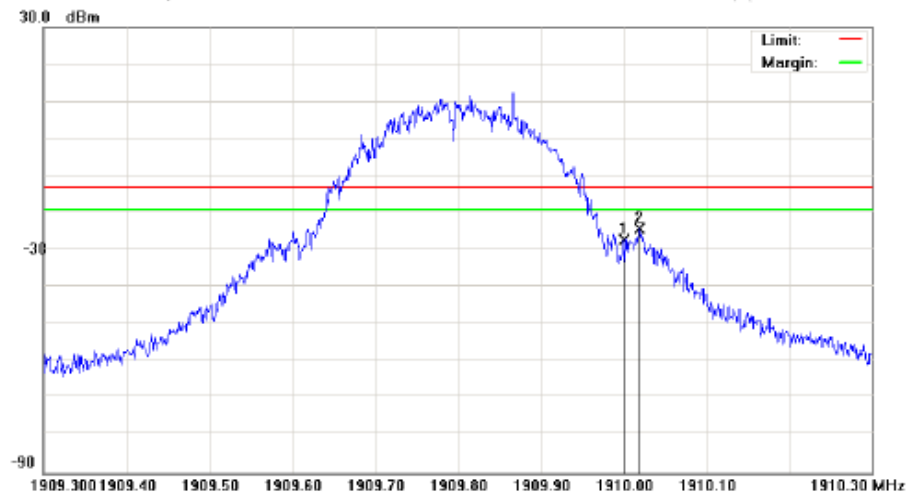

6 Conducted Spurious Emission Test

6.1. Limit

The power of any emission outside of the authorized operating frequency ranges must be attenuated below the transmitting power (P) by a factor of at least $43 + 10\log(P)$ dB.

6.2. Test Instruments

Equipment	Manufacturer	Model Number	Serial Number	Cal. Date	Remark
Universal Radio Communication Tester	R & S	CMU200	109369	08/07/2012	(2)
Spectrum Analyzer	Agilent	E4445A	MY46181986	05/16/2013	(1)
Attenuator	RADIALL	R41572000	0603033073	N.C.R.	-----
Power Divider	Agilent	87302C	3239A00760	N.C.R.	-----
Test Site	ATL	TE05	TE05	N.C.R.	-----

Remark: ⁽¹⁾ Calibration period 1 year. ⁽²⁾ Calibration period 2 years.

Note: N.C.R. = No Calibration Request.

6.3. Setup

Below 2.8GHz

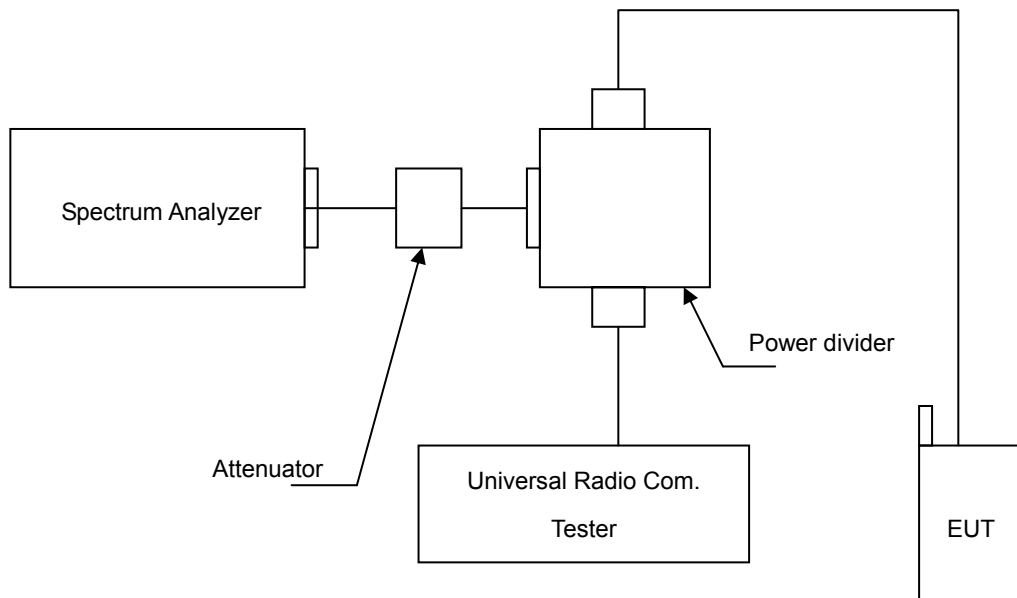

Above 2.8GHz

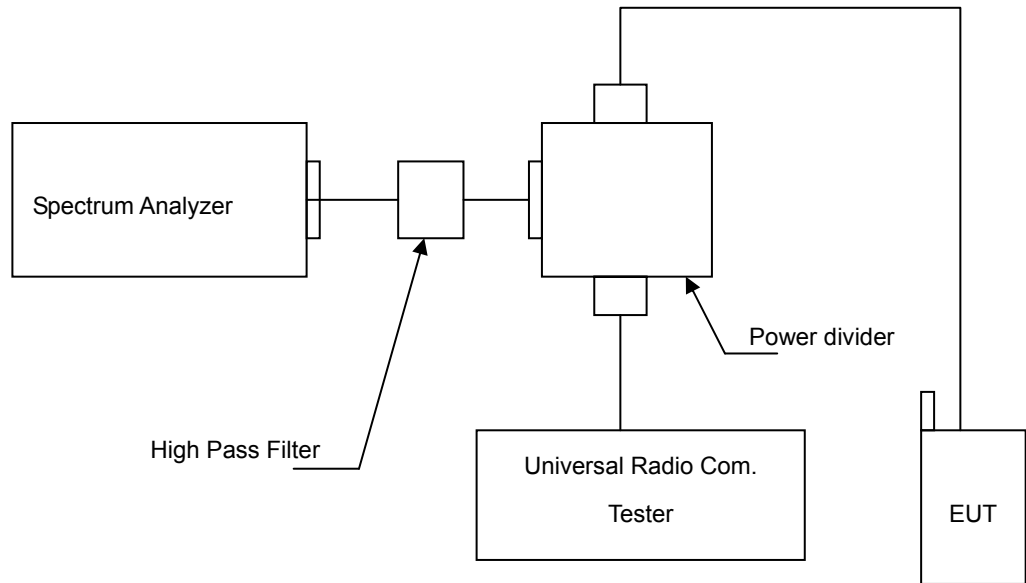

6.4. Test Procedure

1. The EUT was connected to Spectrum Analyzer and Base Station via Power Divider.
2. The middle channel for the highest RF power within the transmitting frequency was measured.
3. The conducted spurious emission for the whole frequency range was taken.
4. Test setting at GSM 850 RB>100 kHz, VB>100 kHz; PCS 1900 RB>1MHz, VB>1MHz.

6.5. Uncertainty

The measurement uncertainty is evaluated as ± 2.24 dB.

6.6. Test Result

Model Number	GE910-QUAD V3		
Test Item	Conducted Emission		
Test Mode	Mode 1 / Mode 2		
Date of Test	07/11/2013	Test Site	TE05

File :GE910-QUAD V3(CH128)

Data :#1

Date: 2013-7-11

Time: 下午 02:50:04

10.0 dBm

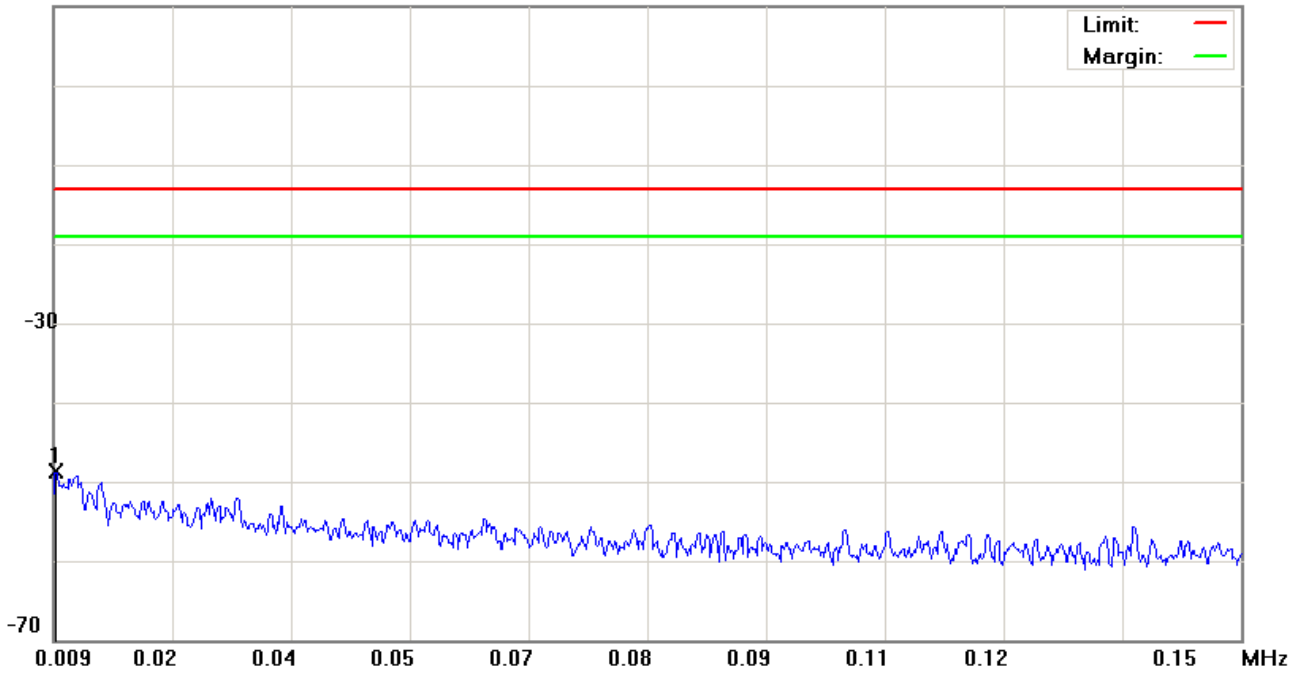

Site: site #1

Polarization: *Conducted po*

Temperature: 26 °C

Limit: FCC Part 22 conducted(9k-12.75G)

Power: DC 3.8V

Humidity: 55 %

EUT: GE910-QUAD V3

Distance:

RBW: 1 KHz VBW: 3 KHz

M/N: GE910-QUAD V3

Mode: GSM 850

Note:

No.	Mk.	Freq. MHz	Reading Level dBm	Correct Factor dB	Measure- ment dBm	Limit dBm	Over dB	Antenna Height cm	Table Degree degree	Comment
1	*	0.0093	-79.38	30.58	-48.80	-13.00	-35.80	peak		

*:Maximum data x:Over limit !:over margin

File :GE910-QUAD V3(CH128)

Data :#3

Date: 2013-7-11

Time: 下午 02:50:52

20.0 dBm

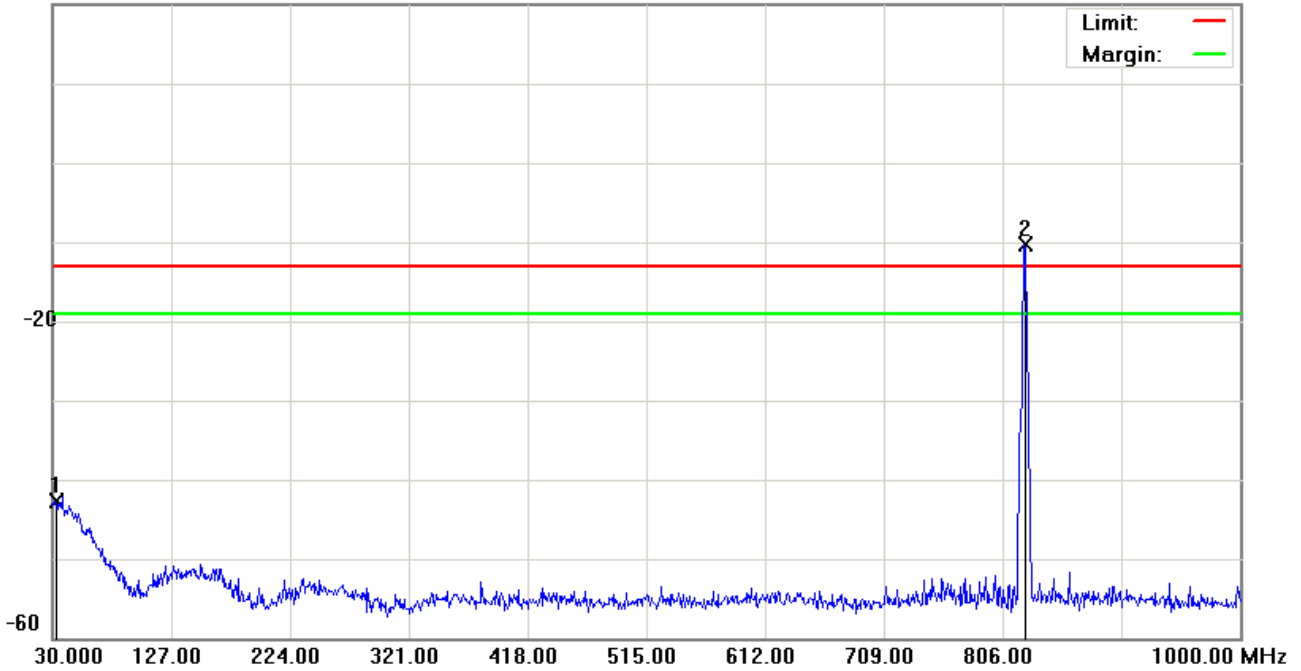

Site: site #1

Polarization: *Conducted po*

Temperature: 26 °C

Limit: FCC Part 22 conducted(9k-12.75G)

Power: DC 3.8V

Humidity: 55 %

EUT: GE910-QUAD V3

Distance:

RBW: 100 KHz VBW: 300 KHz

M/N: GE910-QUAD V3

Mode: GSM 850

Note:

No.	Mk.	Freq. MHz	Reading Level dBm	Correct Factor dB	Measure- ment dBm	Limit dBm	Over dB	Detector	Antenna Height cm	Table Degree degree	Comment
1		32.4250	-59.72	16.94	-42.78	-13.00	-29.78	peak			
2	*	823.9450	-14.15	3.83	-10.32	-13.00	2.68	peak			Tx

*:Maximum data x:Over limit !:over margin

File :GE910-QUAD V3(CH128)

Data :#4

Date: 2013-7-11

Time: 下午 03:01:17

0.0 dBm

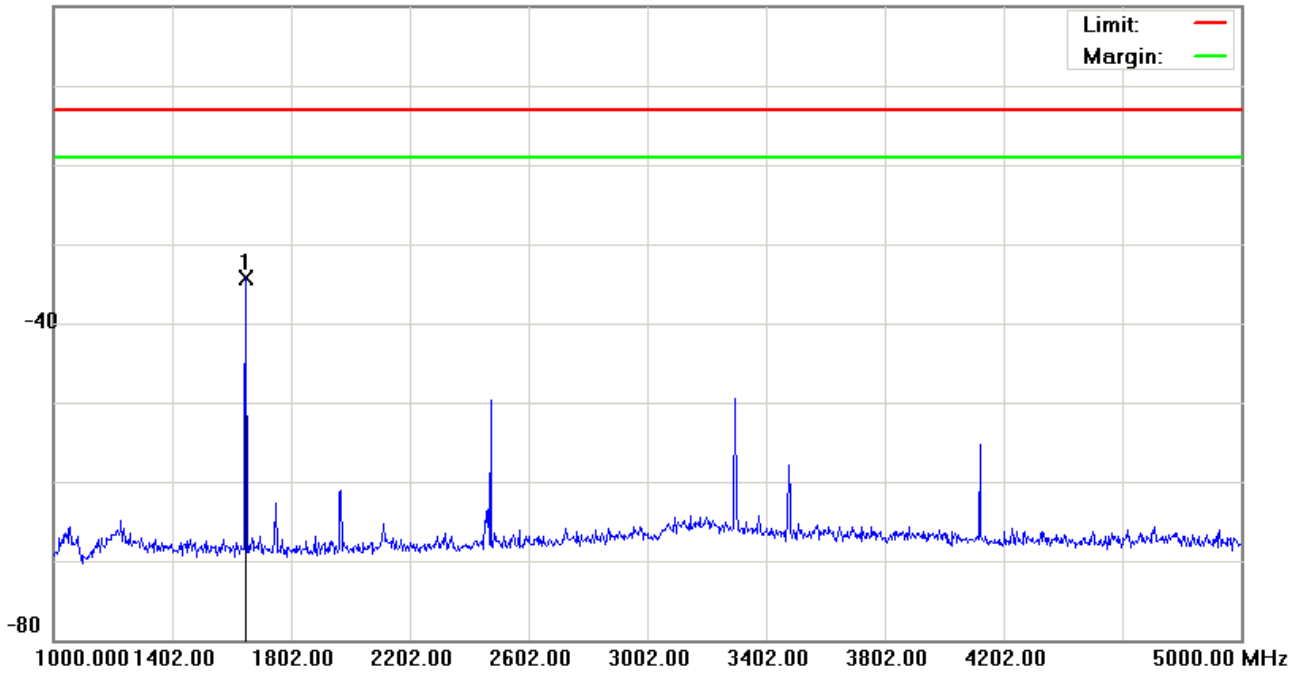

Site: site #1

Polarization: *Conducted po*

Temperature: 26 °C

Limit: FCC Part 22 conducted(9k-12.75G)

Power: DC 3.8V

Humidity: 55 %

EUT: GE910-QUAD V3

Distance:

RBW: 1000 KHz VBW: 3000 KHz

M/N: GE910-QUAD V3

Mode: GSM 850

Note:

No.	Mk.	Freq.	Reading Level	Correct Factor	Measurement	Limit	Over	Antenna Height	Table Degree		
		MHz	dBm	dB	dBm	dBm	dB	Detector	cm	degree	Comment
1	*	1648.000	-38.66	4.45	-34.21	-13.00	-21.21	peak			

*:Maximum data x:Over limit !:over margin

File :GE910-QUAD V3(CH190)

Data :#1

Date: 2013-7-11

Time: 下午 02:52:27

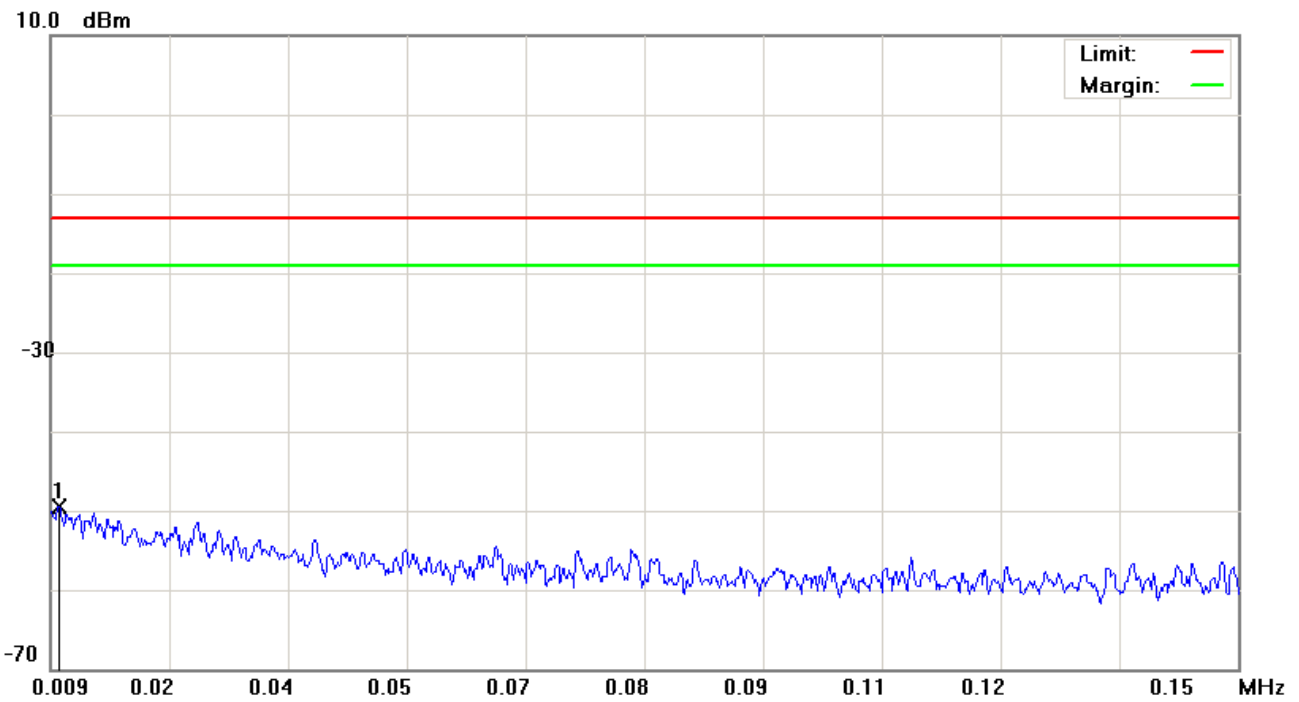

Site: site #1

Polarization: *Conducted po*

Temperature: 26 °C

Limit: FCC Part 22 conducted(9k-12.75G)

Power: DC 3.8V

Humidity: 55 %

EUT: GE910-QUAD V3

Distance:

RBW: 1 KHz VBW: 3 KHz

M/N: GE910-QUAD V3

Mode: GSM 850

Note:

No.	Mk.	Freq. MHz	Reading Level dBm	Correct Factor dB	Measure- ment dBm	Limit dBm	Over dB	Antenna Height cm	Table Degree degree	Comment
1	*	0.0100	-80.12	30.58	-49.54	-13.00	-36.54	peak		

*:Maximum data x:Over limit !:over margin

File :GE910-QUAD V3(CH190)

Data :#3

Date: 2013-7-11

Time: 下午 02:53:16

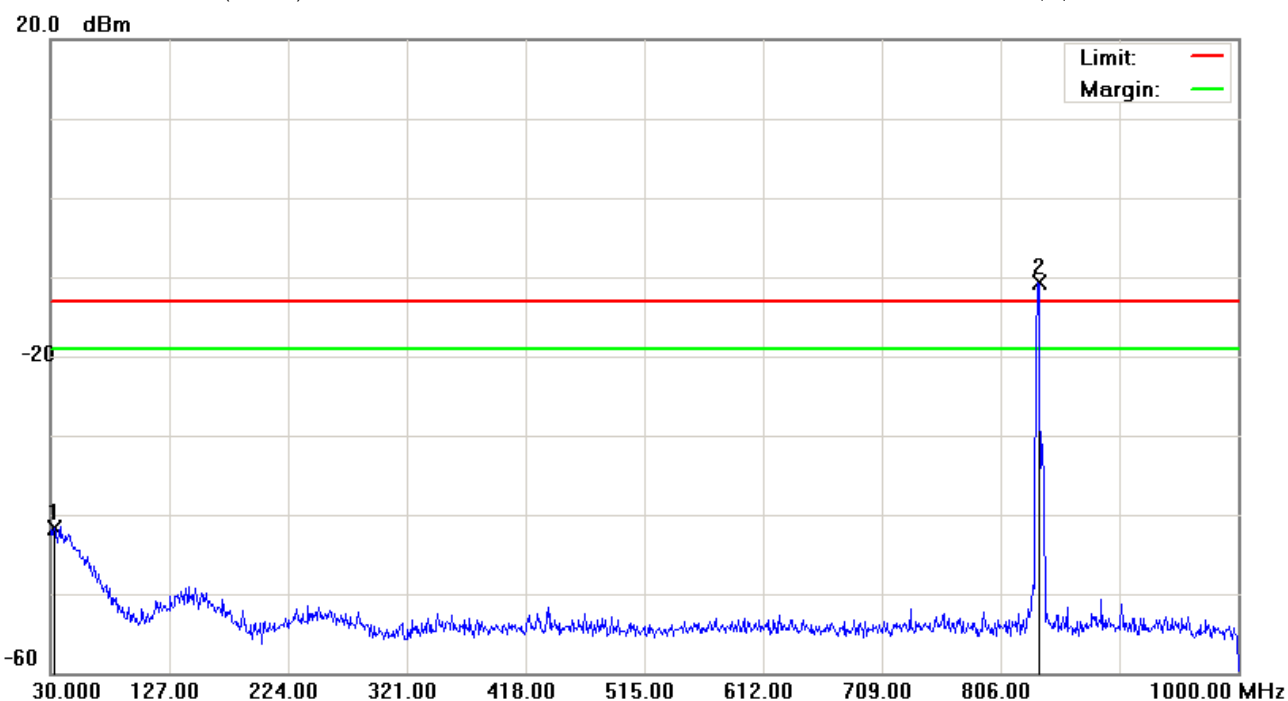

Site: site #1

Polarization: *Conducted po*

Temperature: 26 °C

Limit: FCC Part 22 conducted(9k-12.75G)

Power: DC 3.8V

Humidity: 55 %

EUT: GE910-QUAD V3

Distance:

RBW: 100 KHz VBW: 300 KHz

M/N: GE910-QUAD V3

Mode: GSM 850

Note:

No.	Mk.	Freq. MHz	Reading Level dBm	Correct Factor dB	Measure- ment dBm	Limit dBm	Over dB	Antenna Height cm	Table Degree degree	Comment
1		32.9100	-58.54	16.88	-41.66	-13.00	-28.66	peak		
2	*	836.5550	-14.57	3.96	-10.61	-13.00	2.39	peak		Tx

*:Maximum data x:Over limit !:over margin

File :GE910-QUAD V3(CH190)

Data :#4

Date: 2013-7-11

Time: 下午 03:03:04

0.0 dBm

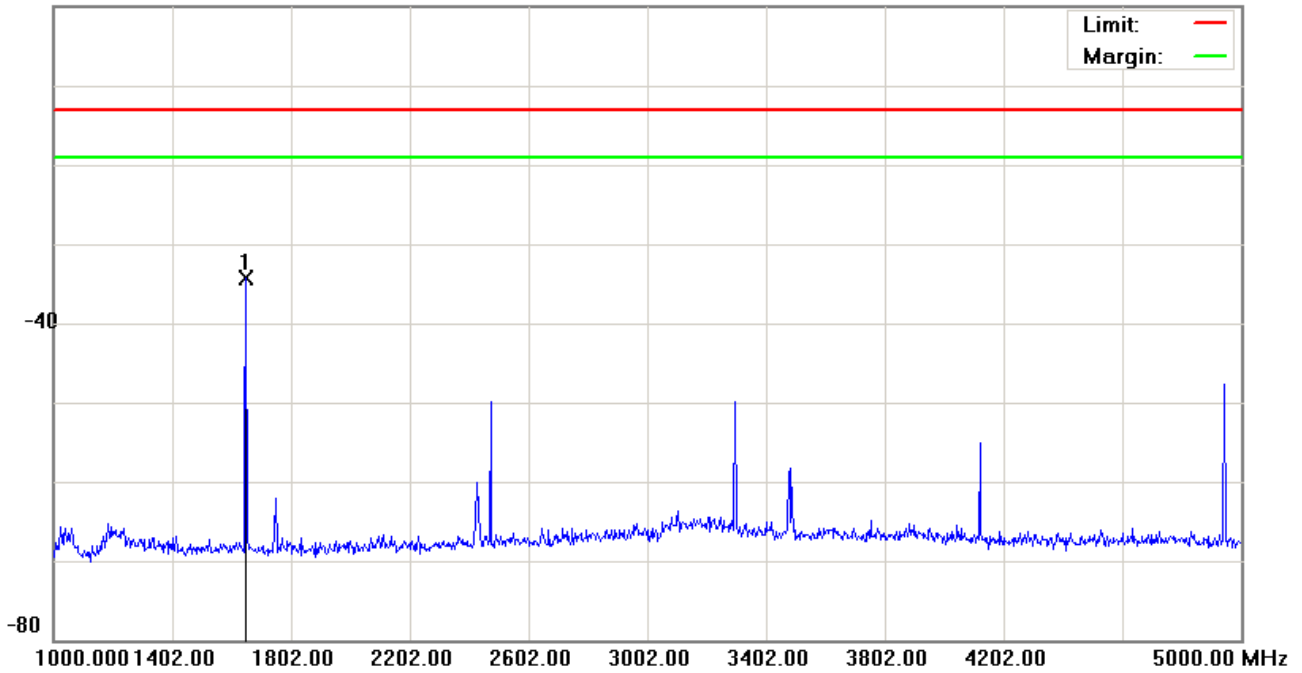

Site: site #1

Polarization: *Conducted po*

Temperature: 26 °C

Limit: FCC Part 22 conducted(9k-12.75G)

Power: DC 3.8V

Humidity: 55 %

EUT: GE910-QUAD V3

Distance:

RBW: 1000 KHz VBW: 3000 KHz

M/N: GE910-QUAD V3

Mode: GSM 850

Note:

No.	Mk.	Freq. MHz	Reading Level dBm	Correct Factor dB	Measure- ment dBm	Limit dBm	Over dB	Antenna Height cm	Table Degree degree	Comment
1	*	1648.000	-38.72	4.45	-34.27	-13.00	-21.27	peak		

*:Maximum data x:Over limit !:over margin

File :GE910-QUAD V3(CH251)

Data :#1

Date: 2013-7-11

Time: 下午 02:54:35

10.0 dBm

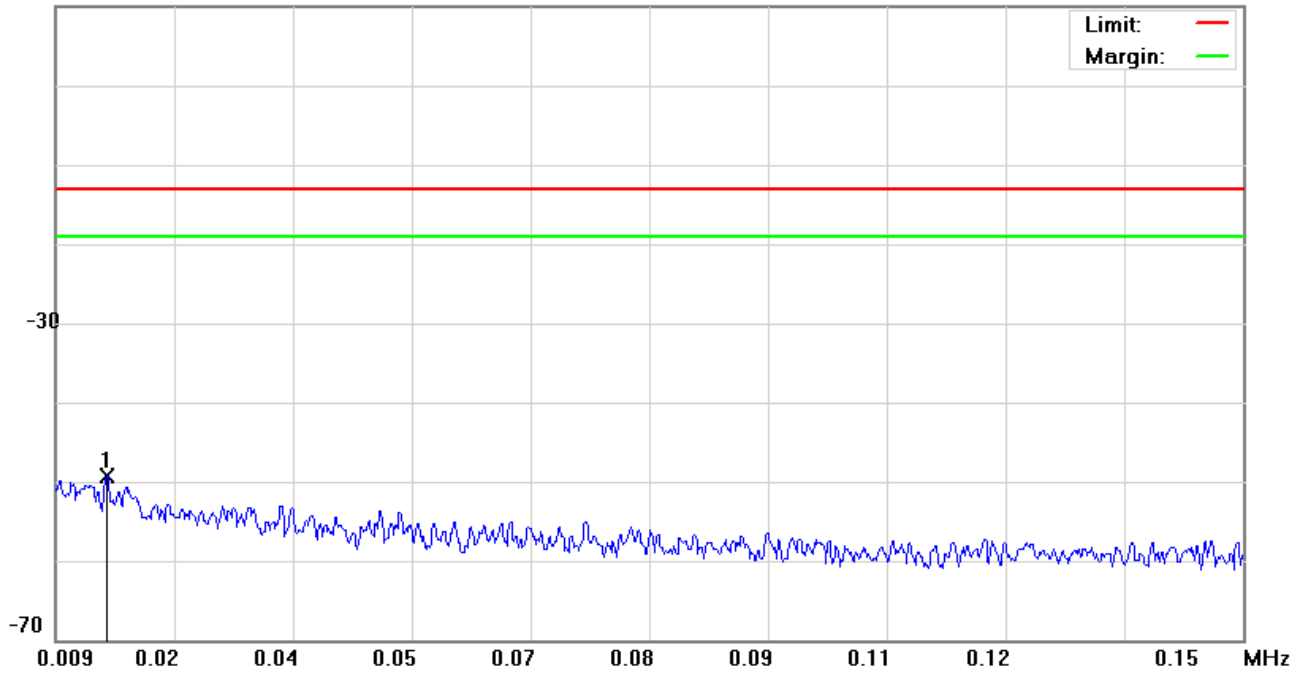

Site: site #1

Polarization: *Conducted po*

Temperature: 26 °C

Limit: FCC Part 22 conducted(9k-12.75G)

Power: DC 3.8V

Humidity: 55 %

EUT: GE910-QUAD V3

Distance:

RBW: 1 KHz VBW: 3 KHz

M/N: GE910-QUAD V3

Mode: GSM 850

Note:

No.	Mk.	Freq. MHz	Reading Level dBm	Correct Factor dB	Measure- ment dBm	Limit dBm	Over dB	Antenna Height cm	Table Degree degree	Comment
1	*	0.0151	-79.94	30.55	-49.39	-13.00	-36.39	peak		

*:Maximum data x:Over limit !:over margin

File :GE910-QUAD V3(CH251)

Data :#2

Date: 2013-7-11

Time: 下午 02:54:59

20.0 dBm

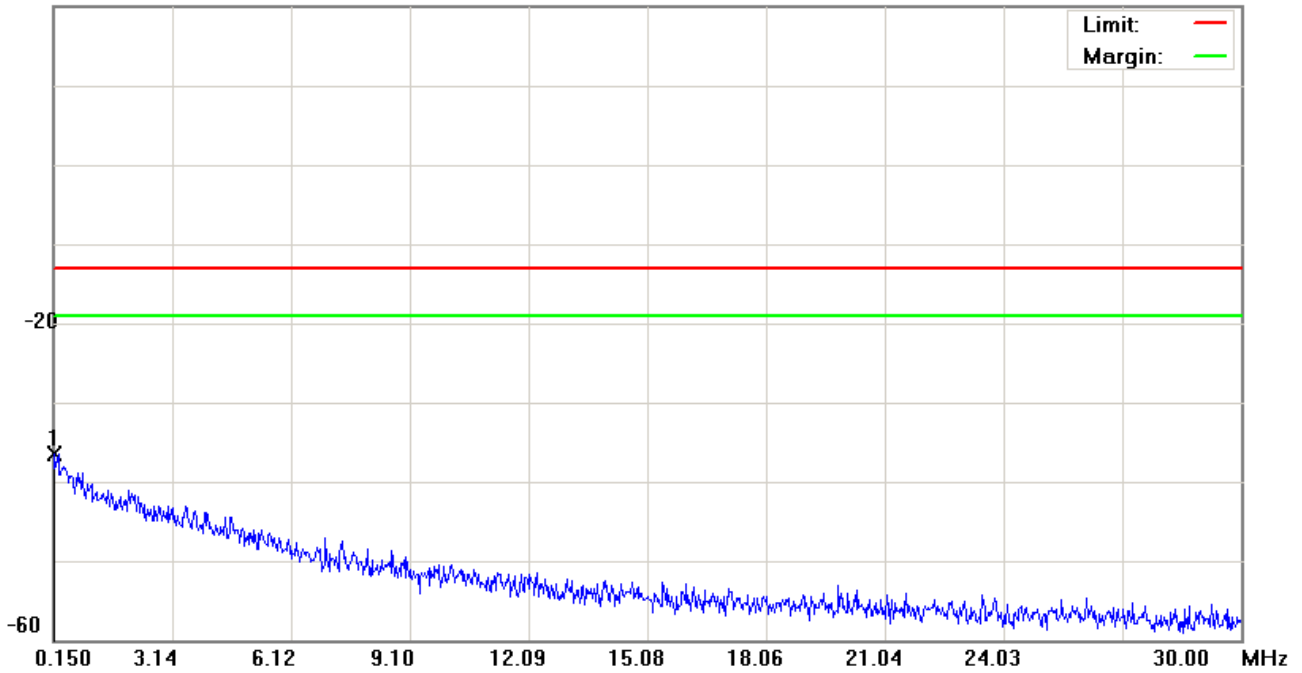

Site: site #1

Polarization: *Conducted po*

Temperature: 26 °C

Limit: FCC Part 22 conducted(9k-12.75G)

Power: DC 3.8V

Humidity: 55 %

EUT: GE910-QUAD V3

Distance:

RBW: 10 KHz VBW: 30 KHz

M/N: GE910-QUAD V3

Mode: GSM 850

Note:

No.	Mk.	Freq. MHz	Reading Level dBm	Correct Factor dB	Measure- ment dBm	Limit dBm	Over dB	Antenna Height cm	Table Degree degree	Comment
1	*	0.1798	-67.19	30.75	-36.44	-13.00	-23.44	peak		

*:Maximum data x:Over limit !:over margin

File :GE910-QUAD V3(CH512)

Data :#4

Date: 2013-7-11

Time: 下午 01:55:47

20.0 dBm

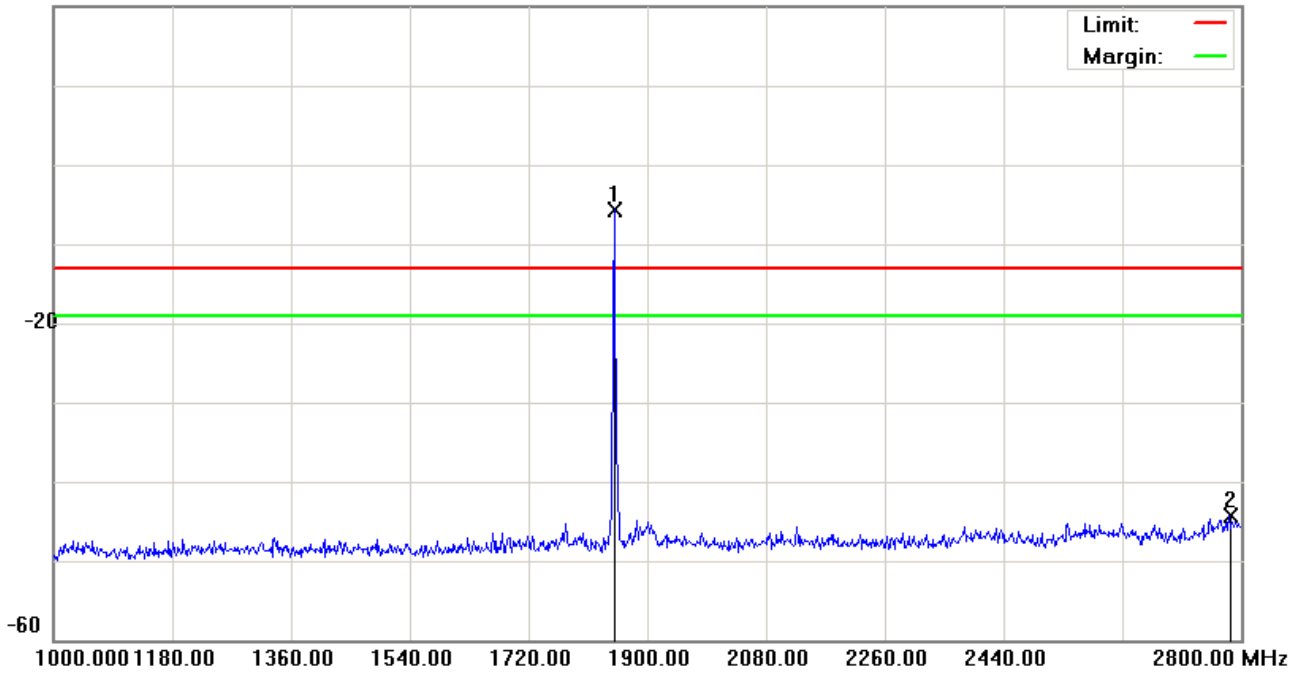

Site: site #1

Polarization: *Conducted po*

Temperature: 26 °C

Limit: FCC Part 24 conducted(9k-26.5G)

Power: DC 3.8V

Humidity: 55 %

EUT: GE910-QUAD V3

Distance:

RBW: 1000 KHz VBW: 3000 KHz

M/N: GE910-QUAD V3

Mode: GSM 1900

Note:

No.	Mk.	Freq. MHz	Reading Level dBm	Correct Factor dB	Measure- ment dBm	Limit dBm	Over dB	Antenna Height cm	Table Degree degree	Comment
1	*	1850.500	-10.05	4.26	-5.79	-13.00	7.21	peak		Tx
2		2782.900	-50.12	5.88	-44.24	-13.00	-31.24	peak		

*:Maximum data x:Over limit !:over margin

File :GE910-QUAD V3(CH512)

Data :#6

Date: 2013/7/11

Time: 下午 03:23:28

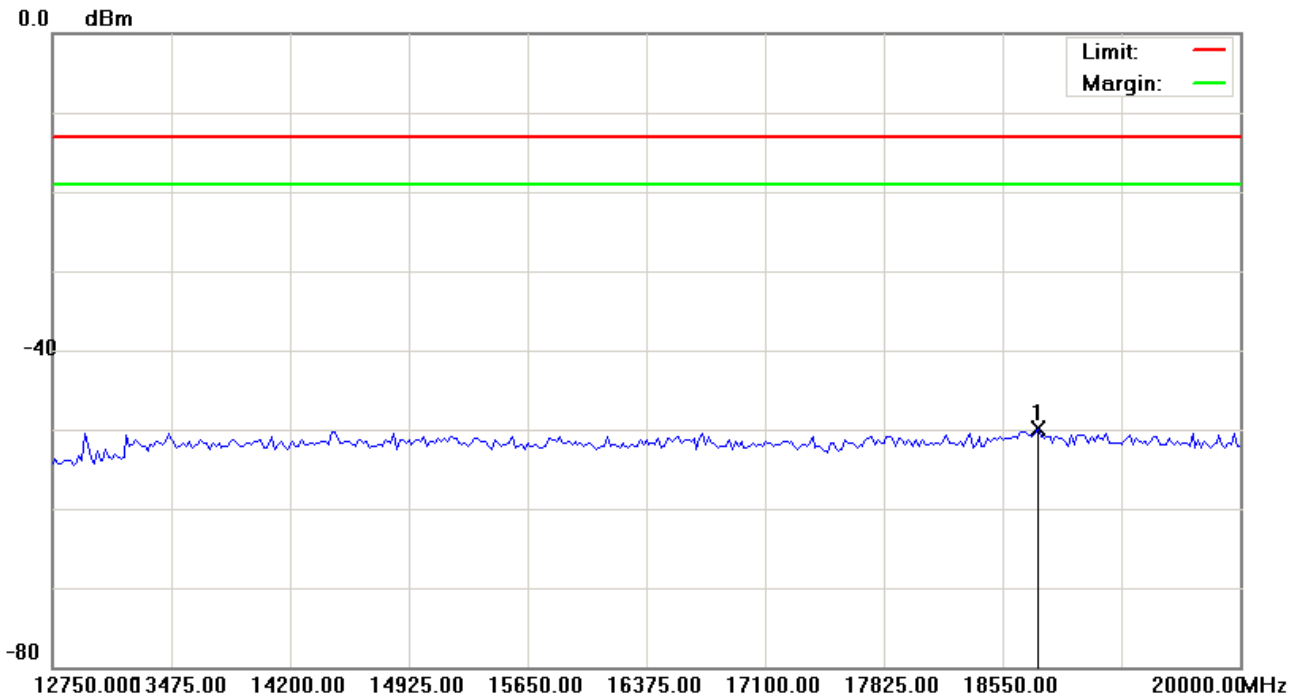

Site: site #1

Limit: FCC Part 24 conducted(9k-26.5G)

EUT: GE910-QUAD V3

M/N: GE910-QUAD V3

Mode: GSM 1900

Note:

Polarization: *Conducted po*

Power: DC 3.8V

Distance:

Temperature: 26 °C

Humidity: 55 %

RBW: 1000 KHz VBW: 3000 KHz

No.	Mk.	Freq. MHz	Reading Level dBm	Correct Factor dB	Measure- ment dBm	Limit dBm	Over dB	Detector	Antenna Height cm	Table Degree degree	Comment
1	*	18767.500	-57.08	7.09	-49.99	-13.00	-36.99	peak			

*:Maximum data x:Over limit !:over margin

File :GE910-QUAD V3(CH661)

Data :#1

Date: 2013-7-11

Time: 下午 01:47:35

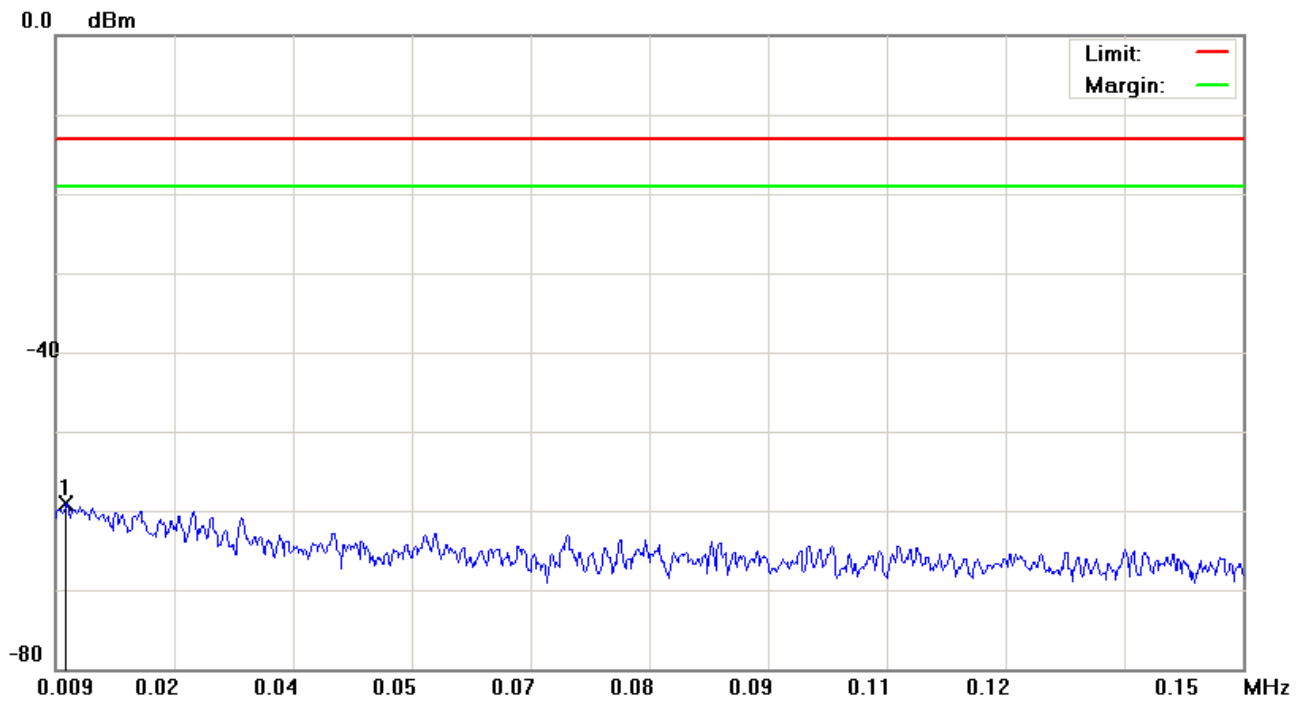

Site: site #1	Polarization: <i>Conducted po</i>	Temperature: 26 °C
Limit: FCC Part 24 conducted(9k-26.5G)	Power: DC 3.8V	Humidity: 55 %
EUT: GE910-QUAD V3	Distance:	RBW: 1 KHz VBW: 3 KHz
M/N: GE910-QUAD V3		
Mode: GSM 1900		
Note:		

No.	Mk.	Freq. MHz	Reading Level dBm	Correct Factor dB	Measure- ment dBm	Limit dBm	Over dB	Antenna Height cm	Table Degree degree	Comment
1	*	0.0103	-70.52	11.34	-59.18	-13.00	-46.18	peak		

*:Maximum data x:Over limit !:over margin

File :GE910-QUAD V3(CH661)

Data :#2

Date: 2013-7-11

Time: 下午 01:47:59

0.0 dBm

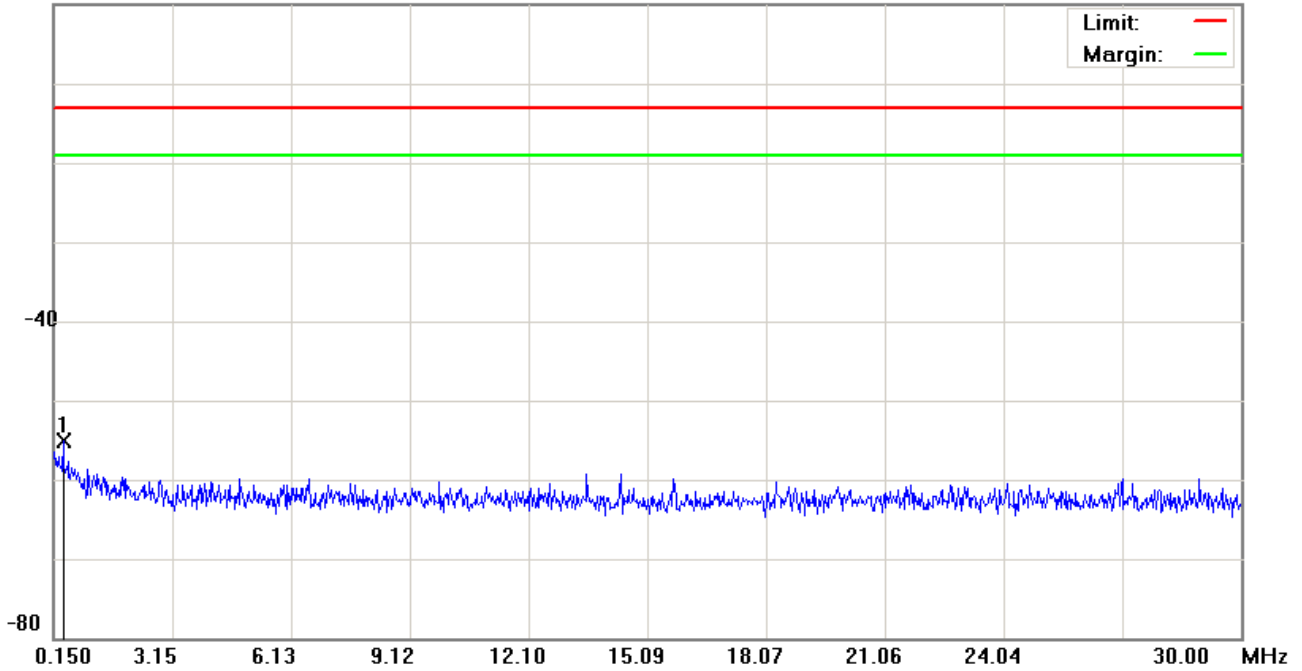

Site: site #1

Polarization: *Conducted po*

Temperature: 26 °C

Limit: FCC Part 24 conducted(9k-26.5G)

Power: DC 3.8V

Humidity: 55 %

EUT: GE910-QUAD V3

Distance:

RBW: 10 KHz VBW: 30 KHz

M/N: GE910-QUAD V3

Mode: GSM 1900

Note:

No.	Mk.	Freq. MHz	Reading Level dBm	Correct Factor dB	Measure- ment dBm	Limit dBm	Over dB	Antenna Height cm	Table Degree degree	Comment
1	*	0.4037	-67.91	12.82	-55.09	-13.00	-42.09	peak		

*:Maximum data x:Over limit !:over margin

File :GE910-QUAD V3(CH661)

Data :#3

Date: 2013-7-11

Time: 下午 01:48:23

0.0 dBm

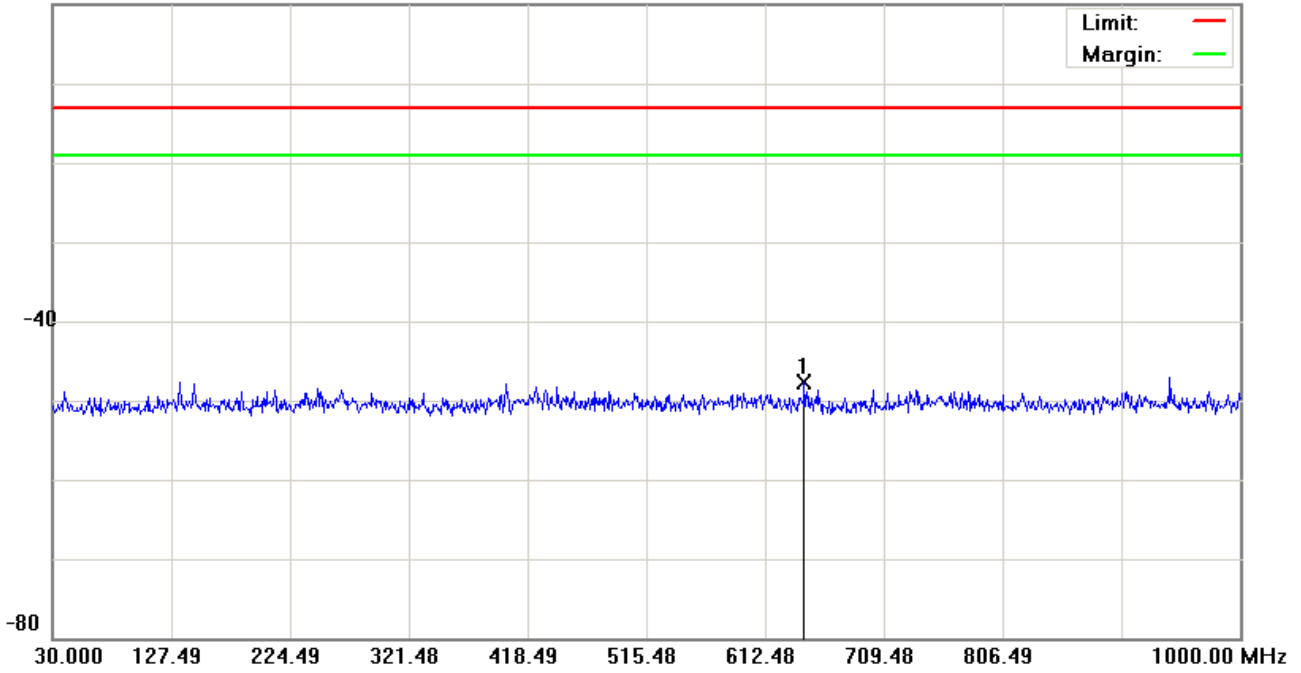

Site: site #1	Polarization: <i>Conducted po</i>	Temperature: 26 °C
Limit: FCC Part 24 conducted(9k-26.5G)	Power: DC 3.8V	Humidity: 55 %
EUT: GE910-QUAD V3	Distance:	RBW: 100 KHz VBW: 300 KHz
M/N: GE910-QUAD V3		
Mode: GSM 1900		
Note:		

No.	Mk.	Freq.	Reading Level	Correct Factor	Measurement	Limit	Over	Antenna Height	Table Degree	
		MHz	dBm	dB	dBm	dBm	dB	cm	degree	Comment
1	*	644.0100	-60.78	13.10	-47.68	-13.00	-34.68			peak

*:Maximum data x:Over limit !:over margin

File :GE910-QUAD V3(CH661)

Data :#5

Date: 2013/7/11

Time: 下午 03:24:00

0.0 dBm

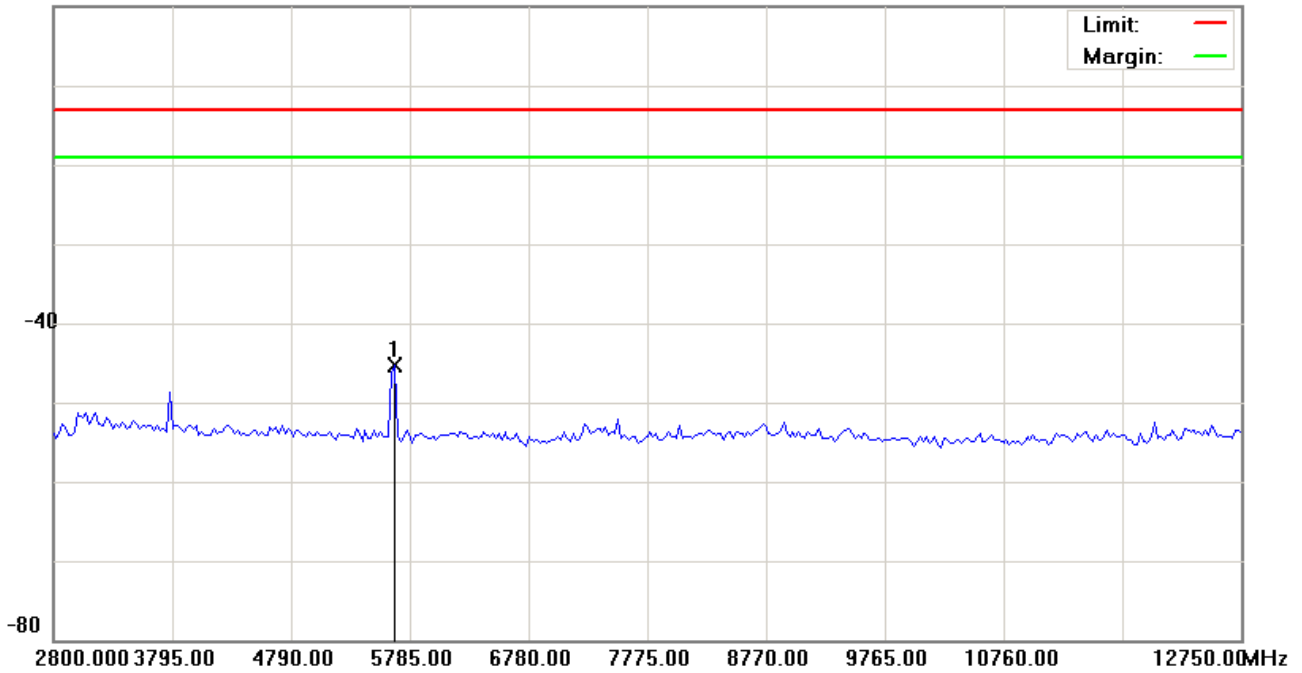

Site: site #1

Polarization: *Conducted po*

Temperature: 26 °C

Limit: FCC Part 24 conducted(9k-26.5G)

Power: DC 3.8V

Humidity: 55 %

EUT: GE910-QUAD V3

Distance:

RBW: 1000 KHz VBW: 3000 KHz

M/N: GE910-QUAD V3

Mode: GSM 1900

Note:

No.	Mk.	Freq.	Reading Level	Correct Factor	Measurement	Limit	Over	Antenna Height	Table Degree	
		MHz	dBm	dB	dBm	dBm	dB	cm	degree	Comment
1	*	5660.625	-50.20	4.84	-45.36	-13.00	-32.36			peak

*:Maximum data x:Over limit !:over margin

File :GE910-QUAD V3(CH810)

Data :#4

Date: 2013-7-11

Time: 下午 02:00:57

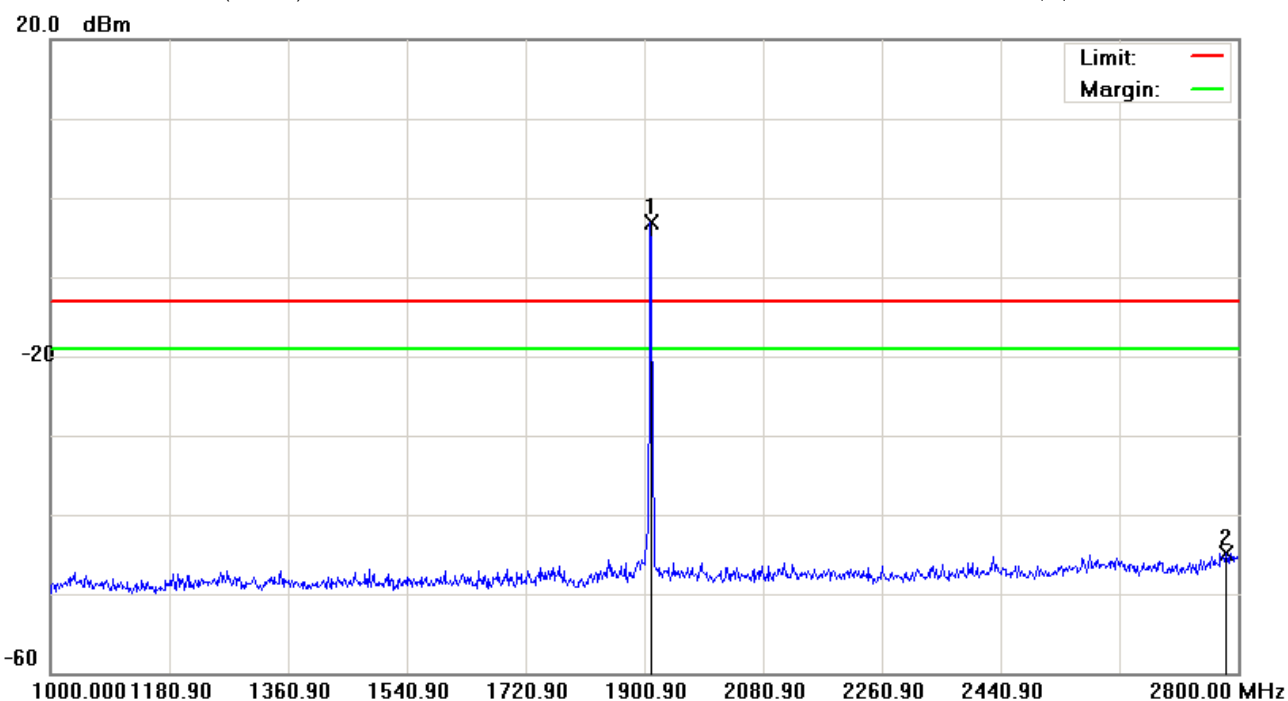

Site: site #1 Polarization: *Conducted po* Temperature: 26 °C
 Limit: FCC Part 24 conducted(9k-26.5G) Power: DC 3.8V Humidity: 55 %
 EUT: GE910-QUAD V3 Distance: RBW: 1000 KHz VBW: 3000 KHz
 M/N: GE910-QUAD V3
 Mode: GSM 1900
 Note:

No.	Mk.	Freq. MHz	Reading Level dBm	Correct Factor dB	Measure- ment dBm	Limit dBm	Over dB	Antenna Height cm	Table Degree degree	Comment
1	*	1909.900	-8.77	5.71	-3.06	-13.00	9.94	peak		Tx
2		2782.000	-50.87	5.88	-44.99	-13.00	-31.99	peak		

*:Maximum data x:Over limit !:over margin

File :GE910-QUAD V3(CH810)

Data :#5

Date: 2013/7/11

Time: 下午 03:24:55

0.0 dBm

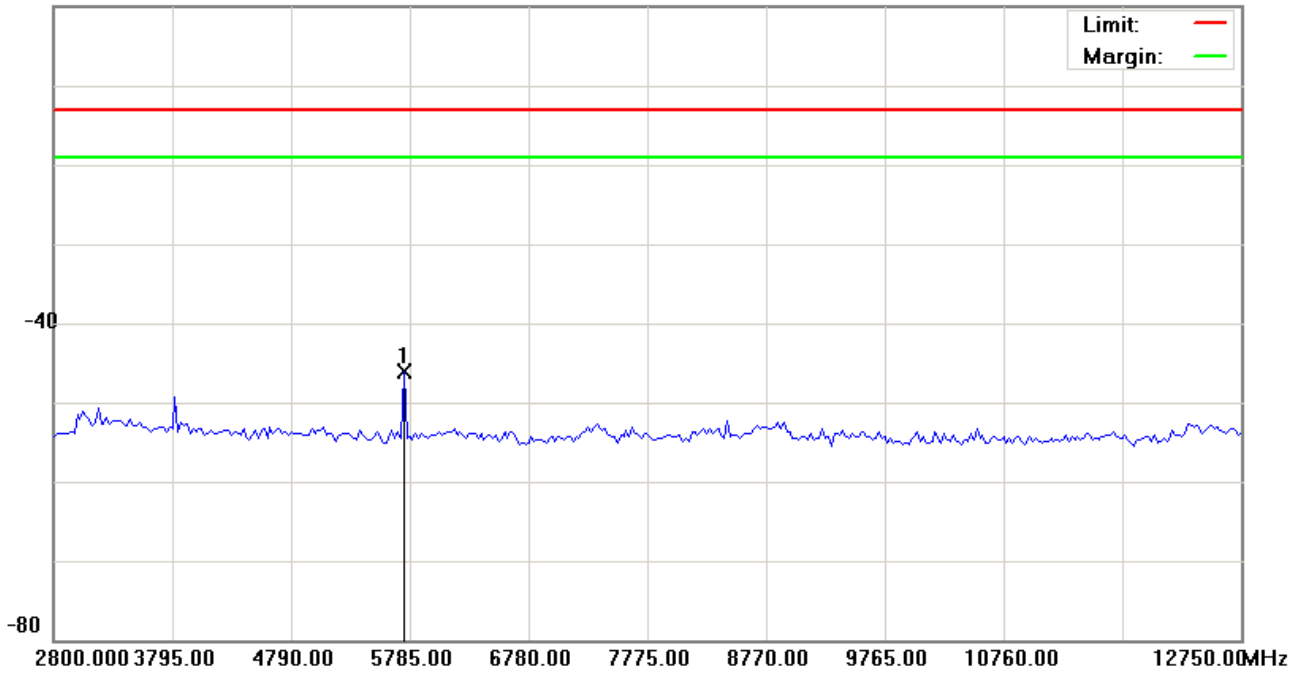

Site: site #1

Polarization: *Conducted po*

Temperature: 26 °C

Limit: FCC Part 24 conducted(9k-26.5G)

Power: DC 3.8V

Humidity: 55 %

EUT: GE910-QUAD V3

Distance:

RBW: 1000 KHz VBW: 3000 KHz

M/N: GE910-QUAD V3

Mode: GSM 1900

Note:

No.	Mk.	Freq.	Reading Level	Correct Factor	Measurement	Limit	Over	Antenna Height	Table Degree		
		MHz	dBm	dB	dBm	dBm	dB	Detector	cm	degree	Comment
1	*	5735.250	-51.04	4.89	-46.15	-13.00	-33.15	peak			

*:Maximum data x:Over limit !:over margin

7 Field Strength of Spurious Radiation Test

7.1. Limit

The power of any emission outside of the authorized operating frequency ranges must be attenuated below the transmitting power (P) by a factor of at least $43 + 10\log(P)$ dB.

It is measured by means of a calibrated spectrum analyzer and scanned from 30 MHz up to a frequency including its 10th harmonic.

7.2. Test Instruments

3 Meter Chamber					
Equipment	Manufacturer	Model Number	Serial Number	Cal. Date	Remark
RF Pre-selector	Agilent	N9039A	MY46520256	01/21/2013	(2)
Spectrum Analyzer	Agilent	E4446A	MY46180578	01/21/2013	(1)
Pre Amplifier	Agilent	8449B	3008A02237	02/21/2013	(1)
Pre Amplifier	Agilent	8447D	2944A10961	02/21/2013	(1)
Broadband Antenna (30MHz~1GHz)	SCHWARZBECK MESS-ELEKTRONIK	VULB9163	9163-270	07/01/2013	(1)
Horn Antenna (1~18GHz)	SCHWARZBECK MESS-ELEKTRONIK	BBHA9120D	9120D-550	06/10/2013	(1)
Horn Antenna (18~40GHz)	SCHWARZBECK MESS-ELEKTRONIK	BBHA9170	9170-320	06/13/2013	(1)
Test Site	ATL	TE01	888001	08/28/2012	(1)

Remark: ⁽¹⁾ Calibration period 1 year. ⁽²⁾ Calibration period 2 years.

Note: N.C.R. = No Calibration Request.

7.3. Setup

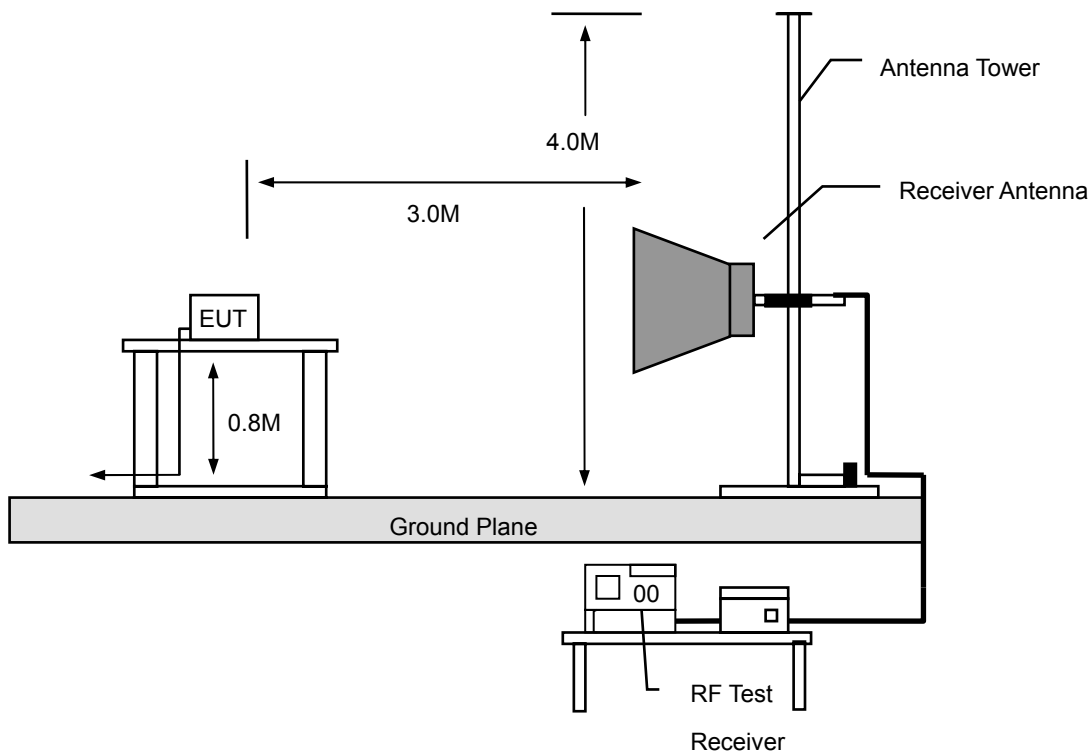

7.4. Test Procedure

Final radiation measurements were made on a three-meter, Semi Anechoic Chamber. The EUT system was placed on a nonconductive turntable which is 0.8 meters height, top surface 1.0 x 1.5 meter. The spectrum was examined from 250 MHz to 2.5 GHz in order to cover the whole spectrum below 10th harmonic which could generate from the EUT. During the test, EUT was set to transmit continuously & Measurements spectrum range from 30 MHz to 26.5 GHz is investigated.

For measurements below 1 GHz the resolution bandwidth is set to 100 kHz for peak detection measurements or 120 kHz for quasi-peak detection measurements. Peak detection is used unless otherwise noted as quasi-peak.

For measurements above 1 GHz the resolution bandwidth is set to 1 MHz, and then the video bandwidth is set to 1 MHz for peak measurements and 10 Hz for average measurements.

A nonconductive material surrounded the EUT to supporting the EUT for standing on three orthogonal planes. At each condition, the EUT was rotated 360 degrees, and the antenna was raised and lowered from one to four meters to find the maximum emission levels. Measurements were taken using both horizontal and vertical antenna polarization.

SCHWARZBECK MESS-ELEKTRONIK Biconilog Antenna (mode VULB9163) at 3 Meter and the SCHWARZBECK Double Ridged Guide Antenna (model BBHA9120D&9170) was used in frequencies 1 – 26.5 GHz at a distance of 1 meter. All test results were extrapolated to equivalent signal at 3 meters utilizing an inverse linear distance extrapolation Factor (20dB/decade).

For testing above 1GHz, the emission level of the EUT in peak mode was 20dB lower than average limit (that means the emission level in peak mode also complies with the limit in average mode), then testing will be stopped and peak values of EUT will be reported, otherwise, the emissions will be measured in average mode again and reported.

Appropriate preamplifiers were used for improving sensitivity and precautions were taken to avoid overloading or desensitizing the spectrum analyzer. No post – detector video filters were used in the test.

The spectrum analyzer's 6 dB bandwidth was set to 1 MHz, and the analyzer was operated in the peak detection mode, for frequencies both below and up 1 GHz. The average levels were obtained by subtracting the duty cycle correction factor from the peak readings.

The following procedures were used to convert the emission levels measured in decibels referenced to 1 microvolt (dBuV) into field intensity in micro volts pre meter (uV/m).

The actual field intensity in decibels referenced to 1 microvolt in to field intensity in micro volts per meter (dBuV/m).

The actual field intensity in decibels referenced to 1 microvolt per meter (dBuV/m) is determined by algebraically adding the measured reading in dBuV, the antenna factor (dB), and cable loss (dB) and Subtracting the gain of preamplifier (dB) is auto calculate in spectrum analyzer.

(1) $\text{Amplitude (dBuV/m)} = \text{FI (dBuV)} + \text{AF (dBuV)} + \text{CL (dBuV)} - \text{Gain (dB)}$

FI= Reading of the field intensity.

AF= Antenna factor.

CL= Cable loss.

P.S Amplitude is auto calculate in spectrum analyzer.

(2) $\text{Actual Amplitude (dBuV/m)} = \text{Amplitude (dBuV)} - \text{Dis(dB)}$

The FCC specified emission limits were calculated according the EUT operating frequency and by following linear interpolation equations:

(a) For fundamental frequency : $\text{Transmitter Output} < +30\text{dBm}$

(b) For spurious frequency : $\text{Spurious emission limits} = \text{fundamental emission limit} / 10$

7.5. Uncertainty

The measurement uncertainty is defined as for Field Strength of Spurious Radiation measurement is ± 3.072 dB.

7.6. Test Result

Standard:	FCC Part 22	Test Distance:	3m
Test item:	Radiated Emission	Power:	DC 3.8V
Model Number:	GE910-QUAD V3	Temp.(°C)/Hum.(%RH):	26(°C)/60%RH
Mode:	1	Date:	07/11/2013
Frequency:	824.2 MHz	Test By:	Fly Lu

Frequency (MHz)	Reading (dBm)	Correct Factor (dB)	Result (dBm)	Limit (dBm)	Margin (dB)	Remark	Ant.Polar. H / V
200.0000	-71.56	2.95	-68.61	-13.00	-55.61	peak	H
260.0000	-65.93	-4.34	-70.27	-13.00	-57.27	peak	H
390.0000	-79.14	1.65	-77.49	-13.00	-64.49	peak	H
564.5000	-75.86	7.77	-68.09	-13.00	-55.09	peak	H
688.0000	-79.79	6.99	-72.80	-13.00	-59.80	peak	H
776.5000	-80.57	9.99	-70.58	-13.00	-57.58	peak	H
2896.000	-72.16	17.47	-54.69	-13.00	-41.69	peak	H
4660.000	-72.56	21.94	-50.62	-13.00	-37.62	peak	H
6916.000	-74.56	32.27	-42.29	-13.00	-29.29	peak	H
156.0000	-73.17	10.76	-62.41	-13.00	-49.41	peak	V
200.0000	-80.74	10.15	-70.59	-13.00	-57.59	peak	V
390.0000	-70.35	1.48	-68.87	-13.00	-55.87	peak	V
430.0000	-71.22	1.40	-69.82	-13.00	-56.82	peak	V
612.5000	-79.47	8.36	-71.11	-13.00	-58.11	peak	V
720.0000	-78.04	10.86	-67.18	-13.00	-54.18	peak	V
2992.000	-70.60	20.17	-50.43	-13.00	-37.43	peak	V
4660.000	-72.88	26.49	-46.39	-13.00	-33.39	peak	V
6988.000	-72.00	30.54	-41.46	-13.00	-28.46	peak	V

Standard:	FCC Part 22	Test Distance:	3m
Test item:	Radiated Emission	Power:	DC 3.8V
Model Number:	GE910-QUAD V3	Temp.(°C)/Hum.(%RH):	26(°C)/60%RH
Mode:	1	Date:	07/11/2013
Frequency:	836.6 MHz	Test By:	Fly Lu

Frequency (MHz)	Reading (dBm)	Correct Factor (dB)	Result (dBm)	Limit (dBm)	Margin (dB)	Remark	Ant.Polar. H / V
200.0000	-72.33	2.95	-69.38	-13.00	-56.38	peak	H
260.0000	-65.87	-4.34	-70.21	-13.00	-57.21	peak	H
400.0000	-78.39	2.55	-75.84	-13.00	-62.84	peak	H
564.0000	-74.66	7.78	-66.88	-13.00	-53.88	peak	H
630.0000	-80.02	7.27	-72.75	-13.00	-59.75	peak	H
770.0000	-80.46	9.64	-70.82	-13.00	-57.82	peak	H
3004.000	-71.08	17.74	-53.34	-13.00	-40.34	peak	H
4708.000	-71.30	22.19	-49.11	-13.00	-36.11	peak	H
6880.000	-73.21	32.12	-41.09	-13.00	-28.09	peak	H
129.0000	-80.62	13.37	-67.25	-13.00	-54.25	peak	V
202.0000	-80.69	9.91	-70.78	-13.00	-57.78	peak	V
390.0000	-73.24	1.48	-71.76	-13.00	-58.76	peak	V
430.0000	-70.68	1.40	-69.28	-13.00	-56.28	peak	V
596.5000	-81.35	7.19	-74.16	-13.00	-61.16	peak	V
720.0000	-78.53	10.86	-67.67	-13.00	-54.67	peak	V
2980.000	-72.45	20.08	-52.37	-13.00	-39.37	peak	V
4732.000	-73.65	26.62	-47.03	-13.00	-34.03	peak	V
7060.000	-72.77	30.63	-42.14	-13.00	-29.14	peak	V

Standard:	FCC Part 22	Test Distance:	3m
Test item:	Radiated Emission	Power:	DC 3.8V
Model Number:	GE910-QUAD V3	Temp.(°C)/Hum.(%RH):	26(°C)/60%RH
Mode:	1	Date:	07/11/2013
Frequency:	848.8 MHz	Test By:	Fly Lu

Frequency (MHz)	Reading (dBm)	Correct Factor (dB)	Result (dBm)	Limit (dBm)	Margin (dB)	Remark	Ant.Polar. H / V
200.0000	-71.37	2.95	-68.42	-13.00	-55.42	peak	H
260.0000	-65.79	-4.34	-70.13	-13.00	-57.13	peak	H
400.0000	-79.66	2.55	-77.11	-13.00	-64.11	peak	H
525.5000	-79.90	7.81	-72.09	-13.00	-59.09	peak	H
590.0000	-75.96	7.77	-68.19	-13.00	-55.19	peak	H
724.5000	-79.12	7.65	-71.47	-13.00	-58.47	peak	H
3196.000	-69.27	18.27	-51.00	-13.00	-38.00	peak	H
4708.000	-73.43	22.19	-51.24	-13.00	-38.24	peak	H
6724.000	-73.84	31.45	-42.39	-13.00	-29.39	peak	H
156.0000	-72.03	10.76	-61.27	-13.00	-48.27	peak	V
200.0000	-79.49	10.15	-69.34	-13.00	-56.34	peak	V
390.0000	-71.87	1.48	-70.39	-13.00	-57.39	peak	V
430.0000	-71.46	1.40	-70.06	-13.00	-57.06	peak	V
605.0000	-80.60	7.81	-72.79	-13.00	-59.79	peak	V
708.0000	-79.83	10.46	-69.37	-13.00	-56.37	peak	V
3040.000	-70.74	20.46	-50.28	-13.00	-37.28	peak	V
4660.000	-74.11	26.49	-47.62	-13.00	-34.62	peak	V
6928.000	-72.42	30.37	-42.05	-13.00	-29.05	peak	V

Standard:	FCC Part 22	Test Distance:	3m
Test item:	Radiated Emission	Power:	DC 3.8V
Model Number:	GE910-QUAD V3	Temp.(°C)/Hum.(%RH):	26(°C)/60%RH
Mode:	2	Date:	07/11/2013
Frequency:	1850.2 MHz	Test By:	Fly Lu

Frequency (MHz)	Reading (dBm)	Correct Factor (dB)	Result (dBm)	Limit (dBm)	Margin (dB)	Remark	Ant.Polar. H / V
200.0000	-73.79	2.95	-70.84	-13.00	-57.84	peak	H
234.0000	-67.34	-1.38	-68.72	-13.00	-55.72	peak	H
390.0000	-77.72	1.65	-76.07	-13.00	-63.07	peak	H
533.5000	-80.21	8.05	-72.16	-13.00	-59.16	peak	H
697.0000	-80.63	6.96	-73.67	-13.00	-60.67	peak	H
891.0000	-81.47	13.68	-67.79	-13.00	-54.79	peak	H
3328.000	-72.11	18.62	-53.49	-13.00	-40.49	peak	H
4708.000	-72.93	22.19	-50.74	-13.00	-37.74	peak	H
6916.000	-74.46	32.27	-42.19	-13.00	-29.19	peak	H
156.0000	-73.06	10.76	-62.30	-13.00	-49.30	peak	V
200.0000	-81.05	10.15	-70.90	-13.00	-57.90	peak	V
306.0000	-80.69	2.22	-78.47	-13.00	-65.47	peak	V
430.0000	-71.93	1.40	-70.53	-13.00	-57.53	peak	V
618.0000	-80.17	8.74	-71.43	-13.00	-58.43	peak	V
825.0000	-80.94	11.30	-69.64	-13.00	-56.64	peak	V
3028.000	-71.27	20.39	-50.88	-13.00	-37.88	peak	V
4636.000	-73.49	26.44	-47.05	-13.00	-34.05	peak	V
6892.000	-74.25	30.27	-43.98	-13.00	-30.98	peak	V

Standard:	FCC Part 22	Test Distance:	3m
Test item:	Radiated Emission	Power:	DC 3.8V
Model Number:	GE910-QUAD V3	Temp.(°C)/Hum.(%RH):	26(°C)/60%RH
Mode:	2	Date:	07/11/2013
Frequency:	1880.0 MHz	Test By:	Fly Lu

Frequency (MHz)	Reading (dBm)	Correct Factor (dB)	Result (dBm)	Limit (dBm)	Margin (dB)	Remark	Ant.Polar. H / V
200.0000	-74.66	2.95	-71.71	-13.00	-58.71	peak	H
234.0000	-68.48	-1.38	-69.86	-13.00	-56.86	peak	H
400.0000	-77.44	2.55	-74.89	-13.00	-61.89	peak	H
546.0000	-80.22	8.12	-72.10	-13.00	-59.10	peak	H
697.5000	-80.71	6.95	-73.76	-13.00	-60.76	peak	H
908.0000	-81.86	14.33	-67.53	-13.00	-54.53	peak	H
3052.000	-70.40	17.88	-52.52	-13.00	-39.52	peak	H
4684.000	-73.77	22.06	-51.71	-13.00	-38.71	peak	H
6916.000	-73.36	32.27	-41.09	-13.00	-28.09	peak	H
155.5000	-73.89	10.51	-63.38	-13.00	-50.38	peak	V
200.0000	-81.41	10.15	-71.26	-13.00	-58.26	peak	V
350.0000	-77.27	1.80	-75.47	-13.00	-62.47	peak	V
430.0000	-71.24	1.40	-69.84	-13.00	-56.84	peak	V
597.5000	-80.89	7.26	-73.63	-13.00	-60.63	peak	V
780.0000	-78.63	11.28	-67.35	-13.00	-54.35	peak	V
3028.000	-71.72	20.39	-51.33	-13.00	-38.33	peak	V
4672.000	-73.47	26.52	-46.95	-13.00	-33.95	peak	V
7108.000	-74.05	30.68	-43.37	-13.00	-30.37	peak	V

Standard:	FCC Part 22	Test Distance:	3m
Test item:	Radiated Emission	Power:	DC 3.8V
Model Number:	GE910-QUAD V3	Temp.(°C)/Hum.(%RH):	26(°C)/60%RH
Mode:	2	Date:	07/11/2013
Frequency:	1909.8 MHz	Test By:	Fly Lu

Frequency (MHz)	Reading (dBm)	Correct Factor (dB)	Result (dBm)	Limit (dBm)	Margin (dB)	Remark	Ant.Polar. H / V
234.0000	-68.33	-1.38	-69.71	-13.00	-56.71	peak	H
390.0000	-77.44	1.65	-75.79	-13.00	-62.79	peak	H
538.0000	-81.10	8.19	-72.91	-13.00	-59.91	peak	H
688.5000	-81.35	6.99	-74.36	-13.00	-61.36	peak	H
824.0000	-81.00	11.95	-69.05	-13.00	-56.05	peak	H
945.0000	-81.86	14.86	-67.00	-13.00	-54.00	peak	H
3088.000	-70.64	17.99	-52.65	-13.00	-39.65	peak	H
4672.000	-72.52	22.01	-50.51	-13.00	-37.51	peak	H
7060.000	-73.29	32.78	-40.51	-13.00	-27.51	peak	H
156.0000	-74.12	10.76	-63.36	-13.00	-50.36	peak	V
206.5000	-81.62	9.37	-72.25	-13.00	-59.25	peak	V
370.0000	-78.76	2.03	-76.73	-13.00	-63.73	peak	V
430.0000	-71.62	1.40	-70.22	-13.00	-57.22	peak	V
644.5000	-80.84	8.79	-72.05	-13.00	-59.05	peak	V
830.5000	-81.07	11.32	-69.75	-13.00	-56.75	peak	V
3100.000	-72.30	20.81	-51.49	-13.00	-38.49	peak	V
4684.000	-73.78	26.53	-47.25	-13.00	-34.25	peak	V
7132.000	-73.44	30.70	-42.74	-13.00	-29.74	peak	V

Standard:	RSS-Gen	Test Distance:	3m
Test item:	Radiated Emission	Power:	DC 3.8V
Model Number:	GE910-QUAD V3	Temp.(°C)/Hum.(%RH):	26(°C)/60%RH
Mode:	3	Date:	07/11/2013
		Test By:	Fly Lu

Frequency (MHz)	Reading (dBm)	Correct Factor (dB)	Result (dBm)	Limit (dBm)	Margin (dB)	Remark	Ant.Polar. H / V
2827.000	34.84	5.46	40.30	74.00	-33.70	peak	H
4521.000	34.02	10.93	44.95	74.00	-29.05	peak	H
6579.000	32.87	17.80	50.67	74.00	-23.33	peak	H
2897.000	37.06	5.64	42.70	74.00	-31.30	peak	V
4465.000	33.74	10.75	44.49	74.00	-29.51	peak	V
6502.000	32.89	17.42	50.31	74.00	-23.69	peak	V

8 Frequency Stability (Temperature & Voltage Variation) Test

8.1. Limit

The frequency stability shall be measured by variation of ambient temperature and variation of primary supply voltage to ensure that the fundamental emission stays within the authorized frequency block. The frequency stability of the transmitter shall be maintained within $\pm 0.00025\%$ ($\pm 2.5\text{ppm}$) of the center frequency.

8.2. Test Instruments

Equipment	Manufacturer	Model Number	Serial Number	Cal. Date	Remark
Universal Radio Communication Tester	R & S	CMU200	109369	08/07/2012	(2)
Temperature & Humidity Chamber	TAICHY	MHU-225LA	980729	08/07/2012	(1)
Test Site	ATL	TE05	TE05	N.C.R.	-----

Remark: ⁽¹⁾ Calibration period 1 year. ⁽²⁾ Calibration period 2 years.

Note: N.C.R. = No Calibration Request.

8.3. Setup

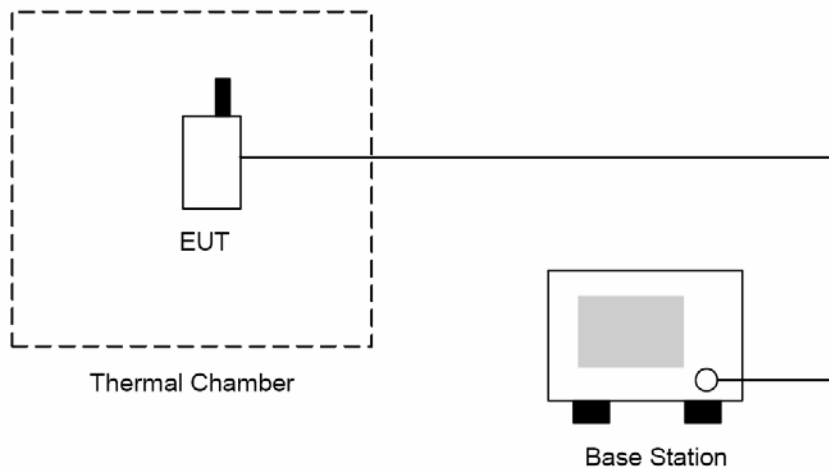

8.4. Test Procedure

The measurement is made according to FCC rules part 22 and 24:

1. The EUT and test equipment were set up as shown on the following section.
2. With all power removed, the temperature was decreased to -30°C and permitted to stabilize for three hours. Power was applied and the maximum change in frequency was note within one minute.
3. With power OFF, the temperature was raised in 10°C steps. The sample was permitted to stabilize at each step for at least one-half hour. Power was applied and the maximum frequency change was noted within one minute.
4. The EUT was placed in a temperature chamber at $25 \pm 5^{\circ}\text{C}$ and connected as the following section.
5. The power supply voltage to the EUT was varied from BEP to 115% of the nominal value measured at the input to the EUT.
6. The temperature tests were performed for the worst case.
7. Test data was recorded.

8.5. Uncertainty

The measurement uncertainty is defined as for Frequency Stability (Temperature Variation) measurement is $\pm 10\text{Hz}$.

8.6. Test Result

Model Number	GE910-QUAD V3					
Test Item	Frequency Stability (Temperature & Voltage Variation)					
Test Mode	Mode 1					
Date of Test	07/11/2013				Test Site	TE05
Level	Voltage [Vdc]	Temperature (°C)	Deviation (Hz)	Deviation (ppm)	Limit (ppm)	Result
Normal	3.80	-30	-26	-0.031	±2.5	Pass
Normal	3.80	-20	-20	-0.024	±2.5	Pass
Normal	3.80	-10	-10	-0.012	±2.5	Pass
Normal	3.80	0	-13	-0.016	±2.5	Pass
Normal	3.80	10	-14	-0.017	±2.5	Pass
Battery full point	4.20	20	-23	-0.027	±2.5	Pass
Normal	3.80	20	-13	-0.016	±2.5	Pass
Battery cut-off point	3.40	20	-17	-0.020	±2.5	Pass
Normal	3.80	30	-17	-0.020	±2.5	Pass
Normal	3.80	40	-22	-0.026	±2.5	Pass
Normal	3.80	50	-19	-0.023	±2.5	Pass

Model Number	GE910-QUAD V3					
Test Item	Frequency Stability (Temperature & Voltage Variation)					
Test Mode	Mode 2					
Date of Test	07/11/2013				Test Site	TE05
Level	Voltage [Vdc]	Temperature (°C)	Deviation (Hz)	Deviation (ppm)	Limit (ppm)	Result
Normal	3.80	-30	41	0.022	±2.5	Pass
Normal	3.80	-20	26	0.014	±2.5	Pass
Normal	3.80	-10	34	0.018	±2.5	Pass
Normal	3.80	0	32	0.017	±2.5	Pass
Normal	3.80	10	39	0.021	±2.5	Pass
Battery full point	4.20	20	36	0.019	±2.5	Pass
Normal	3.80	20	24	0.013	±2.5	Pass
Battery cut-off point	3.40	20	28	0.015	±2.5	Pass
Normal	3.80	30	27	0.014	±2.5	Pass
Normal	3.80	40	38	0.020	±2.5	Pass
Normal	3.80	50	20	0.011	±2.5	Pass