

GE910 Hardware User Guide

1v0300962 Rev.4 – 2012-06-25



APPLICABILITY TABLE

PRODUCT
GE910-QUAD



SPECIFICATIONS SUBJECT TO CHANGE WITHOUT NOTICE

Notice

While reasonable efforts have been made to assure the accuracy of this document, Telit assumes no liability resulting from any inaccuracies or omissions in this document, or from use of the information obtained herein. The information in this document has been carefully checked and is believed to be entirely reliable. However, no responsibility is assumed for inaccuracies or omissions. Telit reserves the right to make changes to any products described herein and reserves the right to revise this document and to make changes from time to time in content hereof with no obligation to notify any person of revisions or changes. Telit does not assume any liability arising out of the application or use of any product, software, or circuit described herein; neither does it convey license under its patent rights or the rights of others.

It is possible that this publication may contain references to, or information about Telit products (machines and programs), programming, or services that are not announced in your country. Such references or information must not be construed to mean that Telit intends to announce such Telit products, programming, or services in your country.

Copyrights

This instruction manual and the Telit products described in this instruction manual may be, include or describe copyrighted Telit material, such as computer programs stored in semiconductor memories or other media. Laws in the Italy and other countries preserve for Telit and its licensors certain exclusive rights for copyrighted material, including the exclusive right to copy, reproduce in any form, distribute and make derivative works of the copyrighted material. Accordingly, any copyrighted material of Telit and its licensors contained herein or in the Telit products described in this instruction manual may not be copied, reproduced, distributed, merged or modified in any manner without the express written permission of Telit. Furthermore, the purchase of Telit products shall not be deemed to grant either directly or by implication, estoppel, or otherwise, any license under the copyrights, patents or patent applications of Telit, as arises by operation of law in the sale of a product.

Computer Software Copyrights

The Telit and 3rd Party supplied Software (SW) products described in this instruction manual may include copyrighted Telit and other 3rd Party supplied computer programs stored in semiconductor memories or other media. Laws in the Italy and other countries preserve for Telit and other 3rd Party supplied SW certain exclusive rights for copyrighted computer programs, including the exclusive right to copy or reproduce in any form the copyrighted computer program. Accordingly, any copyrighted Telit or other 3rd Party supplied SW computer programs contained in the Telit products described in this instruction manual may not be copied (reverse engineered) or reproduced in any manner without the express written permission of Telit or the 3rd Party SW supplier. Furthermore, the purchase of Telit products shall not be deemed to grant either directly or by implication, estoppel, or otherwise, any license under the copyrights, patents or patent applications of Telit or other 3rd Party supplied SW, except for the normal non-exclusive, royalty free license to use that arises by operation of law in the sale of a product.



Usage and Disclosure Restrictions

License Agreements

The software described in this document is the property of Telit and its licensors. It is furnished by express license agreement only and may be used only in accordance with the terms of such an agreement.

Copyrighted Materials

Software and documentation are copyrighted materials. Making unauthorized copies is prohibited by law. No part of the software or documentation may be reproduced, transmitted, transcribed, stored in a retrieval system, or translated into any language or computer language, in any form or by any means, without prior written permission of Telit

High Risk Materials

Components, units, or third-party products used in the product described herein are NOT fault-tolerant and are NOT designed, manufactured, or intended for use as on-line control equipment in the following hazardous environments requiring fail-safe controls: the operation of Nuclear Facilities, Aircraft Navigation or Aircraft Communication Systems, Air Traffic Control, Life Support, or Weapons Systems (High Risk Activities"). Telit and its supplier(s) specifically disclaim any expressed or implied warranty of fitness for such High Risk Activities.

Trademarks

TELIT and the Stylized T Logo are registered in Trademark Office. All other product or service names are the property of their respective owners.

Copyright © Telit Communications S.p.A.



Contents

- 1. Introduction.....7**
 - 1.1. Scope.....7
 - 1.2. Audience7
 - 1.3. Contact Information, Support.....7
 - 1.4. Document Organization8
 - 1.5. Text Conventions9
 - 1.6. Related Documents9
- 2. Overview10**
- 3. GE910 module connections11**
 - 3.1. PIN-OUT.....11
 - 3.2. LGA PADS Layout.....16
- 4. Hardware Commands.....17**
 - 4.1. Turning ON the GE910.....17
 - 4.2. Turning OFF the GE91021
 - 4.3. HW Unconditional Shutdown on GE910.....23
 - 4.3.1. *Hardware Unconditional shutdown*23
- 5. Power Supply.....26**
 - 5.1. Power Supply Requirements26
 - 5.2. Power Consumption27
 - 5.3. General Design Rules.....28
 - 5.3.1. *Electrical Design Guidelines*.....28
 - 5.3.2. *Thermal Design Guidelines*.....31
 - 5.3.3. *Power Supply PCB layout Guidelines*32
- 6. Antenna.....33**
 - 6.1. GSM Antenna Requirements33
 - 6.2. GSM Antenna - PCB line Guidelines.....34
 - 6.3. PCB Guidelines in case of FCC certification35
 - 6.3.1. *Transmission line design*.....35
 - 6.3.2. *Transmission line measurements*.....36
 - 6.4. GSM Antenna - Installation Guidelines38
- 7. Logic level specifications39**
 - 7.1. Unconditional Shutdown.....40
- 8. Serial Ports41**
 - 8.1. MODEM SERIAL PORT41
 - 8.2. RS232 level translation43
- 9. USB Port45**
 - 9.1. USB 2.0 FS45
- 10. Audio Section Overview46**
 - 10.1. MIC connection.....47
 - 10.2. LINE-IN connection.....48



10.3.	EAR connection	49
10.4.	Electrical Characteristics	50
10.4.1.	Input Lines	50
10.4.2.	Output Lines	51
11.	General Purpose I/O	52
11.1.	GPIO Logic levels	53
11.2.	Using a GPIO Pad as INPUT	54
11.3.	Using a GPIO Pad as OUTPUT	54
11.4.	Indication of network service availability	55
11.5.	RTC Bypass out	56
11.6.	External SIM Holder Implementation	56
11.7.	ADC Converter	56
11.7.1.	Description	56
11.7.2.	Using ADC Converter	56
12.	Mounting the GE910 on your Board.....	57
12.1.	General	57
12.2.	Module finishing & dimensions	57
12.3.	Recommended foot print for the application	58
12.4.	Stencil	59
12.5.	PCB pad design	59
12.6.	Recommendations for PCB pad dimensions (mm):	59
12.7.	Solder paste	61
12.7.1.	GE910 Solder reflow	61
13.	Debug of the GE910 in production.....	63
14.	Packing system.....	64
14.1.	Packing on tray	64
14.2.	Moisture sensibility	66
15.	Conformity Assessment Issues.....	Error! Bookmark not defined.
16.	SAFETY RECOMMANDATIONS.....	67
17.	Document History	73



1. Introduction

1.1. Scope

The aim of this document is the description of some hardware solutions useful for developing a product with the Telit GE910 module.

1.2. Audience

This document is intended for Telit customers, who are integrators, about to implement their applications using our GE910 modules.

1.3. Contact Information, Support

For general contact, technical support, to report documentation errors and to order manuals, contact Telit's Technical Support Center (TTSC) at:

TS-EMEA@telit.com
TS-NORTHAMERICA@telit.com
TS-LATINAMERICA@telit.com
TS-APAC@telit.com

Alternatively, use:

<http://www.telit.com/en/products/technical-support-center/contact.php>

For detailed information about where you can buy the Telit modules or for recommendations on accessories and components visit:

<http://www.telit.com>

To register for product news and announcements or for product questions contact Telit's Technical Support Center (TTSC).

Our aim is to make this guide as helpful as possible. Keep us informed of your comments and suggestions for improvements.

Telit appreciates feedback from the users of our information.



1.4. Document Organization

This document contains the following chapters:

Chapter 1: “Introduction” provides a scope for this document, target audience, contact and support information, and text conventions.

Chapter 2: “Overview” provides an overview of the document.

Chapter 3: “GE910 Mechanical Dimensions”

Chapter 3: “GE910 Module Connections” deals with the pin out configuration and layout.

Chapter 4: “Hardware Commands” How to operate on the module via hardware.

Chapter 5: “Power supply” Power supply requirements and general design rules.

Chapter 6: “Antenna” The antenna connection and board layout design are the most important parts in the full product design.

Chapter 7: “Logic Level specifications” Specific values adopted in the implementation of logic levels for this module.

Chapter 8: “Serial ports” The serial port on the Telit GE910 is the core of the interface between the module and OEM hardware

Chapter 9: “Audio Section overview” Refers to the audio blocks of the Base Band Chip of the GE910 Telit Modules.

Chapter 10: “General Purpose I/O” How the general purpose I/O pads can be configured.

Chapter 11: “Mounting the GE910 on the application board” Recommendations and specifics on how to mount the module on the user’s board.



1.5. Text Conventions



Danger – This information MUST be followed or catastrophic equipment failure or bodily injury may occur.



Caution or Warning – Alerts the user to important points about integrating the module, if these points are not followed, the module and end user equipment may fail or malfunction.



Tip or Information – Provides advice and suggestions that may be useful when integrating the module.

All dates are in ISO 8601 format, i.e. YYYY-MM-DD.

1.6. Related Documents

- Telit's GSM/GPRS Family Software User Guide, 1vv0300784
- Audio settings application note , 80000NT10007a
- Digital Voice Interface Application Note, 80000NT10004a
- GE910 Product description,
- SIM Holder Design Guides, 80000NT10001a
- AT Commands Reference Guide, 80000ST10025a
- Telit EVK2 User Guide, 1vv0300704



2. Overview

The aim of this document is the description of some hardware solutions useful for developing a product with the Telit GE910 module.

In this document all the basic functions of a mobile phone will be taken into account; for each one of them a proper hardware solution will be suggested and eventually the wrong solutions and common errors to be avoided will be evidenced. Obviously this document cannot embrace the whole hardware solutions and products that may be designed. The wrong solutions to be avoided shall be considered as mandatory, while the suggested hardware configurations shall not be considered mandatory, instead the information given shall be used as a guide and a starting point for properly developing your product with the Telit GE910 module. For further hardware details that may not be explained in this document refer to the Telit GE910 Product Description document where all the hardware information is reported.



NOTICE:

(The integration of the GSM/GPRS **GE910** cellular module within user application shall be done according to the design rules described in this manual.)

The information presented in this document is believed to be accurate and reliable. However, no responsibility is assumed by Telit Communications S.p.A. for its use, nor any infringement of patents or other rights of third parties which may result from its use. No license is granted by implication or otherwise under any patent rights of Telit Communications S.p.A. other than for circuitry embodied in Telit products. This document is subject to change without notice.



3. GE910 module connections

3.1. PIN-OUT

PAD	Signal	I/O	Function	Type	COMMENT
USB HS 2.0 COMMUNICATION PORT					
B15	USB_D+	I/O	USB differential Data (+)		
C15	USB_D-	I/O	USB differential Data (-)		
Asynchronous UART - Prog. / Data + HW Flow Control					
N15	C103/TXD	I	Serial data input from DTE	CMOS 1.8V	
M15	C104/RXD	O	Serial data output to DTE	CMOS 1.8V	
M14	C108/DTR	I	Input for (DTR) from DTE	CMOS 1.8V	
L14	C105/RTS	I	Input for Request to send signal (RTS) from DTE	CMOS 1.8V	
P15	C106/CTS	O	Output for Clear to Send signal (CTS) to DTE	CMOS 1.8V	
N14	C109/DCD	O	Output for (DCD) to DTE	CMOS 1.8V	
P14	C107/DSR	O	Output for (DSR) to DTE	CMOS 1.8V	
R14	C125/RING	O	Output for Ring (RI) to DTE	CMOS 1.8V	
Asynchronous Auxiliary UART					
D15	TX_AUX	O	Auxiliary UART (TX Data to DTE)	CMOS 1.8V	
E15	RX_AUX	I	Auxiliary UART (RX Data from DTE)	CMOS 1.8V	
SIM card interface					
A6	SIMCLK	O	External SIM signal – Clock	1.8 / 3V	
A7	SIMRST	O	External SIM signal – Reset	1.8 / 3V	
A5	SIMIO	I/O	External SIM signal – Data I/O	1.8 / 3V	
A4	SIMIN	I	External SIM signal – Presence (active low)	CMOS 1.8	
A3	SIMVCC	-	External SIM signal – Power supply for the SIM	1.8 / 3V	
Analog Voice Interface					
B2	EAR+	AO	Ear signal output, phase +		
B3	EAR-	AO	Ear signal output, phase -		
B4	MIC+	AI	Microphone signal input; phase +		
B5	MIC-	AI	Microphone signal input; phase -		
Digital Voice Interface (DVI)					
B9	DVI_WA0	I/O	Digital Audio Interface (WA0)	CMOS 1.8V	
B6	DVI_RX	I/O	Digital Audio Interface (RX)	CMOS 1.8V	
B7	DVI_TX	I/O	Digital Audio Interface (TX)	CMOS 1.8V	
B8	DVI_CLK	I/O	Digital Audio Interface (CLK)	CMOS 1.8V	
DIGITAL IO					
C8	GPIO_01	I/O	GPIO_01 /STAT LED	CMOS 1.8V	Alternate Function STAT LED



C9	GPIO_02	I/O	GPIO_02	CMOS 1.8V	
C10	GPIO_03	I/O	GPIO_03	CMOS 1.8V	
C11	GPIO_04	I/O	GPIO_04	CMOS 1.8V	
B14	GPIO_05	I/O	GPIO_05	CMOS 1.8V	
C12	GPIO_06	I/O	GPIO_06	CMOS 1.8V	
C13	GPIO_07	I/O	GPIO_07	CMOS 1.8V	
K15	GPIO_08	I/O	GPIO_08	CMOS 1.8V	
L15	GPIO_09	I/O	GPIO_09	CMOS 1.8V	
G15	GPIO_10	I/O	GPIO_10	CMOS 1.8V	
ADC					
B1	ADC_IN1	AI	Analog to Digital converter input	A/D	Values 0 to 1.3V
RF SECTION					
K1	ANTENNA	I/O	GSM/GPRS Antenna (50 ohm)	RF	
MISCELLANEOUS FUNCTIONS					
R13	HW_SHUTDOWN*	I	HW Unconditional Shutdown	CMOS 1.8V	Active low
R12	ON_OFF*	I	Input command for power ON	CMOS 1.8V	Active low
C14	VRTC	I	VRTC Backup capacitor	RTC Power	Backup for the embedded RTC supply, don't connect to VBATT!
R11	VAUX/PWRMON	O	Supply Output for external accessories / Power ON Monitor	1.8V	
POWER SUPPLY					
M1	VBATT	-	Main power supply (Baseband)	Power	
M2	VBATT	-	Main power supply (Baseband)	Power	
N1	VBATT_PA	-	Main power supply (Radio PA)	Power	
N2	VBATT_PA	-	Main power supply (Radio PA)	Power	
P1	VBATT_PA	-	Main power supply (Radio PA)	Power	
P2	VBATT_PA	-	Main power supply (Radio PA)	Power	
E1	GND	-	Ground	Power	
G1	GND	-	Ground	Power	
H1	GND	-	Ground	Power	
J1	GND	-	Ground	Power	
L1	GND	-	Ground	Power	
A2	GND	-	Ground	Power	
E2	GND	-	Ground	Power	
F2	GND	-	Ground	Power	
G2	GND	-	Ground	Power	
H2	GND	-	Ground	Power	
J2	GND	-	Ground	Power	
K2	GND	-	Ground	Power	
L2	GND	-	Ground	Power	



GE910 Hardware User Guide
1v0300962 Rev.4 2012-06-25

R2	GND	-	Ground	Power	
M3	GND	-	Ground	Power	
N3	GND	-	Ground	Power	
P3	GND	-	Ground	Power	
R3	GND	-	Ground	Power	
M4	GND	-	Ground	Power	
N4	GND	-	Ground	Power	
P4	GND	-	Ground	Power	
R4	GND	-	Ground	Power	
N5	GND	-	Ground	Power	
P5	GND	-	Ground	Power	
R5	GND	-	Ground	Power	
N6	GND	-	Ground	Power	
P6	GND	-	Ground	Power	
R6	GND	-	Ground	Power	
P8	GND	-	Ground	Power	
R8	GND	-	Ground	Power	
P9	GND	-	Ground	Power	
P10	GND	-	Ground	Power	
R10	GND	-	Ground	Power	
M12	GND	-	Ground	Power	
B13	GND	-	Ground	Power	
P13	GND	-	Ground	Power	
E14	GND	-	Ground	Power	
RESERVED					
C1	RESERVED	-	RESERVED		
D1	RESERVED	-	RESERVED		
C2	RESERVED	-	RESERVED		
D2	RESERVED	-	RESERVED		
C3	RESERVED	-	RESERVED		
D3	RESERVED	-	RESERVED		
E3	RESERVED	-	RESERVED		
F3	RESERVED	-	RESERVED		
G3	RESERVED	-	RESERVED		
H3	RESERVED	-	RESERVED		
J3	RESERVED	-	RESERVED		
K3	RESERVED	-	RESERVED		
L3	RESERVED	-	RESERVED		
C4	RESERVED	-	RESERVED		
C5	RESERVED	-	RESERVED		
C6	RESERVED	-	RESERVED		
C7	RESERVED	-	RESERVED		



GE910 Hardware User Guide
1v0300962 Rev.4 2012-06-25

N7	RESERVED	-	RESERVED		
P7	RESERVED	-	RESERVED		
N8	RESERVED	-	RESERVED		
N9	RESERVED	-	RESERVED		
A10	RESERVED	-	RESERVED		
N10	RESERVED	-	RESERVED		
N11	RESERVED	-	RESERVED		
B12	RESERVED	-	RESERVED		
D12	RESERVED	-	RESERVED		
N12	RESERVED	-	RESERVED		
P12	RESERVED	-	RESERVED		
F14	RESERVED	-	RESERVED		
G14	RESERVED	-	RESERVED		
H14	RESERVED	-	RESERVED		
J14	RESERVED	-	RESERVED		
K14	RESERVED	-	RESERVED		
N13	RESERVED	-	RESERVED		
L13	RESERVED	-	RESERVED		
J13	RESERVED	-	RESERVED		
M13	RESERVED	-	RESERVED		
K13	RESERVED	-	RESERVED		
H13	RESERVED	-	RESERVED		
G13	RESERVED	-	RESERVED		
F13	RESERVED	-	RESERVED		
A11	RESERVED	-	RESERVED		
A12	RESERVED	-	RESERVED		
B11	RESERVED	-	RESERVED		
B10	RESERVED	-	RESERVED		
A9	RESERVED	-	RESERVED		
A8	RESERVED	-	RESERVED		
A13	RESERVED	-	RESERVED		
A14	RESERVED	-	RESERVED		
D13	RESERVED	-	RESERVED		
D14	RESERVED	-	RESERVED		
H15	RESERVED	-	RESERVED		
J15	RESERVED	-	RESERVED		
F1	RESERVED	-	RESERVED		
R9	RESERVED	-	RESERVED		
R7	RESERVED	-	RESERVED		
D4	RESERVED	-	RESERVED		
E13	RESERVED	-	RESERVED		



F15	RESERVED	-	RESERVED		
P11	RESERVED	-	RESERVED		



WARNING:

Reserved pins must not be connected.



NOTE:

If not used, almost all pins should be left disconnected. The only exceptions are the following pins:

PAD	signal
M1,M2,N1,N2,P1,P2	VBATT & VBATT_PA
E1,G1,H1,J1,L1,A2,E2,F2,G2,H2, J2,K2,L2,R2,M3,N3,P3,R3,M4, N4,P4,R4,N5,P5,R5,N6,P6,R6,P8, R8,P9,P10,R10,M12,B13,P13,E14	GND
R12	ON/OFF*
R13	HW_SHUTDOWN*
B15	USB_D+
C15	USB_D-
N15	C103/TXD
M15	C104/RXD
L14	C105/RTS
P15	C106/CTS
D15	TXD_AUX
E15	RXD_AUX



NOTE:

RTS pin should be connected to the GND (on the module side) if flow control is not used.

The above pins are also necessary to debug the application when the module is assembled on it.



3.2. LGA PADs Layout

TOP VIEW

	A	B	C	D	E	F	G	H	J	K	L	M	N	P	R
1		RES	RES	RES	GND	RES	GND	GND	GND	ANT	GND	VBATT	VBATT_PA	VBATT_PA	
2	GND	EAR+	RES	RES	GND	GND	GND	GND	GND	GND	GND	VBATT	VBATT_PA	VBATT_PA	GND
3	SIMVC C	EAR-	RES	RES	RES	RES	RES	RES	RES	RES	RES	GND	GND	GND	GND
4	SIMIN	MIC+	RES	RES								GND	GND	GND	GND
5	SIMIO	MIC-	RES										GND	GND	GND
6	SIMCLK	DVI_RX	RES										GND	GND	GND
7	SIMRST	DVI_TX	RES										RES	RES	RES
8	RES	DVI_CLK	GPIO_01										RES	GND	GND
9	RES	DVI_WA0	GPIO_02										RES	GND	RES
10	RES	RES	GPIO_03										RES	GND	GND
11	RES	RES	GPIO_04										RES	RES	VAUX_P WRMON
12	RES	RES	GPIO_06	RES								GND	RES	RES	ON_OFF*
13	RES	GND	GPIO_07	RES	VIOL_IV8	RES	RES	RES	RES	RES	RES	RES	RES	GND	HW_SHU TDOWN*
14	RES	GPIO_05	VRTC	RES	GND	RES	RES	RES	RES	RES	C105/RT S	C108/D T R	C109/D C D	C107/D S R	C125/R I N G
15		USB_D+	USB_D-	TX AUX	RX AUX	RES	GPIO_10	RES	RES	GPIO_08	GPIO_09	C104/R X D	C103/T X D	C106/C T S	



NOTE:

The pin defined as H4 has to be considered RESERVED and not connected on any pin in the application. The related area on the application has to be kept empty.



4. Hardware Commands

4.1. Turning ON the GE910

To turn on the GE910 the pad ON-OFF* must be tied low for at least 5 seconds and then released.

The maximum current that can be drained from the ON-OFF* pad is 0,2 mA.
A simple circuit to do it is:

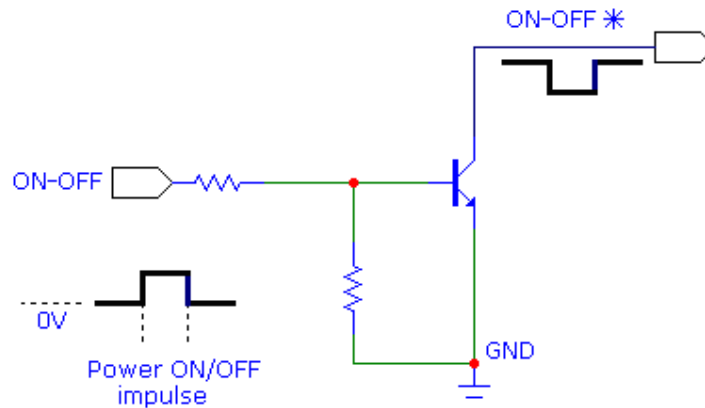

NOTE:

Don't use any pull up resistor on the ON* line, it is internally pulled up. Using pull up resistor may bring to latch up problems on the GE910 power regulator and improper power on/off of the module. The line ON* must be connected only in open collector configuration.



NOTE:

In this document all the lines that are inverted, hence have active low signals are labelled with a name that ends with "*" or with a bar over the name.



TIP:

To check if the device has powered on, the hardware line PWRMON should be monitored. The device is powered on when PWRMON goes high.



NOTE:

It is mandatory to avoid sending data to the serial ports during the first 200mS of the module start-up.



The flow chart showing the proper turn on procedure is displayed below:

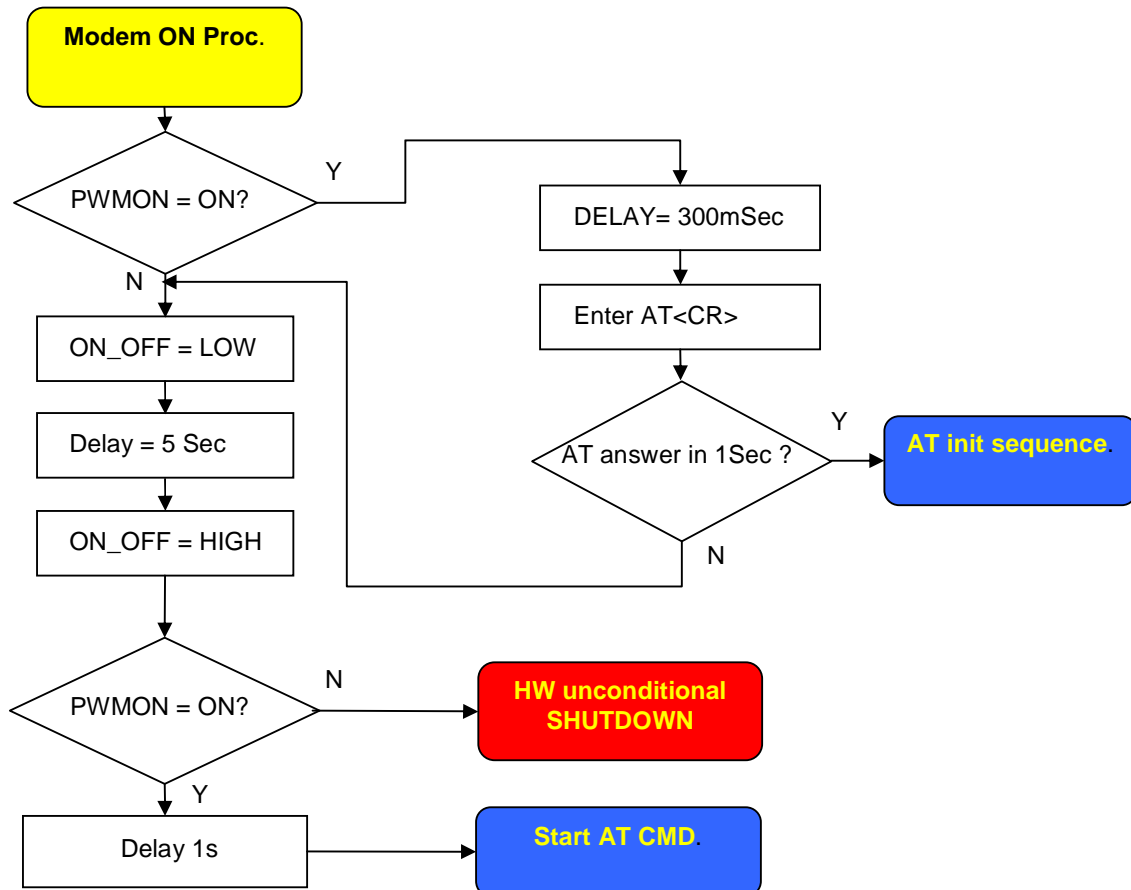

NOTE:

In order to avoid a back powering effect it is recommended to avoid having any HIGH logic level signal applied to the digital pins of the GE910 when the module is powered off or during an ON/OFF transition.



The Flow chart showing the AT commands managing procedure is displayed below:

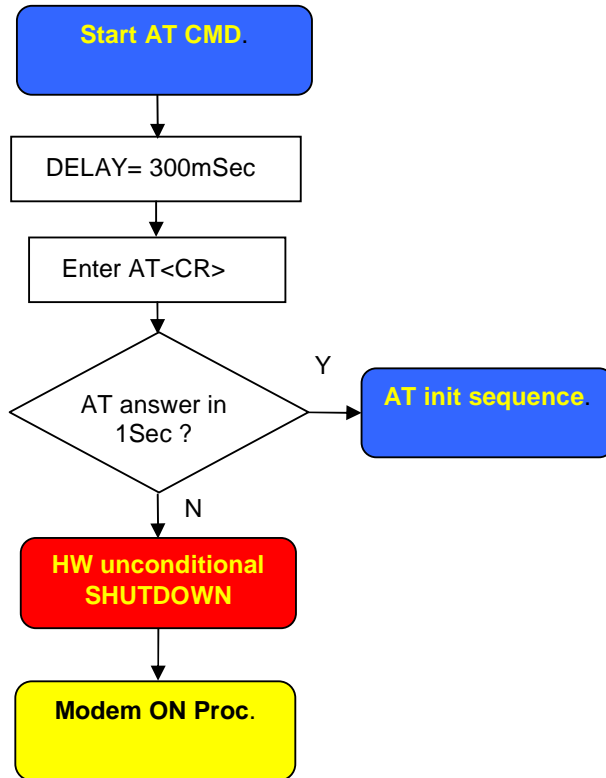

For example:

1- Let's assume you need to drive the ON* pad with a totem pole output of a +3/5 V microcontroller:

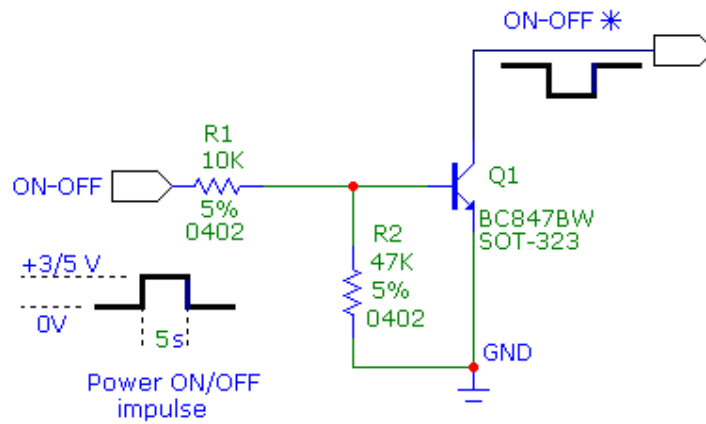

2- Let's assume you need to drive the ON* pad directly with an ON/OFF button:

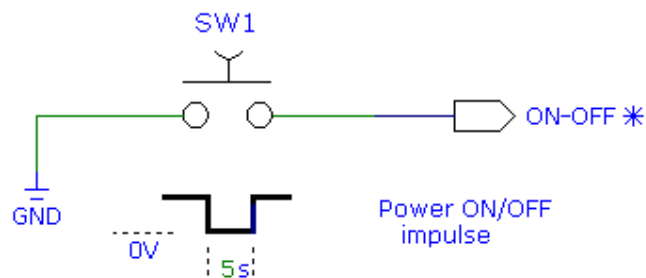

4.2. Turning OFF the GE910

Turning off of the device can be done in two ways:

- via AT command (see GE910 Software User Guide, AT#SHDN)
- by tying low pin ON*

Either ways, the device issues a detach request to network informing that the device will not be reachable any more.

To turn OFF the GE910 the pad ON* must be tied low for at least 2 seconds and then released. A Pulse duration less than 2 seconds should also start the power off procedure, but this is not guaranteed.

The same circuitry and timing for the power on must be used.

The device shuts down after the release of the ON* pad.



TIP:

To check if the device has been powered off, the hardware line PWRMON must be monitored. The device is powered off when PWRMON goes low.



NOTE:

In order to avoid a back powering effect it is recommended to avoid having any HIGH logic level signal applied to the digital pins of the GE910 when the module is powered off or during an ON/OFF transition.



The following flow chart shows the proper turnoff procedure:

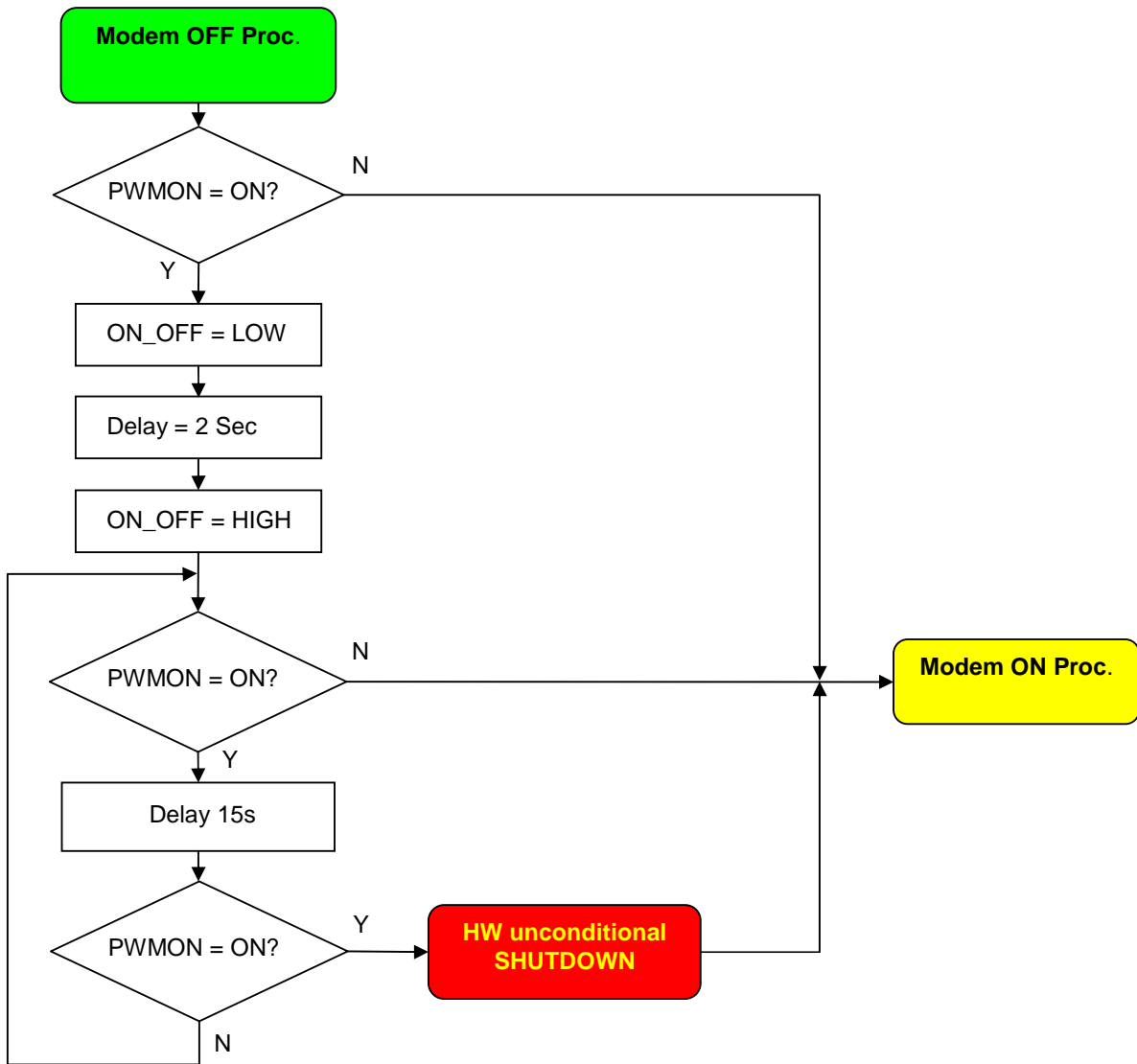

4.3. HW Unconditional Shutdown on GE910

4.3.1. Hardware Unconditional shutdown



WARNING:

The hardware unconditional Shutdown must not be used during normal operation of the device since it does not detach the device from the network. It shall be kept as an emergency exit procedure to be done in the rare case that the device gets stacked waiting for some network or SIM responses.

To unconditionally Shutdown the GE910, the pad HW_SHUTDOWN* must be tied low for at least 200 milliseconds and then released. After this operation the module is in OFF condition. The maximum current that can be drained from the HW_SHUTDOWN* pad is 0,4 mA.



NOTE:

Do not use any pull up resistor on the HW_SHUTDOWN* line or any totem pole digital output. Using pull up resistor may bring to latch up problems on the GE910 power regulator and improper functioning of the module. The line HW_SHUTDOWN* must be connected only in open collector configuration.

TIP:

The unconditional hardware shutdown must always be implemented on the boards and the software must use it as an emergency exit procedure.

A simple circuit to do it is:

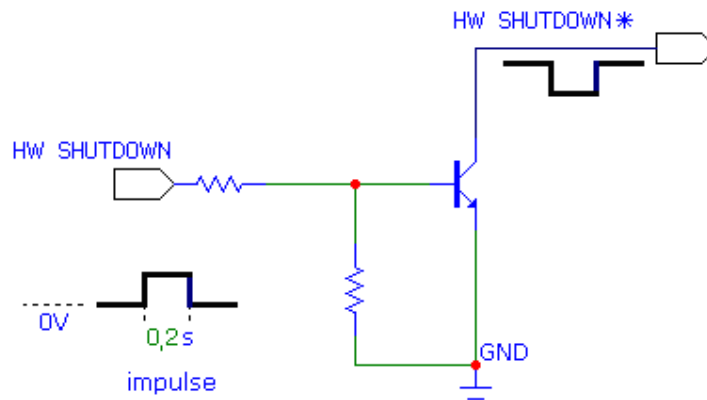

In the following flow chart is detailed the proper restart procedure:

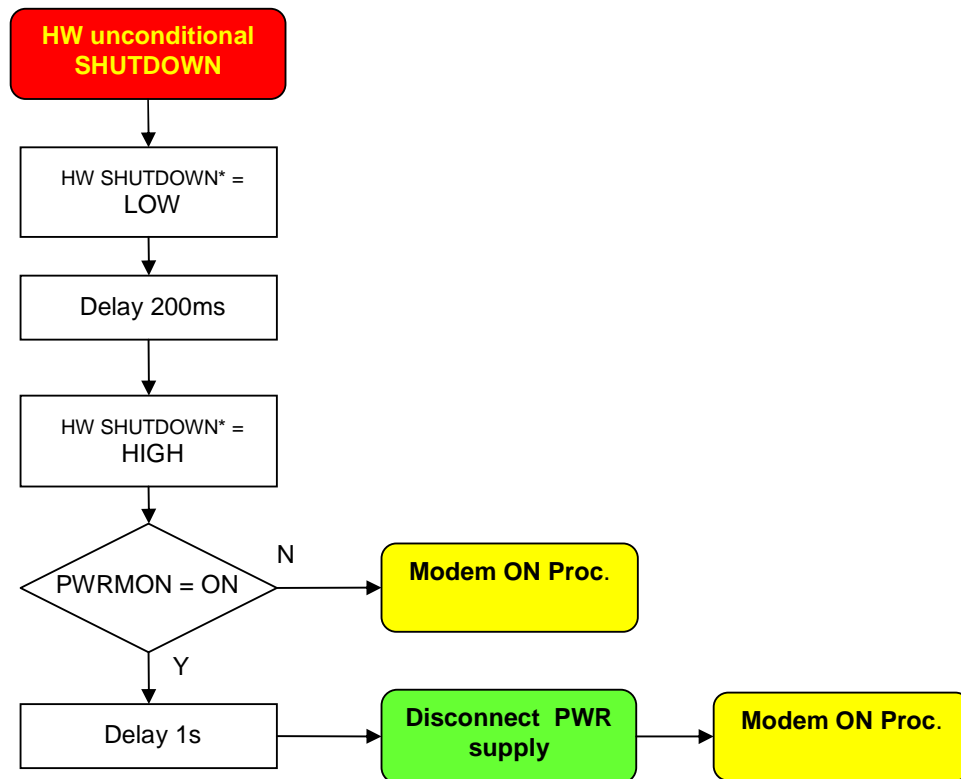

NOTE:

In order to avoid a back powering effect it is recommended to avoid having any HIGH logic level signal applied to the digital pins of the GE910 when the module is powered off or during an ON/OFF transition.



For example:

1. Let us assume you need to drive the HW_SHUTDOWN* pad with a totem pole output of a +3/5 V microcontroller:

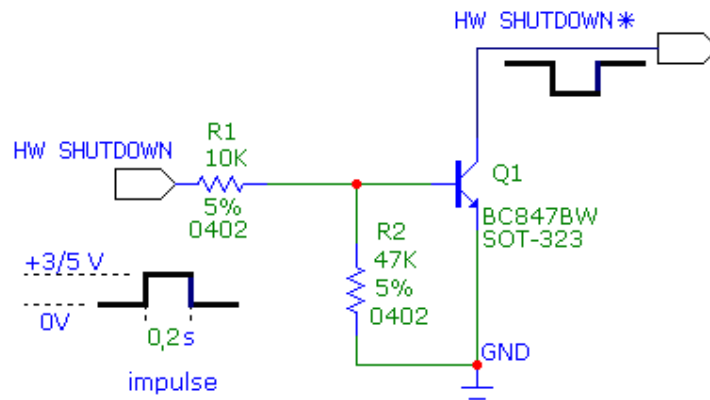

5. Power Supply

The power supply circuitry and board layout are a very important part in the full product design and they strongly reflect on the product overall performances, hence read carefully the requirements and the guidelines that will follow for a proper design.

5.1. Power Supply Requirements

The external power supply must be connected to VBATT & VBATT_PA signals and must fulfill the following requirements:

POWER SUPPLY	
Nominal Supply Voltage	3.8 V
Normal Operating Voltage Range	3.40 V ÷ 4.20 V
Extended Operating Voltage Range	3.20 V ÷ 4.50 V



NOTE:

The Operating Voltage Range **MUST** never be exceeded; care must be taken in order to fulfil min/max voltage requirement.



NOTE:

Overshoot voltage (regarding MAX Extended Operating Voltage) and drop in voltage (regarding MIN Extended Operating Voltage) **MUST** never be exceeded;

The “Extended Operating Voltage Range” can be used only with completely assumption and application of the HW User guide suggestions.



5.2. Power Consumption

The GE910 power consumptions are:

GE910		
Mode	Average (mA)	Mode description
SWITCHED OFF		
Switched Off	Typical 60uA	Module supplied but Switched Off
IDLE mode		
AT+CFUN=1	21	Normal mode: full functionality of the module
AT+CFUN=4	18	Disabled TX and RX; module is not registered on the network
AT+CFUN=0 or =5	3,8	Paging Multiframe 2
	2,5	Paging Multiframe 3
	2,4	Paging Multiframe 4
	1,2	Paging Multiframe 9
CSD TX and RX mode		
GSM900 CSD PL5	230	GSM VOICE CALL
DCS1800 CSD PL0	175	
GPRS (class 1) 1TX + 1RX		
GSM900 PL5	225	GPRS Sending data mode
DCS1800 PL0	160	
GPRS (class 10) 2TX + 3RX		
GSM900 PL5	360	GPRS Sending data mode
DCS1800 PL0	290	

The GSM system is made in a way that the RF transmission is not continuous, else it is packed into bursts at a base frequency of about 216 Hz, and the relative current peaks can be as high as about 2A. Therefore the power supply has to be designed in order to withstand with these current peaks without big voltage drops; this means that both the electrical design and the board layout must be designed for this current flow.

If the layout of the PCB is not well designed a strong noise floor is generated on the ground and the supply; this will reflect on all the audio paths producing an audible annoying noise at 216 Hz; if the voltage drop during the peak current absorption is too much, then the device may even shutdown as a consequence of the supply voltage drop.



NOTE:

The electrical design for the Power supply should be made ensuring it will be capable of a peak current output of at least 2 A.



5.3. General Design Rules

The principal guidelines for the Power Supply Design embrace three different design steps:

- the electrical design
- the thermal design
- the PCB layout.

5.3.1. Electrical Design Guidelines

The electrical design of the power supply depends strongly from the power source where this power is drained. We will distinguish them into three categories:

- +5V input (typically PC internal regulator output)
- +12V input (typically automotive)
- Battery

5.3.1.1. + 5V input Source Power Supply Design Guidelines

- The desired output for the power supply is 3.8V, hence there's not a big difference between the input source and the desired output and a linear regulator can be used. A switching power supply will not be suited because of the low drop out requirements.
- When using a linear regulator, a proper heat sink shall be provided in order to dissipate the power generated.
- A Bypass low ESR capacitor of adequate capacity must be provided in order to cut the current absorption peaks close to the GE910, a 100µF tantalum capacitor is usually suited.
- Make sure the low ESR capacitor on the power supply output (usually a tantalum one) is rated at least 10V.
- A protection diode should be inserted close to the power input, in order to save the GE910 from power polarity inversion.

An example of linear regulator with 5V input is:

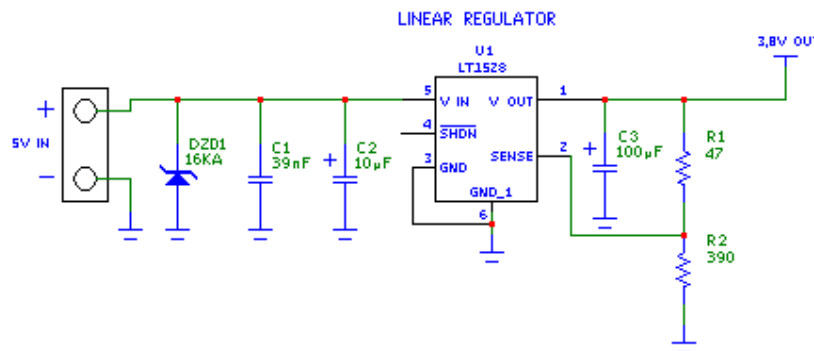

5.3.1.2. + 12V input Source Power Supply Design Guidelines

- The desired output for the power supply is 3.8V, hence due to the big difference between the input source and the desired output, a linear regulator is not suited and shall not be used. A switching power supply will be preferable because of its better efficiency especially with the 2A peak current load represented by the GE910.
- When using a switching regulator, a 500kHz or more switching frequency regulator is preferable because of its smaller inductor size and its faster transient response. This allows the regulator to respond quickly to the current peaks absorption.
- In any case the frequency and Switching design selection is related to the application to be developed due to the fact the switching frequency could also generate EMC interferences.
- For car PB battery the input voltage can rise up to 15,8V and this should be kept in mind when choosing components: all components in the power supply must withstand this voltage.
- A Bypass low ESR capacitor of adequate capacity must be provided in order to cut the current absorption peaks, a 100µF tantalum capacitor is usually suited.
- Make sure the low ESR capacitor on the power supply output (usually a tantalum one) is rated at least 10V.
- For Car applications a spike protection diode should be inserted close to the power input, in order to clean the supply from spikes.
- A protection diode should be inserted close to the power input, in order to save the GE910 from power polarity inversion. This can be the same diode as for spike protection.

An example of switching regulator with 12V input is in the below schematic:

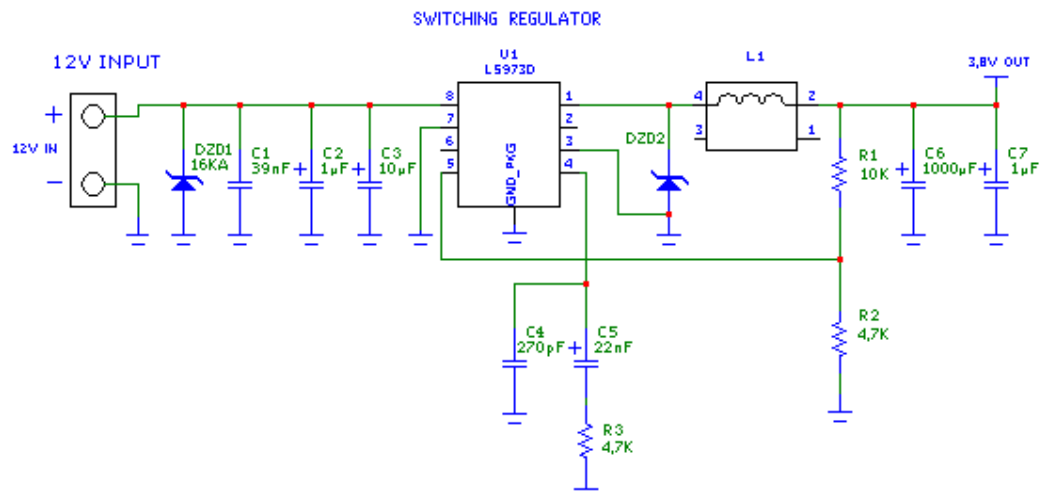

5.3.1.3. Battery Source Power Supply Design Guidelines

- The desired nominal output for the power supply is 3.8V and the maximum voltage allowed is 4.2V, hence a single 3.7V Li-Ion cell battery type is suited for supplying the power to the Telit GE910 module.



WARNING:

The three cells Ni/Cd or Ni/MH 3,6 V Nom. battery types or 4V PB types **MUST NOT BE USED DIRECTLY** since their maximum voltage can rise over the absolute maximum voltage for the GE910 and damage it.



NOTE:

DON'T USE any Ni-Cd, Ni-MH, and Pb battery types directly connected with GE910. Their use can lead to overvoltage on the GE910 and damage it. USE ONLY Li-Ion battery types.

- A Bypass low ESR capacitor of adequate capacity must be provided in order to cut the current absorption peaks, a 100 μ F tantalum capacitor is usually suited.
- Make sure the low ESR capacitor (usually a tantalum one) is rated at least 10V.
- A protection diode should be inserted close to the power input, in order to save the GE910 from power polarity inversion. Otherwise the battery connector should be done in a way to avoid polarity inversions when connecting the battery.
- The battery capacity must be at least 500mAh in order to withstand the current peaks of 2A; the suggested capacity is from 500mAh to 1000mAh.



5.3.2. Thermal Design Guidelines

The thermal design for the power supply heat sink should be done with the following specifications:

See para 6.2 Power Consumption



NOTE:

The average consumption during transmissions depends on the power level at which the device is requested to transmit by the network. The average current consumption hence varies significantly.

Considering the very low current during idle, especially if Power Saving function is enabled, it is possible to consider from the thermal point of view that the device absorbs current significantly only during calls.

For the heat generated by the GE910, you can consider it to be during transmission 1W max during CSD/VOICE calls and 2W max during class10 GPRS upload.

This generated heat will be mostly conducted to the ground plane under the GE910; you must ensure that your application can dissipate it.



5.3.3. Power Supply PCB layout Guidelines

As seen on the electrical design guidelines the power supply shall have a low ESR capacitor on the output to cut the current peaks and a protection diode on the input to protect the supply from spikes and polarity inversion. The placement of these components is crucial for the correct working of the circuitry. A misplaced component can be useless or can even decrease the power supply performances.

- The Bypass low ESR capacitor must be placed close to the Telit GE910 power input pads or in the case the power supply is a switching type it can be placed close to the inductor to cut the ripple provided the PCB trace from the capacitor to the GE910 is wide enough to ensure a dropleless connection even during the 2A current peaks.
- The protection diode must be placed close to the input connector where the power source is drained.
- The PCB traces from the input connector to the power regulator IC must be wide enough to ensure no voltage drops occur when the 2A current peaks are absorbed. Note that this is not made in order to save power loss but especially to avoid the voltage drops on the power line at the current peaks frequency of 216 Hz that will reflect on all the components connected to that supply, introducing the noise floor at the burst base frequency. For this reason while a voltage drop of 300-400 mV may be acceptable from the power loss point of view, the same voltage drop may not be acceptable from the noise point of view. If your application doesn't have audio interface but only uses the data feature of the Telit GE910, then this noise is not so disturbing and power supply layout design can be more forgiving.
- The PCB traces to the GE910 and the Bypass capacitor must be wide enough to ensure no significant voltage drops occur when the 2A current peaks are absorbed. This is for the same reason as previous point. Try to keep this trace as short as possible.
- The PCB traces connecting the Switching output to the inductor and the switching diode must be kept as short as possible by placing the inductor and the diode very close to the power switching IC (only for switching power supply). This is done in order to reduce the radiated field (noise) at the switching frequency (100-500 kHz usually).
- The use of a good common ground plane is suggested.
- The placement of the power supply on the board should be done in such a way to guarantee that the high current return paths in the ground plane are not overlapped to any noise sensitive circuitry as the microphone amplifier/buffer or earphone amplifier.
- The power supply input cables should be kept separate from noise sensitive lines such as microphone/earphone cables.



6. Antenna

The antenna connection and board layout design are the most important aspect in the full product design as they strongly affect the product overall performances, hence read carefully and follow the requirements and the guidelines for a proper design.

6.1. GSM Antenna Requirements

As suggested on the Product Description the antenna and antenna transmission line on PCB for a Telit GE910 device shall fulfill the following requirements:

ANTENNA REQUIREMENTS	
Frequency range	Depending by frequency band(s) provided by the network operator, the customer shall use the most suitable antenna for that/those band(s)
Bandwidth	70 MHz in GSM850, 80 MHz in GSM900, 170 MHz in DCS & 140 MHz PCS band
Gain	1.4dBi @900 and 3dBi @1800 1.4dBi @850 and 3dBi @1900
Impedance	50Ω
Input power	> 2 W
VSWR absolute max	≤ 10:1 (limit to avoid permanent damage)
VSWR recommended	≤ 2:1 (limit to fulfil all regulatory requirements)

When using the GE910, since there's no antenna connector on the module, the antenna must be connected to the GE910 antenna pad (LGA pad K1) by means of a transmission line implemented on the PCB.

In the case the antenna is not directly connected at the antenna pad of the GE910, then a PCB line is needed in order to connect with it or with its connector.

This transmission line shall fulfill the following requirements:

ANTENNA LINE ON PCB REQUIREMENTS	
Characteristic Impedance	50Ω
Max Attenuation	0,3 dB
Coupling with other signals shall be avoided	
Cold End (Ground Plane) of antenna shall be equipotential to the GE910 ground pins	



Furthermore if the device is developed for the US market and/or Canada market, it shall comply with the FCC and/or IC approval requirements:

This device is to be used only for mobile and fixed application. In order to re-use the Telit FCC/IC approvals the antenna(s) used for this transmitter must be installed to provide a separation distance of at least 20 cm from all persons and must not be co-located or operating in conjunction with any other antenna or transmitter. If antenna is installed with a separation distance of less than 20 cm from all persons or is co-located or operating in conjunction with any other antenna or transmitter then additional FCC/IC testing may be required. End-Users must be provided with transmitter operation conditions for satisfying RF exposure compliance. Antennas used for this OEM module must not exceed 3dBi gain for mobile and fixed operating configurations.

6.2. GSM Antenna - PCB line Guidelines

- Make sure that the transmission line's characteristic impedance is 50Ω ;
- Keep line on the PCB as short as possible, since the antenna line loss shall be less than around 0,3 dB;
- Line geometry should have uniform characteristics, constant cross section, avoid meanders and abrupt curves;
- Any kind of suitable geometry / structure (Microstrip, Stripline, Coplanar, Grounded Coplanar Waveguide...) can be used for implementing the printed transmission line afferent the antenna;
- If a Ground plane is required in line geometry, that plane has to be continuous and sufficiently extended, so the geometry can be as similar as possible to the related canonical model;
- Keep, if possible, at least one layer of the PCB used only for the Ground plane; If possible, use this layer as reference Ground plane for the transmission line;
- It is wise to surround (on both sides) the PCB transmission line with Ground, avoid having other signal tracks facing directly the antenna line track.
- Avoid crossing any un-shielded transmission line footprint with other signal tracks on different layers;
- The ground surrounding the antenna line on PCB has to be strictly connected to the main Ground Plane by means of via holes (once per 2mm at least), placed close to the ground edges facing line track;
- Place EM noisy devices as far as possible from GE910 antenna line;
- Keep the antenna line far away from the GE910 power supply lines;
- If EM noisy devices are present on the PCB hosting the GE910, such as fast switching ICs, take care of the shielding of the antenna line by burying it inside the layers of PCB and surround it with Ground planes, or shield it with a metal frame cover.
- If EM noisy devices are not present around the line, the use of geometries like Microstrip or Grounded Coplanar Waveguide has to be preferred, since they typically ensure less attenuation if compared to a Stripline having same length;



6.3. PCB Guidelines in case of FCC certification

In the case FCC certification is required for an application using GE910, according to FCC KDB 996369 for modular approval requirements, the transmission line has to be similar to that implemented on GE910 interface board and described in the following chapter.

6.3.1. Transmission line design

During the design of the GE910 interface board, the placement of components has been chosen properly, in order to keep the line length as short as possible, thus leading to lowest power losses possible. A Grounded Coplanar Waveguide (G-CPW) line has been chosen, since this kind of transmission line ensures good impedance control and can be implemented in an outer PCB layer as needed in this case. A SMA female connector has been used to feed the line.

The interface board is realized on a FR4, 4-layers PCB. Substrate material is characterized by relative permittivity $\epsilon_r = 4.6 \pm 0.4 @ 1 \text{ GHz}$, $\text{TanD} = 0.019 \div 0.026 @ 1 \text{ GHz}$.

A characteristic impedance of nearly 50Ω is achieved using trace width = 1.1 mm, clearance from coplanar ground plane = 0.3 mm each side. The line uses reference ground plane on layer 3, while copper is removed from layer 2 underneath the line. Height of trace above ground plane is 1.335 mm. Calculated characteristic impedance is 51.6Ω , estimated line loss is less than 0.1 dB. The line geometry is shown below:

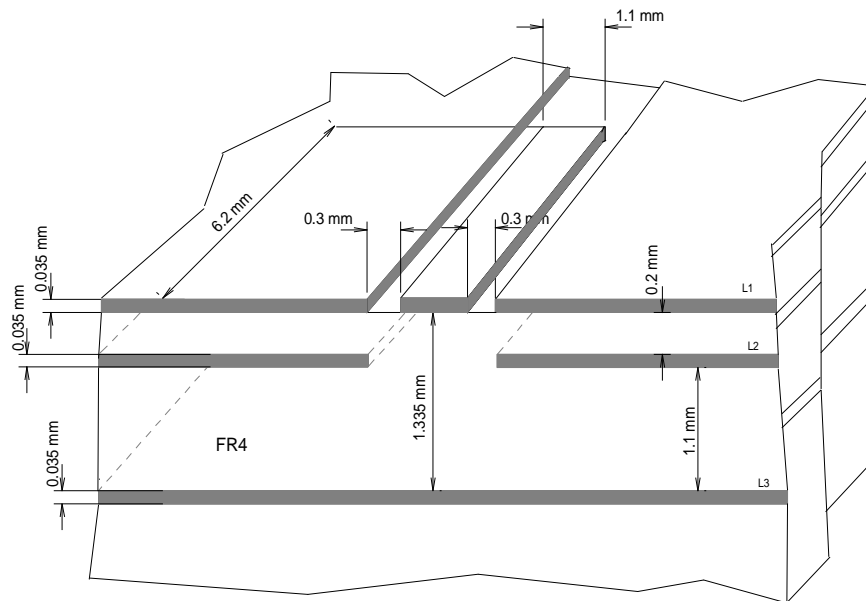

6.3.2. Transmission line measurements

HP8753E VNA (Full-2-port calibration) has been used in this measurement session. A calibrated coaxial cable has been soldered at the pad corresponding to GE910 RF output; a SMA connector has been soldered to the board in order to characterize the losses of the transmission line including the connector itself. During Return Loss / impedance measurements, the transmission line has been terminated to 50 Ω load.

Return Loss plot of line under test is shown below:

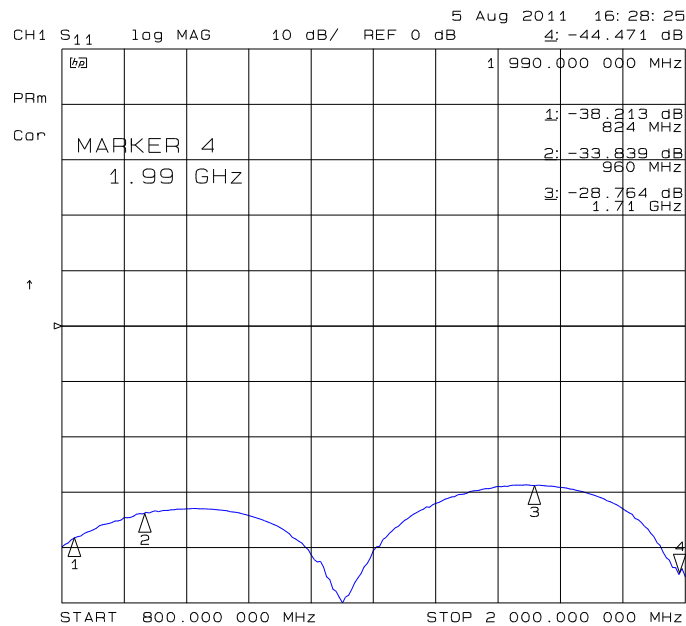

GE910 Hardware User Guide
1v0300962 Rev.4 2012-06-25

Line input impedance (in Smith Chart format, once the line has been terminated to 50 Ω load) is shown in the following figure:

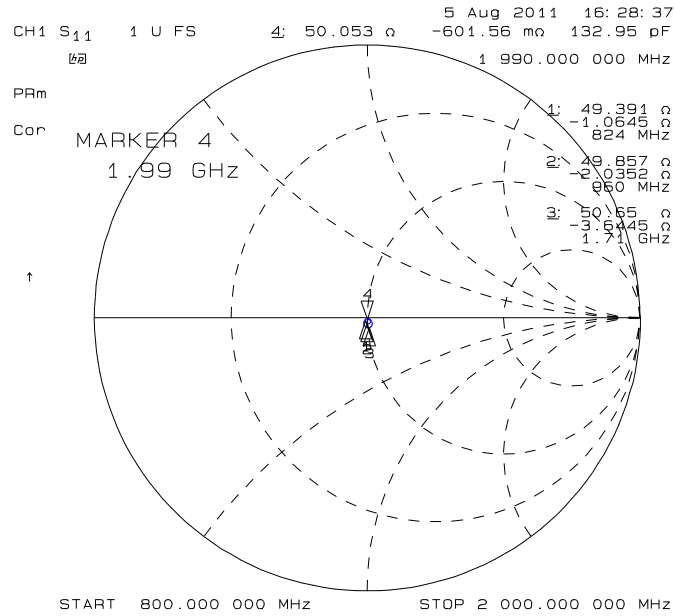

Insertion Loss of G-CPW line plus SMA connector is shown below:

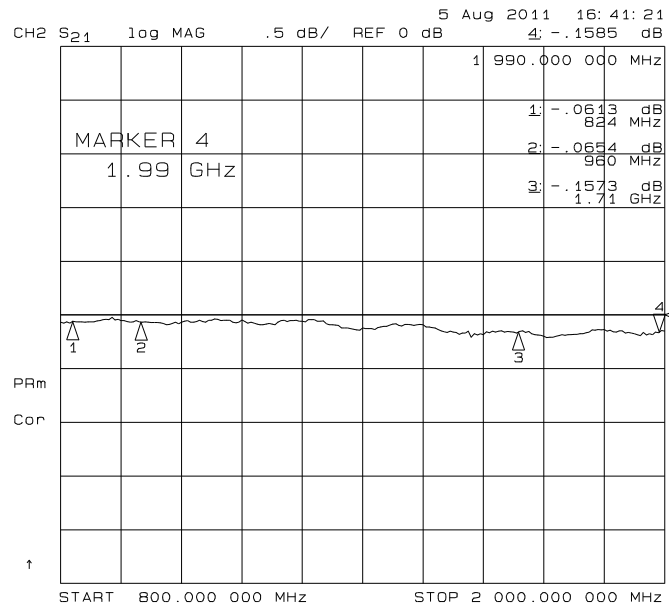

6.4. GSM Antenna - Installation Guidelines

- Install the antenna in a place covered by the GSM signal.
- If the device antenna is located greater than 20cm from the human body and there are no co-located transmitter then the Telit FCC/IC approvals can be re-used by the end product
- If the device antenna is located less than 20cm from the human body or there are no co-located transmitter then the additional FCC/IC testing may be required for the end product (Telit FCC/IC approvals cannot be reused)
- Antenna shall not be installed inside metal cases
- Antenna shall be installed also according to Antenna manufacturer instructions.



7. Logic level specifications

Where not specifically stated, all the interface circuits work at 1.8V CMOS logic levels. The following table shows the logic level specifications used in the GE910 interface circuits:

Absolute Maximum Ratings -Not Functional

Parameter	Min	Max
Input level on any digital pin (CMOS 1.8) when on	-0.3V	+2.1V

Operating Range - Interface levels (1.8V CMOS)

Level	Min	Max
Input high level	1.5V	1.9V
Input low level	0V	0.35V
Output high level	1.6V	1.9V
Output low level	0V	0.2V

Current characteristics

Level	Typical
Output Current	1mA
Input Current	1uA



7.1. Unconditional Shutdown

Signal	Function	I/O	Pin
HW_SHUTDOWN*	Hardware unconditional Shutdown	I	R13

HW_SHUTDOWN* is used to unconditionally shutdown the GE910. Whenever this signal is pulled low, the GE910 is unconditionally shutdown. When the device is reset it stops any operation. After the release of the HW_SHUTDOWN* pin, the GE910 is unconditionally shut down, without doing any detach operation from the network where it is registered. This behavior is not a proper shut down because any GSM device is requested to issue a detach request on turn off. For this reason the unconditional shutdown pin HW_SHUTDOWN* signal must not be used to normally shutting down the device, but only as an emergency exit in the rare case the device remains stuck waiting for some network response.

After the unconditional shutdown pin HW_SHUTDOWN* used the module is in off status. It may only be used to reset a device already on that is not responding to any command.



NOTE:

Do not use this signal to power off the GE910. Use the ON/OFF signal to perform this function or the AT#SHDN command.

This signal is internally pulled up so the pin can be left floating if not used.



NOTE:

if used, then it must always be connected with an open collector transistor.



8. Serial Ports

The serial port on the GE910 is the core of the interface between the module and OEM hardware. 2 serial ports are available on the module:

- MODEM SERIAL PORT 1 (Main, ASC0)
- MODEM SERIAL PORT 2 (Auxiliary, ASC1)

8.1. MODEM SERIAL PORT

Several configurations can be designed for the serial port on the OEM hardware, but the most common are:

- RS232 PC com port
- microcontroller UART @ 1.8V (Universal Asynchronous Receive Transmit)
- microcontroller UART @ 3V or other voltages different from 1.8V
- microcontroller UART @ 5V or other voltages different from 1.8V

Depending from the type of serial port on the OEM hardware a level translator circuit may be needed to make the system work. The only configuration that doesn't need a level translation is the 1.8V UART.

The serial port on the GE910 is a +1.8V UART with all the 7 RS232 signals. It differs from the PC-RS232 in the signal polarity (RS232 is reversed) and levels. The levels for the GE910 UART are the CMOS levels:

Absolute Maximum Ratings -Not Functional

Parameter	Min	Max
Input level on any digital pad when on	-0.3V	+2.1V
Input voltage on analog pads when on	-0.3V	+2.1V

Operating Range - Interface levels (1.8V CMOS)

Level	Min	Max
Input high level V_{IH}	1.5V	1.9V
Input low level V_{IL}	0V	0.35V
Output high level V_{OH}	1.6V	1.9V
Output low level V_{OL}	0V	0.2V



The signals of the GE910 serial port are:

RS232 Pin Number	Signal	GE910 Pad Number	Name	Usage
1	DCD - dcd_uart	N14	Data Carrier Detect	Output from the GE910 that indicates the carrier presence
2	RXD - tx_uart	M15	Transmit line *see Note	Output transmit line of GE910 UART
3	TXD -rx_uart	N15	Receive line *see Note	Input receive of the GE910 UART
4	DTR - dtr_uart	M14	Data Terminal Ready	Input to the GE910 that controls the DTE READY condition
5	GND	P13	Ground	ground
6	DSR - dsr_uart	P14	Data Set Ready	Output from the GE910 that indicates the module is ready
7	RTS -rts_uart	L14	Request to Send	Input to the GE910 that controls the Hardware flow control
8	CTS - cts_uart	P15	Clear to Send	Output from the GE910 that controls the Hardware flow control
9	RI - ri_uart	R14	Ring Indicator	Output from the GE910 that indicates the incoming call condition



NOTE:

According to V.24, RX/TX signal names are referred to the application side, therefore on the GE910 side these signal are on the opposite direction: TXD on the application side will be connected to the receive line (here named TXD/ rx_uart) of the GE910 serial port and viceversa for RX.



NOTE:

For a minimum implementation, only the TXD and RXD lines can be connected, the other lines can be left open provided a software flow control is implemented.



NOTE:

In order to avoid a back powering effect it is recommended to avoid having any HIGH logic level signal applied to the digital pins of the GE910 when the module is powered off or during an ON/OFF transition.



8.2. RS232 level translation

In order to interface the GE910 with a PC com port or a RS232 (EIA/TIA-232) application a level translator is required. This level translator must:

- invert the electrical signal in both directions;
- change the level from 0/1.8V to +15/-15V

Actually, the RS232 UART 16450, 16550, 16650 & 16750 chipsets accept signals with lower levels on the RS232 side (EIA/TIA-562), allowing a lower voltage-multiplying ratio on the level translator. Note that the negative signal voltage must be less than 0V and hence some sort of level translation is always required.

The simplest way to translate the levels and invert the signal is by using a single chip level translator. There are a multitude of them, differing in the number of drivers and receivers and in the levels (be sure to get a true RS232 level translator not a RS485 or other standards).

By convention the driver is the level translator from the 0-1.8V UART to the RS232 level. The receiver is the translator from the RS232 level to 0-1.8V UART.

In order to translate the whole set of control lines of the UART you will need:

- 5 drivers
- 3 receivers



NOTE:

The digital input lines working at 1.8V CMOS have an absolute maximum input voltage of 2.1V; therefore the level translator IC shall not be powered by the +3.8V supply of the module. Instead, it must be powered from a +1.8V (dedicated) power supply.



An example of RS232 level adaptation circuitry could be done using a MAXIM transceiver (MAX218).

In this case the chipset is capable to translate directly from 0/1.8V to the RS232 levels (Example done on 4 signals only).

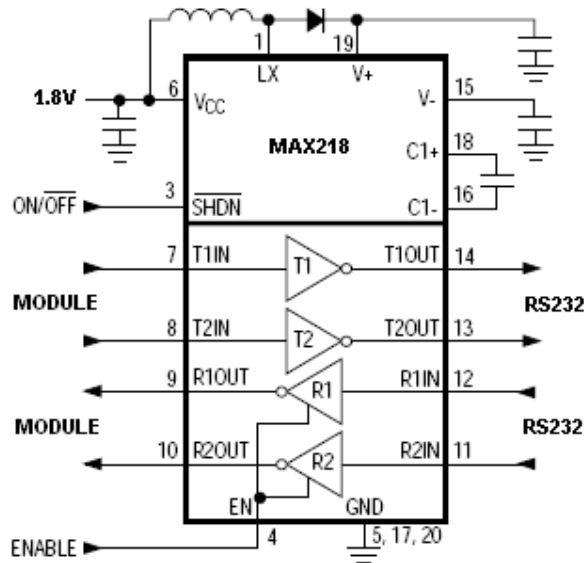

The RS232 serial port lines are usually connected to a DB9 connector with the following layout:

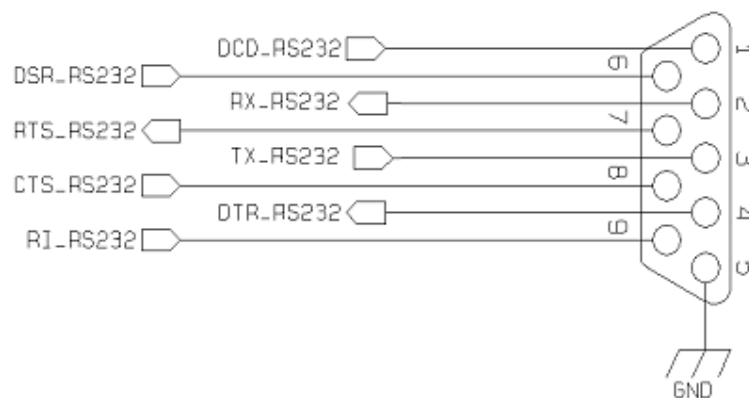

9. USB Port

The GE910 includes one integrated universal serial bus (USB) transceiver:

- USB 2.0 FS

9.1. USB 2.0 FS

This port is compliant with the USB 2.0 specifications.

The following table is listing the available signals:

PAD	Signal	I/O	Function	Type
B15	USB_D+	I/O	USB differential Data (+)	3.3V
C15	USB_D-	I/O	USB differential Data (-)	3.3V

The USB_DPLUS and USB_DMINUS signals have a clock rate of 12 MHz. The signal traces should be routed carefully. Trace lengths, number of vias and capacitive loading should be minimized. The impedance value should be as close as possible to 90 Ohms differential.



10. Audio Section Overview

The Base Band Chip of the GE910 provides one differential input for audio to be transmitted (*Uplink*) and a balanced BTL output for audio to be received (*downlink*).

The bias for the microphone has to be as clean as possible; the first connection (single ended) is preferable since the V_{mic} noise and ground noise are fed into the input as common mode and then rejected. This sounds strange; usually the connection to use in order to reject the common mode is the balanced one. In this situation we have to recall that the microphone is a sound to current transducer, so the resistor is the current to tension transducer, so finally the resistor feeds the input in balanced way even if the configuration, from a microphone point of view, seems to be un-balanced.

For more information refer to Telit document: "80000NT10007a Audio Settings Application Note".



10.1. MIC connection

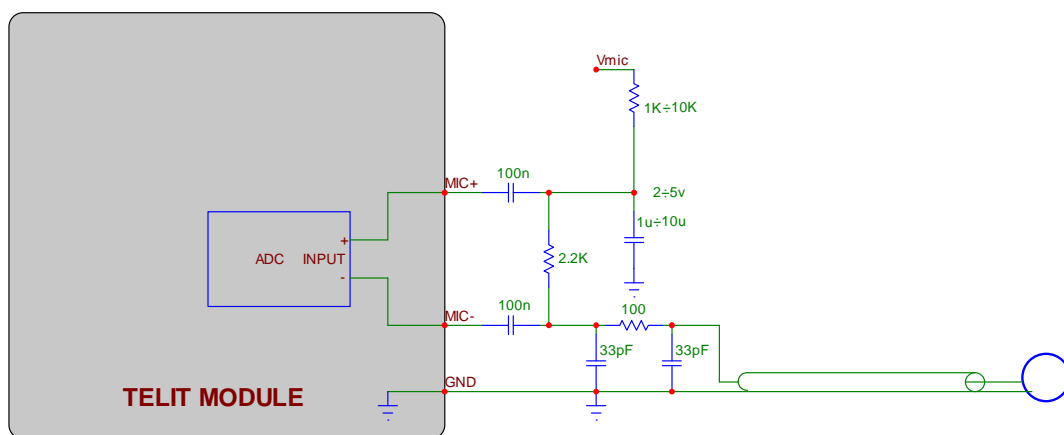

If a "balanced way" is anyway desired, much more care has to be taken to Vmic noise and ground noise; also the 33pF-100Ohm-33pF RF-filter has to be doubled (one each wire).

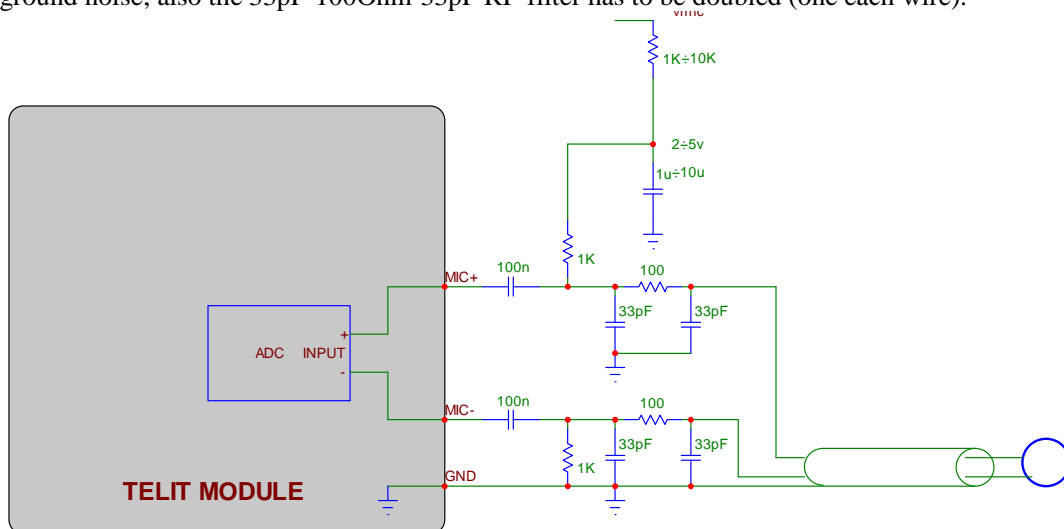

TIP: Since the J-FET transistor inside the microphone acts as RF-detector-amplifier, ask vendor for a microphone with anti-EMI capacitor (usually a 33pF or a 10pF capacitor placed across the output terminals inside the case).



10.2. LINE-IN connection

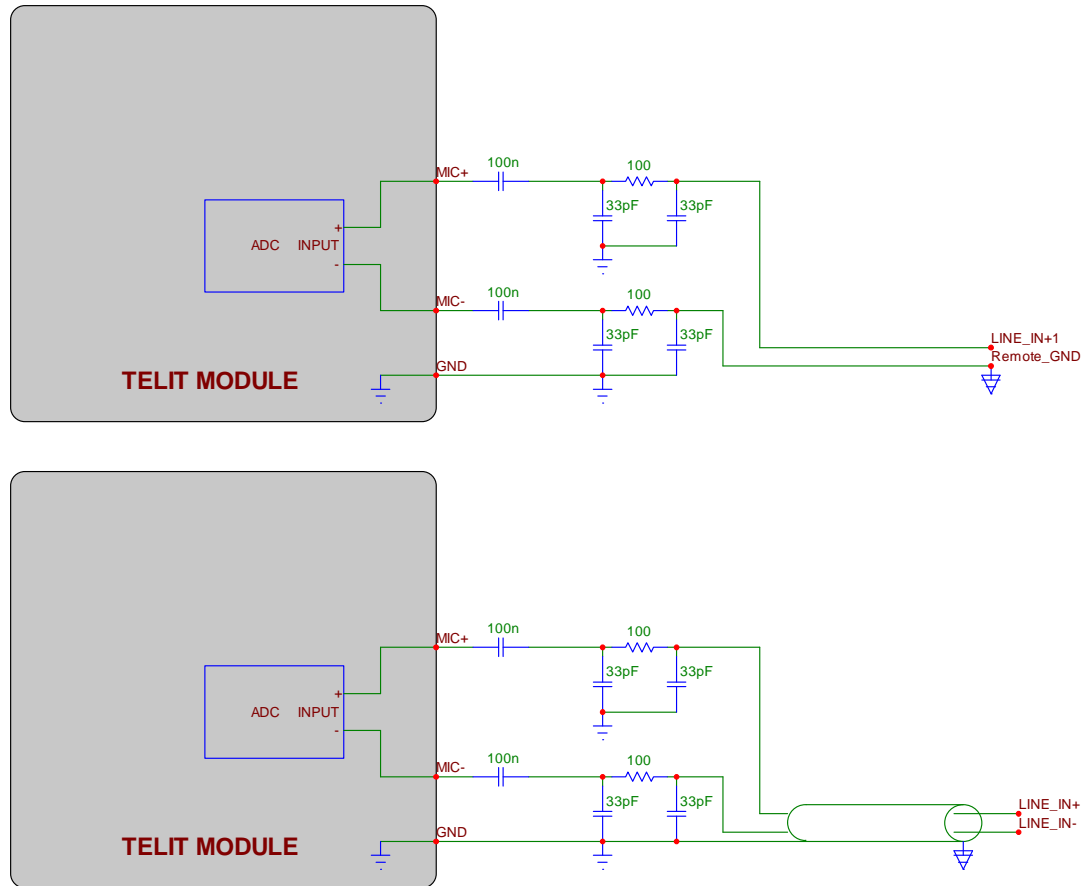

If the audio source is not a mike but a different device, the following connections can be done. Place 100nF capacitor in series with both inputs, so the DC current is blocked. Place the 33pF-100Ohm-33pF RF-filter, in order to prevent some EMI field to get into the high impedance high gain MIC inputs. Since the input is differential, the common mode voltage noise between the two (different) ground is rejected, provided that both AF_IN+ & AF_IN- are connected directly onto the source.



10.4. Electrical Characteristics

10.4.1. Input Lines

Microphone/Line-in path	
Line Type	Differential
Coupling capacitor	$\geq 100\text{nF}$
Differential input resistance	10k Ω
Levels	
To have 0dBm0 @ 1KHz (*)	Differential input voltage
AT#HFMICG=0	290mVrms
AT#HFMICG=1 (+6dB)	145mVrms
AT#HFMICG=2 (+12dB)	72mVrms
AT#HFMICG=3 (+18dB)	36mVrms
AT#HFMICG=4 (+24dB)	18mVrms
AT#HFMICG=5 (+30dB)	9mVrms
AT#HFMICG=6 (+36dB)	4.5mVrms
AT#HFMICG=7 (+42dB)	2.25mVrms

(*) 0 dBm0 in the network are -3.14 dBfs



TIP: The Electret microphone is internally amplified by a J-Fet transistor, thus the sound is carried out as saturation drain current; this means that the norton equivalence has to be considered. The signal is converted to voltage on the 2.2KOhm resistance, from there on circuitry has to be routed in order to not pick up common mode noise; beware of the return path (ground).



10.4.2. Output Lines

EAR/Line-out Output	
Differential line coupling	Direct connection ($V_{DC}=1.3\div 1.6V$)
Single-ended line coupling	One EAR terminal connected via a DC-block capacitor, the other one left open
output load resistance	$\geq 8 \Omega$
internal output resistance	4Ω (<i>typ.</i>)
signal bandwidth	$250\div 3400Hz$ (@ -3dB with default filter)
max. differential output voltage	$1120mV_{pp}$ @ 3.14dBm0 (*)
differential output voltage	$550mV_{rms}$ @ 0dBm0 (*)
volume increment	2dB per step
volume steps	0..10

(*) in default condition: AT+CLVL=10, AT#HFRECG=0



TIP : We suggest driving the load differentially; this kills all the common mode noises (click and pop, for example), the output swing will double (+6dB) and the big output coupling capacitor will be avoided.

However if particular OEM application needs, also a Single Ended (*S.E*) circuitry can be implemented. The OEM circuitry shall be designed to reduce the common mode noise typically generated by the return path of the big currents.

In order to get the maximum power output from the device, the resistance of the tracks has to be negligible in comparison to the load.



WARNING: When in *Single Ended* configuration, the unused output line must be left open: if this constraint is not respected, the output stage will be damaged.



11. General Purpose I/O

The general purpose I/O pads can be configured to act in three different ways:

- input
- output
- alternate function (*internally controlled*)

Input pads can be read; they report the digital value (*high or low*) present on the pad at the read time .

Output pads can only be written or queried and set the value of the pad output.

An *alternate function pad* is internally controlled by the GE910 firmware and acts depending on the function implemented.

The following table shows the available GPIO on the GE910 .

PAD	Signal	I/O	Function	Type	Drive strength	Default State	Note
C8	GPIO_01	I/O	Configurable GPIO	CMOS 1.8V	1 mA	INPUT	Alternate function STAT LED
C9	GPIO_02	I/O	Configurable GPIO	CMOS 1.8V	1 mA	INPUT	
C10	GPIO_03	I/O	Configurable GPIO	CMOS 1.8V	1 mA	INPUT	
C11	GPIO_04	I/O	Configurable GPIO	CMOS 1.8V	1 mA	INPUT	
B14	GPIO_05	I/O	Configurable GPIO	CMOS 1.8V	1 mA	INPUT	
C12	GPIO_06	I/O	Configurable GPIO	CMOS 1.8V	1 mA	INPUT	
C13	GPIO_07	I/O	Configurable GPIO	CMOS 1.8V	1 mA	INPUT	
K15	GPIO_08	I/O	Configurable GPIO	CMOS 1.8V	1 mA	INPUT	
L15	GPIO_09	I/O	Configurable GPIO	CMOS 1.8V	1 mA	INPUT	
G15	GPIO_10	I/O	Configurable GPIO	CMOS 1.8V	1 mA	INPUT	



11.1. GPIO Logic levels

Where not specifically stated, all the interface circuits work at 1.8V CMOS logic levels.
The following table shows the logic level specifications used in the GE910 interface circuits:

Absolute Maximum Ratings -Not Functional

Parameter	Min	Max
Input level on any digital pin (CMOS 1.8) when on	-0.3V	+2.1V

Operating Range - Interface levels (1.8V CMOS)

Level	Min	Max
Input high level	1.5V	1.9V
Input low level	0V	0.35V
Output high level	1.6V	1.9V
Output low level	0V	0.2V

Current characteristics

Level	Typical
Output Current	1mA
Input Current	1uA



11.2. Using a GPIO Pad as INPUT

The GPIO pads, when used as inputs, can be connected to a digital output of another device and report its status, provided this device has interface levels compatible with the 1.8V CMOS levels of the GPIO.

If the digital output of the device to be connected with the GPIO input pad has interface levels different from the 1.8V CMOS, then it can be buffered with an open collector transistor with a 47K pull up to 1.8V.



NOTE:

In order to avoid a back powering effect it is recommended to avoid having any HIGH logic level signal applied to the digital pins of the GE910 when the module is powered off or during an ON/OFF transition.

11.3. Using a GPIO Pad as OUTPUT

The GPIO pads, when used as outputs, can drive 1.8V CMOS digital devices or compatible hardware. When set as outputs, the pads have a push-pull output and therefore the pull-up resistor may be omitted.



11.4. Indication of network service availability

The STAT_LED pin status shows information on the network service availability and Call status. In the GE910 modules, the STAT_LED usually needs an external transistor to drive an external LED.

Therefore, the status indicated in the following table is reversed with respect to the pin status.

LED status	Device Status
Permanently off	Device off
Fast blinking (Period 1s, Ton 0,5s)	Net search / Not registered / turning off
Slow blinking (Period 3s, Ton 0,3s)	Registered full service
Permanently on	a call is active

A schematic example could be:

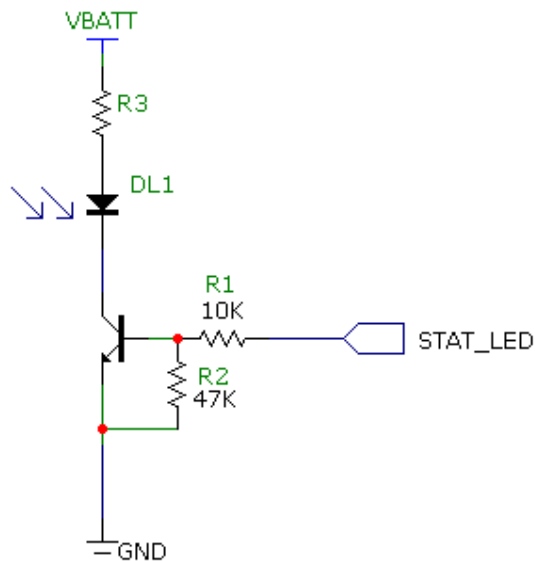

11.5. RTC Bypass out

The VRTC pin brings out the Real Time Clock supply, which is separate from the rest of the digital part, allowing having only RTC going on when all the other parts of the device are off. To this power output a backup capacitor can be added in order to increase the RTC autonomy during power off of the battery. NO Devices must be powered from this pin.



WARNING:

Never connect VRTC pin to VBATT.

11.6. External SIM Holder Implementation

Please refer to the related User Guide (SIM Holder Design Guides, 80000NT10001a).

11.7. ADC Converter

11.7.1. Description

The on board A/D are 10-bit converter. They are able to read a voltage level in the range of 0÷1,3 volts applied on the ADC pin input, store and convert it into 10 bit word.

	Min	Max	Units
Input Voltage range	0	1.3	Volt
AD conversion	-	10	bits
Resolution	-	< 1.3	mV

The input line is named as **ADC_IN1** and it is available on **PAD B1**.

11.7.2. Using ADC Converter

An AT command is available to use the ADC function.

The command is **AT#ADC=1,2**

The read value is expressed in mV

Refer to SW User Guide or AT Commands Reference Guide for the full description of this function.



12. Mounting the GE910 on your Board

12.1. General

The GE910 modules have been designed in order to be compliant with a standard lead-free SMT process.

12.2. Module finishing & dimensions

The GE910 overall dimensions are:

- Length: 28.2 mm
- Width: 28.2 mm
- Thickness: 2.70 mm
- Weight: 3.6 g

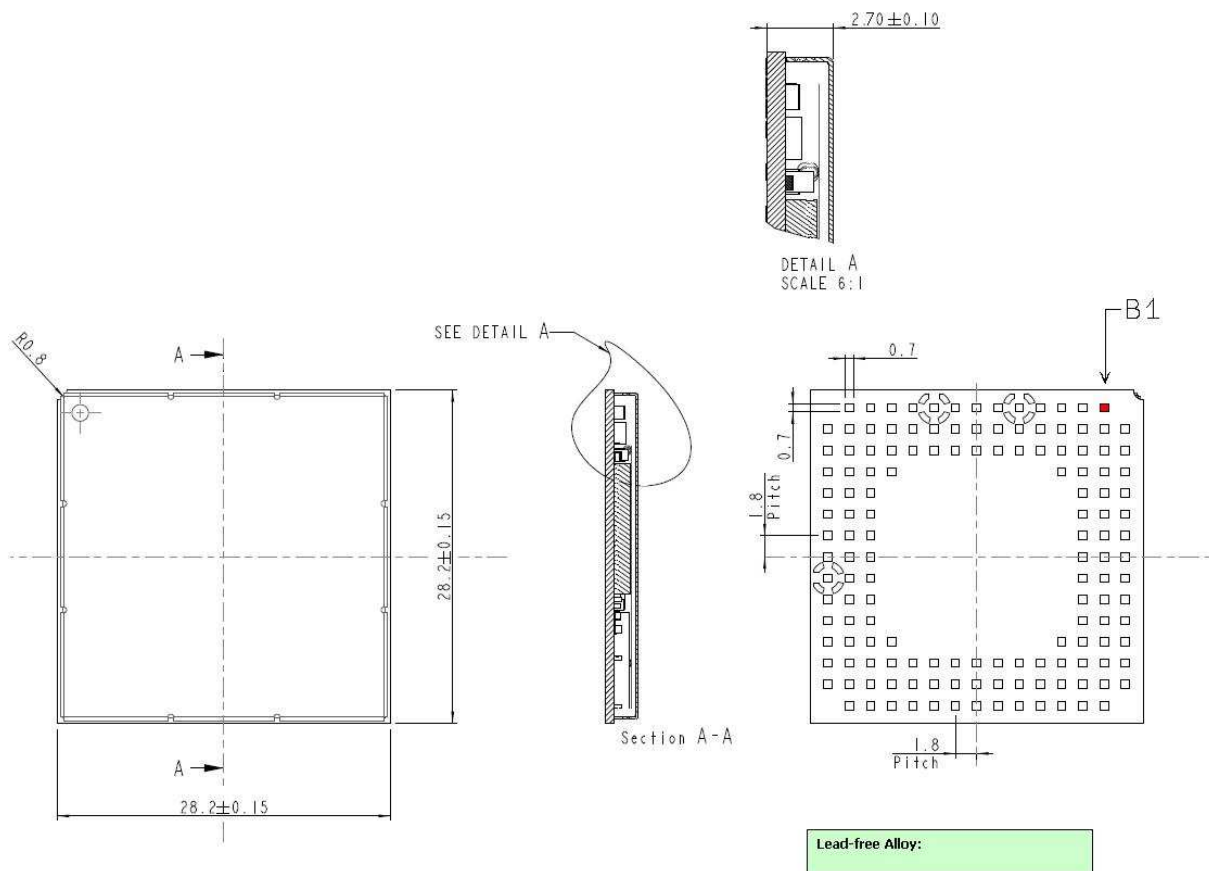

12.3. Recommended foot print for the application

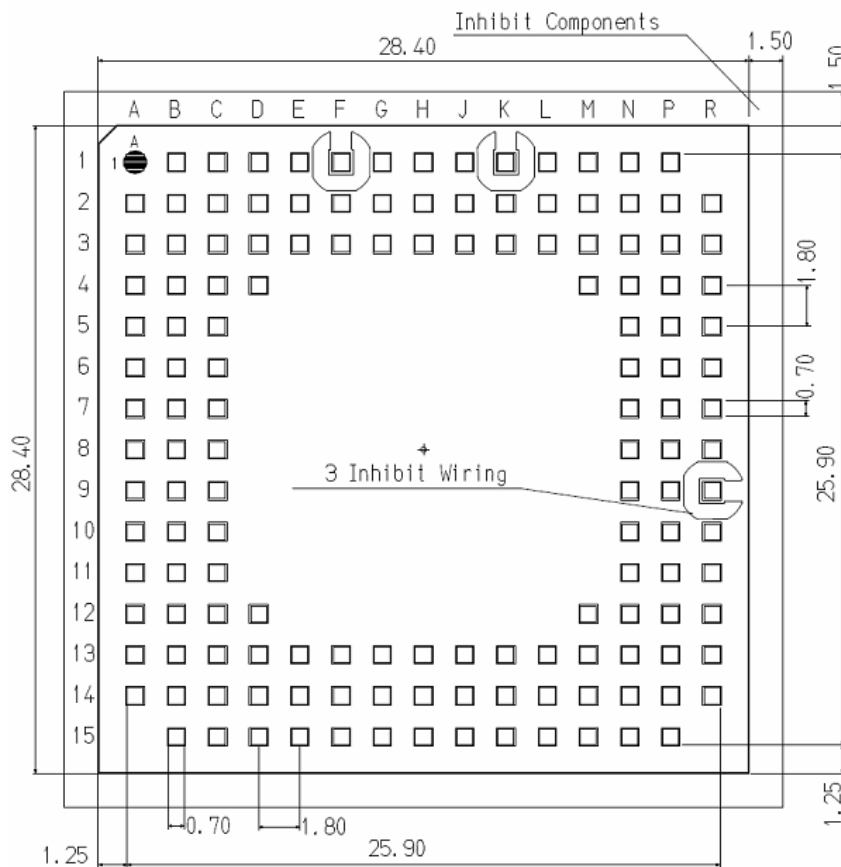

In order to easily rework the GE910 is suggested to consider on the application a 1.5mm Inhibit area around the module.
It is also suggested, as common rule for an SMT component, to avoid having a mechanical part of the application in direct contact with the module.



NOTE: In the customer application, the region under INHIBIT WIRING must be clear from signal or ground paths.



12.4. Stencil

Stencil's apertures layout can be the same of the recommended footprint (1:1), we suggest a thickness of stencil foil $\geq 120\mu\text{m}$.

12.5. PCB pad design

Non solder mask defined (NSMD) type is recommended for the solder pads on the PCB.

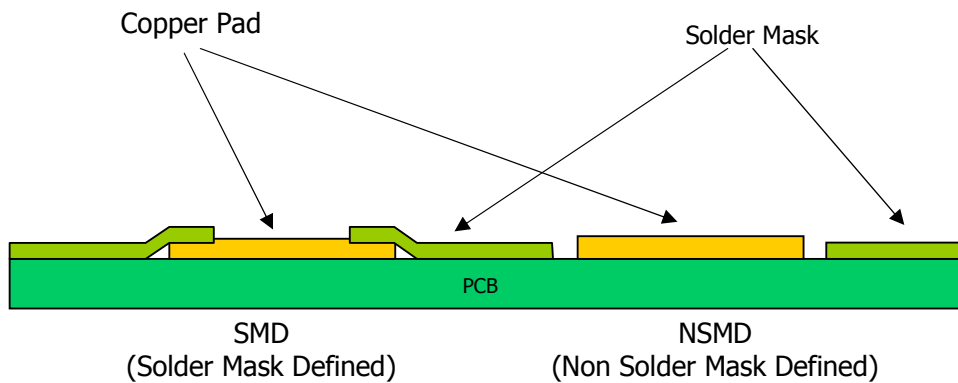

12.6. Recommendations for PCB pad dimensions (mm):

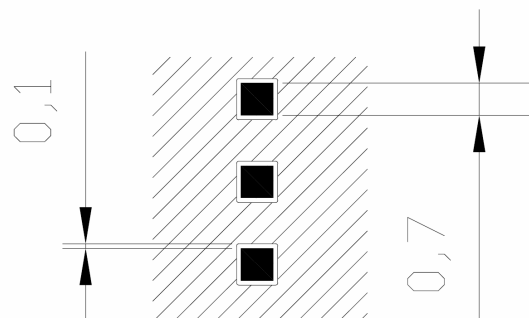

It is not recommended to place via or micro-via not covered by solder resist in an area of 0.3 mm around the pads unless it carries the same signal of the pad itself (see following figure).

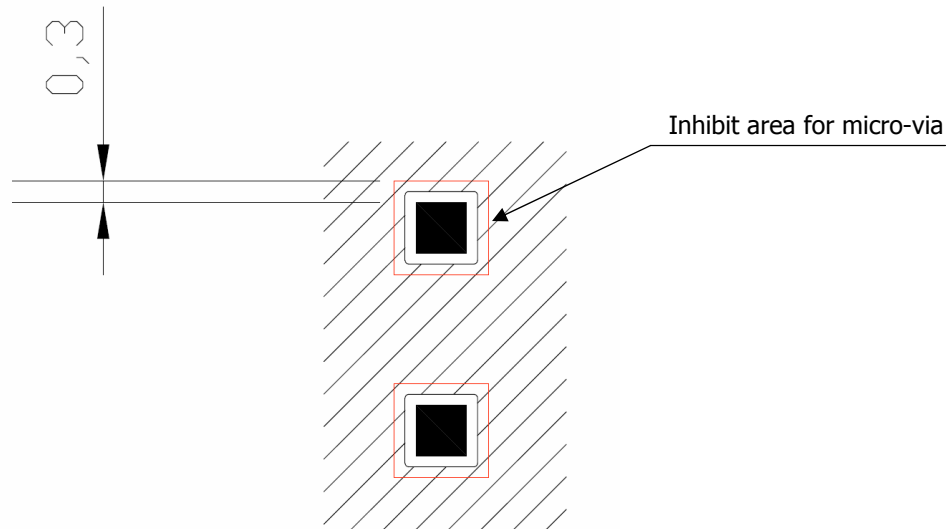

Holes in pad are allowed only for blind holes and not for through holes. When using the hole in pad, we suggest the via filling.
Recommendations for PCB pad surfaces:

Finish	Layer thickness [μm]	Properties
Electro-less Ni / Immersion Au	3 – 7 / 0.05 – 0.15	good solder ability protection, high shear force values

The PCB must be able to resist the higher temperatures which are occurring at the lead-free process. This issue should be discussed with the PCB-supplier. Generally, the wettability of tin-lead solder paste on the described surface plating is better compared to lead-free solder paste.



12.7. Solder paste

	Lead free
Solder paste	Sn/Ag/Cu

We recommend to use only “no clean” solder paste in order to avoid the cleaning of the modules after assembly.

12.7.1. GE910 Solder reflow

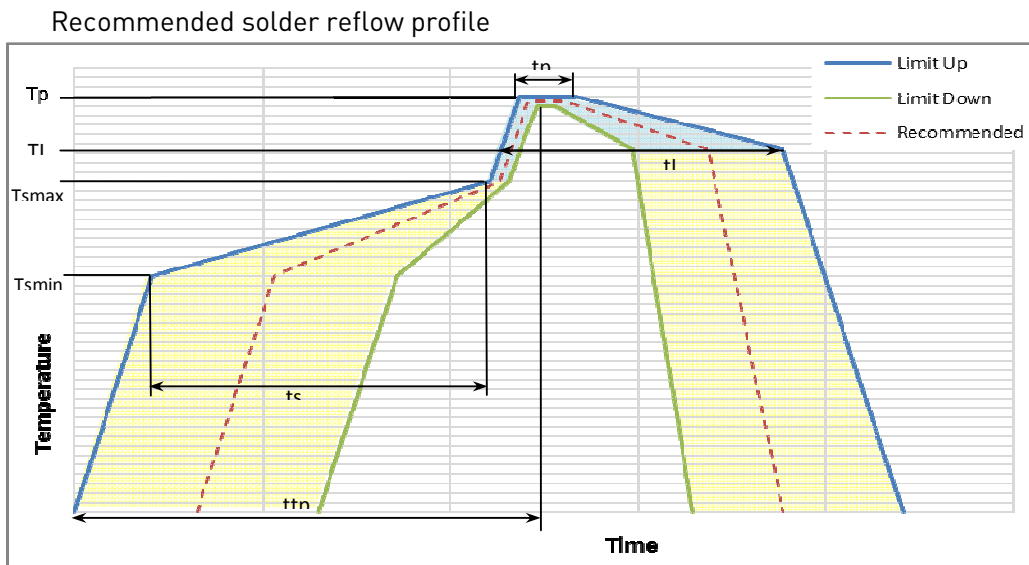

Profile Feature	Pb-Free Assembly
Average ramp-up rate (TL to TP)	3°C/second max
Preheat	
- Temperature Min (T _{min})	150°C
- Temperature Max (T _{max})	200°C
- Time (min to max) (t _s)	60-180 seconds
T _{max} to TL	
- Ramp-up Rate	3°C/second max
Time maintained above:	
- Temperature (TL)	217°C
- Time (t _L)	60-150 seconds
Peak Temperature (T _p)	245 +0/-5°C
Time within 5°C of actual Peak Temperature (t _p)	10-30 seconds
Ramp-down Rate	6°C/second max.
Time 25°C to Peak Temperature (t _{tp})	8 minutes max.



NOTE:

All temperatures refer to topside of the package, measured on the package body surface



WARNING:

The GL865 module withstands one reflow process only.



13. Debug of the GE910 in production

To test and debug the mounting of the GE910, we strongly recommend to foreseen test pads on the host PCB, in order to check the connection between the GE910 itself and the application and to test the performance of the module connecting it with an external computer. Depending by the customer application, these pads include, but are not limited to the following signals:

- TXD
- RXD
- ON/OFF*
- HW SHUTDOWN*
- GND
- VBATT
- TX_AUX
- RX_AUX
- PWRMON



14. Packing system

14.1. Packing on tray

The GE910 modules are packaged on trays of **20** pieces each. These trays can be used in SMT processes for pick & place handling.

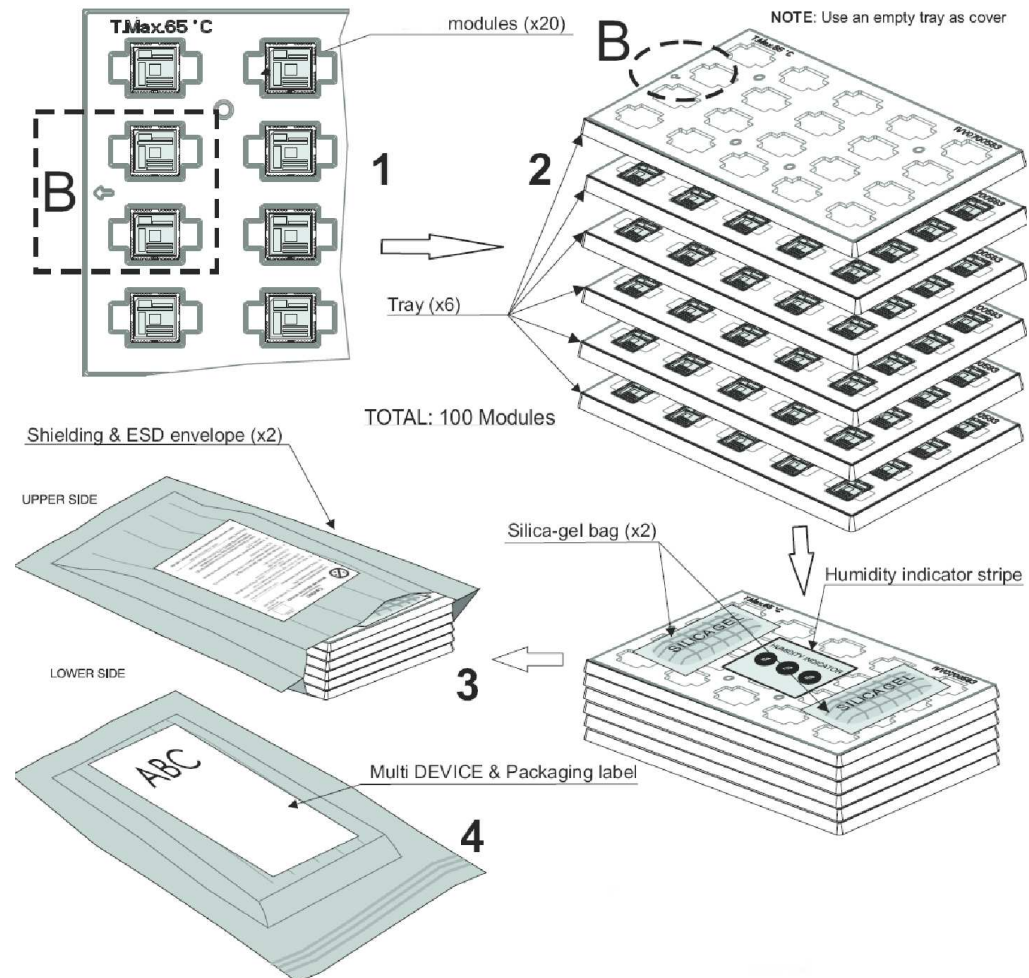

14.2. Moisture sensibility

The level of moisture sensibility of the Product is “3”, according with standard IPC/JEDEC J-STD-020, take care of all the relative requirements for using this kind of components.

Moreover, the customer has to take care of the following conditions:

- a) The shelf life of the Product inside of the dry bag must be 12 months from the bag seal date, when stored in a non-condensing atmospheric environment of $<40^{\circ}\text{C}$ / 90% RH
- b) Environmental condition during the production: $\leq 30^{\circ}\text{C}$ / 60% RH according to IPC/JEDEC J-STD-033A paragraph 5
- c) The maximum time between the opening of the sealed bag and the reflow process must be 168 hours if condition b) “IPC/JEDEC J-STD-033A paragraph 5.2” is respected
- d) Baking is required if conditions b) or c) are not respected
- e) Baking is required if the humidity indicator inside the bag indicates 10% RH or more



15. Conformity Assessment Issues

European Union - Directive 1999/5/EC

The GE910-QUAD module has been evaluated against the essential requirements of the 1999/5/EC Directive.

Bulgarian	С настоящето Telit Communications S.p.A. декларира, че Quad Band GSM/GPRS module отговаря на съществените изисквания и другите приложими изисквания на Директива 1999/5/EC.
Czech	Telit Communications S.p.A. tímto prohlašuje, že tento Quad Band GSM/GPRS module je ve shodě se základními požadavky a dalšími příslušnými ustanoveními směrnice 1999/5/ES.
Danish	Undertegnede Telit Communications S.p.A. erklærer herved, at følgende udstyr Quad Band GSM/GPRS module overholder de væsentlige krav og øvrige relevante krav i direktiv 1999/5/EF.
Dutch	Hierbij verklaart Telit Communications S.p.A. dat het toestel Quad Band GSM/GPRS module in overeenstemming is met de essentiële eisen en de andere relevante bepalingen van richtlijn 1999/5/EG.
English	Hereby, Telit Communications S.p.A., declares that this Quad Band GSM/GPRS module is in compliance with the essential requirements and other relevant provisions of Directive 1999/5/EC.
Estonian	Käesolevaga kinnitab Telit Communications S.p.A. seadme Quad Band GSM/GPRS module vastavust direktiivi 1999/5/EÜ põhinõuetele ja nimetatud direktiivist tulenevatele teistele asjakohastele sätetele.
German	Hiermit erklärt Telit Communications S.p.A., dass sich das Gerät Quad Band GSM/GPRS module in Übereinstimmung mit den grundlegenden Anforderungen und den übrigen einschlägigen Bestimmungen der Richtlinie 1999/5/EG befindet.
Greek	ΜΕ ΤΗΝ ΠΑΡΟΥΣΑ Telit Communications S.p.A. ΔΗΛΩΝΕΙ ΟΤΙ Quad Band GSM/GPRS module ΣΥΜΜΟΡΦΩΝΕΤΑΙ ΠΡΟΣ ΤΙΣ ΟΥΣΙΩΔΕΙΣ ΑΠΑΙΤΗΣΕΙΣ ΚΑΙ ΤΙΣ ΛΟΙΠΕΣ ΣΧΕΤΙΚΕΣ ΔΙΑΤΑΞΕΙΣ ΤΗΣ ΟΔΗΓΙΑΣ 1999/5/EK.
Hungarian	Alulírott, Telit Communications S.p.A. nyilatkozom, hogy a Quad Band GSM/GPRS module megfelel a vonatkozó alapvető követelményeknek és az 1999/5/EC irányelv egyéb előírásainak.
Finnish	Telit Communications S.p.A. vakuuttaa täten että Quad Band GSM/GPRS module tyyppinen laite on direktiivin 1999/5/EY oleellisten vaatimusten ja sitä koskevien direktiivin muiden ehtojen mukainen.
French	Par la présente Telit Communications S.p.A. déclare que l'appareil Quad Band GSM/GPRS module est conforme aux exigences essentielles et aux autres dispositions pertinentes de la directive 1999/5/CE.
Icelandic	Hér með lýsir Telit Communications S.p.A. yfir því að Quad Band GSM/GPRS module er í samræmi við grunnkröfur og aðrar kröfur, sem gerðar eru í tilskipun 1999/5/EC
Italian	Con la presente Telit Communications S.p.A. dichiara che questo Quad Band GSM/GPRS module è conforme ai requisiti essenziali ed alle altre disposizioni pertinenti stabilite dalla direttiva 1999/5/CE.
Latvian	Ar šo Telit Communications S.p.A. deklarē, ka Quad Band GSM/GPRS module atbilst Direktīvas 1999/5/EK būtiskajām prasībām un citiem ar to saistītajiem noteikumiem.



Lithuanian	Šiuo Telit Communications S.p.A. deklaruoja, kad šis Quad Band GSM/GPRS module atitinka esminius reikalavimus ir kitas 1999/5/EB Direktyvos nuostatas.
Maltese	Hawnhekk, Telit Communications S.p.A., jiddikjara li dan Quad Band GSM/GPRS module jikkonforma mal-htigijiet essenzjali u ma provvedimenti ohrajn relevanti li hemm fid-Dirrettiva 1999/5/EC.
Norwegian	Telit Communications S.p.A. erklærer herved at utstyret Quad Band GSM/GPRS module er i samsvar med de grunnleggende krav og øvrige relevante krav i direktiv 1999/5/EF.
Polish	Niniejszym Telit Communications S.p.A. oświadcza, że Quad Band GSM/GPRS module jest zgodny z zasadniczymi wymogami oraz pozostałymi stosownymi postanowieniami Dyrektywy 1999/5/EC
Portuguese	Telit Communications S.p.A. declara que este Quad Band GSM/GPRS module está conforme com os requisitos essenciais e outras disposições da Directiva 1999/5/CE.
Slovak	Telit Communications S.p.A. týmto vyhlasuje, že Quad Band GSM/GPRS module spĺňa základné požiadavky a všetky príslušné ustanovenia Smernice 1999/5/ES.
Slovenian	Telit Communications S.p.A. izjavlja, da je ta Quad Band GSM/GPRS module v skladu z bistvenimi zahtevami in ostalimi relevantnimi določili direktive 1999/5/ES.
Spanish	Por medio de la presente Telit Communications S.p.A. declara que el Quad Band GSM/GPRS module cumple con los requisitos esenciales y cualesquiera otras disposiciones aplicables o exigibles de la Directiva 1999/5/CE.
Swedish	Härmed intygar Telit Communications S.p.A. att denna Quad Band GSM/GPRS module står i överensstämmelse med de väsentliga egenskapskrav och övriga relevanta bestämmelser som framgår av direktiv 1999/5/EG.

In order to satisfy the essential requirements of 1999/5/EC Directive, GE910-QUAD module is compliant with the following standards:

RF spectrum use (R&TTE art. 3.2)	EN 301 511 V9.0.2
EMC (R&TTE art. 3.1b)	EN 301 489-1 V1.9.2 EN 301 489-7 V1.3.1
Health & Safety (R&TTE art. 3.1a)	EN 60950-1:2006 + A11:2009 + A1:2010 + A12:2011



The conformity assessment procedure referred to in Article 10 and detailed in Annex IV of Directive 1999/5/EC has been followed with the involvement of the following Notified Body:

AT4 wireless, S.A.
Parque Tecnológico de Andalucía
C/ Severo Ochoa 2
29590 Campanillas – Málaga
SPAIN
Notified Body No: 1909

Thus, the following marking is included in the product:



The full declaration is available on the following address:

<http://www.telit.com/>

There is no restriction for the commercialisation of the GE910-QUAD module in all the countries of the European Union.

Final product integrating this module must be assessed against essential requirements of the 1999/5/EC (R&TTE) Directive. It should be noted that assessment does not necessarily lead to testing. Telit Communications S.p.A. recommends carrying out the following assessments:

RF spectrum use (R&TTE art. 3.2)	It will depend on the antenna used on the final product.
EMC (R&TTE art. 3.1b)	Testing
Health & Safety (R&TTE art. 3.1a)	Testing



FCC/IC Regulatory notices

Modification statement

Telit has not approved any changes or modifications to this device by the user. Any changes or modifications could void the user's authority to operate the equipment.

Telit n'approuve aucune modification apportée à l'appareil par l'utilisateur, quelle qu'en soit la nature. Tout changement ou modification peuvent annuler le droit d'utilisation de l'appareil par l'utilisateur.

Interference statement

This device complies with Part 15 of the FCC Rules and Industry Canada licence-exempt RSS standard(s). Operation is subject to the following two conditions: (1) this device may not cause interference, and (2) this device must accept any interference, including interference that may cause undesired operation of the device.

Le présent appareil est conforme aux CNR d'Industrie Canada applicables aux appareils radio exempts de licence. L'exploitation est autorisée aux deux conditions suivantes : (1) l'appareil ne doit pas produire de brouillage, et (2) l'utilisateur de l'appareil doit accepter tout brouillage radioélectrique subi, même si le brouillage est susceptible d'en compromettre le fonctionnement.

Wireless notice

This equipment complies with FCC and IC radiation exposure limits set forth for an uncontrolled environment. The antenna should be installed and operated with minimum distance of 20 cm between the radiator and your body. Antenna gain must be below:

Frequency band	Antenna gain
GSM 850	8.32 dBi
PCS 1900	3.34 dBi

This transmitter must not be co-located or operating in conjunction with any other antenna or transmitter.

Cet appareil est conforme aux limites d'exposition aux rayonnements de la IC pour un environnement non contrôlé. L'antenne doit être installé de façon à garder une distance minimale de 20 centimètres entre la source de rayonnements et votre corps. Gain de l'antenne doit être ci-dessous:

Bande de fréquence	Gain de l'antenne
GSM 850	8.32 dBi
PCS 1900	3.34 dBi

L'émetteur ne doit pas être colocalisé ni fonctionner conjointement avec à autre antenne ou autre émetteur.



FCC Class B digital device notice

This equipment has been tested and found to comply with the limits for a Class B digital device, pursuant to part 15 of the FCC Rules. These limits are designed to provide reasonable protection against harmful interference in a residential installation. This equipment generates, uses and can radiate radio frequency energy and, if not installed and used in accordance with the instructions, may cause harmful interference to radio communications. However, there is no guarantee that interference will not occur in a particular installation. If this equipment does cause harmful interference to radio or television reception, which can be determined by turning the equipment off and on, the user is encouraged to try to correct the interference by one or more of the following measures:

- Reorient or relocate the receiving antenna.
- Increase the separation between the equipment and receiver.
- Connect the equipment into an outlet on a circuit different from that to which the receiver is connected.
- Consult the dealer or an experienced radio/TV technician for help.



16. SAFETY RECOMMENDATIONS

READ CAREFULLY

Be sure the use of this product is allowed in the country and in the environment required. The use of this product may be dangerous and has to be avoided in the following areas:

- Where it can interfere with other electronic devices in environments such as hospitals, airports, aircrafts, etc
- Where there is risk of explosion such as gasoline stations, oil refineries, etc

It is responsibility of the user to enforce the country regulation and the specific environment regulation.

Do not disassemble the product; any mark of tampering will compromise the warranty validity. We recommend following the instructions of the hardware user guides for a correct wiring of the product. The product has to be supplied with a stabilized voltage source and the wiring has to be conforming to the security and fire prevention regulations.

The product has to be handled with care, avoiding any contact with the pins because electrostatic discharges may damage the product itself. Same cautions have to be taken for the SIM, checking carefully the instruction for its use. Do not insert or remove the SIM when the product is in power saving mode.

The system integrator is responsible of the functioning of the final product; therefore, care has to be taken to the external components of the module, as well as of any project or installation issue, because the risk of disturbing the GSM network or external devices or having impact on the security. Should there be any doubt, please refer to the technical documentation and the regulations in force.

Every module has to be equipped with a proper antenna with specific characteristics. The antenna has to be installed with care in order to avoid any interference with other electronic devices and has to guarantee a minimum distance from the body (20 cm). In case of this requirement cannot be satisfied, the system integrator has to assess the final product against the SAR regulation.

The European Community provides some Directives for the electronic equipments introduced on the market. All the relevant information's are available on the European Community website:

<http://ec.europa.eu/enterprise/sectors/rtte/documents/>

The text of the Directive 99/05 regarding telecommunication equipments is available, while the applicable Directives (Low Voltage and EMC) are available at:

<http://ec.europa.eu/enterprise/sectors/electrical>



17. Document History

Revision	Date	Changes
Rev.0	2011-11-11	First Release Rev.0 Preliminary 1
Rev.1	2012-02-27	First Release Rev.1
Rev.2	2012-06-07	Added chapter 11.7 ADC Converter – renaming pin RESET# in HW SHUTDOWN* Chapter 5.2 Power consumption
Rev.3	2012-06-20	Added chapter 12.3 inhibit area around the RF pins
Rev.4	2012-06-25	Updated chapter 15 Conformity Assessment Issues

