

GE864 and GC864 Product Description

80273ST10008a Rev. 17 - 2009-12-01



Telit GE864 and GC864 Product Description
80273ST10008a Rev. 17-2009-12-01

APPLICABILITY TABLE

The information contained in this document is referred to the following products:

<p>GSM GPRS</p> <p>GE864-QUAD Embedded</p> <p>GE864-PY Embedded</p>		<p>GSM GPRS</p> <p>GC864-QUAD Compact</p> <p>GC864-PY Compact</p>	
---	---	---	---



Telit GE864 and GC864 Product Description
80273ST10008a Rev. 17-2009-12-01

DISCLAIMER

The information contained in this document is the proprietary information of Telit Communications S.p.A. and its affiliates ("TELIT").

The contents are confidential and any disclosure to persons other than the officers, employees, agents or subcontractors of the owner or licensee of this document, without the prior written consent of Telit, is strictly prohibited.

Telit makes every effort to ensure the quality of the information it makes available. Notwithstanding the foregoing, Telit does not make any warranty as to the information contained herein, and does not accept any liability for any injury, loss or damage of any kind incurred by use of or reliance upon the information.

Telit disclaims any and all responsibility for the application of the devices characterized in this document, and notes that the application of the device must comply with the safety standards of the applicable country, and where applicable, with the relevant wiring rules.

Telit reserves the right to make modifications, additions and deletions to this document due to typographical errors, inaccurate information, or improvements to programs and/or equipment at any time and without notice.

Such changes will, nevertheless be incorporated into new editions of this document.

Copyright: Transmittal, reproduction, dissemination and/or editing of this document as well as utilization of its contents and communication thereof to others without express authorization are prohibited. Offenders will be held liable for payment of damages. All rights are reserved.

Copyright © Telit Communications S.p.A. 2009.



Contents

1.	INTRODUCTION	7
1.1.	AUDIENCE	7
1.2.	CONTACT INFORMATION, SUPPORT	7
1.3.	DOCUMENT ORGANIZATION	7
1.4.	TEXT CONVENTIONS	8
1.5.	RELATED DOCUMENTS	9
1.6.	DOCUMENT HISTORY	9
2.	OVERVIEW	13
3.	GENERAL PRODUCT DESCRIPTION	15
3.1.	DIMENSIONS	15
3.1.1.	<i>GE864-QUAD/PY</i>	15
3.1.2.	<i>GC864-QUAD/PY with and without SIM Holder</i>	16
3.2.	WEIGHT	17
3.3.	ENVIRONMENTAL REQUIREMENTS	17
3.3.1.	<i>Temperature range</i>	17
3.3.2.	<i>Vibration Test (non functional)</i>	17
3.3.3.	<i>RoHS compliance</i>	18
3.4.	OPERATING FREQUENCY	18
3.5.	TRANSMITTER OUTPUT POWER	18
3.6.	REFERENCE SENSITIVITY	19
3.7.	ANTENNA	20
3.7.1.	<i>GC864 QUAD/PY RF antenna connector</i>	20
3.8.	SUPPLY VOLTAGE	20
3.9.	POWER CONSUMPTION	21
3.10.	EMBODIED BATTERY CHARGER	21
3.11.	USER INTERFACE	22
3.11.1.	<i>Speech Coding</i>	22
3.11.2.	<i>SIM Reader</i>	22
3.11.3.	<i>SMS</i>	22
3.11.4.	<i>Real Time Clock and Alarm</i>	23
3.11.5.	<i>Data/fax transmission</i>	23
3.11.6.	<i>Local security management</i>	23
3.11.7.	<i>Call control</i>	23
3.11.8.	<i>Phonebook</i>	23
3.11.9.	<i>Characters management</i>	23
3.11.10.	<i>SIM related functions</i>	24
3.11.11.	<i>Call status indication</i>	24
3.11.12.	<i>Automatic answer (Voice, Data or FAX)</i>	24
3.11.13.	<i>Supplementary services (SS)</i>	24
3.11.14.	<i>Acoustic signaling</i>	25



Telit GE864 and GC864 Product Description
80273ST10008a Rev. 17-2009-12-01

- 3.11.15. *Buzzer output*.....25
- 3.11.16. *RF Transmission Monitor*.....25
- 3.12. LOGIC LEVEL SPECIFICATIONS25
 - 3.12.1. *Reset signal*.....26
- 3.13. AUDIO LEVELS SPECIFICATIONS.....26
- 3.14. CONVERTERS27
 - 3.14.1. *ADC Converter*.....27
 - 3.14.2. *DAC Converter*.....27
- 3.15. MOUNTING THE GE864 ON YOUR BOARD28
 - 3.15.1. *General*.....28
- 3.16. MOUNTING THE GC864 ON YOUR BOARD28
- 4. PACKING SYSTEM 29
 - 4.1. GE864-QUAD/PY PACKAGE.....29
 - 4.1.1. *GE864-QUAD/PY Tray package*.....29
 - 4.1.2. *GE864-QUAD/PY Reel package*.....30
 - 4.2. GC864 QUAD/PY PACKAGE31
- 5. EVALUATION KIT 32
- 6. SOFTWARE FEATURES 34
 - 6.1. EASY GPRS EXTENSION.....34
 - 6.1.1. *Overview*.....34
 - 6.1.2. *Easy GPRS definition*.....35
 - 6.2. MULTISOCKET36
 - 6.3. JAMMED DETECT & REPORT EXTENSION.....37
 - 6.3.1. *Overview*.....37
 - 6.4. CMUX.....37
 - 6.4.1. *Product architecture*.....38
 - 6.4.2. *Implementation feature and limitation*.....38
 - 6.5. EASY SCRIPT EXTENSION - PYTHON INTERPRETER39
 - 6.5.1. *Overview*.....39
 - 6.5.2. *Python 1.5.2+ Copyright Notice*.....41
 - 6.5.3. *Python implementation description*.....42
 - 6.5.4. *Python core supported features*.....44
 - 6.5.5. *Python Build-in Custom Modules*.....45
 - 6.6. SAP: SIM ACCESS PROFILE45
 - 6.6.1. *Product architecture*.....45
 - 6.6.2. *Implementation features*.....46
 - 6.6.3. *Remote SIM Message Command Description*.....46
 - 6.7. PFM (PREMIUM FOTA MANAGEMENT)47
 - 6.7.1. *FOTA (Firmware Over-The-Air)*.....47
- 7. AT COMMANDS..... 48
 - HAYES STANDARD AT COMMAND SET, IN ORDER TO MAINTAIN THE COMPATIBILITY WITH EXISTING SW PROGRAMS.....48
- 8. DRIVERS 49



Telit GE864 and GC864 Product Description
80273ST10008a Rev. 17-2009-12-01

- 9. CONFORMITY ASSESSMENT ISSUES..... 50
 - 9.1. GE864-QUAD CONFORMITY ASSESSMENT52
 - 9.2. GE864-PY CONFORMITY ASSESSMENT54
 - 9.3. GE864-QUAD/PY: RoHS CERTIFICATE56
 - 9.4. GC864-QUAD: CONFORMITY ASSESSMENT57
 - 9.5. GC864-PY: CONFORMITY ASSESSMENT59
 - 9.6. GC864-QUAD/PY: RoHS CERTIFICATE.....61
 - 9.7. GE864-QUAD/PY: FCC EQUIPMENT AUTHORIZATION62
 - 9.8. GC864-QUAD/PY: FCC EQUIPMENT AUTHORIZATION63
 - 9.9. GE864-QUAD/PY: IC EQUIPMENT AUTHORIZATION64
 - 9.10. GC864-QUAD/PY: IC EQUIPMENT AUTHORIZATION65
- 10. SAFETY RECOMMENDATIONS 66
- 11. LIST OF ACRONYMS..... 68



1. Introduction

The information presented in this document is believed to be accurate and reliable. However, no responsibility is assumed by Telit Communications S.p.A. for its use, nor any infringement of patents or other rights of third parties which may result from its use. No license is granted by implication or otherwise under any patent rights of Telit Communications S.p.A. other than for circuitry embodied in Telit products. This document is subject to change without notice.

1.1. Audience

This document is intended for customers who are evaluating one or more products in the applicability table.

1.2. Contact Information, Support

For general contact, technical support, to report documentation errors and to order manuals, contact Telit Technical Support Center (TTSC) at:

TS-EMEA@telit.com
TS-NORTHAMERICA@telit.com
TS-LATINAMERICA@telit.com
TS-APAC@telit.com

Alternatively, use:

<http://www.telit.com/en/products/technical-support-center/contact.php>

For detailed information about where you can buy the Telit modules or for recommendations on accessories and components visit:

<http://www.telit.com>

To register for product news and announcements or for product questions contact Telit's Technical Support Center (TTSC).

Our aim is to make this guide as helpful as possible. Keep us informed of your comments and suggestions for improvements.

Telit appreciates feedback from the users of our information.

1.3. Document Organization

This document contains the following chapters:



Telit GE864 and GC864 Product Description

80273ST10008a Rev. 17-2009-12-01

[“Chapter 1: “Introduction”](#) provides a scope for this document, target audience, contact and support information, and text conventions.

[“Chapter 2: “Overview”](#) gives a brief overview about the spectrum of features and possible application environments for the GC864 product family.

[“Chapter 3: “General Product Specification”](#) provides a broad description of the modules as far as size, PCB characteristics and technical specifications.

[“Chapter 4: “Packing System”](#) provides a brief description of packing system of GE/GC864.

[“Chapter 5: “Evaluation Kit”](#) provides a brief description of the Telit Evaluation Kit (EVK2) as far as the applicable modules are concerned.

[“Chapter 6: “Software Features”](#) describes in details concepts involved in the software equipped on the modules.

[“Chapter 7: “AT Commands”](#) provides specification of the AT commands supported by the modules.

[“Chapter 8: “Drivers”](#) provides the available drivers for the modules.

[“Chapter 9: “Conformity Assessment”](#) provides specification assessment certificates of the modules.

[“Chapter 10: “Safety Recommendations”](#) provides recommendation for correct usage of the modules.

[“Chapter 11: “List of acronyms”](#) provides explanation of acronyms used in the present document.

1.4. Text Conventions



Danger – This information MUST be followed or catastrophic equipment failure or bodily injury may occur.



Telit GE864 and GC864 Product Description
80273ST10008a Rev. 17-2009-12-01



Caution or Warning – Alerts the user to important points about integrating the module, if these points are not followed, the module and end user equipment may fail or malfunction.



Tip or Information – Provides advice and suggestions that may be useful when integrating the module.

All dates are in ISO 8601 format, i.e. YYYY-MM-DD.

1.5. Related Documents

The following is a list of applicable documents downloadable from the Download Zone section of Telit website <http://www.telit.com>

- GC864 Hardware User Guide, 1v0300733;
- GE864 Hardware User Guide, 1v0300694;
- GE864-QUAD vs QUAD Automotive Application Note, 80000nt10024a;
- Easy GPRS User Guide, 80000ST10028;
- Easy Script in Python, 80000ST10020a;
- CMUX User Guide, 30268ST10299a;
- SIM Access Profile User Guide, 8000ST10029;
- AT Commands Reference Guide, 80000ST10025a;
- Telit modules SW User Guide 1v0300784;
- Telit EVK2 User Guide, 1v0300704.

1.6. Document History

Revision	Date	Changes
DRAFT #0		Draft for comments



Telit GE864 and GC864 Product Description
80273ST10008a Rev. 17-2009-12-01

		<p>5.4 SAP: new paragraph</p> <p>6 AT commands: added AT commands (CMUX, SAP and others: see rows in yellow)</p> <p>7.2 GE864-PY Conformity assessment added</p> <p>7.3 GC864-QUAD Conformity assessment added</p> <p>7.4 GC864-PY Conformity assessment added</p> <p>7.5 GE864-QUAD/PY: FCC Equipment Authorization</p> <p>7.6 GC864-QUAD/PY: FCC Equipment Authorization</p> <p>7.7 GE864-QUAD/PY: IC Equipment Authorization</p> <p>7.8 GC864-QUAD/PY: IC Equipment Authorization</p>
ISSUE #7	2006-10-23	<p>Weight: changed weight value for GC864</p> <p>2.7 Antenna: changed bandwidth values</p> <p>Power Consumption: updated operating current in GPRS</p> <p>2.16 Audio levels specifications: updated microphone and speaker characteristics</p> <p>2.19.3 GC864 pins allocation: pin 49 PWRMON changed in output (page 33)</p> <p>2.22.1 GE864 orientation on the tray: updated module image</p> <p>5.3 Easy Scrip- Extension - Python Interpreter: updated schema</p> <p>6 AT commands: cancelled AT commands table</p> <p>7.3 GE864-QUAD/PY: RoHS certificate</p> <p>7.6 GC864-QUAD/PY: RoHS certificate</p>
ISSUE #8	2007-02-08	<p>Power Consumption: updated operating current in GSM</p> <p>general review of the document</p> <p>complete revision of the document: removed camera, and come paragraphs transferred to the HW or SW User Guide</p>
ISSUE #9	2007-11-12	<p>-new disclaimer</p> <p>-Updated temperature range values</p> <p>-Added Python's new features</p> <p>-Added Multisocket paragraph</p>
ISSUE #10	2008-01-15	Added CE mark
ISSUE #11	2008-03-11	Updated temperature specification
ISSUE #12	2008-05-16	Added new GC864-QUAD variant with SIM holder on the board
ISSUE #13	2008-07-16	Updated temperature range specification
ISSUE #14	2008-09-18	<p>Updated applicability list</p> <p>Updated temperature range specification</p> <p>Updated RoHS compliance certification</p> <p>Added FOTA service description</p>
ISSUE #15	2009-03-24	<p>New disclaimer</p> <p>Updated idle current consumption</p> <p>§2.17 updated image with new unified label</p> <p>Updated supported module character set</p> <p>Updated firmware over the air service name</p>



Telit GE864 and GC864 Product Description
80273ST10008a Rev. 17-2009-12-01

ISSUE #16	2009-05-25	Applied new layout Updated ARFCN channel identification Updated Packing system Updated Assessment chapter
ISSUE #17	2009-12-01	Deleted GE864-QUAD Antenna's description and features. Updated power consumption in idle mode Updated GE864's RoHS compliance declaration



2. Overview

The **Telit GE864** and **GC864 modules** are small, lightweight, low power consumption and RoHS compliant devices that allow digital communication services wherever a GSM 850, 900, DCS 1800 or PCS 1900 network is present.

The **GE864** is a low cost connector-less top-notch solution for medium to high quantity projects.

The **GC864** is provided with an 80-pin Molex board-to-board connector and a 50 Ohm Murata RF connector. It has the same performance as GE864.

The **GC864-QUAD with SIM holder** has an integrated SIM holder on the board and identical technical characteristics as the classic **GC864-QUAD**.

The **GE864-PY** and **GC864-PY** models integrate the "**EASY SCRIPT**" on top of all other features of the **GE864-QUAD** and **GC864-QUAD**. Python is an engine script interpreter, allowing self-controlled operations. With the **EASY SCRIPT** feature the **GE864-PY** and **GC864-PY** become a finite product, they just need your script to be run.

All **GE864** and **GC864** models includes features like GPRS Class 10, Voice, Circuit Switched Data transfer, Fax, Phonebook and SMS support, 'EASY GPRS' embedded TCP/IP stack and battery charging capabilities.

The **GE864** and **GC864** are specifically designed and developed by **Telit** for OEM usage and dedicated to portable data, voice and telemetric applications such as:

- **Telemetry and Telecontrol (SCADA applications);**
- **Security systems;**
- **Automated Meter Reading (AMR);**
- **Vending machines;**
- **POS terminals;**
- **PDA's and Mobile Computing;**
- **Phones and Payphones;**
- **Automotive and Fleet Management applications;**
- **Battery powered applications needing a battery charger;**
- **Return channel for digital broadcasting;**
- **Applications, where the external application processor can be replaced by the PYTHON engine provided by the GE864-PY or GC864-PY.**

All models support the following functionalities



Telit GE864 and GC864 Product Description
80273ST10008a Rev. 17-2009-12-01

- EASY GPRS (AT driven embedded TCP/IP protocol stack);
- EASY SCAN (full GSM frequency scanning);
- JAMMING DETECT & REPORT (detect the presence of disturbing devices);
- CMUX;
- SAP (SIM Access Profile);
- Multisocket;

From the interface point of view, the **GE864** and **GC864** provide the following:

- Full RS232 UART, CMOS level (ASC0) interface for AT commands:
 - Autobauding from 1.2 up to 115.2 Kbps;
 - Fixed baud rate from 300 bit/s up to 115.2 Kbps;
- Two wires RS232, CMOS level (ASC1) for PYTHON debug;
- SIM card interface, 1.8 / 3 volts with auto-detection, hot insertion;
- 21 x GPIO ports (max);
- 3 x A/D converters;
- 1 x D/A converter;
- 1 x buzzer output;
- 1 x vibrator motor driver output;
- 1 x single led supply output.

In order to meet the competitive OEM and vertical market stringent requirements, Telit supports its customers with a dedicated Support Policy with:

Telit Evaluation Kit EVK2 to help you develop your application;
A Website with all updated information available;
A high level specialized technical support to assist you in your development.

For more updated information concerning the product roadmaps and availability, technical characteristics, commercial and other issues, please check on the Telit website www.telit.com > Products > Modules.



NOTICE:

Some of the performances of the **Telit modules** depend on the SW version installed on the module itself. The **Telit modules** SW group is continuously working in order to add new features and improve the overall performances. The **Telit modules** are easily upgradeable by the developer using the **Telit Flash Programmer**. Furthermore, all the **Telit modules** have the conformity assessment against R&TTE.



3. General Product Description

3.1. Dimensions

3.1.1. GE864-QUAD/PY

The Telit GE864-QUAD-PY module overall dimensions are:

Length: 30 mm
Width: 30 mm
Thickness: 2.8 mm

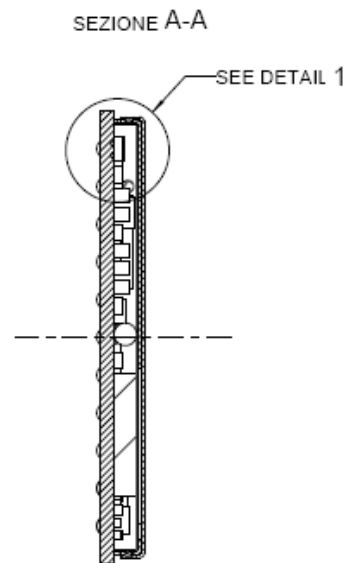
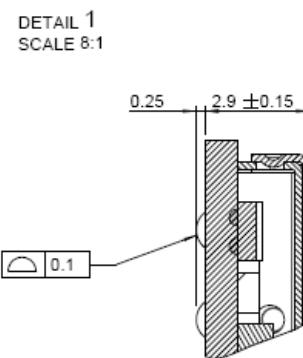
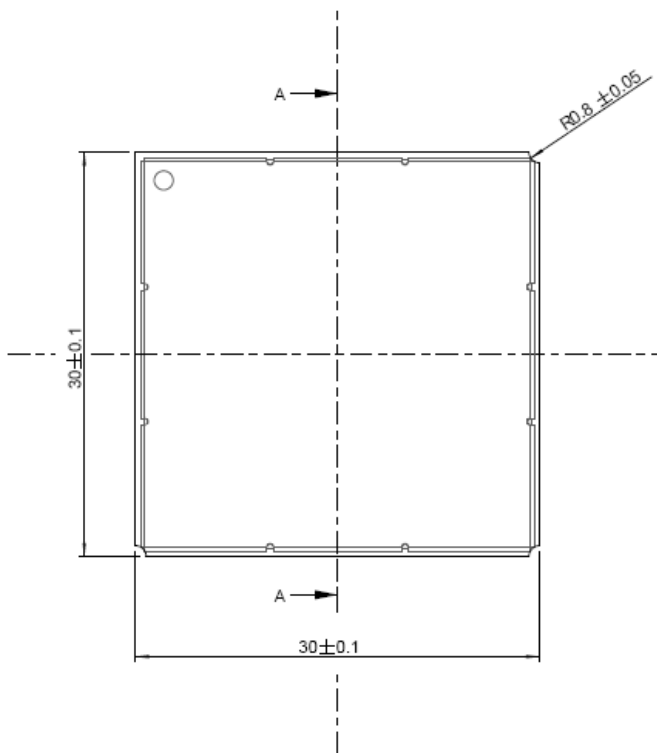

Telit GE864 and GC864 Product Description
80273ST10008a Rev. 17-2009-12-01

3.1.2. GC864-QUAD/PY with and without SIM Holder

The Telit GC864 module overall dimensions are:

Length: 36.2 mm
Width: 30 mm
Thickness: 3.2 mm

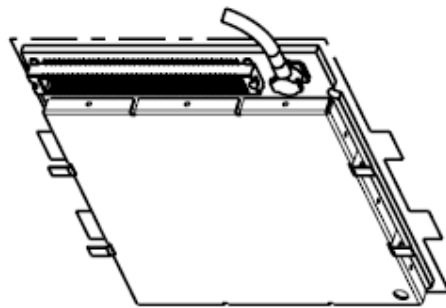
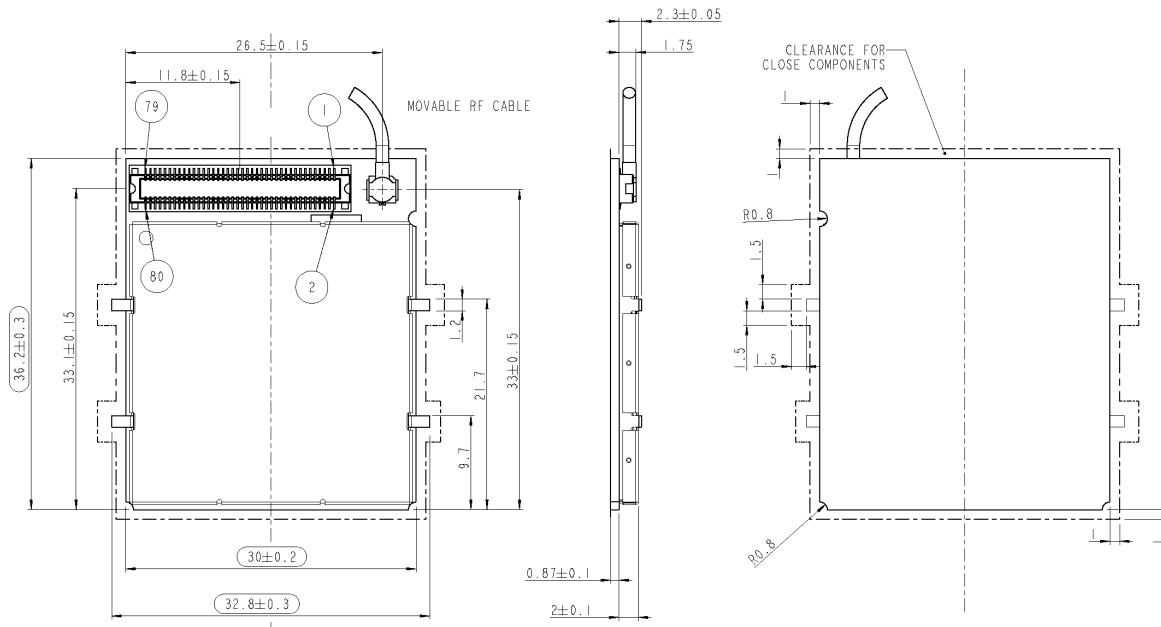

3.2. Weight

weight	
GE864-QUAD/PY	6 gr
GC864 -QUAD/PY	6,1 gr

3.3. Environmental requirements

The Telit **GE864** and **GC864** modules are compliant with the applicable ETSI reference documentation GSM 05.05 Release1998.

3.3.1. Temperature range

	GE864-QUAD/PY	GC864-QUAD/PY	Note
Operating Temperature Range	-20°C ÷ +55°C	-20°C ÷ +55°C	The module is fully functional(*) in all the temperature range, and it fully meets the ETSI specifications.
	-40°C ÷ +85°C	-40°C ÷ +85°C	The module is fully functional (*) in all the temperature range. Temperatures outside the range -20°C ÷ +55°C, might slightly deviate from ETSI specifications.
Storage and Non Operating Temperature Range	-40°C ÷ +85°C	-40°C ÷ +85°C	

(*) Functional: the module is able to make and receive voice calls, data calls, SMS and make GPRS traffic.

3.3.2. Vibration Test (non functional)

10 ÷ 12Hz ASD = 1.92m 2 /s 3
12 ÷ 150Hz -3dB/oct

These values are valid for the GE864-QUAD/PY and GC864-QUAD/PY modules only.



3.3.3. RoHS compliance

As a part of Telit corporate policy regarding environmental protection, the **GE864** and **GC864** comply with the RoHS (Restriction of Hazardous Substances) directive of the European Union (EU Directive 2002/95/EG).

3.4. Operating Frequency

The operating frequencies in GSM, DCS, PCS modes are conform to the GSM specifications.

Mode	Freq. TX (MHz)	Freq. RX (MHz)	Channels (ARFC)	TX – RX offset
GSM-850	824.2÷848.8	869.2÷893.8	128 ÷ 251	45 MHz
E-GSM-900	890.0 – 914.8	935.0 – 959.8	0 – 124	45 MHz
	880.2 – 889.8	925.2 – 934.8	975 – 1023	45 MHz
DCS-1800	1710.2 – 1784.8	1805.2 – 1879.8	512 – 885	95 MHz
PCS-1900	1850.2 – 1909.8	1930.2 – 1989.8	512 – 810	80 MHz

3.5. Transmitter output power

GSM-850/900

The **Telit GE864** and **GC864** transceiver modules, in GSM-850/900 operating mode, are **class 4** in accordance with the specifications which determine the nominal 2W peak RF power (+33dBm) on 50 Ohm.

DCS-1800/PCS-1900

The **Telit GE864** and **GC864** transceiver modules, in DCS-1800/PCS-1900 operating mode, are **class 1** in accordance with the specifications which determine the nominal 1W peak RF power (+30dBm) on 50 Ohm.



3.6. Reference sensitivity

GSM-850/900

The sensitivity of the **Telit GE864** and **GC864** modules, according to the specifications for the class 4 GSM 850/900 portable terminals, are **-107 dBm (50 Ohm)** typical in normal operating conditions.

DCS-1800/PCS-1900

The sensitivity of the **Telit GE864** and **GC864** module, according to the specifications for the class 1 portable terminals DCS-1800/PCS 1900, are **-106 dBm (50 Ohm)** typical in normal operating conditions.



3.7. Antenna

The antenna that the customer chooses to use should fulfill the following requirements:

Frequency range	Depending by frequency band(s) provided by the network operator, the customer shall use the most suitable antenna for that/those band(s)
Bandwidth	80 MHz in EGSM 900, 70 MHz if GSM 850, 170 MHz in DCS, 140 MHz PCS band

For further information, please refer to the GE864 and GC864 Hardware User Guide.

3.7.1. GC864 QUAD/PY RF antenna connector

The **GC864** module is equipped with a 50 Ohm RF connector from Murata, GSC type P/N **MM9329-2700B**. The suitable counterpart is Murata **MXTK92** Type or **MXTK88** Type.

Moreover, the **GC864** has the antenna pads on the back side of the PCB. This allows the manual soldering of the coaxial cable directly on the back side of the PCB. However, the soldering is not an advisable solution for a reliable connection of the antenna.

3.8. Supply voltage

The external power supply must be connected to VBATT signal and must fulfill the following requirements:

POWER SUPPLY		
	SW rel. 7.02.xx4 or older	SW rel. 7.02.xx5 or newer
Nominal Supply Voltage	3.8 V	3.8 V
Max Supply Voltage	4.2 V	4.5 V
Supply voltage range	3.4 V – 4.2 V	3.22 V – 4.5 V





NOTICE:

Operating voltage range must never be exceeded; care must be taken in order to fulfill min/max voltage requirements.

3.9. Power consumption

The typical current consumption of the **Telit GE864** and **GC864** are:

Power off current (typical)	< 26 μ A;
Stand-by current (GSM Idle – power saving)	< 2.5 @ DRX=9 (AT+CFUN=5)
Operating current in voice channel	<200 mA @ worst network conditions
Operating current in GPRS class 10	< 370 mA @ worst network conditions

3.10. Embodied Battery charger

The battery charger is suited for 3.7V Li-Ion rechargeable battery (suggested capacity 500-1000mAh). The Charger needs only a CURRENT LIMITED power source input and charges the battery directly through VBATT connector pins.

Battery charger input pin	CHARGE
Battery pins	VBATT, GND
Battery charger input voltage min	5.0 V
Battery charger input voltage typ	5.5 V
Battery charger input voltage max	7.0 V
Battery charger input current max	400mA
Battery type	Li-Ion rechargeable



NOTICE:



Telit GE864 and GC864 Product Description
80273ST10008a Rev. 17-2009-12-01

If embodied battery charger is used, then a LOW ESR capacitor of at least 100 μ F must be mounted in parallel to VBATT pin.

When power is supplied to the CHARGE pin, a battery must always be connected to the VBATT pin of the GE864 / GC864.

3.11. User Interface

The user interface is managed by AT commands specified on the ITU-T V.250, GSM 07.07 and 07.05 specifications.

3.11.1. Speech Coding

The **GE864** and **GC864** voice codec support the following rates:

Half Rate;
Full rate;
Enhanced Full Rate;
Adaptive Multi Rate.

3.11.2. SIM Reader

The **GE864** and **GC864** modules support phase 2 GSM11.14 – SIM 1.8V and 3V ONLY with an external SIM connector. For 5V SIM operation an external level translator can be added.

3.11.3. SMS

The **GE864** and **GC864** support the following SMS types:

Mobile Terminated (MT) class 0 – 3 with signaling of new incoming SMS, SIM full, SMS read;
Mobile Originated class 0 – 3 with writing, memorize in SIM and sending;
Cell Broadcast compatible with CB DRX with signaling of new incoming SMS.



3.11.4. Real Time Clock and Alarm

The **Telit GE864** and **GC864** support the Real Time Clock and Alarm functions through AT commands, furthermore an alarm output pin (GPIO6) can be configured to indicate the alarm with a hardware line output.

Furthermore the Voltage Output of the RTC power supply is provided so that a backup capacitor can be added to increase the RTC autonomy.

3.11.5. Data/fax transmission

The Telit GE864 and GC864 support:

GPRS Class 10, MS Class B;
CSD up to 14.4 Kbps;
Fax service, Class 1 Group 3.

3.11.6. Local security management

The local security management can be done with the lock of Subscriber Identity module (SIM), and security code request at power-up.

3.11.7. Call control

The call cost control function is supported.

3.11.8. Phonebook

This function allows the storing of the telephone numbers in SIM memory. The capability depends on SIM version and embedded memory.

3.11.9. Characters management

The **Telit GE864** and **GC864** support the following character sets:

IRA (International Reference Alphabet), in TEXT and PDU mode;
UCS2;
GSM Default



3.11.10. SIM related functions

Activation and deactivation of the numbers stored in phone book FDN, © and PINs are supported. Extension at the PIN2 for the PUK2 insertion capability for lock condition is supported.

3.11.11. Call status indication

The call status indication by AT commands is supported.

3.11.12. Automatic answer (Voice, Data or FAX)

After a specified number of rings, the module will automatically answer with a beep. The user can set the number of rings by means of the command `ATS0=<n>`.

3.11.13. Supplementary services (SS)

The following supplementary services are supported:

- Call Barring;
- Call Forwarding;
- Calling Line Identification Presentation (CLIP);
- Calling Line Identification Restriction (CLIR);
- Call Waiting, other party call Waiting Indication;
- Call Hold, other party Hold / Retrieved Indication;
- Closed User Group supplementary service (CUG);
- Advice of Charge;
- Unstructured SS Mobile Originated (MO).



3.11.14. Acoustic signaling

The acoustic signaling of the **GE864** and **GC864** on the selected acoustic device are the following:

- Call waiting;
- Ringing tone;
- SMS received tone;
- Busy tone;
- Power on/off tone;
- Off Hook dial tone;
- Congestion tone;
- Connected tone;
- Call dropped;
- No service tone;
- Alarm tone.

3.11.15. Buzzer output

The General Purpose I/O pin GPIO7 can be configured to output the BUZZER output signal, with only an external MOSFET/transistor and a diode a Buzzer can be directly driven.

The ringing tone and the other signaling tones can be redirected to this Buzzer output with a specific AT command.

3.11.16. RF Transmission Monitor

As alternate function of the GPIO5, the **GE864** and **GC864** provide the RF transmission monitor. When the alternate function is activated, the pin of GPIO5 changes to HIGH every time the module transmits an RF signal and remains HIGH for the duration of the transmission sequence, i.e. it does not change with every GSM signal burst.

3.12. Logic level specifications

Where not specifically stated, all the interface circuits work at 2.8V CMOS logic levels. To get more detailed information about the logic level specifications used in the **Telit GE864** and **Telit GC864** interface circuits please consult the Hardware User Guide.



3.12.1. Reset signal

Signal	Function	I/O	GE864 ball	GC864 pin
RESET	Phone reset	I/O	A2	54

RESET is used to reset the **GE864** and **GC864**. Whenever this signal is pulled low, the **GE864 / GC864** is reset. When the device is reset it stops any operation and after the release of the reset it is unconditionally rebooted, without doing any detach operation from the network where it is registered to. This behavior is not like a proper shut down because any GSM device is requested to issue a detach request on turn off. For this reason, the Reset signal must not be used to normally shutting down the device, but only as an emergency exit in the rare case the device remains stuck waiting for some network response.

The RESET is internally controlled on start-up to achieve always a proper power-on reset sequence, so there is no need to control this pin on start-up. It may only be used to reset a device already switched on that is not responding to any command.



WARNING:

Do not use this signal to power off the Telit GE864 / GC864 modules. Use the ON_OFF* signal to perform this function or the AT#SHDN command instead.

3.13. Audio levels specifications

The audio of the **GE864 / GC864** modules is organized into two main paths:

internal path (called also MT)
external path (called also HF)

These two paths are meant respectively for handset and headset/hands-free use. The **GE864 / GC864** has a built in echo canceller and a noise suppressor, tuned separately for the two audio paths; for the internal path the echo canceller parameters are suited to cancel the echo generated by a handset, while for the external audio path they are suited for a hands-free use.

For more information on the audio, refer to the Hardware User Guide.



3.14. Converters

3.14.1. ADC Converter

The on-board ADCs are 11-bit converters. They are able to read a voltage level in the range of 0÷2 volts applied on the ADC pin input, store and convert it into 11 bit word.

	Min	Max	Units
Input Voltage range	0	2	Volt
AD conversion	-	11	bits
Resolution	-	< 1	mV
Sampling rate	1 (idle)	60 (on traffic)	sec

3.14.2. DAC Converter

The on board DAC is a 10-bit converter, able to generate an analogue value based a specific input in the range from 0 up to 1023. However, an external low-pass filter is necessary. See the HW User Guide for the details.

	Min	Max	Units
Voltage range (filtered)	0	2,6	Volt
Range	0	1023	Steps



3.15. Mounting the GE864 on your Board

3.15.1. General

The **Telit GE864 modules** have been designed in order to be compliant with a standard lead-free SMT process. For detailed information about PCB pad design and conditions to use in SMT process, please consult GE864 Hardware User Guide.

3.16. Mounting the GC864 on your board

The position of the Molex board to board connector and the pin 1 are shown in the following picture.

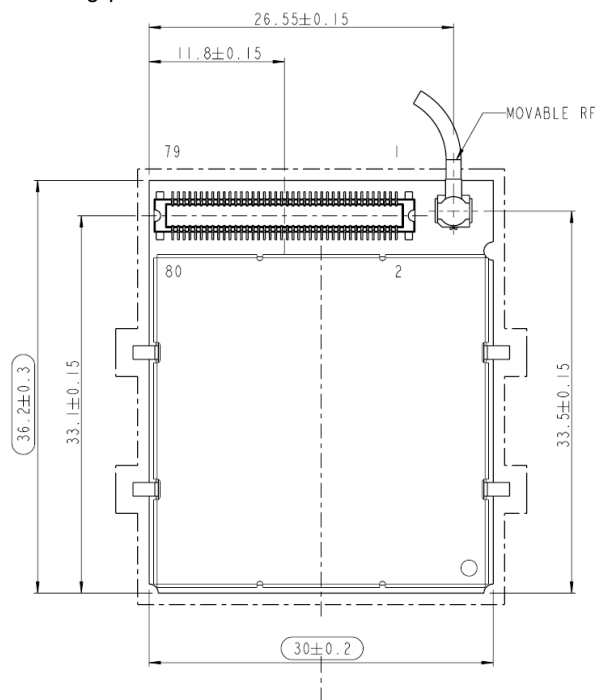

NOTICE:

Metal tabs present on GC864 should be connected to GND.



4. Packing system

The **Telit GE864-QUAD/PY** and **GC864** are packaged on trays of 20 pieces each. This is especially suitable for the GE864 according to SMT processes for pick & place movement requirements. Moreover, GE864-QUAD/PY is also available in 200-pieces reels.

4.1. GE864-QUAD/PY Package

4.1.1. GE864-QUAD/PY Tray package

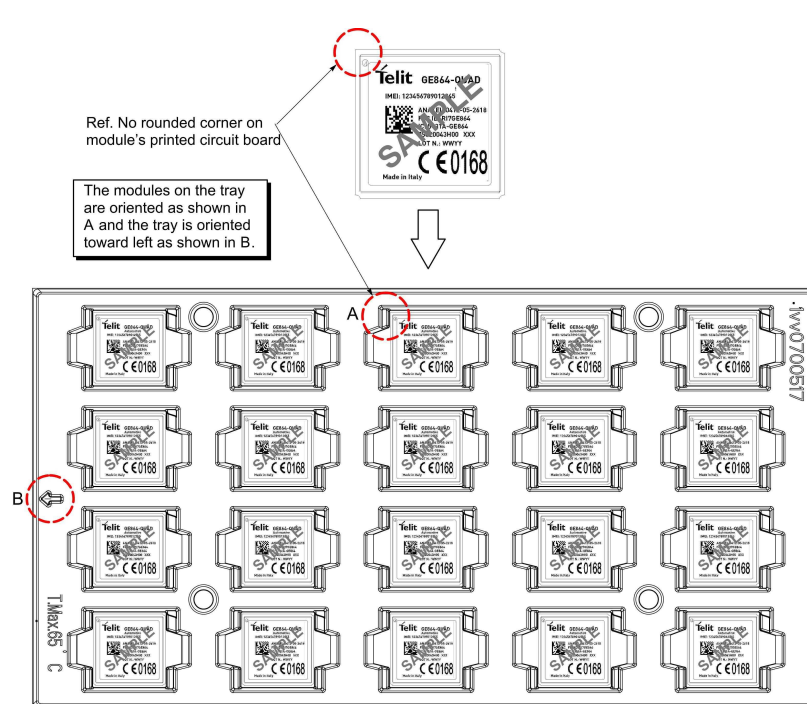

The size of the tray is: 329 x 176mm



WARNING:

These trays can withstand at the maximum temperature of 65° C.



Telit GE864 and GC864 Product Description
80273ST10008a Rev. 17-2009-12-01

4.1.2. GE864-QUAD/PY Reel package

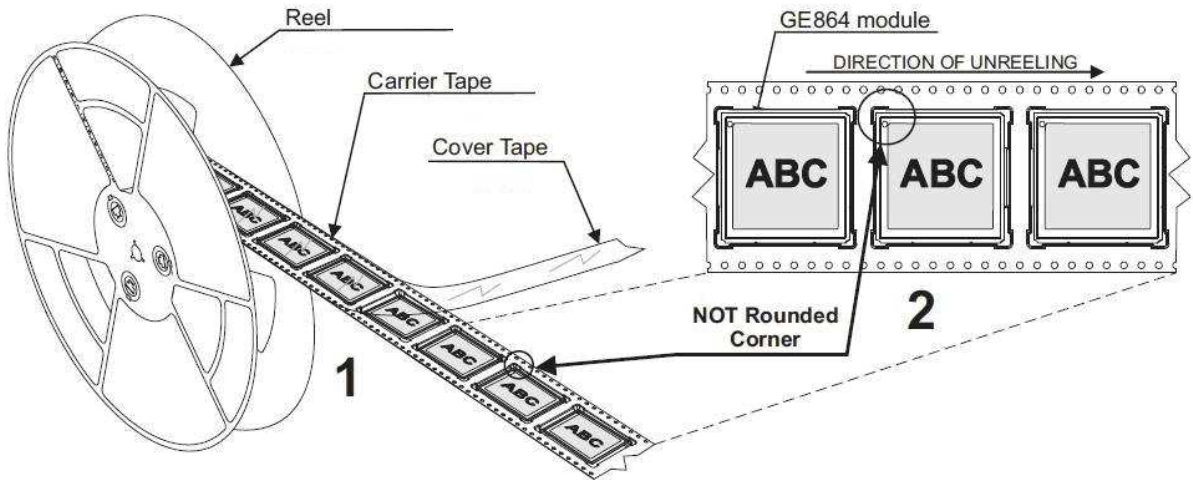

4.2. GC864 QUAD/PY package

The modules are placed in the tray up side down and oriented as shown in figure.

The tray is oriented toward left (see particular A)

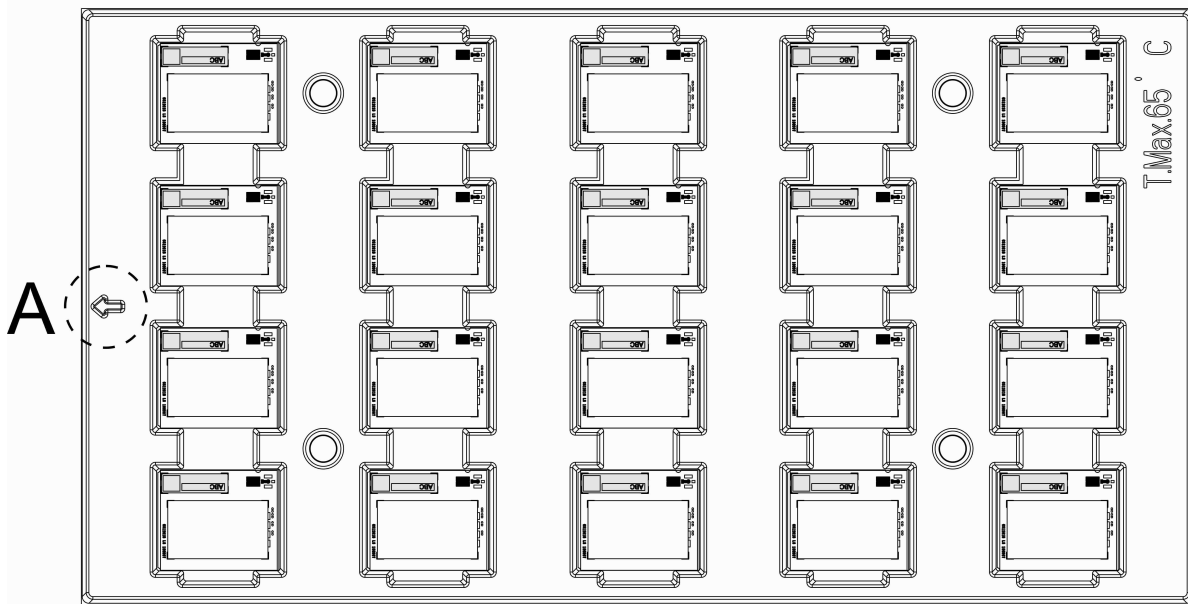

WARNING:

These trays can withstand at the maximum temperature of 65° C.



5. Evaluation Kit

In order to assist you in the development of your **Telit GE864 / GC864 module** based application, Telit can supply the **EVK2 Evaluation Kit** with appropriate power supply, SIM card housing, RS 232 serial port level translator, direct UART connection, Handset, Headset and Hands-free (car kit) audio, antenna.

The **EVK2** provides a fully functional solution for a complete data/phone application. The standard serial RS232 9 pin connector placed on the **Evaluation Kit** allows the connection of the **EVK2** system with a PC or other DTE.

The development of the applications utilizing the **Telit GE864 / GC864 module** must present a proper design of all the interfaces towards and from the module (e.g. power supply, audio paths, level translators), otherwise a decrease in the performances will be introduced or, in the worst case, a wrong design can even lead to an operating failure of the module.

In order to assist the hardware designer in his project phase, the **EVK2** board presents a series of different solutions, which will cover the most common design requirements on the market, and which can be easily integrated in the OEM design as building blocks or can be taken as starting points to develop a specific one.

The **EVK2** is an open air PCB, produced to ease the application development for Telit customers. As far as radio frequencies, the **EVK2** is shieldless, and should not be used as reference design.



GE864 Evaluation Kit



Telit GE864 and GC864 Product Description
80273ST10008a Rev. 17-2009-12-01

For a detailed description of the **Telit Evaluation Kit** refer to the documentation provided with the Telit **GE864 / GC864** Hardware User Guide and EVK2 User Manual.



6. Software Features

6.1. Easy GPRS Extension

6.1.1. Overview

The Easy GPRS feature allows the **Telit GE864 / GC864** user to contact a device in internet and establish with it a raw data flow over the GPRS and Internet networks. This feature can be seen as a way to obtain a "virtual" serial connection between the Application Software on the Internet machine involved and the controller of the **Telit GE864 / GC864** module, regardless of all the software stacks underlying. An example of the protocol stack involved in the devices is reported:

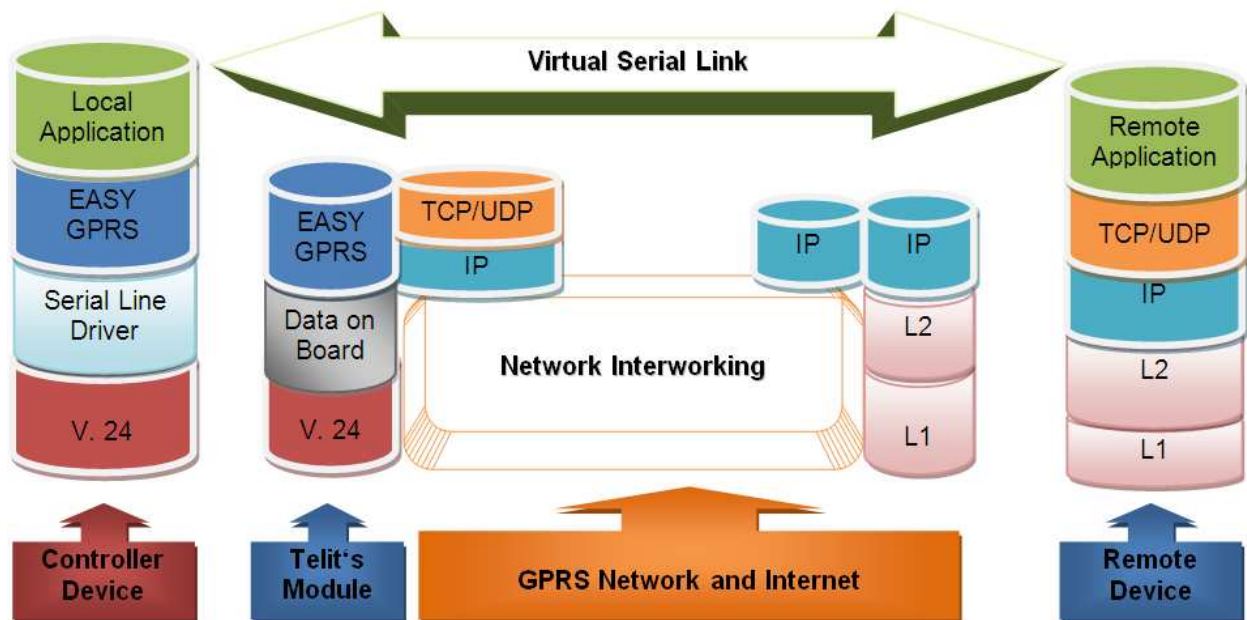

Telit GE864 and GC864 Product Description

80273ST10008a Rev. 17-2009-12-01

This particular implementation allows to the devices interfacing to the **Telit GE864 / GC864** module the use of the GPRS and Internet packet service without the need to have an internal TCP/IP stack since this function is embedded inside the module.

Easy GPRS overcomes some of the known limitations of the previous implementation and implements some new features such as:

Keeping the GPRS context active even after the closing of a socket, allowing the application to keep the same IP address;
Also Mobile terminated (incoming) connections can be made, now it is possible to receive incoming TCP connection requests;
A new internal firewall has been implemented in order to guarantee a certain level of security on internet applications.

6.1.2. Easy GPRS definition

The Easy GPRS feature provides a way to replace the need of an Internet TCP/IP stack at the terminal equipment side. The steps that will be required to obtain a virtual serial connection (that is actually a socket) to the Internet peer are:

- configuring the GPRS Access
- configuring the embedded TCP/IP stack behavior
- defining the Internet Peer to be contacted
- request the GPRS and socket connections to be opened (host is connected)
- exchange raw data
- close the socket and GPRS context

All these steps are achieved through AT commands.

As for common modem interface, two logical statuses are involved: command mode and data traffic mode.

In Command Mode (CM), some AT commands are provided to configure the Data Module Internet stack and to start up the data traffic.

In data traffic mode (Socket Mode, SKTM), the client can send/receive a raw data stream which will be encapsulated in the previously configured TCP / IP packets which will be sent to the other side of the network and vice versa. Control plane of ongoing socket connection is deployed internally to the module.

For more detailed information regarding GPRS please consult Easy GPRS User Guide and AT Commands Reference Guide.



6.2. Multisocket

As a new functionality of the Telit modules, multisocket is an extension of Telit Easy GPRS feature, which allows the user to have two contexts activated (that means two different IP address), more than one socket connection (with a maximum of 6) and simultaneous FTP client service.

The basic idea of multisocket is the possibility of suspend a socket connection with the escape sequence +++.

With IP Easy we can use a SKTD to open a socket connection and go online. After online activities we use +++ sequence to close the connection (see the figure below).



Where the green part represents the module command mode while the red part is the online mode.

Now, the online mode can be suspended with the escape sequence by using the multisocket feature. During suspend mode the data received by the socket will be buffered. These data will be displayed after socket resumption, as shown in the figure below:

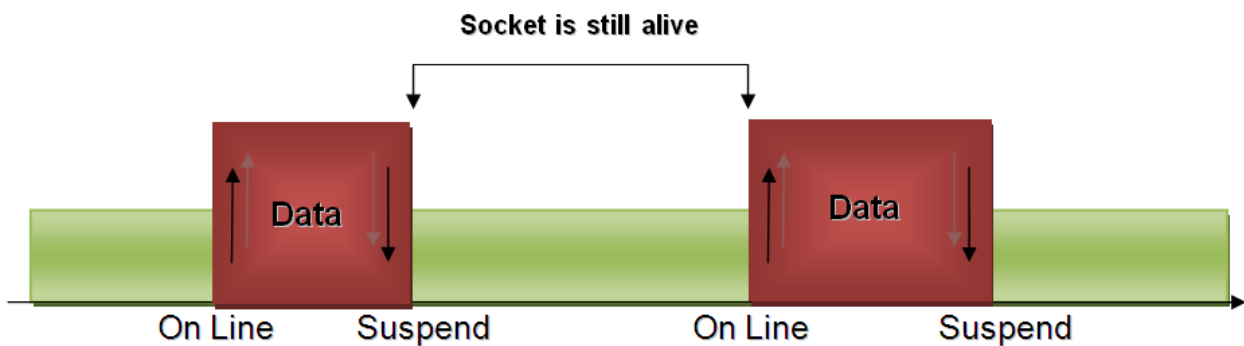

Telit GE864 and GC864 Product Description

80273ST10008a Rev. 17-2009-12-01

This new feature allows the user to switch between online mode and command mode without closing the connection and eventually opening another socket (or resuming the suspended one) or FTP connection.

Another feature is the possibility to associate any socket connection to a specific context, this means that we can use different IP addresses for the connections (max 2). Socket identifier is called Connection Id (selects which socket we want to use from 1 up to 6) and every Connection Id is associated to a context.

For more detailed information, please consult Easy GPRS User Guide.

6.3. Jammed Detect & Report Extension

6.3.1. Overview

The Jammed Detect & Report feature allows a **Telit GE864 / GC864** to detect the presence of a disturbing device such as a Communication Jammer and give indication to the user and/or send a report of that to the network.

This feature can be very important in alarm, security and safety applications that rely on the module for the communications. In these applications, the presence of a Jammer device can compromise the whole system reliability and functionality and therefore shall be recognized and reported either to the local system for countermeasure actions or to the network providing remote actions.

An example scenario could be an intrusion detection system that uses the module for sending the alarm indication for example with an SMS to the system owner, and a thief income using a Jammer to prevent any communication between the GSM module and the network.

In such a case, the module detects the Jammer presence even before the break in and can trigger an alarm siren, other communication devices (PSTN modem) or directly report this condition to the network that can provide further security services for example sending SMS to the owner or police. Obviously, this last service depends also from network infrastructure support and it may not be supported by some networks.

6.4. CMUX

CMUX (Converter-Multiplexer) is a multiplexing protocol implemented in the Telit module that can be used to send any data, SMS, fax, TCP data.



6.4.1. Product architecture

The Multiplexer mode enables one serial interface to transmit data to four different customer applications. This is achieved by providing four virtual channels using a Multiplexer (Mux).

This is especially advantageous when a fax/data/GPRS call is ongoing. Using the Multiplexer features, e.g. controlling the module or using the SMS service can be done via the additional channels without disturbing the data flow; access to the second UART is not necessary.

Furthermore, several accesses to the module can be created with the Multiplexer. This is of great advantage when several independent electronic devices or interfaces are used.

To access the three virtual interfaces, both the GSM engine and the customer application must contain MUX components, which communicate over the multiplexer protocol.

In Multiplexer mode, AT commands and data are encapsulated into packets. Each packet has channel identification and may vary in length.

6.4.2. Implementation feature and limitation

7.10 CMUX Basic Option used;
CMUX implementation support four full DLCI (Serial Port);
Every CMUX instance has its own user profile storage in NVM;
Independent setting of unsolicited message;
In case of GPS product one serial port can be dedicated to NMEA output;
Every CMUX instance has its own independent flow control.



NOTICE:

More details about the Multiplexer mode are available in the Cmux User Guide.



6.5. Easy Script Extension - Python interpreter

6.5.1. Overview



NOTICE:

This feature is available only for the **Telit GE864-PY and GC864-PY**.

The Easy Script Extension is a feature that allows driving the modem "internally", writing the controlling application directly in a nice high-level language as Python. The Easy Script Extension is aimed at low complexity applications where the application was usually done by a small microcontroller that managed some I/O pins and the GE864-PY and GC864-PY through the AT command interface.

A schematic of such a configuration can be:

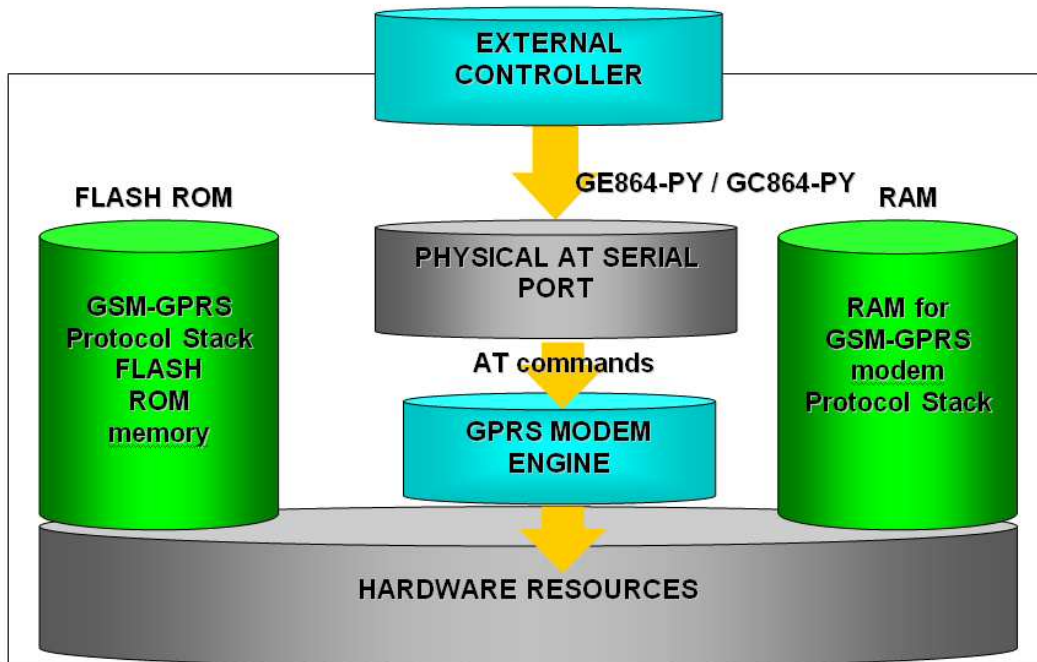

In order to eliminate this external controller, and further simplify the programming of the sequence of operations, inside the GE864-PY / GC864-PY it is included:

- Python script interpreter engine v. 1.5.2+;
- around 3MB of Non Volatile Memory room for the user scripts and data;
- 1 MB RAM reserved for Python engine usage;



Telit GE864 and GC864 Product Description
80273ST10008a Rev. 17-2009-12-01

A schematic of this approach is:

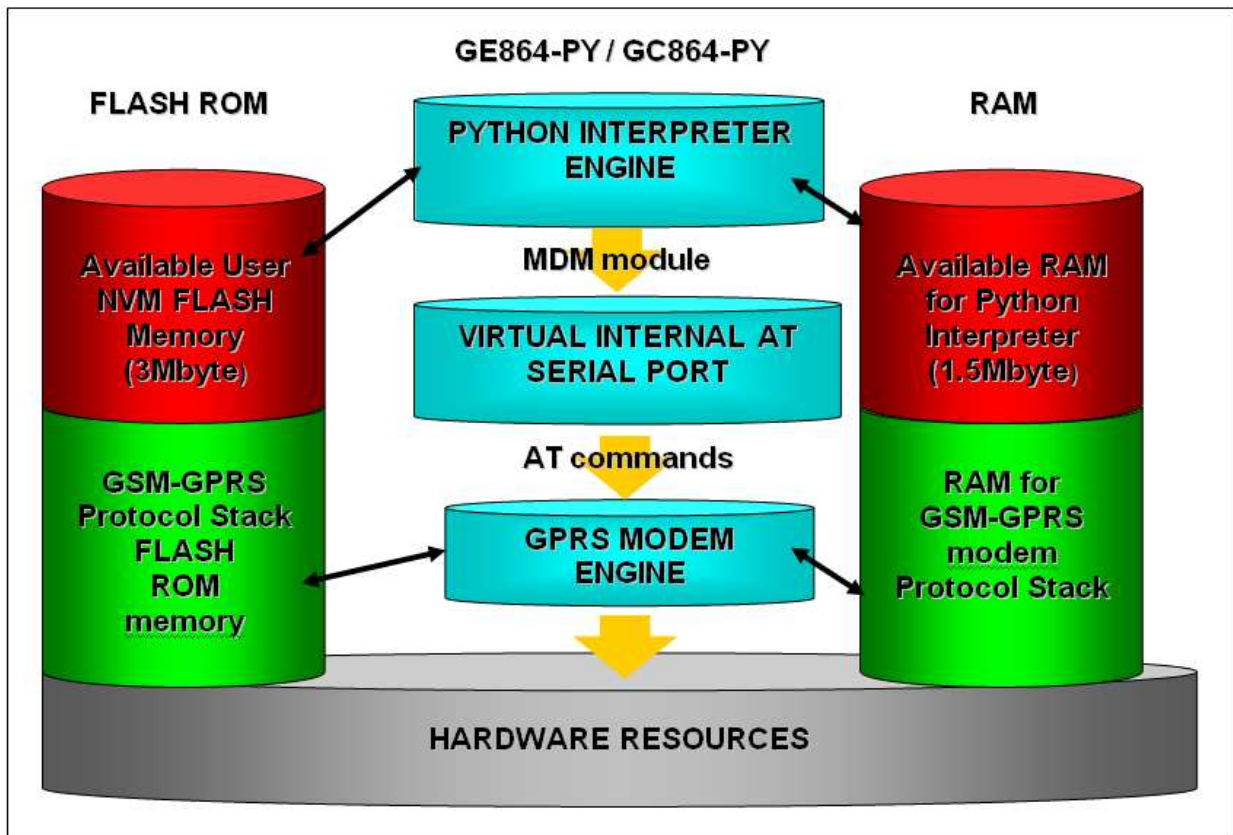
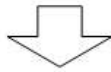

6.5.2. Python 1.5.2+ Copyright Notice

The Python code implemented into the **Telit module** is copyrighted by Stichting Mathematisch Centrum, this is the license:

Copyright © 1991-1995 by Stichting Mathematisch Centrum, Amsterdam, The Netherlands.

All Rights Reserved

Copyrig©(c) 1995-2001 Corporation for National Research Initiatives; All Rights Reserved.

Copy©ht (c) 2001, 2002, 2003, 2004 Python Software Foundation; All Rights Reserved.

C©right (c) 2001-2008 Python Software Foundation; All Rights Reserved.

All Rights Reserved are retained in Python.

Permission to use, copy, modify, and distribute this software and its documentation for any purpose and without fee is hereby granted, provided that the above copyright notice appear in all copies and that both that copyright notice and this permission notice appear in supporting documentation, and that the names of Stichting Mathematisch Centrum or CWI or Corporation for National Research Initiatives or CNRI not be used in advertising or publicity pertaining to distribution of the software without specific, written prior permission.

While CWI is the initial source for this software, a modified version is made available by the Corporation for National Research Initiatives (CNRI) at the Internet address <ftp://ftp.python.org>.

STICHTING MATHEMATISCH CENTRUM AND CNRI DISCLAIM ALL WARRANTIES WITH REGARD TO THIS SOFTWARE, INCLUDING ALL IMPLIED WARRANTIES OF MERCHANTABILITY AND FITNESS, IN NO EVENT SHALL STICHTING MATHEMATISCH CENTRUM OR CNRI BE LIABLE FOR ANY SPECIAL, INDIRECT OR CONSEQUENTIAL DAMAGES OR ANY DAMAGES WHATSOEVER RESULTING FROM LOSS OF USE, DATA OR PROFITS, WHETHER IN AN ACTION OF CONTRACT, NEGLIGENCE OR OTHER TORTIOUS ACTION, ARISING OUT OF OR IN CONNECTION WITH THE USE OR PERFORMANCE OF THIS SOFTWARE.



6.5.3. Python implementation description

Python scripts are text files stored in NVM inside the **Telit GE/GC864-PY**. There is a file system inside the module that allows to write and read files with different names on one single level (no subdirectories are supported).

Attention: it is possible to run only one Python script at a time.

The Python script is executed in a task inside the **Telit module** at the lowest priority, making sure this does not interfere with GSM/GPRS normal operations. This allows serial ports, protocol stack etc. to run independently from the Python script.

The Python script interacts with the **Telit module** functionality through four built-in interfaces.



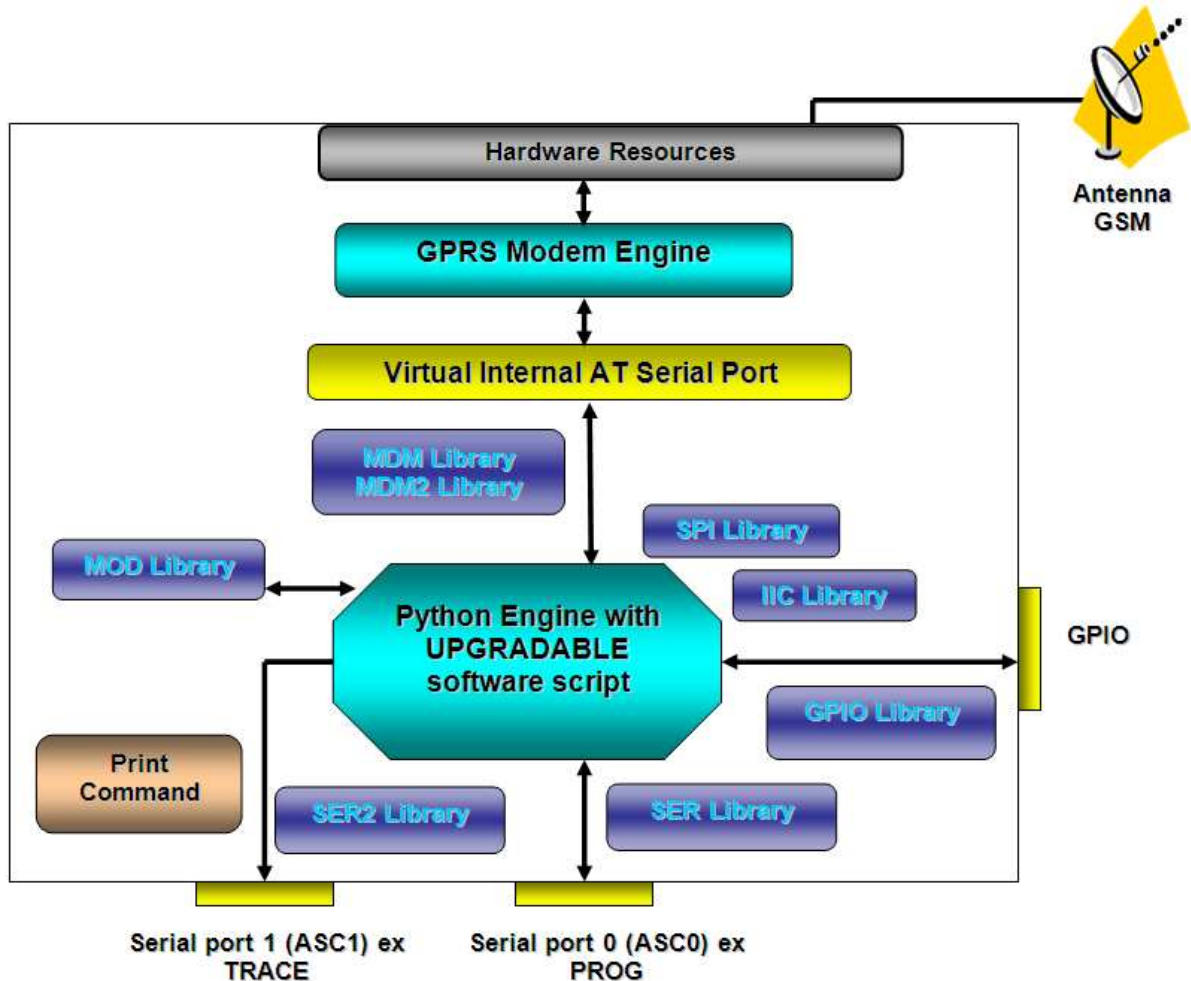

The **MDM interface** is the most important one. It allows Python script to send AT commands, receive responses and unsolicited indications, send data to the network and receive data from the network during connections. It is quite the same as the usual serial port interface in the **Telit module**. The difference is that this interface is not a real serial port but just an internal software bridge between Python and mobile internal AT command handling engine. All AT commands working in the **Telit module** are working in this software interface as well. Some of them have no meaning on this interface, such as those regarding serial port settings. The usual concept of flow control keeps its meaning over this interface, but it's managed internally.

The **MDM2 interface** is the second interface between Python and mobile internal AT command handling. It is used to send AT commands from Python script to mobile and receive AT responses from mobile to Python script when the classic MDM built-in module is already in use.



Telit GE864 and GC864 Product Description
80273ST10008a Rev. 17-2009-12-01

The SER interface allows Python scripts to read from and write to the *real*, physical serial port where usually the AT command interface resides, for example to read NMEA information from a GPS device. When Python is running, this serial port is free to be used by Python scripts because it is not used as AT command interface since the AT parser is mapped into the internal virtual serial port. No flow control is available from Python on this port.

The SER2 interface allows Python scripts to read from and write to the *real* physical serial port ASC1, that is usually available for trace and debug.

The GPIO interface allows Python scripts to handle general purpose input/output faster than through AT commands, skipping the command parser and controlling directly the pins.

The MOD interface is a collection of useful functions.

The IIC interface is an implementation on the Python core of the IIC bus Master. It allows Python to create one or more IIC bus on the available GPIO pins.

The SPI interface is an implementation on the Python core of the SPI bus Master. It allows Python to create one or more SPI bus on the available GPIO pins.

For the debug, the print command is directly forwarded on the EMMI TX pin (second serial port) at baud rate 115200bps 8N1.

6.5.4. Python core supported features

The Python core version is 1.5.2+ (string methods added to 1.5.2). You can use all Python statements and almost all Python built-in types and functions.

Built-in types and functions not supported	Available modules (all others are not supported)
complex	marshal
float	imp
long	<code>_main_</code>
docstring	<code>_builtin_</code>
	sys
	md5



6.6.2. Implementation features

SAP is based on 7.10 CMUX Basic Option used;
Only SAP Client features;
Logic HW flow control is recommended on the Virtual instance selected for the SAP command.

6.6.3. Remote SIM Message Command Description

The module sends request commands to the client application through a binary message that is crowned in the CMUX message. The client application shall extract the message and send it to the SAP server, through the appropriate protocols (e.g. by RFCOMM, that is the Bluetooth serial port emulation entity).
The client application shall extract all the messages sent by SAP server and put them in the CMUX message, to sent to the module.

The module satisfies the following feature requirements:

- Connection management;
- Transfer APDU;
- Transfer ATR;
- Power SIM on;
- Report Status;
- Error Handling.

Every feature needs some procedures support:

Feature	Procedure
Connection Management	Connect
	Report Status
	Transfer ATR
	Disconnection Initiated by the Client
	Disconnection Initiated by the Server
Transfer APDU	Transfer APDU
Transfer ATR	Transfer ATR
Power SIM on	Power SIM on
	Transfer ATR
Report Status	Report Status
Error Handling	Error Response



Report Status, Disconnection Initiated by the Server and Error Response are independent messages sent by server. The other procedures consist of couples of messages, started by the client.



NOTICE:

More details about the SAP are available in the SAP User Guide.

6.7. PFM (Premium FOTA Management)

Premium FOTA Management (PFM) provides a cost-effective, fast, secure and reliable way for wirelessly update the firmware on mobile devices, ensuring that embedded software is up-to-date with the latest enhancements and features.

Customers, who want to benefit from this service, must pass through the Telit certification program, where Telit will assist the customer in validating the correct implementation of FOTA.

6.7.1. FOTA (Firmware Over-The-Air)

Telit, which has signed a partnership agreement with the worldwide leader of Firmware OTA technology Red Bend, has integrated its unique vCurrent® Mobile client software for use in its m2m product portfolio. Telit is therefore able to upgrade its products by transmitting only a delta file, which represents the difference between one firmware version and another.

All Telit modules, starting from SW version 7.03.x00, support Over-the-Air firmware update.



NOTICE:

Note that this service will be enabled only after signing specific agreement with Telit.

See INFINITA Services > FOTA for details in www.telit.com.



7. AT Commands

The **Telit GE864 / GC864 module** can be driven via the serial interface using the standard AT commands¹.

The Telit GE864 / GC864 module is compliant with:

Hayes standard AT command set, in order to maintain the compatibility with existing SW programs.

- ETSI GSM 07.07 specific AT command and GPRS specific commands.
- ETSI GSM 07.05 specific AT commands for SMS (Short Message Service) and CBS (Cell Broadcast Service)
- FAX Class 1 compatible commands

Moreover, the **Telit GE864 / GC864 module** support also Telit proprietary AT commands for special purposes.

For more information about AT commands supported by GE864/GC864 modules, please refer to document AT Commands Reference Guide, code 80000ST10025a.

¹ The AT is an ATTENTION command and is used as a prefix to other parameters in a string. The AT command combined with other parameters can be set up in the communications package or typed in manually as a command line instruction.



8. Drivers

The following drivers are available for GE/GC864:

Operation System	Revision	HW core	Driver	
			MUX	RIL
WinCE	6.0	ARMV4I	•	•

MUX driver allows the easy implementation of a multiplexed communication between Telit module and OEM application.

The Radio Interface Layer (RIL) provides an interface that handles the communication between the OEM application and the radio hardware.

Ask to TTSC for details.



9. Conformity Assessment Issues

The Telit **GE864** has been assessed in order to satisfy the essential requirements of the R&TTE Directive 1999/05/EC (Radio Equipment & Telecommunications Terminal Equipments) to demonstrate the conformity against the harmonized standards with the final involvement of a Notified Body.

CE0168

If the module is installed in conformance to the Telit installation manuals, no further evaluation under **Article 3.2** of the R&TTE Directive and do not require further involvement of a R&TTE Directive Notified Body for the final product.

In all other cases, or if the manufacturer of the final product is in doubt, then the equipment integrating the radio module must be assessed against **Article 3.2** of the R&TTE Directive.

In all cases the assessment of the final product must be made against the Essential requirements of the R&TTE Directive **Articles 3.1(a)** and **(b)**, Safety and EMC respectively, and any relevant Article 3.3 requirements.

This Product Description, the Hardware User Guide and Software User Guide contain all the information you may need for developing a product meeting the R&TTE Directive.

Furthermore the **GE864** module is FCC Approved as module to be installed in other devices. This device is to be used only for fixed and mobile applications. If the final product after integration is intended for portable use, a new application and FCC is required.

The **GE864** is conforming to the following US Directives:

- Use of RF Spectrum. Standards: FCC 47 Part 24 (GSM 1900)
- EMC (Electromagnetic Compatibility). Standards: FCC47 Part 15

This device complies with Part 15 of the FCC Rules. Operation is subject to the following two conditions:

- (1) this device may not cause harmful interference, and
- (2) this device must accept any interference received, including interference that may cause undesired operation.

To meet the FCC's RF exposure rules and regulations:



Telit GE864 and GC864 Product Description

80273ST10008a Rev. 17-2009-12-01

- The system antenna(s) used for this transmitter must be installed to provide a separation distance of at least 20 cm from all the persons and must not be co-located or operating in conjunction with any other antenna or transmitter.
- The system antenna(s) used for this module must not exceed 1.4dBi (850MHz) and 3.0dBi (1900MHz) for mobile and fixed or mobile operating configurations.
- Users and installers must be provided with antenna installation instructions and transmitter operating conditions for satisfying RF exposure compliance.

Manufacturers of mobile, fixed or portable devices incorporating this module are advised to clarify any regulatory questions and to have their complete product tested and approved for FCC compliance.



9.1. GE864-QUAD Conformity Assessment



DECLARATION OF CONFORMITY

We, **Telit Communications S.p.A**

Of: **Via Stazione di Prosecco, 5/b
34010 Sgonico (TRIESTE)
ITALY**

declare under our sole responsibility that the product

GE864-QUAD

to which this declaration relates is in conformity with all the essential requirements of Directive 1999/05/EC

The conformity with the essential requirements of the European Directive 1999/05/EC has been verified against the following harmonized standards:

- ETSI EN 301 511 Mobile stations in GSM 900 and DCS1800;
- CENELEC EN 60950 Safety of information technology equipments;
- ETSI EN 301 489-7 EMC&ERM Specific for GSM and DCS telecommunications systems.

The conformity assessment procedure referred to in Article 10 and detailed in Annex IV of Directive 1999/5/EC has been followed with the involvement of the following Notified Body:

BABT, Balfour House, Churchfield Road, Walton-on-Thames, Surrey, KT12 2TD, United Kingdom

Identification mark: **0168**

The technical documentation relevant to the above equipment will be held at:

**Telit Communications S.p.A
Via Stazione di Prosecco, 5/b
34010 Sgonico (TRIESTE)
ITALY**

Trieste, **08 february 2006**



Ing. Guido Walcher
 Quality Assurance Director

06DOC04 MOD.003 02/06 REV.9



Telit GE864 and GC864 Product Description
80273ST10008a Rev. 17-2009-12-01

ZERTIFIKAT • CERTIFICATE • 認証証書 • CERTIFICADO • CERTIFICAT

Certificate

This certificate is issued to

TELIT Communications S.p.A.

of

Viale Stazione di Prosecco 5/B
34010 Sgonico
Trieste
Italy

to certify that the Equipment known as

GE864-QUAD

as described in the Annex to this certificate conforms to the essential requirements of Directive 1999/5/EC of the European Parliament and European Council on the basis of Technical Construction File number 22345_GE864-QUAD_rev1 in relation to the essential requirements of Articles 3.1(a), 3.1(b) & 3.2 of the Directive.

Signed: 
On Behalf of BABT

Issue Date: 08 February 2006

Number: NC/12659 Issue: 01

This certificate is issued by BABT and represents a formal Notified Body opinion under Annex IV of Directive 1999/5/EC permitting the use of the BABT (C0168) mark on the equipment described above subject to the equipment meeting the compliance requirements of all applicable EU directives. This certificate is not transferable and remains the property of BABT.

British Approvals Board for Telecommunications • TÜV SÜD Group •
Bolt in House • Churchfield Road • Walton-on-Thames • Surrey • KT12 2TD • United Kingdom





9.2. GE864-PY Conformity Assessment



DECLARATION OF CONFORMITY

We, **Telit Communications S.p.A**

Of: **Via Stazione di Prosecco, 5/b
34010 Sgonico (TRIESTE)
ITALY**

declare under our sole responsibility that the product

GE864-PY

to which this declaration relates is in conformity with all the essential requirements of Directive 1999/05/EC

The conformity with the essential requirements of the European Directive 1999/05/EC has been verified against the following harmonized standards:

- ETSI EN 301 511 v.9.0.2;
- CENELEC EN 60950:2001;
- ETSI EN 301 489-1: v.1.4.1;
- ETSI EN 301 489-7: v.1.2.1.

The conformity assessment procedure referred to in Article 10 and detailed in Annex IV of Directive 1999/5/EC has been followed with the involvement of the following Notified Body:

BABT, Balfour House, Churchfield Road, Walton-on-Thames, Surrey, KT12 2TD, United Kingdom

Identification mark: **0168**

The technical documentation relevant to the above equipment will be held at:

**Telit Communications S.p.A
Via Stazione di Prosecco, 5/b
34010 Sgonico (TRIESTE)
ITALY**

Trieste, **04 July 2006**

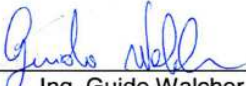
 Ing. Guido Walcher
 Quality Assurance Director

06DOC05 MOD.003 02/06 REV.9



ZERTIFIKAT • CERTIFICATE • 認証証書 • CERTIFICADO • CERTIFICAT



Certificate

This certificate is issued to

TELIT Communications S.p.A.

of

Via Stazione di Prosecco 5/B
34010 Sgonico
Trieste
Italy

to certify that the Equipment known as

GE864-PY

as described in the Annex to this certificate
conforms to the essential requirements of Directive 1999/5/EC
of the European Parliament and European Council on the basis
of Technical Construction File number 24552_GE864-PY_rev1
in relation to the essential requirements of
Articles 3.1(a), 3.1(b) & 3.2 of the Directive.

Signed: 

On Behalf of BABT

Issue Date: 4th July 2006

Number: NC/12830 Issue: 01

This certificate is issued by BABT and represents a formal Notified Body opinion under Annex IV of Directive 1999/5/EC permitting the use of the BABT (E0168) mark on the equipment described above subject to the equipment meeting the compliance requirements of all applicable EU directives. This certificate is not transferable and remains the property of BABT.

British Approvals Board for Telecommunications • TÜV SÜD Group •
Balfour House • Churchfield Road • Walton-on-Thames • Surrey • KT12 2TD • United Kingdom





9.3. GE864-QUAD/PY: RoHS certificate



DECLARATION OF EU RoHS Compliance

We, *Telit Communications S.p.A*

Of: *Via Stazione di Prosecco, 5/b
34010 Sgonico (TRIESTE)
ITALY*

declare under our sole responsibility that the:

GE864-QUAD products family

to which this declaration relates, is in full compliance with EU Directive 2002/95/EC on Restriction of the use of certain Hazardous Substances in electrical and electronic equipment (RoHS), subsequent amendments, the European Court of Justice decision on Deca-BDE substance from July 1st 2008, and EU Directive 2006/122/EC on restrictions on the market and use of certain dangerous substances and preparations (perfluorooctane sulfonates PFOS and PFOA).

Telit bases its material content knowledge on the test report n. CE/2008/B6490, provided by SGS Chemical Analysis Laboratory dated 2008/12/02.

The technical documentation and other information showing that the electrical and electronic equipment which has put on the market complies the requirements of regulations are held at:

*Telit Communications S.p.A
Via Stazione di Prosecco, 5/b
34010 Sgonico (TRIESTE)
ITALY
Trieste October 06, 2009*



Guido Walcher
EMEA Quality Director



9.4. GC864-QUAD: Conformity Assessment

 **DECLARATION OF CONFORMITY**

We,
Telit Communications S.p.A

Of:
**Via Stazione di Prosecco, 5/b
34010 Sgonico (TRIESTE)
ITALY**

declare under our sole responsibility that the product
GC864-QUAD

to which this declaration relates is in conformity with all the essential requirements of Directive 1999/05/EC

The conformity with the essential requirements of the European Directive 1999/05/EC has been verified against the following harmonized standards:

- ETSI EN 301 511 v.9.0.2;
- CENELEC EN 60950:2001;
- ETSI EN 301 489-1: v.1.4.1;
- ETSI EN 301 489-7: v.1.2.1.

The conformity assessment procedure referred to in Article 10 and detailed in Annex IV of Directive 1999/5/EC has been followed with the involvement of the following Notified Body:

**BABT, Balfour House, Churchfield Road, Walton-on-Thames, Surrey, KT12
2TD, United Kingdom**

Identification mark: **0168**

The technical documentation relevant to the above equipment will be held at:

**Telit Communications S.p.A
Via Stazione di Prosecco, 5/b
34010 Sgonico (TRIESTE)
ITALY**

Trieste, **28 July 2006**

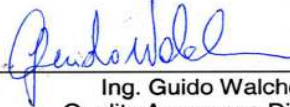
Ing. Guido Walcher
Quality Assurance Director

06DOC10 MOD.003 02/06 REV.9



Telit GE864 and GC864 Product Description
80273ST10008a Rev. 17-2009-12-01

ZERTIFIKAT • CERTIFICATE • 認証証書 • CERTIFICADO • CERTIFICAT



Certificate

This certificate is issued to

TELIT Communications S.p.A.

of

Via Stazione di Prosecco 5/B
34010 Sgonico
Trieste
Italy

to certify that the Equipment known as

GC864-QUAD

as described in the Annex to this certificate conforms to the essential requirements of Directive 1999/5/EC of the European Parliament and European Council on the basis of Technical Construction File number 24383_GC864-QUAD_rev1 in relation to the essential requirements of Articles 3.1(a), 3.1(b) & 3.2 of the Directive.

Signed: 

On Behalf of BABT

Issue Date: 28 July 2006

Number: NC/12869 Issue: 01



This certificate is issued by BABT and represents a formal Notified Body opinion under Annex IV of Directive 1999/5/EC permitting the use of the BABT CE0168 mark on the equipment described above subject to the equipment meeting the compliance requirements of all applicable EU directives. This certificate is not transferable and remains the property of BABT.

British Approvals Board for Telecommunications • TÜV SÜD Group •
Ballour House • Churchfield Road • Walton-on-Thames • Surrey • KT12 2TD • United Kingdom





9.5. GC864-PY: Conformity Assessment

	DECLARATION OF CONFORMITY
We,	Telit Communications S.p.A
Of:	Via Stazione di Prosecco, 5/b 34010 Sgonico (TRIESTE) ITALY
declare under our sole responsibility that the product	
GC864-PY	
to which this declaration relates is in conformity with all the essential requirements of Directive 1999/05/EC	
The conformity with the essential requirements of the European Directive 1999/05/EC has been verified against the following harmonized standards:	
<ul style="list-style-type: none">• ETSI EN 301 511 v.9.0.2;• CENELEC EN 60950:2001;• ETSI EN 301 489-1: v.1.4.1;• ETSI EN 301 489-7: v.1.2.1.	
The conformity assessment procedure referred to in Article 10 and detailed in Annex IV of Directive 1999/5/EC has been followed with the involvement of the following Notified Body:	
BABT, Balfour House, Churchfield Road, Walton-on-Thames, Surrey, KT12 2TD, United Kingdom	
Identification mark:	0168
The technical documentation relevant to the above equipment will be held at:	
Telit Communications S.p.A Via Stazione di Prosecco, 5/b 34010 Sgonico (TRIESTE) ITALY	
Trieste, 28 July 2006	 Ing. Guido Walcher Quality Assurance Director
06DOC11 MOD.003 02/06 REV.9	



ZERTIFIKAT • CERTIFICATE • 証証証書 • CERTIFICADO • CERTIFICAT



Certificate

This certificate is issued to

TELIT Communications S.p.A.

of

Via Stazione di Prosecco 5/B
34010 Sgonico
Trieste
Italy

to certify that the Equipment known as

GC864-PY

as described in the Annex to this certificate conforms to the essential requirements of Directive 1999/5/EC of the European Parliament and European Council on the basis of Technical Construction File number 23546_GC864-PY_rev1 in relation to the essential requirements of Articles 3.1(a), 3.1(b) & 3.2 of the Directive.

Signed:



On Behalf of BABT

Issue Date: 28 July 2006

Number: NC/12870 Issue: 01

This certificate is issued by BABT and represents a formal Notified Body opinion under Annex IV of Directive 1999/5/EC permitting the use of the BABT CE0168 mark on the equipment described above subject to the equipment meeting the compliance requirements of all applicable EU directives. This certificate is not transferable and remains the property of BABT.

British Approvals Board for Telecommunications • TÜV SÜD Group •
Balfour House • Churchfield Road • Walton-on-Thames • Surrey • KT12 2TD • United Kingdom





9.6. GC864-QUAD/PY: RoHS certificate



DECLARATION OF EU RoHS Compliance

We, **Telit Communications S.p.A**

Of: **Via Stazione di Prosecco, 5/b
34010 Sgonico (TRIESTE)
ITALY**

declare under our sole responsibility that the products:

GC864-PY
GC864-QUAD

to which this declaration relates, is in full compliance with EU Directive 2002/95/EC on restriction of the use of certain Hazardous Substances in electrical and electronic equipment (RoHS), subsequent amendments and the European Court of Justice decision on Deca-BDE substances from July 1, 2008.

The technical documentation or other information showing that electrical and electronic equipment which has put on the market, complies the requirements of regulation, will be held at:

Telit Communications S.p.A
Via Stazione di Prosecco, 5/b
34010 Sgonico (TRIESTE)
ITALY
Trieste, **August 1st, 2008**

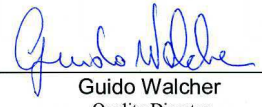
 _____ Antonino Sgroi R&D Head	 _____ Guido Walcher Quality Director
--	--

Rev.2



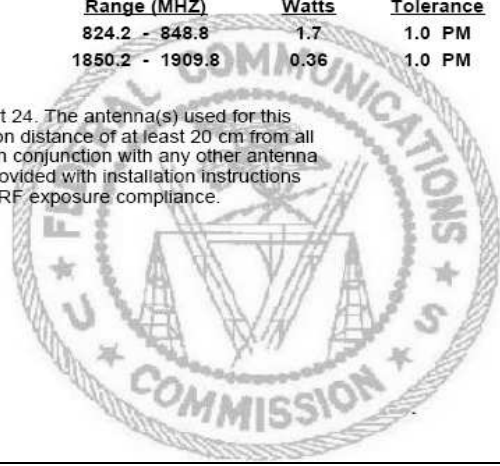

9.7. GE864-QUAD/PY: FCC Equipment Authorization

TCB	<p>GRANT OF EQUIPMENT AUTHORIZATION</p> <p>Certification Issued Under the Authority of the Federal Communications Commission</p> <p>By:</p> <p>MET Laboratories, Inc. 914 W. Patapsco Avenue Baltimore, MD 21230-3432</p>	TCB	<p>Date of Grant: 07/13/2006</p> <p>Application Dated: 07/13/2006</p>		
<p>Telit Communications S.p.A. Viale Stazione di Prosecco 5/b Trieste, 34010 Italy</p> <p>Attention: Andrea Fragiaco, Ing.</p>					
<p>NOT TRANSFERABLE</p> <p>EQUIPMENT AUTHORIZATION is hereby issued to the named GRANTEE, and is VALID ONLY for the equipment identified hereon for use under the Commission's Rules and Regulations listed below.</p>					
<p>FCC IDENTIFIER: RI7GE864</p> <p>Name of Grantee: Telit Communications S.p.A.</p> <p>Equipment Class: PCS Licensed Transmitter</p> <p>Notes: GSM 850/1900MHz Module</p>					
<u>Grant Notes</u>	<u>FCC Rule Parts</u>	<u>Frequency Range (MHZ)</u>	<u>Output Watts</u>	<u>Frequency Tolerance</u>	<u>Emission Designator</u>
	22H	824.2 - 848.8	1.7	1.0 PM	290KGXW
	24E	1850.2 - 1909.8	0.36	1.0 PM	290KGXW
<p>Power Output is ERP for Part 22 and EIRP for Part 24. The antenna(s) used for this transmitter must be installed to provide a separation distance of at least 20 cm from all persons and must not be co-located or operating in conjunction with any other antenna or transmitter. Installers and end-users must be provided with installation instructions and transmitter operating conditions for satisfying RF exposure compliance.</p>					



9.9. GE864-QUAD/PY: IC Equipment Authorization

			
GRANT OF EQUIPMENT CERTIFICATION THE FOLLOWING EQUIPMENT HAS BEEN TESTED AND CERTIFIED UNDER INDUSTRY CANADA RSS 132 ISSUE 1 PROVISIONAL AUG. 2002, RSS 133 ISSUE 3, JUNE 2005			
CB	Issued By: MET Laboratories, Inc. 914 W. Patapsco Avenue Baltimore, Maryland 21230 Laboratory Number: 2043	CB	
Equipment Certification is hereby issued to the Identified Certificate Holder and is VALID ONLY for the equipment identified herein. NOT TRANSFERABLE			
FILE/CERTIFICATE NUMBER: 074-07-2006-20240			
CERTIFICATION NUMBER: 5131A-GE864			
Issued to: Address:	Telit Communications S.p.A Viale Stazione di Prosecco 5/B I-34010 Trieste, Italy	Date of Grant:	July 11, 2006
Nature of Application: Equipment Description: Equipment Category:		Original GSM 850/1900MHz Module Category I	
Model Number(s)			
GE864-QUAD GE864-PY			
Conducted RF Power or Field Strength: Frequency Range: Bandwidth(s): Emission Designations: Antenna Information:		1.7 Watts and 0.36 Watts 824.2-848.8MHz and 1850.2-1909.8 MHz 290 KHz 290KGXW NA	
Test Lab: Cetecom S.A. Parque Tecnológico de Andaluci, C/Severo Ochoa 2, 29590 Campanillas, Malaga, Spain rorejas@cetecom.es Tel: 34-952-61-93-57			
Test Lab IC Site Number: IC-4621			
Notes: Power Output is ERP for Part 22 and EIRP for Part 24. The antenna(s) used for this transmitter must be installed to provide a separation distance of at least 20 cm from all persons and must not be co-located or operating in conjunction with any other antenna or transmitter. Installers and end-users must be provided with installation instructions and transmitter operating conditions for satisfying RF exposure compliance.			
Certification of equipment means only that the equipment met the requirements of the above noted specification(s). License applications, where applicable to use certified equipment, are acted on accordingly by the issuing office and will depend on the existing radio environment, service and location of operation. This certificate is issued on condition that the holder complies and will continue to comply with requirements and procedures issued by Industry Canada.			
ISSUED UNDER THE AUTHORITY OF THE MINISTER OF INDUSTRY			
 Kevin Mehaffey Manager, EMC Laboratory Printed: July 11, 2006			
<small>DOC-ICR001 3/11/2005</small>			



Telit GE864 and GC864 Product Description
80273ST10008a Rev. 17-2009-12-01

9.10. GC864-QUAD/PY: IC Equipment Authorization



GRANT OF EQUIPMENT CERTIFICATION

THE FOLLOWING EQUIPMENT HAS BEEN TESTED
AND CERTIFIED UNDER
INDUSTRY CANADA
RSS 132 ISSUE 1 PROVISIONAL AUG. 2002, RSS 133 ISSUE 3, JUNE 2005

CB Issued By: **CB**
MET Laboratories, Inc.
914 W. Patapsco Avenue
Baltimore, Maryland 21230
Laboratory Number: 2043

Equipment Certification is hereby issued to the Identified Certificate Holder and is VALID ONLY for the equipment identified herein.
La certification d'équipement est par ceci publiée au support identifié de certicate et est VALIDE SEULEMENT pour l'équipement identifié ci-dessus
NOT TRANSFERABLE / NON TRANSMISSIBLE

FILE/CERTIFICATE NUMBER: 081-07-2006-20414

CERTIFICATION NUMBER: IC: 5131A-GC864

Issued to/Delivré a:	Telit Communications S.p.A	Date of Grant:	July 28, 2006
Address:	Viale Stazione di Prosecco 5/B I-34010 Trieste, Italy		
Nature of Application/Nature d'Application:	Original		
Equipment Description/Genre de Matériel:	Quad-Band GSM/GPRS module		
Equipment Category/Catégorie de Matériel:	Category I		
Model Number(s)/Marque et Modele	GC864-QUAD GC864-PY		
Conducted RF Power or Field Strength/Puissance H.F.:	1.56 Watts(eirp) and 0.27 Watts(erp)		
Frequency Range/Bande de Fréquences:	824.2-848.8MHz and 1850.2-1909.8 MHz		
Bandwidth(s)/ largeurs de bande:	290 KHz		
Emission Designations/Genre D'Emission:	290KGXW		
Antenna Information/ l'information d'antenne:	N/A		

Test Lab: rorejas@cetecom.es Tel: 34-952-61-93-57
IC-4621

Notes: Power Output is ERP for Part 22 and EIRP for Part 24. The antenna(s) used for this transmitter must be installed to provide a separation distance of at least 20 cm from all persons and must not be co-located or operating in conjunction with any other antenna or transmitter. Installers and end-users must be provided with installation instructions and transmitter operating conditions for satisfying RF exposure compliance.

Certification of equipment means only that the equipment met the requirements of the above noted specification(s). License applications, where applicable to use certified equipment, are acted on accordingly by the issuing office and will depend on the existing radio environment, service and location of operation. This certificate is issued on condition that the holder complies and will continue to comply with requirements and procedures issued by Industry Canada.

L'homologation de matériel terminal signifie seulement qu'il est conforme aux exigences du cahier des charges mentionné ci-dessus. Les demandes de licence, le cas échéant en vue de l'utilisation de matériel certifié seront traitées en conséquence par le bureau chargé de délivrer les dites licences, en tenant compte du milieu radioélectrique ambiant, du service radio existant et de l'emplacement de la station. Le présent certificate est délivré à condition que le détenteur se conforme et continue à se conformer aux cahiers des charges et procédures sur les norms radioélectriques publiées par le ministère.

ISSUED UNDER THE AUTHORITY OF THE MINISTER OF INDUSTRY
DELIVRE AVEC L'AUTORISATION DU MINISTRE DES INDUSTRIES

 Kevin McKaffey
 Manager, EMC Laboratory
 Printed: July 28, 2006



DOC-ICR001 3/11/2005

10. SAFETY RECOMMENDATIONS

READ CAREFULLY

Be sure the use of this product is allowed in the country and in the environment required. The use of this product may be dangerous and has to be avoided in the following areas:

Where it can interfere with other electronic devices in environments such as hospitals, airports, aircrafts, etc

Where there is risk of explosion such as gasoline stations, oil refineries, etc

It is responsibility of the user to enforce the country regulation and the specific environment regulation.

Do not disassemble the product; any mark of tampering will compromise the warranty validity.

We recommend following the instructions of the hardware user guides for a correct wiring of the product. The product has to be supplied with a stabilized voltage source and the wiring has to be conforming to the security and fire prevention regulations.

The product has to be handled with care, avoiding any contact with the pins because electrostatic discharges may damage the product itself. Same cautions have to be taken for the SIM, checking carefully the instruction for its use. Do not insert or remove the SIM when the product is in power saving mode.

The system integrator is responsible of the functioning of the final product; therefore, care has to be taken to the external components of the module, as well as of any project or installation issue, because the risk of disturbing the GSM network or external devices or having impact on the security. Should there be any doubt, please refer to the technical documentation and the regulations in force.

Every module has to be equipped with a proper antenna with specific characteristics. The antenna has to be installed with care in order to avoid any interference with other electronic devices and has to guarantee a minimum distance from the body (20 cm). In case of this requirement cannot be satisfied, the system integrator has to assess the final product against the SAR regulation.



Telit GE864 and GC864 Product Description
80273ST10008a Rev. 17-2009-12-01

The European Community provides some Directives for the electronic equipments introduced on the market. All the relevant information's are available on the European Community website:

<http://europa.eu.int/comm/enterprise/rtte/dir99-5.htm>

The text of the Directive 99/05 regarding telecommunication equipments is available, while the applicable Directives (Low Voltage and EMC) are available at:

http://europa.eu.int/comm/enterprise/electr_equipment/index_en.htm



11. List of acronyms

ACM	Accumulated Call Meter
ASCII	American Standard Code for Information Interchange
AT	Attention commands
CB	Cell Broadcast
CBS	Cell Broadcasting Service
CCM	Call Control Meter
CLIP	Calling Line Identification Presentation
CLIR	Calling Line Identification Restriction
CMOS	Complementary Metal-Oxide Semiconductor
CR	Carriage Return
CSD	Circuit Switched Data
CTS	Clear To Send
DAI	Digital Audio Interface
DCD	Data Carrier Detected
DCE	Data Communications Equipment
DRX	Data Receive
DSR	Data Set Ready
DTA	Data Terminal Adaptor
DTE	Data Terminal Equipment
DTMF	Dual Tone Multi Frequency
DTR	Data Terminal Ready
EMC	Electromagnetic Compatibility
ETSI	European Telecommunications Equipment Institute
FTA	Full Type Approval (ETSI)
GPRS	General Radio Packet Service
GSM	Global System for Mobile communication
HF	Hands Free
IMEI	International Mobile Equipment Identity
IMSI	International Mobile Subscriber Identity
IRA	International Reference Alphabet
ITU	International Telecommunications Union
IWF	Inter-Working Function
LCD	Liquid Crystal Display
LED	Light Emitting Diode
LF	Linefeed
ME	Mobile Equipment
MMI	Man Machine Interface
MO	Mobile Originated



Telit GE864 and GC864 Product Description
80273ST10008a Rev. 17-2009-12-01

MS	Mobile Station
MT	Mobile Terminated
OEM	Other Equipment Manufacturer
PB	Phone Book
PDU	Protocol Data Unit
PH	Packet Handler
PIN	Personal Identity Number
PLMN	Public Land Mobile Network
PUCT	Price per Unit Currency Table
PUK	PIN Unblocking Code
RACH	Random Access Channel
RLP	Radio Link Protocol
RMS	Root Mean Square
RTS	Ready To Send
RI	Ring Indicator
RIL	Radio Interface Layer
SCA	Service Center Address
SIM	Subscriber Identity Module
SMD	Surface Mounted Device
SMS	Short Message Service
SMSC	Short Message Service Center
SS	Supplementary Service
TIA	Telecommunications Industry Association
UDUB	User Determined User Busy
USSD	Unstructured Supplementary Service Data

