

TEST REPORT

Equipment Under Test	: G83
FCC ID	: RI7G83
Model No.	: G83
Applicant	: DAI Telecom S.p.A.
Address of Applicant	: Via Stazione di Prosecco 5/B
Date of Receipt	: 2004.09.17
Date of Test(s)	: 2004.09.21-2004.09.22,2004.10.08
Date of Issue	: 2004.10.11

Standards:

**FCC OET Bulletin 65 supplement C,
ANSI/IEEE C95.1 , C95.3
IEEE 1528 2002**

In the configuration tested, the EUT complied with the standards specified above.

Remarks:

This report details the results of the testing carried out on one sample, the results contained in this test report do not relate to other samples of the same product. The manufacturer should ensure that all products in series production are in conformity with the product sample detailed in this report.

This report may only be reproduced and distributed in full. If the product in this report is used in any configuration other than that detailed in the report, the manufacturer must ensure the new system complies with all relevant standards. Any mention of SGS Taiwan E&E Services or testing done by SGS Taiwan E&E Services in connection with distribution or use of the product described in this report must be approved by SGS Taiwan E&E Services in writing.

Tested by : Dikin Yang Date : 2004.10.11

Approved by : Robert Chang Date : 2004.10.11

Contents

1. General Information	
1.1 Testing Laboratory.....	3
1.2 Details of Applicant.....	3
1.3 Description of EUT(s).....	3
1.4 Test Environment.....	4
1.5 Operation description.....	4
1.6 The SAR Measurement System.....	4
1.7 System Components.....	6
1.8 SAR System Verification.....	7
1.9 Tissue Simulant Fluid for the Frequency Band	8
1.10 Test Standards and Limits.....	9
2. Summary of Results	11
3. Instruments List	12
4. Measurements	13
4.1 Right-head, cheek, lowest channel.....	13
4.2 Right-head, cheek, middle channel.....	14
4.3 Right-head, cheek, highest channel.....	15
4.4 Left-head, cheek, lowest channel.....	16
4.5 Left-head, cheek, middle channel.....	17
4.6 Left-head, cheek, highest channel.....	18
4.7 Right head, tilt 15°, lowest channel.....	19
4.8 Right head, tilt 15°, middle channel.....	20
4.9 Right head, tilt 15°, highest channel.....	21
4.10 Left head, tilt 15°, lowest channel.....	22
4.11 Left head, tilt 15°, middle channel.....	23
4.12 Left head, tilt 15°, highest channel.....	24
4.13 Body-Worn , lowest channel.....	25
4.14 Body-Worn , middle channel.....	26
4.15 Body-Worn , highest channel.....	27
4.16 System Verification of GSM 1900MHz Head.....	28
4.17 System Verification of GSM 1900MHz Muscle.....	30
APPENDIX	
1. Photographs of Test Setup.....	31
2. Photographs of EUT.....	34
2. Photographs of the Battery.....	36
3. Probe Calibration certificate.....	37
4. Uncertainty Analysis.....	41
5. Phantom description.....	42
6. System Validation from Original equipment supplier.....	43

1. General Information

1.1 Testing Laboratory

SGS Taiwan Ltd.
 1F, No. 134, Wukung Road, Wuku industrial zone
 Taipei county , Taiwan , R.O.C.
 Telephone : +886-2-2299-3279
 Fax : +886-2-2298-2698
 Internet : <http://www.sgs.com.tw>

1.2 Details of Applicant

Name : DAI Telecom S.p.A.
 V.A.T : 03711600266
 Address : Via Stazione di Prosecco 5/B
 City : Trieste
 Postal code : 34010
 Country : Italy
 Telephone : +39 0404 192 111
 Contact Person : Andrea Fragiacomò
 E-mail : andrea.fragiacomo@telit.net

1.3 Description of EUT(s)

EUT Type	G83	
Model	G83	
Mode of Operation	GSM/GPRS 900/1800/1900	
FCC ID	RI7G83	
Modulation Mode	GMSK	
Maximum RF Conducted Power	28.6 dbm	
Duty Cycle	1/8.3 (GSM)	1/4 (GPRS) Worst Case
TX Frequency range	1850-1910 MHz	

Antenna Type	Embedded
Battery Type	3.7V Lithium-Ion
Exposure environment	Uncontrolled exposure
Max. SAR Measured (1g)	0.304 W/kg (at Right-Head Tilt Channel 810) 0.233 W/kg (at Body-worn Channel 512)

1.4 Test Environment

Ambient temperature : 22.3° C

Tissue Simulating Liquid : 21.8° C

Relative Humidity : 64 %

1.5 Operation description

The device was controlled by using a Universal Radio Communication Tester (CMU 200). Communication between the device and the tester was established by air link. Measurements were performed on the lowest, middle and highest channels of the operating band. The phone was set to maximum power level during all tests and at the beginning of each test the battery was fully charged.

The DASY4 system measures power drift during SAR testing by comparing e-field in the same location at the beginning and at the end of measurement.

1.6 The SAR Measurement System

A photograph of the SAR measurement System is given in Fig. a. This SAR Measurement System uses a Computer-controlled 3-D stepper motor system (Speag Dasy 4 professional system). A Model ET3DV6 1760E-field probe is used to determine the internal electric fields. The SAR can be obtained from the equation $SAR = \sigma (|E_i|^2) / \rho$ where σ and ρ are the conductivity and mass density of the tissue-simulant.

The DASY4 system for performing compliance tests consists of the following items:

- A standard high precision 6-axis robot (Stabile RX family) with controller, teach pendant and software. An arm extension for accommodating the data acquisition electronics (DAE).
- A dosimetric probe, i.e., an isotropic E-field probe optimized and calibrated for usage in

tissue simulating liquid. The probe is equipped with an optical surface detector system.

- A data acquisition electronics (DAE) which performs the signal amplification, signal multiplexing, AD-conversion, offset measurements, mechanical surface detection, collision detection, etc. The unit is battery powered with standard or rechargeable batteries. The signal is optically transmitted to the EOC.

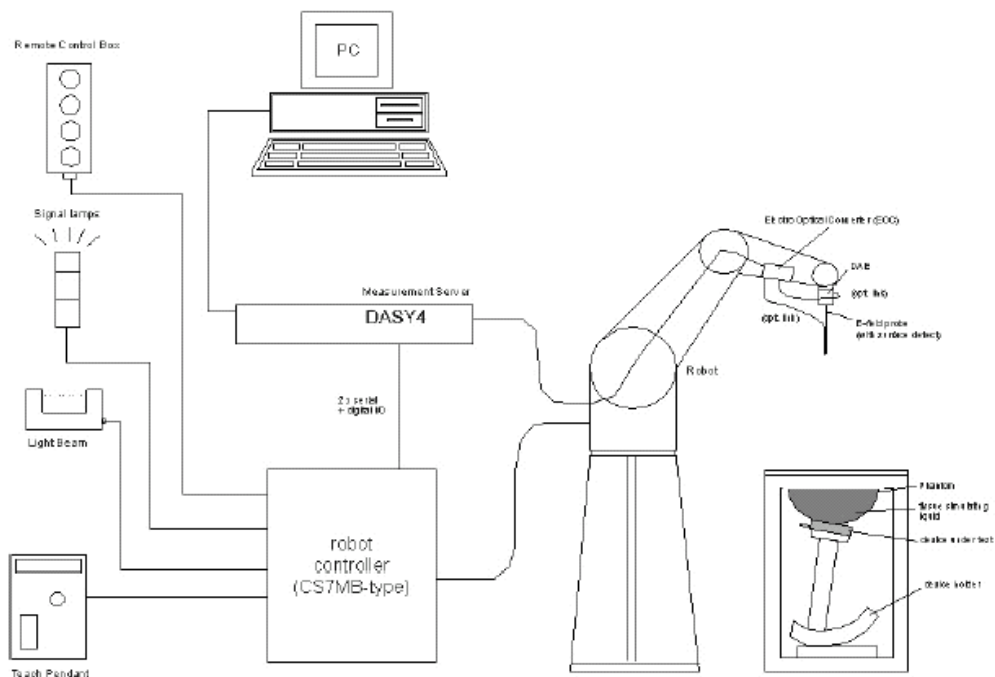

Fig. a The microwave circuit arrangement used for SAR system verification

- The Electro-optical converter (EOC) performs the conversion between optical and electrical of the signals for the digital communication to the DAE and for the analog signal from the optical surface detection. The EOC is connected to the measurement server.
- The function of the measurement server is to perform the time critical tasks such as signal filtering, control of the robot operation and fast movement interrupts.
- A probe alignment unit which improves the (absolute) accuracy of the probe positioning.
- A computer operating Windows 2000 or Windows XP.
- DASY4 software.
- Remote control with teach pendant and additional circuitry for robot safety such as warning lamps, etc.

- The SAM twin phantom enabling testing left-hand and right-hand usage.
- The device holder for handheld mobile phones.
- Tissue simulating liquid mixed according to the given recipes.
- Validation dipole kits allowing to validate the proper functioning of the system.

1.7 System Components

ET3DV6 E-Field Probe

Construction:	Symmetrical design with triangular core Built-in shielding against static charges PEEK enclosure material (resistant to organic solvents, e.g. glycol)
Calibration:	In air from 10 MHz to 2.5 GHz In brain simulating tissue at frequencies of 1900 MHz (accuracy $\pm 8\%$)
Frequency:	10 MHz to >6 GHz; Linearity: ± 0.2 dB (30 MHz to 3 GHz)

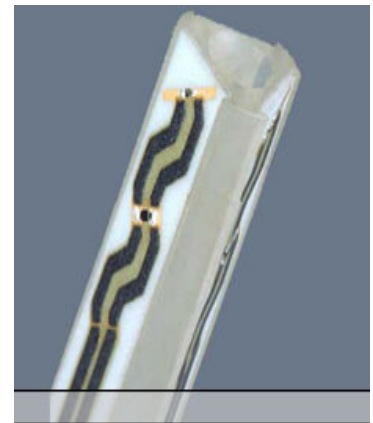

ET3DV6 E-Field Probe

Directivity:	± 0.2 dB in brain tissue (rotation around probe axis) ± 0.4 dB in brain tissue (rotation normal to probe axis)
Dynamic Range:	5 μ W/g to >100 mW/g; Linearity: ± 0.2 dB
Surface. Detect:	± 0.2 mm repeatability in air and clear liquids over diffuse reflecting surfaces
Dimensions:	Overall length: 330 mm Tip length: 16 mm Body diameter: 12 mm Tip diameter: 6.8 mm Distance from probe tip to dipole centers: 2.7 mm
Application:	General dosimetry up to 3 GHz Compliance tests of mobile phone

SAM PHANTOM V4.0C

Construction:	The shell corresponds to the specifications of the Specific Anthropomorphic Mannequin (SAM) phantom defined in IEEE 1528-200X, CENELEC 50361 and IEC 62209. It enables the dosimetric evaluation of left and right hand phone usage as well as body mounted usage at the flat phantom region. A cover prevents
---------------	--

evaporation of the liquid. Reference markings on the phantom allow the complete setup of all predefined phantom positions and measurement grids by manually teaching three points with the robot.

Shell Thickness: 2 ± 0.2 mm
 Filling Volume: Approx. 25 liters
 Dimensions: Height: 810 mm;
 Length: 1000 mm;
 Width: 500 mm



DEVICE HOLDER

Construction In combination with the Twin SAM Phantom V4.0/V4.0C or Twin SAM, the Mounting Device (made from POM) enables the rotation of the mounted transmitter in spherical coordinates, whereby the rotation point is the ear opening. The devices can be easily and accurately positioned according to IEC, IEEE, CENELEC, FCC or other specifications. The device holder can be locked at different phantom locations (left head, right head, flat phantom).



Device Holder

1.8 SAR System Verification

The microwave circuit arrangement for system verification is sketched in Fig. b. The daily system accuracy verification occurs within the flat section of the SAM phantom. A SAR measurement was performed to see if the measured SAR was within $\pm 10\%$ from the target SAR values. These tests were done at 1900MHz. The tests were conducted on the same days as the measurement of the DUT. The obtained results from the system accuracy verification are displayed in the table 1 (SAR values are normalized to 1W forward power delivered to the dipole). During the tests, the ambient temperature of the laboratory was in the range 22.3°C , the relative humidity was in the range 64% and the liquid depth above the ear reference points was above 15 cm in all the cases. It is seen that the system is operating within its specification, as the results are within acceptable tolerance of the reference values.

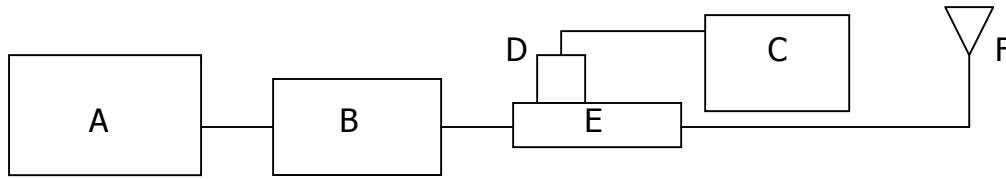
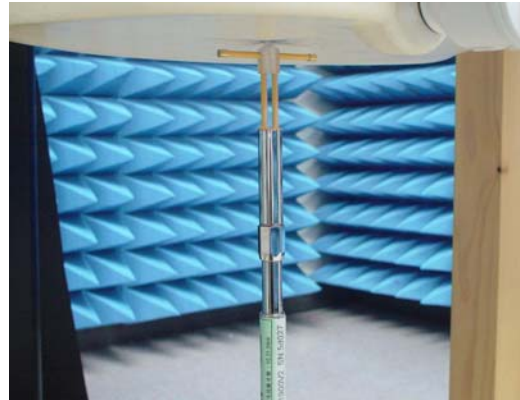

Fig.b The microwave circuit arrangement used for SAR system verification

- A. Agilent Model 8648D Signal Generator
- B. Mini circuits Model ZHL-42 Amplifier
- C. Agilent Model E4416A Power Meter
- D. Agilent Model 8481H Power Sensor
- E. Agilent Model 777D(1900MHz)
Dual directional coupling
- F. Reference dipole antenna



Photograph of the 1900MHz dipole Antenna

Validation Kit	Frequency	Target SAR 1g (250mW)	Target SAR 10g (250mW)	Measured SAR 1g	Measured SAR 10g	Measured date
DT3DV6 S/N :1760	1900 MHz (Head)	10.5 m W/g	5.44 m W/g	10 m W/g	5.21 m W/g	2004-09-21
DT3DV6 S/N :1760	1900 MHz (Body)	10.7 m W/g	5.6 m W/g	10.2 m W/g	5.31 m W/g	2004-09-22
DT3DV6 S/N :1760	1900 MHz (Head)	10.7 m W/g	5.6 m W/g	10 m W/g	5.2 m W/g	2004-10-08

Table 1. Results system validation

1.9 Tissue Simulant Fluid for the Frequency Band

F (Mhz)	Tissue type	Limits/ Measured	Dielectric Parameters		
			ρ	σ (S/m)	Simulated Tissue Temp($^{\circ}$ C)
1900	Head	Measured, 2004.09.21	39.58	1.44	21.7
		Recommended Limits	38-42	1.33-1.47	20-24
		Measured, 2004.10.08	39.68	1.441	21.8
		Recommended Limits	38-42	1.33-1.47	20-24
	Body	Measured, 2004.09.22	53.19	1.557	21.7
		Recommended Limits	50.6-56	1.44-1.6	20-24

Table 2. Dielectric Parameters of Tissue Simulant Fluid

The dielectric properties for this body-simulant fluid were measured by using the HP Model 85070D Dielectric Probe (rates frequency band 200 MHz to 20 GHz) in conjunction with HP 8753D Network Analyzer(30 KHz-6000 MHz) by using a procedure detailed in Section V.

All dielectric parameters of tissue simulates were measured within 24 hours of SAR measurements. The depth of the tissue simulant in the ear reference point of the phantom was $15\text{cm}\pm 5\text{mm}$ during all tests. (Fig .2 & Fig.3)

The composition of the brain tissue simulating liquid for 1900 MHz is:

Ingredient	1900Mhz(Head)	1900Mhz(Body)
DGMBE	444.52 g	300.67
Water	552.42 g	716.56
Sale	3.06 g	4.0
Total amount	1 L (1.0kg)	1 L (1.0kg)

Table 3. Recipes for 1900MHz tissue simulating liquid

1.10 Test Standards and Limits

According to FCC 47CFR §2.1093(d) The limits to be used for evaluation are based generally on criteria published by the American National Standards Institute (ANSI) for localized specific absorption rate ("SAR") in Section 4.2 of "IEEE Standard for Safety Levels with Respect to Human Exposure to Radio Frequency Electromagnetic Fields, 3 kHz to 300 GHz," ANSI/IEEE C95.1-1992, Copyright 1992 by the Institute of Electrical and Electronics Engineers, Inc., New York, New York 10017. These criteria for SAR evaluation are similar to those recommended by the National Council on Radiation Protection and Measurements (NCRP) in "Biological Effects and Exposure Criteria for Radiofrequency Electromagnetic Fields," NCRP Report No. 86, Section 17.4.5. Copyright NCRP, 1986, Bethesda, Maryland 20814. SAR is a measure of the rate of energy absorption due to exposure to an RF transmitting source. SAR values have been related to threshold levels for potential biological hazards. The criteria to be used are specified in paragraphs (d)(1) and (d)(2) of this section and shall apply for portable devices transmitting in the frequency range from 100 kHz to 6 GHz. Portable devices that transmit at frequencies above 6 GHz are to be evaluated in terms of the MPE limits specified in § 1.1310 of this chapter. Measurements and calculations to demonstrate compliance with MPE field strength or power density limits for devices operating above 6 GHz should be made at a minimum distance of 5 cm from the radiating source.

(1) Limits for Occupational/Controlled exposure: 0.4 W/kg as averaged over the whole-body and spatial peak SAR not exceeding 8 W/kg as averaged over any 1 gram of

tissue (defined as a tissue volume in the shape of a cube). Exceptions are the hands, wrists, feet and ankles where the spatial peak SAR shall not exceed 20 W/kg, as averaged over an 10 grams of tissue (defined as a tissue volume in the shape of a cube). Occupational/Controlled limits apply when persons are exposed as a consequence of their employment provided these persons are fully aware of and exercise control over their exposure. Awareness of exposure can be accomplished by use of warning labels or by specific training or education through appropriate means, such as an RF safety program in a work environment.

(2) Limits for General Population/Uncontrolled exposure: 0.08 W/kg as averaged over the whole-body and spatial peak SAR not exceeding 1.6 W/kg as averaged over any 1 gram of tissue (defined as a tissue volume in the shape of a cube). Exceptions are the hands, wrists, feet and ankles where the spatial peak SAR shall not exceed 4 W/kg, as averaged over any 10 grams of tissue (defined as a tissue volume in the shape of a cube). General Population/Uncontrolled limits apply when the general public may be exposed, or when persons that are exposed as a consequence of their employment may not be fully aware of the potential for exposure or do not exercise control over their exposure. Warning labels placed on consumer devices such as cellular telephones will not be sufficient reason to allow these devices to be evaluated subject to limits for occupational/controlled exposure in paragraph (d)(1) of this section.(Table .4)

Human Exposure	Uncontrolled Environment General Population	Controlled Environment Occupational
Spatial Peak SAR (Brain)	1.60 m W/g	8.00 m W/g
Spatial Average SAR (Whole Body)	0.08 m W/g	0.40 m W/g
Spatial Peak SAR (Hands/Feet/Ankle/Wrist)	4.00 m W/g	20.00 m W/g

Table .4 RF exposure limits

Notes:

1. Uncontrolled environments are defined as locations where there is potential exposure of individuals who have no knowledge or control of their potential exposure.
2. Controlled environments are defined as locations where there is potential exposure of individuals who have knowledge of their potential exposure and can exercise control over their exposure.

2.Summary of Results

Right Head (Cheek Position)						
Frequency	Channel	MHz	Conducted Output Power(Peak)	Measured(W/kg) 1g/10g	Amb. Temp[°C]	Liquid Temp[°C]
1900 MHz	512	1850.2	28.3 dbm	0.251/0.139	22.3	21.7
	661	1880	28.6 dbm	0.262/0.145	22.3	21.7
	810	1909.8	28.5 dbm	0.275/0.15	22.3	21.7
Left Head (Cheek Position)						
Frequency	Channel	MHz	Conducted Output Power(Peak)	Measured(W/kg) 1g/10g	Amb. Temp[°C]	Liquid Temp[°C]
1900 MHz	512	1850.2	28.3 dbm	0.239/0.142	22.2	21.7
	661	1880	28.6 dbm	0.259/0.152	22.3	21.7
	810	1909.8	28.5 dbm	0.286/0.17	22.3	21.8
Right Head (15° Tilt Position)						
Frequency	Channel	MHz	Conducted Output Power(Peak)	Measured(W/kg) 1g/10g	Amb. Temp[°C]	Liquid Temp[°C]
1900 MHz	512	1850.2	28.3 dbm	0.281/0.146	22.3	21.8
	661	1880	28.6 dbm	0.3/0.155	22.3	21.8
	810	1909.8	28.5 dbm	0.304/0.159	22.3	21.8
Left Head (15° Tilt Position)						
Frequency	Channel	MHz	Conducted Output Power(Peak)	Measured(W/kg) 1g/10g	Amb. Temp[°C]	Liquid Temp[°C]
1900 MHz	512	1850.2	28.3 dbm	0.252/0.143	22.2	21.7
	661	1880	28.6 dbm	0.267/0.151	22.3	21.8
	810	1909.8	28.5 dbm	0.289/0.165	22.2	21.7
Body Worn for Headset						
Frequency	Channel	MHz	Conducted Output Power(Peak)	Measured(W/kg) 1g/10g	Amb. Temp[°C]	Liquid Temp[°C]
1900 MHz	512	1850.2	28.3 dbm	0.233/0.142	22.2	21.7
	661	1880	28.6 dbm	0.223/0.136	22.2	21.7
	810	1909.8	28.5 dbm	0.196/0.12	22.2	21.7

Note:

SAR measurement results for the Telit G83 Mobile Phone at maximum output power.

3. Instruments List

Manufacturer	Device	Type	IMEI number	Date of last calibration
Schmid & Partner Engineering AG	Dosimetric E-Field Probe	ET3DV6	1760	Feb.17.2004
Schmid & Partner Engineering AG	1900 MHz System Validation Dipole	D1900V2	5d027	Feb.17.2004
Schmid & Partner Engineering AG	Data acquisition Electronics	DAE3	547	Feb.10.2004
Schmid & Partner Engineering AG	Software	DASY 4 V4.3c Build 22	---	Calibration isn't necessary
Schmid & Partner Engineering AG	Phantom	SAM	---	Calibration isn't necessary
Agilent	Network Analyzer	8753D	3410A05547	Jun.03.2004
Agilent	Dielectric Probe Kit	85070D	US01440168	Calibration isn't necessary
Agilent	Dual-directional coupler	777D 778D	50114 50313	Jul.27.2004 Jul.27.2004
Agilent	RF Signal Generator	8648D	3847M00432	Feb.09.2004
Agilent	Power Sensor	8481H	MY41091361	May.24.2004

4. Measurements

Right-Head Cheek CH512

Date/Time: 10/08/04 15:59:05

DUT: TELIT G83; Type: Embedded; IMEI: 350166000084611

Program: GSM 1900MHZ

Communication System: GSM 1900; Frequency: 1850.2 MHz; Duty Cycle: 1:8.3

Medium: Head 1900MHz Medium parameters used (interpolated): $f = 1850.2$ MHz; $\sigma = 1.34$ mho/m; $\epsilon_r = 39.4$; $\rho = 1000$ kg/m³

Phantom section: Right Section

DASY4 Configuration:

- Probe: ET3DV6 - SN1760; ConvF(5.13, 5.13, 5.13); Calibrated: 2004/2/17
- Sensor-Surface: 4mm (Mechanical And Optical Surface Detection)
- Electronics: DAE3 Sn547; Calibrated: 2004/2/10
- Phantom: SAM 12; Type: SAM 4.0; Serial: TP:1150
- Measurement SW: DASY4, V4.3 Build 22; Postprocessing SW: SEMCAD, V1.8 Build 127

GSM 1900 Right-Cheek/Area Scan (51x101x1): Measurement grid: dx=15mm, dy=15mm

Maximum value of SAR (interpolated) = 0.281 mW/g

GSM 1900 Right-Cheek/Zoom Scan (7x7x7)/Cube 0: Measurement grid: dx=5mm, dy=5mm, dz=5mm

Reference Value = 11.8 V/m; Power Drift = -0.002 dB

Peak SAR (extrapolated) = 0.454 W/kg

SAR(1 g) = 0.251 mW/g; SAR(10 g) = 0.139 mW/g

Maximum value of SAR (measured) = 0.275 mW/g

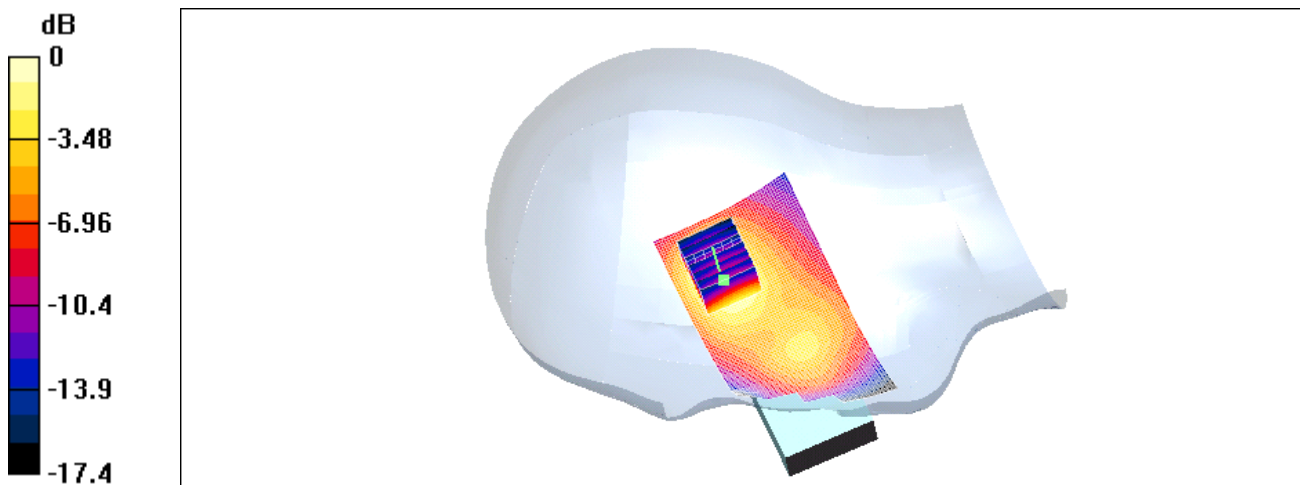

Right-Head Cheek CH661

DUT: TELIT G83; Type: Embedded; IMEI: 350166000084611

Program: GSM 1900MHZ

Communication System: GSM 1900; Frequency: 1880 MHz; Duty Cycle: 1:8.3

Medium: Head 1900MHz Medium parameters used (interpolated): $f = 1880$ MHz; $\sigma = 1.4$ mho/m; $\epsilon_r = 39.4$; $\rho = 1000$ kg/m³

Phantom section: Right Section

DASY4 Configuration:

- Probe: ET3DV6 - SN1760; ConvF(5.13, 5.13, 5.13); Calibrated: 2004/2/17
- Sensor-Surface: 4mm (Mechanical And Optical Surface Detection)
- Electronics: DAE3 Sn547; Calibrated: 2004/2/10
- Phantom: SAM 12; Type: SAM 4.0; Serial: TP:1150
- Measurement SW: DASY4, V4.3 Build 22; Postprocessing SW: SEMCAD, V1.8 Build 127

GSM 1900 Right-Cheek/Area Scan (51x101x1): Measurement grid: dx=15mm, dy=15mm

Maximum value of SAR (interpolated) = 0.293 mW/g

GSM 1900 Right-Cheek/Zoom Scan (7x7x7)/Cube 0: Measurement grid: dx=5mm, dy=5mm, dz=5mm

Reference Value = 11.8 V/m; Power Drift = -0.002 dB

Peak SAR (extrapolated) = 0.474 W/kg

SAR(1 g) = 0.262 mW/g; SAR(10 g) = 0.145 mW/g

Maximum value of SAR (measured) = 0.287 mW/g

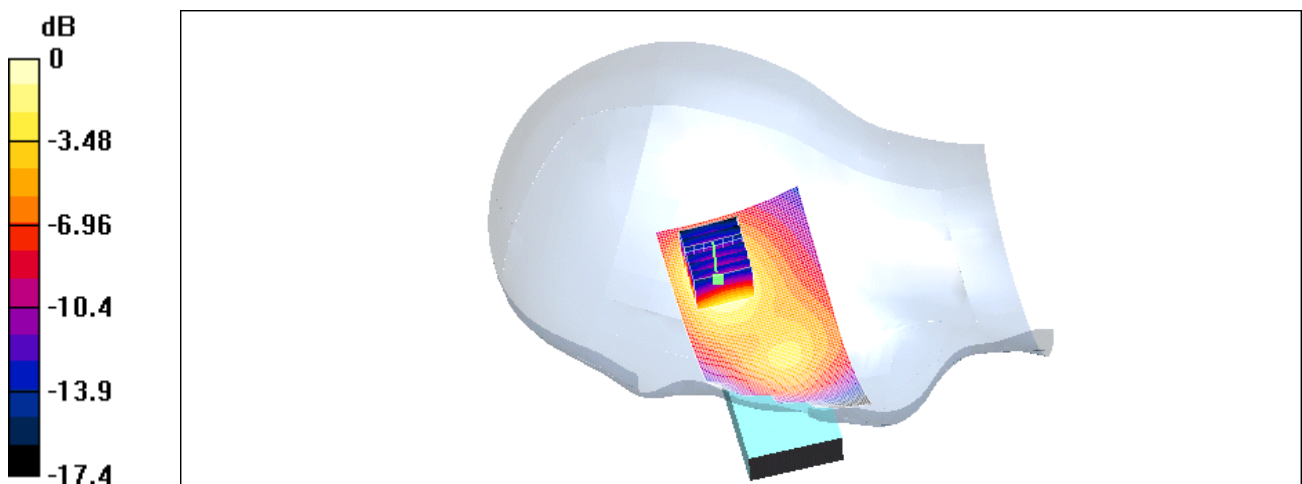

0 dB = 0.287mW/g

Right-Head Cheek CH810

DUT: TELIT G83; Type: Embedded; IMEI: 350166000084611

Program: GSM 1900MHZ

Communication System: GSM 1900; Frequency: 1909.8 MHz; Duty Cycle: 1:8.3

Medium: Head 1900MHz ($\sigma = 1.45412$ mho/m, $\epsilon_r = 39.4901$, $\rho = 1000$ kg/m³)

Phantom section: Right Section

DASY4 Configuration:

- Probe: ET3DV6 - SN1760; ConvF(5.1, 5.1, 5.1); Calibrated: 2004/2/17
- Sensor-Surface: 4mm (Mechanical And Optical Surface Detection)
- Electronics: DAE3 Sn547; Calibrated: 2004/2/10
- Phantom: SAM 12; Type: SAM 4.0; Serial: TP:1150
- Measurement SW: DASY4, V4.1 Build 47; Postprocessing SW: SEMCAD, V1.6 Build 115

GSM 1900 Right-Cheek/Area Scan (51x101x1): Measurement grid: dx=15mm, dy=15mm

Reference Value = 11.8 V/m

Power Drift = -0.002 dB

Maximum value of SAR = 0.301 mW/g

GSM 1900 Right-Cheek/Zoom Scan (7x7x7)/Cube 0: Measurement grid: dx=5mm, dy=5mm, dz=5mm

Peak SAR (extrapolated) = 0.492 W/kg

SAR(1 g) = 0.275 mW/g; SAR(10 g) = 0.15 mW/g

Reference Value = 11.8 V/m

Power Drift = -0.002 dB

Maximum value of SAR = 0.298 mW/g

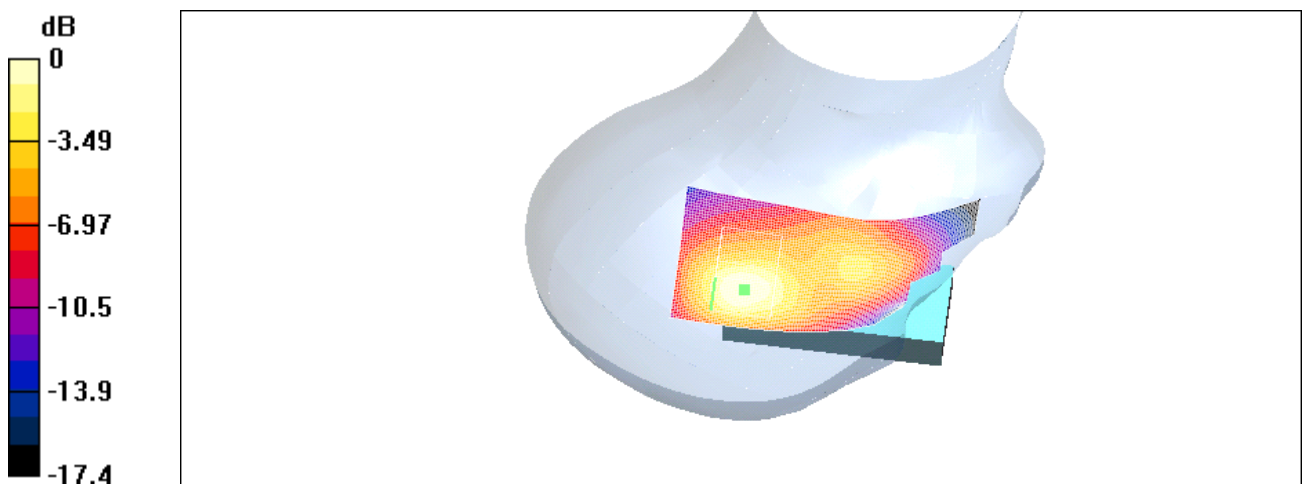

0 dB = 0.298mW/g

Left-Head Cheek CH512

DUT: TELIT G83; Type: Embedded; IMEI: 350166000084611

Program: GSM 1900MHZ

Communication System: GSM 1900; Frequency: 1850.2 MHz; Duty Cycle: 1:8.3

Medium: Head 1900MHz ($\sigma = 1.3647$ mho/m, $\epsilon_r = 39.1801$, $\rho = 1000$ kg/m³)

Phantom section: Left Section

DASY4 Configuration:

- Probe: ET3DV6 - SN1760; ConvF(5.13, 5.13, 5.13); Calibrated: 2004/2/17
- Sensor-Surface: 4mm (Mechanical And Optical Surface Detection)
- Electronics: DAE3 Sn547; Calibrated: 2004/2/10
- Phantom: SAM 12; Type: SAM 4.0; Serial: TP:1150
- Measurement SW: DASY4, V4.1 Build 47; Postprocessing SW: SEMCAD, V1.6 Build 115

GSM 1900 Left-Cheek/Area Scan (51x101x1): Measurement grid: dx=15mm, dy=15mm

Reference Value = 13.6 V/m

Power Drift = 0.04 dB

Maximum value of SAR = 0.258 mW/g

GSM 1900 Left-Cheek/Zoom Scan (7x7x7)/Cube 0: Measurement grid: dx=5mm, dy=5mm, dz=5mm

Peak SAR (extrapolated) = 0.379 W/kg

SAR(1 g) = 0.239 mW/g; SAR(10 g) = 0.142 mW/g

Reference Value = 13.6 V/m

Power Drift = 0.04 dB

Maximum value of SAR = 0.258 mW/g

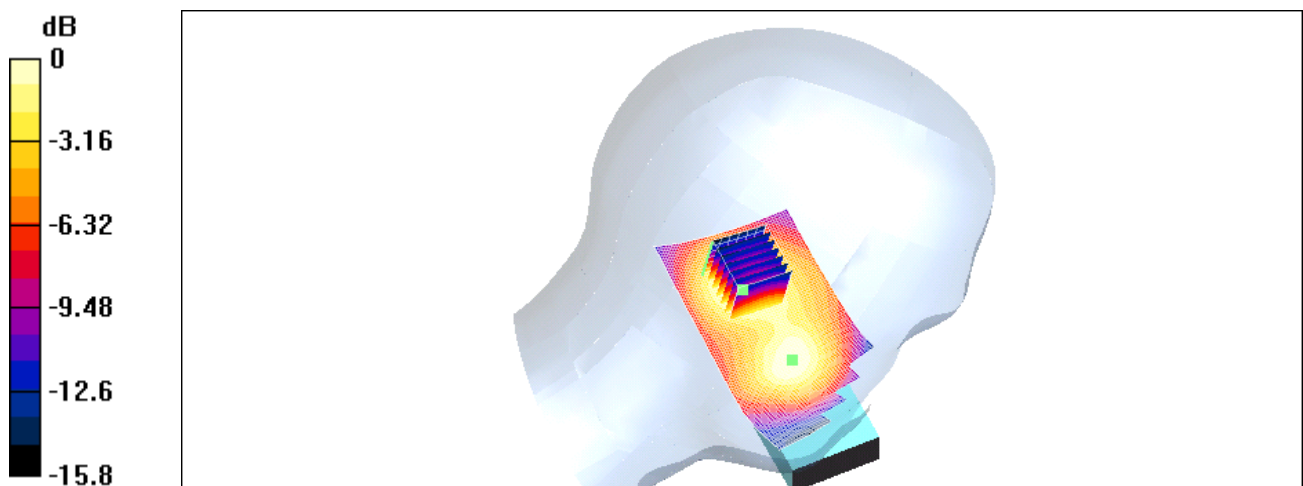

0 dB = 0.258mW/g

Left-Head Cheek CH661

DUT: TELIT G83; Type: Embedded; IMEI: 350166000084611

Program: GSM 1900MHZ

Communication System: GSM 1900; Frequency: 1880 MHz; Duty Cycle: 1:8.3

Medium: Head 1900MHz ($\sigma = 1.42002$ mho/m, $\epsilon_r = 39.2947$, $\rho = 1000$ kg/m³)

Phantom section: Left Section

DASY4 Configuration:

- Probe: ET3DV6 - SN1760; ConvF(5.13, 5.13, 5.13); Calibrated: 2004/2/17
- Sensor-Surface: 4mm (Mechanical And Optical Surface Detection)
- Electronics: DAE3 Sn547; Calibrated: 2004/2/10
- Phantom: SAM 12; Type: SAM 4.0; Serial: TP:1150
- Measurement SW: DASY4, V4.1 Build 47; Postprocessing SW: SEMCAD, V1.6 Build 115

GSM 1900 Left-Cheek/Area Scan (51x101x1): Measurement grid: dx=15mm, dy=15mm

Reference Value = 13.7 V/m

Power Drift = 0.005 dB

Maximum value of SAR = 0.28 mW/g

GSM 1900 Left-Cheek/Zoom Scan (7x7x7)/Cube 0: Measurement grid: dx=5mm, dy=5mm, dz=5mm

Peak SAR (extrapolated) = 0.417 W/kg

SAR(1 g) = 0.259 mW/g; SAR(10 g) = 0.152 mW/g

Reference Value = 13.7 V/m

Power Drift = 0.005 dB

Maximum value of SAR = 0.281 mW/g

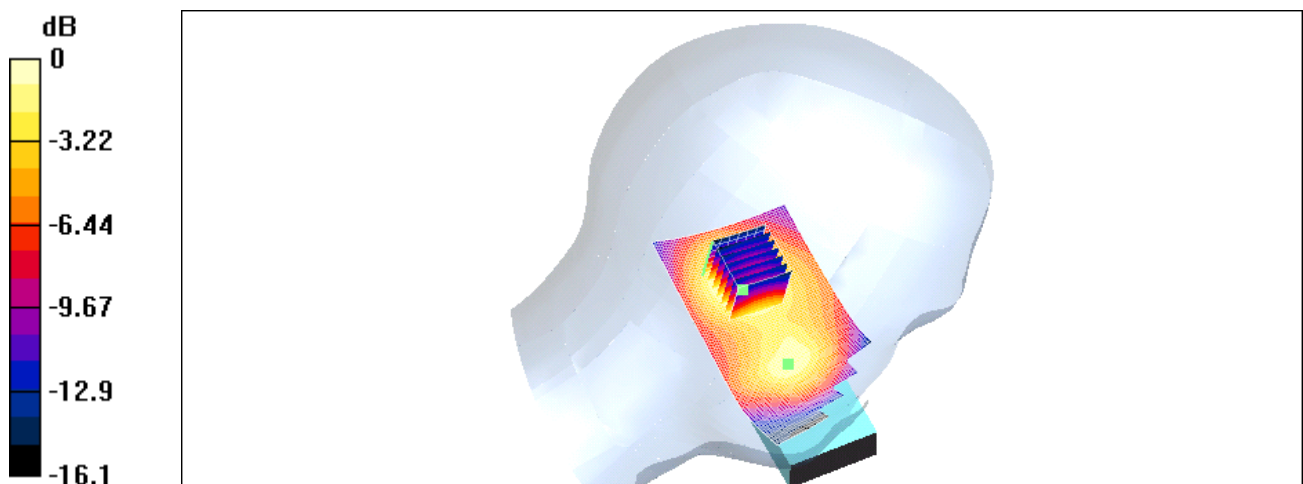

0 dB = 0.281mW/g

Left-Head Cheek CH810

DUT: TELIT G83; Type: Embedded; IMEI: 350166000084611

Program: GSM 1900MHZ

Communication System: GSM 1900; Frequency: 1909.8 MHz; Duty Cycle: 1:8.3

Medium: Head 1900MHz ($\sigma = 1.45412$ mho/m, $\epsilon_r = 39.4901$, $\rho = 1000$ kg/m³)

Phantom section: Left Section

DASY4 Configuration:

- Probe: ET3DV6 - SN1760; ConvF(5.1, 5.1, 5.1); Calibrated: 2004/2/17
- Sensor-Surface: 4mm (Mechanical And Optical Surface Detection)
- Electronics: DAE3 Sn547; Calibrated: 2004/2/10
- Phantom: SAM 12; Type: SAM 4.0; Serial: TP:1150
- Measurement SW: DASY4, V4.1 Build 47; Postprocessing SW: SEMCAD, V1.6 Build 115

GSM 1900 Left-Cheek/Area Scan (51x101x1): Measurement grid: dx=15mm, dy=15mm

Reference Value = 13.9 V/m

Power Drift = -0.04 dB

Maximum value of SAR = 0.315 mW/g

GSM 1900 Left-Cheek/Zoom Scan (7x7x7)/Cube 0: Measurement grid: dx=5mm, dy=5mm, dz=5mm

Peak SAR (extrapolated) = 0.44 W/kg

SAR(1 g) = 0.286 mW/g; SAR(10 g) = 0.17 mW/g

Reference Value = 13.9 V/m

Power Drift = -0.04 dB

Maximum value of SAR = 0.311 mW/g

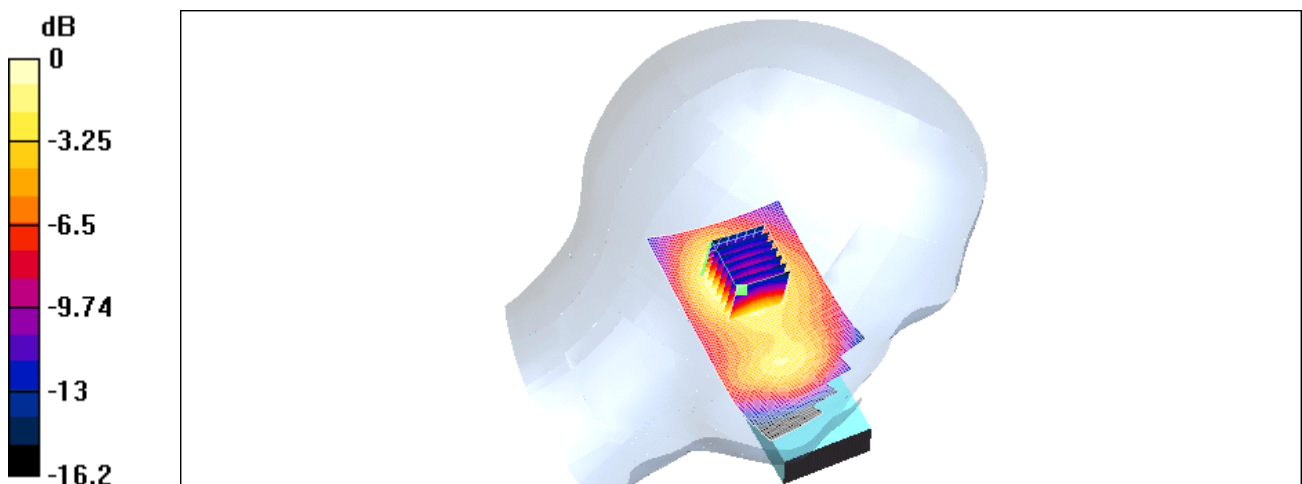

0 dB = 0.311mW/g

Right-Head Tilt CH512

DUT: TELIT G83; Type: Embedded; IMEI: 350166000084611

Program: GSM 1900MHZ

Communication System: GSM 1900; Frequency: 1850.2 MHz; Duty Cycle: 1:8.3

Medium: Head 1900MHz ($\sigma = 1.3647$ mho/m, $\epsilon_r = 39.1801$, $\rho = 1000$ kg/m³)

Phantom section: Right Section

DASY4 Configuration:

- Probe: ET3DV6 - SN1760; ConvF(5.13, 5.13, 5.13); Calibrated: 2004/2/17
- Sensor-Surface: 4mm (Mechanical And Optical Surface Detection)
- Electronics: DAE3 Sn547; Calibrated: 2004/2/10
- Phantom: SAM 12; Type: SAM 4.0; Serial: TP:1150
- Measurement SW: DASY4, V4.1 Build 47; Postprocessing SW: SEMCAD, V1.6 Build 115

GSM 1900 Right-Tilt/Area Scan (51x101x1): Measurement grid: dx=15mm, dy=15mm

Reference Value = 12.7 V/m

Power Drift = 0.03 dB

Maximum value of SAR = 0.301 mW/g

GSM 1900 Right-Tilt/Zoom Scan (7x7x7)/Cube 0: Measurement grid: dx=5mm, dy=5mm, dz=5mm

Peak SAR (extrapolated) = 0.503 W/kg

SAR(1 g) = 0.281 mW/g; SAR(10 g) = 0.146 mW/g

Reference Value = 12.7 V/m

Power Drift = 0.03 dB

Maximum value of SAR = 0.312 mW/g

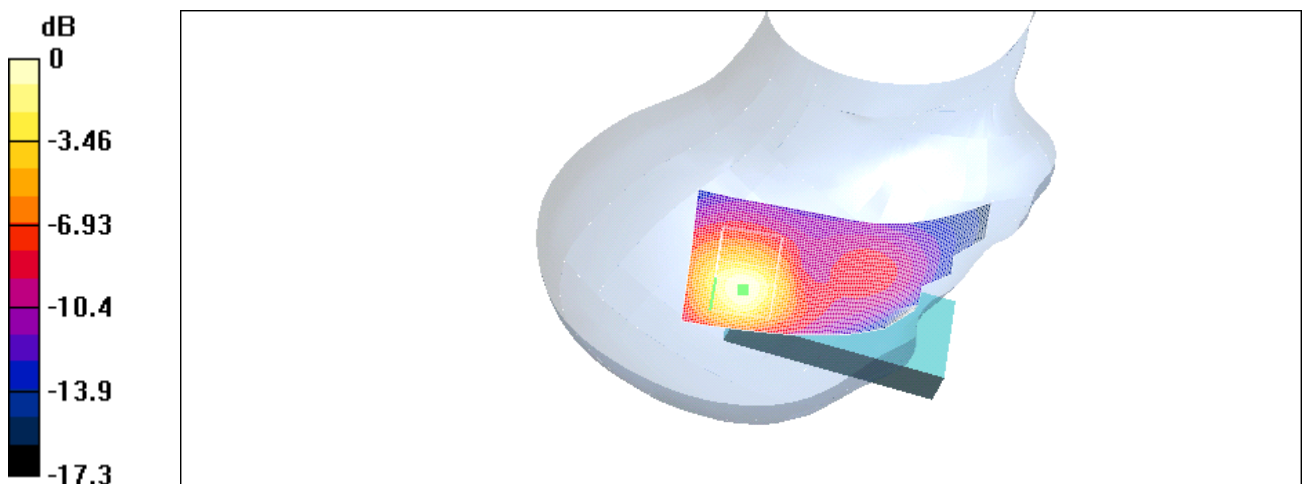

0 dB = 0.312mW/g

Right-Head Tilt CH661

DUT: TELIT G83; Type: Embedded; IMEI: 350166000084611

Program: GSM 1900MHZ

Communication System: GSM 1900; Frequency: 1880 MHz; Duty Cycle: 1:8.3

Medium: Head 1900MHz ($\sigma = 1.42002$ mho/m, $\epsilon_r = 39.2947$, $\rho = 1000$ kg/m³)

Phantom section: Right Section

DASY4 Configuration:

- Probe: ET3DV6 - SN1760; ConvF(5.13, 5.13, 5.13); Calibrated: 2004/2/17
- Sensor-Surface: 4mm (Mechanical And Optical Surface Detection)
- Electronics: DAE3 Sn547; Calibrated: 2004/2/10
- Phantom: SAM 12; Type: SAM 4.0; Serial: TP:1150
- Measurement SW: DASY4, V4.1 Build 47; Postprocessing SW: SEMCAD, V1.6 Build 115

GSM 1900 Right-Tilt/Area Scan (51x101x1): Measurement grid: dx=15mm, dy=15mm

Reference Value = 12.8 V/m

Power Drift = -0.006 dB

Maximum value of SAR = 0.318 mW/g

GSM 1900 Right-Tilt/Zoom Scan (7x7x7)/Cube 0: Measurement grid: dx=5mm, dy=5mm, dz=5mm

Peak SAR (extrapolated) = 0.537 W/kg

SAR(1 g) = 0.3 mW/g; SAR(10 g) = 0.155 mW/g

Reference Value = 12.8 V/m

Power Drift = -0.006 dB

Maximum value of SAR = 0.334 mW/g

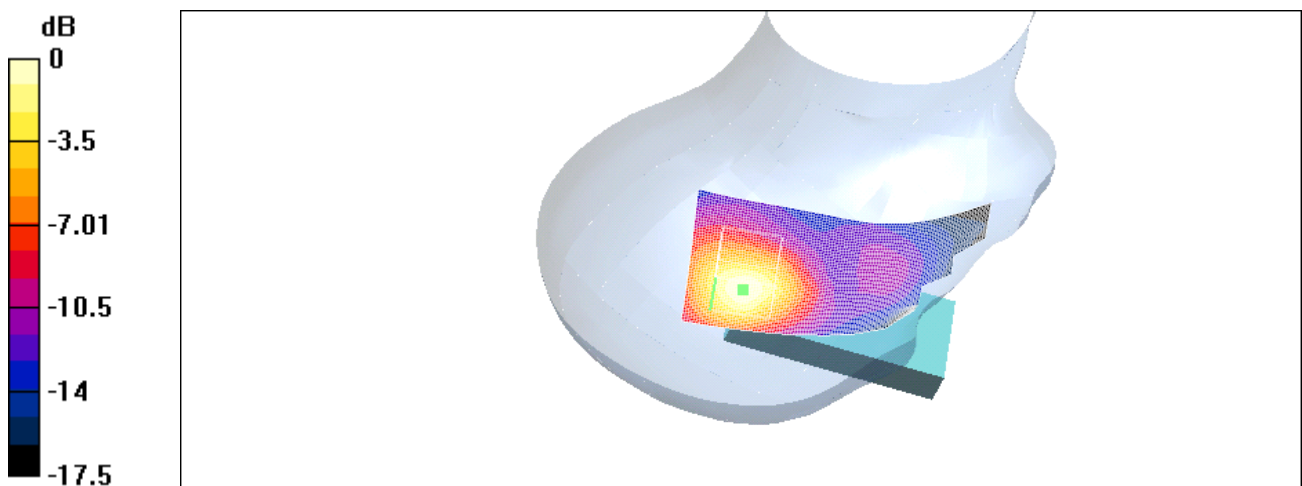

0 dB = 0.334mW/g

Right-Head Tilt CH810

DUT: TELIT G83; Type: Embedded; IMEI: 350166000084611

Program: GSM 1900MHZ

Communication System: GSM 1900; Frequency: 1909.8 MHz; Duty Cycle: 1:8.3

Medium: Head 1900MHz ($\sigma = 1.45412$ mho/m, $\epsilon_r = 39.4901$, $\rho = 1000$ kg/m³)

Phantom section: Right Section

DASY4 Configuration:

- Probe: ET3DV6 - SN1760; ConvF(5.1, 5.1, 5.1); Calibrated: 2004/2/17
- Sensor-Surface: 4mm (Mechanical And Optical Surface Detection)
- Electronics: DAE3 Sn547; Calibrated: 2004/2/10
- Phantom: SAM 12; Type: SAM 4.0; Serial: TP:1150
- Measurement SW: DASY4, V4.1 Build 47; Postprocessing SW: SEMCAD, V1.6 Build 115

GSM 1900 Right-Tilt/Area Scan (51x101x1): Measurement grid: dx=15mm, dy=15mm

Reference Value = 13 V/m

Power Drift = -0.02 dB

Maximum value of SAR = 0.323 mW/g

GSM 1900 Right-Tilt/Zoom Scan (7x7x7)/Cube 0: Measurement grid: dx=5mm, dy=5mm, dz=5mm

Peak SAR (extrapolated) = 0.553 W/kg

SAR(1 g) = 0.304 mW/g; SAR(10 g) = 0.159 mW/g

Reference Value = 13 V/m

Power Drift = -0.02 dB

Maximum value of SAR = 0.337 mW/g

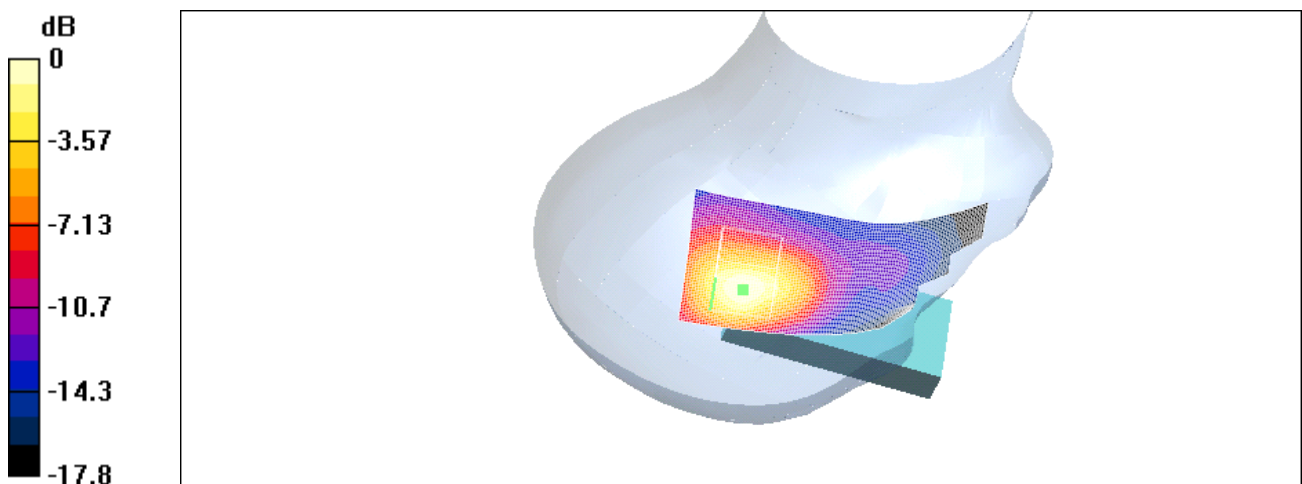

Left-Head Tilt CH512

DUT: TELIT G83; Type: Embedded; IMEI: 350166000084611

Program: GSM 1900MHZ

Communication System: GSM 1900; Frequency: 1850.2 MHz;Duty Cycle: 1:8.3

Medium: Head 1900MHZ ($\sigma = 1.3647$ mho/m, $\epsilon_r = 39.1801$, $\rho = 1000$ kg/m³)

Phantom section: Left Section

DASY4 Configuration:

- Probe: ET3DV6 - SN1760; ConvF(5.13, 5.13, 5.13); Calibrated: 2004/2/17
- Sensor-Surface: 4mm (Mechanical And Optical Surface Detection)
- Electronics: DAE3 Sn547; Calibrated: 2004/2/10
- Phantom: SAM 12; Type: SAM 4.0; Serial: TP:1150
- Measurement SW: DASY4, V4.1 Build 47; Postprocessing SW: SEMCAD, V1.6 Build 115

GSM 1900 Left-Tilt/Area Scan (51x101x1): Measurement grid: dx=15mm, dy=15mm

Reference Value = 14.1 V/m

Power Drift = -0.004 dB

Maximum value of SAR = 0.28 mW/g

GSM 1900 Left-Tilt/Zoom Scan (7x7x7)/Cube 0: Measurement grid: dx=5mm, dy=5mm, dz=5mm

Peak SAR (extrapolated) = 0.417 W/kg

SAR(1 g) = 0.252 mW/g; SAR(10 g) = 0.143 mW/g

Reference Value = 14.1 V/m

Power Drift = -0.004 dB

Maximum value of SAR = 0.273 mW/g

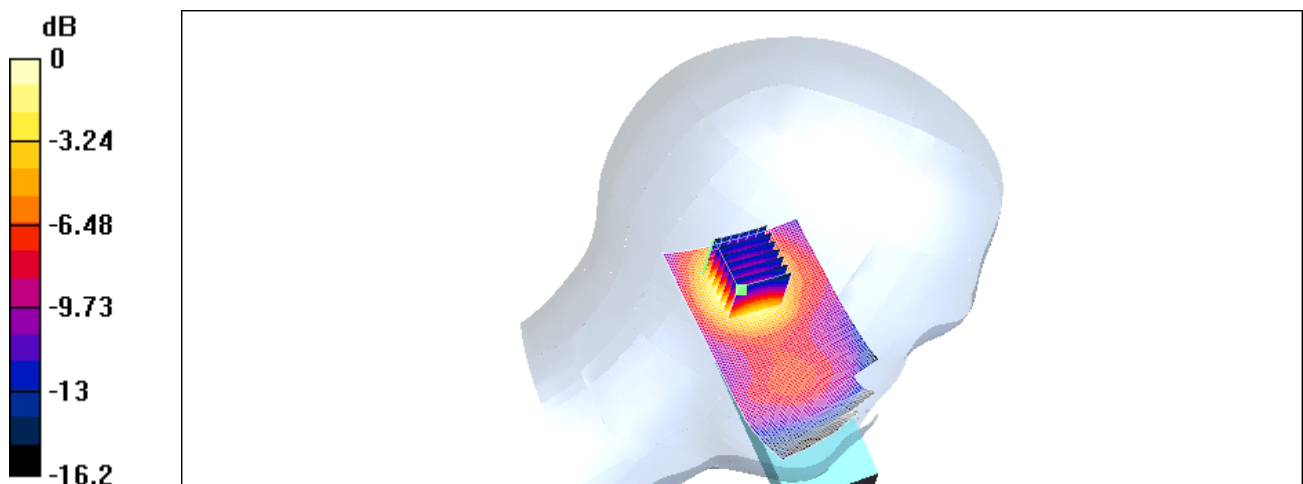

0 dB = 0.273mW/g

Left -Head Tilt CH661

DUT: TELIT G83; Type: Embedded; IMEI: 350166000084611

Program: GSM 1900MHZ

Communication System: GSM 1900; Frequency: 1880 MHz;Duty Cycle: 1:8.3

Medium: Head 1900MHZ ($\sigma = 1.42002$ mho/m, $\epsilon_r = 39.2947$, $\rho = 1000$ kg/m³)

Phantom section: Left Section

DASY4 Configuration:

- Probe: ET3DV6 - SN1760; ConvF(5.13, 5.13, 5.13); Calibrated: 2004/2/17
- Sensor-Surface: 4mm (Mechanical And Optical Surface Detection)
- Electronics: DAE3 Sn547; Calibrated: 2004/2/10
- Phantom: SAM 12; Type: SAM 4.0; Serial: TP:1150
- Measurement SW: DASY4, V4.1 Build 47; Postprocessing SW: SEMCAD, V1.6 Build 115

GSM 1900 Left-Tilt/Area Scan (51x101x1): Measurement grid: dx=15mm, dy=15mm

Reference Value = 14 V/m

Power Drift = -0.03 dB

Maximum value of SAR = 0.296 mW/g

GSM 1900 Left-Tilt/Zoom Scan (7x7x7)/Cube 0: Measurement grid: dx=5mm, dy=5mm, dz=5mm

Peak SAR (extrapolated) = 0.444 W/kg

SAR(1 g) = 0.267 mW/g; SAR(10 g) = 0.151 mW/g

Reference Value = 14 V/m

Power Drift = -0.03 dB

Maximum value of SAR = 0.287 mW/g

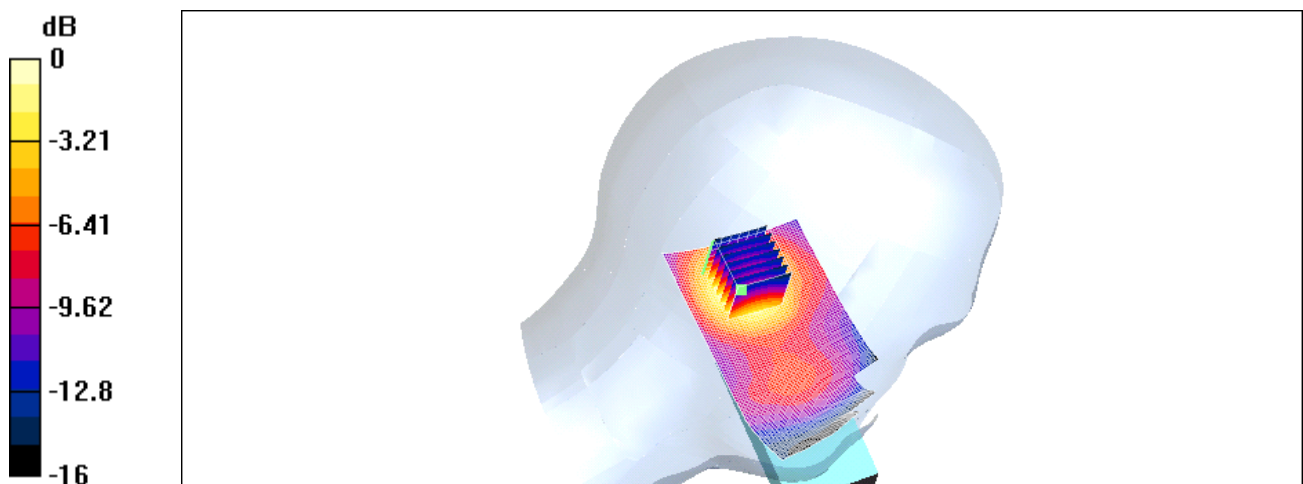

0 dB = 0.287mW/g

Left -Head Tilt CH810

DUT: TELIT G83; Type: Embedded; IMEI: 350166000084611

Program: GSM 1900MHZ

Communication System: GSM 1900; Frequency: 1909.8 MHz; Duty Cycle: 1:8.3

Medium: Head 1900MHz ($\sigma = 1.45412$ mho/m, $\epsilon_r = 39.4901$, $\rho = 1000$ kg/m³)

Phantom section: Left Section

DASY4 Configuration:

- Probe: ET3DV6 - SN1760; ConvF(5.1, 5.1, 5.1); Calibrated: 2004/2/17
- Sensor-Surface: 4mm (Mechanical And Optical Surface Detection)
- Electronics: DAE3 Sn547; Calibrated: 2004/2/10
- Phantom: SAM 12; Type: SAM 4.0; Serial: TP:1150
- Measurement SW: DASY4, V4.1 Build 47; Postprocessing SW: SEMCAD, V1.6 Build 115

GSM 1900 Left-Tilt/Area Scan (51x101x1): Measurement grid: dx=15mm, dy=15mm

Reference Value = 14.6 V/m

Power Drift = 0.05 dB

Maximum value of SAR = 0.318 mW/g

GSM 1900 Left-Tilt/Zoom Scan (7x7x7)/Cube 0: Measurement grid: dx=5mm, dy=5mm, dz=5mm

Peak SAR (extrapolated) = 0.483 W/kg

SAR(1 g) = 0.289 mW/g; SAR(10 g) = 0.165 mW/g

Reference Value = 14.6 V/m

Power Drift = 0.05 dB

Maximum value of SAR = 0.312 mW/g

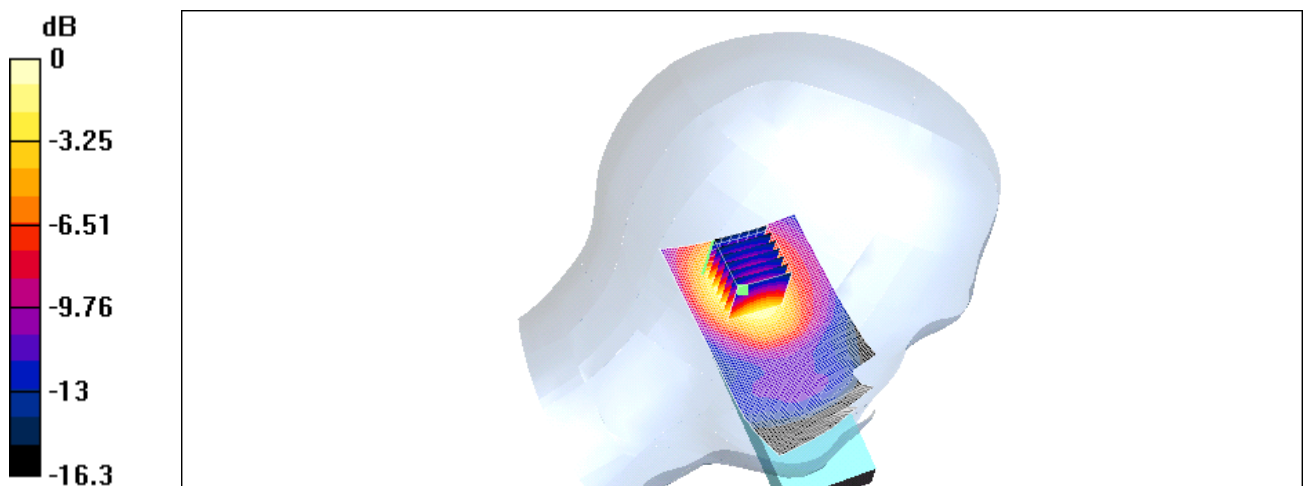

0 dB = 0.312mW/g

Body-Worn CH512

DUT: TELIT G83; Type: Embedded; IMEI: 350166000084611

Program: GSM 1900MHZ

Communication System: GSM 1900; Frequency: 1850.2 MHz; Duty Cycle: 1:4

Medium: M1800 & 1900 ($\sigma = 1.52427$ mho/m, $\epsilon_r = 53.3828$, $\rho = 1000$ kg/m³)

Phantom section: Flat Section

DASY4 Configuration:

- Probe: ET3DV6 - SN1760; ConvF(4.56, 4.56, 4.56); Calibrated: 2004/2/17
- Sensor-Surface: 4mm (Mechanical And Optical Surface Detection)
- Electronics: DAE3 Sn547; Calibrated: 2004/2/10
- Phantom: SAM 12; Type: SAM 4.0; Serial: TP:1150
- Measurement SW: DASY4, V4.1 Build 47; Postprocessing SW: SEMCAD, V1.6 Build 115

GSM 1900 Body/Area Scan (51x91x1): Measurement grid: dx=15mm, dy=15mm

Reference Value = 8.26 V/m

Power Drift = 0.02 dB

Maximum value of SAR = 0.251 mW/g

GSM 1900 Body/Zoom Scan (7x7x7)/Cube 0: Measurement grid: dx=5mm, dy=5mm, dz=5mm

Peak SAR (extrapolated) = 0.352 W/kg

SAR(1 g) = 0.233 mW/g; SAR(10 g) = 0.142 mW/g

Reference Value = 8.26 V/m

Power Drift = 0.02 dB

Maximum value of SAR = 0.251 mW/g

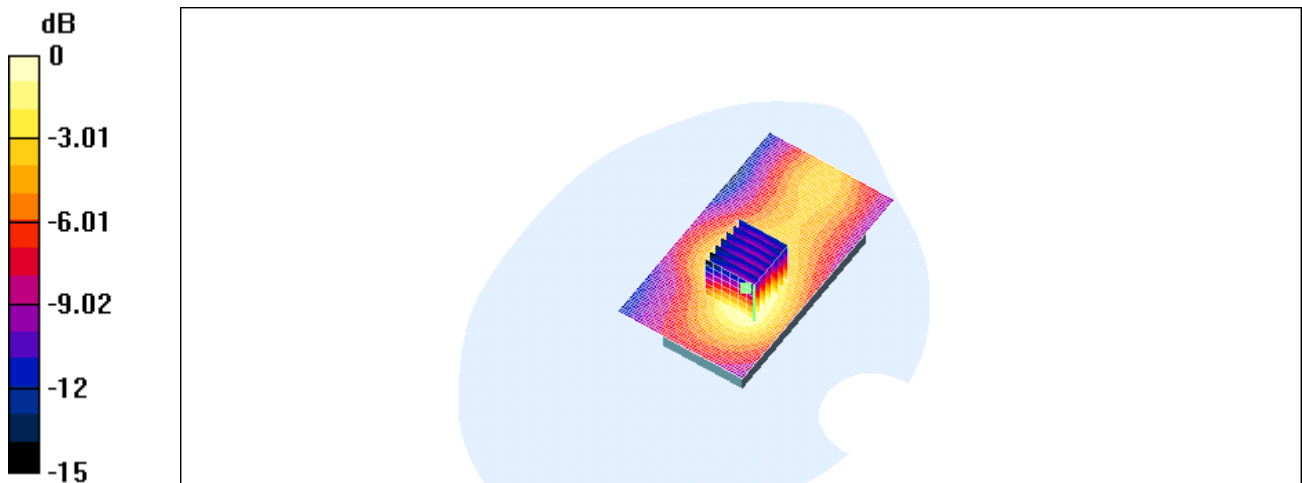

0 dB = 0.251mW/g

Body-Worn CH661

DUT: TELIT G83; Type: Embedded; IMEI: 350166000084611

Program: GSM 1900MHZ

Communication System: GSM 1900; Frequency: 1880 MHz; Duty Cycle: 1:4

Medium: M1800 & 1900 ($\sigma = 1.54797$ mho/m, $\epsilon_r = 53.127$, $\rho = 1000$ kg/m³)

Phantom section: Flat Section

DASY4 Configuration:

- Probe: ET3DV6 - SN1760; ConvF(4.56, 4.56, 4.56); Calibrated: 2004/2/17
- Sensor-Surface: 4mm (Mechanical And Optical Surface Detection)
- Electronics: DAE3 Sn547; Calibrated: 2004/2/10
- Phantom: SAM 12; Type: SAM 4.0; Serial: TP:1150
- Measurement SW: DASY4, V4.1 Build 47; Postprocessing SW: SEMCAD, V1.6 Build 115

GSM 1900 Body/Area Scan (51x91x1): Measurement grid: dx=15mm, dy=15mm

Reference Value = 8.15 V/m

Power Drift = 0.01 dB

Maximum value of SAR = 0.235 mW/g

GSM 1900 Body/Zoom Scan (7x7x7)/Cube 0: Measurement grid: dx=5mm, dy=5mm, dz=5mm

Peak SAR (extrapolated) = 0.346 W/kg

SAR(1 g) = 0.223 mW/g; SAR(10 g) = 0.136 mW/g

Reference Value = 8.15 V/m

Power Drift = 0.01 dB

Maximum value of SAR = 0.24 mW/g

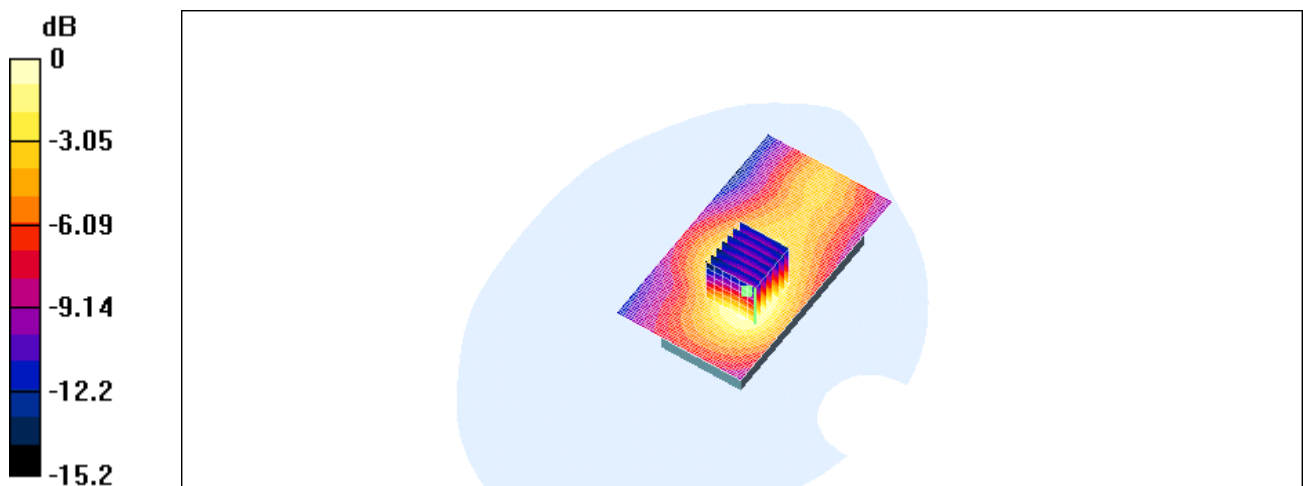

Body-Worn CH810

DUT: TELIT G83; Type: Embedded; IMEI: 350166000084611

Program: GSM 1900MHZ

Communication System: GSM 1900; Frequency: 1909.8 MHz; Duty Cycle: 1:4

Medium: M1800 & 1900 ($\sigma = 1.57022$ mho/m, $\epsilon_r = 53.1146$, $\rho = 1000$ kg/m³)

Phantom section: Flat Section

DASY4 Configuration:

- Probe: ET3DV6 - SN1760; ConvF(4.43, 4.43, 4.43); Calibrated: 2004/2/17
- Sensor-Surface: 4mm (Mechanical And Optical Surface Detection)
- Electronics: DAE3 Sn547; Calibrated: 2004/2/10
- Phantom: SAM 12; Type: SAM 4.0; Serial: TP:1150
- Measurement SW: DASY4, V4.1 Build 47; Postprocessing SW: SEMCAD, V1.6 Build 115

GSM 1900 Body/Area Scan (51x91x1): Measurement grid: dx=15mm, dy=15mm

Reference Value = 7.89 V/m

Power Drift = 0.03 dB

Maximum value of SAR = 0.209 mW/g

GSM 1900 Body/Zoom Scan (7x7x7)/Cube 0: Measurement grid: dx=5mm, dy=5mm, dz=5mm

Peak SAR (extrapolated) = 0.309 W/kg

SAR(1 g) = 0.196 mW/g; SAR(10 g) = 0.12 mW/g

Reference Value = 7.89 V/m

Power Drift = 0.03 dB

Maximum value of SAR = 0.212 mW/g

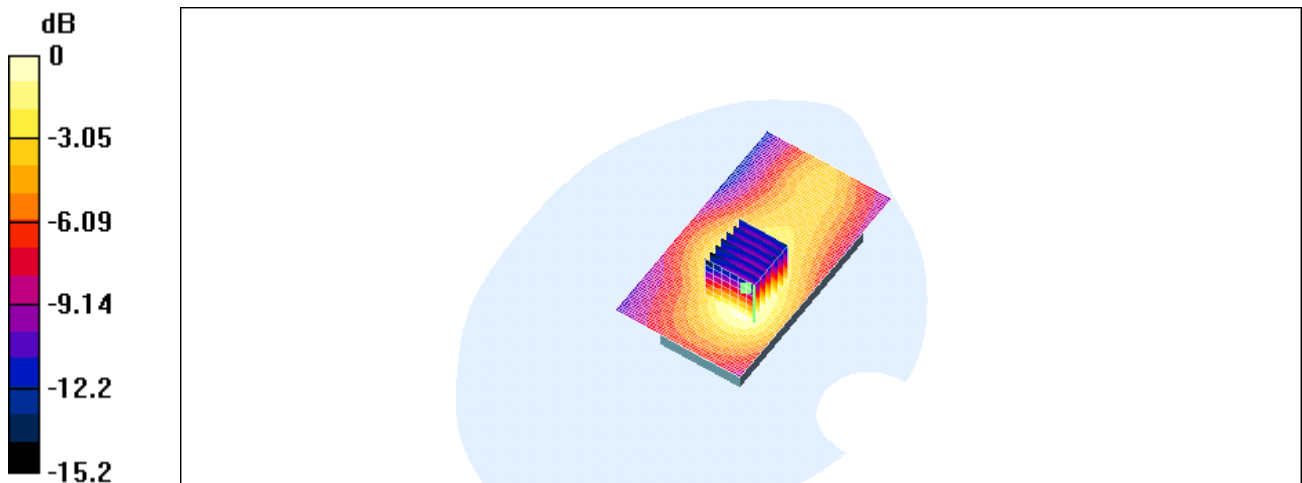

0 dB = 0.212mW/g

SAR System Performance Verification

Date/Time: 09/21/04 08:40:12

DUT: Dipole 1900 MHz; Type: D1900V2; Serial: D1900V2 - SN:5d027

Program: 20040921

Communication System: CW; Frequency: 1900 MHz; Duty Cycle: 1:1

Medium: Head 1900MHz ($\sigma = 1.4395$ mho/m, $\epsilon_r = 39.5797$, $\rho = 1000$ kg/m³)

Phantom section: Flat Section

DASY4 Configuration:

- Probe: ET3DV6 - SN1760; ConvF(5.1, 5.1, 5.1); Calibrated: 2004/2/17
- Sensor-Surface: 4mm (Mechanical And Optical Surface Detection)
- Electronics: DAE3 Sn547; Calibrated: 2004/2/10
- Phantom: SAM 12; Type: SAM 4.0; Serial: TP:1150
- Measurement SW: DASY4, V4.1 Build 47; Postprocessing SW: SEMCAD, V1.6 Build 115

Pin=250mw/Area Scan (101x101x1): Measurement grid: dx=10mm, dy=10mm

Reference Value = 92.7 V/m

Power Drift = 0.01 dB

Maximum value of SAR = 11.4 mW/g

Pin=250mw/Zoom Scan (7x7x7)/Cube 0: Measurement grid: dx=5mm, dy=5mm, dz=5mm

Peak SAR (extrapolated) = 18.3 W/kg

SAR(1 g) = 10 mW/g; SAR(10 g) = 5.21 mW/g

Reference Value = 92.7 V/m

Power Drift = 0.01 dB

Maximum value of SAR = 11.5 mW/g

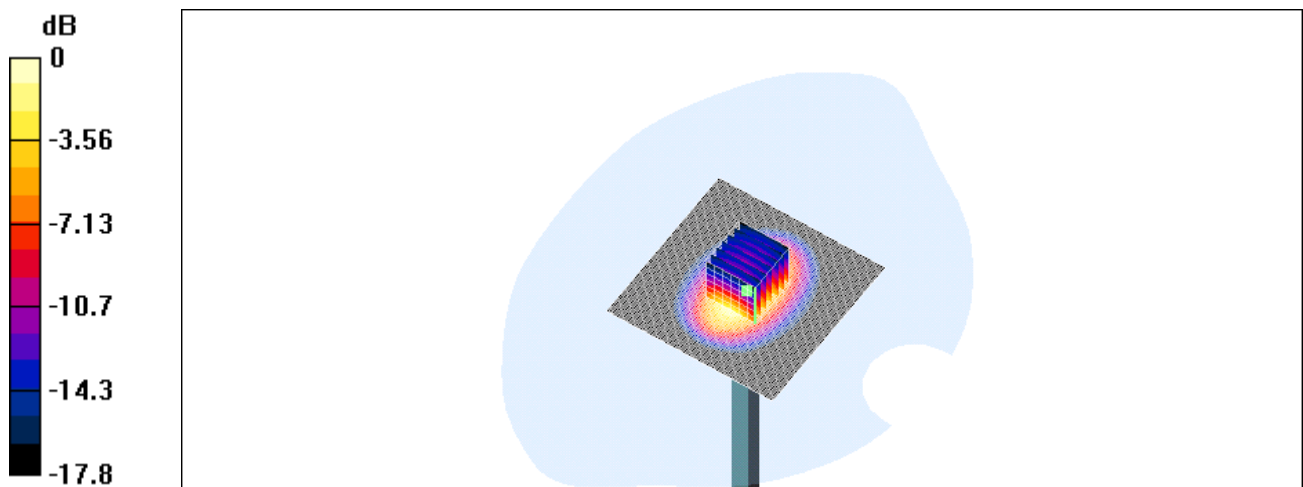

0 dB = 11.5mW/g

SAR System Performance Verification

Date/Time: 10/08/04 15:01:12

DUT: Dipole 1900 MHz; Type: D1900V2; Serial: D1900V2 - SN:5d027

Program: 20041008

Communication System: CW; Frequency: 1900 MHz; Duty Cycle: 1:1

Medium: Head 1900MHz Medium parameters used (interpolated): $f = 1900$ MHz; $\sigma = 1.44$ mho/m; $\epsilon_r = 39.68$; $\rho = 1000$ kg/m³

Phantom section: Flat Section

DASY4 Configuration:

- Probe: ET3DV6 - SN1760; ConvF(5.1, 5.1, 5.1); Calibrated: 2004/2/17
- Sensor-Surface: 4mm (Mechanical And Optical Surface Detection)
- Electronics: DAE3 Sn547; Calibrated: 2004/2/10
- Phantom: SAM 12; Type: SAM 4.0; Serial: TP:1150
- Measurement SW: DASY4, V4.3 Build 22; Postprocessing SW: SEMCAD, V1.8 Build 127

Pin=250mw/Area Scan (101x101x1): Measurement grid: dx=10mm, dy=10mm

Maximum value of SAR (interpolated) = 11.4 mW/g

Pin=250mw/Zoom Scan (7x7x7)/Cube 0: Measurement grid: dx=5mm, dy=5mm, dz=5mm

Reference Value = 93.6 V/m; Power Drift = 0.0 dB

Peak SAR (extrapolated) = 18 W/kg

SAR(1 g) = 10 mW/g; SAR(10 g) = 5.2 mW/g

Maximum value of SAR (measured) = 11.3 mW/g

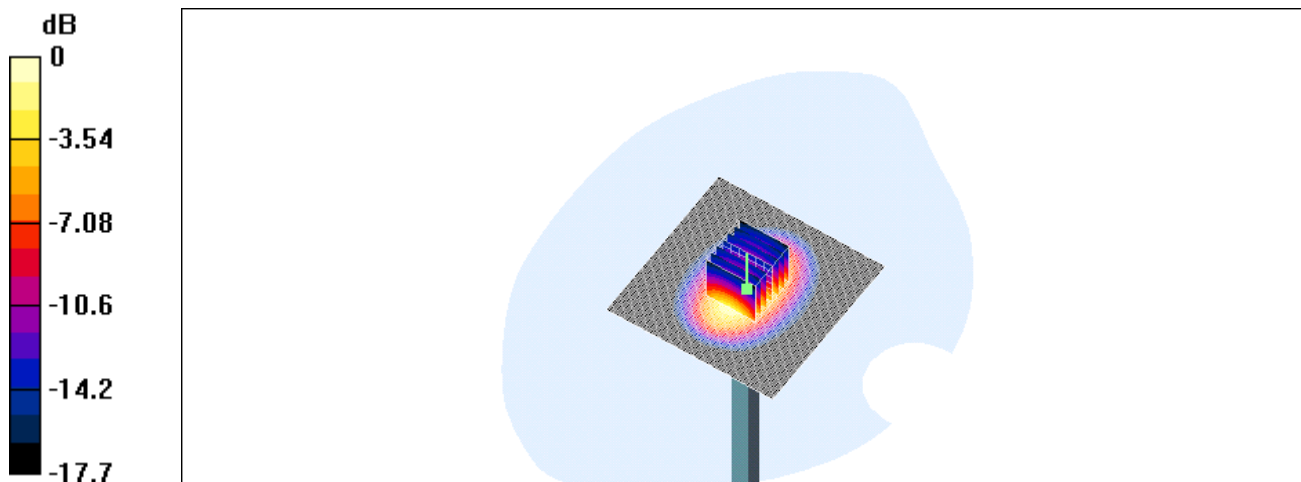

0 dB = 11.3mW/g

SAR System Performance Verification

Date/Time: 09/22/04 14:55:12

DUT: Dipole 1900 MHz; Type: D1900V2; Serial: D1900V2 - SN:5d027

Program: 20040922

Communication System: CW; Frequency: 1900 MHz; Duty Cycle: 1:1

Medium: M1800 & 1900 ($\sigma = 1.55653$ mho/m, $\epsilon_r = 53.1851$, $\rho = 1000$ kg/m³)

Phantom section: Flat Section

DASY4 Configuration:

- Probe: ET3DV6 - SN1760; ConvF(4.43, 4.43, 4.43); Calibrated: 2004/2/17
- Sensor-Surface: 4mm (Mechanical And Optical Surface Detection)
- Electronics: DAE3 Sn547; Calibrated: 2004/2/10
- Phantom: SAM 12; Type: SAM 4.0; IMEI: TP:1150
- Measurement SW: DASY4, V4.1 Build 47; Postprocessing SW: SEMCAD, V1.6 Build 115

Pin=250mw/Area Scan (101x101x1): Measurement grid: dx=10mm, dy=10mm

Reference Value = 92.9 V/m

Power Drift = -0.0007 dB

Maximum value of SAR = 11.7 mW/g

Pin=250mw/Zoom Scan (7x7x7)/Cube 0: Measurement grid: dx=5mm, dy=5mm, dz=5mm

Peak SAR (extrapolated) = 17.8 W/kg

SAR(1 g) = 10.2 mW/g; SAR(10 g) = 5.31 mW/g

Reference Value = 92.9 V/m

Power Drift = -0.0007 dB

Maximum value of SAR = 11.6 mW/g

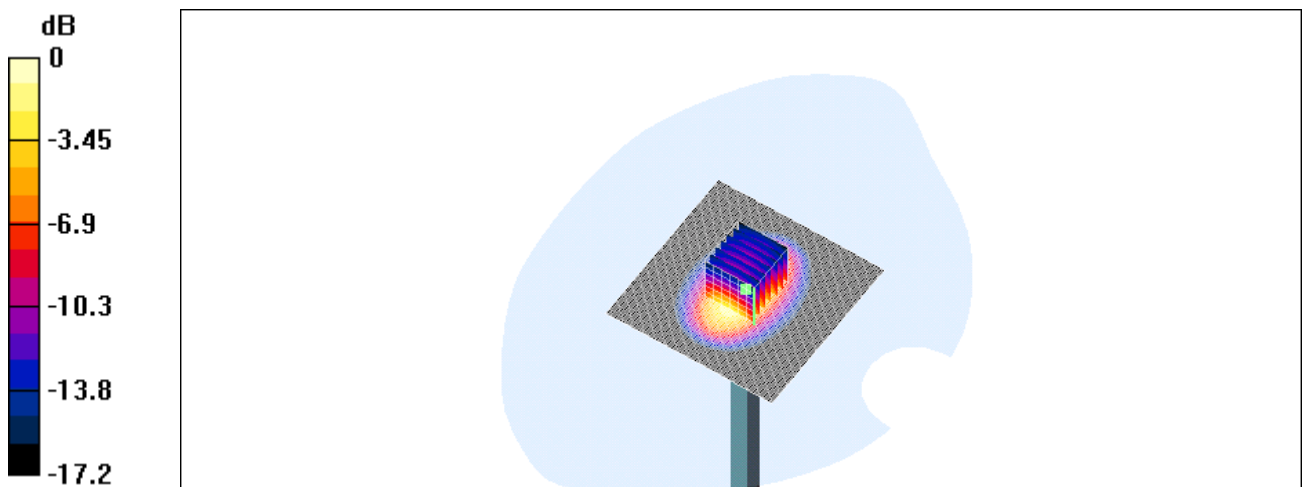

0 dB = 11.6mW/g

Appendix
Photographs of Test Setup



Fig.1 Photograph of the SAR measurement System

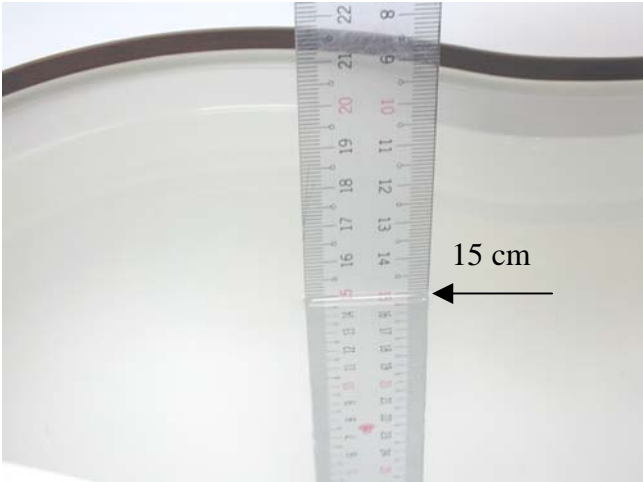

Fig.2 Photograph of the Tissue Simulant Fluid liquid depth 15cm for Right-head Side

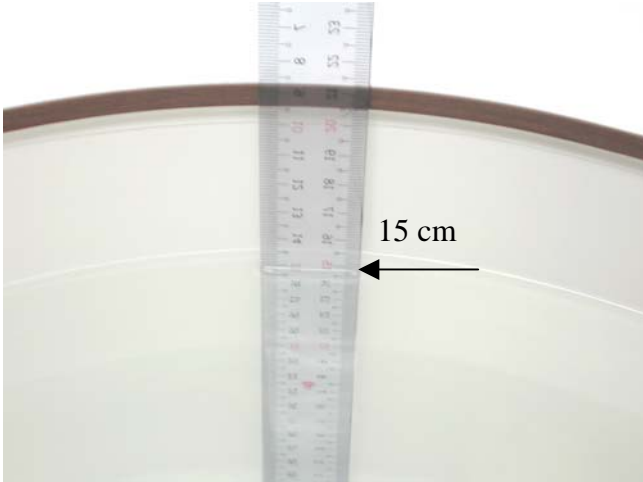

Fig.3 Photograph of the Tissue Simulant Fluid liquid depth 15cm for Flat (Body)

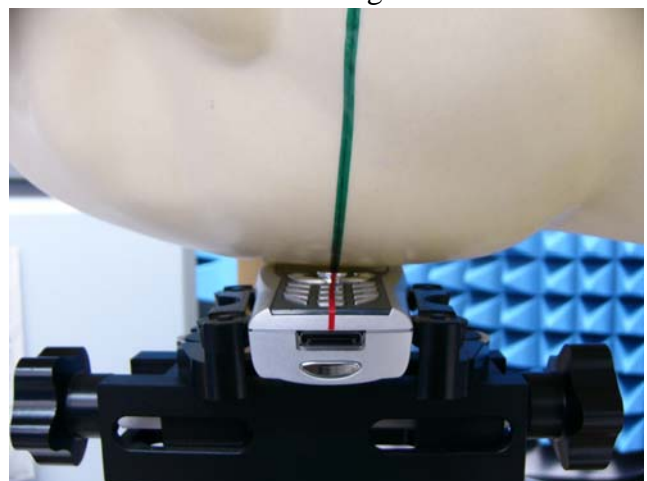
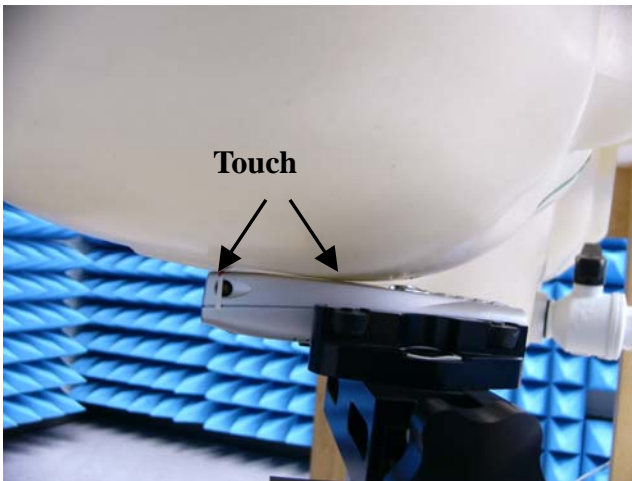

Fig.4 Right Head Section / Cheek-Touch Position

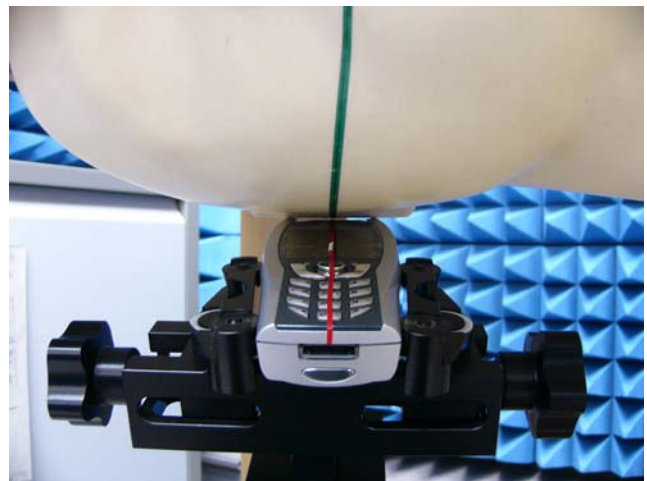
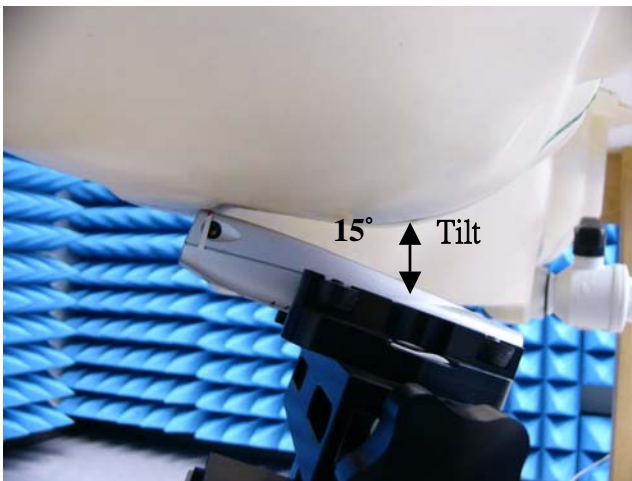

Fig.5 Right Head Section / Ear-Tilt Position(15°)

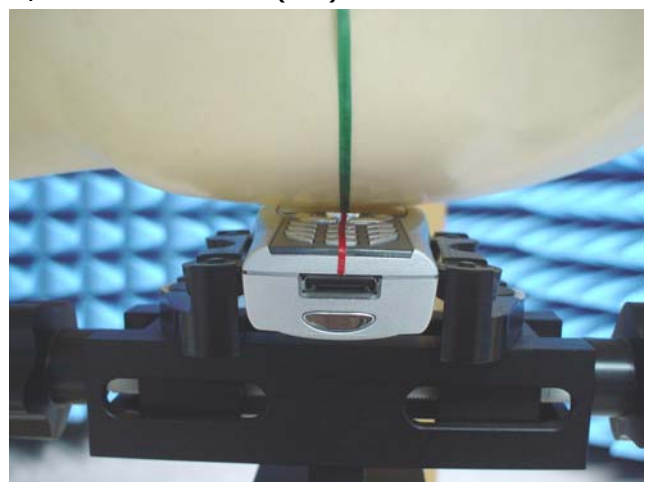
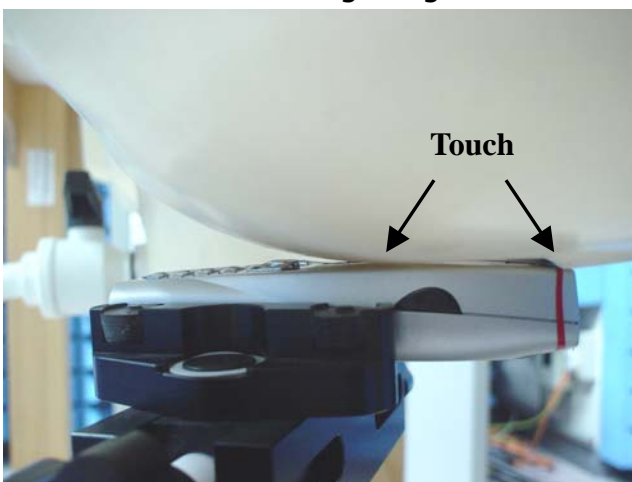

Fig.6 Left Head Section / Cheek-Touch Position

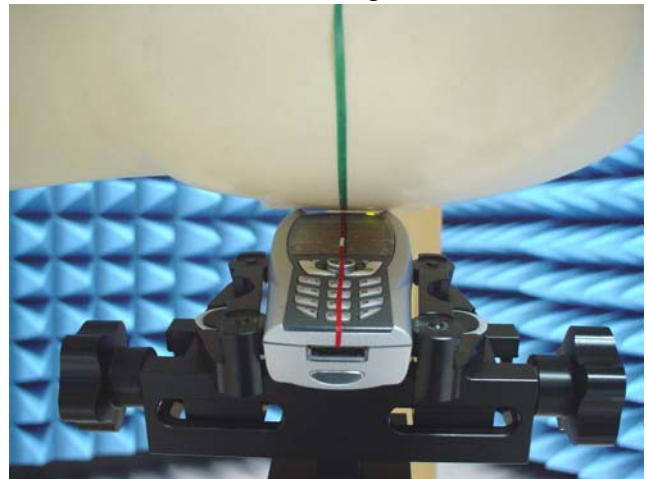
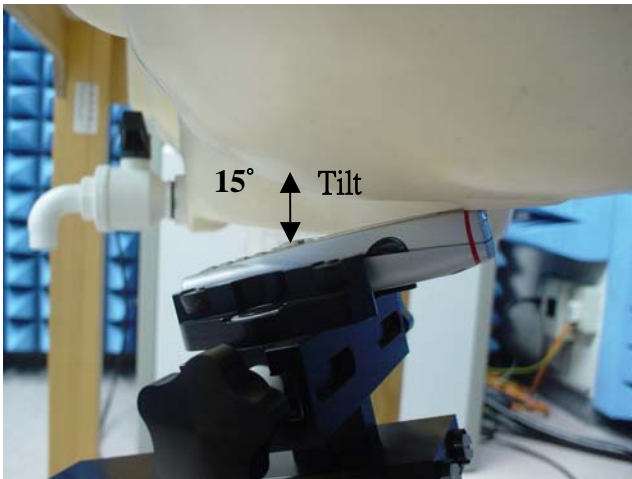

Fig.7 Left Head Section / Ear-Tilt Position(15°)

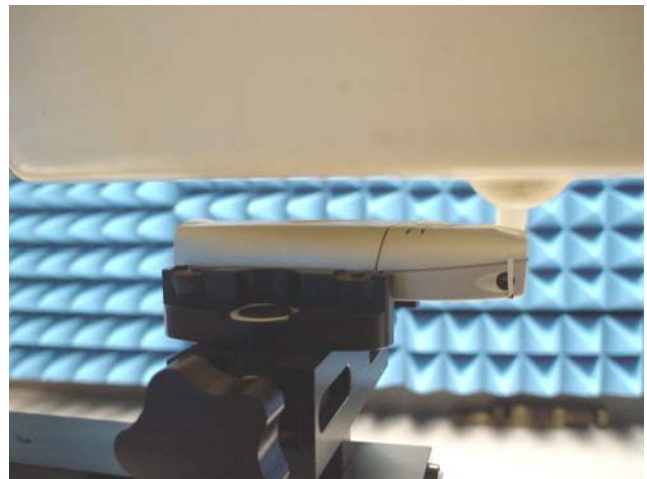
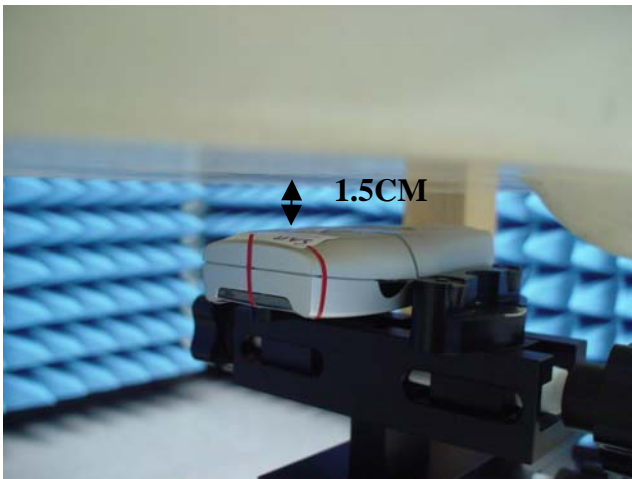

Fig.8 Body Worn with Headset Position

Photographs of the EUT



Fig.9 Front view of device



Fig.10 Back view of device



Fig.11 Front view of the Phone connect with Charger

Photographs of the Battery



Fig.12 Front view of Battery

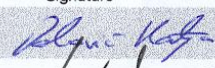
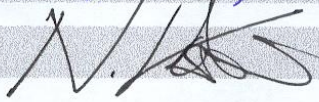

Fig.13 Black view of Battery

Probe Calibration certificate

**Calibration Laboratory of
Schmid & Partner
Engineering AG**
Zeughausstrasse 43, 8004 Zurich, Switzerland

Client **SGS Taiwan (Auden)**

CALIBRATION CERTIFICATE																																			
Object(s)	ET3DV6 - SN:1760																																		
Calibration procedure(s)	QA CAL-01.v2 Calibration procedure for dosimetric E-field probes																																		
Calibration date:	February 17, 2004																																		
Condition of the calibrated item	In Tolerance (according to the specific calibration document)																																		
<p>This calibration certificate documents the traceability to national standards, which realize the physical units of measurements (SI). The measurements and the uncertainties with confidence probability are given on the following pages and are part of the certificate.</p> <p>All calibrations have been conducted in the closed laboratory facility: environment temperature 22 +/- 2 degrees Celsius and humidity < 75%.</p> <p>Calibration Equipment used (M&TE critical for calibration)</p> <table border="1"> <thead> <tr> <th>Model Type</th> <th>ID #</th> <th>Cal Date (Calibrated by, Certificate No.)</th> <th>Scheduled Calibration</th> </tr> </thead> <tbody> <tr> <td>Power meter EPM E4419B</td> <td>GB41293874</td> <td>2-Apr-03 (METAS, No 252-0250)</td> <td>Apr-04</td> </tr> <tr> <td>Power sensor E4412A</td> <td>MY41495277</td> <td>2-Apr-03 (METAS, No 252-0250)</td> <td>Apr-04</td> </tr> <tr> <td>Reference 20 dB Attenuator</td> <td>SN: 5086 (20b)</td> <td>3-Apr-03 (METAS, No. 251-0340)</td> <td>Apr-04</td> </tr> <tr> <td>Fluke Process Calibrator Type 702</td> <td>SN: 6295803</td> <td>8-Sep-03 (Sintrel SCS No. E-030020)</td> <td>Sep-04</td> </tr> <tr> <td>Power sensor HP 8481A</td> <td>MY41092180</td> <td>18-Sep-02 (SPEAG, in house check Oct-03)</td> <td>In house check: Oct 05</td> </tr> <tr> <td>RF generator HP 8684C</td> <td>US3642U01700</td> <td>4-Aug-99 (SPEAG, in house check Aug-02)</td> <td>In house check: Aug-05</td> </tr> <tr> <td>Network Analyzer HP 8753E</td> <td>US37390585</td> <td>18-Oct-01 (SPEAG, in house check Oct-03)</td> <td>In house check: Oct 05</td> </tr> </tbody> </table>				Model Type	ID #	Cal Date (Calibrated by, Certificate No.)	Scheduled Calibration	Power meter EPM E4419B	GB41293874	2-Apr-03 (METAS, No 252-0250)	Apr-04	Power sensor E4412A	MY41495277	2-Apr-03 (METAS, No 252-0250)	Apr-04	Reference 20 dB Attenuator	SN: 5086 (20b)	3-Apr-03 (METAS, No. 251-0340)	Apr-04	Fluke Process Calibrator Type 702	SN: 6295803	8-Sep-03 (Sintrel SCS No. E-030020)	Sep-04	Power sensor HP 8481A	MY41092180	18-Sep-02 (SPEAG, in house check Oct-03)	In house check: Oct 05	RF generator HP 8684C	US3642U01700	4-Aug-99 (SPEAG, in house check Aug-02)	In house check: Aug-05	Network Analyzer HP 8753E	US37390585	18-Oct-01 (SPEAG, in house check Oct-03)	In house check: Oct 05
Model Type	ID #	Cal Date (Calibrated by, Certificate No.)	Scheduled Calibration																																
Power meter EPM E4419B	GB41293874	2-Apr-03 (METAS, No 252-0250)	Apr-04																																
Power sensor E4412A	MY41495277	2-Apr-03 (METAS, No 252-0250)	Apr-04																																
Reference 20 dB Attenuator	SN: 5086 (20b)	3-Apr-03 (METAS, No. 251-0340)	Apr-04																																
Fluke Process Calibrator Type 702	SN: 6295803	8-Sep-03 (Sintrel SCS No. E-030020)	Sep-04																																
Power sensor HP 8481A	MY41092180	18-Sep-02 (SPEAG, in house check Oct-03)	In house check: Oct 05																																
RF generator HP 8684C	US3642U01700	4-Aug-99 (SPEAG, in house check Aug-02)	In house check: Aug-05																																
Network Analyzer HP 8753E	US37390585	18-Oct-01 (SPEAG, in house check Oct-03)	In house check: Oct 05																																
Calibrated by:	Name Katja Pokovic	Function Laboratory Director	Signature 																																
Approved by:	Name Niels Kuster	Function Quality Manager	Signature 																																
Date issued: February 17, 2004																																			
<p>This calibration certificate is issued as an intermediate solution until the accreditation process (based on ISO/IEC 17025 International Standard) for Calibration Laboratory of Schmid & Partner Engineering AG is completed.</p>																																			

Probe ET3DV6

SN:1760

Manufactured:	November 12, 2002
Last calibrated:	March 7, 2003
Recalibrated:	February 17, 2004

Calibrated for DASY Systems

(Note: non-compatible with DASY2 system!)

ET3DV6 SN:1760

February 17, 2004

Receiving Pattern (ϕ), $\theta = 0^\circ$

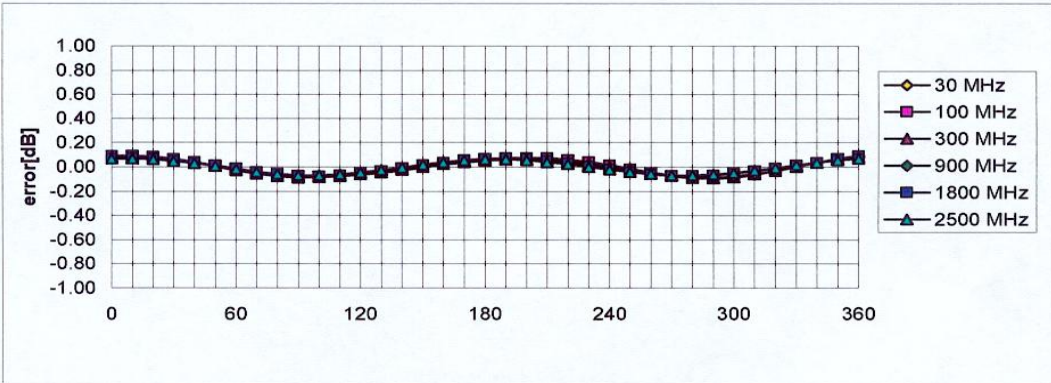
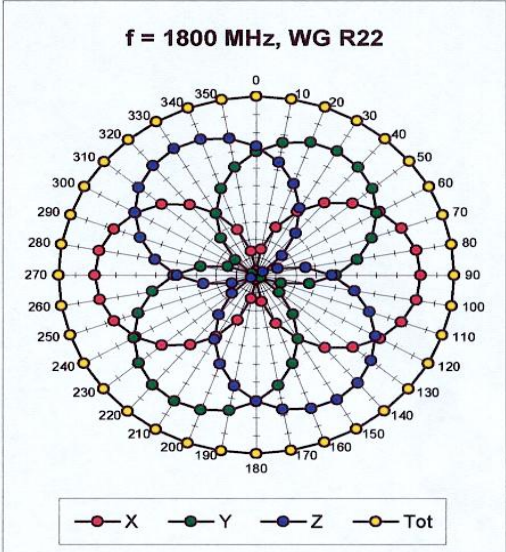
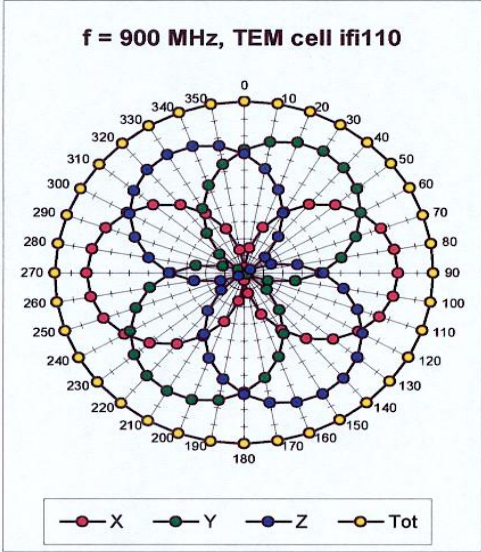

Axial Isotropy Error $\pm 0.2\text{ dB}$

ET3DV6 SN:1760

February 17, 2004

Conversion Factor Assessment

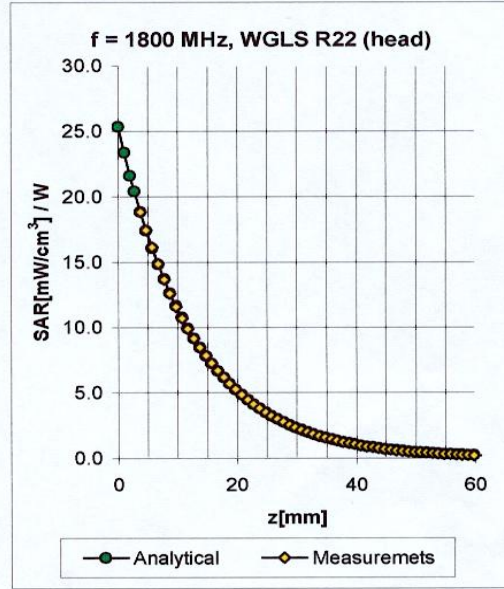
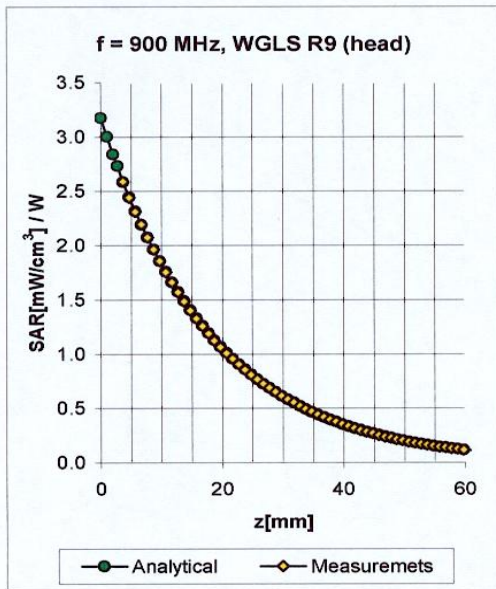

f [MHz]	Validity [MHz] ^B	Tissue	Permittivity	Conductivity	Alpha	Depth	ConvF Uncertainty
900	800-1000	Head	41.5 ± 5%	0.97 ± 5%	0.51	1.96	6.34 ± 11.3% (k=2)
1800	1710-1890	Head	40.0 ± 5%	1.40 ± 5%	0.52	2.36	5.13 ± 10.9% (k=2)
1900	1805-1995	Head	40.0 ± 5%	1.40 ± 5%	0.54	2.42	5.10 ± 11.1% (k=2)
900	800-1000	Body	55.0 ± 5%	1.05 ± 5%	0.43	2.21	6.04 ± 11.3% (k=2)
1800	1710-1890	Body	53.3 ± 5%	1.52 ± 5%	0.60	2.56	4.56 ± 10.9% (k=2)
1900	1805-1995	Body	53.3 ± 5%	1.52 ± 5%	0.59	2.76	4.43 ± 11.1% (k=2)
2450	2400-2500	Body	52.7 ± 5%	1.95 ± 5%	1.47	1.45	4.18 ± 9.7% (k=2)

^B The total standard uncertainty is calculated as root-sum-square of standard uncertainty of the Conversion Factor at calibration frequency and the standard uncertainty for the indicated frequency band.

Uncertainty Analysis

DASY4 Uncertainty Budget According to IEEE P1528 [1]								
Error Description	Uncertainty value	Prob. Dist.	Div.	(c_i) 1g	(c_i) 10g	Std. Unc. (1g)	Std. Unc. (10g)	(v_i) v_{eff}
Measurement System								
Probe Calibration	±4.8 %	N	1	1	1	±4.8 %	±4.8 %	∞
Axial Isotropy	±4.7 %	R	$\sqrt{3}$	0.7	0.7	±1.9 %	±1.9 %	∞
Hemispherical Isotropy	±9.6 %	R	$\sqrt{3}$	0.7	0.7	±3.9 %	±3.9 %	∞
Boundary Effects	±1.0 %	R	$\sqrt{3}$	1	1	±0.6 %	±0.6 %	∞
Linearity	±4.7 %	R	$\sqrt{3}$	1	1	±2.7 %	±2.7 %	∞
System Detection Limits	±1.0 %	R	$\sqrt{3}$	1	1	±0.6 %	±0.6 %	∞
Readout Electronics	±1.0 %	N	1	1	1	±1.0 %	±1.0 %	∞
Response Time	±0.8 %	R	$\sqrt{3}$	1	1	±0.5 %	±0.5 %	∞
Integration Time	±2.6 %	R	$\sqrt{3}$	1	1	±1.5 %	±1.5 %	∞
RF Ambient Conditions	±3.0 %	R	$\sqrt{3}$	1	1	±1.7 %	±1.7 %	∞
Probe Positioner	±0.4 %	R	$\sqrt{3}$	1	1	±0.2 %	±0.2 %	∞
Probe Positioning	±2.9 %	R	$\sqrt{3}$	1	1	±1.7 %	±1.7 %	∞
Max. SAR Eval.	±1.0 %	R	$\sqrt{3}$	1	1	±0.6 %	±0.6 %	∞
Test Sample Related								
Device Positioning	±2.9 %	N	1	1	1	±2.9 %	±2.9 %	875
Device Holder	±3.6 %	N	1	1	1	±3.6 %	±3.6 %	5
Power Drift	±5.0 %	R	$\sqrt{3}$	1	1	±2.9 %	±2.9 %	∞
Phantom and Setup								
Phantom Uncertainty	±4.0 %	R	$\sqrt{3}$	1	1	±2.3 %	±2.3 %	∞
Liquid Conductivity (target)	±5.0 %	R	$\sqrt{3}$	0.64	0.43	±1.8 %	±1.2 %	∞
Liquid Conductivity (meas.)	±2.5 %	N	1	0.64	0.43	±1.6 %	±1.1 %	∞
Liquid Permittivity (target)	±5.0 %	R	$\sqrt{3}$	0.6	0.49	±1.7 %	±1.4 %	∞
Liquid Permittivity (meas.)	±2.5 %	N	1	0.6	0.49	±1.5 %	±1.2 %	∞
Combined Std. Uncertainty						±10.3 %	±10.0 %	331
Expanded STD Uncertainty						±20.6 %	±20.1 %	

Phantom description

**Schmid & Partner
Engineering AG**

Zeughausstrasse 43, 8004 Zurich, Switzerland, Phone +41 1 245 97 00, Fax +41 1 245 97 79

Certificate of conformity / First Article Inspection

Item	SAM Twin Phantom V4.0
Type No	QD 000 P40 CA
Series No	TP-1150 and higher
Manufacturer / Origin	Unterse Composite Hauptstr. 69 CH-8559 Fruthwilen Switzerland

Tests

The series production process used allows the limitation to test of first articles. Complete tests were made on the pre-series Type No. QD 000 P40 AA, Serial No. TP-1001 and on the series first article Type No. QD 000 P40 BA, Serial No. TP-1006. Certain parameters have been retested using further series units (called samples).

Test	Requirement	Details	Units tested
Shape	Compliance with the geometry according to the CAD model.	IT'S CAD File (*)	First article, Samples
Material thickness	Compliant with the requirements according to the standards	2mm +/- 0.2mm in specific areas	First article, Samples
Material parameters	Dielectric parameters for required frequencies	200 MHz - 3 GHz Relative permittivity < 5 Loss tangent < 0.05.	Material sample TP 104-5
Material resistivity	The material has been tested to be compatible with the liquids defined in the standards	Liquid type HSL 1800 and others according to the standard.	Pre-series, First article

Standards

- [1] CENELEC EN 50361
- [2] IEEE P1528-200x draft 6.5
- [3] IEC PT 62209 draft 0.9

(*) The IT'S CAD file is derived from [2] and is also within the tolerance requirements of the shapes of [1] and [3].

Conformity

Based on the sample tests above, we certify that this item is in compliance with the uncertainty requirements of SAR measurements specified in standard [1] and draft standards [2] and [3].

Date

28.02.2002

Signature / Stamp

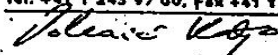
**Schmid & Partner
Engineering AG**Zeughausstrasse 43, CH-8004 Zurich
Tel. +41 1 245 97 00, Fax +41 1 245 97 79

System Validation from Original equipment supplier SPEAG Schmid & Partner of GSM 1900 HSL & Muscle

Page 1 of 1

Date/Time: 02/17/04 13:19:33

Test Laboratory: SPEAG, Zurich, Switzerland

DUT: Dipole 1900 MHz; Type: D1900V2; Serial: D1900V2 - SN5d027

Communication System: CW-1900; Frequency: 1900 MHz; Duty Cycle: 1:1

Medium: HSL 1900 MHz;

Medium parameters used: $f = 1900$ MHz; $\sigma = 1.47$ mho/m; $\epsilon_r = 38.8$; $\rho = 1000$ kg/m³

Phantom section: Flat Section

Measurement Standard: DASy4 (High Precision Assessment)

DASy4 Configuration:

- Probe: ET3DV6 - SN1507; ConvF(4.96, 4.96, 4.96); Calibrated: 1/23/2004
- Sensor-Surface: 4mm (Mechanical Surface Detection)
- Electronics: DAE3 Sn411; Calibrated: 1/16/2003
- Phantom: SAM with CRP - TP1006; Type: SAM 4.0; Serial: TP:1006;
- Measurement SW: DASy4, V4.2 Build 30; Postprocessing SW: SEMCAD, V1.8 Build 101

Pin = 250 mW; d = 10 mm/Area Scan (81x81x1): Measurement grid: dx=15mm, dy=15mm

Reference Value = 93 V/m; Power Drift = 0.0 dB

Maximum value of SAR (interpolated) = 11.9 mW/g

Pin = 250 mW; d = 10 mm/Zoom Scan (7x7x7)/Cube 0: Measurement grid: dx=5mm, dy=5mm, dz=5mm

Reference Value = 93 V/m; Power Drift = 0.0 dB

Maximum value of SAR (measured) = 11.9 mW/g

Peak SAR (extrapolated) = 18.8 W/kg

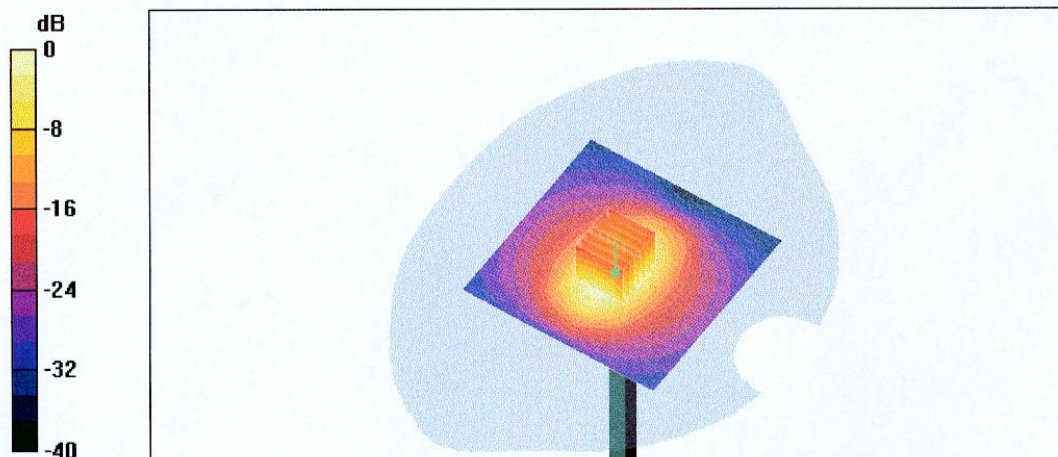
SAR(1 g) = 10.5 mW/g; SAR(10 g) = 5.44 mW/g

0 dB = 11.9mW/g

Test Laboratory: SPEAG, Zurich, Switzerland

DUT: Dipole 1900 MHz; Type: D1900V2; Serial: D1900V2 - SN5d027

Communication System: CW-1900; Frequency: 1900 MHz; Duty Cycle: 1:1

Medium: Muscle 1900 MHz

Medium parameters used: $f = 1900 \text{ MHz}$; $\sigma = 1.58 \text{ mho/m}$; $\epsilon_r = 52.5$; $\rho = 1000 \text{ kg/m}^3$

Phantom section: Flat Section

Measurement Standard: DASy4 (High Precision Assessment)

DASy4 Configuration:

- Probe: ET3DV6 - SN1507; ConvF(4.57, 4.57, 4.57); Calibrated: 1/23/2004
- Sensor-Surface: 4mm (Mechanical Surface Detection)
- Electronics: DAE3 - SN411; Calibrated: 1/16/2003
- Phantom: SAM with CRP - TP1006; Type: SAM 4.0; Serial: TP:1006
- Measurement SW: DASy4, V4.2 Build 25; Postprocessing SW: SEMCAD, V2.0 Build 19

Pin = 250 mW; d = 10 mm/Area Scan (81x81x1): Measurement grid: $dx=15\text{mm}$, $dy=15\text{mm}$

Reference Value = 92.5 V/m

Power Drift = 0.002 dB

Maximum value of SAR = 12.1 mW/g

Pin = 250 mW; d = 10 mm/Zoom Scan (7x7x7)/Cube 0: Measurement grid: $dx=5\text{mm}$, $dy=5\text{mm}$, $dz=5\text{mm}$

Peak SAR (extrapolated) = 19.3 W/kg

SAR(1 g) = 10.7 mW/g; SAR(10 g) = 5.6 mW/g

Reference Value = 92.5 V/m

Power Drift = 0.002 dB

Maximum value of SAR = 12.1 mW/g

