



A D T

FCC TEST REPORT

REPORT NO.: RF150727C14

MODEL NO.: 601

FCC ID: RGQ-601

RECEIVED: Jul. 27, 2015

TESTED: Aug. 01, 2015 ~ Aug. 05, 2015

ISSUED: Aug. 11, 2015

APPLICANT: Pebble Technology Corporation

ADDRESS: 639 High St., Palo Alto, CA 94301, United States

ISSUED BY: Bureau Veritas Consumer Products Services (H.K.)
Ltd., Taoyuan Branch

LAB ADDRESS: No. 47-2, 14th Ling, Chia Pau Vil., Lin Kou Dist.,
New Taipei City, Taiwan (R.O.C)

TEST LOCATION: No.19, Hwa Ya 2nd Rd., Wen Hwa Vil., Kwei Shan
Dist., Taoyuan City 33383, Taiwan, R.O.C.

This report should not be used by the client to claim product certification, approval, or endorsement by TAF or any government agencies.



This report is for your exclusive use. Any copying or replication of this report to or for any other person or entity, or use of our name or trademark, is permitted only with our prior written permission. This report sets forth our findings solely with respect to the test samples identified herein. The results set forth in this report are not indicative or representative of the quality or characteristics of the lot from which a test sample was taken or any similar or identical product unless specifically and expressly noted. Our report includes all of the tests requested by you and the results thereof based upon the information that you provided to us. You have 60 days from date of issuance of this report to notify us of any material error or omission caused by our negligence, provided, however, that such notice shall be in writing and shall specifically address the issue you wish to raise. A failure to raise such issue within the prescribed time shall constitute your unqualified acceptance of the completeness of this report, the tests conducted and the correctness of the report contents. Unless specific mention, the uncertainty of measurement has been explicitly taken into account to declare the compliance or non-compliance to the specification.



TABLE OF CONTENTS

- RELEASE CONTROL RECORD4
- 1. CERTIFICATION.....5
- 2. SUMMARY OF TEST RESULTS6
 - 2.1 MEASUREMENT UNCERTAINTY.....6
- 3. GENERAL INFORMATION7
 - 3.1 GENERAL DESCRIPTION OF EUT7
 - 3.2 DESCRIPTION OF TEST MODES8
 - 3.2.1 TEST MODE APPLICABILITY AND TESTED CHANNEL DETAIL9
 - 3.3 DESCRIPTION OF SUPPORT UNITS11
 - 3.3.1 CONFIGURATION OF SYSTEM UNDER TEST11
 - 3.4 GENERAL DESCRIPTION OF APPLIED STANDARDS12
- 4. TEST TYPES AND RESULTS (FOR BLUETOOTH EDR)13
 - 4.1 RADIATED EMISSION AND BANDEDGE MEASUREMENT13
 - 4.1.1 LIMITS OF RADIATED EMISSION AND BANDEDGE MEASUREMENT13
 - 4.1.2 TEST INSTRUMENTS14
 - 4.1.3 TEST PROCEDURES15
 - 4.1.4 DEVIATION FROM TEST STANDARD15
 - 4.1.5 TEST SETUP16
 - 4.1.6 EUT OPERATING CONDITIONS16
 - 4.1.7 TEST RESULTS.....17
 - 4.2 CONDUCTED EMISSION MEASUREMENT21
 - 4.2.1 LIMITS OF CONDUCTED EMISSION MEASUREMENT21
 - 4.2.2 TEST INSTRUMENTS21
 - 4.2.3 TEST PROCEDURES22
 - 4.2.4 DEVIATION FROM TEST STANDARD22
 - 4.2.5 TEST SETUP23
 - 4.2.6 EUT OPERATING CONDITIONS23
 - 4.2.7 TEST RESULTS.....24
 - 4.3 NUMBER OF HOPPING FREQUENCY USED26
 - 4.3.1 LIMIT OF HOPPING FREQUENCY USED26
 - 4.3.2 TEST SETUP26
 - 4.3.3 TEST INSTRUMENTS26
 - 4.3.4 TEST PROCEDURE26
 - 4.3.5 DEVIATION FROM TEST STANDARD26
 - 4.3.6 TEST RESULTS.....26
 - 4.4 DWELL TIME ON EACH CHANNEL28
 - 4.4.1 LIMITS OF DWELL TIME USED28
 - 4.4.2 TEST SETUP28
 - 4.4.3 TEST INSTRUMENTS28
 - 4.4.4 TEST PROCEDURES28
 - 4.4.5 DEVIATION FROM TEST STANDARD28
 - 4.4.6 TEST RESULTS.....29
 - 4.5 CHANNEL BANDWIDTH32
 - 4.5.1 LIMITS OF CHANNEL BANDWIDTH32
 - 4.5.2 TEST SETUP32
 - 4.5.3 TEST INSTRUMENTS32
 - 4.5.4 TEST PROCEDURE32
 - 4.5.5 DEVIATION FROM TEST STANDARD32
 - 4.5.6 EUT OPERATING CONDITION32
 - 4.5.7 TEST RESULTS.....33
 - 4.6 HOPPING CHANNEL SEPARATION34
 - 4.6.1 LIMITS OF HOPPING CHANNEL SEPARATION34



A D T

| | | |
|-------|------------------------------------------------------------------------------------------|----|
| 4.6.2 | TEST SETUP | 34 |
| 4.6.3 | TEST INSTRUMENTS | 34 |
| 4.6.4 | TEST PROCEDURE | 34 |
| 4.6.5 | DEVIATION FROM TEST STANDARD | 34 |
| 4.6.6 | TEST RESULTS..... | 35 |
| 4.7 | MAXIMUM OUTPUT POWER | 36 |
| 4.7.1 | LIMITS OF MAXIMUM OUTPUT POWER MEASUREMENT | 36 |
| 4.7.2 | TEST SETUP | 36 |
| 4.7.3 | TEST INSTRUMENTS | 36 |
| 4.7.4 | TEST PROCEDURE | 36 |
| 4.7.5 | DEVIATION FROM TEST STANDARD | 36 |
| 4.7.6 | EUT OPERATING CONDITION..... | 36 |
| 4.7.7 | TEST RESULTS..... | 37 |
| 4.8 | CONDUCTED OUT OF BAND EMISSION MEASUREMENT | 38 |
| 4.8.1 | LIMITS OF CONDUCTED OUT OF BAND EMISSION MEASUREMENT | 38 |
| 4.8.2 | TEST INSTRUMENTS..... | 38 |
| 4.8.3 | TEST PROCEDURE | 38 |
| 4.8.4 | DEVIATION FROM TEST STANDARD | 38 |
| 4.8.5 | EUT OPERATING CONDITION..... | 38 |
| 4.8.6 | TEST RESULTS..... | 38 |
| 5. | PHOTOGRAPHS OF THE TEST CONFIGURATION..... | 42 |
| 6. | INFORMATION ON THE TESTING LABORATORIES | 43 |
| 7. | APPENDIX A – MODIFICATIONS RECORDERS FOR ENGINEERING CHANGES TO THE EUT BY THE LAB | 44 |



A D T

RELEASE CONTROL RECORD

| ISSUE NO. | REASON FOR CHANGE | DATE ISSUED |
|-------------|-------------------|---------------|
| RF150727C14 | Original release | Aug. 11, 2015 |



1. CERTIFICATION

PRODUCT: Smartwatch
MODEL NO.: 601
BRAND: Pebble
APPLICANT: Pebble Technology Corporation
TESTED: Aug. 01, 2015 ~ Aug. 05, 2015
TEST SAMPLE: Production Unit
STANDARDS: **FCC Part 15, Subpart C (Section 15.247)**
ANSI C63.10-2013

The above equipment (model: 601) has been tested by **Bureau Veritas Consumer Products Services (H.K.) Ltd., Taoyuan Branch**, and found compliance with the requirement of the above standards. The test record, data evaluation & Equipment Under Test (EUT) configurations represented herein are true and accurate accounts of the measurements of the sample's EMC characteristics under the conditions specified in this report.

PREPARED BY : Rona Chen , **DATE :** Aug. 11, 2015
Rona Chen / Specialist

APPROVED BY : Kay Wu , **DATE :** Aug. 11, 2015
Kay Wu / Supervisor

2. SUMMARY OF TEST RESULTS

The EUT has been tested according to the following specifications:

| APPLIED STANDARD: FCC Part 15, Subpart C (Bluetooth EDR) | | | |
|----------------------------------------------------------|---------------------------------------------------------------------------------------------------------------|--------|------------------------------------------------------------------------------------------------|
| STANDARD SECTION | TEST TYPE AND LIMIT | RESULT | REMARK |
| 15.207 | AC Power Conducted Emission | PASS | Meet the requirement of limit. Minimum passing margin is -8.32dB at 0.18617MHz and 0.17801MHz. |
| 15.247(a)(1) (iii) | Number of Hopping Frequency Used | PASS | Meet the requirement of limit. |
| 15.247(a)(1) (iii) | Dwell Time on Each Channel | PASS | Meet the requirement of limit. |
| 15.247(a)(1) | 1. Hopping Channel Separation 2. Spectrum Bandwidth of a Frequency Hopping Sequence Spread Spectrum System | PASS | Meet the requirement of limit. |
| 15.247(b) | Maximum Peak Output Power | PASS | Meet the requirement of limit. |
| 15.247(d) | Transmitter Radiated Emissions | PASS | Meet the requirement of limit. Minimum passing margin is -4.31dB at 2484MHz. |
| 15.247(d) | Band Edge Measurement | PASS | Meet the requirement of limit. |
| 15.203 | Antenna Requirement | PASS | No antenna connector is used. |

NOTE: If The Frequency Hopping System operating in 2400-2483.5MHz band and the output power less than 125mW. The hopping channel carrier frequencies separated by a minimum of 25kHz or two-thirds of the 20dB bandwidth of hopping channel whichever is greater.

2.1 MEASUREMENT UNCERTAINTY

Where relevant, the following measurement uncertainty levels have been estimated for tests performed on the EUT as specified in CISPR 16-4-2:

| MEASUREMENT | FREQUENCY | UNCERTAINTY |
|---------------------|-----------------|-------------|
| Conducted emissions | 9kHz~30MHz | 2.44 dB |
| Radiated emissions | 30MHz ~ 200MHz | 2.93 dB |
| | 200MHz ~1000MHz | 2.95 dB |
| | 1GHz ~ 18GHz | 2.26 dB |
| | 18GHz ~ 40GHz | 1.94 dB |

This uncertainty represents an expanded uncertainty expressed at approximately the 95% confidence level using a coverage factor of $k = 2$.



3. GENERAL INFORMATION

3.1 GENERAL DESCRIPTION OF EUT

| | | |
|----------------------------|---------------------------------------------|-----------------------------|
| EUT | Smartwatch | |
| MODEL NO. | 601 | |
| POWER SUPPLY | 5.0Vdc (host equipment) 3.8Vdc (battery) | |
| MODULATION TYPE | Bluetooth EDR | GFSK, π /4-DQPSK, 8DPSK |
| TRANSFER RATE | Bluetooth EDR | 1/2/3Mbps |
| OPERATING FREQUENCY | 2402 ~ 2480MHz | |
| NUMBER OF CHANNEL | Bluetooth EDR | 79 |
| CHANNEL SPACING | Bluetooth EDR | 1MHz |
| OUTPUT POWER | Bluetooth EDR | 12.274mW |
| ANTENNA TYPE | PIFA antenna with -10.4dBi gain | |
| ANTENNA CONNECTOR | NA | |
| DATA CABLE | Refer to Note as below | |
| I/O PORTS | Refer to user's manual | |
| ACCESSORY DEVICES | Refer to Note as below | |

NOTE:

1. The EUT contains following accessory devices.

| ITEM | BRAND | MODEL | SPECIFICATION |
|-----------|--------|---------------------|----------------------------|
| Battery | Lishen | 1S1P-SP301618AE-PCM | 3.8Vdc, >=56 mAh |
| USB Cable | Qantas | QT-UP-1M0003A | 1m shielded cable w/o core |

2. The above EUT information is declared by the manufacturer and for more detailed features description, please refer to the manufacturer's specifications or User's Manual.

3.2 DESCRIPTION OF TEST MODES

Bluetooth EDR:

79 channels are provided to this EUT:

| CHANNEL | FREQ. (MHz) | CHANNEL | FREQ. (MHz) | CHANNEL | FREQ. (MHz) | CHANNEL | FREQ. (MHz) |
|---------|-------------|---------|-------------|---------|-------------|---------|-------------|
| 0 | 2402 | 20 | 2422 | 40 | 2442 | 60 | 2462 |
| 1 | 2403 | 21 | 2423 | 41 | 2443 | 61 | 2463 |
| 2 | 2404 | 22 | 2424 | 42 | 2444 | 62 | 2464 |
| 3 | 2405 | 23 | 2425 | 43 | 2445 | 63 | 2465 |
| 4 | 2406 | 24 | 2426 | 44 | 2446 | 64 | 2466 |
| 5 | 2407 | 25 | 2427 | 45 | 2447 | 65 | 2467 |
| 6 | 2408 | 26 | 2428 | 46 | 2448 | 66 | 2468 |
| 7 | 2409 | 27 | 2429 | 47 | 2449 | 67 | 2469 |
| 8 | 2410 | 28 | 2430 | 48 | 2450 | 68 | 2470 |
| 9 | 2411 | 29 | 2431 | 49 | 2451 | 69 | 2471 |
| 10 | 2412 | 30 | 2432 | 50 | 2452 | 70 | 2472 |
| 11 | 2413 | 31 | 2433 | 51 | 2453 | 71 | 2473 |
| 12 | 2414 | 32 | 2434 | 52 | 2454 | 72 | 2474 |
| 13 | 2415 | 33 | 2435 | 53 | 2455 | 73 | 2475 |
| 14 | 2416 | 34 | 2436 | 54 | 2456 | 74 | 2476 |
| 15 | 2417 | 35 | 2437 | 55 | 2457 | 75 | 2477 |
| 16 | 2418 | 36 | 2438 | 56 | 2458 | 76 | 2478 |
| 17 | 2419 | 37 | 2439 | 57 | 2459 | 77 | 2479 |
| 18 | 2420 | 38 | 2440 | 58 | 2460 | 78 | 2480 |
| 19 | 2421 | 39 | 2441 | 59 | 2461 | | |



3.2.1 TEST MODE APPLICABILITY AND TESTED CHANNEL DETAIL

BLUETOOTH EDR

| EUT CONFIGURE MODE | APPLICABLE TO | | | | DESCRIPTION |
|--------------------|---------------|-------|-----|------|-------------|
| | RE≥1G | RE<1G | PLC | APCM | |
| - | √ | √ | √ | √ | - |

Where **RE≥1G**: Radiated Emission above 1GHz **RE<1G**: Radiated Emission below 1GHz
PLC: Power Line Conducted Emission **APCM**: Antenna Port Conducted Measurement

- NOTE:** 1. For Radiated emission test, pre-tested GFSK, π/4-DQPSK, 8DPSK modulation type and found 8DPSK was the worse, therefore chosen for the final test and presented in the test report.
 2. The EUT had been pre-tested on the positioned of each 3 axis. The worst case was found when positioned on **Z-plane**.

RADIATED EMISSION TEST (ABOVE 1GHz):

- Pre-Scan has been conducted to determine the worst-case mode from all possible combinations between available modulations, data rates and antenna ports (if EUT with antenna diversity architecture).
- Following channel(s) was (were) selected for the final test as listed below.

| EUT CONFIGURE MODE | AVAILABLE CHANNEL | TESTED CHANNEL | MODULATION TYPE | PACKET TYPE |
|--------------------|-------------------|----------------|-----------------|-------------|
| - | 0 to 78 | 0, 39, 78 | 8DPSK | DH5 |

RADIATED EMISSION TEST (BELOW 1GHz):

- Pre-Scan has been conducted to determine the worst-case mode from all possible combinations between available modulations, data rates and antenna ports (if EUT with antenna diversity architecture).
- Following channel(s) was (were) selected for the final test as listed below.

| EUT CONFIGURE MODE | AVAILABLE CHANNEL | TESTED CHANNEL | MODULATION TYPE | PACKET TYPE |
|--------------------|-------------------|----------------|-----------------|-------------|
| - | 0 to 78 | 78 | 8DPSK | DH5 |

POWER LINE CONDUCTED EMISSION TEST:

- Pre-Scan has been conducted to determine the worst-case mode from all possible combinations between available modulations, data rates and antenna ports (if EUT with antenna diversity architecture).
- Following channel(s) was (were) selected for the final test as listed below.

| EUT CONFIGURE MODE | AVAILABLE CHANNEL | TESTED CHANNEL | MODULATION TYPE | PACKET TYPE |
|--------------------|-------------------|----------------|-----------------|-------------|
| - | 0 to 78 | 78 | 8DPSK | DH5 |



ANTENNA PORT CONDUCTED MEASUREMENT:

- This item includes all test value of each mode, but only includes spectrum plot of worst value of each mode.
- Pre-Scan has been conducted to determine the worst-case mode from all possible combinations between available modulations, data rates and antenna ports (if EUT with antenna diversity architecture).
- Following channel(s) was (were) selected for the final test as listed below.

| EUT CONFIGURE MODE | AVAILABLE CHANNEL | TESTED CHANNEL | MODULATION TYPE | PACKET TYPE |
|--------------------|-------------------|----------------|-----------------|-------------|
| - | 0 to 78 | 0, 39, 78 | GFSK | DH5 |
| - | 0 to 78 | 0, 39, 78 | $\pi/4$ -DQPSK | DH5 |
| - | 0 to 78 | 0, 39, 78 | 8DPSK | DH5 |

TEST CONDITION:

| APPLICABLE TO | ENVIRONMENTAL CONDITIONS | INPUT POWER | TESTED BY |
|---------------|--------------------------|--------------|-----------|
| RE \geq 1G | 25deg. C, 65%RH | 120Vac, 60Hz | Gavin Wu |
| RE<1G | 25deg. C, 65%RH | 120Vac, 60Hz | Gavin Wu |
| PLC | 25deg. C, 65%RH | 120Vac, 60Hz | Toby Tian |
| APCM | 25deg. C, 65%RH | 3.8Vdc | Wayne Lin |



3.3 DESCRIPTION OF SUPPORT UNITS

The EUT has been tested as an independent unit together with other necessary accessories or support units. The following support units or accessories were used to form a representative test configuration during the tests.

| NO. | PRODUCT | BRAND | MODEL NO. | SERIAL NO. | FCC ID |
|-----|----------|-------|--------------|------------|--------|
| 1 | Notebook | DELL | Inspiron 14R | 9LRKKW1 | N/A |

| NO. | SIGNAL CABLE DESCRIPTION OF THE ABOVE SUPPORT UNITS |
|-----|-----------------------------------------------------|
| 1 | 1m shielded USB cable w/o core |

NOTE: 1. All power cords of the above support units are non shielded (1.8m).

3.3.1 CONFIGURATION OF SYSTEM UNDER TEST

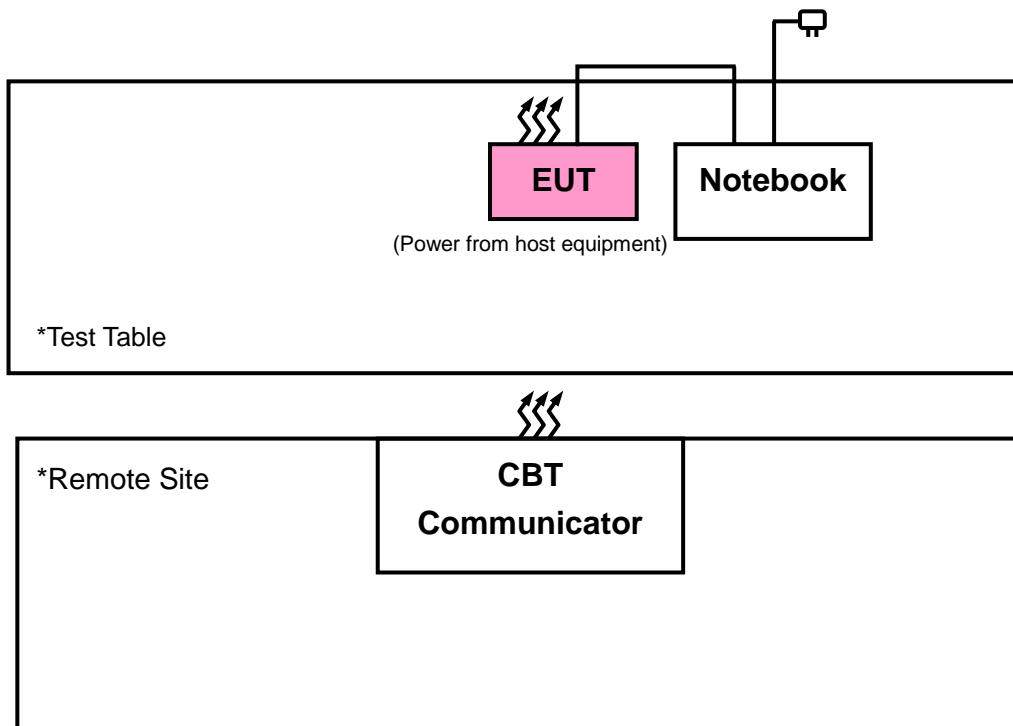



A D T

3.4 GENERAL DESCRIPTION OF APPLIED STANDARDS

The EUT is a RF Product. According to the specifications of the manufacturer, it must comply with the requirements of the following standards:

FCC Part 15, Subpart C (15.247)

ANSI C63.10-2013

FCC Public Notice DA 00-705

All test items have been performed and recorded as per the above standards.

NOTE: The EUT has been verified to comply with the requirements of FCC Part 15, Subpart B, Class B (DoC). The test report has been issued separately.

4. TEST TYPES AND RESULTS (FOR BLUETOOTH EDR)

4.1 RADIATED EMISSION AND BANDEDGE MEASUREMENT

4.1.1 LIMITS OF RADIATED EMISSION AND BANDEDGE MEASUREMENT

Radiated emissions which fall in the restricted bands must comply with the radiated emission limits specified as below table. Other emissions shall be at least 20dB below the highest level of the desired power:

| FREQUENCIES (MHz) | FIELD STRENGTH (microvolts/meter) | MEASUREMENT DISTANCE (meters) |
|-------------------|-----------------------------------|-------------------------------|
| 0.009 ~ 0.490 | 2400/F(kHz) | 300 |
| 0.490 ~ 1.705 | 24000/F(kHz) | 30 |
| 1.705 ~ 30.0 | 30 | 30 |
| 30 ~ 88 | 100 | 3 |
| 88 ~ 216 | 150 | 3 |
| 216 ~ 960 | 200 | 3 |
| Above 960 | 500 | 3 |

NOTE:

1. The lower limit shall apply at the transition frequencies.
2. Emission level (dBuV/m) = 20 log Emission level (uV/m).
3. For frequencies above 1000MHz, the field strength limits are based on average detector, however, the peak field strength of any emission shall not exceed the maximum permitted average limits, specified above by more than 20dB under any condition of modulation.



A D T

4.1.2 TEST INSTRUMENTS

| DESCRIPTION & MANUFACTURER | MODEL NO. | SERIAL NO. | DATE OF CALIBRATION | DUE DATE OF CALIBRATION |
|------------------------------------------------|----------------|---------------------|---------------------|-------------------------|
| Test Receiver Agilent | N9038A | MY51210203 | Jan.21, 2015 | Jan.21, 2016 |
| Spectrum Analyzer Agilent | N9010A | MY52220314 | Sep.03, 2014 | Sep.02, 2015 |
| Spectrum Analyzer ROHDE & SCHWARZ | FSU43 | 101261 | Dec. 10, 2014 | Dec. 09, 2015 |
| BILOG Antenna SCHWARZBECK | VULB9168 | 9168-472 | Feb. 04, 2015 | Feb. 04, 2016 |
| HORN Antenna SCHWARZBECK | BBHA 9120 D | 9120D-969 | Feb. 09, 2015 | Feb. 09, 2016 |
| HORN Antenna SCHWARZBECK | BBHA 9170 | 9170-480 | Feb. 04, 2015 | Feb. 04, 2016 |
| Loop Antenna | EM-6879 | 269 | Aug.13, 2014 | Aug.12, 2015 |
| Preamplifier EMCI | EMC 012645 | 980115 | Dec. 12, 2014 | Dec. 11, 2015 |
| Preamplifier EMCI | EMC 184045 | 980116 | Jan. 09, 2015 | Jan. 08, 2016 |
| Preamplifier EMCI | EMC 330H | 980112 | Dec. 27, 2014 | Dec. 26, 2015 |
| RF signal cable HUBER+SUHNNER | SUCOFLEX 104 | 309219/4 2950114 | Oct. 18, 2014 | Oct. 17, 2015 |
| RF signal cable HUBER+SUHNNER | SUCOFLEX 104 | 250130/4 | Oct. 18, 2014 | Oct. 17, 2015 |
| RF Coaxial Cable Worken | 8D-FB | Cable-Ch10-01 | Nov. 07, 2014 | Nov. 06, 2015 |
| Software BV ADT | E3 6.120103 | NA | NA | NA |
| Antenna Tower MF | MFA-440H | NA | NA | NA |
| Turn Table MF | MFT-201SS | NA | NA | NA |
| Antenna Tower & Turn Table Controller MF | MF-7802 | NA | NA | NA |
| Bluetooth Tester | CBT | 100980 | Apr. 27, 2015 | Apr. 26, 2017 |
| Power Meter Anritsu | ML2495A | 1232002 | Sep. 17, 2014 | Sep. 16, 2015 |
| Power Sensor Anritsu | MA2411B | 1207325 | Sep. 17, 2014 | Sep. 16, 2015 |

- NOTE:**
1. The calibration interval of the above test instruments is 12 months and the calibrations are traceable to NML/ROC and NIST/USA.
 2. The calibration interval of the loop antenna is 24 months and the calibrations are traceable to NML/ROC and NIST/USA.
 3. The test was performed in HwaYa Chamber 10.
 4. The horn antenna and HP preamplifier (model: 8449B) are used only for the measurement of emission frequency above 1GHz if tested.
 5. The FCC Site Registration No. is 690701.
 6. The IC Site Registration No. is IC 7450F-10.

4.1.3 TEST PROCEDURES

- a. The EUT was placed on the top of a rotating table 0.8 meters (for below 1GHz) / 1.5 meters (for above 1GHz) above the ground at 3 meter chamber room for test. The table was rotated 360 degrees to determine the position of the highest radiation.
- b. The EUT was set 3 meters away from the interference-receiving antenna, which was mounted on the top of a variable-height antenna tower.
- c. The antenna is a broadband antenna, and its height is varied from one meter to four meters above the ground to determine the maximum value of the field strength. Both horizontal and vertical polarizations of the antenna are set to make the measurement.
- d. For each suspected emission, the EUT was arranged to its worst case and then the antenna was tuned to heights from 1 meter to 4 meters and the rotatable table was turned from 0 degrees to 360 degrees to find the maximum reading.
- e. The test-receiver system was set to Peak Detect Function and Specified Bandwidth with Maximum Hold Mode.
- f. If the emission level of the EUT in peak mode was lower than the limit specified, then testing could be stopped and the peak values of the EUT would be reported. Otherwise the emissions would be re-tested one by one using peak, quasi-peak or average method as specified and then reported in a data sheet.

NOTE:

1. The resolution bandwidth and video bandwidth of test receiver/spectrum analyzer is 120kHz for Quasi-peak detection at frequency below 1GHz.
2. The resolution bandwidth of test receiver/spectrum analyzer is 1MHz and video bandwidth is 3MHz for Peak detection at frequency above 1GHz.
3. The resolution bandwidth of test receiver/spectrum analyzer is 1MHz and the video bandwidth is 10Hz for Average detection (AV) at frequency above 1GHz.

4.1.4 DEVIATION FROM TEST STANDARD

No deviation.

4.1.5 TEST SETUP

<Frequency Range 30MHz ~ 1GHz>

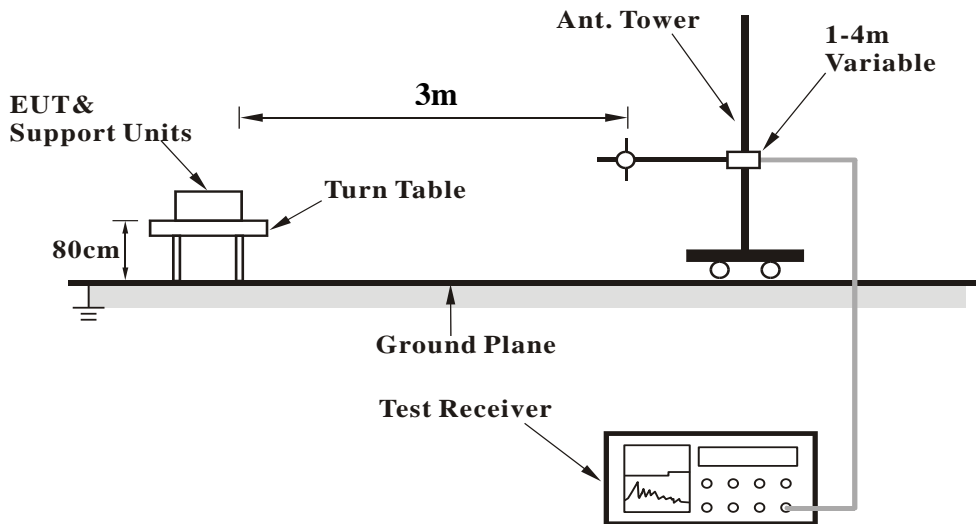

<Frequency Range above 1GHz>

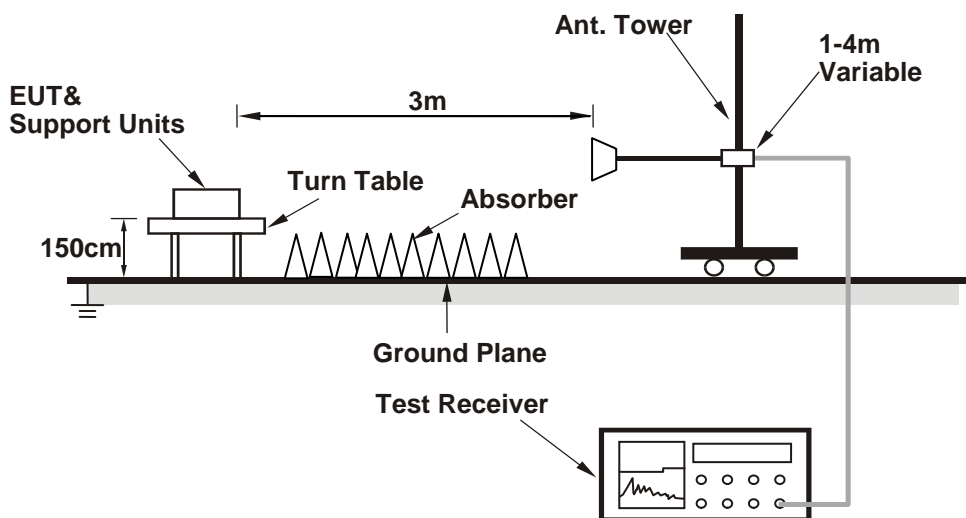

For the actual test configuration, please refer to the attached file (Test Setup Photo).

4.1.6 EUT OPERATING CONDITIONS

- a. Placed the EUT on a testing table.
- b. Use the software to control the EUT under transmission condition continuously at specific channel frequency.



A D T

4.1.7 TEST RESULTS

ABOVE 1GHz WORST-CASE DATA

8DPSK

| EUT TEST CONDITION | | MEASUREMENT DETAIL | |
|--------------------------|-----------------|--------------------|---------------------------|
| CHANNEL | Channel 0 | FREQUENCY RANGE | 1GHz ~ 25GHz |
| INPUT POWER | 120Vac, 60 Hz | DETECTOR FUNCTION | Peak (PK) Average (AV) |
| ENVIRONMENTAL CONDITIONS | 25deg. C, 65%RH | TESTED BY | Gavin Wu |

| ANTENNA POLARITY & TEST DISTANCE: HORIZONTAL AT 3 M | | | | | | | | | | |
|-----------------------------------------------------|-------------------------|-------------------|----------------|-------------|-----------------------|-----------------|--------------------|---------------------|----------------------|---------|
| FREQ. (MHz) | EMISSION LEVEL (dBuV/m) | READ LEVEL (dBuV) | LIMIT (dBuV/m) | MARGIN (dB) | ANTENNA FACTOR (dB/m) | CABLE LOSS (dB) | PREAMP FACTOR (dB) | ANTENNA HEIGHT (cm) | TABLE ANGLE (Degree) | REMARK |
| 2378 | 35.24 | 41.81 | 54 | -18.76 | 26.86 | 4.07 | 37.5 | 138 | 31 | Average |
| 2378 | 59.99 | 66.56 | 74 | -14.01 | 26.86 | 4.07 | 37.5 | 138 | 31 | Peak |
| 2402 | 88.36 | 94.88 | | | 26.91 | 4.09 | 37.52 | 138 | 31 | Average |
| 2402 | 103.11 | 109.63 | | | 26.91 | 4.09 | 37.52 | 138 | 31 | Peak |
| 2494 | 33.63 | 39.52 | 54 | -20.37 | 27.2 | 4.16 | 37.25 | 138 | 31 | Average |
| 2494 | 58.27 | 64.16 | 74 | -15.73 | 27.2 | 4.16 | 37.25 | 138 | 31 | Peak |
| 4804 | 42.46 | 57.8 | 54 | -11.54 | 30.97 | 6.79 | 53.1 | 212 | 34 | Average |
| 4804 | 52.59 | 67.93 | 74 | -21.41 | 30.97 | 6.79 | 53.1 | 212 | 34 | Peak |
| ANTENNA POLARITY & TEST DISTANCE: VERTICAL AT 3 M | | | | | | | | | | |
| FREQ. (MHz) | EMISSION LEVEL (dBuV/m) | READ LEVEL (dBuV) | LIMIT (dBuV/m) | MARGIN (dB) | ANTENNA FACTOR (dB/m) | CABLE LOSS (dB) | PREAMP FACTOR (dB) | ANTENNA HEIGHT (cm) | TABLE ANGLE (Degree) | REMARK |
| 2312 | 33.3 | 40.05 | 54 | -20.7 | 26.67 | 4.03 | 37.45 | 212 | 38 | Average |
| 2312 | 57.05 | 63.8 | 74 | -16.95 | 26.67 | 4.03 | 37.45 | 212 | 38 | Peak |
| 2402 | 83.13 | 89.65 | | | 26.91 | 4.09 | 37.52 | 212 | 38 | Average |
| 2402 | 96.47 | 102.99 | | | 26.91 | 4.09 | 37.52 | 212 | 38 | Peak |
| 2500 | 33.62 | 39.51 | 54 | -20.38 | 27.2 | 4.16 | 37.25 | 212 | 38 | Average |
| 2500 | 56.89 | 62.78 | 74 | -17.11 | 27.2 | 4.16 | 37.25 | 212 | 38 | Peak |
| 4804 | 41.97 | 57.31 | 54 | -12.03 | 30.97 | 6.79 | 53.1 | 199 | 28 | Average |
| 4804 | 52.15 | 67.49 | 74 | -21.85 | 30.97 | 6.79 | 53.1 | 199 | 28 | Peak |

REMARKS:

- Emission Level = Read Level + Antenna Factor + Cable Loss - Preamp Factor
Margin value = Emission level – Limit value
- 2402MHz: Fundamental frequency.



A D T

| EUT TEST CONDITION | | MEASUREMENT DETAIL | |
|--------------------------|-----------------|--------------------|---------------------------|
| CHANNEL | Channel 39 | FREQUENCY RANGE | 1GHz ~ 25GHz |
| INPUT POWER | 120Vac, 60 Hz | DETECTOR FUNCTION | Peak (PK) Average (AV) |
| ENVIRONMENTAL CONDITIONS | 25deg. C, 65%RH | TESTED BY | Gavin Wu |

ANTENNA POLARITY & TEST DISTANCE: HORIZONTAL AT 3 M

| FREQ. (MHz) | EMISSION LEVEL (dBuV/m) | READ LEVEL (dBuV) | LIMIT (dBuV/m) | MARGIN (dB) | ANTENNA FACTOR (dB/m) | CABLE LOSS (dB) | PREAMP FACTOR (dB) | ANTENNA HEIGHT (cm) | TABLE ANGLE (Degree) | REMARK |
|-------------|-------------------------|-------------------|----------------|-------------|-----------------------|-----------------|--------------------|---------------------|----------------------|---------|
| 2378 | 33.25 | 39.82 | 54 | -20.75 | 26.86 | 4.07 | 37.5 | 104 | 34 | Average |
| 2378 | 58.2 | 64.77 | 74 | -15.8 | 26.86 | 4.07 | 37.5 | 104 | 34 | Peak |
| 2441 | 89.19 | 95.4 | | | 27.06 | 4.12 | 37.39 | 104 | 34 | Average |
| 2441 | 103.77 | 109.98 | | | 27.06 | 4.12 | 37.39 | 104 | 34 | Peak |
| 2488 | 33.76 | 39.72 | 54 | -20.24 | 27.2 | 4.16 | 37.32 | 104 | 34 | Average |
| 2488 | 57.63 | 63.59 | 74 | -16.37 | 27.2 | 4.16 | 37.32 | 104 | 34 | Peak |
| 4882 | 41.56 | 56.7 | 54 | -12.44 | 31.06 | 6.85 | 53.05 | 118 | 8 | Average |
| 4882 | 52.33 | 67.47 | 74 | -21.67 | 31.06 | 6.85 | 53.05 | 118 | 8 | Peak |

ANTENNA POLARITY & TEST DISTANCE: VERTICAL AT 3 M

| FREQ. (MHz) | EMISSION LEVEL (dBuV/m) | READ LEVEL (dBuV) | LIMIT (dBuV/m) | MARGIN (dB) | ANTENNA FACTOR (dB/m) | CABLE LOSS (dB) | PREAMP FACTOR (dB) | ANTENNA HEIGHT (cm) | TABLE ANGLE (Degree) | REMARK |
|-------------|-------------------------|-------------------|----------------|-------------|-----------------------|-----------------|--------------------|---------------------|----------------------|---------|
| 2368 | 33.02 | 39.64 | 54 | -20.98 | 26.81 | 4.07 | 37.5 | 209 | 49 | Average |
| 2368 | 56.65 | 63.27 | 74 | -17.35 | 26.81 | 4.07 | 37.5 | 209 | 49 | Peak |
| 2441 | 83.7 | 89.91 | | | 27.06 | 4.12 | 37.39 | 209 | 49 | Average |
| 2441 | 97.01 | 103.22 | | | 27.06 | 4.12 | 37.39 | 209 | 49 | Peak |
| 2486 | 33.55 | 39.57 | 54 | -20.45 | 27.15 | 4.15 | 37.32 | 209 | 49 | Average |
| 2486 | 56.92 | 62.94 | 74 | -17.08 | 27.15 | 4.15 | 37.32 | 209 | 49 | Peak |
| 4882 | 41.23 | 56.37 | 54 | -12.77 | 31.06 | 6.85 | 53.05 | 204 | 16 | Average |
| 4882 | 52.69 | 67.83 | 74 | -21.31 | 31.06 | 6.85 | 53.05 | 204 | 16 | Peak |

REMARKS:

- Emission Level = Read Level + Antenna Factor + Cable Loss - Preamp Factor
Margin value = Emission level – Limit value
- 2441MHz: Fundamental frequency.



A D T

| EUT TEST CONDITION | | MEASUREMENT DETAIL | |
|--------------------------|-----------------|--------------------|---------------------------|
| CHANNEL | Channel 78 | FREQUENCY RANGE | 1GHz ~ 25GHz |
| INPUT POWER | 120Vac, 60 Hz | DETECTOR FUNCTION | Peak (PK) Average (AV) |
| ENVIRONMENTAL CONDITIONS | 25deg. C, 65%RH | TESTED BY | Gavin Wu |

ANTENNA POLARITY & TEST DISTANCE: HORIZONTAL AT 3 M

| FREQ. (MHz) | EMISSION LEVEL (dBuV/m) | READ LEVEL (dBuV) | LIMIT (dBuV/m) | MARGIN (dB) | ANTENNA FACTOR (dB/m) | CABLE LOSS (dB) | PREAMP FACTOR (dB) | ANTENNA HEIGHT (cm) | TABLE ANGLE (Degree) | REMARK |
|-------------|-------------------------|-------------------|----------------|--------------|-----------------------|-----------------|--------------------|---------------------|----------------------|-------------|
| 2384 | 33.16 | 39.72 | 54 | -20.84 | 26.86 | 4.08 | 37.5 | 134 | 26 | Average |
| 2384 | 56.43 | 62.99 | 74 | -17.57 | 26.86 | 4.08 | 37.5 | 134 | 26 | Peak |
| 2480 | 87.85 | 93.87 | | | 27.15 | 4.15 | 37.32 | 134 | 26 | Average |
| 2480 | 102.81 | 108.83 | | | 27.15 | 4.15 | 37.32 | 134 | 26 | Peak |
| 2484 | 42.42 | 48.44 | 54 | -11.58 | 27.15 | 4.15 | 37.32 | 134 | 26 | Average |
| 2484 | 69.69 | 75.71 | 74 | -4.31 | 27.15 | 4.15 | 37.32 | 134 | 26 | Peak |
| 4960 | 41.8 | 56.77 | 54 | -12.2 | 31.16 | 6.91 | 53.04 | 126 | 5 | Average |
| 4960 | 52.53 | 67.5 | 74 | -21.47 | 31.16 | 6.91 | 53.04 | 126 | 5 | Peak |

ANTENNA POLARITY & TEST DISTANCE: VERTICAL AT 3 M

| FREQ. (MHz) | EMISSION LEVEL (dBuV/m) | READ LEVEL (dBuV) | LIMIT (dBuV/m) | MARGIN (dB) | ANTENNA FACTOR (dB/m) | CABLE LOSS (dB) | PREAMP FACTOR (dB) | ANTENNA HEIGHT (cm) | TABLE ANGLE (Degree) | REMARK |
|-------------|-------------------------|-------------------|----------------|-------------|-----------------------|-----------------|--------------------|---------------------|----------------------|---------|
| 2374 | 33 | 39.57 | 54 | -21 | 26.86 | 4.07 | 37.5 | 204 | 42 | Average |
| 2374 | 56.69 | 63.26 | 74 | -17.31 | 26.86 | 4.07 | 37.5 | 204 | 42 | Peak |
| 2480 | 82.05 | 88.07 | | | 27.15 | 4.15 | 37.32 | 204 | 42 | Average |
| 2480 | 95.81 | 101.83 | | | 27.15 | 4.15 | 37.32 | 204 | 42 | Peak |
| 2484 | 38.41 | 44.43 | 54 | -15.59 | 27.15 | 4.15 | 37.32 | 204 | 42 | Average |
| 2484 | 66.67 | 72.69 | 74 | -7.33 | 27.15 | 4.15 | 37.32 | 204 | 42 | Peak |
| 4960 | 41.65 | 56.62 | 54 | -12.35 | 31.16 | 6.91 | 53.04 | 205 | 22 | Average |
| 4960 | 52.69 | 67.66 | 74 | -21.31 | 31.16 | 6.91 | 53.04 | 205 | 22 | Peak |

REMARKS:

- Emission Level = Read Level + Antenna Factor + Cable Loss - Preamp Factor
Margin value = Emission level – Limit value
- 2480MHz: Fundamental frequency.



A D T

BELOW 1GHz WORST-CASE DATA:

| EUT TEST CONDITION | | MEASUREMENT DETAIL | |
|--------------------------|-----------------|--------------------|--------------|
| CHANNEL | Channel 78 | FREQUENCY RANGE | 30MHz ~ 1GHz |
| INPUT POWER | 120Vac, 60 Hz | DETECTOR FUNCTION | Peak (PK) |
| ENVIRONMENTAL CONDITIONS | 25deg. C, 65%RH | TESTED BY | Gavin Wu |

ANTENNA POLARITY & TEST DISTANCE: HORIZONTAL AT 3 M

| FREQ. (MHz) | EMISSION LEVEL (dBuV/m) | READ LEVEL (dBuV) | LIMIT (dBuV/m) | MARGIN (dB) | ANTENNA FACTOR (dB/m) | CABLE LOSS (dB) | PREAMP FACTOR (dB) | ANTENNA HEIGHT (cm) | TABLE ANGLE (Degree) | REMARK |
|-------------|-------------------------|-------------------|----------------|-------------|-----------------------|-----------------|--------------------|---------------------|----------------------|--------|
| 76.44 | 30.88 | 52.55 | 40 | -9.12 | 9.09 | 0.86 | 31.62 | 119 | 87 | Peak |
| 228.99 | 29.98 | 49.84 | 46 | -16.02 | 10.58 | 1.41 | 31.85 | 116 | 6 | Peak |
| 267.33 | 28.52 | 46.97 | 46 | -17.48 | 12 | 1.54 | 31.99 | 123 | 163 | Peak |
| 305.6 | 34.19 | 51.36 | 46 | -11.81 | 13.08 | 1.65 | 31.9 | 133 | 272 | Peak |
| 395.9 | 27.31 | 42.26 | 46 | -18.69 | 15.24 | 1.9 | 32.09 | 102 | 17 | Peak |
| 498.8 | 29.63 | 41.9 | 46 | -16.37 | 17.29 | 2.09 | 31.65 | 101 | 51 | Peak |

ANTENNA POLARITY & TEST DISTANCE: VERTICAL AT 3 M

| FREQ. (MHz) | EMISSION LEVEL (dBuV/m) | READ LEVEL (dBuV) | LIMIT (dBuV/m) | MARGIN (dB) | ANTENNA FACTOR (dB/m) | CABLE LOSS (dB) | PREAMP FACTOR (dB) | ANTENNA HEIGHT (cm) | TABLE ANGLE (Degree) | REMARK |
|-------------|-------------------------|-------------------|----------------|-------------|-----------------------|-----------------|--------------------|---------------------|----------------------|--------|
| 30 | 23.33 | 41.91 | 40 | -16.67 | 11.98 | 0.58 | 31.14 | 120 | 185 | Peak |
| 76.44 | 22.29 | 43.96 | 40 | -17.71 | 9.09 | 0.86 | 31.62 | 121 | 9 | Peak |
| 157.71 | 20.84 | 38.81 | 43.5 | -22.66 | 12.73 | 1.13 | 31.83 | 118 | 175 | Peak |
| 305.6 | 29.43 | 46.6 | 46 | -16.57 | 13.08 | 1.65 | 31.9 | 136 | 243 | Peak |
| 498.8 | 29.94 | 42.21 | 46 | -16.06 | 17.29 | 2.09 | 31.65 | 106 | 138 | Peak |
| 594 | 30.78 | 41.26 | 46 | -15.22 | 19.46 | 2.24 | 32.18 | 117 | 225 | Peak |

REMARKS: Emission Level = Read Level + Antenna Factor + Cable Loss - Preamp Factor
 Margin value = Emission level – Limit value



4.2 CONDUCTED EMISSION MEASUREMENT

4.2.1 LIMITS OF CONDUCTED EMISSION MEASUREMENT

| FREQUENCY OF EMISSION (MHz) | CONDUCTED LIMIT (dB μ V) | |
|-----------------------------|------------------------------|----------|
| | Quasi-peak | Average |
| 0.15 ~ 0.5 | 66 to 56 | 56 to 46 |
| 0.5 ~ 5 | 56 | 46 |
| 5 ~ 30 | 60 | 50 |

- NOTE:**
1. The lower limit shall apply at the transition frequencies.
 2. The limit decreases in line with the logarithm of the frequency in the range of 0.15 to 0.50MHz.
 3. All emanations from a class A/B digital device or system, including any network of conductors and apparatus connected thereto, shall not exceed the level of field strengths specified above.

4.2.2 TEST INSTRUMENTS

| DESCRIPTION & MANUFACTURER | MODEL NO. | SERIAL NO. | DATE OF CALIBRATION | DUE DATE OF CALIBRATION |
|-----------------------------------------|--------------------------|----------------|---------------------|-------------------------|
| Test Receiver ROHDE & SCHWARZ | ESCI | 100613 | Nov. 11, 2014 | Nov. 10, 2015 |
| RF signal cable Woken | 5D-FB | Cable-HYC01-01 | Dec. 26, 2014 | Dec. 25, 2015 |
| LISN ROHDE & SCHWARZ (EUT) | ESH3-Z5 | 835239/001 | Feb. 26, 2015 | Feb. 25, 2016 |
| LISN ROHDE & SCHWARZ (Peripheral) | ESH3-Z5 | 100311 | Jul. 24, 2015 | Jul. 23, 2016 |
| Software ADT | BV ADT_Cond_ V7.3.7.3 | NA | NA | NA |

- NOTE:**
1. The calibration interval of the above test instruments is 12 months and the calibrations are traceable to NML/ROC and NIST/USA.
 2. The test was performed in HwaYa Shielded Room 1.
 3. The VCCI Site Registration No. is C-2047.



A D T

4.2.3 TEST PROCEDURES

- a. The EUT was placed 0.4 meters from the conducting wall of the shielded room with EUT being connected to the power mains through a line impedance stabilization network (LISN). Other support units were connected to the power mains through another LISN. The two LISNs provide 50 ohm/ 50uH of coupling impedance for the measuring instrument.
- b. Both lines of the power mains connected to the EUT were checked for maximum conducted interference.
- c. The frequency range from 150kHz to 30MHz was searched. Emission levels under (Limit - 20dB) was not recorded.

NOTE: All modes of operation were investigated and the worst-case emissions are reported.

4.2.4 DEVIATION FROM TEST STANDARD

No deviation.

4.2.5 TEST SETUP

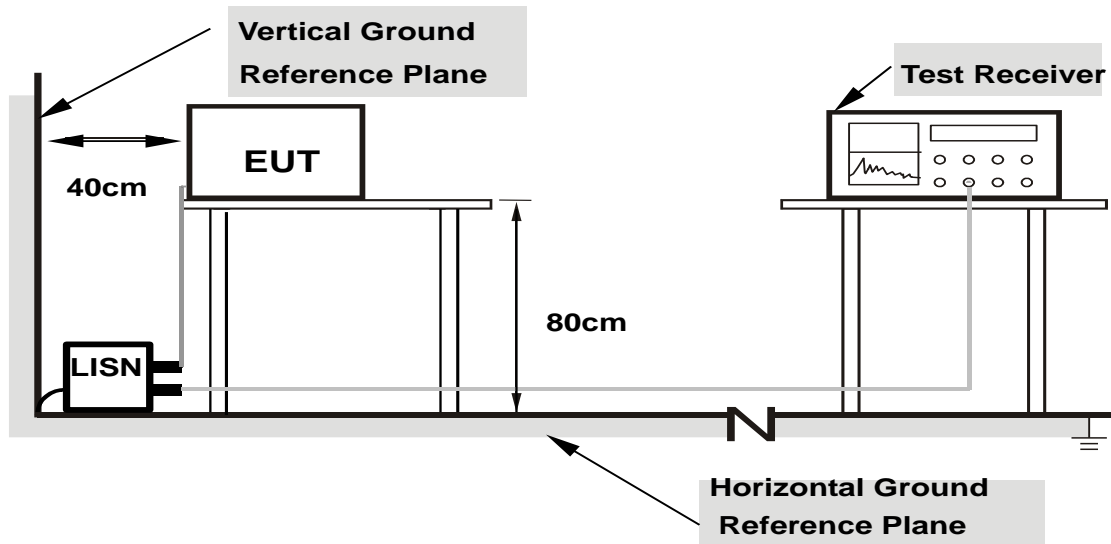

- Note: 1.Support units were connected to second LISN.**
2.Both of LISNs (AMN) are 80 cm from EUT and at least 80 from other units and other metal planes

For the actual test configuration, please refer to the attached file (Test Setup Photo).

4.2.6 EUT OPERATING CONDITIONS

Same as section 4.1.6.

4.2.7 TEST RESULTS

CONDUCTED WORST-CASE DATA :

| | | | |
|--------------|--------|----------------------|------|
| PHASE | Line 1 | 6dB BANDWIDTH | 9kHz |
|--------------|--------|----------------------|------|

| Phase Of Power : Line (L) | | | | | | | | | | |
|---------------------------|-----------------|------------------------|----------------------|--------------|-----------------------|--------------|--------------|--------------|--------------|---------------|
| No | Frequency (MHz) | Correction Factor (dB) | Reading Value (dBuV) | | Emission Level (dBuV) | | Limit (dBuV) | | Margin (dB) | |
| | | | Q.P. | AV. | Q.P. | AV. | Q.P. | AV. | Q.P. | AV. |
| 1 | 0.18617 | 0.06 | 55.83 | 43.13 | 55.89 | 43.19 | 64.21 | 54.21 | -8.32 | -11.02 |
| 2 | 0.24600 | 0.06 | 47.31 | 36.81 | 47.37 | 36.87 | 61.89 | 51.89 | -14.52 | -15.02 |
| 3 | 0.31000 | 0.06 | 38.97 | 28.42 | 39.03 | 28.48 | 59.97 | 49.97 | -20.94 | -21.49 |
| 4 | 0.40600 | 0.06 | 30.30 | 16.81 | 30.36 | 16.87 | 57.73 | 47.73 | -27.37 | -30.86 |
| 5 | 0.49400 | 0.06 | 33.15 | 22.72 | 33.21 | 22.78 | 56.10 | 46.10 | -22.89 | -23.32 |
| 6 | 1.62767 | 0.11 | 31.40 | 21.67 | 31.51 | 21.78 | 56.00 | 46.00 | -24.49 | -24.22 |

Remarks:

1. Q.P. and AV. are abbreviations of quasi-peak and average individually.
2. The emission levels of other frequencies were very low against the limit.
3. Margin value = Emission level – Limit value
4. Correction factor = Insertion loss + Cable loss
5. Emission Level = Correction Factor + Reading Value

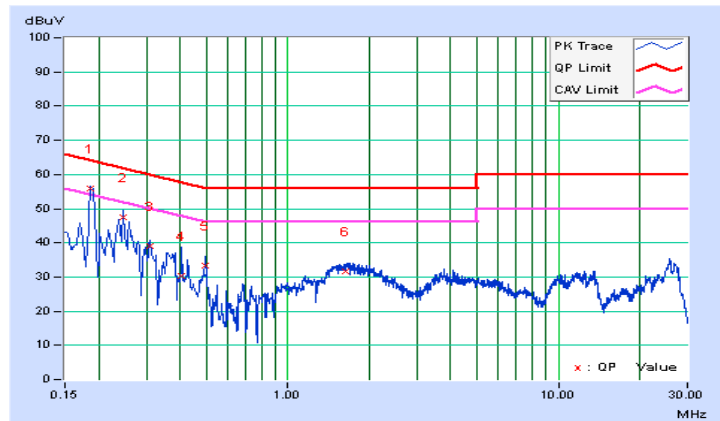



A D T

| | | | |
|--------------|--------|----------------------|------|
| PHASE | Line 2 | 6dB BANDWIDTH | 9kHz |
|--------------|--------|----------------------|------|

| Phase Of Power : Neutral (N) | | | | | | | | | | |
|------------------------------|-----------------|------------------------|----------------------|--------------|-----------------------|--------------|--------------|--------------|--------------|---------------|
| No | Frequency (MHz) | Correction Factor (dB) | Reading Value (dBuV) | | Emission Level (dBuV) | | Limit (dBuV) | | Margin (dB) | |
| | | | Q.P. | AV. | Q.P. | AV. | Q.P. | AV. | Q.P. | AV. |
| 1 | 0.15000 | 0.05 | 38.95 | 29.30 | 39.00 | 29.35 | 66.00 | 56.00 | -27.00 | -26.65 |
| 2 | 0.17801 | 0.05 | 56.21 | 42.84 | 56.26 | 42.89 | 64.58 | 54.58 | -8.32 | -11.69 |
| 3 | 0.19000 | 0.05 | 50.72 | 33.49 | 50.77 | 33.54 | 64.04 | 54.04 | -13.27 | -20.50 |
| 4 | 0.24164 | 0.05 | 47.82 | 35.76 | 47.87 | 35.81 | 62.04 | 52.04 | -14.17 | -16.23 |
| 5 | 0.26221 | 0.05 | 38.61 | 24.77 | 38.66 | 24.82 | 61.36 | 51.36 | -22.70 | -26.54 |
| 6 | 0.29000 | 0.05 | 37.57 | 25.75 | 37.62 | 25.80 | 60.52 | 50.52 | -22.90 | -24.72 |

Remarks:

1. Q.P. and AV. are abbreviations of quasi-peak and average individually.
2. The emission levels of other frequencies were very low against the limit.
3. Margin value = Emission level – Limit value
4. Correction factor = Insertion loss + Cable loss
5. Emission Level = Correction Factor + Reading Value

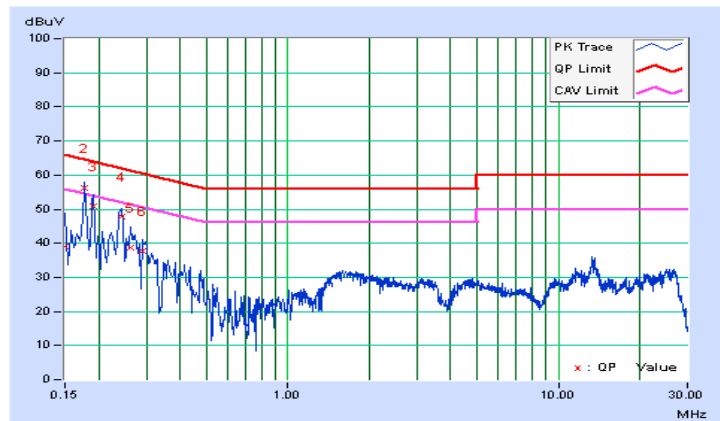

4.3 NUMBER OF HOPPING FREQUENCY USED

4.3.1 LIMIT OF HOPPING FREQUENCY USED

At least 15 channels frequencies, and should be equally spaced.

4.3.2 TEST SETUP

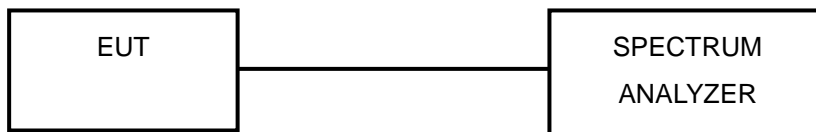

4.3.3 TEST INSTRUMENTS

Refer to section 4.1.2 to get information of above instrument.

4.3.4 TEST PROCEDURE

- Check the calibration of the measuring instrument (SA) using either an internal calibrator or a known signal from an external generator.
- Turn on the EUT and connect its antenna terminal to measurement via a low loss cable. Then set it to any one measured frequency within its operating range and make sure the instrument is operated in its linear range.
- Set the SA on MaxHold Mode, and then keep the EUT in hopping mode. Record all the signals from each channel until each one has been recorded.
- Set the SA on View mode and then plot the result on SA screen.
- Repeat above procedures until all frequencies measured were complete.

4.3.5 DEVIATION FROM TEST STANDARD

No deviation.

4.3.6 TEST RESULTS

There are 79 hopping frequencies in the hopping mode. Please refer to next page for the test result. On the plot, it shows that the hopping frequencies are equally spaced.



A D T

8DPSK

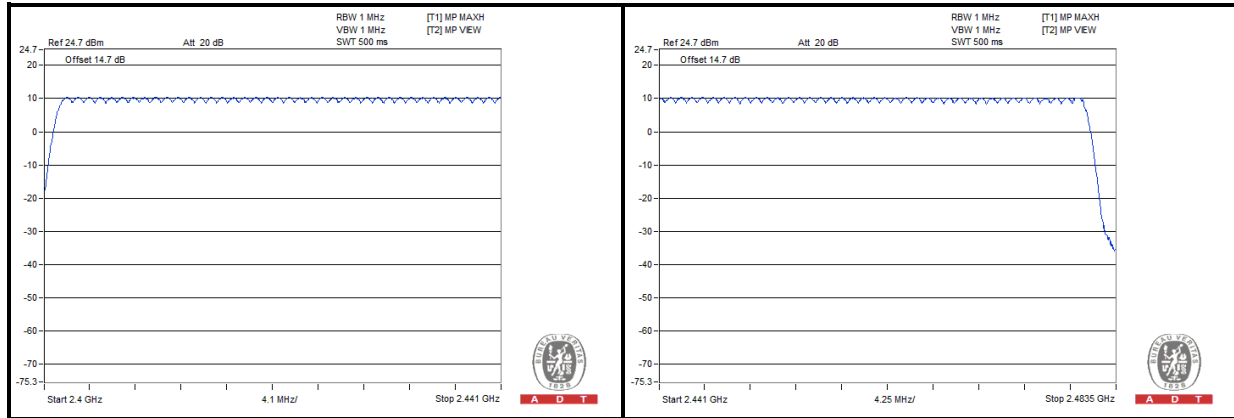

4.4 DWELL TIME ON EACH CHANNEL

4.4.1 LIMITS OF DWELL TIME USED

The average time of occupancy on any channel shall not be greater than 0.4 seconds within a period of 0.4 seconds multiplied by the number of hopping channels employed.

4.4.2 TEST SETUP

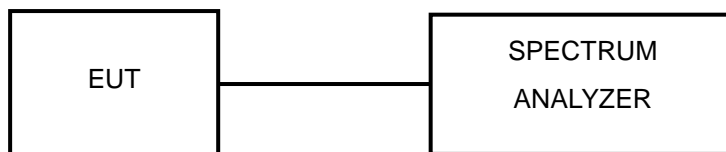

4.4.3 TEST INSTRUMENTS

Refer to section 4.1.2 to get information of above instrument.

4.4.4 TEST PROCEDURES

- Check the calibration of the measuring instrument (SA) using either an internal calibrator or a known signal from an external generator.
- Turn on the EUT and connect its antenna terminal to measurement via a low loss cable. Then set it to any one measured frequency within its operating range and make sure the instrument is operated in its linear range.
- Adjust the center frequency of SA on any frequency be measured and set SA to zero span mode. And then, set RBW and VBW of spectrum analyzer to proper value.
- Measure the time duration of one transmission on the measured frequency. And then plot the result with time difference of this time duration.
- Repeat above procedures until all different time-slot modes have been completed.

4.4.5 DEVIATION FROM TEST STANDARD

No deviation.



A D T

4.4.6 TEST RESULTS

GFSK

| Mode | Average Hopping Channel | Package Transfer Time (usec) | Result (sec) | Limit (sec) |
|------|-------------------------|------------------------------|--------------|-------------|
| DH1 | 10.00 | 441.00 | 0.14 | 0.4 |
| DH3 | 5.00 | 1710.00 | 0.27 | 0.4 |
| DH5 | 3.40 | 2970.00 | 0.32 | 0.4 |

NOTE:

1. Dwell Time=79(channels) x 0.4(s) x average hopping channel x package transfer time
2. 79 channels come from the Hopping Channel number
3. Average Hopping Channel = hops/sweep time
4. t: Package Transfer Time(us)
5. Test plots of the transmitting time slot are shown as below.

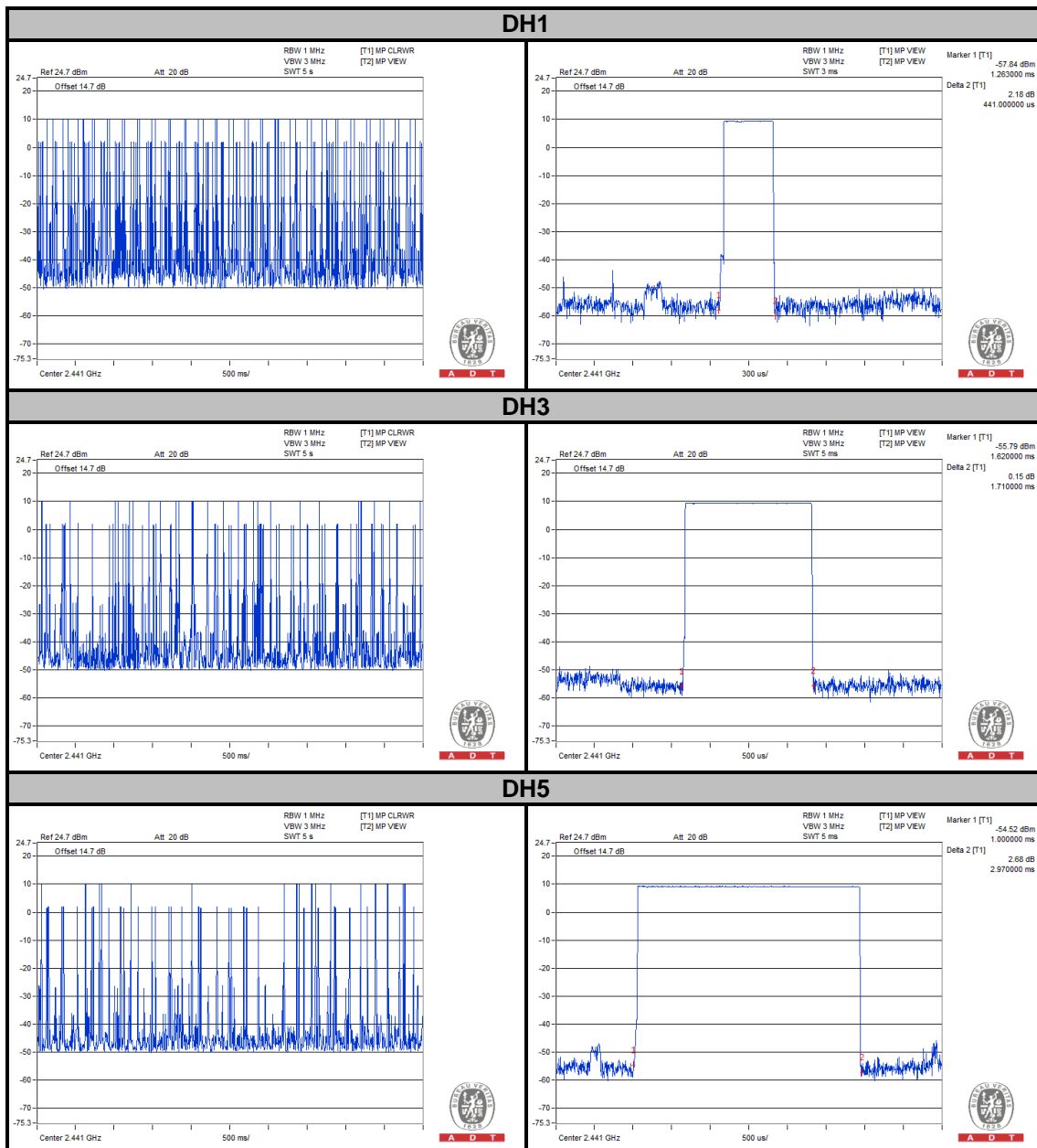



A D T

π/4-DQPSK

| Mode | Average Hopping Channel | Package Transfer Time (usec) | Result (sec) | Limit (sec) |
|------|-------------------------|------------------------------|--------------|-------------|
| 2DH1 | 10.20 | 441.00 | 0.14 | 0.4 |
| 2DH3 | 5.20 | 1710.00 | 0.28 | 0.4 |
| 2DH5 | 3.20 | 2950.00 | 0.30 | 0.4 |

NOTE:

1. Dwell Time=79(channels) x 0.4(s) x average hopping channel x package transfer time
2. 79 channels come from the Hopping Channel number
3. Average Hopping Channel = hops/sweep time
4. t: Package Transfer Time(us)
5. Test plots of the transmitting time slot are shown as below.

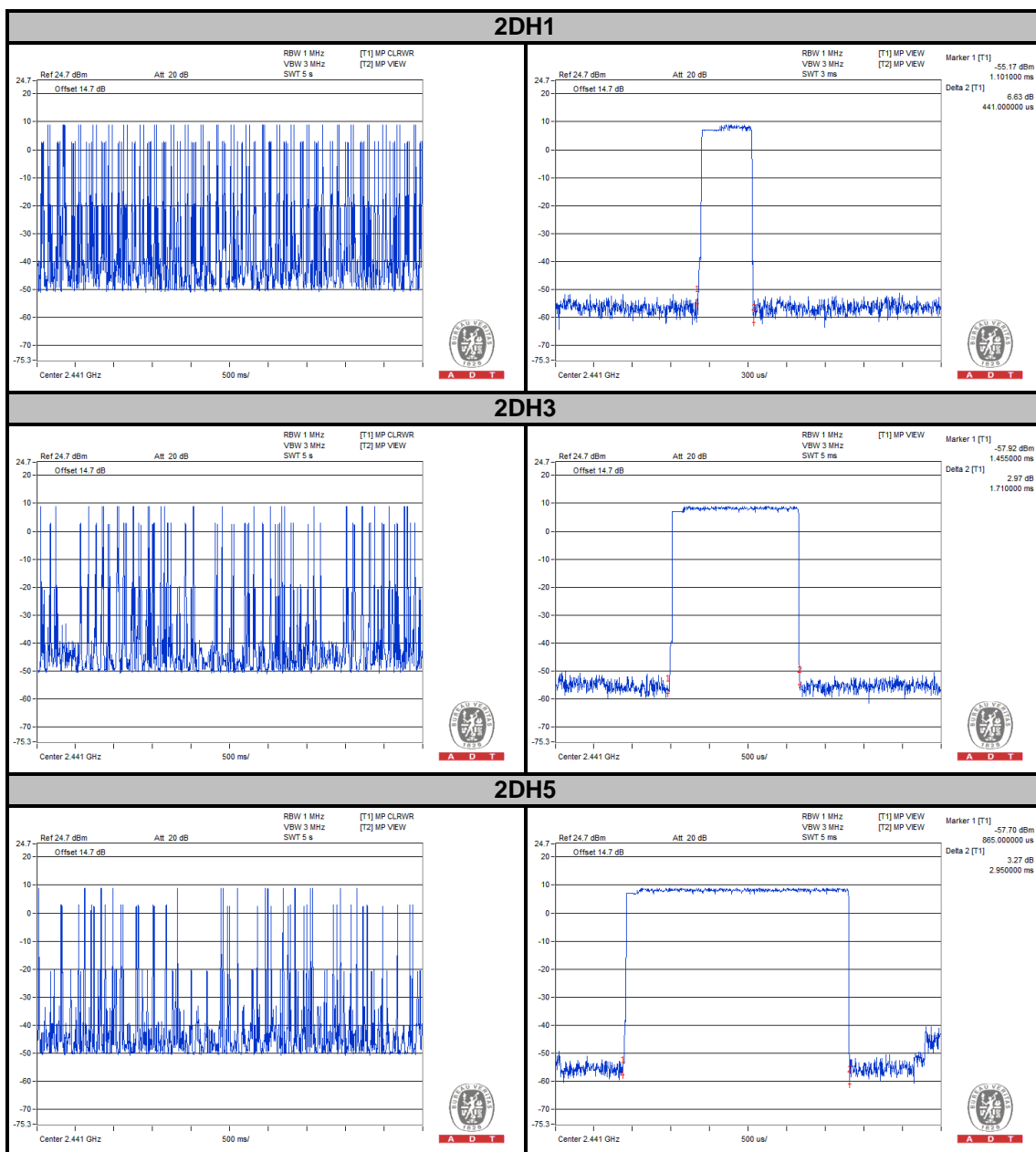



A D T

8DPSK

| Mode | Average Hopping Channel | Package Transfer Time (usec) | Result (sec) | Limit (sec) |
|------|-------------------------|------------------------------|--------------|-------------|
| 3DH1 | 10.00 | 438.00 | 0.14 | 0.4 |
| 3DH3 | 5.00 | 1695.00 | 0.27 | 0.4 |
| 3DH5 | 3.20 | 2975.00 | 0.30 | 0.4 |

NOTE:

1. Dwell Time=79(channels) x 0.4(s) x average hopping channel x package transfer time
2. 79 channels come from the Hopping Channel number
3. Average Hopping Channel = hops/sweep time
4. t: Package Transfer Time(us)
5. Test plots of the transmitting time slot are shown as below.

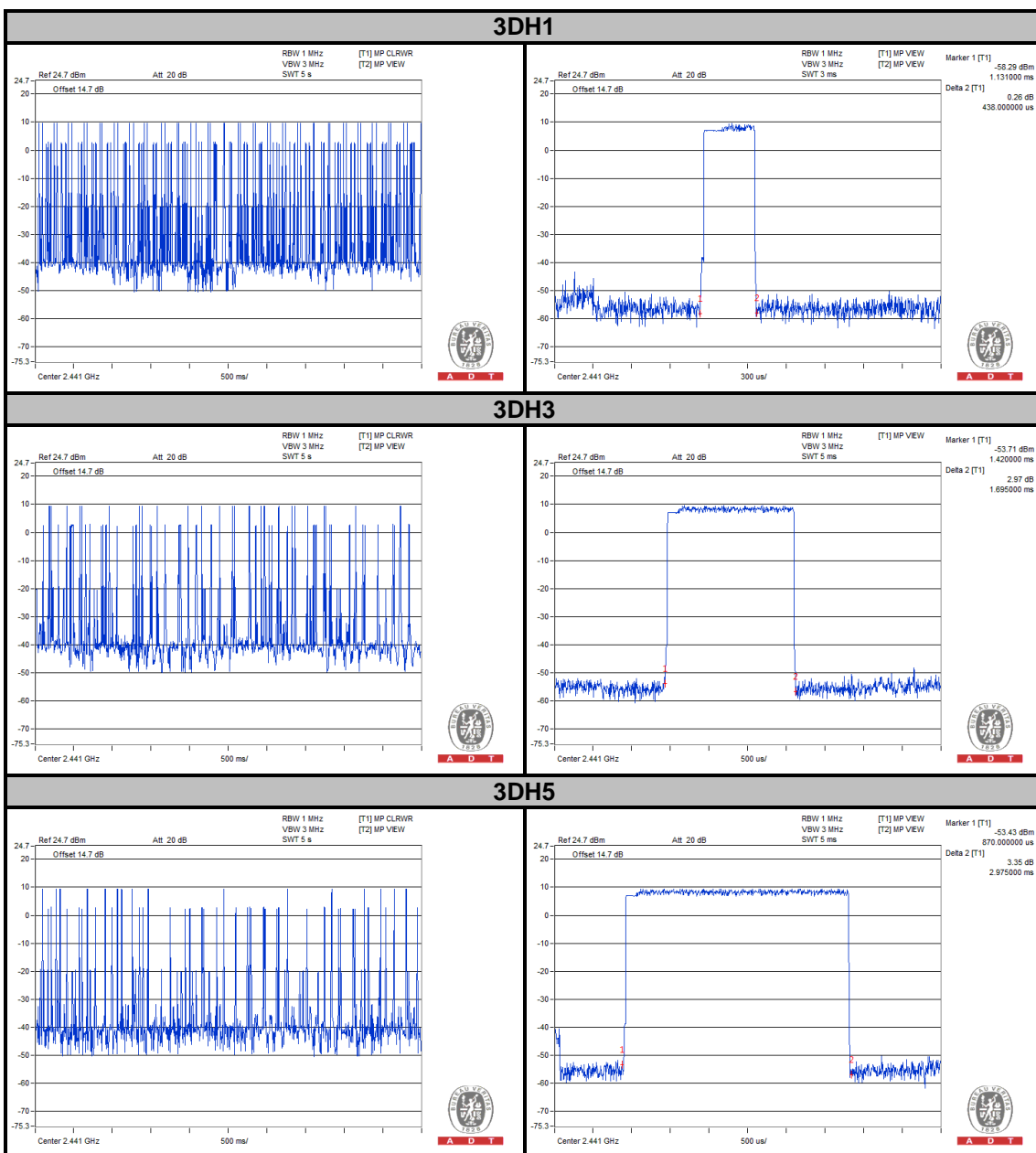

4.5 CHANNEL BANDWIDTH

4.5.1 LIMITS OF CHANNEL BANDWIDTH

For frequency hopping system operating in the 2400-2483.5MHz, If the 20dB bandwidth of hopping channel is greater than 25kHz, two-thirds 20dB bandwidth of hopping channel shall be a minimum limit for the hopping channel separation.

4.5.2 TEST SETUP

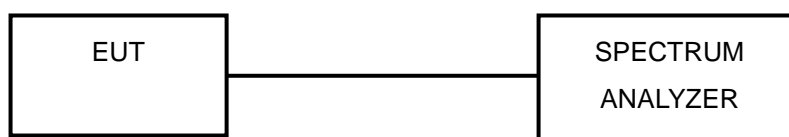

4.5.3 TEST INSTRUMENTS

Refer to section 4.1.2 to get information of above instrument.

4.5.4 TEST PROCEDURE

- a. Check the calibration of the measuring instrument using either an internal calibrator or a known signal from an external generator.
- b. Turn on the EUT and connect it to measurement instrument. Then set it to any one convenient frequency within its operating range. Set a reference level on the measuring instrument equal to the highest peak value.
- c. Measure the frequency difference of two frequencies that were attenuated 20dB from the reference level. Record the frequency difference as the emission bandwidth.
- d. Repeat above procedures until all frequencies measured were complete.

4.5.5 DEVIATION FROM TEST STANDARD

No deviation.

4.5.6 EUT OPERATING CONDITION

The software provided by client enabled the EUT to transmit and receive data at lowest, middle and highest channel frequencies individually.



A D T

4.5.7 TEST RESULTS

| CHANNEL | FREQUENCY (MHz) | 20dB BANDWIDTH (MHz) | | |
|---------|-----------------|----------------------|----------------|-------|
| | | GFSK | $\pi/4$ -DQPSK | 8DPSK |
| 0 | 2402 | 0.958 | 1.36 | 1.32 |
| 39 | 2441 | 0.958 | 1.35 | 1.32 |
| 78 | 2480 | 0.961 | 1.35 | 1.31 |

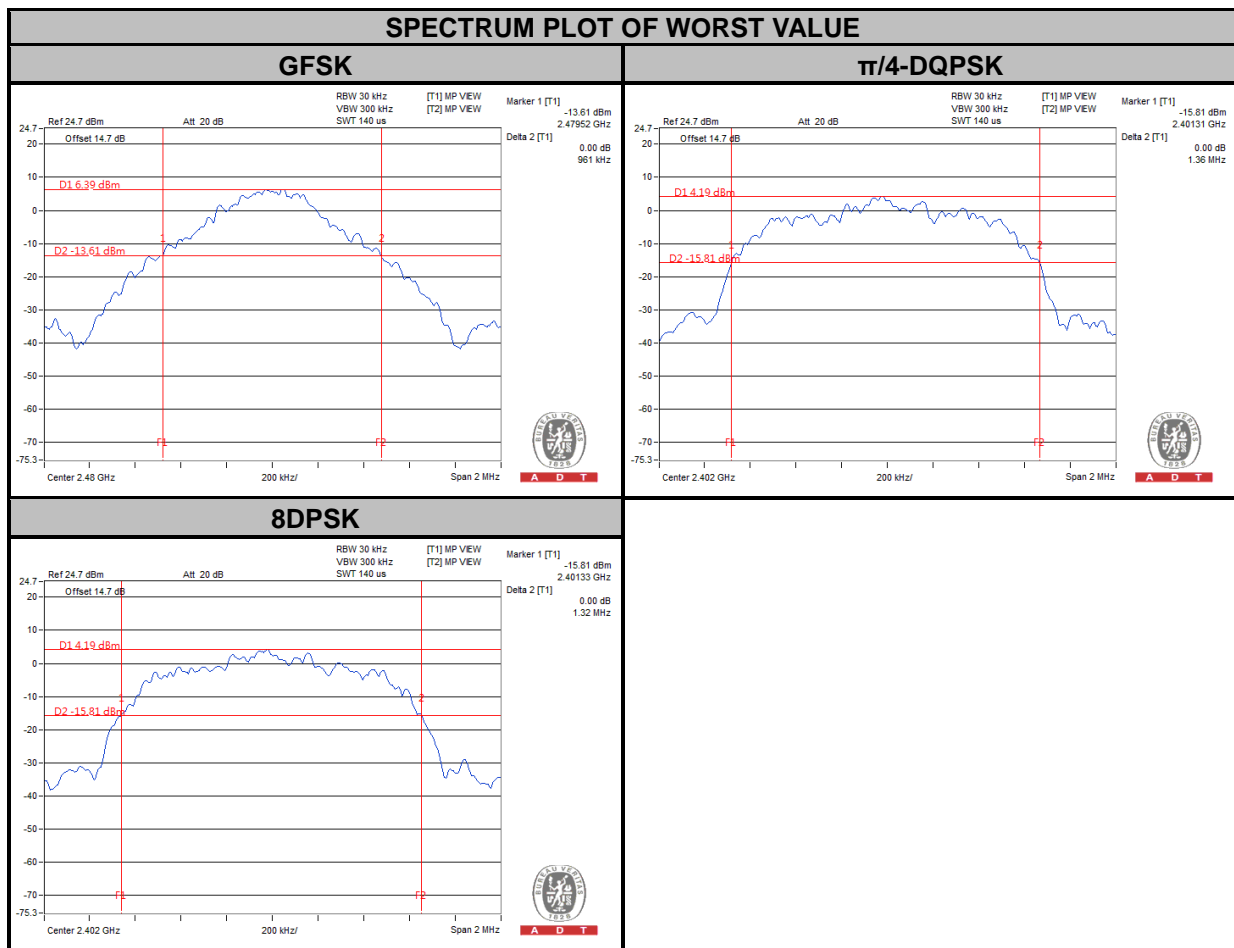

4.6 HOPPING CHANNEL SEPARATION

4.6.1 LIMITS OF HOPPING CHANNEL SEPARATION

At least 25kHz or two-third of 20dB hopping channel bandwidth (whichever is greater).

4.6.2 TEST SETUP

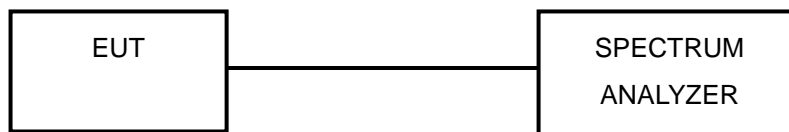

4.6.3 TEST INSTRUMENTS

Refer to section 4.1.2 to get information of above instrument.

4.6.4 TEST PROCEDURE

- a. Check the calibration of the measuring instrument using either an internal calibrator or a known signal from an external generator.
- b. Turn on the EUT and connect it to measurement instrument. Then set it to any one convenient frequency within its operating range.
- c. By using the MaxHold function record the separation of two adjacent channels.
- d. Measure the frequency difference of these two adjacent channels by SA MARK function. And then plot the result on SA screen.
- e. Repeat above procedures until all frequencies measured were complete.

4.6.5 DEVIATION FROM TEST STANDARD

No deviation.



A D T

4.6.6 TEST RESULTS

| CHAN. | FREQ. (MHz) | ADJACENT CHANNEL SEPARATION (MHz) | | | 20dB BANDWIDTH (MHz) | | | MINIMUM LIMIT (MHz) | | | PASS / FAIL |
|-------|-------------|-----------------------------------|----------------|-------|----------------------|----------------|-------|---------------------|----------------|-------|-------------|
| | | GFSK | $\pi/4$ -DQPSK | 8DPSK | GFSK | $\pi/4$ -DQPSK | 8DPSK | GFSK | $\pi/4$ -DQPSK | 8DPSK | |
| 0 | 2402 | 1.00 | 1.00 | 1.00 | 0.958 | 1.36 | 1.32 | 0.639 | 0.907 | 0.880 | PASS |
| 39 | 2441 | 1.00 | 1.00 | 1.00 | 0.958 | 1.35 | 1.32 | 0.639 | 0.900 | 0.880 | PASS |
| 78 | 2480 | 1.00 | 1.00 | 1.00 | 0.961 | 1.35 | 1.31 | 0.641 | 0.900 | 0.873 | PASS |

NOTE:

- The minimum limit is two-third 20dB bandwidth.

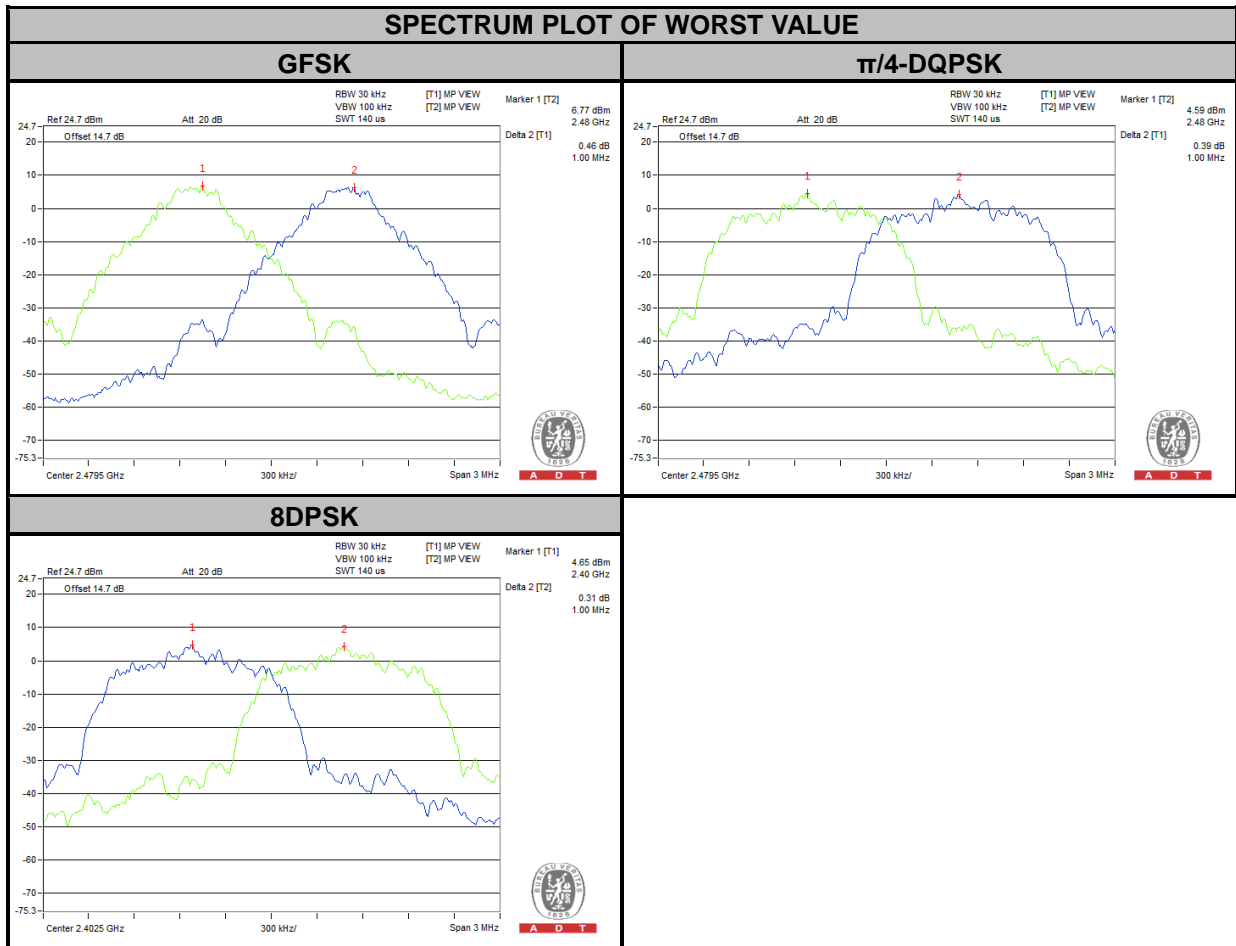

4.7 MAXIMUM OUTPUT POWER

4.7.1 LIMITS OF MAXIMUM OUTPUT POWER MEASUREMENT

The Maximum Output Power Measurement is 125mW.

4.7.2 TEST SETUP

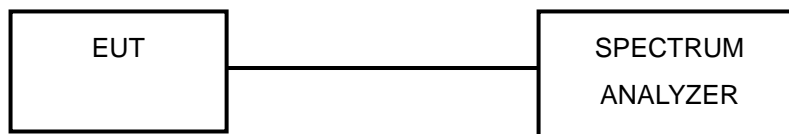

4.7.3 TEST INSTRUMENTS

Refer to section 4.1.2 to get information of above instrument.

4.7.4 TEST PROCEDURE

- Check the calibration of the measuring instrument using either an internal calibrator or a known signal from an external generator.
- Turn on the EUT and connect it to measurement instrument. Then set it to any one convenient frequency within its operating range. Set a reference level on the measuring instrument equal to the highest peak value.
- The center frequency of the spectrum analyzer is set to the fundamental frequency and using 3MHz RBW and 10 MHz VBW.
- Measure the captured power within the band and recording the plot.
- Repeat above procedures until all frequencies required were complete.

4.7.5 DEVIATION FROM TEST STANDARD

No deviation.

4.7.6 EUT OPERATING CONDITION

The software provided by client enabled the EUT to transmit and receive data at lowest, middle and highest channel frequencies individually.



A D T

4.7.7 TEST RESULTS

| CHANNEL | FREQUENCY (MHz) | OUTPUT POWER (mW) | | | OUTPUT POWER (dBm) | | | POWER LIMIT (mW) | PASS / FAIL |
|---------|-----------------|-------------------|----------------|---------------|--------------------|----------------|--------------|------------------|-------------|
| | | GFSK | $\pi/4$ -DQPSK | 8DPSK | GFSK | $\pi/4$ -DQPSK | 8DPSK | | |
| 0 | 2402 | 10.641 | 10.691 | 12.246 | 10.27 | 10.29 | 10.88 | 125 | PASS |
| 39 | 2441 | 10.520 | 10.568 | 12.274 | 10.22 | 10.24 | 10.89 | 125 | PASS |
| 78 | 2480 | 11.749 | 12.023 | 12.023 | 10.70 | 10.80 | 10.80 | 125 | PASS |

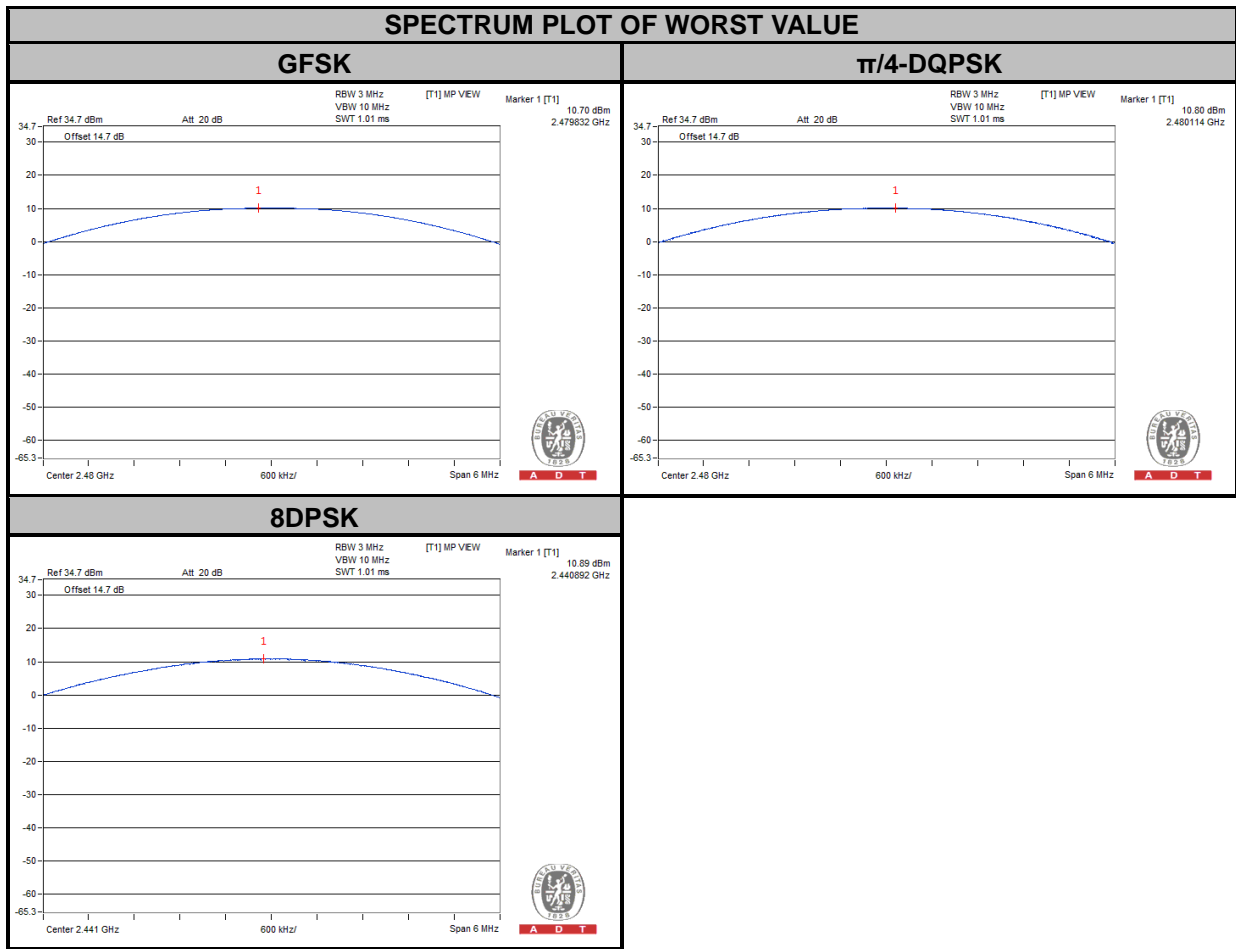



A D T

4.8 CONDUCTED OUT OF BAND EMISSION MEASUREMENT

4.8.1 LIMITS OF CONDUCTED OUT OF BAND EMISSION MEASUREMENT

Below -20dB of the highest emission level of operating band (in 100kHz RBW).

4.8.2 TEST INSTRUMENTS

Refer to section 4.1.2 to get information of above instrument.

4.8.3 TEST PROCEDURE

1. Set RBW = 100 kHz .
2. Set VBW = 300 kHz .
3. Set span to encompass the spectrum to be examined.
4. Detector = peak.
5. Trace Mode = max hold.
6. Sweep = auto couple.

4.8.4 DEVIATION FROM TEST STANDARD

No deviation.

4.8.5 EUT OPERATING CONDITION

The software provided by client enabled the EUT to transmit continuously.

4.8.6 TEST RESULTS

The spectrum plots are attached on the following images. D1 line indicates the highest level, D2 line indicates the 20dB offset below D1. It shows compliance with the requirement.



A D T

GFSK

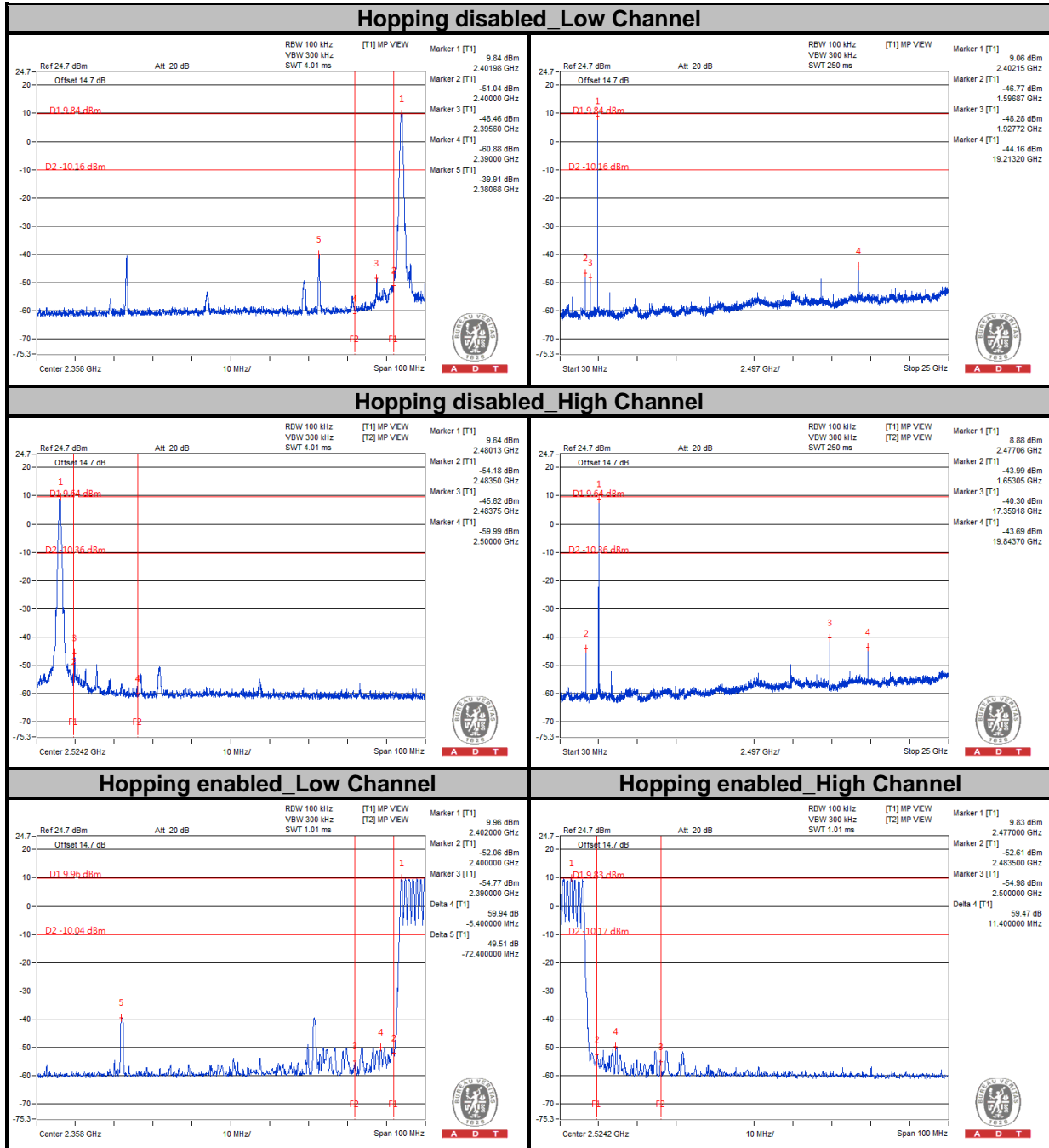



A D T

$\pi/4$ -DQPSK

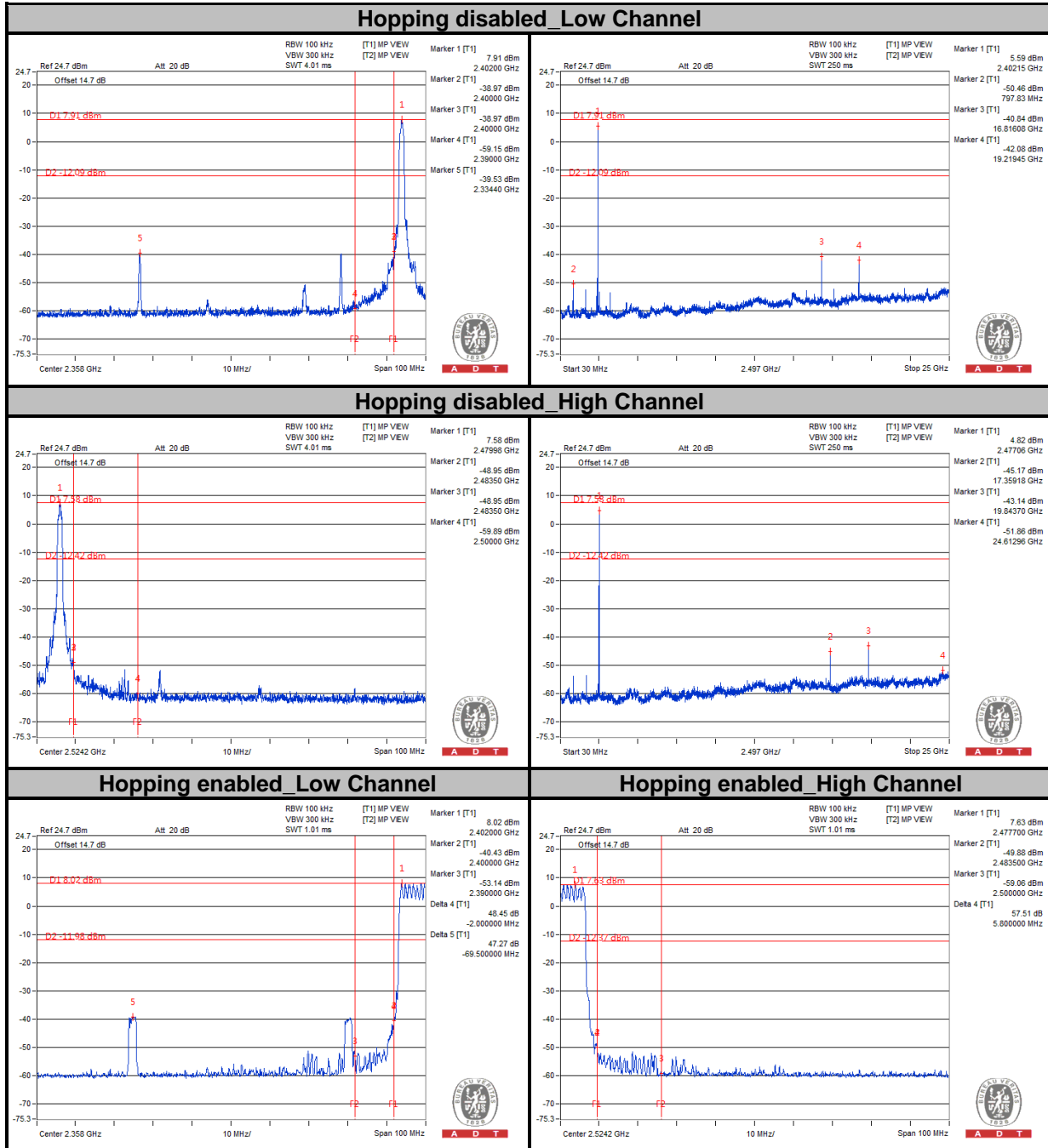



A D T

8DPSK

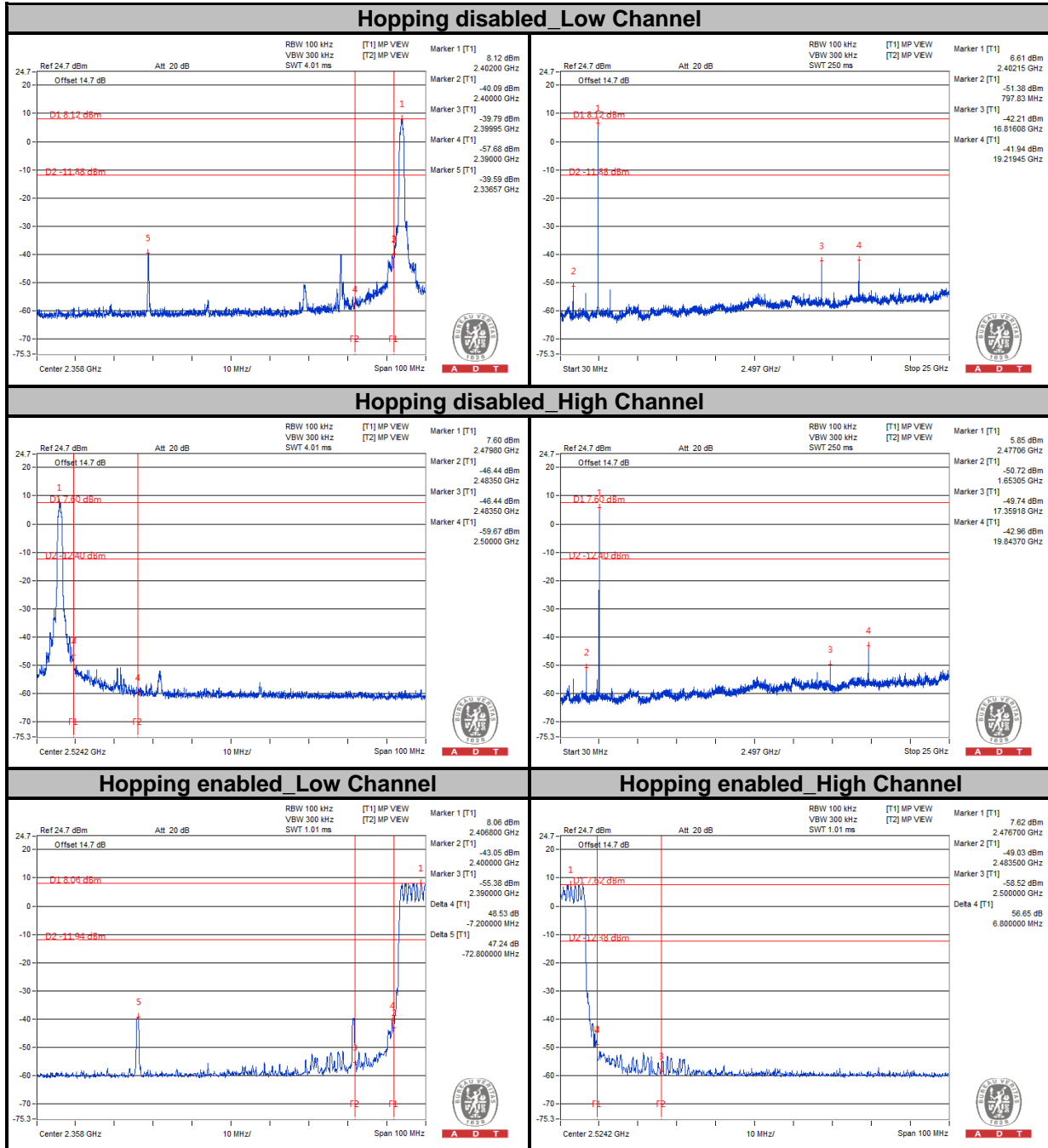



A D T

5. PHOTOGRAPHS OF THE TEST CONFIGURATION

Please refer to the attached file (Test Setup Photo).



6. INFORMATION ON THE TESTING LABORATORIES

We, Bureau Veritas Consumer Products Services (H.K.) Ltd., Taoyuan Branch, were founded in 1988 to provide our best service in EMC, Radio, Telecom and Safety consultation. Our laboratories are accredited and approved according to ISO/IEC 17025.

If you have any comments, please feel free to contact us at the following:

Linko EMC/RF Lab:

Tel: 886-2-26052180

Fax: 886-2-26051924

Hsin Chu EMC/RF/Telecom Lab:

Tel: 886-3-5935343

Fax: 886-3-5935342

Hwa Ya EMC/RF/Safety Lab:

Tel: 886-3-3183232

Fax: 886-3-3270892

Email: service.adt@tw.bureauveritas.com

Web Site: www.bureauveritas-adt.com

The address and road map of all our labs can be found in our web site also.



A D T

7. APPENDIX A – MODIFICATIONS RECORDERS FOR ENGINEERING CHANGES TO THE EUT BY THE LAB

No any modifications are made to the EUT by the lab during the test.

---END---