

FCC Test Report

Report No.: RFBDZB-WTW-P21020455

FCC ID: RFHPOCIW22C001

Test Model: POCi-W22C-ULT5

Received Date: 2021/2/20

Test Date: 2022/3/7 ~ 2022/3/10

Issued Date: 2022/6/13

Applicant: IEI Integration Corp.

Address: No. 29, Zhongxing RD., Xizhi Dist., New Taipei City 221, Taiwan (R.O.C.)

Issued By: Bureau Veritas Consumer Products Services (H.K.) Ltd., Taoyuan Branch
Lin Kou Laboratories

Lab Address: No. 47-2, 14th Ling, Chia Pau Vil., Lin Kou Dist., New Taipei City, Taiwan

**FCC Registration /
Designation Number:** 198487 / TW2021



This report is for your exclusive use. Any copying or replication of this report to or for any other person or entity, or use of our name or trademark, is permitted only with our prior written permission. This report sets forth our findings solely with respect to the test samples identified herein. The results set forth in this report are not indicative or representative of the quality or characteristics of the lot from which a test sample was taken or any similar or identical product unless specifically and expressly noted. Our report includes all of the tests requested by you and the results thereof based upon the information that you provided to us. You have 60 days from date of issuance of this report to notify us of any material error or omission caused by our negligence, provided, however, that such notice shall be in writing and shall specifically address the issue you wish to raise. A failure to raise such issue within the prescribed time shall constitute your unqualified acceptance of the completeness of this report, the tests conducted and the correctness of the report contents. Unless specific mention, the uncertainty of measurement has been explicitly taken into account to declare the compliance or non-compliance to the specification.

Table of Contents

Release Control Record	3
1 Certificate of Conformity	4
2 Summary of Test Results	5
2.1 Measurement Uncertainty	5
2.2 Modification Record	5
3 General Information	6
3.1 General Description of EUT	6
3.2 Description of Test Modes	6
3.2.1 Test Mode Applicability and Tested Channel Detail	7
3.3 Description of Support Units	8
3.3.1 Configuration Of System Under Test	9
3.4 General Description of Applied Standards	10
4 Test Types and Results	11
4.1 Radiated Emission and Bandedge Measurement	11
4.1.1 Limits of Radiated Emission and Bandedge Measurement	11
4.1.2 Test Instruments	12
4.1.3 Test Procedures	13
4.1.4 Deviation from Test Standard	13
4.1.5 Test Set Up	14
4.1.6 EUT Operating Conditions	14
4.1.7 Test Results	15
4.2 Conducted Emission Measurement	23
4.2.1 Limits of Conducted Emission Measurement	23
4.2.2 Test Instruments	23
4.2.3 Test Procedures	24
4.2.4 Deviation from Test Standard	24
4.2.5 Test Setup	24
4.2.6 EUT Operating Conditions	24
4.2.7 Test Results	25
4.3 Frequency Stability	27
4.3.1 Limits of Frequency Stability Measurement	27
4.3.2 Test Setup	27
4.3.3 Test Instruments	27
4.3.4 Test Procedure	27
4.3.5 Deviation from Test Standard	27
4.3.6 EUT Operating Conditions	27
4.3.7 Test Result	28
4.4 20dB Bandwidth	29
4.4.1 Limits Of 20dB Bandwidth Measurement	29
4.4.2 Test Setup	29
4.4.3 Test Instruments	29
4.4.4 Test Procedures	29
4.4.5 Deviation from Test Standard	29
4.4.6 EUT Operating Conditions	29
4.4.7 Test Results	30
5 Pictures of Test Arrangements	31
Appendix – Information of the Testing Laboratories	32

Release Control Record

Issue No.	Description	Date Issued
RFBZB-WTW-P21020455	Original release	2022/6/13

1 Certificate of Conformity

Product: MEDICAL PANEL PC

Brand: iEi

Test Model: POCi-W22C-ULT5

Sample Status: Engineering sample

Applicant: IEI Integration Corp.

Test Date: 2022/3/7 ~ 2022/3/10

Standards: 47 CFR FCC Part 15, Subpart C (Section 15.225)

47 CFR FCC Part 15, Subpart C (Section 15.215)

ANSI C63.10:2013

The above equipment has been tested by **Bureau Veritas Consumer Products Services (H.K.) Ltd., Taoyuan Branch**, and found compliance with the requirement of the above standards. The test record, data evaluation & Equipment Under Test (EUT) configurations represented herein are true and accurate accounts of the measurements of the sample's RF characteristics under the conditions specified in this report.

Prepared by :



Date:

2022/6/13

Jessica Cheng / Senior Specialist

Approved by :



Date:

2022/6/13

Jeremy Lin / Project Engineer

2 Summary of Test Results

47 CFR FCC Part 15, Subpart C (SECTION 15.225, 15.215)

FCC Clause	Test Item	Result	Remarks
15.207	Conducted emission test	Pass	Meet the requirement of limit. Minimum passing margin is -7.39dB at 0.62266MHz
15.225 (a)	The field strength of any emissions within the band 13.553-13.567 MHz	Pass	Meet the requirement of limit. Minimum passing margin is -87.12dB at 13.56MHz.
15.225 (b)	The field strength of any emissions within the bands 13.410-13.553 MHz and 13.567-13.710 MHz	Pass	Meet the requirement of limit.
15.225 (c)	The field strength of any emissions within the bands 13.110-13.410 MHz and 13.710-14.010 MHz	Pass	Meet the requirement of limit.
15.225 (d)	The field strength of any emissions appearing outside of the 13.110-14.010 MHz band	Pass	Meet the requirement of limit. Minimum passing margin is -4.36dB at 41.64MHz
15.225 (e)	The frequency tolerance	Pass	Meet the requirement of limit.
15.215 (c)	20dB Bandwidth	Pass	Meet the requirement of limit.

Note: Determining compliance based on the results of the compliance measurement, not taking into account measurement instrumentation uncertainty

2.1 Measurement Uncertainty

Where relevant, the following measurement uncertainty levels have been estimated for tests performed on the EUT as specified in CISPR 16-4-2:

Measurement	Frequency	Expanded Uncertainty (k=2) (\pm)
Conducted Emissions at mains ports	150kHz ~ 30MHz	3.00 dB
Radiated Emissions up to 1 GHz	9kHz ~ 30MHz	2.38 dB
	30MHz ~ 1GHz	5.70 dB

2.2 Modification Record

There were no modifications required for compliance.

3 General Information

3.1 General Description of EUT

Product	MEDICAL PANEL PC
Brand	iEi
Test Model	POCi-W22C-ULT5
Sample Status	Engineering sample
Power Supply Rating	19Vdc from adapter
Modulation Type	ASK
Operating Frequency	13.56MHz
Antenna Type	PIFA antenna
Field Strength	-3.12dBuV/m @30m
Accessory Device	N/A
Data Cable Supplied	N/A

Note:

1. The EUT contains WiFi module as below:

Contains WIFI Module
FCC ID: PD9AX200NG

2. The emission of the simultaneous operation (WLAN & RFID) has been evaluated and no non-compliance was found.

3. EUT uses following Open Frame Power.

Item	Adapter
Brand	FSP
Model	FSP150M-ABA
Input Power	90~264Vac
Output Power	19Vdc
Power Cord	Non-shielded AC 3-Pin cable (1.8m) Non-shielded DC cable (1.2m) with two ferrite cores

4. The EUT was pre-tested with the following modes:

- ✧ Operating Mode (with NFC card)
- ✧ Standby Mode (without NFC card)

The worst emission level was found when the EUT tested under **Operating Mode (with NFC card)** therefore, only its test data was recorded in this report.

5. The above Antenna information is declared by manufacturer and for more detailed features description, please refer to the manufacturer's specifications, the laboratory shall not be held responsible.
6. The above EUT information is declared by manufacturer and for more detailed features description, please refer to the manufacturer's specifications or user's manual.

3.2 Description of Test Modes

1 channel is provided to EUT:

Channel	Frequency (MHz)
1	13.56

3.2.1 Test Mode Applicability and Tested Channel Detail

EUT Configure Mode	Applicable To				Description
	RE<1G	PLC	FS	EB	
-	√	√	√	√	-

Where **RE<1G**: Radiated Emission below 1GHz
PLC: Power Line Conducted Emission

FS: Frequency Stability
EB: 20dB Bandwidth measurement

Radiated Emission Test (Below 1GHz):

- Pre-Scan has been conducted to determine the worst-case mode from all possible combinations between available modulations, data rates and antenna ports (if EUT with antenna diversity architecture).
- Following channel(s) was (were) selected for the final test as listed below.

EUT Configure Mode	Available Channel	Frequency (MHz)	Modulation Type
-	1	13.56	ASK

Power Line Conducted Emission Test:

- Pre-Scan has been conducted to determine the worst-case mode from all possible combinations between available modulations, data rates and antenna ports (if EUT with antenna diversity architecture).
- Following channel(s) was (were) selected for the final test as listed below.

EUT Configure Mode	Operating Frequency (kHz)	Tested Frequency (kHz)	Modulation Type
-	1	13.56	ASK

Frequency Stability:

- This item includes all test value of each mode, but only includes spectrum plot of worst value of each mode.
- Pre-Scan has been conducted to determine the worst-case mode from all possible combinations between available modulations, data rates and antenna ports (if EUT with antenna diversity architecture).
- Following channel(s) was (were) selected for the final test as listed below.

EUT Configure Mode	Operating Frequency (kHz)	Tested Frequency (kHz)	Modulation Type
-	1	13.56	ASK

20dB Bandwidth:

- This item includes all test value of each mode, but only includes spectrum plot of worst value of each mode.
- Pre-Scan has been conducted to determine the worst-case mode from all possible combinations between available modulations, data rates and antenna ports (if EUT with antenna diversity architecture).
- Following channel(s) was (were) selected for the final test as listed below.

EUT Configure Mode	Operating Frequency (kHz)	Tested Frequency (kHz)	Modulation Type
-	1	13.56	ASK

Test Condition:

Applicable To	Environmental Conditions	Input Power	Tested by
RE<1G	25 deg. C, 53% RH, 19 deg. C, 70% RH	120Vac, 60Hz	Ian Chang
PLC	25 deg. C, 75% RH	120Vac, 60Hz	Ian Chang
FS	25 deg. C, 76% RH	120Vac, 60Hz	Dalen Dai
EB	25 deg. C, 76% RH	120Vac, 60Hz	Dalen Dai

3.3 Description of Support Units

The EUT has been tested as an independent unit together with other necessary accessories or support units. The following support units or accessories were used to form a representative test configuration during the tests.

ID	Product	Brand	Model No.	Serial No./lot no.	FCC ID	Remarks
A.	NFC Card	NA	NA	NA	NA	Provided by Lab
B.	LCD Monitor	Dell	S2817Q	CN-0GD45P-74445-724-116M	NA	Provided by Lab
C.	USB 3.0 Hard Disk	WD	WDBUZG0010BB K-PESN	WX61A45JRXL	NA	Provided by Lab
D.	USB 3.0 Hard Disk	WD	WDBUZG0010BB K-PESN	WXN1E84F21W	NA	Provided by Lab
E.	USB 3.0 Hard Disk	WD	WDBUZG0010BB K-PESN	WXF1E15ED8MF	NA	Provided by Lab
F.	USB 3.0 Hard Disk	WD	WDBUZG0010BB K-PESN	WX91E942NS1Z	NA	Provided by Lab
G.	MODEM	ACEEX	1414	980020505	NA	Provided by Lab
H.	USB Mouse	Microsoft	1113	9.17052E+12	NA	Provided by Lab
I.	USB KEYBOARD	BTC	5200U	G09302046354	NA	Provided by Lab
J.	Notebook PC	Lenove	81LG	PHNGBDP	NA	Provided by Lab
K.	Notebook PC	Lenove	81LG	PF1NF9V2	NA	Provided by Lab

ID	Cable Descriptions	Qty.	Length (m)	Shielding (Yes/ No)	Cores (Qty.)	Remarks
1.	RJ45 Cable	1	10	N	0	Provided by Lab
2.	RJ45 Cable	1	10	N	0	Provided by Lab
3.	HDMI Cable	1	1.8	Y	0	Provided by Lab
4.	USB Cable*4	1	1.0	Y	0	Provided by Lab
5.	RS232 Cable	1	1.2	Y	0	Provided by Lab
6.	Audio Cable	1	1.2	N	0	Provided by Lab
7.	USB Cable	1	1.8	Y	0	Provided by Lab
8.	USB Cable	1	1.8	Y	0	Provided by Lab
9.	DC Cable	1	1.2	N	2	Supplied by applicant
10.	AC Power Cable	1	1.8	N	0	Supplied by applicant

3.3.1 Configuration Of System Under Test

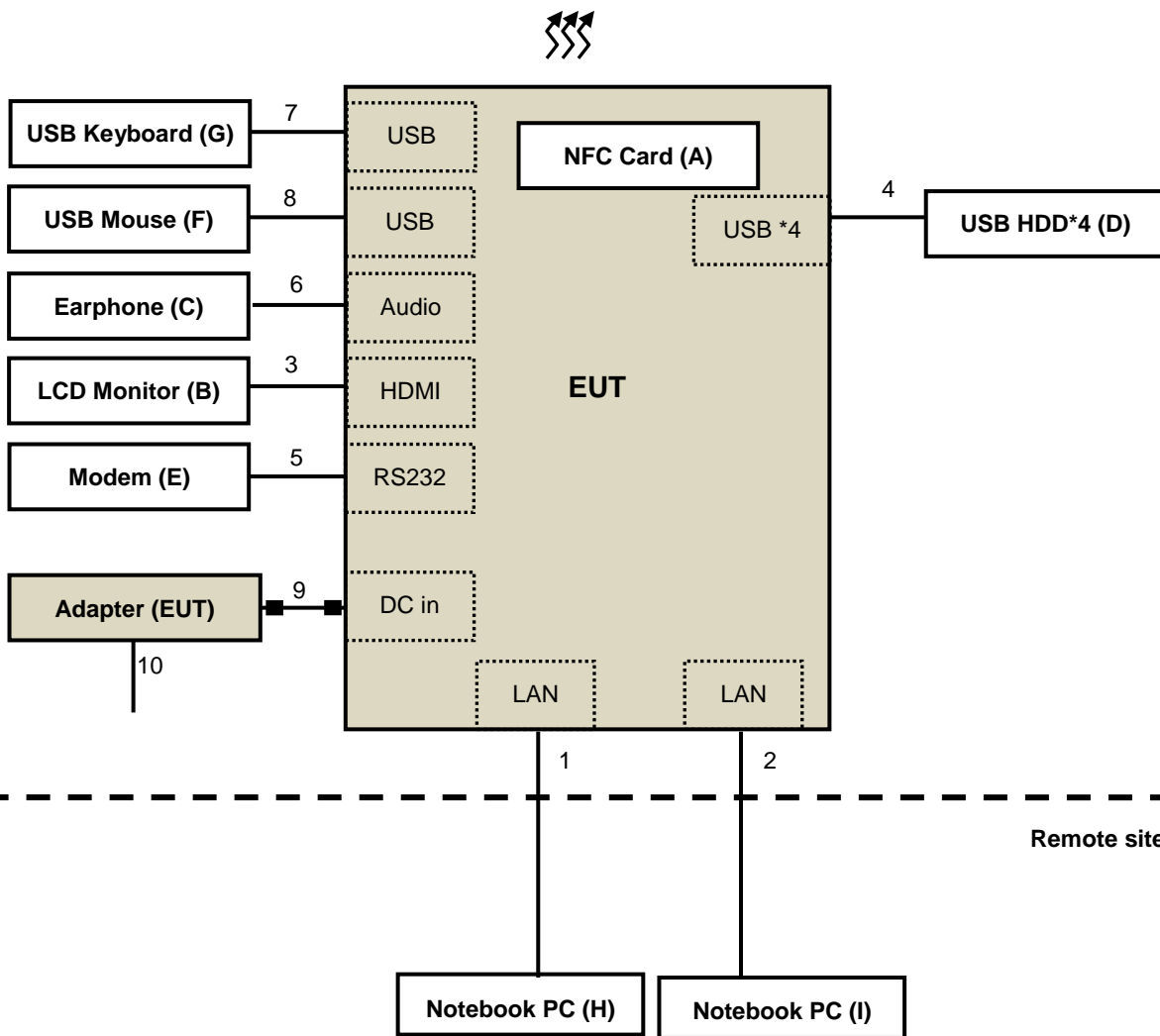

3.4 General Description of Applied Standards

The EUT is a RF Product. According to the specifications of the manufacturer, it must comply with the requirements of the following standards:

FCC Part 15, Subpart C (15.225)

FCC Part 15, Subpart C (15.215)

ANSI C63.10-2013

All test items have been performed and recorded as per the above standards.

4 Test Types and Results

4.1 Radiated Emission and Bandedge Measurement

4.1.1 Limits of Radiated Emission and Bandedge Measurement

The field strength of any emissions within the band 13.553-13.567 MHz shall not exceed 15,848 microvolts/meter at 30 meters.

Within the bands 13.410-13.553 MHz and 13.567-13.710 MHz, the field strength of any emissions shall not exceed 334 microvolts/meter at 30 meters.

Within the bands 13.110-13.410 MHz and 13.710-14.010 MHz the field strength of any emissions shall not exceed 106 microvolts/meter at 30 meters.

The field strength of any emissions appearing outside of the 13.110-14.010 MHz band shall not exceed the general radiated emission limits in §15.209.

Frequencies (MHz)	Field Strength (microvolts/meter)	Measurement Distance (meters)
0.009 ~ 0.490	2400/F(kHz)	300
0.490 ~ 1.705	24000/F(kHz)	30
1.705 ~ 30.0	30	30
30 ~ 88	100	3
88 ~ 216	150	3
216 ~ 960	200	3
Above 960	500	3

NOTE:

1. The lower limit shall apply at the transition frequencies.
2. Emission level (dBuV/m) = 20 log Emission level (uV/m).
3. For frequencies above 1000MHz, the field strength limits are based on average detector, however, the peak field strength of any emission shall not exceed the maximum permitted average limits, specified above by more than 20dB under any condition of modulation.

4.1.2 Test Instruments

Description & Manufacturer	Model no.	Serial No.	Calibrated Date	Calibrated Until
Spectrum Analyzer KEYSIGHT	N9030A	MY54490260	2021/7/23	2022/7/22
Spectrum Analyzer R&S	FSV40	101042	2021/9/9	2022/9/8
Software BVADT	ADT_Radiated_V8.7.0 8	NA	NA	NA
Software BVADT	ADT_RF Test Software V6.6.5.4	NA	NA	NA
Auto Control System(Antenna Tower, Table, Controller) ADT	SC100+AT100+TT100	NA	NA	NA
Pre_Amplifier EMCI	EMC001340	980269	2021/6/29	2022/6/28
LOOP ANTENNA EMCI	LPA600	270	2021/9/2	2023/9/1
RF Coaxial Cable Pacific	8D-FB	Cable-CH6-02	2021/7/13	2022/7/12
Pre_Amplifier Agilent	8447D	2944A10505	2022/2/17	2023/2/16
Bi-log Broadband Antenna Schwarzbeck	VULB9168	139	2021/11/1	2022/10/31
Bi-log Broadband Antenna Schwarzbeck	VULB9168	139	2021/11/1	2022/10/31
Antenna (Large Biconical) Schwarzbeck	VHBA 9123	480	2021/6/17	2022/6/16
RF Coaxial Cable TIMES	LMR-600	Cable-RF1-01	2021/3/11	2022/3/10
Spectrum Analyzer R&S	FSV40	101042	2021/9/9	2022/9/8
Temperature & Humidity Chamber TERCHY	MHU-225AU	920409	2021/7/2	2022/7/1
AC POWER SOURCE Schaffner	Proflin2105-208NSG1 007	55616	2021/6/2	2022/6/1

- NOTE:**
1. The calibration interval of the above test instruments is 12/24 months. And the calibrations are traceable to NML/ROC and NIST/USA.
 2. The test was performed in Chamber No. 6.
 3. Tested Date: 2022/3/7 ~ 2022/3/10

4.1.3 Test Procedures

For Radiated emission below 30MHz

- a. The EUT was placed on the top of a rotating table 0.8 meters above the ground at a 3 meter chamber room. The table was rotated 360 degrees to determine the position of the highest radiation.
- b. The EUT was set 3 meters away from the interference-receiving antenna, which was mounted on the top of a variable-height antenna tower.
- c. Parallel, perpendicular, and ground-parallel orientations of the antenna are set to make the measurement.
- d. For each suspected emission, the EUT was arranged to its worst case and the rotatable table was turned from 0 degrees to 360 degrees to find the maximum reading.
- e. The test-receiver system was set to Quasi-Peak Detect Function and Specified Bandwidth with Maximum Hold Mode, except for the frequency band (9kHz-90kHz, 110kHz-490kHz) set to average detect function and peak detect function.

Note:

1. The resolution bandwidth and video bandwidth of test receiver/spectrum analyzer is 200Hz at frequency band (9kHz-150kHz) and 9kHz at frequency below 30MHz (except 9kHz-150kHz).
2. There is a comparison data of both open-field test site and semi-Anechoic chamber, and the result came out very similar.

For Radiated emission above 30MHz

- a. The EUT was placed on the top of a rotating table 0.8 meters (for below 1GHz) above the ground at 3 meter chamber room for test. The table was rotated 360 degrees to determine the position of the highest radiation.
- b. The EUT was set 3 meters away from the interference-receiving antenna, which was mounted on the top of a variable-height antenna tower.
- c. The height of antenna is varied from one meter to four meters above the ground to determine the maximum value of the field strength. Both horizontal and vertical polarizations of the antenna are set to make the measurement.
- d. For each suspected emission, the EUT was arranged to its worst case and then the antenna was tuned to heights from 1 meter to 4 meters and the rotatable table was turned from 0 degrees to 360 degrees to find the maximum reading.
- e. The test-receiver system was set to quasi-peak detect function and specified bandwidth with maximum hold mode when the test frequency is below 1 GHz.

Note:

1. The resolution bandwidth and video bandwidth of test receiver/spectrum analyzer is 120kHz for Quasi-peak detection (QP) at frequency below 1GHz.
2. All modes of operation were investigated and the worst-case emissions are reported.

4.1.4 Deviation from Test Standard

No deviation.

4.1.5 Test Set Up

For Radiated emission below 30MHz

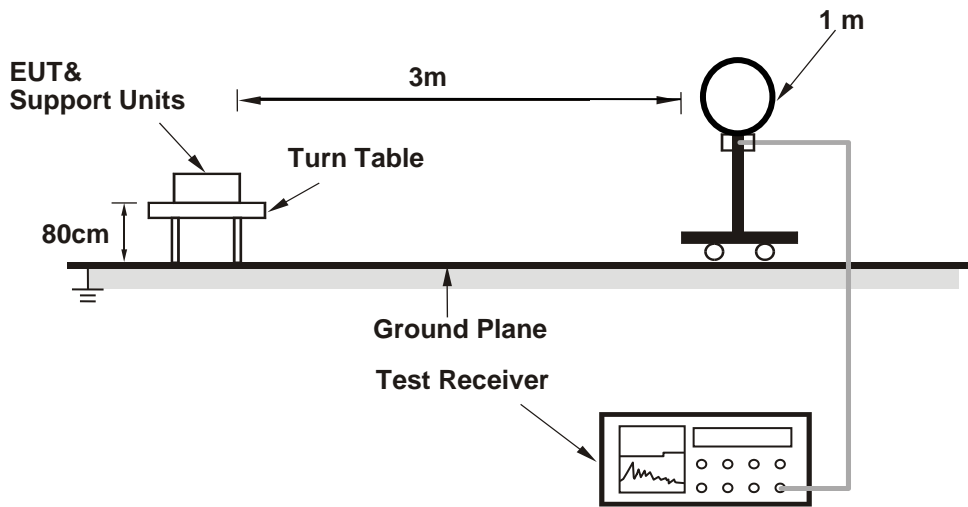

For Radiated emission 30MHz to 1GHz

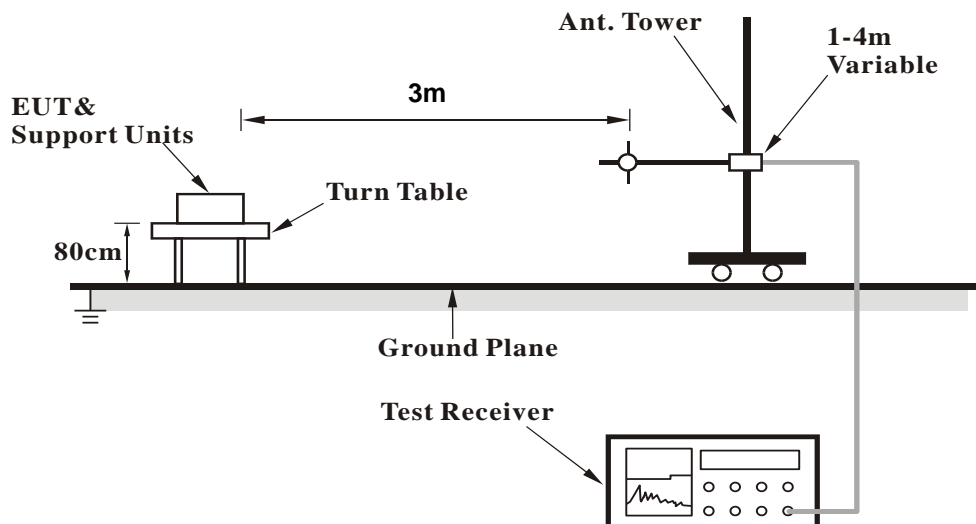

For the actual test configuration, please refer to the attached file (Test Setup Photo).

KDB 414788 OFS and Chamber Correlation Justification

- Based on FCC 15.31 (f) (2): measurements may be performed at a distance closer than that specified in regulations; however, an attempt should be made to avoid making measurements in the near field.
- Open-field site and chamber correlation testing had been performed and chamber measured test result is the worst case test result.

4.1.6 EUT Operating Conditions

- a. Connected the EUT to Adapter.
- b. Put the NFC card on the EUT.
- c. Set the EUT under transmission condition continuously at specific channel frequency.

4.1.7 Test Results

Test Frequency	13.56MHz	Detector Function	Quasi-Peak (QP)
Frequency Range	13.553 ~ 13.567MHz		

Antenna Polarity : Parallel								
No	Freq. (MHz)	Emission Level (dBuV/m) (30m)	Limit (dBuV/m)	Margin (dB)	Antenna Height (m)	Table Angle (Degree)	Raw Value (dBuV) (3m)	Correction Factor (dB/m)
1	*13.56	-3.12 QP	84.00	-87.12	1.00	276	34.90	-38.02

Remarks:

1. Emission Level(dBuV/m) = Raw Value(dBuV) + Correction Factor(dB/m)
2. Correction Factor(dB/m) = Antenna Factor(dB/m) + Cable Factor(dB) – Pre-Amplifier Factor(dB)+Distance Factor
3. Margin value = Emission Level – Limit value
4. The other emission levels were very low against the limit.
5. “ * “ : Fundamental frequency
6. Above limits have been translated by the formula

The measured field strength was extrapolated to distance 30 meters, using the formula that the limit of field strength varies as the inverse distance square (40dB per decade of distance)

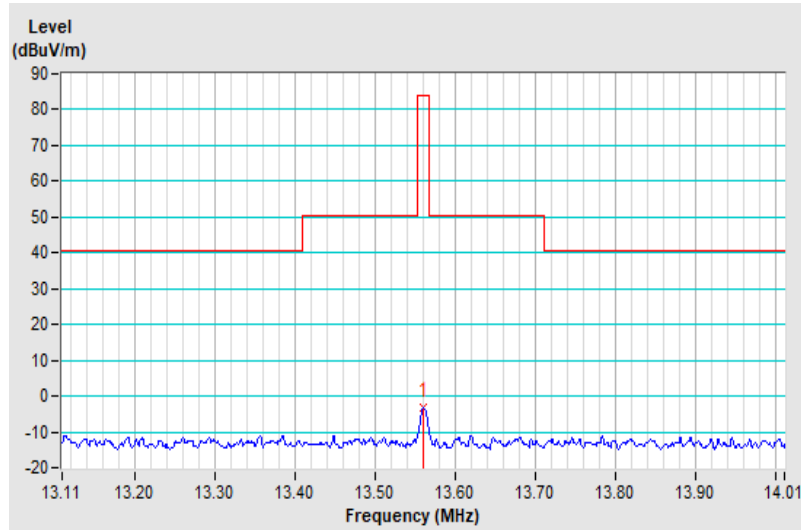

Test Frequency	13.56MHz	Detector Function	Quasi-Peak (QP)
Frequency Range	13.553 ~ 13.567MHz		

Antenna Polarity : Perpendicular								
No	Freq. (MHz)	Emission Level (dBuV/m) (30m)	Limit (dBuV/m)	Margin (dB)	Antenna Height (m)	Table Angle (Degree)	Raw Value (dBuV) (3m)	Correction Factor (dB/m)
1	*13.56	-8.75 QP	84.00	-92.75	1.00	146	29.27	-38.02

Remarks:

1. Emission Level(dBuV/m) = Raw Value(dBuV) + Correction Factor(dB/m)
2. Correction Factor(dB/m) = Antenna Factor(dB/m) + Cable Factor(dB) – Pre-Amplifier Factor(dB)+Distance Factor
3. Margin value = Emission Level – Limit value
4. The other emission levels were very low against the limit.
5. “ * “ : Fundamental frequency
6. Above limits have been translated by the formula

The measured field strength was extrapolated to distance 30 meters, using the formula that the limit of field strength varies as the inverse distance square (40dB per decade of distance)

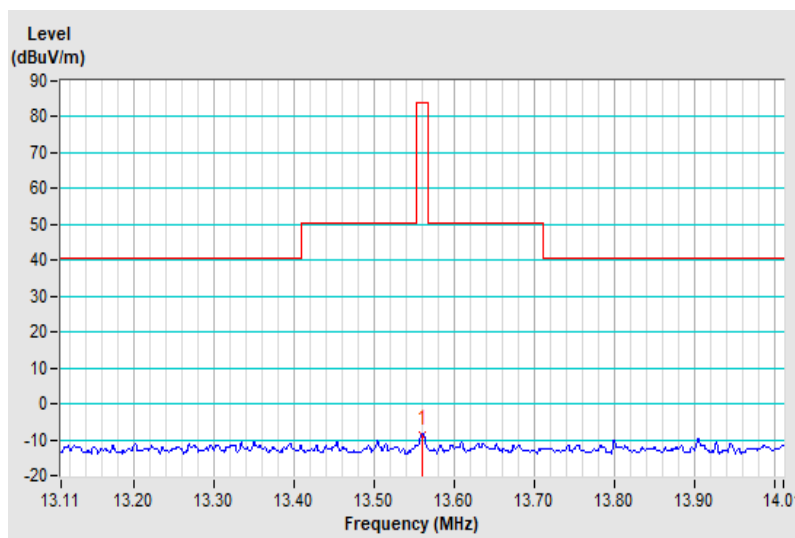

Test Frequency	13.56MHz	Detector Function	Quasi-Peak (QP)
Frequency Range	13.553 ~ 13.567MHz		

Antenna Polarity : Ground-parallel								
No	Freq. (MHz)	Emission Level (dBuV/m) (30m)	Limit (dBuV/m)	Margin (dB)	Antenna Height (m)	Table Angle (Degree)	Raw Value (dBuV) (3m)	Correction Factor (dB/m)
1	*13.56	-5.48 QP	84.00	-89.48	1.00	134	32.54	-38.02

Remarks:

1. Emission Level(dBuV/m) = Raw Value(dBuV) + Correction Factor(dB/m)
2. Correction Factor(dB/m) = Antenna Factor(dB/m) + Cable Factor(dB) – Pre-Amplifier Factor(dB)+Distance Factor
3. Margin value = Emission Level – Limit value
4. The other emission levels were very low against the limit.
5. “ * ” : Fundamental frequency
6. Above limits have been translated by the formula

The measured field strength was extrapolated to distance 30 meters, using the formula that the limit of field strength varies as the inverse distance square (40dB per decade of distance)

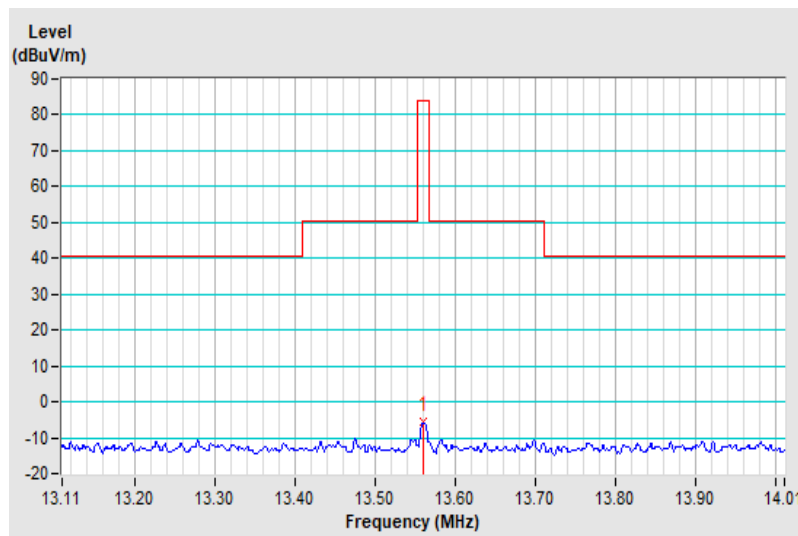

Test Frequency	13.56MHz	Detector Function	Quasi-Peak (QP)
Frequency Range	Below 30MHz		

Antenna Polarity : Parallel								
No	Freq. (MHz)	Emission Level (dBuV/m) (30m)	Limit (dBuV/m)	Margin (dB)	Antenna Height (m)	Table Angle (Degree)	Raw Value (dBuV) (3m)	Correction Factor (dB/m)
1	27.12	-17.27 QP	29.54	-46.81	1.00	224	19.12	-36.39

Remarks:

1. Emission Level(dBuV/m) = Raw Value(dBuV) + Correction Factor(dB/m)
2. Correction Factor(dB/m) = Antenna Factor(dB/m) + Cable Factor(dB) – Pre-Amplifier Factor(dB) +Distance Factor
3. Margin value = Emission Level – Limit value
4. The other emission levels were very low against the limit.
5. The measured field strength was extrapolated to distance 30 meters, using the formula that the limit of field strength varies as the inverse distance square (40dB per decade of distance)

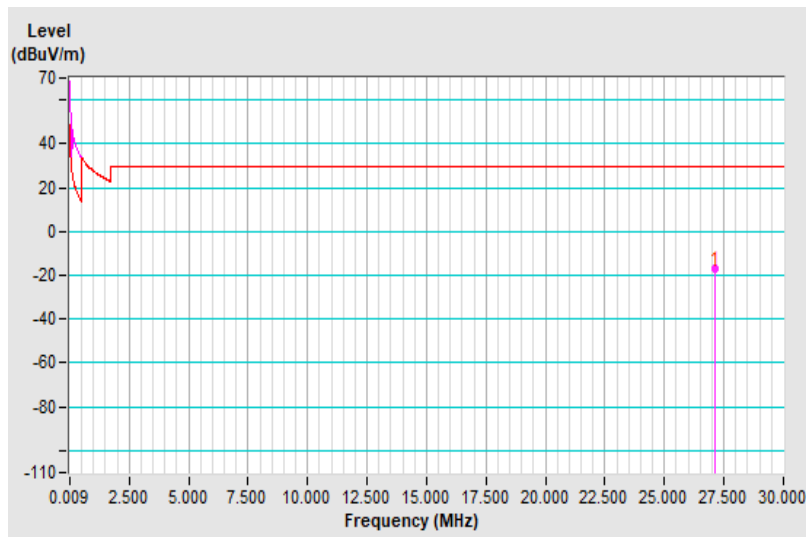

Test Frequency	13.56MHz	Detector Function	Quasi-Peak (QP)
Frequency Range	Below 30MHz		

Antenna Polarity : Perpendicular								
No	Freq. (MHz)	Emission Level (dBuV/m) (30m)	Limit (dBuV/m)	Margin (dB)	Antenna Height (m)	Table Angle (Degree)	Raw Value (dBuV) (3m)	Correction Factor (dB/m)
1	27.12	-21.03 QP	29.54	-50.57	1.00	239	15.36	-36.39

Remarks:

1. Emission Level(dBuV/m) = Raw Value(dBuV) + Correction Factor(dB/m)
2. Correction Factor(dB/m) = Antenna Factor(dB/m) + Cable Factor(dB) – Pre-Amplifier Factor(dB) +Distance Factor
3. Margin value = Emission Level – Limit value
4. The other emission levels were very low against the limit.
5. The measured field strength was extrapolated to distance 30 meters, using the formula that the limit of field strength varies as the inverse distance square (40dB per decade of distance)

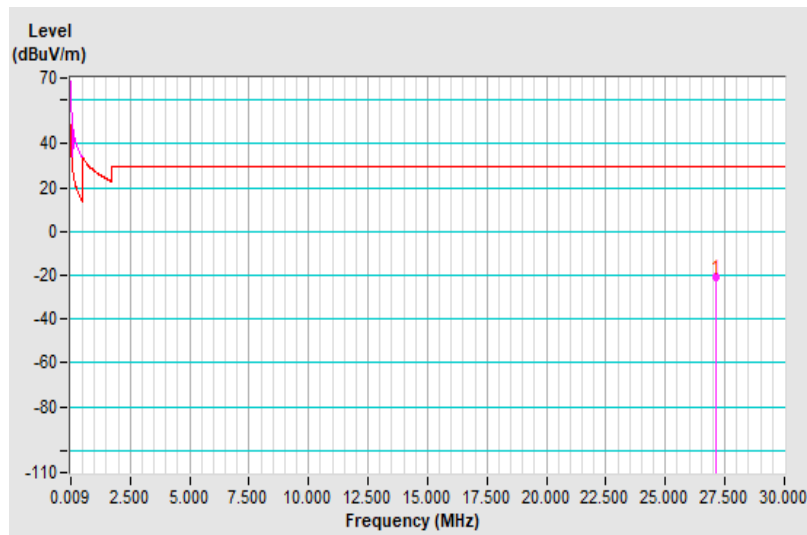

Test Frequency	13.56MHz	Detector Function	Quasi-Peak (QP)
Frequency Range	Below 30MHz		

Antenna Polarity : Ground-parallel								
No	Freq. (MHz)	Emission Level (dBuV/m) (30m)	Limit (dBuV/m)	Margin (dB)	Antenna Height (m)	Table Angle (Degree)	Raw Value (dBuV) (3m)	Correction Factor (dB/m)
1	27.12	-19.63 QP	29.54	-49.17	1.00	251	16.76	-36.39

Remarks:

1. Emission Level(dBuV/m) = Raw Value(dBuV) + Correction Factor(dB/m)
2. Correction Factor(dB/m) = Antenna Factor(dB/m) + Cable Factor(dB) – Pre-Amplifier Factor(dB) +Distance Factor
3. Margin value = Emission Level – Limit value
4. The other emission levels were very low against the limit.
5. The measured field strength was extrapolated to distance 30 meters, using the formula that the limit of field strength varies as the inverse distance square (40dB per decade of distance)

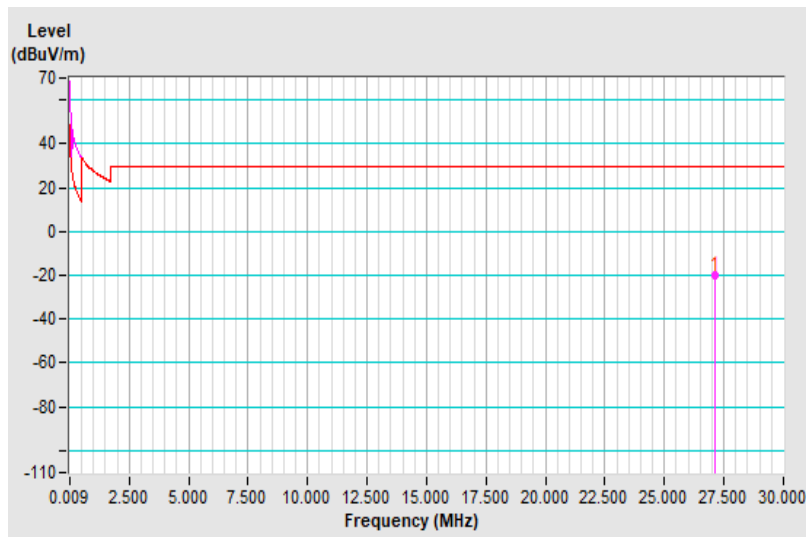

30MHz ~ 1GHz Data:

Test Frequency	13.56MHz	Detector Function	Quasi-Peak (QP)
Frequency Range	30MHz ~ 1GHz		

Antenna Polarity & Test Distance : Horizontal at 3 m								
No	Frequency (MHz)	Emission Level (dBuV/m)	Limit (dBuV/m)	Margin (dB)	Antenna Height (m)	Table Angle (Degree)	Raw Value (dBuV)	Correction Factor (dB/m)
1	41.64	27.52 QP	40.00	-12.48	3.97 H	293	36.52	-9.00
2	219.15	33.81 QP	46.00	-12.19	3.52 H	247	43.82	-10.01
3	415.09	34.73 QP	46.00	-11.27	2.70 H	166	37.94	-3.21
4	439.34	37.70 QP	46.00	-8.30	2.47 H	142	40.03	-2.33
5	622.67	32.59 QP	46.00	-13.41	2.05 H	101	31.05	1.54
6	752.65	36.24 QP	46.00	-9.76	1.75 H	71	32.37	3.87

Remarks:

1. Emission Level(dBuV/m) = Raw Value(dBuV) + Correction Factor(dB/m)
2. Correction Factor(dB/m) = Antenna Factor(dB/m) + Cable Factor(dB) – Pre-Amplifier Factor(dB)
3. Margin value = Emission Level – Limit value
4. The other emission levels were very low against the limit of frequency range 30MHz~1000MHz.

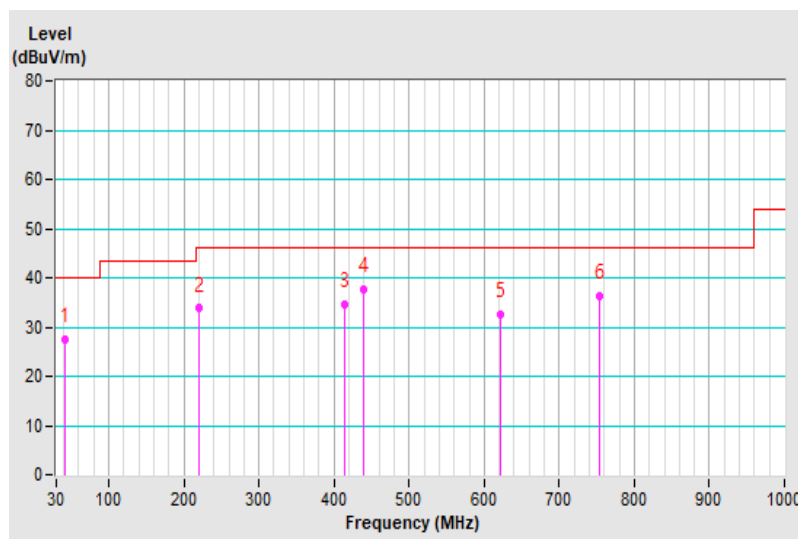

Test Frequency	13.56MHz	Detector Function	Quasi-Peak (QP)
Frequency Range	30MHz ~ 1GHz		

Antenna Polarity & Test Distance : Vertical at 3 m								
No	Frequency (MHz)	Emission Level (dBuV/m)	Limit (dBuV/m)	Margin (dB)	Antenna Height (m)	Table Angle (Degree)	Raw Value (dBuV)	Correction Factor (dB/m)
1	41.64	35.64 QP	40.00	-4.36	3.10 V	292	44.64	-9.00
2	207.51	27.56 QP	43.50	-15.94	2.56 V	238	37.83	-10.27
3	415.09	41.02 QP	46.00	-4.98	3.46 V	327	44.23	-3.21
4	622.67	33.61 QP	46.00	-12.39	2.26 V	208	32.07	1.54
5	740.04	34.37 QP	46.00	-11.63	2.04 V	187	30.97	3.40
6	829.28	35.79 QP	46.00	-10.21	1.71 V	155	30.19	5.60

Remarks:

1. Emission Level(dBuV/m) = Raw Value(dBuV) + Correction Factor(dB/m)
2. Correction Factor(dB/m) = Antenna Factor(dB/m) + Cable Factor(dB) – Pre-Amplifier Factor(dB)
3. Margin value = Emission Level – Limit value
4. The other emission levels were very low against the limit of frequency range 30MHz~1000MHz.

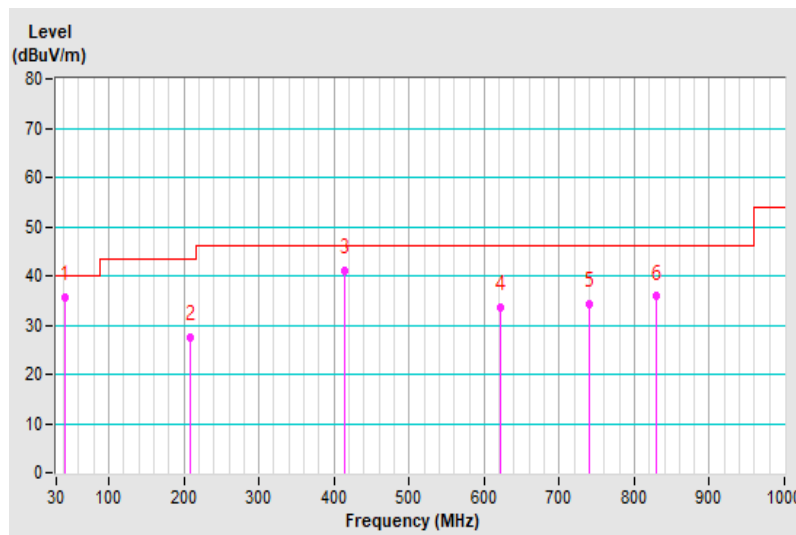

4.2 Conducted Emission Measurement

4.2.1 Limits of Conducted Emission Measurement

Frequency (MHz)	Conducted Limit (dBuV)	
	Quasi-peak	Average
0.15 - 0.5	66 - 56	56 - 46
0.50 - 5.0	56	46
5.0 - 30.0	60	50

Note: 1. The lower limit shall apply at the transition frequencies.

2. The limit decreases in line with the logarithm of the frequency in the range of 0.15 to 0.50MHz.

4.2.2 Test Instruments

Description & Manufacturer	Model no.	Serial No.	Calibrated Date	Calibrated Until
Test Receiver R&S	ESR3	102412	2022/1/22	2023/1/21
LISN Schwarzbeck	NSLK 8128	8128-244	2021/11/11	2022/11/10
LISN Schwarzbeck	NNLK8129	8129229	2021/5/20	2022/5/19
DC LISN Schwarzbeck	NNLK 8121	8121-808	2021/4/18	2022/4/17
LISN Schwarzbeck	NNLK 8121	8121-731	2021/4/28	2022/4/27
LISN R&S	ENV216	101196	2021/4/26	2022/4/25
LISN R&S	ESH3-Z5	100220	2021/11/25	2022/11/24
LISN R&S	ESH3-Z6	844950/018	2021/7/25	2022/7/24
DC LISN R&S	ESH3-Z6	100219	2021/7/25	2022/7/24
High Voltage Probe Schwarzbeck	TK9420	00982	2021/12/24	2022/12/23
RF Coaxial Cable Commate	5D-FB	Cable-CO5-01	2022/1/28	2023/1/27
Attenuator STI	STI02-2200-10	NO.4	2021/9/3	2022/9/2
50 Ohms Terminator LYNICS	0900510	E1-01-305	2022/2/9	2023/2/8
Isolation Transformer Erika Fiedler	D-65396	017	2021/9/9	2022/9/8
Software BVADT	Cond_V7.3.7.4	NA	NA	NA

Note: 1. The test was performed in Linkou Conduction 05.

2. The VCCI Site Registration No. C-11093.

3. Tested Date: 2022/3/10

4.2.3 Test Procedures

- The EUT was placed 0.4 meters from the conducting wall of the shielded room with EUT being connected to the power mains through a line impedance stabilization network (LISN). Other support units were connected to the power mains through another LISN. The two LISNs provide 50 ohm/ 50uH of coupling impedance for the measuring instrument.
- Both lines of the power mains connected to the EUT were checked for maximum conducted interference.
- The frequency range from 150kHz to 30MHz was searched. Emission levels under (Limit - 20dB) was not recorded.

NOTE: The resolution bandwidth and video bandwidth of test receiver is 9kHz for quasi-peak detection (QP) and average detection (AV) at frequency 0.15MHz-30MHz.

4.2.4 Deviation from Test Standard

No deviation.

4.2.5 Test Setup

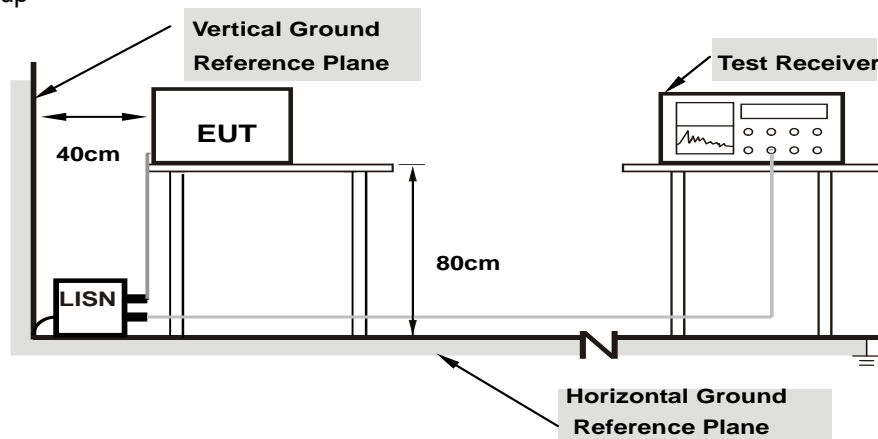

Note: 1.Support units were connected to second LISN.

For the actual test configuration, please refer to the attached file (Test Setup Photo).

4.2.6 EUT Operating Conditions

Same as item 4.1.6.

4.2.7 Test Results

Frequency Range	150kHz ~ 30MHz	Detector Function	Quasi-Peak (QP) / Average (AV)
-----------------	----------------	-------------------	--------------------------------

Phase Of Power : Line (L)										
No	Frequency (MHz)	Correction Factor (dB)	Reading Value (dBuV)		Emission Level (dBuV)		Limit (dBuV)		Margin (dB)	
			Q.P.	AV.	Q.P.	AV.	Q.P.	AV.	Q.P.	AV.
1	0.24375	9.87	39.08	30.69	48.95	40.56	61.97	51.97	-13.02	-11.41
2	0.41953	9.89	24.13	3.36	34.02	13.25	57.46	47.46	-23.44	-34.21
3	0.86484	9.91	28.70	19.92	38.61	29.83	56.00	46.00	-17.39	-16.17
4	1.37500	9.94	29.89	24.48	39.83	34.42	56.00	46.00	-16.17	-11.58
5	2.63281	9.97	30.03	18.51	40.00	28.48	56.00	46.00	-16.00	-17.52
6	3.29688	9.99	22.56	8.53	32.55	18.52	56.00	46.00	-23.45	-27.48
7	22.12500	10.43	18.31	9.24	28.74	19.67	60.00	50.00	-31.26	-30.33

Remarks:

1. Q.P. and AV. are abbreviations of quasi-peak and average individually.
2. The emission levels of other frequencies were very low against the limit.
3. Margin value = Emission level – Limit value
4. Correction factor = Insertion loss + Cable loss
5. Emission Level = Correction Factor + Reading Value

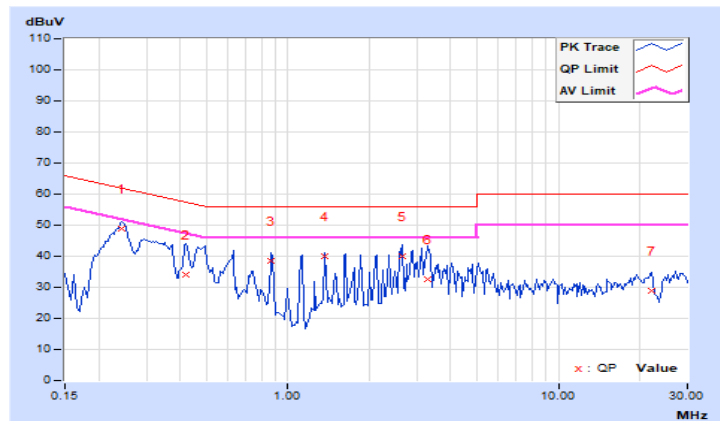

Frequency Range	150kHz ~ 30MHz	Detector Function	Quasi-Peak (QP) / Average (AV)
-----------------	----------------	-------------------	--------------------------------

Phase Of Power : Neutral (N)										
No	Frequency (MHz)	Correction Factor (dB)	Reading Value (dBuV)		Emission Level (dBuV)		Limit (dBuV)		Margin (dB)	
			Q.P.	AV.	Q.P.	AV.	Q.P.	AV.	Q.P.	AV.
1	0.24375	9.88	40.62	31.82	50.50	41.70	61.97	51.97	-11.47	-10.27
2	0.44297	9.90	30.67	8.35	40.57	18.25	57.01	47.01	-16.44	-28.76
3	0.62266	9.91	33.05	28.70	42.96	38.61	56.00	46.00	-13.04	-7.39
4	1.12891	9.94	30.46	23.04	40.40	32.98	56.00	46.00	-15.60	-13.02
5	2.84375	9.99	27.65	11.97	37.64	21.96	56.00	46.00	-18.36	-24.04
6	13.56250	10.32	26.62	20.32	36.94	30.64	60.00	50.00	-23.06	-19.36

Remarks:

1. Q.P. and AV. are abbreviations of quasi-peak and average individually.
2. The emission levels of other frequencies were very low against the limit.
3. Margin value = Emission level – Limit value
4. Correction factor = Insertion loss + Cable loss
5. Emission Level = Correction Factor + Reading Value

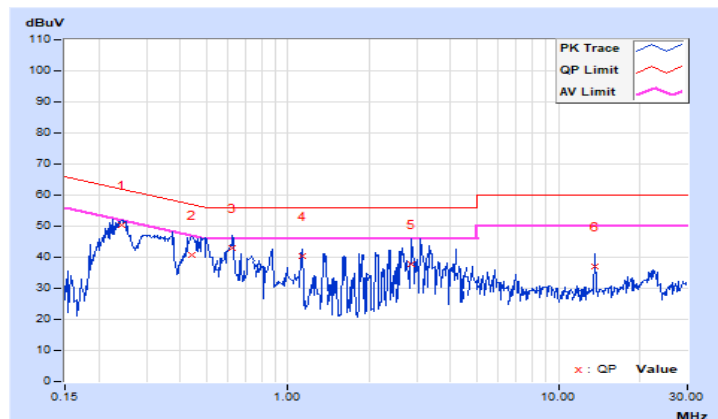

4.3 Frequency Stability

4.3.1 Limits of Frequency Stability Measurement

The frequency tolerance of the carrier signal shall be maintained within $\pm 0.01\%$ of the operating frequency over a temperature variation of -20 degrees to 50 degrees C at normal supply voltage, and for a variation in the primary supply voltage from 85% to 115% of the rated supply voltage at a temperature of 20 degrees C.

4.3.2 Test Setup

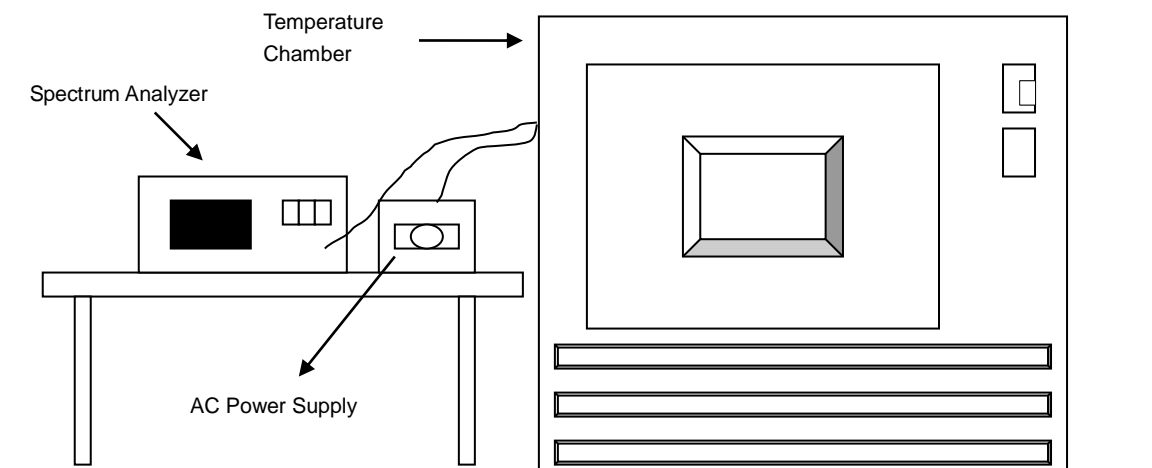

4.3.3 Test Instruments

Refer to section 4.1.2 to get information of above instrument.

4.3.4 Test Procedure

- The EUT was placed inside the environmental test chamber and powered by nominal AC voltage.
- Turned the EUT on and coupled its output to a spectrum analyzer.
- Turned the EUT off and set the chamber to the highest temperature specified.
- Allowed sufficient time (approximately 30 min) for the temperature of the chamber to stabilize then turned the EUT on and measured the operating frequency.
- Repeated step c and d with the temperature chamber set to the lowest temperature.
- The test chamber was allowed to stabilize at $+25$ degree C for a minimum of 30 minutes. The supply voltage was then adjusted on the EUT from 85% to 115% and the frequency record.

4.3.5 Deviation from Test Standard

No deviation.

4.3.6 EUT Operating Conditions

Same as Item 4.1.6.

4.3.7 Test Result

Frequency Stability Versus Temp.									
Temp. (°C)	Power Supply (Vac)	0 Minute		2 Minute		5 Minute		10 Minute	
		Reading (MHz)	Drift (%)	Reading (MHz)	Drift (%)	Reading (MHz)	Drift (%)	Reading (MHz)	Drift (%)
50	120	13.55995	-0.00037	13.55995	-0.00037	13.55995	-0.00037	13.55995	-0.00037
40	120	13.56001	0.00007	13.56	0.00000	13.56001	0.00007	13.56001	0.00007
30	120	13.55996	-0.00029	13.55997	-0.00022	13.55997	-0.00022	13.55997	-0.00022
20	120	13.56006	0.00044	13.56006	0.00044	13.56007	0.00052	13.56006	0.00044
10	120	13.56003	0.00022	13.56003	0.00022	13.56003	0.00022	13.56003	0.00022
0	120	13.55994	-0.00044	13.55995	-0.00037	13.55995	-0.00037	13.55994	-0.00044
-10	120	13.56001	0.00007	13.56001	0.00007	13.56001	0.00007	13.56001	0.00007
-20	120	13.56003	0.00022	13.56003	0.00022	13.56003	0.00022	13.56004	0.00029

Frequency Stability Versus Voltage									
Temp. (°C)	Power Supply (Vac)	0 Minute		2 Minute		5 Minute		10 Minute	
		Reading (MHz)	Drift (%)	Reading (MHz)	Drift (%)	Reading (MHz)	Drift (%)	Reading (MHz)	Drift (%)
20	138	13.56006	0.00044	13.56006	0.00044	13.56007	0.00052	13.56006	0.00044
	120	13.56006	0.00044	13.56006	0.00044	13.56007	0.00052	13.56006	0.00044
	102	13.56006	0.00044	13.56006	0.00044	13.56007	0.00052	13.56006	0.00044

4.4 20dB Bandwidth

4.4.1 Limits Of 20dB Bandwidth Measurement

The 20dB bandwidth shall be specified in operating frequency band.

4.4.2 Test Setup

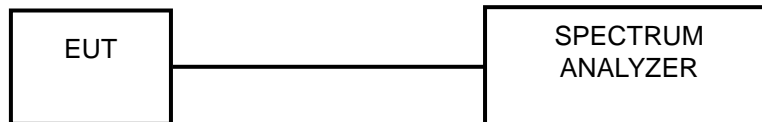

4.4.3 Test Instruments

Refer to section 4.1.2 to get information of above instrument.

4.4.4 Test Procedures

The bandwidth of the fundamental frequency was measured by spectrum analyzer with 10kHz RBW and 30kHz VBW. The 20dB bandwidth is defined as the total spectrum the power of which is higher than peak power minus 20dB.

4.4.5 Deviation from Test Standard

No deviation.

4.4.6 EUT Operating Conditions

The software provided by client to enable the EUT under transmission condition continuously at lowest, middle and highest channel frequencies individually.

4.4.7 Test Results

Frequency (MHz)	20dB Bandwidth (kHz)	Pass/Fail
13.56	2.6628	Pass

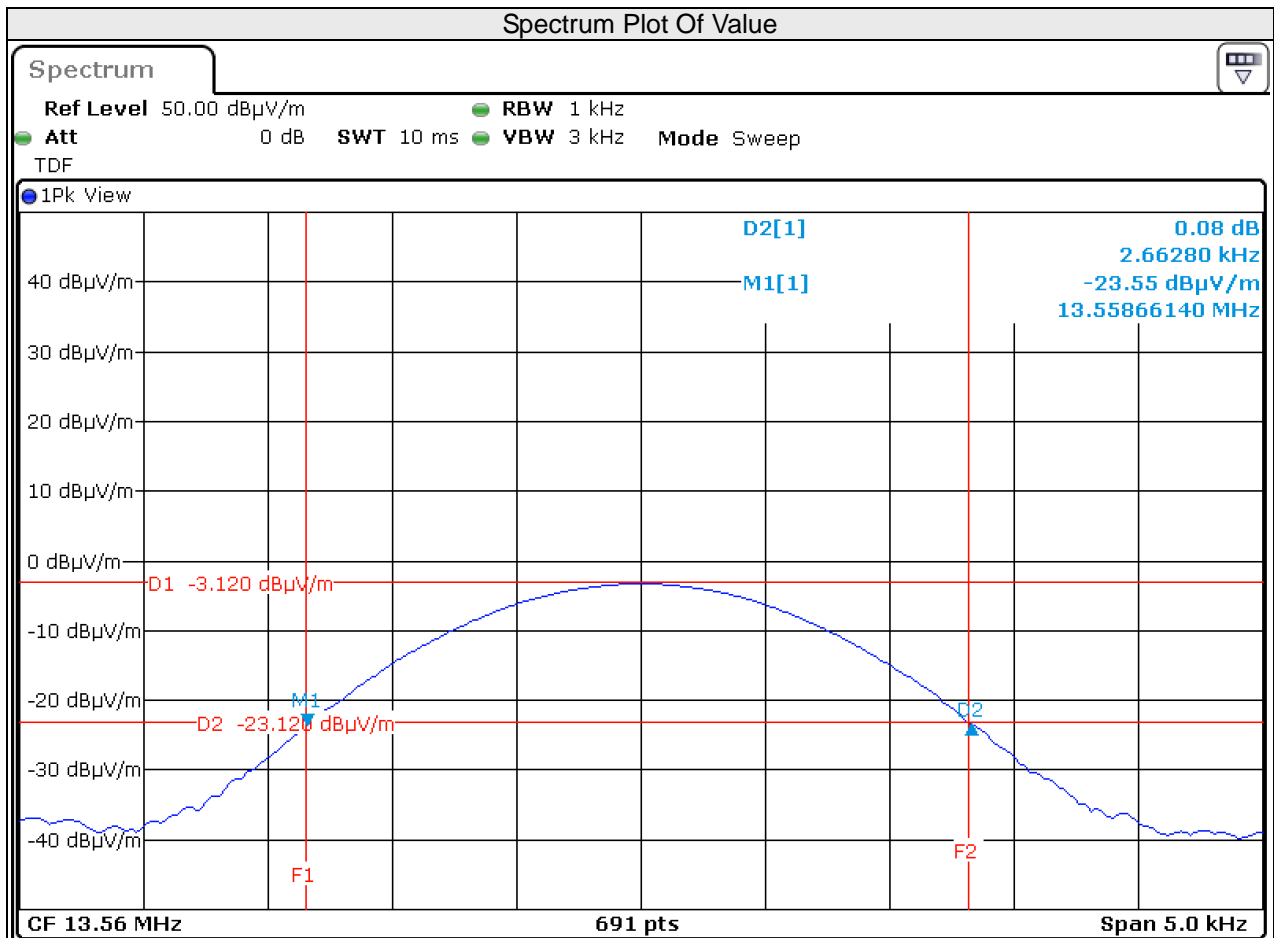

Note: The signal look like CW signal, so RBW can't be match 1~5 % OBW.

5 Pictures of Test Arrangements

Please refer to the attached file (Test Setup Photo).

Appendix – Information of the Testing Laboratories

We, Bureau Veritas Consumer Products Services (H.K.) Ltd., Taoyuan Branch, were founded in 1988 to provide our best service in EMC, Radio, Telecom and Safety consultation. Our laboratories are FCC recognized accredited test firms and accredited and approved according to ISO/IEC 17025.

If you have any comments, please feel free to contact us at the following:

Lin Kou EMC/RF Lab

Tel: 886-2-26052180

Fax: 886-2-26051924

Hsin Chu EMC/RF/Telecom Lab

Tel: 886-3-6668565

Fax: 886-3-6668323

Hwa Ya EMC/RF/Safety Lab

Tel: 886-3-3183232

Fax: 886-3-3270892

Email: service.adt@tw.bureauveritas.com

Web Site: www.bureauveritas-adt.com

The address and road map of all our labs can be found in our web site also.

--- END ---