

UPC-V312-D525 Panel PC

1.4.4 Right Side Panel

The right side panel of the panel PC provides access to a USB 2.0 port (**Figure 1-6**).

Enable or disable this USB port by pressing the function keys: **Fn** + **Q**.

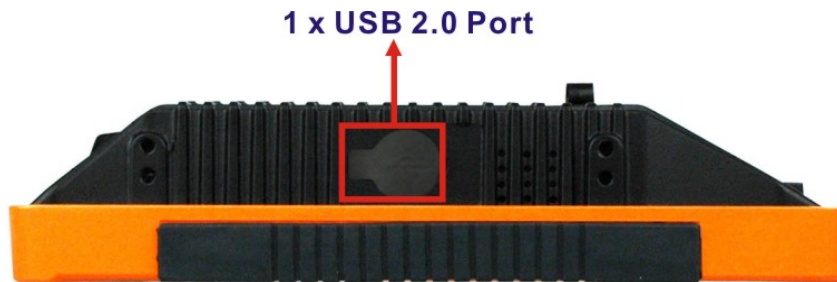

Figure 1-6: Left Side View

1.4.5 Rear Panel

The rear panel has retention screw holes that support a wall-mounting bracket.

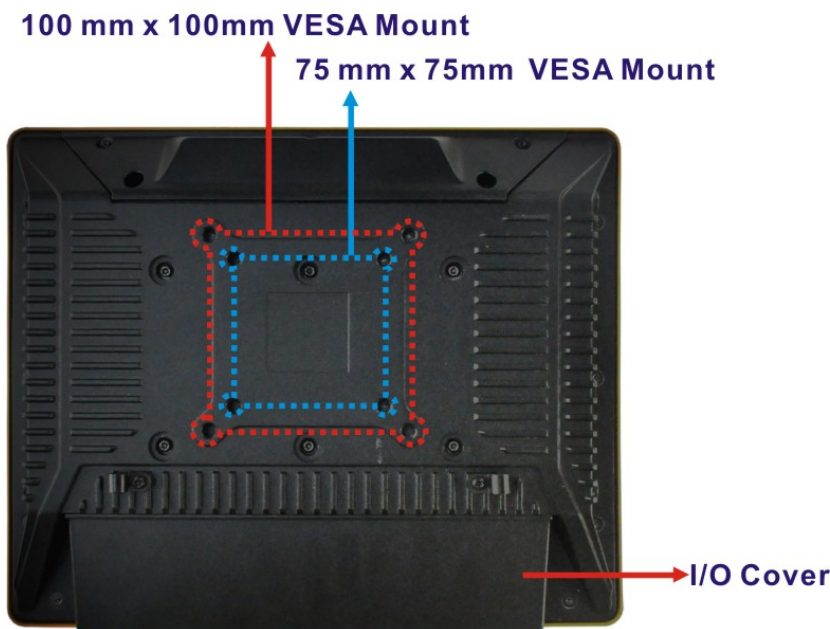

Figure 1-7: Rear View

1.4.6 Frame (Function Keys)

An aluminum frame surrounds the TFT LCD screen. The aluminum frame of the UPC-V312-D525 contains several function keys that control audio volume, LCD brightness and some other system components.



Figure 1-8: Function Key Locations

The following table describes the function of these function keys.

Buttons	Function	Buttons	Function
	Function		
	LCD on/off	+	Enable/Disable RFID
	Audio volume down	+	Mute audio
	Audio volume up	+	Enable/Disable webcam
	Brightness up	+	Enable/Disable right side USB port
	Brightness down	+	Power on/off (Turn on: press 3 seconds Turn off: press 6 seconds)

Table 1-3: Function Keys



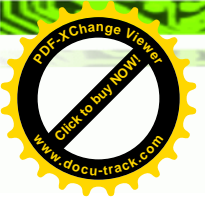

UPC-V312-D525 Panel PC

1.5 Dimensions

The dimensions of the UPC-V312-D525 are shown in **Figure 1-9** and listed below.

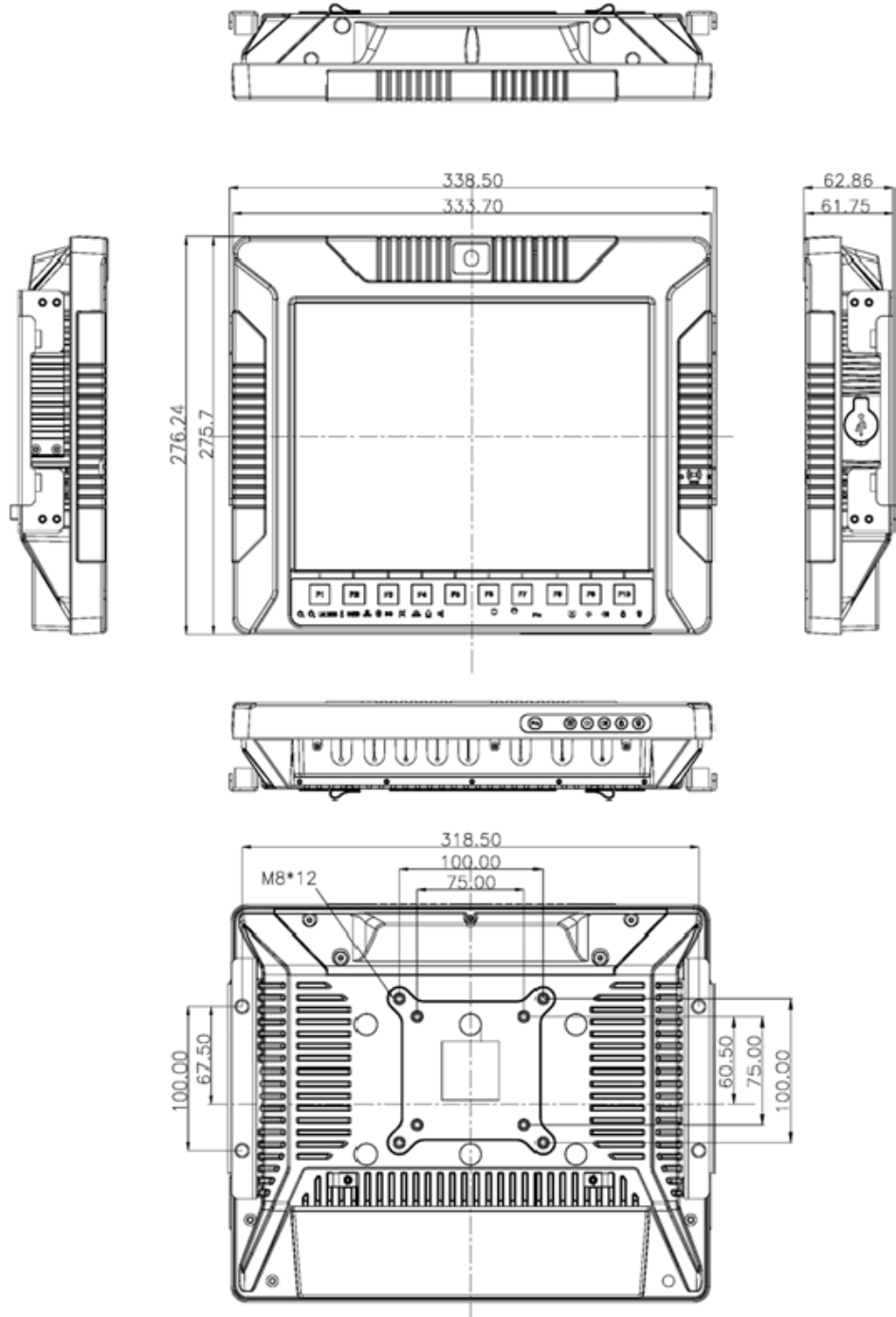
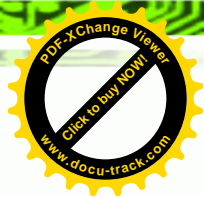

Figure 1-9: UPC-V312-D525 Dimensions (mm)



1.6 Specifications

The technical specifications for the UPC-V312-D525 system are listed in **Table 1-4**.

Specification	UPC-V312-D525
LCD Size	12.1"
Max. Resolution	1024 x 768 (XGA)
Brightness	600 cd/m ²
Contrast Ratio	700:1
LCD Color	16.2 M
Pixel Pitch (mm)	0.240 (H) x 0.240 (V)
Viewing Angle (H-V)	130 (H) / 150 (V)
Backlight MTBF	50,000 hours
SBC Model	UPC-12AT-D525-R10
CPU	1.8 GHz Intel® Atom™ D525 dual-core processor
Chipsets	ICH8M
Memory	On-board 1.0 GB DDR3 SDRAM SO-DIMM
Ethernet	Realtek RTL8111E PCIe GbE controller supports ASF 2.0
SSD	CF Type II socket or mSATA (optional)
Watchdog Timer	Software Programmable supports 1 sec. ~ 255 sec. system reset
Camera	1.3 megapixel webcam supports AF, AE and AWB
RFID (Optional)	Frequency: 125KHz or 13.56MHz Reading distance: 5~7cm Supports ISO 14443A Mifare or EM standard
Communication	Dual-band 2.4/5GHz Wi-Fi 802.11a/b/g/n



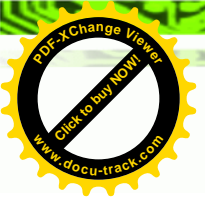

UPC-V312-D525 Panel PC

	Optional GPS receiver Optional 3.75G HSUPA USB module
Audio	2 x Audio speakers 1 x Digital microphone 1 x Line-out connector 1 x Mic-in connector
Expansion	1 x PCIe Mini interface (installed with wireless LAN 802.11 a/b/g/n module) 1 x PCIe Mini slots for mSATA (optional)
Construction Material	Aluminum die-casting (front panel) Extruded aluminum alloy (chassis)
Mounting	Wall, Stand, Arm (VESA 100 mm x 100 mm and 75 mm x 75 mm with M8 screws)
Front Panel Color	Orange and black
Dimensions (W x H x D) (mm)	338.5 x 276.25 x 62.86
Weight (Net/Gross)	4.5kg/5.0kg
Operating Temperature	-20°C ~ 50°C
Storage Temperature	-35°C ~ 85°C
Relative Humidity	5%~90%, non-condensing
IP level (full system)	IP 65
Touch Screen	5-wire resistive type
Vibration	MIL-STD-810F 514.5C-2 (with CF card or SSD)
Shock	Half-sine wave shock 3G; 11ms; 3 shocks per axis
Power Adapter	65 W Input: 100 VAC ~ 240 VAC @ 50 Hz / 60 Hz

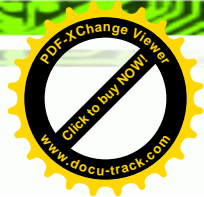

	Output: 19 VDC
Power Requirement	Redundant dual DC input Terminal block: 9 (+/-3) V ~ 36 V DC jack: 10.5 (+/-0.3) V ~ 36 V
Max. Power Consumption	52 W
I/O Ports and Switches	1 x 9~36 V DC In terminal block (Power 1) 1 x 10.5~36 V DC In connector (Power 2) 1 x CAN-bus connector 1 x RS-232 port (COM1) 1 x RS-422/485 port (COM2) 5 x USB 2.0 connectors (four on the I/O panel, one on the side panel) 1 x GbE connector 2 x Audio jacks (Line-out, Mic-in) 1 x VGA connector 1 x AT/ATX power mode switch 1 x ACC on/off switch 1 x Reset button

Table 1-4: System Specifications



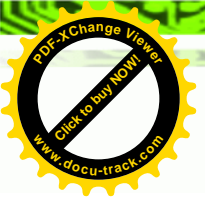

Chapter

2

Unpacking



2.1 Unpacking

To unpack the panel PC, follow the steps below:



WARNING!

The front side LCD screen has a protective plastic cover stuck to the screen. Only remove the plastic cover after the panel PC has been properly installed. This ensures the screen is protected during the installation process.

- Step 1:** Use box cutters, a knife or a sharp pair of scissors that seals the top side of the external (second) box.
- Step 2:** Open the external (second) box.
- Step 3:** Use box cutters, a knife or a sharp pair of scissors that seals the top side of the internal (first) box.
- Step 4:** Lift the monitor out of the boxes.
- Step 5:** Remove both polystyrene ends, one from each side.
- Step 6:** Pull the plastic cover off the panel PC.
- Step 7:** Make sure all the components listed in the packing list are present.

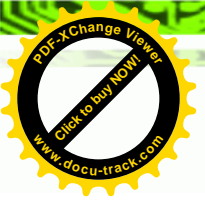





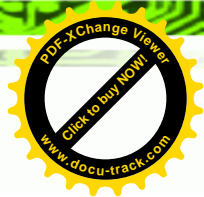

2.2 Packing List

The UPC-V312-D525 panel PC is shipped with the following components:

Quantity	Item	Image
1	UPC-V312-D525 panel PC	
1	Power adapter (P/N: 63040-010065-010-RS)	
1	Power cord (P/N: 32702-000401-100-RS)	
1	Power transfer cord (P/N: 32000-089400-RS)	
1	RJ-45 to DB-9 COM port cable (P/N: 32005-000200-200-RS)	
1	RS-422 cable (P/N: 32205-002400-100-RS)	
1	Remote control (P/N: 7Z000-SLPCB001-RS)	



8	VESA mount screw (M8) (P/N: 44325-080081-RS)	
8	VESA mount screw (M4*8) (P/N: 44005-040082-RS)	
2	Mounting bracket (side panels) (P/N: 41003-0382C2-00-RS)	
1	Screwdriver (P/N: 45019-001004-00)	
1	One Key Recover CD (P/N: IEI-7B000-000478-RS)	
1	User manual CD and driver CD	

If any of these items are missing or damaged, contact the distributor or sales representative immediately.



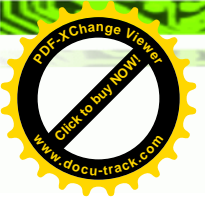

Chapter

3

Installation



3.1 Anti-static Precautions



WARNING:

Failure to take ESD precautions during the maintenance of the EP series may result in permanent damage to the EP series and severe injury to the user.

Electrostatic discharge (ESD) can cause serious damage to electronic components, including the UPC-V312-D525. Dry climates are especially susceptible to ESD. It is therefore critical that whenever the UPC-V312-D525 is accessed internally, or any other electrical component is handled, the following anti-static precautions are strictly adhered to.

- **Wear an anti-static wristband:** - Wearing a simple anti-static wristband can help to prevent ESD from damaging the board.
- **Self-grounding:** - Before handling the board touch any grounded conducting material. During the time the board is handled, frequently touch any conducting materials that are connected to the ground.
- **Use an anti-static pad:** - When configuring the UPC-V312-D525, place it on an anti-static pad. This reduces the possibility of ESD damaging the UPC-V312-D525.
- **Only handle the edges of the PCB:** - When handling the PCB, hold the PCB by the edges.

3.2 Installation Precautions

When installing the panel PC, please follow the precautions listed below:

- **Power turned off:** When installing the panel PC, make sure the power is off. Failing to turn off the power may cause severe injury to the body and/or damage to the system.
- **Certified Engineers:** Only certified engineers should install and modify onboard functionalities.
- **Anti-static Discharge:** If a user opens the rear panel of the panel PC, to



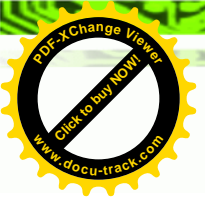

UPC-V312-D525 Panel PC

configure the jumpers or plug in added peripheral devices, ground themselves first and wear an anti-static wristband.

3.3 Preinstalled Components

The following components are all preinstalled.

- Motherboard
- TFT LCD screen
- DDR3 memory module
- Resistive type touch screen
- Stereo speakers
- Wireless module
- Webcam

Preinstalled OEM customizations may include the following.

- Different DDR3 memory module
- RFID reader
- GPS receiver
- 3.75G / HSUPA USB module
- mSATA



CAUTION:

The UPC-V312-D525 is an IP 65 compliant panel PC. A user cannot open the rear cover and install any components inside the UPC-V312-D525. Doing so may compromise the system's waterproof performance. To install components in the system, please contact the system vendor, reseller or an IEI sales person directly.

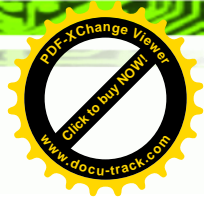

3.4 CF Card Installation

The UPC-V312-D525 has one CF Type II slot. To install the CF card, follow the instructions below.

Step 1: **Locate the CF card socket.** The CF card socket is located on the left side panel of the UPC-V312-D525.

Step 2: **Remove the CF card slot panel** by removing the four retention screws.



NOTE:

Please use the screw driver that comes with the UPC-V312-D525 to remove the screws on the chassis.



Figure 3-1: Remove the CF Card Slot Panel

Step 3: **Install the CF Card.** Correctly align the CF card with the socket and insert the CF card into the socket. See **Figure 3-2**.



UPC-V312-D525 Panel PC



Figure 3-2: CF Card Installation

Step 4: Reinstall the CF card slot panel.

3.5 Mounting the System



WARNING:

When mounting the panel PC onto an arm or onto the wall, it is better to have more than one person to help with the installation to make sure the panel PC does not fall down and get damaged.

The panel PC is VESA (Video Electronics Standards Association) compliant and can be mounted on an arm, a stand or a bracket with a 100 mm/75 mm interface pad. M8 and M4 mounting screws can both be used for VESA mount. The VESA mount retention screw holes of the UPC-V312-D525 are shown in **Figure 3-3**.

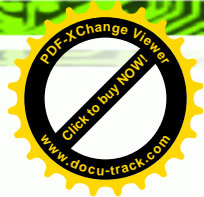

Figure 3-3: VESA Mount Retention Screw Holes

To enhance the stability, the user can use the mounting brackets, which are shipped with the UPC-V312-D525 and can be attached on both side panels. An additional mounting device is required for the mounting brackets.

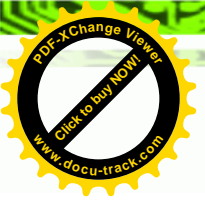

Figure 3-4: Mounting Brackets (Side Panels)



NOTE:

When mounting the UPC-V312-D525 on a vehicle, it is recommended to use the **M8** mounting screws on the real panel. A special mounting bracket is required for M8 mounting screw. Please contact IEI for more information.



UPC-V312-D525 Panel PC

The following installation options are available:

- Arm mounting
- Stand mounting
- Wall mounting

The mounting methods are described below.

3.5.1 Arm Mounting

The UPC-V312-D525 can be installed on any arm that supports the standard VESA mounting interface. An example arm is shown below.



Figure 3-5: VESA Compliant Arm

To install the UPC-V312-D525 on the arm, follow the directions below.



NOTE:

Make sure the arm supports standard VESA mounting. The UPC-V312-D525 uses a VESA mounting to attach to the arm.

Step 1: The arm is purchased separately. Follow the instructions in the arm's user manual to securely attach the arm to the wall.

Step 2: Once the mounting arm has been firmly attached to the surface, lift the panel PC onto the interface pad of the mounting arm.

Step 3: Align the retention screw holes on the mounting arm interface with those in the panel PC. The arm mount retention screw holes are shown in **Figure 3-3**.

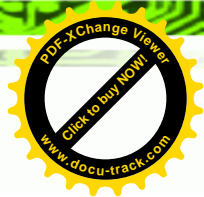

Step 4: Secure the flat panel PC to the interface pad by inserting four retention screws through the bottom of the mounting arm interface pad and into the flat panel PC.

3.5.2 Stand Mounting

The UPC-V312-D525 can be installed on any stand that supports the standard VESA mounting interface. An example stand is shown below.



Figure 3-6: VESA Compliant Stand

To install the UPC-V312-D525 on the stand, follow the directions below.

Step 1: Locate the screw holes on the rear of the UPC-V312-D525. This is where the stand bracket will be attached. The stand mount retention screw holes are shown in **Figure 3-3**.

Step 2: Align the bracket with the screw holes.

Step 3: Insert the retention screws into the screw holes to secure the bracket to the UPC-V312-D525.

3.5.3 Wall Mounting

To mount the panel PC onto the wall, please follow the steps below.

Step 1: Select the location on the wall for the wall-mounting bracket.

Step 2: Carefully mark the locations of the four brackets screw holes on the wall.

Step 3: Drill four pilot holes at the marked locations on the wall for the bracket retention screws.



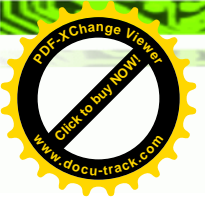

UPC-V312-D525 Panel PC

Step 4: Align the wall-mounting bracket screw holes with the pilot holes.

Step 5: Secure the mounting-bracket to the wall by inserting the retention screws into the four pilot holes and tightening them (Figure 3-7).

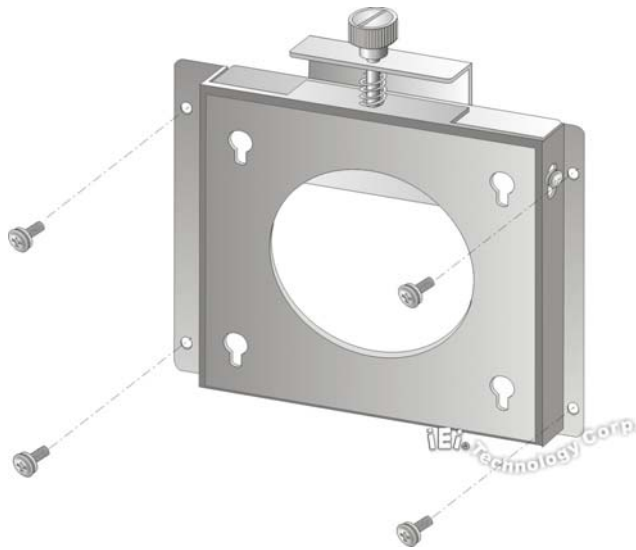

Figure 3-7: Wall-mounting Bracket

Step 6: Insert the four monitor mounting screws provided in the wall mounting kit into the four screw holes on the rear panel of the flat panel PC and tighten until the screw shank is secured against the rear panel (Figure 3-8).

Step 7: Align the mounting screws on the monitor rear panel with the mounting holes on the bracket.

Step 8: Carefully insert the screws through the holes and gently pull the monitor downwards until the monitor rests securely in the slotted holes (Figure 3-8). Ensure that all four of the mounting screws fit snugly into their respective slotted holes.

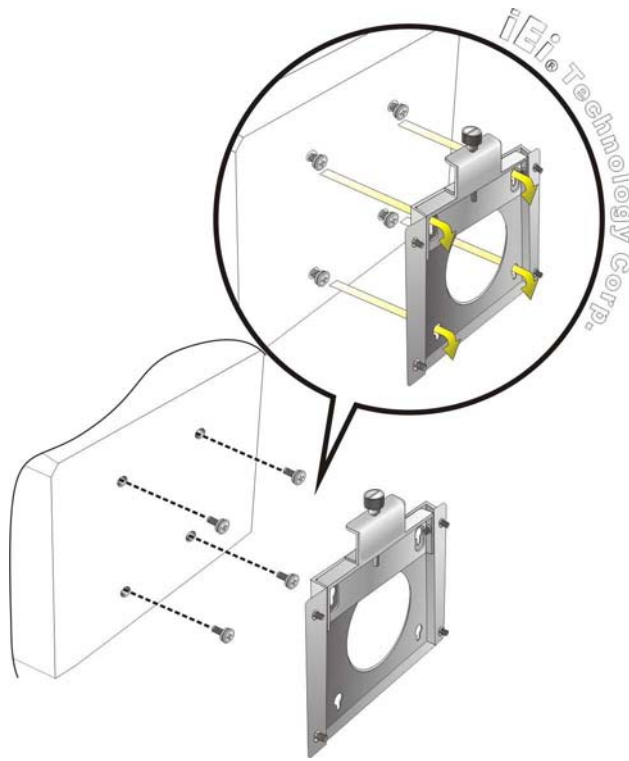

Figure 3-8: Chassis Support Screws



NOTE:

In the diagram below the bracket is already installed on the wall.

-
- Step 9:** Secure the panel PC by fastening the retention screw of the wall-mounting bracket. (Figure 3-9).



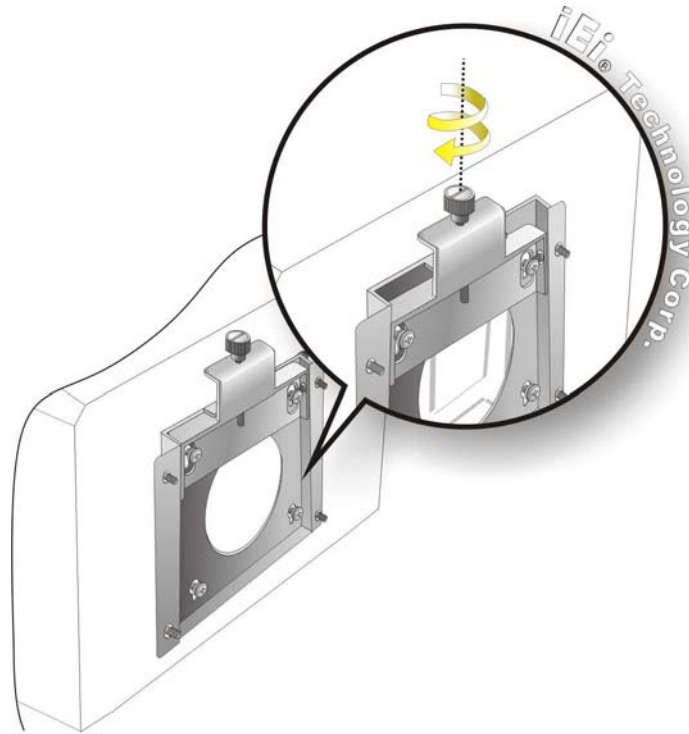
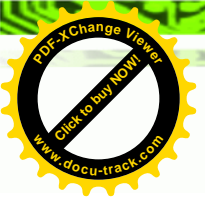

Figure 3-9: Secure the Panel PC

3.6 Bottom Panel Connectors

The bottom panel of the UPC-V312-D525 contains I/O connectors, switches and a reset button. These connectors are protected by an I/O cover. Detailed descriptions of the connectors and cabling can be found in the subsections below.

3.6.1 External Peripheral Device Connection

To install external peripheral devices to the UPC-V312-D525, please follow the steps below.

Step 1: Remove the I/O cover by removing the eight retention screws as shown in

Figure 3-10.



Figure 3-10: I/O Cover Retention Screws

Step 2: Connect the cable from the external peripheral device to the corresponding connector of the UPC-V312-D525 (Figure 3-11).

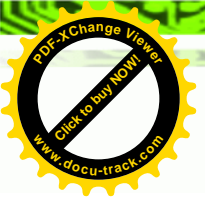

Figure 3-11: External Peripheral Device Connection

Step 3: Take out a rubber gasket from the I/O cover (Figure 3-12).



Figure 3-12: Rubber Gasket Removal



UPC-V312-D525 Panel PC

Step 4: Remove some rubber rings from the gasket to make the gasket fit perfectly to the size of the cable (**Figure 3-13**).



Figure 3-13: Rubber Gasket and Cable

Step 5: Repeat steps to other connected cables.

Step 6: Install the I/O cover and make sure each rubber gasket snaps into place tightly.



Figure 3-14: Reinstall the I/O Cover

Step 7: Secure the I/O cover by the previously removed retention screws.

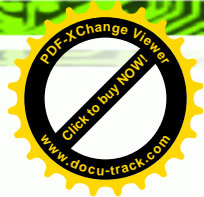

Figure 3-15: External Peripheral Device Connection Complete

3.6.2 ACC Mode Selection

The ACC mode can be turned on or off. The setting is made through the ACC mode switch on the bottom panel as shown below.



Figure 3-16: ACC Mode Switch

3.6.3 AT/ATX Power Mode Selection

The UPC-V312-D525 supports both AT and ATX power modes. The setting can be made through the AT/ATX power mode switch on the bottom panel as shown below.

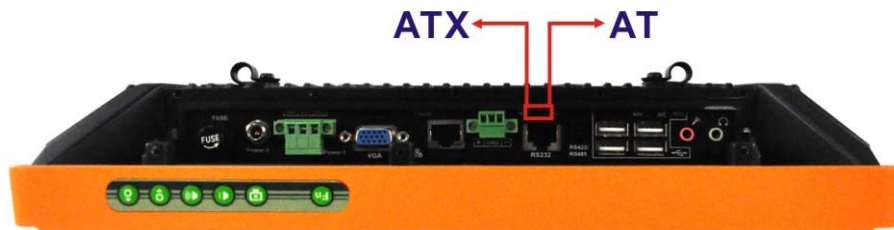

Figure 3-17: AT/ATX Power Mode Switch



UPC-V312-D525 Panel PC

3.6.4 Audio Connectors

The audio jacks connect to external audio devices.

- **Microphone (Pink):** Connects a microphone.
- **Line Out port (Green):** Connects to a headphone or a speaker. With multi-channel configurations, this port can also connect to front speakers.

3.6.5 CAN-bus Terminal Block

There is one 3-pin CAN-bus terminal block. The pinouts are shown in **Figure 3-18**

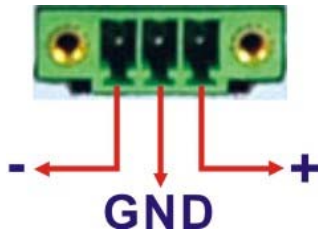

Figure 3-18: CAN-bus Terminal Block Pinouts

3.6.6 LAN Connector

The LAN connector allows connection to an external network. The pinouts of the RJ-45 LAN connector is shown below.

Pin	Description	Pin	Description
1	MDI0+	2	MDI0-
3	MDI1+	4	MDI1-
5	MDI2+	6	MDI2-
7	MDI3+	8	MDI3-

Table 3-1: LAN Pinouts

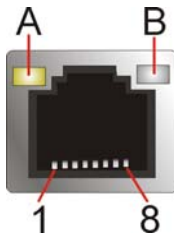

Figure 3-19: RJ-45 Ethernet Connector

The RJ-45 Ethernet connector has two status LEDs, one green and one yellow. See **Figure 3-19**.

LED	Description	LED	Description
A	on: linked blinking: data is being sent/received	B	off: 10 Mb/s green: 100 Mb/s orange: 1000 Mb/s

Table 3-2: RJ-45 Ethernet Connector LEDs

To connect the UPC-V312-D525 to a network through the RJ-45 LAN connector, follow the steps below.

- Step 1:** Locate the RJ-45 connector. The location of the RJ-45 connectors is shown in **Figure 1-4**.
- Step 2:** **Align the connectors.** Align the RJ-45 connector on the LAN cable with one of the RJ-45 connectors on the UPC-V312-D525. See **Figure 3-20**.

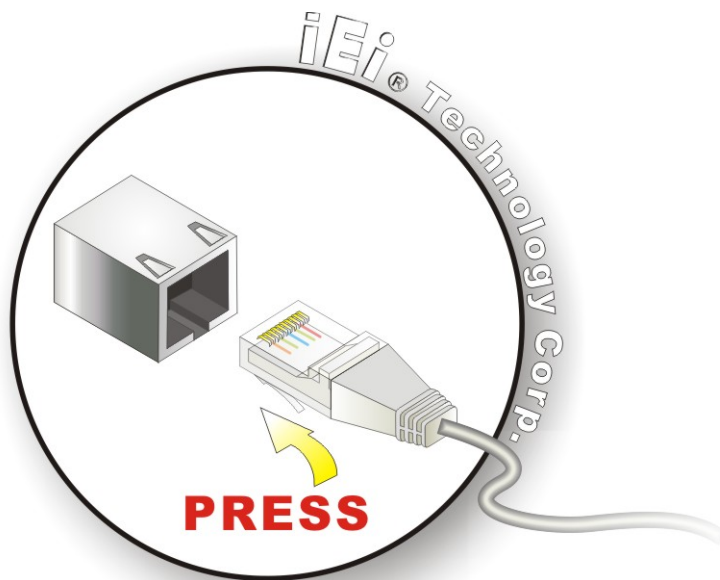

Figure 3-20: LAN Connection

- Step 3:** **Insert the LAN cable RJ-45 connector.** Once aligned, gently insert the LAN cable RJ-45 connector into the on-board RJ-45 connector.



UPC-V312-D525 Panel PC

3.6.7 Power Input 1, 3-pin Terminal Block

- CN Label:** POWER 1
CN Type: 3-pin terminal block
CN Location: See **Figure 1-4**
CN Pinouts: See **Figure 3-21**

Connect the leads of a 9V~36V DC power supply into the terminal block. Make sure that the power and ground wires are attached to the correct sockets of the connector.

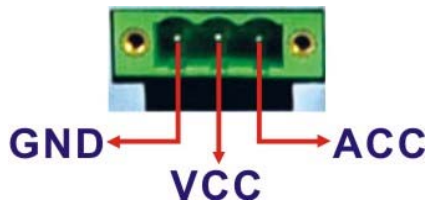

Figure 3-21: 3-pin Terminal Block Pinouts

3.6.8 Power Input 2, DIN Connector

- CN Label:** POWER 2
CN Type: DIN connector
CN Location: See **Figure 1-4**

The power connector connects to the 10.5 V ~ 36 V DC power adapter.

3.6.9 RJ-45 RS-232 Serial Port

- CN Label:** RS 232
CN Type: RJ-45
CN Location: See **Figure 1-4**
CN Pinouts: See **Table 3-3** and **Figure 3-22**

A RS-232 serial port device can be connected to the RJ-45 RS-232 serial port on the bottom panel. The pinouts of the RJ-45 RS-232 serial port is shown below.

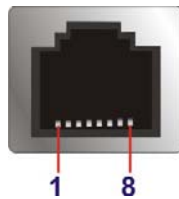

Figure 3-22: RJ-45 RS-232 Serial Port

Pin	Description	Pin	Description
1	NDCD1	5	NTX1
2	NDSR1	6	NCTS1
3	NRX1	7	NDTR1
4	NRTS1	8	NR11

Table 3-3: RJ-45 RS-232 Serial Port Pinouts

To install the RS-232 devices, follow the steps below.

- Step 1:** Locate the RJ-45 RS-232 connector. The location of the RJ-45 RS-232 connector is shown in **Figure 1-4**.
- Step 2:** **Insert the RJ-45 connector.** Insert the RJ-45 connector on the RJ-45 to DB-9 COM port cable to the RJ-45 RS-232 connector on the UPC-V312-D525. See **Figure 3-23**.

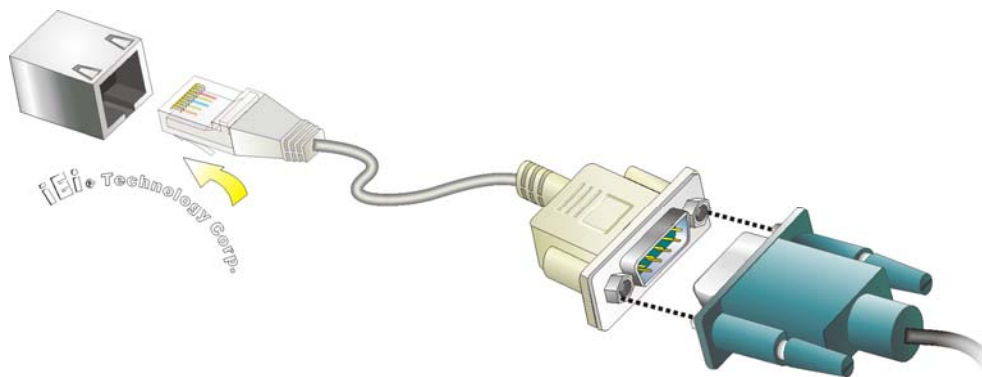
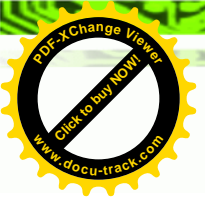

Figure 3-23: RJ-45 RS-232 Serial Device Connection

- Step 3:** **Insert the serial connector.** Insert the DB-9 connector of a serial device into the DB-9 connector on the RJ-45 to DB-9 COM port cable.





UPC-V312-D525 Panel PC

Step 4: **Secure the connector.** Secure the serial device connector to the external interface by tightening the two retention screws on either side of the connector.

3.6.10 RS-422/485 Serial Port

- CN Label:** RS 422/485
- CN Type:** 4-pin connector
- CN Location:** See **Figure 1-4**
- CN Pinouts:** See **Table 3-4** and **Figure 3-24**

A RS-422/485 serial port device can be connected to the RS-422/485 serial port on the bottom panel. The pinouts of the RS-422/485 serial port is shown below.



Figure 3-24: RS-422/485 Serial Port

Pin	Description	Pin	Description
1	RXD485+_R	3	TXD485+_R
2	RXD485#_R	4	TXD485#_R

Table 3-4: RS-422/485 Serial Port Pinouts

To install the RS-422/485 devices, follow the steps below.

- Step 1:** Locate the RS-422/RS485 connector. The location of the RS-422/RS-485 connector is shown in Figure 1-4.
- Step 2:** **Connect the RS-422/485 connector to the RS-422/485 cable.** The RS-422/485 cable can be found in the packing list and is shown in **Figure 3-25**.



Figure 3-25: RS-422/485 Cable

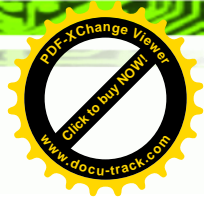

Step 3: Insert the serial connector. Insert the DB-9 connector of a serial device into the DB-9 connector on the RS-422/485 cable.

Step 4: Secure the connector. Secure the serial device connector to the external interface by tightening the two retention screws on either side of the connector.

Step 5: The DB-9 connector pinouts are listed below.

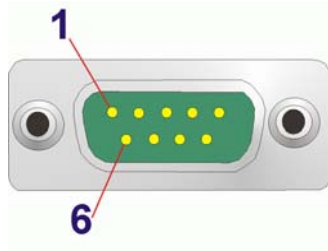

Figure 3-26: RS-422/485 Serial Port (DB-9)

Pin	RS-422	RS-485
1	TX-	DATA-
2	TX+	DATA+
3	RX+	--
4	RX-	--
5	--	--
6	--	--
7	--	--
8	--	--
9	--	--

Table 3-5: RS-422/485 Serial Port Pinouts

3.6.11 USB Connectors

- CN Label:** USB
- CN Type:** USB port
- CN Location:** See Figure 1-4
- CN Pinouts:** See Table 3-6



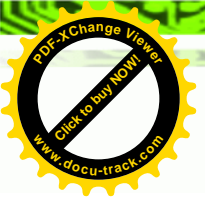

UPC-V312-D525 Panel PC

The USB ports are for attaching USB peripheral devices to the system. The pinouts of the USB port is shown below.

Pin	Description	Pin	Description
1	VCC	5	VCC
2	DATA-	6	DATA-
3	DATA+	7	DATA+
4	GROUND	8	GROUND

Table 3-6: USB Port Pinouts

To install a USB device, follow the steps below.

Step 1: Locate the USB connectors. The locations of the USB connectors are shown in **Figure 1-4**.

Step 2: Align the connectors. Align the USB device connector with one of the connectors. See **Figure 3-27**.

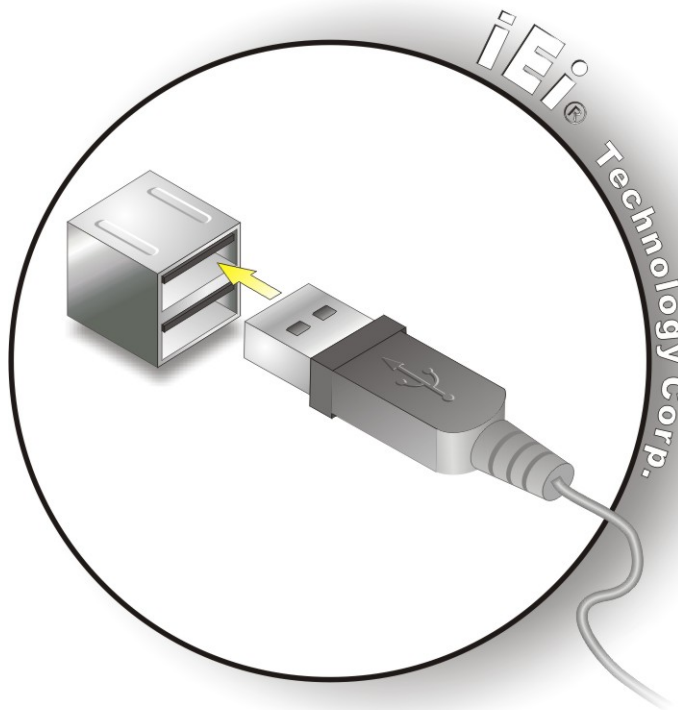

Figure 3-27: USB Device Connection

Step 3: Insert the device connector. Once aligned, gently insert the USB device connector into the on-board connector.

3.6.12 VGA Connector

- CN Label:** VGA
- CN Type:** 15-pin Female
- CN Location:** See **Figure 1-4**
- CN Pinouts:** See **Figure 3-28** and **Table 3-7**

The VGA connector connects to a monitor that supports dual display. The pinouts of the VGA connector is shown below.

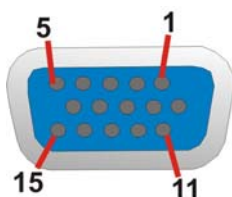

Figure 3-28: VGA Connector

Pin	Description	Pin	Description
1	RED	2	GREEN
3	BLUE	4	NC
5	GND	6	GND
7	GND	8	GND
9	VCC / NC	10	GND
11	NC	12	DDC DAT
13	HSYNC	14	VSYNC
15	DDCCLK		

Table 3-7: VGA Connector Pinouts

To connect the UPC-V312-D525 to a second display, follow the steps below,

Step 1: Locate the female DB-15 connector. The location of the female DB-15 connector is shown in Figure 1-4.



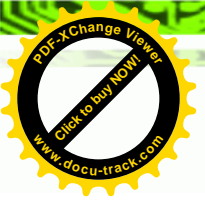

UPC-V312-D525 Panel PC

Step 2: **Align the VGA connector.** Align the male DB-15 connector on the VGA screen cable with the female DB-15 connector on the external peripheral interface.

Step 3: **Insert the VGA connector** Once the connectors are properly aligned with the insert the male connector from the VGA screen into the female connector on the UPC-V312-D525. See **Figure 3-29**.

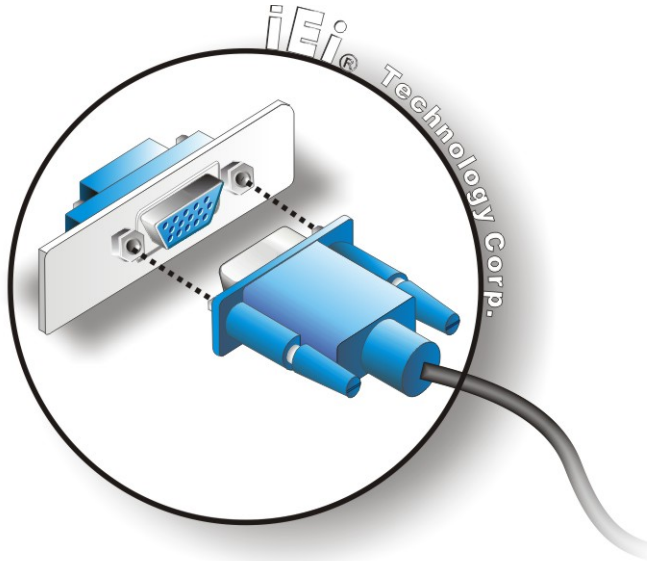

Figure 3-29: VGA Connector



CAUTION:

It is suggested that not to open the rear cover and replace any components. If the components fail, it must be shipped back to IEI to be replaced. If the system has failed, please contact the system vendor, reseller or an IEI sales person directly.

3.7 Redundant Power

The UPC-V312-D525 is a system that supports redundant power. The redundant power input increases the reliability of the system while preventing data loss and system corruption from sudden power failure. The system can instantly and uninterruptedly switch to the second power input when the main power is unavailable or in low voltage capacity.

There are two power connectors on the bottom panel. Power 1 connector is a 3-pin terminal block that supports ACC On signal. Power 2 connector is a DIN connector that can directly connect to a power adapter. The supported power input voltages are:

- **Power 1 (Terminal block):** 9 V (+/-3 V) ~ 36 V
- **Power 2 (DC jack):** 10.5 V (+/-0.3 V) ~ 36 V

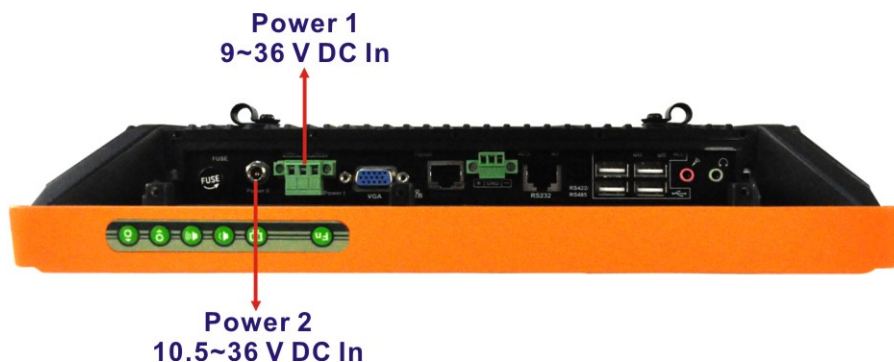
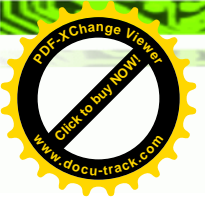

Figure 3-30: Power Connectors

When the system is in ACC On mode, the main power input is from the Power 1 connector. When the system is in ACC Off mode, the main power input is from the Power 2 connector. The ACC on/off mode is selected by the ACC on/off switch on the bottom panel.

(Figure 3-16).

The following sections describe how redundant power works in ACC On mode and ACC Off mode.



UPC-V312-D525 Panel PC

3.7.1 ACC ON



NOTE:

In ACC On mode, the Power 1 connector must connect to the ACC on signal to be able to control system power.

The ACC On mode is designed for vehicle applications. When the UPC-V312-D525 is in ACC On mode, the main power input is the Power 1 connector and the backup power is from the Power 2 connector.

3.7.1.1 Boot-up

When both power connectors are connected to the power source with over 9 V, the two power LEDs on the front panel remain off until **the ACC ON signal jumps from low to high**. The user can choose AT power mode or ATX power mode to control the system. The following flow diagrams show the boot-up process and the LED status in AT and ATX power modes.

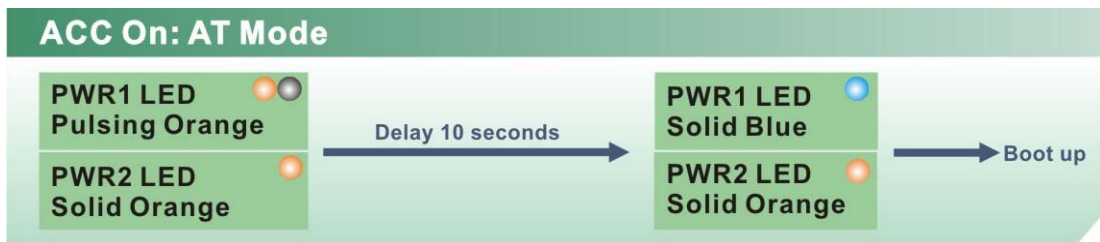

Figure 3-31: ACC On: AT Mode

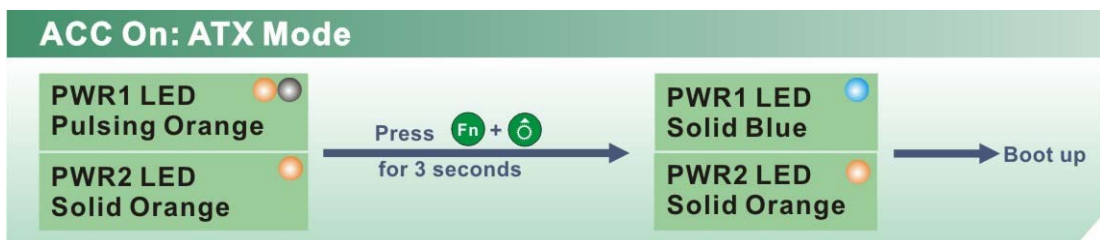

Figure 3-32: ACC On: ATX Mode

3.7.1.2 Switch to Backup Power

During operation, system power will switch from Power 1 to Power 2 automatically when the following situations occur:

- Power 1 < 9V and Power 2 > 10.5V
- Power 1 > 9V, but the ACC ON signal jump from high to low
- Power 1 is unplugged and Power 2 > 10.5V



The following flow diagram shows how the power is switched between Power 1 and Power 2 and their LED statuses.



Figure 3-33: ACC On: Switch Between PWR1 and PWR2

3.7.1.3 Shutdown

The system will shutdown in the following situations:

- Power 1 < 9V and Power 2 < 10.5V
- Power 1 > 9V, Power 2 < 10.5V and ACC ON signal jump from high to low
- Press  +  buttons for 6 seconds

The following flow diagram shows the system shutdown process and the LED statuses.



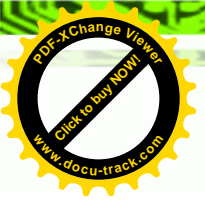

UPC-V312-D525 Panel PC

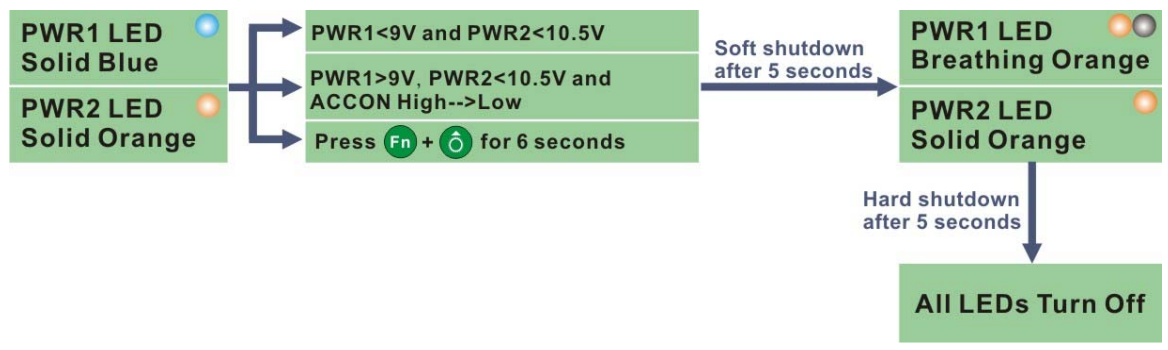

Figure 3-34: ACC On: Shutdown

NOTE:

To turn on the system in ATX power mode, press the button for three seconds. Press these two buttons for six seconds to turn off the system.

3.7.2 ACC OFF

When the UPC-V312-D525 is in ACC Off mode, the main power input is the Power 2 connector and the backup power is from the Power 1 connector.

3.7.2.1 Boot-up

When both power connectors are connected to the power source with over 9 V, the two power LEDs on the front panel turn on. The user can choose AT power mode or ATX power mode to control the system. The following flow diagrams show the boot-up process and the LED status in AT and ATX power modes.

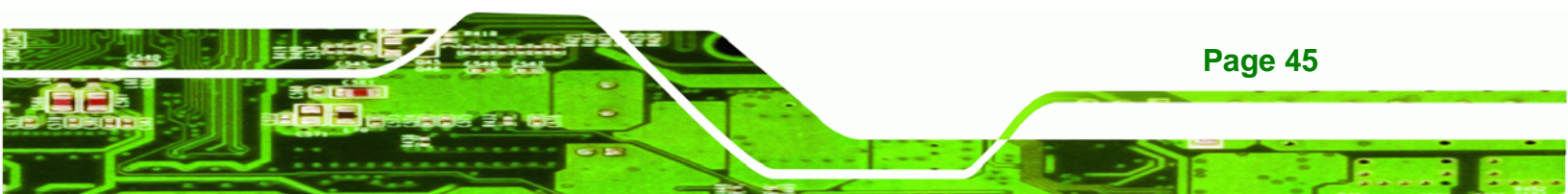

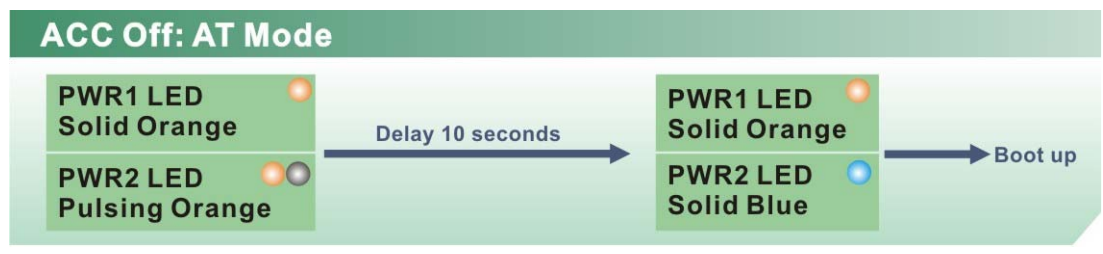
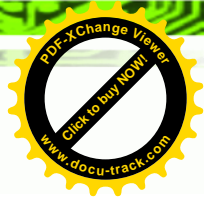

Figure 3-35: ACC Off: AT Mode

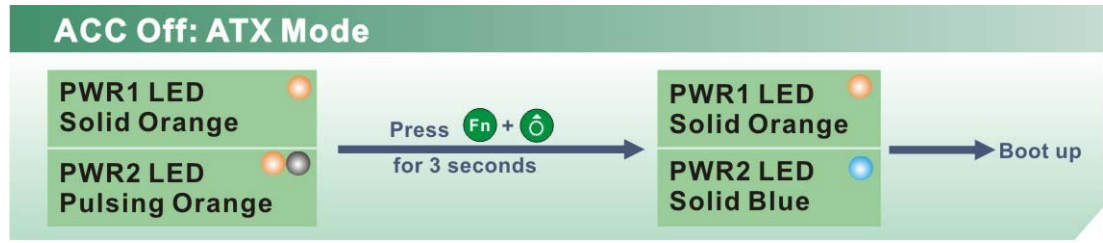

Figure 3-36: ACC Off: ATX Mode

3.7.2.2 Switch to Backup Power

During operation, system power switches from Power 2 to Power 1 automatically when the following situations occur:

- Power 2 < 10.5V and Power 1 > 9V
- Power 2 is unplugged and Power 1 > 9V

The following flow diagram shows how the power is switched between Power 2 and Power 1 and their LED statuses.

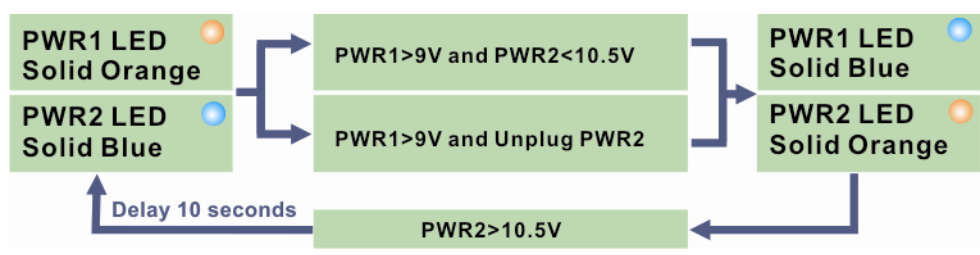
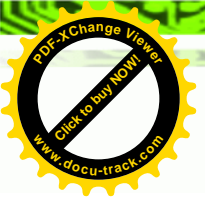

Figure 3-37: ACC Off: Switch Between PWR1 and PWR2





UPC-V312-D525 Panel PC

3.7.2.3 Shutdown

The system will shutdown in the following situations:

- Power 2 < 10.5V and Power 1 < 9V
- Press **Fn** + **⏻** buttons for 6 seconds

The following flow diagram shows the system shutdown process and the LED statuses.

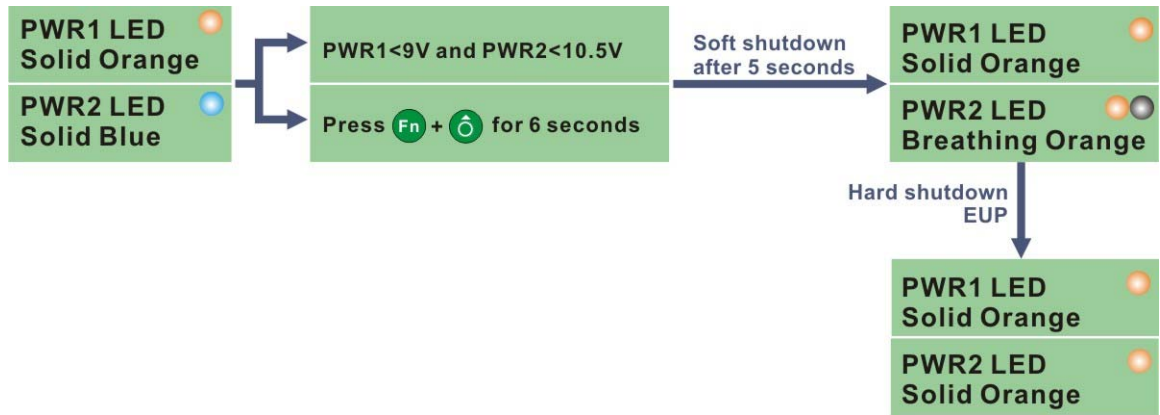

Figure 3-38: ACC Off: Shutdown



NOTE:

The power LED turns off when the power cable is unplugged from the system.

3.8 Remote Control

The UPC-V312-D525 comes with a remote control for easy configuration. **Figure 3-39** shows the remote control and its function keys.



Figure 3-39: Remote Control

- **System On/Off:** Press this button to turn the UPC-V312-D525 on or off.
- **LCD On/Off.** Press this button to turn the LCD monitor on or off.
- **Auto-Dimming.** Press this button to turn the auto-dimming function on or off.
- **Brightness.** Use these control buttons to adjust the brightness of the LCD screen.
- **Volume.** Press these buttons to adjust the audio volume level.