



RADIO REPORT FCC 47 CFR Part 15C ISED Canada RSS-247 Frequency hopping systems operating within the 2400 – 2483.5 MHz band	
Report Reference No	G0M-1707-6725-TFC247BT-V02
Testing Laboratory	Eurofins Product Service GmbH
Address	Storkower Str. 38c 15526 Reichenwalde Germany
Accreditation	 <p>A2LA Accredited Testing Laboratory, Certificate No.: 1983.01 FCC Test Firm Designation Number: DE0008 IC Testing Laboratory site: 3470A-2</p>
Applicant	Leica Geosystems AG
Address	Heinrich Wild Strasse 9435 Heerbrugg SWITZERLAND
Test Specification	According to FCC/ISED rules
Standard	47 CFR Part 15C RSS-247, Issue 2, 2017-02
Non-Standard Test Method	None
Test Scope	partial compliance test
Equipment under Test (EUT):	
Product Description	External GNSS Antenna
Model(s)	GG04 plus
Additional Model(s)	None
Brand Name(s)	Leica Geosystems AG
Hardware Version(s)	1.0.1
Software Version(s)	1.0.12
FCC-ID	RFD-SAGG04P
IC	3177A-SAGG04P
Test Result	PASSED

Possible test case verdicts:		
required by standard but not tested	N/T	
not required by standard	N/R	
test object does meet the requirement	P(PASS)	
test object does not meet the requirement	F(FAIL)	
Testing:		
Test Lab Temperature	20 - 23 °C	
Test Lab Humidity	32 – 38 %	
Date of receipt of test item	2017-09-06	
Report:		
Compiled by	Sebastian Suckow	
Tested by (+ signature) (Responsible for Test)	Sebastian Suckow	
Approved by (+ signature) (Head of Lab)	Christian Weber	
Date of Issue	2017-12-11	
Total number of pages	87	
General Remarks:		
<p>The test results presented in this report relate only to the object tested.</p> <p>The results contained in this report reflect the results for this particular model and serial number. It is the responsibility of the manufacturer to ensure that all production models meet the intent of the requirements detailed within this report.</p> <p>This report shall not be reproduced, except in full, without the written approval of the Issuing testing laboratory.</p>		
Additional Comments:		

VERSION HISTORY

Version History			
Version	Issue Date	Remarks	Revised By
01	2017-11-23	Initial Release	
02	2017-12-11	3.2.6 Results updated	S. Suckow

ABBREVIATIONS AND ACRONYMS

Acronyms	
Acronym	Description
BR	Bluetooth Basic Rate mode
EDR	Bluetooth Enhanced Data Rate mode
EUT	Equipment Under Test
FCC	Federal Communications Commission
ISED	Innovation, Science and Economic Development Canada
RBW	Resolution bandwidth
RMS	Root mean square
VBW	Video bandwidth
V _{NOM}	Nominal supply voltage

REPORT INDEX

1	Equipment (Test Item) Under Test.....	6
1.1	Photos – Equipment External.....	7
1.2	Photos – Equipment Internal.....	8
1.3	Photos – Test Setup.....	12
1.4	Support Equipment.....	13
1.5	Test Modes.....	14
1.6	Test Frequencies.....	15
1.7	Sample emission level calculation.....	16
2	Result Summary.....	17
3	Test Conditions and Results.....	18
3.1	Test Conditions and Results - Occupied bandwidth.....	18
3.2	Test Conditions and Results - Transmitter radiated emissions.....	29
3.3	Test Conditions and Results - Receiver radiated emissions.....	32
ANNEX A	Transmitter spurious emissions.....	34
ANNEX B	Receiver spurious emissions.....	78

1 Equipment (Test Item) Under Test

Description	External GNSS Antenna	
Model	GG04 plus	
Additional Model(s)	None	
Brand Name(s)	Leica Geosystems AG	
Serial Number(s)	None	
Hardware Version(s)	1.0.1	
Software Version(s)	1.0.12	
PMN	GG04P	
HVIN	Leica Zeno GG04 plus	
FVIN	1.0.12 (x.y.z: where y and z do not affect RF characteristics)	
HMN	N/A	
FCC-ID	RFD-SAGG04P	
IC	3177A-SAGG04P	
Equipment type	End Product	
Radio type	Transceiver	
Assigned frequency bands	2400 - 2483.5 MHz	
Radio technology	Bluetooth	
Modulation	GFSK, PI/4-DQPSK, 8-DPSK	
Number of antenna ports	1	
Radio Module	Type	Bluetooth BR+EDR / LE Module
	Model	CC2564MODN
	Manufacturer	TI
	HW Version	Unspecified
	SW Version	Unspecified
	FCC-ID	Z64-2564N
	IC	4511-2564N
Antenna	Type	Integrated
	Model	BBL-2450
	Manufacturer	Kuk Electronic AG, CH-9050 Appenzell
	Gain	0
Supply Voltage	V_{NOM}	7.4 VDC
Operating Temperature	T_{NOM}	25 °C
Manufacturer	Leica Geosystems AG Heinrich Wild Strasse 9435 Heerbrugg SWITZERLAND	

1.1 Photos – Equipment External

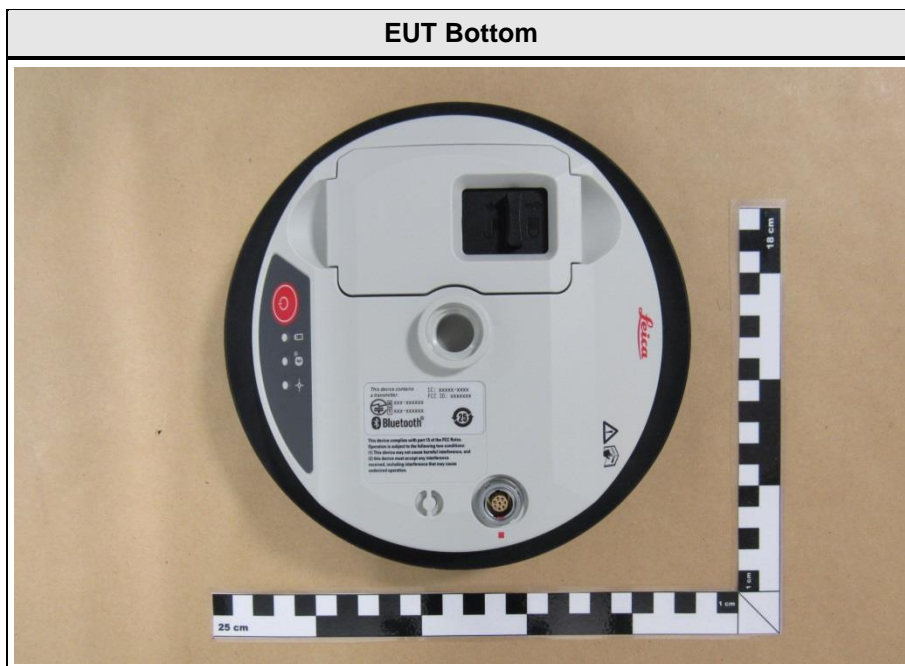
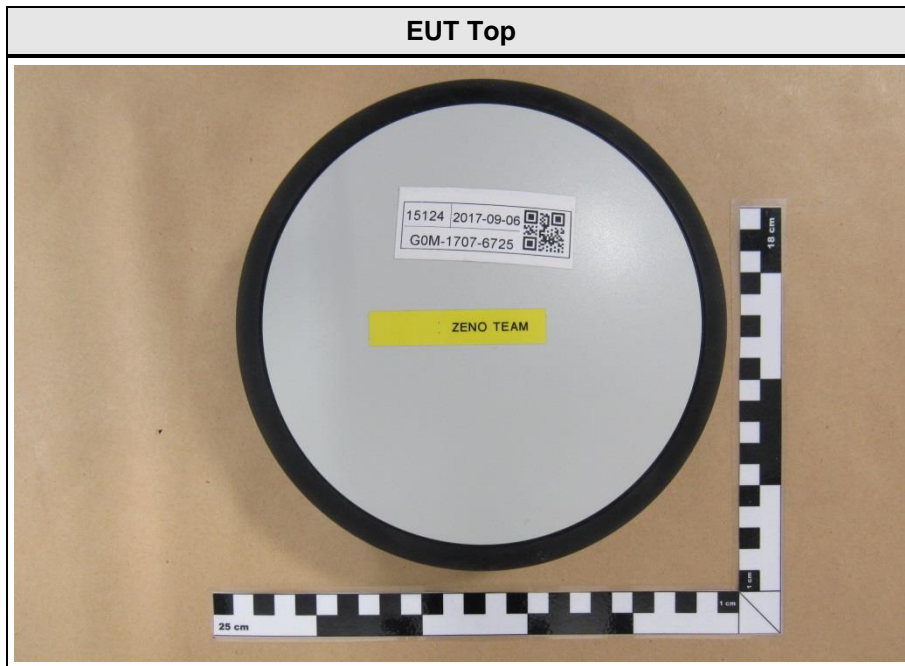

1.2 Photos – Equipment Internal

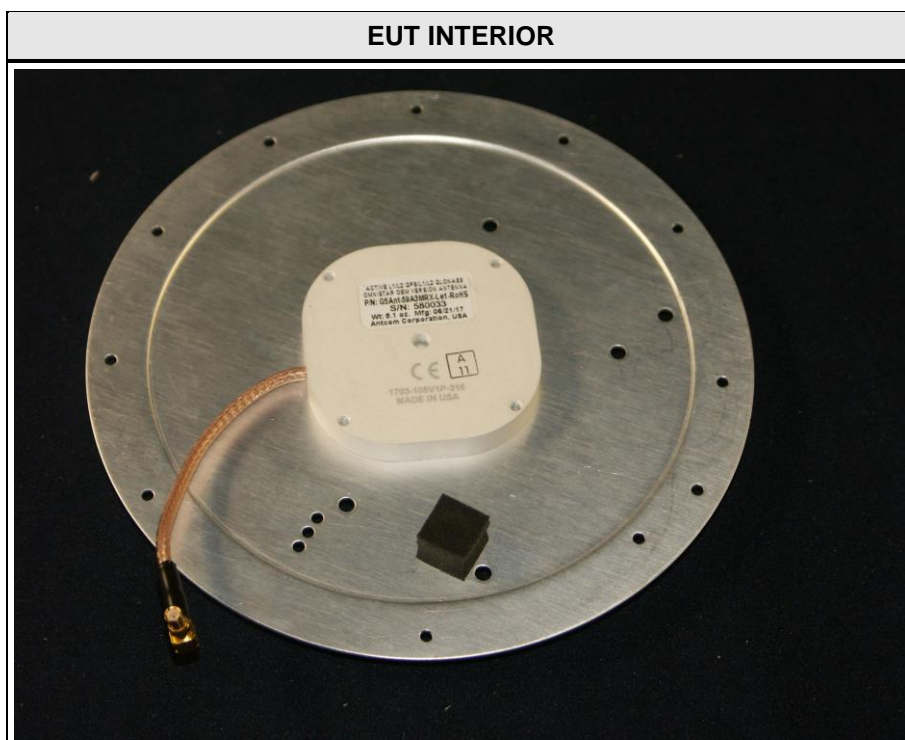
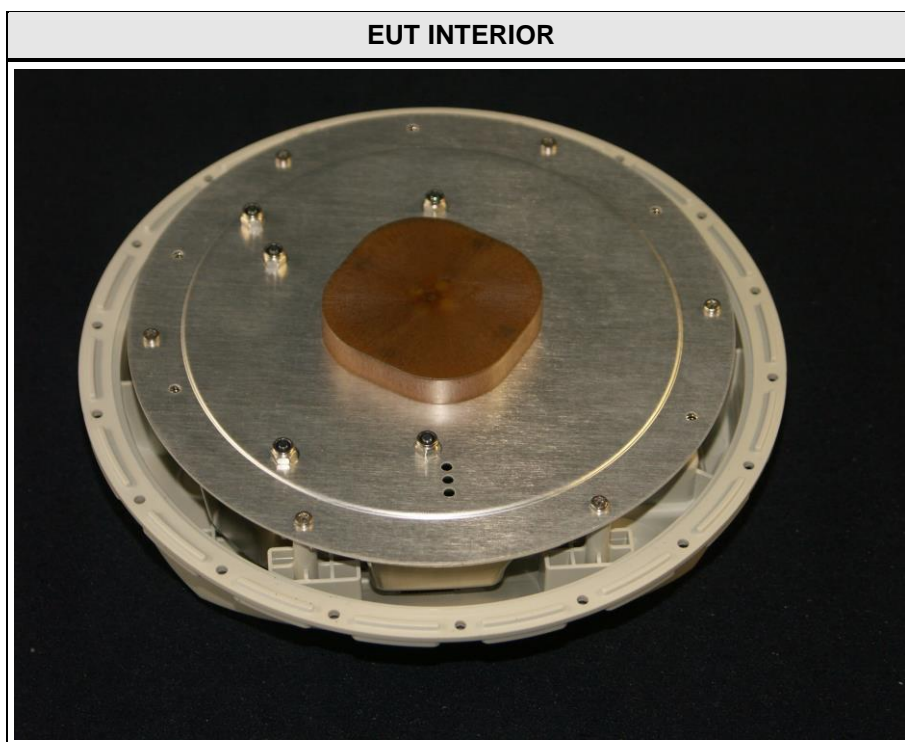

EUT INTERIOR

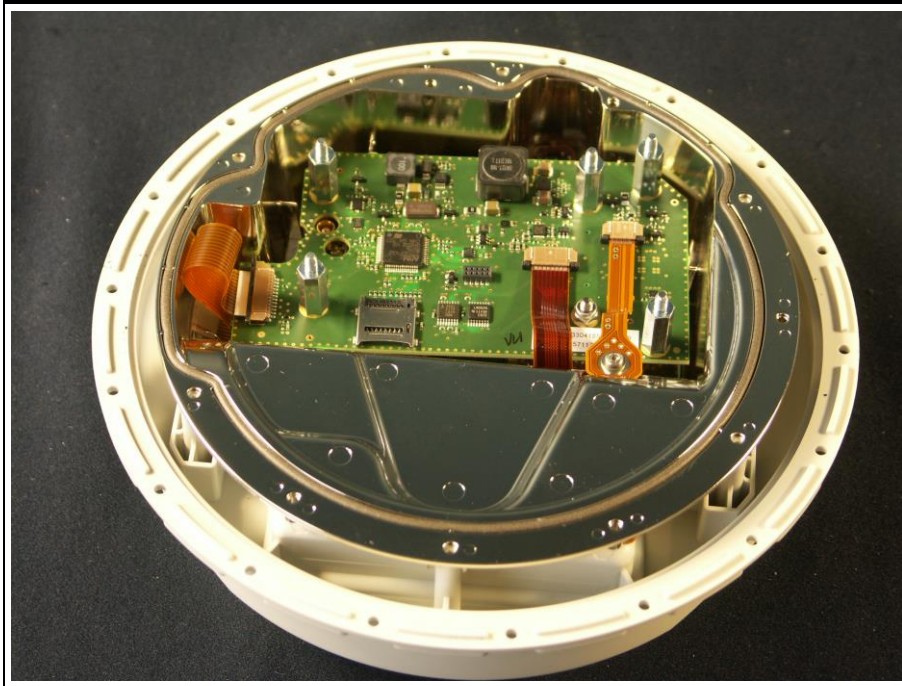

EUT INTERIOR

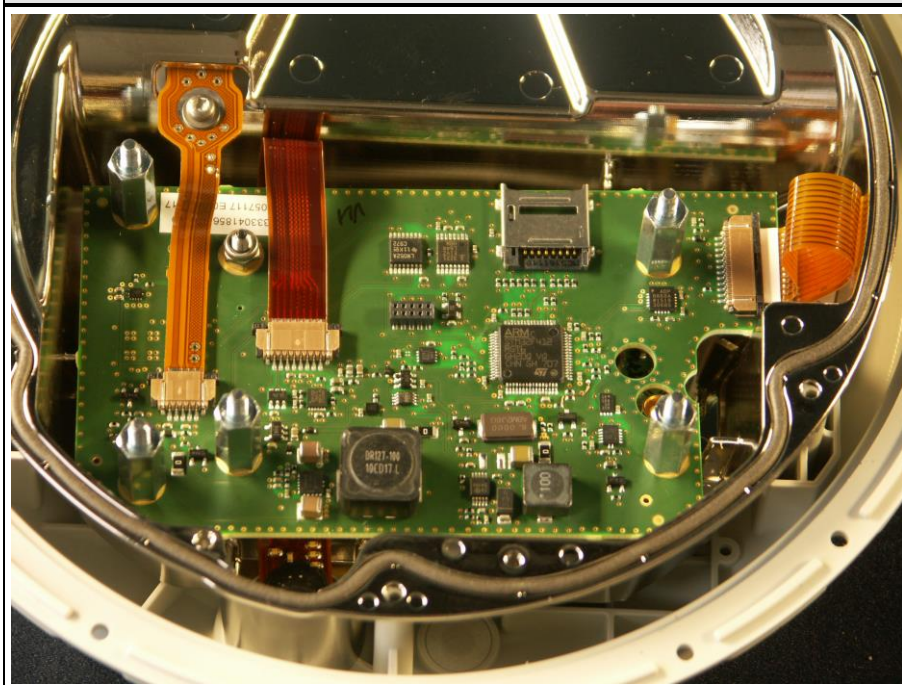

EUT INTERIOR

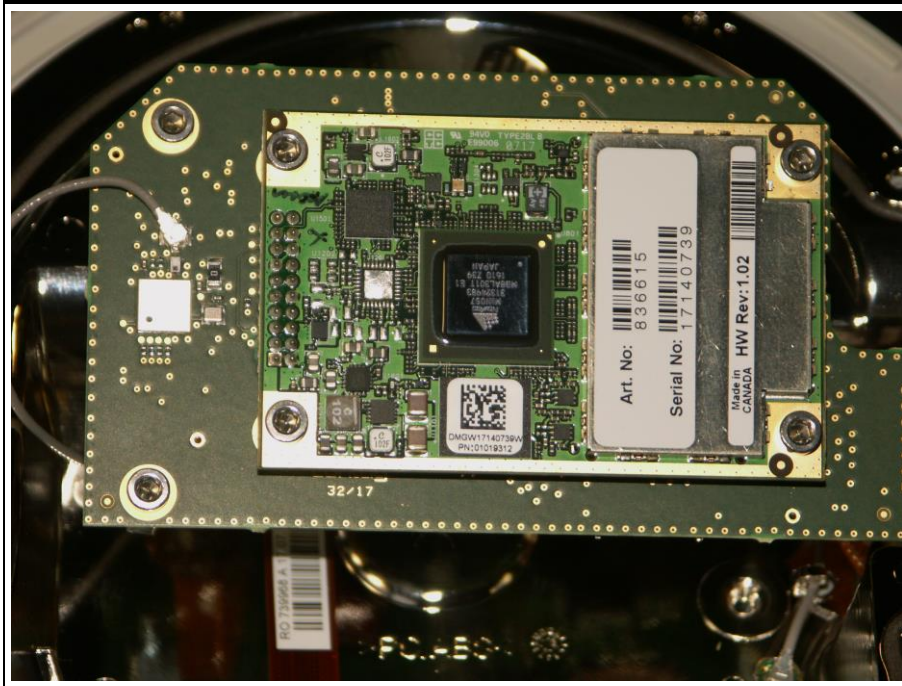

EUT INTERIOR

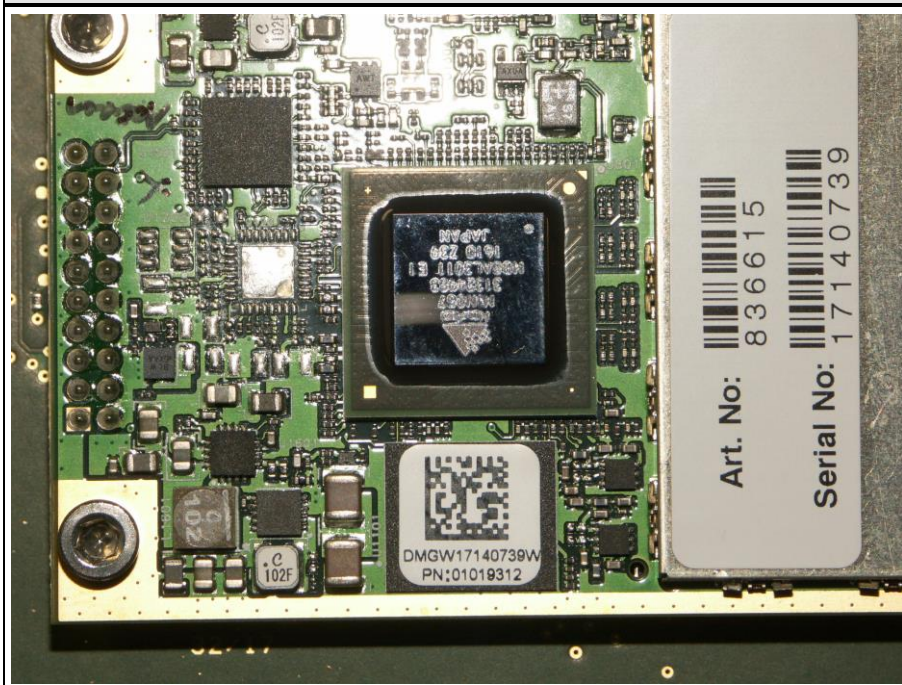

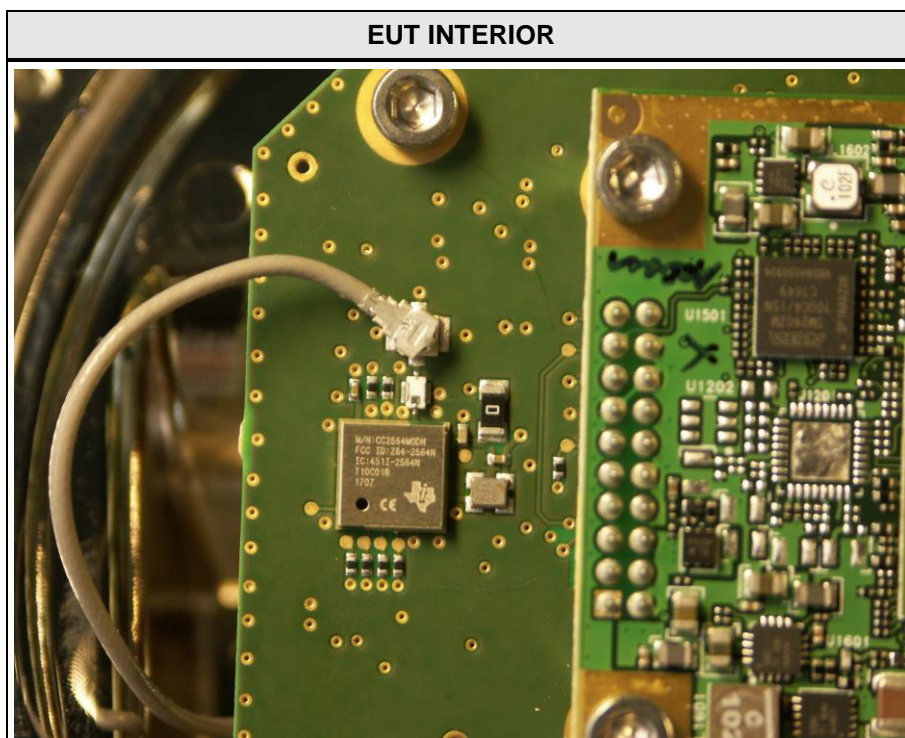
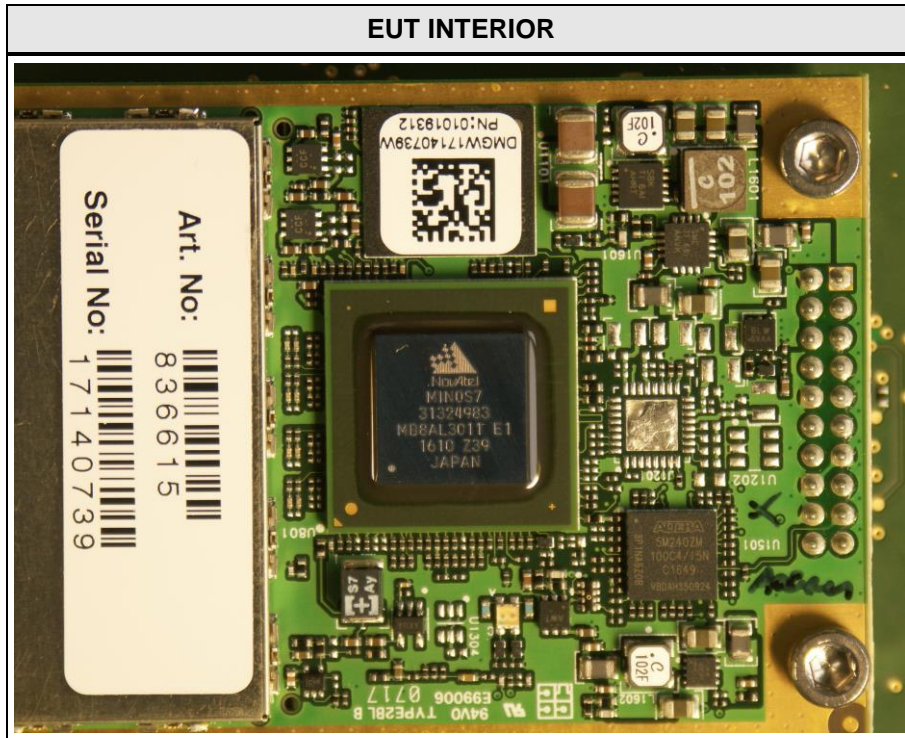

1.3 Photos – Test Setup

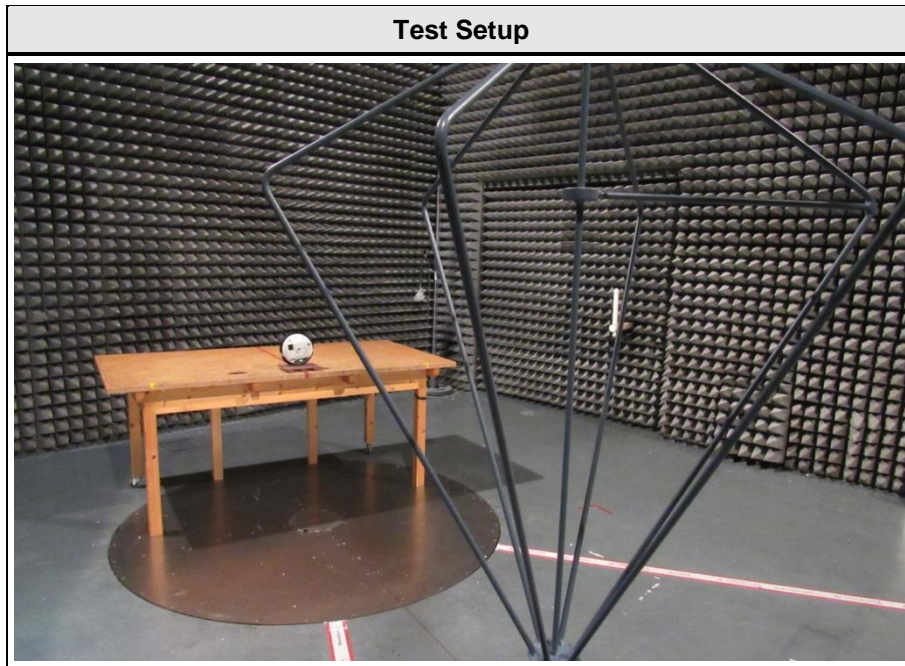

1.4 Support Equipment

Product Type	Device	Manufacturer	Model	Comment
SIM	Communication Tester	R&S	CBT	Used for signaling
Description:				
AE	Auxillary Equipment			
SIM	Simulator			
CBL	Connecting Cable			
Comment:				

1.5 Test Modes

Mode	Description
DH5 Single	Mode = Transmit Modulation = GFSK Spreading = None Packet type = DH5 Duty cycle = 78%
2-DH5 Single	Mode = Transmit Modulation = PI/4-DQPSK Spreading = None Packet type = 2-DH5 Duty cycle = 78%
3-DH5 Single	Mode = Transmit Modulation = 8-DPSK Spreading = None Packet type = 3-DH5 Duty cycle = 78%
Receive	Mode = Receive
Comment:	

1.6 Test Frequencies

Designator	Mode	Channel	Frequency [MHz]
F1	Tx / Rx	0	2402
F2	Tx / Rx	39	2441
F4	Tx / Rx	78	2480

1.7 Sample emission level calculation

The following is a description of terms and a sample calculation, as appears in the radiated emissions data table. The numbers used in the calculation are for example only. There is no direct correlation to the specific data taken for the product described in this document:

Reading:

This is the reading obtained on the spectrum analyzer in dBµV. Any external preamplifiers used are taken into account through internal analyzer settings.

A.F.:

This is the antenna factor for the receiving antenna. It is a conversion factor, which converts electric fields strengths to voltages, which can be measured directly on the spectrum analyzer. It is treated as a loss in dB. Cable losses have been included with the A.F. to simplify the calculations. The antenna factor is used in calculations as follows:

$$\text{Reading on Analyzer (dB}\mu\text{V)} + \text{A.F. (dB)} = \text{Net field strength (dB}\mu\text{V/m)}$$

Net:

This is the net field strength measurement (as shown above).

Limit:

This is the FCC Class B radiated emission limit (in units of dBµV/m). The FCC limits are given in units of µV/m. The following formula is used to convert the units of µV/m to dBµV/m:

$$\text{Limit (dB}\mu\text{V/m)} = 20 \cdot \log(\mu\text{V/m})$$

Margin:

This is the margin of compliance below the FCC limit. The units are given in dB. A negative margin indicates the emission was below the limit. A positive margin indicates that the emission exceeds the limit.

Example only:

Reading + AF	=	Net Reading	:	Net reading	-	FCC limit	=	Margin
+21.5 dBµV		+ 26 dB = 47.5 dBµV/m		47.5 dBµV/m		- 57.0 dBµV/m		= -9.5 dB

2 Result Summary

FCC 47 CFR Part 15C, ISED RSS-247				
Product Standard Reference	Requirement	Reference Method	Result	Remarks
RSS-Gen 6.6	Occupied Bandwidth	ANSI C63.10	N/R	Informational only
FCC § 15.247(a)(1) ISED RSS-247 § 5.1	20 dB Bandwidth	ANSI C63.10	N/T	
FCC § 15.247(a)(1)(iii) ISED RSS-247 § 5.1	Number of hopping frequencies	ANSI C63.10	N/T	
FCC § 15.247(a)(1) ISED RSS-247 § 5.1	Frequency hopping channel separation	ANSI C63.10	N/T	
FCC § 15.247(a)(1)(iii) ISED RSS-247 § 5.1	Time of occupancy (Dwell time)	ANSI C63.10	N/T	
FCC § 15.247(b)(1) ISED RSS-247 § 5.4	Maximum peak conducted power	ANSI C63.10	N/T	
FCC § 15.207 ISED RSS-247 § 3.1	AC power line conducted emissions	ANSI C63.10	N/T	
FCC § 15.247(d) ISED RSS-247 § 5.5	Band edge compliance	ANSI C63.10	N/T	
FCC § 15.247(d) ISED RSS-247 § 5.5	Conducted spurious emissions	ANSI C63.10	N/T	
FCC § 15.247(d) FCC § 15.209 ISED RSS-GEN § 8.9	Transmitter radiated spurious emissions	ANSI C63.10	PASS	
ISED RSS-247 § 3.1	Receiver radiated spurious emissions	ANSI C63.10	PASS	
Comment:				

Possible Test Case Verdicts	
PASS	Test object does meet the requirements
FAIL	Test object does not meet the requirements
N/T	Required by standard but not tested
N/R	Not required by standard for the test object

3 Test Conditions and Results

3.1 Test Conditions and Results - Occupied bandwidth

3.1.1 Information

Test Information	
Reference	ISED RSS-Gen 6.6
Measurement Method	ANSI C63.10 6.9.3
Operator	Sebastian Suckow
Date	2017-11-07

3.1.2 Limits

Limits
None (Informational only)

3.1.3 Setup

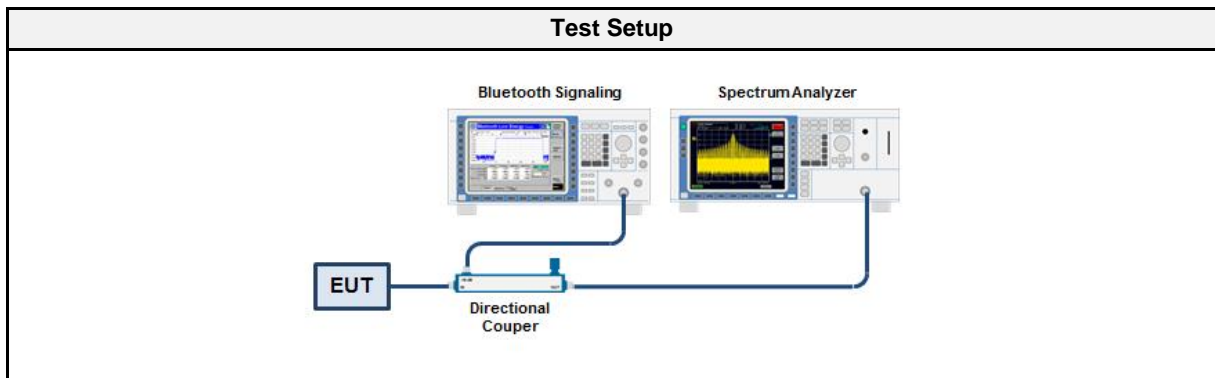

3.1.4 Equipment

Test Equipment					
Description	Manufacturer	Model	Identifier	Cal. Date	Cal. Due
Spectrum Analyzer	R&S	FSU 26	EF01003	2017-07	2018-07

3.1.5 Procedure

Test Procedure
<ol style="list-style-type: none"> 1. EUT transmitter is activated in test mode under normal conditions 2. The spectrum analyzer is set to peak detection and maximum hold with a span twice the emission spectrum 3. The resolution bandwidth is set to 1 % of the bandwidth 4. The occupied bandwidth is measured with the build-in analyzer function

3.1.6 Results

Test Results		
Mode	Frequency [MHz]	Bandwidth [MHz]
DH5	2402	0.865
DH5	2441	0.855
DH5	2480	0.865
2-DH5	2402	1.165
2-DH5	2441	1.145
2-DH5	2480	1.165
3-DH5	2402	1.160
3-DH5	2441	1.140
3-DH5	2480	1.175

Occupied Bandwidth

Project Number: G0M-1707-6725
 Applicant: Leica Geosystems AG
 Model Description: External GNSS Antenna
 Model: GG04 plus
 Test Sample ID: 15123
 Reference Standards: FCC 15.247, RSS-247
 Reference Method: ANSI C63.10:2013, Section 6.9.3
 Operational Mode: DH5, Channel: 0, 2402 MHz
 Operating Conditions: Tnom/Vnom
 Operator: S. Suckow
 Test Site: Eurofins Product Service GmbH
 Test Date: 2017-11-07
 Occupied Bandwidth [MHz]: 0.865

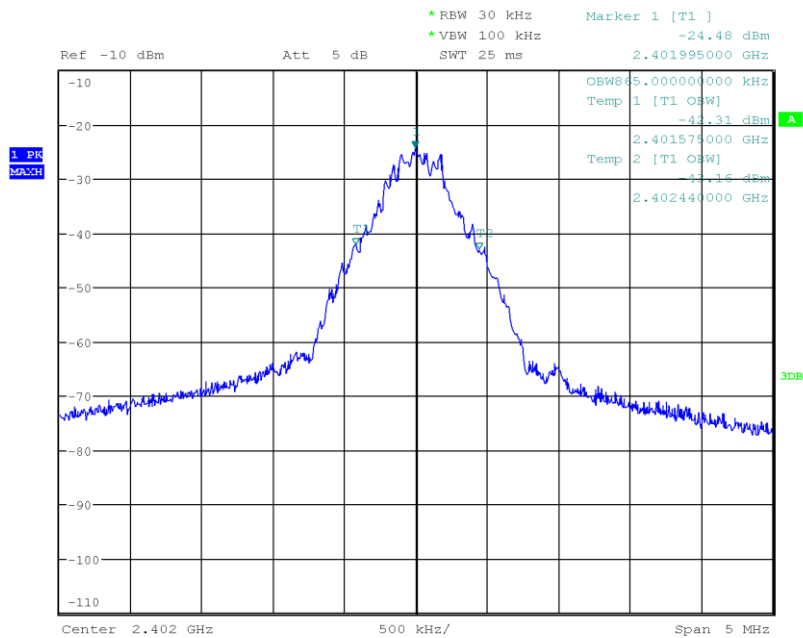

Date: 7.NOV.2017 15:07:50

Occupied Bandwidth

Project Number: G0M-1707-6725
 Applicant: Leica Geosystems AG
 Model Description: External GNSS Antenna
 Model: GG04 plus
 Test Sample ID: 15123
 Reference Standards: FCC 15.247, RSS-247
 Reference Method: ANSI C63.10:2013, Section 6.9.3
 Operational Mode: DH5, Channel: 39, 2441 MHz
 Operating Conditions: Tnom/Vnom
 Operator: S. Suckow
 Test Site: Eurofins Product Service GmbH
 Test Date: 2017-11-07
 Occupied Bandwidth [MHz]: 0.855

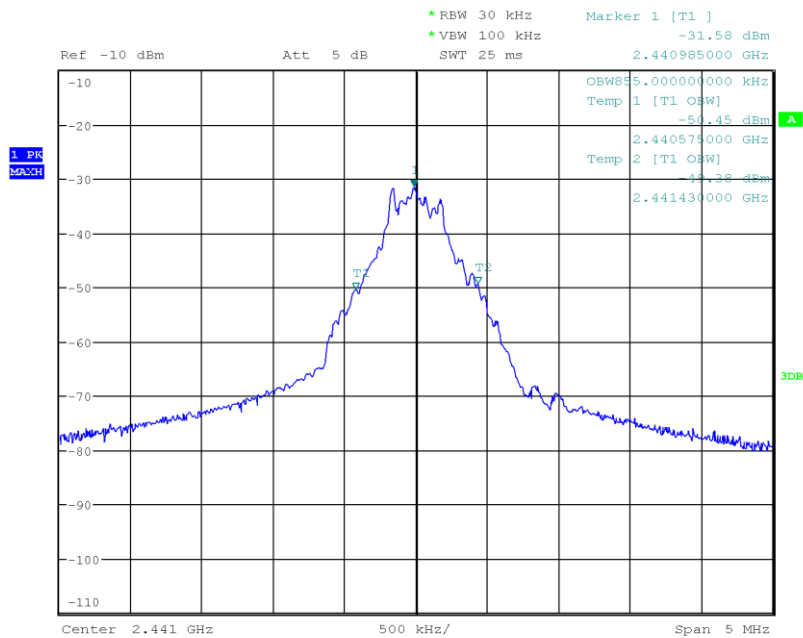

Date: 7.NOV.2017 15:09:41

Occupied Bandwidth

Project Number: G0M-1707-6725
 Applicant: Leica Geosystems AG
 Model Description: External GNSS Antenna
 Model: GG04 plus
 Test Sample ID: 15123
 Reference Standards: FCC 15.247, RSS-247
 Reference Method: ANSI C63.10:2013, Section 6.9.3
 Operational Mode: DH5, Channel: 78, 2480 MHz
 Operating Conditions: Tnom/Vnom
 Operator: S. Suckow
 Test Site: Eurofins Product Service GmbH
 Test Date: 2017-11-07
 Occupied Bandwidth [MHz]: 0.865

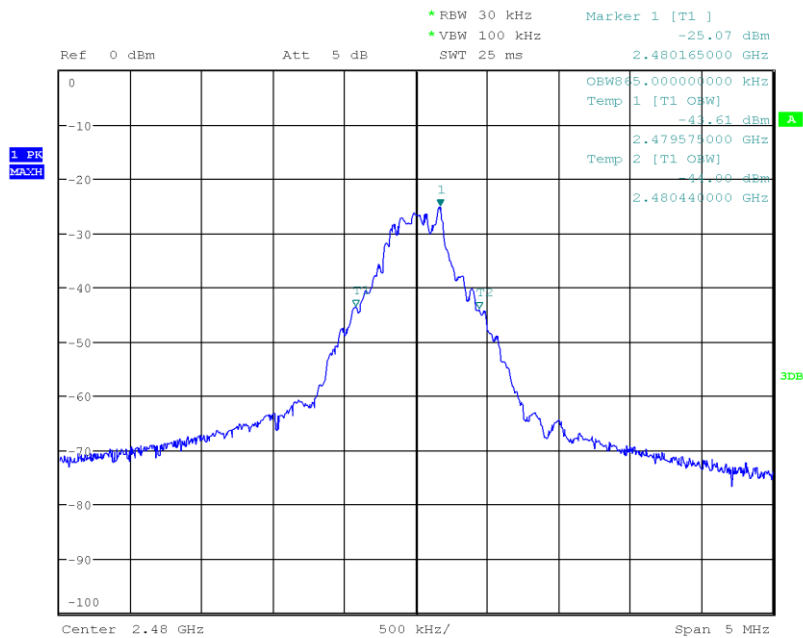

Date: 7.NOV.2017 15:12:35

Occupied Bandwidth

Project Number: G0M-1707-6725
 Applicant: Leica Geosystems AG
 Model Description: External GNSS Antenna
 Model: GG04 plus
 Test Sample ID: 15123
 Reference Standards: FCC 15.247, RSS-247
 Reference Method: ANSI C63.10:2013, Section 6.9.3
 Operational Mode: 2-DH5, Channel: 0, 2402 MHz
 Operating Conditions: Tnom/Vnom
 Operator: S. Suckow
 Test Site: Eurofins Product Service GmbH
 Test Date: 2017-11-07
 Occupied Bandwidth [MHz]: 1.165

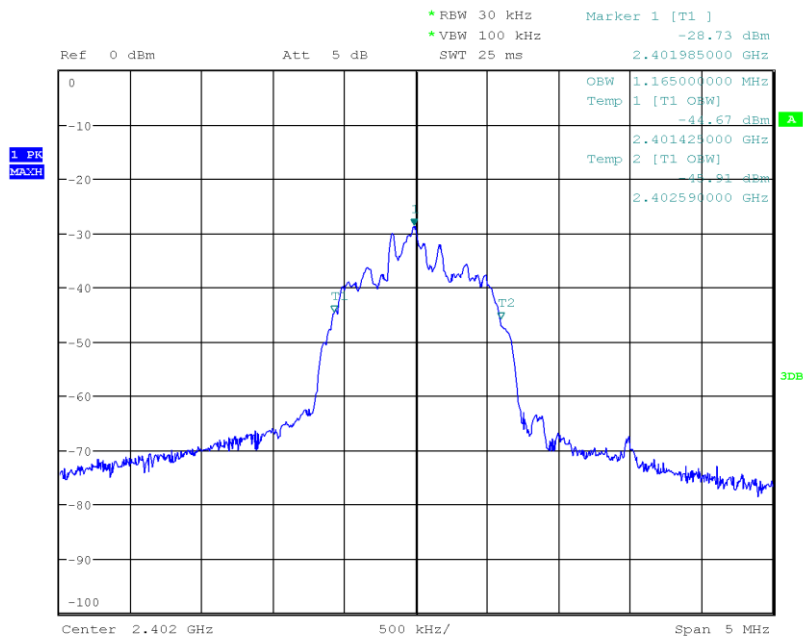

Date: 7.NOV.2017 15:16:30

Occupied Bandwidth

Project Number: G0M-1707-6725
 Applicant: Leica Geosystems AG
 Model Description: External GNSS Antenna
 Model: GG04 plus
 Test Sample ID: 15123
 Reference Standards: FCC 15.247, RSS-247
 Reference Method: ANSI C63.10:2013, Section 6.9.3
 Operational Mode: 2-DH5, Channel: 39, 2441 MHz
 Operating Conditions: Tnom/Vnom
 Operator: S. Suckow
 Test Site: Eurofins Product Service GmbH
 Test Date: 2017-11-07
 Occupied Bandwidth [MHz]: 1.145

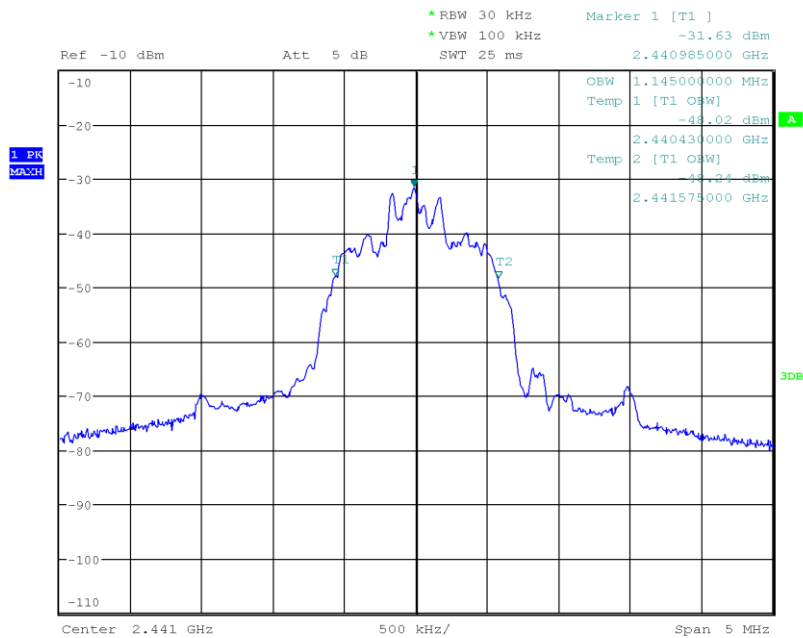

Date: 7.NOV.2017 15:18:22

Occupied Bandwidth

Project Number: G0M-1707-6725
 Applicant: Leica Geosystems AG
 Model Description: External GNSS Antenna
 Model: GG04 plus
 Test Sample ID: 15123
 Reference Standards: FCC 15.247, RSS-247
 Reference Method: ANSI C63.10:2013, Section 6.9.3
 Operational Mode: 2-DH5, Channel: 78, 2480 MHz
 Operating Conditions: Tnom/Vnom
 Operator: S. Suckow
 Test Site: Eurofins Product Service GmbH
 Test Date: 2017-11-07
 Occupied Bandwidth [MHz]: 1.165

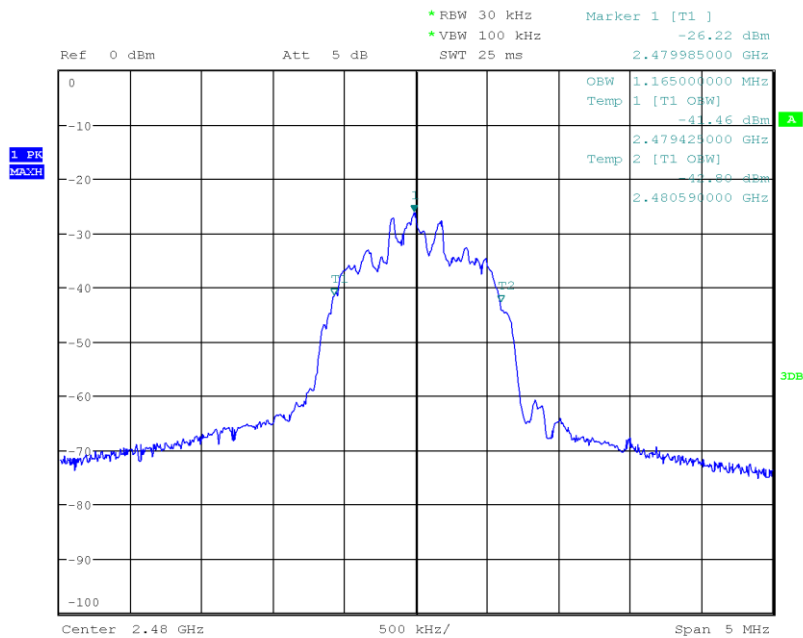

Date: 7.NOV.2017 15:14:35

Occupied Bandwidth

Project Number: G0M-1707-6725
 Applicant: Leica Geosystems AG
 Model Description: External GNSS Antenna
 Model: GG04 plus
 Test Sample ID: 15123
 Reference Standards: FCC 15.247, RSS-247
 Reference Method: ANSI C63.10:2013, Section 6.9.3
 Operational Mode: 3-DH5, Channel: 0, 2402 MHz
 Operating Conditions: Tnom/Vnom
 Operator: S. Suckow
 Test Site: Eurofins Product Service GmbH
 Test Date: 2017-11-07
 Occupied Bandwidth [MHz]: 1.160

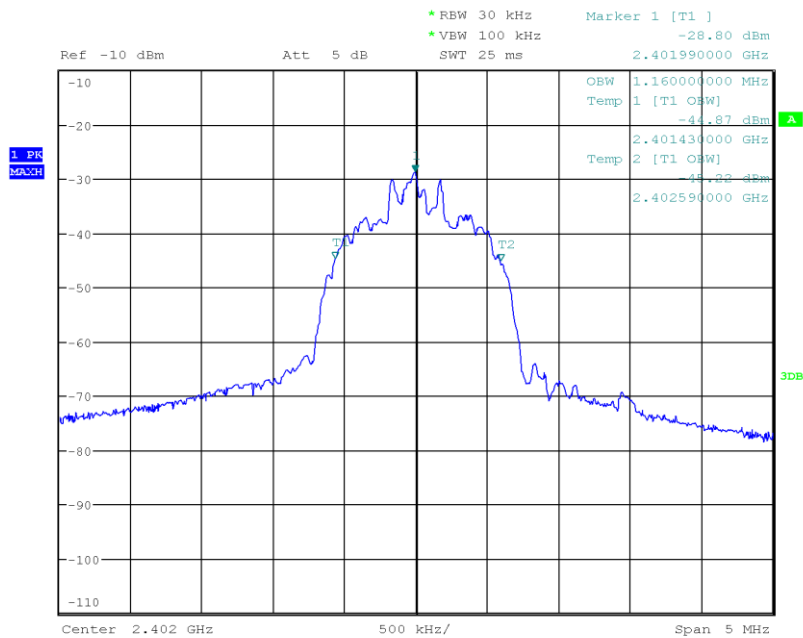

Date: 7.NOV.2017 15:20:30

Occupied Bandwidth

Project Number: G0M-1707-6725
 Applicant: Leica Geosystems AG
 Model Description: External GNSS Antenna
 Model: GG04 plus
 Test Sample ID: 15123
 Reference Standards: FCC 15.247, RSS-247
 Reference Method: ANSI C63.10:2013, Section 6.9.3
 Operational Mode: 3-DH5, Channel: 39, 2441 MHz
 Operating Conditions: Tnom/Vnom
 Operator: S. Suckow
 Test Site: Eurofins Product Service GmbH
 Test Date: 2017-11-07
 Occupied Bandwidth [MHz]: 1.140

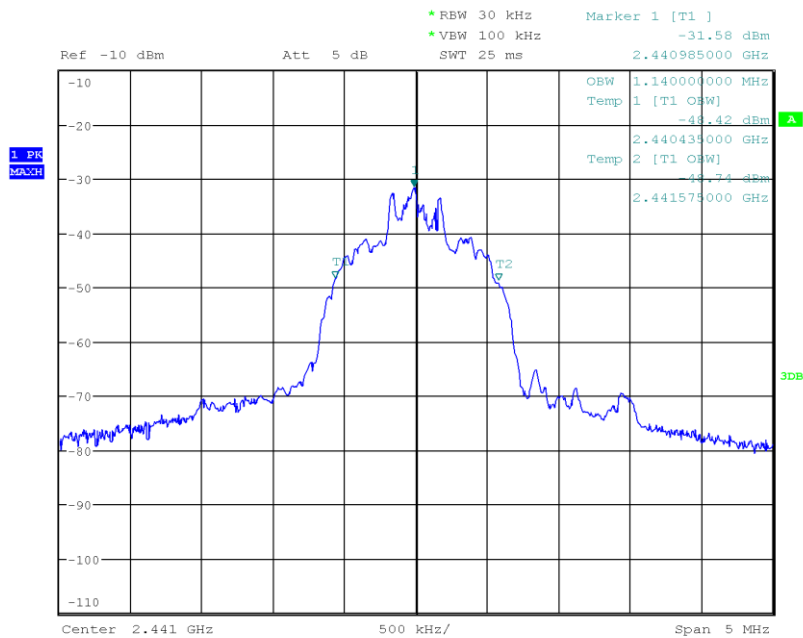

Date: 7.NOV.2017 15:22:38

Occupied Bandwidth

Project Number: G0M-1707-6725
 Applicant: Leica Geosystems AG
 Model Description: External GNSS Antenna
 Model: GG04 plus
 Test Sample ID: 15123
 Reference Standards: FCC 15.247, RSS-247
 Reference Method: ANSI C63.10:2013, Section 6.9.3
 Operational Mode: 3-DH5, Channel: 78, 2480 MHz
 Operating Conditions: Tnom/Vnom
 Operator: S. Suckow
 Test Site: Eurofins Product Service GmbH
 Test Date: 2017-11-07
 Occupied Bandwidth [MHz]: 1.175

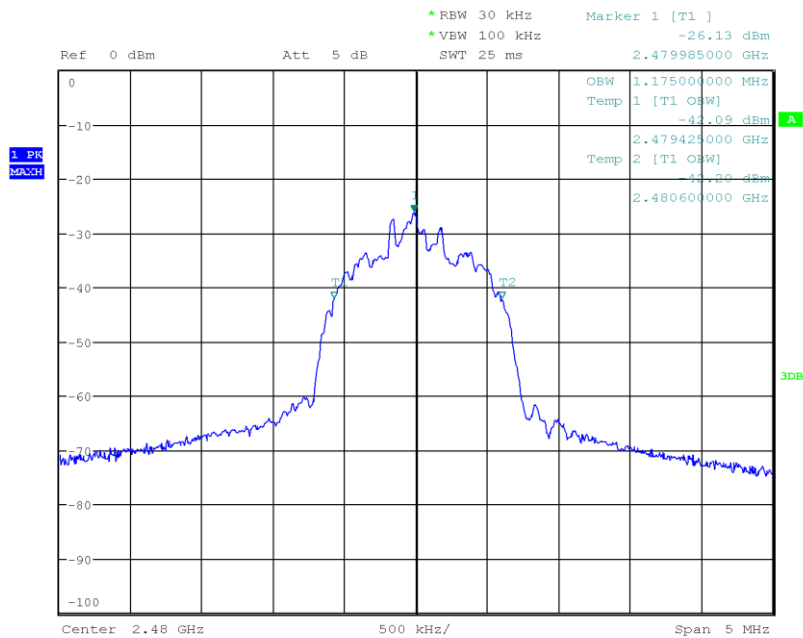

Date: 7.NOV.2017 15:24:32

3.2 Test Conditions and Results - Transmitter radiated emissions

3.2.1 Information

Test Information	
Reference	FCC 15.247(d) / ISED RSS-GEN 8.9
Measurement Method	ANSI C63.10 6.4, 6.5, 6.6
Operator	Sebastian Suckow
Date	2017-10-27 – 2017-10-30

3.2.2 Limits

Limits			
Frequency [MHz]	Detector	Field strength [dB μ V/m]	Measurement distance [m]
0.009 - 0.09	Average	2400/F[kHz]	300
0.09 - 0.110	Quasi-Peak	2400/F[kHz]	300
0.110 - 0.490	Average	2400/F[kHz]	300
0.490 - 1.705	Quasi-Peak	24000/F[kHz]	30
1.705 - 30.0	Quasi-Peak	30	30
30 - 88	Quasi-Peak	100	3
88 - 216	Quasi-Peak	150	3
216 - 960	Quasi-Peak	200	3
960 - 1000	Quasi-Peak	500	3
>1000	Average	500	3

3.2.3 Setup

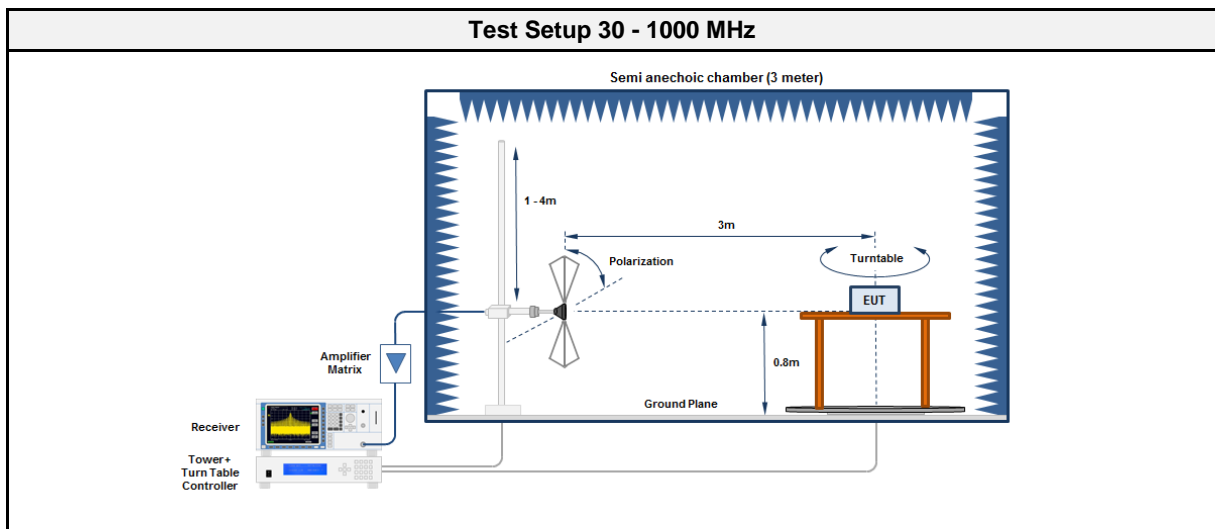

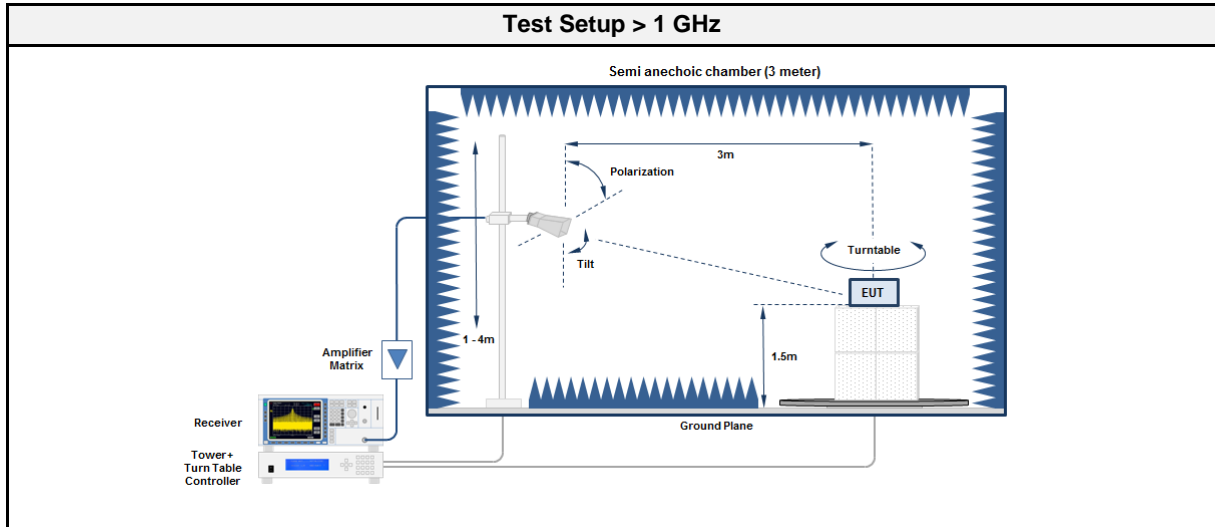

3.2.4 Equipment

Test Equipment 30 - 1000 MHz					
Description	Manufacturer	Model	Identifier	Cal. Date	Cal. Due
Anechoic Chamber	Frankonia	AC1	EF00062	-	-
Measurement Receiver	Agilent	N9038A-526/WXP	EF01070	2017-08	2018-08
Antenna	R&S	HK 116	EF00012	2016-05	2019-05
Antenna	R&S	HL 223	EF00187	2016-05	2019-05

Test Equipment > 1 GHz					
Description	Manufacturer	Model	Identifier	Cal. Date	Cal. Due
Anechoic Chamber	Frankonia	AC1	EF00062	-	-
Measurement Receiver	Agilent	N9038A-526/WXP	EF01070	2017-08	2018-08
Antenna	R&S	BBHA 9120D	EF01153	2017-08	2018-08
Antenna	Amplifier Research	AT4560	EF01152	2017-10	2018-10

3.2.5 Procedure

Test Procedure 30 - 1000 MHz
<ol style="list-style-type: none"> EUT is placed on a non conducting support at the center of a turn table 0.8 m above the ground EUT set to test mode The receiver is set to peak detection with max hold The EUT is rotated through 360° and the height of the antenna is varied from 1 m to 4 m All significant emissions are measured again using the corresponding final detector

Test Procedure > 1 GHz
<ol style="list-style-type: none"> EUT is placed on a non conducting support at the center of a turn table 1.5 m above the ground EUT set to test mode The receiver is set to peak detection with max hold The EUT is rotated through 360° and the height of the antenna is varied from 1 m to 4 m All significant emissions are measured again using the corresponding final detector

3.2.6 Results

Test Results						
Channel [MHz]	Emission [MHz]	Level [dB μ V/m]	Det.	Pol.	Limit [dB μ V/m]	Margin [dB]
2441	2383.2	50.73	pk	hor	74.00	-23.27
2441	4880	43.12	pk	hor	74.00	-30.88
2480	2386	53.33	pk	hor	74.00	-20.67
2480	2483.5	62.92	pk	hor	74.00	-11.08

3.3 Test Conditions and Results - Receiver radiated emissions

3.3.1 Information

Test Information	
Reference	ISED RSS-247 3.1
Measurement Method	ANSI C63.10 6.5, 6.6
Operator	Sebastian Suckow
Date	2017-10-27 – 2017-10-30

3.3.2 Limits

Limits			
Frequency [MHz]	Detector	Field strength [dB μ V/m]	Measurement distance [m]
30 - 88	Quasi-Peak	100	3
88 - 216	Quasi-Peak	150	3
216 - 960	Quasi-Peak	200	3
960 - 1000	Quasi-Peak	500	3
>1000	Average	500	3

3.3.3 Setup

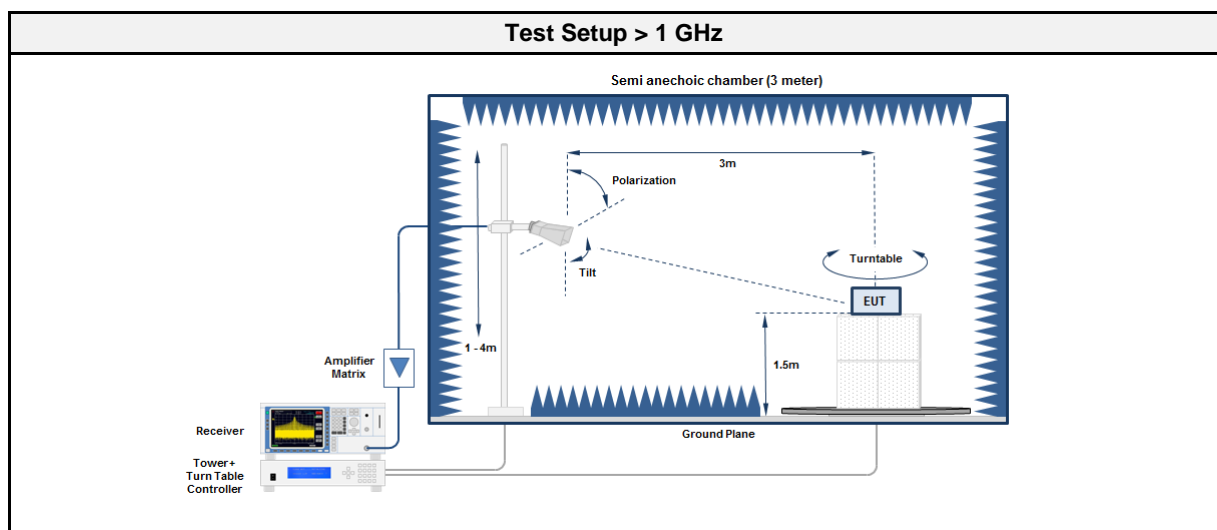
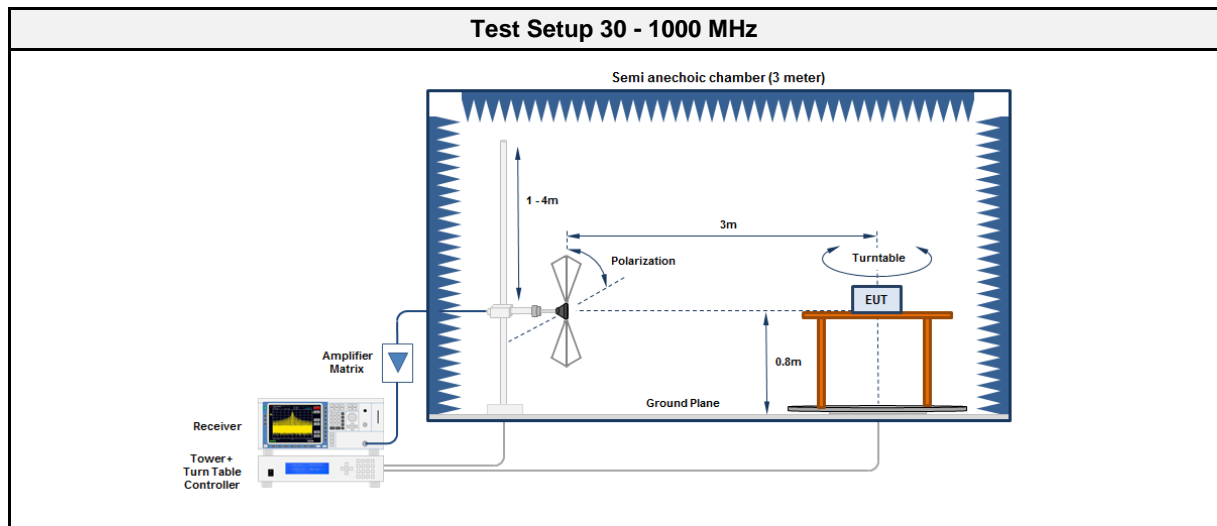

3.3.4 Equipment

Test Equipment 30 - 1000 MHz					
Description	Manufacturer	Model	Identifier	Cal. Date	Cal. Due
Anechoic Chamber	Frankonia	AC1	EF00062	-	-
Measurement Receiver	Agilent	N9038A-526/WXP	EF01070	2017-08	2018-08
Antenna	R&S	HK 116	EF00012	2016-05	2019-05
Antenna	R&S	HL 223	EF00187	2016-05	2019-05

Test Equipment > 1 GHz					
Description	Manufacturer	Model	Identifier	Cal. Date	Cal. Due
Anechoic Chamber	Frankonia	AC1	EF00062	-	-
Measurement Receiver	Agilent	N9038A-526/WXP	EF01070	2017-08	2018-08
Antenna	R&S	BBHA 9120D	EF00018	2016-09	2019-09
Antenna	Amplifier Research	AT4560	EF00302	2017-03	2018-03

3.3.5 Procedure

Test Procedure 30 - 1000 MHz
<ol style="list-style-type: none"> EUT is placed on a non conducting support at the center of a turn table 0.8 m above the ground EUT set to test mode The receiver is set to peak detection with max hold The EUT is rotated through 360° and the height of the antenna is varied from 1 m to 4 m All significant emissions are measured again using the corresponding final detector

Test Procedure > 1 GHz
<ol style="list-style-type: none"> EUT is placed on a non conducting support at the center of a turn table 1.5 m above the ground EUT set to test mode The receiver is set to peak detection with max hold The EUT is rotated through 360° and the height of the antenna is varied from 1 m to 4 m All significant emissions are measured again using the corresponding final detector

3.3.6 Results

Test Results						
Channel [MHz]	Emission [MHz]	Level [dBµV/m]	Det.	Pol.	Limit [dBµV/m]	Margin [dB]
2441	No significant spurious emissions					

ANNEX A Transmitter spurious emissions

Spurious emissions according to FCC 15.247

Project number: G0M-1707-6725

Applicant: Leica Geosystems AG
 EUT Name: External GNSS Antenna
 Model: GG04 plus
 Test Site: Eurofins Product Service GmbH
 Operator: Mr. Suckow
 Test Conditions: Tnom: 22°C, Vnom: 12 VDC
 Antenna: Rohde & Schwarz HK 116, Horizontal
 Measurement distance: 3 m
 Mode: TX; BT 3DH5 2402 MHz
 Test Date: 2017-10-30
 Note:

Index 1

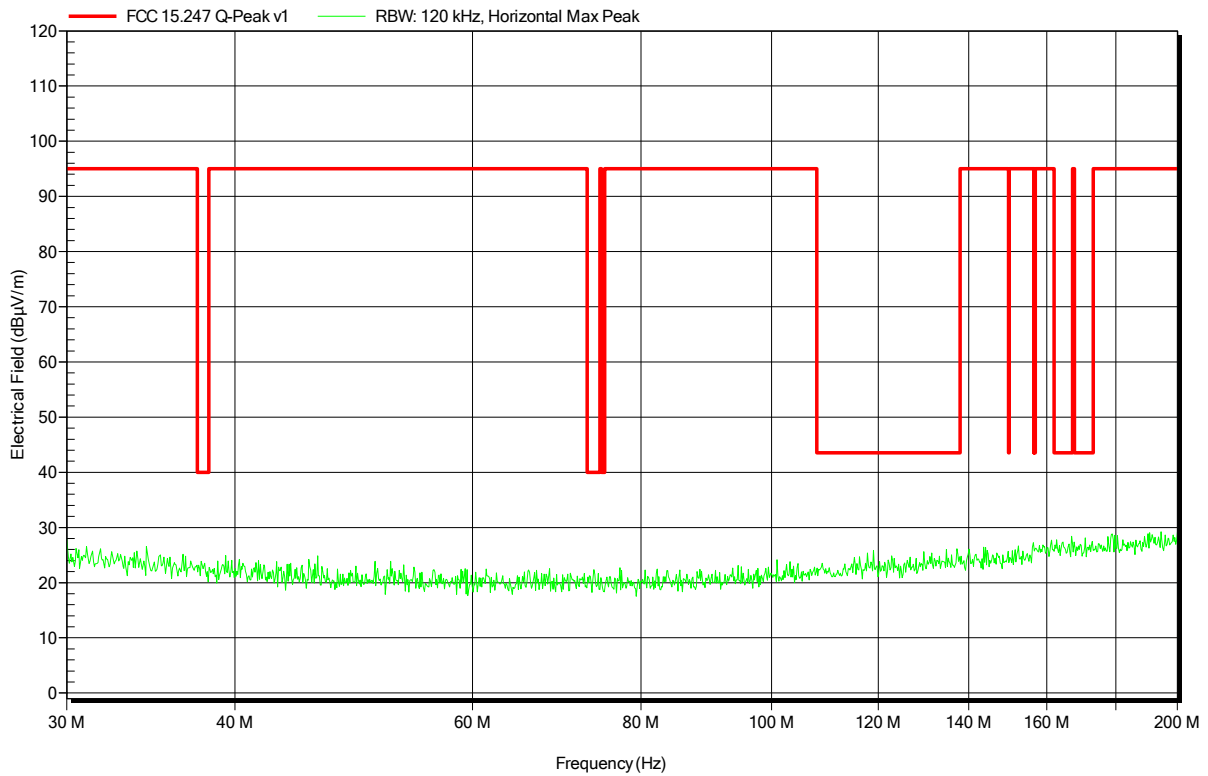

Spurious emissions according to FCC 15.247

Project number: G0M-1707-6725

Applicant: Leica Geosystems AG
 EUT Name: External GNSS Antenna
 Model: GG04 plus
 Test Site: Eurofins Product Service GmbH
 Operator: Mr. Suckow
 Test Conditions: Tnom: 22°C, Vnom: 12 VDC
 Antenna: Rohde & Schwarz HK 116, Vertical
 Measurement distance: 3 m
 Mode: TX; BT 3DH5 2402 MHz
 Test Date: 2017-10-30
 Note:

Index 2

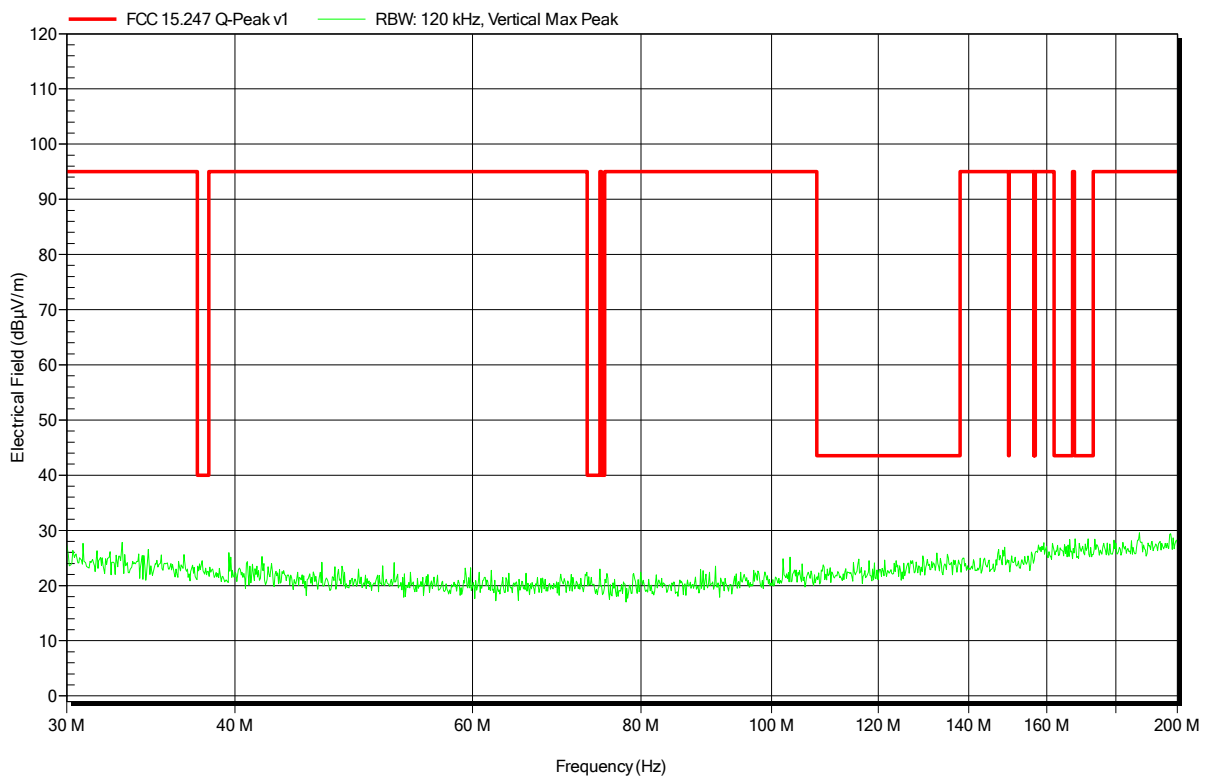

Spurious emissions according to FCC 15.247

Project number: G0M-1707-6725

Applicant: Leica Geosystems AG
 EUT Name: External GNSS Antenna
 Model: GG04 plus
 Test Site: Eurofins Product Service GmbH
 Operator: Mr. Suckow
 Test Conditions: Tnom: 22°C, Vnom: 12 VDC
 Antenna: Rohde & Schwarz HL 223, Horizontal
 Measurement distance: 3 m
 Mode: TX; BT 3DH5 2402 MHz
 Test Date: 2017-10-30
 Note:

Index 11

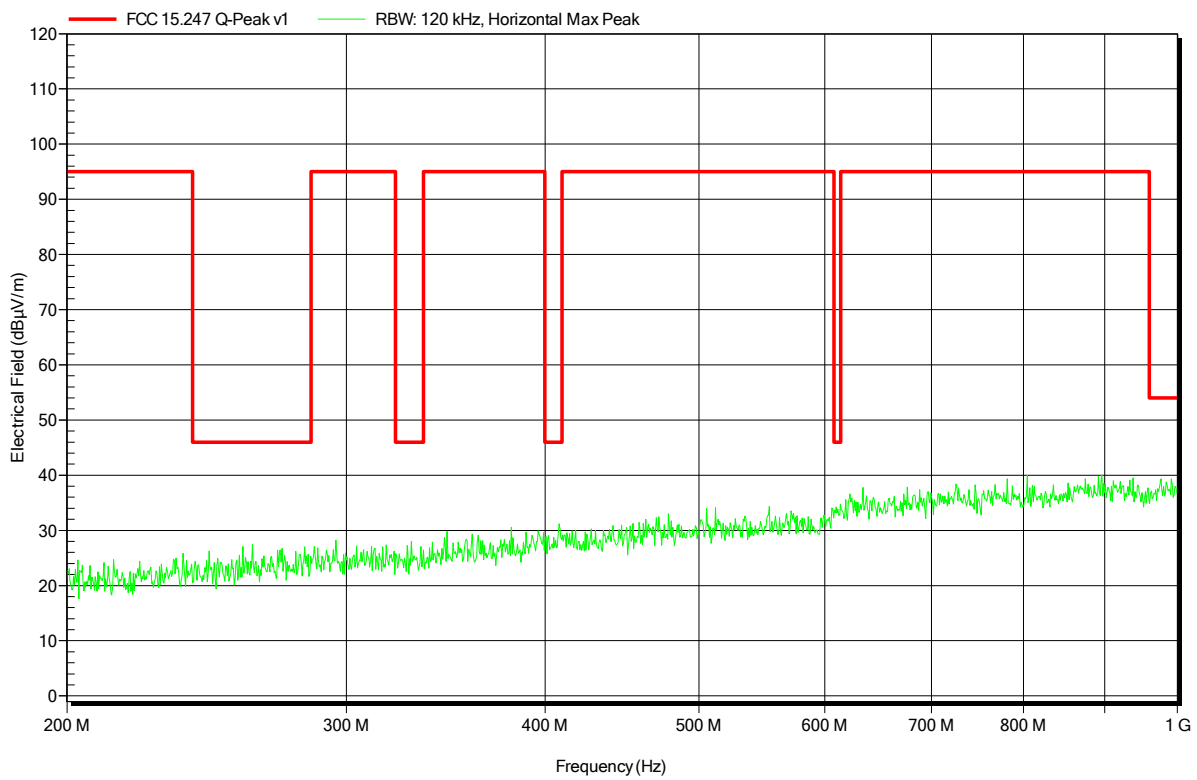

Spurious emissions according to FCC 15.247

Project number: G0M-1707-6725

Applicant: Leica Geosystems AG
 EUT Name: External GNSS Antenna
 Model: GG04 plus
 Test Site: Eurofins Product Service GmbH
 Operator: Mr. Suckow
 Test Conditions: Tnom: 22°C, Vnom: 12 VDC
 Antenna: Rohde & Schwarz HL 223, Vertical
 Measurement distance: 3 m
 Mode: TX; BT 3DH5 2402 MHz
 Test Date: 2017-10-30
 Note:

Index 12

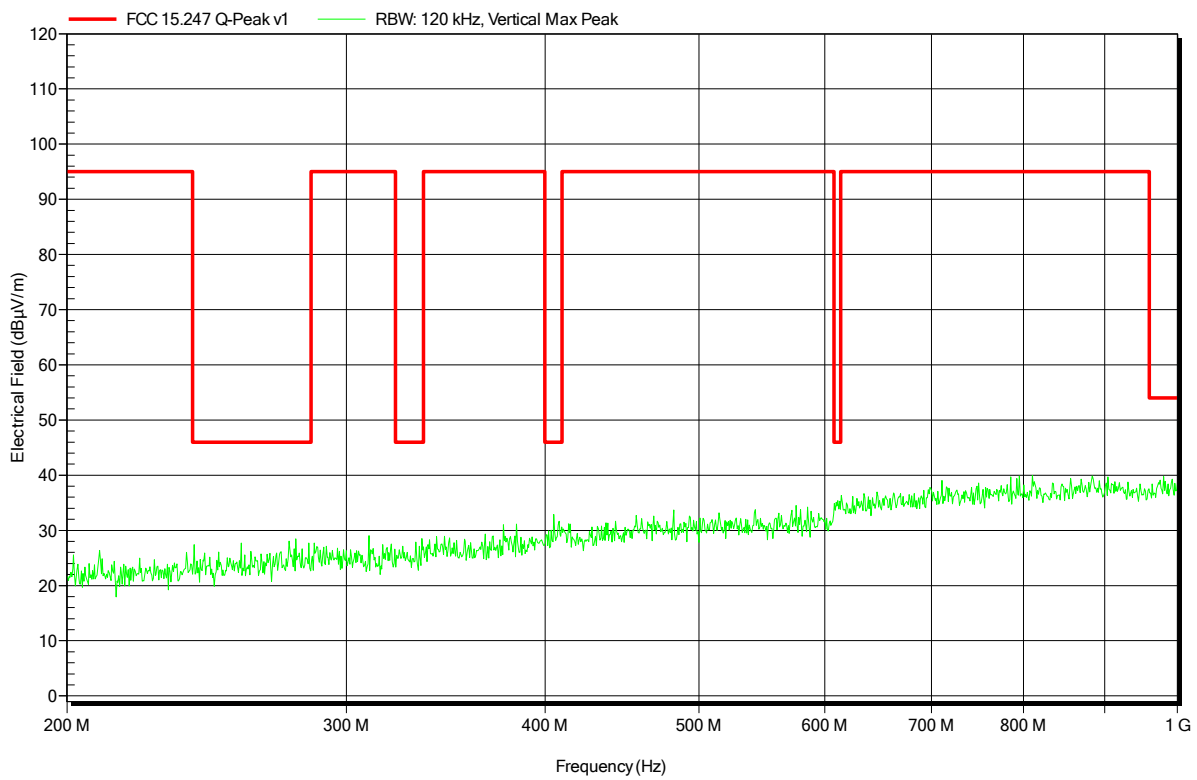

Spurious emissions according to FCC 15.247

Project number: G0M-1707-6725

Applicant: Leica Geosystems AG
 EUT Name: External GNSS Antenna
 Model: GG04 plus
 Test Site: Eurofins Product Service GmbH
 Operator: Sebastian Suckow
 Test Conditions: Tnom: 23°C, Vnom: 12 VDC
 Antenna: Schwarzbeck BBHA 9120D, Horizontal
 Measurement distance: 1 m converted to 3m
 Mode: TX; BT 3DH5 2402 MHz
 Test Date: 2017-10-27
 Note:

Index 9

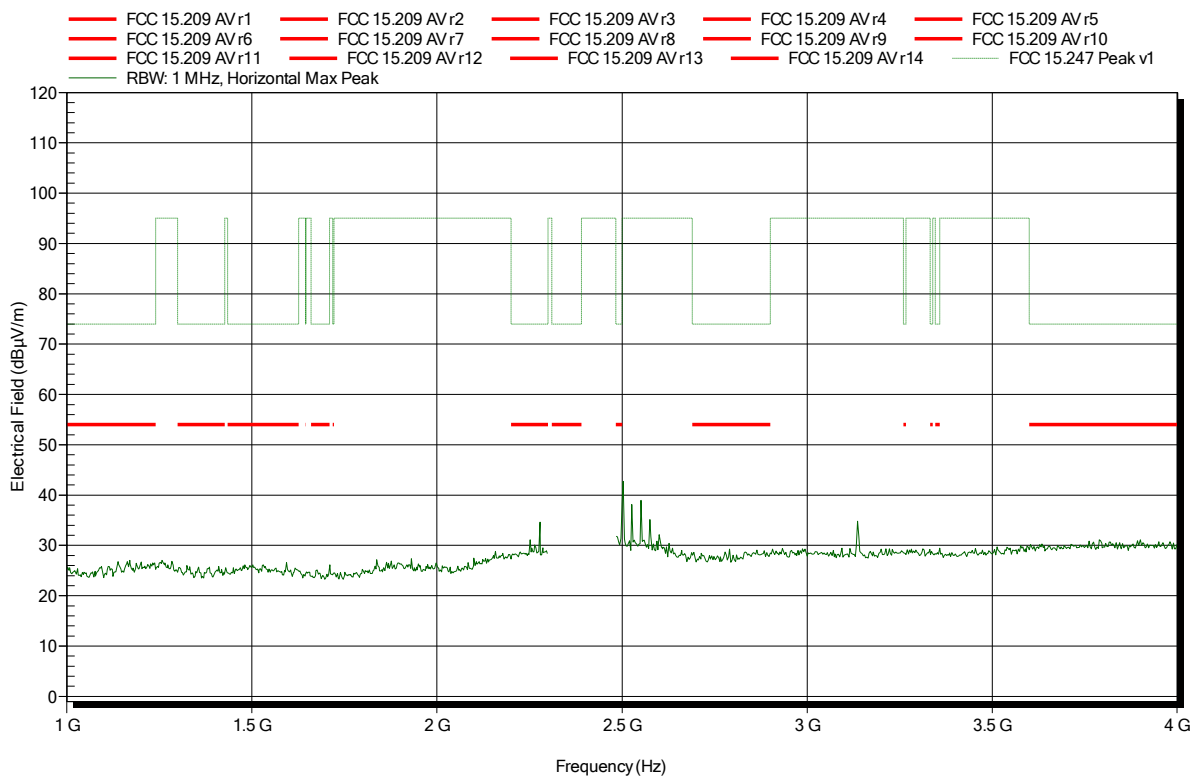

Spurious emissions according to FCC 15.247

Project number: G0M-1707-6725

Applicant: Leica Geosystems AG
 EUT Name: External GNSS Antenna
 Model: GG04 plus
 Test Site: Eurofins Product Service GmbH
 Operator: Sebastian Suckow
 Test Conditions: Tnom: 23°C, Vnom: 12 VDC
 Antenna: Schwarzbeck BBHA 9120D, Vertical
 Measurement distance: 1 m converted to 3m
 Mode: TX; BT 3DH5 2402 MHz
 Test Date: 2017-10-27
 Note:

Index 20

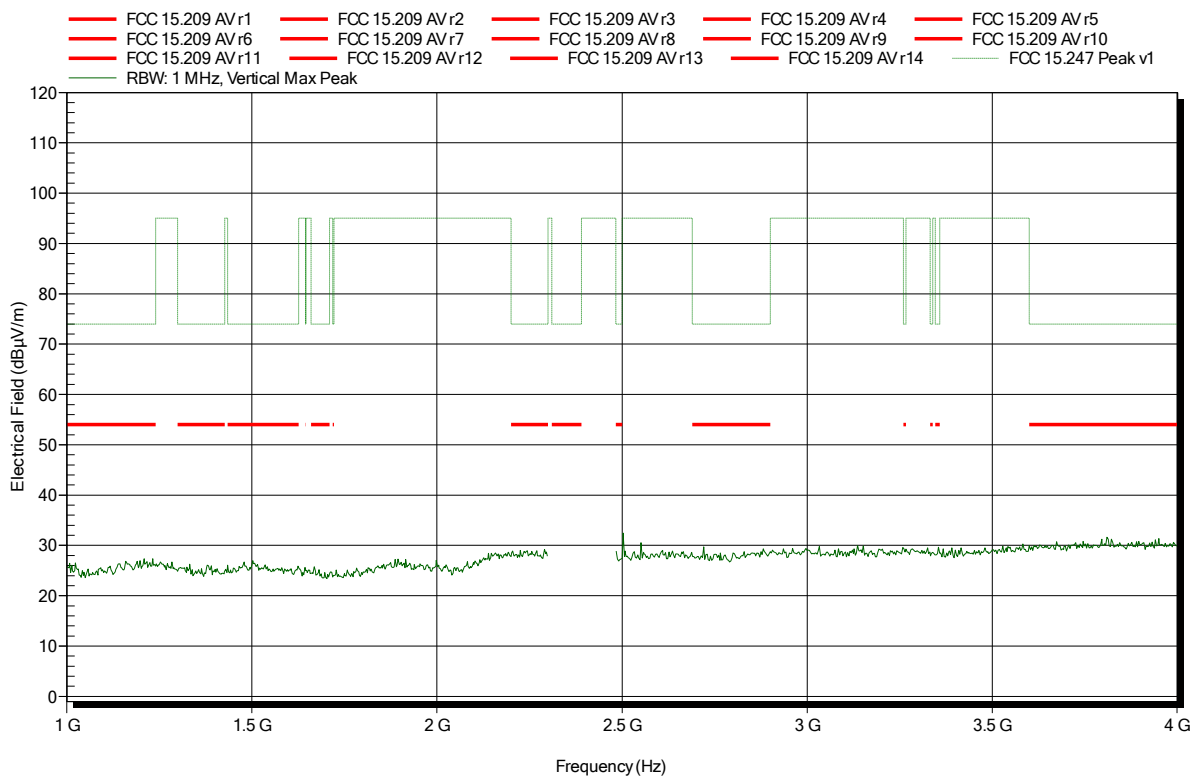

Spurious emissions according to FCC 15.247

Project number: G0M-1707-6725

Applicant: Leica Geosystems AG
 EUT Name: External GNSS Antenna
 Model: GG04 plus
 Test Site: Eurofins Product Service GmbH
 Operator: Sebastian Suckow
 Test Conditions: Tnom: 23°C, Vnom: 12 VDC
 Antenna: Schwarzbeck BBHA 9120D, Horizontal
 Measurement distance: 1 m converted to 3m
 Mode: TX; BT 3DH5 2402 MHz
 Test Date: 2017-10-27
 Note: lower bandedge

Index 17

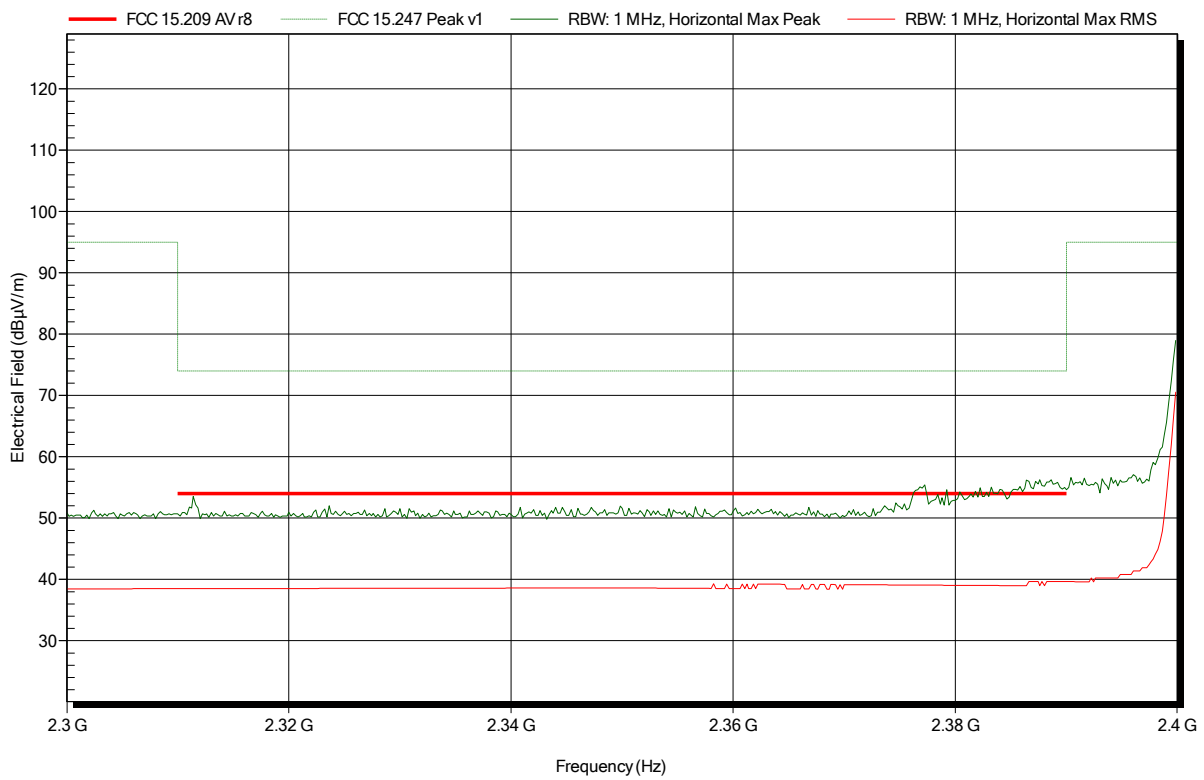

Spurious emissions according to FCC 15.247

Project number: G0M-1707-6725

Applicant: Leica Geosystems AG
 EUT Name: External GNSS Antenna
 Model: GG04 plus
 Test Site: Eurofins Product Service GmbH
 Operator: Sebastian Suckow
 Test Conditions: Tnom: 23°C, Vnom: 12 VDC
 Antenna: Schwarzbeck BBHA 9120D, Vertical
 Measurement distance: 1 m converted to 3m
 Mode: TX; BT 3DH5 2402 MHz
 Test Date: 2017-10-27
 Note: lower bandedge

Index 19

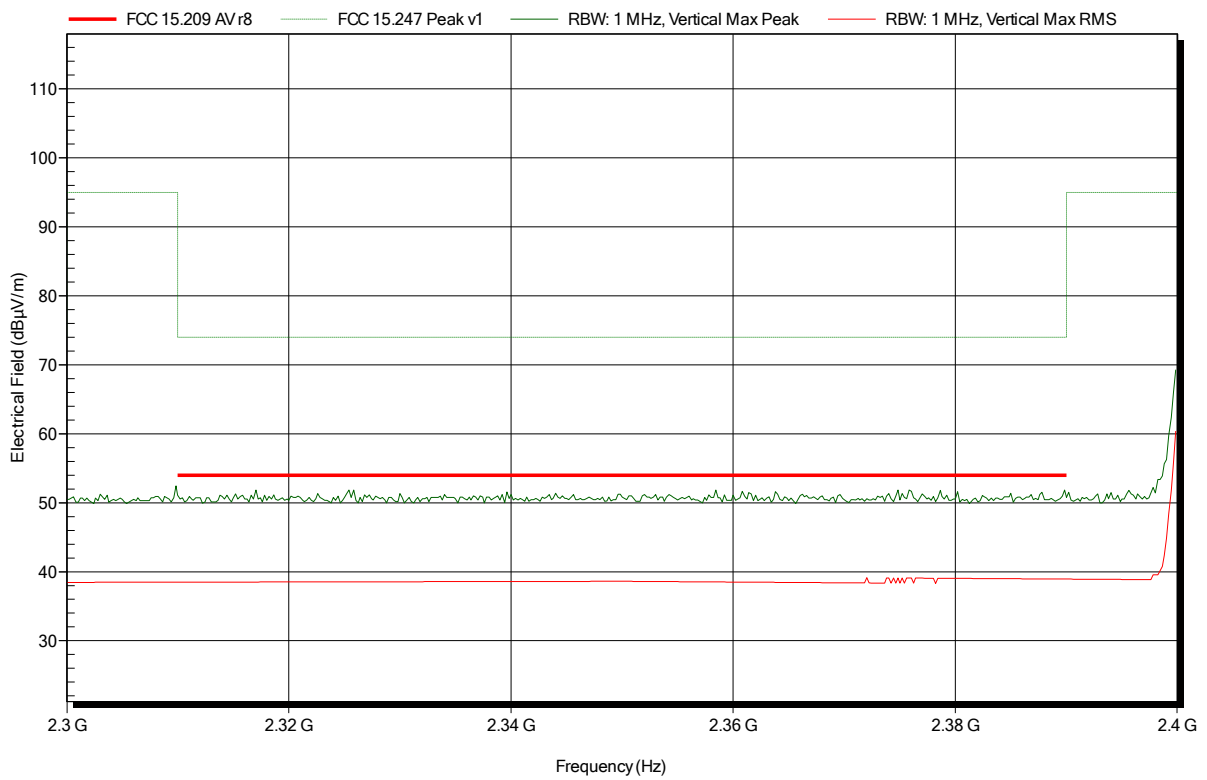

Spurious emissions according to FCC 15.247

Project number: G0M-1707-6725

Applicant: Leica Geosystems AG
 EUT Name: External GNSS Antenna
 Model: GG04 plus
 Test Site: Eurofins Product Service GmbH
 Operator: Sebastian Suckow
 Test Conditions: Tnom: 23°C, Vnom: 12 VDC
 Antenna: Schwarzbeck BBHA 9120D, Horizontal
 Measurement distance: 1 m converted to 3m
 Mode: TX; BT 3DH5 2402 MHz
 Test Date: 2017-10-27
 Note:

Index 8

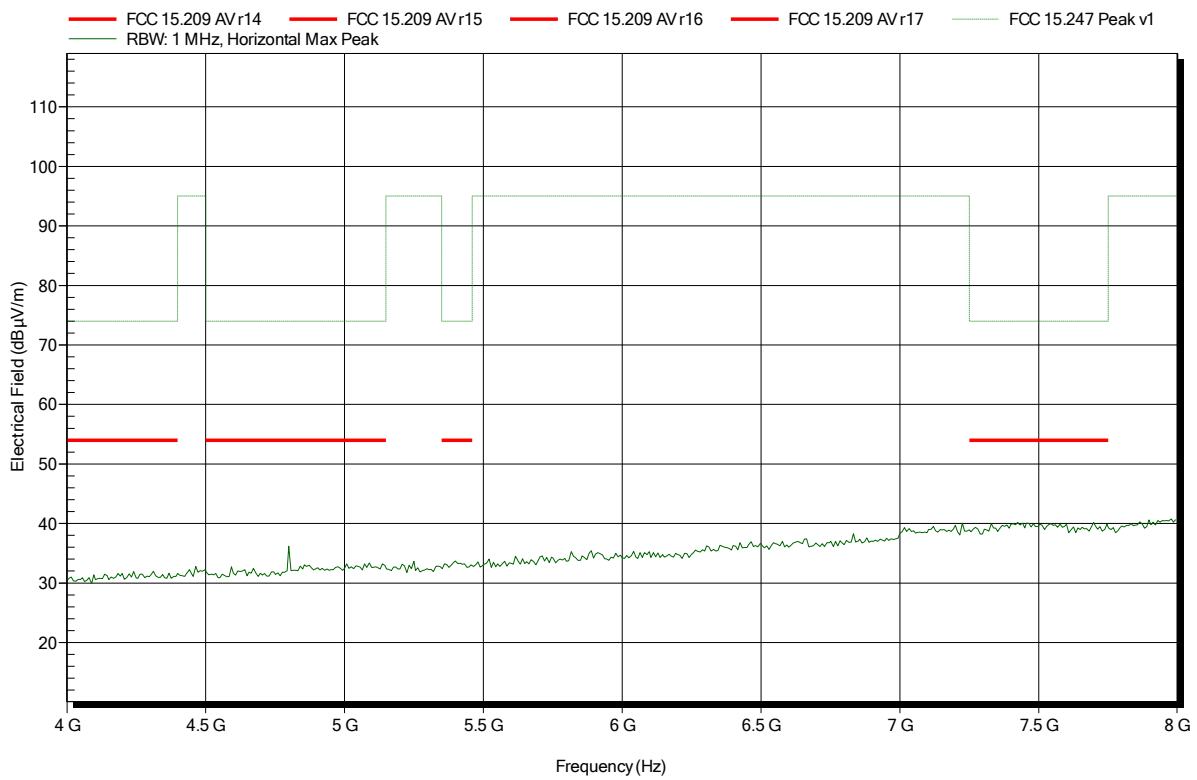

Spurious emissions according to FCC 15.247

Project number: G0M-1707-6725

Applicant: Leica Geosystems AG
 EUT Name: External GNSS Antenna
 Model: GG04 plus
 Test Site: Eurofins Product Service GmbH
 Operator: Sebastian Suckow
 Test Conditions: Tnom: 23°C, Vnom: 12 VDC
 Antenna: Schwarzbeck BBHA 9120D, Vertical
 Measurement distance: 1 m converted to 3m
 Mode: TX; BT 3DH5 2402 MHz
 Test Date: 2017-10-27
 Note:

Index 21

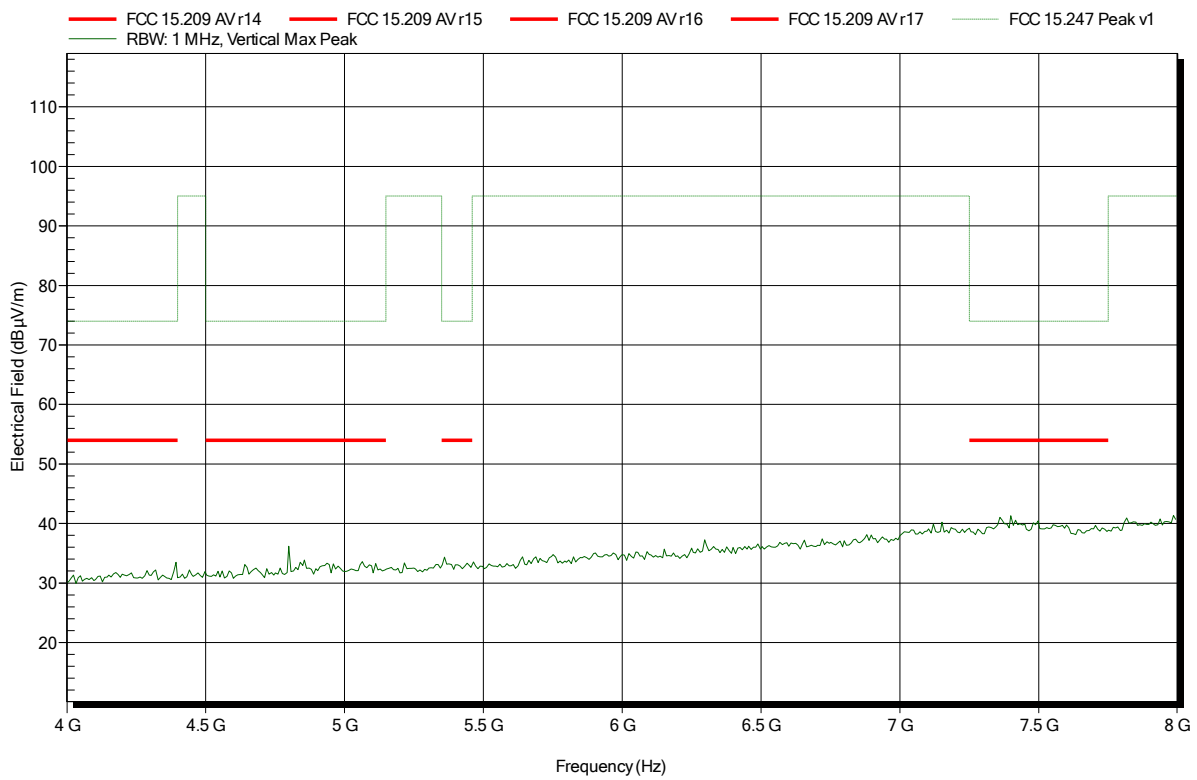

Spurious emissions according to FCC 15.247

Project number: G0M-1707-6725

Applicant: Leica Geosystems AG
 EUT Name: External GNSS Antenna
 Model: GG04 plus
 Test Site: Eurofins Product Service GmbH
 Operator: Sebastian Suckow
 Test Conditions: Tnom: 23°C, Vnom: 12 VDC
 Antenna: Schwarzbeck BBHA 9120D, Horizontal
 Measurement distance: 1 m converted to 3m
 Mode: TX; BT 3DH5 2402 MHz
 Test Date: 2017-10-27
 Note:

Index 7

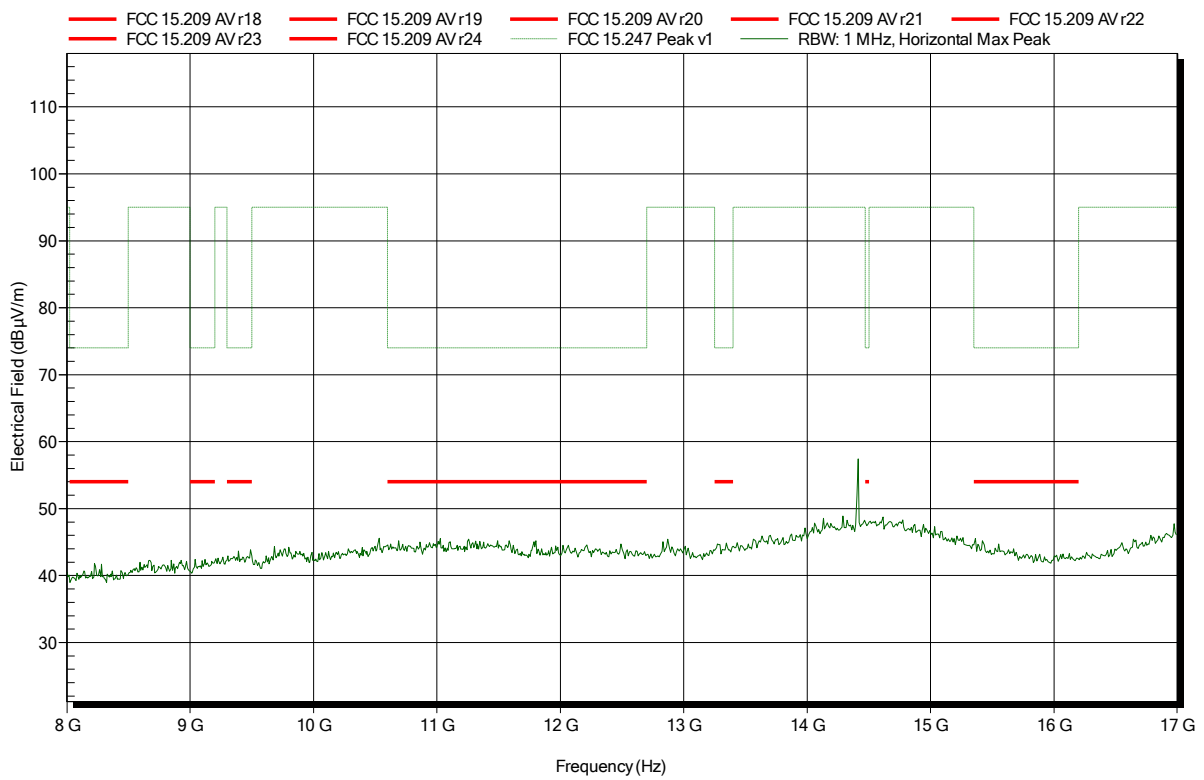

Spurious emissions according to FCC 15.247

Project number: G0M-1707-6725

Applicant: Leica Geosystems AG
 EUT Name: External GNSS Antenna
 Model: GG04 plus
 Test Site: Eurofins Product Service GmbH
 Operator: Sebastian Suckow
 Test Conditions: Tnom: 23°C, Vnom: 12 VDC
 Antenna: Schwarzbeck BBHA 9120D, Vertical
 Measurement distance: 1 m converted to 3m
 Mode: TX; BT 3DH5 2402 MHz
 Test Date: 2017-10-27
 Note:

Index 22

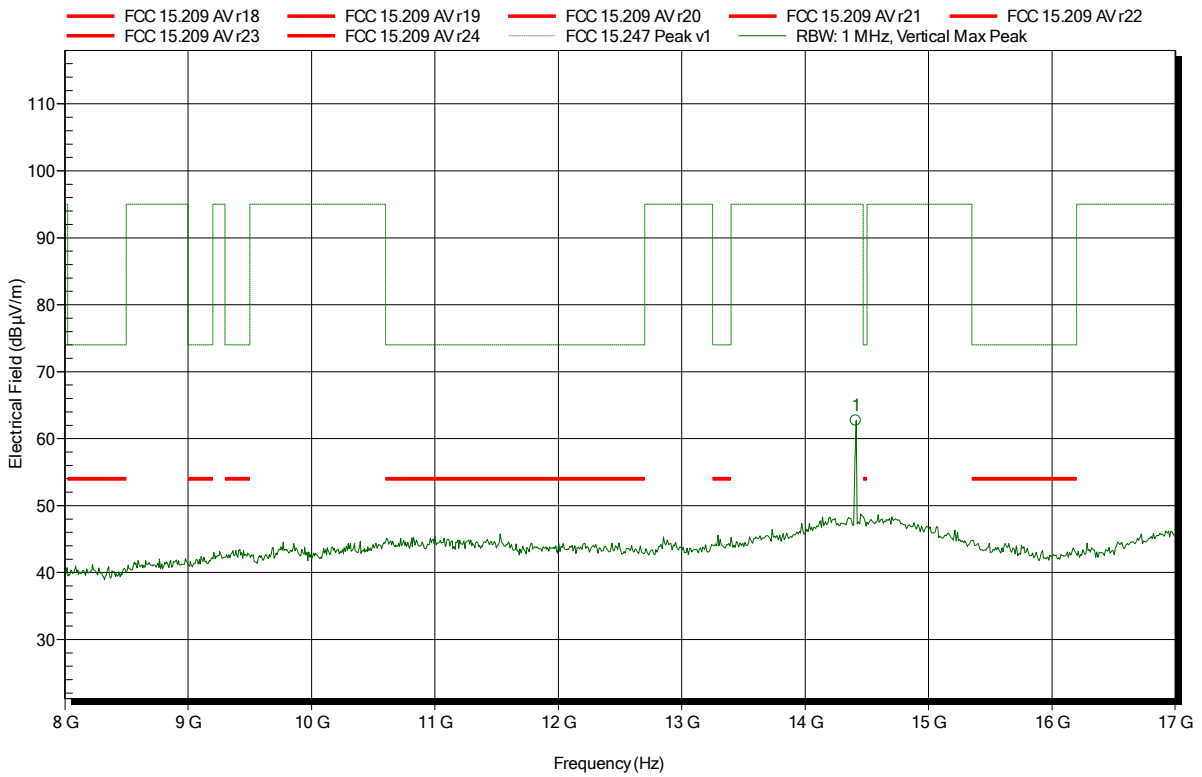

Frequency	Peak	Peak Limit	Peak Difference	Peak Status
14.41 GHz	62.69 dBµV/m	95 dBµV/m	-32.31 dB	Pass

Spurious emissions according to FCC 15.247

Project number: G0M-1707-6725

Applicant: Leica Geosystems AG
 EUT Name: External GNSS Antenna
 Model: GG04 plus
 Test Site: Eurofins Product Service GmbH
 Operator: Sebastian Suckow
 Test Conditions: Tnom: 23°C, Vnom: 12 VDC
 Antenna: Amplifier Research AT 4560, Horizontal
 Measurement distance: 1 m converted to 3m
 Mode: TX; BT 3DH5 2402 MHz
 Test Date: 2017-10-27
 Note:

Index 6

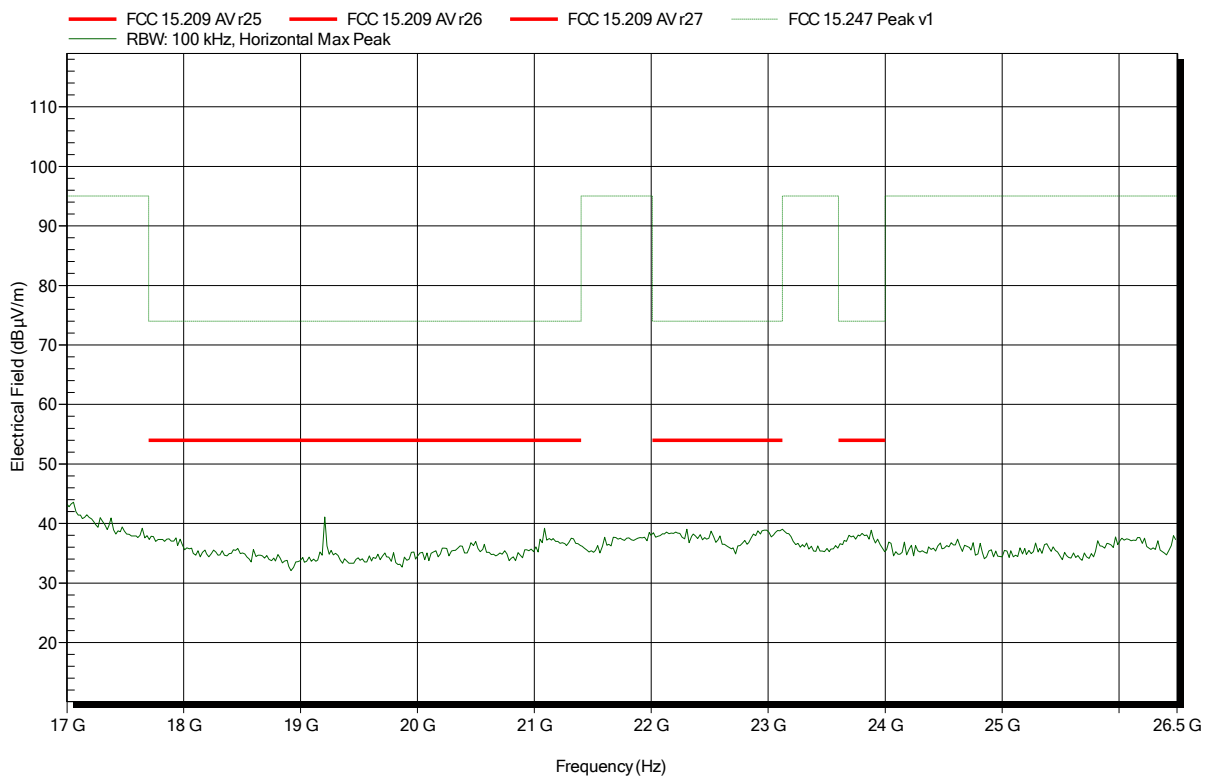

Spurious emissions according to FCC 15.247

Project number: G0M-1707-6725

Applicant: Leica Geosystems AG
 EUT Name: External GNSS Antenna
 Model: GG04 plus
 Test Site: Eurofins Product Service GmbH
 Operator: Sebastian Suckow
 Test Conditions: Tnom: 23°C, Vnom: 12 VDC
 Antenna: Amplifier Research AT 4560, Vertical
 Measurement distance: 1 m converted to 3m
 Mode: TX; BT 3DH5 2402 MHz
 Test Date: 2017-10-27
 Note:

Index 1

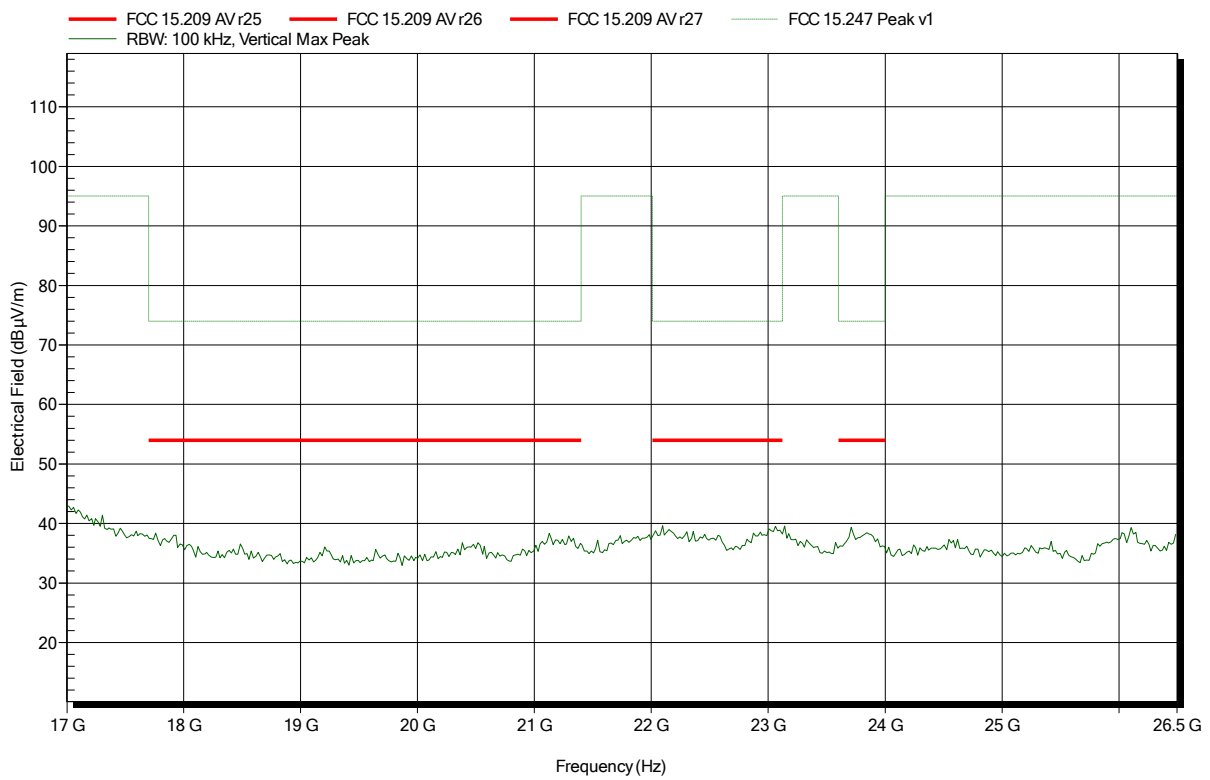

Spurious emissions according to FCC 15.247

Project number: G0M-1707-6725

Applicant: Leica Geosystems AG
 EUT Name: External GNSS Antenna
 Model: GG04 plus
 Test Site: Eurofins Product Service GmbH
 Operator: Mr. Suckow
 Test Conditions: Tnom: 22°C, Vnom: 12 VDC
 Antenna: Rohde & Schwarz HK 116, Horizontal
 Measurement distance: 3 m
 Mode: TX; BT 3DH5 2441 MHz
 Test Date: 2017-10-30
 Note:

Index 4

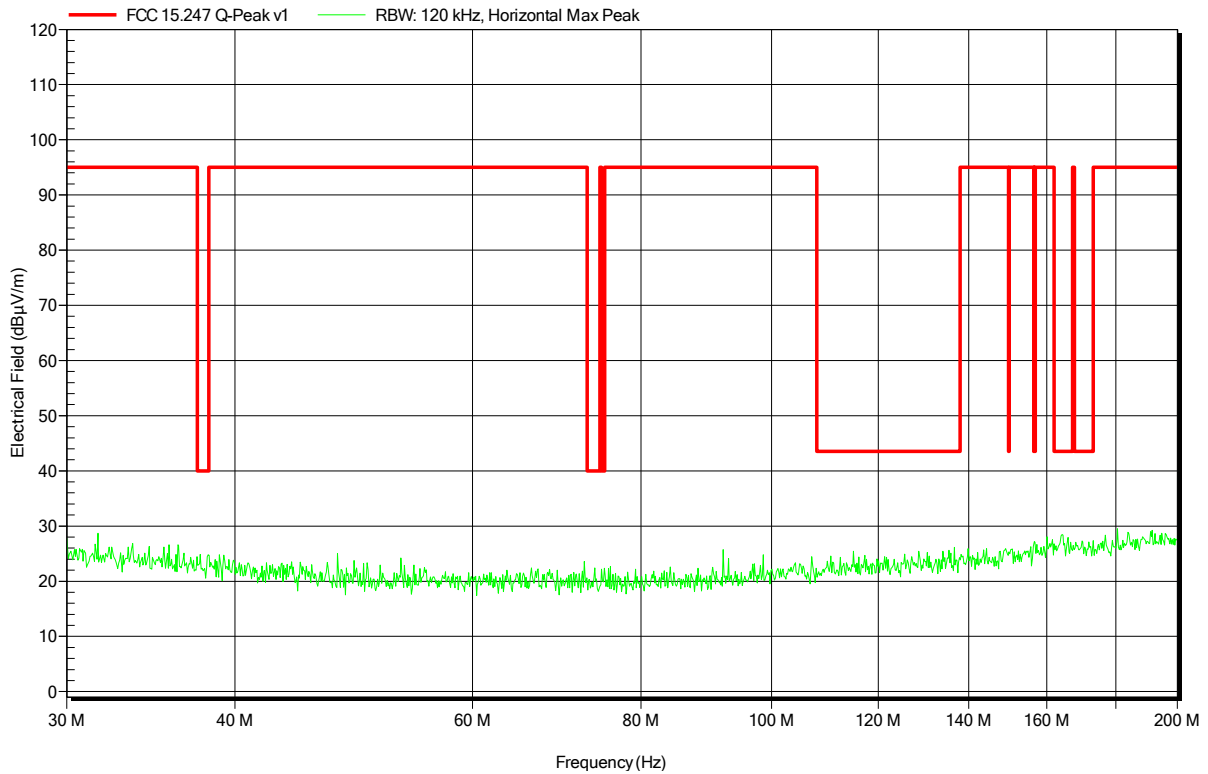

Spurious emissions according to FCC 15.247

Project number: G0M-1707-6725

Applicant: Leica Geosystems AG
 EUT Name: External GNSS Antenna
 Model: GG04 plus
 Test Site: Eurofins Product Service GmbH
 Operator: Mr. Suckow
 Test Conditions: Tnom: 22°C, Vnom: 12 VDC
 Antenna: Rohde & Schwarz HK 116, Vertical
 Measurement distance: 3 m
 Mode: TX; BT 3DH5 2441 MHz
 Test Date: 2017-10-30
 Note:

Index 3

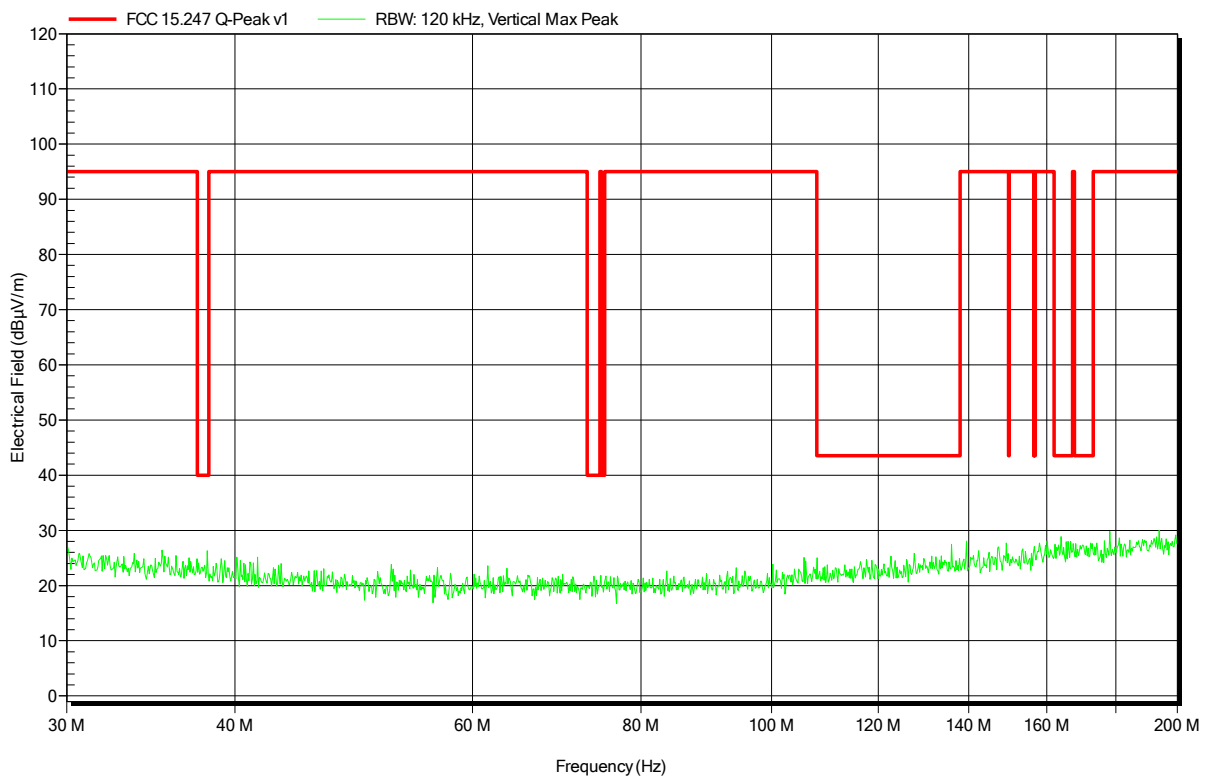

Spurious emissions according to FCC 15.247

Project number: G0M-1707-6725

Applicant: Leica Geosystems AG
 EUT Name: External GNSS Antenna
 Model: GG04 plus
 Test Site: Eurofins Product Service GmbH
 Operator: Mr. Suckow
 Test Conditions: Tnom: 22°C, Vnom: 12 VDC
 Antenna: Rohde & Schwarz HL 223, Horizontal
 Measurement distance: 3 m
 Mode: TX; BT 3DH5 2441 MHz
 Test Date: 2017-10-30
 Note:

Index 10

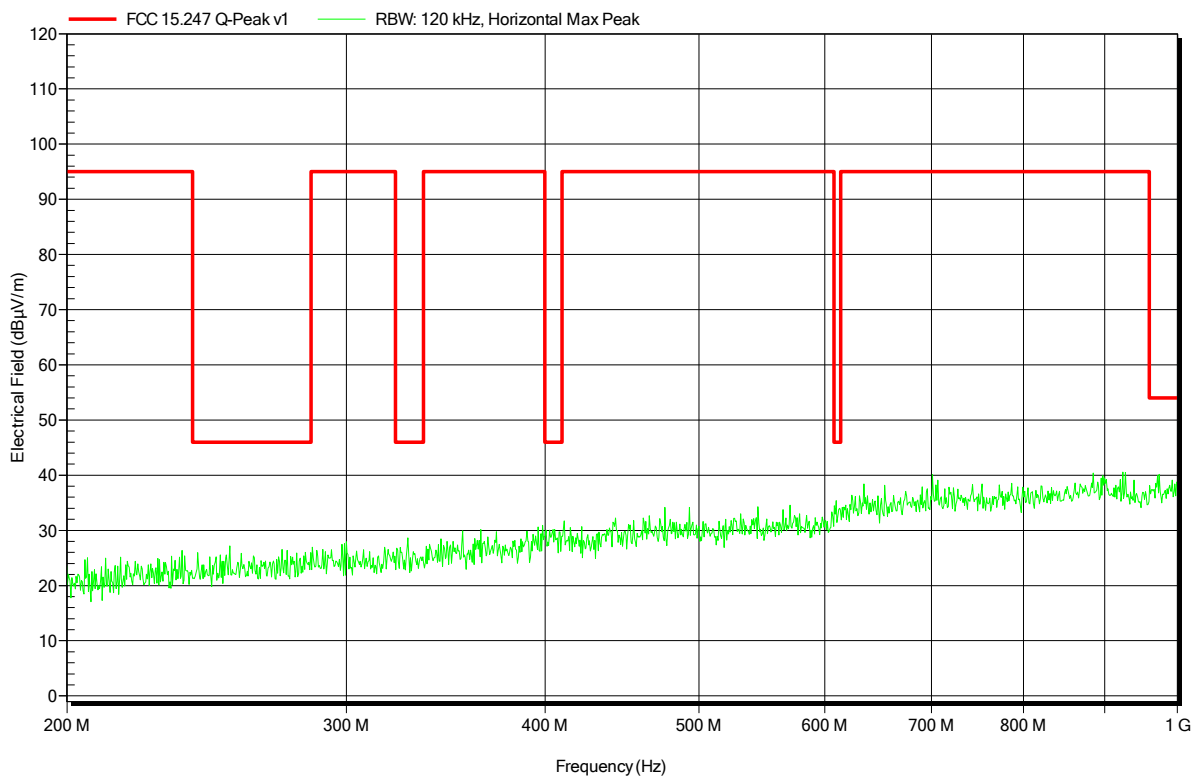

Spurious emissions according to FCC 15.247

Project number: G0M-1707-6725

Applicant:	Leica Geosystems AG
EUT Name:	External GNSS Antenna
Model:	GG04 plus
Test Site:	Eurofins Product Service GmbH
Operator:	Mr. Suckow
Test Conditions:	Tnom: 22°C, Vnom: 12 VDC
Antenna:	Rohde & Schwarz HL 223, Vertical
Measurement distance:	3 m
Mode:	TX; BT 3DH5 2441 MHz
Test Date:	2017-10-30
Note:	

Index 9

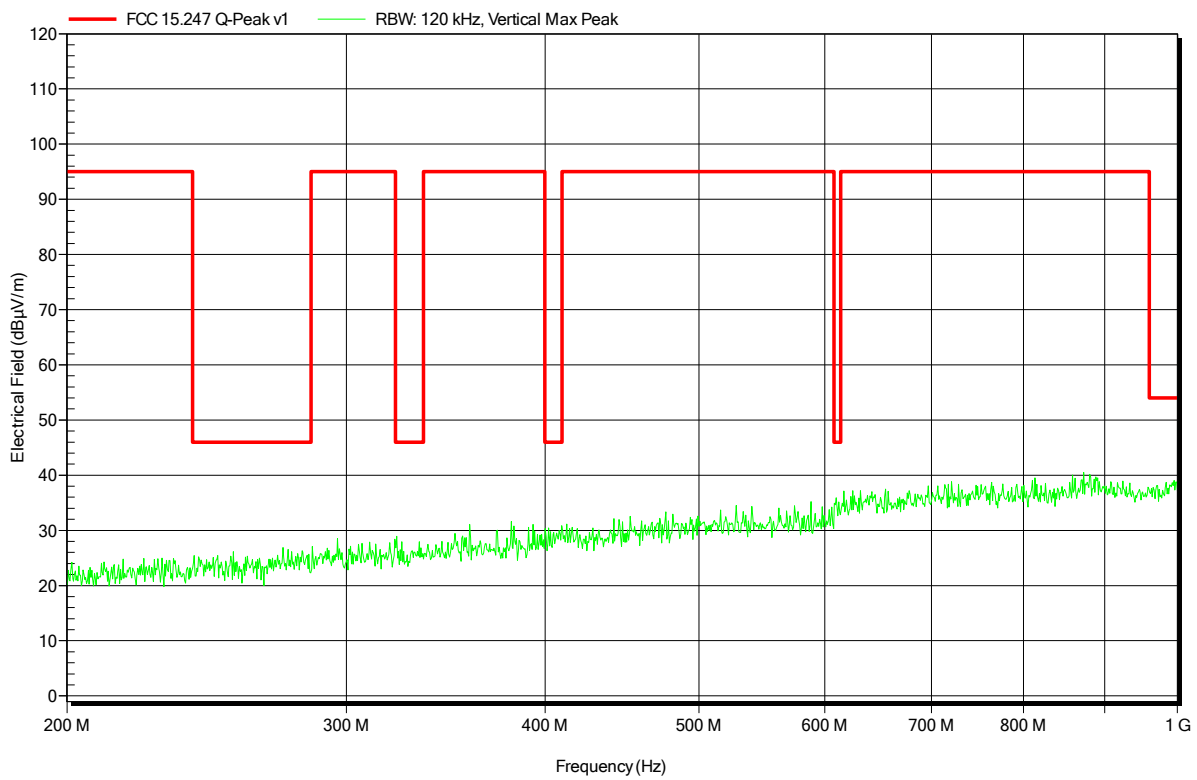

Spurious emissions according to FCC 15.247

Project number: G0M-1707-6725

Applicant: Leica Geosystems AG
 EUT Name: External GNSS Antenna
 Model: GG04 plus
 Test Site: Eurofins Product Service GmbH
 Operator: Sebastian Suckow
 Test Conditions: Tnom: 23°C, Vnom: 12 VDC
 Antenna: Schwarzbeck BBHA 9120D, Horizontal
 Measurement distance: 1 m converted to 3m
 Mode: TX; BT 3DH5 2441 MHz
 Test Date: 2017-10-27
 Note:

Index 10

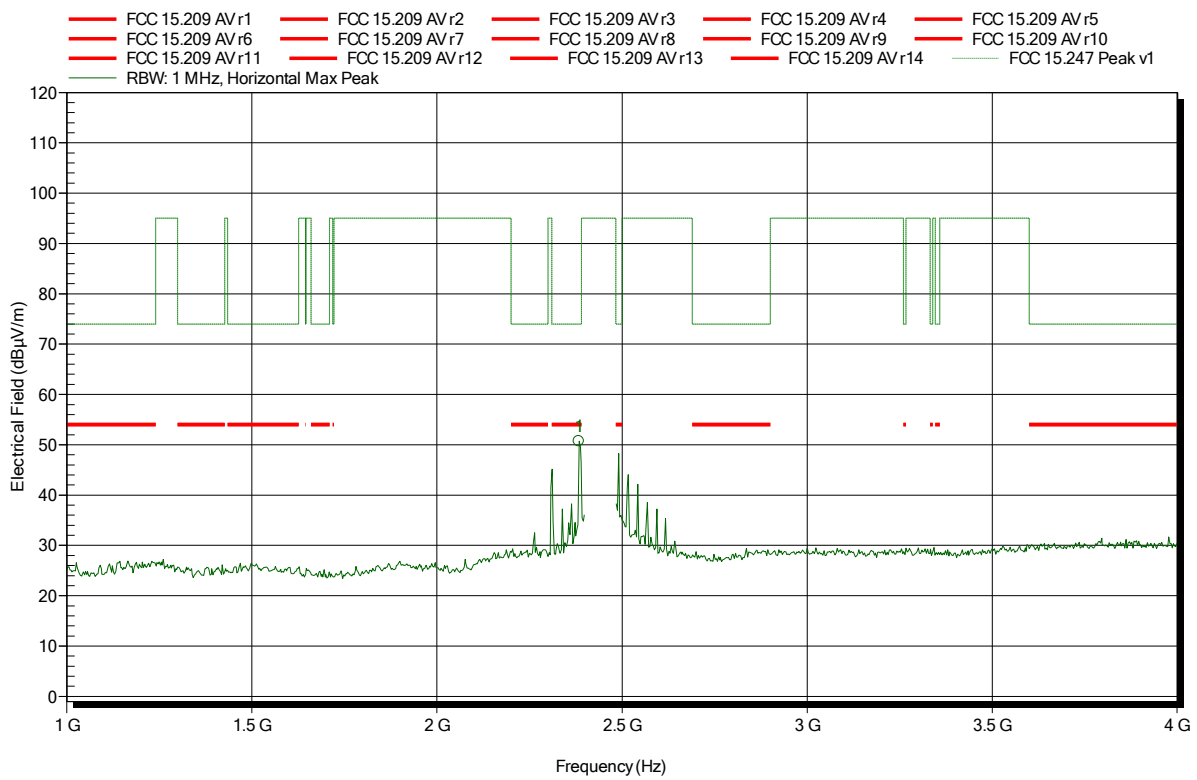

Frequency	Peak	Peak Limit	Peak Difference	Peak Status
2.3832 GHz	50.73 dBµV/m	74 dBµV/m	-23.27 dB	Pass

Spurious emissions according to FCC 15.247

Project number: G0M-1707-6725

Applicant: Leica Geosystems AG
 EUT Name: External GNSS Antenna
 Model: GG04 plus
 Test Site: Eurofins Product Service GmbH
 Operator: Sebastian Suckow
 Test Conditions: Tnom: 23°C, Vnom: 12 VDC
 Antenna: Schwarzbeck BBHA 9120D, Vertical
 Measurement distance: 1 m converted to 3m
 Mode: TX; BT 3DH5 2441 MHz
 Test Date: 2017-10-27
 Note:

Index 25

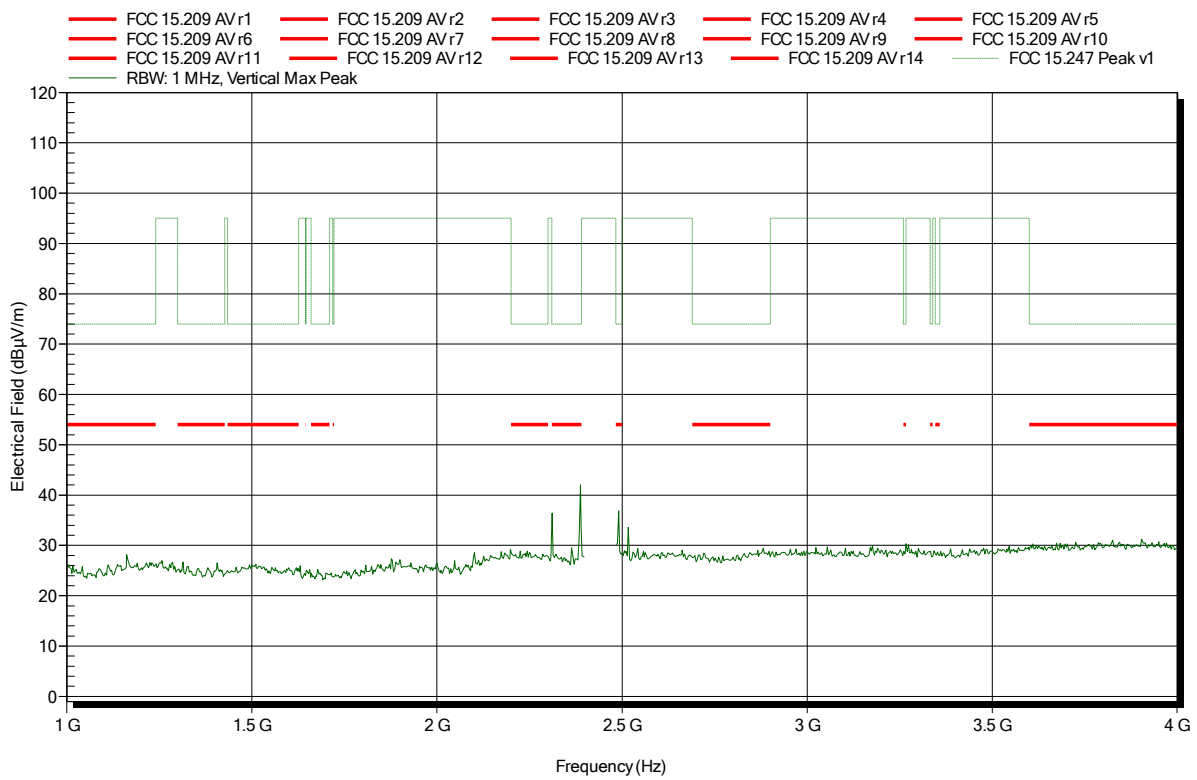

Spurious emissions according to FCC 15.247

Project number: G0M-1707-6725

Applicant: Leica Geosystems AG
 EUT Name: External GNSS Antenna
 Model: GG04 plus
 Test Site: Eurofins Product Service GmbH
 Operator: Sebastian Suckow
 Test Conditions: Tnom: 23°C, Vnom: 12 VDC
 Antenna: Schwarzbeck BBHA 9120D, Horizontal
 Measurement distance: 1 m converted to 3m
 Mode: TX; BT 3DH5 2441 MHz
 Test Date: 2017-10-27
 Note:

Index 11

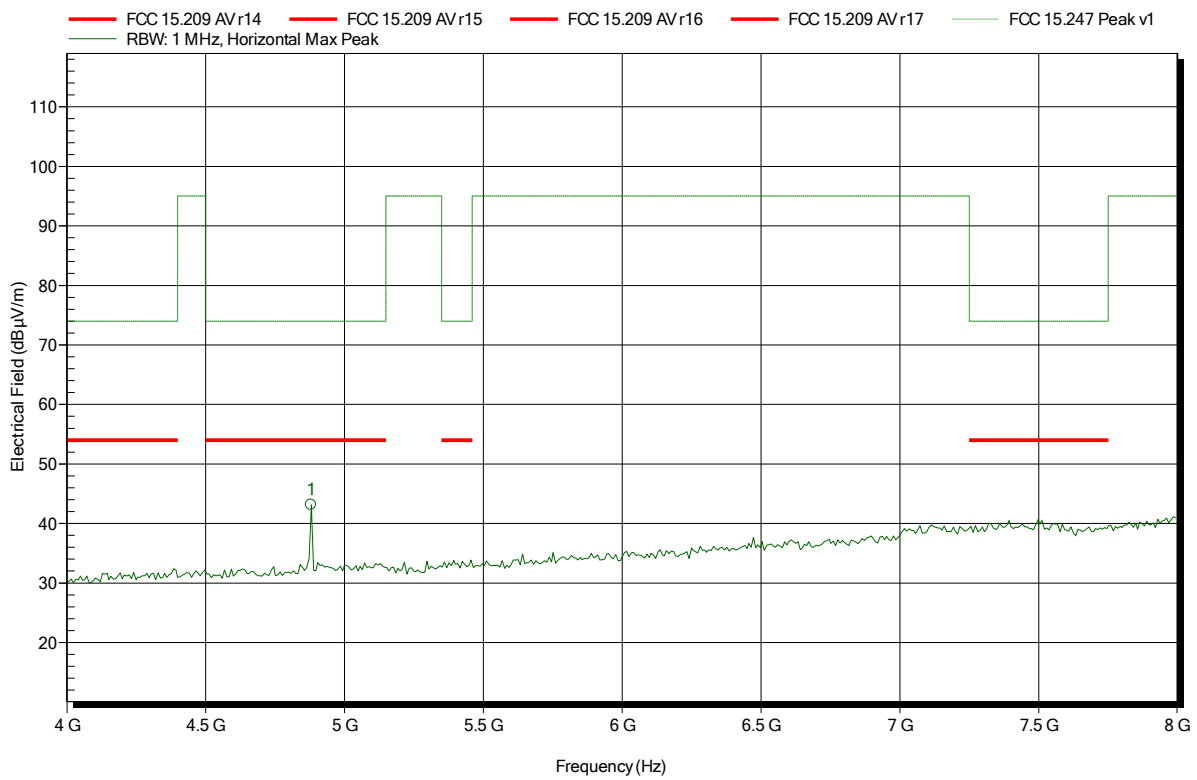

Frequency	Peak	Peak Limit	Peak Difference	Peak Status
4.88 GHz	43.12 dBµV/m	74 dBµV/m	-30.88 dB	Pass

Spurious emissions according to FCC 15.247

Project number: G0M-1707-6725

Applicant: Leica Geosystems AG
 EUT Name: External GNSS Antenna
 Model: GG04 plus
 Test Site: Eurofins Product Service GmbH
 Operator: Sebastian Suckow
 Test Conditions: Tnom: 23°C, Vnom: 12 VDC
 Antenna: Schwarzbeck BBHA 9120D, Vertical
 Measurement distance: 1 m converted to 3m
 Mode: TX; BT 3DH5 2441 MHz
 Test Date: 2017-10-27
 Note:

Index 24

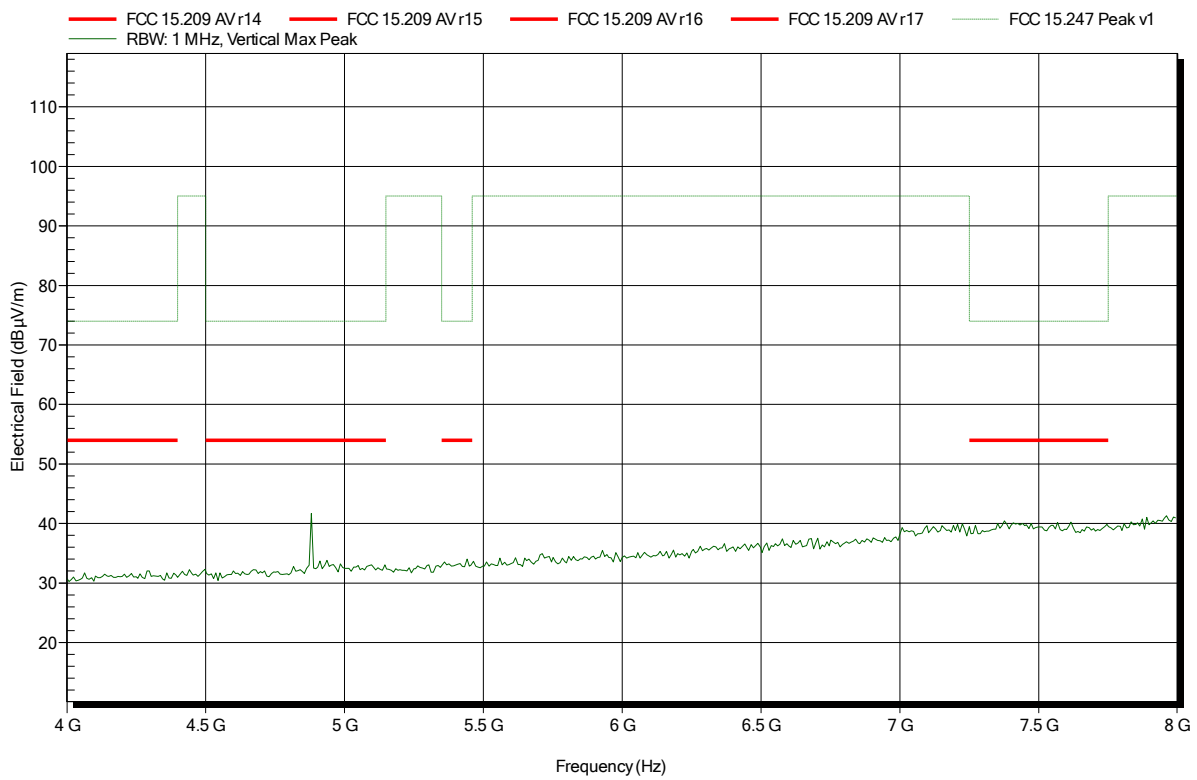

Spurious emissions according to FCC 15.247

Project number: G0M-1707-6725

Applicant: Leica Geosystems AG
 EUT Name: External GNSS Antenna
 Model: GG04 plus
 Test Site: Eurofins Product Service GmbH
 Operator: Sebastian Suckow
 Test Conditions: Tnom: 23°C, Vnom: 12 VDC
 Antenna: Schwarzbeck BBHA 9120D, Horizontal
 Measurement distance: 1 m converted to 3m
 Mode: TX; BT 3DH5 2441 MHz
 Test Date: 2017-10-27
 Note:

Index 12

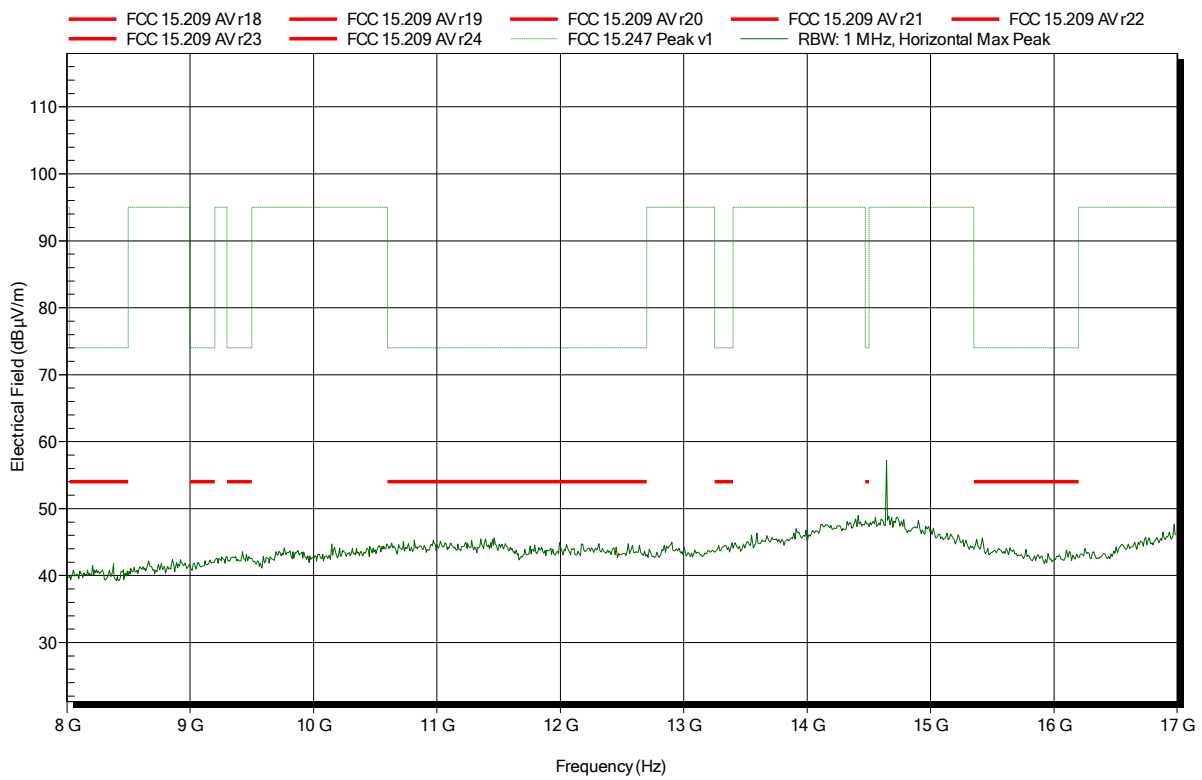

Spurious emissions according to FCC 15.247

Project number: G0M-1707-6725

Applicant: Leica Geosystems AG
 EUT Name: External GNSS Antenna
 Model: GG04 plus
 Test Site: Eurofins Product Service GmbH
 Operator: Sebastian Suckow
 Test Conditions: Tnom: 23°C, Vnom: 12 VDC
 Antenna: Schwarzbeck BBHA 9120D, Vertical
 Measurement distance: 1 m converted to 3m
 Mode: TX; BT 3DH5 2441 MHz
 Test Date: 2017-10-27
 Note:

Index 23

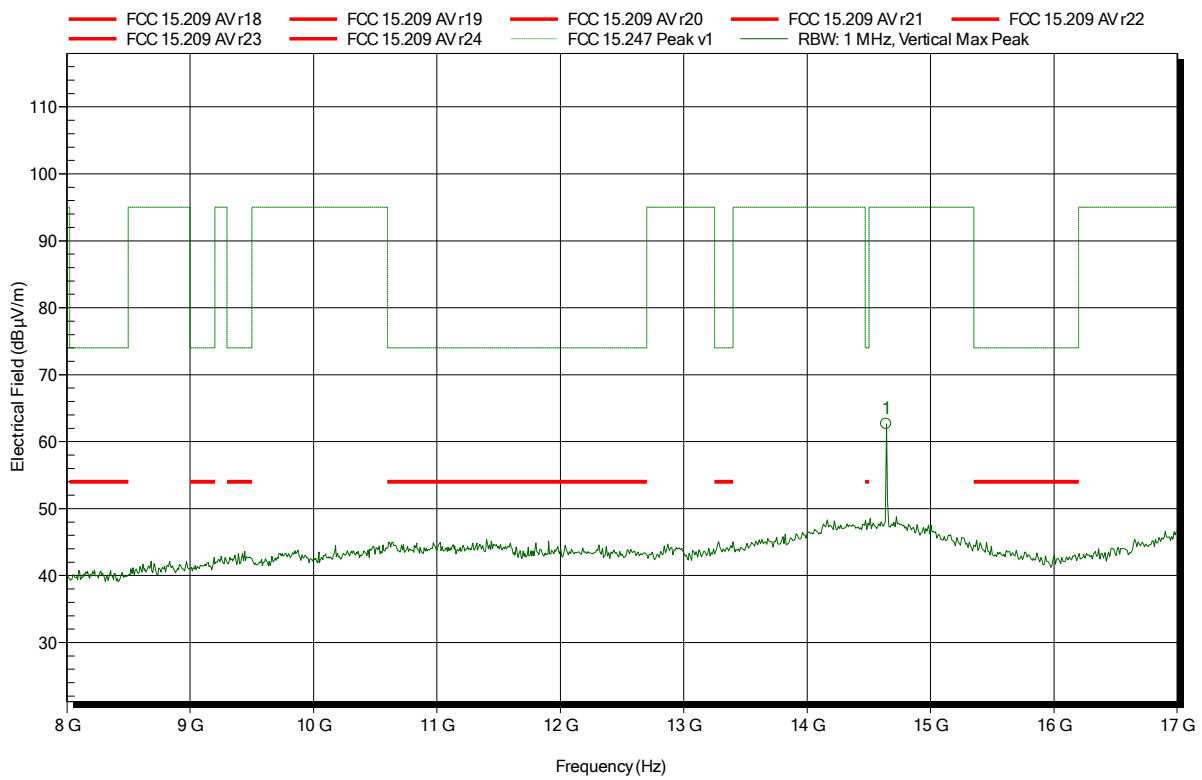

Frequency	Peak	Peak Limit	Peak Difference	Peak Status
14.64 GHz	62.65 dBµV/m	95 dBµV/m	-32.35 dB	Pass

Spurious emissions according to FCC 15.247

Project number: G0M-1707-6725

Applicant: Leica Geosystems AG
 EUT Name: External GNSS Antenna
 Model: GG04 plus
 Test Site: Eurofins Product Service GmbH
 Operator: Sebastian Suckow
 Test Conditions: Tnom: 23°C, Vnom: 12 VDC
 Antenna: Amplifier Research AT 4560, Horizontal
 Measurement distance: 1 m converted to 3m
 Mode: TX; BT 3DH5 2441 MHz
 Test Date: 2017-10-27
 Note:

Index 5

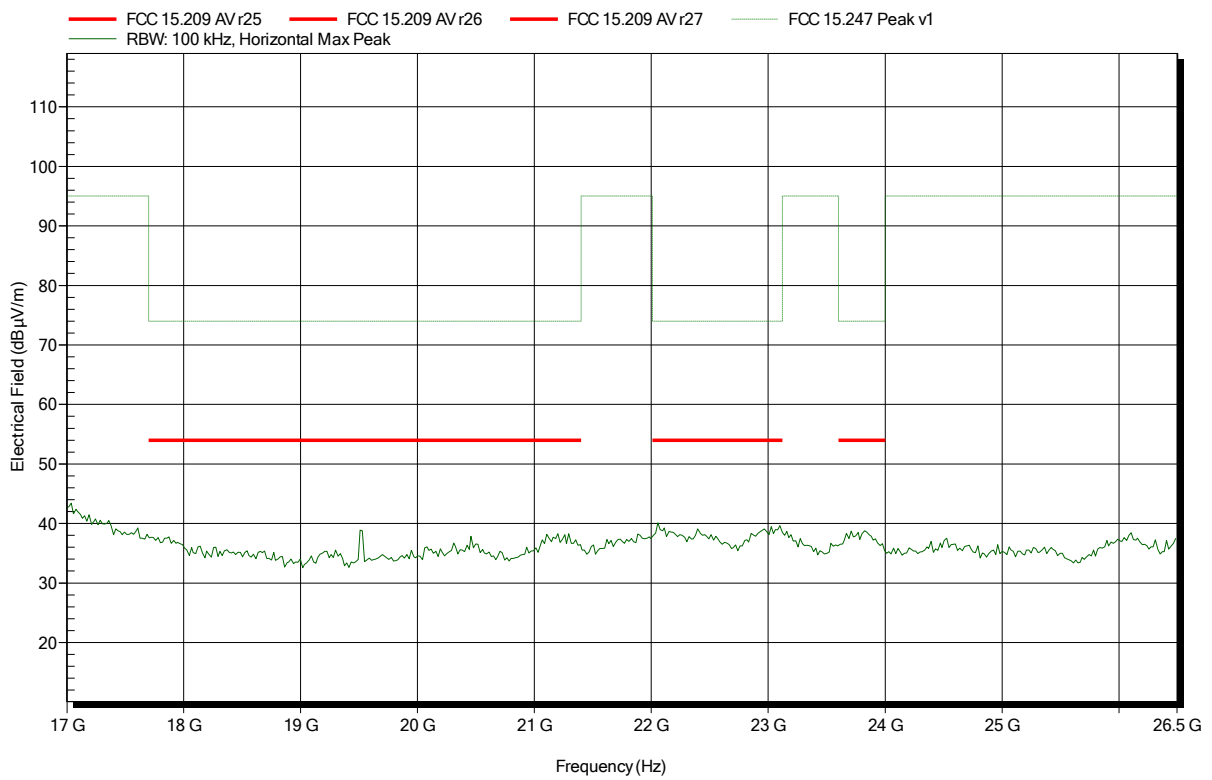

Spurious emissions according to FCC 15.247

Project number: G0M-1707-6725

Applicant: Leica Geosystems AG
 EUT Name: External GNSS Antenna
 Model: GG04 plus
 Test Site: Eurofins Product Service GmbH
 Operator: Sebastian Suckow
 Test Conditions: Tnom: 23°C, Vnom: 12 VDC
 Antenna: Amplifier Research AT 4560, Vertical
 Measurement distance: 1 m converted to 3m
 Mode: TX; BT 3DH5 2441 MHz
 Test Date: 2017-10-27
 Note:

Index 2

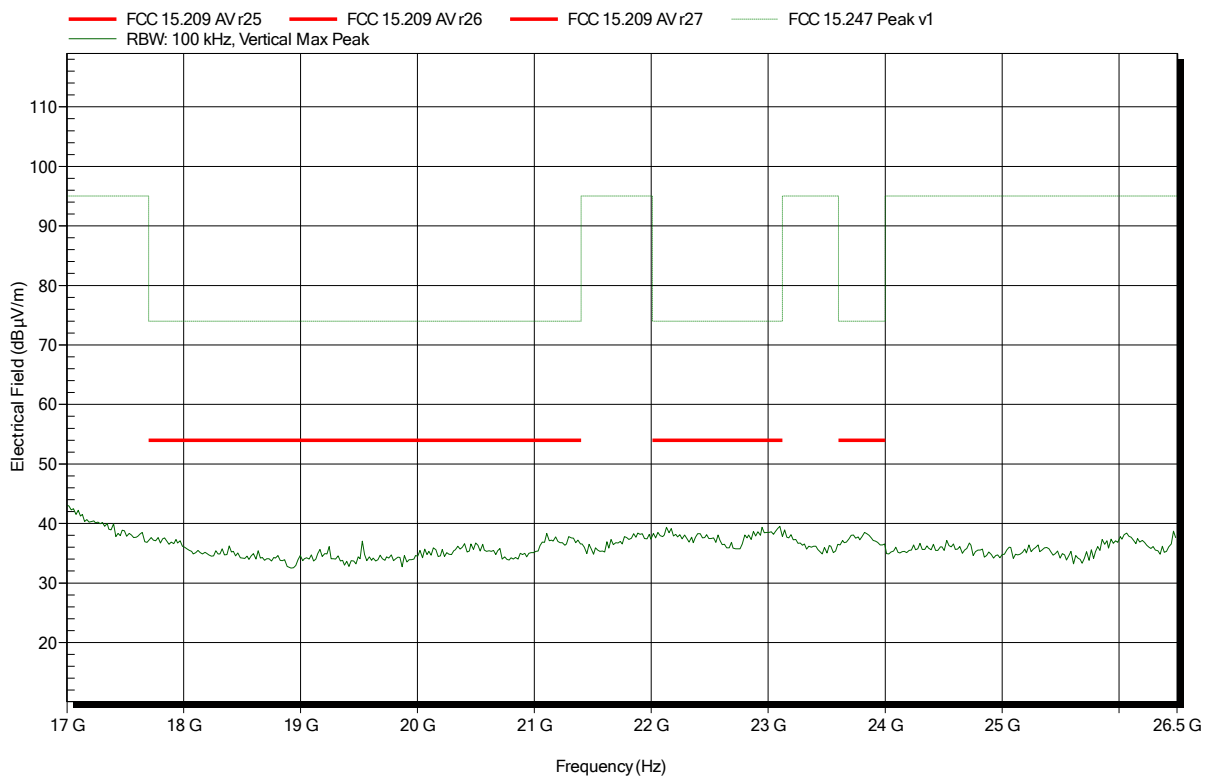

Spurious emissions according to FCC 15.247

Project number: G0M-1707-6725

Applicant: Leica Geosystems AG
 EUT Name: External GNSS Antenna
 Model: GG04 plus
 Test Site: Eurofins Product Service GmbH
 Operator: Mr. Suckow
 Test Conditions: Tnom: 22°C, Vnom: 12 VDC
 Antenna: Rohde & Schwarz HK 116, Horizontal
 Measurement distance: 3 m
 Mode: TX; BT 3DH5 2480 MHz
 Test Date: 2017-10-30
 Note:

Index 6

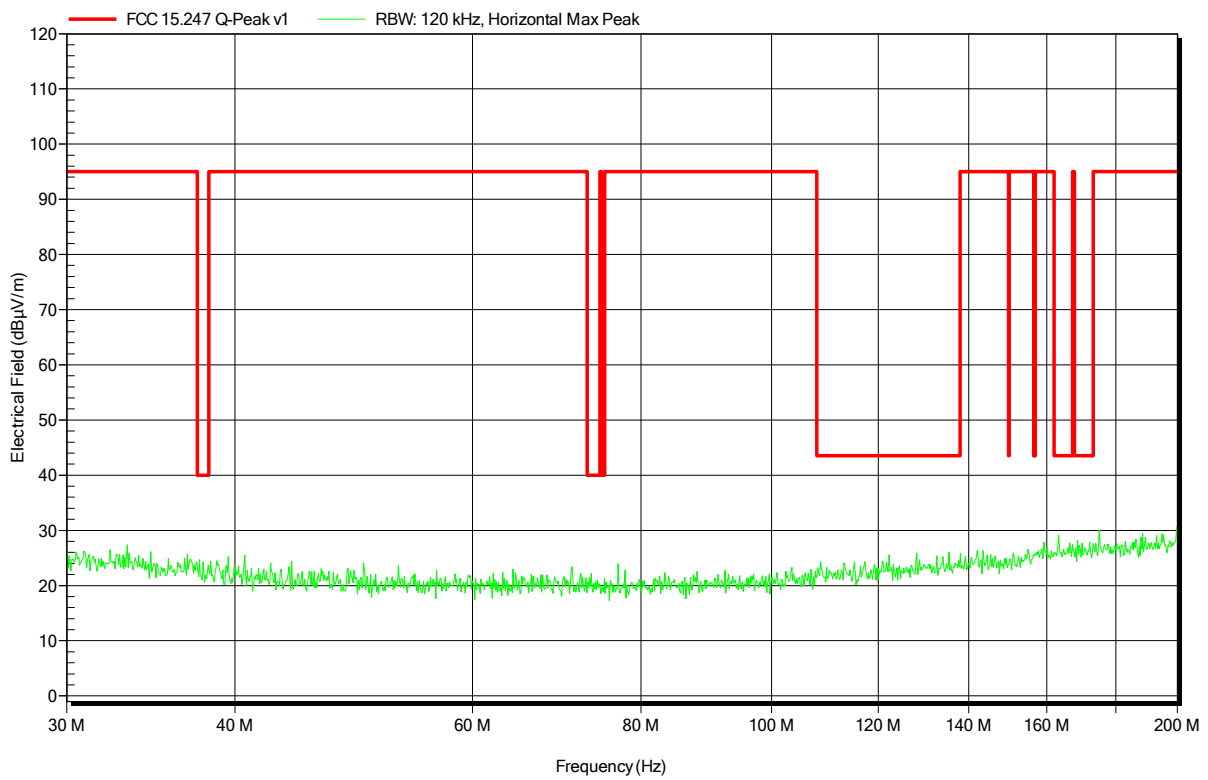

Spurious emissions according to FCC 15.247

Project number: G0M-1707-6725

Applicant: Leica Geosystems AG
 EUT Name: External GNSS Antenna
 Model: GG04 plus
 Test Site: Eurofins Product Service GmbH
 Operator: Mr. Suckow
 Test Conditions: Tnom: 22°C, Vnom: 12 VDC
 Antenna: Rohde & Schwarz HK 116, Vertical
 Measurement distance: 3 m
 Mode: TX; BT 3DH5 2480 MHz
 Test Date: 2017-10-30
 Note:

Index 5

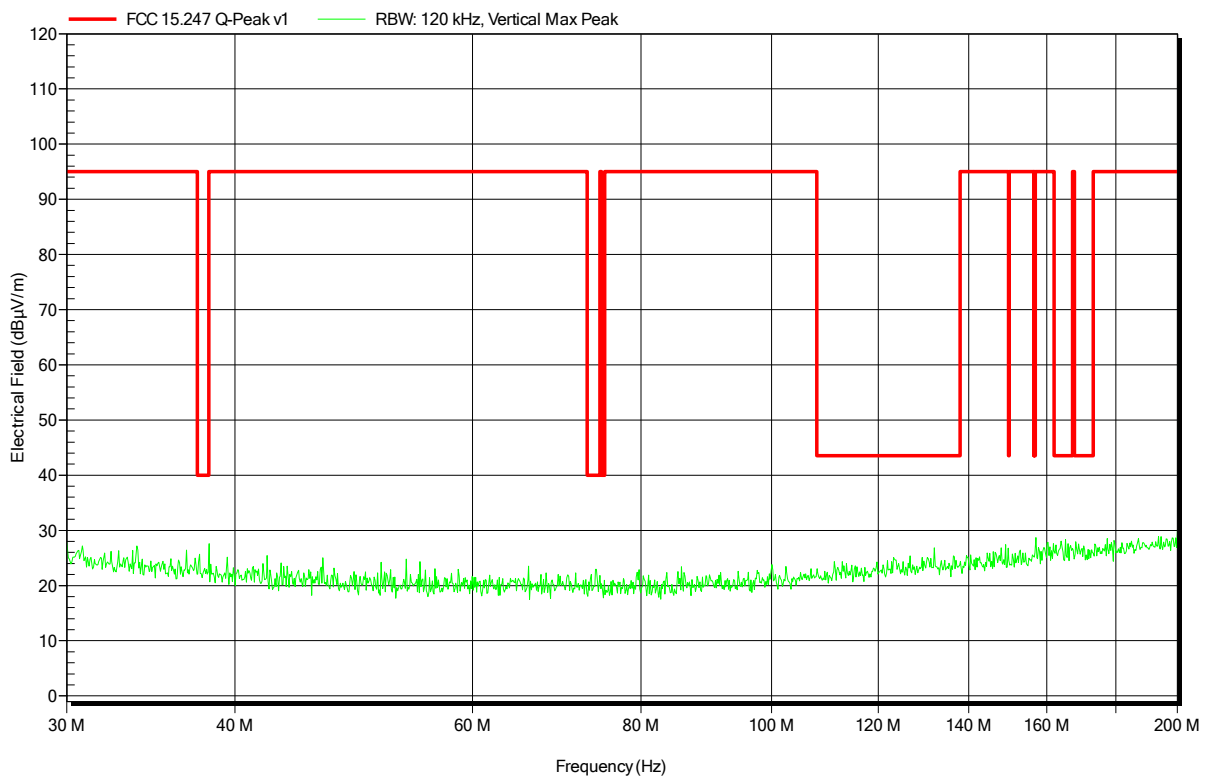

Spurious emissions according to FCC 15.247

Project number: G0M-1707-6725

Applicant: Leica Geosystems AG
 EUT Name: External GNSS Antenna
 Model: GG04 plus
 Test Site: Eurofins Product Service GmbH
 Operator: Mr. Suckow
 Test Conditions: Tnom: 22°C, Vnom: 12 VDC
 Antenna: Rohde & Schwarz HL 223, Horizontal
 Measurement distance: 3 m
 Mode: TX; BT 3DH5 2480 MHz
 Test Date: 2017-10-30
 Note:

Index 7

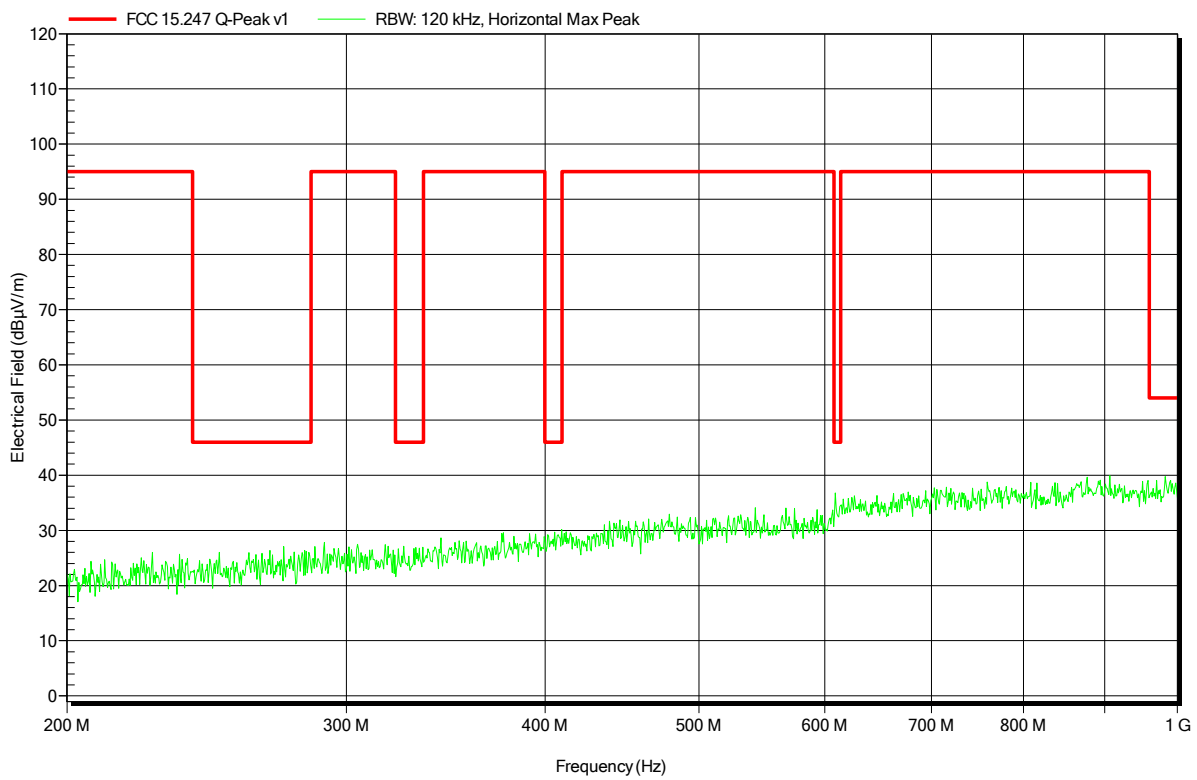

Spurious emissions according to FCC 15.247

Project number: G0M-1707-6725

Applicant: Leica Geosystems AG
 EUT Name: External GNSS Antenna
 Model: GG04 plus
 Test Site: Eurofins Product Service GmbH
 Operator: Mr. Suckow
 Test Conditions: Tnom: 22°C, Vnom: 12 VDC
 Antenna: Rohde & Schwarz HL 223, Vertical
 Measurement distance: 3 m
 Mode: TX; BT 3DH5 2480 MHz
 Test Date: 2017-10-30
 Note:

Index 8

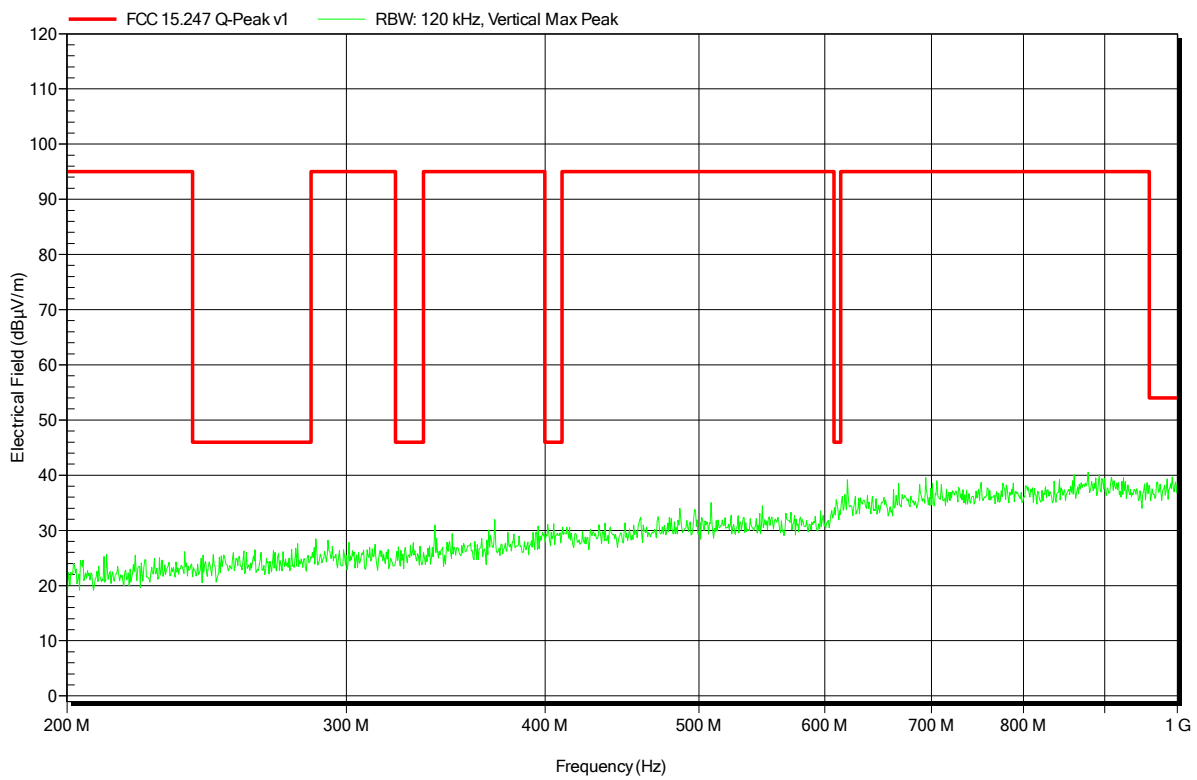

Spurious emissions according to FCC 15.247

Project number: GOM-1707-6725

Applicant: Leica Geosystems AG
 EUT Name: External GNSS Antenna
 Model: GG04 plus
 Test Site: Eurofins Product Service GmbH
 Operator: Sebastian Suckow
 Test Conditions: Tnom: 23°C, Vnom: 12 VDC
 Antenna: Schwarzbeck BBHA 9120D, Horizontal
 Measurement distance: 1 m converted to 3m
 Mode: TX; BT 3DH5 2480 MHz
 Test Date: 2017-10-27
 Note:

Index 15

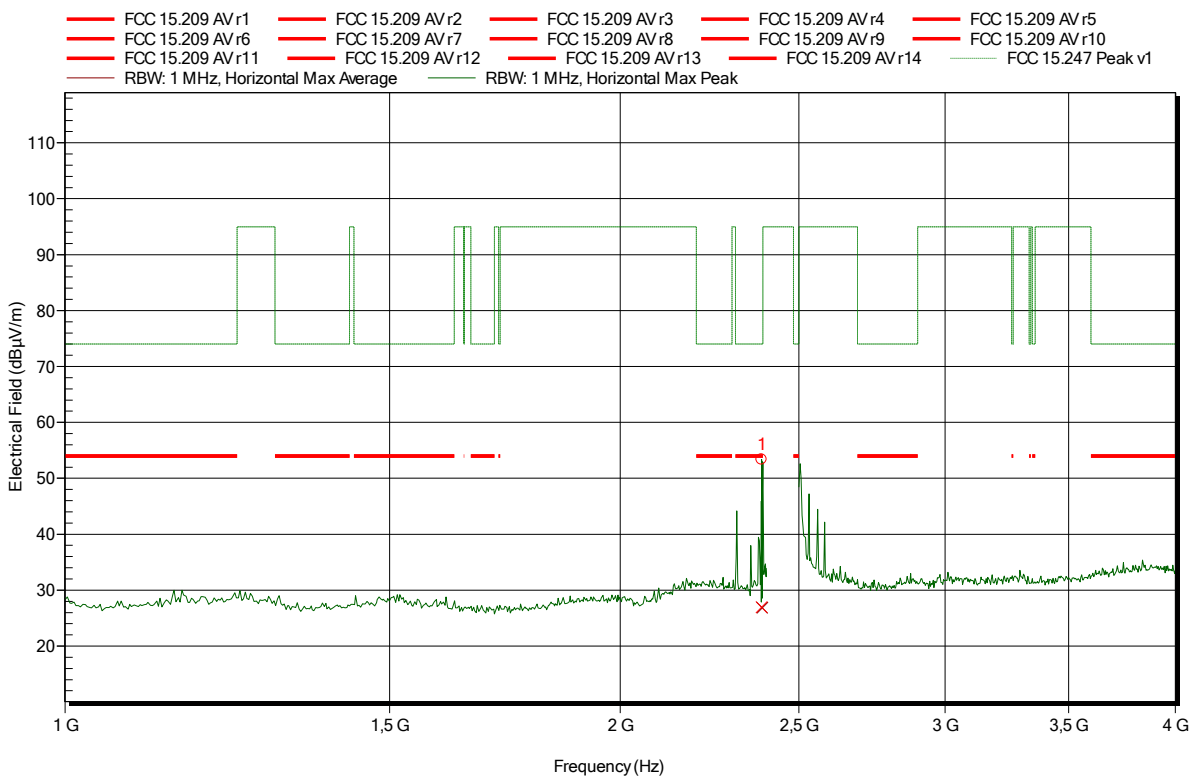

Frequency	Peak	Peak Limit	Peak Difference	Peak Status
2,386 GHz	53,33 dBµV/m	74 dBµV/m	-20,67 dB	Pass
Frequency	Average	Average Limit	Average Difference	Average Status
2,386 GHz	26,93 dBµV/m	54 dBµV/m	-27,07 dB	Pass

Spurious emissions according to FCC 15.247

Project number: G0M-1707-6725

Applicant: Leica Geosystems AG
 EUT Name: External GNSS Antenna
 Model: GG04 plus
 Test Site: Eurofins Product Service GmbH
 Operator: Sebastian Suckow
 Test Conditions: Tnom: 23°C, Vnom: 12 VDC
 Antenna: Schwarzbeck BBHA 9120D, Vertical
 Measurement distance: 1 m converted to 3m
 Mode: TX; BT 3DH5 2480 MHz
 Test Date: 2017-10-27
 Note:

Index 26

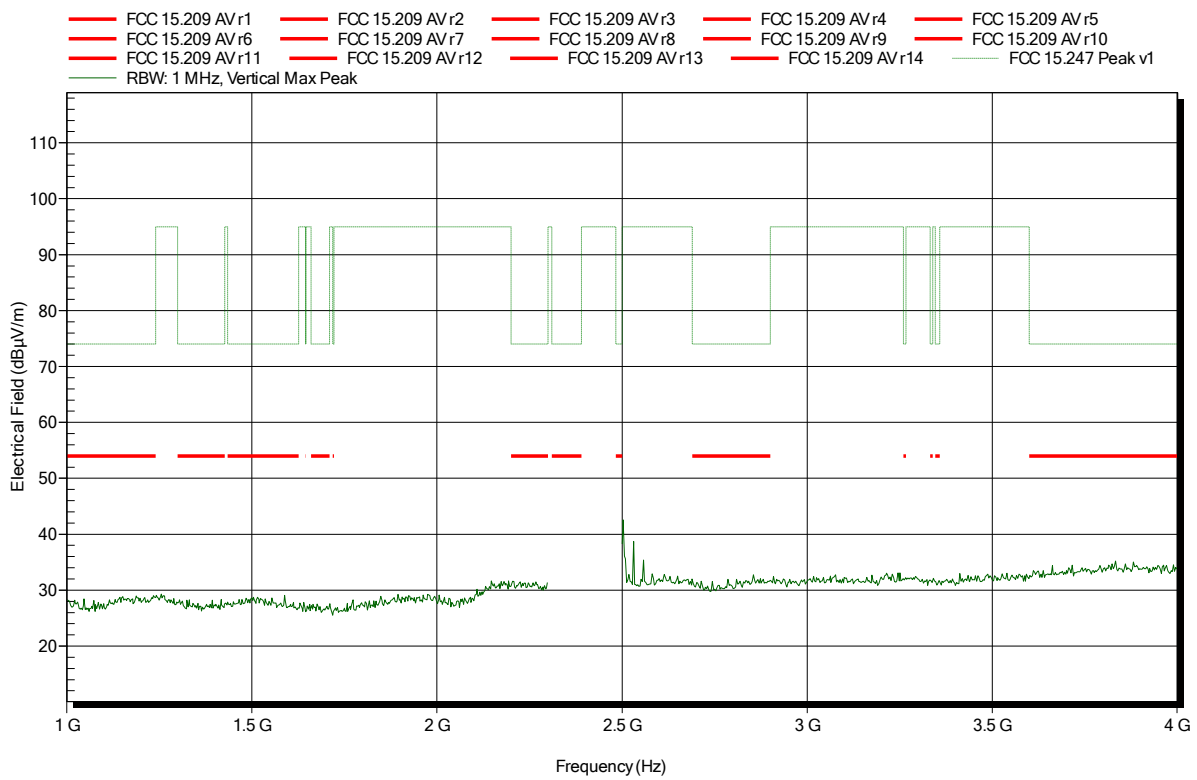

Spurious emissions according to FCC part 15 Subpart C § 15.247

Project number: G0M-1707-6725

Applicant: Leica Geosystems AG
 EUT Name: External GNSS Antenna
 Model: GG04 plus
 Test Site: Eurofins Product Service GmbH
 Operator: Mr. Suckow
 Test Conditions: Tnom: 24°C, Vnom: 12 VDC
 Antenna: Schwarzbeck BBHA 9120D, Horizontal
 Measurement distance: 3 m
 Mode: TX; BT DH5 2480 MHz
 Test Date: 2017-11-08
 Note: higher bandedge

Index 4

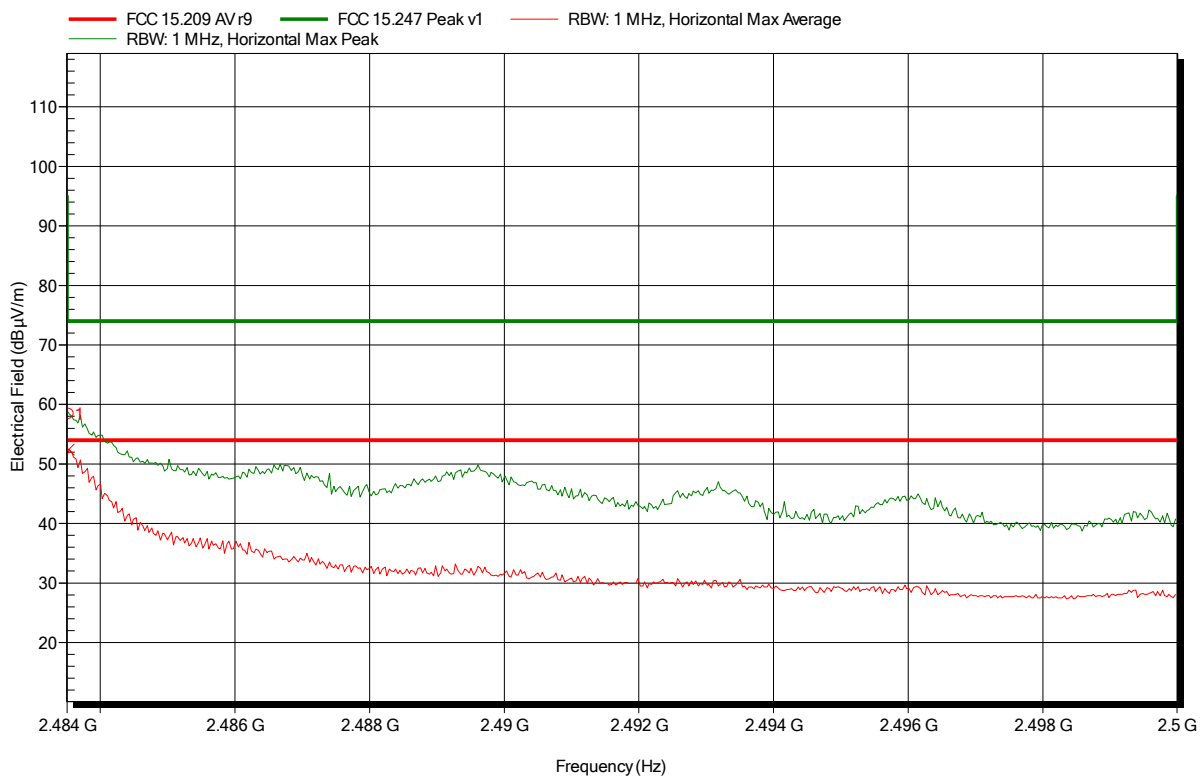

Frequency	Peak	Peak Limit	Peak Difference	Peak Status
2.484 GHz	58.42 dBµV/m	74 dBµV/m	-15.58 dB	Pass
Frequency	Average	Average Limit	Average Difference	Average Status
2.484 GHz	52.42 dBµV/m	54 dBµV/m	-1.58 dB	Pass

Spurious emissions according to FCC part 15 Subpart C § 15.247

Project number: G0M-1707-6725

Applicant: Leica Geosystems AG
 EUT Name: External GNSS Antenna
 Model: GG04 plus
 Test Site: Eurofins Product Service GmbH
 Operator: Mr. Suckow
 Test Conditions: Tnom: 24°C, Vnom: 12 VDC
 Antenna: Schwarzbeck BBHA 9120D, Vertical
 Measurement distance: 3 m
 Mode: TX; BT DH5 2480 MHz
 Test Date: 2017-11-08
 Note: higher bandedge

Index 9

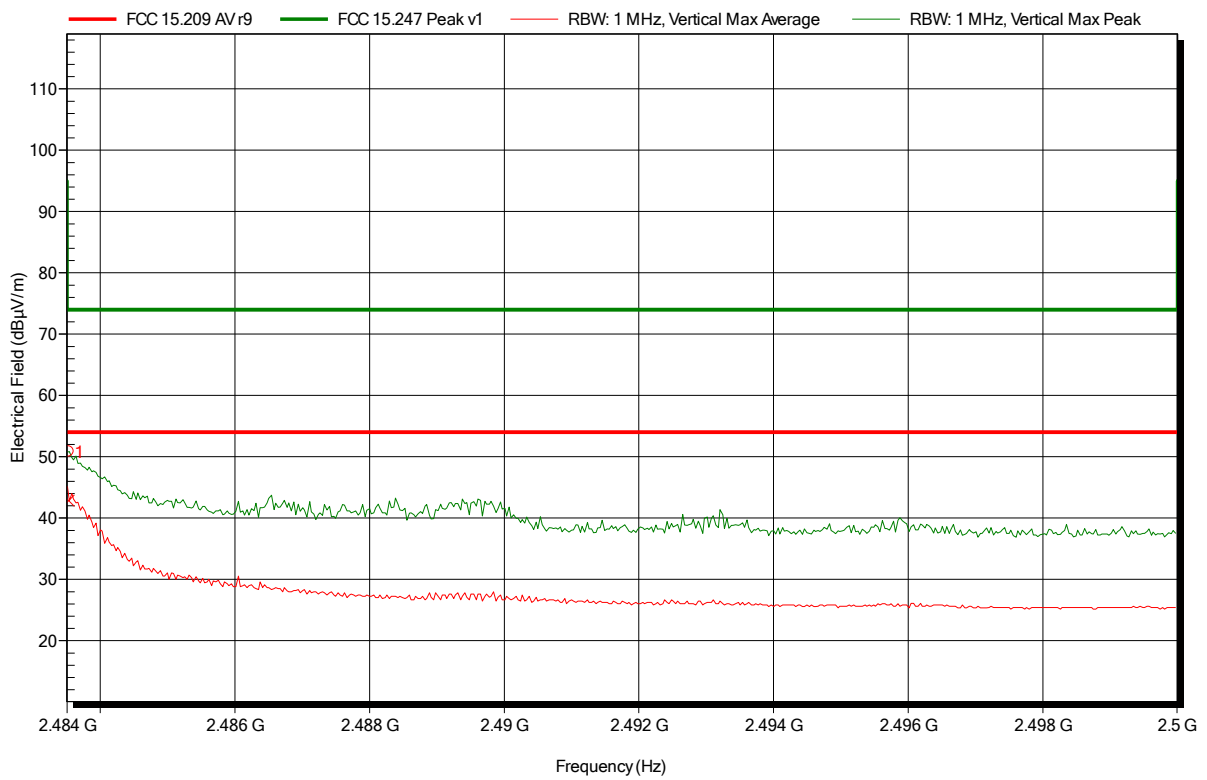

Frequency	Peak	Peak Limit	Peak Difference	Peak Status
2.484 GHz	50.86 dBµV/m	74 dBµV/m	-23.14 dB	Pass
Frequency	Average	Average Limit	Average Difference	Average Status
2.484 GHz	42.83 dBµV/m	54 dBµV/m	-11.17 dB	Pass

Spurious emissions according to FCC part 15 Subpart C § 15.247

Project number: G0M-1707-6725

Applicant: Leica Geosystems AG
 EUT Name: External GNSS Antenna
 Model: GG04 plus
 Test Site: Eurofins Product Service GmbH
 Operator: Mr. Suckow
 Test Conditions: Tnom: 24°C, Vnom: 12 VDC
 Antenna: Schwarzbeck BBHA 9120D, Horizontal
 Measurement distance: 3 m
 Mode: TX; BT 2DH5 2480 MHz
 Test Date: 2017-11-08
 Note: higher bandedge

Index 5

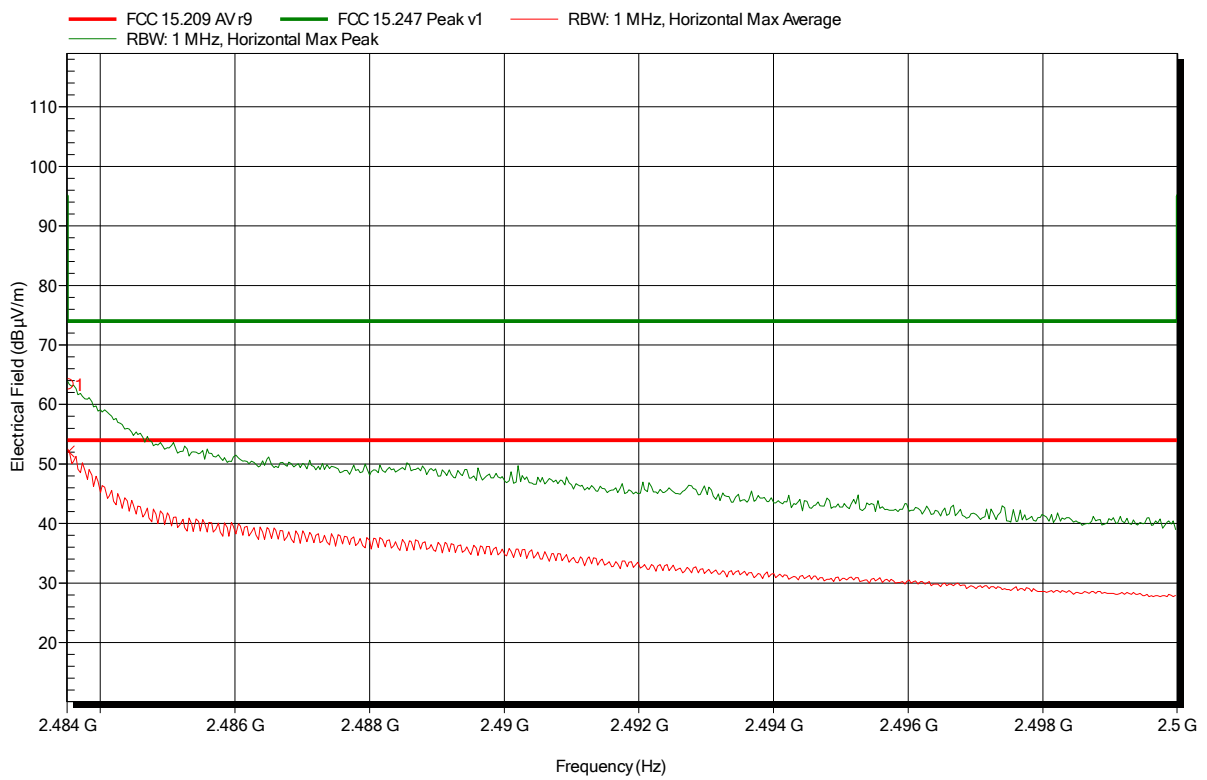

Frequency	Peak	Peak Limit	Peak Difference	Peak Status
2.484 GHz	63.39 dBµV/m	74 dBµV/m	-10.61 dB	Pass
Frequency	Average	Average Limit	Average Difference	Average Status
2.484 GHz	52.09 dBµV/m	54 dBµV/m	-1.91 dB	Pass

Spurious emissions according to FCC part 15 Subpart C § 15.247

Project number: G0M-1707-6725

Applicant: Leica Geosystems AG
 EUT Name: External GNSS Antenna
 Model: GG04 plus
 Test Site: Eurofins Product Service GmbH
 Operator: Mr. Suckow
 Test Conditions: Tnom: 24°C, Vnom: 12 VDC
 Antenna: Schwarzbeck BBHA 9120D, Vertical
 Measurement distance: 3 m
 Mode: TX; BT 2DH5 2480 MHz
 Test Date: 2017-11-08
 Note: higher bandedge

Index 8

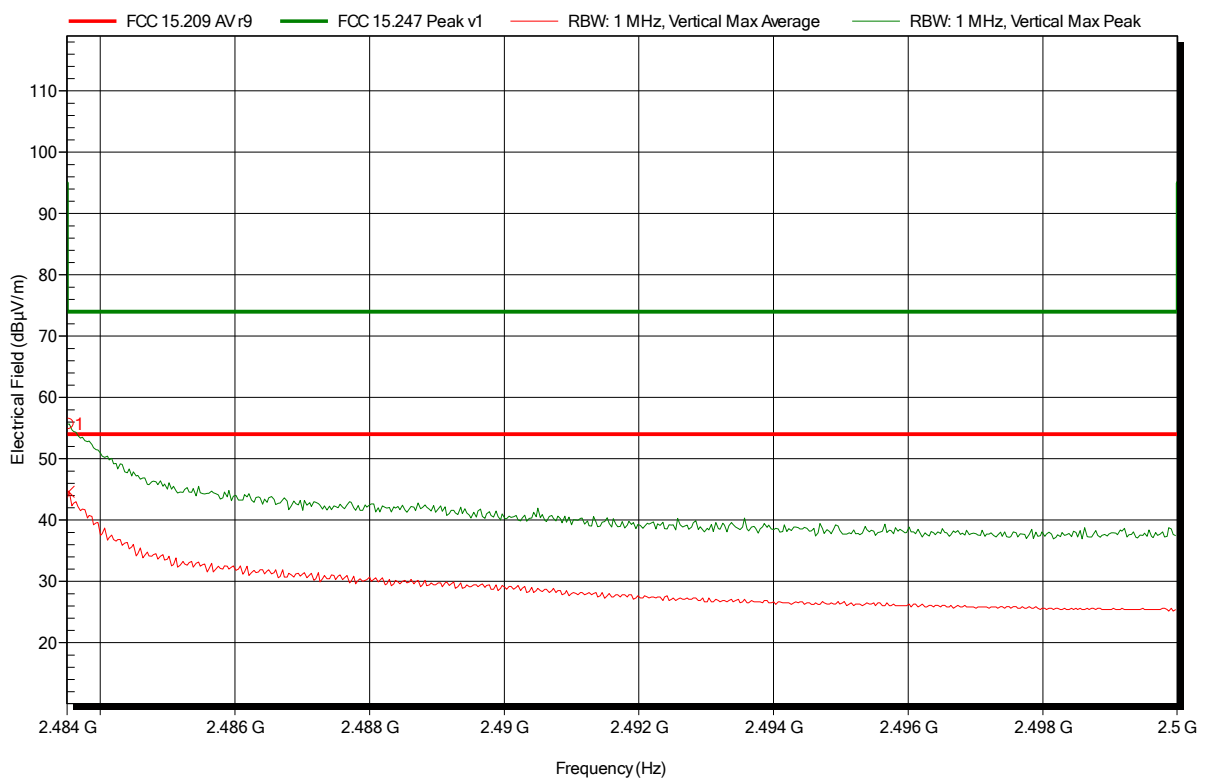

Frequency	Peak	Peak Limit	Peak Difference	Peak Status
2.484 GHz	55.7 dBµV/m	74 dBµV/m	-18.3 dB	Pass
Frequency	Average	Average Limit	Average Difference	Average Status
2.484 GHz	44.64 dBµV/m	54 dBµV/m	-9.36 dB	Pass

Spurious emissions according to FCC part 15 Subpart C § 15.247

Project number: G0M-1707-6725

Applicant: Leica Geosystems AG
 EUT Name: External GNSS Antenna
 Model: GG04 plus
 Test Site: Eurofins Product Service GmbH
 Operator: Mr. Suckow
 Test Conditions: Tnom: 24°C, Vnom: 12 VDC
 Antenna: Schwarzbeck BBHA 9120D, Horizontal
 Measurement distance: 3 m
 Mode: TX; BT 3DH5 2480 MHz
 Test Date: 2017-11-08
 Note: higher bandedge

Index 6

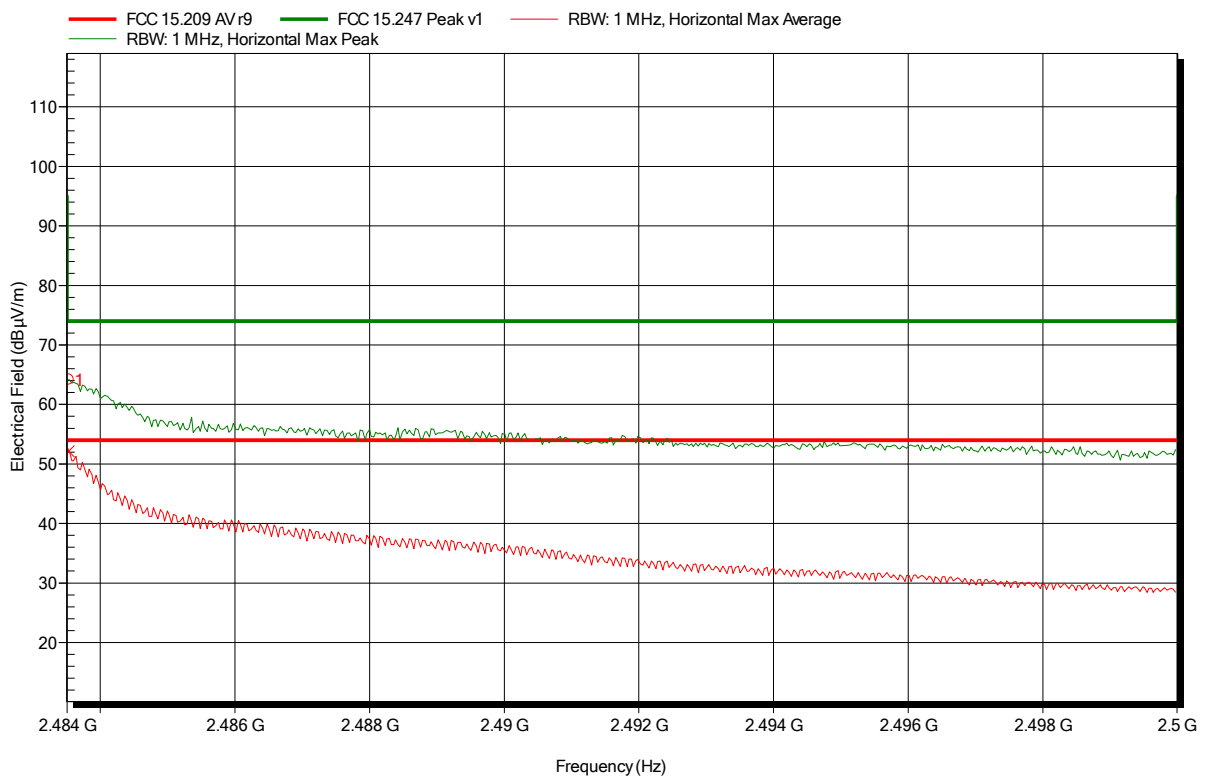

Frequency	Peak	Peak Limit	Peak Difference	Peak Status
2.484 GHz	64.19 dBµV/m	74 dBµV/m	-9.81 dB	Pass
Frequency	Average	Average Limit	Average Difference	Average Status
2.484 GHz	52.14 dBµV/m	54 dBµV/m	-1.86 dB	Pass

Spurious emissions according to FCC part 15 Subpart C § 15.247

Project number: G0M-1707-6725

Applicant: Leica Geosystems AG
 EUT Name: External GNSS Antenna
 Model: GG04 plus
 Test Site: Eurofins Product Service GmbH
 Operator: Mr. Suckow
 Test Conditions: Tnom: 24°C, Vnom: 12 VDC
 Antenna: Schwarzbeck BBHA 9120D, Vertical
 Measurement distance: 3 m
 Mode: TX; BT 3DH5 2480 MHz
 Test Date: 2017-11-08
 Note: higher bandedge

Index 7

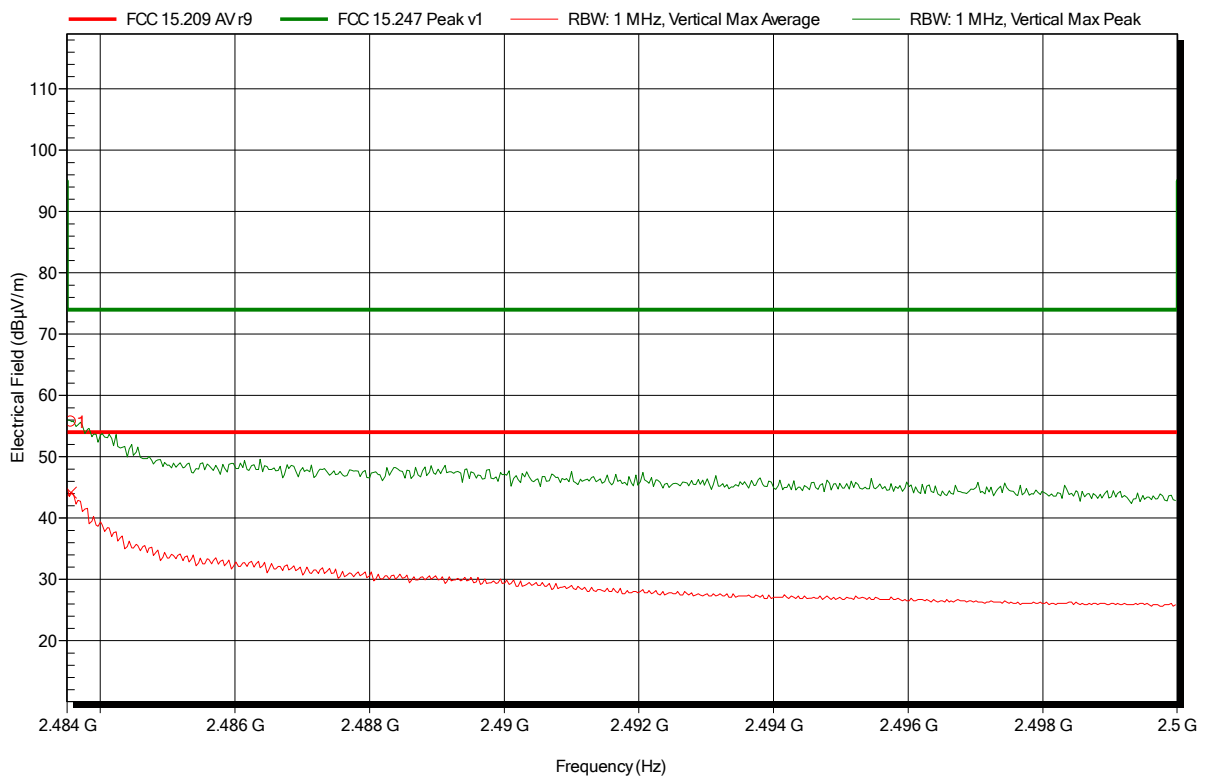

Frequency	Peak	Peak Limit	Peak Difference	Peak Status
2.484 GHz	55.72 dBµV/m	74 dBµV/m	-18.28 dB	Pass
Frequency	Average	Average Limit	Average Difference	Average Status
2.484 GHz	44.16 dBµV/m	54 dBµV/m	-9.84 dB	Pass

Spurious emissions according to FCC 15.247

Project number: G0M-1707-6725

Applicant: Leica Geosystems AG
 EUT Name: External GNSS Antenna
 Model: GG04 plus
 Test Site: Eurofins Product Service GmbH
 Operator: Sebastian Suckow
 Test Conditions: Tnom: 23°C, Vnom: 12 VDC
 Antenna: Schwarzbeck BBHA 9120D, Horizontal
 Measurement distance: 1 m converted to 3m
 Mode: TX; BT 3DH5 2480 MHz
 Test Date: 2017-10-27
 Note:

Index 14

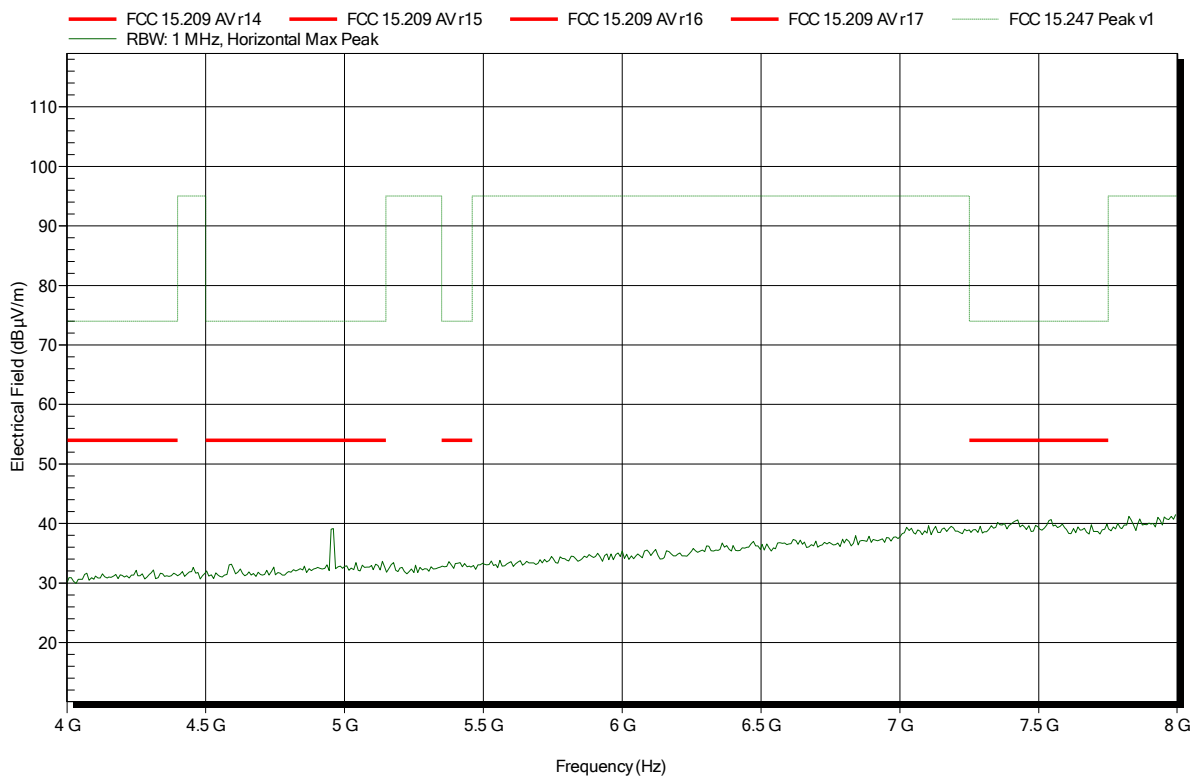

Spurious emissions according to FCC 15.247

Project number: G0M-1707-6725

Applicant: Leica Geosystems AG
 EUT Name: External GNSS Antenna
 Model: GG04 plus
 Test Site: Eurofins Product Service GmbH
 Operator: Sebastian Suckow
 Test Conditions: Tnom: 23°C, Vnom: 12 VDC
 Antenna: Schwarzbeck BBHA 9120D, Horizontal
 Measurement distance: 1 m converted to 3m
 Mode: TX; BT 3DH5 2480 MHz
 Test Date: 2017-10-27
 Note:

Index 13

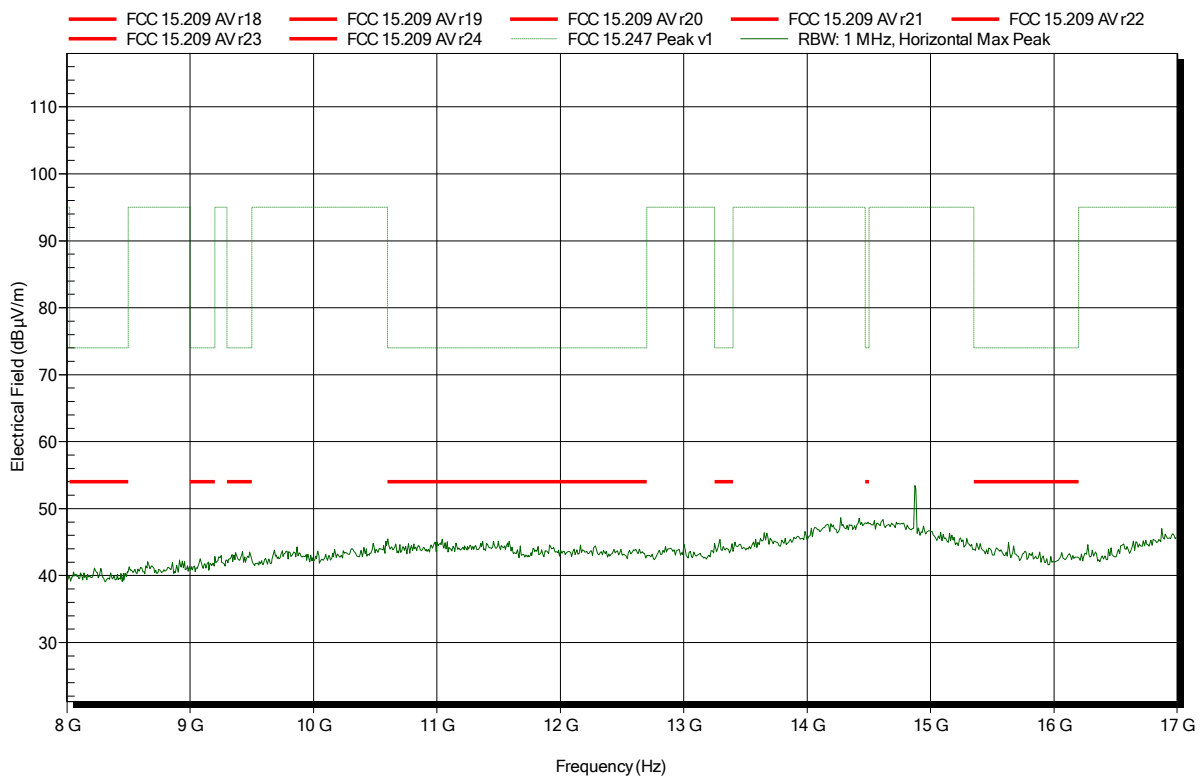

Spurious emissions according to FCC 15.247

Project number: G0M-1707-6725

Applicant: Leica Geosystems AG
 EUT Name: External GNSS Antenna
 Model: GG04 plus
 Test Site: Eurofins Product Service GmbH
 Operator: Sebastian Suckow
 Test Conditions: Tnom: 23°C, Vnom: 12 VDC
 Antenna: Schwarzbeck BBHA 9120D, Vertical
 Measurement distance: 1 m converted to 3m
 Mode: TX; BT 3DH5 2480 MHz
 Test Date: 2017-10-27
 Note:

Index 29

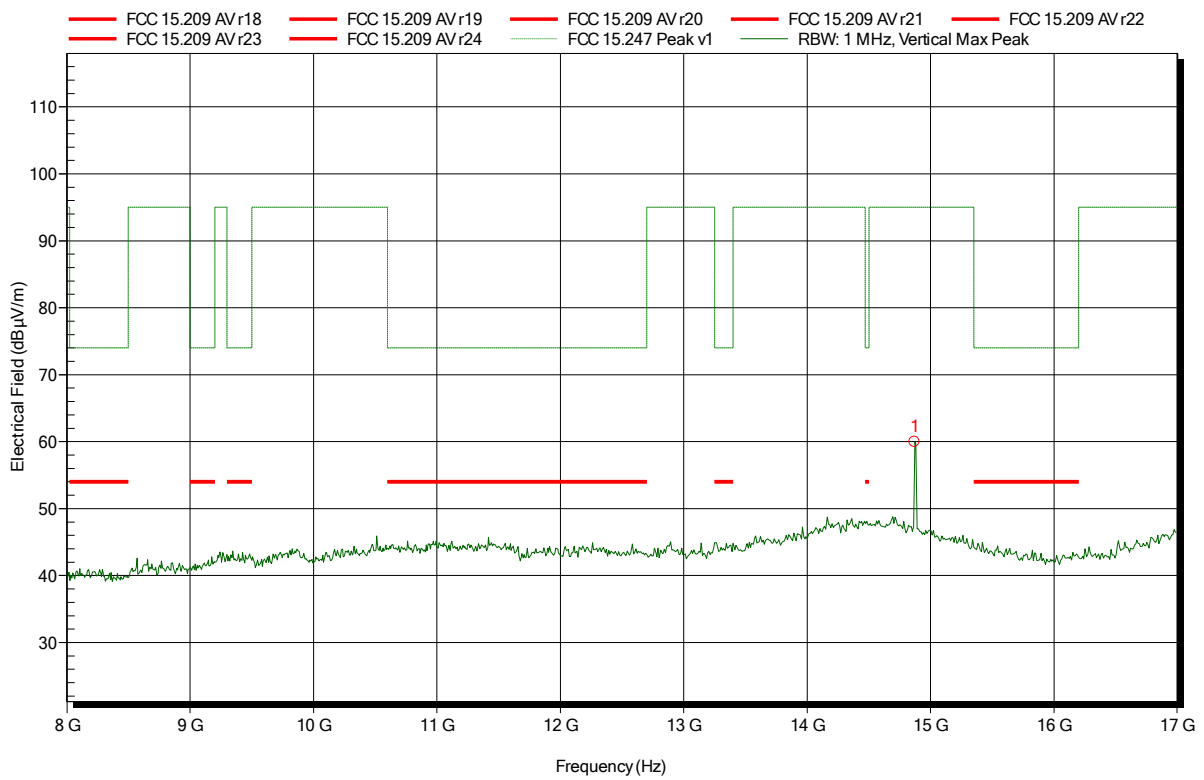

Frequency	Peak	Peak Limit	Peak Difference	Peak Status
14.87 GHz	59.97 dBµV/m	95 dBµV/m	-35.03 dB	Pass

Spurious emissions according to FCC 15.247

Project number: G0M-1707-6725

Applicant: Leica Geosystems AG
 EUT Name: External GNSS Antenna
 Model: GG04 plus
 Test Site: Eurofins Product Service GmbH
 Operator: Sebastian Suckow
 Test Conditions: Tnom: 23°C, Vnom: 12 VDC
 Antenna: Amplifier Research AT 4560, Horizontal
 Measurement distance: 1 m converted to 3m
 Mode: TX; BT 3DH5 2480 MHz
 Test Date: 2017-10-27
 Note:

Index 4

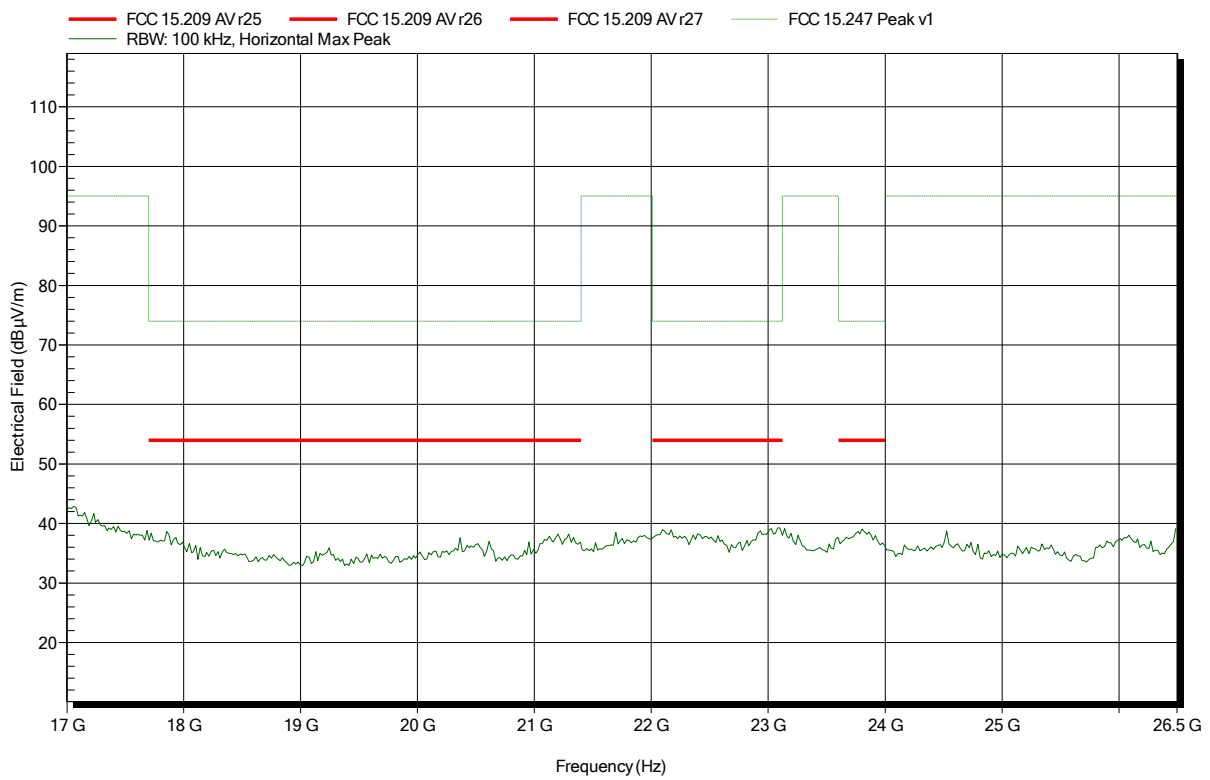

Spurious emissions according to FCC 15.247

Project number: G0M-1707-6725

Applicant: Leica Geosystems AG
 EUT Name: External GNSS Antenna
 Model: GG04 plus
 Test Site: Eurofins Product Service GmbH
 Operator: Sebastian Suckow
 Test Conditions: Tnom: 23°C, Vnom: 12 VDC
 Antenna: Amplifier Research AT 4560, Vertical
 Measurement distance: 1 m converted to 3m
 Mode: TX; BT 3DH5 2480 MHz
 Test Date: 2017-10-27
 Note:

Index 3

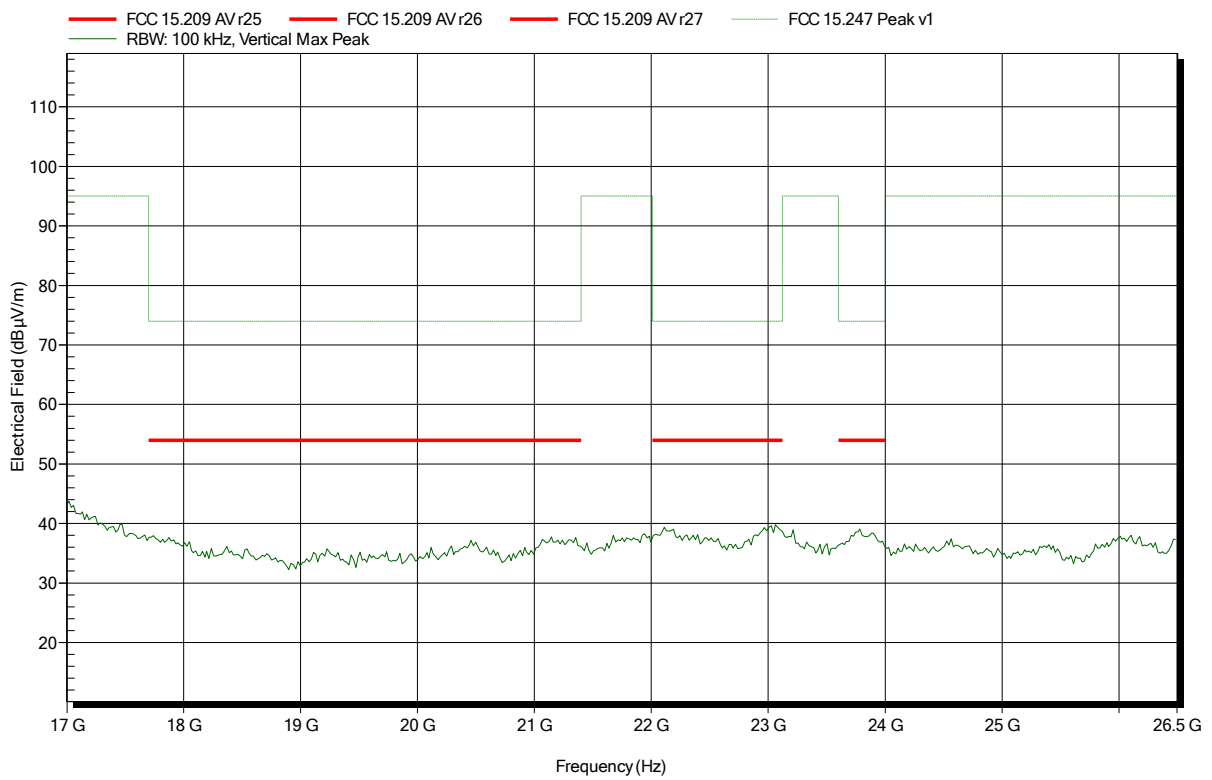

ANNEX B Receiver spurious emissions

Spurious emissions according to FCC 15.247

Project number: G0M-1707-6725

Applicant:	Leica Geosystems AG
EUT Name:	External GNSS Antenna
Model:	GG04 plus
Test Site:	Eurofins Product Service GmbH
Operator:	Mr. Suckow
Test Conditions:	Tnom: 22°C, Vnom: 12 VDC
Antenna:	Rohde & Schwarz HK 116, Horizontal
Measurement distance:	3 m
Mode:	RX; BT Scan Mode
Test Date:	2017-10-30
Note:	

Index 15

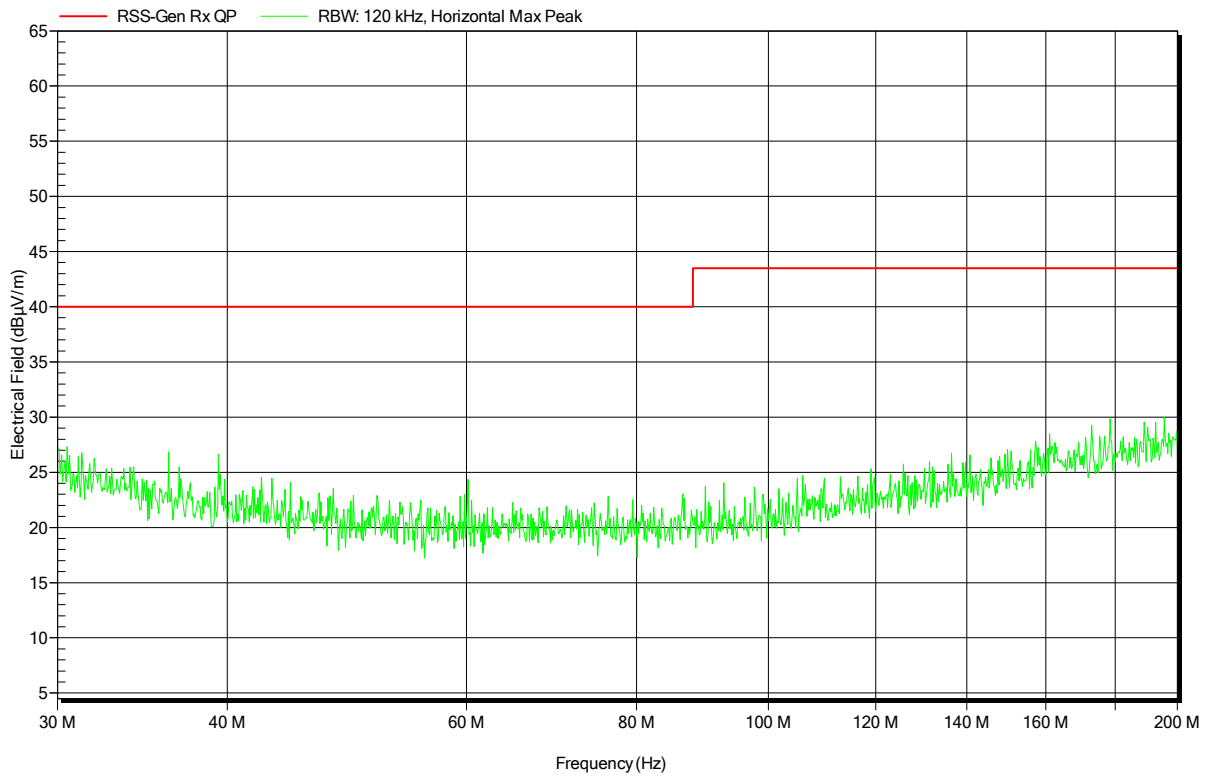

Spurious emissions according to FCC 15.247

Project number: G0M-1707-6725

Applicant: Leica Geosystems AG
 EUT Name: External GNSS Antenna
 Model: GG04 plus
 Test Site: Eurofins Product Service GmbH
 Operator: Mr. Suckow
 Test Conditions: Tnom: 22°C, Vnom: 12 VDC
 Antenna: Rohde & Schwarz HK 116, Vertical
 Measurement distance: 3 m
 Mode: RX; BT Scan Mode
 Test Date: 2017-10-30
 Note:

Index 16

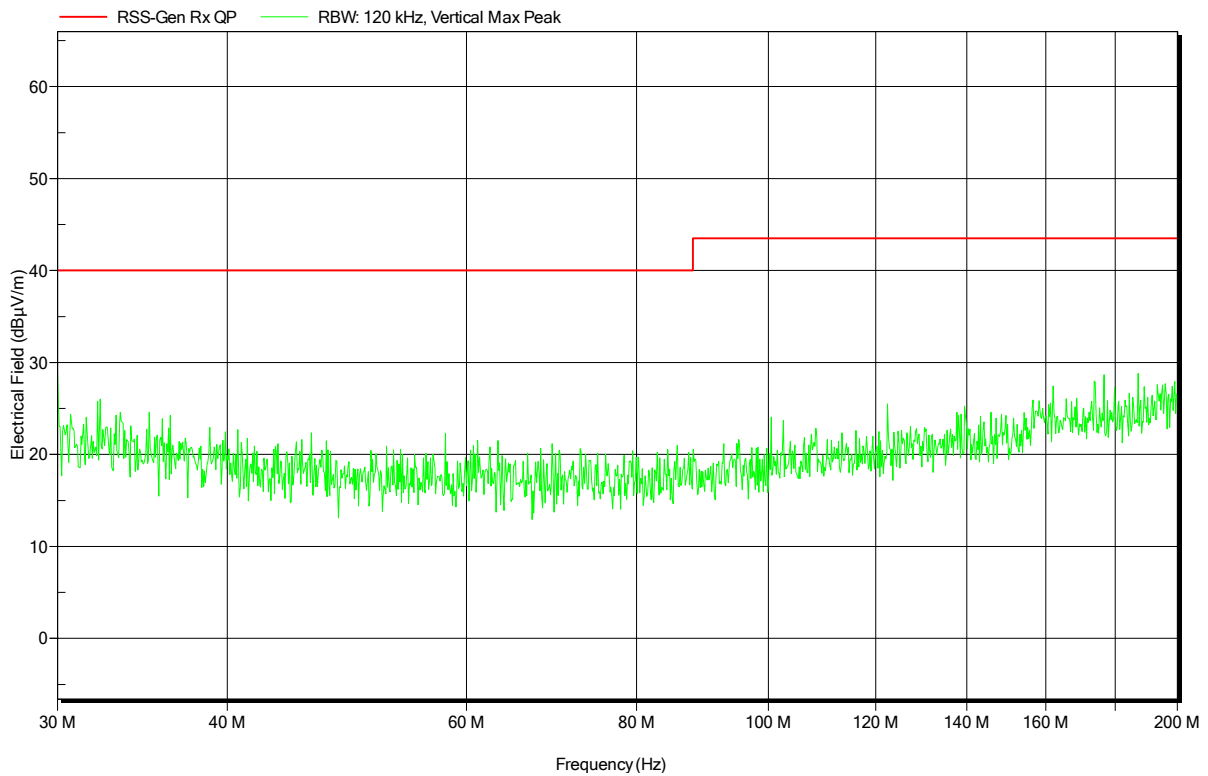

Spurious emissions according to FCC 15.247

Project number: G0M-1707-6725

Applicant: Leica Geosystems AG
 EUT Name: External GNSS Antenna
 Model: GG04 plus
 Test Site: Eurofins Product Service GmbH
 Operator: Mr. Suckow
 Test Conditions: Tnom: 22°C, Vnom: 12 VDC
 Antenna: Rohde & Schwarz HL 223, Horizontal
 Measurement distance: 3 m
 Mode: RX; BT Scan Mode
 Test Date: 2017-10-30
 Note:

Index 14

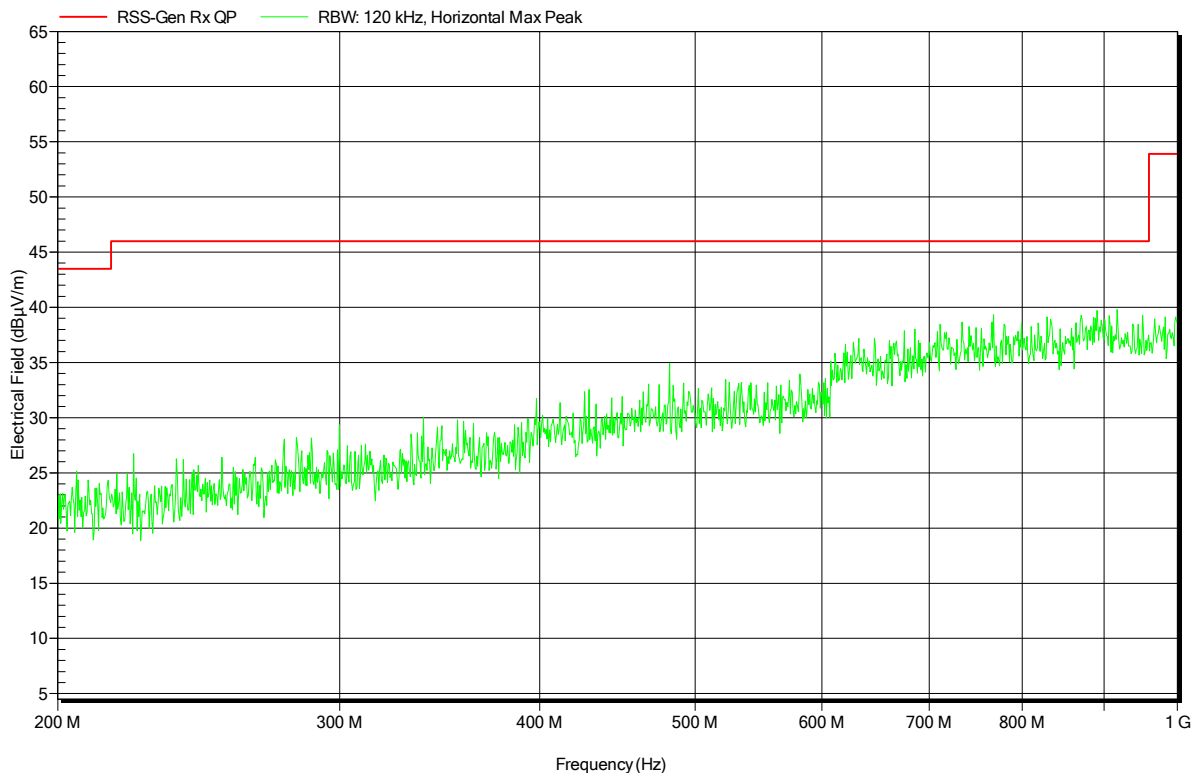

Spurious emissions according to FCC 15.247

Project number: G0M-1707-6725

Applicant: Leica Geosystems AG
 EUT Name: External GNSS Antenna
 Model: GG04 plus
 Test Site: Eurofins Product Service GmbH
 Operator: Mr. Suckow
 Test Conditions: Tnom: 22°C, Vnom: 12 VDC
 Antenna: Rohde & Schwarz HL 223, Vertical
 Measurement distance: 3 m
 Mode: RX; BT Scan Mode
 Test Date: 2017-10-30
 Note:

Index 13

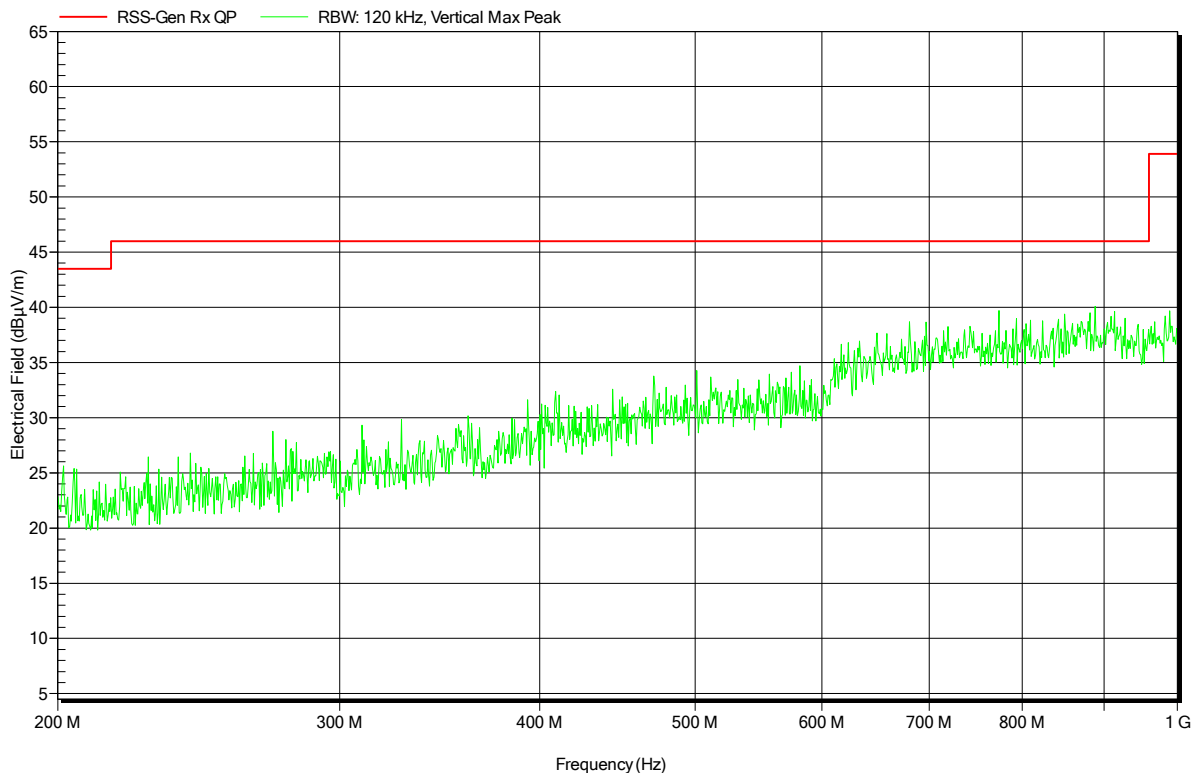

Spurious emissions according to FCC 15.247

Project number: G0M-1707-6725

Applicant: Leica Geosystems AG
 EUT Name: External GNSS Antenna
 Model: GG04 plus
 Test Site: Eurofins Product Service GmbH
 Operator: Sebastian Suckow
 Test Conditions: Tnom: 23°C, Vnom: 12 VDC
 Antenna: Schwarzbeck BBHA 9120D, Horizontal
 Measurement distance: 3 m
 Mode: RX; BT Scan Mode
 Test Date: 2017-10-27
 Note:

Index 33

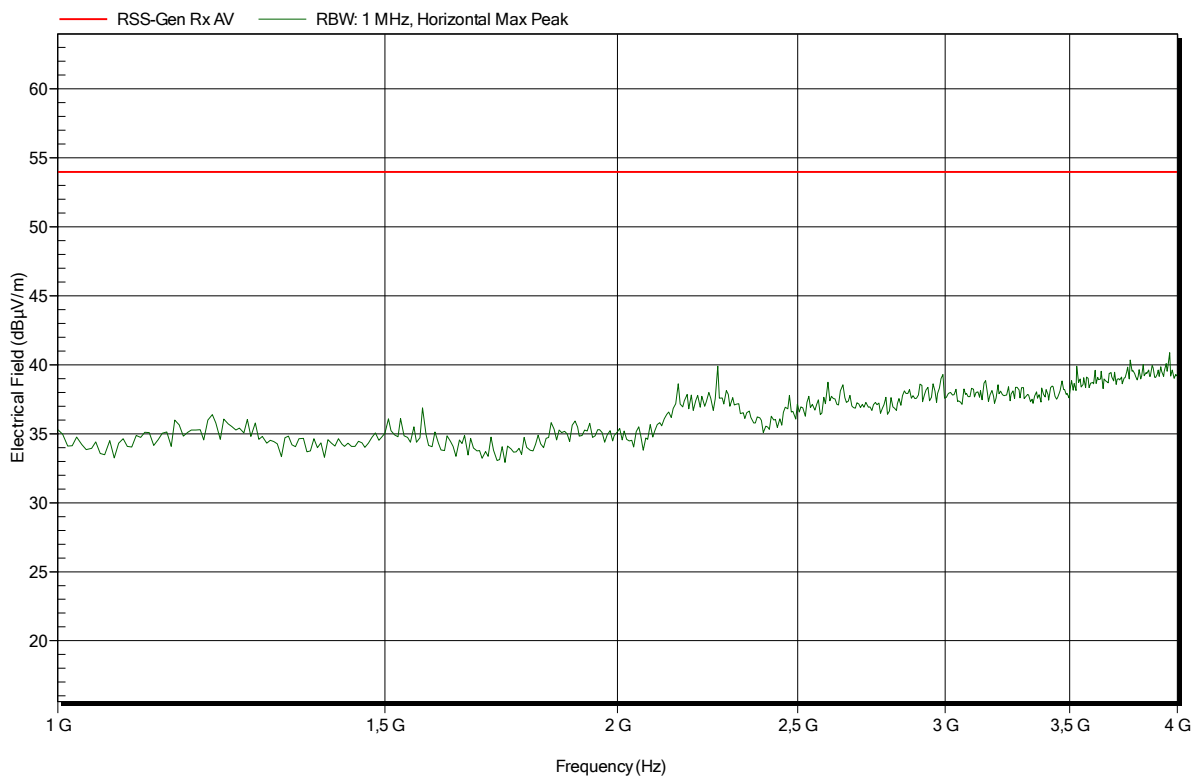

Spurious emissions according to FCC 15.247

Project number: G0M-1707-6725

Applicant: Leica Geosystems AG
 EUT Name: External GNSS Antenna
 Model: GG04 plus
 Test Site: Eurofins Product Service GmbH
 Operator: Sebastian Suckow
 Test Conditions: Tnom: 23°C, Vnom: 12 VDC
 Antenna: Schwarzbeck BBHA 9120D, Vertical
 Measurement distance: 3 m
 Mode: RX; BT Scan Mode
 Test Date: 2017-10-27
 Note:

Index 34

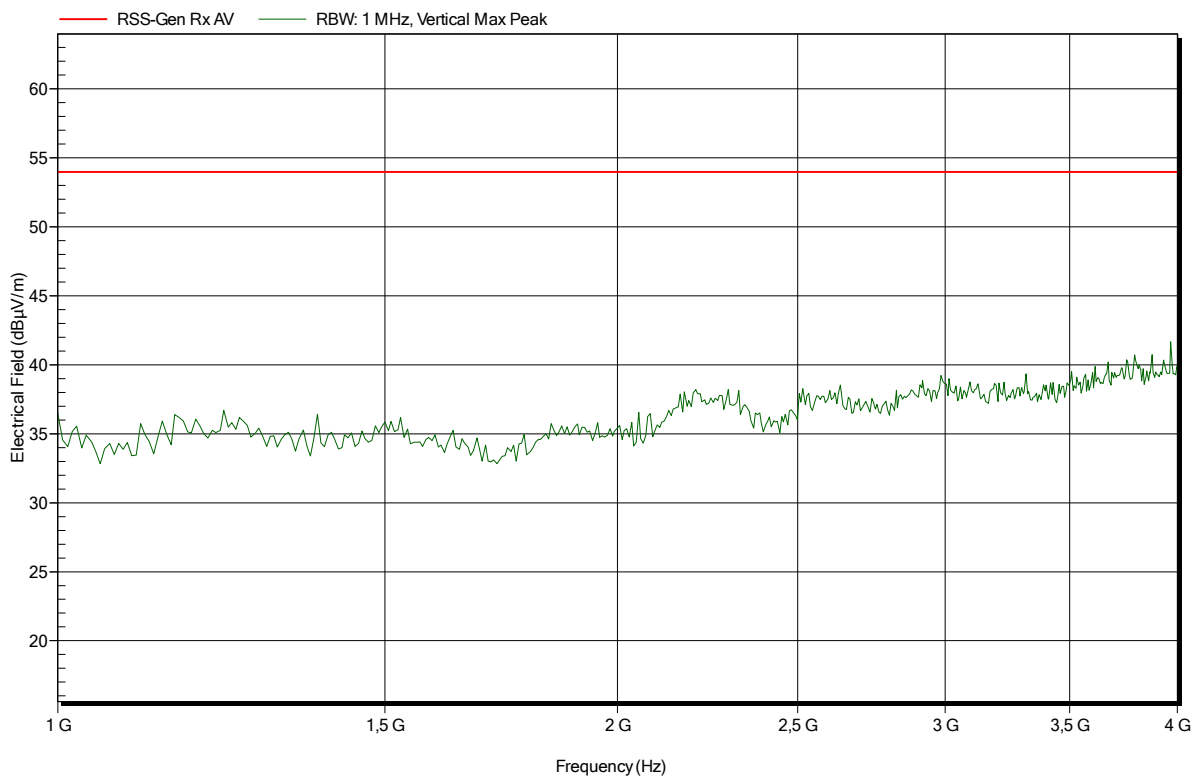

Spurious emissions according to FCC 15.247

Project number: G0M-1707-6725

Applicant: Leica Geosystems AG
 EUT Name: External GNSS Antenna
 Model: GG04 plus
 Test Site: Eurofins Product Service GmbH
 Operator: Sebastian Suckow
 Test Conditions: Tnom: 23°C, Vnom: 12 VDC
 Antenna: Schwarzbeck BBHA 9120D, Horizontal
 Measurement distance: 3 m
 Mode: RX; BT Scan Mode
 Test Date: 2017-10-27
 Note:

Index 32

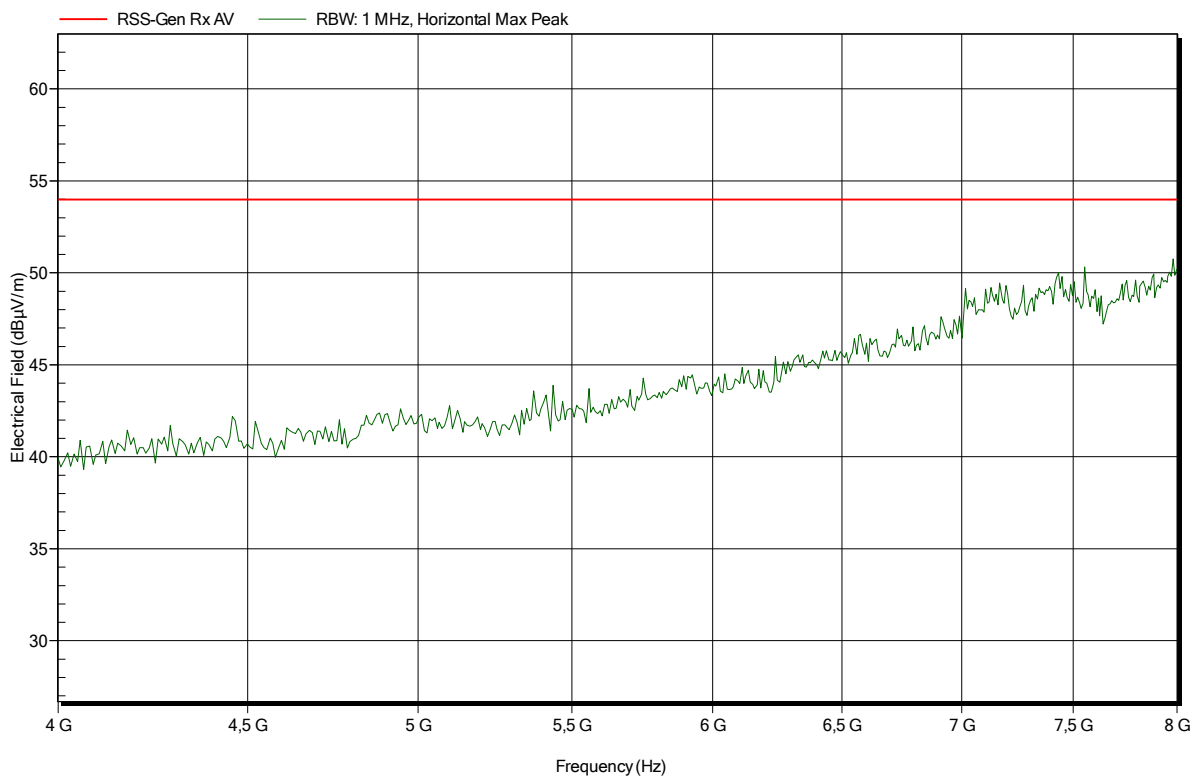

Spurious emissions according to FCC 15.247

Project number: G0M-1707-6725

Applicant: Leica Geosystems AG
 EUT Name: External GNSS Antenna
 Model: GG04 plus
 Test Site: Eurofins Product Service GmbH
 Operator: Sebastian Suckow
 Test Conditions: Tnom: 23°C, Vnom: 12 VDC
 Antenna: Schwarzbeck BBHA 9120D, Vertical
 Measurement distance: 3 m
 Mode: RX; BT Scan Mode
 Test Date: 2017-10-27
 Note:

Index 35

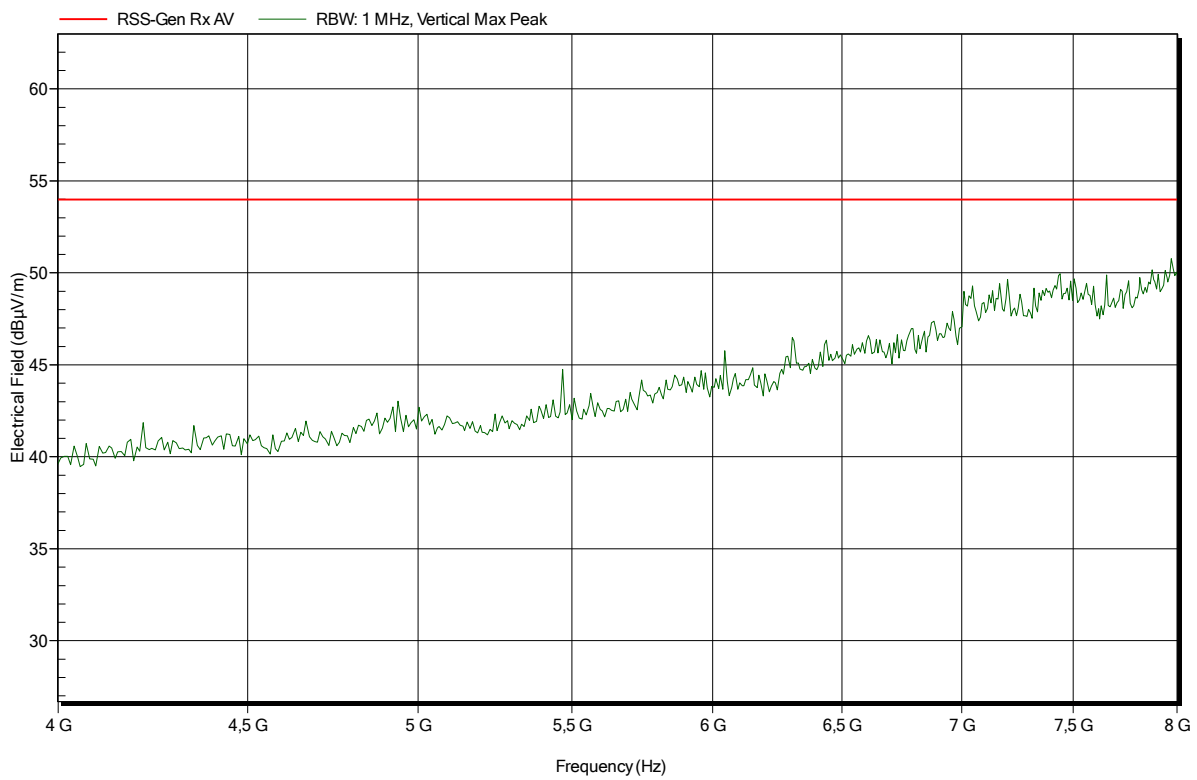

Spurious emissions according to FCC 15.247

Project number: G0M-1707-6725

Applicant: Leica Geosystems AG
 EUT Name: External GNSS Antenna
 Model: GG04 plus
 Test Site: Eurofins Product Service GmbH
 Operator: Sebastian Suckow
 Test Conditions: Tnom: 23°C, Vnom: 12 VDC
 Antenna: Schwarzbeck BBHA 9120D, Horizontal
 Measurement distance: 1 m converted to 3m
 Mode: RX; BT Scan Mode
 Test Date: 2017-10-27
 Note:

Index 31

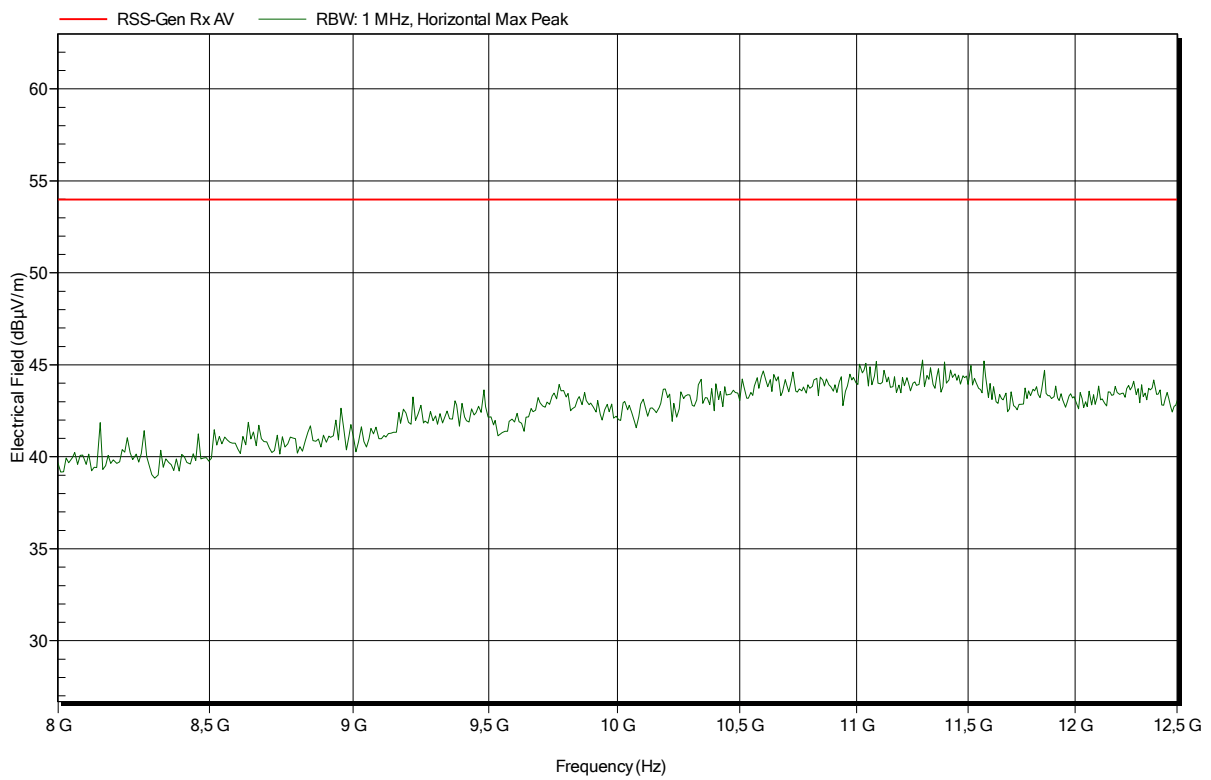

Spurious emissions according to FCC 15.247

Project number: G0M-1707-6725

Applicant: Leica Geosystems AG
 EUT Name: External GNSS Antenna
 Model: GG04 plus
 Test Site: Eurofins Product Service GmbH
 Operator: Sebastian Suckow
 Test Conditions: Tnom: 23°C, Vnom: 12 VDC
 Antenna: Schwarzbeck BBHA 9120D, Vertical
 Measurement distance: 1 m converted to 3m
 Mode: RX; BT Scan Mode
 Test Date: 2017-10-27
 Note:

Index 30

