



TAOGLAS®

Leica
Geosystems



Datasheet

High Precision GNSS Board

Taoglas / Leica Part No:
MAT.200A / 956186 A

Description

PCB With Multi-band GNSS Antenna and 2x Wi-Fi Antennas

Features:

- 1 * GPDF5012.A Multi-Band L1/L2/L5 GNSS Antenna
 - 2 * WLA.01 Wi-Fi Single Band at 2.4 GHz
- Dims: 102.5mm * 102.5mm * 18.6mm
- 3 * 1.37mm SMA cable with U.FL connectors
- RoHS & Reach Compliant

1.	Introduction	2
2.	Specification	3
3.	Antenna Characteristics	6
4.	Active Characteristics	14
5.	Radiation Patterns	16
6.	Mechanical Drawings	47
7.	Packaging	49
<hr/>		
	Changelog	49

Taoglas makes no warranties based on the accuracy or completeness of the contents of this document and reserves the right to make changes to specifications and product descriptions at any time without notice. Taoglas reserves all rights to this document and the information contained herein. Reproduction, use or disclosure to third parties without express permission is strictly prohibited.



1. Introduction

The MAT.200A is a populated PCB manufactured by Taoglas for Leica. It is intended to be used inside the Leica Crocodile device.

The PCB includes one [GPDF5012.A](#) high-precision GNSS antenna as well as two [WLA.01](#) Wi-Fi antennas. This PCB has been designed and tested for use inside an enclosure, as supplied by Leica. All tests shown within this datasheet were performed with the PCB inserted inside the device enclosure.



Figure 1 MAT.200A PCB Supplied to Leica



Figure 2 Enclosure For the MAT.200A

2. Specification

GNSS Frequency Bands					
GPS	L1 1575.42 MHz	L2 1227.6 MHz	L5 1176.45 MHz		
	■	■	■		
GLONASS	G1 1602 MHz	G2 1248 MHz	G3 1207 MHz		
	■	■	■		
Galileo	E1 1575.24 MHz	E5a 1176.45 MHz	E5b 1201.5 MHz	E6 1278.75 MHz	
	■	■	■	□	
Bei Dou	B1C 1575.42 MHz	B1I 1561 MHz	B2a 1176.45 MHz	B2b 1207.14 MHz	B3 1268.52 MHz
	■	■	■	■	□
QZSS (Regional)	L1 1575.42 MHz	L2C 1227.6 MHz	L5 1176.45 MHz	L6 1278.75e6	
	■	■	■	□	
IRNSS (Regional)	L5 1176.45 MHz				
	■				
SBAS	L1/E1/B1 1575.42 MHz	L5/B2a/E5a 1176.45 MHz	G1 1602 MHz	G2 1248 MHz	G3 1207 MHz
	■	■	■	■	■

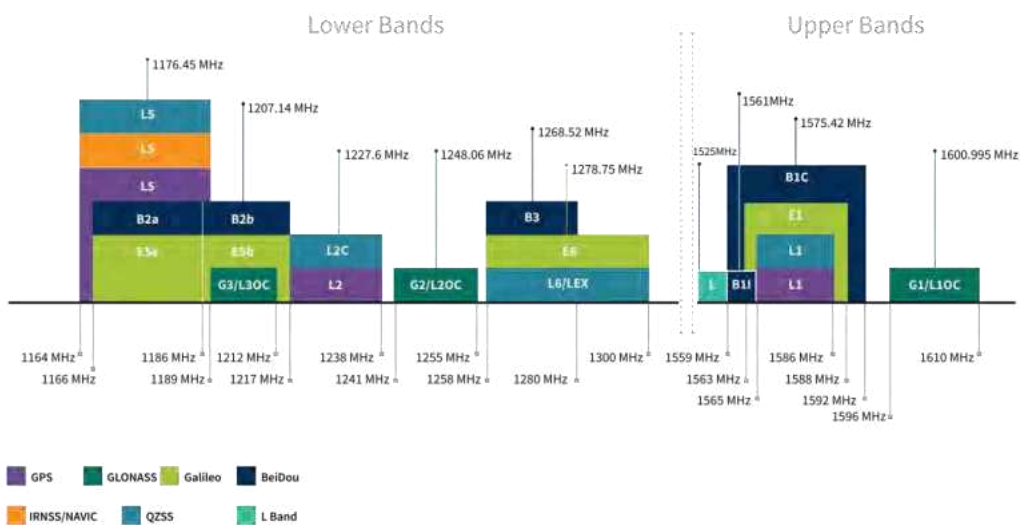

GNSS Bands and Constellations

GNSS Electrical							
Frequency (MHz)	1176.45	1201.55	1227.6	1248	1561	1575.42	1603
Axial Ratio (dB) at Zenith	0.96	0.74	1.37	1.6	0.78	0.52	0.29
Axial Ratio (dB) from Zenith to 30° Elevation for Phi = 0	1	0.67	1.41	1.64	0.82	0.45	0.27
Axial Ratio (dB) from Zenith to 30° Elevation for Phi = 90°	0.98	0.65	1.39	1.61	0.79	0.41	0.29
PCO (cm)	1.03	0.95	0.99	1.16	1.5	1.42	1.38
PCV (cm)	0.52	0.46	0.45	0.49	0.52	0.57	0.47
Group Delay Mean (ns)	18.74	19.02	15.88	16.17	50.26	37.18	41.19
Group Delay Variation (ns)	5	4	3	2	9	26	5
Polarization	RHCP						
Impedance	50 Ω						
Cable	3x 1.37mm cable						
Connector	U.FL						

LNA and Filter Electrical Properties (Typical Values)							
Frequency (MHz)	1176.45	1201.55	1227.6	1248	1561	1575.42	1603
Gain@3.0V (dB)	28.05	29.72	28.66	28.65	31.2	31.75	31.3
Noise@3.0V (dB)	3.05	2.55	2.42	2.33	2.4	2.18	2.05
Power consumption@3.0V (mA)	17						

Total Specification (Through Antenna, SAW Filter, LNA, Power Dividers & Hybrid Couplers)							
Frequency (MHz)	1176.45	1201.55	1227.6	1248	1561	1575.42	1603
Gain@3V (dBi)	24.86	28.94	27.5	25.4	28.7	29.15	28.78

Wi-Fi Electrical								
Band	Frequency (MHz)	Antenna	Efficiency (%)	Average Gain (dB)	Peak Gain (dBi)	Impedance	Polarization	Radiation Pattern
Wi-Fi – 2.4 GHz	2400-2500	Wi-Fi1	33.4	-4.77	-0.12	50 Ω	Linear	Omni
		Wi-Fi2	35.0	-4.56	0.08			

Mechanical

Dimensions	102.5mm x 102.5mm x 18.6mm
Weight	130g
Material	FR-4 PCB

Environmental

Operation Temperature	-40°C to 85°C
Storage Temperature	-40°C to 85°C
Relative Humidity	Non-condensing 65°C 95% RH
RoHs & REACH Compliant	Yes

3. Antenna Characteristics

3.1 Test Setup

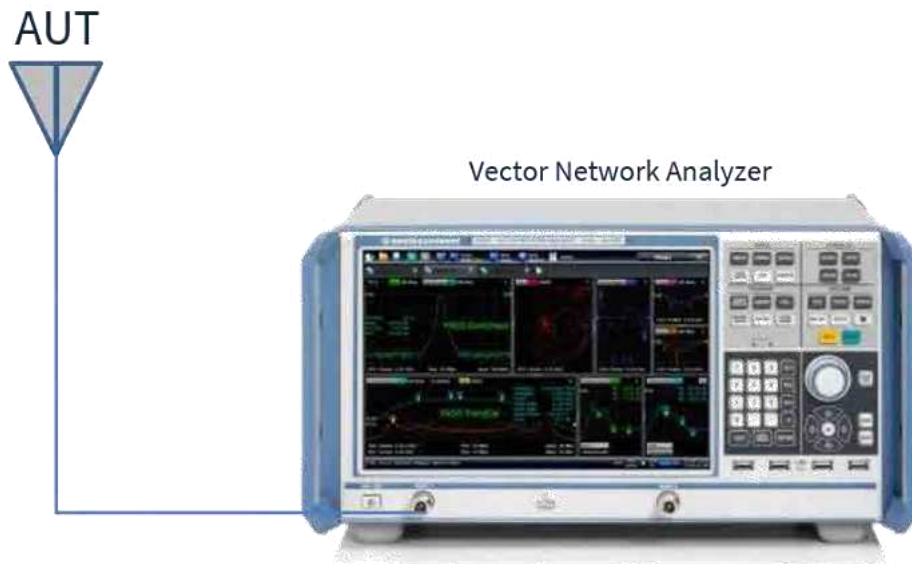
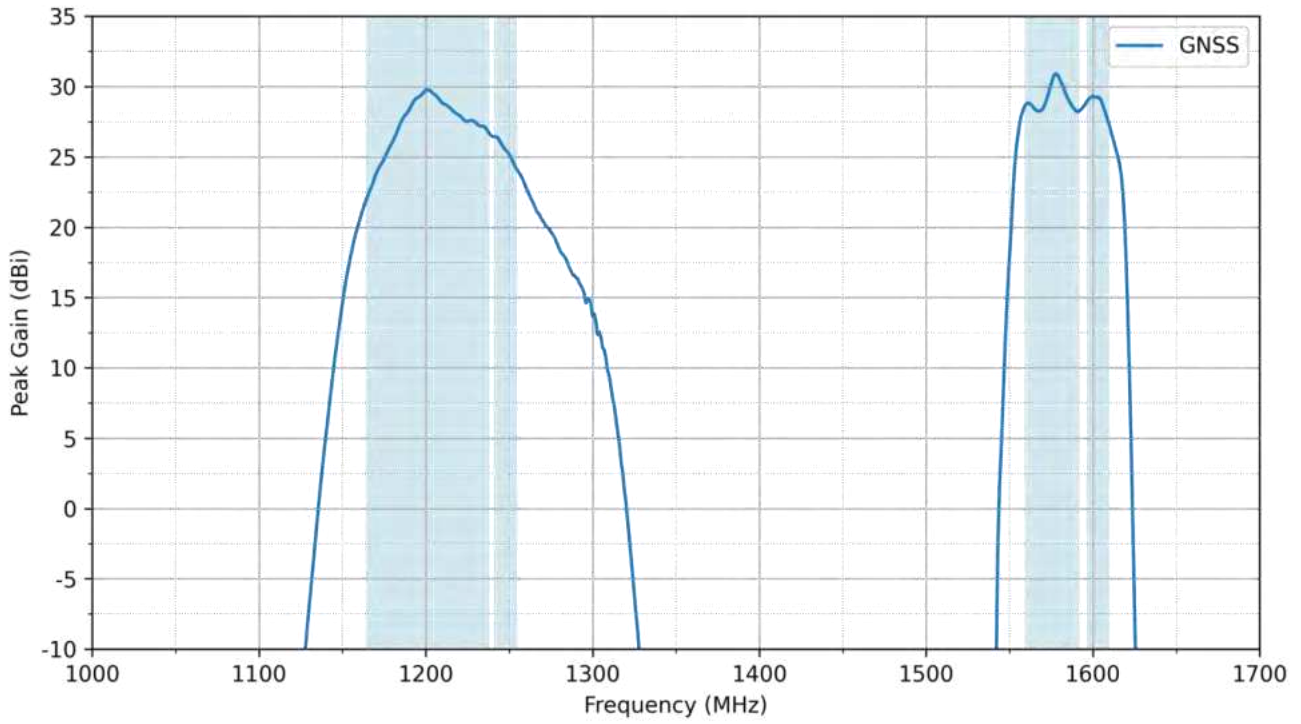
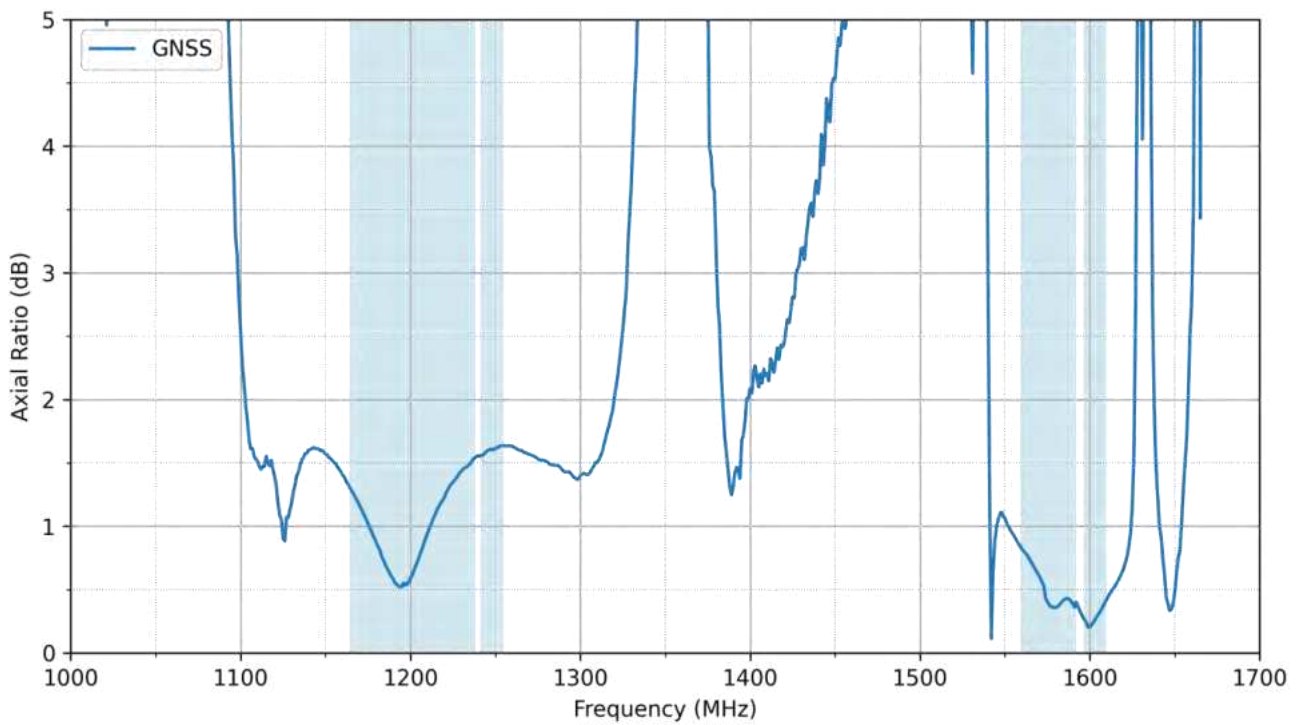

Figure 3 Test Setup for VNA Measurements

3.2 GNSS - Peak Gain



3.3 GNSS - Axial Ratio



3.4 GNSS - Axial Ratio vs Angle for Phi=0°

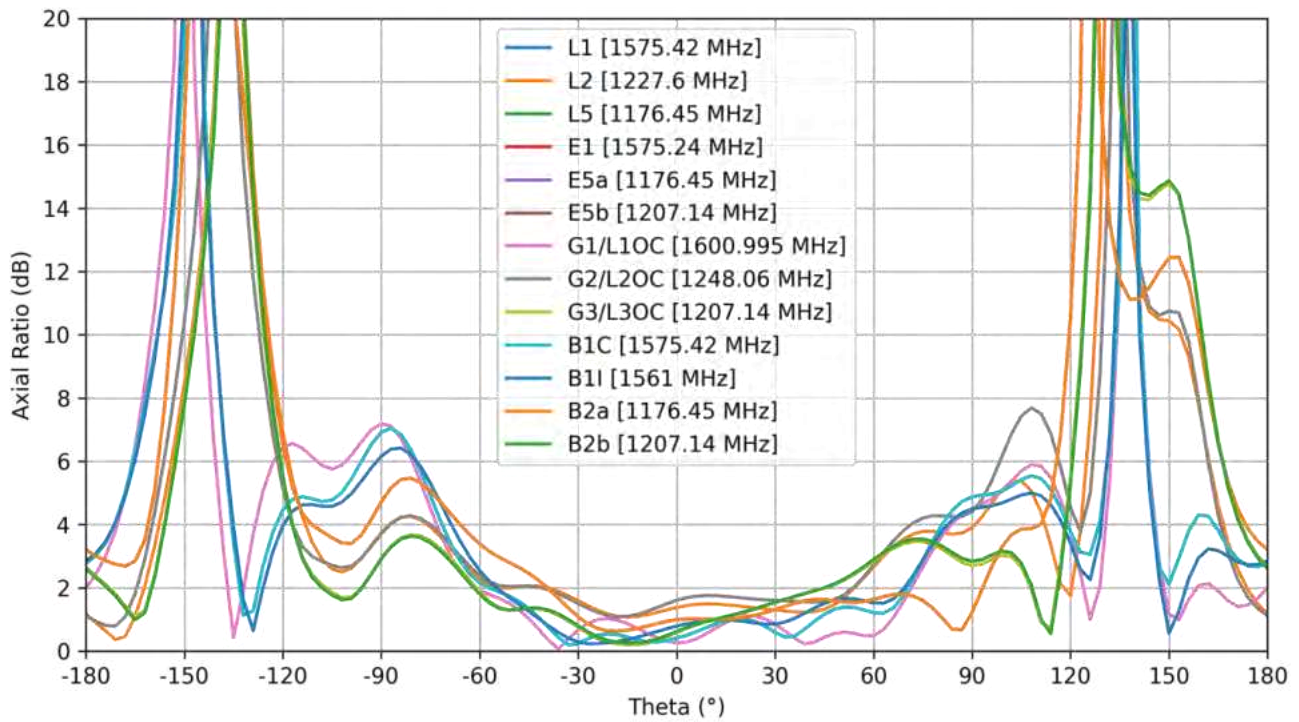

3.5 GNSS - Axial Ratio vs Angle for Phi=90°

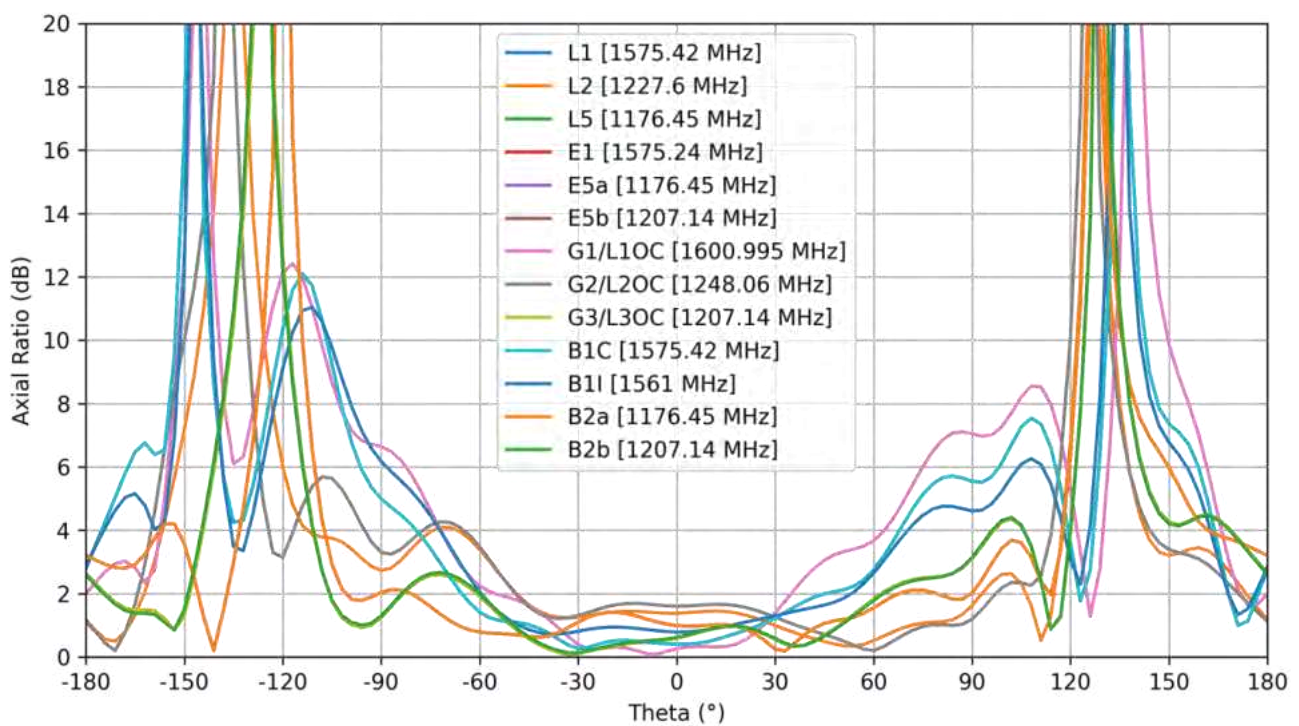

3.6 GNSS - PCO

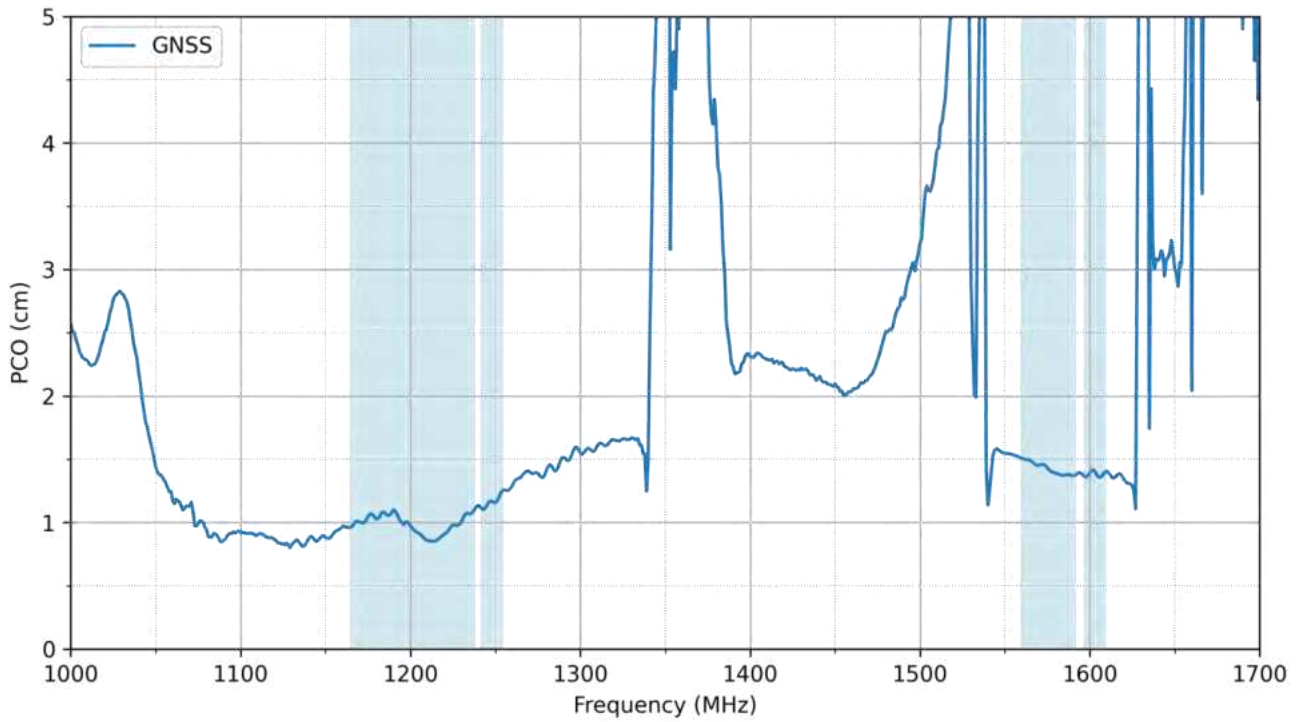

3.7 GNSS - PCV

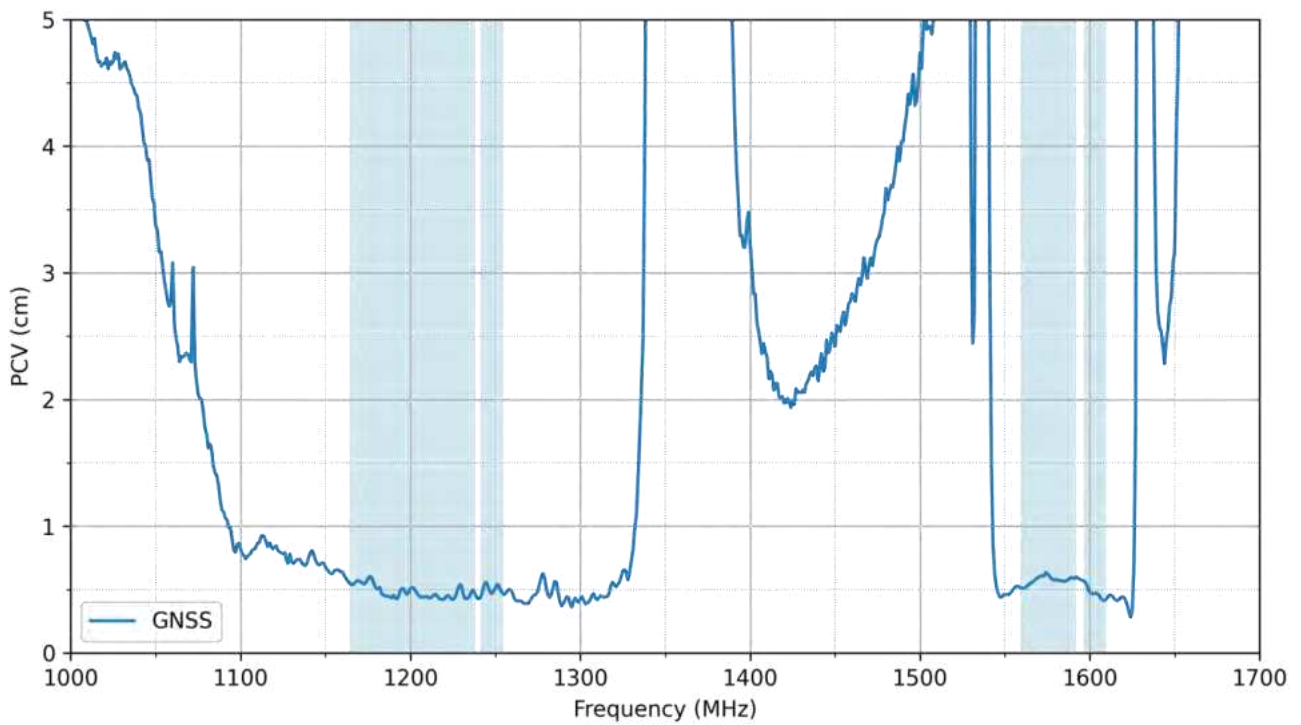

3.8 GNSS - Group Delay

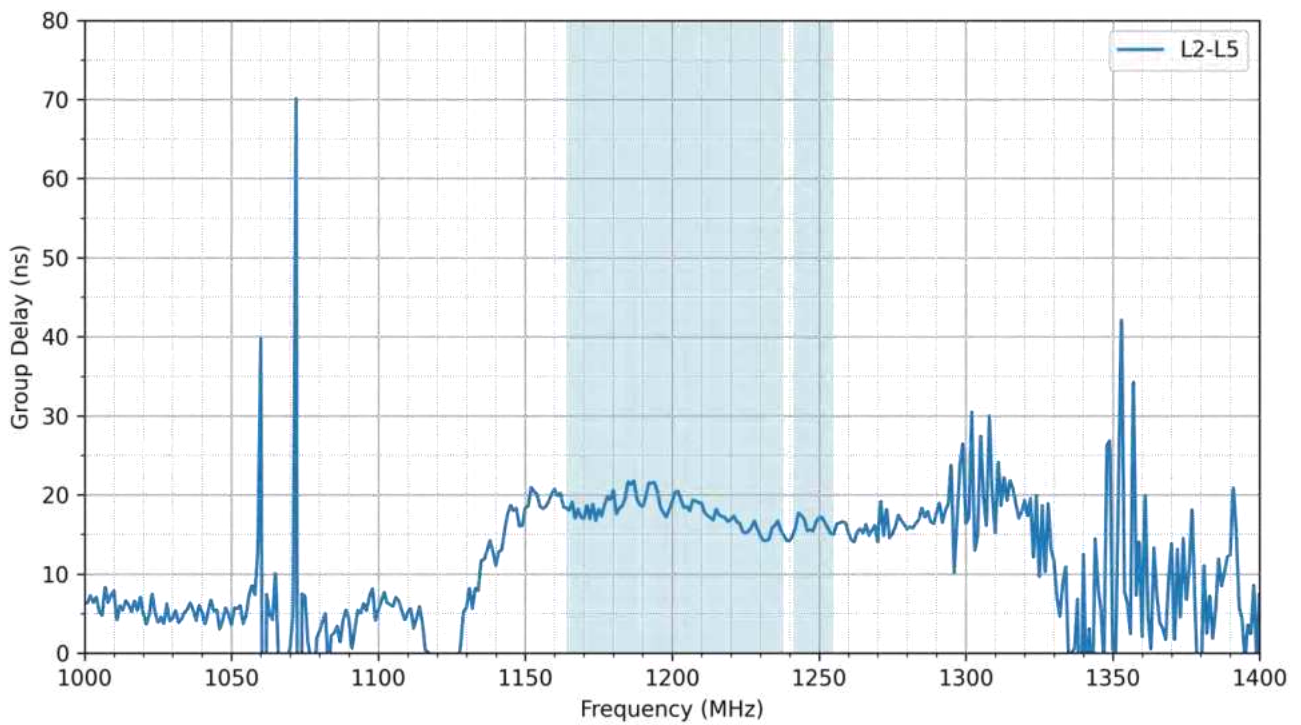
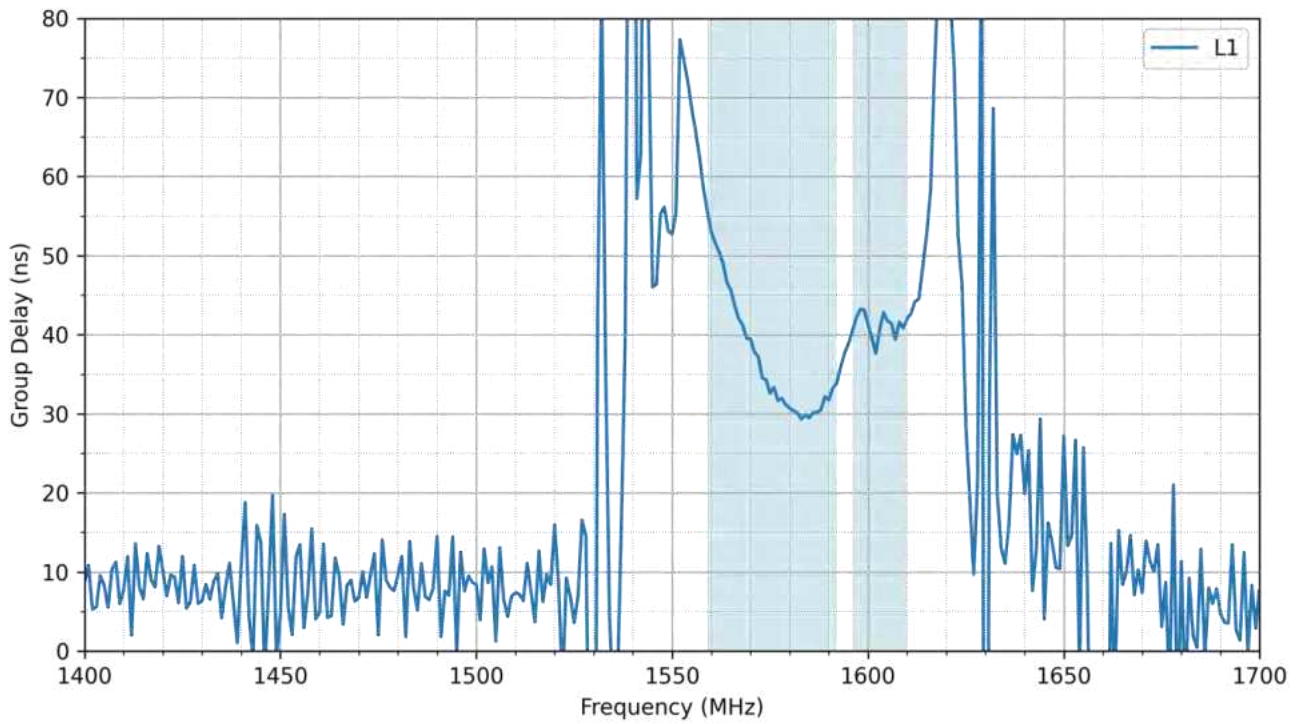

3.9 Wi-Fi - Return Loss

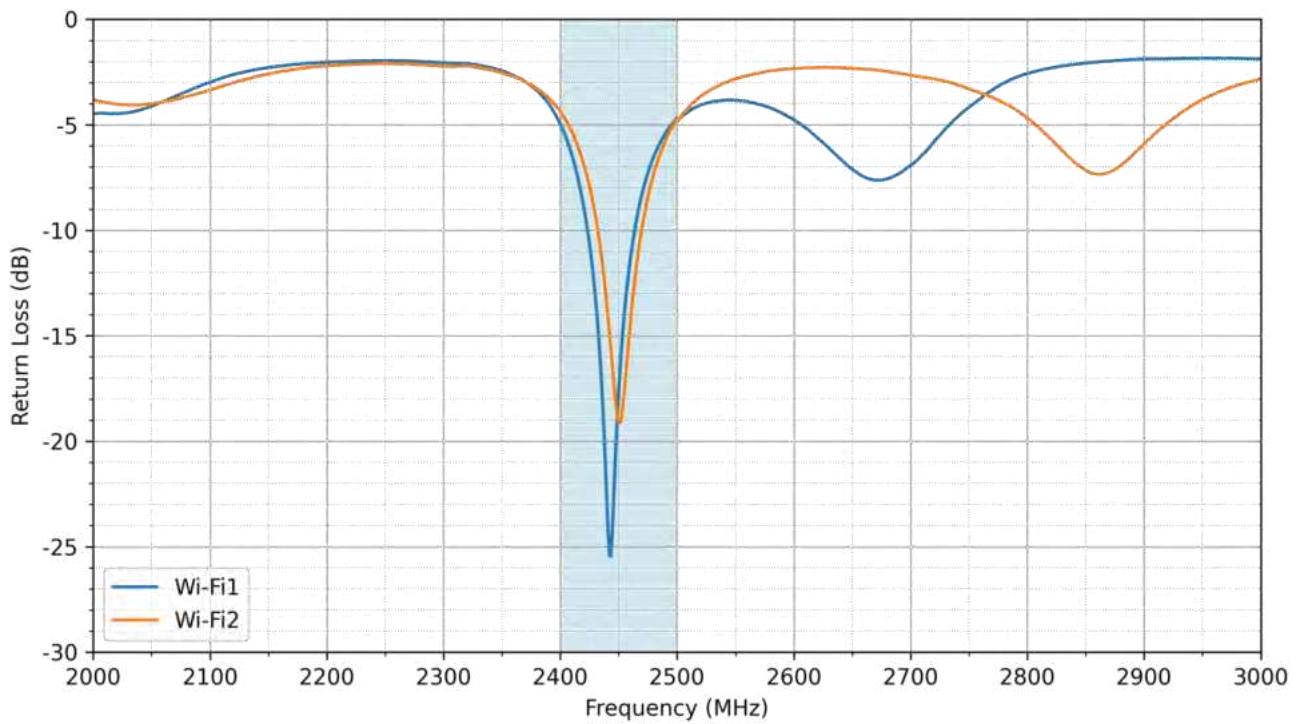

3.10 Wi-Fi - Isolation

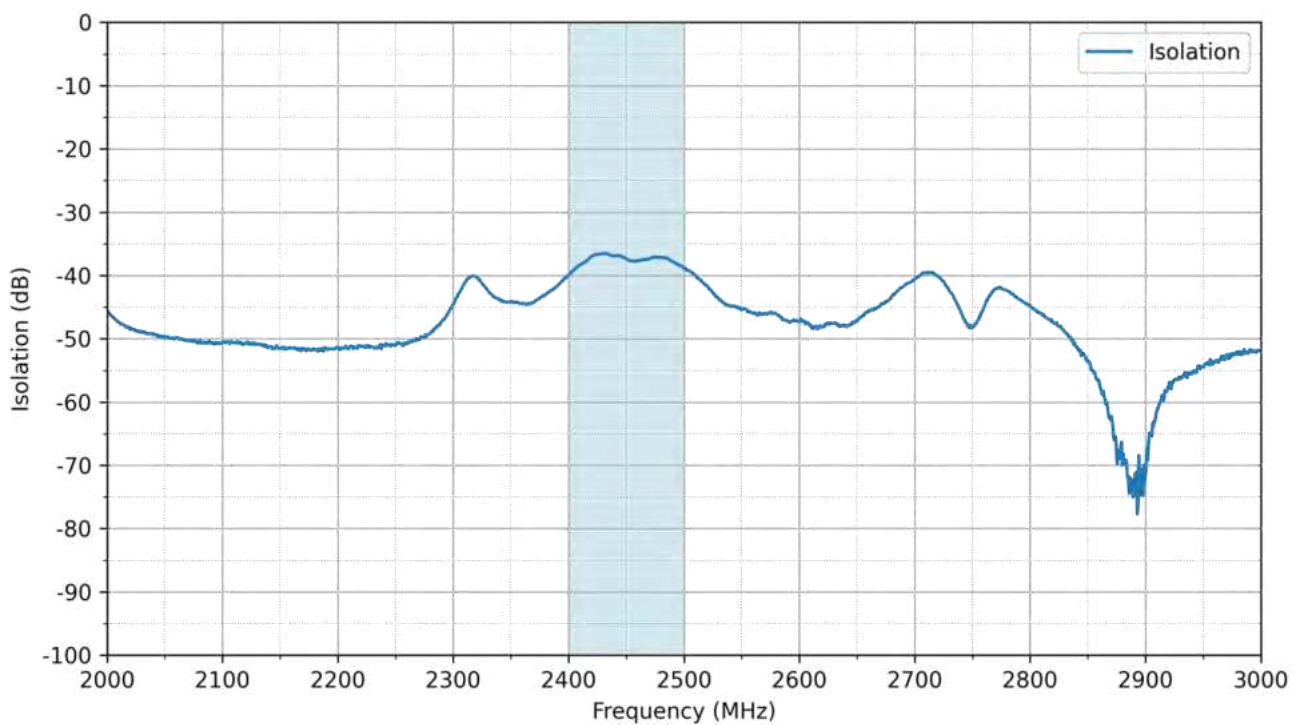

3.11 Wi-Fi - Efficiency

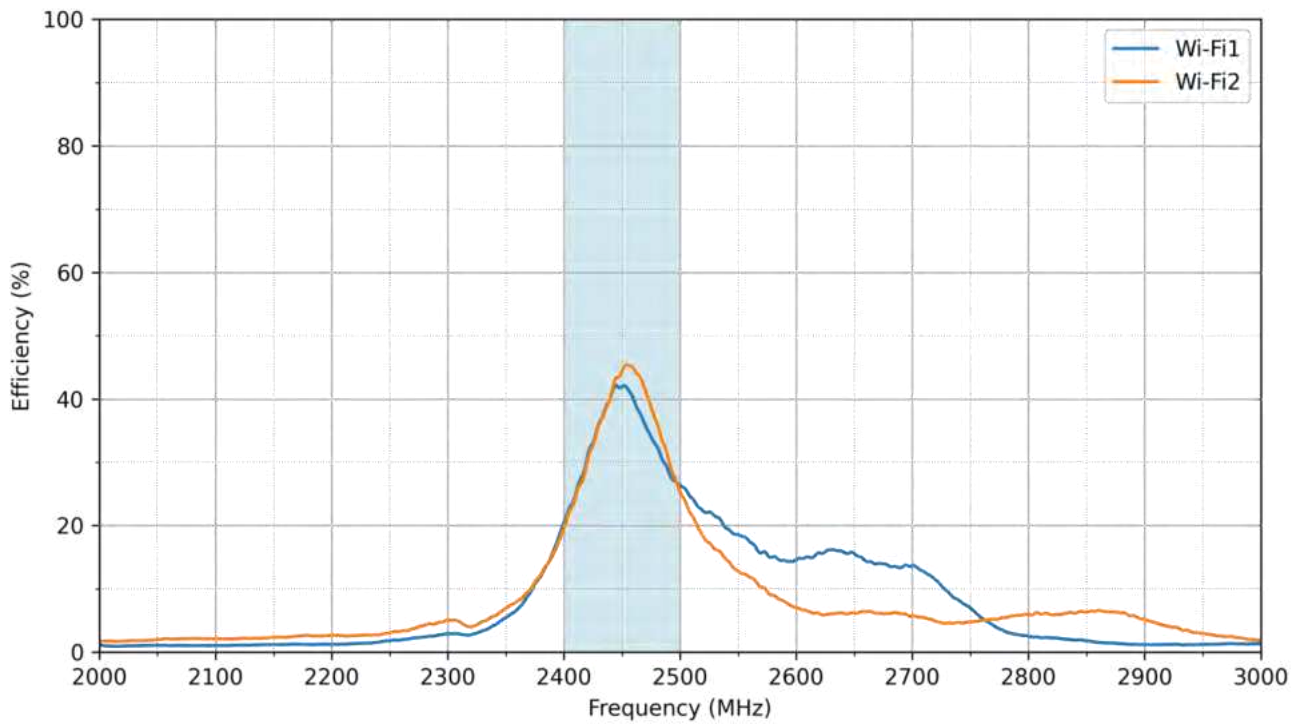

3.12 Wi-Fi - Average Gain

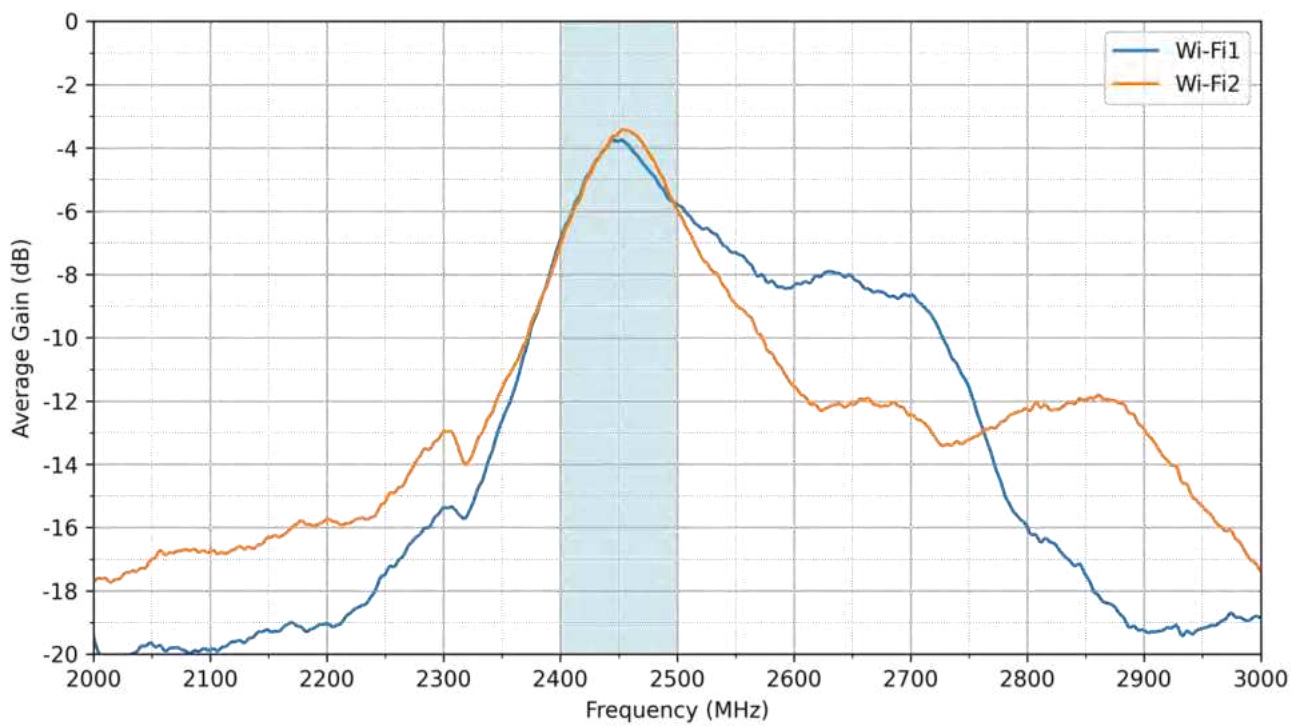

3.13 Wi-Fi - Peak Gain

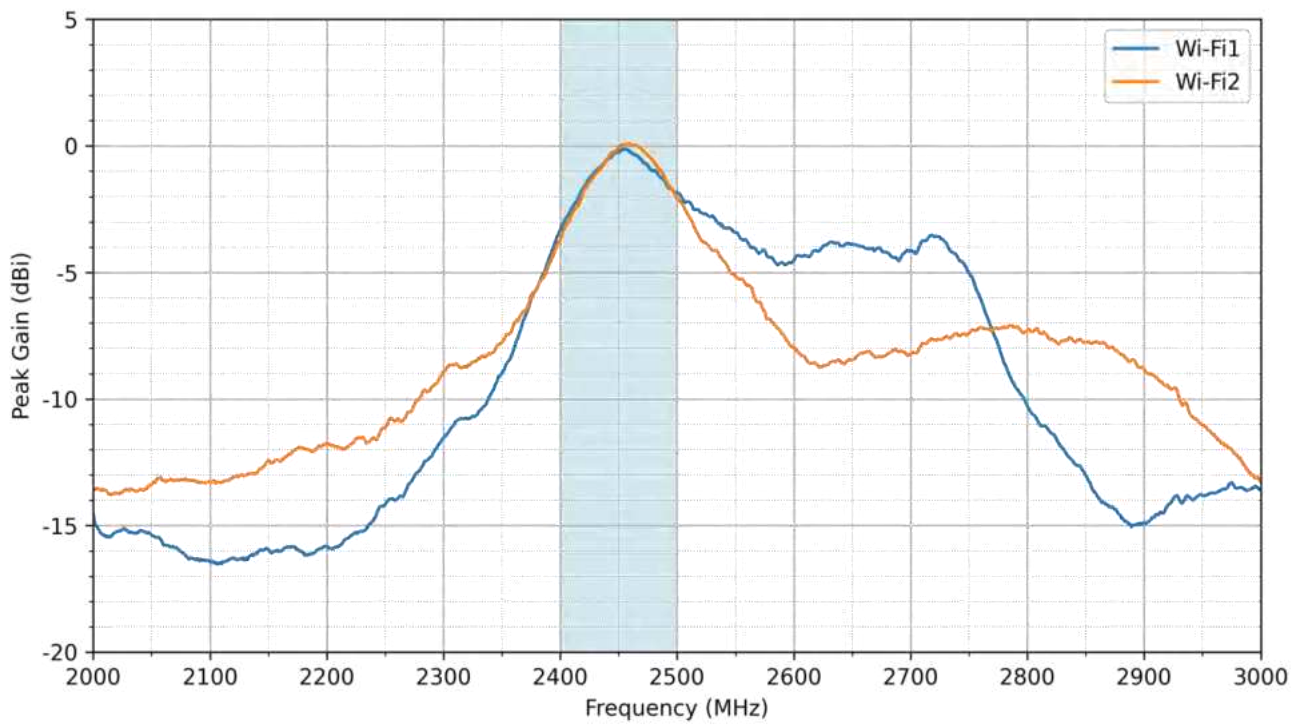

4. Active Characteristics

4.1 Active Circuit Gain

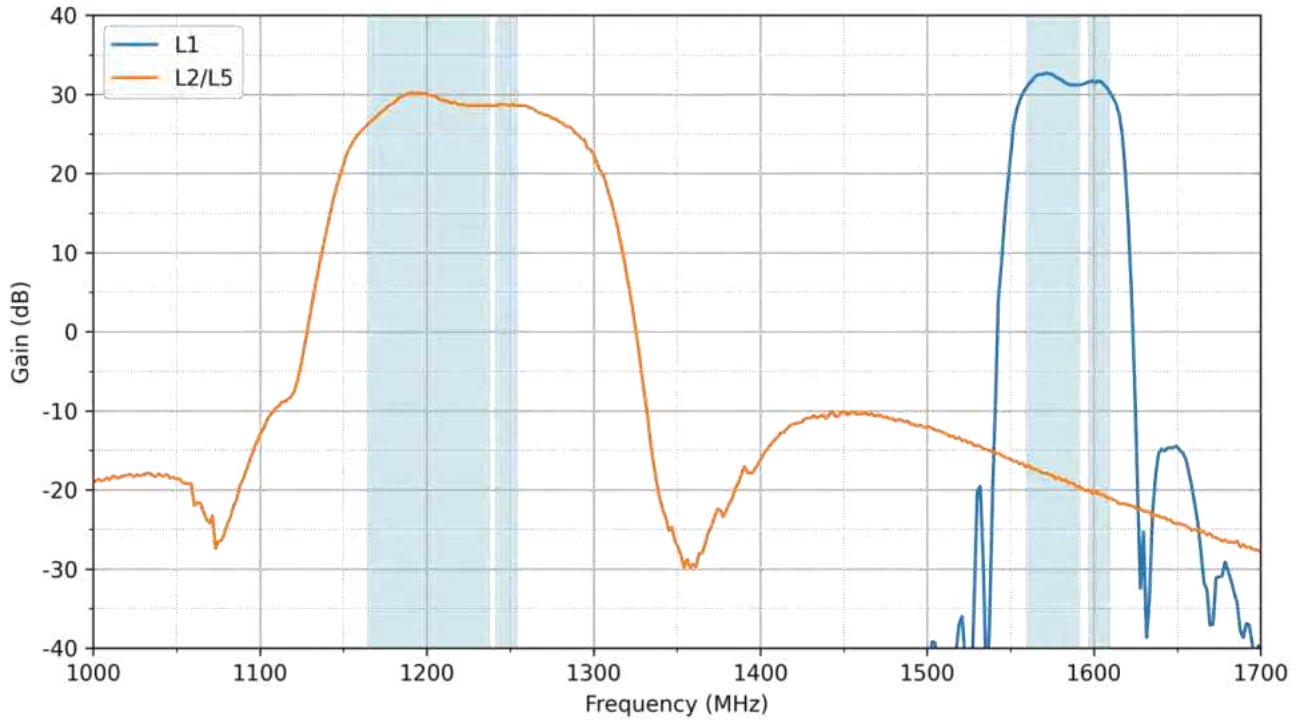

4.2 Active Circuit Out of Band Attenuation

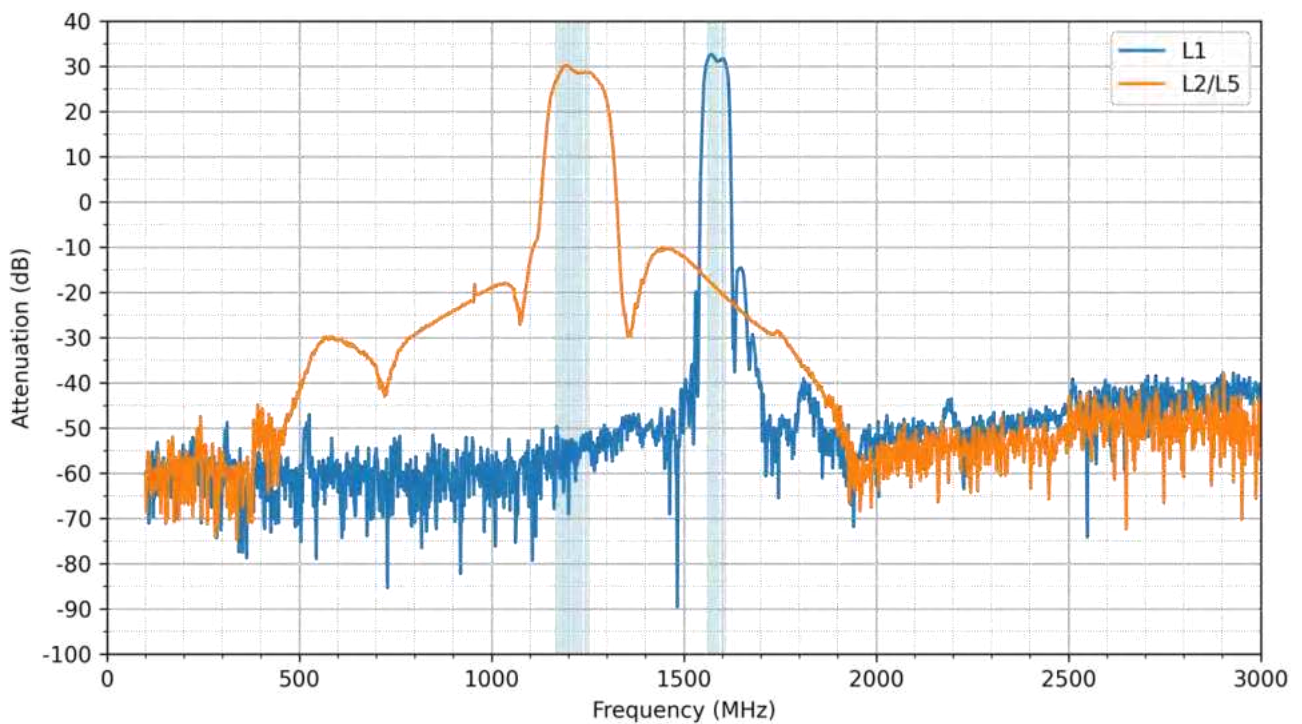

4.3 Active Circuit Noise Figure

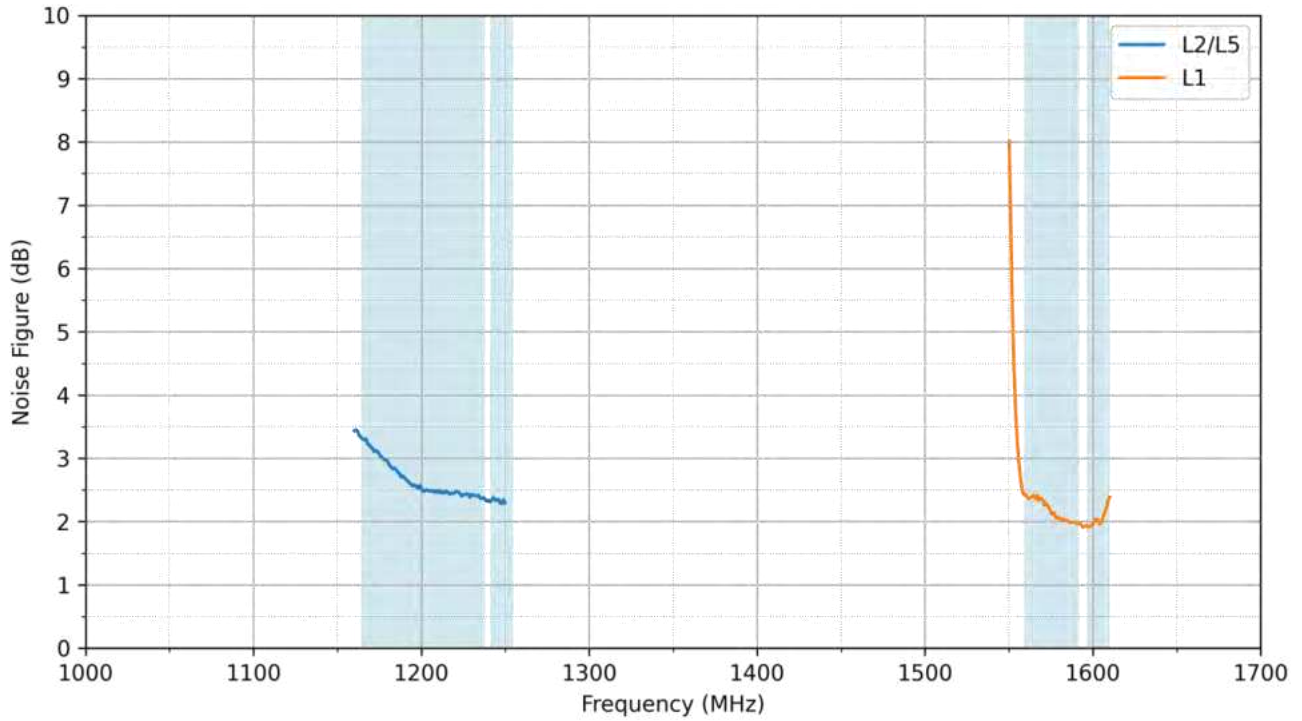

5. Radiation Patterns

5.1 Test Setup

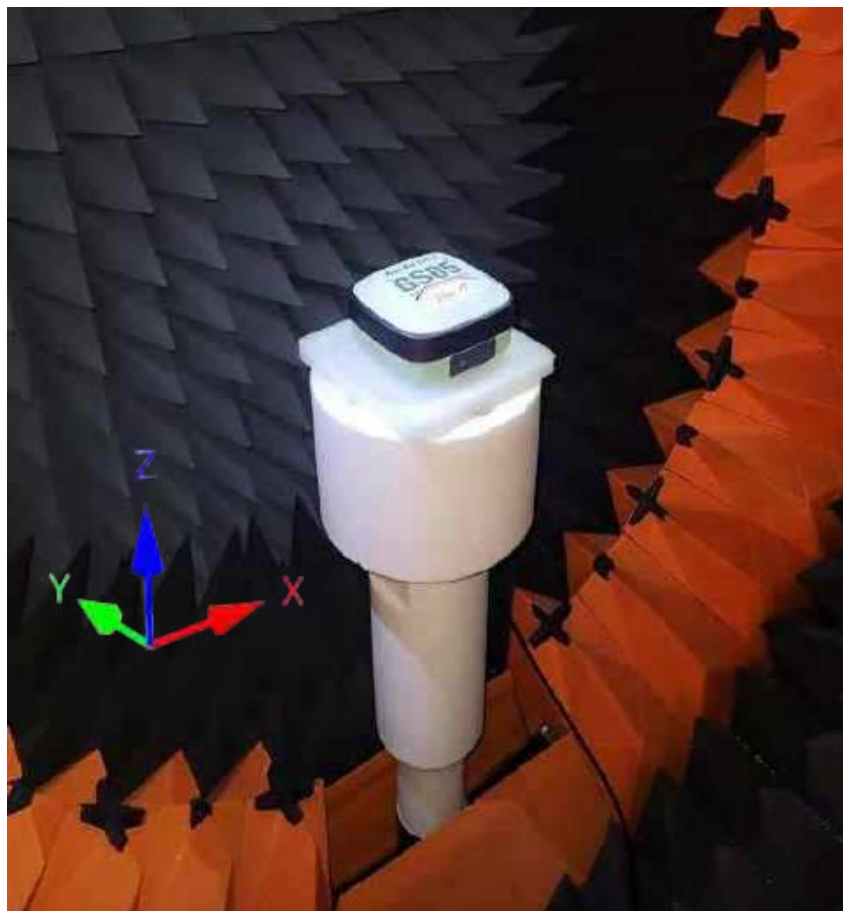
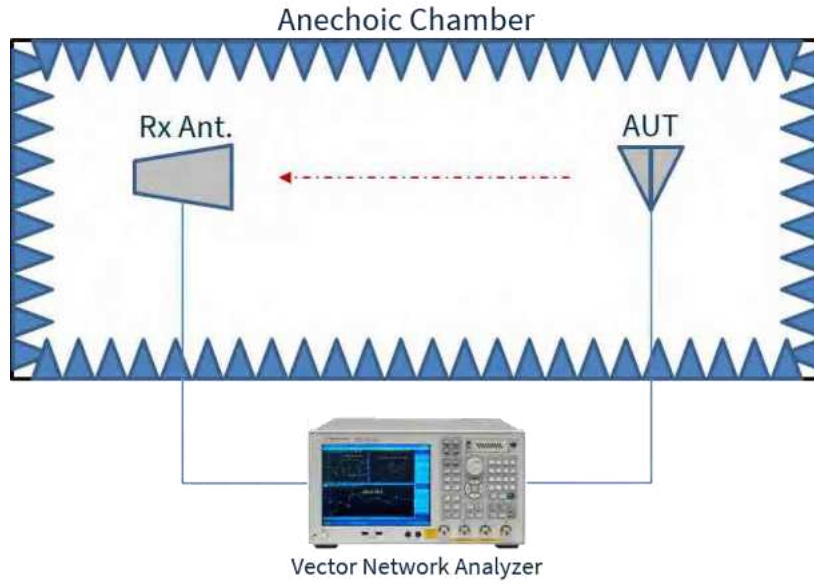
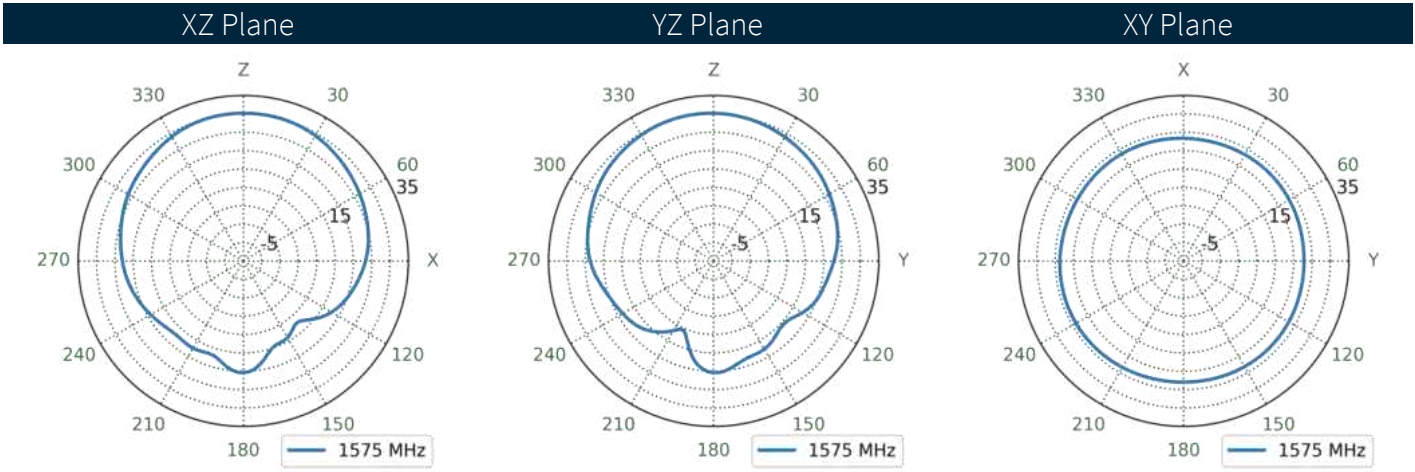
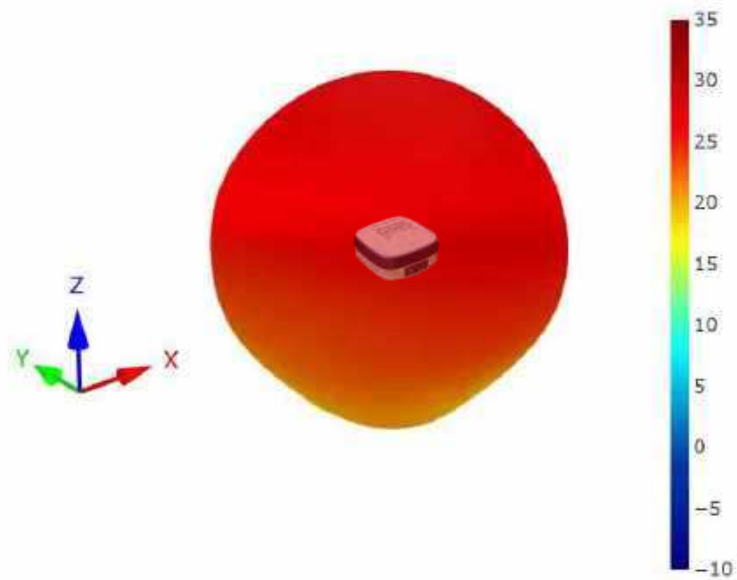
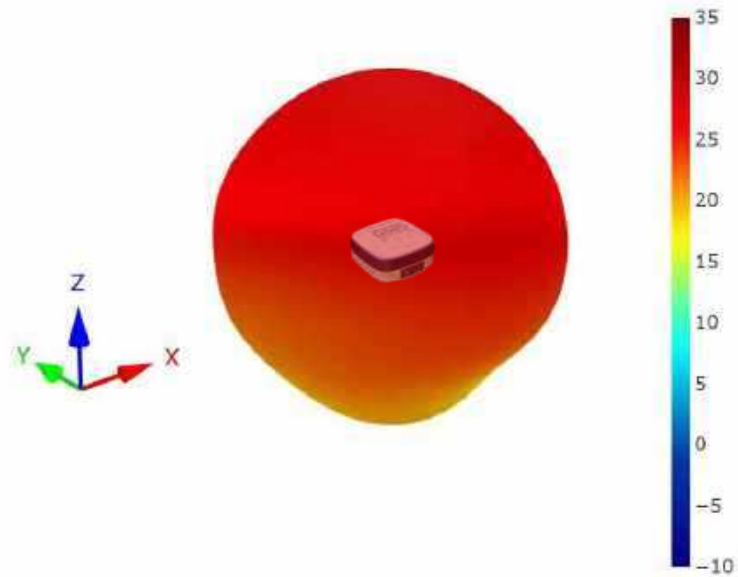

Figure 4 Test Setup for Chamber Measurements

5.2 GNSS Patterns at 1575 MHz [L1/E1/B1C]



5.3 GNSS Patterns at 1575 MHz for GRHP [L1/E1/B1C]



XZ Plane YZ Plane XY Plane

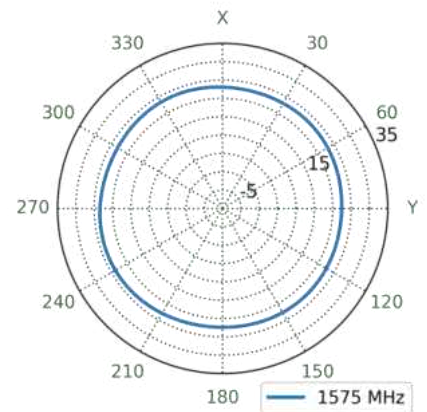
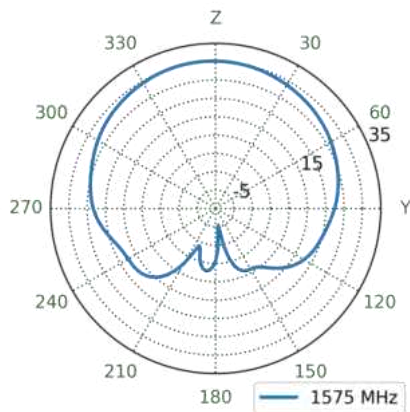
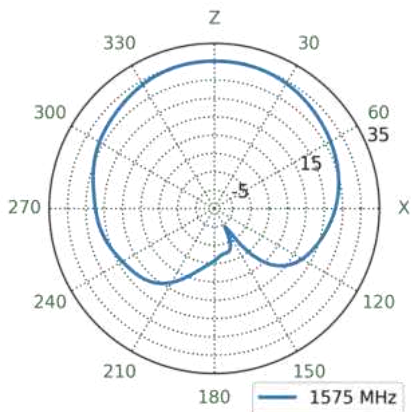

5.4 GNSS Patterns at 1575 MHz for GLHP [L1/E1/B1C]

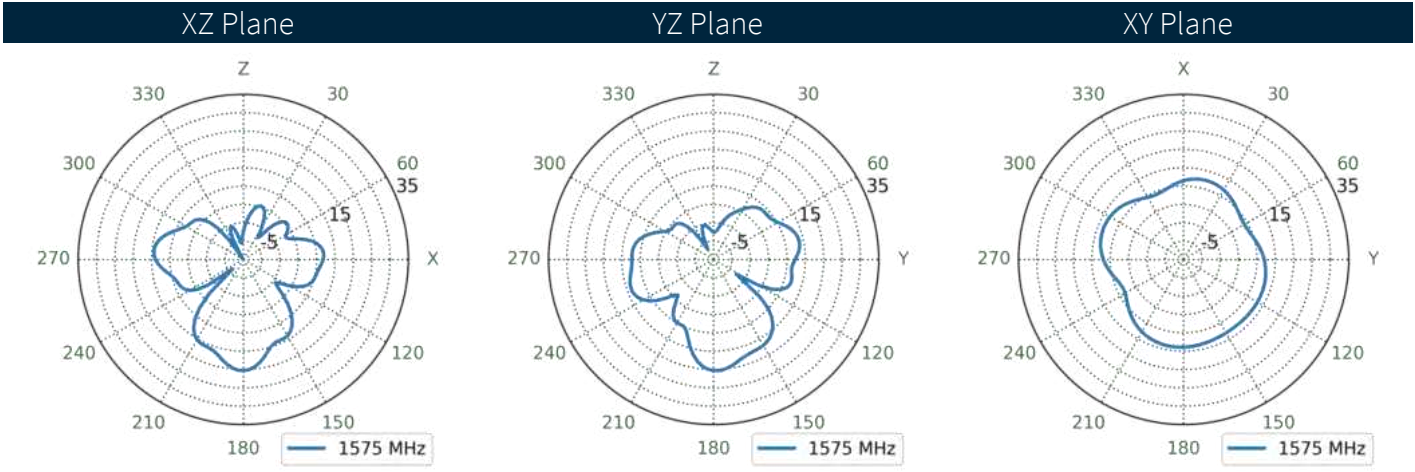
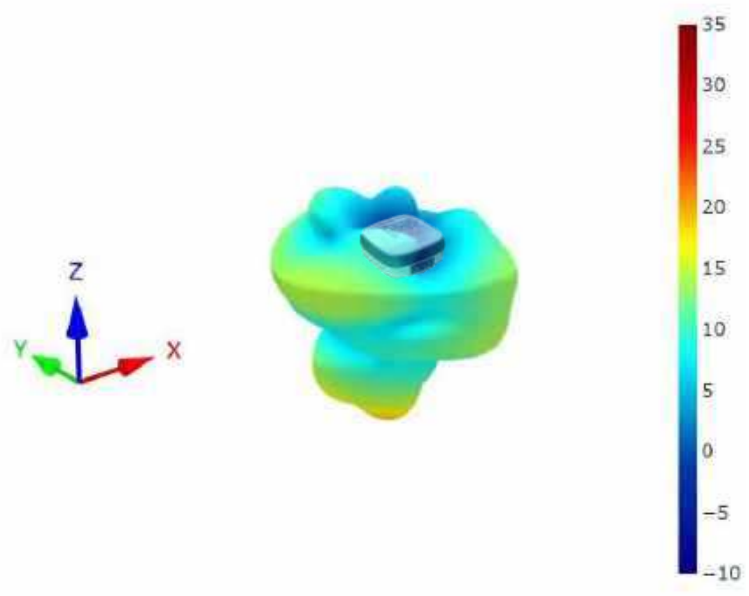

5.5 GNSS Patterns at 1575 MHz for AR [L1/E1/B1C]

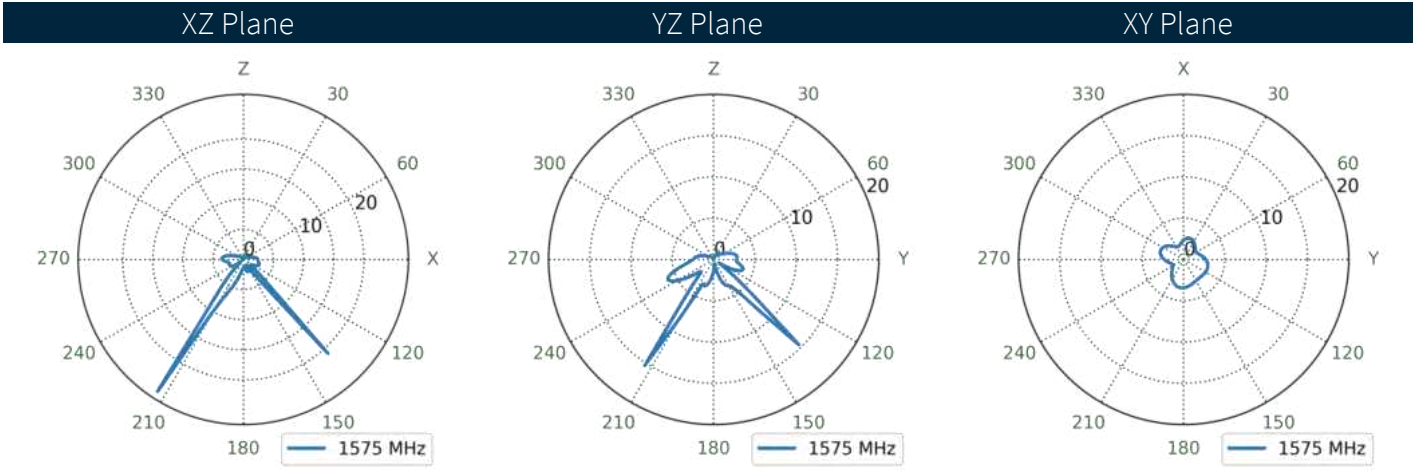
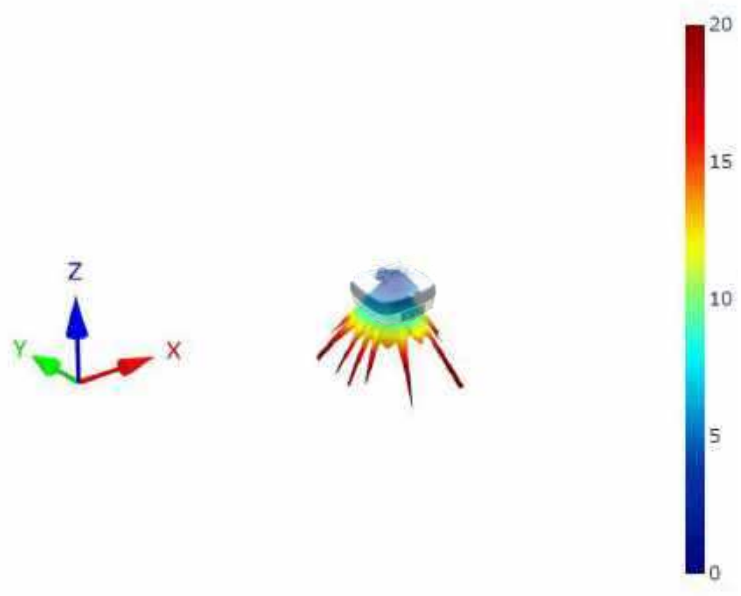

5.6 GNSS Patterns at 1228 MHz [L2]

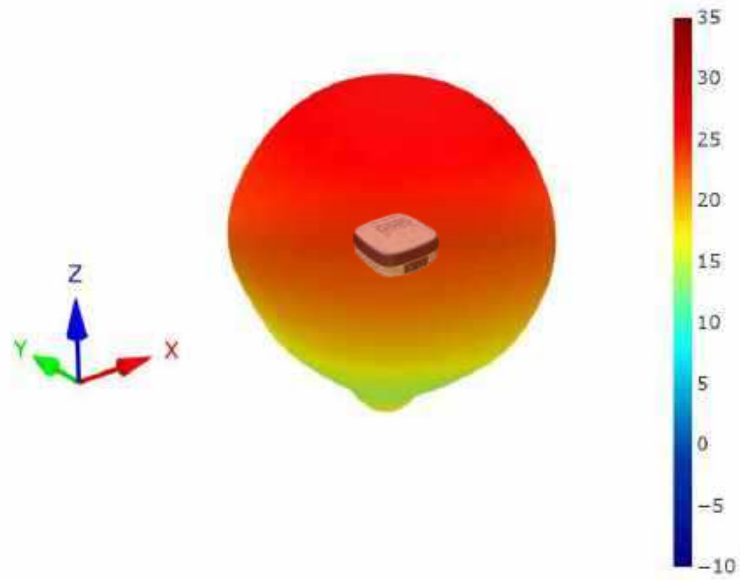

XZ Plane YZ Plane XY Plane

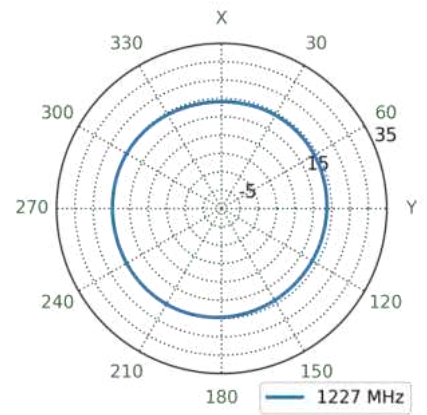
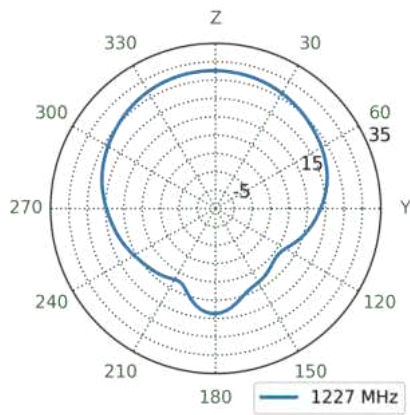
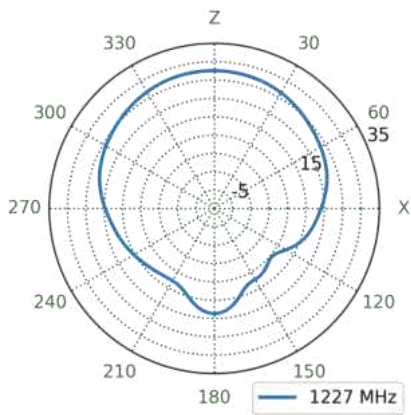

5.7 GNSS Patterns at 1228 MHz for GRHP [L2]

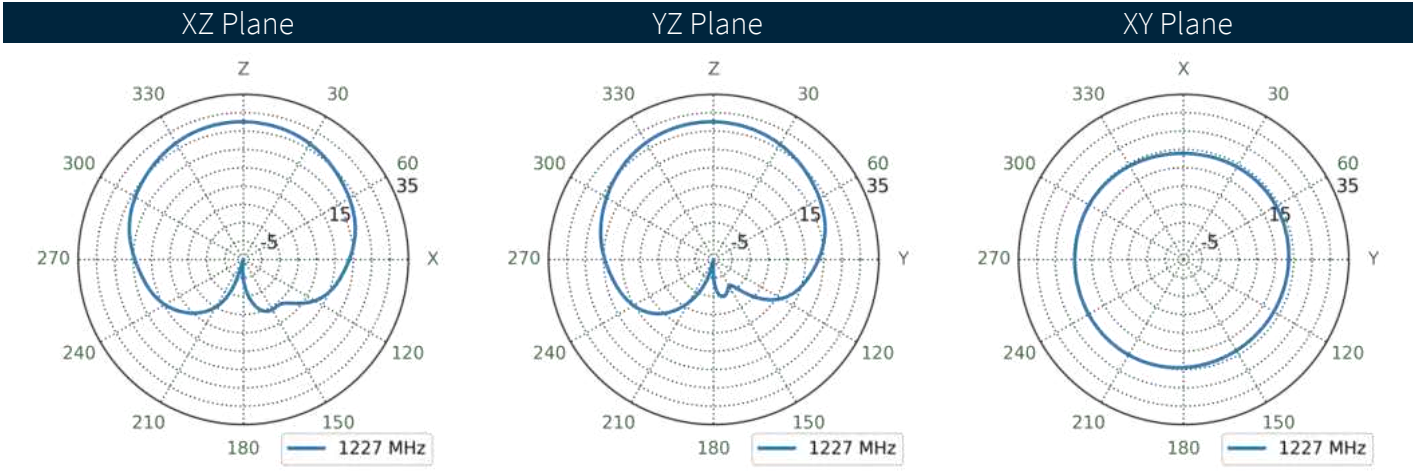
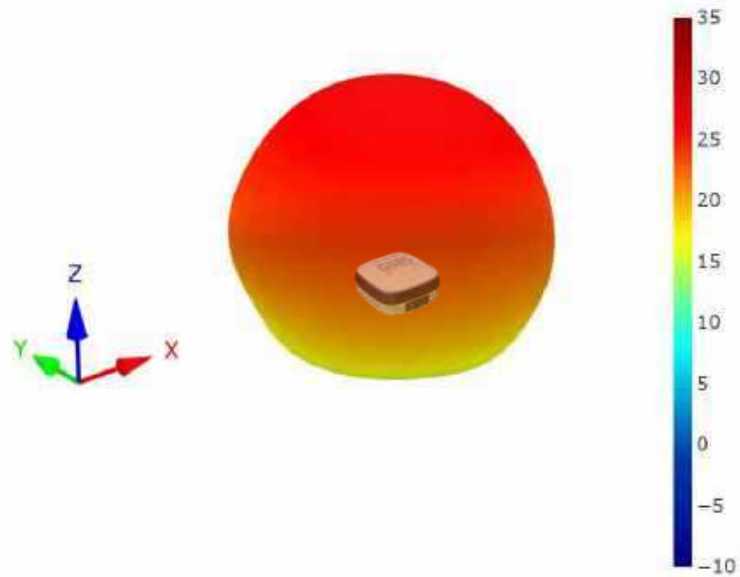

5.8 GNSS Patterns at 1228 MHz for GLHP [L2]

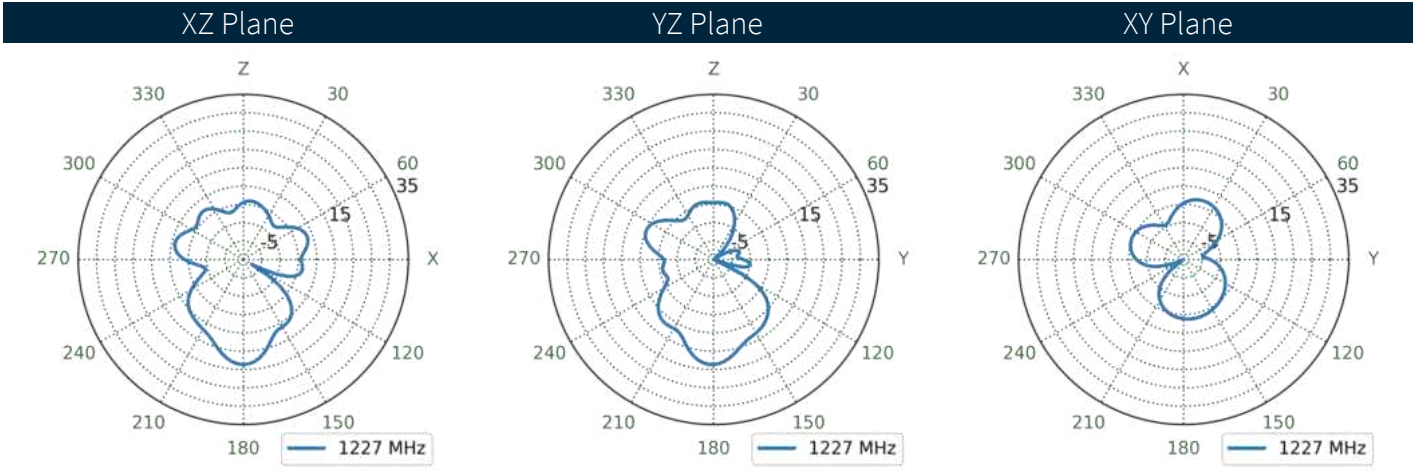
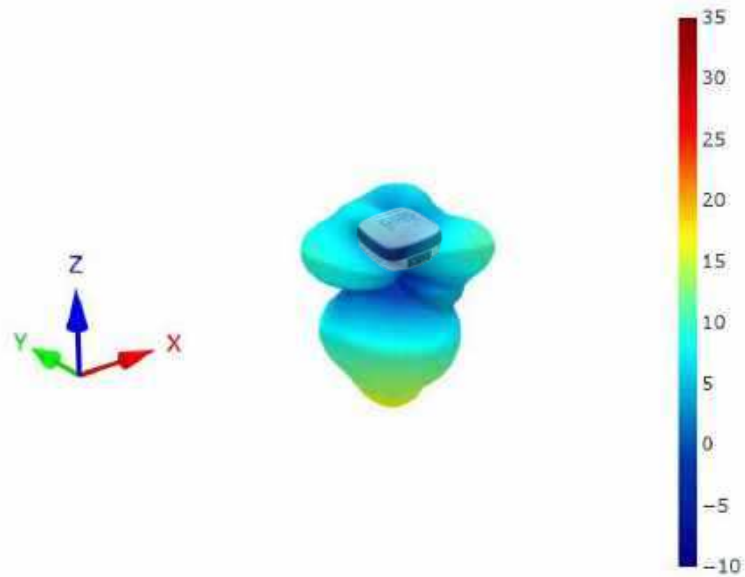

5.9 GNSS Patterns at 1228 MHz for AR [L2]

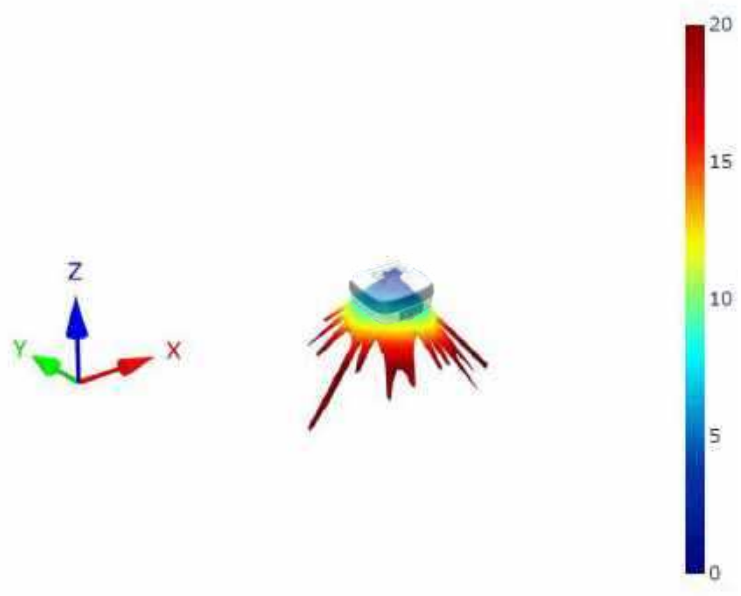

XZ Plane YZ Plane XY Plane

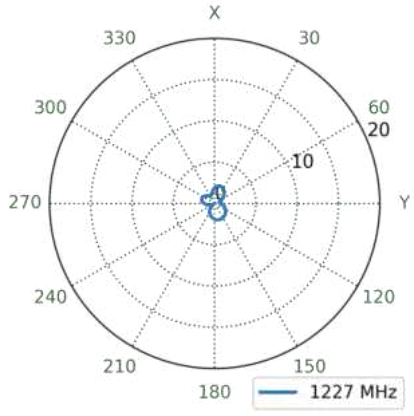
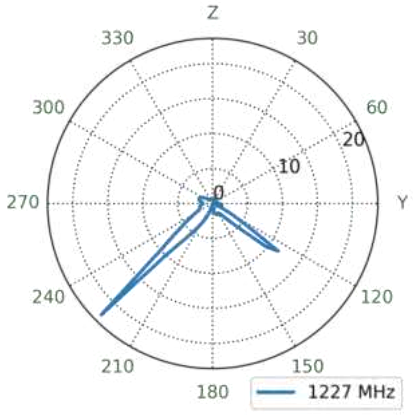
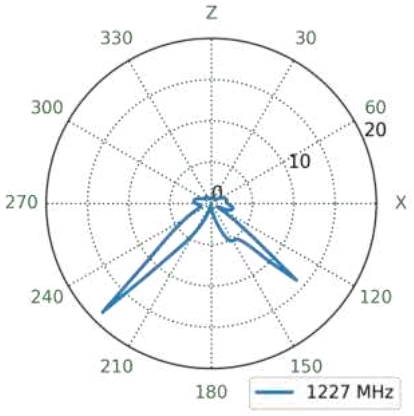

5.10 GNSS Patterns at 1176 MHz [L5/B2a/E5a]

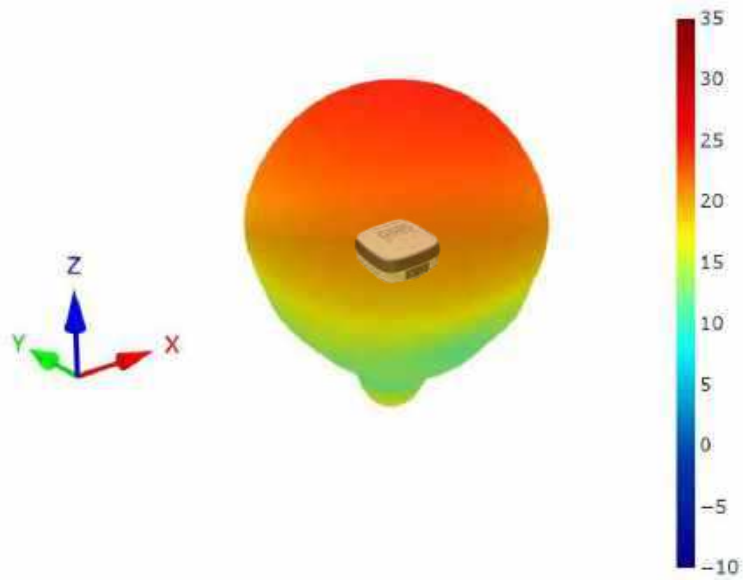

XZ Plane YZ Plane XY Plane

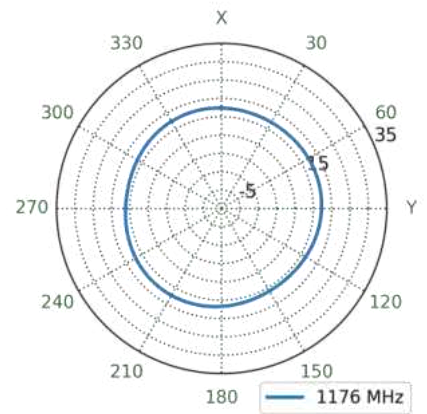
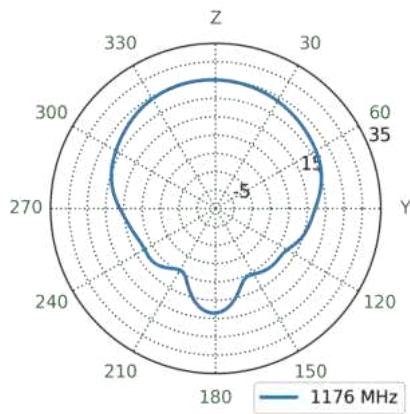
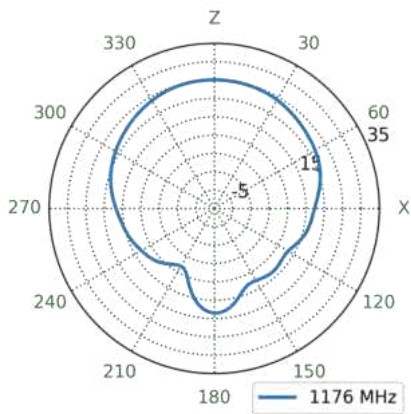

5.11 GNSS Patterns at 1176 MHz for GRHP [L5/B2a/E5a]

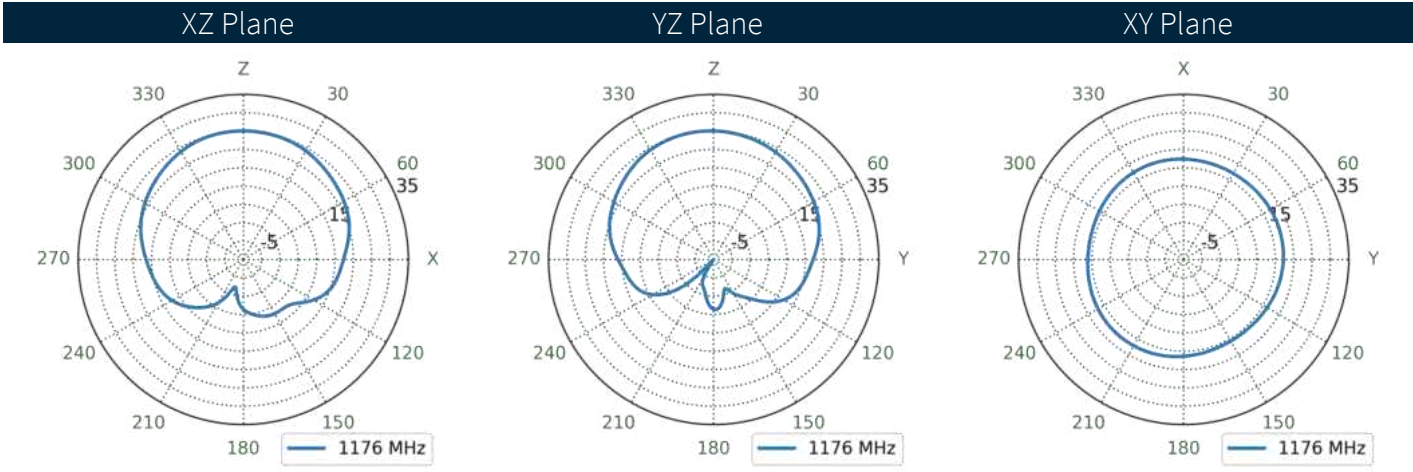
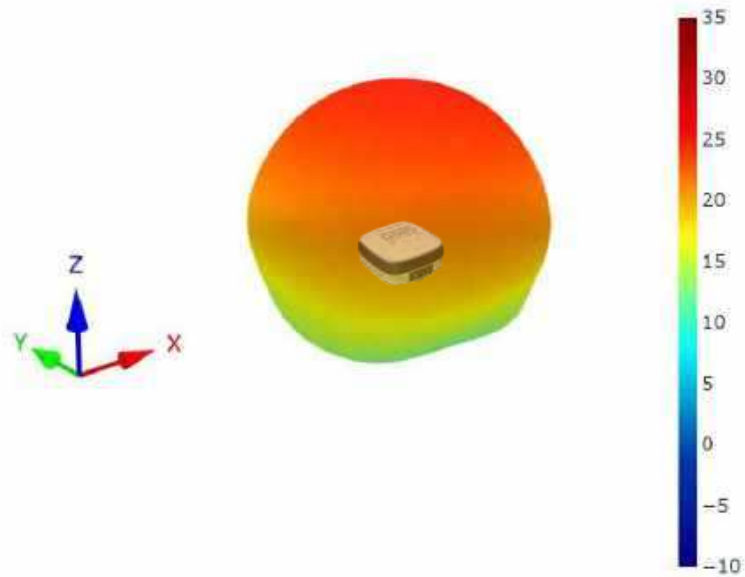

5.12 GNSS Patterns at 1176 MHz for GLHP [L5/B2a/E5a]

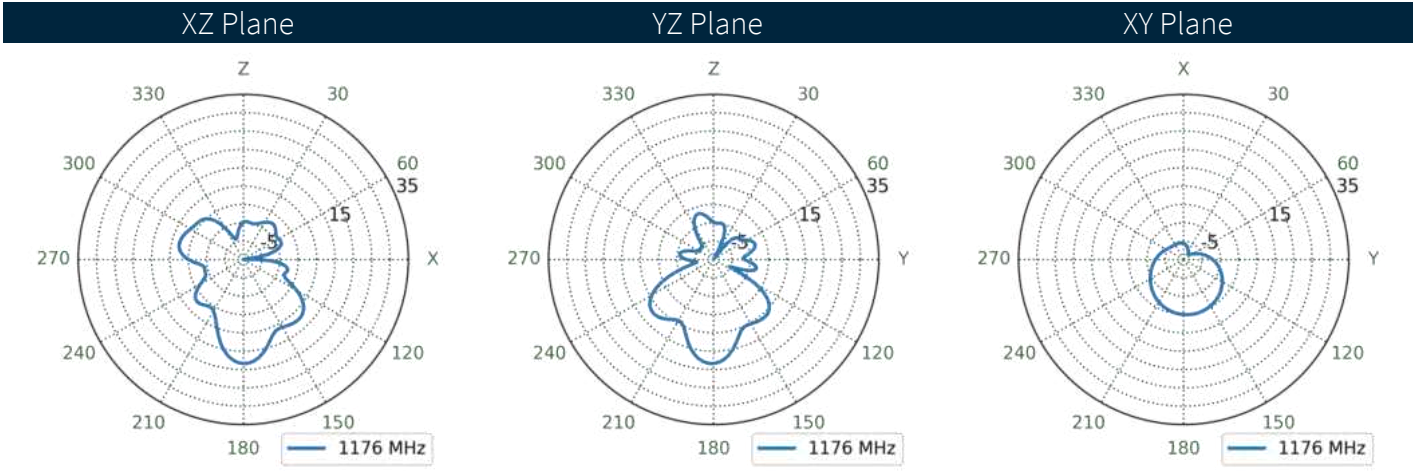
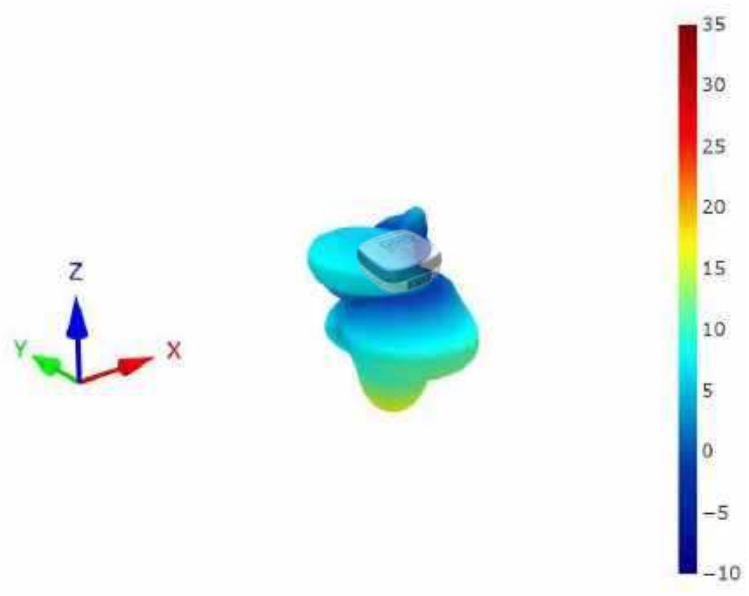

5.13 GNSS Patterns at 1176 MHz for AR [L5/B2a/E5a]

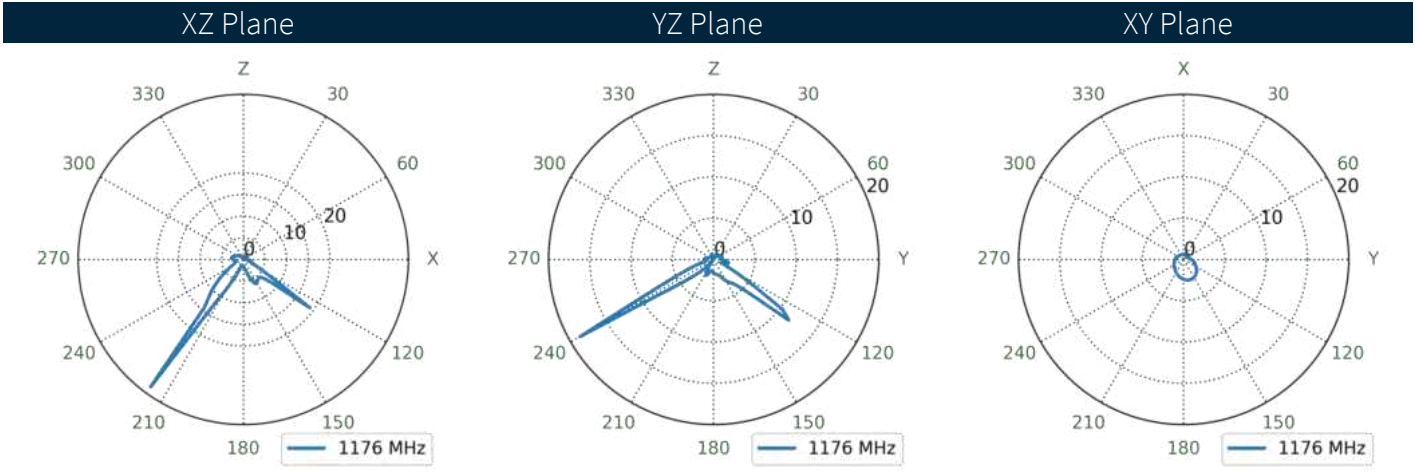
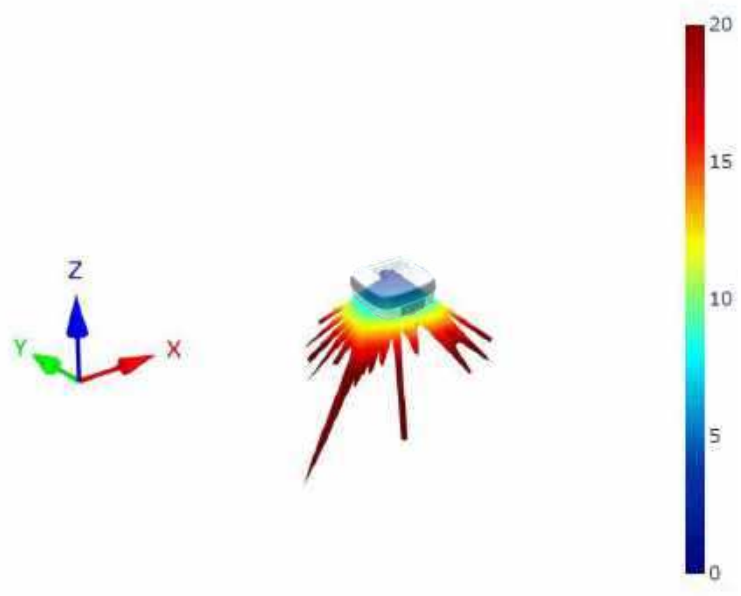

5.14 GNSS Patterns at 1201 MHz [B2b/E3b/G3]

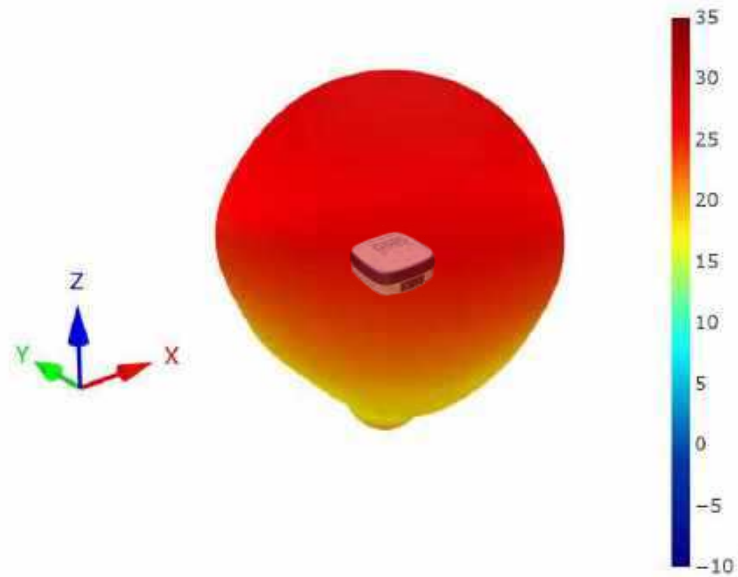

XZ Plane YZ Plane XY Plane

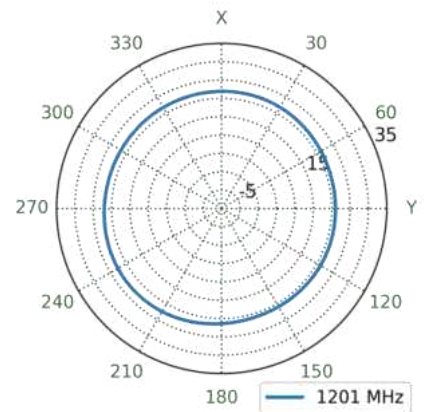
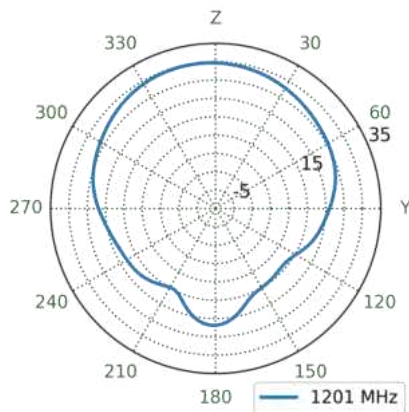
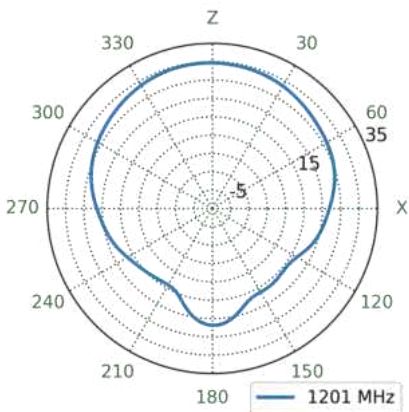

5.15 GNSS Patterns at 1201 MHz for GRHP [B2b/E3b/G3]

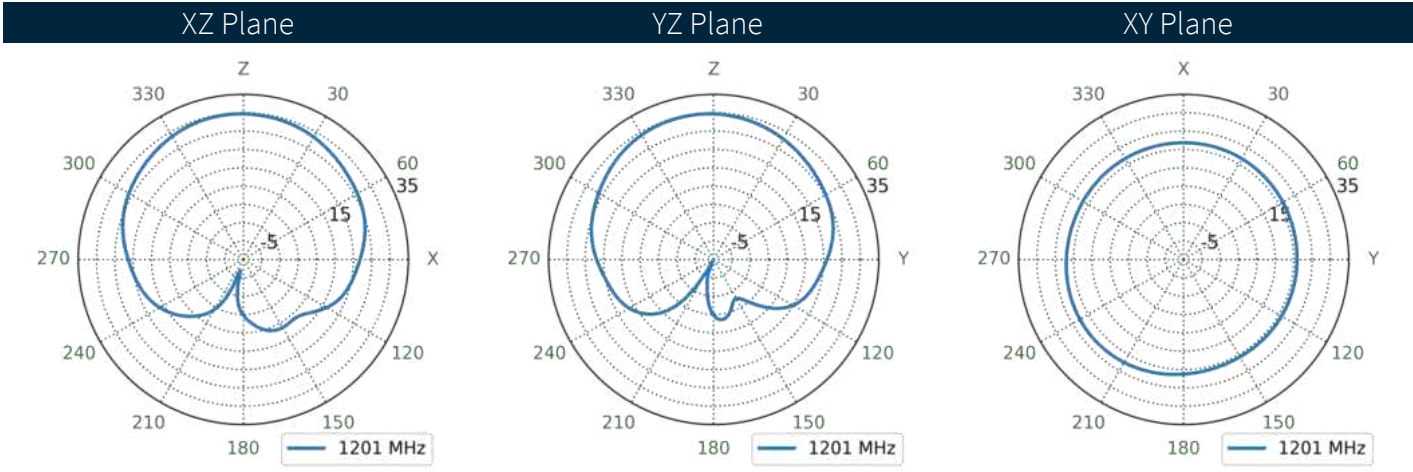
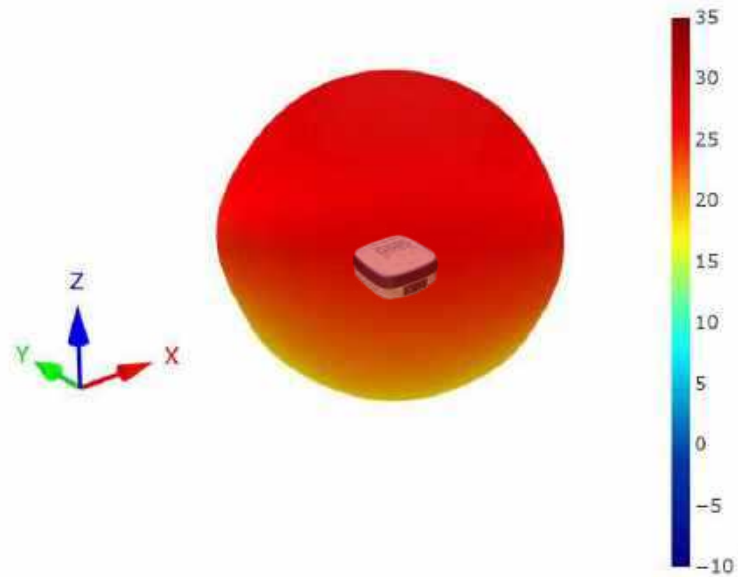

5.16 GNSS Patterns at 1201 MHz for GLHP [B2b/E3b/G3]

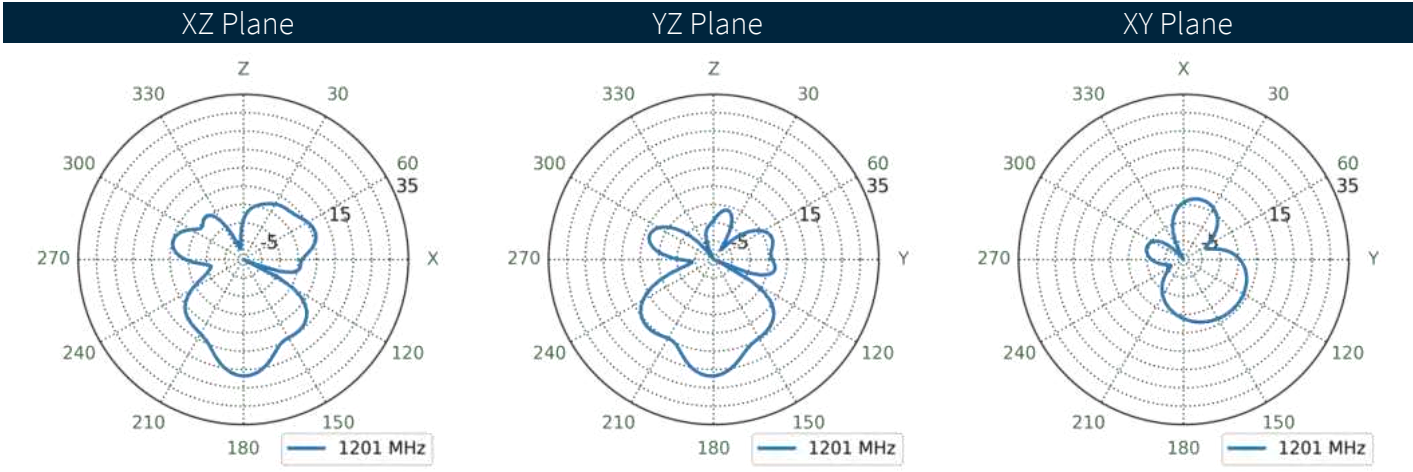
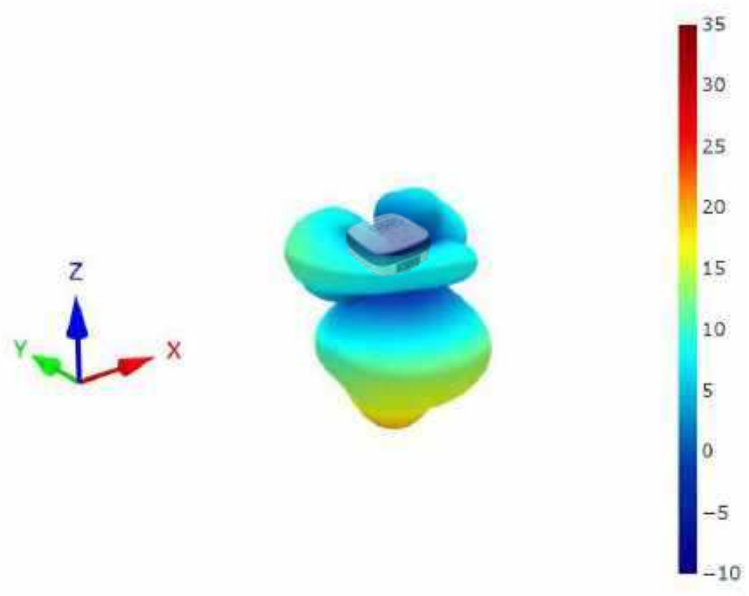

5.17 GNSS Patterns at 1201 MHz for AR [B2b/E3b/G3]

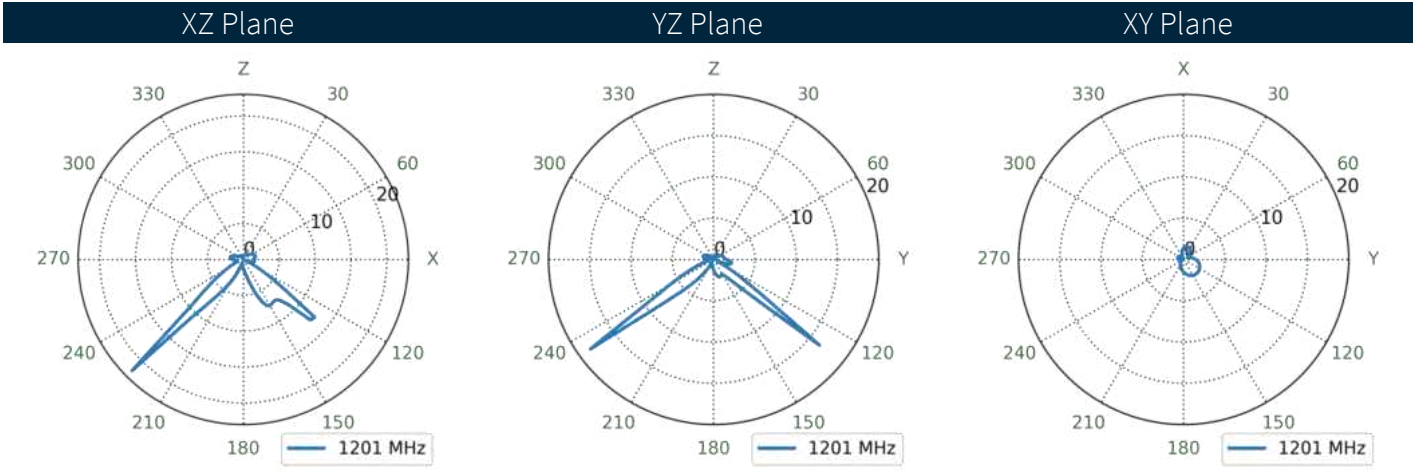
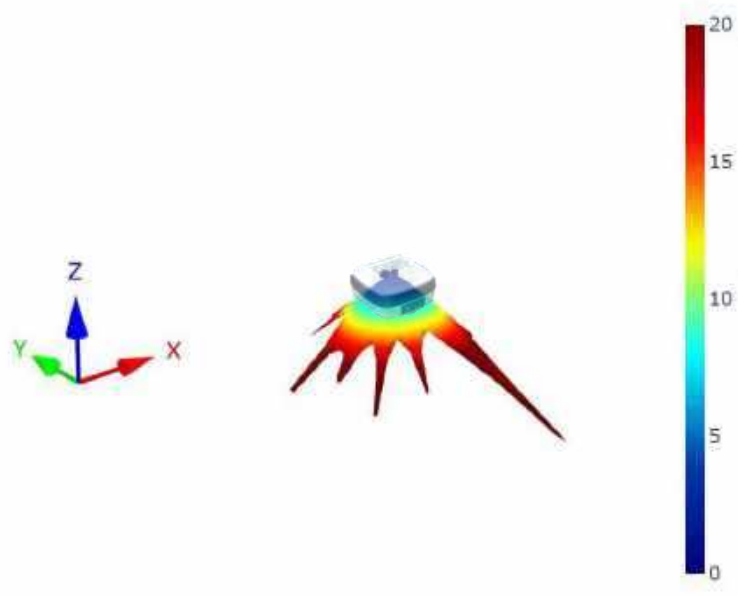

5.18 GNSS Patterns at 1603 MHz [G1]

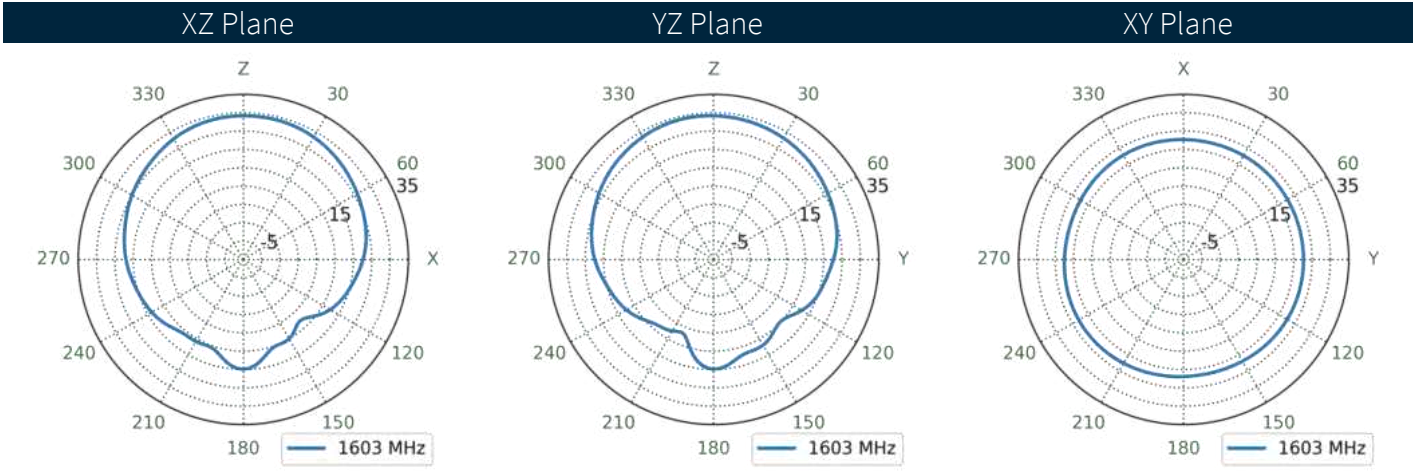
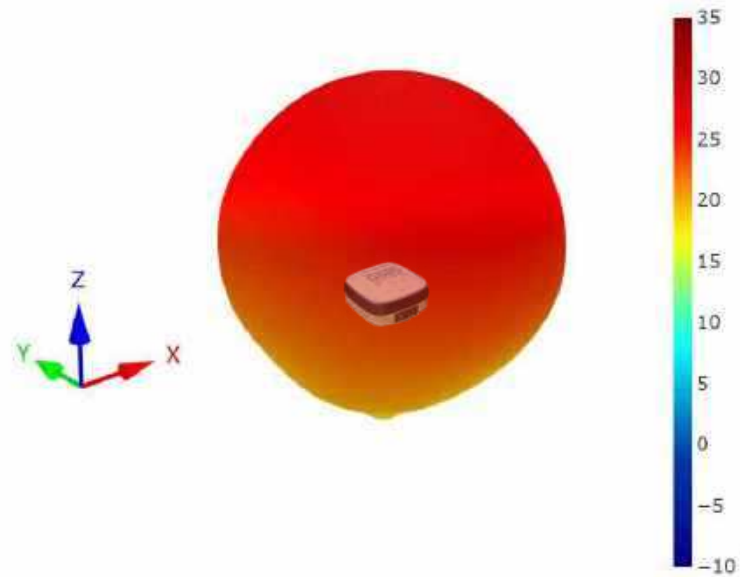

5.19 GNSS Patterns at 1603 MHz for GRHP [G1]

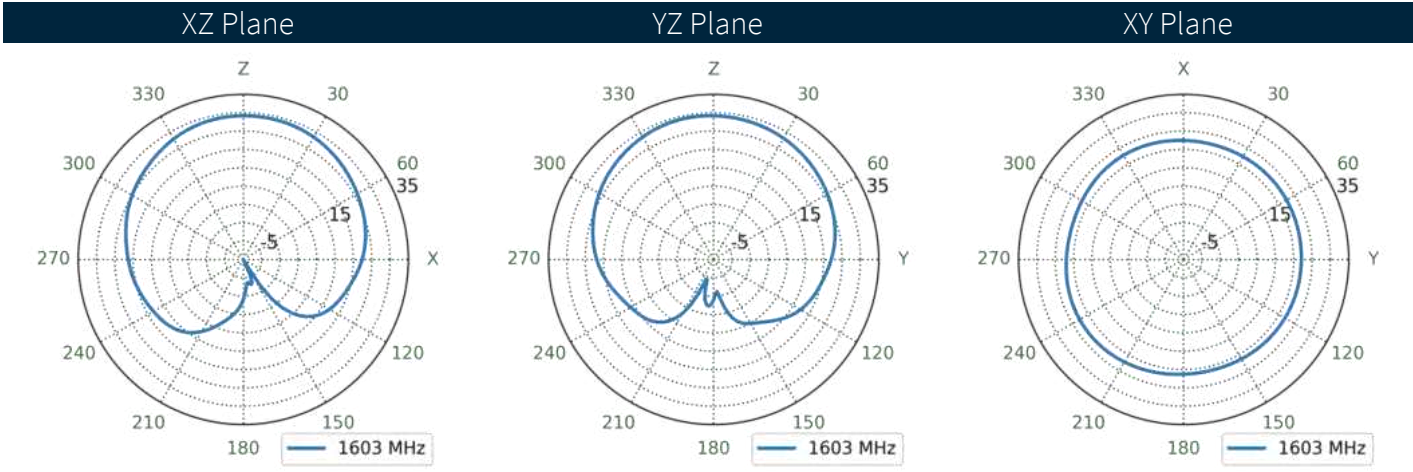
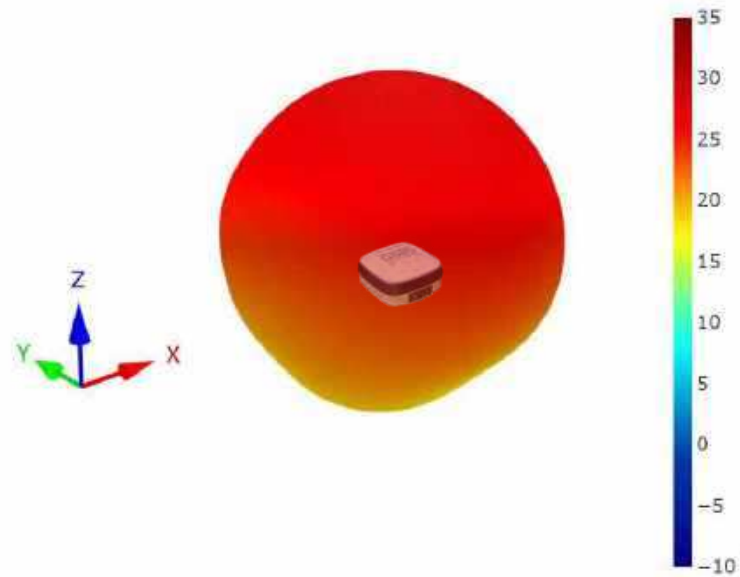

5.20 GNSS Patterns at 1603 MHz for GLHP [G1]

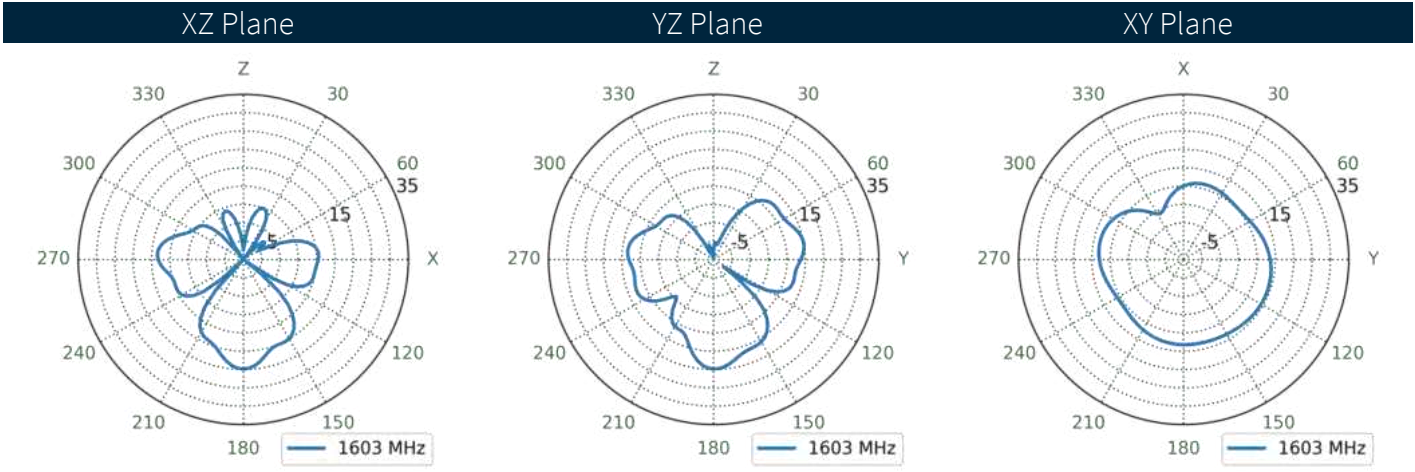
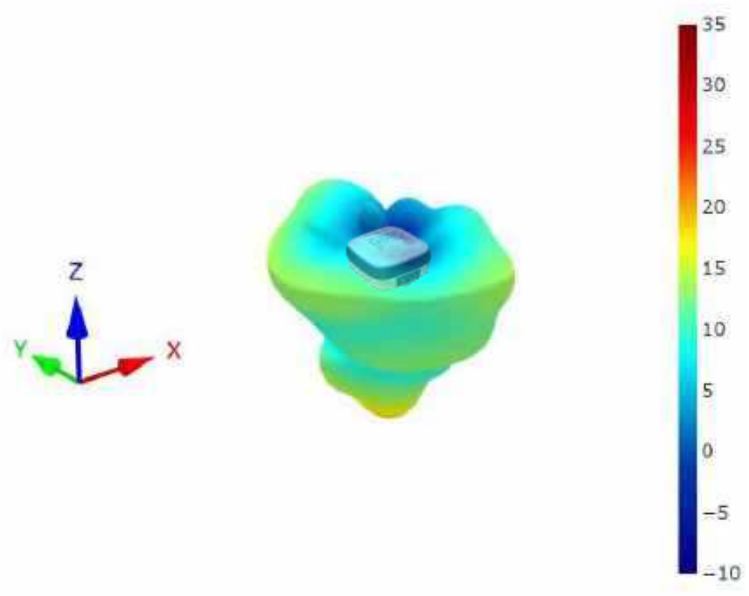

5.21 GNSS Patterns at 1603 MHz for AR [G1]

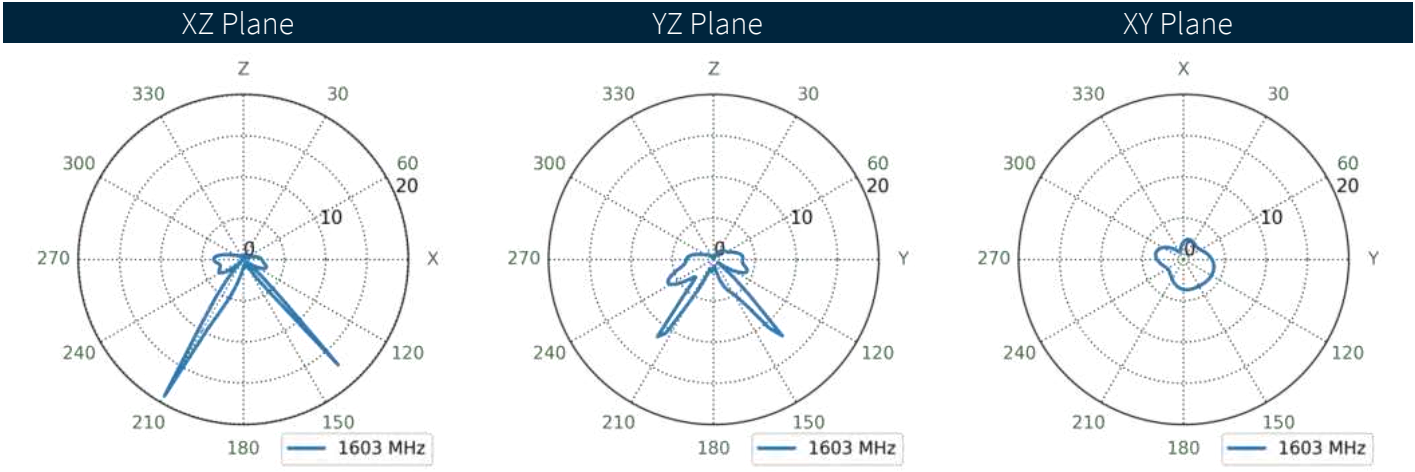
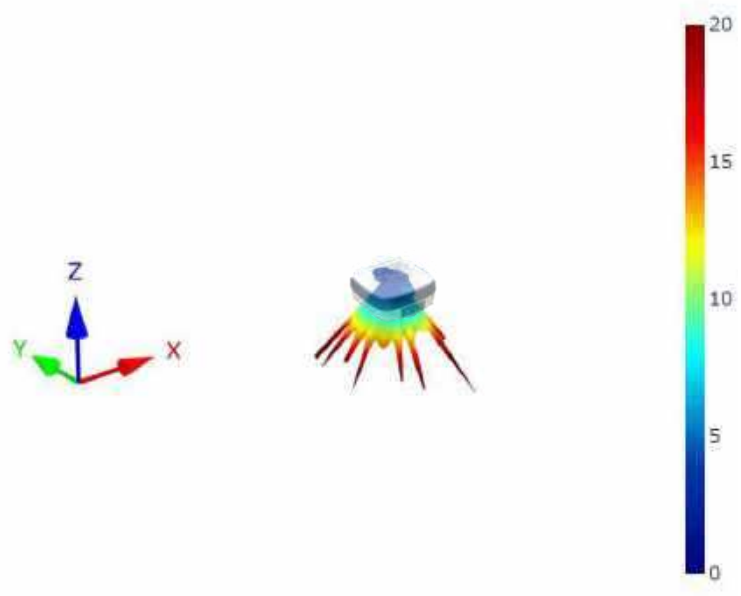

5.22 GNSS Patterns at 1248 MHz [G2]

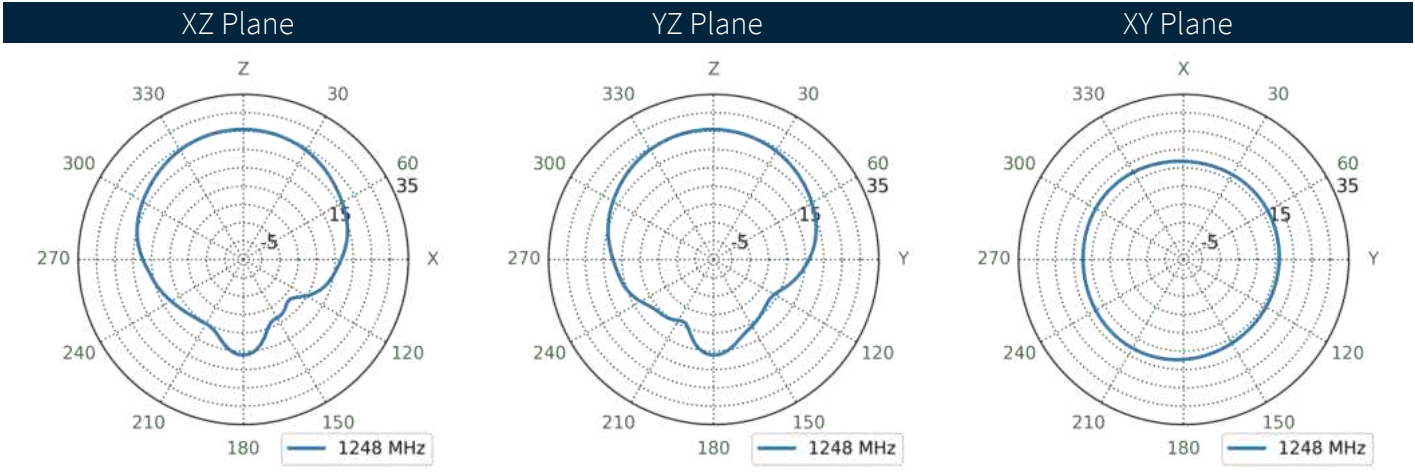
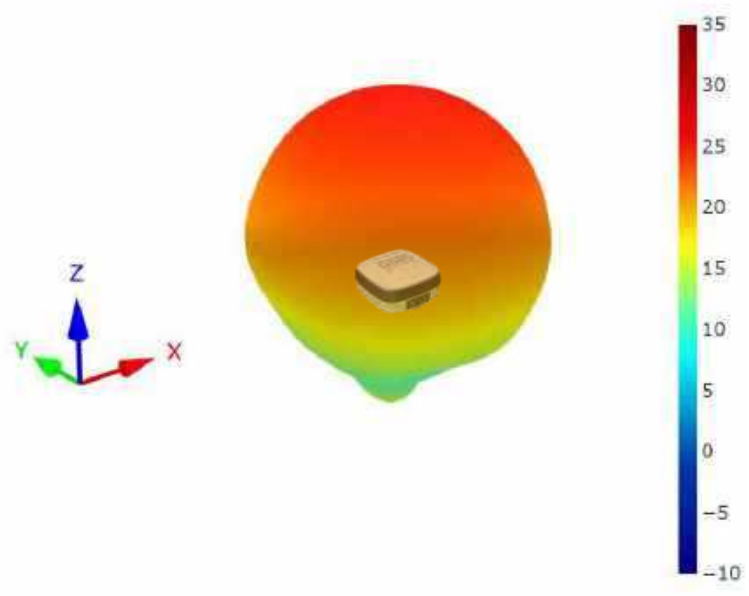

5.23 GNSS Patterns at 1248 MHz for GRHP [G2]

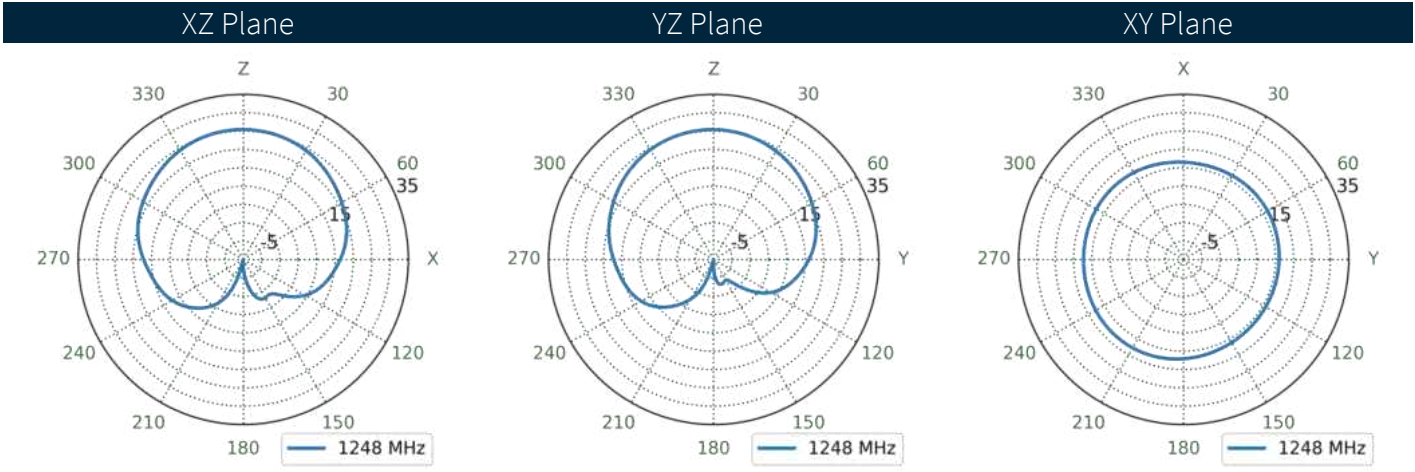
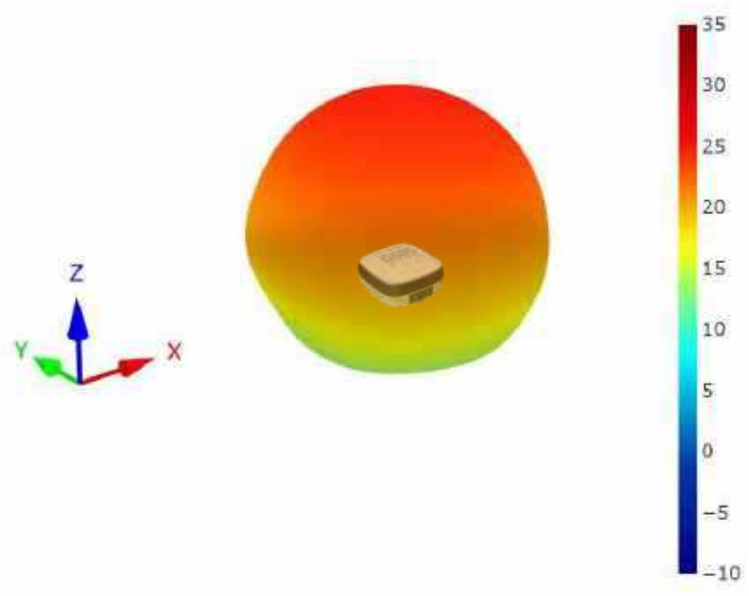

5.24 GNSS Patterns at 1248 MHz for GLHP [G2]

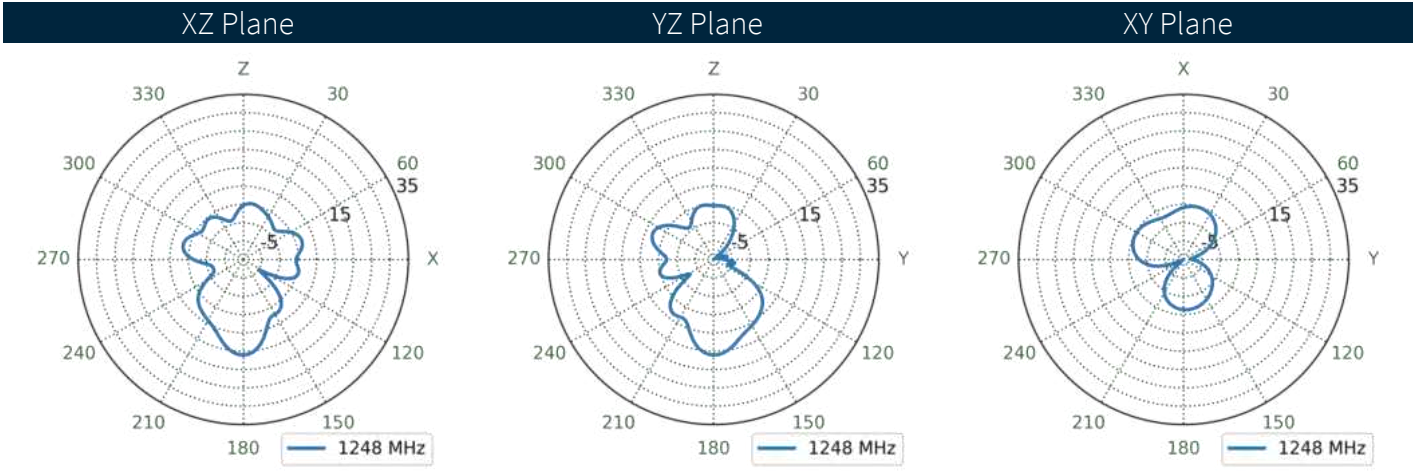
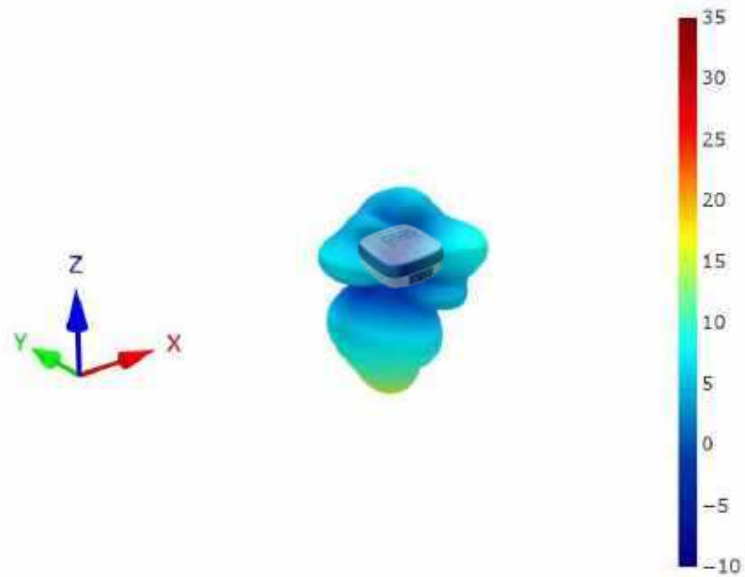

5.25 GNSS Patterns at 1248 MHz for AR [G2]



XZ Plane YZ Plane XY Plane

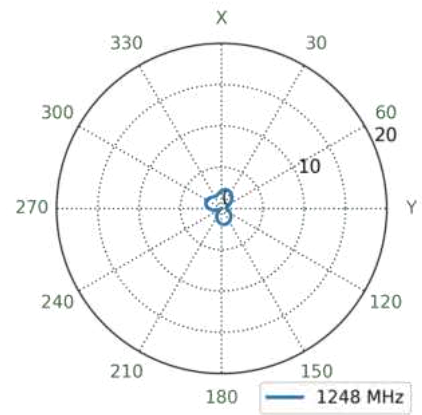
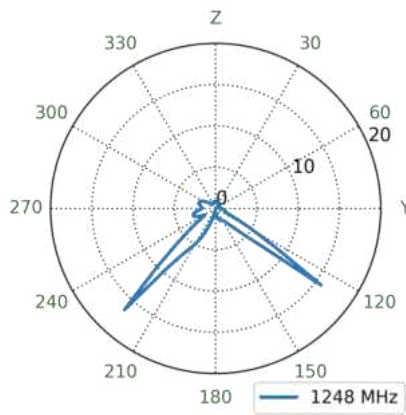
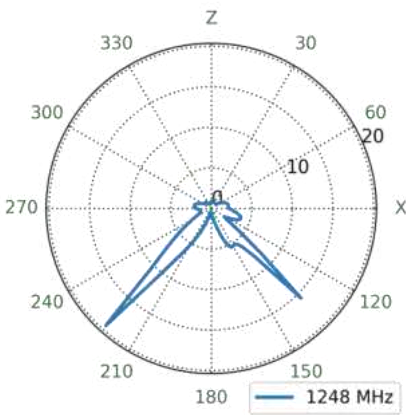

5.26 GNSS Patterns at 1562 MHz [B1]

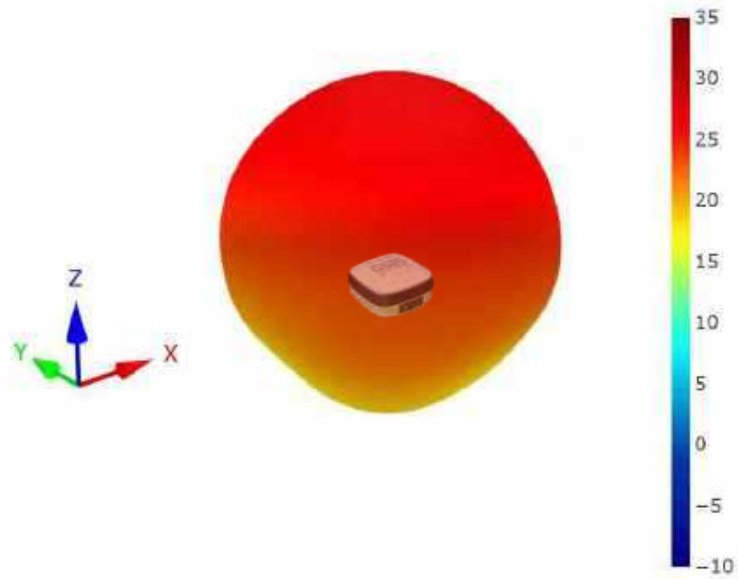

XZ Plane YZ Plane XY Plane

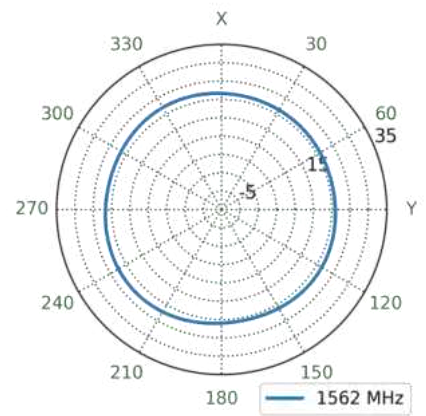
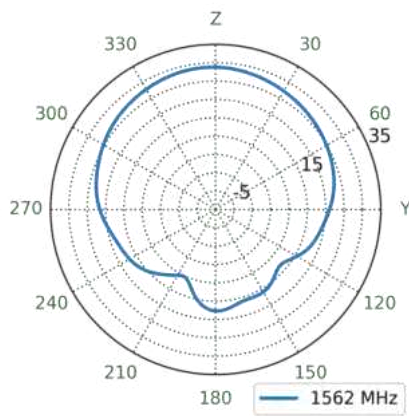
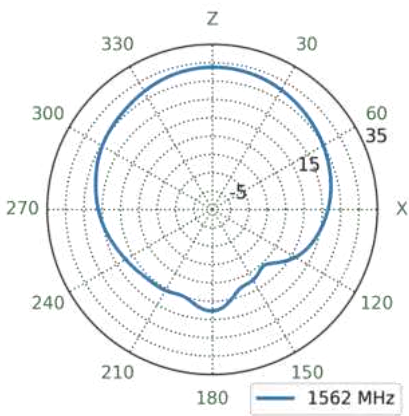

5.27 GNSS Patterns at 1562 MHz for GRHP [B1]

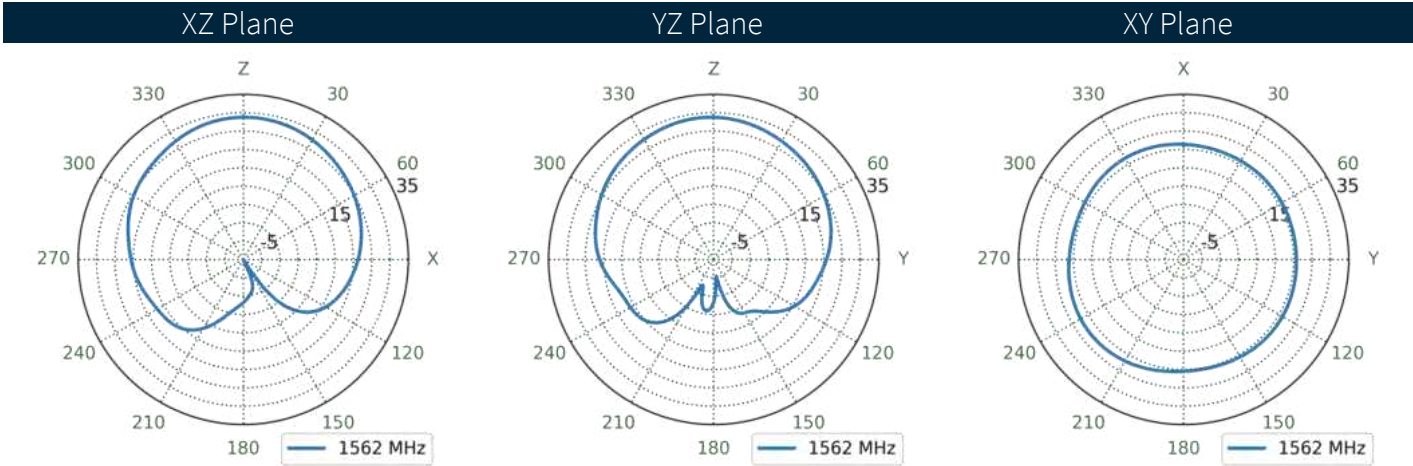
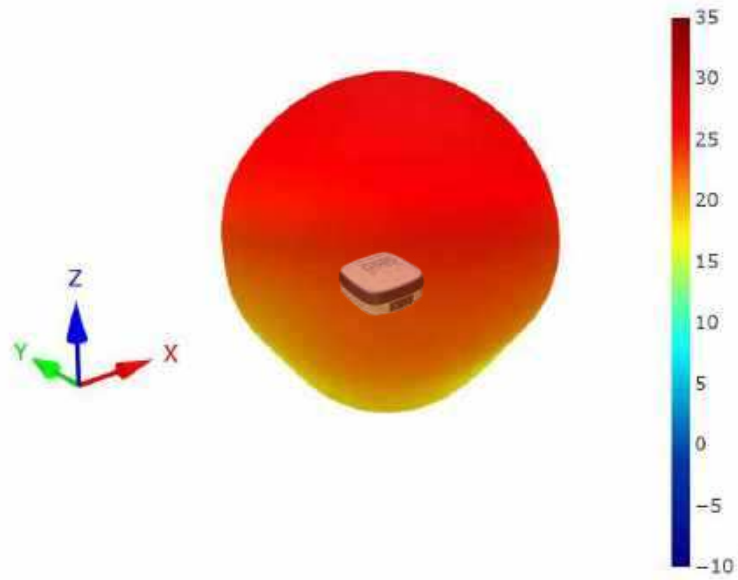

5.28 GNSS Patterns at 1562 MHz for GLHP [B1I]

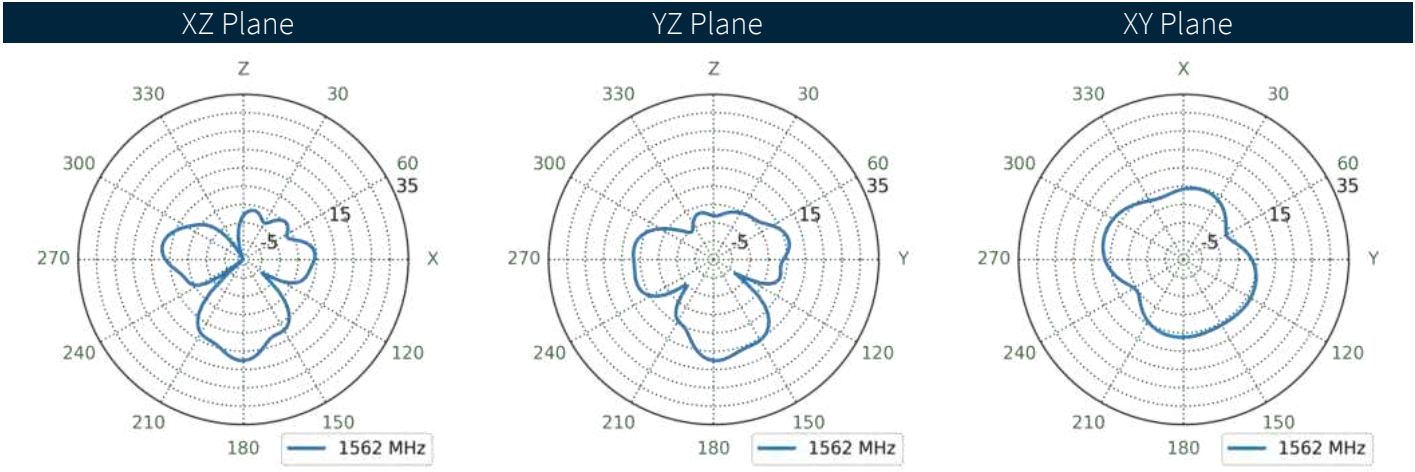
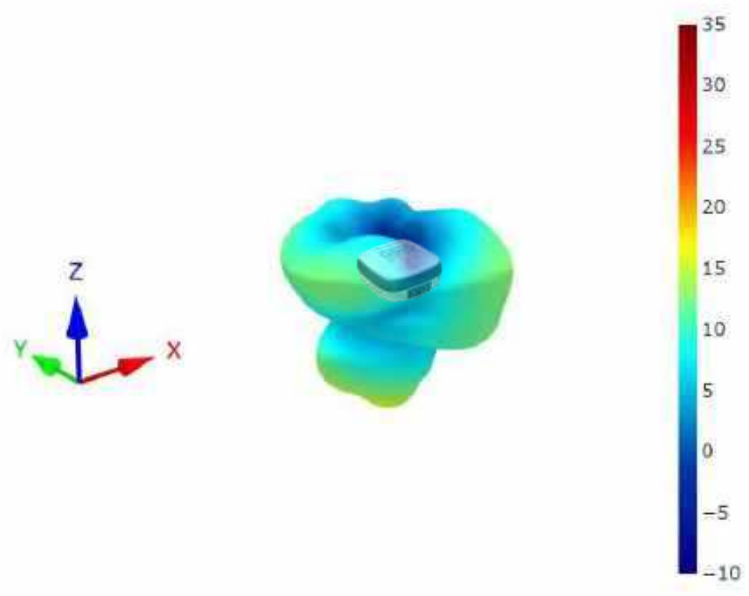

5.29 GNSS Patterns at 1562 MHz for AR [B1I]

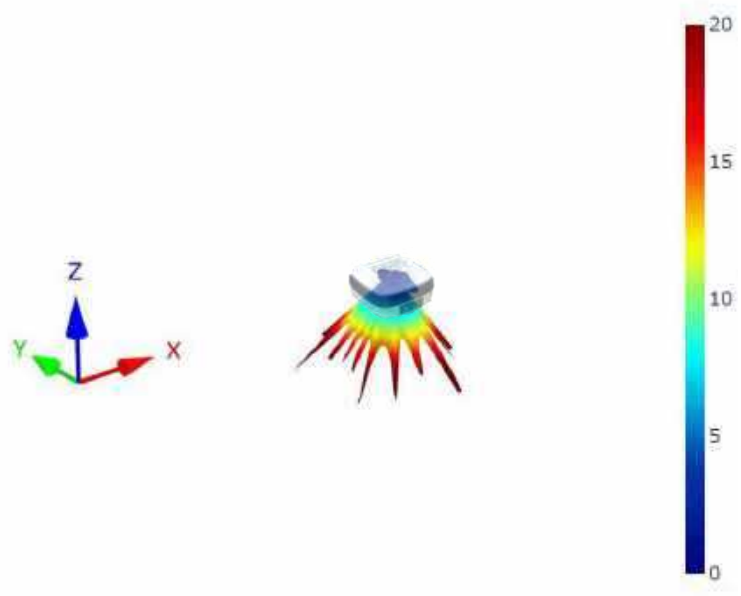

XZ Plane YZ Plane XY Plane

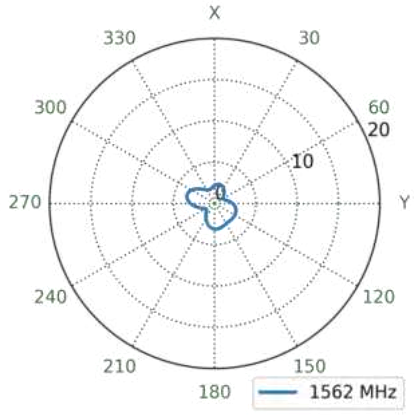
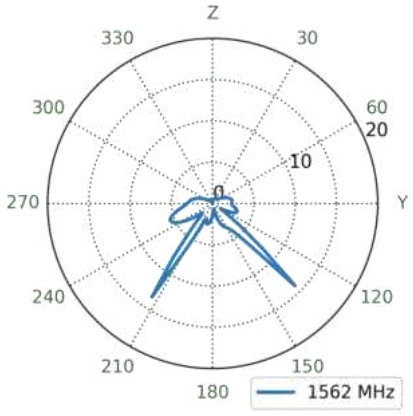
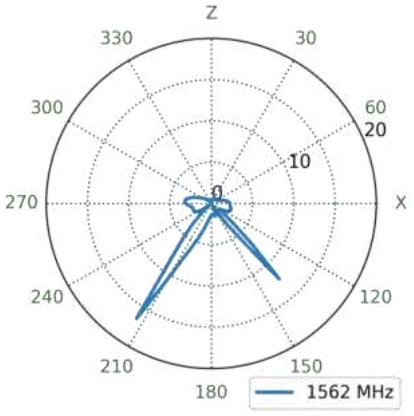

5.30 Wi-Fi1 Patterns at 2450 MHz

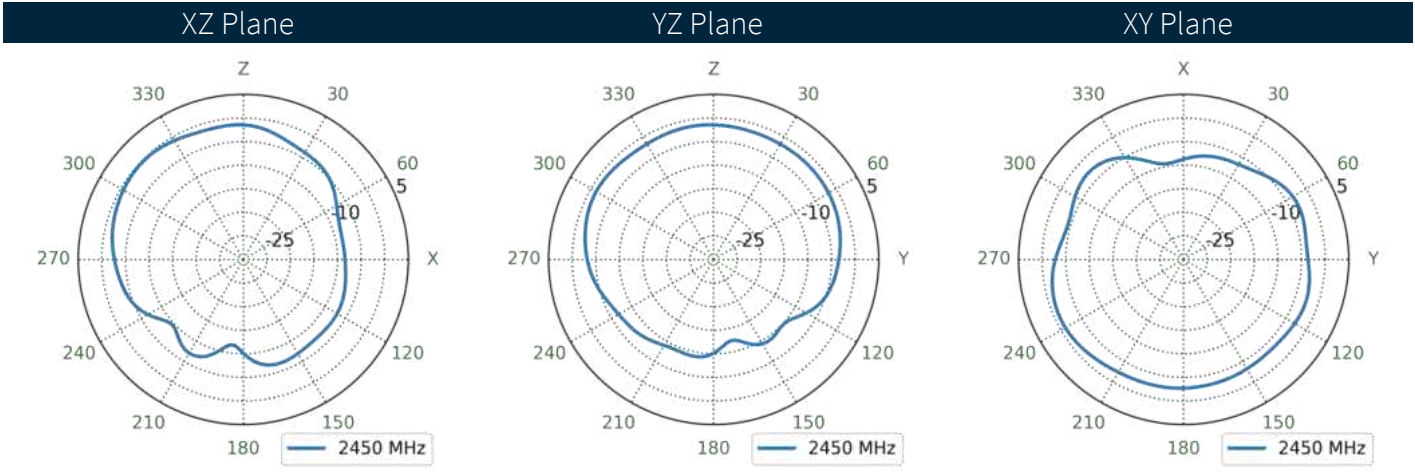
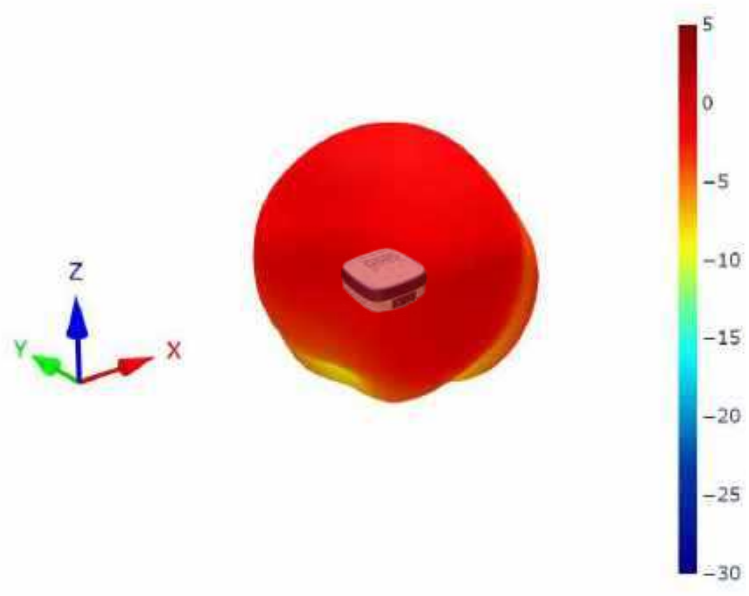

5.31 Wi-Fi2 Patterns at 2450 MHz

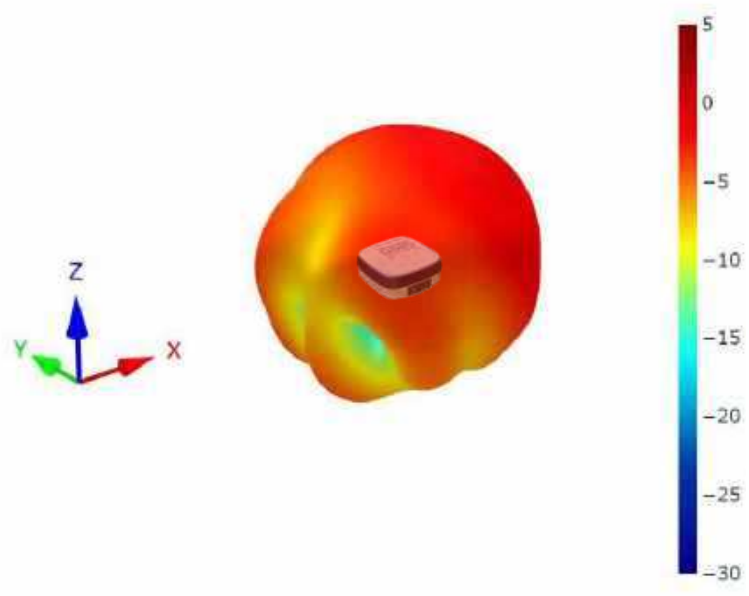

XZ Plane YZ Plane XY Plane

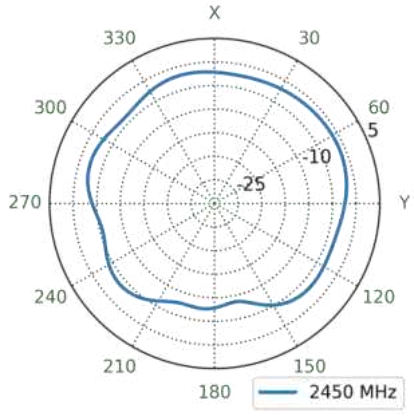
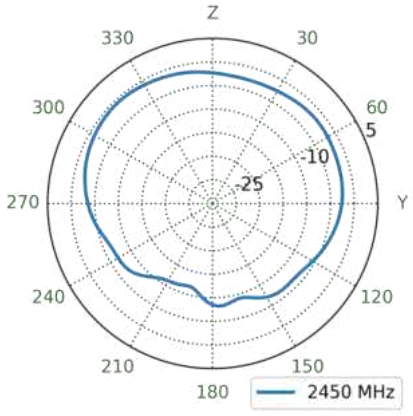
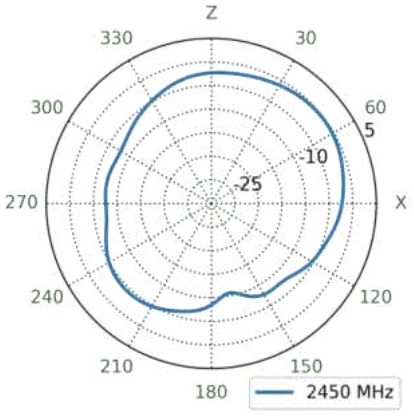

6. Mechanical Drawings

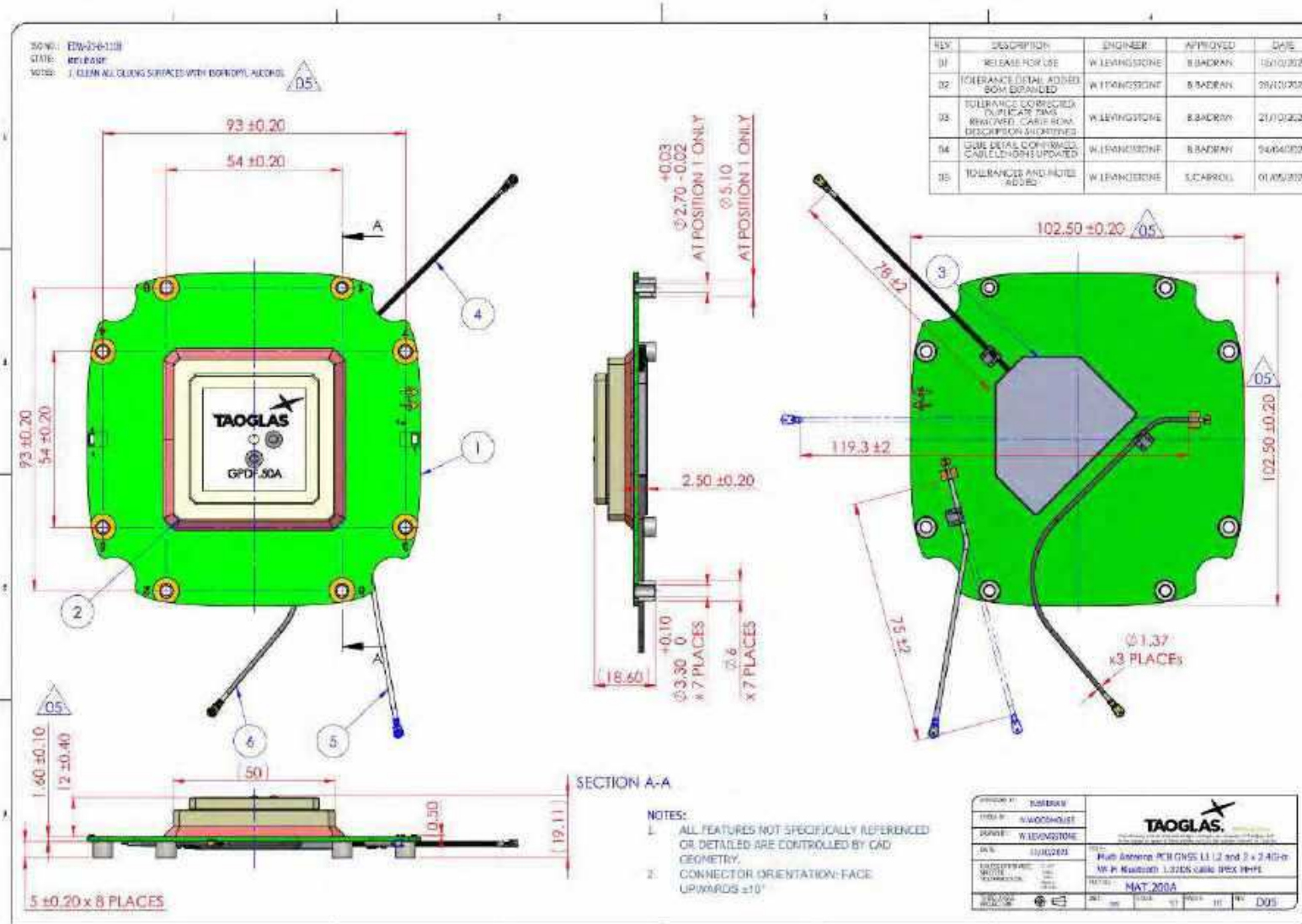

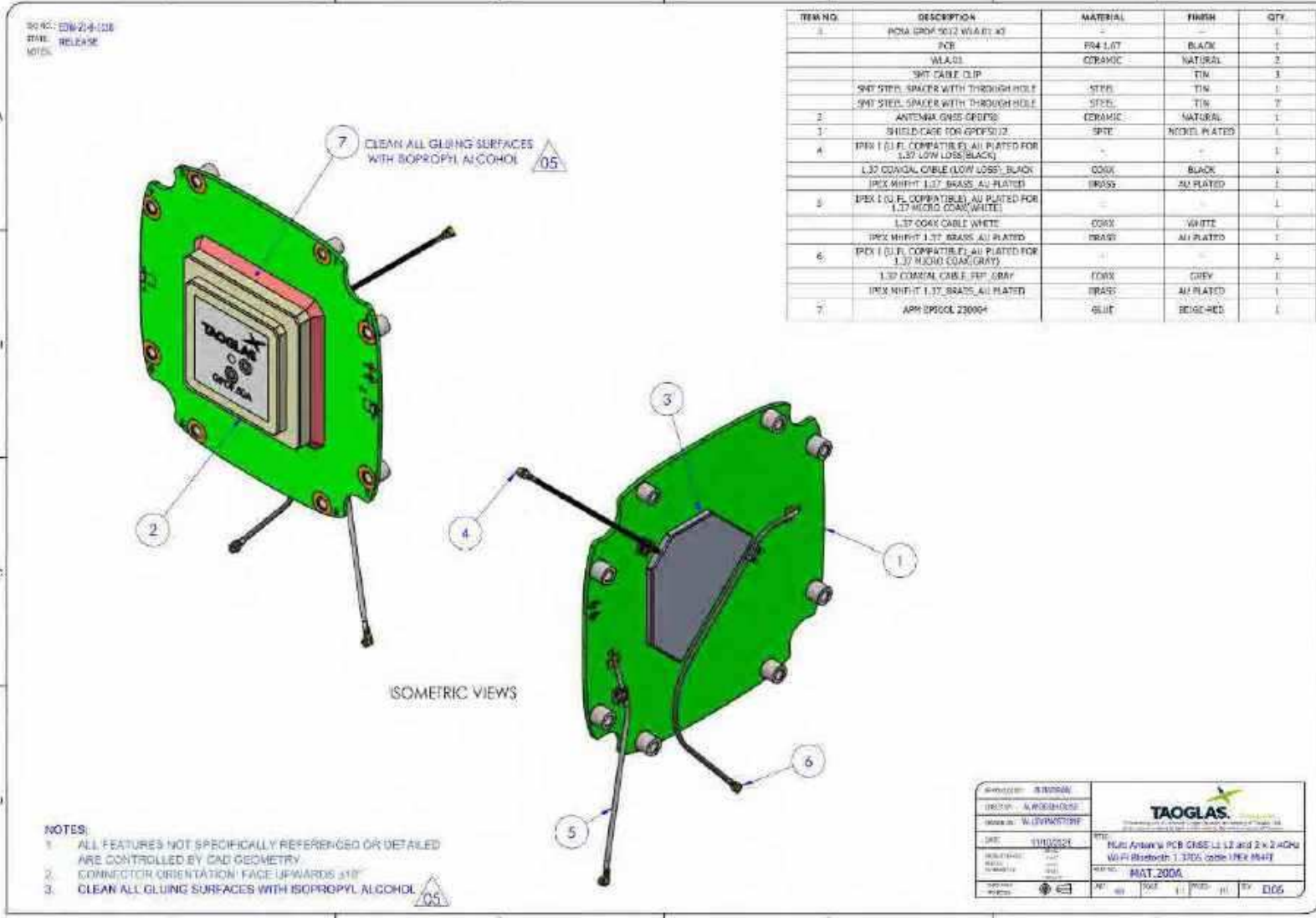

7. Packaging

1 pcs per antistatic bubble bag + PE Bag
 1 PCS per Desiccant 3g
 Weight : 130g



72 PCS per Carton
 4 PCS per Pocket
 2 PCS per Frame
 3 PCS per Bulkhead Board
 Carton Label
 Carton(mm) 370x370x300

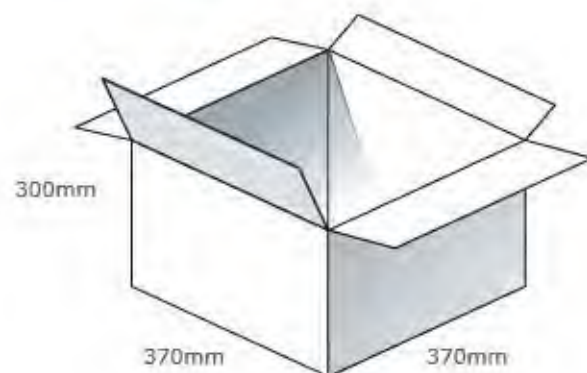
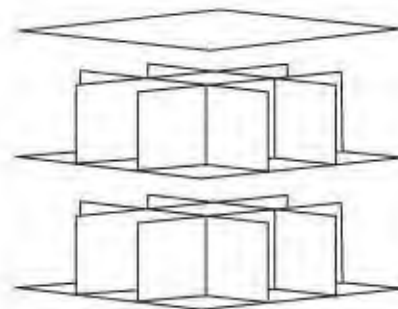

Changelog for the datasheet

SPE-23-8-082 – MAT.200A

Revision: B (Current Version)

Date:	2023-05-16
Notes:	Implemented changes after feedback from Leica
Author:	Lukas van Vuuren

Previous Revisions

Revision: A (Original First Release)

Date:	2023-04-03
Notes:	New Datasheet for Leica
Author:	Gary West



www.taoglas.com

