





EMC TEST REPORT FCC Title 47 CFR Part 15B, ISED ICES-003 Issue 7	
Report Reference No	G0M-2205-1481-EF0215B-V01
Testing Laboratory	Eurofins Product Service GmbH
Address	Storkower Str. 38c 15526 Reichenwalde Germany
Accreditation	    <p> A2LA - Registration number: 1983.01 (ISED) ISED wireless device testing laboratory: CN 3470A DAKKS - Registration number : D-PL-12092-01-04 (FCC) FCC Filed Test Laboratory, Reg.-No.: 96970 </p>
Applicant	Leica Geosystems AG
Address	Heinrich-Wild-Strasse 9435 Heerbrugg SWITZERLAND
Test Specification Standard(s)	FCC Title 47 CFR Part 15 Subpart B ISED ICES-Gen Issue 1 ; Amendment 1 (February 2021) ISED ICES-003 Issue 7 ANSI C63.4:2014+A1:2017
Non-Standard Test Method	None
Equipment under Test (EUT):	
Product Description	GNSS Reference Server with Bluetooth
Model(s)	GR50
Additional Model(s)	None
Brand Name(s)	Leica
Hardware Version(s)	B
Software Version(s)	4.61
FCC-ID	RFD-GR50BT
IC	3177A-GR50BT
Test Result	PASSED

Possible test case verdicts:		
required by standard but not tested	N/T	
not required by standard	N/R	
required by standard but not appl. to test object	N/A	
test object does meet the requirement	P(PASS)	
test object does not meet the requirement	F(FAIL)	
Testing:		
Date of receipt of test item	2022-07-29	
Report:		
Compiled by	Jens Marquardt	
Tested by (+ signature)	Marko Neuner	
Supervised by (+ signature) (Responsible for Test)	Stephan Liebich	
Approved by (+ signature) (Test Lab Engineer)	Andreas Pflug	
Date of Issue	2023-04-27	
Total number of pages	70	
General Remarks:		

The test results presented in this report relate only to the object tested.

The results contained in this report reflect the results for this particular model and serial number. It is the responsibility of the manufacturer to ensure that all production models meet the intent of the requirements detailed within this report.

This report shall not be reproduced, except in full, without the written approval of the Issuing testing laboratory.

Statement concerning the uncertainty of the measurement systems used for decisions on conformity (decision rule):

The Decision Rule is applied on the basis of CISPR16-4-2 and/or IEC61000-4-x (TR61000-1-6) and their national publications. These standards provide guidance on how to calculate and apply measurement uncertainty whilst providing maximum uncertainties allowance. In all cases due consideration will be given to ILAC-G8:09/2019.

Compliance or non-compliance with a disturbance limit is determined in the following manner.

- If U_{lab} is less than or equal to U_{cispr} , then: compliance is deemed to occur if no measured disturbance level exceeds the disturbance limit; non-compliance is deemed to occur if any measured disturbance level exceeds the disturbance limit.
- If U_{lab} is greater than U_{cispr} , then: compliance is deemed to occur if no measured disturbance level, increased by $(U_{lab} - U_{cispr})$, exceeds the disturbance limit; non-compliance is deemed to occur if any measured disturbance level, increased by $(U_{lab} - U_{cispr})$, exceeds the disturbance limit.

Where appropriate for the test, for example for EMC pulsed immunity tests, the laboratory has demonstrated, by calibrating its equipment and facilities, that it complies with the above requirements and therefore no allowance of uncertainties has been given to the tolerances.

Additional Comments:

-

ADDITIONAL NOT TESTED MODEL(S)

Additional variants have been declared by the manufacturer. The listed models were not tested, evaluated or assessed in no way.		
Additional Model 1	Product Type Description	GNSS Surveying Receiver with Bluetooth
	Model Name	GS25
	Brand Name (optional)	Leica
	Hardware Version	B
	Software Version	4.61

ABBREVIATIONS AND ACRONYMS

Acronyms	
Acronym	Description
EUT	Equipment Under Test
FCC	Federal Communications Commission
ISED	Innovation, Science and Economic Development Canada
T _{NOM}	Nominal operating temperature
V _{NOM}	Nominal supply voltage

VERSION HISTORY

Version History			
Version	Issue Date	Remarks	Revised By
01	2023-04-27	Initial Release	-

REPORT INDEX

1	Equipment (Test Item) Under Test.....	8
1.1	Equipment Ports.....	9
1.2	Equipment Photos - Internal.....	11
1.3	Equipment Photos - External.....	17
1.4	Support Equipment.....	28
1.5	Operational Modes.....	29
1.6	EUT Configuration.....	30
1.7	Sample emission level calculation.....	32
2	Result Summary.....	33
2.1	Test Conditions and Results - Radiated emissions acc. to ANSI C63.4.....	34
2.2	Test Conditions and Results - Conducted emissions acc. to ANSI C63.4.....	58
3	Measurement Uncertainty	70

1 Equipment (Test Item) Under Test

Description	GNSS Reference Server with Bluetooth		
Intended Use	<ul style="list-style-type: none"> • Carrying out measurement tasks using various GNSS measuring techniques. • Recording GNSS and point related data. • Data communication with external appliances. • Measuring raw data and computing coordinates using carrier phase and code signal from GNSS satellites 		
Model	GR50		
Additional Model(s)	None		
Brand Name(s)	Leica		
Hardware Version(s)	B		
Software Version(s)	4.61		
Number of tested samples	1		
Sample Identification	EUT #	Sample-ID	Serial Number
	EUT 1 BT	40910	2092006
EUT Dimensions [cm]	22 x 20 x 9.4		
FCC-ID	RFD-GR50BT		
IC	3177A-GR50BT		
Class	Class B		
Equipment type	Table top		
Highest internal frequency [MHz]	2490		
Protective Earth	None		
Radio Module	Type	Radio module Bluetooth	
	Model	PAN1310	
	Manufacturer	Panasonic Industrial Devices Europe GmbH	
	Hardware Version	02	
	Software Version	03	
	FCC-ID	T7VEBMU or Q2331307	
	IC	216QEBMU	
Supply Voltage	V _{NOM}	24 V DC via dedicated AC/DC-Adaptor; 14.4 V DC via rechargeable lithium battery; 48 V DC via Power over LAN (PoE)	
AC/DC-Adaptor	Model	GEV242	
	Vendor	XP Power	
	Input	110-240 V / 47-63 Hz	
	Output	24 V DC	
Manufacturer	Leica Geosystems AG Heinrich-Wild-Strasse 9435 Heerbrugg SWITZERLAND		
Factory	Leica Geosystems AG Heinrich-Wild-Strasse 9435 Heerbrugg SWITZERLAND		

1.1 Equipment Ports

Name	Type	Attributes	Comment
PWR	DC	Count: 1 Cable length [m]: <2.8 Direction: In Service only: No Shielded: No	Ext. AC/DC-Adapter or battery (o)
AC Mains	AC	Count: 1 Cable length [m]: >3 Direction: In Service only: No Shielded: No	Port of dedicated AC/DC-Adaptor
GNSS Antenna Port (P1, P2)	IO	Count: 1 Cable length [m]: >1.2 Direction: In Service only: No Shielded: Yes	TNC connector Coax cable TNC Connector for GNSS Antenna (g)
Bluetooth Antenna Port	IO	Count: 1 Cable length [m]: 0 Direction: IO Service only: No Shielded: Yes	RP-SMA Connector for Antenna (i)
Serial Interface und 12V Out	IO	Count: 2 Cable length [m]: <3m Direction: IO Service only: No Shielded: Yes	Port 1 data communication Port 2 Passive connection LED with resistor Port for external sensors (k,l); port not exercised, only passively terminated
Oscillator Port	IO	Count: 1 Cable length [m]: <3m Direction: In Service only: No Shielded: Yes	Passive termination Input port for external oscillator; port not exercised, only passively terminated
PPS Out	IO	Count: 1 Cable length [m]: <3m Direction: IO Service only: No Shielded: Yes	Puls per second output (j); port not exercised, only passively terminated
LAN	IO	Count: 1 Cable length [m]: >3m Direction: IO Service only: No Shielded: Yes	LAN CAT6; used 5 m and 1 m LAN Port with PoE (n)
SD card port	IO	Count: 1 Cable length [m]: 0 Direction: IO Service only: No Shielded: No	-

USB mini	IO	Count: 1 Cable length [m]: <3m Direction: IO Service only: Yes Shielded: Yes	USB port for configuration (a), port not exercised, not passively terminated
USB Typ A	IO	Count: 1 Cable length [m]: <3m Direction: IO Service only: No Shielded: Yes	USB OTG port for data dump (c)
Communication Port (Slot in +TNC P3)	IO	Count: 2 Cable length [m]: <3m Direction: IO Service only: No Shielded: Yes	port not exercised, not passively terminated Slot for third party modules (h,i)
Description:			
AC	AC mains power input/output port		
DC	DC power input/output port		
IO	Input/Output port		
WNP	Wired network port		
NE	Non-electrical port		

1.2 Equipment Photos - Internal

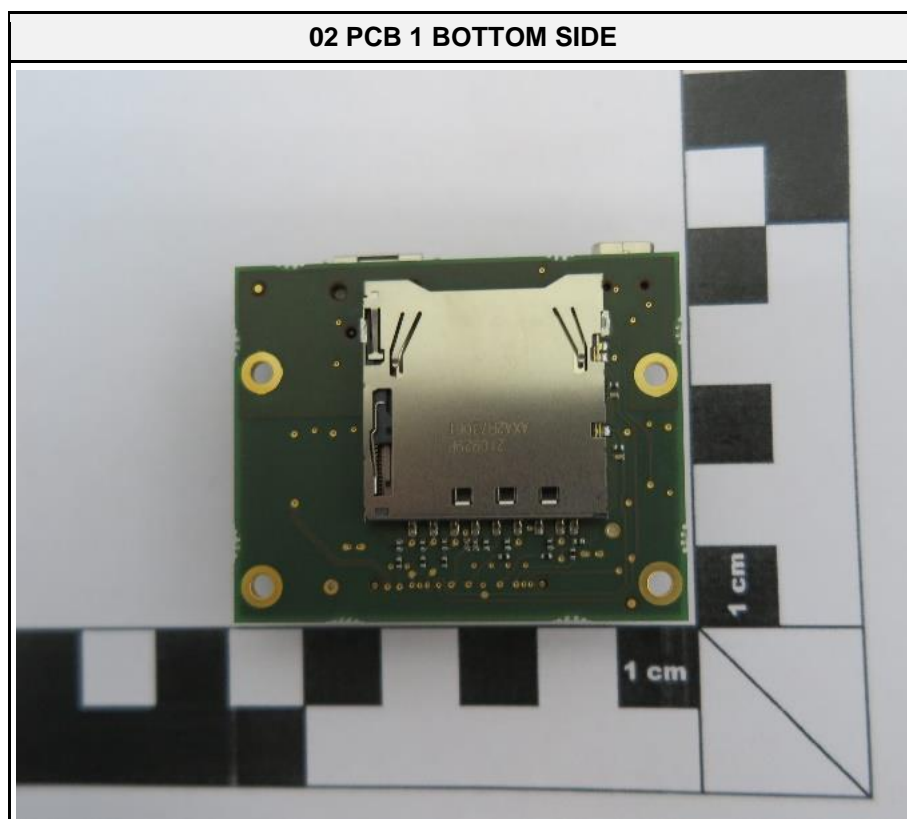
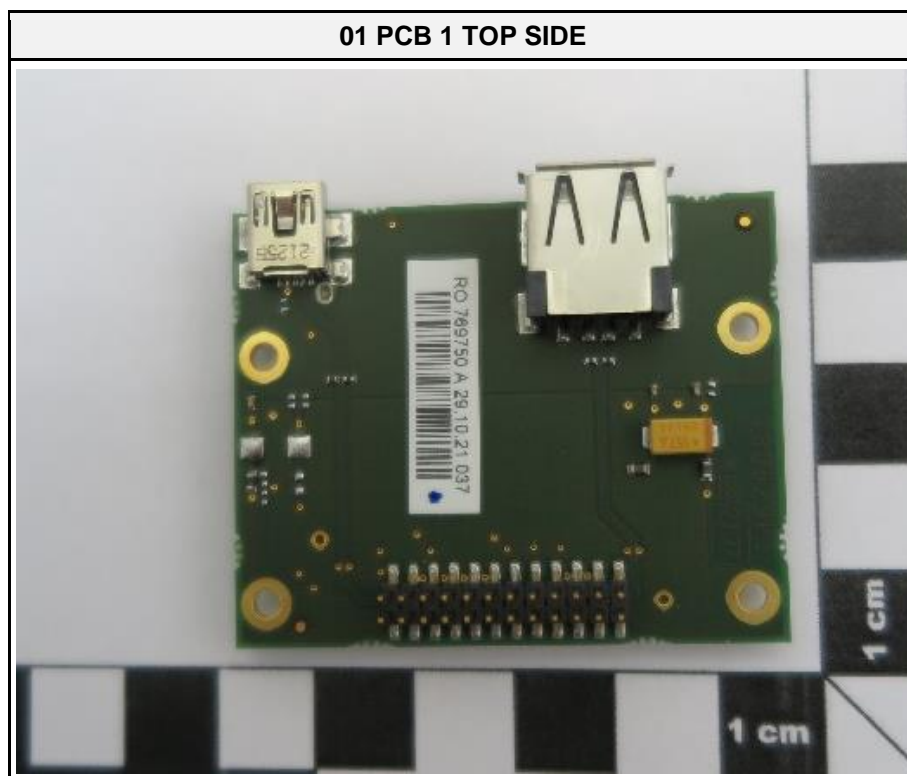

03 PCB 2 TOP SIDE

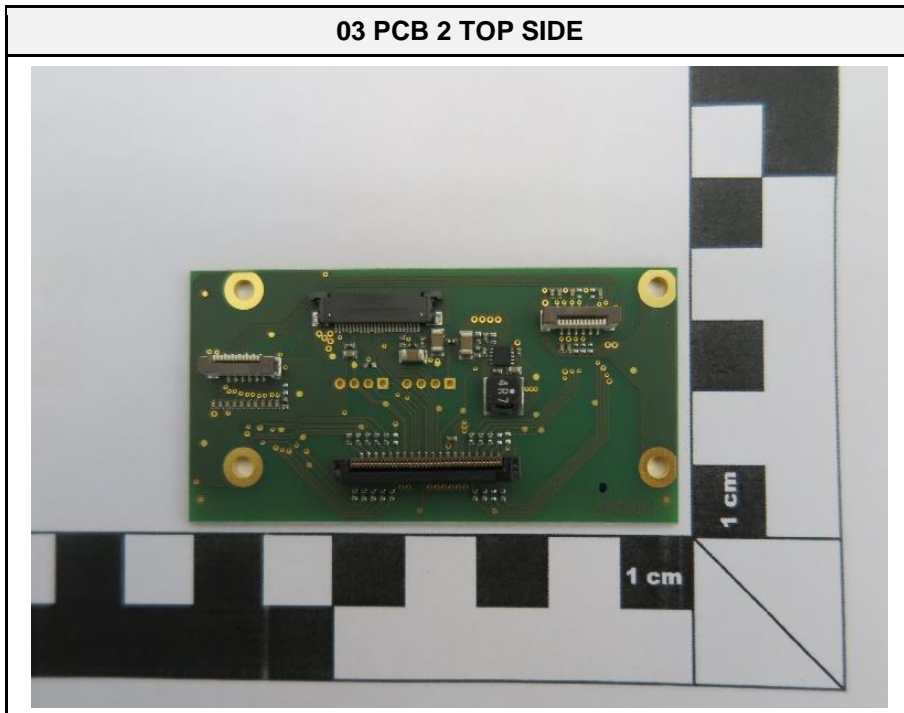

04 PCB 2 BOTTOM SIDE

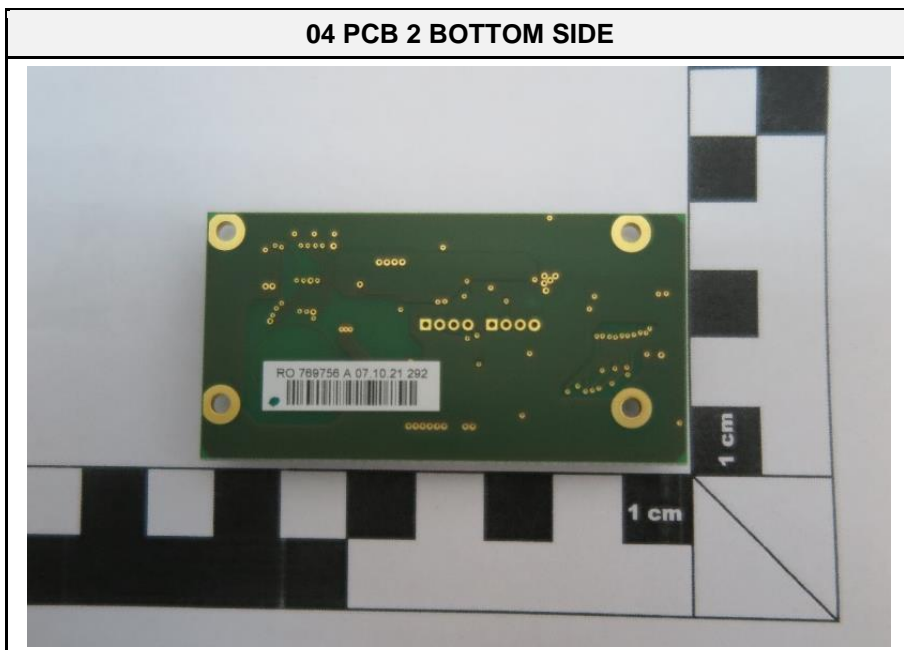

05 PCB 3 TOP SIDE

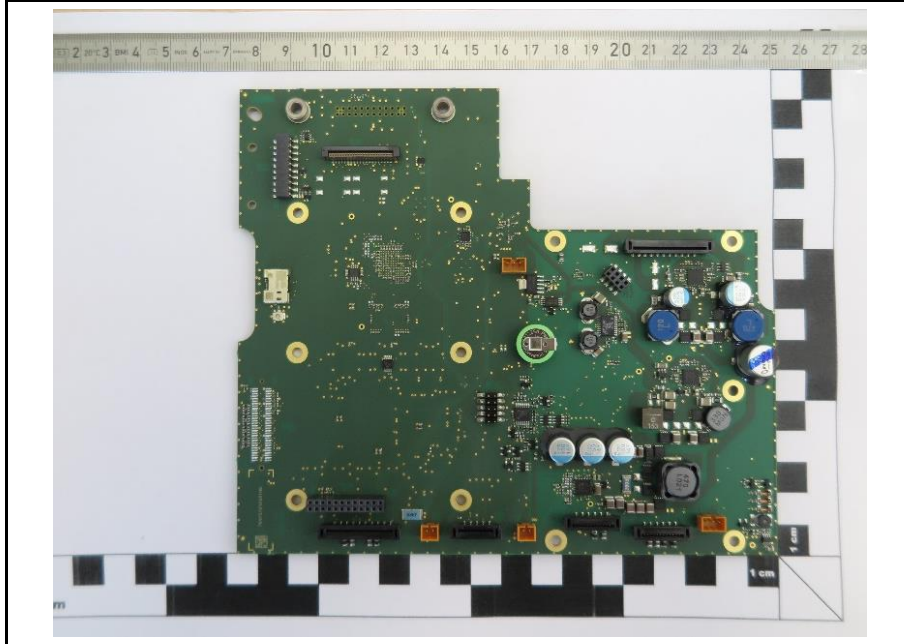

06 PCB 3 BOTTOM SIDE

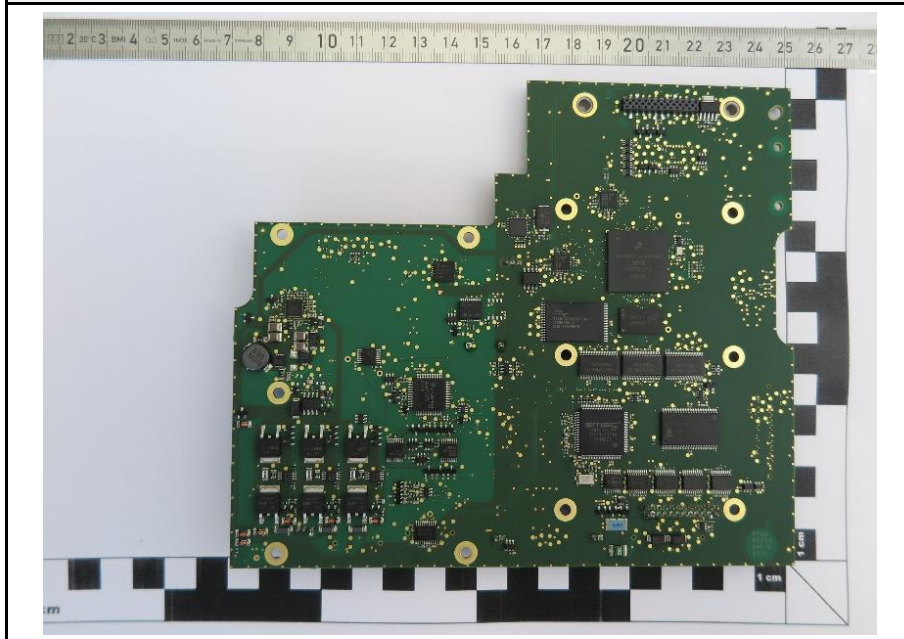

07 PCB 4 TOP SIDE

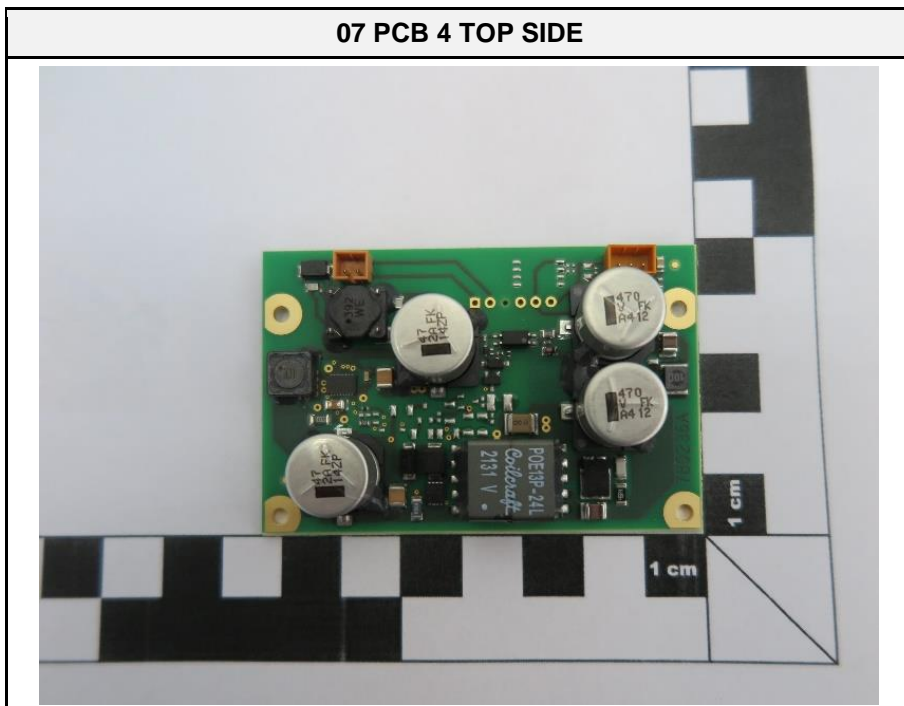

08 PCB 4 BOTTOM SIDE

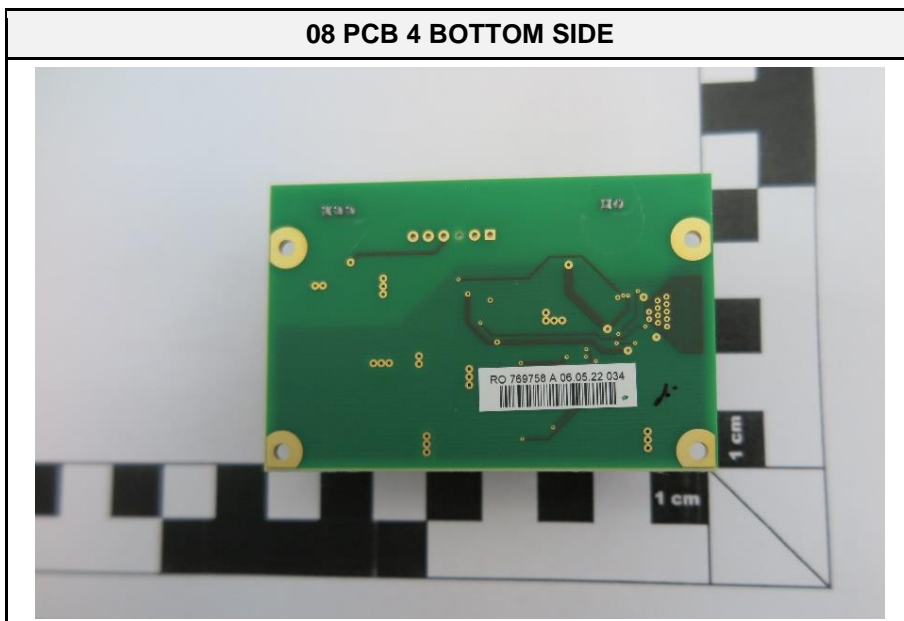

09 PCB 5 TOP SIDE

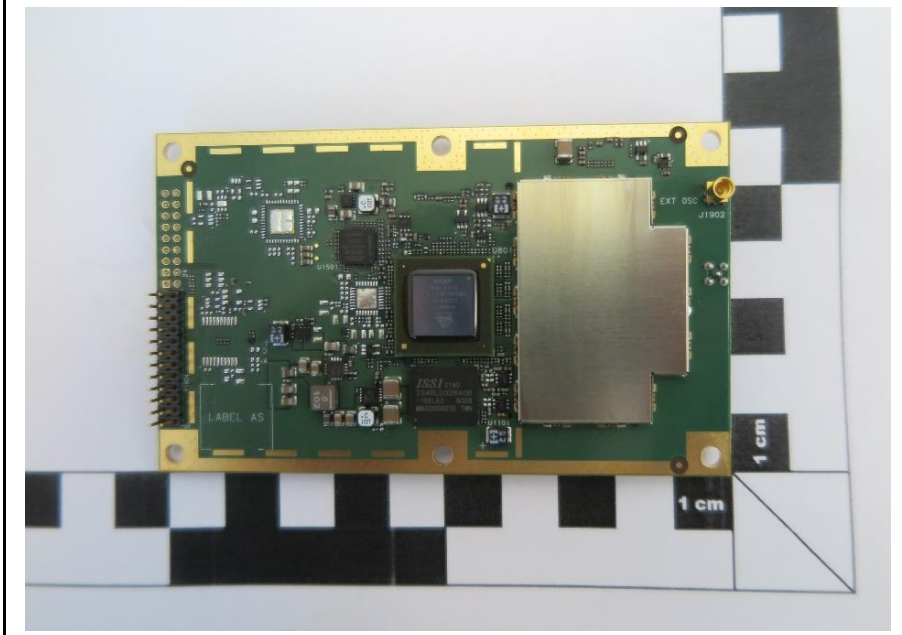

10 PCB 5 BOTTOM SIDE



11 PCB 6 TOP SIDE

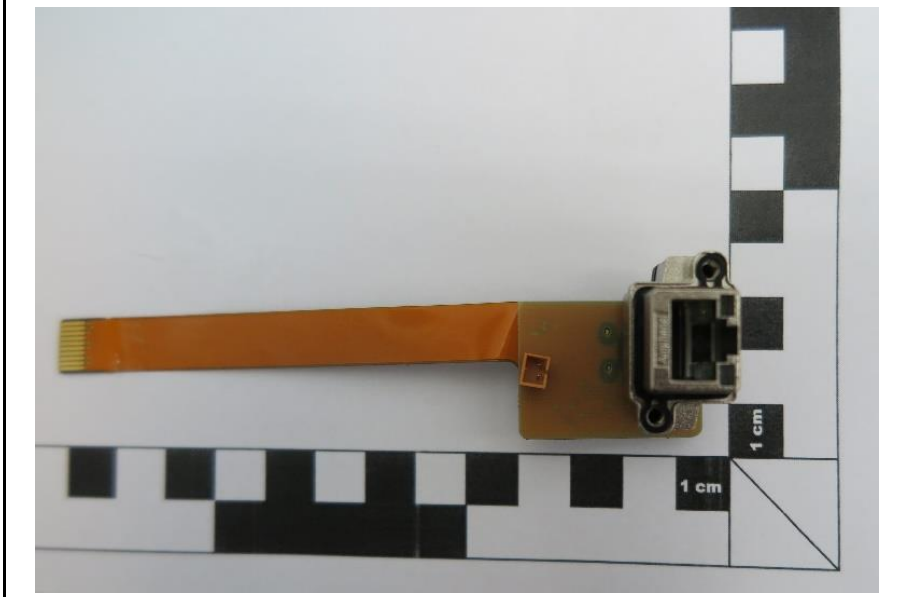

12 PCB 6 BOTTOM SIDE

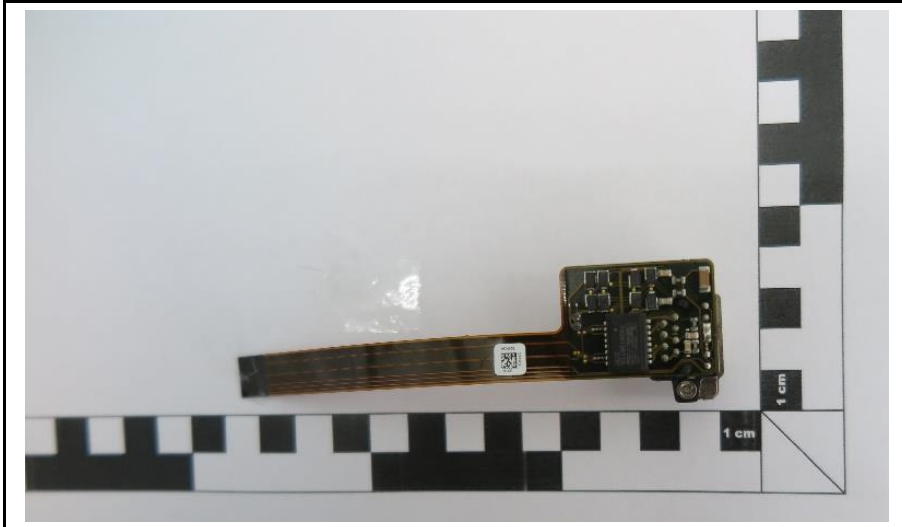

1.3 Equipment Photos - External

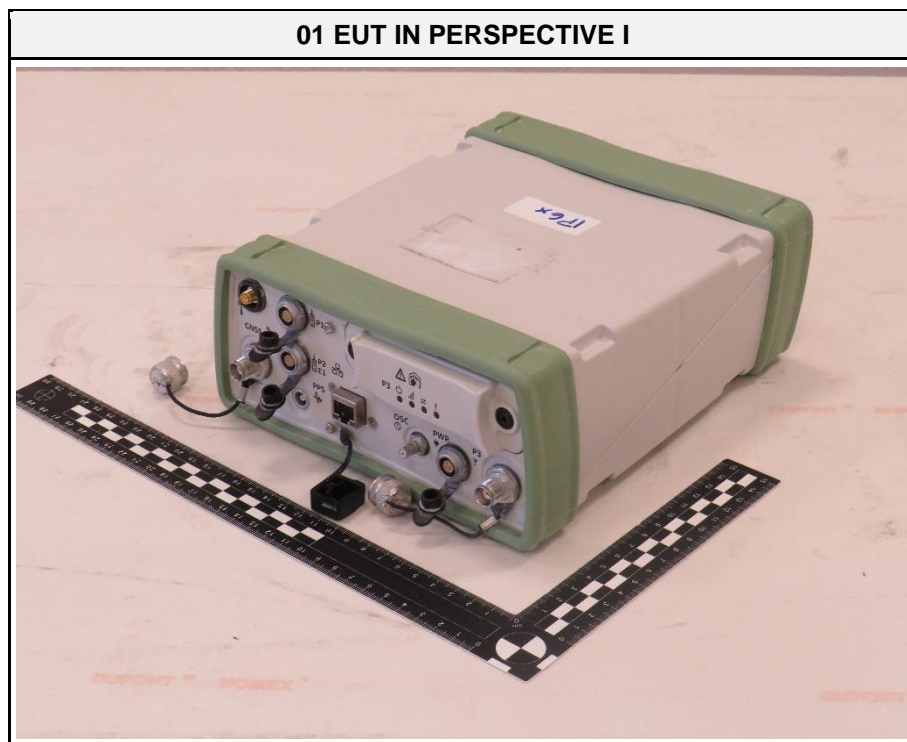

03 EUT FRONT SIDE



04 EUT FRONT SIDE WITH OPEN BATTERY SLOT



05 EUT FRONT SIDE WITHOUT BATTERY



06 EUT RIGHT SIDE



07 EUT LEFT SIDE



08 EUT TOP SIDE



10 EUT REAR SIDE WITH OPEN SLOT



11 EUT Label cutout

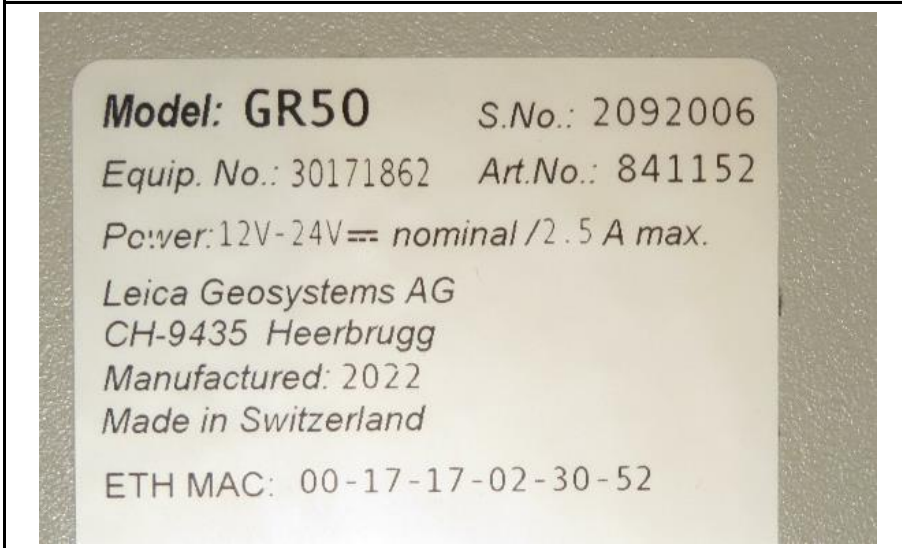

12 EUT BATTERY

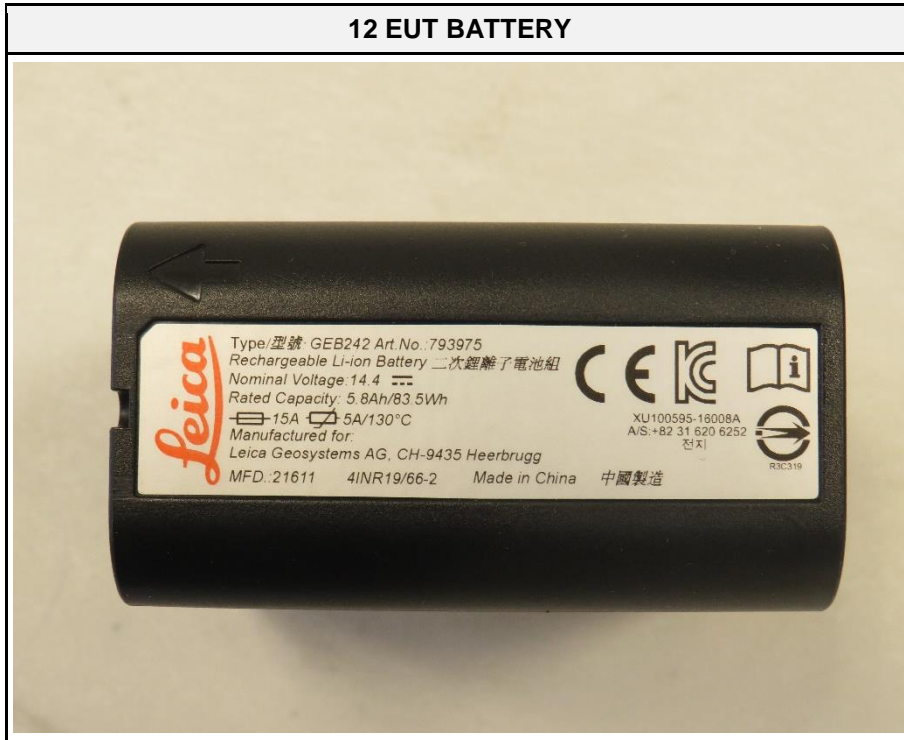

13 EUT BLUETOOTH LE ANTENNA



14 EUT GNSS ANTENNA

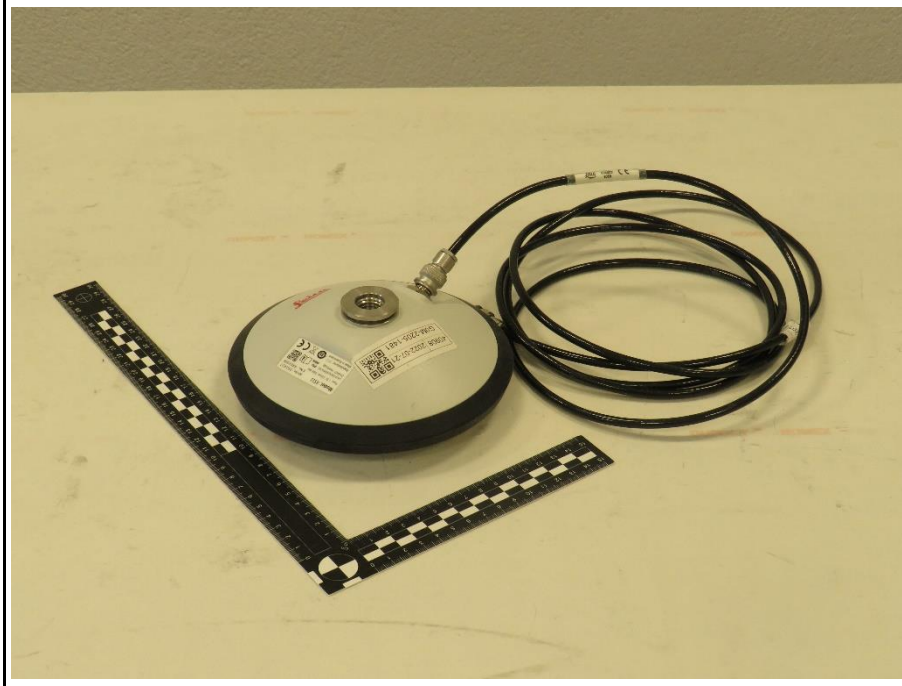

15 EUT GNSS ANTENNA FOCUS



16 GNSS ANTENNA LABEL



17 EUT WITH AC/DC-ADAPTER

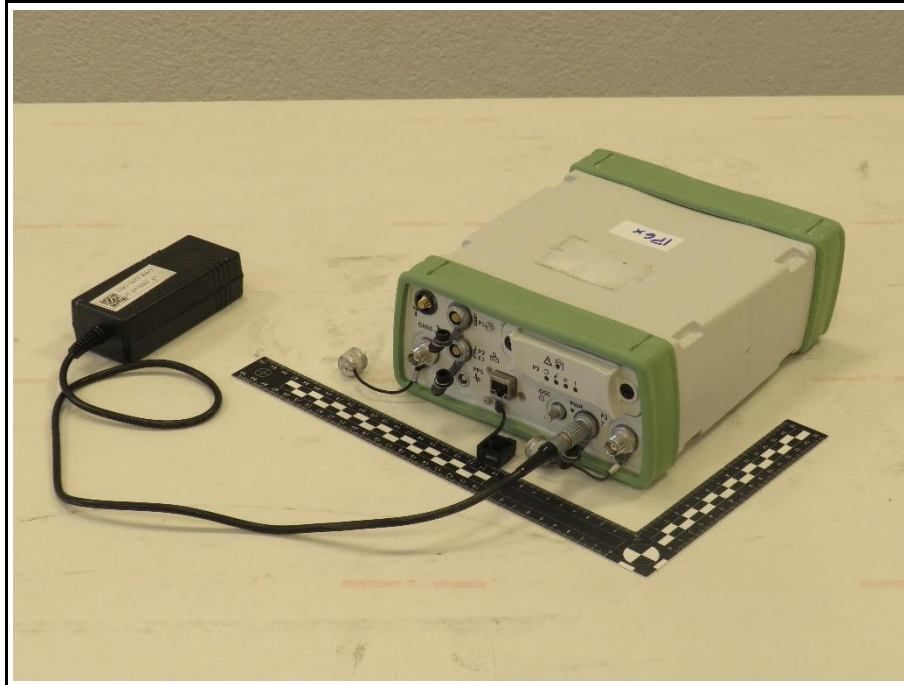

18 AC/DC-ADAPTER

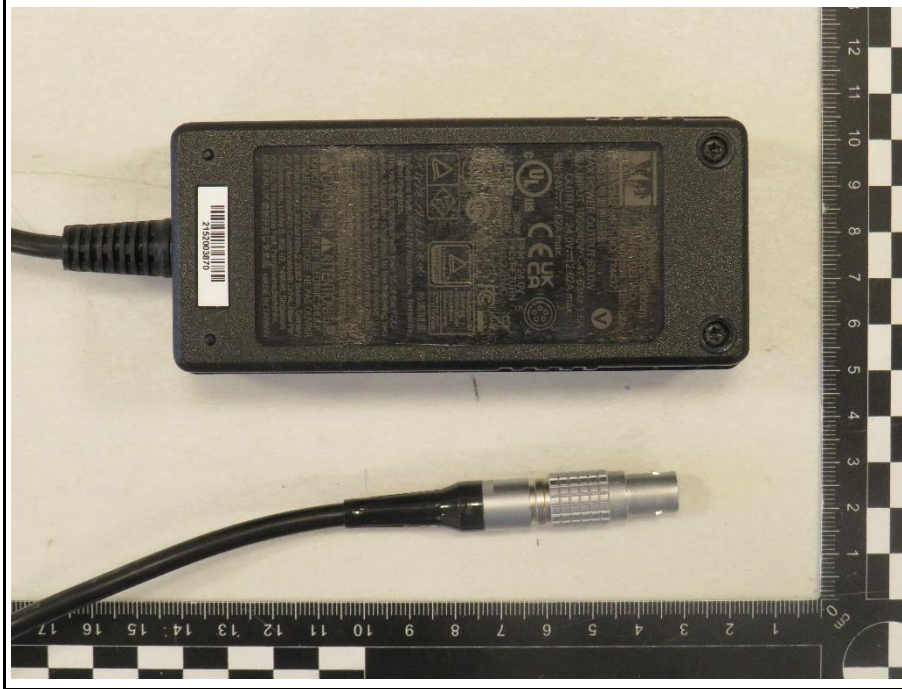



19 AC/DC-ADAPTER LABEL



20 EUT WITH SUPPORT EQUIPMENT



21 EUT Label (Draft)

Model: GR50	Art.No.: 841152
Equip. No.: 12345678	S.No.: 1234567
Leica Geosystems AG	
CH-9435 Heerbrugg	
Manufactured:	
Made in	
Power: 12V - 24V \equiv nominal / 2.4A max.	IP67
ETH MAC: 00 - 00 - 00 - 00 - 00 - 00	IP68
BT MAC: 00 - 00 - 00 - 00 - 00 - 00	
FCC ID: RFD-GR50BT	
IC: 3177A-GR50BT	

1.4 Support Equipment

Product Type	Device	Manufacturer	Model	Comment
CBL	Lemo Cable	Leica Geosystems	GEV233 (767 898)	Customer Equipment; Cable for third party sensors incl. loop back Hubner & Suhner 33065 Length 1.5 m
CBL	OSC Cable	Leica Geosystems	GEV169 (733 293)	Customer Equipment; Cable for oscillator input Length 2m Sample 40880
CBL	Serial Cable	-	GEV160 (733 280)	Customer Equipment; Cable for serial communication Length 2.5 m Sample 40881
CBL	LAN Cable	Datwyler	Cat. 6e S/FTP	Customer Equipment; RJ45 Length 5 m Sample 40868
AE	USB Stick	Sandisk	Ultra Fit 32GB	Customer Equipment; USB Stick 32GB, for Data Backup
AE	Laptop	HP	Z Book 15	Customer Equipment
SW	GNSS Viewer	-	VisualGPSView	-
AE	Battery	Leica	GEB242	Customer Equipment; 14.4V DC Art.-No. 793975 Sample 40902
AE	Optical link	icron	USB Ranger 2324	Customer Equipment; 2x Transceiver, 1 optical fiber 40897
CBL	USB A cable	-	-	Customer Equipment; Customer part Length 1.5 m 40899
CBL	Antenna cable	-	-	Customer Equipment; Coaxial cable 50 Ohm Length 2.5 m Sample 40905

CBL	USB A cable	-	-	Customer Equipment; Customer part Length 1.5 m 40899
CBL	Antenna cable	-	-	Customer Equipment; Coaxial cable 50 Ohm Length 2.5 m Sample 40905
AE	PoE injector	Microsemi	PowerDsine 3001GB	Eurofins product service GmbH
AE	Antenna 1	Leica	AS11 (892 561)	Customer Equipment; GNSS Antenna
AE	Antenna 2	Leica	GEV263 (762 858)	Customer Equipment; Bluetooth / WLAN Antenna
AE	Memory Card	Leica	MSD	Customer Equipment; SD Card
MON	Spectrum Analyser	Rohde&Schwarz	FPL1007	EF01682*
Description: *Monitoring intentional and unintentional transmission (carrier only)				

AE	Auxiliary Equipment
SIM	Simulator
MON	Monitoring Equipment
CBL	Connecting Cable
SW	Software
Comment: --	

1.5 Operational Modes

Mode #	Description
1	EUT receives second by second local GNSS position data from satellite. EUT sends/receives second by second status information to/from Laptop via Bluetooth LE connection. EUT sends windows ping (32 Bytes/s) to laptop via LAN connection every second. Serial connection to send position data and connect additional sensor/device parts second-by-second. Data will be write permanently to SD card and read back, the checksum will be compared.
Comment: --	

1.6 EUT Configuration

Configuration #	Description
1	<p>EUT is powered 120 V AC via dedicated AC/DC-Adapter. AC/DC-Adapter is powered via external laboratory power supply. Internal battery is charging and battery level is between 20 and 80 %. Shield of all shielded cables are connected on both ends with EUT/Support Equipment.</p> <p>For general connection and termination see block diagram page 32.</p>
2	<p>EUT is powered 14.4 V DC via Li-Ion battery (internally rechargeable). Battery level is between 20 and 80 %. Shield of all shielded cables are connected on both ends with EUT/Support Equipment.</p> <p>For general connection and termination see block diagram page 32.</p> <p>Dedicated AC/DC-Adapter is disconnected.</p>
3	<p>EUT is power 48 V DC via PoE injector. PoE injector is powered via external laboratory power supply. Internal battery is charging and battery level is between 20 and 80 %. Shield of all shielded cables are connected on both ends with EUT/Support Equipment to reference ground.</p> <p>For general connection and termination see block diagram page 32.</p> <p>Dedicated AC/DC-Adapter is disconnected.</p>
<p>Comment: Laptop interfaces optical links only.</p>	

Block diagram

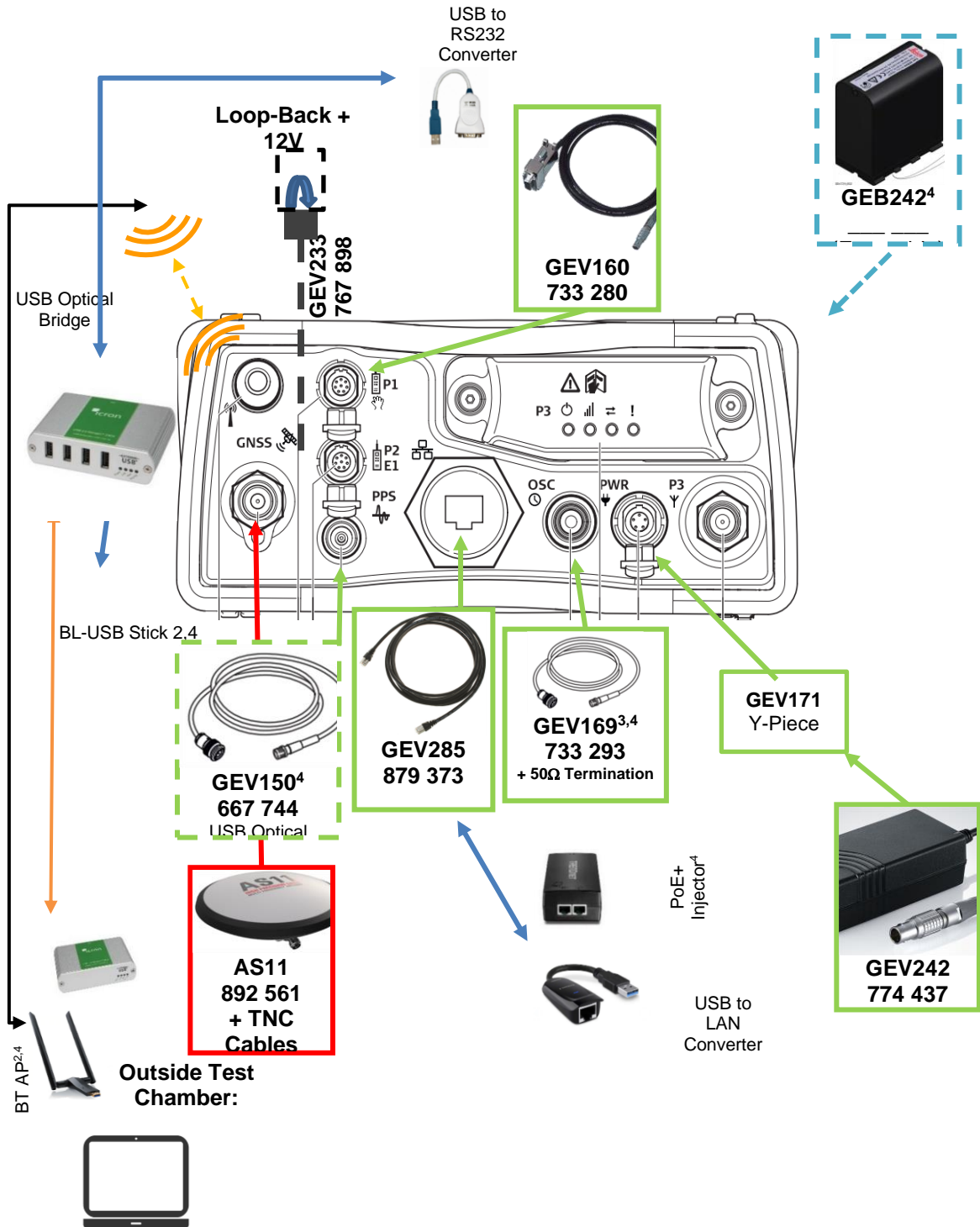

1.7 Sample emission level calculation

The following is a description of terms and a sample calculation, as appears in the radiated emissions data table. The numbers used in the calculation are for example only. There is no direct correlation to the specific data taken for the product described in this document:

Reading:

This is the reading obtained on the spectrum analyser in dBµV. Any external preamplifiers used are taken into account through internal analyser settings.

A.F.:

This is the antenna factor for the receiving antenna. It is a conversion factor, which converts electric fields strengths to voltages, which can be measured directly on the spectrum analyser. It is treated as a loss in dB. Cable losses have been included with the A.F. to simplify the calculations. The antenna factor is used in calculations as follows:

$$\text{Reading on Analyser (dB}\mu\text{V)} + \text{A.F. (dB/m)} = \text{Net field strength (dB}\mu\text{V/m)}$$

Net:

This is the net field strength measurement (as shown above).

Limit:

This is the FCC Class B radiated emission limit (in units of dBµV/m). The FCC limits are given in units of µV/m. The following formula is used to convert the units of µV/m to dBµV/m:

$$\text{Limit (dB}\mu\text{V/m)} = 20 \cdot \log(\mu\text{V/m})$$

Margin:

This is the margin of compliance below the FCC limit. The units are given in dB. A negative margin indicates the emission was below the limit. A positive margin indicates that the emission exceeds the limit.

Example only:

Reading + AF	=	Net Reading	:	Net reading - FCC limit	=	Margin
+21.5 dBµV + 26 dB/m		= 47.5 dBµV/m		47.5 dBµV/m - 57.0 dBµV/m		= -9.5 dB

2 Result Summary

Title 47 CFR Part 15B, ISED ICES-003 Issue 7				
Reference	Requirement	Reference Method	Result	Remarks
Emission				
FCC 15.109 ICES-003, 3.2.2	Radiated emissions	ANSI C63.4:2014 +A1:2017	PASS	-
FCC 15.107 ICES-003, 3.2.1	AC power line conducted emissions	ANSI C63.4:2014 +A1:2017	PASS	-
Comment:				

Possible Test Case Verdicts	
PASS	Test object does meet the requirements
FAIL	Test object does not meet the requirements
N/T	Required by standard but not tested
N/R	Not required by standard for the test object

2.1 Test Conditions and Results - Radiated emissions acc. to ANSI C63.4

2.1.1 Information

Test Information	
Reference	FCC 15.109, ICES-003, 3.2.2
Reference method	ANSI C63.4:2014+A1:2017 Section 8
Equipment class	Class B
Equipment type	Table top
Highest internal frequency [MHz]	2490
Measurement range	30 MHz to 13000 MHz
Temperature [°C]	24 ±5
Humidity [%]	48 ±10
Operator	Marko Neuner
Date	2022-08-10 and 2022-08-11

2.1.2 Setup

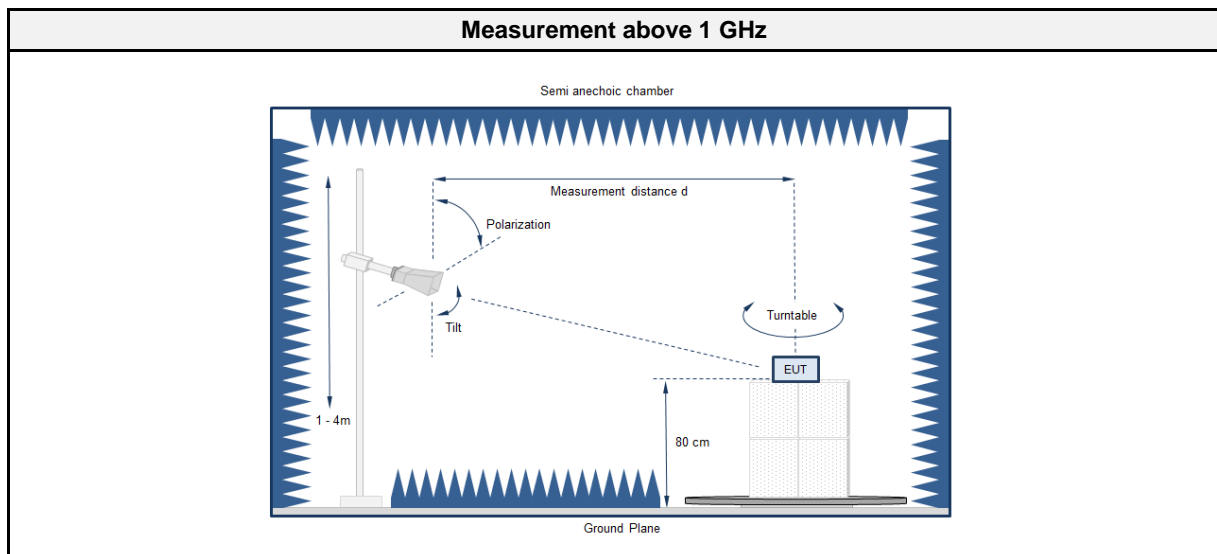
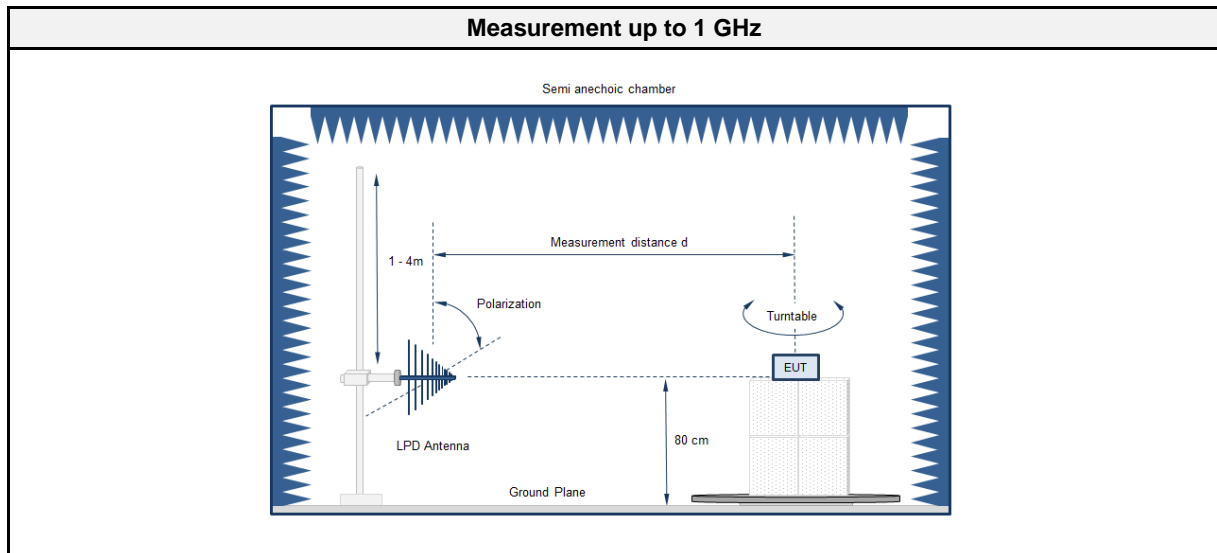

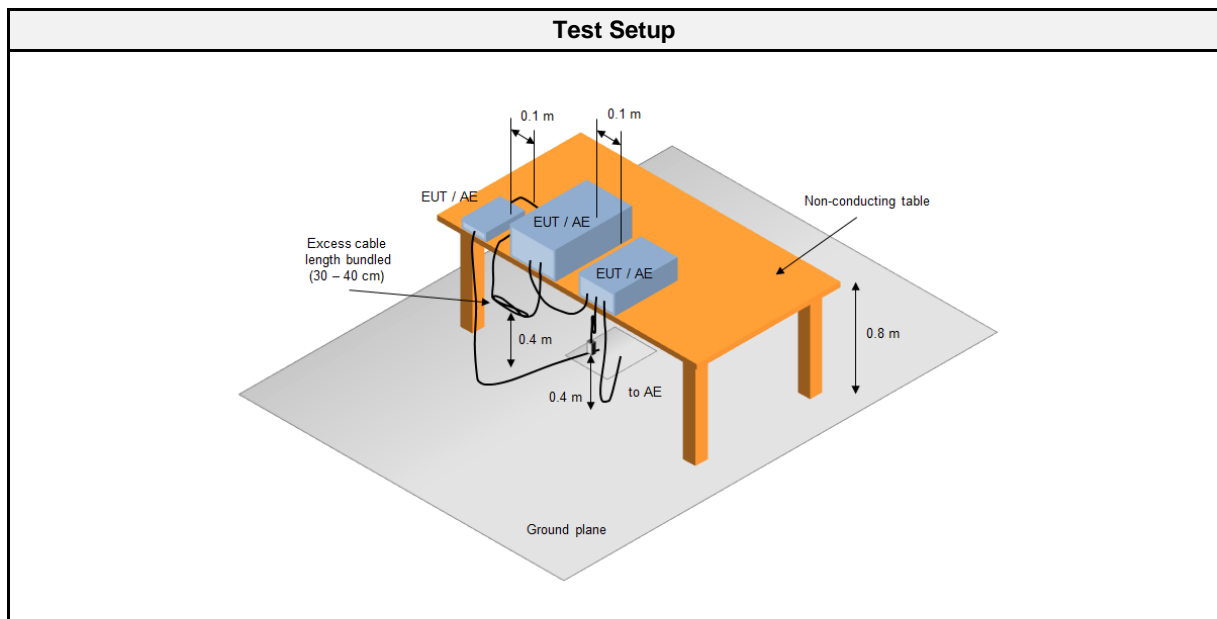
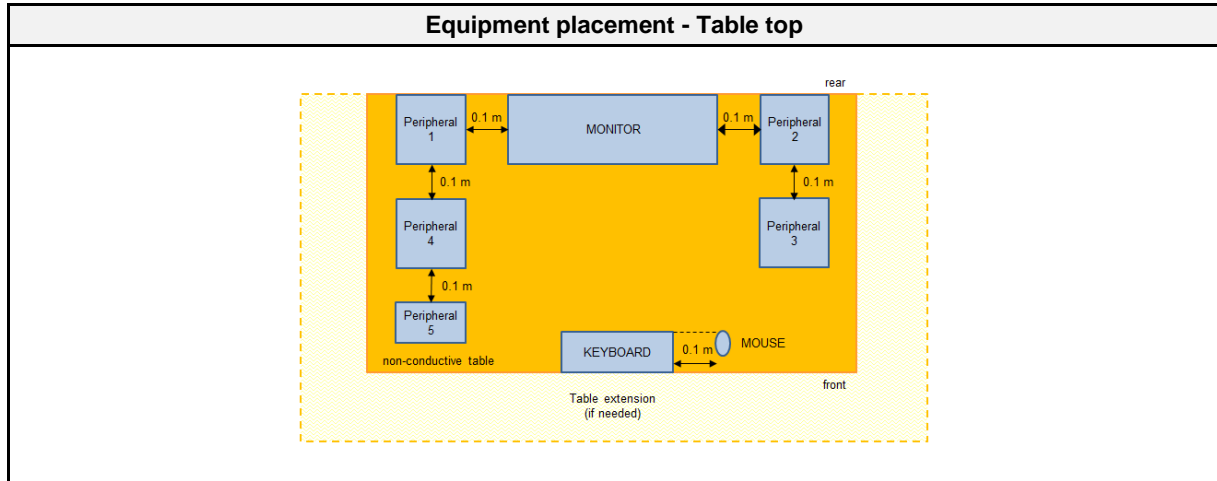

2.1.3 Equipment

Test Software			
Description	Manufacturer	Name	Version
EMC Software	DARE Instruments	Radimation	2020.1.8

Test Equipment					
Description	Manufacturer	Model	Identifier	Cal. Date	Cal. Due
Anechoic chamber (NSA)	Frankonia	AC1	EF00062	2021-02	2024-02
Anechoic chamber (SVSWR)	Frankonia	AC 1	EF01011	2022-06	2025-06
Programmable AC Source	Chroma ATE Inc.	61604	EF01068	2021-07	2023-07
EMI Test Receiver	Keysight	N9038A-526/WXP	EF01070	2021-07	2023-01
Biconical Antenna	R&S	HK 116	EF00030	2021-05	2024-05
LPD Antenna	R&S	HL 223	EF00187	2022-06	2025-06
Horn Antenna	Schwarzbeck	BBHA9120D	EF00018	2019-10	2022-10
Climatic Sensor	Embedded Data Systems, LLC.	2800100000254 17E	EF01054	2022-04	2023-04

2.1.4 Procedure

Exploratory measurement
<ol style="list-style-type: none"> 1. The EUT was placed on a non-conductive table at a height of 0.8m. 2. The EUT and support equipment, if needed, were set up to simulate typical usage. 3. Cables, of type and length specified by the manufacturer, were connected to at least one port of each type and were terminated by a device or simulating load of actual usage. 4. The antenna was placed at a distance of 3 or 10 m. 5. The received signal was monitored at the measurement receiver. 6. This procedure has to be performed in both antenna polarizations, horizontal and vertical. 7. The arrangement of the equipment with the maximum emission level is shown on the setup picture at item 2.1.2

Final measurement
<ol style="list-style-type: none"> 1. The EUT was placed on a 0.8 m non-conductive table at a 3 m distance from the receive antenna. The antenna output was connected to the measurement receiver. 2. A biconical antenna was used for the frequency range 30 – 200 MHz, a logarithmic periodical antenna was used for the frequency range from 200 – 1000 MHz. Above one 1 GHz a Double Ridged Broadband Horn antenna was used. The antenna was placed on an adjustable height antenna mast. 3. The EUT and cable arrangement were based on the exploratory measurement results. 4. Emissions were maximized at each frequency by rotating the EUT and adjusting the receive antenna height and polarization. The maximum values were recorded. 5. The test data of the worst-case conditions were recorded and shown on the next pages.

2.1.5 Limits

Class B @ 3 m		
Frequency [MHz]	Detector	Limit [dB μ V/m]
30 - 88	Quasi-peak	40
88 - 216	Quasi-peak	43.5
216 - 960	Quasi-peak	46
960 - 1000	Quasi-peak	54
> 1000	Peak Average	74 54

2.1.6 Results

Test Results			
Operational mode	EUT Configuration	Verdict	Remark
1	1	PASS	EUT 1 Sample 40910; 120 V AC / 60 Hz
1	2	PASS	EUT 1 Sample 40910
1	3	PASS	EUT 1 Sample 40910;
Comment: AC Mains cable length is 1 m and LAN cable length is 3 m. All other cable length see 1.4 Support Equipment table.			

2.1.7 Setup Photos

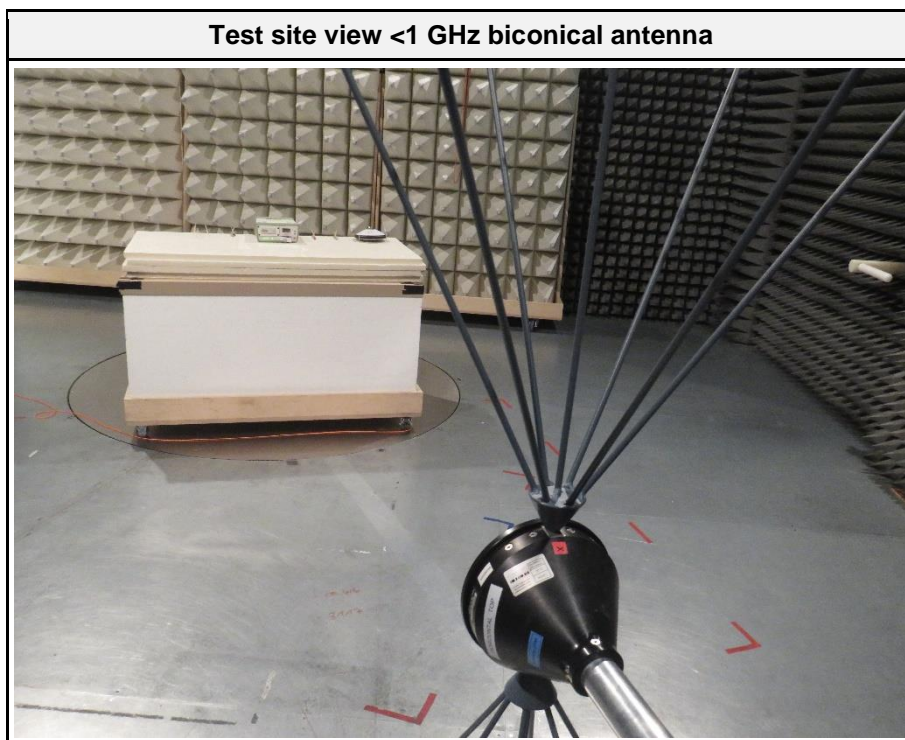
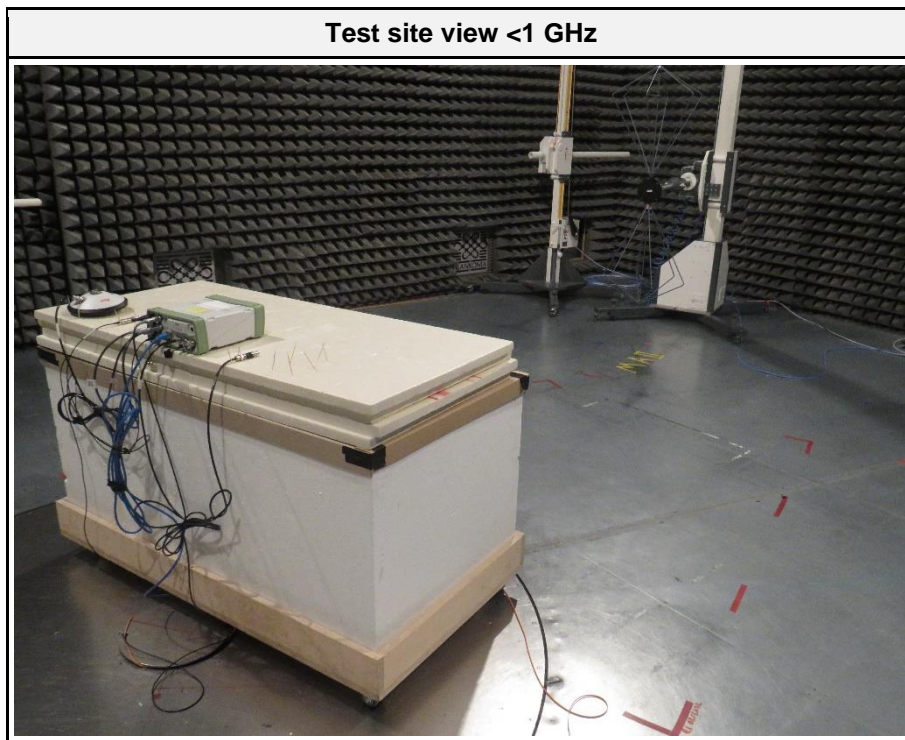

Test setup equipment table

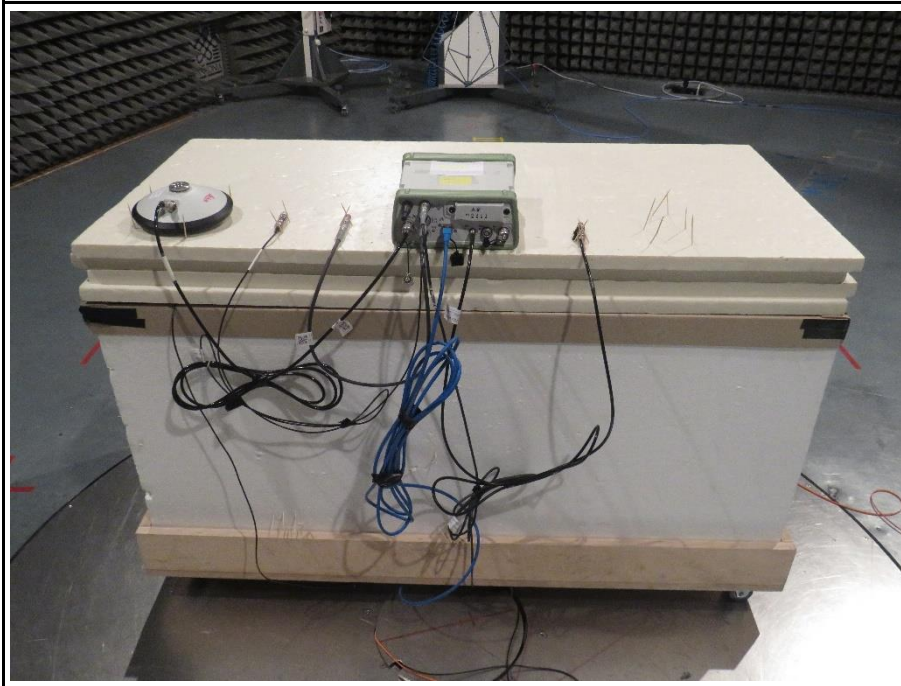

Test site view >1 GHz

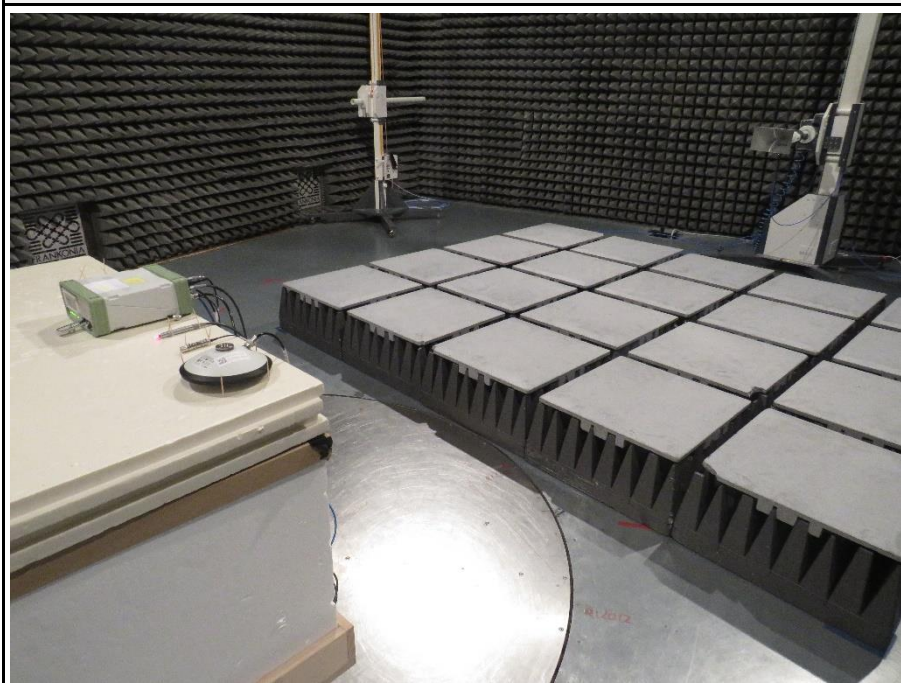

Test site view >1 GHz horn antenna

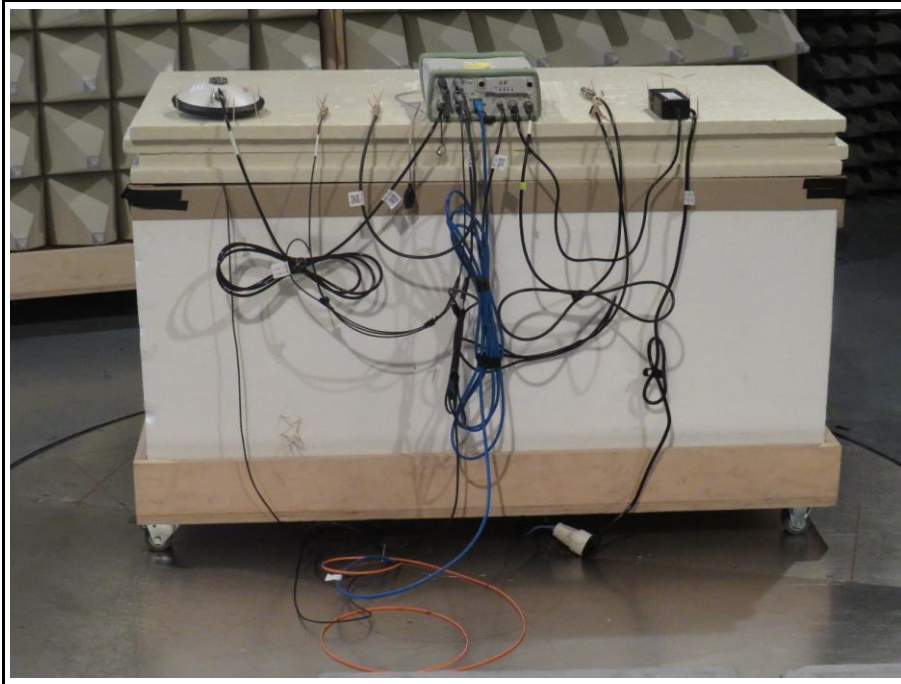

Test site view >1 GHz horn antenna horizontal

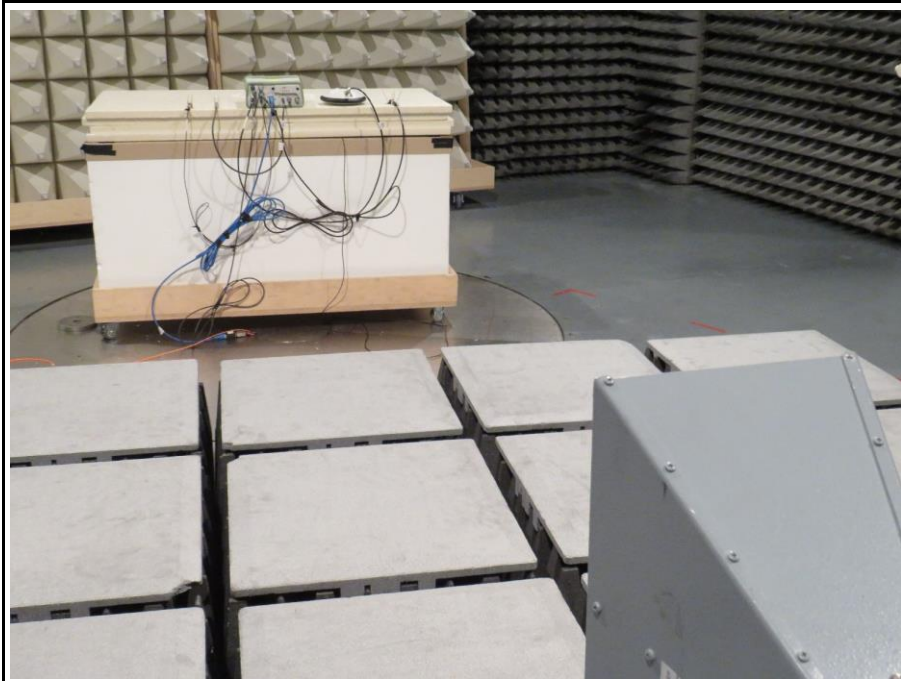

2.1.8 Records

Radiated emissions according to FCC part 15B

Project Number: G0M-2205-1481
 Applicant: Leica Geosystems AG
 Model Description: GNSS Reference Server
 Model: GR50
 Test Sample ID: 40910
 Test Site: Eurofins Product Service GmbH
 Operator: Mr. Neuner
 Test Date: 2022-08-11
 Operating Conditions: ambient temperature: 24 °Celsius
 power input: 120 V AC / 60 Hz
 Antenna: Rohde & Schwarz HK 116, Vertical
 Measurement Distance: 3m
 Operational Mode: 1
 EUT Configuration: 1
 Note 1: -

Index 40

RadiMation

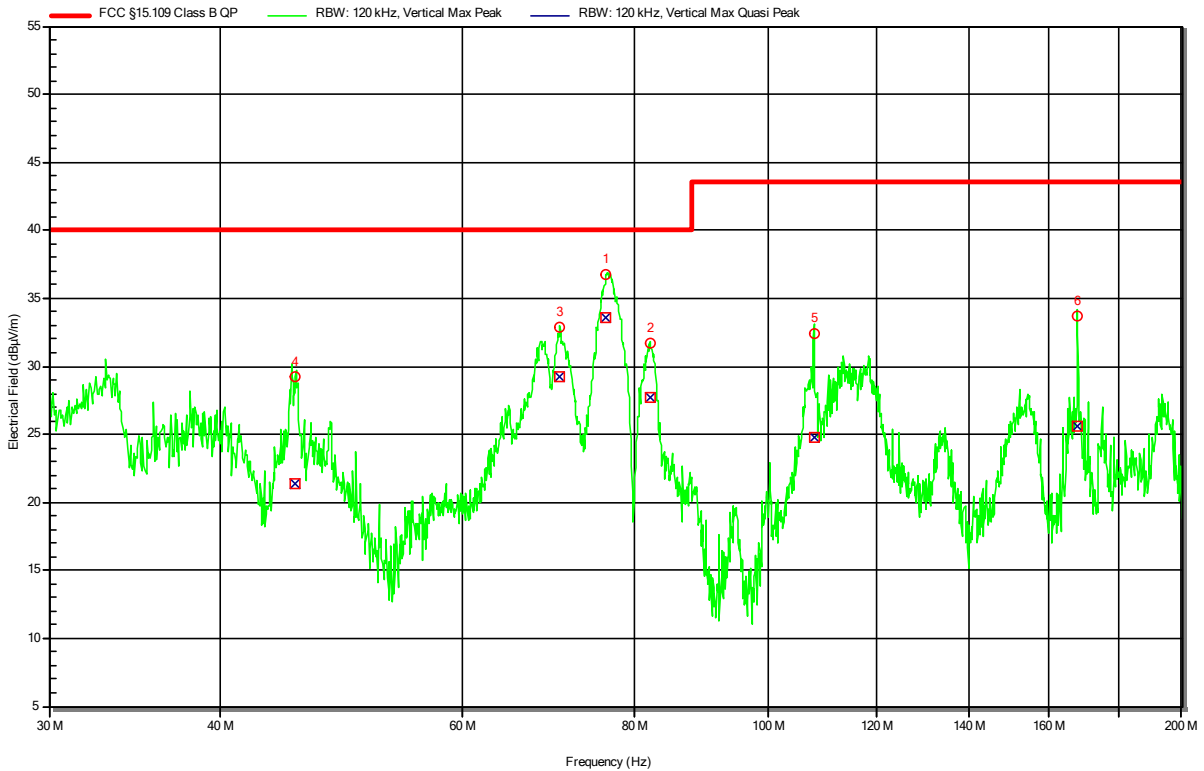

Peak Number	Frequency	Quasi-Peak	Quasi-Peak Limit	Quasi-Peak Difference	Quasi-Peak Status	Angle	Height
1	76.325 MHz	33.59 dBµV/m	40 dBµV/m	-6.41 dB	Pass	-121 degrees	1 m
2	82.08 MHz	27.71 dBµV/m	40 dBµV/m	-12.29 dB	Pass	-121 degrees	1 m
3	70.535 MHz	29.22 dBµV/m	40 dBµV/m	-10.78 dB	Pass	-121 degrees	1 m
4	45.308 MHz	21.35 dBµV/m	40 dBµV/m	-18.65 dB	Pass	-121 degrees	1 m
5	108.021 MHz	24.84 dBµV/m	43.52 dBµV/m	-18.69 dB	Pass	-121 degrees	1 m
6	167.992 MHz	25.65 dBµV/m	43.52 dBµV/m	-17.87 dB	Pass	-121 degrees	1 m

Radiated emissions according to FCC part 15B

Project Number: G0M-2205-1481
 Applicant: Leica Geosystems AG
 Model Description: GNSS Reference Server
 Model: GR50
 Test Sample ID: 40910
 Test Site: Eurofins Product Service GmbH
 Operator: Mr. Neuner
 Test Date: 2022-08-11
 Operating Conditions: ambient temperature: 24 °Celsius
 power input: 120 V AC / 60 Hz
 Antenna: Rohde & Schwarz HK 116, Horizontal
 Measurement Distance: 3m
 Operational Mode: 1
 EUT Configuration: 1
 Note 1: -

Index 41

RadiMation

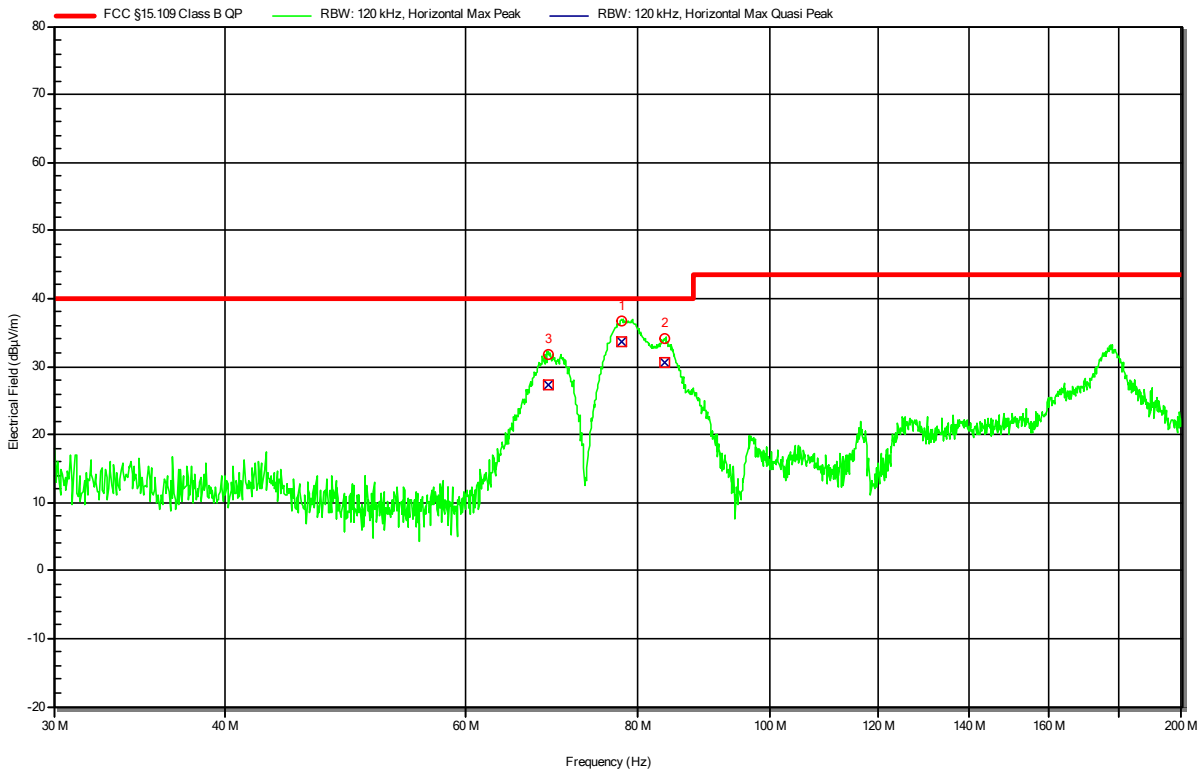

Peak Number	Frequency	Quasi-Peak	Quasi-Peak Limit	Quasi-Peak Difference	Quasi-Peak Status	Angle	Height
1	78.006 MHz	33.6 dBµV/m	40 dBµV/m	-6.4 dB	Pass	169 degrees	2.5 m
2	83.754 MHz	30.48 dBµV/m	40 dBµV/m	-9.52 dB	Pass	169 degrees	2.5 m
3	68.981 MHz	27.38 dBµV/m	40 dBµV/m	-12.62 dB	Pass	169 degrees	2.5 m

Radiated emissions according to FCC part 15B

Project Number: G0M-2205-1481
 Applicant: Leica Geosystems AG
 Model Description: GNSS Reference Server
 Model: GR50
 Test Sample ID: 40910
 Test Site: Eurofins Product Service GmbH
 Operator: Mr. Neuner
 Test Date: 2022-08-11
 Operating Conditions: ambient temperature: 24 °Celsius
 power input: 120 V AC / 60 Hz
 Antenna: Rohde & Schwarz HL 223, Vertical
 Measurement Distance: 3m
 Operational Mode: 1
 EUT Configuration: 1
 Note 1: -

Index 51

RadiMation

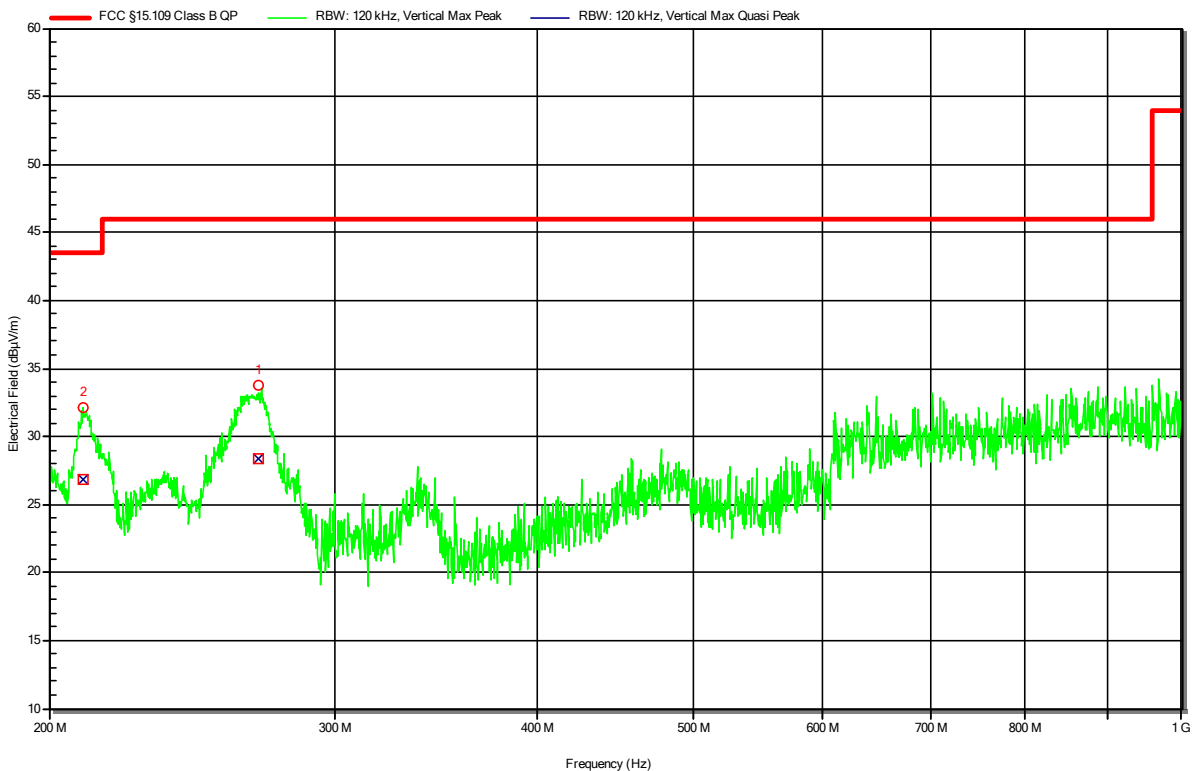

Peak Number	Frequency	Quasi-Peak	Quasi-Peak Limit	Quasi-Peak Difference	Quasi-Peak Status	Angle	Height
1	269.482 MHz	28.37 dBµV/m	46.02 dBµV/m	-17.66 dB	Pass	90 degrees	1 m
2	209.84 MHz	26.79 dBµV/m	43.52 dBµV/m	-16.74 dB	Pass	90 degrees	1 m

Radiated emissions according to FCC part 15B

Project Number: G0M-2205-1481
 Applicant: Leica Geosystems AG
 Model Description: GNSS Reference Server
 Model: GR50
 Test Sample ID: 40910
 Test Site: Eurofins Product Service GmbH
 Operator: Mr. Neuner
 Test Date: 2022-08-11
 Operating Conditions: ambient temperature: 24 °Celsius
 power input: 120 V AC / 60 Hz
 Antenna: Rohde & Schwarz HL 223, Horizontal
 Measurement Distance: 3m
 Operational Mode: 1
 EUT Configuration: 1
 Note 1: -

Index 50

RadiMation

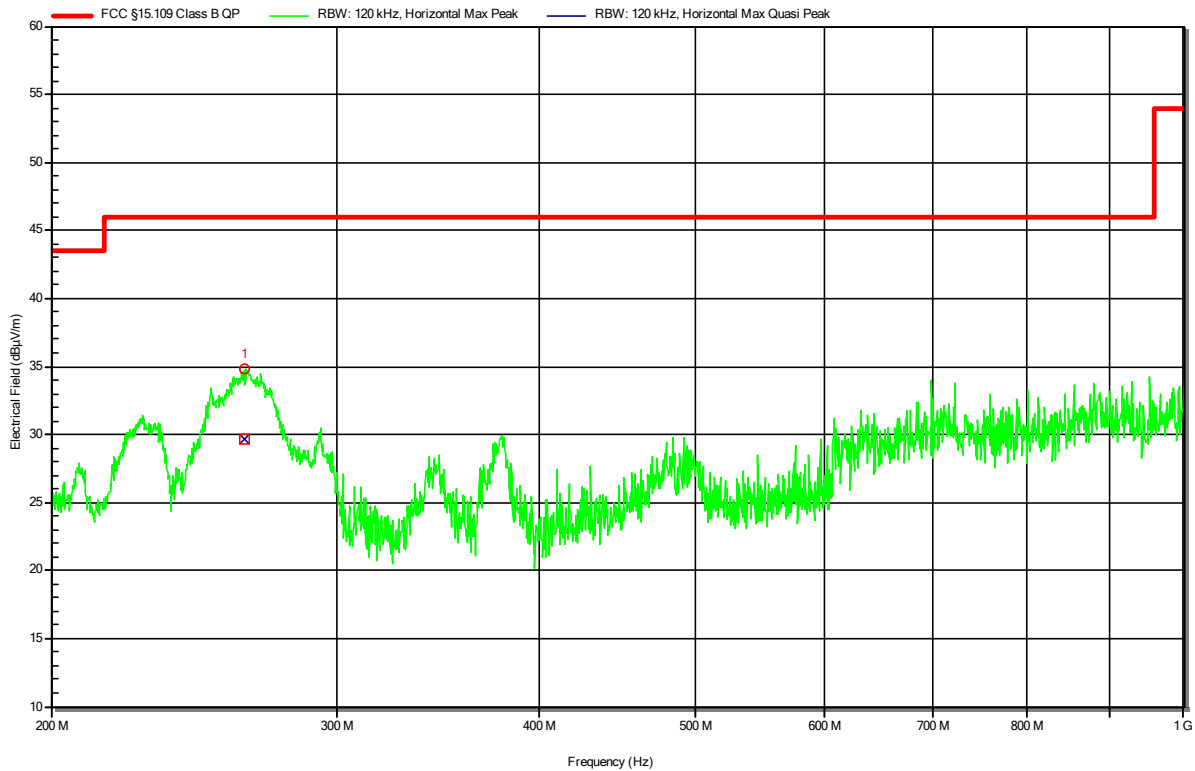

Peak Number	Frequency	Quasi-Peak	Quasi-Peak Limit	Quasi-Peak Difference	Quasi-Peak Status	Angle	Height
1	263.362 MHz	29.66 dBµV/m	46.02 dBµV/m	-16.36 dB	Pass	90 degrees	1 m

Radiated emissions according to FCC part 15B

Project Number: G0M-2205-1481
 Applicant: Leica Geosystems AG
 Model Description: GNSS Reference Server
 Model: GR50
 Test Sample ID: 40910
 Test Site: Eurofins Product Service GmbH
 Operator: Mr. Neuner
 Test Date: 2022-08-11
 Operating Conditions: ambient temperature: 24 °Celsius
 power input: 48 V DC via Power over LAN (PoE)
 Antenna: Rohde & Schwarz HK 116, Vertical
 Measurement Distance: 3m
 Operational Mode: 1
 EUT Configuration: 3
 Note 1: -

Index 44

RadiMation

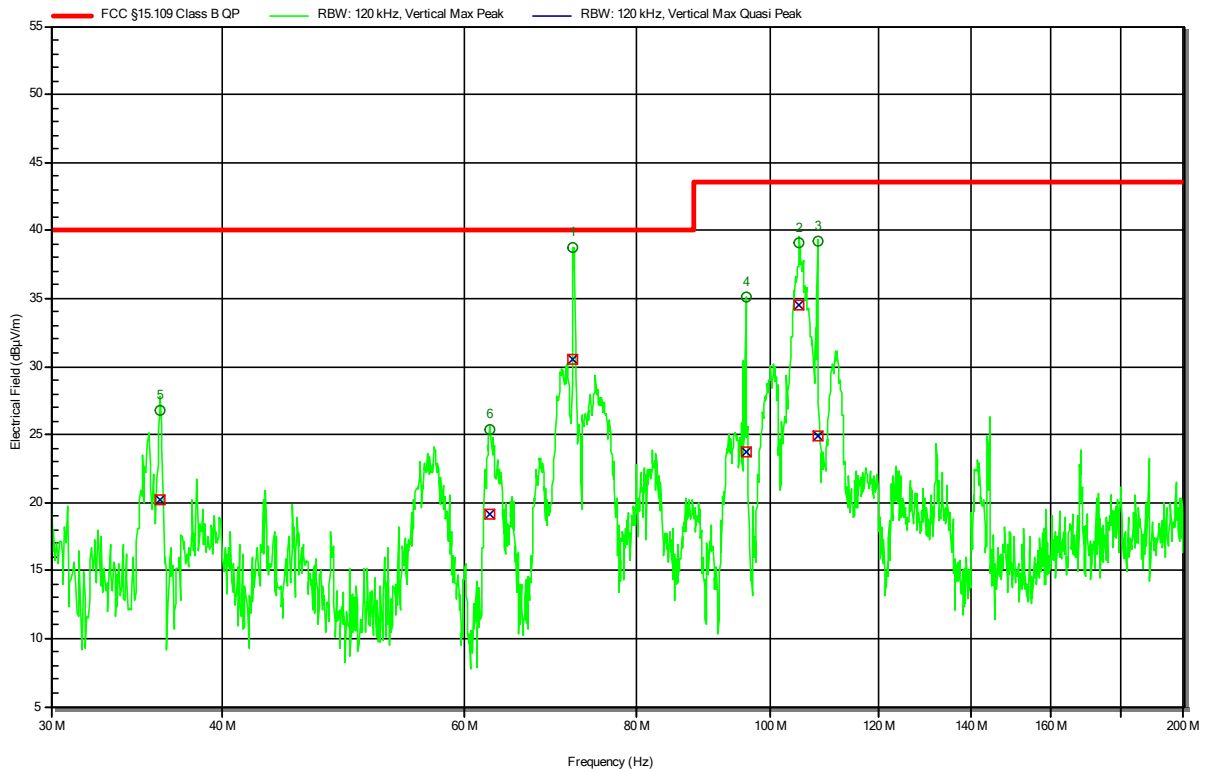

Peak Number	Frequency	Quasi-Peak	Quasi-Peak Limit	Quasi-Peak Difference	Quasi-Peak Status	Angle	Height
1	71.951 MHz	30.5 dBµV/m	40 dBµV/m	-9.5 dB	Pass	148 degrees	1.5 m
2	105.027 MHz	34.56 dBµV/m	43.52 dBµV/m	-8.96 dB	Pass	148 degrees	1.5 m
3	108.291 MHz	24.9 dBµV/m	43.52 dBµV/m	-18.62 dB	Pass	148 degrees	1.5 m
4	96.044 MHz	23.73 dBµV/m	43.52 dBµV/m	-19.79 dB	Pass	148 degrees	1.5 m
5	35.983 MHz	20.17 dBµV/m	40 dBµV/m	-19.83 dB	Pass	148 degrees	1.5 m
6	62.506 MHz	19.15 dBµV/m	40 dBµV/m	-20.85 dB	Pass	148 degrees	1.5 m

Radiated emissions according to FCC part 15B

Project Number: G0M-2205-1481
 Applicant: Leica Geosystems AG
 Model Description: GNSS Reference Server
 Model: GR50
 Test Sample ID: 40910
 Test Site: Eurofins Product Service GmbH
 Operator: Mr. Neuner
 Test Date: 2022-08-11
 Operating Conditions: ambient temperature: 24 °Celsius
 power input: 48 V DC via Power over LAN (PoE)
 Antenna: Rohde & Schwarz HK 116, Horizontal
 Measurement Distance: 3m
 Operational Mode: 1
 EUT Configuration: 3
 Note 1: -

Index 45

RadiMation

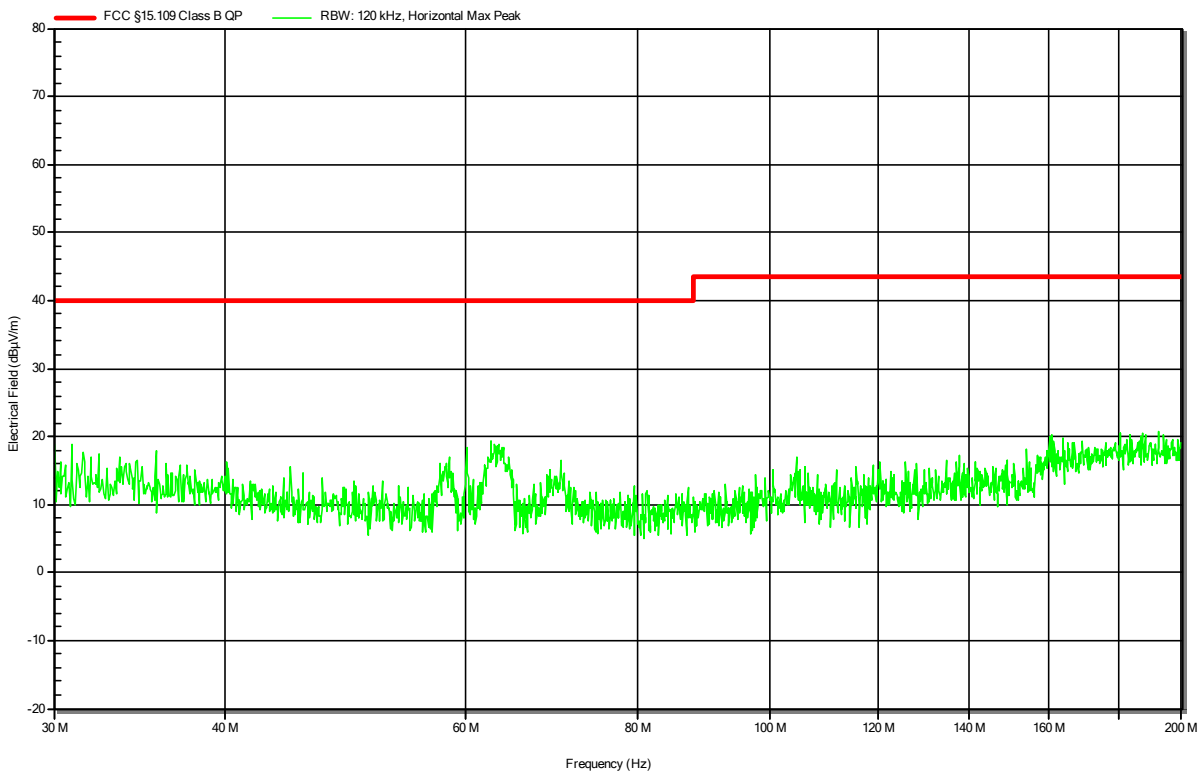

Radiated emissions according to FCC part 15B

Project Number: G0M-2205-1481
 Applicant: Leica Geosystems AG
 Model Description: GNSS Reference Server
 Model: GR50
 Test Sample ID: 40910
 Test Site: Eurofins Product Service GmbH
 Operator: Mr. Neuner
 Test Date: 2022-08-11
 Operating Conditions: ambient temperature: 24 °Celsius
 power input: 48 V DC via Power over LAN (PoE)
 Antenna: Rohde & Schwarz HL 223, Vertical
 Measurement Distance: 3m
 Operational Mode: 1
 EUT Configuration: 3
 Note 1: -

Index 47

RadiMation

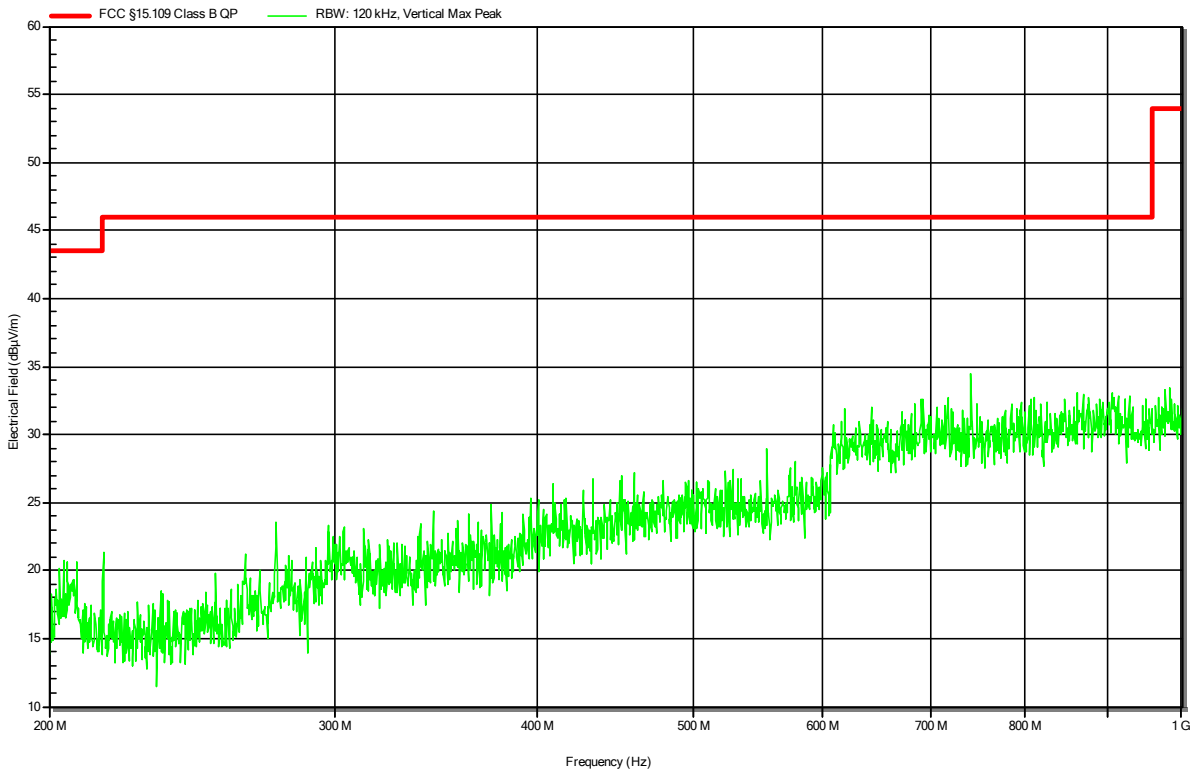

Radiated emissions according to FCC part 15B

Project Number: G0M-2205-1481
 Applicant: Leica Geosystems AG
 Model Description: GNSS Reference Server
 Model: GR50
 Test Sample ID: 40910
 Test Site: Eurofins Product Service GmbH
 Operator: Mr. Neuner
 Test Date: 2022-08-11
 Operating Conditions: ambient temperature: 24 °Celsius
 power input: 48 V DC via Power over LAN (PoE)
 Antenna: Rohde & Schwarz HL 223, Horizontal
 Measurement Distance: 3m
 Operational Mode: 1
 EUT Configuration: 3
 Note 1: -

Index 46

RadiMation

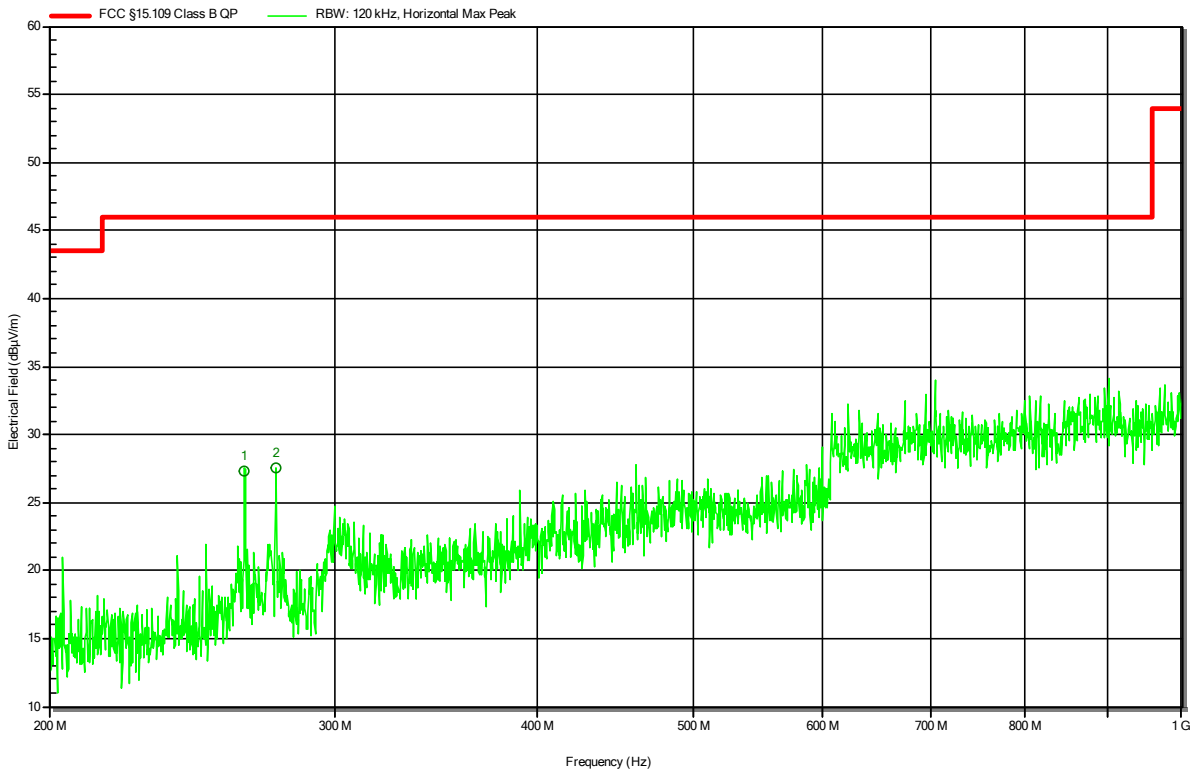

Peak Number	Frequency	Angle	Height
1	264.022 MHz	0 degrees	1 m
2	276.022 MHz	0 degrees	1 m

Radiated emissions according to FCC part 15B

Project Number: G0M-2205-1481
 Applicant: Leica Geosystems AG
 Model Description: GNSS Reference Server
 Model: GR50
 Test Sample ID: 40910
 Test Site: Eurofins Product Service GmbH
 Operator: Mr. Neuner
 Test Date: 2022-08-11
 Operating Conditions: ambient temperature: 24 °Celsius
 power input: 14.4 V DC via rechargeable lithium battery
 Antenna: Rohde & Schwarz HK 116, Vertical
 Measurement Distance: 3m
 Operational Mode: 1
 EUT Configuration: 2
 Note 1: -

Index 43

RadiMation

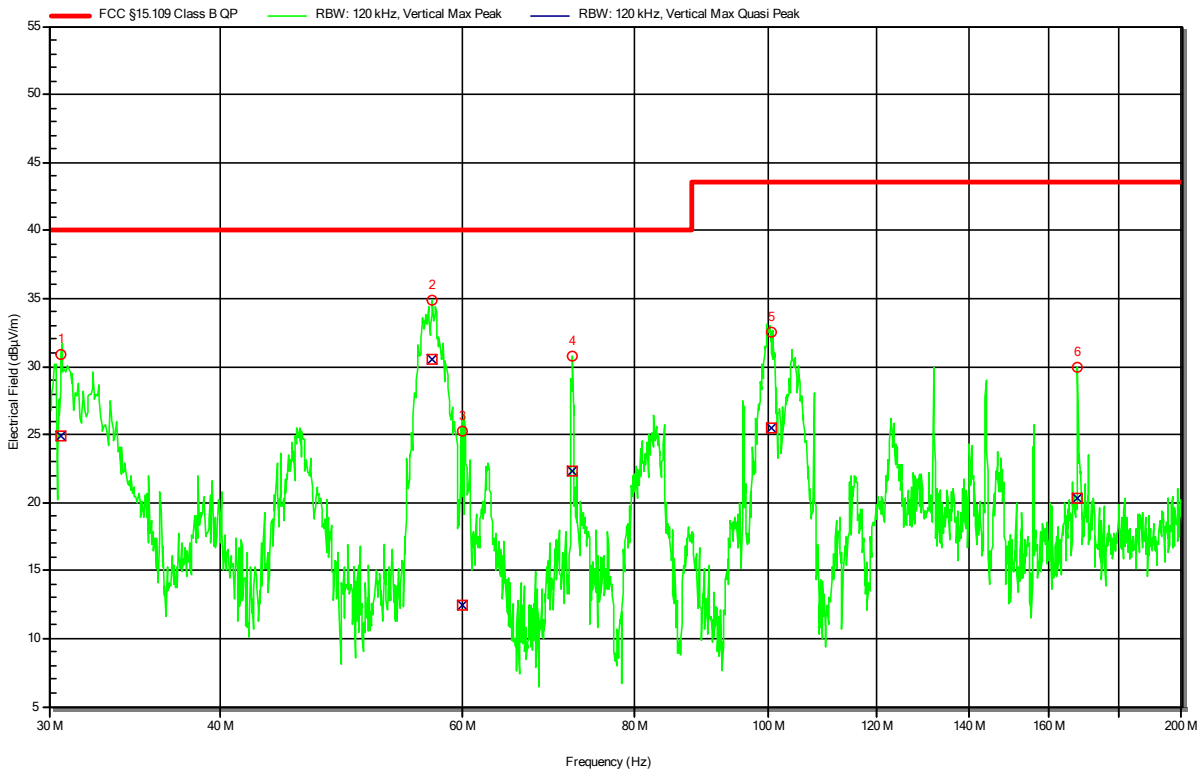

Peak Number	Frequency	Quasi-Peak	Quasi-Peak Limit	Quasi-Peak Difference	Quasi-Peak Status	Angle	Height
1	30.636 MHz	24.86 dBµV/m	40 dBµV/m	-15.14 dB	Pass	165 degrees	1 m
2	57.015 MHz	30.47 dBµV/m	40 dBµV/m	-9.53 dB	Pass	165 degrees	1 m
3	59.932 MHz	12.45 dBµV/m	40 dBµV/m	-27.55 dB	Pass	165 degrees	1 m
4	72.089 MHz	22.34 dBµV/m	40 dBµV/m	-17.66 dB	Pass	165 degrees	1 m
5	100.514 MHz	25.46 dBµV/m	43.52 dBµV/m	-18.06 dB	Pass	165 degrees	1 m
6	167.968 MHz	20.32 dBµV/m	43.52 dBµV/m	-23.2 dB	Pass	165 degrees	1 m

Radiated emissions according to FCC part 15B

Project Number: G0M-2205-1481
 Applicant: Leica Geosystems AG
 Model Description: GNSS Reference Server
 Model: GR50
 Test Sample ID: 40910
 Test Site: Eurofins Product Service GmbH
 Operator: Mr. Neuner
 Test Date: 2022-08-11
 Operating Conditions: ambient temperature: 24 °Celsius
 power input: 14.4 V DC via rechargeable lithium battery
 Antenna: Rohde & Schwarz HK 116, Horizontal
 Measurement Distance: 3m
 Operational Mode: 1
 EUT Configuration: 2
 Note 1: -

Index 42

RadiMation

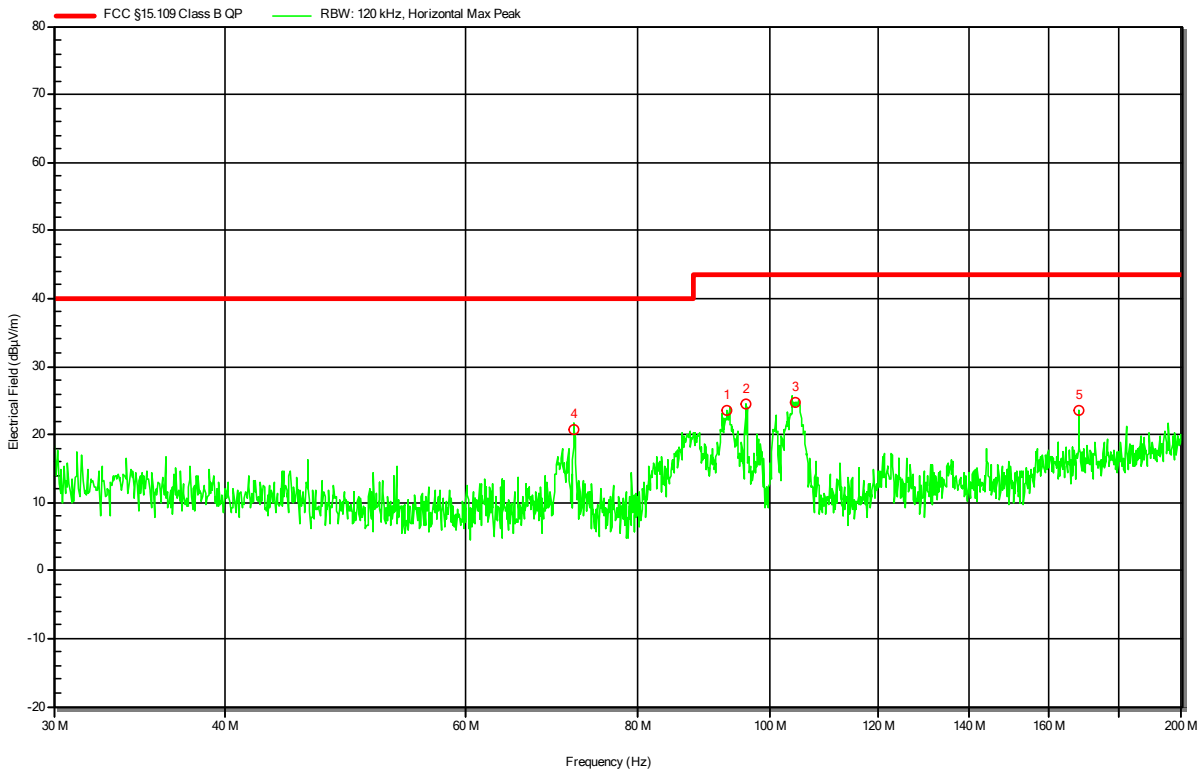

Peak Number	Frequency	Angle	Height
1	93.127 MHz	0 degrees	1 m
2	96.068 MHz	0 degrees	1 m
3	104.469 MHz	0 degrees	1 m
4	72.005 MHz	0 degrees	1 m
5	168.076 MHz	0 degrees	1 m

Radiated emissions according to FCC part 15B

Project Number: G0M-2205-1481
 Applicant: Leica Geosystems AG
 Model Description: GNSS Reference Server
 Model: GR50
 Test Sample ID: 40910
 Test Site: Eurofins Product Service GmbH
 Operator: Mr. Neuner
 Test Date: 2022-08-11
 Operating Conditions: ambient temperature: 24 °Celsius
 power input: 14.4 V DC via rechargeable lithium battery
 Antenna: Rohde & Schwarz HL 223, Vertical
 Measurement Distance: 3m
 Operational Mode: 1
 EUT Configuration: 2
 Note 1: -

Index 48

RadiMation

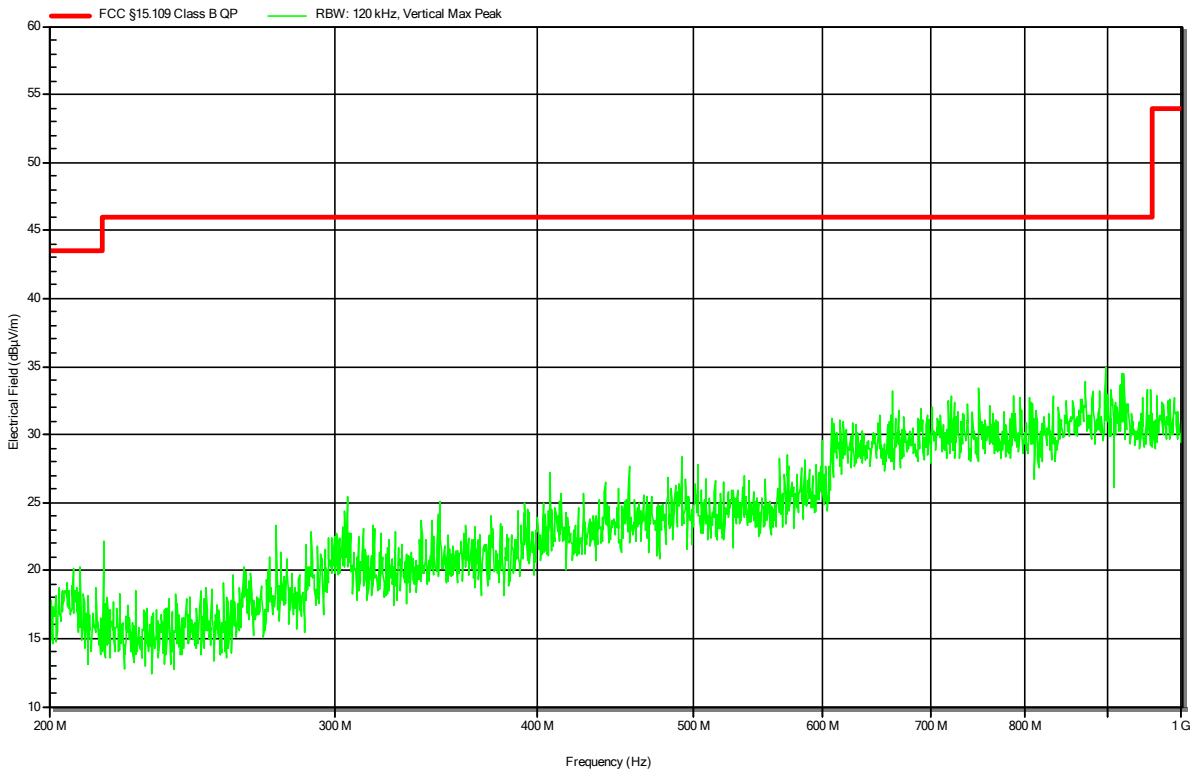

Radiated emissions according to FCC part 15B

Project Number: G0M-2205-1481
 Applicant: Leica Geosystems AG
 Model Description: GNSS Reference Server
 Model: GR50
 Test Sample ID: 40910
 Test Site: Eurofins Product Service GmbH
 Operator: Mr. Neuner
 Test Date: 2022-08-11
 Operating Conditions: ambient temperature: 24 °Celsius
 power input: 14.4 V DC via rechargeable lithium battery
 Antenna: Rohde & Schwarz HL 223, Horizontal
 Measurement Distance: 3m
 Operational Mode: 1
 EUT Configuration: 2
 Note 1: -

Index 49

RadiMation

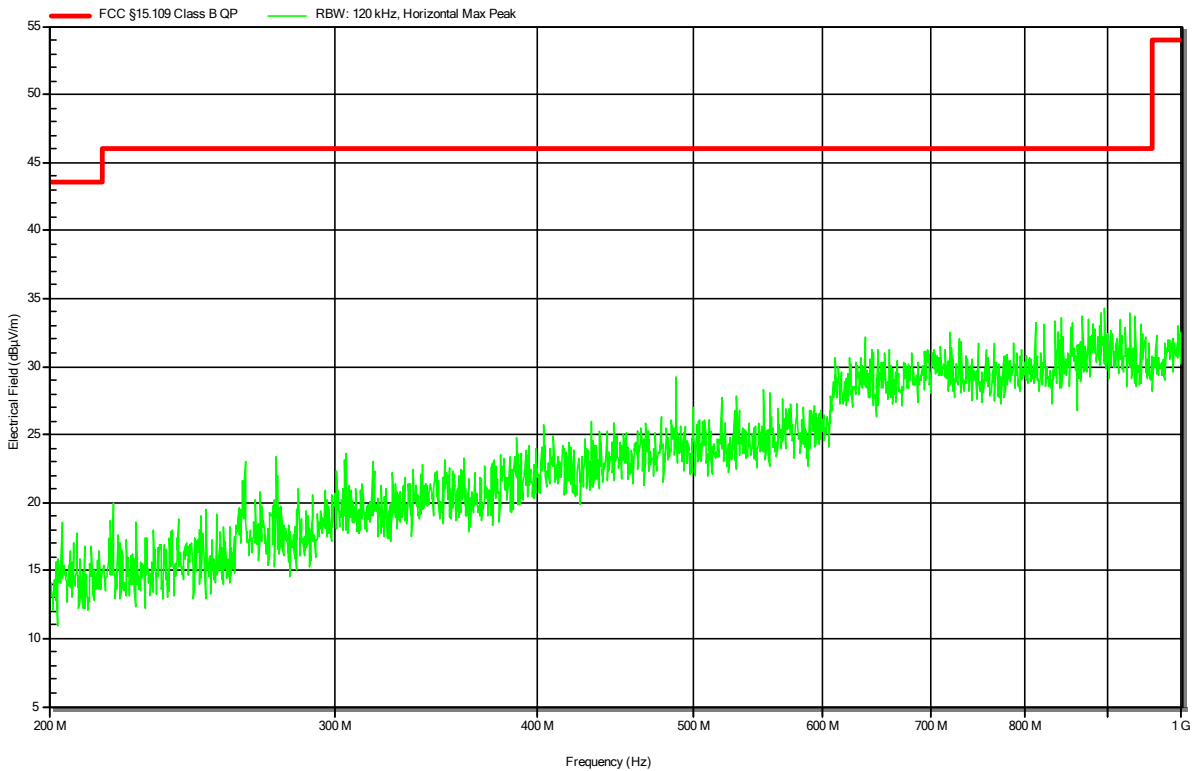

Radiated emissions according to FCC part 15B

Project Number: G0M-2205-1481
 Applicant: Leica Geosystems AG
 Model Description: GNSS Reference Server
 Model: GR50
 Test Sample ID: 40910
 Test Site: Eurofins Product Service GmbH
 Operator: Mr. Neuner
 Test Date: 2022-08-16
 Operating Conditions: ambient temperature: 23 °Celsius
 power input: 120 V AC / 60 Hz
 Antenna: Schwarzbeck BBHA 9120D, Vertical
 Measurement Distance: 3m
 Operational Mode: 1
 EUT Configuration: 1
 Note 1: -

Index 52

RadiMation

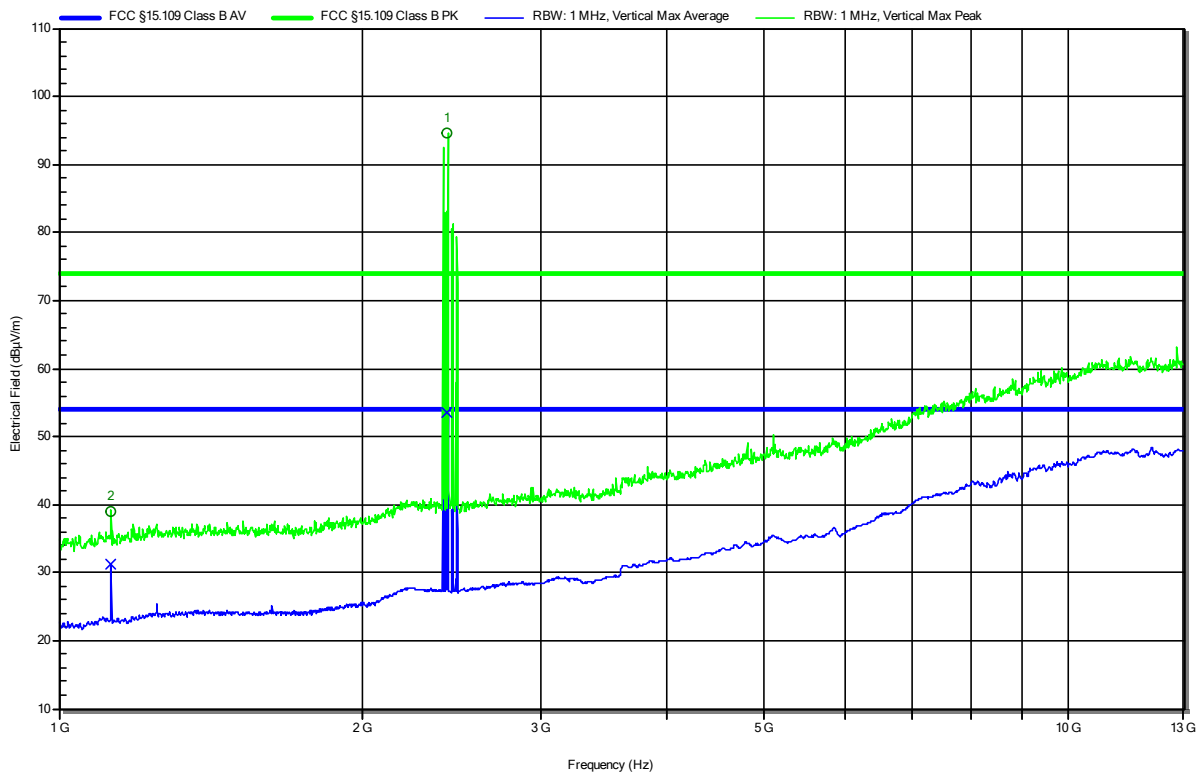

Peak Number	Frequency	Peak	Peak Limit	Peak Difference	Peak Status	Angle	Height
1	2.426 GHz	Bluetooth Carrier					
2	1.125 GHz	Bluetooth					

Peak Number	Frequency	Average	Average Limit	Average Difference	Average Status	Angle	Height
1	2.426 GHz	Bluetooth					
2	1.125 GHz	Bluetooth					

Radiated emissions according to FCC part 15B

Project Number: G0M-2205-1481
 Applicant: Leica Geosystems AG
 Model Description: GNSS Reference Server
 Model: GR50
 Test Sample ID: 40910
 Test Site: Eurofins Product Service GmbH
 Operator: Mr. Neuner
 Test Date: 2022-08-16
 Operating Conditions: ambient temperature: 24 °Celsius
 power input: 120 V AC / 60 Hz
 Antenna: Schwarzbeck BBHA 9120D, Horizontal
 Measurement Distance: 3m
 Operational Mode: 1
 EUT Configuration: 1
 Note 1: -

Index 53

RadiMation

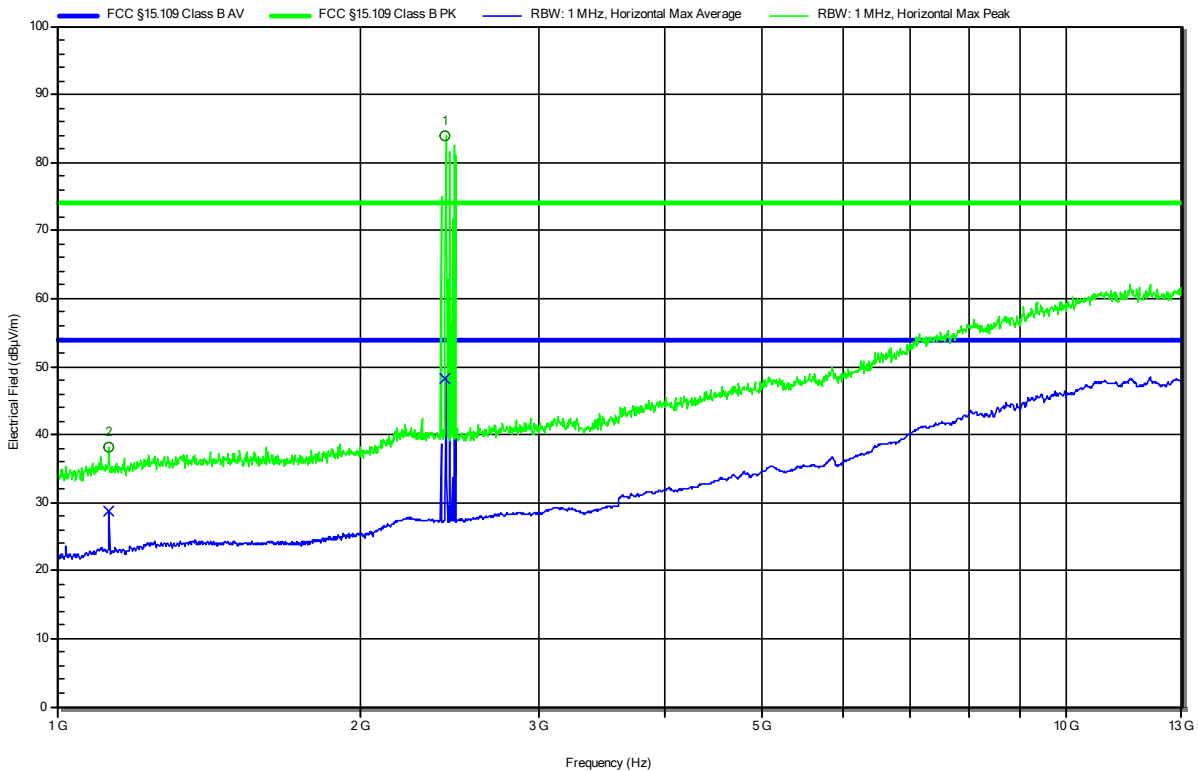

Peak Number	Frequency	Peak	Peak Limit	Peak Difference	Peak Status	Angle	Height
1	2.427 GHz	Bluetooth					
2	1.125 GHz	Bluetooth					

Peak Number	Frequency	Average	Average Limit	Average Difference	Average Status	Angle	Height
1	2.427 GHz	Bluetooth					
2	1.125 GHz	Bluetooth					

Radiated emissions according to FCC part 15B

Project Number: G0M-2205-1481
 Applicant: Leica Geosystems AG
 Model Description: GNSS Reference Server
 Model: GR50
 Test Sample ID: 40910
 Test Site: Eurofins Product Service GmbH
 Operator: Mr. Neuner
 Test Date: 2022-08-25
 Operating Conditions: ambient temperature: 23 °Celsius
 power input: 48 V DC via Power over LAN (PoE)
 Antenna: Schwarzbeck BBHA 9120D, Vertical
 Measurement Distance: 3m
 Operational Mode: 1
 EUT Configuration: 3
 Note 1: -

Index 55

RadiMation

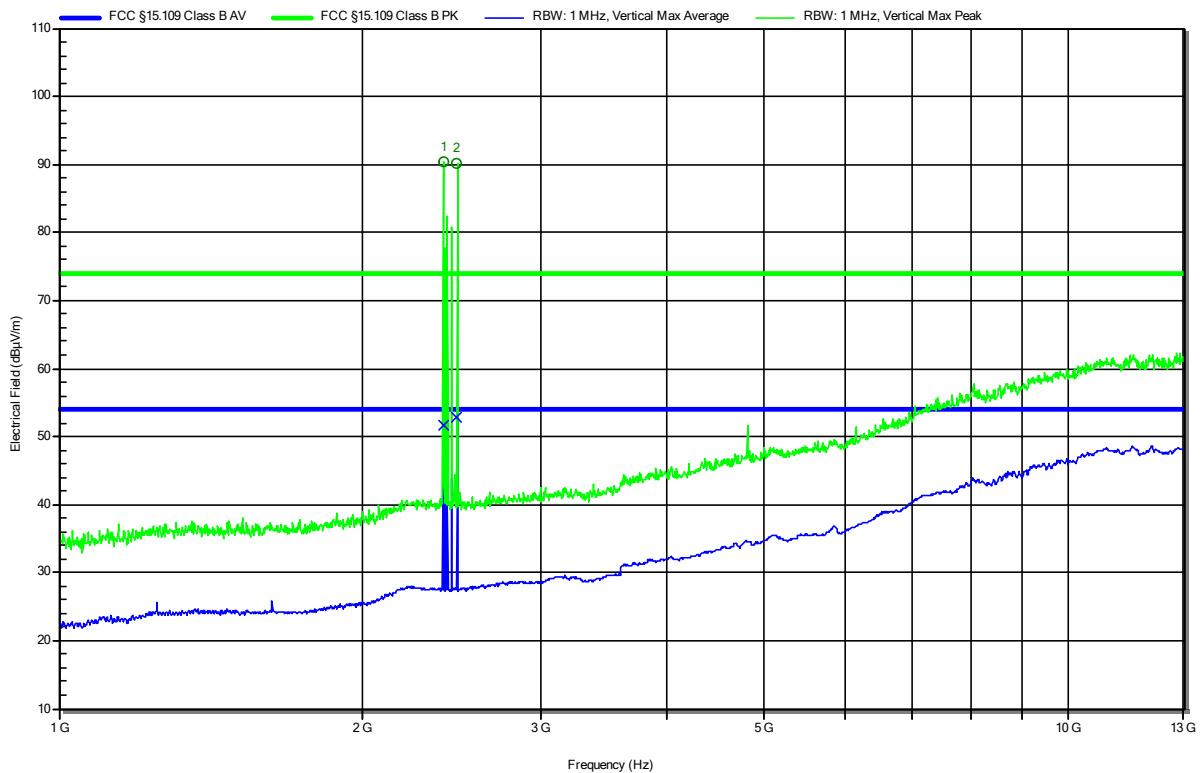

Peak Number	Frequency	Peak	Peak Limit	Peak Difference	Peak Status	Angle	Height
1	2.402 GHz	Bluetooth					
2	2.48 GHz	Bluetooth					

Peak Number	Frequency	Average	Average Limit	Average Difference	Average Status	Angle	Height
1	2.402 GHz	Bluetooth					
2	2.48 GHz	Bluetooth					

Radiated emissions according to FCC part 15B

Project Number: G0M-2205-1481
 Applicant: Leica Geosystems AG
 Model Description: GNSS Reference Server
 Model: GR50
 Test Sample ID: 40910
 Test Site: Eurofins Product Service GmbH
 Operator: Mr. Neuner
 Test Date: 2022-08-25
 Operating Conditions: ambient temperature: 23 °Celsius
 power input: 48 V DC via Power over LAN (PoE)
 Antenna: Schwarzbeck BBHA 9120D, Horizontal
 Measurement Distance: 3m
 Operational Mode: 1
 EUT Configuration: 3
 Note 1: -

Index 54

RadiMation

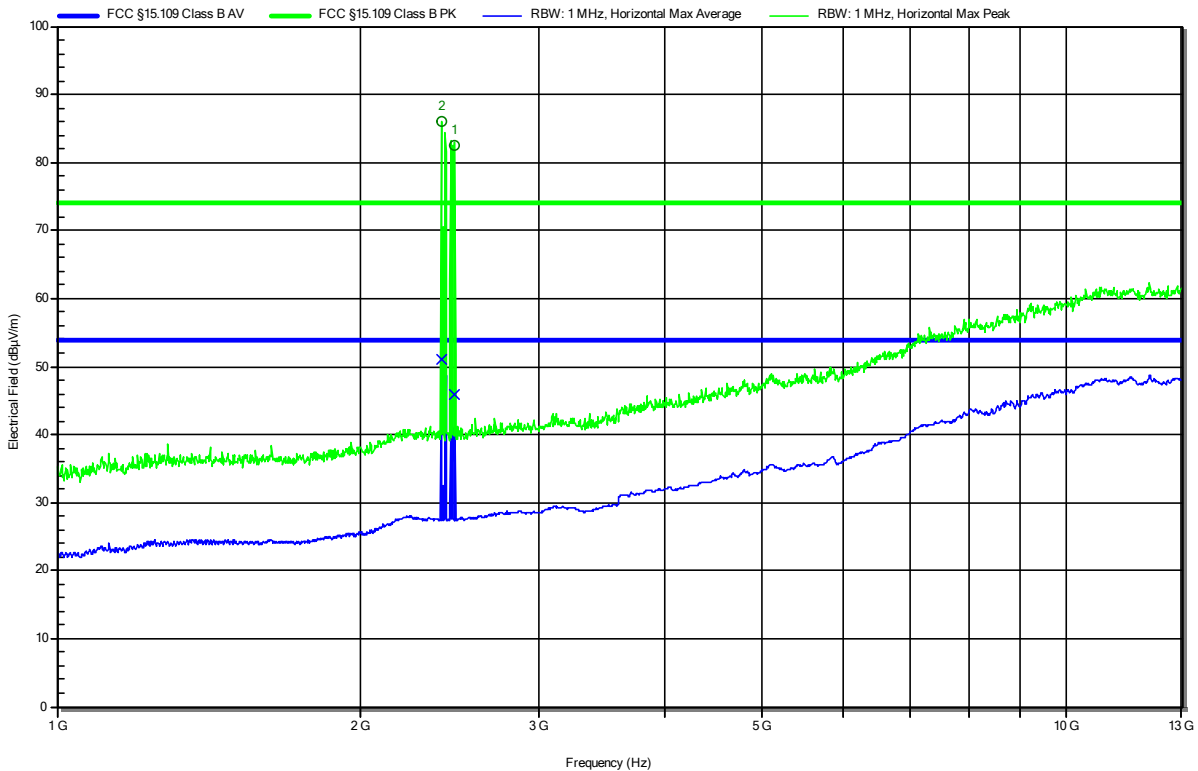

Peak Number	Frequency	Peak	Peak Limit	Peak Difference	Peak Status	Angle	Height
1	2.477 GHz	Bluetooth					
2	2.402 GHz	Bluetooth					

Peak Number	Frequency	Average	Average Limit	Average Difference	Average Status	Angle	Height
1	2.477 GHz	Bluetooth					
2	2.402 GHz	Bluetooth					

Radiated emissions according to FCC part 15B

Project Number: G0M-2205-1481
 Applicant: Leica Geosystems AG
 Model Description: GNSS Reference Server
 Model: GR50
 Test Sample ID: 40910
 Test Site: Eurofins Product Service GmbH
 Operator: Mr. Neuner
 Test Date: 2022-08-25
 Operating Conditions: ambient temperature: 23 °Celsius
 power input: 14.4 V DC via rechargeable lithium battery
 Antenna: Schwarzbeck BBHA 9120D, Vertical
 Measurement Distance: 3m
 Operational Mode: 1
 EUT Configuration: 2
 Note 1: -

Index 56

RadiMation

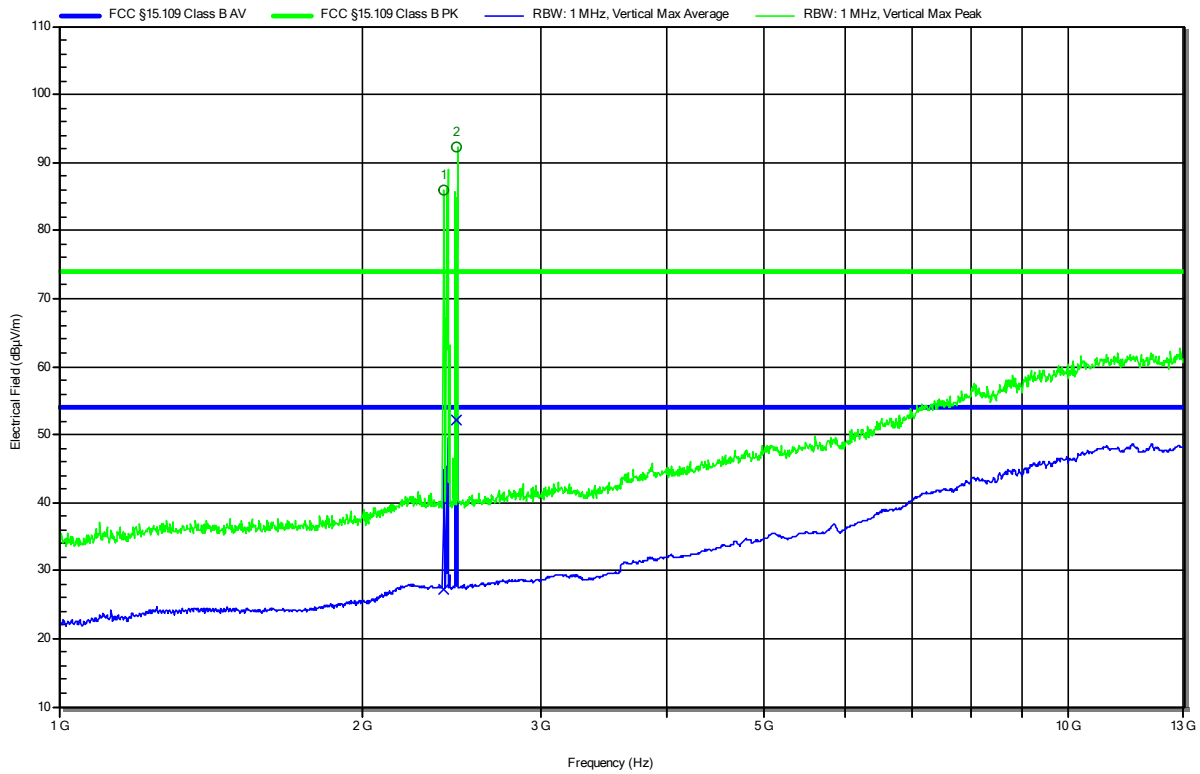

Peak Number	Frequency	Peak	Peak Limit	Peak Difference	Peak Status	Angle	Height
1	2.405 GHz	Bluetooth					
2	2.48 GHz	Bluetooth					

Peak Number	Frequency	Average	Average Limit	Average Difference	Average Status	Angle	Height
1	2.405 GHz	Bluetooth					
2	2.48 GHz	Bluetooth					

Radiated emissions according to FCC part 15B

Project Number: G0M-2205-1481
 Applicant: Leica Geosystems AG
 Model Description: GNSS Reference Server
 Model: GR50
 Test Sample ID: 40910
 Test Site: Eurofins Product Service GmbH
 Operator: Mr. Neuner
 Test Date: 2022-08-25
 Operating Conditions: ambient temperature: 23 °Celsius
 power input: 14.4 V DC via rechargeable lithium battery
 Antenna: Schwarzbeck BBHA 9120D, Horizontal
 Measurement Distance: 3m
 Operational Mode: 1
 EUT Configuration: 2
 Note 1: -

Index 57

RadiMation

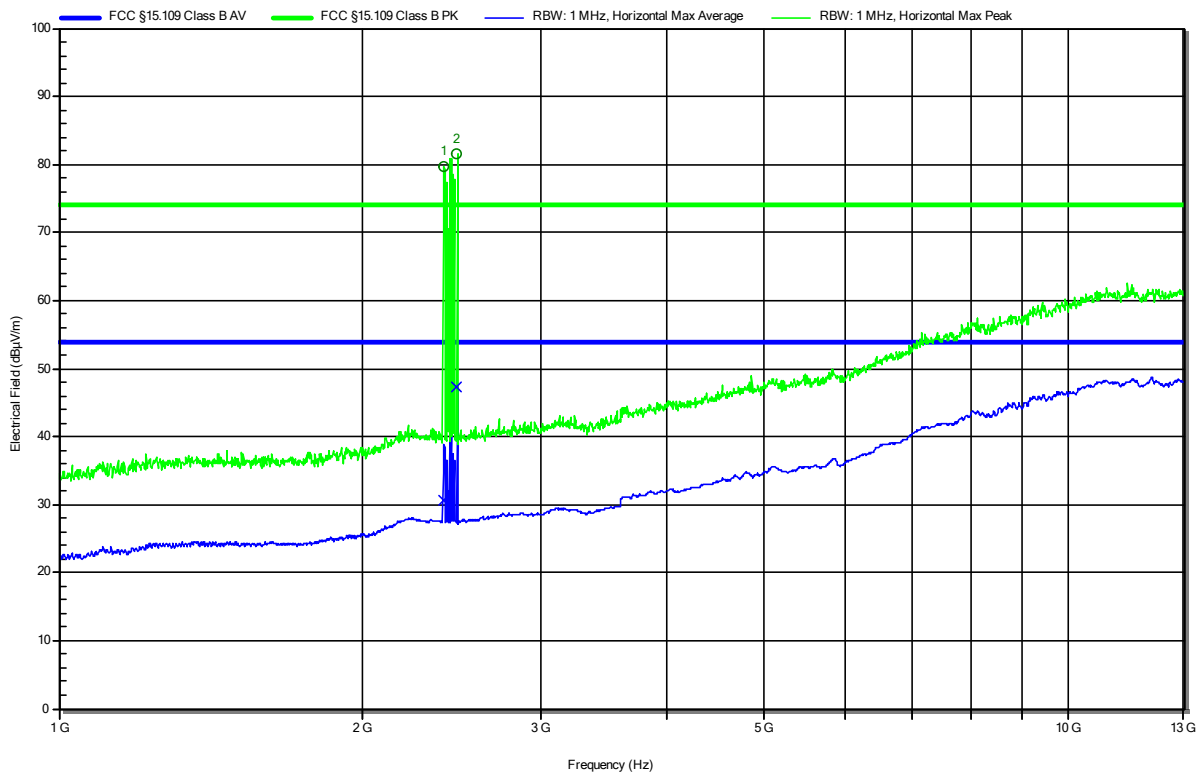

Peak Number	Frequency	Peak	Peak Limit	Peak Difference	Peak Status	Angle	Height
1	2.404 GHz	Bluetooth					
2	2.48 GHz	Bluetooth					

Peak Number	Frequency	Average	Average Limit	Average Difference	Average Status	Angle	Height
1	2.404 GHz	Bluetooth					
2	2.48 GHz	Bluetooth					

2.2 Test Conditions and Results - Conducted emissions acc. to ANSI C63.4

2.2.1 Information

Test Information	
Reference	FCC 15.107, ICES-003, 3.2.1
Reference method	ANSI C63.4:2014+A1:2017 Section 12
Measurement range	150 kHz to 30 MHz
Equipment class	Class B
Equipment type	Table top
Temperature [°C]	23 ±5
Humidity [%]	59 ±15
Operator	Marko Neuner
Date	2022-08-25

2.2.2 Setup

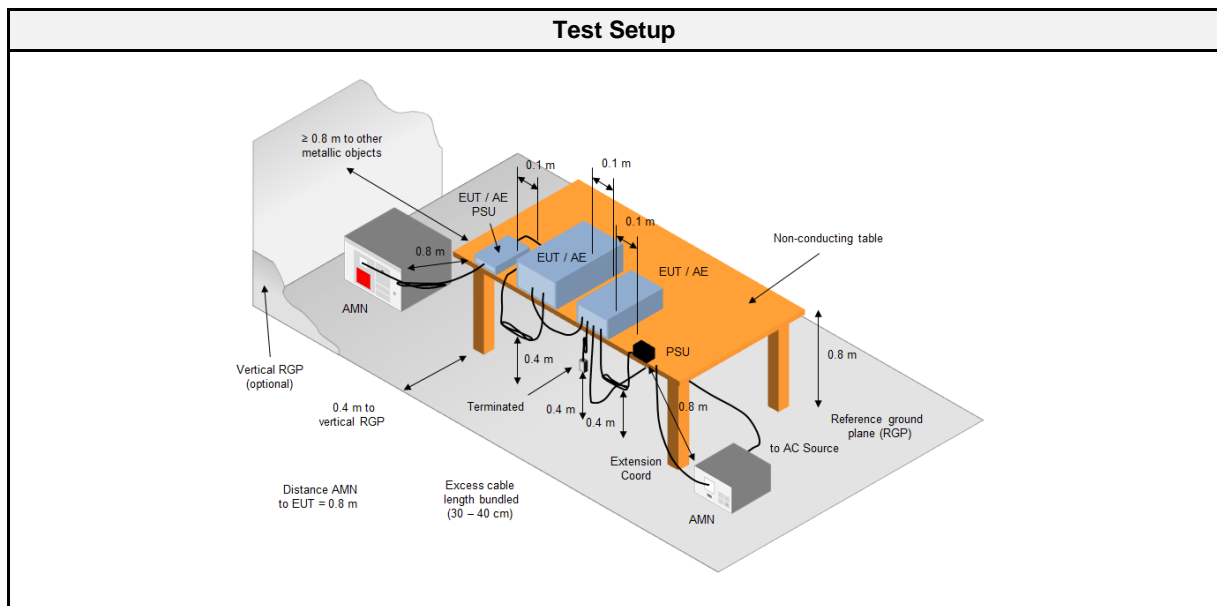
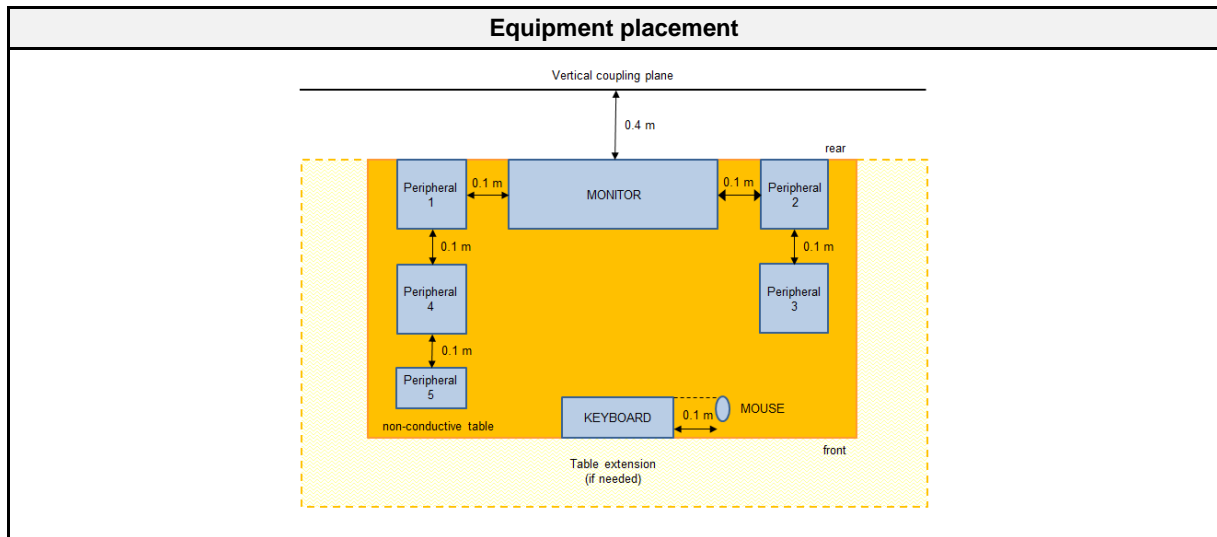

2.2.3 Equipment

Test Software			
Description	Manufacturer	Name	Version
EMC Software	DARE Instruments	Radimation	2020.1.8

Test Equipment					
Description	Manufacturer	Model	Identifier	Cal. Date	Cal. Due
AMN	Schwarzbeck	NSLK 8127	EF01592	2021-07	2023-07
AMN	R&S	ESH3-Z5	EF00036	2021-08	2023-08
Pulse Limiter	R&S	ESH3-Z2	EF01222	2021-07	2023-07
EMI Test Receiver	R&S	ESR 7	EF00943	2022-08	2023-08
Climatic Sensor	Embedded Data Systems, LLC.	2800100000254 17E	EF01054	2022-04	2023-04

2.2.4 Procedure

Exploratory measurement
<ol style="list-style-type: none"> The EUT was placed on a non conductive table 0.8 m above the reference ground plane and 0.4 m away from the vertical conducting plane (ANSI C63.4: 2014 item 7.3.1) The power cord that is normally supplied or recommended by the manufacturer was connected to the LISN. The distance between the outer edge of the EUT and the LISN shall be set to 0.8 m. A longer power cord shall be bundled to this length (bundling shall not exceed 40 cm in length). The LISN measurement port was connected to a measurement receiver I/O cables were bundled not longer than 0.4 m Measurement was performed in the frequency range 0.15 – 30MHz on each current-carrying conductor To maximize the emissions the cable positions were manipulated The worst configuration of EUT and cables is shown on a test setup picture at item 2.2.2

Final measurement
<ol style="list-style-type: none"> The EUT was placed on a non conductive table 0.8 m above the reference ground plane and 0.4 m away from the vertical conducting plane (ANSI C63.4: 2014 item 7.3.1) The power cord that is normally supplied or recommended by the manufacturer was connected to the LISN. The distance between the outer edge of the EUT and the LISN shall be set to 0.8 m. A longer power cord shall be bundled to this length (bundling shall not exceed 40 cm in length). The LISN measurement port was connected to a measurement receiver The EUT and cable arrangement were based on the exploratory measurement results The test data of the worst-case conditions were recorded and shown on the next pages

2.2.5 Limits

Class B		
Frequency [MHz]	Quasi-peak Limit [dBµV]	Average Limit [dBµV]
0.15 - 0.5	66 - 56 *	56 - 46 *
0.5 - 5	56	46
5 - 30	60	50

* Decreases with the logarithm of the frequency

2.2.6 Results

AC power line conducted emissions					
Port	Coupling	Operational mode	EUT Configuration	Verdict	Remark
Power	AMN	1	1	PASS	120 V AC / 60 Hz
Power	AMN	1	3	PASS	PoE-Injector; 120 V AC / 60 Hz

2.2.7 Setup Photos

Test Setup AC/DC Adapter



Test Setup PoE Adapter

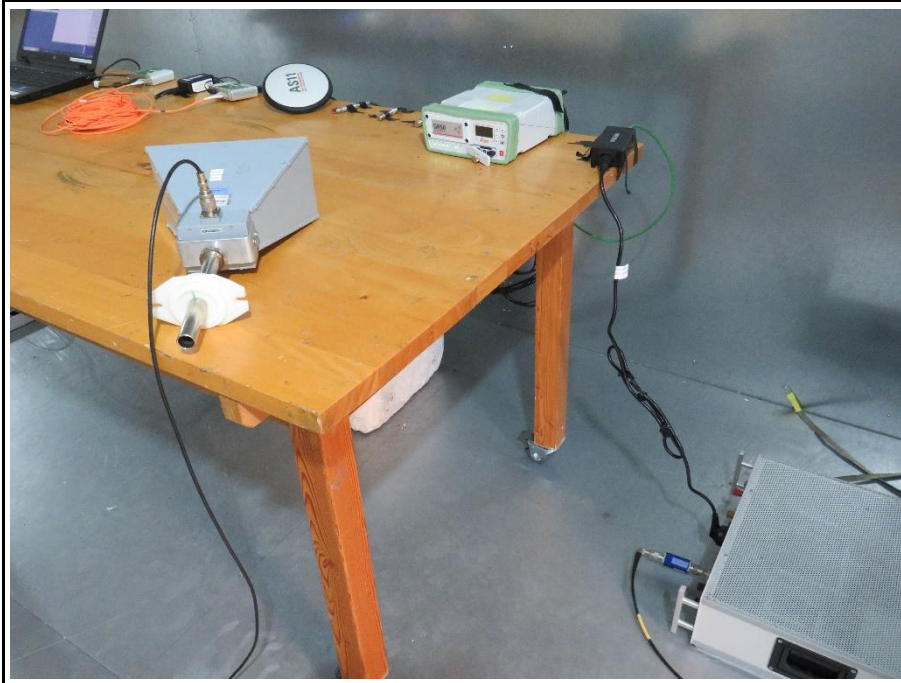

2.2.8 Records

Conducted emissions at the mains power port according to FCC part 15B

Project Number: G0M-2205-1481
 Applicant: Leica Geosystems AG
 Model Description: GNSS Reference Server
 Model: GR50
 Test Sample ID: 40910
 Test Site: Eurofins Product Service GmbH
 Operator: Mr. Liebich
 Test Date: 2022-08-25
 Operating Conditions: ambient temperature: 23 °Celsius
 power input: 120 V AC / 60 Hz
 LISN: Schwarzbeck NSLK 8127 RC L1
 Operational Mode: 1
 EUT Configuration: 1
 Applied to Port: Power port
 Note 1: -

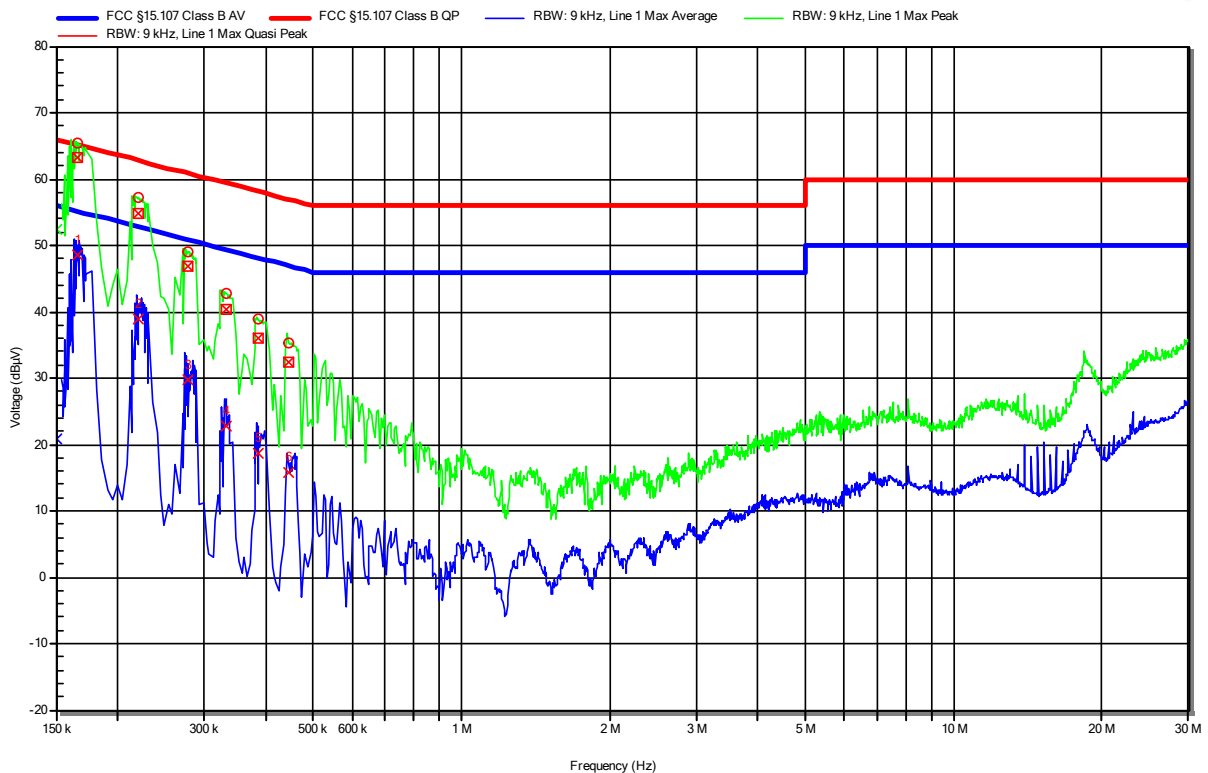

Peak Number	Frequency (MHz)	Quasi-Peak (dBµV)	Limit (dBµV)	Quasi-Peak Difference (dB)	Quasi-Peak Status	LISN
1	0.166	63.28	65.17	-1.89	Pass	Line 1
2	0.221	54.7	62.79	-8.09	Pass	Line 1
3	0.277	46.85	60.89	-14.04	Pass	Line 1
4	0.334	40.31	59.36	-19.05	Pass	Line 1
5	0.386	35.92	58.14	-22.22	Pass	Line 1
6	0.447	32.31	56.93	-24.62	Pass	Line 1

Peak Number	Frequency (MHz)	Average (dB μ V)	Average (dB μ V)	Limit	Average Difference (dB)	Average Status	LISN
1	0.166	48.57	55.17		-6.6	Pass	Line 1
2	0.221	38.97	52.79		-13.82	Pass	Line 1
3	0.277	29.74	50.89		-21.15	Pass	Line 1
4	0.334	22.88	49.36		-26.48	Pass	Line 1
5	0.386	18.61	48.14		-29.54	Pass	Line 1
6	0.447	15.79	46.93		-31.14	Pass	Line 1

Conducted emissions at the mains power port according to FCC part 15B

Project Number: G0M-2205-1481
 Applicant: Leica Geosystems AG
 Model Description: GNSS Reference Server
 Model: GR50
 Test Sample ID: 40910
 Test Site: Eurofins Product Service GmbH
 Operator: Mr. Liebich
 Test Date: 2022-08-25
 Operating Conditions: ambient temperature: 23 °Celsius
 power input: 120 V AC / 60 Hz
 LISN: Schwarzbeck NSLK 8127 RC N
 Operational Mode: 1
 EUT Configuration: 1
 Applied to Port: Power port
 Note 1: -

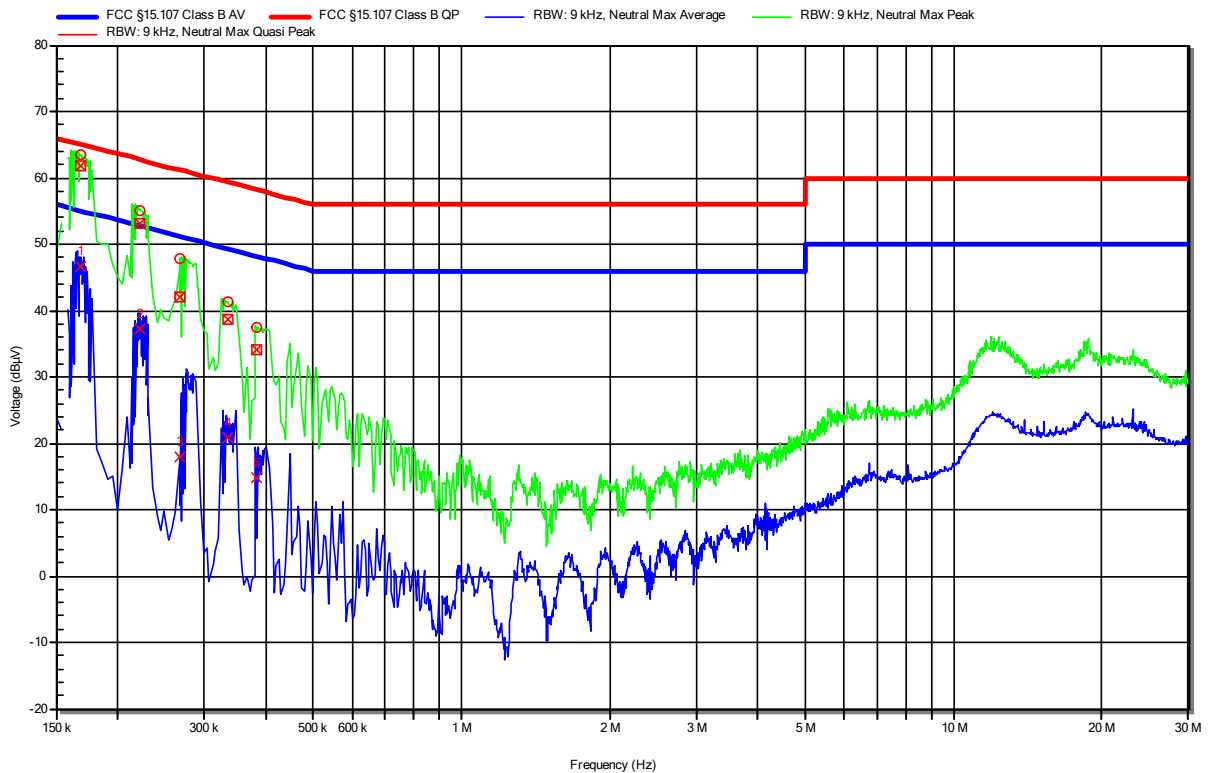

Peak Number	Frequency (MHz)	Quasi-Peak (dBµV)	Quasi-Peak Limit (dBµV)	Quasi-Peak Difference (dB)	Quasi-Peak Status	LISN
1	0.168	61.74	65.04	-3.3	Pass	Neutral
2	0.223	53.07	62.71	-9.64	Pass	Neutral
3	0.267	42.06	61.2	-19.14	Pass	Neutral
4	0.334	38.72	59.34	-20.62	Pass	Neutral
5	0.384	34.19	58.2	-24.01	Pass	Neutral

Peak Number	Frequency (MHz)	Average (dB μ V)	Average (dB μ V)	Limit	Average Difference (dB)	Average Status	LISN
1	0.168	46.66	55.04		-8.37	Pass	Neutral
2	0.223	37.12	52.71		-15.59	Pass	Neutral
3	0.267	17.99	51.2		-33.21	Pass	Neutral
4	0.334	20.85	49.34		-28.48	Pass	Neutral
5	0.384	14.71	48.2		-33.49	Pass	Neutral

Conducted emissions at the mains power port according to FCC part 15B

Project Number: G0M-2205-1481
 Applicant: Leica Geosystems AG
 Model Description: GNSS Reference Server
 Model: GR50
 Test Sample ID: 40910
 Test Site: Eurofins Product Service GmbH
 Operator: Mr. Neuner
 Test Date: 2022-08-25
 Operating Conditions: ambient temperature: 23 °Celsius
 power input: 48 V DC via Power over LAN (PoE)
 LISN: Schwarzbeck NSLK 8127 RC L1
 Operational Mode: 1
 EUT Configuration: 3
 Applied to Port: Power port
 Note 1: PoE device PowerDsine3001GB

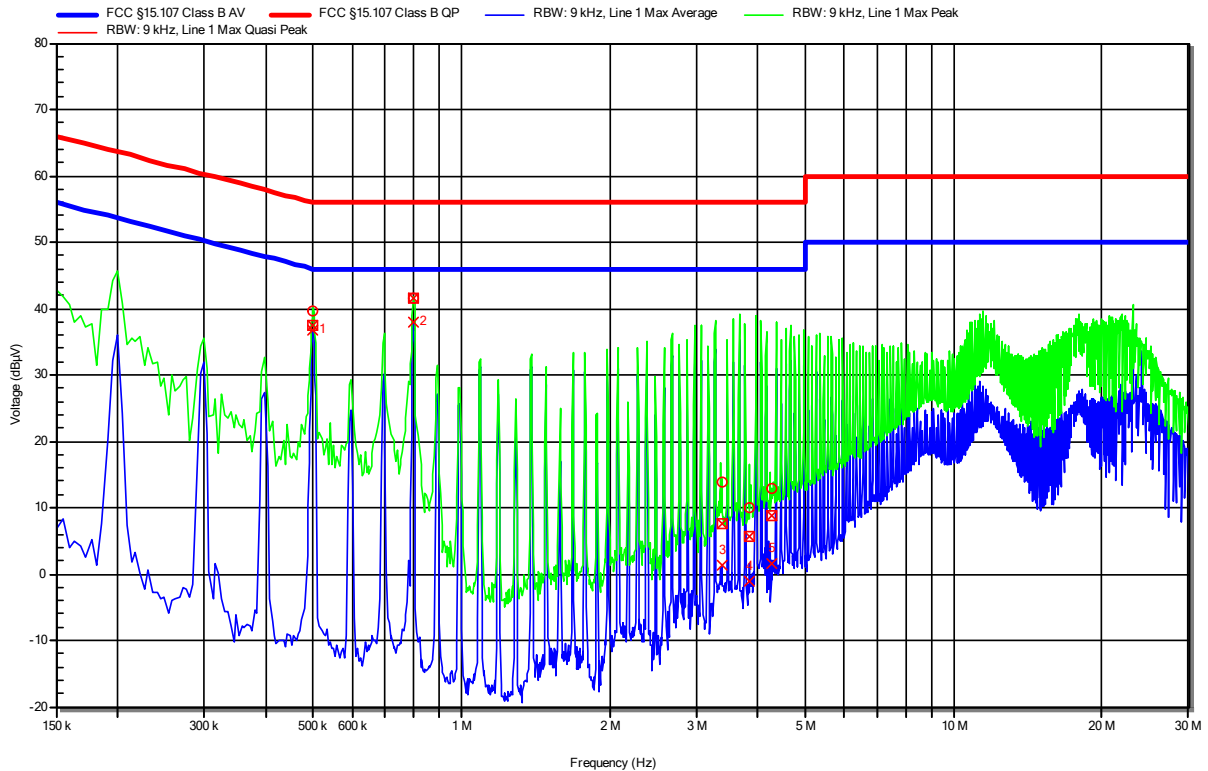

Peak Number	Frequency (MHz)	Quasi-Peak (dBµV)	Quasi-Peak Limit (dBµV)	Quasi-Peak Difference (dB)	Quasi-Peak Status	LISN
1	0.499	37.51	56.02	-18.51	Pass	Line 1
2	0.798	41.64	56	-14.36	Pass	Line 1
3	3.377	7.52	56	-48.48	Pass	Line 1
4	3.854	5.69	56	-50.31	Pass	Line 1
5	4.265	8.78	56	-47.22	Pass	Line 1

Peak Number	Frequency (MHz)	Average (dB μ V)	Average (dB μ V)	Limit	Average Difference (dB)	Average Status	LISN
1	0.499	36.64	46.02		-9.38	Pass	Line 1
2	0.798	37.98	46		-8.02	Pass	Line 1
3	3.377	1.32	46		-44.68	Pass	Line 1
4	3.854	-1.16	46		-47.16	Pass	Line 1
5	4.265	1.59	46		-44.41	Pass	Line 1

Conducted emissions at the mains power port according to FCC part 15B

Project Number: G0M-2205-1481
 Applicant: Leica Geosystems AG
 Model Description: GNSS Reference Server
 Model: GR50
 Test Sample ID: 40912
 Test Site: Eurofins Product Service GmbH
 Operator: Mr. Neuner
 Test Date: 2022-08-25
 Operating Conditions: ambient temperature: 23 °Celsius
 power input: 48 V DC via Power over LAN (PoE)
 LISN: Schwarzbeck NSLK 8127 RC N
 Operational Mode: 1
 EUT Configuration: 3
 Applied to Port: Power port
 Note 1: PoE device PowerDsine3001GB

Index 16
RadiMation

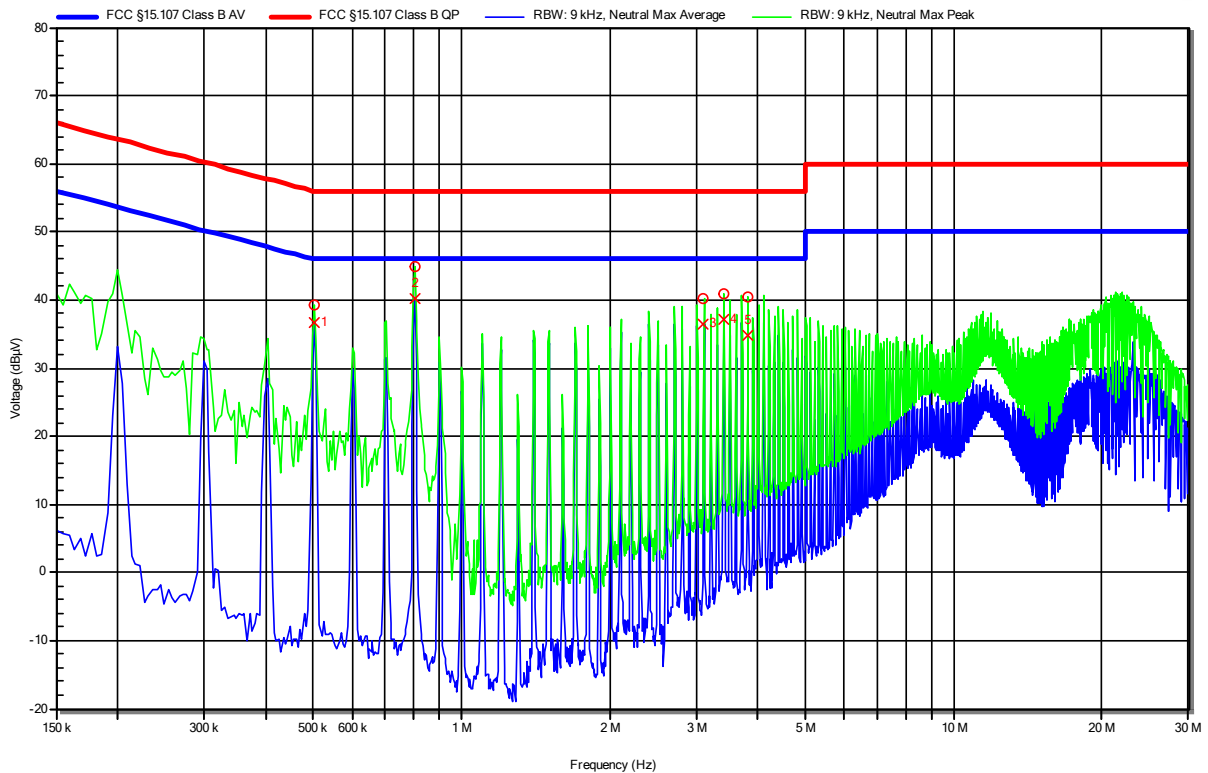

Peak Number	Frequency (MHz)	Average (dB μ V)	Average (dB μ V)	Limit	Average Difference (dB)	Average Status	LISN
1	0.501	36.63	46		-9.37	Pass	Neutral
2	0.802	40.14	46		-5.86	Pass	Neutral
3	3.107	36.48	46		-9.52	Pass	Neutral
4	3.408	37.15	46		-8.85	Pass	Neutral
5	3.809	34.75	46		-11.25	Pass	Neutral

3 Measurement Uncertainty

All test measurements carried out are traceable to national standards. The uncertainty of the measurement at a confidence level of approximately 95%, with a coverage factor of 2.

Test Name	Measurement Uncertainty
Conducted emissions at the mains power port	150kHz to 30MHz, 3.35dB
Radiated Emission	30MHz to 200MHz @ 3m, 5.1dB 200MHz to 1GHz @ 3m, 5.3dB >1GHz to 13 GHz @3m, 5.95dB