





RADIO DFS REPORT FCC 47 CFR Part 15E, ISED Canada RSS-247 Unlicensed National Information Infrastructure Devices in the 5 GHz Bands	
Report Reference No	G0M-2011-9488-TFC407DF-V01
Testing Laboratory	Eurofins Product Service GmbH
Address	Storkower Str. 38c 15526 Reichenwalde Germany
Accreditation	    DAkks - Registration number : D-PL-12092-01-03 (ISED) ISED Testing Laboratory site: 3470A DAkks - Registration number : D-PL-12092-01-04 (FCC) FCC Filed Test Laboratory, Reg.-No.: 96970
Applicant	Leica Geosystems AG
Address	Heinrich-Wild-Strasse 9435 Heerbrugg SWITZERLAND
Test Specification	47 CFR Part 15E RSS-247, Issue 2, 2017-02
Non-Standard Test Method	None
Equipment under Test (EUT):	
Product Description	UAV 3D measurement device
Model(s)	BLK2FLY
Additional Model(s)	None
Brand Name(s)	Leica Geosystems AG
Hardware Version(s)	Rev. D
Software Version(s)	0.13.0
FCC ID	RFD-BLK2FLY
IC	3177A-BLK2FLY
Test Result	PASSED

Possible test case verdicts:		
Required by standard but not tested	N/T	
Not required by standard	N/R	
Not applicable to EUT	N/A	
Test object does meet the requirement	P(PASS)	
Test object does not meet the requirement	F(FAIL)	
Testing:		
Test Lab Temperature	20 - 23 °C	
Test Lab Humidity	32 – 38 %	
Date of receipt of test item	2021-07-19	
Report:		
Compiled by	Toralf Jahn	
Tested by (+ signature) (Responsible for Test)	Toralf Jahn	
Approved by (+ signature) (Test Lab Engineer)	Wilfried Treffke	
Date of Issue	2022-01-07	
Total number of pages	37	
General Remarks:		
<p>The test results presented in this report relate only to the object tested.</p> <p>The results contained in this report reflect the results for this particular model and serial number. It is the responsibility of the manufacturer to ensure that all production models meet the intent of the requirements detailed within this report.</p> <p>This report shall not be reproduced, except in full, without the written approval of the Issuing testing laboratory.</p>		
Additional Comments:		

VERSION HISTORY

Version History			
Version	Issue Date	Remarks	Revised By
01	2022-01-07	Initial Release	

ABBREVIATIONS AND ACRONYMS

Acronyms	
Acronym	Description
BPSK	Binary Phase Shift Keying
DFS	Dynamic Frequency Selection
EIRP	Equivalent Isotropic Radiated Power
EUT	Equipment Under Test
FCC	Federal Communications Commission
HT	High Throughput
IEEE 802.11	MAC and PHY Layer for WiFi
ISED	Innovation, Science and Economic Development Canada
OFDM	Orthogonal Frequency Division Multiplexing
QAM	Quadrature Amplitude Modulation
QPSK	Quadrature Phase Shift Keying
RBW	Resolution bandwidth
RMS	Root mean square
TPC	Transmit Power Control
VBW	Video bandwidth
VHT	Very High Throughput

REPORT INDEX

1 Equipment (Test Item) Under Test..... 6

1.1 Photos – Equipment External7

1.2 Photos – Equipment Internal 10

1.3 Photos – Test Setup.....22

1.4 Support Equipment.....23

1.5 Test Modes24

1.6 Test Frequencies.....25

1.7 Normative References.....26

2 DFS Specifications 27

2.1 DFS Detection Thresholds27

2.2 DFS Requirements prior to use of channel27

2.3 DFS Requirements during normal operation27

2.4 DFS Requirements for EUTs with multiple bandwidth modes28

2.5 DFS Response Requirements.....28

2.6 DFS Short Radar Waveforms.....29

2.7 DFS Long Radar Waveform30

2.8 DFS Hopping Radar Waveform.....30

3 Result Summary..... 31

4 Test Conditions and Results..... 32

4.1 Test Conditions and Results - Channel Closing Transmission and Channel Move Time32

4.2 Test Conditions and Results - Non-Occupancy Time.....35

1 Equipment (Test Item) Under Test

Description	UAV 3D measurement device	
Model	BLK2FLY	
Additional Model(s)	None	
Brand Name(s)	Leica Geosystems AG	
Serial Number(s)	Conducted: None (Sample ID 34982)	
Hardware Version(s)	Rev. D	
Software Version(s)	0.13.0	
Equipment type	End Product	
DFS Roles	Client without radar detection	
Radio type	Transceiver	
Assigned frequency bands	5150 - 5250 MHz 5250 - 5350 MHz 5470 - 5725 MHz	
Radio technology	IEEE 802.11a IEEE 802.11n (HT20) IEEE 802.11n (HT40) IEEE 802.11ac (VHT20) IEEE 802.11ac (VHT40) IEEE 802.11ac (VHT80)	
Modulation	BPSK, QPSK, 16-QAM, 64-QAM, 256-QAM	
Number of antenna ports	2	
Antenna 1	Type	External
	Model	SZ1784V
	Manufacturer	Pulse
	Gain	2.2 dBi (manufacturer declaration)
Antenna 1	Type	External
	Model	SZ1679W
	Manufacturer	Pulse
	Gain	4.8 dBi (manufacturer declaration)
Supply Voltage	V _{NOM}	14.8 VDC
Operating Temperature	T _{NOM}	25 °C
Battery supply	Yes	
AC/DC-Adaptor	None	
Manufacturer	Leica Geosystems AG Heinrich-Wild-Strasse 9435 Heerbrugg SWITZERLAND	

1.1 Photos – Equipment External

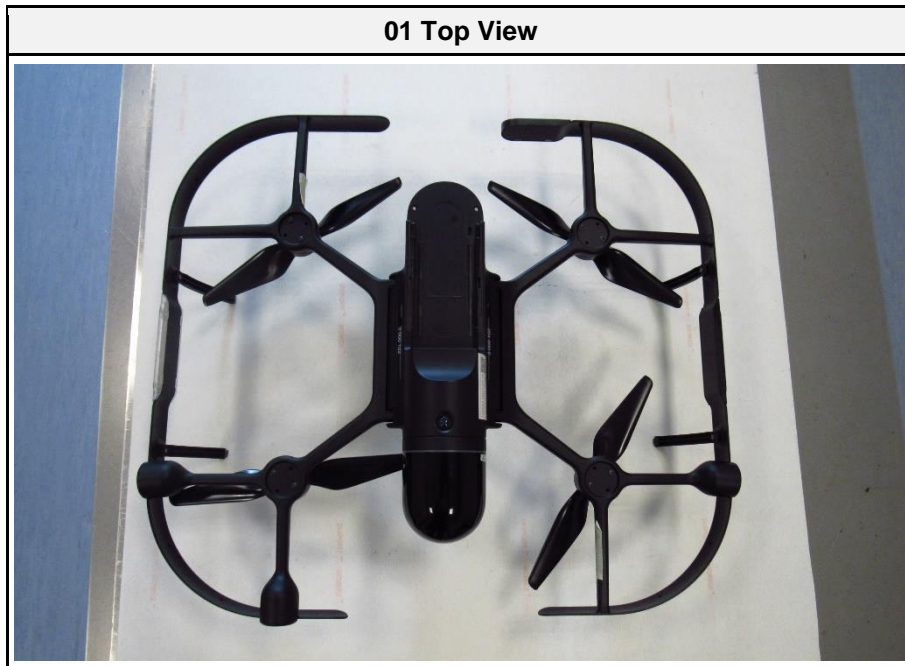

03 Front View

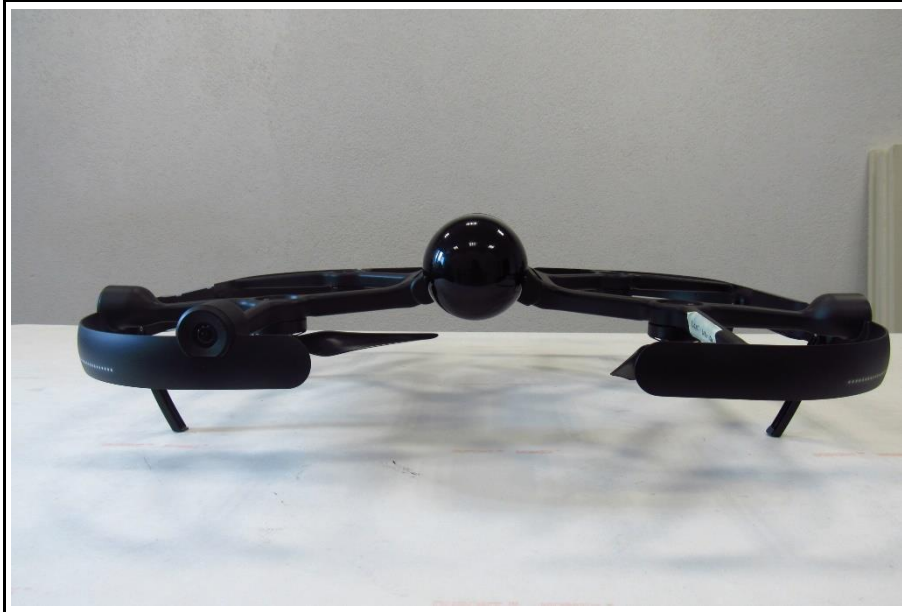

04 Rear View

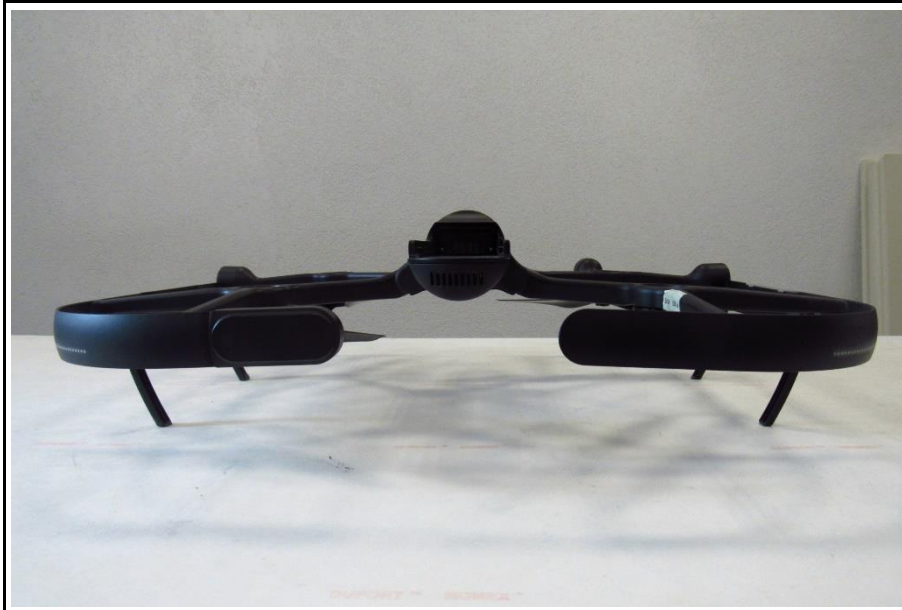

05 Right View



06 Left View

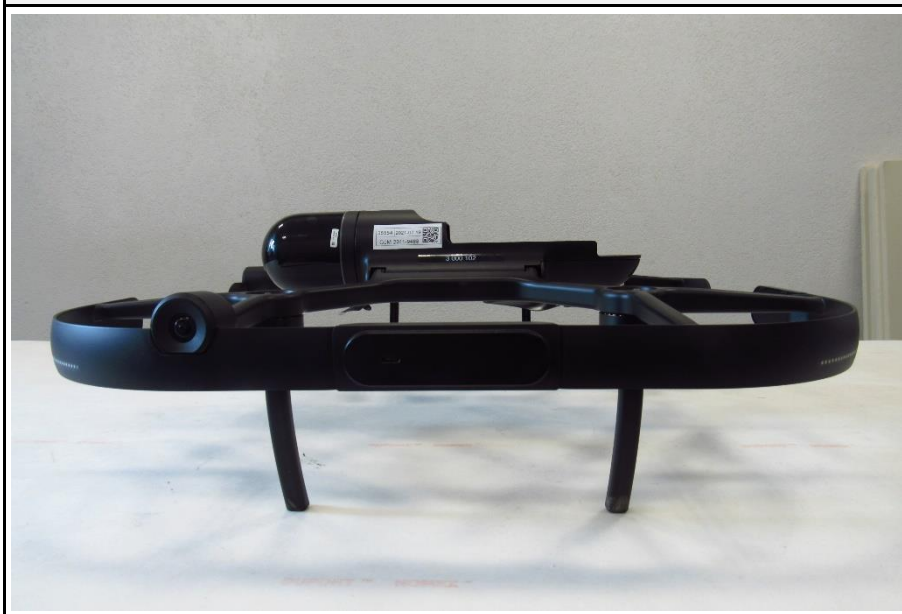

1.2 Photos – Equipment Internal

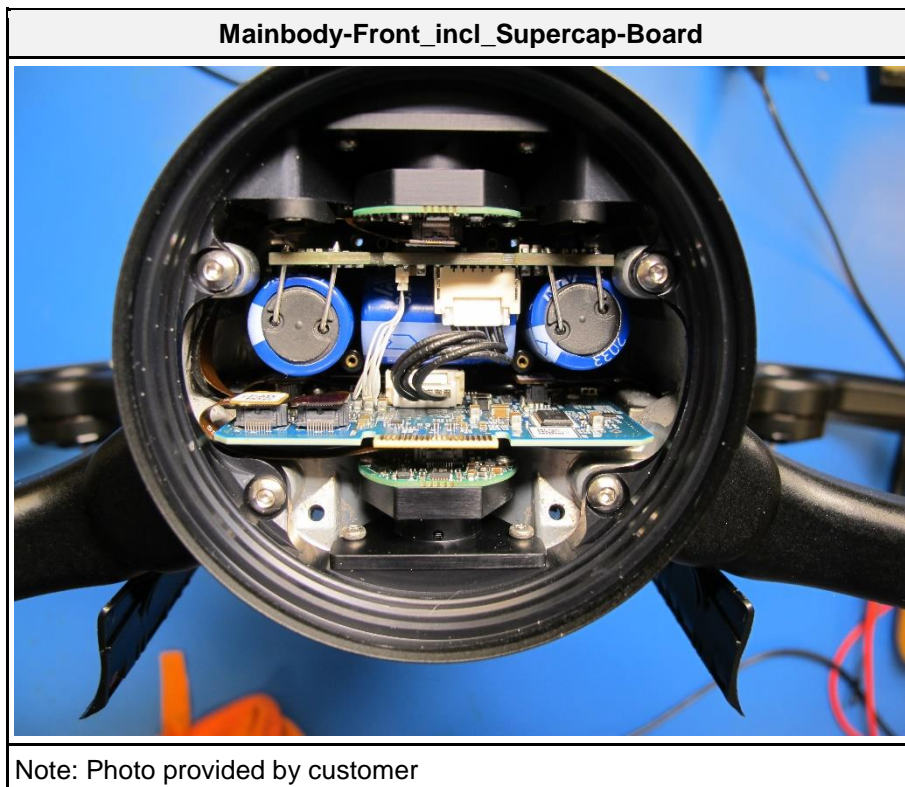
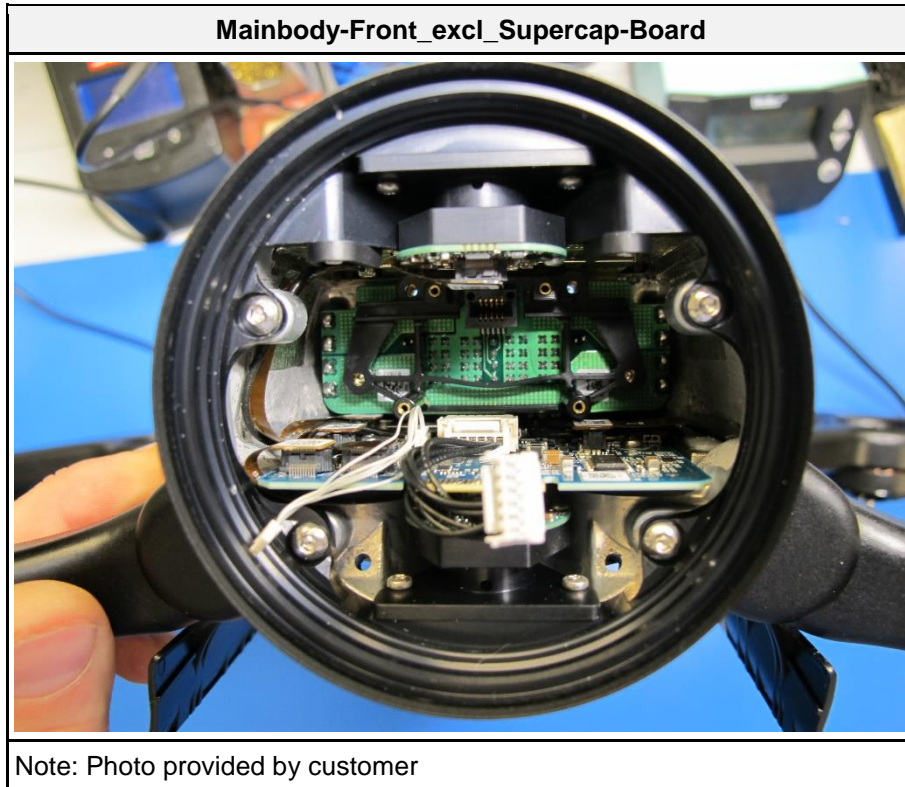

07 Conducted WLAN Sample1

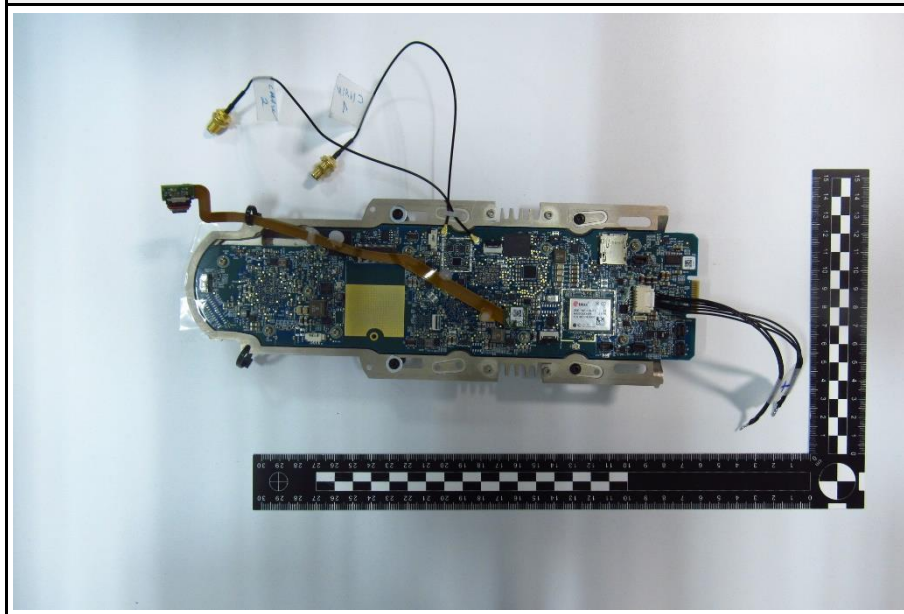

08 Conducted WLAN Sample2

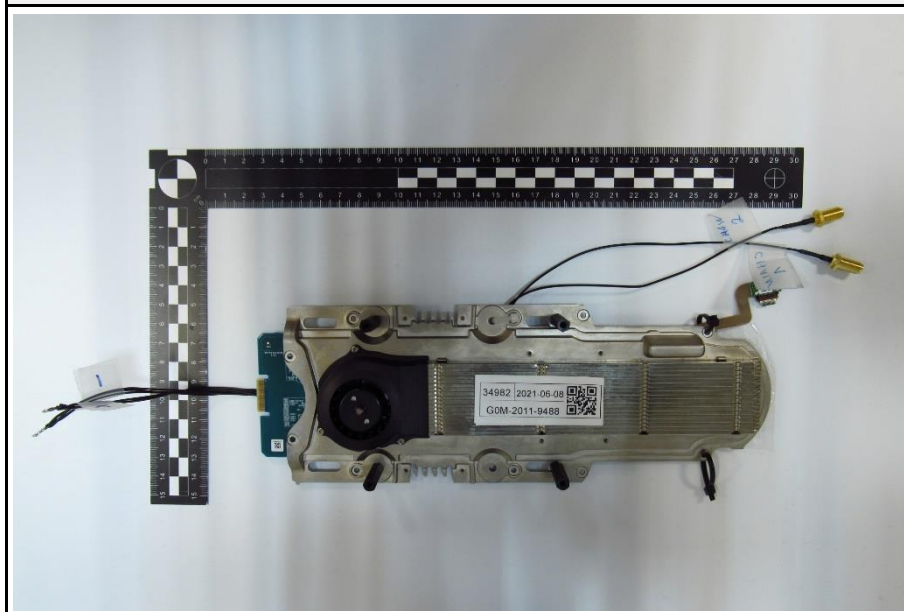

890108_LTE-Main_OVERVIEW

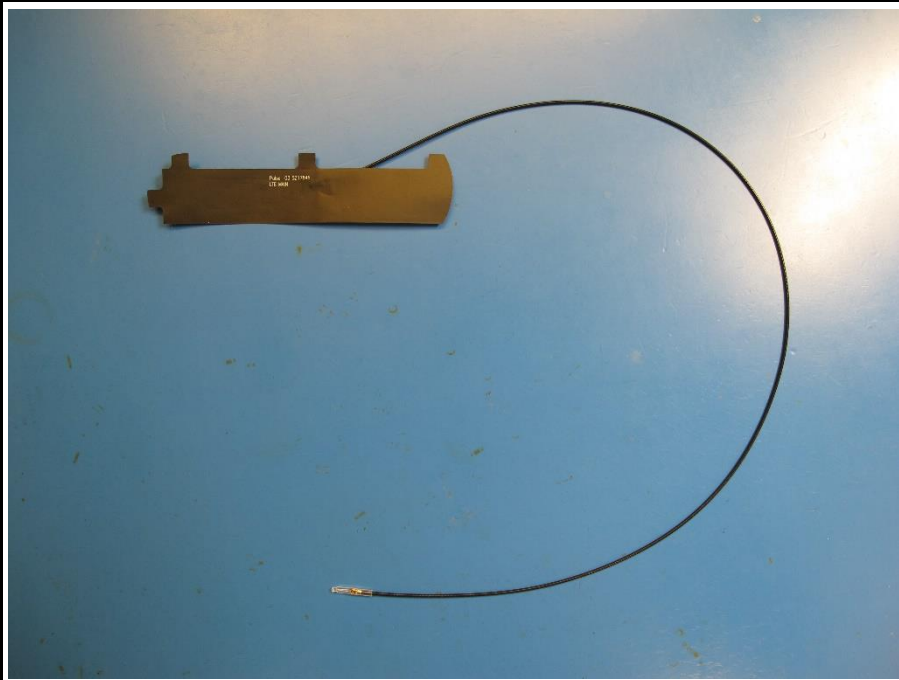

Note: Photo provided by customer

891349_LTE-Div_OVERVIEW

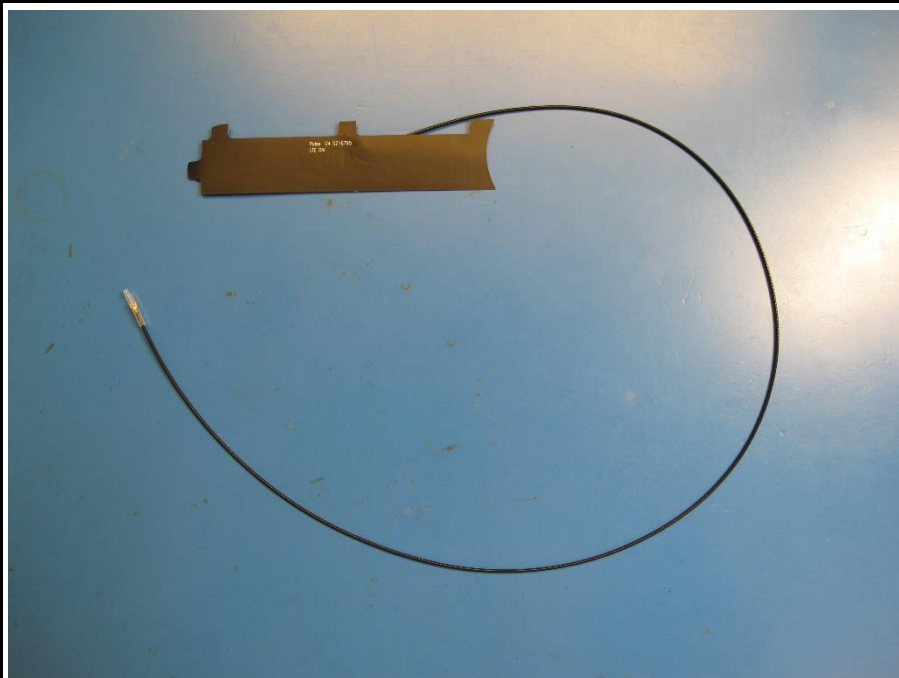

Note: Photo provided by customer

896802_Wifi-Left_OVERVIEW

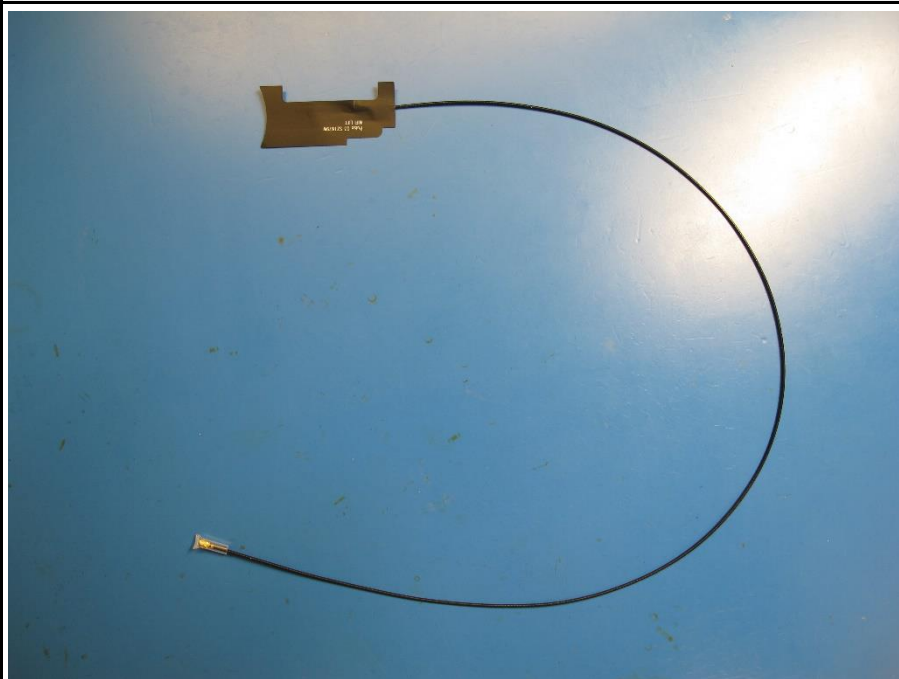

Note: Photo provided by customer

896802_Wifi-Right_OVERVIEW

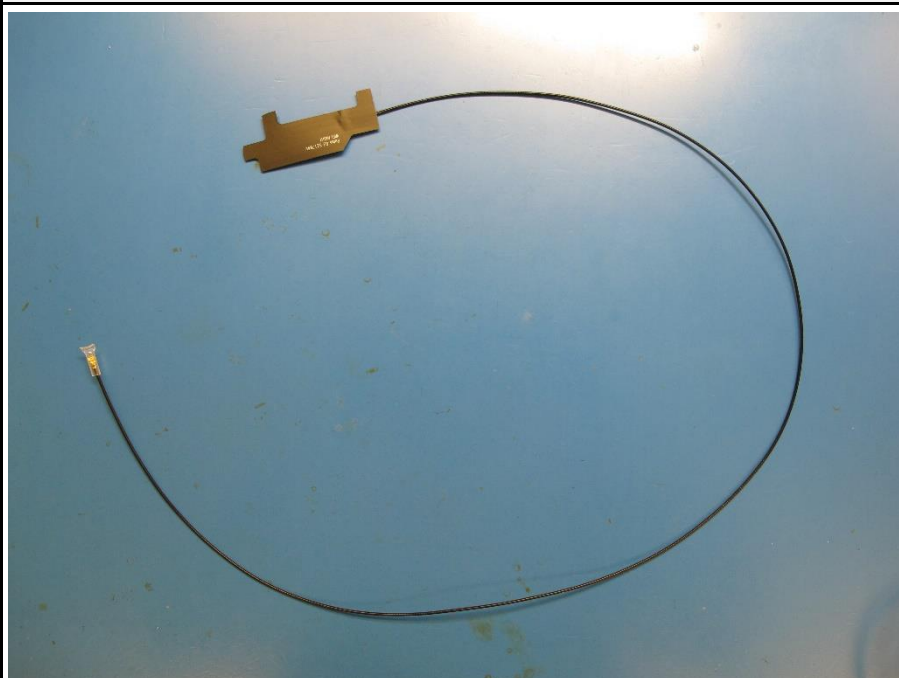

Note: Photo provided by customer

892583_mainboard_top

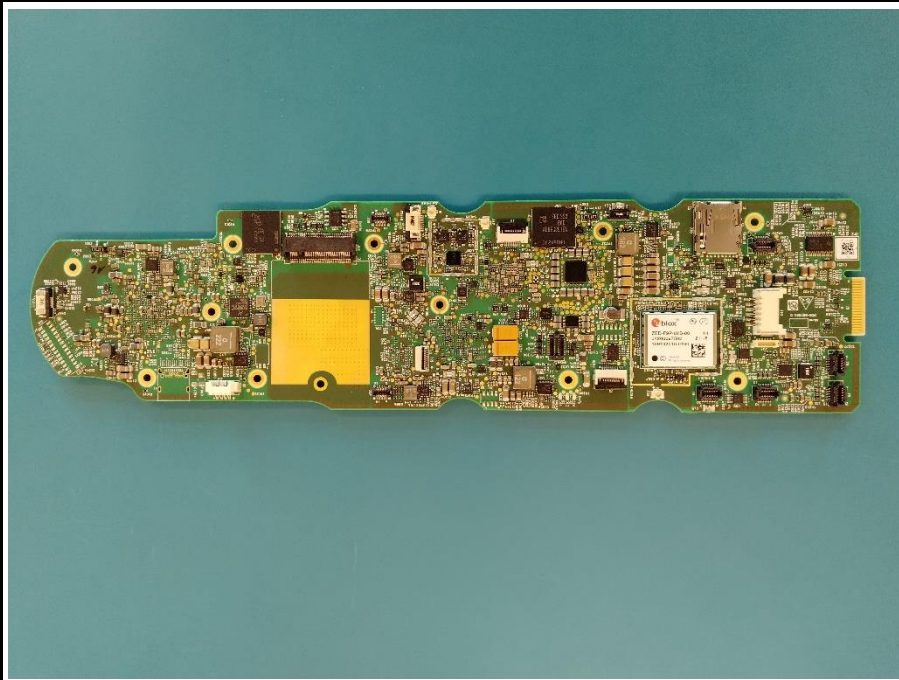

Note: Photo provided by customer

892583_mainboard_bottom



Note: Photo provided by customer

881218_Supercap-Board-TOP

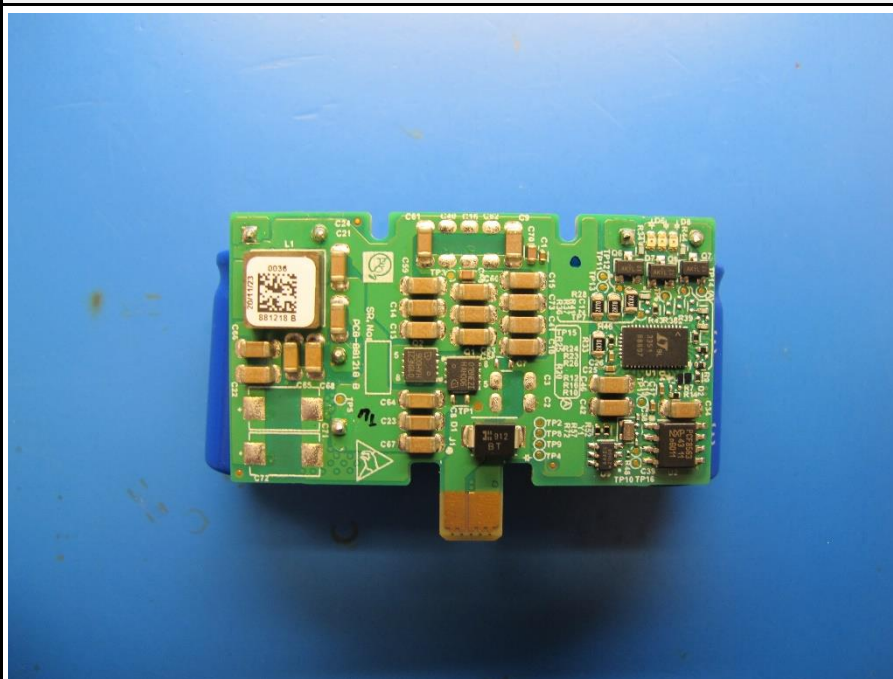

Note: Photo provided by customer

881218_Supercap-Board-BOTTOM

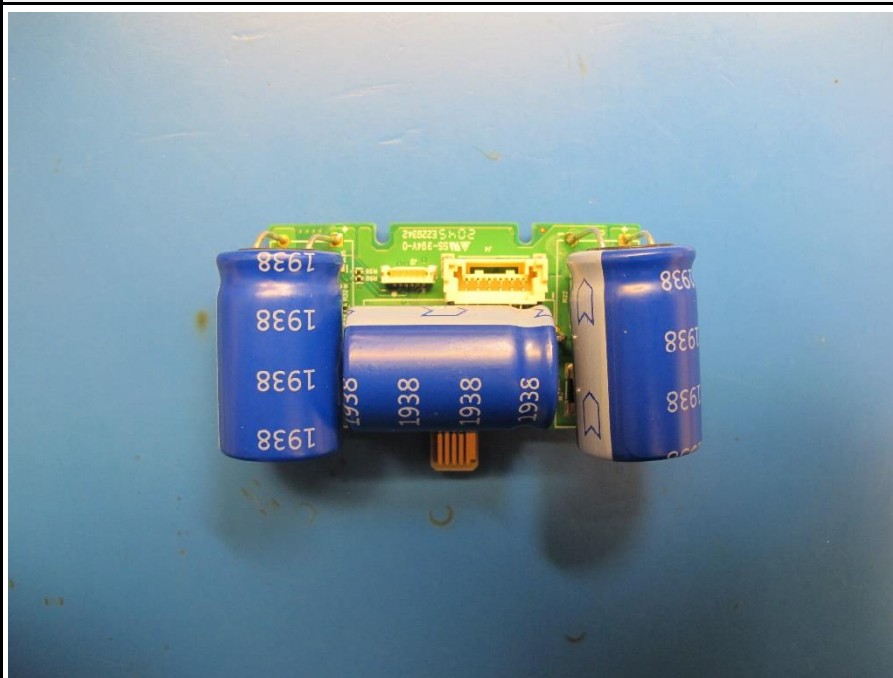

Note: Photo provided by customer

906419_Battery-Connector-Board_TOP

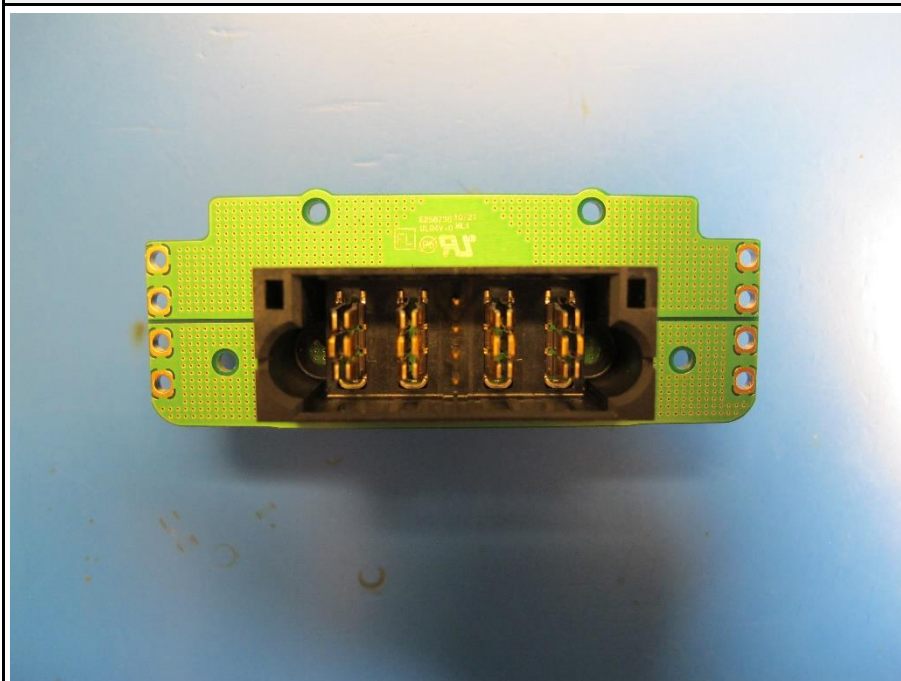

Note: Photo provided by customer

906419_Battery-Connector-Board_BOTTOM

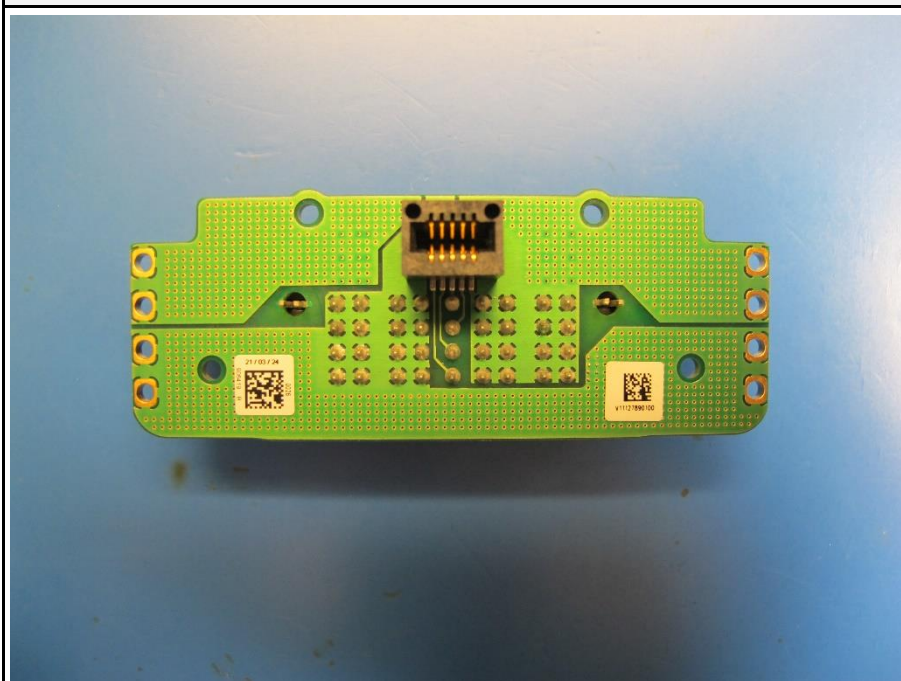

Note: Photo provided by customer

880880_Master_Radar-Board_TOP

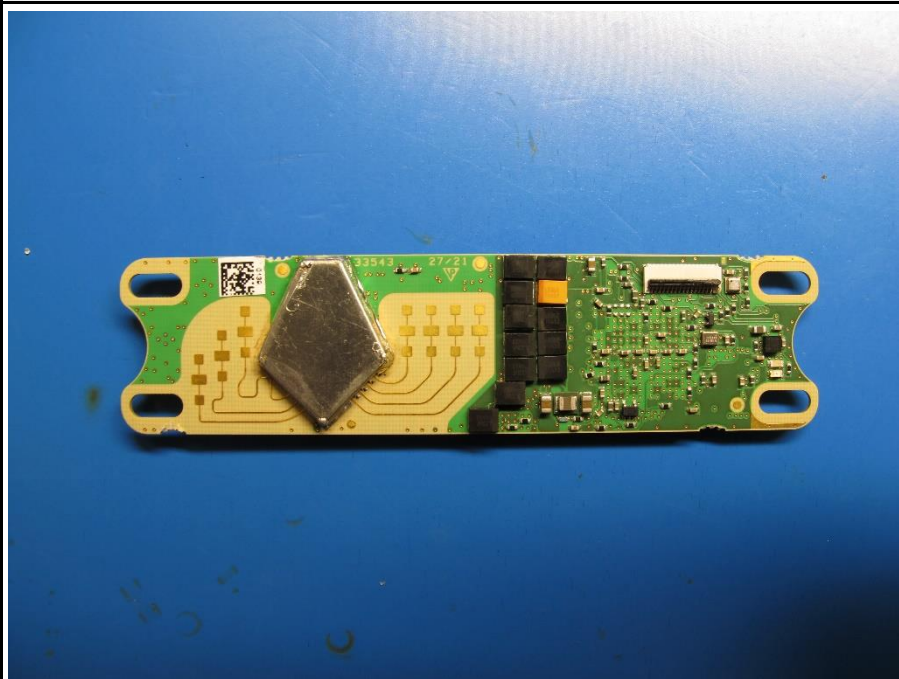

Note: Photo provided by customer

880880_Master_Radar-Board_BOTTOM

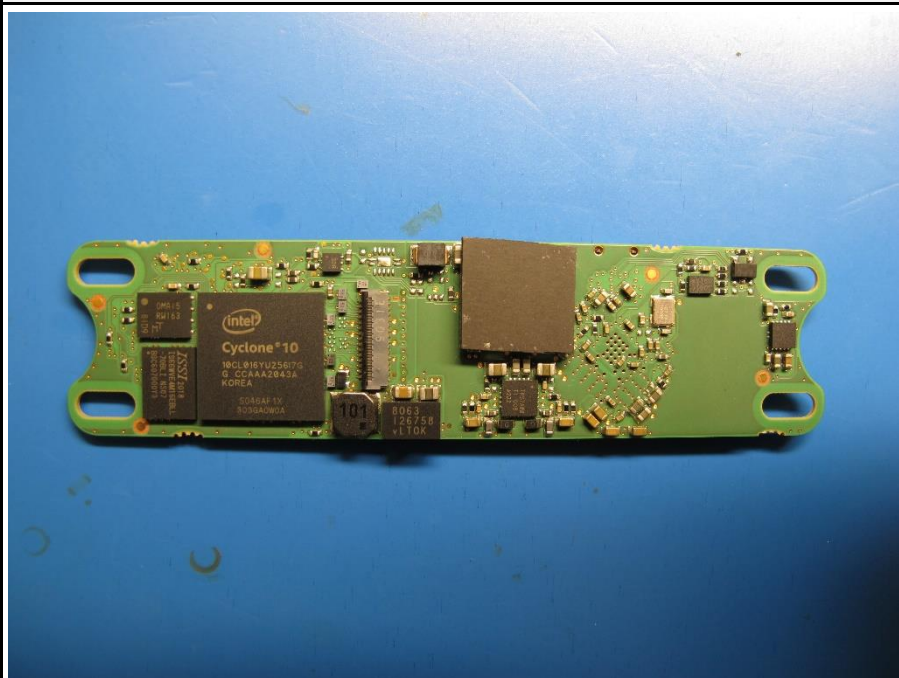

Note: Photo provided by customer

880870_Slave_Radar-Board_TOP

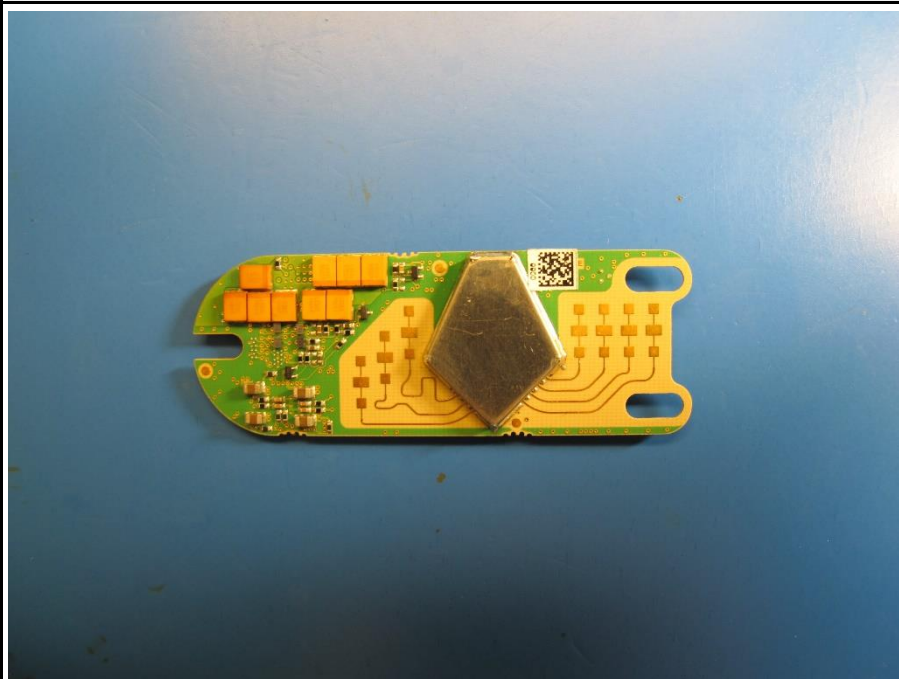

Note: Photo provided by customer

880870_Slave_Radar-Board_BOTTOM

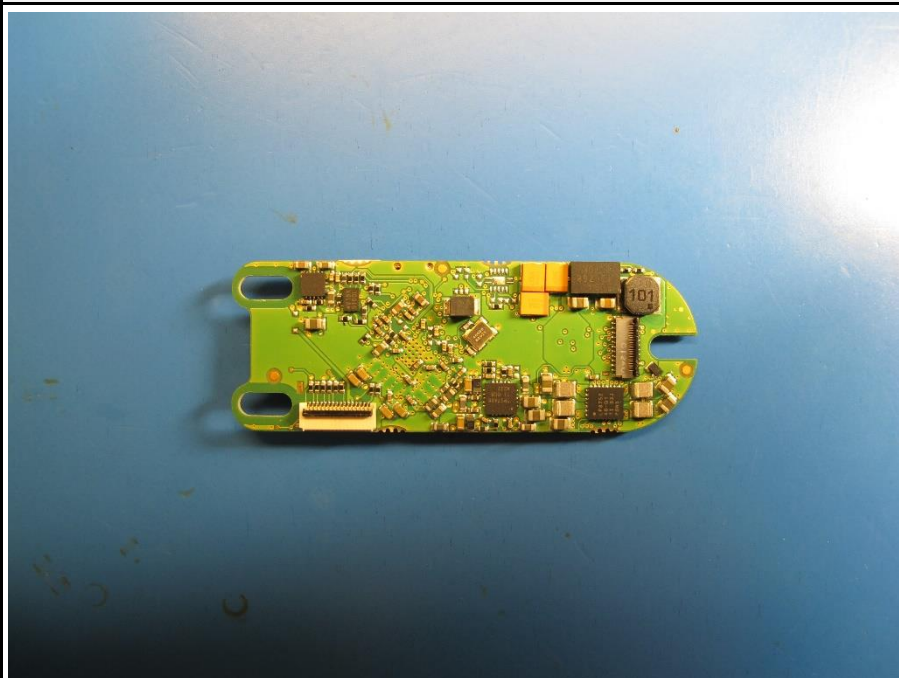

Note: Photo provided by customer

891019_ESC-Board_TOP

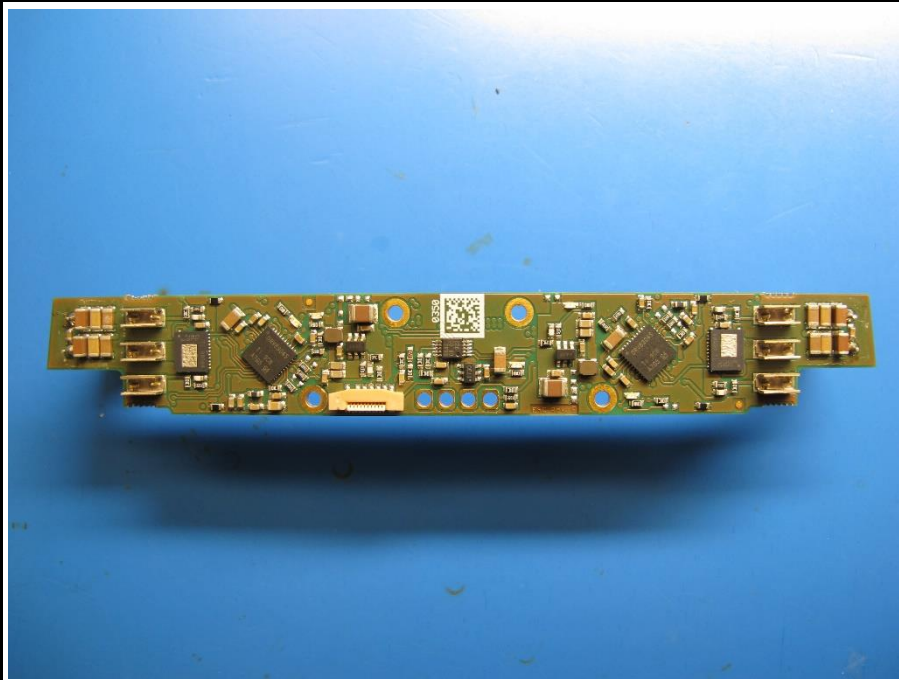

Note: Photo provided by customer

891019_ESC-Board_BOTTOM

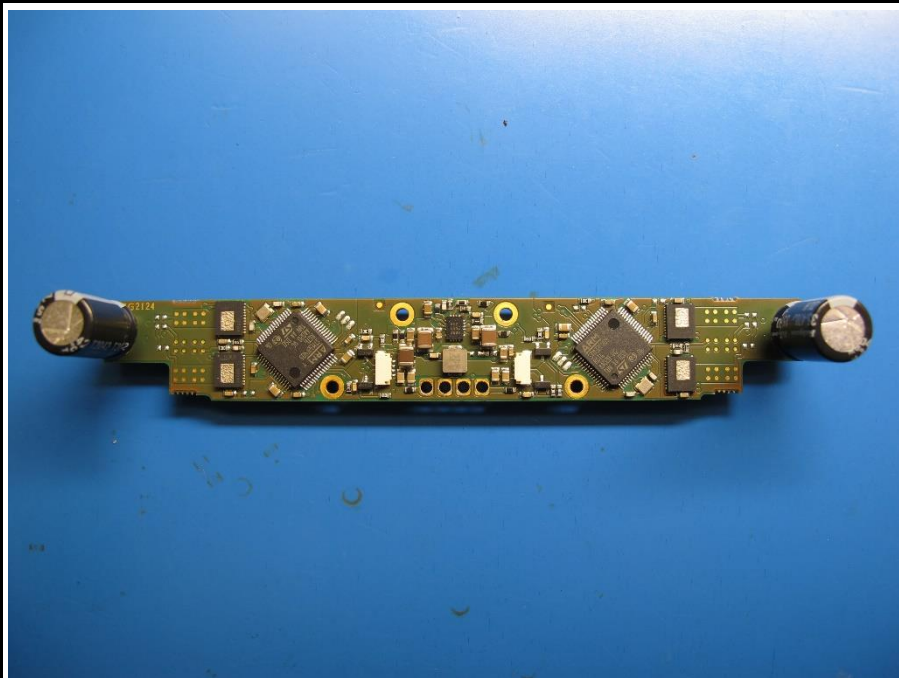

Note: Photo provided by customer

897756_LTE_top

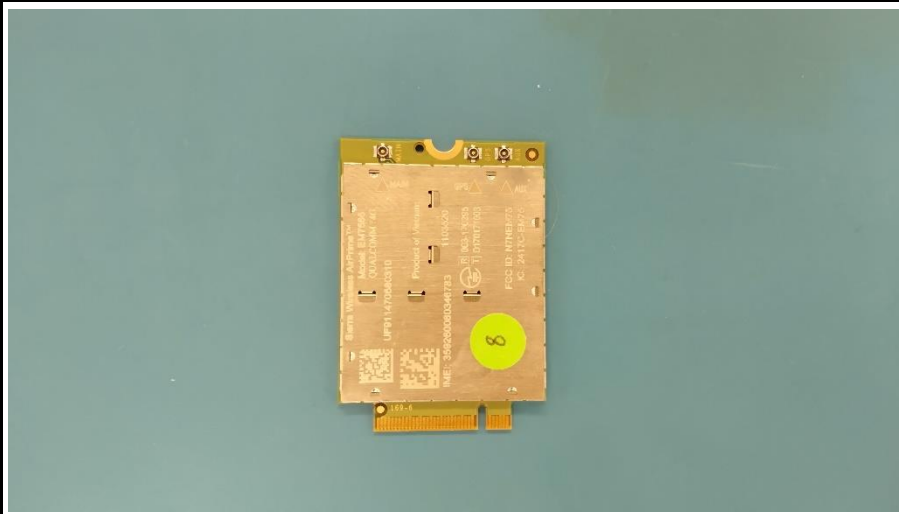

Note: Photo provided by customer

897756_LTE_bottom

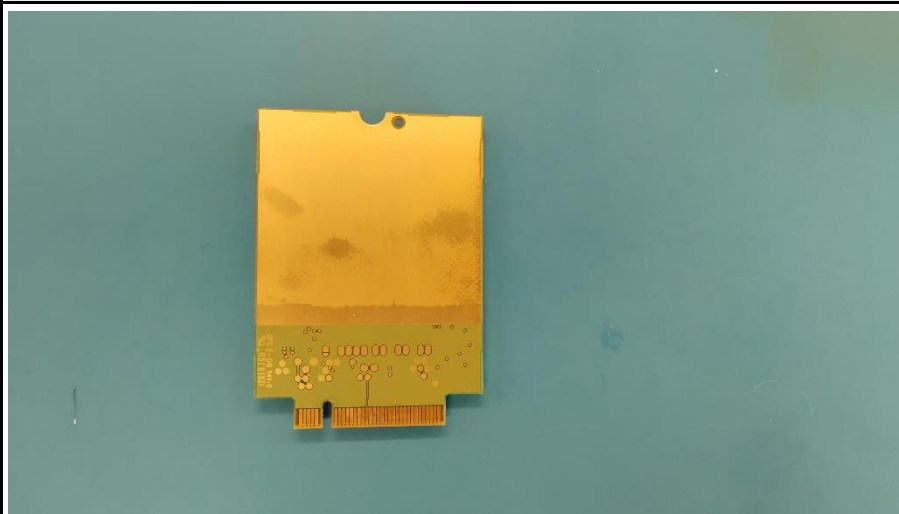

Note: Photo provided by customer

922381_Camera-Board_Portrait_TOP

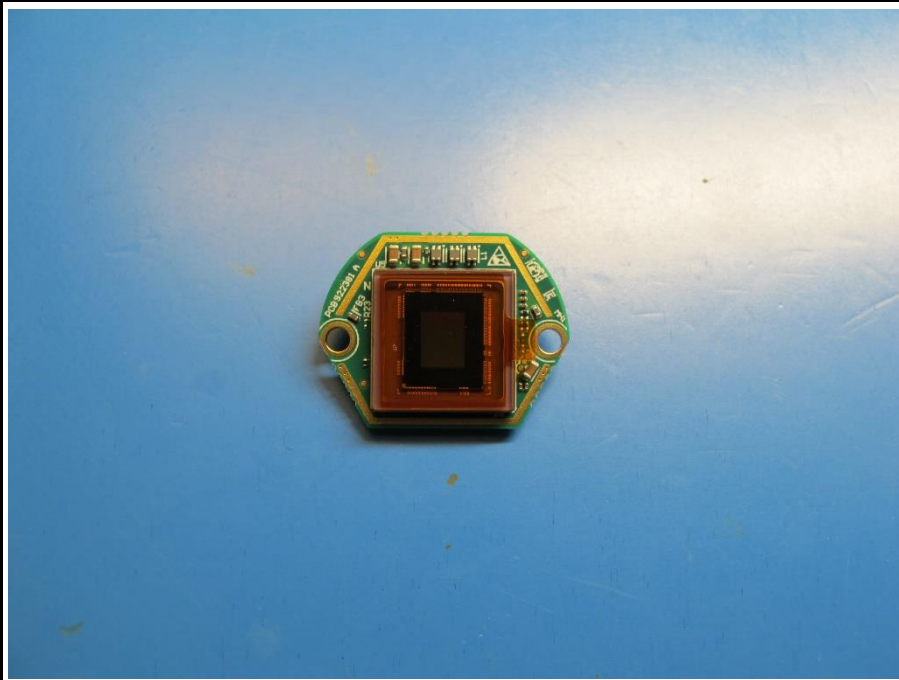

Note: Photo provided by customer

922381_Camera-Board_Portrait_BOTTOM

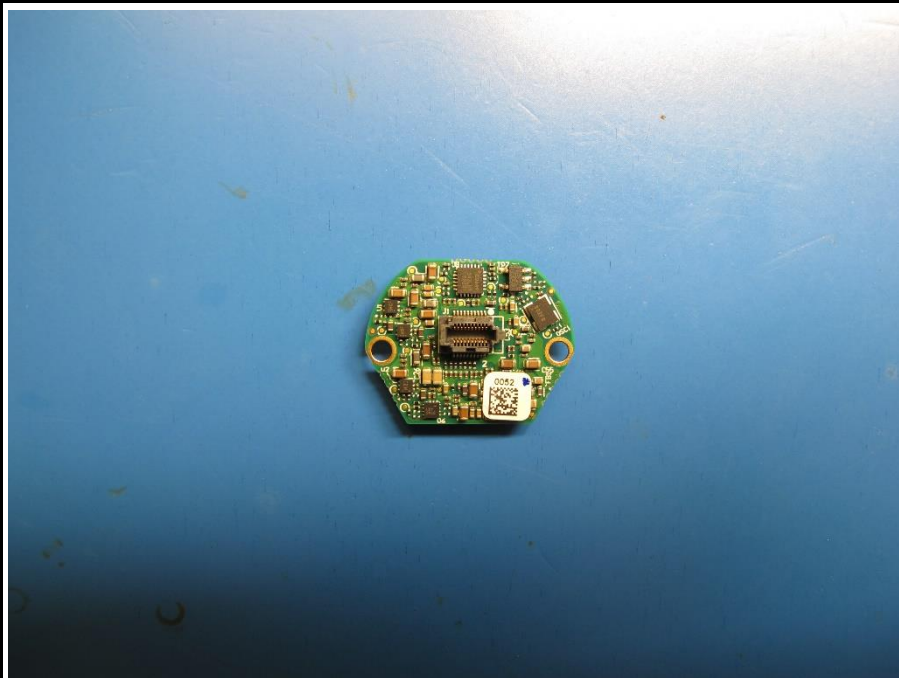

Note: Photo provided by customer

1.3 Photos – Test Setup

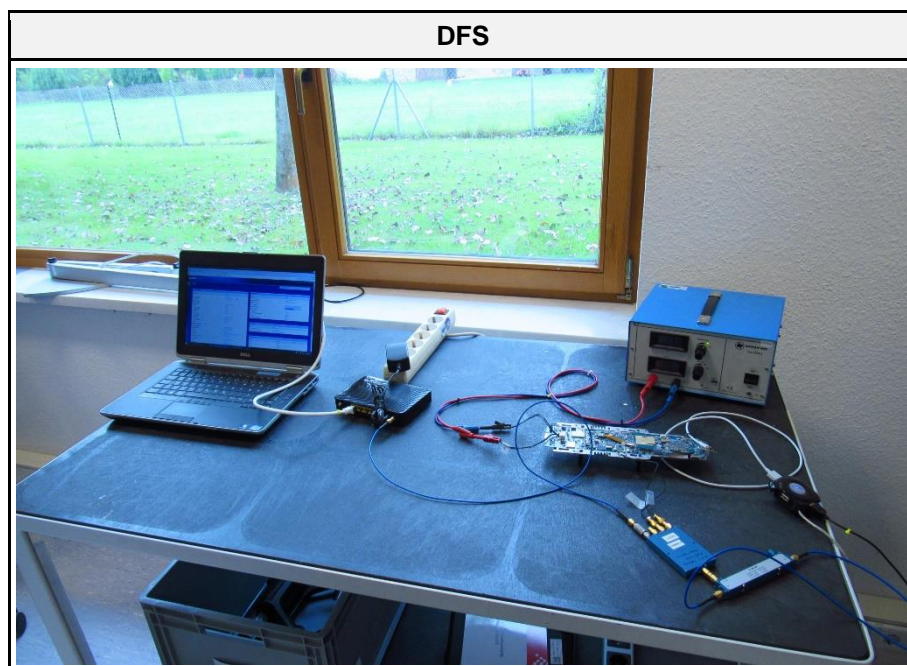
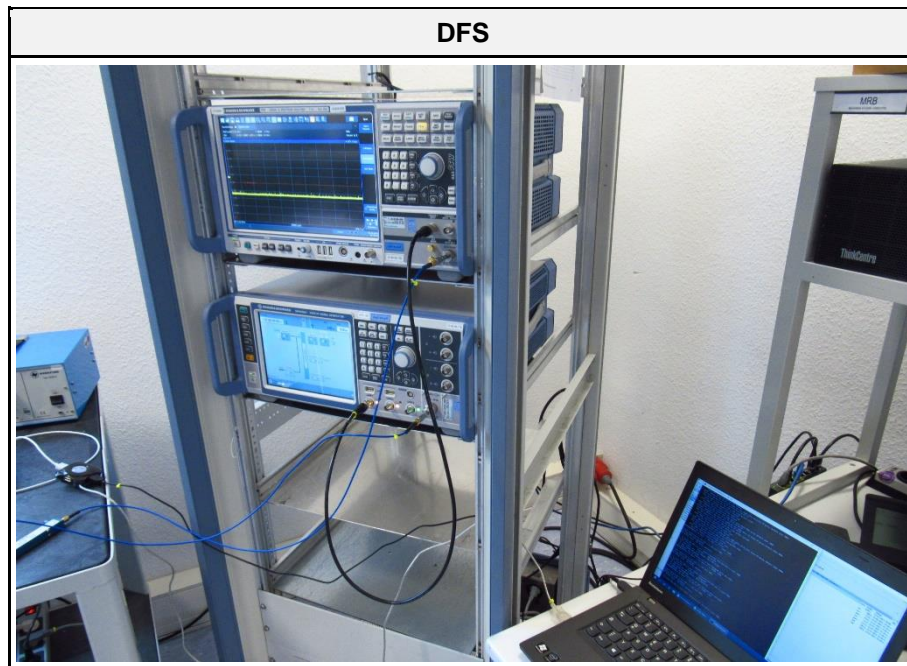

1.4 Support Equipment

Product Type	Device	Manufacturer	Model	Comment
AE	WiFi Access Point	ZyXel	NBG6503	FCC-ID: 2468C-NBG6503, for client testing
Description:				
AE	Auxiliary Equipment			
SIM	Simulator			
CBL	Connecting Cable			
SFT	Software			
Comment:				

1.5 Test Modes

Mode	Description
VHT80 (IEEE 802.11ac)	Mode = Transmit Bandwidth = 80 MHz Duty cycle = 20% Power setting (2 Simultaneous Tx) = 16

1.6 Test Frequencies

Designator	Mode	Channel	Frequency [MHz]
F3	Tx / Rx	100+104+108+112	5530

1.7 Normative References

References	
Designator	Reference
KDB 905462	KDB 905462 D02 v02
KDB 905462	KDB 905462 D03 v01r02
KDB 905462	KDB 905462 D04 v01
RSS-247	RSS-247 Issue 2

2 DFS Specifications

The following sections summarize the DFS requirements given in KDB 905462 D02

2.1 DFS Detection Thresholds

The DFS Detection Thresholds for Master Devices as well as Client Devices incorporating In-Service Monitoring

Maximum Transmit Power	Value (See Notes 1, 2, and 3)
EIRP \geq 200 milliwatt	-64 dBm
EIRP < 200 milliwatt and power spectral density < 10 dBm/MHz	-62 dBm
EIRP < 200 milliwatt that do not meet the power spectral density requirement	-64 dBm
<p>Note 1: This is the level at the input of the receiver assuming a 0 dBi receive antenna. Note 2: Throughout these test procedures an additional 1 dB has been added to the amplitude of the test transmission waveforms to account for variations in measurement equipment. This will ensure that the test signal is at or above the detection threshold level to trigger a DFS response. Note3: EIRP is based on the highest antenna gain. For MIMO devices refer to KDB Publication 662911 D01.</p>	

2.2 DFS Requirements prior to use of channel

The following table summaries the requirements for Master Devices and Client Devices prior to use of channel

Requirement	Operational Mode		
	Master	Client Without Radar Detection	Client With Radar Detection
<i>Non-Occupancy Period</i>	Yes	Not required	Yes
<i>DFS Detection Threshold</i>	Yes	Not required	Yes
<i>Channel Availability Check Time</i>	Yes	Not required	Not required
<i>U-NII Detection Bandwidth</i>	Yes	Not required	Yes

2.3 DFS Requirements during normal operation

The following table summaries the requirements for Master Devices and Client Devices during normal operation

Requirement	Operational Mode	
	Master Device or Client with Radar Detection	Client Without Radar Detection
<i>DFS Detection Threshold</i>	Yes	Not required
<i>Channel Closing Transmission Time</i>	Yes	Yes
<i>Channel Move Time</i>	Yes	Yes
<i>U-NII Detection Bandwidth</i>	Yes	Not required

2.4 DFS Requirements for EUTs with multiple bandwidth modes

The following table shows the tests and operational bandwidth for EUTs that support multiple bandwidth operational modes

Additional requirements for devices with multiple bandwidth modes	Master Device or Client with Radar Detection	Client Without Radar Detection
<i>U-NII Detection Bandwidth and Statistical Performance Check</i>	All BW modes must be tested	Not required
<i>Channel Move Time and Channel Closing Transmission Time</i>	Test using widest BW mode available	Test using the widest BW mode available for the link
<i>All other tests</i>	Any single BW mode	Not required
Note: Frequencies selected for statistical performance check (Section 7.8.4) should include several frequencies within the radar detection bandwidth and frequencies near the edge of the radar detection bandwidth. For 802.11 devices it is suggested to select frequencies in each of the bonded 20 MHz channels and the channel center frequency.		

2.5 DFS Response Requirements

For Master and Client Devices with radar detection the required response times are shown below

Parameter	Value
<i>Non-occupancy period</i>	Minimum 30 minutes
<i>Channel Availability Check Time</i>	60 seconds
<i>Channel Move Time</i>	10 seconds See Note 1.
<i>Channel Closing Transmission Time</i>	200 milliseconds + an aggregate of 60 milliseconds over remaining 10 second period. See Notes 1 and 2.
<i>U-NII Detection Bandwidth</i>	Minimum 100% of the U-NII 99% transmission power bandwidth. See Note 3.
Note 1: <i>Channel Move Time</i> and the <i>Channel Closing Transmission Time</i> should be performed with Radar Type 0. The measurement timing begins at the end of the Radar Type 0 burst. Note 2: The <i>Channel Closing Transmission Time</i> is comprised of 200 milliseconds starting at the beginning of the <i>Channel Move Time</i> plus any additional intermittent control signals required to facilitate a <i>Channel</i> move (an aggregate of 60 milliseconds) during the remainder of the 10 second period. The aggregate duration of control signals will not count quiet periods in between transmissions. Note 3: During the <i>U-NII Detection Bandwidth</i> detection test, radar type 0 should be used. For each frequency step the minimum percentage of detection is 90 percent. Measurements are performed with no data traffic.	

2.6 DFS Short Radar Waveforms

The following table shows the waveform parameters, minimum percentage of successful detection and the number of trials for the short radar waveforms Type 0 to 4

Radar Type	Pulse Width (µsec)	PRI (µsec)	Number of Pulses	Minimum Percentage of Successful Detection	Minimum Number of Trials
0	1	1428	18	See Note 1	See Note 1
1	1	Test A: 15 unique PRI values randomly selected from the list of 23 PRI values in Table 5a	Roundup $\left\{ \begin{matrix} \left(\frac{1}{360} \right) \cdot \\ \left(\frac{19 \cdot 10^6}{PRI_{\mu sec}} \right) \end{matrix} \right\}$	60%	30
		Test B: 15 unique PRI values randomly selected within the range of 518-3066 µsec, with a minimum increment of 1 µsec, excluding PRI values selected in Test A			
2	1-5	150-230	23-29	60%	30
3	6-10	200-500	16-18	60%	30
4	11-20	200-500	12-16	60%	30
Aggregate (Radar Types 1-4)				80%	120
Note 1: Short Pulse Radar Type 0 should be used for the detection bandwidth test, channel move time, and channel closing time tests.					

Pulse Repetition Frequency Number	Pulse Repetition Frequency (Pulses Per Second)	Pulse Repetition Interval (Microseconds)
1	1930.5	518
2	1858.7	538
3	1792.1	558
4	1730.1	578
5	1672.2	598
6	1618.1	618
7	1567.4	638
8	1519.8	658
9	1474.9	678
10	1432.7	698
11	1392.8	718
12	1355	738
13	1319.3	758
14	1285.3	778
15	1253.1	798
16	1222.5	818
17	1193.3	838
18	1165.6	858
19	1139	878
20	1113.6	898
21	1089.3	918
22	1066.1	938
23	326.2	3066

2.7 DFS Long Radar Waveform

The following table shows the waveform parameters, minimum percentage of successful detection and the number of trials for the long radar waveform Type 5

Radar Type	Pulse Width (µsec)	Chirp Width (MHz)	PRI (µsec)	Number of Pulses per Burst	Number of Bursts	Minimum Percentage of Successful Detection	Minimum Number of Trials
5	50-100	5-20	1000-2000	1-3	8-20	80%	30

The parameters for this waveform are randomly chosen. Thirty unique waveforms are required for the Long Pulse Radar Type waveforms. If more than 30 waveforms are used for the Long Pulse Radar Type waveforms, then each additional waveform must also be unique and not repeated from the previous waveforms.

Each waveform is defined as follows:

- 1) The transmission period for the Long Pulse Radar test signal is 12 seconds.
- 2) There are a total of 8 to 20 *Bursts* in the 12 second period, with the number of *Bursts* being randomly chosen. This number is *Burst Count*.
- 3) Each *Burst* consists of 1 to 3 pulses, with the number of pulses being randomly chosen. Each *Burst* within the 12 second sequence may have a different number of pulses.
- 4) The pulse width is between 50 and 100 microseconds, with the pulse width being randomly chosen. Each pulse within a *Burst* will have the same pulse width. Pulses in different *Bursts* may have different pulse widths.
- 5) Each pulse has a linear frequency modulated chirp between 5 and 20 MHz, with the chirp width being randomly chosen. Each pulse within a *transmission period* will have the same chirp width. The chirp is centered on the pulse. For example, with a radar frequency of 5300 MHz and a 20 MHz chirped signal, the chirp starts at 5290 MHz and ends at 5310 MHz.
- 6) If more than one pulse is present in a *Burst*, the time between the pulses will be between 1000 and 2000 microseconds, with the time being randomly chosen. If three pulses are present in a *Burst*, the random time interval between the first and second pulses is chosen independently of the random time interval between the second and third pulses.
- 7) The 12 second transmission period is divided into even intervals. The number of intervals is equal to *Burst Count*. Each interval is of length $(12,000,000 / \text{Burst Count})$ microseconds. Each interval contains one *Burst*. The start time for the *Burst*, relative to the beginning of the interval, is between 1 and $[(12,000,000 / \text{Burst Count}) - (\text{Total Burst Length}) + (\text{One Random PRI Interval})]$ microseconds, with the start time being randomly chosen. The step interval for the start time is 1 microsecond. The start time for each *Burst* is chosen randomly.

2.8 DFS Hopping Radar Waveform

The following table shows the waveform parameters, minimum percentage of successful detection and the number of trials for the long radar waveform Type 6

Radar Type	Pulse Width (µsec)	PRI (µsec)	Pulses per Hop	Hopping Rate (kHz)	Hopping Sequence Length (msec)	Minimum Percentage of Successful Detection	Minimum Number of Trials
6	1	333	9	0.333	300	70%	30

For the Frequency Hopping Radar Type, the same *Burst* parameters are used for each waveform. The hopping sequence is different for each waveform and a 100-length segment is selected from the hopping sequence defined by the following algorithm:⁴

The first frequency in a hopping sequence is selected randomly from the group of 475 integer frequencies from 5250 – 5724 MHz. Next, the frequency that was just chosen is removed from the group and a frequency is randomly selected from the remaining 474 frequencies in the group. This process continues until all 475 frequencies are chosen for the set. For selection of a random frequency, the frequencies remaining within the group are always treated as equally likely.

3 Result Summary

FCC 47 CFR Part 15E, ISED RSS-247				
Product Standard Reference	Requirement	Reference Method	Result	Remarks
FCC 15E.407 (h)(2) RSS-247 6.3	Waveform verification	KDB 905462 D02 v02 Section 7.5	N/R	
FCC 15E.407 (h)(2) RSS-247 6.3	Channel load verification	KDB 905462 D02 v02 Section 7.7	N/R	
FCC 15E.407 (h)(2) RSS-247 6.3	U-NII detection bandwidth	KDB 905462 D02 v02 Section 7.8.1	N/R	
FCC 15E.407 (h)(2) RSS-247 6.3	Initial Channel Availability Check Time	KDB 905462 D02 v02 Section 7.8.2.1	N/R	
FCC 15E.407 (h)(2) RSS-247 6.3	Radar Burst at the beginning of the Channel Availability Check Time	KDB 905462 D02 v02 Section 7.8.2.2	N/R	
FCC 15E.407 (h)(2) RSS-247 6.3	Radar Burst at the end of the Channel Availability Check Time	KDB 905462 D02 v02 Section 7.8.2.3	N/R	
FCC 15E.407 (h)(2) RSS-247 6.3	In-Service Monitoring for Channel Closing Transmission and Channel Move Time	KDB 905462 D02 v02 Section 7.8.3	PASS	
FCC 15E.407 (h)(2) RSS-247 6.3	In-Service Monitoring for Non-Occupancy Time	KDB 905462 D02 v02 Section 7.8.3	PASS	
FCC 15E.407 (h)(2) RSS-247 6.3	Statistical performance check	KDB 905462 D02 v02 Section 7.8.4	N/R	
Comment:				

Possible Test Case Verdicts	
PASS	Test object does meet the requirements
FAIL	Test object does not meet the requirements
N/T	Required by standard but not tested
N/R	Not required by standard for the test object

4 Test Conditions and Results

4.1 Test Conditions and Results - Channel Closing Transmission and Channel Move Time

4.1.1 Information

Test Information	
Reference	FCC 15E.407 (h)(2), RSS-247 6.3
Measurement Method	KDB 905462 D02 v02 Section 7.8.3
Operator	Toralf Jahn
Date	2021-10-04

4.1.2 Limits

Limits	
Maximum channel move time	10 s
Maximum channel closing transmission time	200 ms + aggregate of 60 ms

4.1.3 Setup

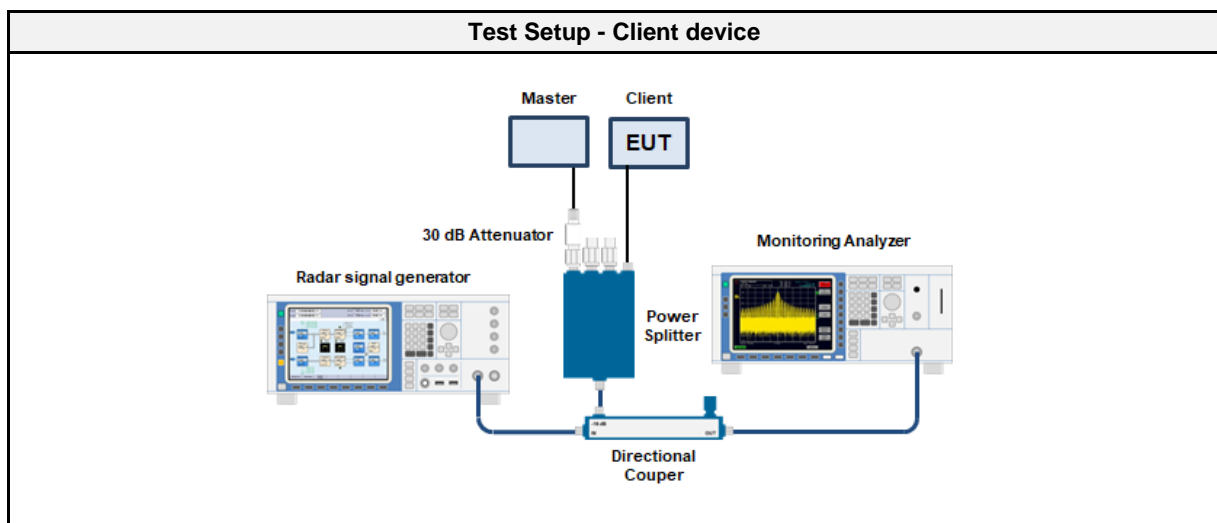
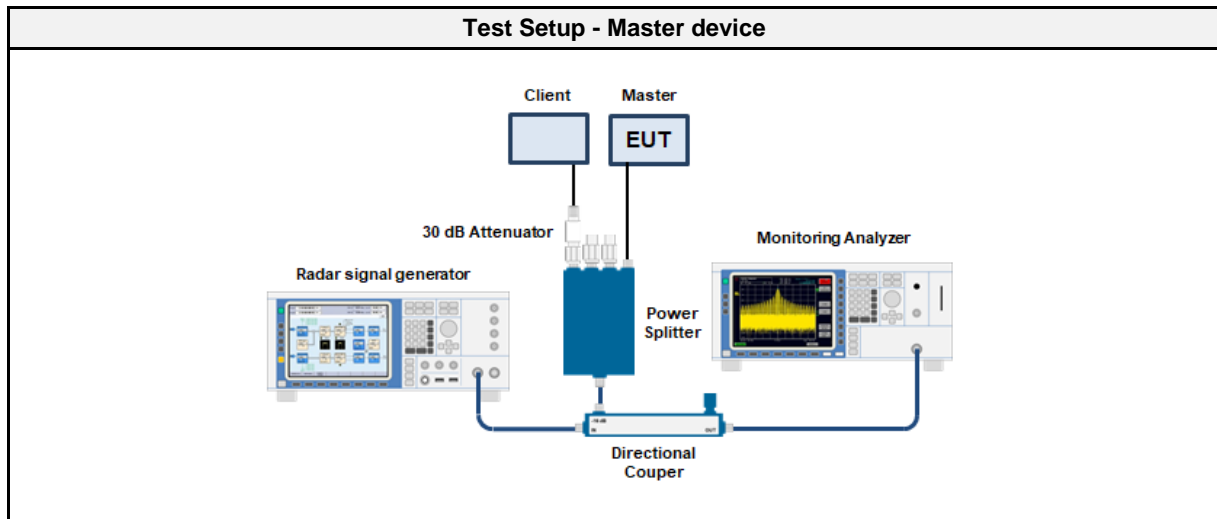

4.1.4 Equipment

Test Equipment					
Description	Manufacturer	Model	Identifier	Cal. Date	Cal. Due
Spectrum Analyzer	R&S	FSW 43	EF00896	2021-07	2022-07
Signal Generator	R&S	SMW 200A	EF01163	2021-08	2022-08

4.1.5 Procedure

Test Procedure
<ol style="list-style-type: none"> The waveform signal generator and the spectrum analyzer are set to the test frequency The spectrum analyzer is set to zero span with RBW = VBW = 3 MHz The sweep time is set to 16 s A channel loading stream is established between master and client At time T_0 a single radar burst of type 0 is send to the master with power level 1 dB above the DFS threshold level With the end of the burst the analyzer sweep is triggered and all emissions are recorded The analyzer trace is analyzed in order to determine the instance in time when all transmissions on the channel are stopped The result is recorded as channel move time The analyzer trace is analyzed in order to determine the accumulated transmission time between the end of the burst and the channel move time The result is recorded as channel closing transmission time

4.1.6 Results

Test Results - Client without radar detection		
Channel	Frequency [MHz]	Verdict
100+104+108+112	5530	PASS

DFS Channel moving and closing time

Project Number:	G0M-2011-9488
Applicant:	Leica Geosystems AG
Model Description:	UAV 3D measurement device
Model:	BLK2FLY
Test Sample ID:	34982
Reference Standards:	FCC 15.407
Reference Method:	KDB 905462 D02 v02
Operational Mode:	IEEE 802.11ac (VHT80), Channel: 106, 5530 MHz
Operating Conditions:	Tnom/Vnom
Operator:	Toralf Jahn
Test Site:	Eurofins Product Service GmbH
Test Date:	2021-10-05
EUT DFS Role:	Client without radar detection
Closing transmission time ≤ 200 ms [s]:	0.199 s
Closing transmission time > 200 ms [s]:	0.036 s
Channel move time [s]:	0.236 s
Closing time verdict:	PASS
Move time verdict:	PASS
Overall Verdict:	PASS

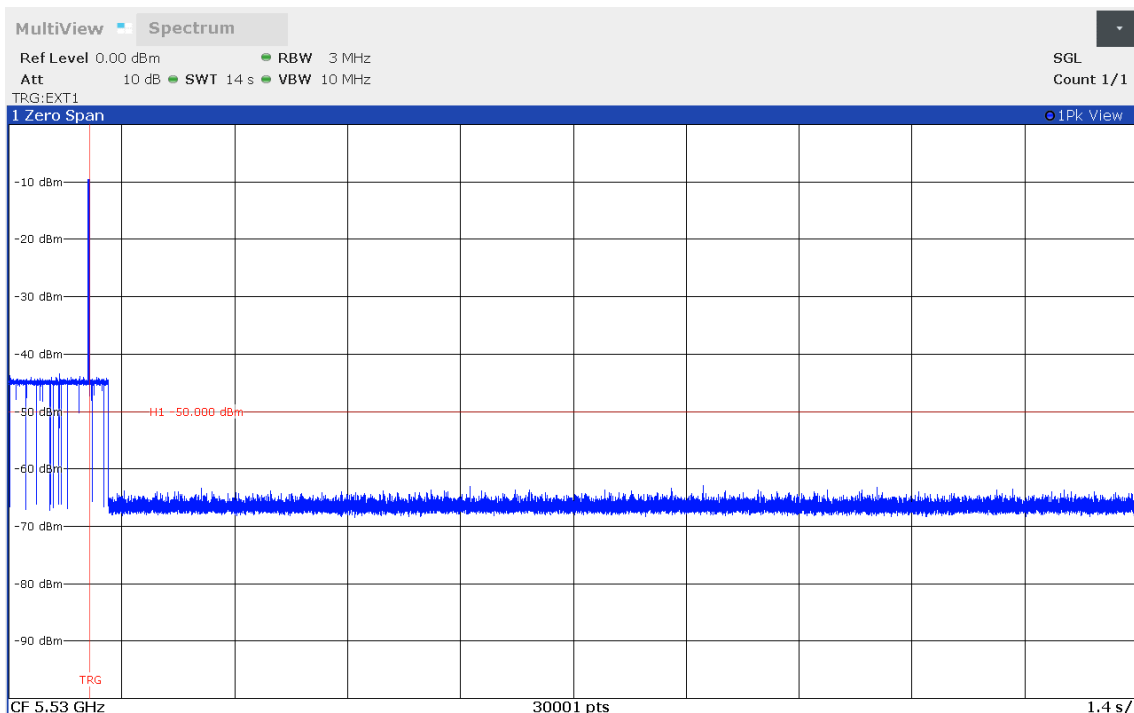

11:30:21 05.10.2021

4.2 Test Conditions and Results - Non-Occupancy Time

4.2.1 Information

Test Information	
Reference	FCC 15E.407 (h)(2), RSS-247 6.3
Measurement Method	KDB 905462 D02 v02 Section 7.8.3
Operator	Toralf Jahn
Date	2021-10-05

4.2.2 Limits

Limits
30 min

4.2.3 Setup

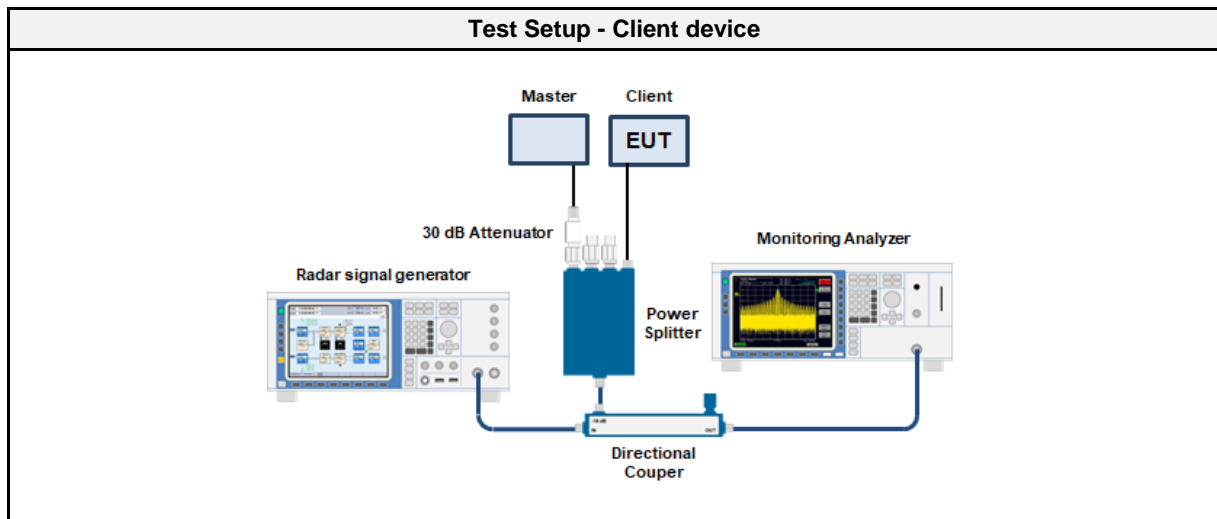
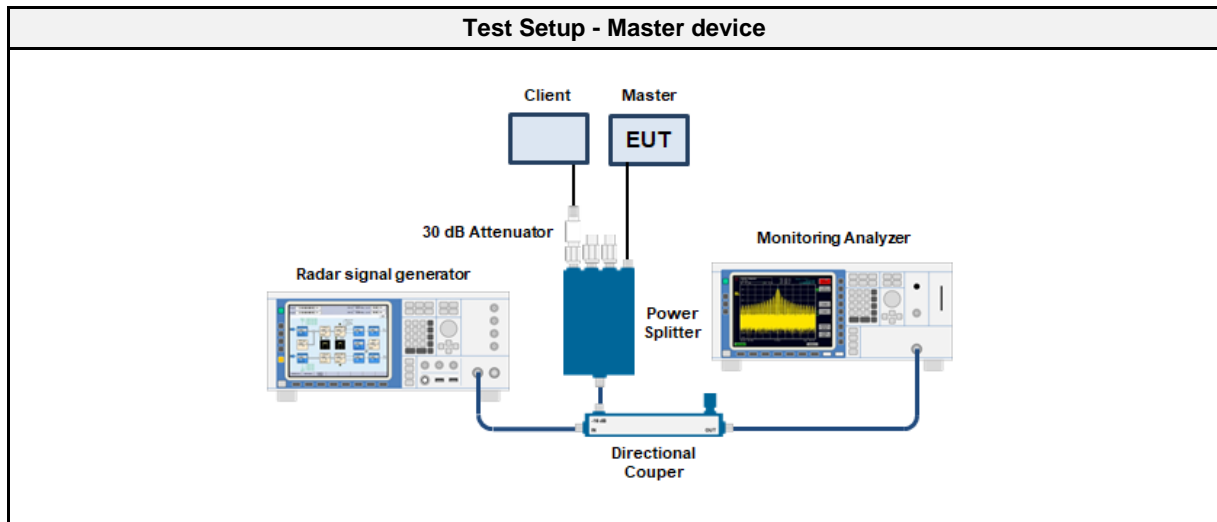

4.2.4 Equipment

Test Equipment					
Description	Manufacturer	Model	Identifier	Cal. Date	Cal. Due
Spectrum Analyzer	R&S	FSW 43	EF00896	2021-07	2022-07
Signal Generator	R&S	SMW 200A	EF01163	2021-08	2022-08

4.2.5 Procedure

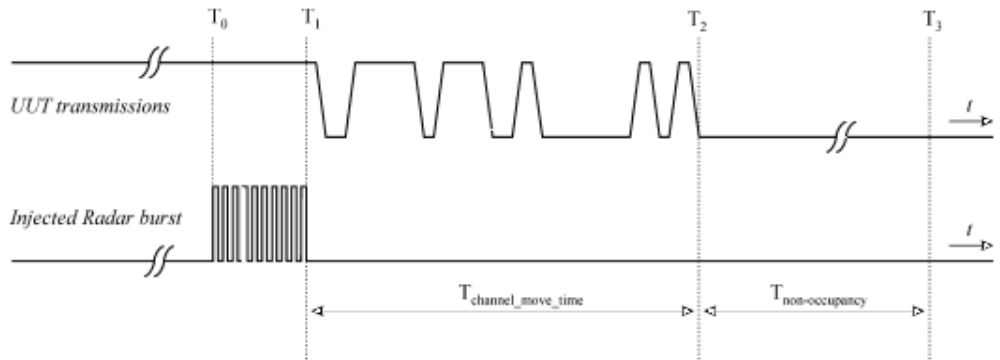
Test Procedure
<ol style="list-style-type: none"> 1. The waveform signal generator and the spectrum analyzer are set to the test frequency 2. The spectrum analyzer is set to zero span with RBW = VBW = 3 MHz 3. The sweep time is set to 2000 s 4. A channel loading stream is established between master and client 5. At time T_0 a single radar burst of type 0 is send to the master with a power level 1 dB above the DFS threshold level 6. With the end of the burst the analyzer sweep is triggered and all emissions are recorded 7. The analyzer trace is analyzed in order to determine the end of the channel move time T_2 8. The time after between the end of the channel move time is analyzed in order to determine whether the non-occupancy period is preserved 9. The duration of the silent period after the end of the end of the channel move time is recorded and compared to the limit

4.2.6 Results

Test Results - Client without radar detection			
Channel	Frequency [MHz]	Non-occupancy period [s]	Verdict
100+104+108+112	5530	>1800	PASS

DFS Non-occupancy period

Project Number:	G0M-2011-9488
Applicant:	Leica Geosystems AG
Model Description:	UAV 3D measurement device
Model:	BLK2FLY
Test Sample ID:	34982
Reference Standards:	FCC 15.407
Reference Method:	KDB 905462 D02 v02
Operational Mode:	IEEE 802.11ac (VHT80), Channel: 106, 5530 MHz
Operating Conditions:	Tnom/Vnom
Operator:	Toralf Jahn
Test Site:	Eurofins Product Service GmbH
Test Date:	2021-10-05
EUT DFS Role:	Client without radar detection

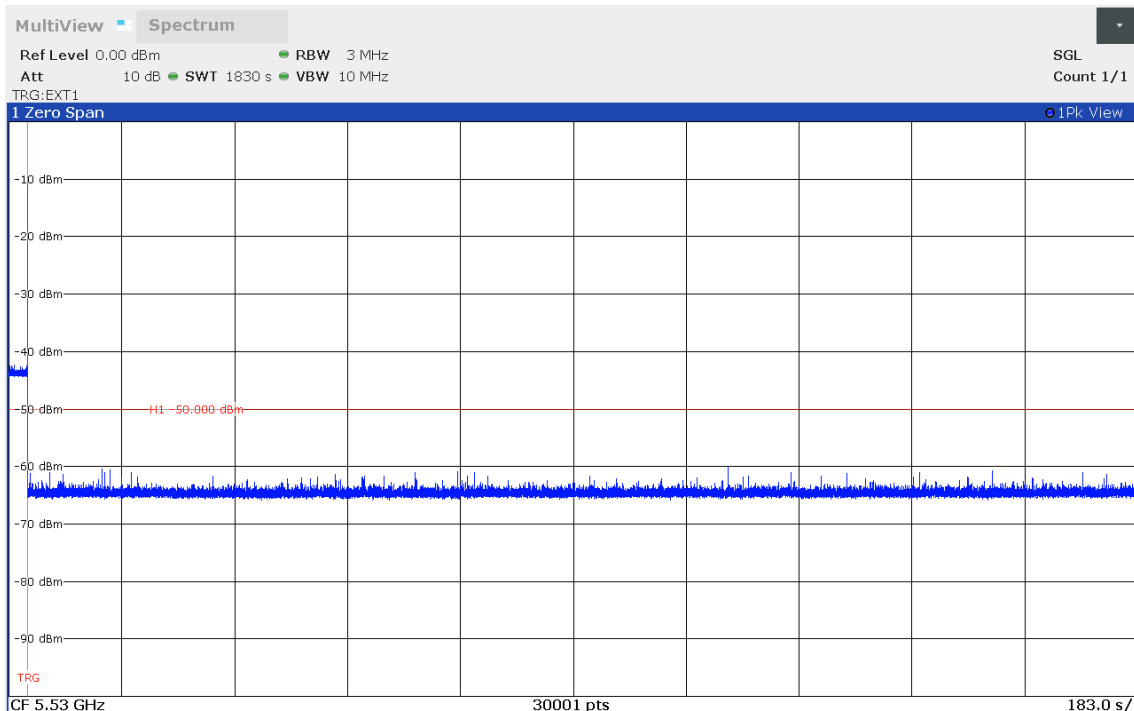

12:48:11 05.10.2021

=== END OF TEST REPORT ===