

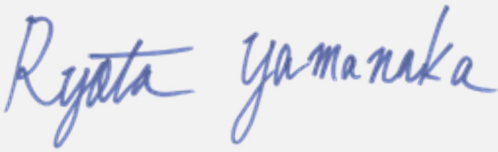

# RADIO TEST REPORT

Test Report No.: 14862952H-A-R2

Customer	Keyence Corporation
Description of EUT	Level sensor
Model Number of EUT	FR-SH01
FCC ID	RF41754B
Test Regulation	FCC Part 15 Subpart C
Test Result	Complied
Issue Date	September 28, 2023
Remarks	-

<b>Representative test engineer</b>	<b>Approved by</b>
	
Sayaka Hara Engineer	Ryota Yamanaka Engineer
	
	
CERTIFICATE 5107.02	
<input type="checkbox"/> The testing in which "Non-accreditation" is displayed is outside the accreditation scopes in UL Japan, Inc.	
<input checked="" type="checkbox"/> There is no testing item of "Non-accreditation".	

Report Cover Page - Form-ULID-003532 (DCS:13-EM-F0429) Issue# 22.0

## ANNOUNCEMENT

- This test report shall not be reproduced in full or partial, without the written approval of UL Japan, Inc.
- The results in this report apply only to the sample tested. (Laboratory was not involved in sampling.)
- This sample tested is in compliance with the limits of the above regulation.
- The test results in this test report are traceable to the national or international standards.
- This test report must not be used by the customer to claim product certification, approval, or endorsement by the A2LA accreditation body.
- This test report covers Radio technical requirements.  
It does not cover administrative issues such as Manual or non-Radio test related Requirements. (if applicable)
- The all test items in this test report are conducted by UL Japan, Inc. Ise EMC Lab.
- The opinions and the interpretations to the result of the description in this report are outside scopes where UL Japan, Inc. has been accredited.
- The information provided from the customer for this report is identified in Section 1.
- For test report(s) referred in this report, the latest version (including any revisions) is always referred.

## REVISION HISTORY

### Original Test Report No.: 14862952H-A

This report is a revised version of 14862952H-A-R1. 14862952H-A-R1 is replaced with this report.

Revision	Test Report No.	Date	Page Revised Contents
- (Original)	14862952H-A	September 22, 2023	-
1	14862952H-A-R1	September 27, 2023	Correction of the Operating temperature in Clause 2.2; from "-20 deg. C to 55 deg. C" to "-20 deg. C to 70 deg. C"
1	14862952H-A-R1	September 27, 2023	Correction of the note *1) in Clause 3.2
1	14862952H-A-R1	September 27, 2023	Correction of the Remarks in -20 dBc Frequency Result (Reference) table for Frequency Stability test; from "85 % of the minimum operating voltage, DC 12 V* 0.85" to "85 % of the rated voltage, DC 24 V* 0.85" from "115 % of the maximum operating voltage, DC 12 V* 1.15" to "115 % of the rated voltage, DC 24 V* 1.15" (page: 29, 32, 35, 38, 41)
1	14862952H-A-R1	September 27, 2023	Correction of the Last Calibration Date for MCH-04 in APPENDIX 2
2	14862952H-A-R2	September 28, 2023	Remodification of the note *1) in Clause 3.2.
2	14862952H-A-R2	September 28, 2023	Correction of the calculation formula for Duty Cycle, Off Time Requirement test

**Reference: Abbreviations (Including words undescribed in this report)**

A2LA	The American Association for Laboratory Accreditation	ICES	Interference-Causing Equipment Standard
AC	Alternating Current	IEC	International Electrotechnical Commission
AFH	Adaptive Frequency Hopping	IEEE	Institute of Electrical and Electronics Engineers
AM	Amplitude Modulation	IF	Intermediate Frequency
Amp, AMP	Amplifier	ILAC	International Laboratory Accreditation Conference
ANSI	American National Standards Institute	ISED	Innovation, Science and Economic Development Canada
Ant, ANT	Antenna	ISO	International Organization for Standardization
AP	Access Point	JAB	Japan Accreditation Board
ASK	Amplitude Shift Keying	LAN	Local Area Network
Atten., ATT	Attenuator	LIMS	Laboratory Information Management System
AV	Average	MCS	Modulation and Coding Scheme
BPSK	Binary Phase-Shift Keying	MRA	Mutual Recognition Arrangement
BR	Bluetooth Basic Rate	N/A	Not Applicable
BT	Bluetooth	NIST	National Institute of Standards and Technology
BT LE	Bluetooth Low Energy	NS	No signal detect.
BW	BandWidth	NSA	Normalized Site Attenuation
Cal Int	Calibration Interval	NVLAP	National Voluntary Laboratory Accreditation Program
CCK	Complementary Code Keying	OBW	Occupied Band Width
Ch., CH	Channel	OFDM	Orthogonal Frequency Division Multiplexing
CISPR	Comite International Special des Perturbations Radioelectriques	P/M	Power meter
CW	Continuous Wave	PCB	Printed Circuit Board
DBPSK	Differential BPSK	PER	Packet Error Rate
DC	Direct Current	PHY	Physical Layer
D-factor	Distance factor	PK	Peak
DFS	Dynamic Frequency Selection	PN	Pseudo random Noise
DQPSK	Differential QPSK	PRBS	Pseudo-Random Bit Sequence
DSSS	Direct Sequence Spread Spectrum	PSD	Power Spectral Density
EDR	Enhanced Data Rate	QAM	Quadrature Amplitude Modulation
EIRP, e.i.r.p.	Equivalent Isotropically Radiated Power	QP	Quasi-Peak
EMC	ElectroMagnetic Compatibility	QPSK	Quadri-Phase Shift Keying
EMI	ElectroMagnetic Interference	RBW	Resolution Band Width
EN	European Norm	RDS	Radio Data System
ERP, e.r.p.	Effective Radiated Power	RE	Radio Equipment
EU	European Union	RF	Radio Frequency
EUT	Equipment Under Test	RMS	Root Mean Square
Fac.	Factor	RSS	Radio Standards Specifications
FCC	Federal Communications Commission	Rx	Receiving
FHSS	Frequency Hopping Spread Spectrum	SA, S/A	Spectrum Analyzer
FM	Frequency Modulation	SG	Signal Generator
Freq.	Frequency	SVSWR	Site-Voltage Standing Wave Ratio
FSK	Frequency Shift Keying	TR	Test Receiver
GFSK	Gaussian Frequency-Shift Keying	Tx	Transmitting
GNSS	Global Navigation Satellite System	VBW	Video BandWidth
GPS	Global Positioning System	Vert.	Vertical
Hori.	Horizontal	WLAN	Wireless LAN

---

<b>CONTENTS</b>	<b>PAGE</b>
<b>SECTION 1: Customer Information.....</b>	<b>5</b>
<b>SECTION 2: Equipment Under Test (EUT) .....</b>	<b>5</b>
<b>SECTION 3: Test specification, procedures &amp; results .....</b>	<b>6</b>
<b>SECTION 4: Operation of EUT during testing.....</b>	<b>9</b>
<b>SECTION 5: Conducted Emission .....</b>	<b>12</b>
<b>SECTION 6: Radiated Emissions .....</b>	<b>13</b>
<b>SECTION 7: Frequency Stability .....</b>	<b>19</b>
<b>APPENDIX 1: Test data .....</b>	<b>20</b>
Conducted Emission .....	20
Duty Cycle, Off Time Requirement .....	21
20 dB Bandwidth.....	22
EIRP(Peak).....	24
Spurious Emissions .....	26
Frequency Stability .....	29
Group Instillation.....	44
<b>APPENDIX 2: Test instruments.....</b>	<b>45</b>
<b>APPENDIX 3: Photographs of test setup .....</b>	<b>48</b>
Conducted Emission .....	48
EIRP .....	49
Spurious Emissions .....	50
Worst Case Position .....	53
Frequency Stability .....	54

## **SECTION 1: Customer Information**

Company Name	Keyence Corporation
Address	1-3-14, Higashinakajima Higashiyodogwa-ku, Osaka, 533-8555 Japan
Telephone Number	+81-6-6379-1111
Contact Person	Takashi Suzuki

The information provided from the customer is as follows;

- Customer, Description of EUT, Model Number of EUT, FCC ID on the cover and other relevant pages
- Operating/Test Mode(s) (Mode(s)) on all the relevant pages
- SECTION 1: Customer Information
- SECTION 2: Equipment Under Test (EUT) other than the Receipt Date and Test Date
- SECTION 4: Operation of EUT during testing

\* The laboratory is exempted from liability of any test results affected from the above information in SECTION 2 and 4.

## **SECTION 2: Equipment Under Test (EUT)**

### **2.1 Identification of EUT**

Description	Level sensor
Model Number	FR-SH01
Serial Number	Refer to SECTION 4.2
Condition	Production prototype (Not for Sale: This sample is equivalent to mass-produced items.)
Modification	No Modification by the test lab
Receipt Date	July 10, 2023
Test Date	July 10 to 27, 2023

### **2.2 Product Description**

#### **General Specification**

Rating	DC 24 V
Operating temperature	-20 deg. C to 70 deg. C

#### **Radio Specification**

Equipment Type	Transceiver
Frequency of Operation	60.5 GHz (Center) (58 GHz to 63 GHz)
Bandwidth	5 GHz
Type of Modulation	Frequency modulation (FMCW)
Antenna Gain	18.8 dBi
Steerable Antenna	Electrically
Usage location	Fixed Field disturbance sensor

### **2.3 Variant model(s)**

Tested model: FR-SH01 has a variant model: FR-SH01C.

FR-SH01 and FR-SH01C are same body and same circuit, but these 2 models have different cord.

- FR-SH01 has cord with loose wire for user wiring.
- FR-SH01C has cord with connector for easy set up.

## SECTION 3: Test specification, procedures & results

### 3.1 Test Specification

Test Specification	FCC Part 15 Subpart C The latest version on the first day of the testing period
Title	FCC 47CFR Part15 Radio Frequency Device Subpart C Intentional Radiators Section 15.207 Conducted limits. Section 15.255 Operation within the band 57-71 GHz.

### 3.2 Procedures and results

Item	Test Procedure	Specification	Worst margin	Results	Remarks
Conducted Emission	FCC: ANSI C63.10-2013, 6. Standard test methods	FCC: Section 15.207	24.53 dB, 0.16107 MHz, AV Phase N	Complied	-
Duty cycle, Off Time Requirement	FCC: -	FCC: Section FCC 15.255 (c)(2)(iii)(A)	See data.	Complied	Radiated
6dB Bandwidth	FCC: Section 15.255(e) (2) ANSI C63.10 2013, 9. Procedures for testing millimeter-wave systems	FCC: Section 15.255(e) (1)	-	N/A	*1)
20dB Bandwidth	FCC: ANSI C63.10 2013, 6. Standard test methods	FCC: Section 15.215 (c)	See data.	Complied	Radiated
EIRP	FCC: ANSI C63.10 2013, 9. Procedures for testing millimeter-wave systems	FCC: Section 15.255 (c)(2)(iii)(A)	See data.	Complied	Radiated
Spurious Emissions	FCC: ANSI C63.10 2013, 6. Standard test methods 9. Procedures for testing millimeter-wave systems	FCC: Section 15.255(d) Section 15.209	15.0 dB 416.0 MHz, QP, Vertical	Complied	Radiated
Frequency Stability	FCC: ANSI C63.10 2013, 9. Procedures for testing millimeter-wave systems	FCC: Section 15.255(f)	See data.	Complied	Radiated
Group Installation	FCC: -	FCC: Section 15.255(h)	-	N/A	*2)

Note: UL Japan, Inc.'s EMI Work Procedures: Work Instructions-ULID-003591 and Work Instructions-ULID-003593.  
\*1) The test is not applicable since the application of Section 15.255(e) is unnecessary due to the application of Section 15.255(c)(2)(iii)(A).  
\*2) The test is not applicable since there are no external phase-locking inputs in this EUT.

#### **FCC Part 15.31 (e)**

This EUT provides the stable voltage constantly to RF Module regardless of input voltage.  
Therefore, this EUT complies with the requirement.

#### **FCC Part 15.203 Antenna requirement**

The antenna is not removable from the EUT.  
Therefore, the equipment complies with the antenna requirement of Section 15.203.

### 3.3 Addition to standard

No addition, deviation, nor exclusion has been made from standards.

### 3.4 Uncertainty

Measurement uncertainty is not taken into account when stating conformity with a specified requirement.  
Note: When margins obtained from test results are less than the measurement uncertainty, the test results may exceed the limit.

The following uncertainties have been calculated to provide a confidence level of 95 % using a coverage factor  $k = 2$ .

#### Conducted emission

Using Item	Frequency range	Uncertainty (+/-)
AMN (LISN)	0.009 MHz to 0.15 MHz	3.7 dB
	0.15 MHz to 30 MHz	3.3 dB

#### Radiated emission

Measurement distance	Frequency range		Uncertainty (+/-)
3 m	9 kHz to 30 MHz		3.3 dB
10 m			3.1 dB
3 m	30 MHz to 200 MHz	Horizontal	4.8 dB
		Vertical	5.0 dB
	200 MHz to 1000 MHz	Horizontal	5.1 dB
		Vertical	6.2 dB
10 m	30 MHz to 200 MHz	Horizontal	4.8 dB
		Vertical	4.8 dB
	200 MHz to 1000 MHz	Horizontal	4.9 dB
		Vertical	5.0 dB
3 m	1 GHz to 6 GHz	Test Receiver	5.0 dB
		Spectrum analyzer	4.9 dB
	6 GHz to 18 GHz	Test Receiver	5.3 dB
		Spectrum analyzer	5.2 dB
1 m	10 GHz to 26.5 GHz	Spectrum analyzer	5.5 dB
	26.5 GHz to 40 GHz	Spectrum analyzer	5.4 dB
0.5 m	26.5 GHz to 40 GHz	Spectrum analyzer	5.4 dB
10 m	1 GHz to 18 GHz	Test Receiver	5.3 dB
>= 0.5 m	40 GHz to 50 GHz		4.2 dB
>= 0.5 m	50 GHz to 75 GHz		5.9 dB
>= 0.5 m	75 GHz to 110 GHz		5.5 dB
>= 3.8 cm	110 GHz to 170 GHz		5.8 dB
>= 2.5 cm	170 GHz to 260 GHz		5.0 dB

### 3.5 Test Location

UL Japan, Inc. Ise EMC Lab.

4383-326 Asama-cho, Ise-shi, Mie-ken 516-0021 Japan

Telephone: +81-596-24-8999

A2LA Certificate Number: 5107.02 / FCC Test Firm Registration Number: 884919

ISED Lab Company Number: 2973C / CAB identifier: JP0002

Test site	Width x Depth x Height (m)	Size of reference ground plane (m) / horizontal conducting plane	Other rooms	Maximum measurement distance
No.1 semi-anechoic chamber	19.2 x 11.2 x 7.7	7.0 x 6.0	No.1 Power source room	10 m
No.2 semi-anechoic chamber	7.5 x 5.8 x 5.2	4.0 x 4.0	-	3 m
No.3 semi-anechoic chamber	12.0 x 8.5 x 5.9	6.8 x 5.75	No.3 Preparation room	3 m
No.3 shielded room	4.0 x 6.0 x 2.7	N/A	-	-
No.4 semi-anechoic chamber	12.0 x 8.5 x 5.9	6.8 x 5.75	No.4 Preparation room	3 m
No.4 shielded room	4.0 x 6.0 x 2.7	N/A	-	-
No.5 semi-anechoic chamber	6.0 x 6.0 x 3.9	6.0 x 6.0	-	-
No.5 measurement room	6.4 x 6.4 x 3.0	6.4 x 6.4	-	-
No.6 shielded room	4.0 x 4.5 x 2.7	4.0 x 4.5	-	-
No.6 measurement room	4.75 x 5.4 x 3.0	4.75 x 4.15	-	-
No.7 shielded room	4.7 x 7.5 x 2.7	4.7 x 7.5	-	-
No.8 measurement room	3.1 x 5.0 x 2.7	3.1 x 5.0	-	-
No.9 measurement room	8.8 x 4.6 x 2.8	2.4 x 2.4	-	-
No.10 shielded room	3.8 x 2.8 x 2.8	3.8 x 2.8	-	-
No.11 measurement room	4.0 x 3.4 x 2.5	N/A	-	-
No.12 measurement room	2.6 x 3.4 x 2.5	N/A	-	-
Large Chamber	16.9 x 22.1 x 10.17	16.9 x 22.1	-	10 m
Small Chamber	5.3 x 6.69 x 3.59	5.3 x 6.69	-	-

\* Size of vertical conducting plane (for Conducted Emission test): 2.0 m x 2.0 m for No.1, No.2, No.3, and No.4 semi-anechoic chambers and No.3 and No.4 shielded rooms.

### 3.6 Test data, RF Exposure, Test instruments, and Test set up

Refer to APPENDIX.



## **SECTION 4: Operation of EUT during testing**

### **4.1 Operating Mode(s)**

<b>Mode</b>	<b>Test Item</b>
Test mode (Tx) - Symbol Pattern 1 - Symbol Pattern 2 - Symbol Pattern 3 - Symbol Pattern 4 - Symbol Pattern 5	Conducted Emission <sup>*1)</sup> Duty cycle, Off Time Requirement <sup>*2)</sup> 20 dB Bandwidth EIRP(Peak) Spurious Emissions <sup>*1)</sup> Frequency Stability
*Power of the EUT was set by the software as follows; Power Setting: 9 Software: Ver214 (Date: 2023.07.10, Storage location: EUT memory)	
*This setting of software is the worst case. Any conditions under the normal use do not exceed the condition of setting. In addition, end users cannot change the settings of the output power of the product.	

\*1) The test was performed with the Symbol Pattern 1 as representative.

Since the Symbol Pattern 1 which has the widest OBW and the highest power was taken as the worst.

\*2) The test data of Symbol Pattern 1 was shown as representative since all symbol patterns was the same logic.

## 4.2 Configuration and peripherals

### Conducted Emission test

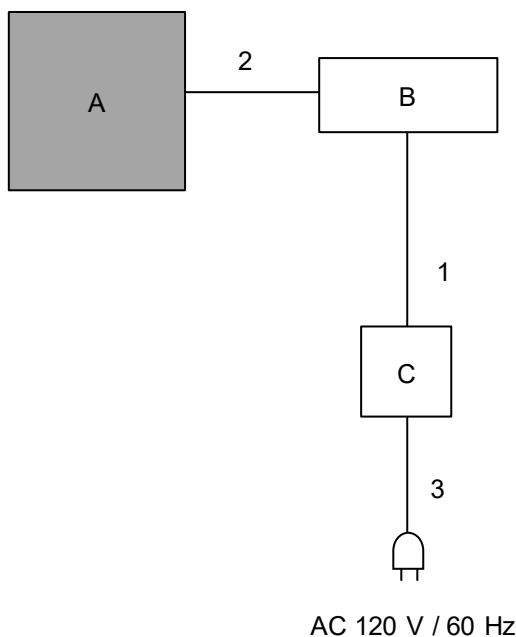

\* Cabling and setup(s) were taken into consideration and test data was taken under worse case conditions.

### Description of EUT and Support equipment

No.	Item	Model number	Serial number	Manufacturer	Remarks
A	Level sensor	FR-SH01	SBH59	Keyence Corporation	EUT
B	Display	FR-SA1C	1	Keyence Corporation	-
C	DC power supply	RPE-4323	824B168G2	RS COMPONENTS LTD	-

### List of cables used

No.	Name	Length (m)	Shield		Remarks
			Cable	Connector	
1	DC & Signal Cable	8.4	Unshielded	Unshielded	-
2	DC & Signal Cable	0.4	Unshielded	Unshielded	-
3	AC Cable	1.9	Unshielded	Unshielded	-

**Radiated Emission tests**

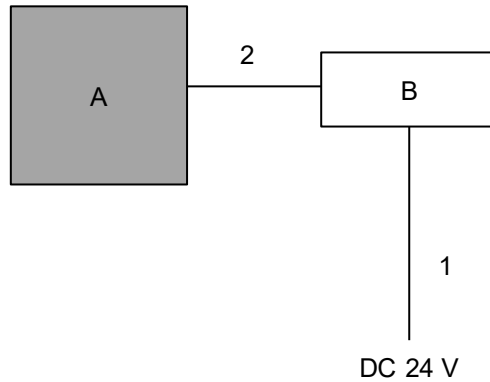

\* Cabling and setup(s) were taken into consideration and test data was taken under worse case conditions.

**Description of EUT and Support equipment**

No.	Item	Model number	Serial number	Manufacturer	Remarks
A	Level sensor	FR-SH01	SBH59	Keyence Corporation	EUT
B	Display	FR-SA1C	1	Keyence Corporation	*1)
	Jig	Power cable	1		*2)

**List of cables used**

No.	Name	Length (m)	Shield		Remarks
			Cable	Connector	
1	DC & Signal Cable	30.0 *1) 2.4 *2)	Unshielded	Unshielded	-
2	DC & Signal Cable	0.4 *1) 0.6 *2)	Unshielded	Unshielded	-

\*1) Used for Spurious Emissions test

\*2) Used for other tests except for Spurious Emissions test

## **SECTION 5: Conducted Emission**

### **Test Procedure and Conditions**

EUT was placed on a urethane platform of nominal size, 1.0 m by 1.5 m, raised 0.8 m above the conducting ground plane.

The rear of tabletop was located 40 cm to the vertical conducting plane. The rear of EUT, including peripherals aligned and flushed with rear of tabletop. All other surfaces of tabletop were at least 80 cm from any other grounded conducting surface. EUT was located 80 cm from a Line Impedance Stabilization Network (LISN) / Artificial mains Network (AMN) and excess AC cable was bundled in center.

For the tests on EUT with other peripherals (as a whole system)

I/O cables that were connected to the peripherals were bundled in center. They were folded back and forth forming a bundle 30 cm to 40 cm long and were hanged at a 40 cm height to the ground plane. All unused 50 ohm connectors of the LISN (AMN) were resistivity terminated in 50 ohm when not connected to the measuring equipment.

The AC Mains Terminal Continuous disturbance Voltage has been measured with the EUT in a Semi Anechoic Chamber.

The EUT was connected to a LISN (AMN).

An overview sweep with peak detection has been performed.

The test results and limit are rounded off to one decimal place, so some differences might be observed.

**Detector** : QP and CISPR AV  
**Measurement Range** : 0.15 MHz to 30 MHz  
**Test Data** : APPENDIX  
**Test Result** : Pass

**Figure 1: Test Setup**

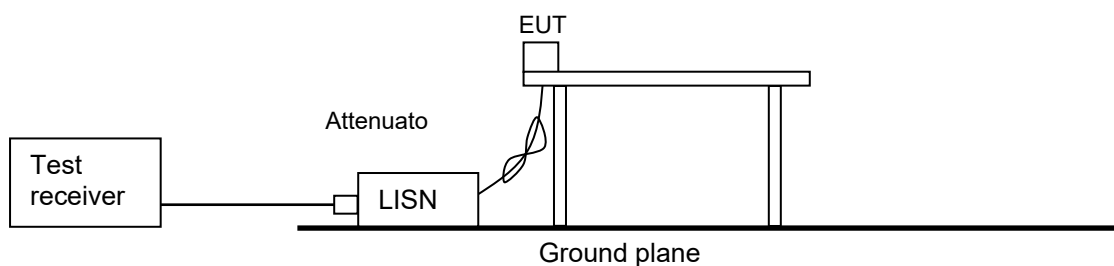

## **SECTION 6: Radiated Emissions**

### **Test Procedure**

#### **[For below 30 MHz]**

The EUT was placed on a urethane platform of nominal size, 1.0 m by 1.5 m, raised 0.8 m above the conducting ground plane.

The Radiated Electric Field Strength has been measured in a Semi Anechoic Chamber with absorbent materials lined on a ground plane.

The loop antenna was fixed height at 1.0 m.

The EUT was rotated a full revolution in order to obtain the maximum value of the electric field intensity.

The measurements were performed for vertical polarization (antenna angle: 0 deg., 45 deg., 90 deg., 135 deg., and 180 deg.) and horizontal polarization.

\*Refer to Figure 1 about Direction of the Loop Antenna.

#### **[For above 30 MHz, up to 1 GHz]**

The EUT was placed on a urethane platform of nominal size, 1.0 m by 1.5 m, raised 0.8 m above the conducting ground plane. The Radiated Electric Field Strength has been measured in a Semi Anechoic Chamber with a ground plane.

The height of the measuring antenna varied between 1 m and 4 m and EUT was rotated a full revolution in order to obtain the maximum value of the electric field strength.

#### **[For above 1 GHz, up to 40 GHz]**

The EUT was placed on a urethane platform of nominal size, 0.5 m by 0.5 m, raised 1.5 m above the conducting ground plane.

The Radiated Electric Field Strength has been measured in a Semi Anechoic Chamber with absorbent materials lined on a ground plane.

The height of the measuring antenna varied between 1 m and 4 m and EUT was rotated a full revolution in order to obtain the maximum value of the electric field strength.

Test antenna was aimed at the EUT for receiving the maximum signal and always kept within the illumination area of the 3 dB beamwidth of the antenna.

The measurements were performed for both vertical and horizontal antenna polarization with the Test Receiver, or the Spectrum Analyzer.

The measurements were made with the following detector function of the test receiver and the Spectrum analyzer.

The test was made with the detector (RBW/VBW) in the following table.

#### **Test Antennas are used as below;**

Frequency	Below 30 MHz	30 MHz to 200 MHz	200 MHz to 1 GHz	Above 1 GHz
Antenna Type	Loop	Biconical	Logperiodic	Horn

Frequency	From 9 kHz to 90 kHz and From 110 kHz to 150 kHz	From 90 kHz to 110 kHz	From 150 kHz to 490 kHz	From 490 kHz to 30 MHz	From 30 MHz to 1 GHz	From 1 GHz to 40 GHz	
Instrument used	Test Receiver					Spectrum Analyzer	
Detector	PK / AV	QP	PK / AV	QP	QP	PK *a)	AV
IF Bandwidth	200 Hz	200 Hz	9 kHz	9 kHz	120 kHz	RBW: 1 MHz VBW: 3 MHz	RBW: 1 MHz VBW: 1 / T

\*a) The Spectrum Analyzer was used in 3 dB resolution bandwidth.

[Test setup]  
 Below 1 GHz

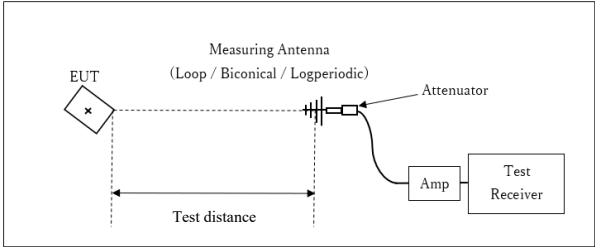

Test Distance: 3 m

× : Center of turn table

1 GHz to 10 GHz

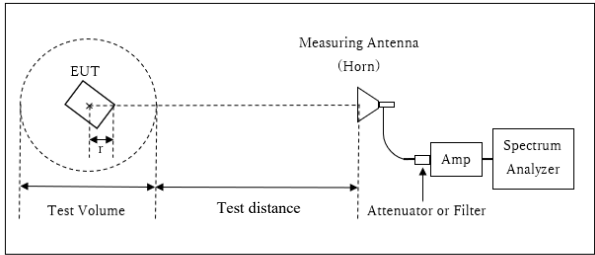

Distance Factor:  $20 \times \log(4.0 \text{ m} / 3.0 \text{ m}) = 2.5 \text{ dB}$   
 \* Test Distance:  $(3 + \text{SVSWR Volume} / 2) - r = 4.0 \text{ m}$

SVSWR Volume : 2.0 m  
 (SVSWR Volume has been calibrated based on CISPR 16-1-4.)  
 $r = 0.0 \text{ m}$

\*The test was performed with  $r = 0.0 \text{ m}$  since EUT is small and it was the rather conservative condition.

r : Radius of an outer periphery of EUT  
 × : Center of turn table

10 GHz to 40 GHz

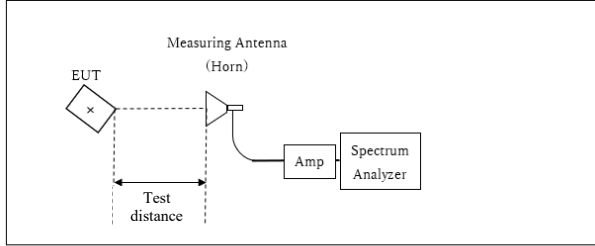

Distance Factor:  $20 \times \log(1.0 \text{ m}^* / 3.0 \text{ m}) = -9.5 \text{ dB}$   
 \*Test Distance: 1 m

× : Center of turn table

Figure 1: Direction of the Loop Antenna

Side View (Vertical)

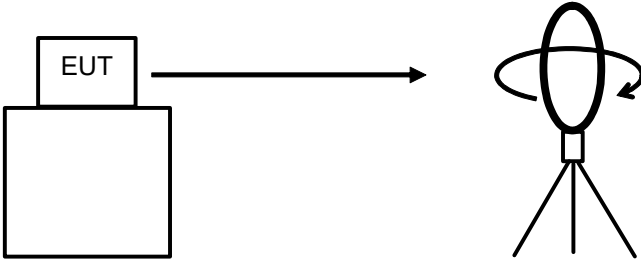

Top View (Horizontal)

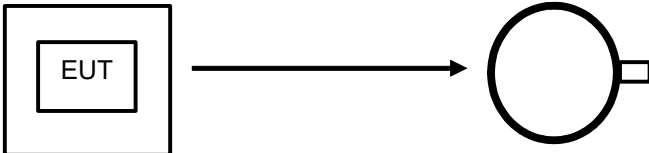

Antenna was not rotated.

Top View (Vertical)

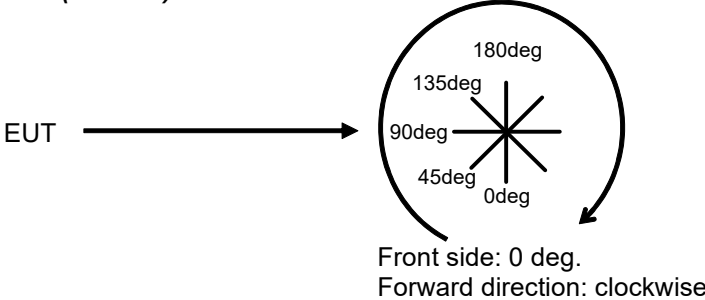

**[Above 40 GHz]**

The test was performed based on “Procedures for testing millimeter-wave systems” of ANSI C63.10-2013.

The EUT was placed on a urethane platform, raised 1.5 m above the conducting ground plane. The measurements were performed on handheld method.

Set spectrum analyzer RBW, VBW, span, etc., to the proper values. Note these values. Enable two traces—one set to “clear write,” and the other set to “max hold.” Begin hand-held measurements with the test antenna (horn) at a distance of 1 m from the EUT in a horizontally polarized position. Slowly adjust its position, entirely covering the plane 1 m from the EUT. Observation of the two active traces on the spectrum analyzer will allow refined horn positioning at the point(s) of maximum field intensity. Repeat with the horn in a vertically polarized position. If the emission cannot be detected at 1 m, reduce the RBW to increase system sensitivity. Note the value. If the emission still cannot be detected, move the horn closer to the EUT, noting the distance at which a measurement is made.

Note the maximum level indicated on the spectrum analyzer. Adjust this level, if necessary, by the antenna gain, filter loss, conversion loss of the external mixer and gain of LNA used, at the frequency under investigation. Calculate the field strength of the emission at the measurement distance from the Friis’ transmission equation.

Frequency	40 GHz to 50 GHz	50 GHz to 75 GHz	75 GHz to 110 GHz	110 GHz to 200 GHz
Final measurement distance with 1 MHz Peak detector	1.0 m	0.75 m	0.5 m	0.01 m

**[Test setup]**  
 40 GHz to 200 GHz

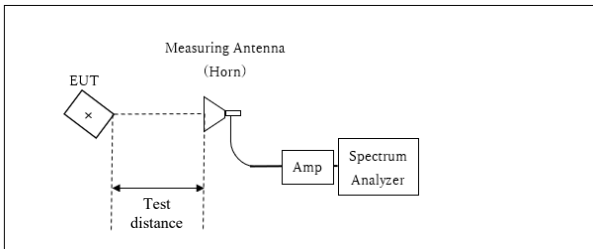

x : Center of turn table

\*Test Distance: Refer to the above table.



**[About fundamental measurement]**

**Test Procedure**

The test was performed based on “Procedures for testing millimeter-wave systems” of ANSI C63.10-2013.

The peak power were measured with an RF detector that has a detection bandwidth that encompasses the 57-71 GHz band and has a video bandwidth of at least 10 MHz.

The carrier levels were measured in the far field. The distance of the far field was calculated from follow equation.

$$r = \frac{2D^2}{\lambda}$$

where

*r* is the distance from the radiating element of the EUT to the edge of the far field, in m  
*D* is the largest dimension of both the radiating element and the test antenna (horn), in m  
*Lambda* is the wavelength of the emission under investigation [300/*f* (MHz)], in m

Frequency [GHz]	Wavelength <i>Lambda</i> [mm]	Maximum Dimention			Far Field Boundary <i>r</i> [m]	Tested Distance [m]
		EUT [m]	Test Antenna [m]	Maximum <i>D</i> [m]		
63	4.8	0.01940	0.03759	0.03759	0.594	0.65

The test was performed based on stages 1-4 following;

Stage 1:

Connect the measurement antenna for the fundamental frequency band to the mm-wave RF detector. Place the measurement antenna at a test distance that is in the far-field of the measurement antenna. Place the measurement antenna in the main beam of the EUT then maximize the fundamental emission. The maximum direction was searched under carefully since beam-widths are extremely narrow. Record the peak voltage from DSO as DSO Reading.

Stage 2:

Disconnect the measurement antenna from the RF input port of the instrumentation system. Connect a mm-wave source to the RF input port of the instrumentation system via a waveguide variable attenuator. The mm-wave source shall be unmodulated. Adjust the frequency of the mm-wave source to the center of the frequency range occupied by the transmitter. Adjust the amplitude of the mm-wave source and/or the variable attenuator such that the DSO indicates a voltage equal to the peak voltage recorded in Stage 1. The output level of mm-wave source at this time is recorded as SG Reading.

Stage 3:

Disconnect the waveguide variable attenuator from the RF input port of the instrumentation system. Without changing any settings, connect the waveguide variable attenuator to a wideband mm-wave power meter with a thermocouple detector or equivalent. Measure the power and record it as PM reading.

Stage 4:

Correct the peak substitution power at the input to the measurement instrument, as recorded in Stage 3, for any external gain and/or attenuation between the measurement antenna and the measurement instrument that was not included in the substitution power measurement.

[Test configuration]

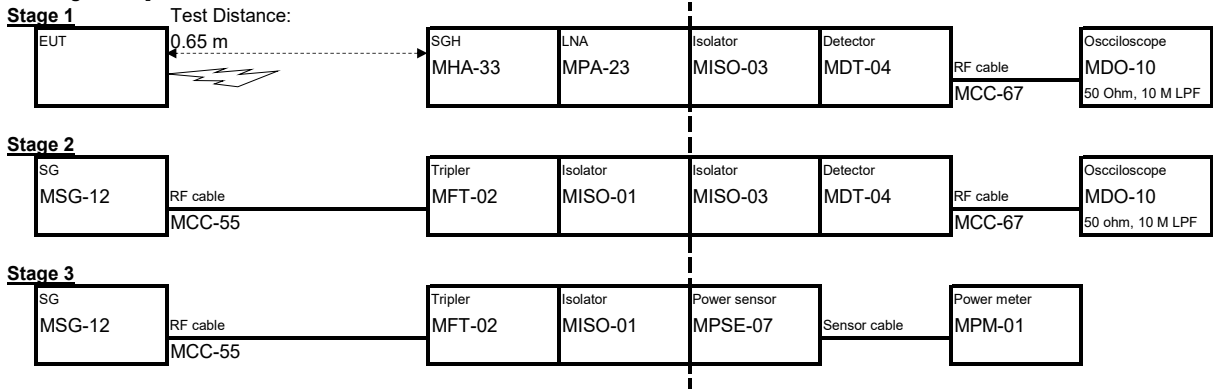

In order to maximize the carrier level, the EUT, which has a horizontally polarized antenna, and the polarization plane of the measurement antenna were aligned for the test.

The test results and limit are rounded off to one decimal place, so some differences might be observed.

Measurement range : 9 kHz to 200 GHz  
 Test data : APPENDIX  
 Test result : Pass

## **SECTION 7: Frequency Stability**

### **Test Procedure**

The block downconverter was placed in side of the temperature chamber's drain hole.

The power supply was set to nominal operating voltage (100 %), and the spectrum mask was measured at 20 deg. C. After that, EUT power supply was varied between 85 % and 115 % of nominal voltage and the frequency excursion of the EUT emission mask was recorded.

The EUT operating temperature was raised to 50 deg. C., and the frequency excursion of the EUT emission mask was recorded. Measurements were repeated at each 10 deg. C. decrement down to -20 deg. C.

In addition, additional tests were performed with some temperatures according to the customer's request.

Both lower and upper frequencies of the -20 dB Bandwidth were recorded.

**Test data** : **APPENDIX**  
**Test result** : **Pass**

**APPENDIX 1: Test data**

**Conducted Emission**

Test place	Ise EMC Lab.
Semi Anechoic Chamber	No. 4
Date	July 24, 2023
Temperature / Humidity	23 deg. C / 54 % RH
Engineer	Sayaka Hara
Mode	Tx Symbol Pattern 1

Limit : FCC\_Part 15 Subpart C(15.207)

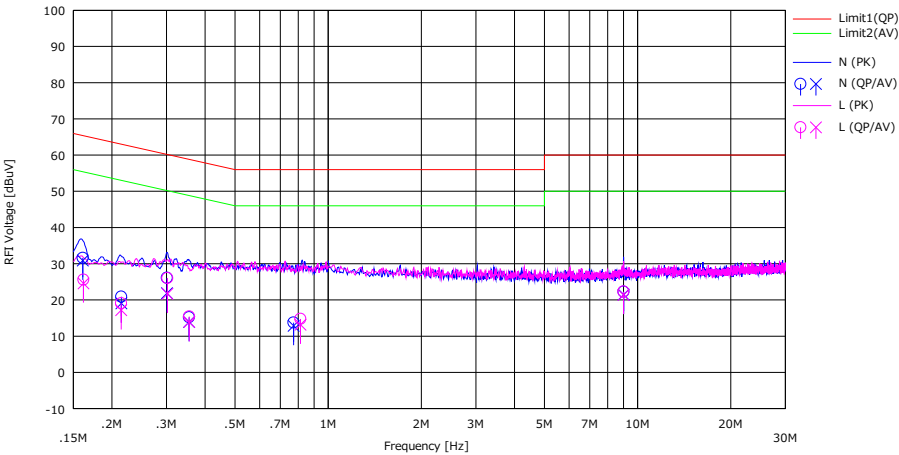

No.	Freq. [MHz]	Reading		USN [dB]	LOSS [dB]	Results		Limit		Margin		Phase	Comment
		(QP) [dBuV]	(AV) [dBuV]			(QP) [dBuV]	(AV) [dBuV]	(QP) [dB]	(AV) [dB]				
1	0.16107	18.40	17.70	0.05	13.13	31.58	30.88	65.41	55.41	33.83	24.53	N	
2	0.21454	7.70	5.90	0.04	13.13	20.87	19.07	63.03	53.03	42.16	33.96	N	
3	0.30115	12.90	8.70	0.04	13.15	26.09	21.89	60.21	50.21	34.12	28.32	N	
4	0.35505	2.00	0.70	0.04	13.16	15.20	13.90	58.84	48.84	43.64	34.94	N	
5	0.77245	0.50	-0.40	0.06	13.19	13.75	12.85	56.00	46.00	42.25	33.15	N	
6	9.01049	8.50	7.70	0.19	13.57	22.26	21.46	60.00	50.00	37.74	28.54	N	
7	0.16188	12.40	11.40	0.05	13.13	25.58	24.58	65.37	55.37	39.79	30.79	L	
8	0.21434	5.90	4.00	0.04	13.13	19.07	17.17	63.04	53.04	43.97	35.87	L	
9	0.30220	12.80	8.50	0.05	13.15	26.00	21.70	60.18	50.18	34.18	28.48	L	
10	0.35570	2.20	0.70	0.05	13.16	15.41	13.91	58.83	48.83	43.42	34.92	L	
11	0.81381	1.50	-0.10	0.06	13.20	14.76	13.16	56.00	46.00	41.24	32.84	L	
12	9.00699	8.50	7.60	0.21	13.57	22.28	21.38	60.00	50.00	37.72	28.62	L	

CHART: WITH FACTOR Peak hold data. CALCULATION : RESULT = READING + C.F (LISN + CABLE + ATT)  
Except for the above table: adequate margin data below the limits.

\*The test result is rounded off to one or two decimal places, so some differences might be observed.

**Duty Cycle, Off Time Requirement**

Test place	Ise EMC Lab.
Semi Anechoic Chamber	No. 4
Date	July 11, 2023
Temperature / Humidity	21 deg. C / 55 % RH
Engineer	Junki Nagatomi
Mode	Tx Symbol Pattern 1

Measured/ Declared	Tx ON+Tx OFF time [ms]	Tx ON Time [ms]	Tx OFF Time [ms]	Duty Result [%]	Duty Factor [dB]
Measured	140.000	2.166	137.834	1.55	-18.11
Declared *	139.998	2.048	137.950	1.46	-18.35

Measured/ Declared	The ratio of Tx OFF Time [%]	Regulation Time [ms]	Tx OFF Time within Regulation Time Limit [ms]	The ratio of Tx OFF Time Limit [%]	Result
Measured	98.45	33.00	25.50	≥ 77.27	Pass
Declared *	98.54	-	-		-

Calculating formula:

$Tx\ OFF\ Time = Tx\ ON + Tx\ OFF\ Time - Tx\ ON\ Time$   
 $Duty = (Tx\ ON\ Time / Tx\ ON + Tx\ OFF\ Time) * 100$   
 $Duty\ factor = 10 * \log (Tx\ ON + Tx\ OFF\ Time / Tx\ ON\ Time)$   
 $The\ ratio\ of\ Tx\ OFF\ Time = (Tx\ OFF\ Time / Tx\ ON + Tx\ OFF\ Time) * 100$

\* See the application document.

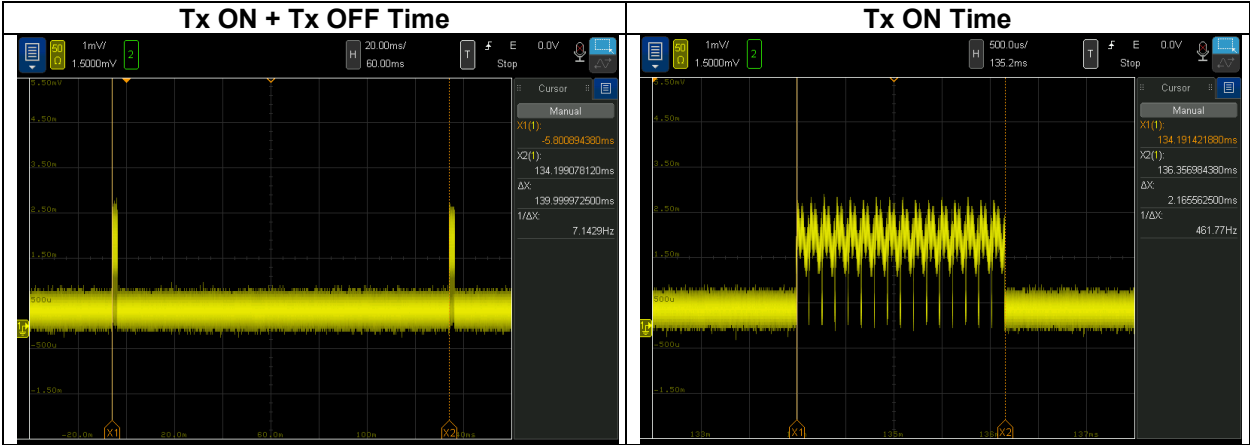

### 20 dB Bandwidth

Test place	Ise EMC Lab.
Semi Anechoic Chamber	No. 4
Date	July 13, 2023
Temperature / Humidity	22 deg. C / 66 % RH
Engineer	Junki Nagatomi
Mode	Tx

Symbol Pattern	Center Frequency [GHz]	Measured -20 dBc Frequency		20 dB bandwidth [MHz]	Lower Limit [GHz]	Upper Limit [GHz]	Result
		Lower Result [GHz]	Upper Result [GHz]				
1	60.5	57.9425	63.0190	5076.5	57	64	Pass
2	60.0	57.9450	62.0150	4070.0			Pass
3	61.0	58.9550	63.0150	4060.0			Pass
4	59.5	57.9430	61.0210	3078.0			Pass
5	60.5	58.9370	62.0210	3084.0			Pass

Calculating formula:

$$20 \text{ dB bandwidth} = (\text{Measured -20 dBc Frequency Upper Result}) - (\text{Measured -20 dBc Frequency Lower Result})$$

[Data]

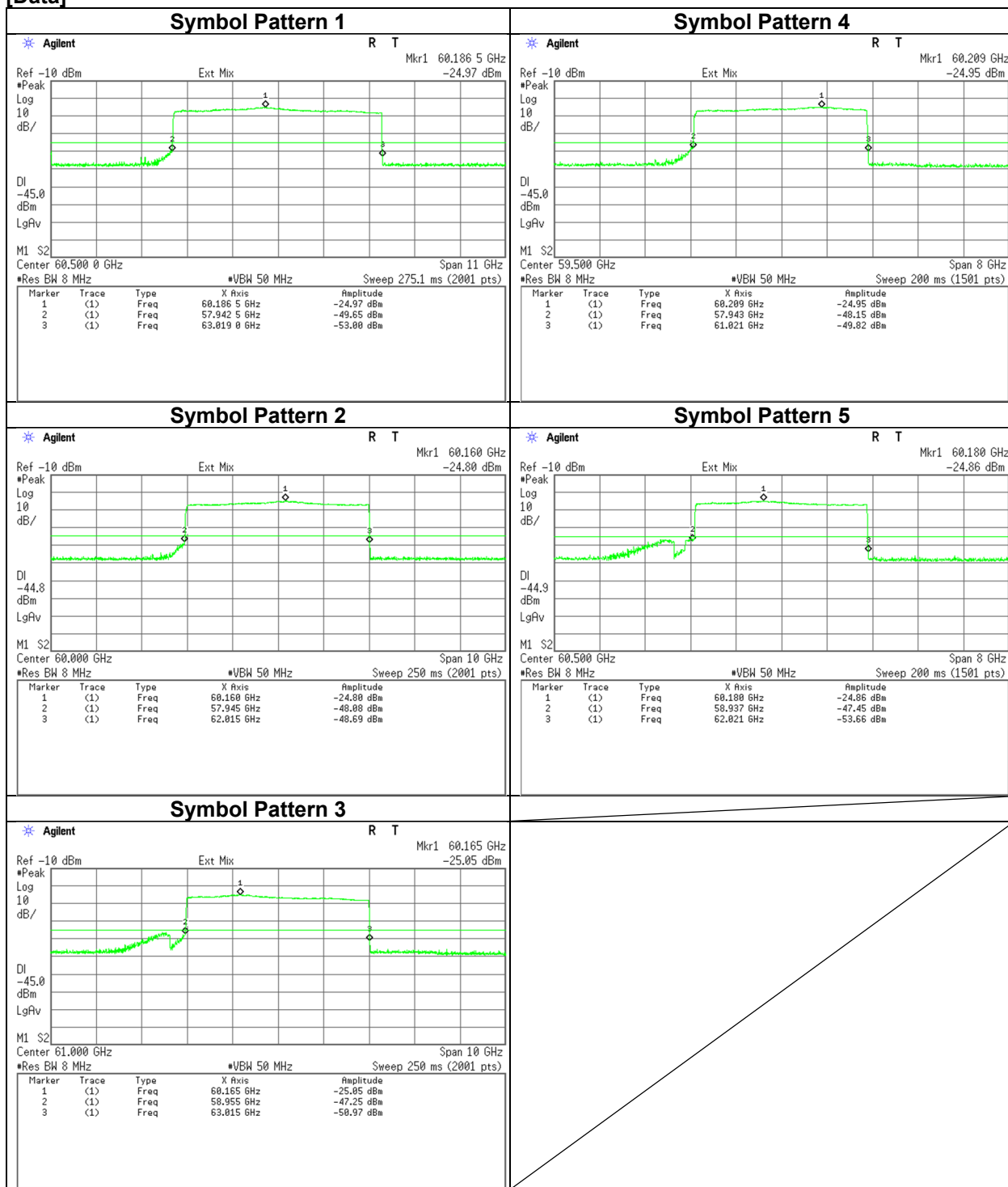

The measurement was performed with Peak detector and Max Hold since the duty cycle was not 100 %.

### EIRP(Peak)

Test place	Ise EMC Lab.	
Semi Anechoic Chamber	No. 4	No. 4
Date	July 11, 2023	July 13, 2023
Temperature / Humidity	21 deg. C / 55 % RH	21 deg. C / 49 % RH
Engineer	Junki Nagatomi	Sayaka Hara
Mode	Tx	

Symbol Pattern	Center Frequency [GHz]	Stage 1	Stage 2	Stage 3	Stage 4	Tested Distance [m]	FSL [dB]	EIRP (Peak)				Margin [dB]	
		DSO Reading (Peak) [mV]	S/G Setting Power [dBm]	P/M Reading [dBm]	LNA Gain [dB]			Rx Ant. Gain [dBi]	Result		Limit		
1	60.50	2.91	9.31	-11.95	25.20	23.74	0.65	64.34	3.45	2.22	14	25.12	10.55
2	60.00	2.91	9.30	-12.20	25.37	23.67	0.65	64.26	3.03	2.01	14	25.12	10.97
3	61.00	2.77	9.59	-13.01	25.03	23.80	0.65	64.41	2.57	1.81	14	25.12	11.43
4	59.50	2.91	9.43	-12.09	25.45	23.70	0.65	64.19	2.96	1.98	14	25.12	11.04
5	60.50	2.77	9.21	-12.58	25.20	23.74	0.65	64.34	2.82	1.92	14	25.12	11.18

Calculating formula:

FSL (Free Space path Loss) =  $10 * \log_{10}((4 * \pi * \text{Tested Distance} / \text{Lambda})^2)$

EIRP (Peak) = P/M Reading - Rx Ant. Gain - LNA Gain + FSL

These calculation results are same as results which were calculated with formulas described in the Section 9 of ANSI C63.10-2013.



[Data]

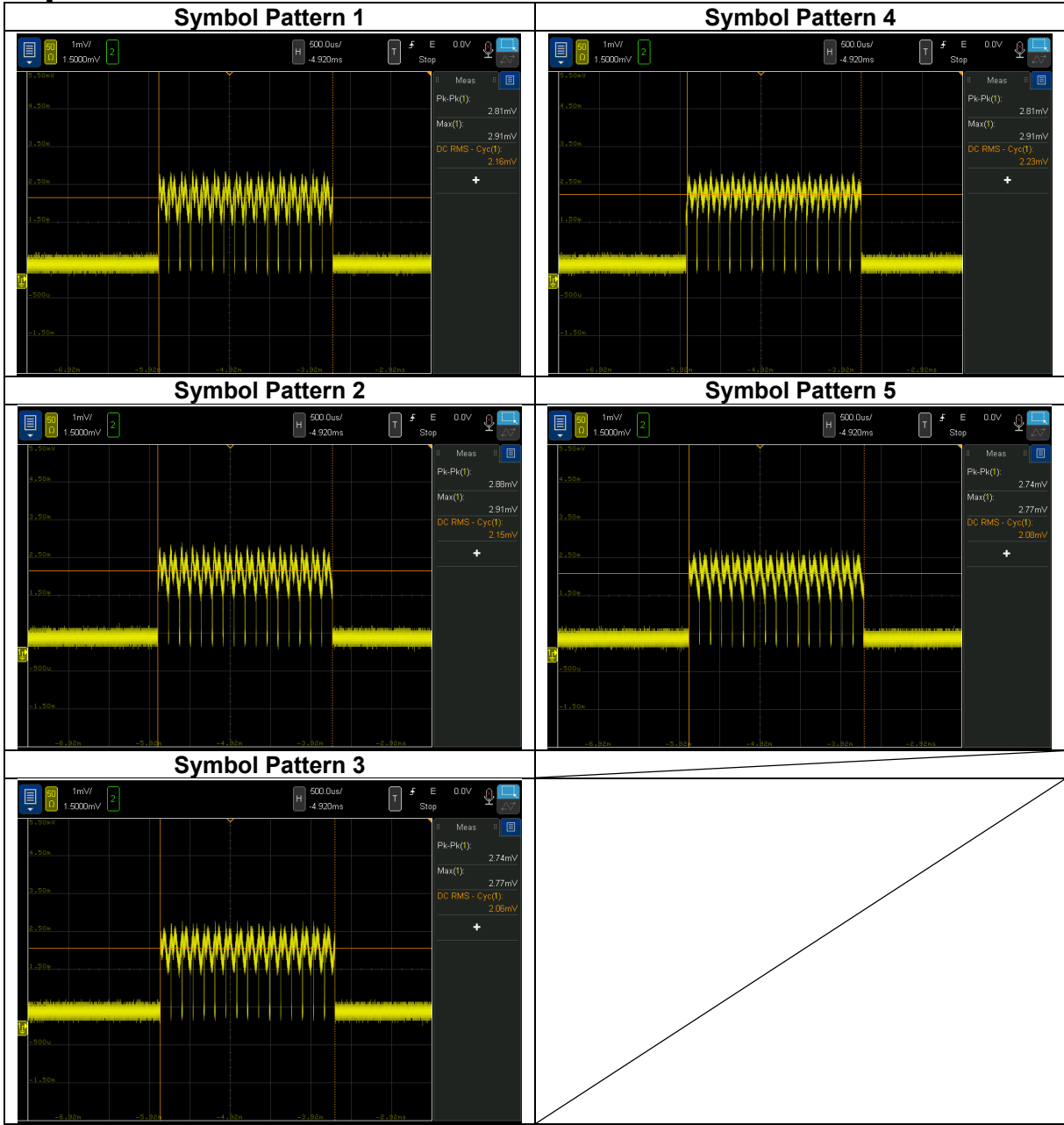

## Spurious Emissions (Below 40 GHz)

Test place	Ise EMC Lab.					
Semi Anechoic Chamber	No. 3	No. 4	No. 3	No. 4	No. 4	No. 4
Date	July 10, 2023	July 27, 2023	July 13, 2023	July 18, 2023	July 18, 2023	July 19, 2023
Temperature / Humidity	24 deg. C / 49 % RH	24 deg. C / 48 % RH	23 deg. C / 56 % RH	23 deg. C / 42 % RH	23 deg. C / 42 % RH	22 deg. C / 54 % RH
Engineer	Sayaka Hara	Sayaka Hara	Junki Nagatomi	Junki Nagatomi	Sayaka Hara	Yuichiro Yamazaki
	(9 kHz to 30 MHz)	(26.5 GHz to 40 GHz)	(30 MHz to 1000 MHz)	(18 GHz to 26.5 GHz)	(10 GHz to 18 GHz)	(1 GHz to 10 GHz)
Mode	Tx Symbol Pattern 1					

Polarity	Frequency	Reading (QP / PK)	Reading (AV)	Ant. Factor	Loss	Gain	Result (QP / PK)	Result (AV)	Limit (QP / PK)	Limit (AV)	Margin (QP / PK)	Margin (AV)	Remark
[Hori/Vert]	[MHz]	[dBuV]	[dBuV]	[dB/m]	[dB]	[dB]	[dBuV/m]	[dBuV/m]	[dBuV/m]	[dBuV/m]	[dB]	[dB]	
Hori.	56.5	23.1	-	8.9	7.5	32.2	7.4	-	40.0	-	32.6	-	
Hori.	73.8	28.2	-	6.4	7.8	32.1	10.2	-	40.0	-	29.8	-	
Hori.	97.6	22.3	-	9.9	8.1	32.1	8.1	-	43.5	-	35.4	-	
Hori.	173.8	28.1	-	15.9	8.9	32.1	20.8	-	43.5	-	22.7	-	
Hori.	416.0	34.7	-	16.2	10.9	32.0	29.8	-	46.0	-	16.3	-	
Hori.	543.8	29.9	-	17.8	11.7	32.0	27.4	-	46.0	-	18.7	-	
Vert.	56.5	34.1	-	8.9	7.5	32.2	18.4	-	40.0	-	21.6	-	
Vert.	73.8	32.6	-	6.4	7.8	32.1	14.7	-	40.0	-	25.4	-	
Vert.	97.6	32.2	-	9.9	8.1	32.1	18.0	-	43.5	-	25.5	-	
Vert.	173.8	30.3	-	15.9	8.9	32.1	23.0	-	43.5	-	20.5	-	
Vert.	416.0	35.9	-	16.2	10.9	32.0	31.0	-	46.0	-	15.0	-	
Vert.	543.8	29.5	-	17.8	11.7	32.0	27.1	-	46.0	-	19.0	-	

Result = Reading + Ant Factor + Loss (Cable+Attenuator+Filter+Distance factor(above 1 GHz)) - Gain(Amplifier)

\*Other frequency noises omitted in this report were not seen or had enough margin (more than 20 dB).

\*QP detector was used up to 1GHz.

Distance factor:      1 GHz - 10 GHz       $20\log(4.0\text{ m} / 3.0\text{ m}) = 2.5\text{ dB}$   
                              10 GHz - 40 GHz       $20\log(1.0\text{ m} / 3.0\text{ m}) = -9.5\text{ dB}$

**Spurious Emissions**  
 (Below 40 GHz)  
 (Plot data, Worst case)

Test place	Ise EMC Lab.					
Semi Anechoic Chamber	No. 3	No. 4	No. 3	No. 4	No. 4	No. 4
Date	July 10, 2023	July 27, 2023	July 13, 2023	July 18, 2023	July 18, 2023	July 19, 2023
Temperature / Humidity	24 deg. C / 49 % RH	24 deg. C / 48 % RH	23 deg. C / 56 % RH	23 deg. C / 42 % RH	23 deg. C / 42 % RH	22 deg. C / 54 % RH
Engineer	Sayaka Hara	Sayaka Hara	Junki Nagatomi	Junki Nagatomi	Sayaka Hara	Yuichiro Yamazaki
	(9 kHz to 30 MHz)	(26.5 GHz to 40 GHz)	(30 MHz to 1000 MHz)	(18 GHz to 26.5 GHz)	(10 GHz to 18 GHz)	(1 GHz to 10 GHz)
Mode	Tx Symbol Pattern 1					

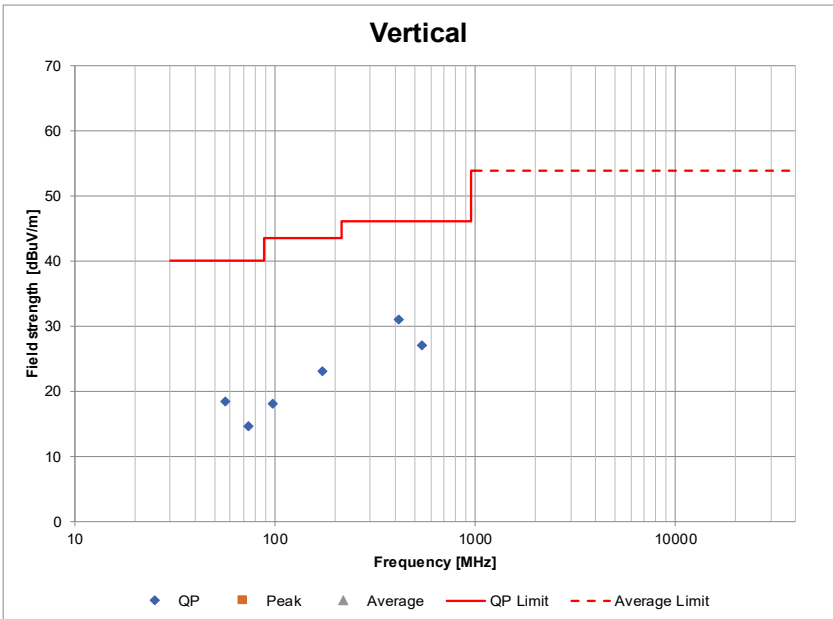
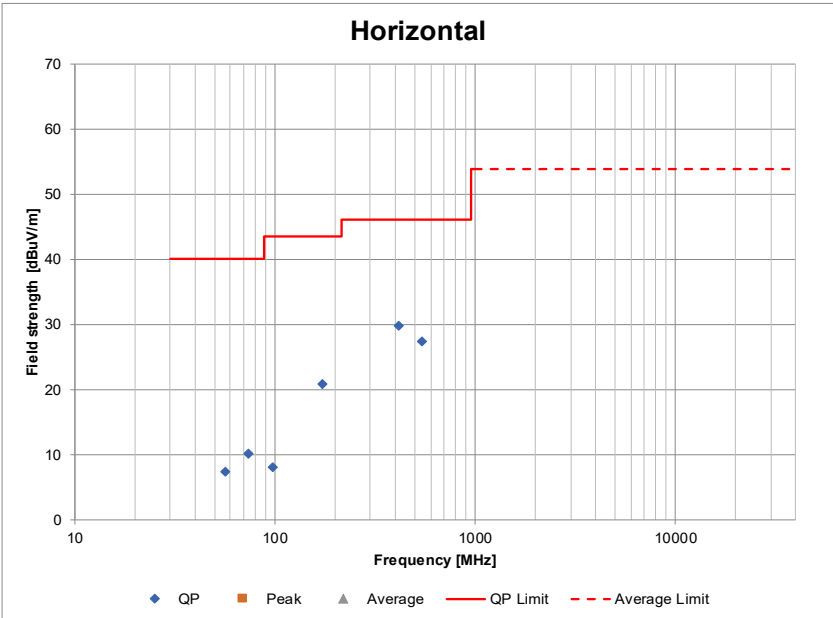

## Spurious Emissions (Above 40 GHz)

Test place	Ise EMC Lab.			
Semi Anechoic Chamber	No. 4	No. 4	No. 4	No. 4
Date	July 14, 2023	July 18, 2023	July 18, 2023	July 19, 2023
Temperature / Humidity	20 deg. C / 50 % RH	23 deg. C / 42 % RH	23 deg. C / 42 % RH	23 deg. C / 64 % RH
Engineer	Sayaka Hara	Junki Nagatomi	Sayaka Hara	Sayaka Hara
	(110 GHz to 170 GHz)	(40 GHz to 50 GHz)	(50 GHz to 110 GHz)	(170 GHz to 200 GHz)
Mode	Tx Symbol Pattern 1			

Freq. [GHz]	Reading (Peak) [dBm]	Rx Ant. Gain [dBi]	Filter Loss [dB]	LNA Gain [dB]	Mixer Conv. Loss [dB]	IF Amp. Gain [dB]	IF Cable Loss [dB]	Test Distance D [m]	FSL [dB]	EIRP		Power density Result at 3 m (Peak) [pW/cm <sup>2</sup> ]	Limit Average [pW/cm <sup>2</sup> ]	Margin Average [dB]	Remarks
										[dBm]	[mW]				
44.346	-54.64	21.69	0.00	31.72	0.00	0.00	7.98	1.00	65.38	-34.69	0.000340	0.30	90	24.76	NS
49.891	-54.48	22.60	0.00	31.85	0.00	0.00	8.61	1.00	66.40	-33.91	0.000406	0.36	90	23.99	NS
53.528	-67.57	22.94	0.00	26.47	45.91	32.04	0.11	0.75	64.51	-38.49	0.000142	0.13	90	28.56	NS
72.803	-68.36	24.34	0.00	20.99	49.23	32.04	0.11	0.75	67.19	-29.20	0.001202	1.06	90	19.28	NS
79.091	-57.87	23.26	0.43	36.80	40.32	32.04	0.11	0.50	64.38	-44.72	0.000034	0.03	90	34.80	NS
86.091	-60.17	23.73	0.47	30.51	41.50	32.04	0.11	0.50	65.12	-39.25	0.000119	0.11	90	29.33	NS
94.939	-56.37	24.26	0.31	33.69	42.90	32.04	0.11	0.50	66.97	-37.07	0.000196	0.17	90	27.15	NS
101.726	-56.14	24.50	0.35	32.48	43.77	32.04	0.11	0.50	66.57	-34.36	0.000367	0.32	90	24.44	NS
108.455	-56.84	24.79	0.99	22.13	44.10	32.04	0.11	0.50	67.13	-23.47	0.004496	3.98	90	13.55	NS
117.946	-82.23	22.57	0.00	18.65	56.30	0.00	0.00	0.01	33.88	-33.28	0.000470	0.42	90	23.35	NS
120.660	-84.36	22.66	0.00	19.11	51.67	0.00	0.00	0.01	34.07	-40.38	0.000092	0.08	90	30.46	NS
121.133	-83.01	22.68	0.00	19.34	51.26	0.00	0.00	0.01	34.11	-39.66	0.000108	0.10	90	29.74	NS
129.133	-83.74	22.92	0.00	20.55	52.15	0.00	0.00	0.01	34.66	-40.39	0.000091	0.08	90	30.47	NS
131.260	-83.69	22.98	0.00	20.08	53.32	0.00	0.00	0.01	34.80	-38.62	0.000137	0.12	90	28.70	NS
142.103	-84.70	23.22	0.00	18.73	53.72	0.00	0.00	0.01	35.49	-37.43	0.000181	0.16	90	27.51	NS
149.607	-86.21	23.32	0.00	18.17	57.26	0.00	0.00	0.01	35.94	-34.50	0.000355	0.31	90	24.58	NS
157.647	-86.21	23.38	0.00	16.97	58.26	0.00	0.00	0.01	36.40	-31.90	0.000645	0.57	90	21.98	NS
163.966	-87.15	23.40	0.00	14.32	60.51	0.00	0.00	0.01	36.74	-27.63	0.001727	1.53	90	17.70	NS
175.137	-85.45	22.52	0.00	0.00	57.72	0.00	0.00	0.01	37.31	-12.94	0.050773	44.89	90	3.02	NS
178.011	-86.55	22.59	0.00	0.00	55.98	0.00	0.00	0.01	37.45	-15.71	0.026839	23.73	90	5.79	NS
192.362	-86.36	22.89	0.00	0.00	56.45	0.00	0.00	0.01	38.12	-14.67	0.034105	30.16	90	4.75	NS
197.409	-86.74	22.98	0.00	0.00	56.50	0.00	0.00	0.01	38.35	-14.87	0.032592	28.82	90	4.95	NS

Calculation:

$$FSL \text{ (Free Space path Loss)} = 10 * \log ((4 * \pi * D / \lambda)^2)$$

$$EIRP = \text{Reading} - \text{Rx Ant. gain} + \text{Filter loss} - \text{LNA gain} + \text{Mixer conversion loss} - \text{IF Amp. gain} + \text{IF Cable loss} + \text{FSL}$$

$$\text{Power density Result at 3 m} = EIRP / (4 * \pi * 300^2)$$

These calculation results are same as results which were calculated with formulas described in the Section 9 of ANSI C63.10-2013.

- The equipment were not used for factor 0 dB of the data sheets.
- The IF Cable loss is included in Mixer loss, so the factor of data sheet were 0 dB.

\*1)

NS: No signal detected.

### [Plot data, Worst case]

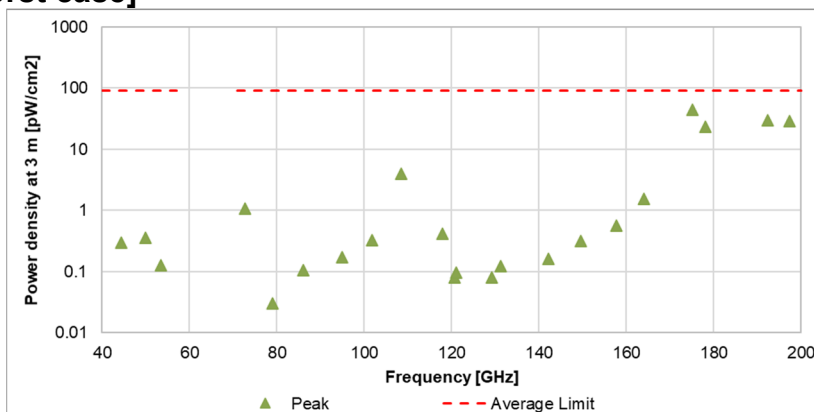

\*The peak result is less than the average limit.