



TEST REPORT

Date of Issue: 2021-12-16

Name and Address of the Client: KEYENCE CORPORATION
1-3-14 Higashinakajima, Higashiyodogawa-ku, Osaka-shi, Osaka-fu
533-8555, Japan

Product Name: RFID Unit

Model: DX-RH1GA

Serial No.: 1X0M000054, 1X0M000066

FCC ID: RF41539D

ISED Certification Number: 5798A-1539D

Sample No.: 1

Sample Condition: Good

Date of Sample Receipt: 2021-10-28

Test Specification: Full items with following standard(s)
 Limited items with following standard(s)
 Requested items by client

FCC Part 15 Subpart C
RSS-247 Issue 2, RSS-Gen Issue 5

Test Result: Refer to "2. Summary of Test Results"

Period of Testing: 2021-10-28 to 2021-11-30

Test Personnel:  EMC Section
(Junya Takashiba)

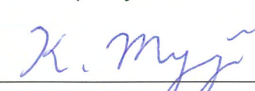
Checked by:  EMC Section
(Keisuke Miyaji) iNARTE : EMC-003627-NE

Approved by:  iNARTE : EMC-002846-NE
(Yasuhiro Kawahara)

 Cosmos Corporation
718-1 Katsurase-cho, Matsusaka-shi, Mie 515-1104, JAPAN

Note:

- 1.This test report should not be reproduced except in full, without the written approval of Cosmos Corporation.
- 2.The test result of this test report is based on the tests made for sample provided, and it is not applicable to individual product identical to the sample or similar product.
- 3.The results of this test report validates the test item only specified in "2. Summary of Test Results".
- 4.This test results in this test report are traceable to the national or international standards.
- 5.The opinions and the interpretations to the result of the description in this report are outside scope where Cosmos Corp. been accredited.
- 6.This Test Report is issued by private test house (Cosmos Corporation), therefore this test report must not be used by the client to claim product certification, approval, or endorsement by A2LA or US government

Contents

Page

1. Description of the Tested Sample.....	3
1.1 Product Description.....	3
1.2 Antenna Description.....	3
1.3 EUT Description.....	4
2. Summary of Test Results	5
3. Test Condition	6
3.1 Mode of Operation	6
3.2 Additional Equipment	6
3.3 Configuration.....	7
3.4 EUT Angle.....	9
4. General Information.....	10
4.1 Test Methodology.....	10
4.2 Test Facility.....	10
4.3 Traceability.....	10
5. Test Result	11
5.1 AC Power Line Conducted Emission.....	11
5.2 Transmitter Spurious Emission (Radiated)	18
5.3 20 dB Bandwidth	32
5.4 Carrier Frequency Separation	35
5.5 Average time of Occupancy	37
5.6 Number of Hopping Frequency	39
5.7 Maximum Peak Conducted Output Power and E.I.R.P.....	40
5.8 Conducted Spurious Emission	43
5.9 Band Edge Measurement.....	50
5.10 Occupied Bandwidth (RSS-Gen Annex A).....	53
6. List of Test and Measurement Instruments.....	56
7. Appendix	59

1. Description of the Tested Sample

1.1 Product Description

Product	RFID Unit
Model (referred to as the EUT)	DX-RH1GA
Manufacturer	KEYENCE CORPORATION
Hardware Version	CS1
Software Version	2.6.1
Type of the Equipment	<input type="checkbox"/> Stand-alone <input checked="" type="checkbox"/> Combined Equipment <input type="checkbox"/> Plug-in Radio Device <input type="checkbox"/> Other
Transmitter Type	<input type="checkbox"/> WLAN <input type="checkbox"/> Bluetooth <input type="checkbox"/> ZigBee <input checked="" type="checkbox"/> RFID (ISO18000-63) <input type="checkbox"/> Other
Antenna Type	<input checked="" type="checkbox"/> Integral Antenna <input type="checkbox"/> Dedicated External Antenna
Number of Antenna	1 Antenna
Operating Frequency Range	902.75 MHz to 927.25 MHz
Type of Modulation	<input checked="" type="checkbox"/> FHSS (ASK) <input type="checkbox"/> Other than FHSS
Type of Power Source	<input type="checkbox"/> AC Mains <input type="checkbox"/> Dedicated AC Adaptor <input type="checkbox"/> DC Voltage <input checked="" type="checkbox"/> Battery
Input Power Rating	DC 3.6 V
Type of Battery (if applicable)	Li-ion Battery
Thermal Limitation	-20 °C to 50 °C

1.2 Antenna Description

Model	Gain	Antenna Type
KSA-926A6015F100B	2.97 dBi	Quadrifilar Helix Antenna

1.3 EUT Description

Equipment under test is as follow:

Instrument	Model	Serial No.
RFID Unit (EUT A) *1	DX-RH1GA	1X0M000054
RFID Unit (EUT B) *2	DX-RH1GA	1X0M000066

Note:

*1: This equipment was used during the following tests;

20 dB Bandwidth, Carrier Frequency Separation, Number of Hopping Frequency,
Average Time of Occupancy, Maximum Peak Conducted Output Power and E.I.R.P.,
Conducted Spurious Emission, Band Edge Measurement and Occupied Bandwidth.

*2: This equipment was used during the following tests;

AC Power Line Conducted Emission and Transmitter Spurious Emissions (Radiated).

2. Summary of Test Results

These test results are the test results of the condition specified with “3. Test Condition”.

FCC Section	ISED Section	Test Item	FCC Result	ISED Result
15.207	RSS-Gen, 8.8	AC Power Line Conducted Emission	Passed	Passed
15.209	RSS-Gen, 8.9	Transmitter Spurious Emission (Radiated)	Passed	Passed
15.215(c)	RSS-247, 5.1	20 dB Bandwidth	Passed	Passed
15.247(a)	RSS-247, 5.1	Carrier Frequency Separation	Passed	Passed
15.247(a)	RSS-247, 5.1	Number of Hopping Frequency	Passed	Passed
15.247(a)	RSS-247, 5.1	Average Time of Occupancy	Passed	Passed
15.247(b)	RSS-247, 5.4	Maximum Peak Conducted Output Power and E.I.R.P.	Passed	Passed
15.247(d)	RSS-247, 5.5	Conducted Spurious Emission	Passed	Passed
15.247(d)	---	Band Edge Measurement	Passed	---
---	RSS-Gen, Annex A	Occupied Bandwidth	---	Passed
---	RSS-Gen, 7.3	Receiver Spurious Emission (Radiated)	---	N/A *

Note:

*: This item does not apply because it is required only for stand-alone receiver operating in the 30 MHz to 960 MHz and scanner receiver.

3. Test Condition

3.1 Mode of Operation

Mode A : RFID

Note:

The EUT makes communication emission with the maximum RF power by a special test program.
Setting: RF Output: 30 dBm

The EUT makes communication emission with the maximum RF power by a special test settings.

3.2 Additional Equipment

The equipment was tested together with additional peripherals.
The following peripherals were used during the tests:

Instrument	Model	Serial No.	Manufacturer
PDA	DX-W600	---	KEYENCE CORPORATION
AC Adapter	OP-88389	H0000416	KEYENCE CORPORATION
Communication Cradle	DX-UC1UL	1111100102	KEYENCE CORPORATION
Battery Pack	DX-BC6	H77000939 202043	KEYENCE CORPORATION

3.3 Configuration

	Equipment	Model	Cable	Length	Shield	
A	EUT A	DX-RH1GA (S/N: 1X0M000054)	a	AC Power Cord	2.0 m	×
			b	DC Power Cord	0.9 m	×
B	EUT B	DX-RH1GA (S/N: 1X0M000066)				
C	PDA	DX-W600				
D	AC Adapter	OP-88389 (S/N: H0000416)				
E	Communication Cradle	DX-UC1UL (S/N: 1111100102)				
F	Battery Pack	DX-BC6 (S/N: H77000939 202043)				

20 dB Bandwidth / Carrier Frequency Separation / Number of Hopping Frequency /
 Average Time of Occupancy / Maximum Peak Conducted Output Power and E.I.R.P. /
 Conducted Spurious Emission / Band Edge Measurement / Occupied Bandwidth

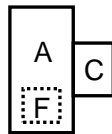

Maximum Peak Conducted Output Power and E.I.R.P.

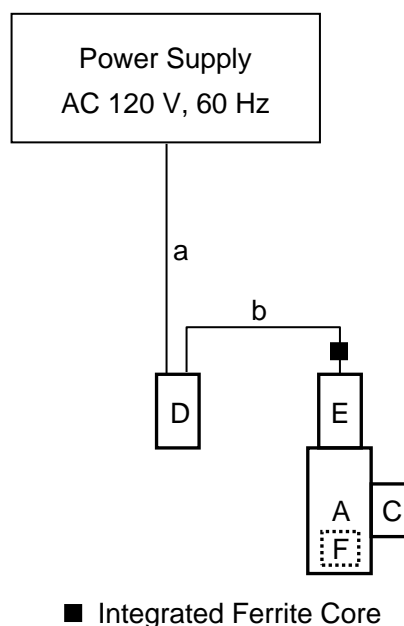

3.3 Configuration (Continued)

AC Power Line Conducted Emission

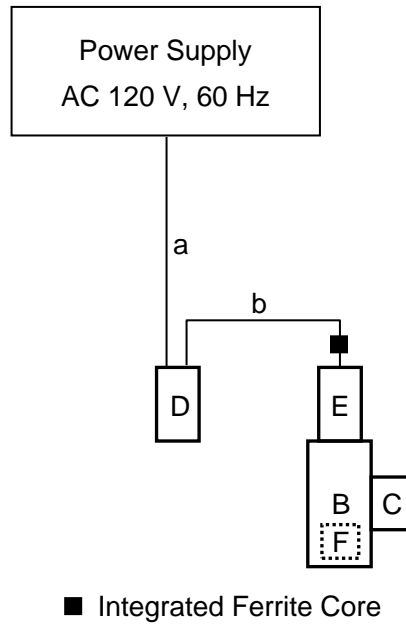

Transmitter Spurious Emission (Radiated)

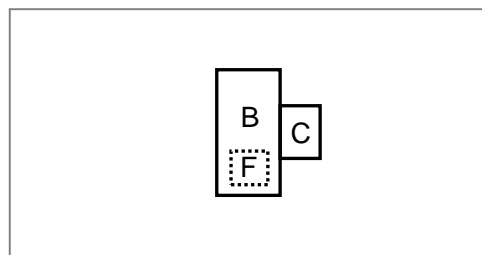

Non-conductive table, 0.8 m high (Below 1 GHz)
Non-conductive table, 1.5 m high (Above 1 GHz)

3.4 EUT Angle

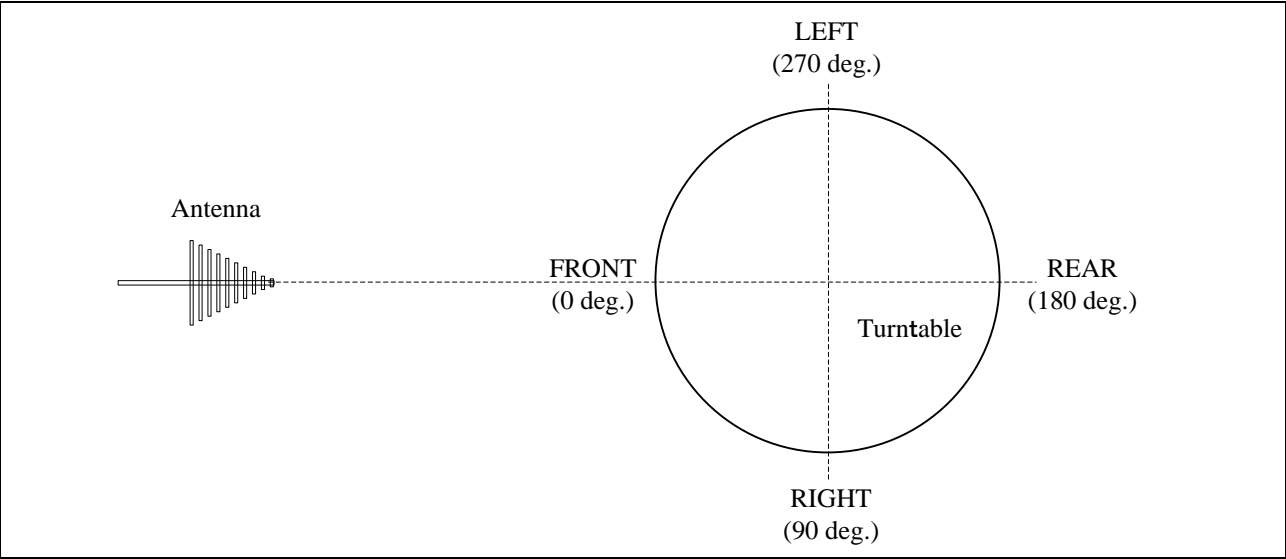

4. General Information

4.1 Test Methodology

All measurement subject to the present test report is carried out according to the procedures in ANSI C63.10-2013.

4.2 Test Facility

The measurement was carried out at the following facility.

Cosmos Corporation EMC Lab. Oonoki
3571-2 Oonoki, Watarai-cho, Watarai-gun, Mie 516-2102, Japan

- Semi anechoic Chamber 3 m (COAC3M-01)
- Shielded Room (COSR-01)
- Measurement Room

Cosmos Corporation EMC Lab. Oonoki is accredited in accordance with the International Standard ISO/IEC 17025 by the following accreditation bodies and the test facility is registered by the following bodies.

Accreditation: FCC Designation No. JP5182

Recognition: ISED Canada CAB ID. JP0007

4.3 Traceability

The calibration of measurement equipment used in the test subject to the present report is designed and operated to ensure that the measurement is traceable to national standards of measurement or equivalent abroad.

5. Test Result

5.1 AC Power Line Conducted Emission

5.1.1 Setting Remarks

The conducted disturbance voltage of AC power line in the frequency range from 150 kHz to 30 MHz was measured in accordance with ANSI C63.4 clause 7.

The non-conductive table, 0.8 m high, was placed on the reference ground plane, and the EUT was put on the non-conductive table.

The used Line Impedance Stabilizing Network (LISN) has a rated impedance of 50 Ω /50 μ H as specified in CISPR16-1-2.

The test receiver with Quasi Peak and Average detector is in accordance with CISPR 16-1-1.

The conducted emission level is calculated by adding Cable Attenuation Factor and Insertion Loss of LISN.

Setting Condition of Test Receiver

Frequency range	Detector	RBW
150 kHz to 30 MHz	Quasi-peak	9 kHz
	Average	9 kHz

5.1.2 Limit

Frequency range	Conducted Limit [dB μ V]	
	Quasi-Peak	Average
150 kHz to 500 kHz	66 to 56 *	56 to 46 *
500 kHz to 5 MHz	56	46
5 MHz to 30 MHz	60	50

5.1.3 Test Detail

Result: Passed

Uncertainty of measurement result : ± 1.39 dB
 Test operator : Junya Takashiba
 Date of testing : 2021-11-19
 Room temperature : 28 $^{\circ}$ C
 Relative humidity : 44 %

Note:

*: Decrease with the logarithm of the frequency.

5.1.3 Test Detail (Continued)

Worst Test Data (Tx 1ch)

***** Cosmos Corporation *****
 <<Conducted Emission -EP5/CE Ver 5.4.40->>

19 November, 2021 17:45
 163429E CE Total01.dat

Limit : FCC15.207, RSS-Gen
 Model : DX-RH1GA
 S/N : 1XOM000066
 Operator : J. Takashiba
 Power : DC 3.7V
 Environment : 28°C, 44%
 Mode : RFID 1ch
 Remark1 : AC Adapter:AC 120V, 60Hz
 Remark2 :
 Remark3 : RBW : 9kHz (150kHz - 30MHz)

 Final Result

--- L1 Phase ---

No.	Frequency [MHz]	Reading		c. f [dB]	Result		Limit		Margin	
		QP [dB(μV)]	AV [dB(μV)]		QP [dB(μV)]	AV [dB(μV)]	QP [dB(μV)]	AV [dB(μV)]	QP [dB]	AV [dB]
1	0.15034	30.7	20.5	10.2	40.9	30.7	66.0	56.0	25.1	25.3
2	0.48645	26.9	19.1	10.0	36.9	29.1	56.2	46.2	19.3	17.1
3	0.98387	15.1	9.2	10.0	25.1	19.2	56.0	46.0	30.9	26.8
4	4.18732	13.4	7.1	10.2	23.6	17.3	56.0	46.0	32.4	28.7
5	8.3024	18.1	11.5	10.2	28.3	21.7	60.0	50.0	31.7	28.3
6	12.1742	22.1	17.5	10.3	32.4	27.8	60.0	50.0	27.6	22.2

--- L2 Phase ---

No.	Frequency [MHz]	Reading		c. f [dB]	Result		Limit		Margin	
		QP [dB(μV)]	AV [dB(μV)]		QP [dB(μV)]	AV [dB(μV)]	QP [dB]	AV [dB]		
1	0.15025	30.4	19.9	10.3	40.7	30.2	66.0	56.0	25.3	25.8
2	0.4854	27.1	19.3	10.0	37.1	29.3	56.2	46.2	19.1	16.9
3	0.8254	15.1	6.4	10.0	25.1	16.4	56.0	46.0	30.9	29.6
4	2.83854	13.6	6.5	10.1	23.7	16.6	56.0	46.0	32.3	29.4
5	7.78103	18.2	11.4	10.2	28.4	21.6	60.0	50.0	31.6	28.4
6	12.98324	23.1	18.2	10.4	33.5	28.6	60.0	50.0	26.5	21.4

5.1.3 Test Detail (Continued)

Worst Test Data (Tx 1ch)

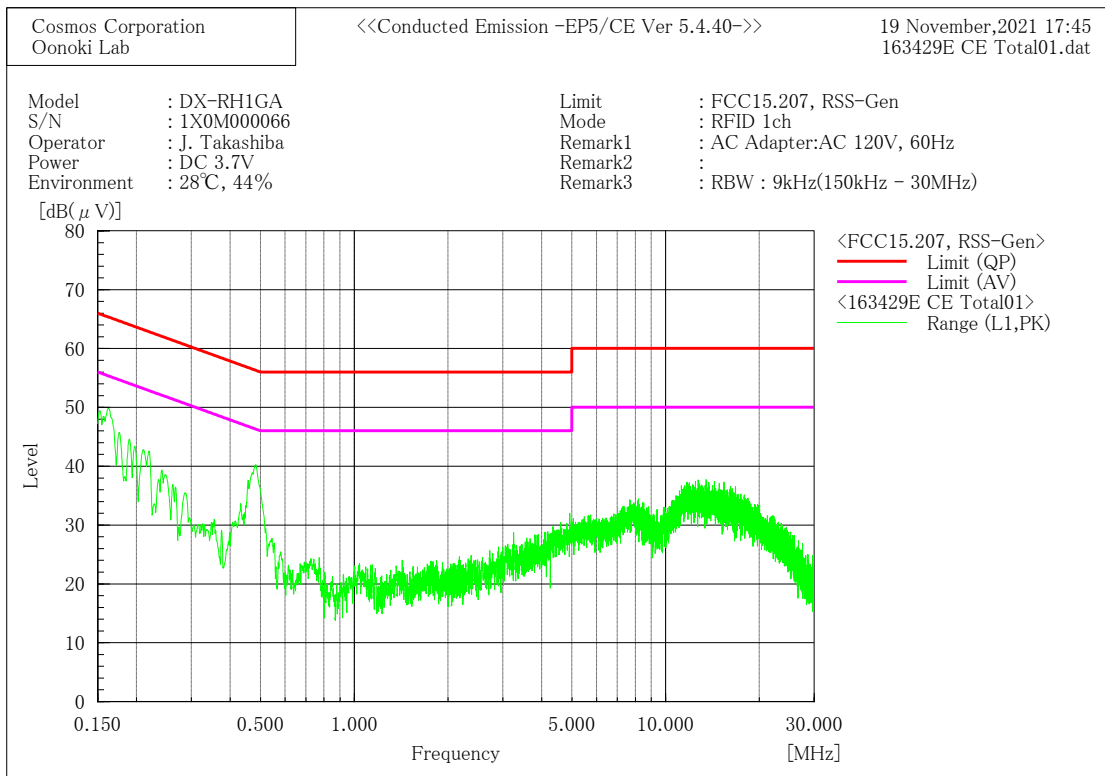
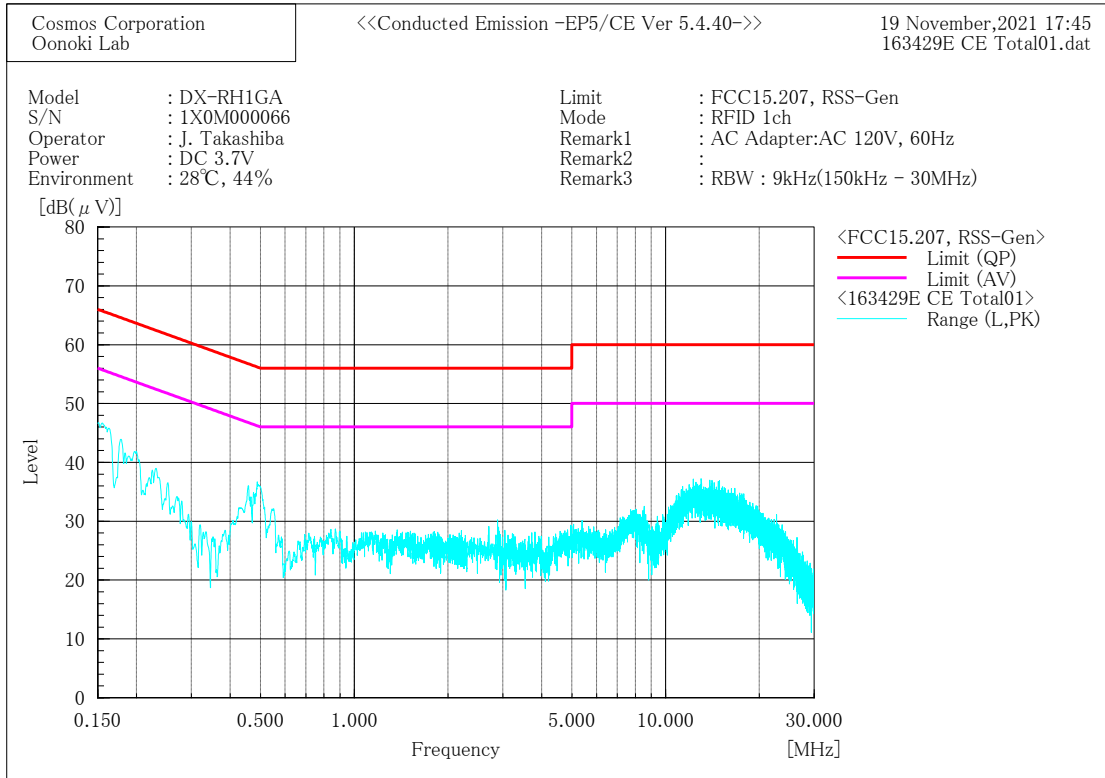

5.1.3 Test Detail (Continued)

Worst Test Data (Tx 25ch)

***** Cosmos Corporation *****
 <<Conducted Emission -EP5/CE Ver 5.4.40->>

19 November, 2021 17:53
 163429E CE Total02.dat

Limit : FCC15.207, RSS-Gen
 Model : DX-RH1GA
 S/N : 1XOM000066
 Operator : J. Takashiba
 Power : DC 3.7V
 Environment : 28°C, 44%
 Mode : RFID 25ch
 Remark1 : AC Adapter: AC 120V, 60Hz
 Remark2 :
 Remark3 : RBW : 9kHz (150kHz - 30MHz)

 Final Result

--- L1 Phase ---

No.	Frequency [MHz]	Reading QP [dB(μV)]	Reading AV [dB(μV)]	c. f [dB]	Result QP [dB(μV)]	Result AV [dB(μV)]	Limit QP [dB(μV)]	Limit AV [dB(μV)]	Margin QP [dB]	Margin AV [dB]
1	0.15052	30.7	20.6	10.2	40.9	30.8	66.0	56.0	25.1	25.2
2	0.48512	27.4	19.1	10.0	37.4	29.1	56.3	46.3	18.9	17.2
3	0.98402	15.5	9.4	10.0	25.5	19.4	56.0	46.0	30.5	26.6
4	4.18525	13.9	7.1	10.2	24.1	17.3	56.0	46.0	31.9	28.7
5	8.31647	17.5	11.3	10.2	27.7	21.5	60.0	50.0	32.3	28.5
6	12.16176	23.2	17.8	10.3	33.5	28.1	60.0	50.0	26.5	21.9

--- L2 Phase ---

No.	Frequency [MHz]	Reading QP [dB(μV)]	Reading AV [dB(μV)]	c. f [dB]	Result QP [dB(μV)]	Result AV [dB(μV)]	Limit QP [dB(μV)]	Limit AV [dB(μV)]	Margin QP [dB]	Margin AV [dB]
1	0.15012	30.4	19.8	10.3	40.7	30.1	66.0	56.0	25.3	25.9
2	0.4861	27.0	19.3	10.0	37.0	29.3	56.2	46.2	19.2	16.9
3	0.82152	15.3	6.4	10.0	25.3	16.4	56.0	46.0	30.7	29.6
4	2.83438	13.7	6.8	10.1	23.8	16.9	56.0	46.0	32.2	29.1
5	7.78375	18.6	11.7	10.2	28.8	21.9	60.0	50.0	31.2	28.1
6	12.98347	22.8	17.9	10.4	33.2	28.3	60.0	50.0	26.8	21.7

5.1.3 Test Detail (Continued)

Worst Test Data (Tx 25ch)

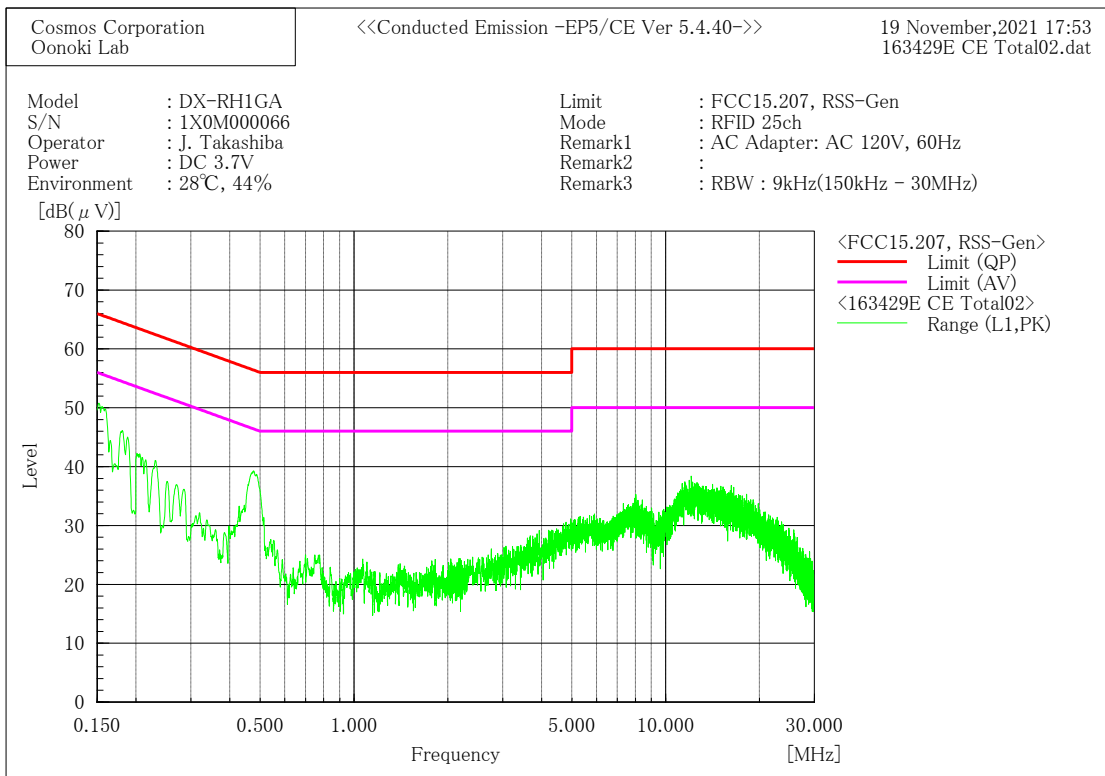
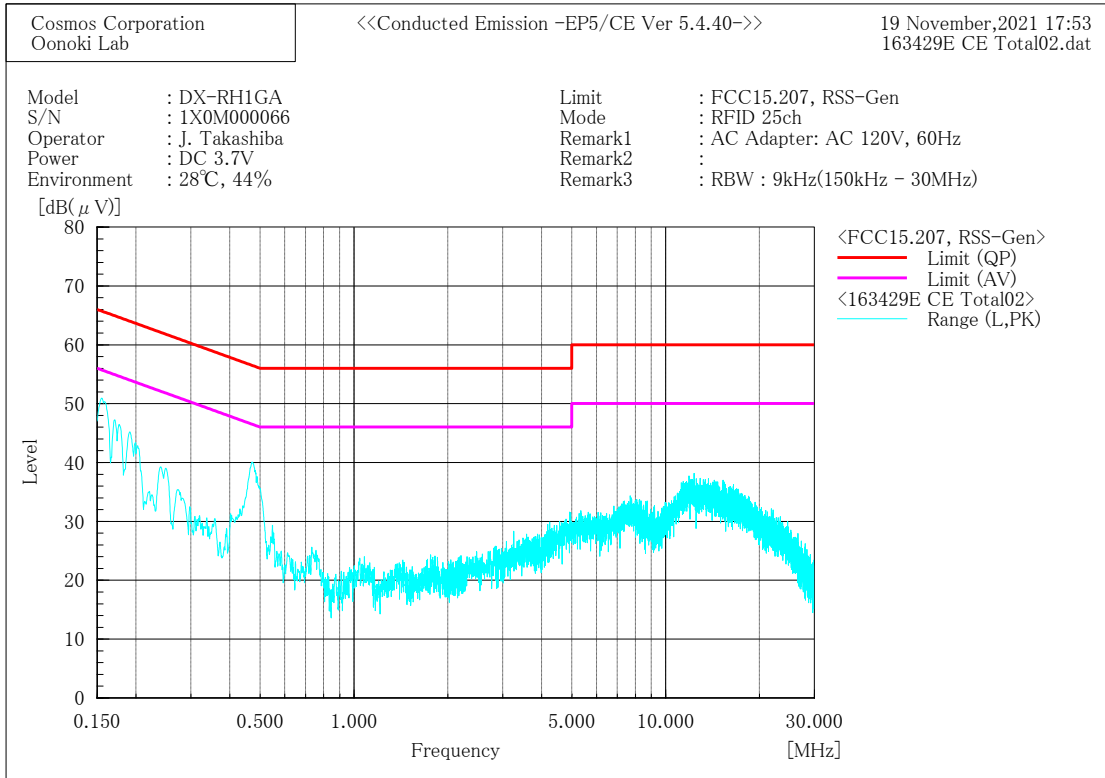

5.1.3 Test Detail (Continued)

Worst Test Data (Tx 50ch)

***** Cosmos Corporation *****
 <<Conducted Emission -EP5/CE Ver 5.4.40->>

19 November, 2021 18:08
 163429E CE Total03.dat

Limit : FCC15.207, RSS-Gen
 Model : DX-RH1GA
 S/N : 1XOM000066
 Operator : J. Takashiba
 Power : DC 3.7V
 Environment : 28°C, 44%
 Mode : RFID 50ch
 Remark1 : AC Adapter: AC120V, 60Hz
 Remark2 :
 Remark3 : RBW : 9kHz (150kHz - 30MHz)

 Final Result

--- L1 Phase ---

No.	Frequency [MHz]	Reading QP [dB(μV)]	Reading AV [dB(μV)]	c. f [dB]	Result QP [dB(μV)]	Result AV [dB(μV)]	Limit QP [dB(μV)]	Limit AV [dB(μV)]	Margin QP [dB]	Margin AV [dB]
1	0.15052	30.8	20.7	10.2	41.0	30.9	66.0	56.0	25.0	25.1
2	0.48475	27.6	19.3	10.0	37.6	29.3	56.3	46.3	18.7	17.0
3	0.98473	15.3	9.2	10.0	25.3	19.2	56.0	46.0	30.7	26.8
4	4.18626	13.8	7.2	10.2	24.0	17.4	56.0	46.0	32.0	28.6
5	8.3015	18.3	11.8	10.2	28.5	22.0	60.0	50.0	31.5	28.0
6	12.17337	22.8	17.5	10.3	33.1	27.8	60.0	50.0	26.9	22.2

--- L2 Phase ---

No.	Frequency [MHz]	Reading QP [dB(μV)]	Reading AV [dB(μV)]	c. f [dB]	Result QP [dB(μV)]	Result AV [dB(μV)]	Limit QP [dB(μV)]	Limit AV [dB(μV)]	Margin QP [dB]	Margin AV [dB]
1	0.15036	30.9	20.5	10.3	41.2	30.8	66.0	56.0	24.8	25.2
2	0.48735	27.6	19.3	10.0	37.6	29.3	56.2	46.2	18.6	16.9
3	0.82121	10.2	6.2	10.0	20.2	16.2	56.0	46.0	35.8	29.8
4	2.83845	13.8	6.6	10.1	23.9	16.7	56.0	46.0	32.1	29.3
5	7.78057	18.4	12.2	10.2	28.6	22.4	60.0	50.0	31.4	27.6
6	12.98475	23.1	18.6	10.4	33.5	29.0	60.0	50.0	26.5	21.0

5.1.3 Test Detail (Continued)

Worst Test Data (Tx 50ch)

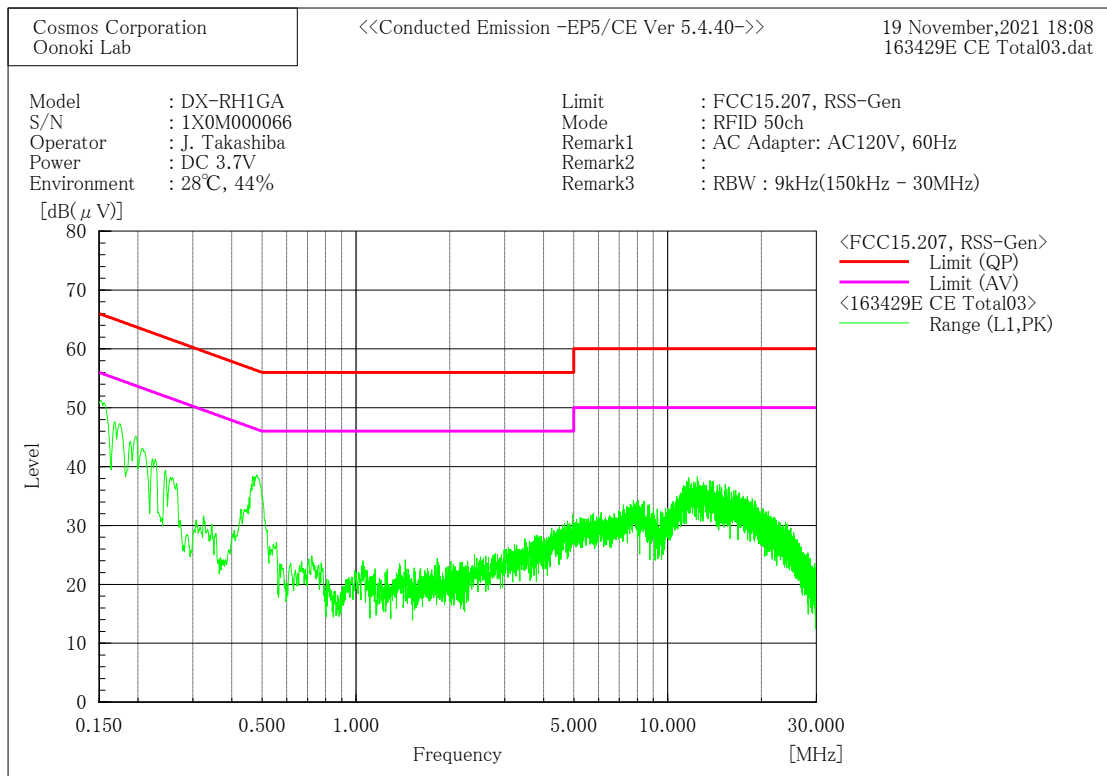
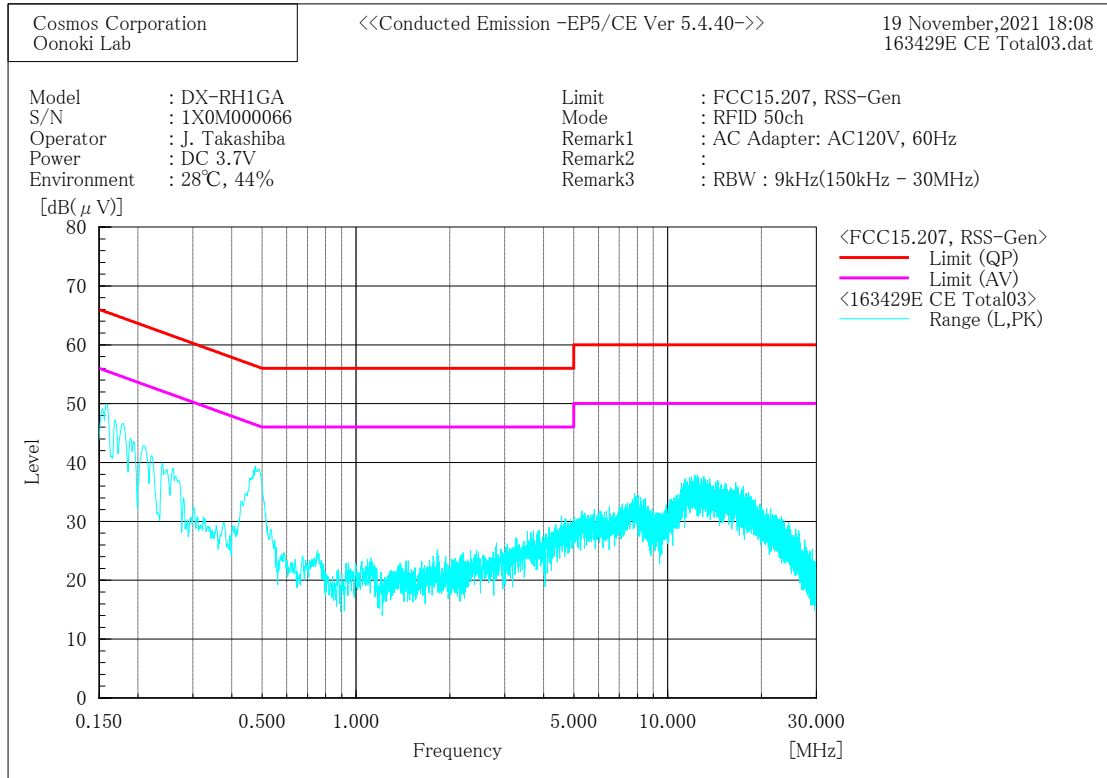

5.2 Transmitter Spurious Emission (Radiated)

5.2.1 Setting Remarks

In the frequency range from 30 MHz to 10 GHz (as 10th harmonics), the electric field strength was measured in accordance with ANSI C63.10 clause 6.5 and 6.6.

The test setup was made on the table installed in a semi-anechoic chamber. The non-conductive table was placed on the turntable, and the EUT was put on the non-conductive table. The EUT was measured at 1 m to 4 m height of the antenna.

The turntable was fully rotated. The highest radiation from the equipment was recorded.

The measurement was carried out with both horizontal and vertical antenna polarization.

The test receiver with Peak, Quasi Peak and Average detector is in accordance with CISPR 16-1-1.

The measurement was carried out with the measuring distance of 3 m.

Setting Condition of Test receiver

Frequency range	Detector	RBW
30 MHz to 1 GHz	Quasi-peak	120 kHz
1 GHz to 25 GHz	Peak	1 MHz
	Average	1 MHz

5.2.2 Limit

Frequency range	Field Strength (Distance)			
	[μ V/m]		[dB μ V/m]	
30 MHz to 88 MHz	100	(3 m)	40.0	(3 m)
88 MHz to 216 MHz	150	(3 m)	43.5	(3 m)
216 MHz to 960 MHz	200	(3 m)	46.0	(3 m)
Above 960 MHz	500	(3 m)	53.9	(3 m)

5.2.3 Test Detail

Result: Passed

Uncertainty of measurement result	:	±3.97 dB	
Test operator	:	Junya Takashiba	
Date of testing	:	2021-11-01	2021-11-01
Room temperature	:	20°C	22 °C
Relative humidity	:	55 %	55 %

Sample Calculation

Result = Reading + c.f
= 44.6 + (-4.2)
= 40.4

Margin = Limit – Result
= 46.0 – 40.4
= 5.6

Note:

c.f (Correction Factor) = Cable Attenuation Factor + Antenna Factor – Amplifier Gain

5.2.3 Test Detail (Continued)

<30 MHz to 1 GHz>

Worst Test Data (Tx 1ch)

***** Cosmos Corporation *****
 <<Radiated Emission EP5/RE Ver 5.7.1>> 1 November, 2021 13:59
 163429E RE MHz 11 S.dat

Limit : FCC15.209, RSS-Gen (MHz) 3m
 Model : DX-RH1GA
 Serial : 1X0M000066
 Operator : J. Takashiba
 Power : DC 3.7V
 Environment : 20°C, 55%, 1005hPa
 Mode : RFID 1ch
 Remark : Y axis
 Remark :
 Remark : RBW:120kHz

 Final Result

--- Horizontal Polarization (QP)---

No.	Frequency [MHz]	Reading [dB(μV)]	c.f [dB(1/m)]	Result [dB(μV/m)]	Limit [dB(μV/m)]	Margin [dB]	Height [cm]	Angle [°]
1	240.272	44.6	-4.2	40.4	46.0	5.6	100.0	317.0
2	366.037	38.6	-5.2	33.4	46.0	12.6	103.0	185.0
3	840.021	39.5	3.7	43.2	46.0	2.8	100.0	131.0
4	888.000	33.3	10.3	43.6	46.0	2.4	157.0	0.0

--- Vertical Polarization (QP)---

No.	Frequency [MHz]	Reading [dB(μV)]	c.f [dB(1/m)]	Result [dB(μV/m)]	Limit [dB(μV/m)]	Margin [dB]	Height [cm]	Angle [°]
1	888.000	26.8	10.3	37.1	46.0	8.9	259.0	320.0
2	953.968	30.6	5.3	35.9	46.0	10.1	201.0	51.0

5.2.3 Test Detail (Continued)

<30 MHz to 1 GHz>
Worst Test Data (Tx 1ch)

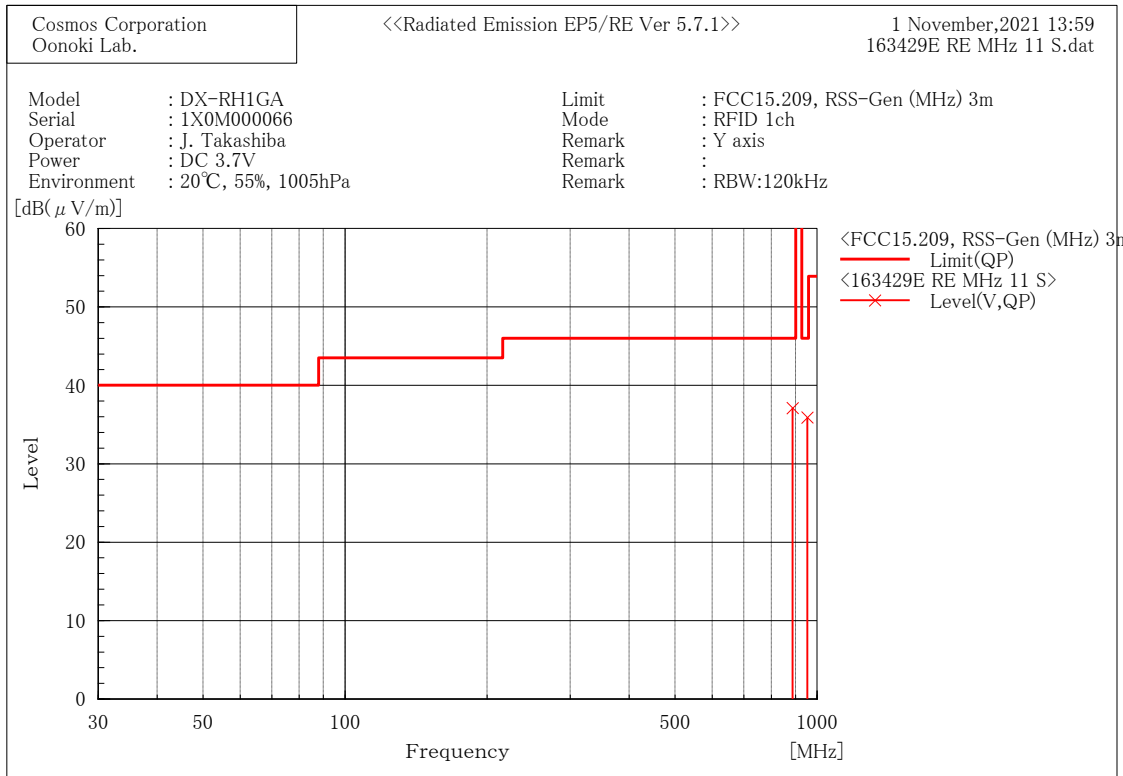
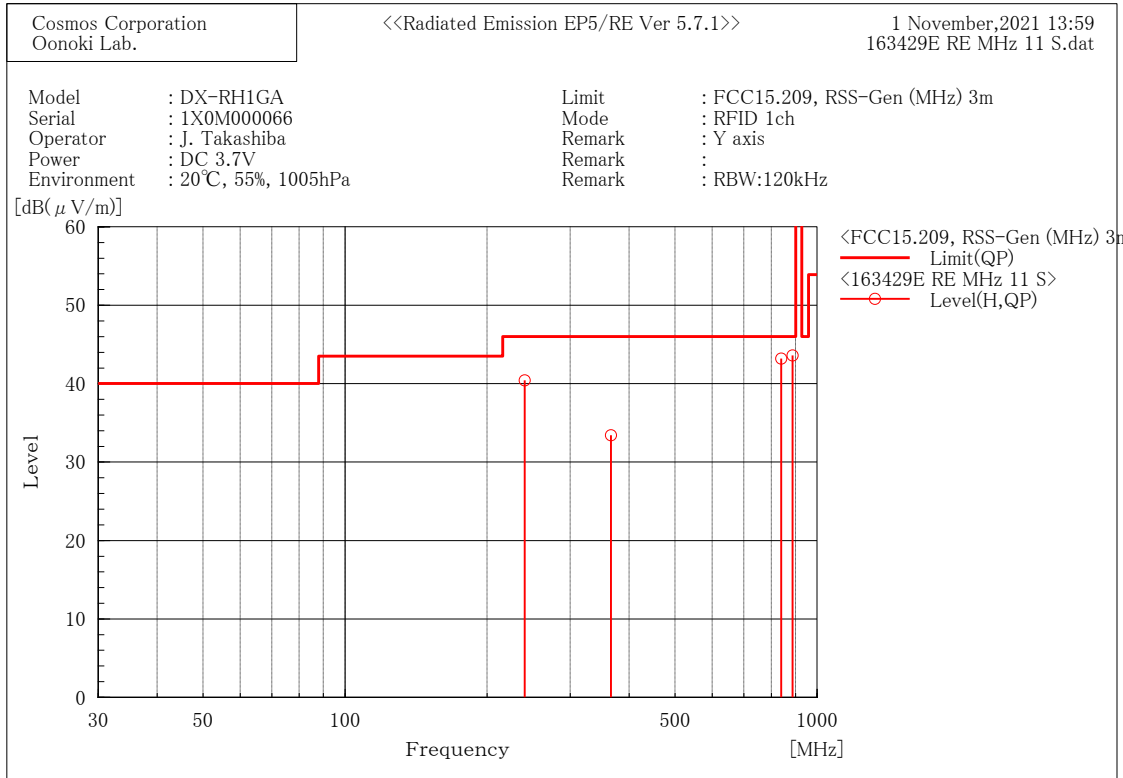

5.2.3 Test Detail (Continued)

<30 MHz to 1 GHz>

Worst Test Data (Tx 25ch)

***** Cosmos Corporation *****
 <<Radiated Emission EP5/RE Ver 5.7.1>> 1 November, 2021 11:30
 163429E RE MHz 10. dat

Limit : FCC15.209, RSS-Gen (MHz) 3m
 Model : DX-RH1GA
 Serial : 1X0M000066
 Operator : J. Takashiba
 Power : DC 3.7V
 Environment : 20°C, 55%, 1005hPa
 Mode : RFID 25ch
 Remark : Y axis
 Remark :
 Remark : RBW:120kHz

 Final Result

--- Horizontal Polarization (QP)---

No.	Frequency [MHz]	Reading [dB(μV)]	c. f [dB(1/m)]	Result [dB(μV/m)]	Limit [dB(μV/m)]	Margin [dB]	Height [cm]	Angle [°]
1	240.291	45.4	-4.2	41.2	46.0	4.8	133.0	53.0
2	372.417	41.8	-5.2	36.6	46.0	9.4	105.0	12.0
3	840.021	38.3	3.7	42.0	46.0	4.0	100.0	4.0

--- Vertical Polarization (QP)---

No.	Frequency [MHz]	Reading [dB(μV)]	c. f [dB(1/m)]	Result [dB(μV/m)]	Limit [dB(μV/m)]	Margin [dB]	Height [cm]	Angle [°]
1	372.417	31.6	-5.2	26.4	46.0	19.6	100.0	308.0
2	600.026	34.8	-0.3	34.5	46.0	11.5	100.0	168.0
3	954.032	30.8	5.3	36.1	46.0	9.9	195.0	8.0

5.2.3 Test Detail (Continued)

<30 MHz to 1 GHz>
 Worst Test Data (Tx 25ch)

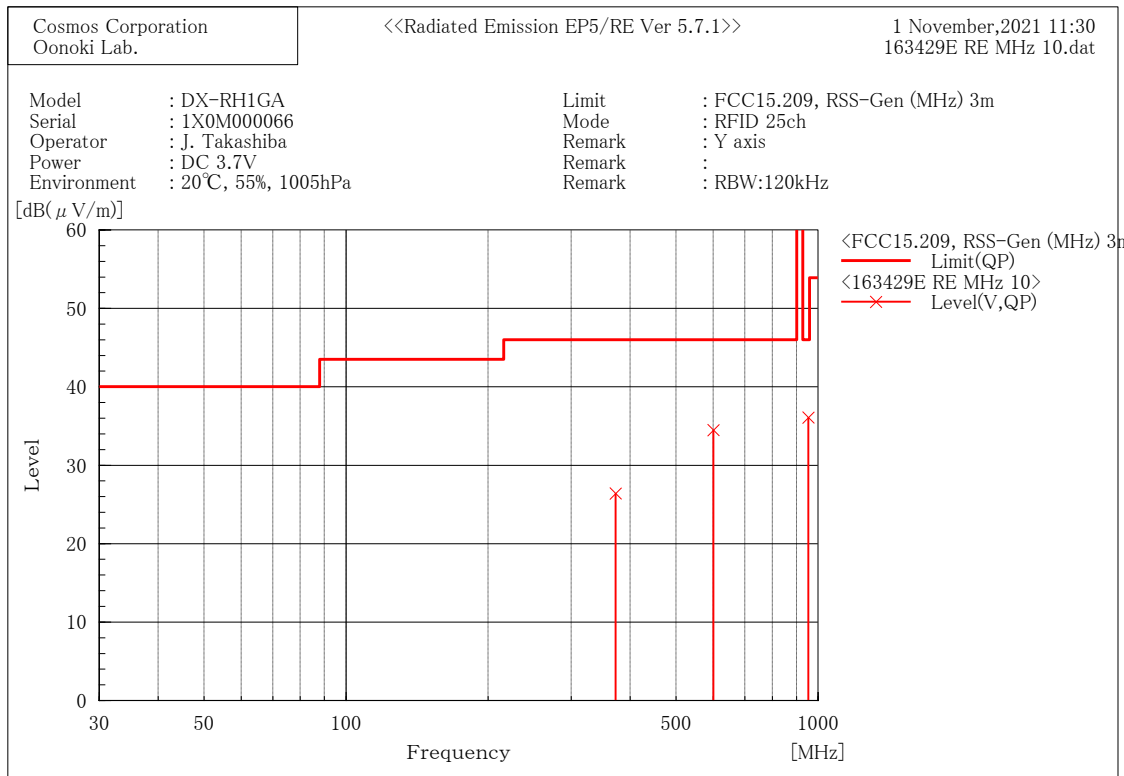
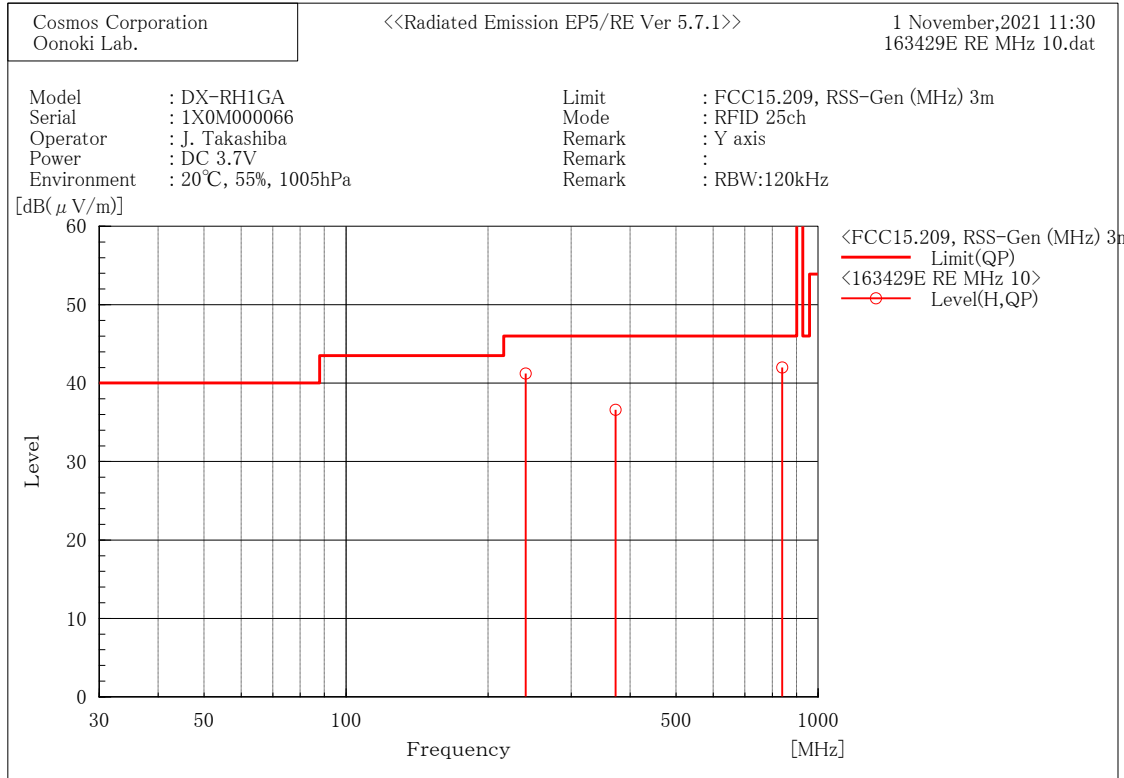

5.2.3 Test Detail (Continued)

<30 MHz to 1 GHz>

Worst Test Data (Tx 50ch)

***** Cosmos Corporation *****
 <<Radiated Emission EP5/RE Ver 5.7.1>> 10 November, 2021 14:08
 163429E RE MHz 12 S.dat

Limit : FCC15.209, RSS-Gen (MHz) 3m
 Model : DX-RH1GA
 Serial : 1X0M000066
 Operator : J. Takashiba
 Power : DC 3.7V
 Environment : 20°C, 55%, 1005hPa
 Mode : RFID 50ch
 Remark : Y axis
 Remark :
 Remark : RBW:120kHz

 Final Result

--- Horizontal Polarization (QP)---

No.	Frequency [MHz]	Reading [dB(μV)]	c.f [dB(1/m)]	Result [dB(μV/m)]	Limit [dB(μV/m)]	Margin [dB]	Height [cm]	Angle [°]
1	240.272	45.2	-4.2	41.0	46.0	5.0	132.0	227.0
2	354.893	40.9	-5.2	35.7	46.0	10.3	101.0	354.0
3	840.021	36.2	3.7	39.9	46.0	6.1	168.0	190.0
4	983.996	35.2	5.9	41.1	53.9	12.8	137.0	210.0

--- Vertical Polarization (QP)---

No.	Frequency [MHz]	Reading [dB(μV)]	c.f [dB(1/m)]	Result [dB(μV/m)]	Limit [dB(μV/m)]	Margin [dB]	Height [cm]	Angle [°]
1	70.596	31.8	-17.3	14.5	40.0	25.5	100.0	261.0
2	934.725	30.8	10.4	41.2	46.0	4.8	103.0	265.0

5.2.3 Test Detail (Continued)

<30 MHz to 1 GHz>
Worst Test Data (Tx 50ch)

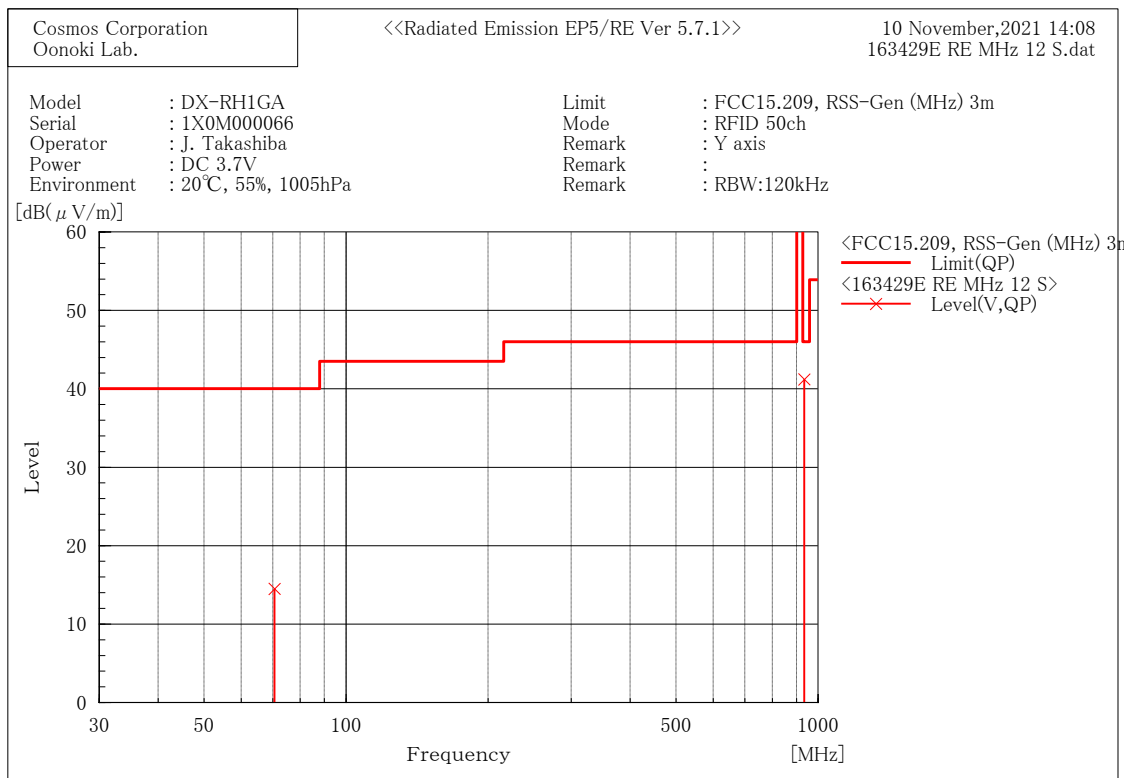
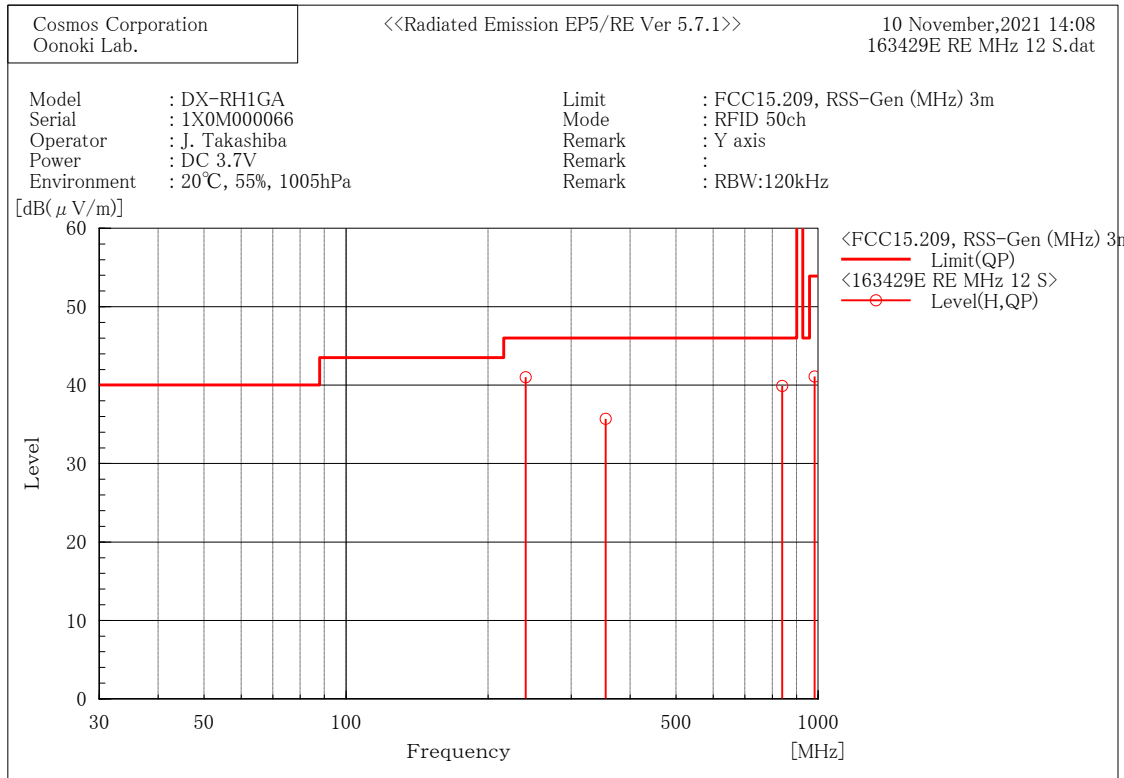

5.2.3 Test Detail (Continued)

<1 GHz to 10 GHz>

Worst Test Data (Tx 1ch)

***** Cosmos Corporation *****
 <<Radiated Emission EP5/RE Ver 5.7.1>> 1 November, 2021 16:49
 163429E RE GHz 02-04.dat

Limit : FCC15.209, RSS-Gen (GHz) 3m
 Model : DX-RH1GA
 Serial : 1XOM000066
 Operator : J. Takashiba
 Power : DC 3.7V
 Environment : 22°C, 55%, 1006hPa
 Mode : RFID 1ch
 Remark : Y axis
 Remark :
 Remark : RBW:1MHz

 Final Result

--- Horizontal Polarization (PK)---

No.	Frequency [MHz]	Reading [dB(μV)]	c.f [dB(1/m)]	Result [dB(μV/m)]	Limit [dB(μV/m)]	Margin [dB]	Height [cm]	Angle [°]
1	1805.350	45.4	-3.8	41.6	73.9	32.3	100.0	21.0
2	3610.733	55.4	0.2	55.6	73.9	18.3	100.0	21.0

--- Horizontal Polarization (AV)---

No.	Frequency [MHz]	Reading [dB(μV)]	c.f [dB(1/m)]	Result [dB(μV/m)]	Limit [dB(μV/m)]	Margin [dB]	Height [cm]	Angle [°]
1	1805.350	39.8	-3.8	36.0	53.9	17.9	100.0	21.0
2	3610.733	51.0	0.2	51.2	53.9	2.7	100.0	21.0

--- Vertical Polarization (PK)---

No.	Frequency [MHz]	Reading [dB(μV)]	c.f [dB(1/m)]	Result [dB(μV/m)]	Limit [dB(μV/m)]	Margin [dB]	Height [cm]	Angle [°]
1	1484.900	47.4	-4.2	43.2	73.9	30.7	107.0	201.0
2	3611.117	53.3	0.2	53.5	73.9	20.4	109.0	57.0

--- Vertical Polarization (AV)---

No.	Frequency [MHz]	Reading [dB(μV)]	c.f [dB(1/m)]	Result [dB(μV/m)]	Limit [dB(μV/m)]	Margin [dB]	Height [cm]	Angle [°]
1	1484.900	43.4	-4.2	39.2	53.9	14.7	107.0	201.0
2	3611.117	50.8	0.2	51.0	53.9	2.9	109.0	57.0

5.2.3 Test Detail (Continued)

<1 GHz to 10 GHz>
 Worst Test Data (Tx 1ch)

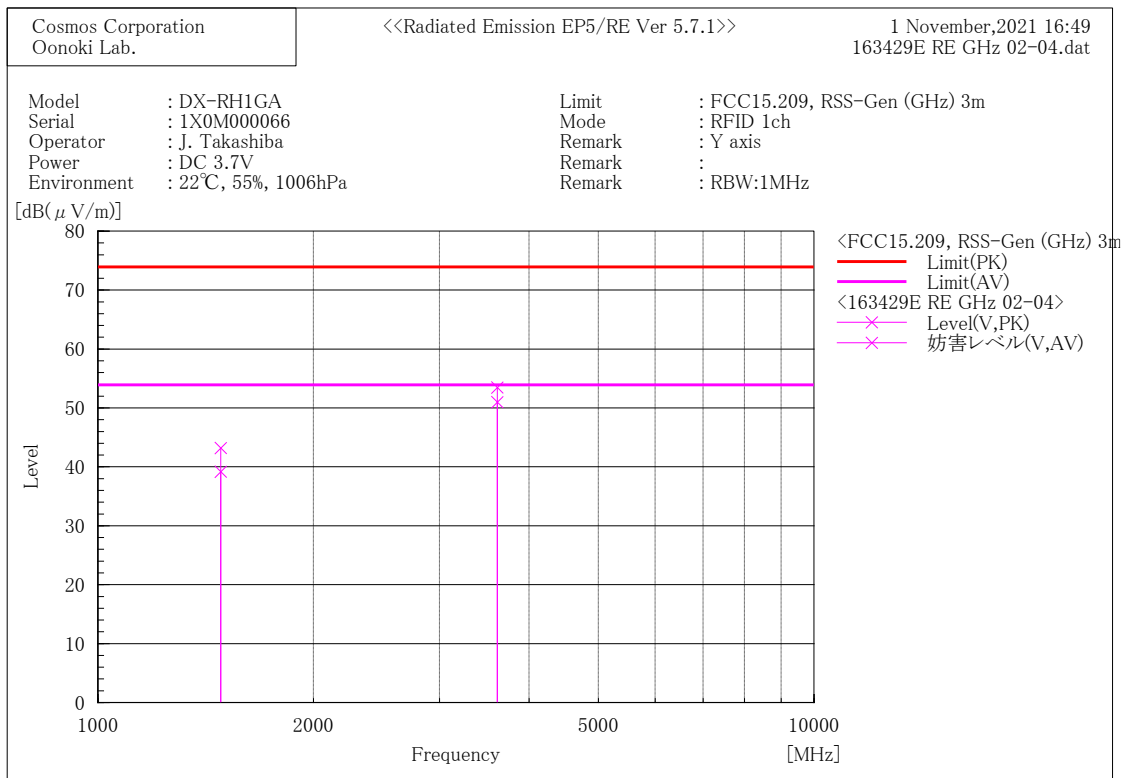
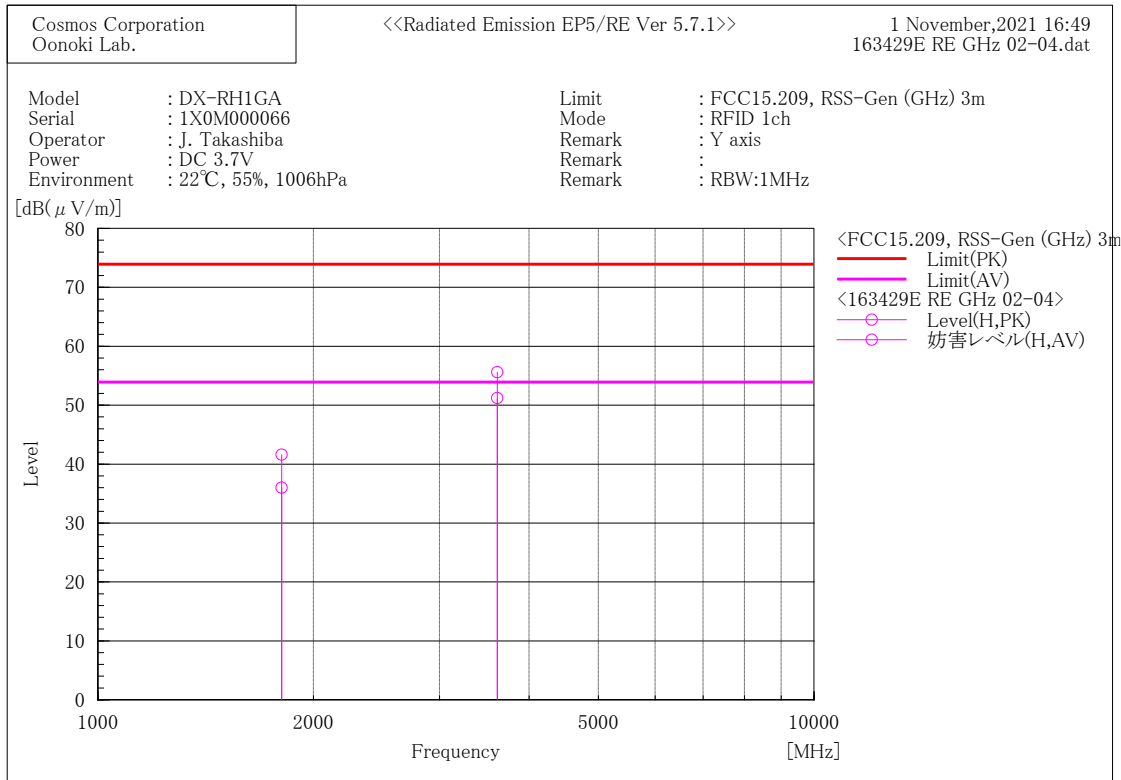

5.2.3 Test Detail (Continued)

<1 GHz to 10 GHz>

Worst Test Data (Tx 25ch)

***** Cosmos Corporation *****
 <<Radiated Emission EP5/RE Ver 5.7.1>> 1 November, 2021 15:49
 163429E RE GHz 02-02. dat

Limit : FCC15.209, RSS-Gen (GHz) 3m
 Model : DX-RH1GA
 Serial : 1X0M000066
 Operator : J. Takashiba
 Power : DC 3.7V
 Environment : 22°C, 55%, 1006hPa
 Mode : RFID 25ch
 Remark : Y axis
 Remark :
 Remark : RBW:1MHz

 Final Result

--- Horizontal Polarization (PK)---

No.	Frequency [MHz]	Reading [dB(μV)]	c. f [dB(1/m)]	Result [dB(μV/m)]	Limit [dB(μV/m)]	Margin [dB]	Height [cm]	Angle [°]
1	1829.369	39.8	-3.9	35.9	73.9	38.0	146.0	183.0
2	3659.033	52.6	0.2	52.8	73.9	21.1	230.0	46.0

--- Horizontal Polarization (AV)---

No.	Frequency [MHz]	Reading [dB(μV)]	c. f [dB(1/m)]	Result [dB(μV/m)]	Limit [dB(μV/m)]	Margin [dB]	Height [cm]	Angle [°]
1	1829.369	35.4	-3.9	31.5	53.9	22.4	146.0	183.0
2	3659.033	48.9	0.2	49.1	53.9	4.8	230.0	46.0

--- Vertical Polarization (PK)---

No.	Frequency [MHz]	Reading [dB(μV)]	c. f [dB(1/m)]	Result [dB(μV/m)]	Limit [dB(μV/m)]	Margin [dB]	Height [cm]	Angle [°]
1	1829.400	47.1	-3.9	43.2	73.9	30.7	204.0	23.0
2	3659.033	51.4	0.2	51.6	73.9	22.3	227.0	354.0

--- Vertical Polarization (AV)---

No.	Frequency [MHz]	Reading [dB(μV)]	c. f [dB(1/m)]	Result [dB(μV/m)]	Limit [dB(μV/m)]	Margin [dB]	Height [cm]	Angle [°]
1	1829.400	40.3	-3.9	36.4	53.9	17.5	204.0	23.0
2	3659.033	45.4	0.2	45.6	53.9	8.3	227.0	354.0

5.2.3 Test Detail (Continued)

<1 GHz to 10 GHz>
Worst Test Data (Tx 25ch)

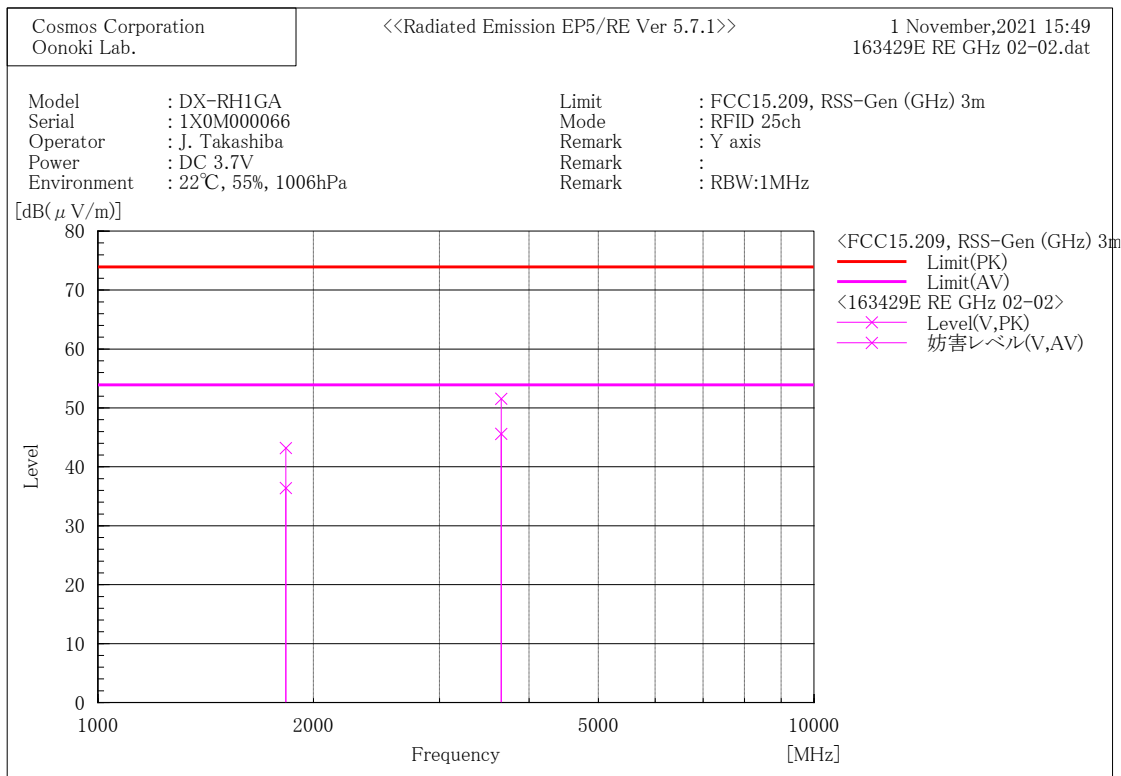
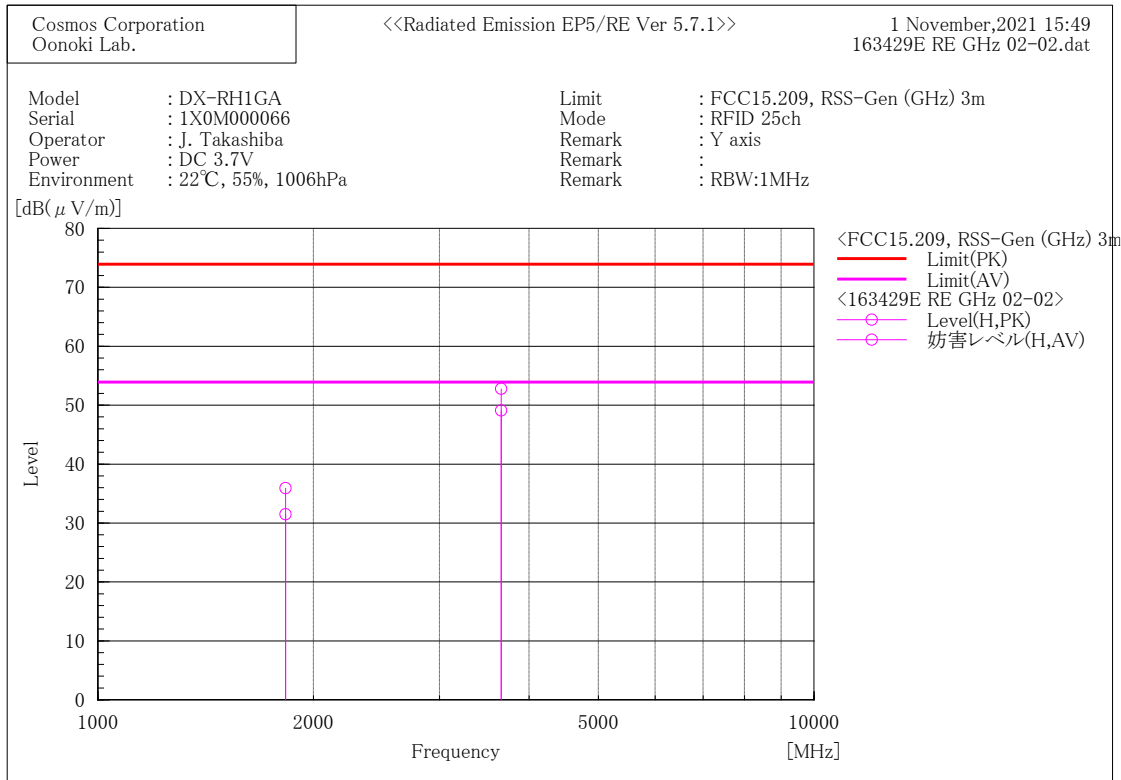

5.2.3 Test Detail (Continued)

<1 GHz to 10 GHz>

Worst Test Data (Tx 50ch)

***** Cosmos Corporation *****
 <<Radiated Emission EP5/RE Ver 5.7.1>> 1 November, 2021 17:59
 163429E RE GHz 02-05.dat

Limit : FCC15.209, RSS-Gen (GHz) 3m
 Model : DX-RH1GA
 Serial : 1X0M000066
 Operator : J. Takashiba
 Power : DC 3.7V
 Environment : 22°C, 55%, 1006hPa
 Mode : RFID 50ch
 Remark : Y axis
 Remark :
 Remark : RBW:1MHz

 Final Result

--- Horizontal Polarization (PK)---

No.	Frequency [MHz]	Reading [dB(μV)]	c. f [dB(1/m)]	Result [dB(μV/m)]	Limit [dB(μV/m)]	Margin [dB]	Height [cm]	Angle [°]
1	1854.533	49.5	-4.0	45.5	73.9	28.4	100.0	354.0
2	3708.867	51.8	0.4	52.2	73.9	21.7	250.0	341.0

--- Horizontal Polarization (AV)---

No.	Frequency [MHz]	Reading [dB(μV)]	c. f [dB(1/m)]	Result [dB(μV/m)]	Limit [dB(μV/m)]	Margin [dB]	Height [cm]	Angle [°]
1	1854.533	44.3	-4.0	40.3	53.9	13.6	100.0	354.0
2	3708.867	48.4	0.4	48.8	53.9	5.1	250.0	341.0

--- Vertical Polarization (PK)---

No.	Frequency [MHz]	Reading [dB(μV)]	c. f [dB(1/m)]	Result [dB(μV/m)]	Limit [dB(μV/m)]	Margin [dB]	Height [cm]	Angle [°]
1	2163.500	47.5	-1.7	45.8	73.9	28.1	100.0	194.0
2	3708.867	51.8	0.4	52.2	73.9	21.7	251.0	70.0

--- Vertical Polarization (AV)---

No.	Frequency [MHz]	Reading [dB(μV)]	c. f [dB(1/m)]	Result [dB(μV/m)]	Limit [dB(μV/m)]	Margin [dB]	Height [cm]	Angle [°]
1	2163.500	43.2	-1.7	41.5	53.9	12.4	100.0	194.0
2	3708.867	48.6	0.4	49.0	53.9	4.9	251.0	70.0

5.2.3 Test Detail (Continued)

<1 GHz to 10 GHz>
 Worst Test Data (Tx 50ch)

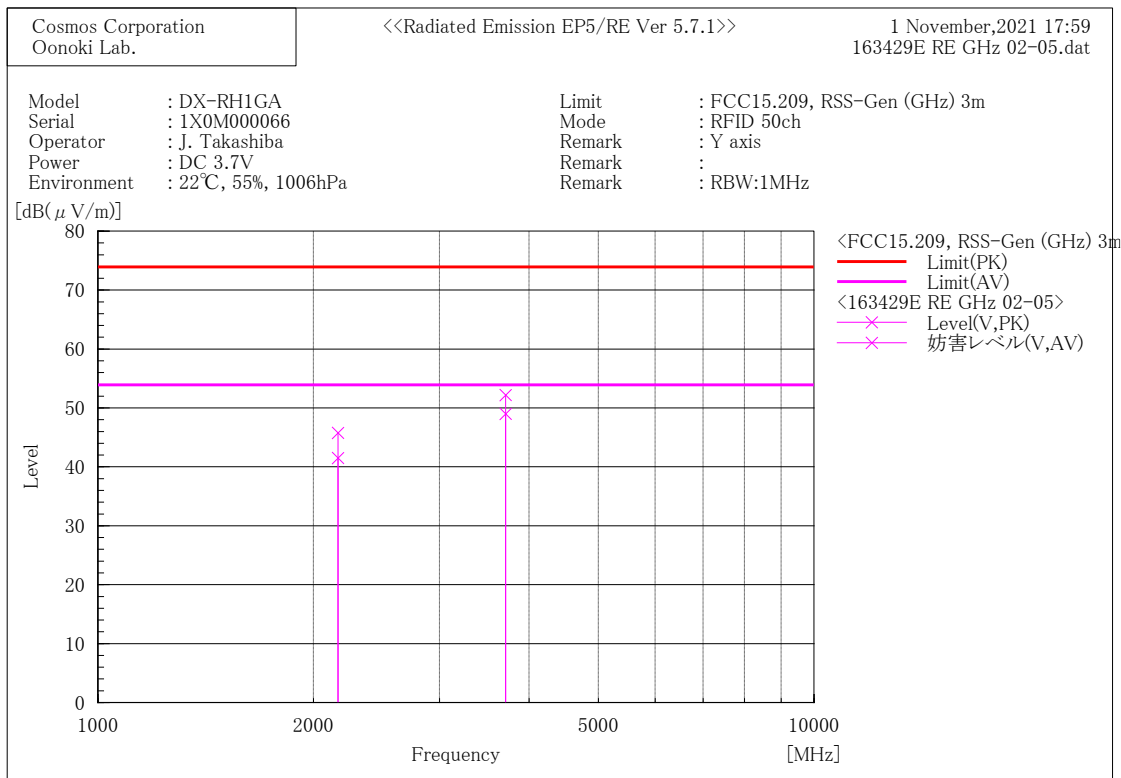
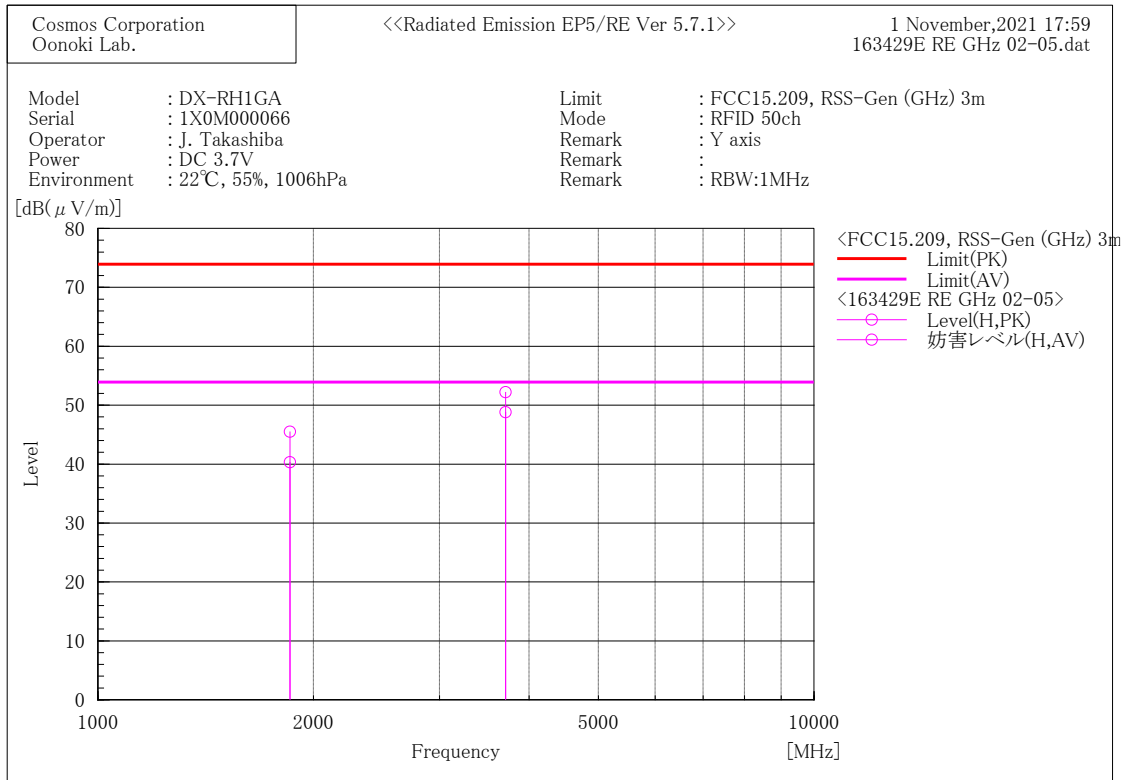

5.3 20 dB Bandwidth

5.3.1 Setting Remarks

The test was performed in accordance with ANSI C63.10 clause 6.9.2.

The both side of 20 dB down value from peak power were measured by using 20 dB bandwidth measurement function.

The spectrum analyzer is set as following:

·Frequency Span	: 300 kHz
·Resolution Bandwidth	: 3 kHz
·Video Bandwidth	: 9 kHz
·Detector Mode	: Peak
·Trace Mode	: Max Hold

5.3.2 Limit

Intentional radiators must be designed to ensure that the 20 dB bandwidth of the emission is contained within the frequency band designated in the rule section under which the equipment is operated.

5.3.3 Test Detail

Result: Passed

Uncertainty of measurement result	: ±0.025 %
Test operator	: Junya Takashiba
Date of testing	: 2021-11-25
Room temperature	: 20 °C
Relative humidity	: 25 %

Frequency [MHz]	Measured Bandwidth [kHz]
902.75	50.98
914.75	51.61
927.25	52.84

5.3.3 Test Detail (Continued)

Test Data (1ch)

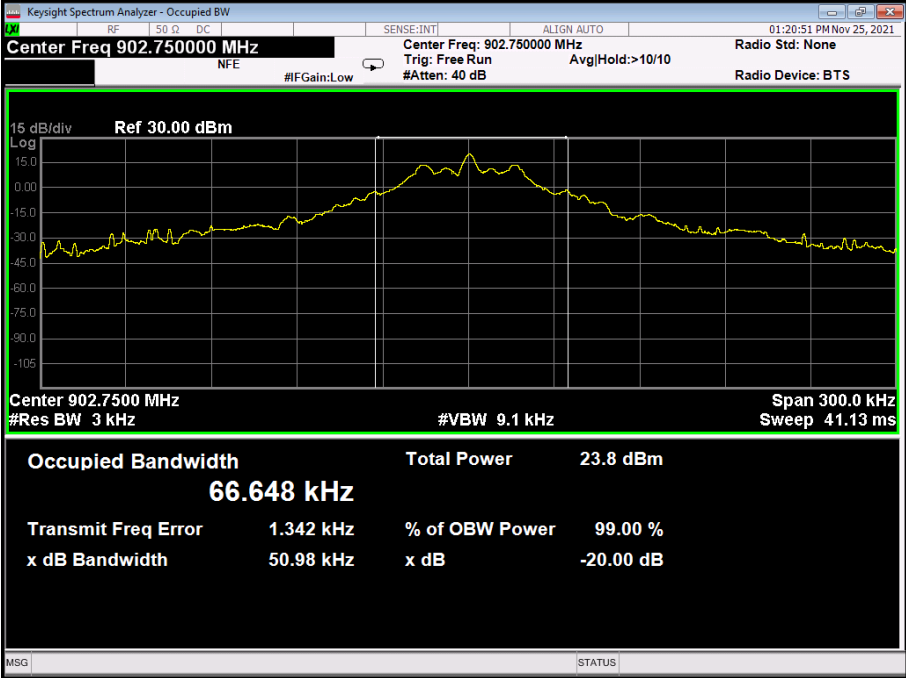

Test Data (25ch)

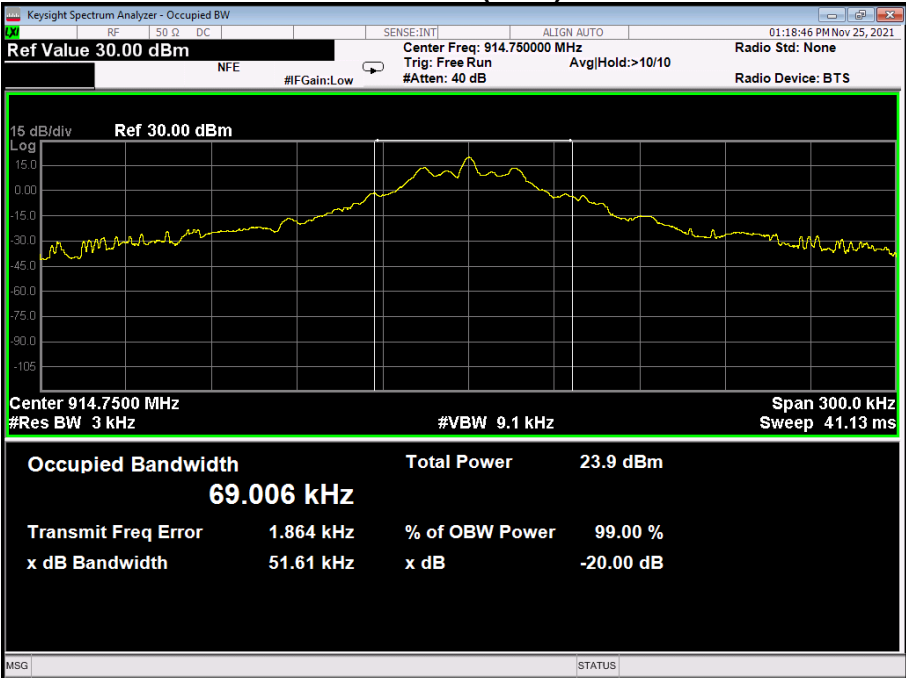

5.3.3 Test Detail (Continued)

Test Data (50ch)

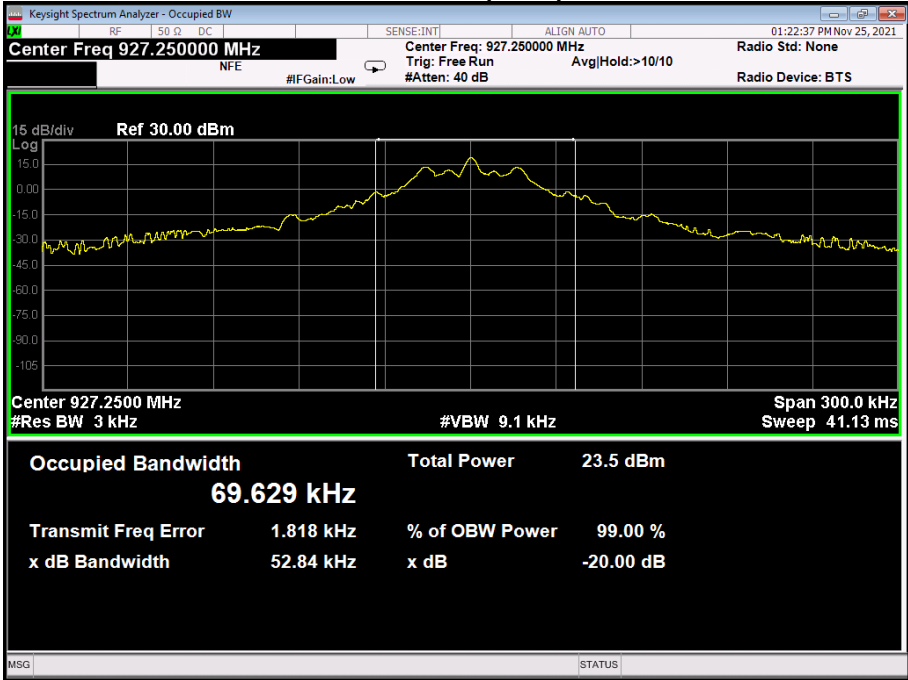

5.4 Carrier Frequency Separation

5.4.1 Setting Remarks

The test was performed in accordance with ANSI C63.10 clause 7.8.2.
The spectrum analyzer is set as following:

·Frequency Span	: 1 MHz
·Resolution Bandwidth	: 9 kHz
·Video Bandwidth	: 100 kHz
·Detector Mode	: Peak
·Trace Mode	: Max Hold

5.4.2 Limit

Frequency hopping systems shall have hopping channel carrier frequencies separated by a minimum of 25 kHz or the 20 dB bandwidth of the hopping channel, whichever is greater.

5.4.3 Result

Result: Passed

Uncertainty of measurement result	: ± 0.097 %
Test operator	: Junya Takashiba
Date of testing	: 2021-11-30
Room temperature	: 20 °C
Relative humidity	: 31 %

5.4.3 Test Detail (Continued)

Test Data

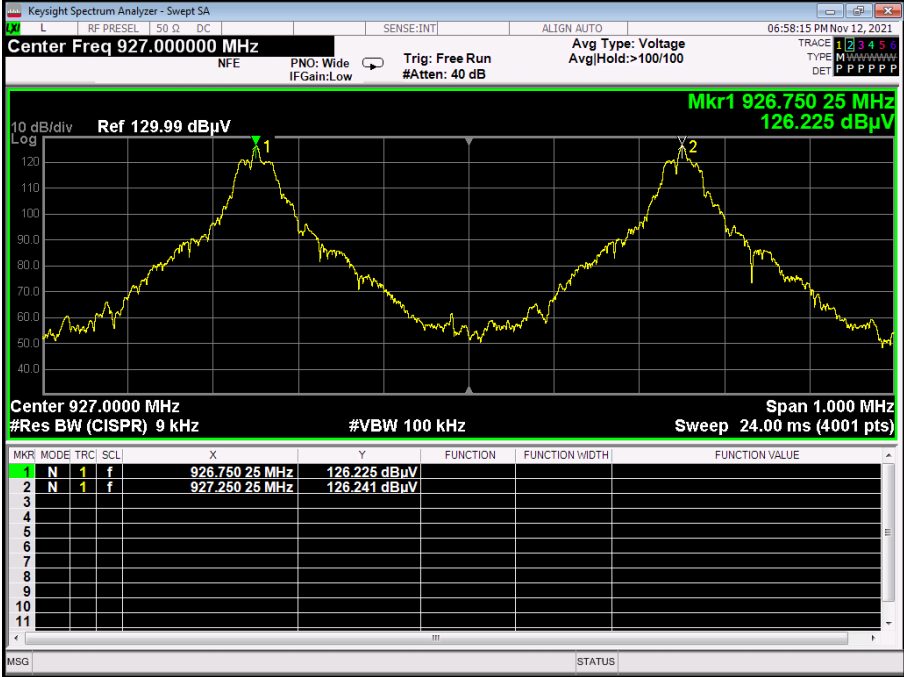

Carrier Frequency Separation [kHz]	Limit [kHz]
500	>69.006 (>20dB BW)

5.5 Average Time of Occupancy

5.5.1 Setting Remarks

The test was performed in accordance with ANSI C63.10 clause 7.8.4.
The spectrum analyzer is set as following:

·Resolution Bandwidth	: 100 kHz
·Video Bandwidth	: 300 kHz
·Detector Mode	: Peak

5.5.2 Test Detail

Result: Passed

Uncertainty of measurement result	: ± 0.012 %
Test operator	: Junya Takashiba
Date of testing	: 2021-11-30
Room temperature	: 20 °C
Relative humidity	: 31 %

5.5.2 Test Detail (Continued)

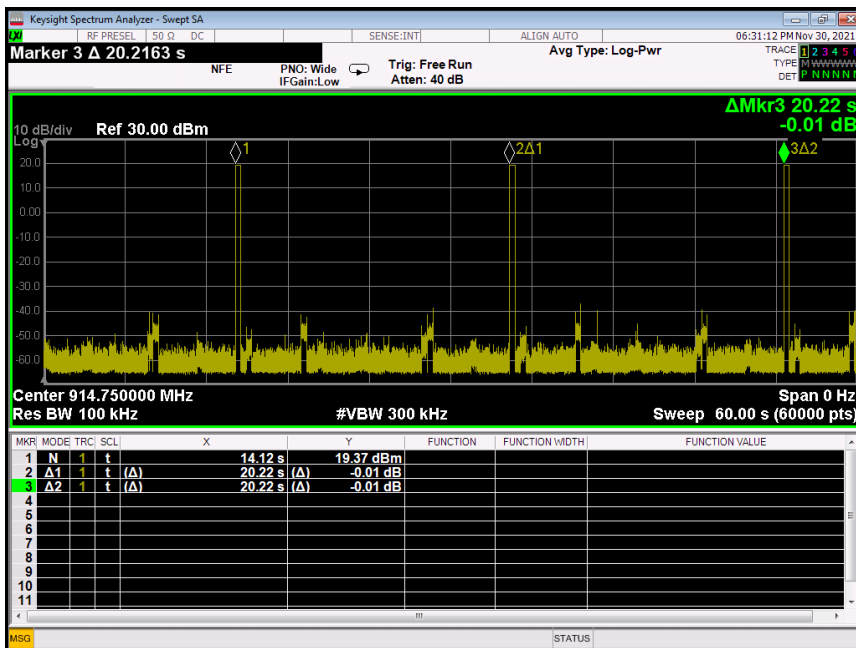
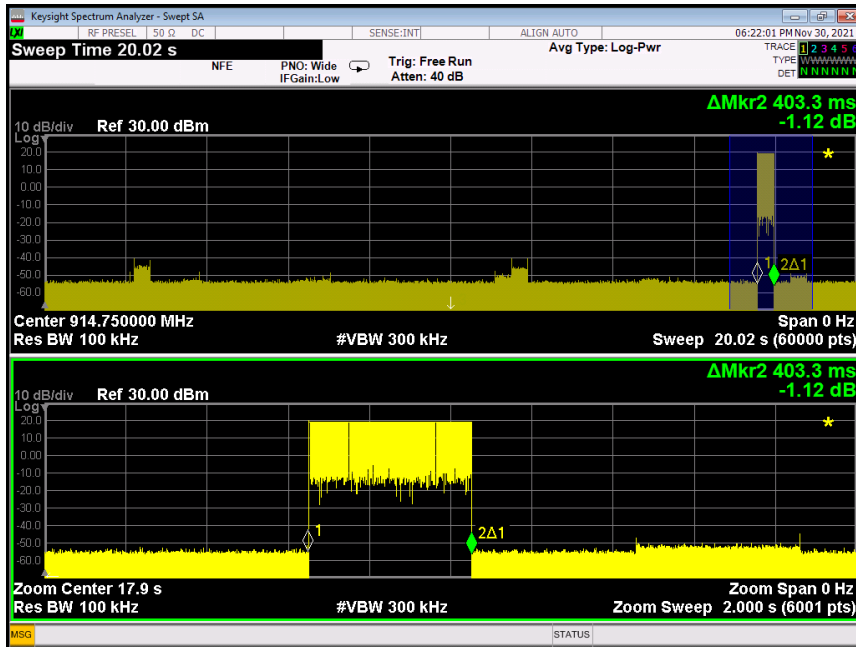

Dwell Time of Each Pulse [ms]	Average Cycle [S]	Average Time of Occupancy [ms]	Limit [ms]
403.3	20.22	398.91	<400

Note:
 Average Time of Occupancy = (Dwell Time of Each Pulse / Average cycle) x Specified Period
 Specified Period: 20S

5.6 Number of Hopping Frequency

5.6.1 Setting Remarks

The test was performed in accordance with ANSI C63.10 clause 7.8.3.
 The spectrum analyzer is set as following:

- Frequency Span : the frequency band of operation
- Resolution Bandwidth : 9 kHz
- Video Bandwidth : 100 kHz
- Detector Mode : Peak
- Trace Mode : Max Hold

5.6.2 Test Detail

Result: Passed

- Test operator : Junya Takashiba
- Date of testing : 2021-11-30
- Room temperature : 20 °C
- Relative humidity : 31 %

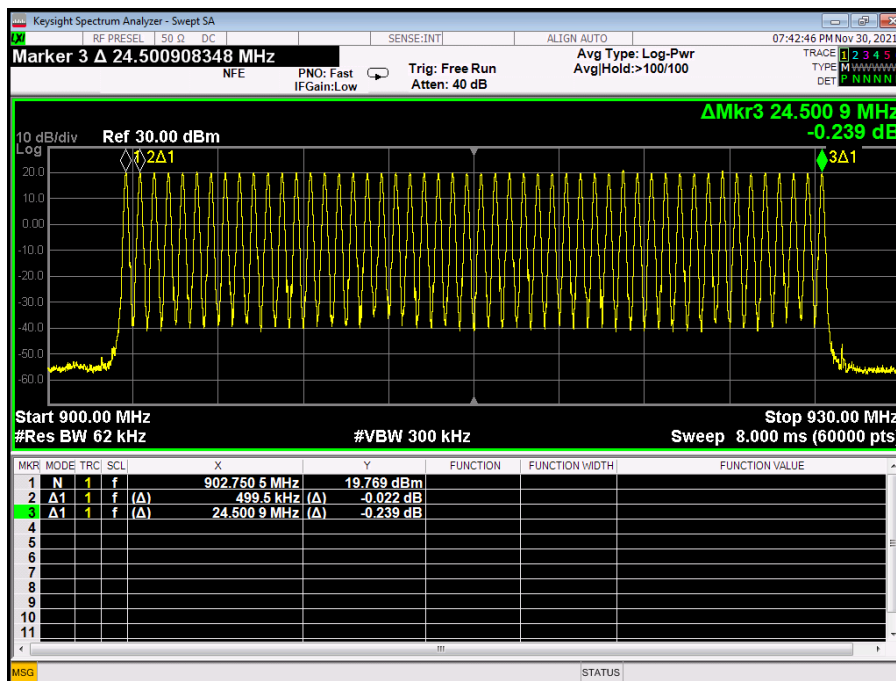

Number of Hopping Frequency	Limit
50	≥ 50

5.7 Maximum Peak Conducted Output Power and E.I.R.P.

5.7.1 Setting Remarks

The test was performed in accordance with ANSI C63.10 clause 7.8.5.

The spectrum analyzer is set as following:

·Frequency Span	: 1 MHz
·Resolution Bandwidth	: 300 kHz
·Video Bandwidth	: 1 MHz
·Detector Mode	: Peak
·Trace Mode	: Max Hold

5.7.2 Limit

For systems using digital modulation in the 902-928 MHz, 2400-2483.5 MHz and 5725-5850 MHz bands: 1 Watt.

5.7.3 Test Detail

Result: Passed

Uncertainty of measurement result	: ± 0.47 dB
Test operator	: Junya Takashiba
Date of testing	: 2021-11-15
Room temperature	: 23 °C
Relative humidity	: 43 %

5.7.3 Test Detail (Continued)

Sample Calculation

$$\begin{aligned} \text{Margin} &= \text{Limit} - \text{Peak Power} \\ &= 30 - (-29.39) \\ &= 0.61 \end{aligned}$$

Conducted Output Power (Battery Operation)

Frequency [MHz]	Reading [dBm]	c.f [dB]	Result [dBm]	Limit [dBm]	Margin [dB]
902.75	19.37	10.02	29.39	30	0.61
914.75	18.96	10.02	28.98	30	1.02
927.25	19.09	10.02	29.11	30	0.89

Conducted Output Power (on Charging)

Frequency [MHz]	Power Supply Voltage [V]	Reading [dBm]	c.f [dB]	Result [dBm]	Limit [dBm]	Margin [dB]
902.75	102	18.77	10.02	28.79	30	1.21
	120	18.88	10.02	28.9	30	1.1
	138	18.41	10.02	28.43	30	1.57
914.75	102	18.57	10.02	28.59	30	1.41
	120	18.91	10.02	28.93	30	1.07
	138	18.62	10.02	28.64	30	1.36
927.25	102	18.58	10.02	28.6	30	1.4
	120	18.96	10.02	28.98	30	1.02
	138	18.67	10.02	28.69	30	1.31

c.f (Correction Factor) = Cable Attenuation Factor + Attenuator Factor

5.7.3 Test Detail (Continued)

E.I.R.P (Battery Operation)

Frequency [MHz]	Conducted Power [dBm]	Antenna Gain [dBi]	E.I.R.P [dBm]	Limit [dBm]	Margin [dB]
902.75	29.39	2.97	32.36	36	3.64
914.75	28.98	2.97	31.95	36	4.05
927.25	29.11	2.97	32.08	36	3.92

E.I.R.P (on Charging)

Frequency [MHz]	Power Supply Voltage [V]	Conducted Power [dBm]	Antenna Gain [dBi]	E.I.R.P [dBm]	Limit [dBm]	Margin [dB]
902.75	102	28.79	2.97	31.76	36	4.24
	120	28.9	2.97	31.87	36	4.13
	138	28.43	2.97	31.4	36	4.6
914.75	102	28.59	2.97	31.56	36	4.44
	120	28.93	2.97	31.9	36	4.1
	138	28.64	2.97	31.61	36	4.39
927.25	102	28.6	2.97	31.57	36	4.43
	120	28.98	2.97	31.95	36	4.05
	138	28.69	2.97	31.66	36	4.34

5.8 Conducted Spurious Emission

5.8.1 Setting Remarks

The test was performed in accordance with ANSI C63.10 clause 6.7 and 7.8.8.

The Spectrums are scanned from the lowest generated frequency of EUT up to the 10th harmonics by using the spectrum analyzer.

The spectrum analyzer is set as following:

·Resolution Bandwidth	: 100 kHz
·Video Bandwidth	: 300 kHz
·Detector Mode	: Peak
·Trace Mode	: Max Hold

5.8.2 Limit

In any 100 kHz bandwidth outside the frequency band in which the spread spectrum or digitally modulated intentional radiator is operating, the radio frequency power that is produced by the intentional radiator shall be at least 20 dB below that in the 100 kHz bandwidth within the band that contains the highest level of the desired power, based on either an RF conducted or a radiated measurement, provided the transmitter demonstrates compliance with the peak conducted power limits.

5.8.3 Test Detail

Result: Passed

Uncertainty of measurement result	: ±1.38 dB
Test operator	: Junya Takashiba
Date of testing	: 2021-11-30
Room temperature	: 20 °C
Relative humidity	: 35 %

5.8.3 Test Detail (Continued)

<TX 1ch>

Fundamental Frequency	Frequency [MHz]	Relative Value [dBc]	Limit [dB]	Margin [dB]
902.75	463.29	-76.2	-20	56.2
	1805.51	-67.3	-20	47.3
	2708.31	-77.2	-20	57.2

Note:

It may be seen different from the value in the screen shot because the cable loss is corrected.

5.8.3 Test Detail (Continued)

Worst Test Data (Limit Level)

Worst Test Data
 <30 MHz to 3.6 GHz TX 1ch>

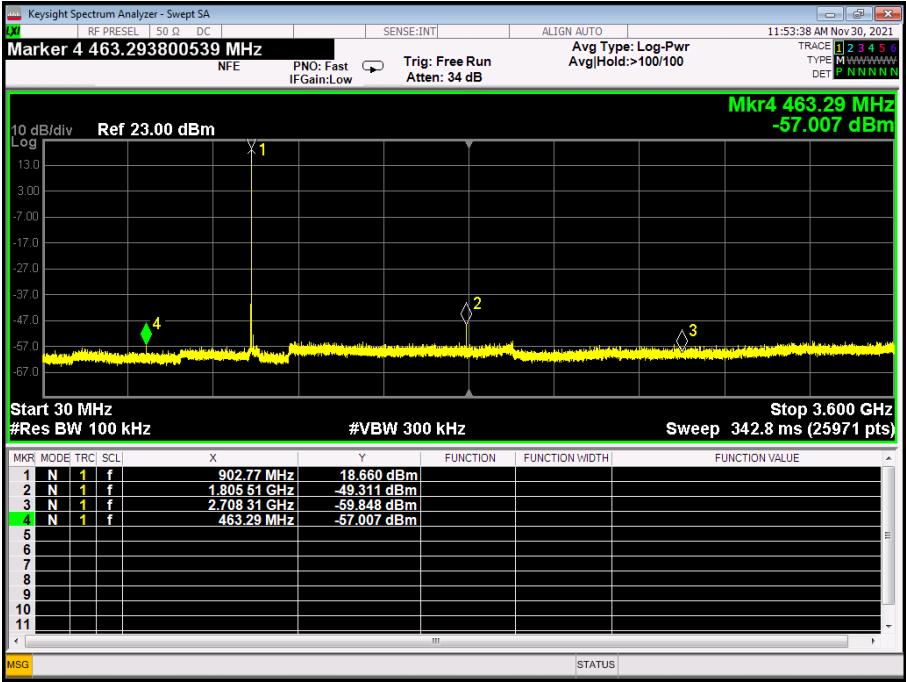

Worst Test Data
 <3.6 GHz to 26 GHz TX 1ch>

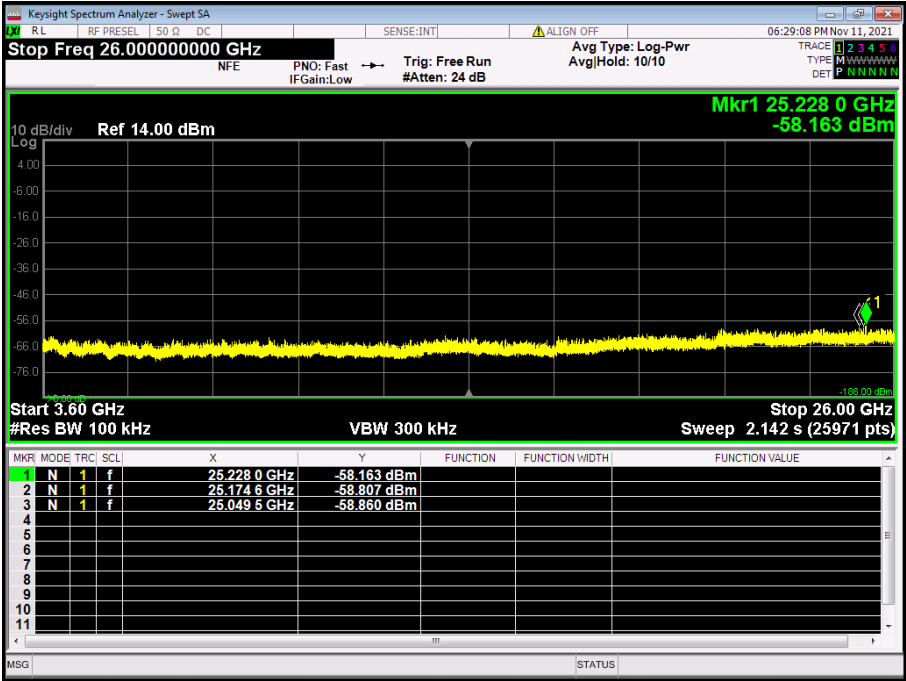

5.8.3 Test Detail (Continued)

<TX 25ch>

Fundamental Frequency	Frequency [MHz]	Relative Value [dBc]	Limit [dB]	Margin [dB]
914.75	807.1	-76.0	-20	56.0
	1829.43	-69.8	-20	49.8
	2744.2	-78.2	-20	58.2

Note:

It may be seen different from the value in the screen shot because the cable loss is corrected.

5.8.3 Test Detail (Continued)

Worst Test Data
 <30 MHz to 3.6 GHz TX 25ch>

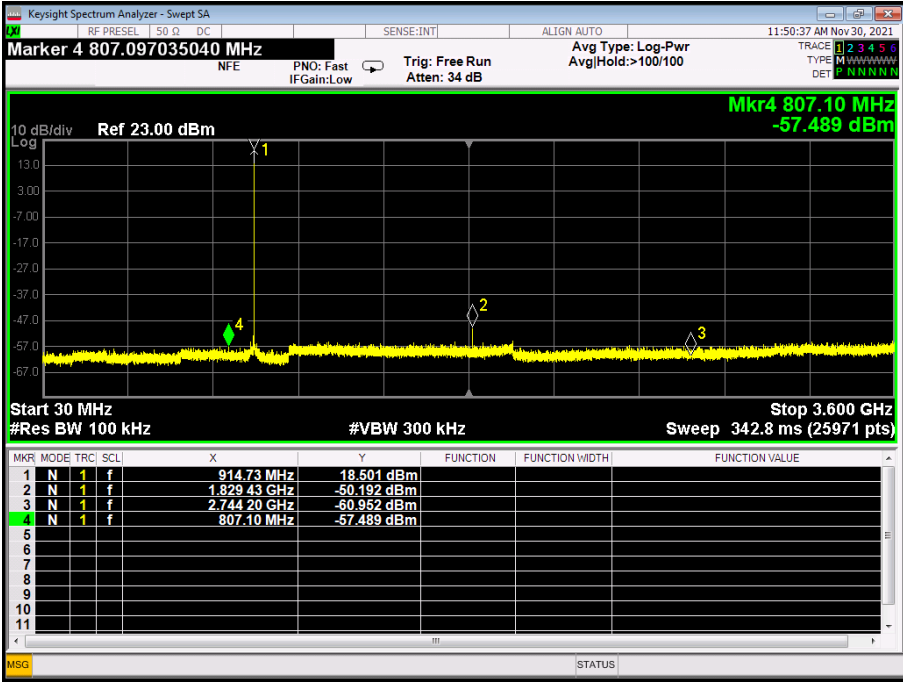

Worst Test Data
 <3.6 GHz to 26 GHz TX 25ch>

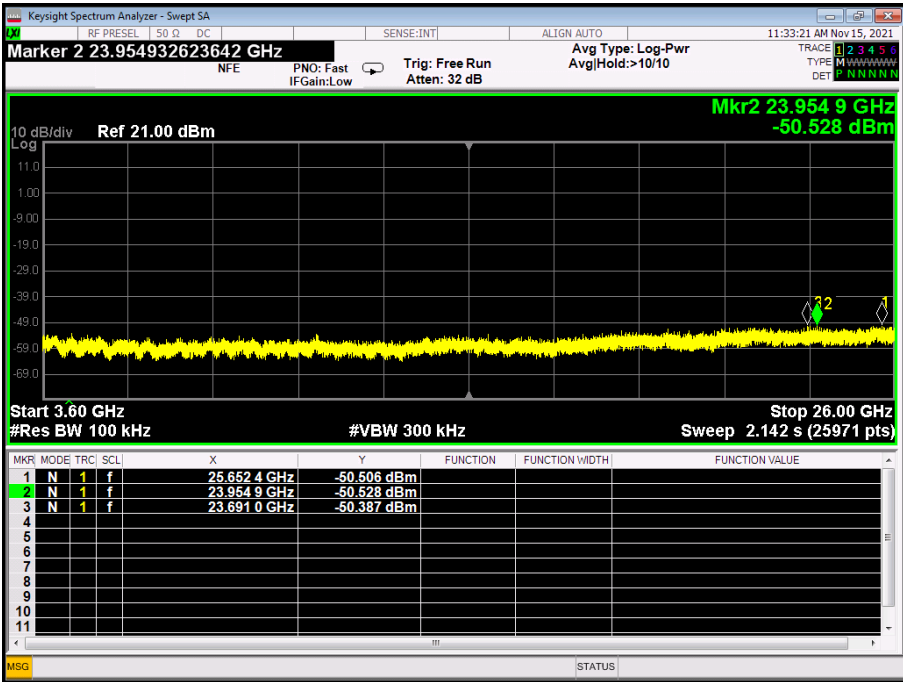

5.8.3 Test Detail (Continued)

<TX 50ch>

Fundamental Frequency	Frequency [MHz]	Relative Value [dBc]	Limit [dB]	Margin [dB]
927.25	1854.59	-69.4	-20	49.4
	2781.72	-76.1	-20	56.1

Note:

It may be seen different from the value in the screen shot because the cable loss is corrected.

5.8.3 Test Detail (Continued)

Worst Test Data
 <30 MHz to 3.6 GHz TX 50ch>

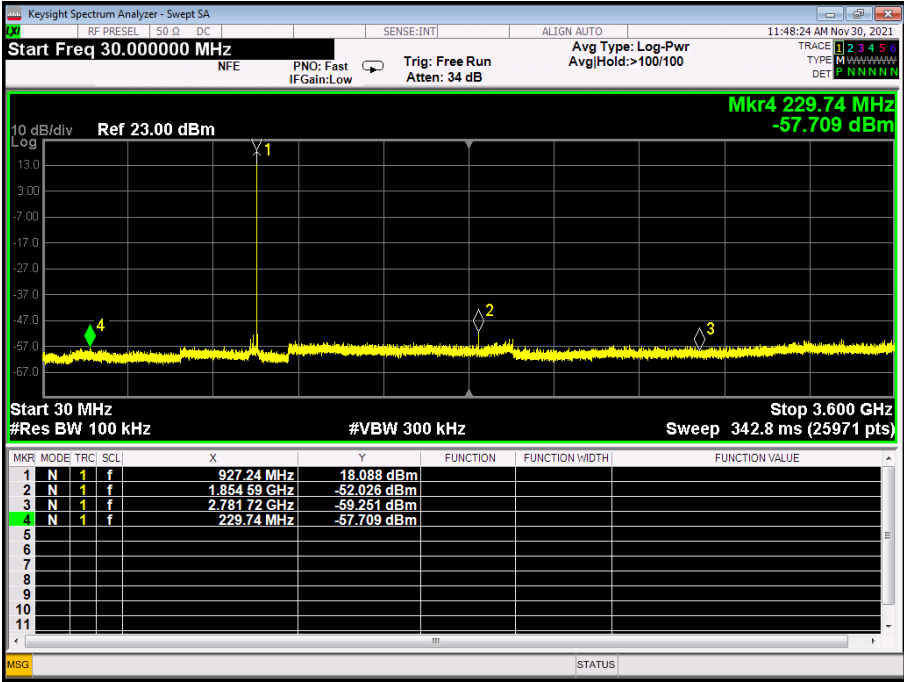

Worst Test Data
 <3.6 GHz to 26 GHz TX 50ch>

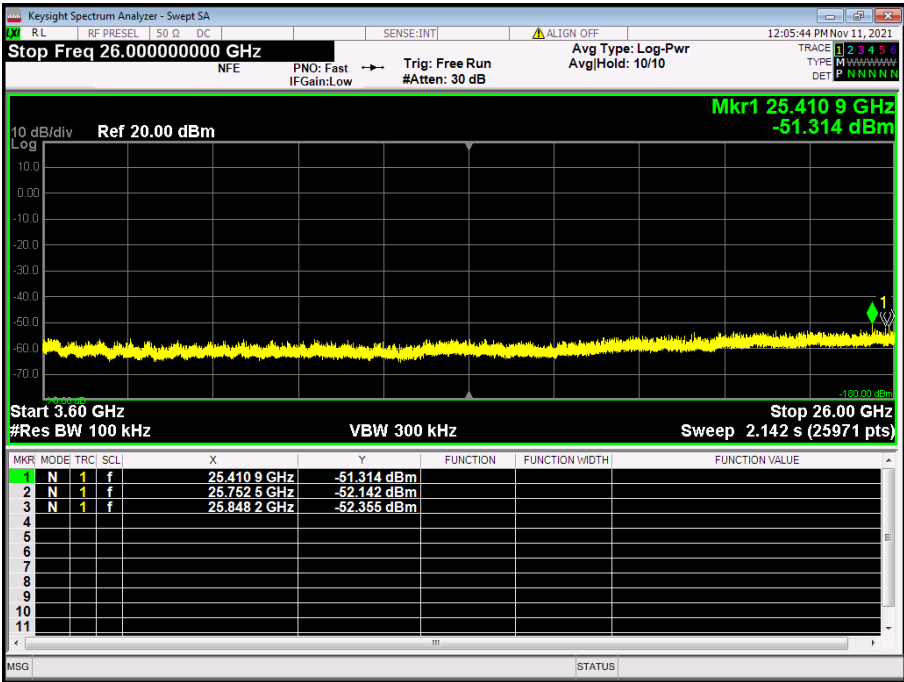

5.9 Band Edge Measurement

5.9.1 Setting Remarks

The test was performed in accordance with ANSI C63.10 clause 6.10.

The spectrum analyzer is set as following:

- Resolution bandwidth: 100 kHz
- Video bandwidth: 300 kHz
- Detector: Peak.
- Trace: Max hold.

5.9.2 Limit

In any 100 kHz bandwidth outside the frequency band in which the spread spectrum or digitally modulated intentional radiator is operating, the radio frequency power that is produced by the intentional radiator shall be at least 20 dB below that in the 100 kHz bandwidth within the band that contains the highest level of the desired power, based on either an RF conducted or a radiated measurement, provided the transmitter demonstrates compliance with the peak conducted power limits. If the transmitter complies with the conducted power limits based on the use of RMS averaging over a time interval, as permitted under of this section, the attenuation required under this paragraph shall be 30 dB instead of 20 dB.

5.9.3 Test Detail

Result: Passed

Uncertainty of measurement result	: ±1.38 dB
Test operator	: Junya Takashiba
Date of testing	: 2021-11-15
Room temperature	: 25 °C
Relative humidity	: 42 %

5.9.3 Test Detail (Continued)

Test Data

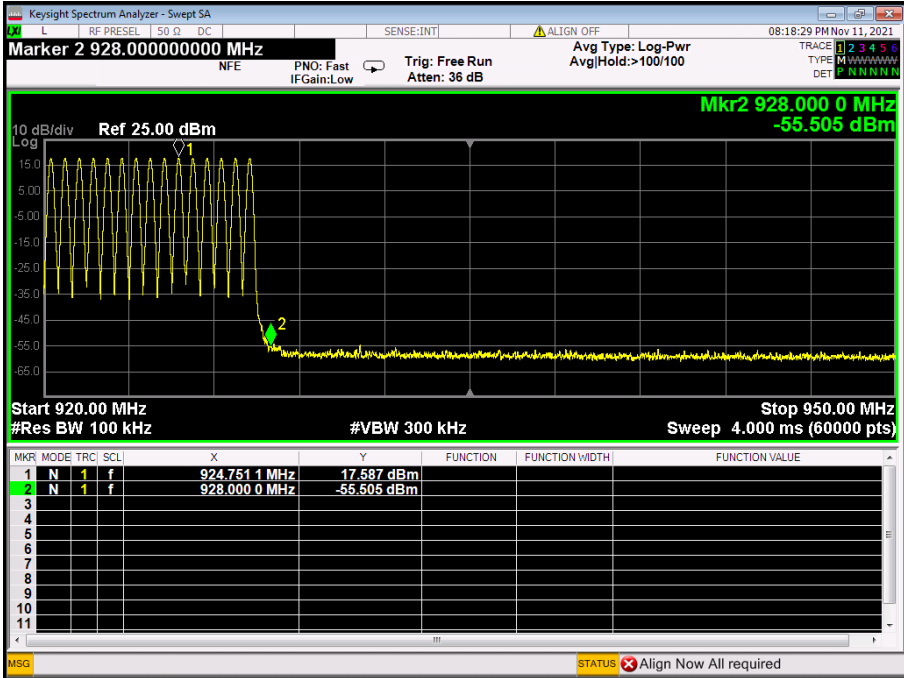
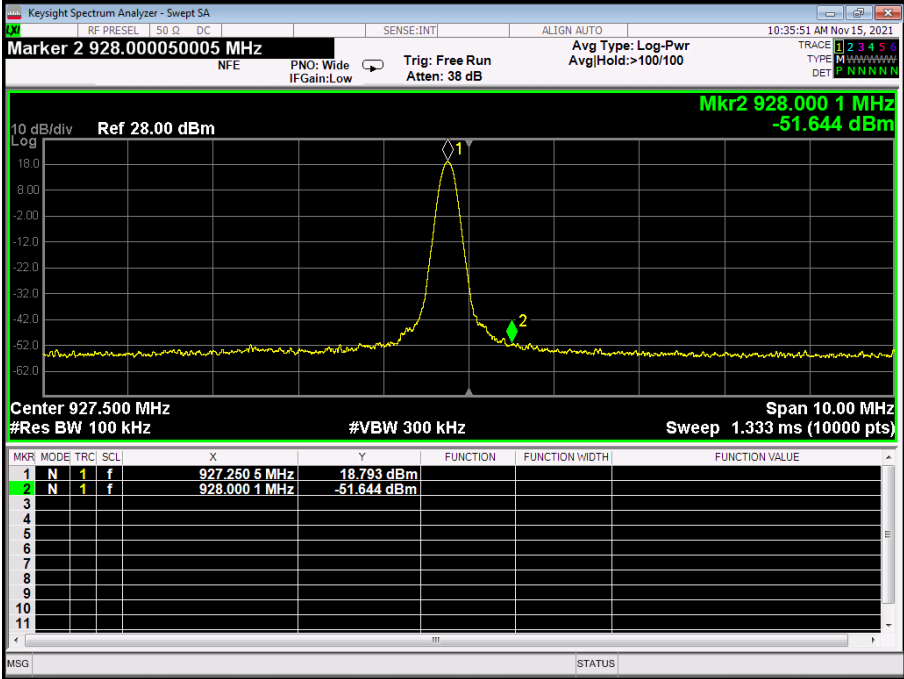

5.9.3 Test Detail (Continued)

Test Data

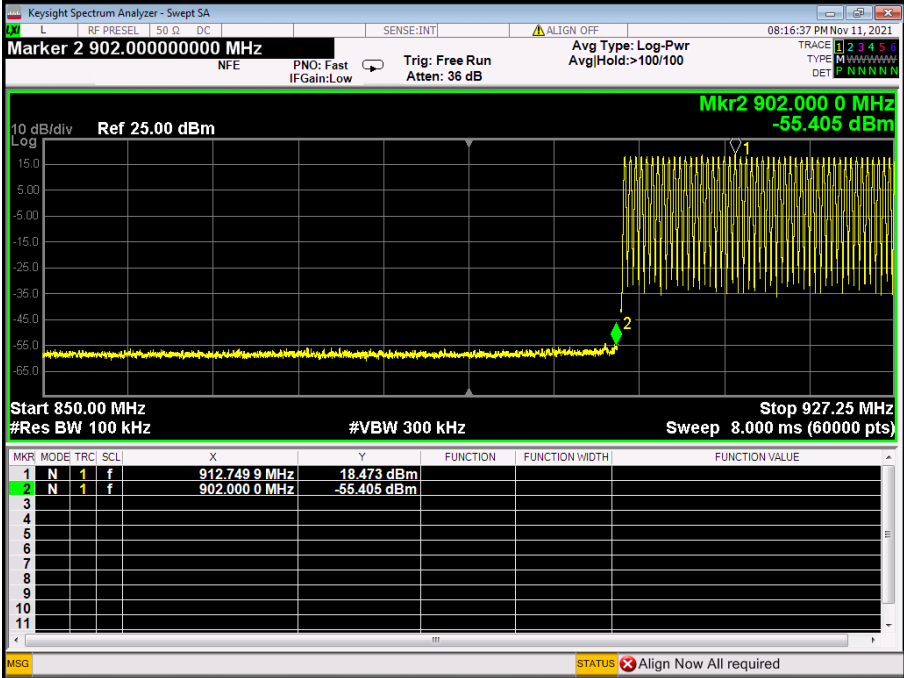
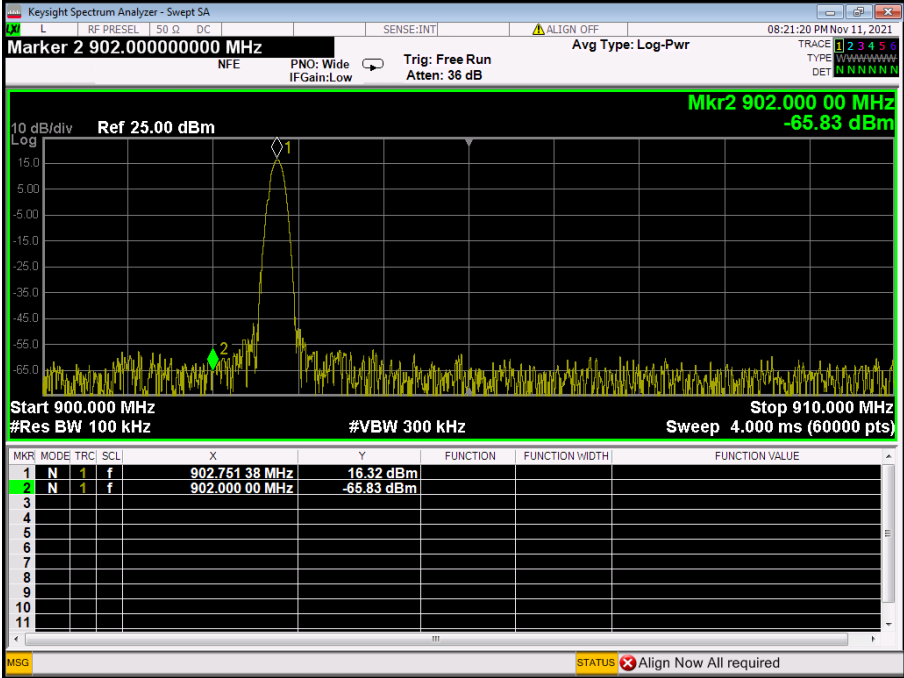

5.10 Occupied Bandwidth (RSS-Gen Annex A)

5.10.1 Setting Remarks

The test was performed in accordance with ANSI C63.10 clause 6.9.3.
Occupied Bandwidth is measured by using 99% Bandwidth measurement function.
The spectrum analyzer is set as following:

- Resolution Bandwidth : 3 kHz
- Video Bandwidth : 9 kHz
- Detector Mode : Peak
- Trace Mode : Max Hold

5.10.2 Test Detail

Result: Passed

- Measurement instrumentation uncertainty : ± 0.025 %
- Test operator : Junya Takashiba
- Date of testing : 2021-11-25
- Room temperature : 20 °C
- Relative humidity : 25 %

Test Data

Frequency [MHz]	Measured Bandwidth [kHz]
902.75	66.648
914.75	69.006
927.25	69.629

5.10.2 Test Detail (Continued)

Test Data (1ch)

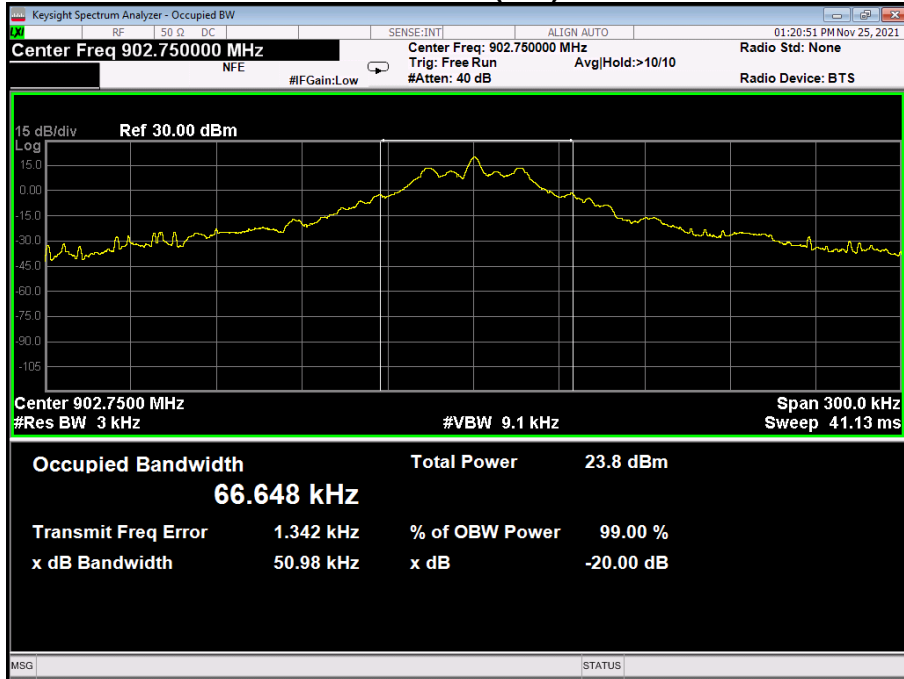

Test Data (25ch)

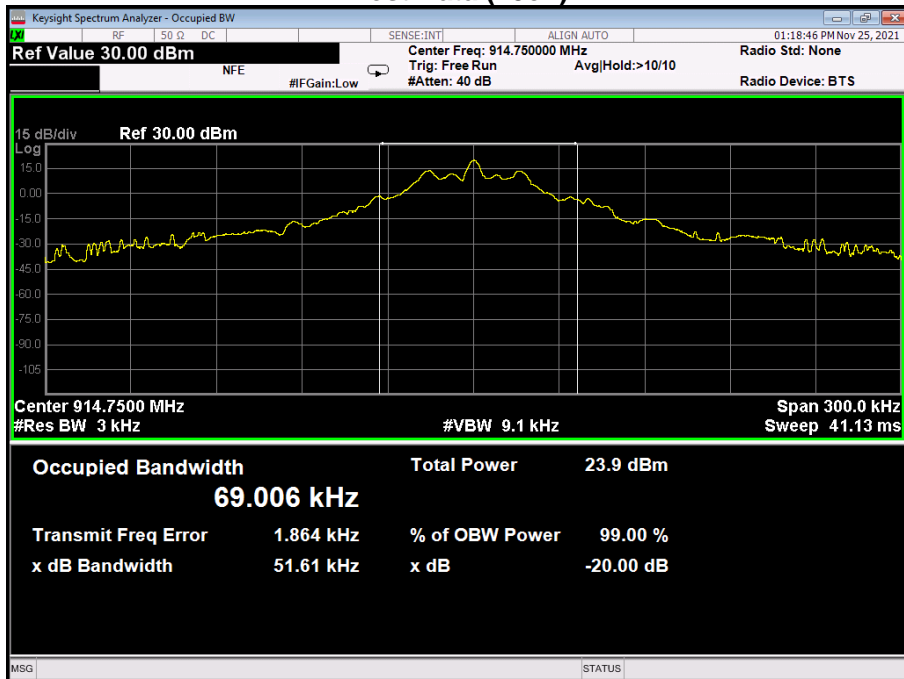

5.10.2 Test Detail (Continued)

Test Data (50ch)

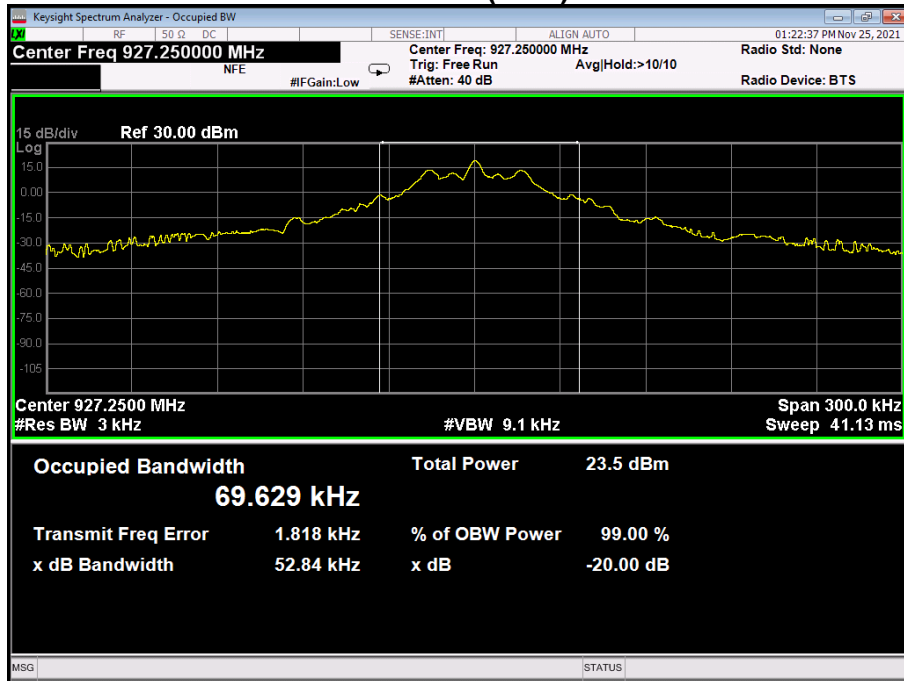

6. List of Test and Measurement Instruments

AC Power Line Conducted Emission

Instruments	Manufacturer	Model	Serial No.	Calibrated Date/Until
EMI Test Receiver	Agilent Technologies	N9038A	MY54130015	2021-03-15 2022-03-14
Artificial Mains Network	Kyoritsu	KNW-407F	8-2035-3	2021-09-15 2022-09-14
Shielded Room	JSE	COSR-01	---	---
RF Cable (9 kHz to 30 MHz)	Fujikura SUHFNER	OSEMICES1	OC01 OC02 OC04	2021-03-17 2022-03-16
Software	TOYO	EP5/CE (ver 5.4.40)	--	---
Electronic Thermometer Hygrometer	A & D	AD-5682	0311/10120	2021-08-03 2022-08-02
Barometer	Sato Keiryoki Mfg.	7610-20	87812	2020-11-24 2023-11-23

6. List of Test and Measurement Instruments (Continued)

Transmitter Spurious Emissions (Radiated) (Below 1 GHz)

Instruments	Manufacturer	Model	Serial No.	Calibrated Date/Until
EMI Test Receiver	Agilent Technologies	N9038A	MY54130015	2021-03-15 2022-03-14
Pre-Amplifier (30 MHz to 1 GHz)	HEWLETT PACKARD	8447D OPT 010	2944A07891	2021-05-19 2022-05-18
Biconical Antenna (30 MHz to 300 MHz)	SCHWARZBECK	VHA9103 BBA9106	08092 0450	2021-09-03 2022-09-02
Log-Periodic Antenna (300 MHz to 1 GHz)	SCHWARZBECK	VUSLP9111B	VUSLP9111B #295	2021-09-08 2022-09-07
Attenuator 3 dB	JFW Industries	50FP-003-H2	---	2021-05-14 2022-05-13
RF Cable RF Selector (30 MHz to 1 GHz)	Fujikura	8D-2W	OC14	2021-03-16 2022-03-15
	SUHNER	RG223/U	OC11	
		RG214/U	OC15 OC16	
		RG400/U	OC17	
	TSJ	RFM-E121	03149	
Anechoic Chamber 3 m	JSE	COAC3M-01	---	2021-10-20 2022-10-19
Software	TOYO	EP5/RE (ver 5.7.1)	--	---
Electronic Thermometer Hygrometer	A & D	AD-5682	0311/10120	2021-08-03 2022-08-02
Barometer	Sato Keiryoki Mfg.	7610-20	87812	2020-11-24 2023-11-23

6. List of Test and Measurement Instruments (Continued)

Transmitter Spurious Emission (Radiated) (Above 1 GHz)

Instruments	Manufacturer	Model	Serial No.	Calibrated Date/Until
EMI Test Receiver	Agilent Technologies	N9038A	MY54130015	2021-03-15 2022-03-14
Pre-Amplifier	TSJ	MLA-0120AML -34	(OE00060S)	2021-09-09 2022-09-08
Double Ridged Broadband Horn Antenna (1 GHz to 8.2 GHz)	ETS LINDGREN	3117	00146461	2020-08-31 2022-08-30
Standard Gain Horn Antenna (8.2 GHz to 12.4 GHz)	MI Technologies	12-8.2 093290	22856NL	2020-12-17 2021-12-16
Attenuator 10 dB	JFW Industries	50HF-010N	1324	2021-10-07 2022-10-06
Anechoic Chamber 3 m	JSE	COAC3M-01	---	2021-10-20 2022-10-19
RF Cable (1 GHz to 18 GHz)	STORM	TRUE BLUE 290	OC18 OC19 OC20	2021-03-19 2022-03-18
Software	TOYO	EP5/RE (ver 5.7.1)	--	---
Electronic Thermometer Hygrometer	A & D	AD-5682	0311/10120	2021-08-03 2022-08-02
Barometer	Sato Keiryoki Mfg.	7610-20	87812	2020-11-24 2023-11-23

6. List of Test and Measurement Instruments (Continued)

**20 dB Bandwidth / Carrier Frequency Separation / Number of Hopping Frequency /
 Average Time of Occupancy / Maximum Peak Conducted Output Power and E.I.R.P. /
 Conducted Spurious Emission / Band Edge Measurement / Occupied Bandwidth**

Instruments	Manufacturer	Model	Serial No.	Calibrated Date/Until
EMI Test Receiver	Agilent Technologies	N9038A	MY54130015	2021-03-15 2022-03-14
RF TEST SET	Agilent Technologies (MORITA TECH Co., Ltd)	MT-747	13326	2021-10-11 2022-10-10
RF Cable	HUBER + SUHNER	SUCOFULEX 102	OC30 OC34	2021-10-11 2022-10-10
Software	KEYSIGHT TECHNOLOGIES	JPJ5A1NN14100 (Ver 1.60)	---	---
Electronic Thermometer Hygrometer	A & D	AD-5682	0311/10120	2021-08-03 2022-08-02
Barometer	Sato Keiryoki Mfg.	7610-20	87812	2020-11-24 2023-11-23

7. Appendix

Refer to separated files for the following appendixes.

Appendix 1: Photographs of the Test Setup

Appendix 2: External Photographs

----- End of Report -----