



RADIO TEST REPORT

Test Report No. : 11047825H-A-R1

Applicant : KEYENCE CORPORATION
Type of Equipment : Communication Unit
Model No. : HR-UC1
FCC ID : RF41399B
Test regulation : FCC Part 15 Subpart C: 2015
Test Result : Complied

1. This test report shall not be reproduced in full or partial, without the written approval of UL Japan, Inc.
2. The results in this report apply only to the sample tested.
3. This sample tested is in compliance with the above regulation.
4. The test results in this report are traceable to the national or international standards.
5. This test report must not be used by the customer to claim product certification, approval, or endorsement by NVLAP, NIST, or any agency of the Federal Government.
6. This test report covers Radio technical requirements. It does not cover administrative issues such as Manual or non-Radio test related Requirements. (if applicable)
7. This report is a revised version of 11047825H-A. 11047825H-A is replaced with this report.

Date of test: November 12 and 13, 2015

Representative test engineer: 
Takumi Shimada
Engineer
Consumer Technology Division

Approved by: 
Takayuki Shimada
Engineer
Consumer Technology Division

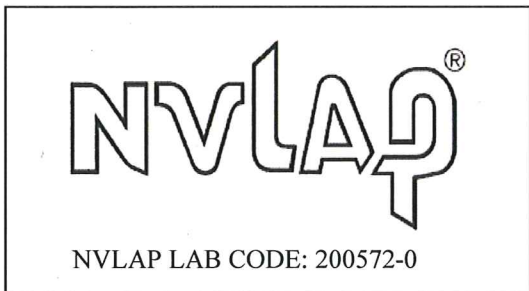

This laboratory is accredited by the NVLAP LAB CODE 200572-0, U.S.A. The tests reported herein have been performed in accordance with its terms of accreditation. *As for the range of Accreditation in NVLAP, you may refer to the WEB address, http://japan.ul.com/resources/emc_accredited/

CONTENTS	PAGE
SECTION 1: Customer information.....	4
SECTION 2: Equipment under test (E.U.T.).....	4
SECTION 3: Test specification, procedures & results.....	5
SECTION 4: Operation of E.U.T. during testing.....	8
SECTION 5: Conducted Emission.....	10
SECTION 6: Radiated Spurious Emission	11
SECTION 7: Antenna Terminal Conducted Tests.....	12
APPENDIX 1: Test data	13
Conducted Emission	13
20dB Bandwidth and Carrier Frequency Separation.....	15
Number of Hopping Frequency	17
Dwell time.....	19
Maximum Peak Output Power	21
Average Output Power	22
Radiated Spurious Emission	23
Conducted Spurious Emission	29
Conducted Emission Band Edge compliance	35
99%Occupied Bandwidth	36
APPENDIX 2: Test instruments	38
APPENDIX 3: Photographs of test setup	39
Conducted Emission	39
Radiated Spurious Emission	40
Worst Case Position (Horizontal: With Reader / Vertical: With Reader).....	41

SECTION 1: Customer information

Company Name : KEYENCE CORPORATION
Address : 1-3-14, Higashinakajima Higashiyodogawa-ku, Osaka 533-8555 Japan
Telephone Number : +81-6-6379-1197
Facsimile Number : +81-6-6325-6818
Contact Person : Kazuhiko Morishita

***Remarks:**

KEYENCE CORPORATION designates METRO (SUZHOU) TECHNOLOGIES CO LTD as manufacturer of the product (Communication Unit).

SECTION 2: Equipment under test (E.U.T.)

2.1 Identification of E.U.T.

Type of Equipment : Communication Unit
Model No. : HR-UC1
Serial No. : Refer to Section 4, Clause 4.2
Rating : DC 4.5 V to 5.5 V
Receipt Date of Sample : November 12, 2015
Country of Mass-production : China
Condition of EUT : Engineering prototype
(Not for Sale: This sample is equivalent to mass-produced items.)
Modification of EUT : No Modification by the test lab

2.2 Product Description

Model: HR-UC1 (referred to as the EUT in this report) is a Communication Unit.

General Specification

Clock frequency(ies) in the system : Crystal: 26 MHz
CPU: 266 MHz
Memory : 133 MHz
Y2 : 26 MHz
Y3 : 24 MHz
USB : 12 MHz
Power supplies : 1.6 MHz
Y1 : 32.768 KHz

Radio Specification

[Bluetooth (Ver. 2.1 without EDR function)]

Radio Type : Transceiver
Frequency of Operation : 2402 MHz - 2480 MHz
Modulation : FHSS
Power Supply (radio part input) : DC 3.3 V
Antenna type : MULLTILAYER CHIP ANTENNA
Antenna Gain : 2 dBi (Peak)

UL Japan, Inc.

Ise EMC Lab.

4383-326 Asama-cho, Ise-shi, Mie-ken 516-0021 JAPAN

Telephone : +81 596 24 8999

Facsimile : +81 596 24 8124

SECTION 3: Test specification, procedures & results

3.1 Test Specification

Test Specification : FCC Part 15 Subpart C: 2015, final revised on November 23, 2015
*Some parts are effective on and after December 17, 2015 or December 23, 2015. The revision does not affect the test specification applied to the EUT.

Title : FCC 47CFR Part15 Radio Frequency Device Subpart C Intentional Radiators
Section 15.207 Conducted limits
Section 15.247 Operation within the bands 902-928MHz,
2400-2483.5MHz, and 5725-5850MHz

3.2 Procedures and results

Item	Test Procedure	Specification	Worst Margin	Results	Remarks
Conducted Emission	FCC: ANSI C63.4-2009 7. AC powerline conducted emission measurements IC: RSS-Gen 8.8	FCC: Section 15.207 IC: RSS-Gen 8.8	QP 13.7 dB, 0.65201 MHz, N AV 7.8 dB, 0.65105 MHz, L	Complied	-
Carrier Frequency Separation	FCC: FCC Public Notice DA 00-705 IC: -	FCC: Section15.247(a)(1) IC: RSS-247 5.1 (2)	See data.	Complied	Conducted
20dB Bandwidth	FCC: FCC Public Notice DA 00-705 IC: -	FCC: Section15.247(a)(1) IC: RSS-247 5.1 (1)		Complied	Conducted
Number of Hopping Frequency	FCC: FCC Public Notice DA 00-705 IC: -	FCC: Section15.247(a)(1)(iii) IC: RSS-247 5.1 (4)		Complied	Conducted
Dwell time	FCC: FCC Public Notice DA 00-705 IC: -	FCC: Section15.247(a)(1)(iii) IC: RSS-247 5.1 (4)		Complied	Conducted
Maximum Peak Output Power	FCC: FCC Public Notice DA 00-705 IC: RSS-Gen 6.12	FCC: Section15.247(a)(b)(1) IC: RSS-247 5.4 (2)		Complied	Conducted
Spurious Emission & Band Edge Compliance	FCC: FCC Public Notice DA 00-705 IC: RSS-Gen 6.13	FCC: Section15.247(d) IC: RSS-247 5.5 RSS-Gen 8.9 RSS-Gen 8.10		3.5 dB 532.002 MHz, QP, Horizontal.	Complied

Note: UL Japan, Inc.'s EMI Work Procedures No. 13-EM-W0420 and 13-EM-W0422.

*1) Radiated test was selected over 30 MHz based on section 15.247(d).

* In case any questions arise about test procedure, ANSI C63.4: 2009 is also referred.

FCC Part 15.31 (e)

This EUT provides stable voltage(DC3.3 V) constantly to RF Module regardless of input voltage. Therefore, this EUT complies with the requirement.

FCC Part 15.203 Antenna requirement

It is impossible for end users to replace the antenna, because the antenna is mounted inside of the EUT. Therefore, the equipment complies with the antenna requirement of Section 15.203.

UL Japan, Inc.

Ise EMC Lab.

4383-326 Asama-cho, Ise-shi, Mie-ken 516-0021 JAPAN

Telephone : +81 596 24 8999

Facsimile : +81 596 24 8124

3.3 Addition to standard

Item	Test Procedure	Specification	Worst margin	Results	Remarks
99% Occupied Bandwidth	IC: RSS-Gen 6.6	IC: -	N/A	-	Conducted

Other than above, no addition, exclusion nor deviation has been made from the standard.

3.4 Uncertainty

EMI

The following uncertainties have been calculated to provide a confidence level of 95 % using a coverage factor $k = 2$.
Ise EMC Lab.

Test site (semi anechoic chamber)	Conducted emission Uncertainty (+/-)			
	No. 1	No. 2	No. 3	No. 4
150 kHz - 30 MHz	3.5 dB	3.5 dB	3.4 dB	3.5 dB

Test site (semi anechoic chamber)	Radiated emission Uncertainty (+/-)						
	Measurement distance: 3 m				1 m		0.5 m
	9 kHz - 30 MHz	30 MHz - 300 MHz	300 MHz - 1 GHz	1 GHz - 10 GHz	10 GHz - 18 GHz	18 GHz - 26.5 GHz	26.5 GHz - 40 GHz
No. 1	4.3 dB	5.1 dB	6.2 dB	5.5 dB	5.8 dB	5.8 dB	4.3 dB
No. 2	4.2 dB	5.1 dB	6.2 dB	5.4 dB	5.7 dB	5.9 dB	5.6 dB
No. 3	4.4 dB	5.1 dB	6.3 dB	5.2 dB	5.5 dB	5.8 dB	5.5 dB
No. 4	4.7 dB	5.3 dB	6.3 dB	5.3 dB	5.7 dB	5.9 dB	5.5 dB

Antenna terminal test Uncertainty (+/-)							
Power meter		Conducted emission and Power density			Conducted emission		Channel power
Below 1 GHz	Above 1 GHz	Below 1 GHz	1 GHz - 3 GHz	3 GHz - 18 GHz	18 GHz - 26.5 GHz	26.5 GHz - 40 GHz	
0.9 dB	1.0 dB	1.4 dB	1.7 dB	2.8 dB	2.8 dB	2.9 dB	2.6 dB

Conducted Emission test

The data listed in this test report has enough margin, more than the site margin.

Radiated emission test

The data listed in this report meets the limits unless the uncertainty is taken into consideration.

3.5 Test Location

UL Japan, Inc. Ise EMC Lab. *NVLAP Lab. code: 200572-0
 4383-326 Asama-cho, Ise-shi, Mie-ken 516-0021 JAPAN
 Telephone: +81 596 24 8999, Facsimile: +81 596 24 8124

Test site	IC Registration Number	Width x Depth x Height (m)	Size of reference ground plane (m) / horizontal conducting plane	Other rooms	Maximum measurement distance
No.1 semi-anechoic chamber	2973C-1	19.2 x 11.2 x 7.7	7.0 x 6.0	No.1 Power source room	10 m
No.2 semi-anechoic chamber	2973C-2	7.5 x 5.8 x 5.2	4.0 x 4.0	-	3 m
No.3 semi-anechoic chamber	2973C-3	12.0 x 8.5 x 5.9	6.8 x 5.75	No.3 Preparation room	3 m
No.3 shielded room	-	4.0 x 6.0 x 2.7	N/A	-	-
No.4 semi-anechoic chamber	2973C-4	12.0 x 8.5 x 5.9	6.8 x 5.75	No.4 Preparation room	3 m
No.4 shielded room	-	4.0 x 6.0 x 2.7	N/A	-	-
No.5 semi-anechoic chamber	-	6.0 x 6.0 x 3.9	6.0 x 6.0	-	-
No.6 shielded room	-	4.0 x 4.5 x 2.7	4.0 x 4.5	-	-
No.6 measurement room	-	4.75 x 5.4 x 3.0	4.75 x 4.15	-	-
No.7 shielded room	-	4.7 x 7.5 x 2.7	4.7 x 7.5	-	-
No.8 measurement room	-	3.1 x 5.0 x 2.7	N/A	-	-
No.9 measurement room	-	8.8 x 4.6 x 2.8	2.4 x 2.4	-	-
No.11 measurement room	-	6.2 x 4.7 x 3.0	4.8 x 4.6	-	-

* Size of vertical conducting plane (for Conducted Emission test) : 2.0 m x 2.0 m for No.1, No.2, No.3, and No.4 semi-anechoic chambers and No.3 and No.4 shielded rooms.

3.6 Test data, Test instruments, and Test set up

Refer to APPENDIX.

SECTION 4: Operation of E.U.T. during testing

4.1 Operating Mode(s)

Bluetooth (BT): Transmitting (Tx), Payload: PRBS9

Details of Operating Mode(s)

Test Item	Mode	Tested frequency
Conducted Emission, Spurious Emission (Conducted/Radiated)	Tx (Hopping Off) DH5	2402 MHz 2441 MHz 2480 MHz
Carrier Frequency Separation	Tx (Hopping On) DH5	2402 MHz 2441 MHz 2480 MHz
20dB Bandwidth	Tx (Hopping Off) DH5	2402 MHz 2441 MHz 2480 MHz
Number of Hopping Frequency	Tx (Hopping On) DH5	-
Dwell time	Tx (Hopping On), -DH1, DH3, DH5	-
Maximum Peak Output Power	Tx (Hopping Off) DH5	2402 MHz 2441 MHz 2480 MHz
Band Edge Compliance (Conducted)	Tx DH5 -Hopping On -Hopping Off	2402 MHz 2480 MHz
99% Occupied Bandwidth	Tx DH5 -Hopping On -Hopping Off	2402 MHz 2441 MHz 2480 MHz
<p>*As a result of preliminary test, the formal test was performed with the above modes, which had the maximum payload length (except Dwell time test)</p> <p>*2DH mode (2Mb/s EDR: pi/4DQPSK) was excluded for other tests than power measurement by using 3DH mode (3 Mb/s EDR: 8DPSK) as a representative.</p> <p>* It is considered that the non-tested packet type (e.g. inquiry) can be omitted as it is complied with above all test items based on Bluetooth Core specification.</p> <p>*EUT has the power settings by the software as follows; Power settings: same as production model Software: BK000253BBA.Nov.8.2015</p> <p>*This setting of software is the worst case. Any conditions under the normal use do not exceed the condition of setting. In addition, end users cannot change the settings of the output power of the product.</p>		

4.2 Configuration and peripherals

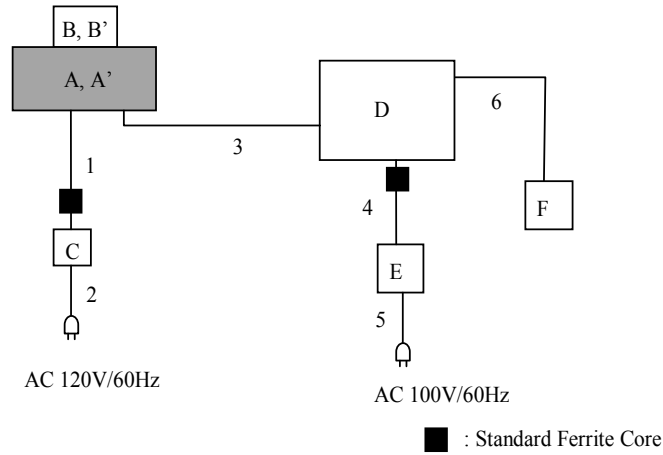

* Cabling and setup(s) were taken into consideration and test data was taken under worse case conditions.

Description of EUT and Support equipment

No.	Item	Model number	Serial number	Manufacturer	Remarks
A	Communication Unit	HR-UC1	15209B0720	METRO (SUZHOU) TECHNOLOGIES CO LTD	EUT
A'	Communication Unit	HR-UC1	UC18	METRO (SUZHOU) TECHNOLOGIES CO LTD	EUT *1)
B	Handheld Code Reader	HR-100B	15239B4C16	METRO (SUZHOU) TECHNOLOGIES CO LTD	-
B'	Handheld Code Reader	HR-100B	15236132E0D	METRO (SUZHOU) TECHNOLOGIES CO LTD	-
C	AC adapter	OP-88046	001	KEYENCE	-
D	Laptop PC	FMVNAGHM	R2X00554	FUJITSU	-
E	AC adapter	ADP-65JH ABZ	CP500581-01	FUJITSU	-
F	Mouse	M-MTURBK/RS	18015353C	ELECOM	-

*1) Used for Antenna Terminal conducted test

List of cables used

No.	Name	Length (m)	Shield		Remarks
			Cable	Connector	
1	DC Cable	1.6	Unshielded	Unshielded	-
2	AC Cable	2.0	Unshielded	Unshielded	-
3	RS-232C Cable	1.5	Unshielded	Unshielded	-
4	DC Cable	1.8	Unshielded	Unshielded	-
5	AC Cable	1.0	Unshielded	Unshielded	-
6	Mouse Cable	1.5	Unshielded	Unshielded	-

UL Japan, Inc.

Ise EMC Lab.

4383-326 Asama-cho, Ise-shi, Mie-ken 516-0021 JAPAN

Telephone : +81 596 24 8999

Facsimile : +81 596 24 8124

SECTION 5: Conducted Emission

Test Procedure and conditions

EUT was placed on a urethane platform of nominal size, 1.0 m by 1.5 m, raised 0.8m above the conducting ground plane.

The rear of tabletop was located 40 cm to the vertical conducting plane. The rear of EUT, including peripherals aligned and flushed with rear of tabletop. All other surfaces of tabletop were at least 80 cm from any other grounded conducting surface. EUT was located 80 cm from a Line Impedance Stabilization Network (LISN) / Artificial mains Network (AMN) and excess AC cable was bundled in center.

For the tests on EUT with other peripherals

I/O cables that were connected to the peripherals were bundled in center. They were folded back and forth forming a bundle 30 cm to 40 cm long and were hanged at a 40 cm height to the ground plane. All unused 50 ohm connectors of the LISN (AMN) were resistivity terminated in 50 ohm when not connected to the measuring equipment.

The AC Mains Terminal Continuous disturbance Voltage has been measured with the EUT in a Semi Anechoic Chamber.

The EUT was connected to a LISN (AMN).

An overview sweep with peak detection has been performed.

The test results and limit are rounded off to one decimal place, so some differences might be observed.

Detector : QP and CISPR AV
Measurement range : 0.15 MHz - 30 MHz
Test data : APPENDIX
Test result : Pass

SECTION 6: Radiated Spurious Emission

Test Procedure

EUT was placed on a urethane platform of nominal size, 1.0 m by 1.5 m, raised 0.8 m above the conducting ground plane.

The Radiated Electric Field Strength has been measured in a Semi Anechoic Chamber with a ground plane.

The height of the measuring antenna varied between 1 m and 4 m and EUT was rotated a full revolution in order to obtain the maximum value of the electric field strength.

The measurements were performed for both vertical and horizontal antenna polarization with the Test Receiver, or the Spectrum Analyzer.

The measurements were made with the following detector function of the test receiver and the Spectrum analyzer (in linear mode).

The test was made with the detector (RBW/VBW) in the following table.

When using Spectrum analyzer, the test was made with adjusting span to zero by using peak hold.

Test Antennas are used as below;

Frequency	30 MHz to 300 MHz	300 MHz to 1 GHz	Above 1 GHz
Antenna Type	Biconical	Logperiodic	Horn

In any 100 kHz bandwidth outside the restricted band in which the spread spectrum intentional radiator is operating, the radio frequency power that is produced by the intentional radiator confirmed 20 dB below that in the 100 kHz bandwidth within the band that contains the highest level of the desired power, based on a radiated measurement.

20 dBc was applied to the frequency over the limit of FCC 15.209 / Table 4 of RSS-Gen 8.9 (IC) and outside the restricted band of FCC15.205 / Table 6 of RSS-Gen 8.10 (IC).

Frequency	Below 1 GHz	Above 1 GHz		20 dBc
Instrument used	Test Receiver	Spectrum Analyzer		Spectrum Analyzer
Detector	QP	PK	AV	PK
IF Bandwidth	BW 120 kHz	RBW: 1 MHz VBW: 3 MHz	RBW: 1 MHz VBW: 10 Hz *1)	RBW: 100 kHz VBW: 300 kHz
Test Distance	3 m	3 m (below 10 GHz), 1 m*2) (above 10 GHz)		3 m (below 10 GHz), 1 m*2) (above 10 GHz)

*1) Although DA 00-705 accepts VBW = 10 Hz for AV measurements, it was confirmed that superfluous smoothing was not performed.

*2) Distance Factor: $20 \times \log(3.0 \text{ m} / 1.0 \text{ m}) = 9.5 \text{ dB}$

This EUT has two modes which Handheld Code Reader is put in Communication Unit or not. The worst case was confirmed with and without Handheld Code Reader, as a result, the test with Handheld Code Reader was the worst case. Therefore the test with Handheld Code Reader was performed only.

The test results and limit are rounded off to one decimal place, so some differences might be observed.

Measurement range : 30 M - 26.5 GHz
Test data : APPENDIX
Test result : Pass

UL Japan, Inc.

Ise EMC Lab.

4383-326 Asama-cho, Ise-shi, Mie-ken 516-0021 JAPAN

Telephone : +81 596 24 8999

Facsimile : +81 596 24 8124

SECTION 7: Antenna Terminal Conducted Tests

Test Procedure

The tests were made with below setting connected to the antenna port.

Test	Span	RBW	VBW	Sweep time	Detector	Trace	Instrument used
20dB Bandwidth	3 MHz	30 kHz	100 kHz	Auto	Peak	Max Hold	Spectrum Analyzer
99% Occupied Bandwidth *1)	Enough width to display emission skirts	1 to 5 % of OBW	Three times of RBW	Auto	Peak	Max Hold	Spectrum Analyzer
Maximum Peak Output Power	-	-	-	Auto	Peak Average *3)	-	Power Meter (Sensor: 50MHz BW)
Carrier Frequency Separation	3 MHz	100 kHz	300 kHz	Auto	Peak	Max Hold	Spectrum Analyzer
Number of Hopping Frequency	30 MHz	300 kHz	1 MHz	Auto	Peak	Max Hold	Spectrum Analyzer
Dwell Time	Zero Span	100 kHz, 1 MHz	300 kHz, 3 MHz	As necessary capture the entire dwell time per hopping channel	Peak	Clear Write	Spectrum Analyzer
Conducted Spurious Emission *2)	9 kHz to 150 kHz	200 Hz	620 Hz	Auto	Peak	Max Hold	Spectrum Analyzer
	150 kHz to 30 MHz	9.1 kHz	27 kHz				
	30 MHz to 25 GHz	100 kHz	300 kHz				
Conducted Spurious Emission Band Edge compliance	10 MHz	100 kHz	300 kHz	Auto	Peak	Max Hold	Spectrum Analyzer

*1) Peak hold was applied as Worst-case measurement.
 *2) In the frequency range below 30MHz, RBW was narrowed to separate the noise contents.
 Then, wide-band noise near the limit was checked separately, however the noise was not detected as shown in the chart.
 (9 kHz -150 kHz: RBW = 200 Hz, 150 kHz - 30 MHz: RBW = 9.1 kHz)
 *3) Reference data

The test results and limit are rounded off to two decimals place, so some differences might be observed.

Test data : APPENDIX
Test result : Pass

APPENDIX 1: Test data

Conducted Emission

DATA OF CONDUCTED EMISSION TEST

UL Japan, Inc. Ise EMC Lab. No. 4 Semi Anechoic Chamber
 Date : 2015/11/13

Report No. : 11047825H
 Temp./Humi. : 22deg. C / 56% RH
 Engineer : Koji Yamamoto

Mode / Remarks : DH5 2402MHz

LIMIT : FCC15.107(a) QP ClassB
 FCC15.107(a) AV ClassB

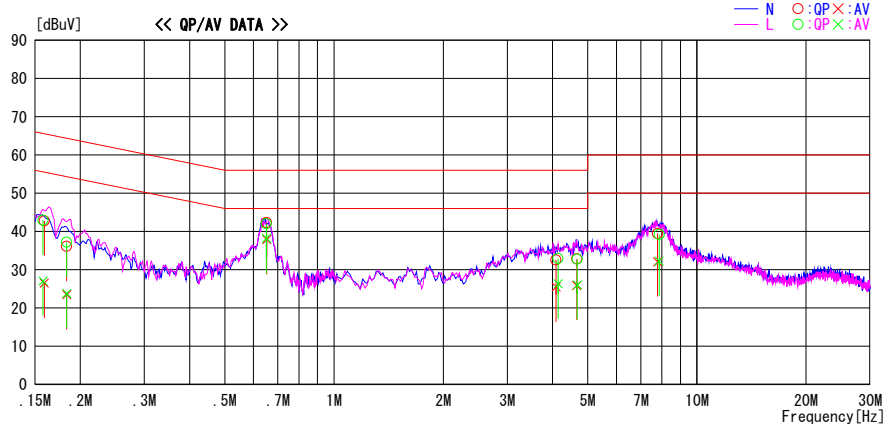

Frequency [MHz]	Reading Level		Corr. Factor	Results		Limit		Margin		Phase	Comment
	QP [dBuV]	AV [dBuV]		QP [dBuV]	AV [dBuV]	QP [dBuV]	AV [dBuV]	QP [dB]	AV [dB]		
0.15913	29.3	13.1	13.4	42.7	26.5	65.5	55.5	22.8	29.0	N	
0.18335	22.7	10.1	13.4	36.1	23.5	64.3	54.3	28.2	30.8	N	
0.65201	28.9	24.5	13.4	42.3	37.9	56.0	46.0	13.7	8.1	N	
4.09075	18.9	11.8	13.7	32.6	25.5	56.0	46.0	23.4	20.5	N	
4.66337	19.1	12.2	13.7	32.8	25.9	56.0	46.0	23.2	20.1	N	
7.79636	25.5	18.1	14.0	39.5	32.1	60.0	50.0	20.5	17.9	N	
0.15782	29.5	13.7	13.4	42.9	27.1	65.6	55.6	22.7	28.5	L	
0.18331	23.8	10.4	13.4	37.2	23.8	64.3	54.3	27.1	30.5	L	
0.65105	28.6	24.8	13.4	42.0	38.2	56.0	46.0	14.0	7.8	L	
4.14469	19.2	12.6	13.7	32.9	26.3	56.0	46.0	23.1	19.7	L	
4.67946	19.0	12.4	13.7	32.7	26.1	56.0	46.0	23.3	19.9	L	
7.86824	25.2	18.2	14.0	39.2	32.2	60.0	50.0	20.8	17.8	L	

CHART : WITH FACTOR. Peak hold data. CALCULATION : RESULT = READING + C.F (LISN + ATTN + CABLE)
 Except for the above table : adequate margin data below the limits.

Conducted Emission

Test place	Ise EMC Lab. No.4 Semi Anechoic Chamber
Report No.	11047825H
Date	November 12, 2015
Temperature / Humidity	22 deg. C / 56 % RH
Engineer	Koji Yamamoto
Mode	Tx, Hopping Off, DH5

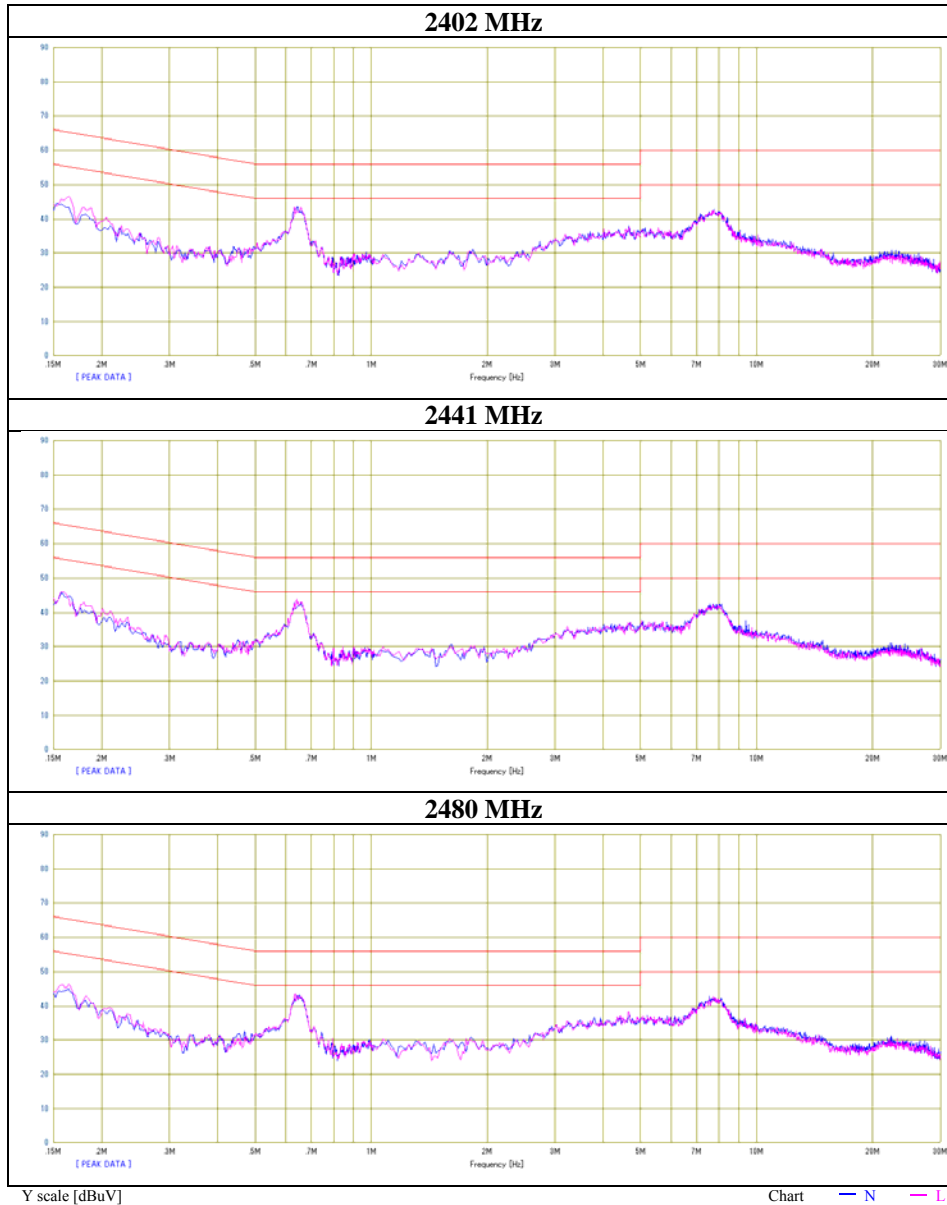

UL Japan, Inc.

Ise EMC Lab.

4383-326 Asama-cho, Ise-shi, Mie-ken 516-0021 JAPAN

Telephone : +81 596 24 8999

Facsimile : +81 596 24 8124

20dB Bandwidth and Carrier Frequency Separation

Test place Ise EMC Lab. No.11 Measurement Room
Report No. 11047825H
Date November 13, 2015
Temperature / Humidity 24 deg. C / 58 % RH
Engineer Takumi Shimada
Mode Tx, Hopping Off, DH5

Mode	Freq. [MHz]	20dB Bandwidth [MHz]	Carrier Frequency Separation [MHz]	Limit for Carrier Frequency separation [MHz]
DH5	2402.0	0.941	1.000	≥ 0.627
DH5	2441.0	0.862	1.000	≥ 0.575
DH5	2480.0	0.963	1.000	≥ 0.642

Limit: Two-thirds of 20dB Bandwidth or 25kHz (whichever is greater).

No limit applies to 20dB Bandwidth.

20dB Bandwidth and Carrier Frequency Separation

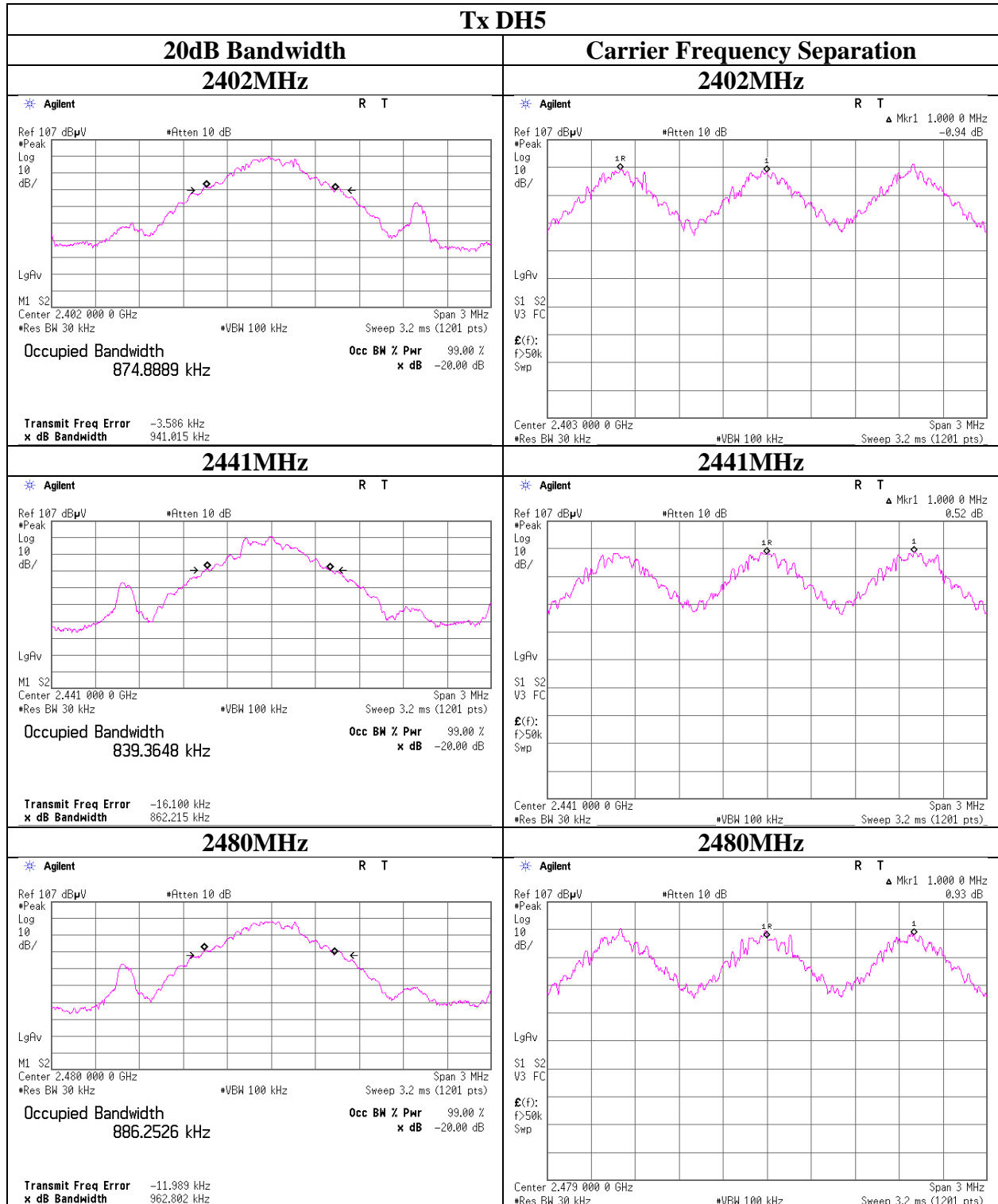

UL Japan, Inc.

Ise EMC Lab.

4383-326 Asama-cho, Ise-shi, Mie-ken 516-0021 JAPAN

Telephone : +81 596 24 8999

Facsimile : +81 596 24 8124

Number of Hopping Frequency

Test place Ise EMC Lab. No.11 Measurement Room
Report No. 11047825H
Date November 13, 2015
Temperature / Humidity 24 deg. C / 58 % RH
Engineer Takumi Shimada
Mode Tx, Hopping On

Mode	Number of channel [channels]	Limit [channels]
DH5	79	>= 15

Test was not performed at AFH mode whose number of hopping channel is 20 channels because this Bluetooth radio is in compliance of Bluetooth Specification.

Number of Hopping Frequency

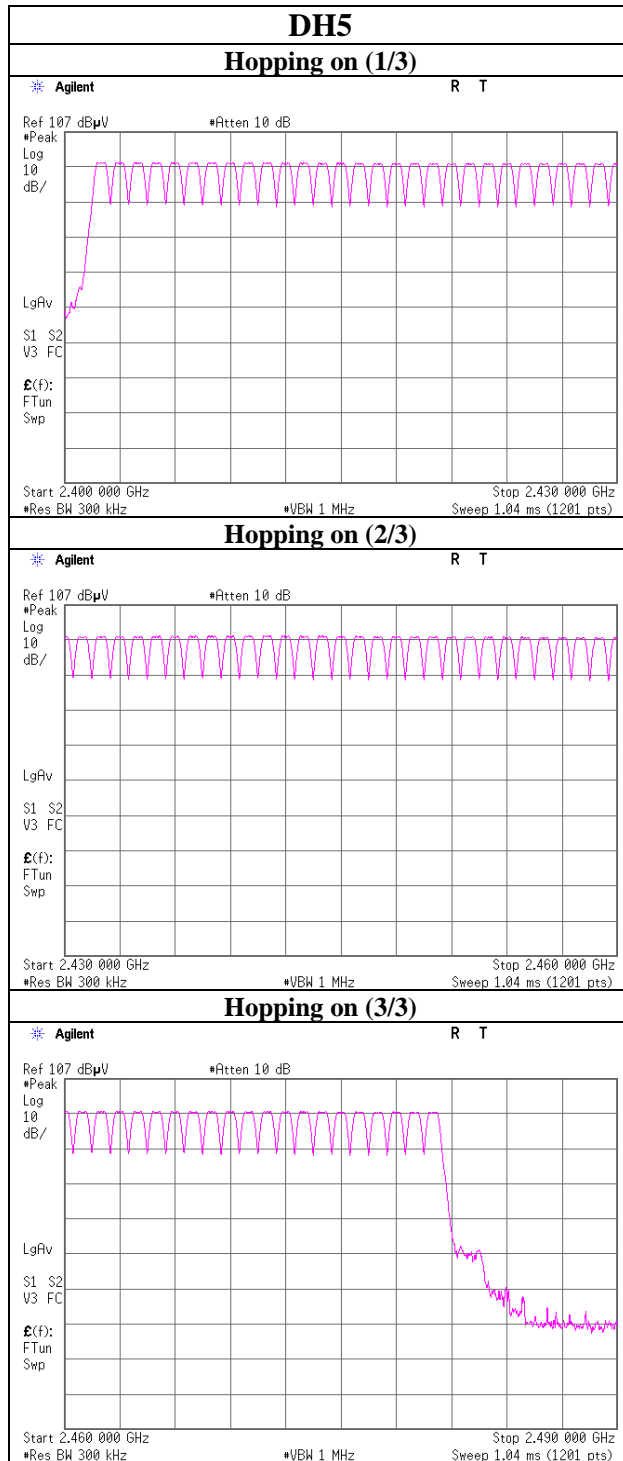

Dwell time

Test place Ise EMC Lab. No.11 Measurement Room
Report No. 11047825H
Date November 13, 2015
Temperature / Humidity 24 deg. C / 58 % RH
Engineer Takumi Shimada
Mode Tx, Hopping On

Mode	Number of transmission in a 31.6(79 Hopping x 0.4) / 12.8 (32 Hopping x 0.4) second period	Length of transmission [msec]	Result [msec]	Limit [msec]
DH1	50.0 times / 5 sec. x 31.6 sec. = 316 times	0.513	162	400
DH3	26.0 times / 5 sec. x 31.6 sec. = 165 times	1.776	293	400
DH5	17.0 times / 5 sec. x 31.6 sec. = 108 times	3.070	332	400

Sample Calculation

Result = Number of transmission x Length of transmission

This device complies with the Bluetooth protocol for FHSS operation, employing a pseudo random channel selection and hopping rate to ensure that the occupancy time in $N \times 0.4s$, where N is the number of channels being used in the hopping sequence ($20 \leq N \leq 79$), is always less than $0.4s$ regardless of packet size. This is confirmed in the test report for $N = 79$.

Dwell time

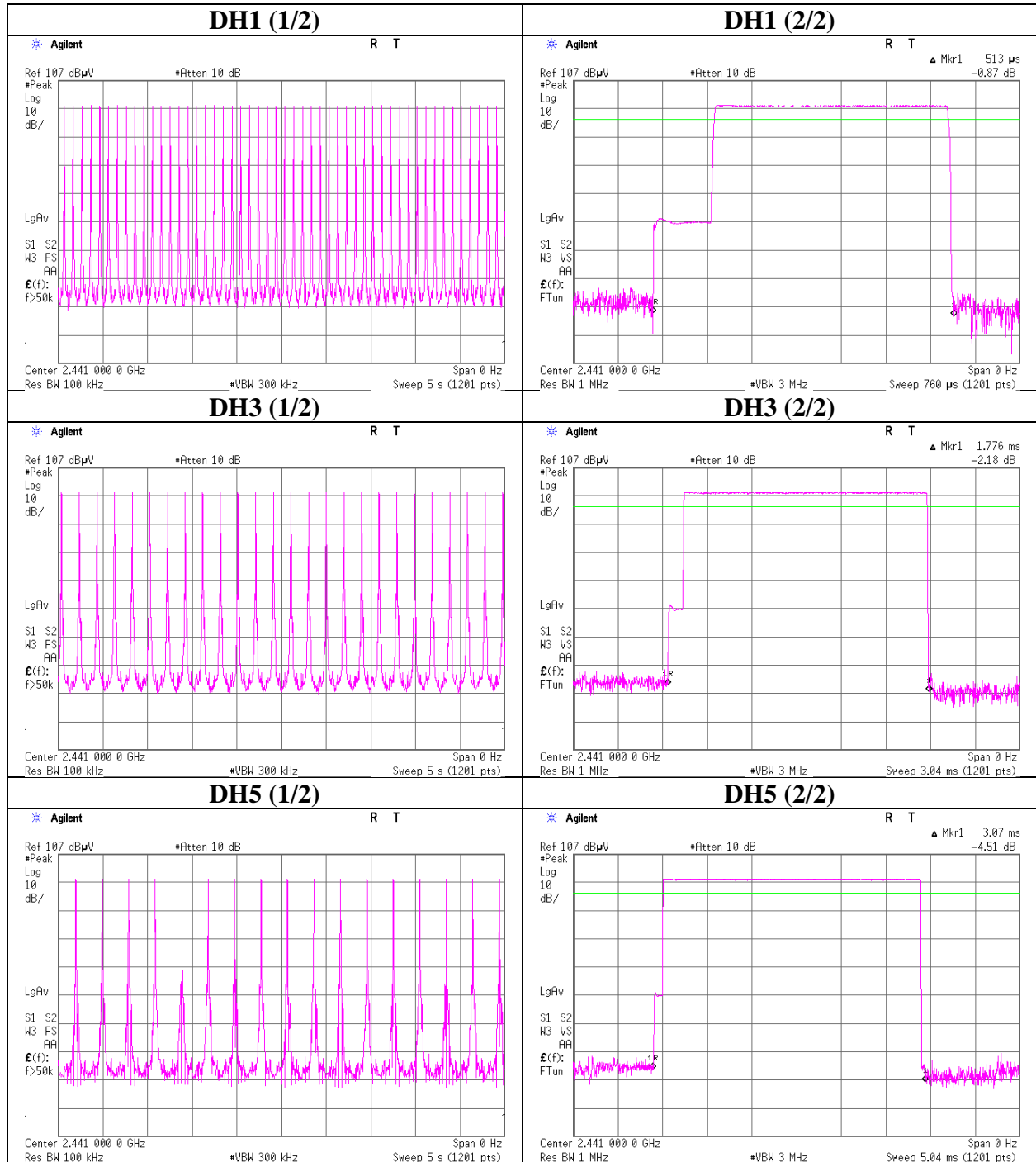

UL Japan, Inc.

Ise EMC Lab.

4383-326 Asama-cho, Ise-shi, Mie-ken 516-0021 JAPAN

Telephone : +81 596 24 8999

Facsimile : +81 596 24 8124

Maximum Peak Output Power

Test place Ise EMC Lab. No.11 Measurement Room
Report No. 11047825H
Date November 13, 2015
Temperature / Humidity 24 deg. C / 58 % RH
Engineer Takumi Shimada
Mode Tx, Hopping Off

Mode	Freq. [MHz]	Reading [dBm]	Cable Loss [dB]	Atten. Loss [dB]	Result		Limit		Margin [dB]
					[dBm]	[mW]	[dBm]	[mW]	
DH5	2402.0	-8.35	1.37	0.00	-6.98	0.20	20.96	125	27.94
DH5	2441.0	-8.67	1.37	0.00	-7.30	0.19	20.96	125	28.26
DH5	2480.0	-9.02	1.38	0.00	-7.64	0.17	20.96	125	28.60

Sample Calculation:

Result = Reading + Cable Loss + Attenuator Loss

*The equipment and cables were not used for factor 0 dB of the data sheets.

Test was not performed at AFH mode, because the decrease of number of channel (min: 20ch) at AFH mode does not influence on the output power and bandwidth of the EUT.

However, the limit level 125mW of AFH mode was used for the test.

Average Output Power
(Reference data)

Test place : Ise EMC Lab. No.11 Measurement Room
Report No. : 11047825H
Date : November 13, 2015
Temperature / Humidity : 24 deg. C / 58 % RH
Engineer : Takumi Shimada
Mode : Tx, Hopping Off

Mode	Freq. [MHz]	Reading [dBm]	Cable Loss [dB]	Atten. Loss [dB]	Result (Frame power)	
					[dBm]	[mW]
DH5	2402.0	-10.16	1.37	0.00	-8.79	0.13
DH5	2441.0	-10.28	1.37	0.00	-8.91	0.13
DH5	2480.0	-10.57	1.38	0.00	-9.19	0.12

Sample Calculation:

Result (Frame power) = Reading + Cable Loss + Attenuator Loss

*The equipment and cables were not used for factor 0 dB of the data sheets.

Radiated Spurious Emission

Test place : Ise EMC Lab. No.4 Semi Anechoic Chamber
Report No. : 11047825H
Date : November 12, 2015 November 12, 2015
Temperature / Humidity : 23 deg. C / 55 % RH 22 deg. C / 51 % RH
Engineer : Yuta Moriya Koji Yamamoto
 (1-10GHz) (Above 10GHz and Below 1GHz)
Mode : Tx, Hopping Off, DH5 2402 MHz

Polarity	Frequency [MHz]	Detector	Reading [dBuV]	Ant.Fac. [dB/m]	Loss [dB]	Gain [dB]	Result [dBuV/m]	Limit [dBuV/m]	Margin [dB]	Remark
Hori	157.494	QP	35.1	15.4	8.7	31.9	27.3	43.5	16.2	
Hori	166.415	QP	38.8	15.7	8.8	31.9	31.4	43.5	12.1	
Hori	214.768	QP	37.4	16.7	9.2	31.8	31.5	43.5	12.0	
Hori	329.314	QP	39.3	17.5	10.1	31.8	35.1	46.0	10.9	
Hori	357.951	QP	36.0	17.8	10.3	31.8	32.3	46.0	13.7	
Hori	532.002	QP	43.5	19.6	11.4	32.0	42.5	46.0	3.5	
Hori	2390.000	PK	44.1	27.9	3.3	32.1	43.2	73.9	30.7	
Hori	4804.000	PK	44.7	32.8	5.6	31.3	51.8	73.9	22.1	
Hori	7206.000	PK	42.7	36.8	6.6	32.6	53.5	73.9	20.4	Floor Noise
Hori	9608.000	PK	42.3	38.1	7.6	32.6	55.4	73.9	18.5	Floor Noise
Hori	2390.000	AV	28.3	27.9	3.3	32.1	27.4	53.9	26.5	
Hori	4804.000	AV	36.7	32.8	5.6	31.3	43.8	53.9	10.1	
Hori	7206.000	AV	30.0	36.8	6.6	32.6	40.8	53.9	13.1	Floor Noise
Hori	9608.000	AV	29.9	38.1	7.6	32.6	43.0	53.9	10.9	Floor Noise
Vert	157.497	QP	31.7	15.4	8.7	31.9	23.9	43.5	19.6	
Vert	166.416	QP	42.5	15.7	8.8	31.9	35.1	43.5	8.4	
Vert	214.771	QP	37.0	16.7	9.2	31.8	31.1	43.5	12.4	
Vert	501.132	QP	37.5	19.4	11.2	32.0	36.1	46.0	9.9	
Vert	532.004	QP	40.3	19.6	11.4	32.0	39.3	46.0	6.7	
Vert	558.406	QP	35.1	19.8	11.5	32.0	34.4	46.0	11.6	
Vert	2390.000	PK	44.4	27.9	3.3	32.1	43.5	73.9	30.4	
Vert	4804.000	PK	47.6	32.8	5.6	31.3	54.7	73.9	19.2	
Vert	7206.000	PK	42.6	36.8	6.6	32.6	53.4	73.9	20.6	Floor Noise
Vert	9608.000	PK	42.2	38.1	7.6	32.6	55.3	73.9	18.6	Floor Noise
Vert	2390.000	AV	28.2	27.9	3.3	32.1	27.3	53.9	26.6	
Vert	4804.000	AV	41.6	32.8	5.6	31.3	48.7	53.9	5.2	
Vert	7206.000	AV	30.2	36.8	6.6	32.6	41.0	53.9	12.9	Floor Noise
Vert	9608.000	AV	29.9	38.1	7.6	32.6	43.0	53.9	10.9	Floor Noise

Result = Reading + Ant Factor + Loss (Cable+Attenuator+Filter-Distance factor(above 10 GHz)) - Gain(Amplifier)

*Other frequency noises omitted in this report were not seen or had enough margin (more than 20 dB).

Distance factor: 10 GHz - 26.5 GHz 20log(3.0 m / 1.0 m) = 9.5dB

20dBc Data Sheet

Polarity	Frequency [MHz]	Detector	Reading [dBuV]	Ant Factor [dB/m]	Loss [dB]	Gain [dB]	Result [dBuV/m]	Limit [dBuV/m]	Margin [dB]	Remark
Hori	2402.000	PK	86.6	28.0	3.3	32.1	85.8	-	-	Carrier
Hori	2400.000	PK	45.9	28.0	3.3	32.1	45.1	65.8	20.7	
Vert	2402.000	PK	79.7	28.0	3.3	32.1	78.9	-	-	Carrier
Vert	2400.000	PK	40.1	28.0	3.3	32.1	39.3	58.9	19.6	

Result = Reading + Ant Factor + Loss (Cable+Attenuator+Filter-Distance factor(above 10GHz)) - Gain(Amplifier)

Radiated Spurious Emission (Plot data, Worst case)

Test place	Ise EMC Lab. No.4 Semi Anechoic Chamber	
Report No.	11047825H	
Date	November 12, 2015	November 12, 2015
Temperature / Humidity	23 deg. C / 55 % RH	22 deg. C / 51 % RH
Engineer	Yuta Moriya	Koji Yamamoto
	(1-10GHz)	(Above 10GHz and Below 1 GHz)
Mode	Tx, Hopping Off, DH5 2402MHz	

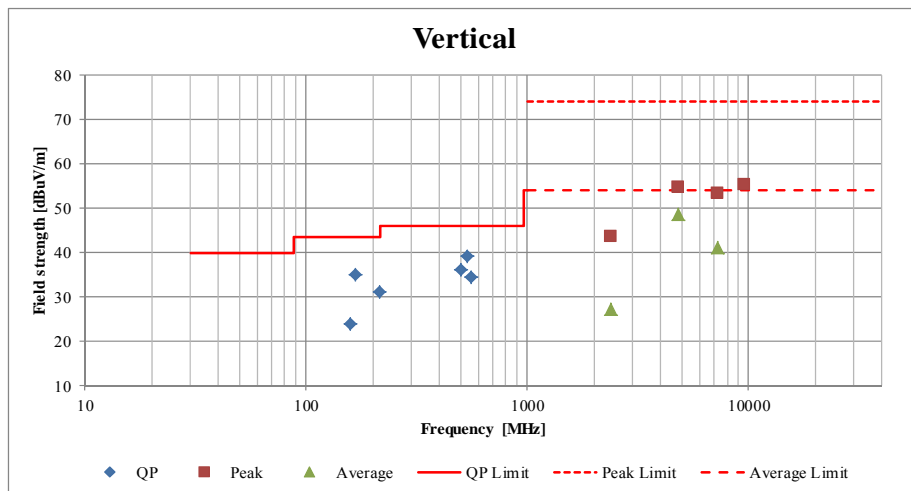
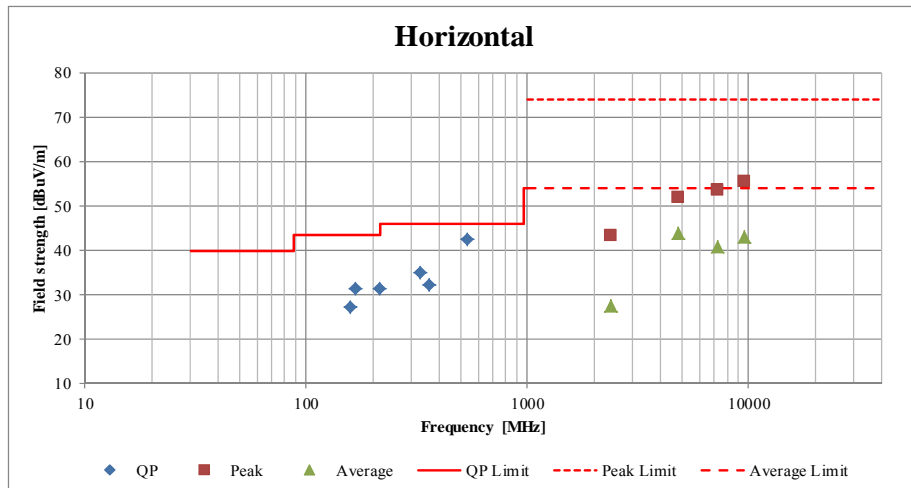

*These plots data contains sufficient number to show the trend of characteristic features for EUT.

Radiated Spurious Emission (Reference Plot for band-edge)

Test place	Ise EMC Lab. No.4 Semi Anechoic Chamber
Report No.	11047825H
Date	November 12, 2015
Temperature / Humidity	23 deg. C / 55 % RH
Engineer	Yuta Moriya
	(1-10GHz)
Mode	Tx, Hopping Off, DH5 2402 MHz

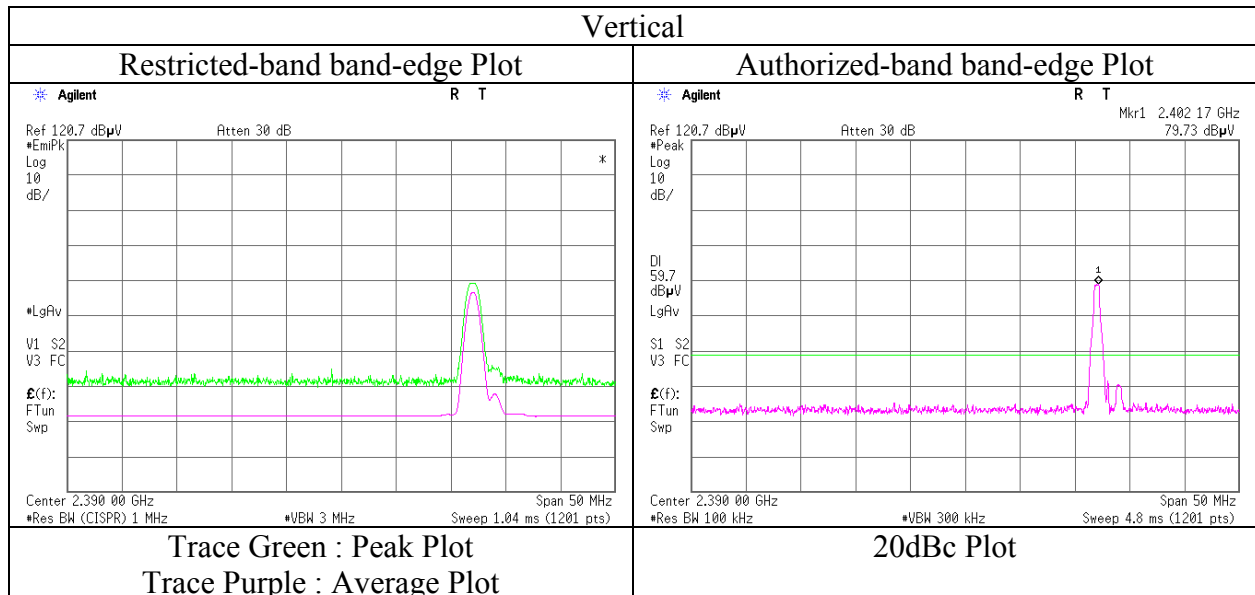
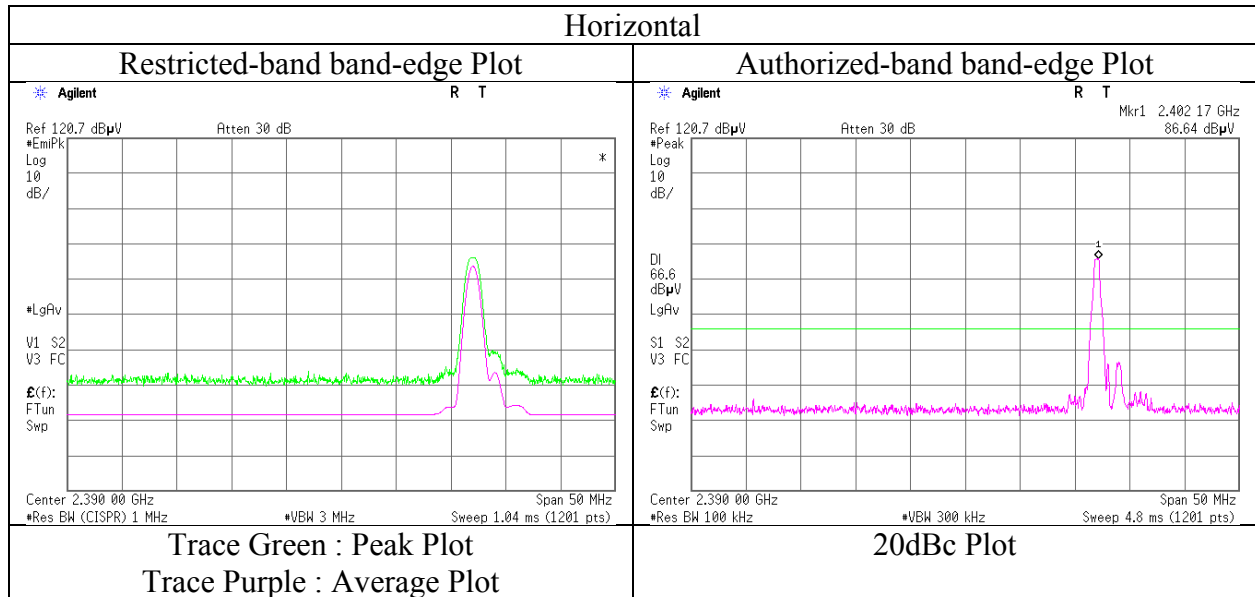

* Final result of restricted band edge was shown in tabular data.

Radiated Spurious Emission

Test place : Ise EMC Lab. No.4 Semi Anechoic Chamber
Report No. : 11047825H
Date : November 12, 2015 November 12, 2015
Temperature / Humidity : 23 deg. C / 55 % RH 22 deg. C / 51 % RH
Engineer : Yuta Moriya Koji Yamamoto
 (1-10GHz) (Above 10GHz and Below 1GHz)
Mode : Tx, Hopping Off, DH5 2441 MHz

Polarity	Frequency [MHz]	Detector	Reading [dBuV]	Ant.Fac. [dB/m]	Loss [dB]	Gain [dB]	Result [dBuV/m]	Limit [dBuV/m]	Margin [dB]	Remark
Hori	157.495	QP	35.6	15.4	8.7	31.9	27.8	43.5	15.7	
Hori	166.415	QP	38.2	15.7	8.8	31.9	30.8	43.5	12.7	
Hori	214.768	QP	37.1	16.7	9.2	31.8	31.2	43.5	12.3	
Hori	329.309	QP	39.5	17.5	10.1	31.8	35.3	46.0	10.7	
Hori	357.950	QP	35.5	17.8	10.3	31.8	31.8	46.0	14.2	
Hori	532.003	QP	40.9	19.6	11.4	32.0	39.9	46.0	6.1	
Hori	4882.000	PK	46.2	33.1	5.6	31.3	53.6	73.9	20.3	
Hori	7323.000	PK	42.3	36.8	6.7	32.6	53.2	73.9	20.7	Floor Noise
Hori	9764.000	PK	42.2	38.2	7.6	32.7	55.3	73.9	18.6	Floor Noise
Hori	4882.000	AV	37.8	33.1	5.6	31.3	45.2	53.9	8.7	
Hori	7323.000	AV	30.1	36.8	6.7	32.6	41.0	53.9	12.9	Floor Noise
Hori	9764.000	AV	29.9	38.2	7.6	32.7	43.0	53.9	10.9	Floor Noise
Vert	157.493	QP	32.0	15.4	8.7	31.9	24.2	43.5	19.3	
Vert	166.415	QP	41.8	15.7	8.8	31.9	34.4	43.5	9.1	
Vert	214.772	QP	37.3	16.7	9.2	31.8	31.4	43.5	12.1	
Vert	501.107	QP	37.2	19.4	11.2	32.0	35.8	46.0	10.2	
Vert	532.001	QP	39.8	19.6	11.4	32.0	38.8	46.0	7.2	
Vert	558.406	QP	35.7	19.8	11.5	32.0	35.0	46.0	11.0	
Vert	4882.000	PK	48.0	33.1	5.6	31.3	55.4	73.9	18.5	
Vert	7323.000	PK	42.2	36.8	6.7	32.6	53.1	73.9	20.8	Floor Noise
Vert	9764.000	PK	42.1	38.2	7.6	32.7	55.2	73.9	18.7	Floor Noise
Vert	4882.000	AV	41.6	33.1	5.6	31.3	49.0	53.9	4.9	
Vert	7323.000	AV	30.1	36.8	6.7	32.6	41.0	53.9	12.9	Floor Noise
Vert	9764.000	AV	30.0	38.2	7.6	32.7	43.1	53.9	10.8	Floor Noise

Result = Reading + Ant Factor + Loss (Cable+Attenuator+Filter-Distance factor(above 10 GHz)) - Gain(Amplifier)

*Other frequency noises omitted in this report were not seen or had enough margin (more than 20 dB).

Distance factor: 10 GHz - 26.5 GHz 20log(3.0 m / 1.0 m) = 9.5dB

Radiated Spurious Emission

Test place Ise EMC Lab. No.4 Semi Anechoic Chamber
Report No. 11047825H
Date November 12, 2015 November 12, 2015
Temperature / Humidity 23 deg. C / 55 % RH 22 deg. C / 51 % RH
Engineer Yuta Moriya Koji Yamamoto
(1-10GHz) (Above 10GHz and Below 1GHz)
Mode Tx, Hopping Off, DH5 2480 MHz

Polarity	Frequency [MHz]	Detector	Reading [dBuV]	Ant.Fac. [dB/m]	Loss [dB]	Gain [dB]	Result [dBuV/m]	Limit [dBuV/m]	Margin [dB]	Remark
Hori	157.495	QP	36.6	15.4	8.7	31.9	28.8	43.5	14.7	
Hori	166.411	QP	37.5	15.7	8.8	31.9	30.1	43.5	13.4	
Hori	214.768	QP	38.3	16.7	9.2	31.8	32.4	43.5	11.1	
Hori	329.171	QP	40.1	17.5	10.1	31.8	35.9	46.0	10.1	
Hori	357.916	QP	35.2	17.8	10.3	31.8	31.5	46.0	14.5	
Hori	532.001	QP	40.7	19.6	11.4	32.0	39.7	46.0	6.3	
Hori	2483.500	PK	49.5	28.1	3.3	32.1	48.8	73.9	25.1	
Hori	4960.000	PK	44.1	33.4	5.6	31.2	51.9	73.9	22.0	
Hori	7440.000	PK	42.2	36.8	6.7	32.7	53.0	73.9	20.9	Floor Noise
Hori	9920.000	PK	42.2	38.3	7.7	32.8	55.4	73.9	18.5	Floor Noise
Hori	2483.500	AV	32.8	28.1	3.3	32.1	32.1	53.9	21.8	
Hori	4960.000	AV	36.5	33.4	5.6	31.2	44.3	53.9	9.6	
Hori	7440.000	AV	30.0	36.8	6.7	32.7	40.8	53.9	13.1	Floor Noise
Hori	9920.000	AV	30.0	38.3	7.7	32.8	43.2	53.9	10.7	Floor Noise
Vert	157.490	QP	33.7	15.4	8.7	31.9	25.9	43.5	17.6	
Vert	166.422	QP	40.9	15.7	8.8	31.9	33.5	43.5	10.0	
Vert	214.786	QP	36.8	16.7	9.2	31.8	30.9	43.5	12.6	
Vert	501.101	QP	37.8	19.4	11.2	32.0	36.4	46.0	9.6	
Vert	532.001	QP	38.6	19.6	11.4	32.0	37.6	46.0	8.4	
Vert	558.398	QP	36.1	19.8	11.5	32.0	35.4	46.0	10.6	
Vert	2483.500	PK	43.6	28.1	3.3	32.1	42.9	73.9	31.0	
Vert	4960.000	PK	46.6	33.4	5.6	31.2	54.4	73.9	19.5	
Vert	7440.000	PK	42.1	36.8	6.7	32.7	52.9	73.9	21.0	Floor Noise
Vert	9920.000	PK	42.2	38.3	7.7	32.8	55.4	73.9	18.5	Floor Noise
Vert	2483.500	AV	29.0	28.1	3.3	32.1	28.3	53.9	25.6	
Vert	4960.000	AV	39.8	33.4	5.6	31.2	47.6	53.9	6.3	
Vert	7440.000	AV	30.0	36.8	6.7	32.7	40.8	53.9	13.1	Floor Noise
Vert	9920.000	AV	29.9	38.3	7.7	32.8	43.1	53.9	10.8	Floor Noise

Result = Reading + Ant Factor + Loss (Cable+Attenuator+Filter-Distance factor(above 10 GHz)) - Gain(Amplifier)

*Other frequency noises omitted in this report were not seen or had enough margin (more than 20 dB).

Distance factor: 10 GHz - 26.5 GHz 20log(3.0 m / 1.0 m) = 9.5dB

Radiated Spurious Emission (Reference Plot for band-edge)

Test place	Ise EMC Lab. No.4 Semi Anechoic Chamber
Report No.	11047825H
Date	November 12, 2015
Temperature / Humidity	23 deg. C / 55 % RH
Engineer	Yuta Moriya (1-10GHz)
Mode	Tx, Hopping Off, DH5 2480 MHz

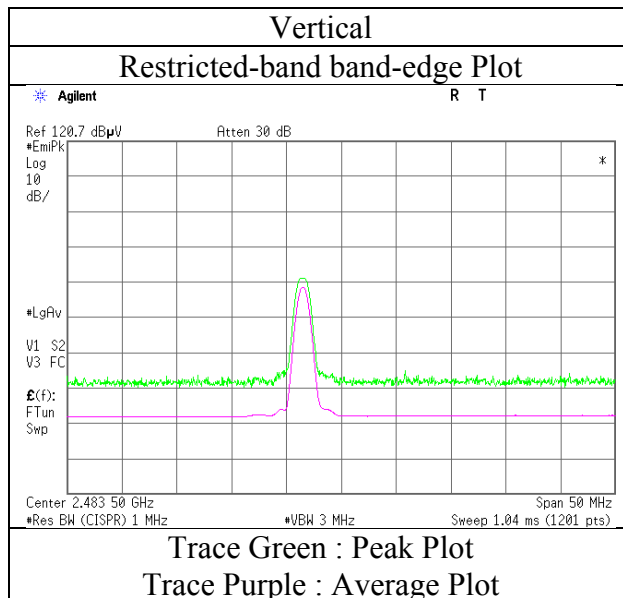
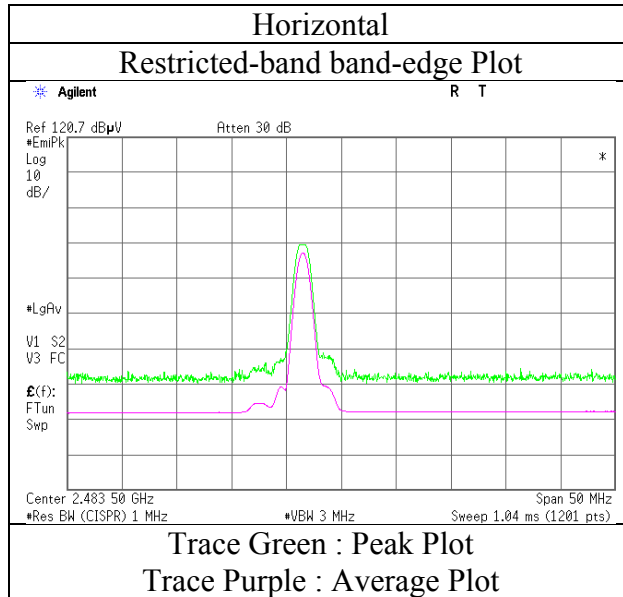

* Final result of restricted band edge was shown in tabular data.

Conducted Spurious Emission

Test place	Ise EMC Lab. No.11 Measurement Room
Report No.	11047825H
Date	November 13, 2015
Temperature / Humidity	24 deg. C / 58 % RH
Engineer	Takumi Shimada
Mode	Tx, Hopping Off, DH5

2402 MHz

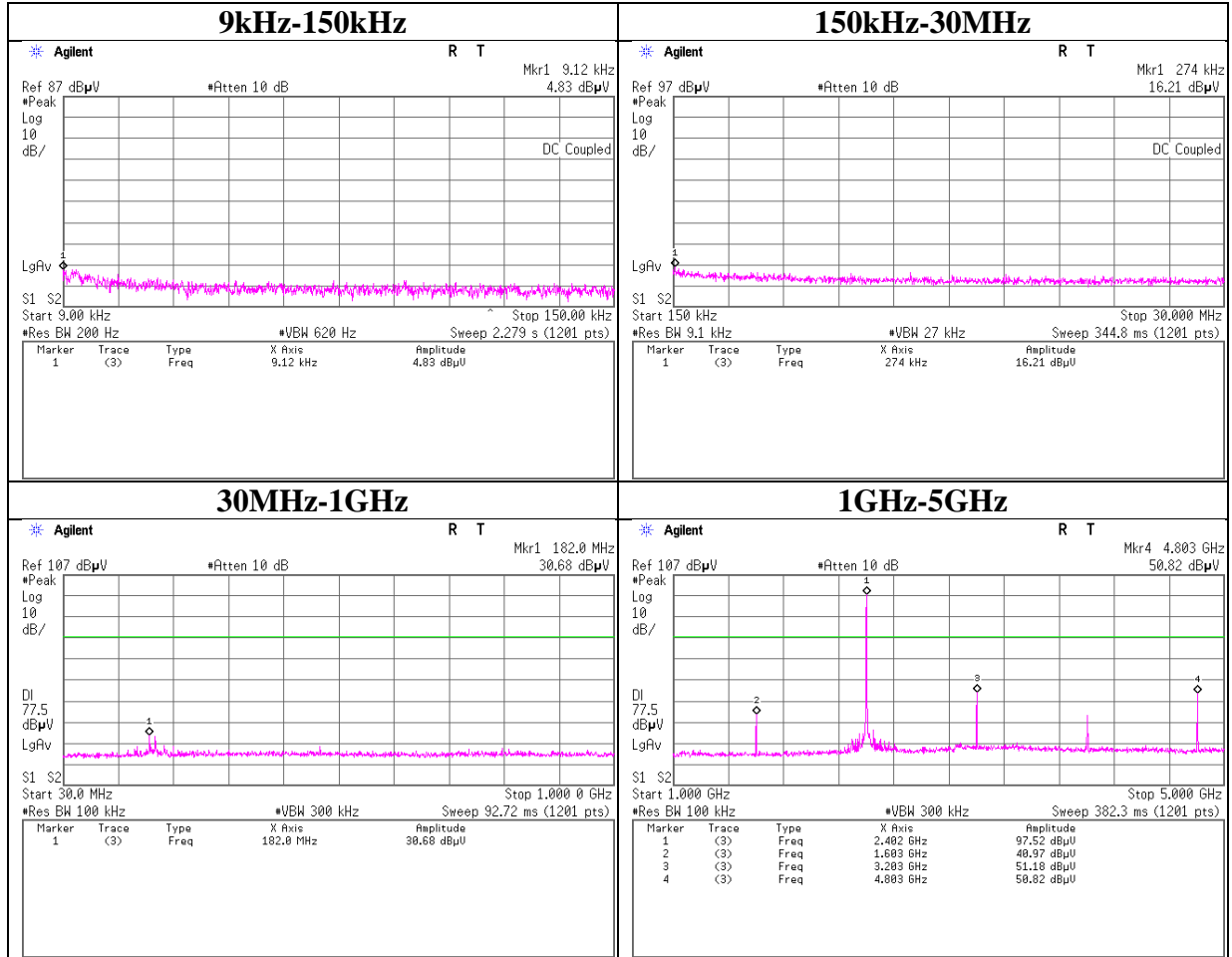

UL Japan, Inc.

Ise EMC Lab.

4383-326 Asama-cho, Ise-shi, Mie-ken 516-0021 JAPAN

Telephone : +81 596 24 8999

Facsimile : +81 596 24 8124

Conducted Spurious Emission

Test place	Ise EMC Lab. No.11 Measurement Room
Report No.	11047825H
Date	November 13, 2015
Temperature / Humidity	24 deg. C / 58 % RH
Engineer	Takumi Shimada
Mode	Tx, Hopping Off, DH5

2402 MHz

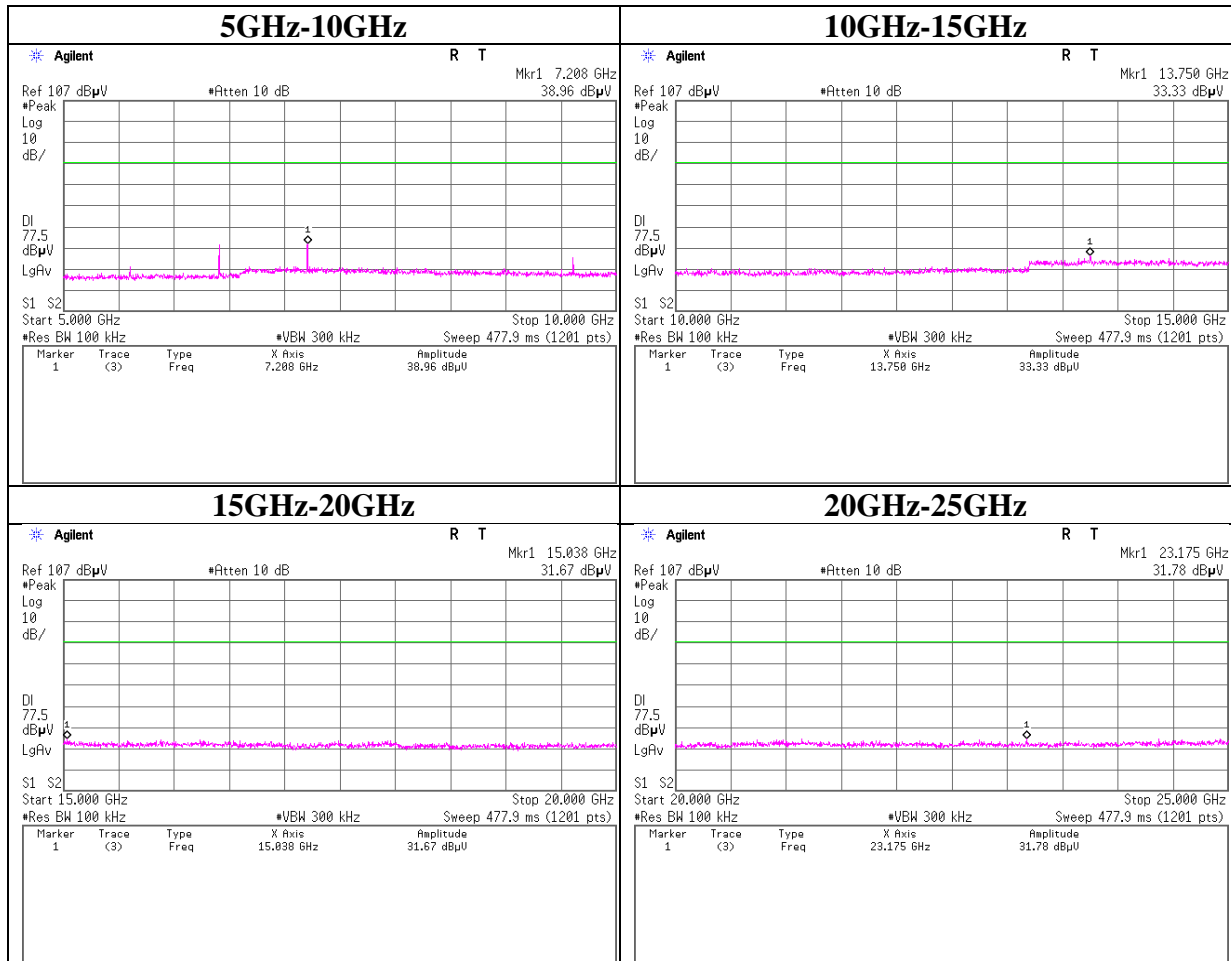

Conducted Spurious Emission

Test place	Ise EMC Lab. No.11 Measurement Room
Report No.	11047825H
Date	November 13, 2015
Temperature / Humidity	24 deg. C / 58 % RH
Engineer	Takumi Shimada
Mode	Tx, Hopping Off, DH5

2441 MHz

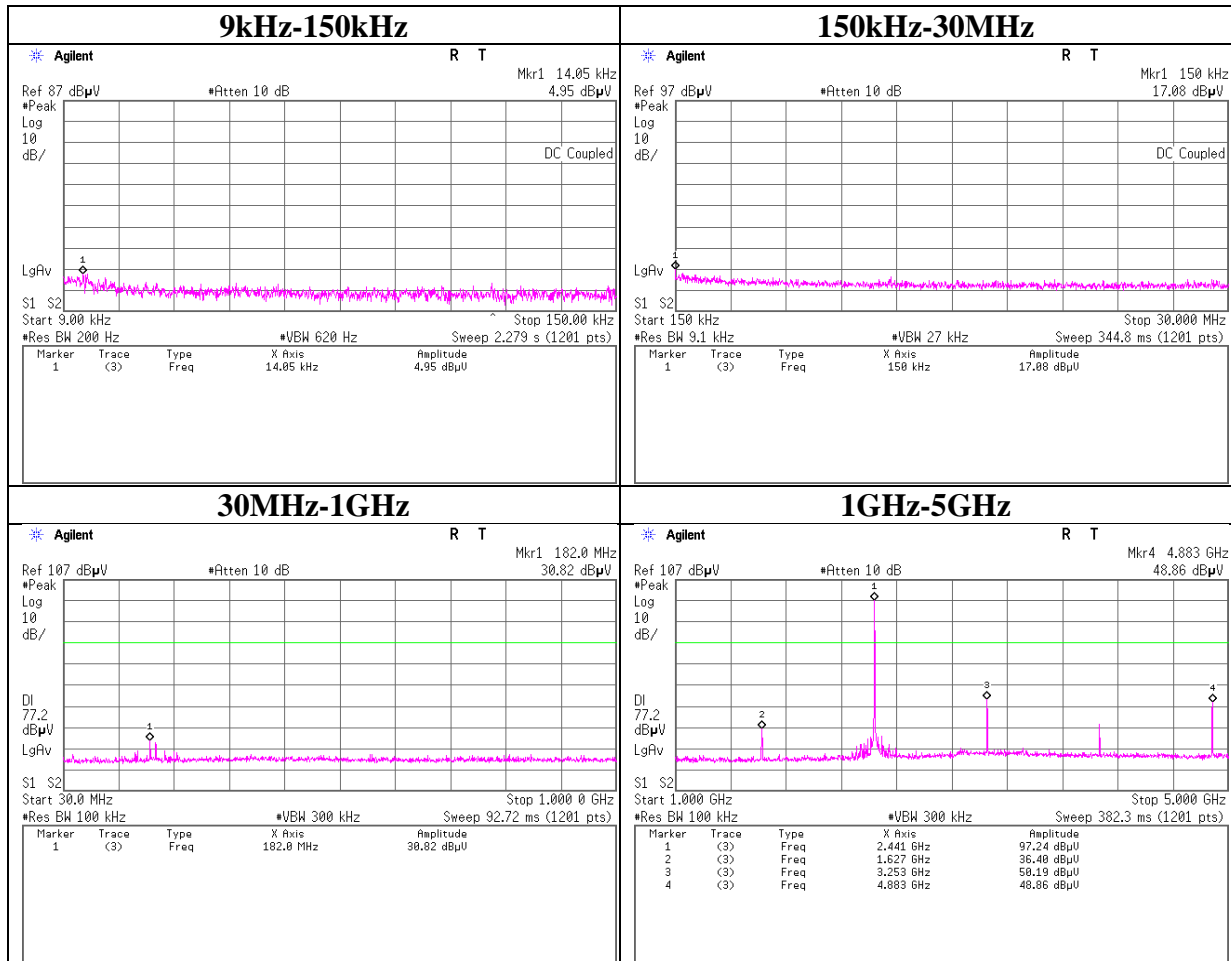

Conducted Spurious Emission

Test place	Ise EMC Lab. No.11 Measurement Room
Report No.	11047825H
Date	November 13, 2015
Temperature / Humidity	24 deg. C / 58 % RH
Engineer	Takumi Shimada
Mode	Tx, Hopping Off, DH5

2441 MHz

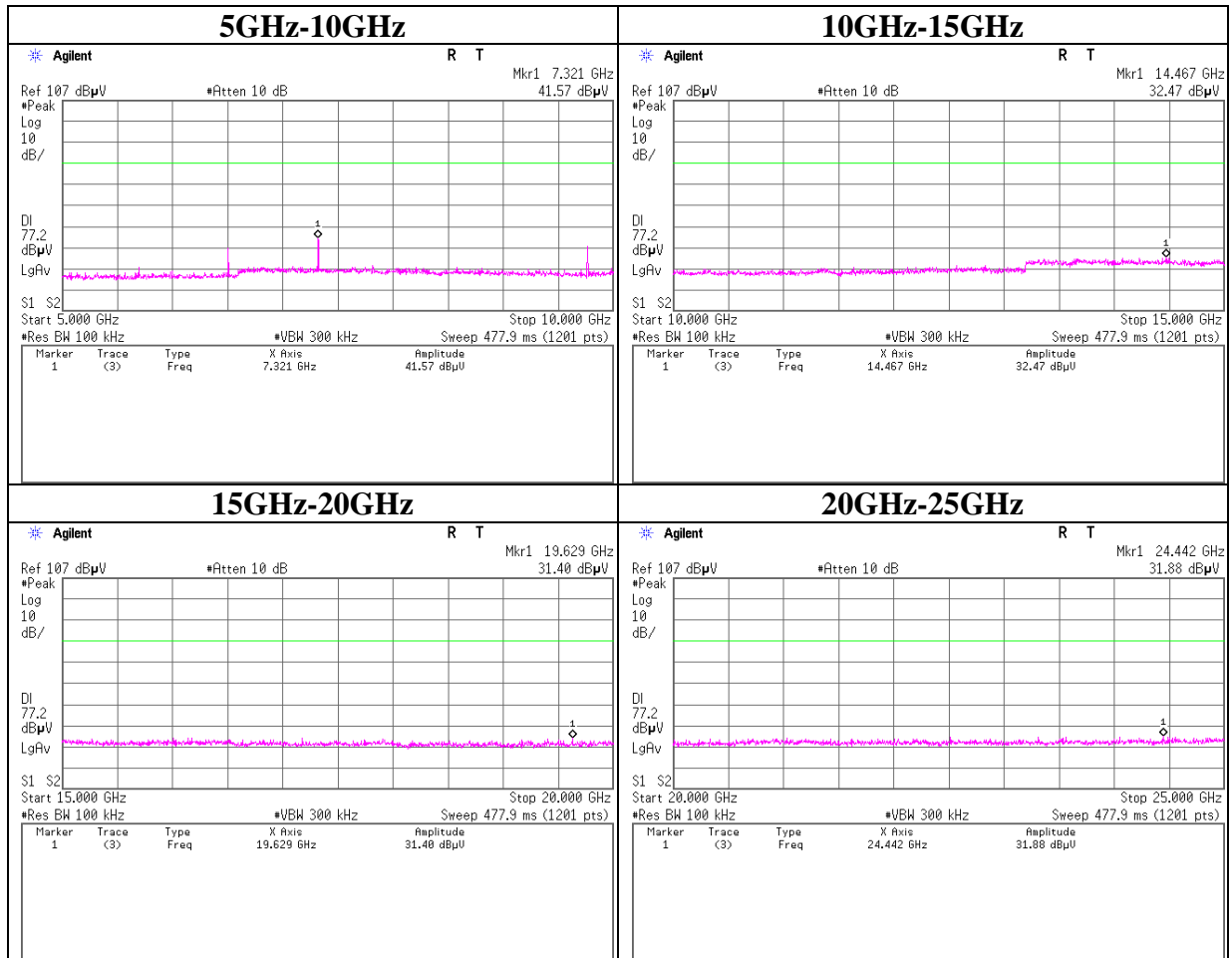

Conducted Spurious Emission

Test place	Ise EMC Lab. No.11 Measurement Room
Report No.	11047825H
Date	November 13, 2015
Temperature / Humidity	24 deg. C / 58 % RH
Engineer	Takumi Shimada
Mode	Tx, Hopping Off, DH5

2480 MHz

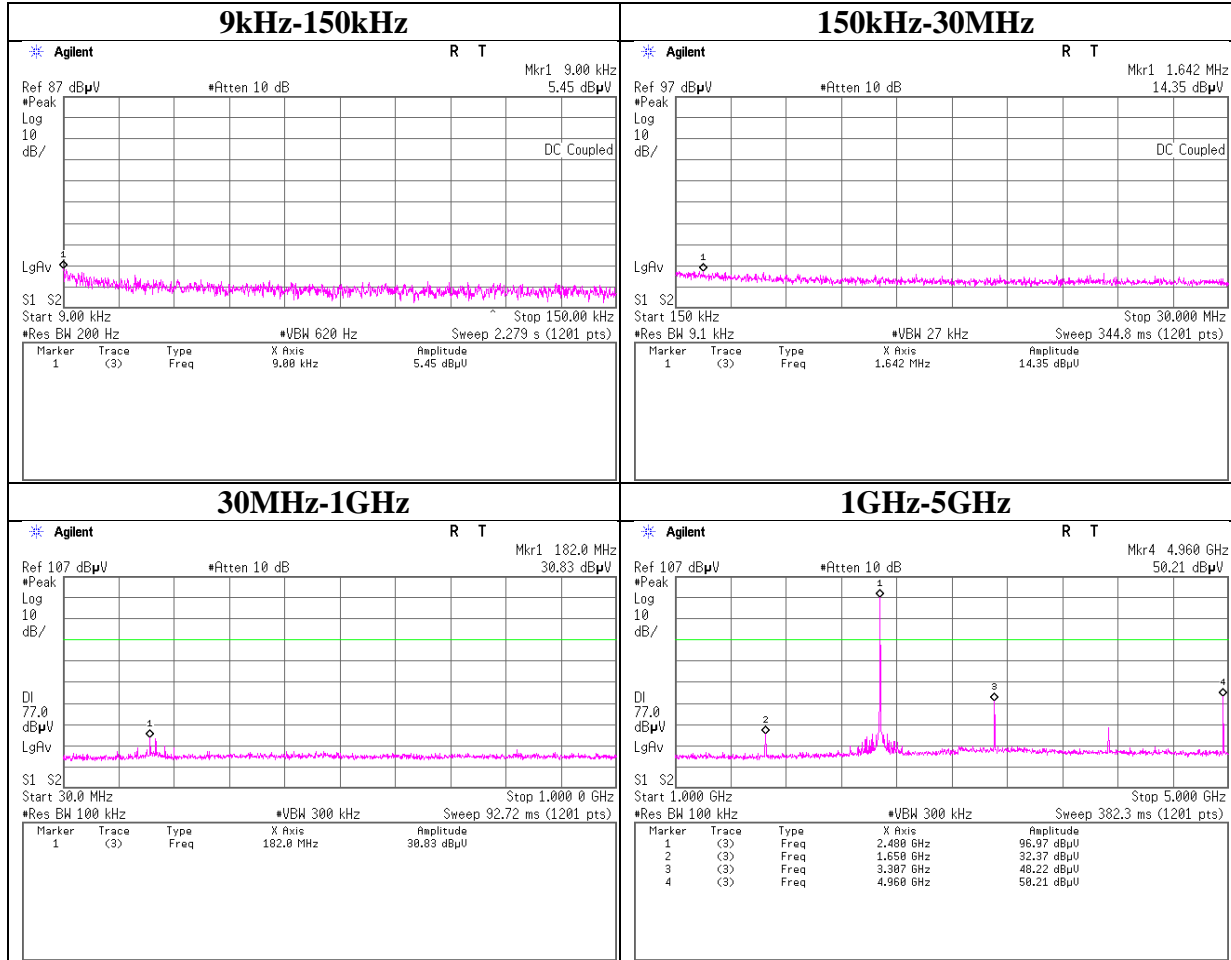

Conducted Spurious Emission

Test place	Ise EMC Lab. No.11 Measurement Room
Report No.	11047825H
Date	November 13, 2015
Temperature / Humidity	24 deg. C / 58 % RH
Engineer	Takumi Shimada
Mode	Tx, Hopping Off, DH5

2480 MHz

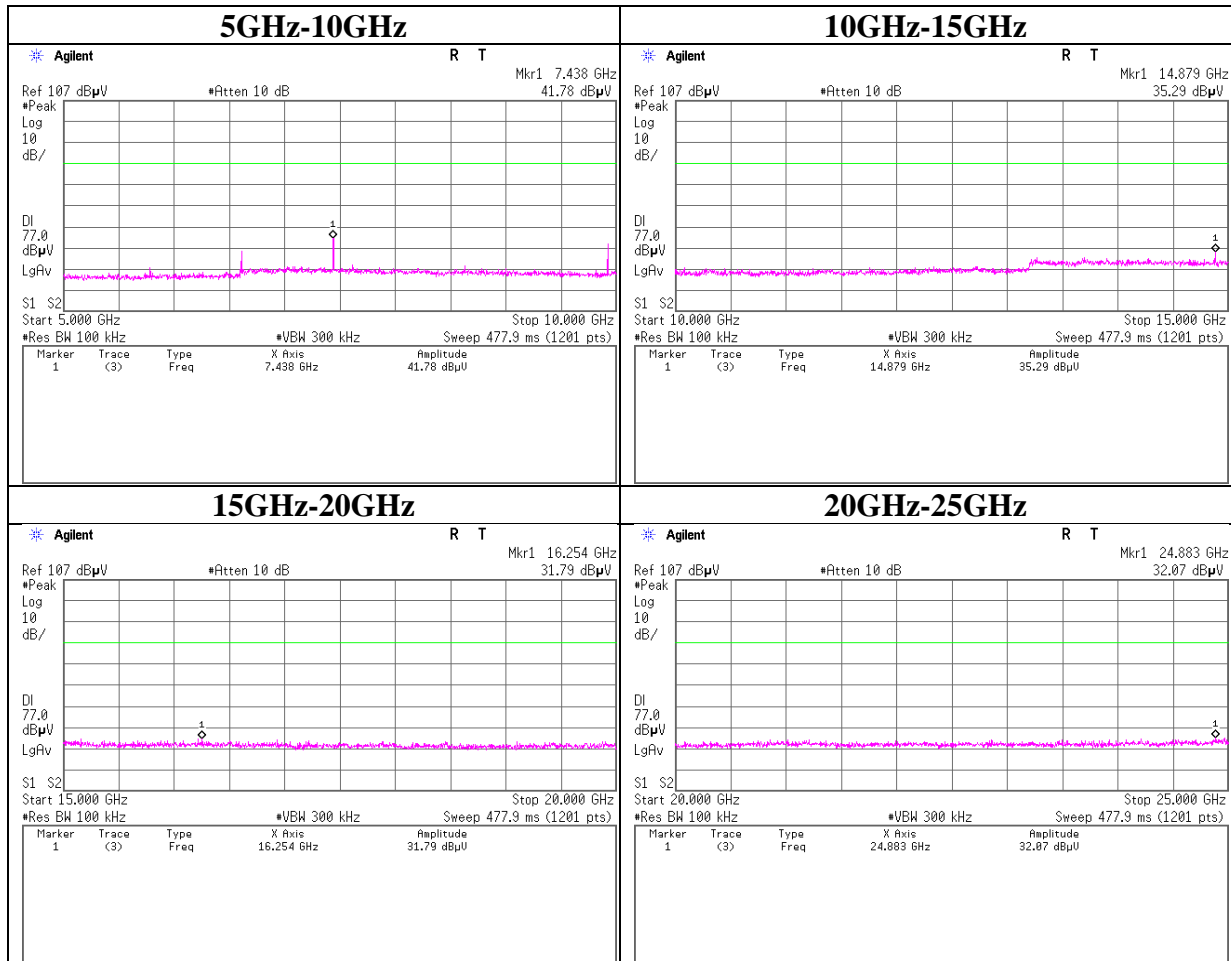

Conducted Emission Band Edge compliance

Test place	Ise EMC Lab. No.11 Measurement Room
Report No.	11047825H
Date	November 13, 2015
Temperature / Humidity	24 deg. C / 58 % RH
Engineer	Takumi Shimada
Mode	Tx DH5

Hopping On

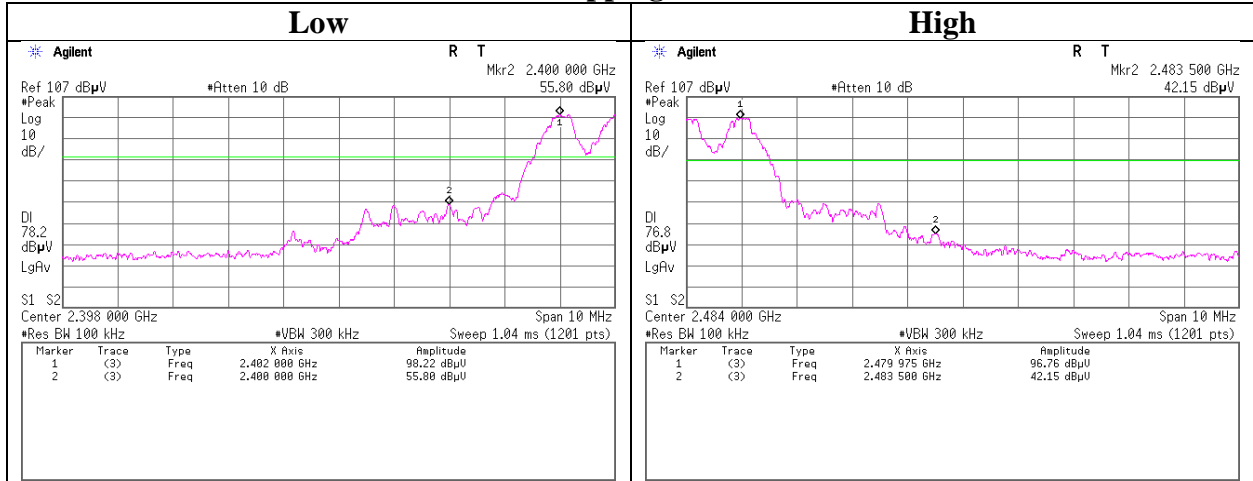

Hopping Off

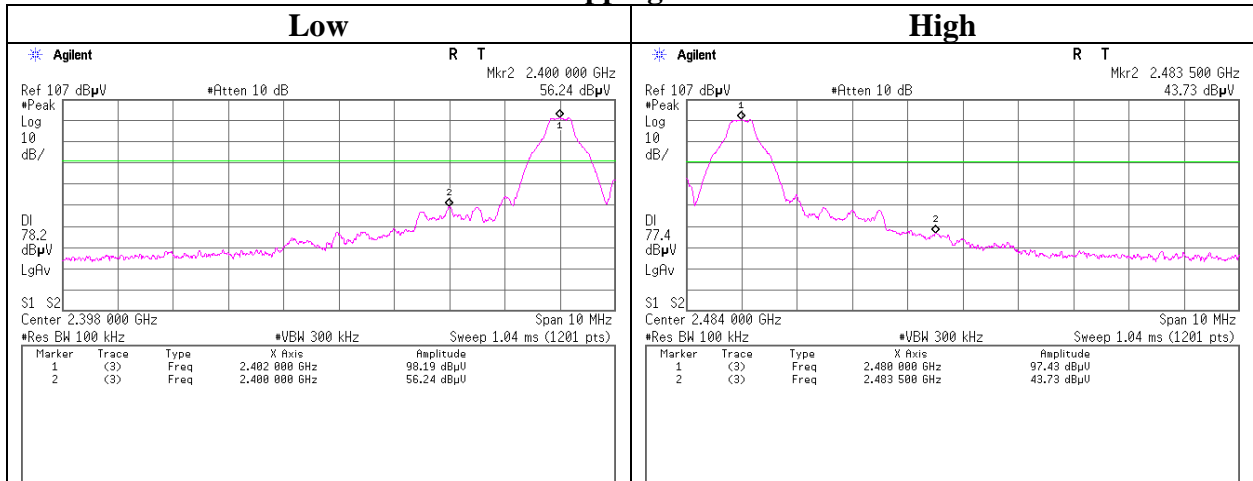

UL Japan, Inc.

Ise EMC Lab.

4383-326 Asama-cho, Ise-shi, Mie-ken 516-0021 JAPAN

Telephone : +81 596 24 8999

Facsimile : +81 596 24 8124

99% Occupied Bandwidth

Test place	Ise EMC Lab. No.11 Measurement Room
Report No.	11047825H
Date	November 13, 2015
Temperature / Humidity	24 deg. C / 58 % RH
Engineer	Takumi Shimada
Mode	Tx Hopping Off

Hopping Off, DH5

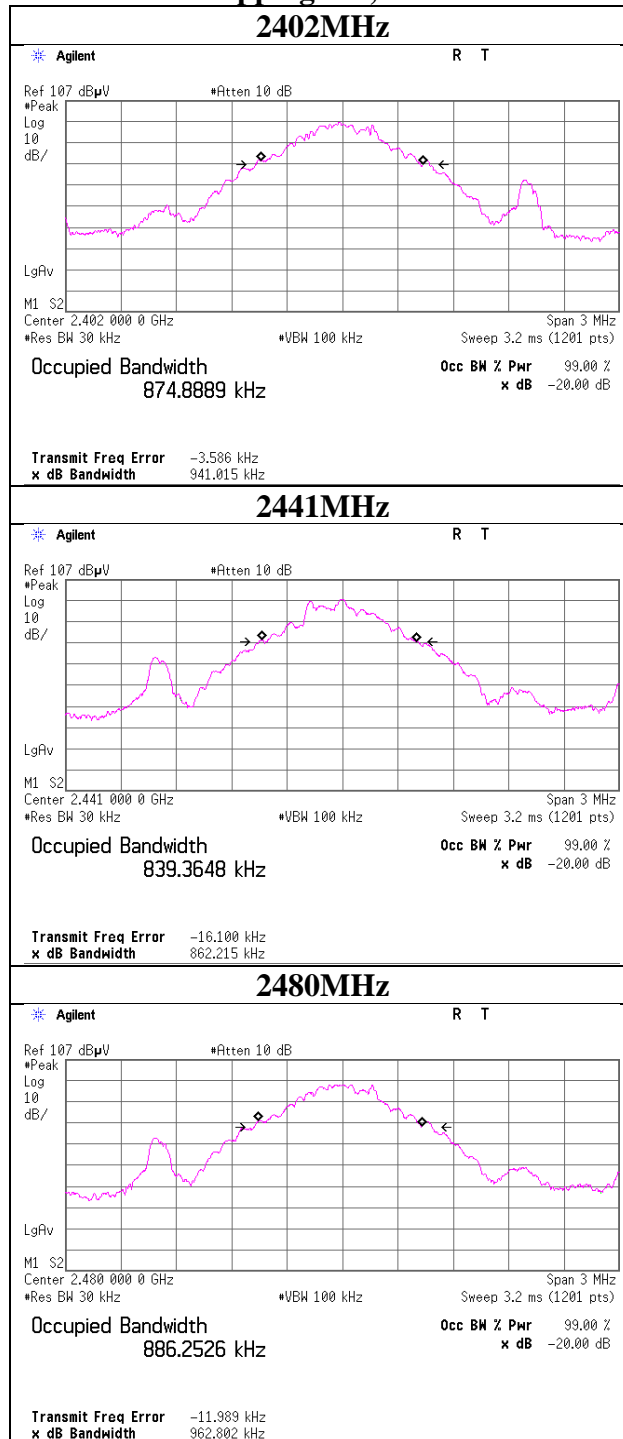

UL Japan, Inc.

Ise EMC Lab.

4383-326 Asama-cho, Ise-shi, Mie-ken 516-0021 JAPAN

Telephone : +81 596 24 8999

Facsimile : +81 596 24 8124

99% Occupied Bandwidth

Test place Ise EMC Lab. No.11 Measurement Room
Report No. 11047825H
Date November 13, 2015
Temperature / Humidity 24 deg. C / 58 % RH
Engineer Takumi Shimada
Mode Tx Hopping On

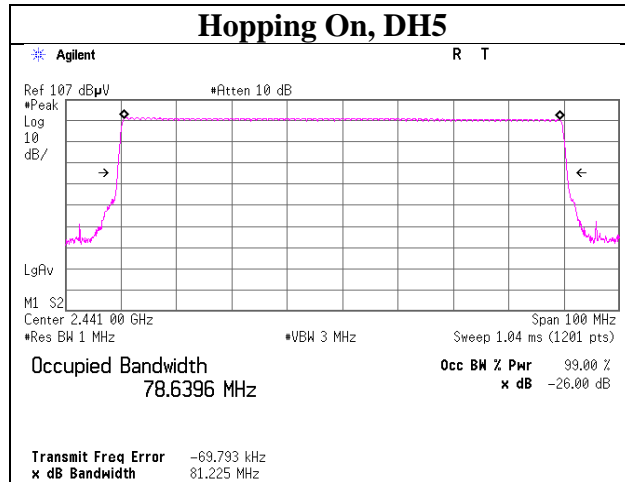

APPENDIX 2: Test instruments

Test equipment

Control No.	Instrument	Manufacturer	Model No	Serial No	Test Item	Calibration Date * Interval(month)
MAEC-04	Semi Anechoic Chamber(NSA)	TDK	Semi Anechoic Chamber 3m	DA-10005	RE/CE	2015/10/02 * 12
MOS-15	Thermo-Hygrometer	Custom	CTH-180	1501	RE/CE	2015/01/13 * 12
MJM-26	Measure	KOMELON	KMC-36	-	RE/CE	-
COTS-MEMI	EMI measurement program	TSJ	TEPTO-DV	-	RE/CE	-
MSA-13	Spectrum Analyzer	Agilent	E4440A	MY46185823	RE	2015/06/02 * 12
MHA-21	Horn Antenna 1-18GHz	Schwarzbeck	BBHA9120D	9120D-557	RE	2015/08/10 * 12
MCC-167	Microwave Cable	Junkosha	MWX221	1404S374 (1m) / 1405S074(5m)	RE	2015/05/21 * 12
MPA-12	MicroWave System Amplifier	Agilent	83017A	00650	RE	2015/10/01 * 12
MHF-26	High Pass Filter 3.5-18.0GHz	UL Japan	HPF SELECTOR	002	RE	2015/09/17*12
MMM-10	DIGITAL HiTESTER	Hioki	3805	051201148	RE/CE	2015/01/16 * 12
MHA-17	Horn Antenna 15-40GHz	Schwarzbeck	BBHA9170	BBHA9170307	RE	2015/06/06 * 12
MTR-01	Test Receiver	Rohde & Schwarz	ESI40	100084	RE/CE	2014/11/10 * 12
MBA-05	Biconical Antenna	Schwarzbeck	BBA9106	1302	RE	2015/11/02 * 12
MLA-08	Logperiodic Antenna	Schwarzbeck	UKLP9140-A	N/A	RE	2015/11/03 * 12
MCC-50	Coaxial Cable	UL Japan	-	-	RE	2015/06/19 * 12
MAT-68	Attenuator	Anritsu	MP721B	6200961025	RE	2015/11/12 * 12
MPA-14	Pre Amplifier	SONOMA INSTRUMENT	310	260833	RE	2015/03/09 * 12
MLS-23	LISN(AMN)	Schwarzbeck	NSLK8127	8127-729	CE(EUT)	2015/07/10 * 12
MLS-24	LISN(AMN)	Schwarzbeck	NSLK8127	8127-730	CE(AE)	2015/07/10 * 12
MTA-31	Terminator	TME	CT-01	-	CE	2015/01/19 * 12
MAT-67	Attenuator	JFW Industries, Inc.	50FP-013H2 N	-	CE	2015/01/29 * 12
MCC-113	Coaxial cable	Fujikura/Suhner/TSJ	5D-2W(10m)/SFM141(5m)/421-010(1m)/ sucoform141-PE(1m)/ RFM-E121(Switcher)	-/04178	CE	2015/07/02 * 12
MSA-14	Spectrum Analyzer	Agilent	E4440A	MY48250080	AT	2015/10/07 * 12
MCC-171	Microwave Cable	Junkosha	MWX221	1409S494	AT	2015/03/04 * 12
MPM-09	Power Meter	Anritsu	ML2495A	6K00003348	AT	2015/10/19 * 12
MPSE-12	Power sensor	Anritsu	MA2411B	011598	AT	2015/10/19 * 12
MOS-19	Thermo-Hygrometer	Custom	CTH-201	0001	AT	2014/12/22 * 12

The expiration date of the calibration is the end of the expired month.

All equipment is calibrated with valid calibrations. Each measurement data is traceable to the national or international standards.

As for some calibrations performed after the tested dates, those test equipment have been controlled by means of an unbroken chains of calibrations.

Test Item: CE: Conducted Emission test
 RE: Radiated Emission test
 AT: Antenna Terminal Conducted test

UL Japan, Inc.

Ise EMC Lab.

4383-326 Asama-cho, Ise-shi, Mie-ken 516-0021 JAPAN

Telephone : +81 596 24 8999

Facsimile : +81 596 24 8124