

Zhejiang Kezheng Electronic Product Inspection

Building 5, No. 316, Jianghong South Road Binjiang District, Hangzhou 310052, China
TEL: +86-571-88366800

TEST REPORT



Report No.: **2019-9015**
FCC ID.....: **REY-FDW020**
Applicant.....: SKYRC Technology Co.,Ltd.
Address.....: 4,5,8/F, Building No.4, Meitai Science Park, Guanguang South Road, Guihua, Guanlan, Longhua District, Shenzhen 518110, China
Manufacturer.....: SKYRC Technology Co.,Ltd.
Address.....: 4,5,8/F, Building No.4, Meitai Science Park, Guanguang South Road, Guihua, Guanlan, Longhua District, Shenzhen 518110, China
Product Name.....: **Smart Pet Feeder with Camera**
Trade Mark.....: PETONEER
Model/Type reference.....: FDW020
Listed Model(s): N/A
Standard.....: **FCC CFR Title 47 Part 15 Subpart C Section 15.247**
Date of receipt of test sample...: May 13, 2019
Date of testing.....: May 13, 2019 to May 28, 2019
Date of issue.....: May 28, 2019
Result.....: **PASS**

Compiled by:
(Printed name+signature) Liu Wei 
Supervised by:
(Printed name+signature) Chen Yiyun 
Approved by:
(Printed name+signature) Wang Weixiong 

Testing Laboratory Name **Zhejiang Kezheng Electronic Product Inspection**
Address..... Building 5, No. 316, Jianghong South Road Binjiang District,
Hangzhou 310052, China

This test report may be duplicated completely for legal use with the approval of the applicant. It should not be reproduced except in full, without the written approval of our laboratory. The client should not use it to claim product endorsement by Kezheng. The test results in the report only apply to the tested sample. The test report shall be invalid without all the signatures of testing engineers, reviewer and approver. Any objections must be raised to Kezheng within 15 days since the date when the report is received. It will not be taken into consideration beyond this limit. The test report merely correspond to the test sample.

Table of Contents	Page
1. TEST SUMMARY	3
1.1. TEST STANDARDS	3
1.2. REPORT VERSION	3
1.3. TEST DESCRIPTION	4
1.4. MEASUREMENT UNCERTAINTY	5
1.5. ENVIRONMENTAL CONDITIONS.....	5
2. GENERAL INFORMATION.....	6
2.1. CLIENT INFORMATION.....	6
2.2. GENERAL DESCRIPTION OF EUT.....	6
2.3. OPERATION STATE	7
2.4. MEASUREMENT INSTRUMENTS LIST.....	8
3. TEST ITEM AND RESULTS	9
3.1. ANTENNA REQUIREMENT.....	9
3.2. CONDUCTED EMISSION	10
3.3. BANDWIDTH	13
3.4. PEAK OUTPUT POWER.....	26
3.5. POWER SPECTRAL DENSITY.....	28
3.6. BAND EDGE AND SPURIOUS EMISSION (CONDUCTED).....	35
3.7. BAND EDGE EMISSIONS.....	42
3.8. SPURIOUS EMISSION (RADIATED)	45
4. EUT TEST PHOTOS	53
5. PHOTOGRAPHS OF EUT CONSTRUCTIONAL.....	54

1. TEST SUMMARY

1.1. Test Standards

The tests were performed according to following standards:

[FCC Rules Part 15.247](#): Operation within the bands of 902-928MHz, 2400-2483.5MHz, and 5725-5850MHz.

[ANSI C63.10-2013](#): American National Standard for Testing Unlicensed Wireless Devices.

1.2. Report version

Revised No.	Date of issue	Description
01	May 28, 2019	Original

1.3. Test Description

FCC Part 15 Subpart C(15.247)			
Test Item	Standard Section	Result	Test Engineer
	FCC		
Antenna Requirement	15.203	Pass	John Xie
Conducted Emission	15.207	Pass	John Xie
6dB Bandwidth	15.247(a)(2)	Pass	John Xie
Peak Output Power	15.247(b)	Pass	John Xie
Power Spectral Density	15.247(e)	Pass	John Xie
Restricted Band	15.247(d)/15.205	Pass	John Xie
Band Edge and Spurious Emission(Conducted)	15.247(d)	Pass	John Xie
Spurious Emission(Radiated)	15.247(d)&15.209	Pass	John Xie

Note: The measurement uncertainty is not included in the test result.

1.4. Measurement Uncertainty

The data and results referenced in this document are true and accurate. The reader is cautioned that there may be errors within the calibration limits of the equipment and facilities. The measurement uncertainty was calculated for all measurements listed in this test report acc. to TR-100028-01 "Electromagnetic compatibility and Radio spectrum Matters (ERM);Uncertainties in the measurement of mobile radio equipment characteristics; Part 1" and TR-100028-02 "Electromagnetic compatibility and Radio spectrum Matters (ERM);Uncertainties in the measurement of mobile radio equipment characteristics; Part 2 " and is documented in the Zhejiang Kezheng Electronic Product Inspection quality system acc. to DIN EN ISO/IEC 17025. Furthermore, component and process variability of devices similar to that tested may result in additional deviation. The manufacturer has the sole responsibility of continued compliance of the device. Below is the best measurement capability for Zhejiang Kezheng Electronic Product Inspection.

Test Items	Measurement Uncertainty	Notes
Transmitter power conducted	0.42 dB	(1)
Transmitter power Radiated	2.14 dB	(1)
Conducted spurious emissions 9kHz~40GHz	1.60 dB	(1)
Radiated spurious emissions 9kHz~40GHz	2.20 dB	(1)
Conducted Emissions 9kHz~30MHz	3.20 dB	(1)
Radiated Emissions 30~1000MHz	4.70 dB	(1)
Radiated Emissions 1~18GHz	5.00 dB	(1)
Radiated Emissions 18~40GHz	5.54 dB	(1)
Occupied Bandwidth	-----	(1)

Note (1): This uncertainty represents an expanded uncertainty expressed at approximately the 95% confidence level using a coverage factor of $k=1.96$.

1.5. Environmental conditions

During the measurement the environmental conditions were within the listed ranges:

Temperature:	15~35°C
Relative Humidity:	30~60 %
Air Pressure:	950~1050mba

2. GENERAL INFORMATION

2.1. Client Information

Applicant:	SKYRC Technology Co.,Ltd.
Address:	4,5,8/F, Building No.4, Meitai Science Park, Guanguang South Road, Guihua, Guanlan, Longhua District, Shenzhen 518110, China
Manufacturer:	SKYRC Technology Co.,Ltd.
Address:	4,5,8/F, Building No.4, Meitai Science Park, Guanguang South Road, Guihua, Guanlan, Longhua District, Shenzhen 518110, China

2.2. General Description of EUT

Product Name:	Smart Pet Feeder with Camera
Model/Type reference:	FDW020
Marketing Name:	N/A
Listed Model(s):	N/A
Power supply:	DC 5V 2000mA
Adapter :	Model:A122-0502000PB Input:100-240V 50/60Hz 0.4A Output: DC5V 2000mA
Hardware version:	F6021-V1.0
Software version:	N/A
WIFI 802.11b/g/n(HT20)	
Modulation:	802.11b: DSSS(CCK, DQPSK, DBPSK) 802.11g/n: OFDM(BPSK,QPSK,16QAM,64QAM)
Operation frequency:	802.11b/g/n(HT20): 2412MHz~2462MHz
Max Peak Output Power:	802.11b: 13.88dBm 802.11g: 9.62dBm 802.11n (HT20): 9.64dBm
Channel number:	802.11b/g/n(HT20):11 channels
Channel separation:	5MHz
Antenna type:	PCB Antenna
Antenna gain:	2dBi

2.3. Operation state

Operation Frequency List: The EUT has been tested under typical operating condition. The Applicant provides communication tools software to control the EUT for staying in continuous transmitting and receiving mode for testing.

Operation Frequency List:

Channel	Frequency (MHz)
00	2412
01	2417
02	2422
03	2427
04	2432
05	2437
06	2442
07	2447
08	2452
09	2457
10	2462

Note: CH 00~CH 10 for 802.11b/g/n(HT20).

Test mode

For RF test items
The engineering test program was provided and enabled to make EUT continuous transmit (duty cycle>98%).
For AC power line conducted emissions:
The EUT was set to connect with the WLAN AP under large package sizes transmission.
For Radiated suprious emissions test item:
The engineering test program was provided and enabled to make EUT continuous transmit(duty cycle>98%). The EUT in each of three orthogonal axis emissions had been tested ,but only the worst case (X axis) data Recorded in the report.

2.4. Measurement Instruments List

Tonscend JS0806-2 Test system					
Item	Test Equipment	Manufacturer	Model No.	Serial No.	Cal. Until
1	Spectrum Analyzer	Rohde & Schwarz	FUV40-N	101798	Dec. 22, 2019
2	MXG Analog Signal Generator	Agilent	N5182A	MY50142520	Dec. 22, 2019
3	Signal Generator	HP	83752A	3344A00337	Dec. 22, 2019
4	Wideband Radio Communication Tester	Rohde & Schwarz	CMW500	157282	Dec. 22, 2019
5	Climate Chamber	Angui	AGNH80 L	1903042120	Dec. 22, 2019
6	300328 v2.1.1 test system	JS0806-2	/	/	Dec. 22, 2019

Item	Test Equipment	Manufacturer	Model No.	Serial No.	Calibrated until
1	EMI Test Receiver	Rohde & Schwarz	ESR	102525	Dec. 22, 2019
2	High pass filter	Chengdu oulitong	BSF	/	Dec. 22, 2019
3	Log-Bicon Antenna	Schwarzbeck	VULB 9163	01230	Dec. 22, 2019
4	Ultra-Broadband Antenna	ShwarzBeck	BBHA 9120 D	2023	Dec. 22, 2019
6	Spectrum Analyzer	Keysight	9020A	MY46471971	Dec. 22, 2019
7	Horn Antenna	R&S	Sep-60	69483	Dec. 22, 2019
8	Pre-Amplifier	R&S	SCU-26	1003	Dec. 22, 2019
9	Pre-Amplifier	EMCI	EMC051835 SE	980662	Dec. 22, 2019

Note:1. The Cal. Interval was one year.

2. The cable loss has calculated in test result which connection between each test instruments.

3. TEST ITEM AND RESULTS

3.1. Antenna requirement

Requirement

FCC CFR Title 47 Part 15 Subpart C Section 15.203:

An intentional radiator shall be designed to ensure that no antenna other than that furnished by the responsible party shall be used with the device. The use of a permanently attached antenna or of an antenna that uses a unique coupling to the intentional radiator, the manufacturer may design the unit so that a broken antenna can be replaced by the user, but the use of a standard antenna jack or electrical connector is prohibited.

FCC CFR Title 47 Part 15 Subpart C Section 15.247(c) (1)(i):

(i) Systems operating in the 2400~2483.5 MHz band that is used exclusively for fixed. Point-to-point operations may employ transmitting antennas with directional gain greater than 6dBi provided the maximum conducted output power of the intentional radiator is reduced by 1 dB for every 3 dB that the directional gain of the antenna exceeds 6dBi.

Test Result

The directional gain of the antenna less than 6dBi, please refer to the EUT internal photographs antenna photo.

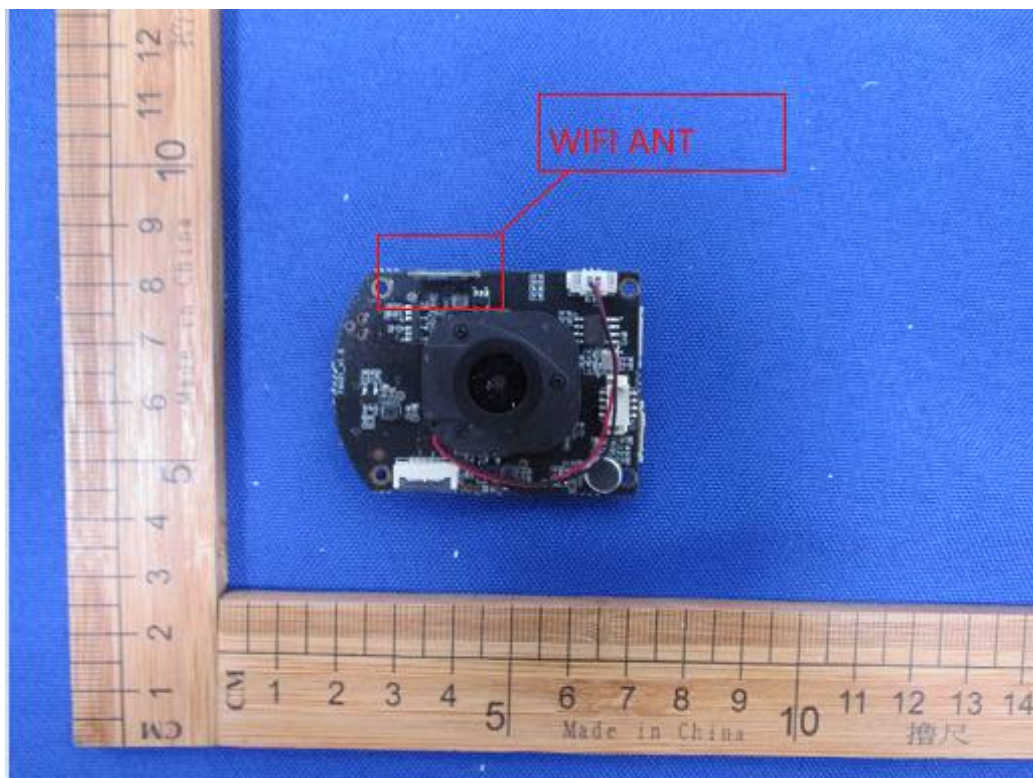

3.2. Conducted Emission

Limit

Conducted Emission Test Limit

Frequency	Maximum RF Line Voltage (dB μ V)	
	Quasi-peak Level	Average Level
150kHz~500kHz	66 ~ 56 *	56 ~ 46 *
500kHz~5MHz	56	46
5MHz~30MHz	60	50

Notes:

- (1) *Decreasing linearly with logarithm of the frequency.
- (2) The lower limit shall apply at the transition frequencies.
- (3) The limit decrease in line with the logarithm of the frequency in the range of 0.15 to 0.50MHz.

Test Configuration

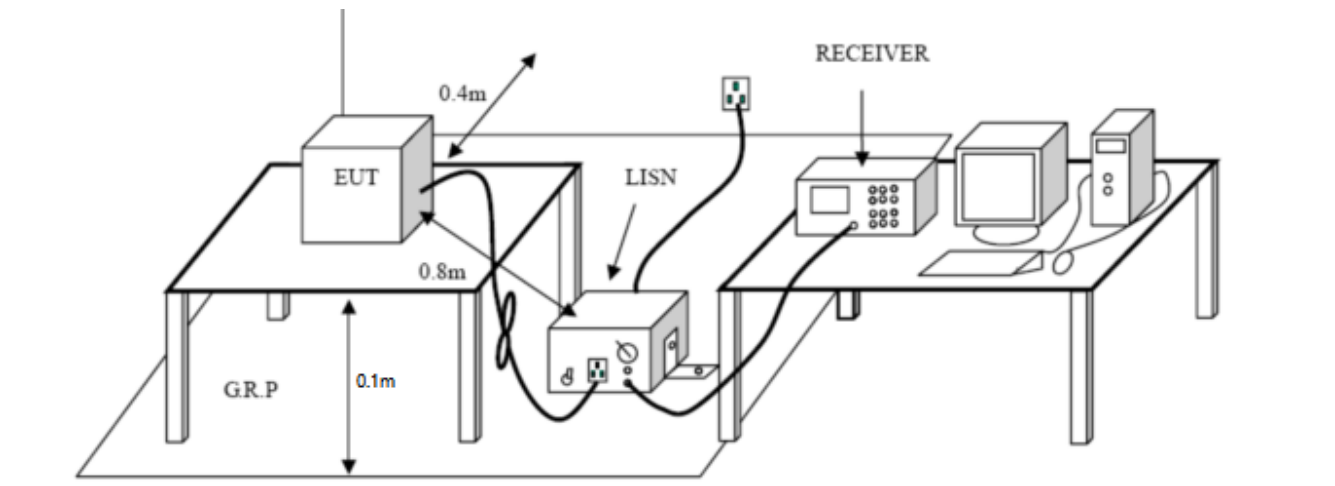

Test Procedure

1. The EUT was setup according to ANSI C63.10:2013 requirements.
2. The EUT was placed on a platform of nominal size, 1 m by 1.5 m, raised 80 cm above the conducting ground plane. The vertical conducting plane was located 40 cm to the rear of the EUT. All other surfaces of EUT were at least 0.1m from any other grounded conducting surface.
3. The EUT and simulators are connected to the main power through a line impedances stabilization network (LISN). The LISN provides a 50ohm /50uH coupling impedance for the measuring equipment. The peripheral devices are also connected to the main power through a LISN. (Please refer to the block diagram of the test setup and photographs)
4. Each current-carrying conductor of the EUT power cord, except the ground (safety) conductor, was individually connected through a LISN to the input power source.
5. The excess length of the power cord between the EUT and the LISN receptacle were folded back and forth at the center of the lead to form a bundle not exceeding 40 cm in length.
6. Conducted Emissions were investigated over the frequency range from 0.15MHz to 30MHz using a receiver bandwidth of 9 kHz.
7. During the above scans, the emissions were maximized by cable manipulation.

Test Mode:

Please refer to the clause 2.3.

Test Results

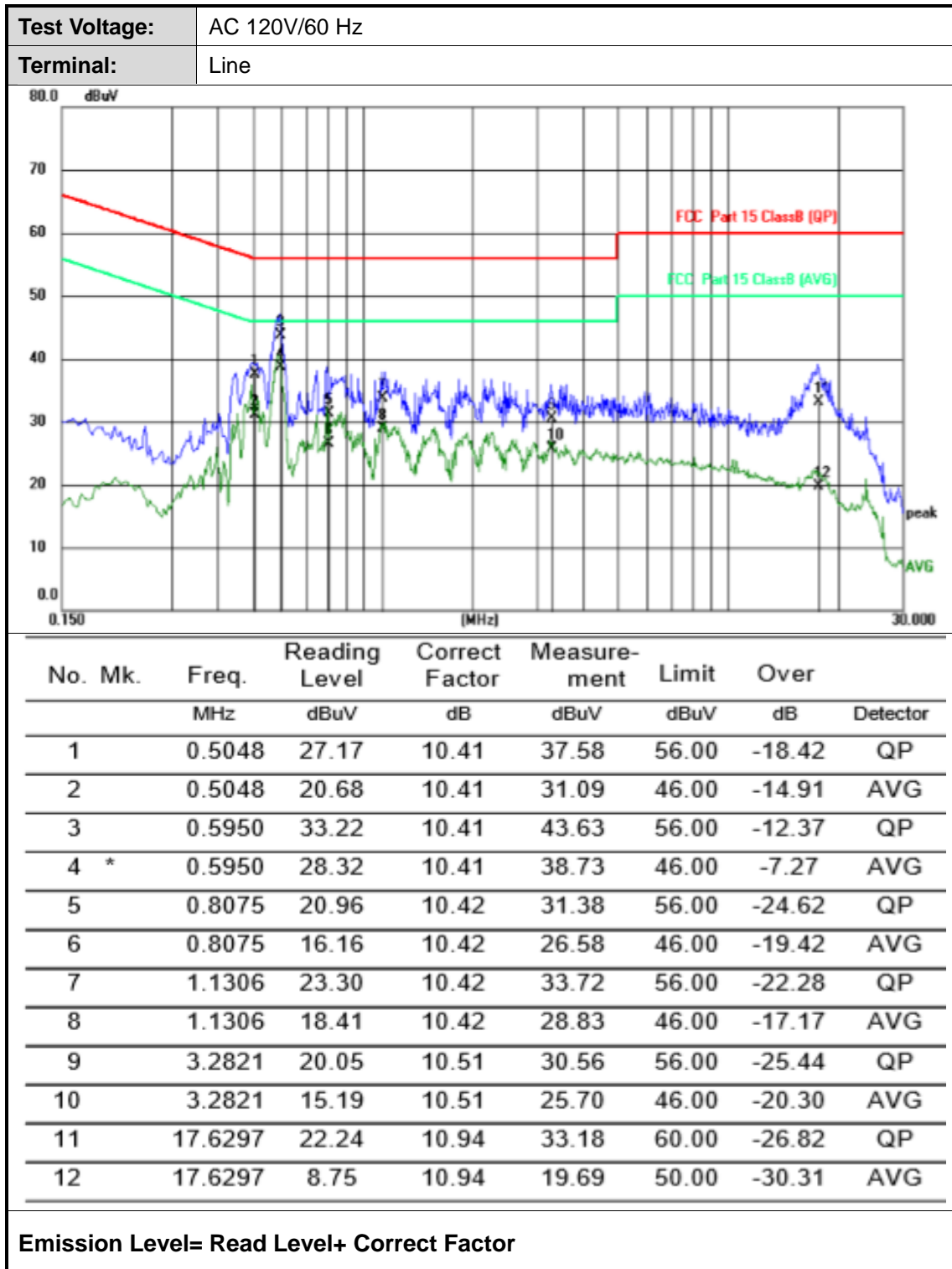

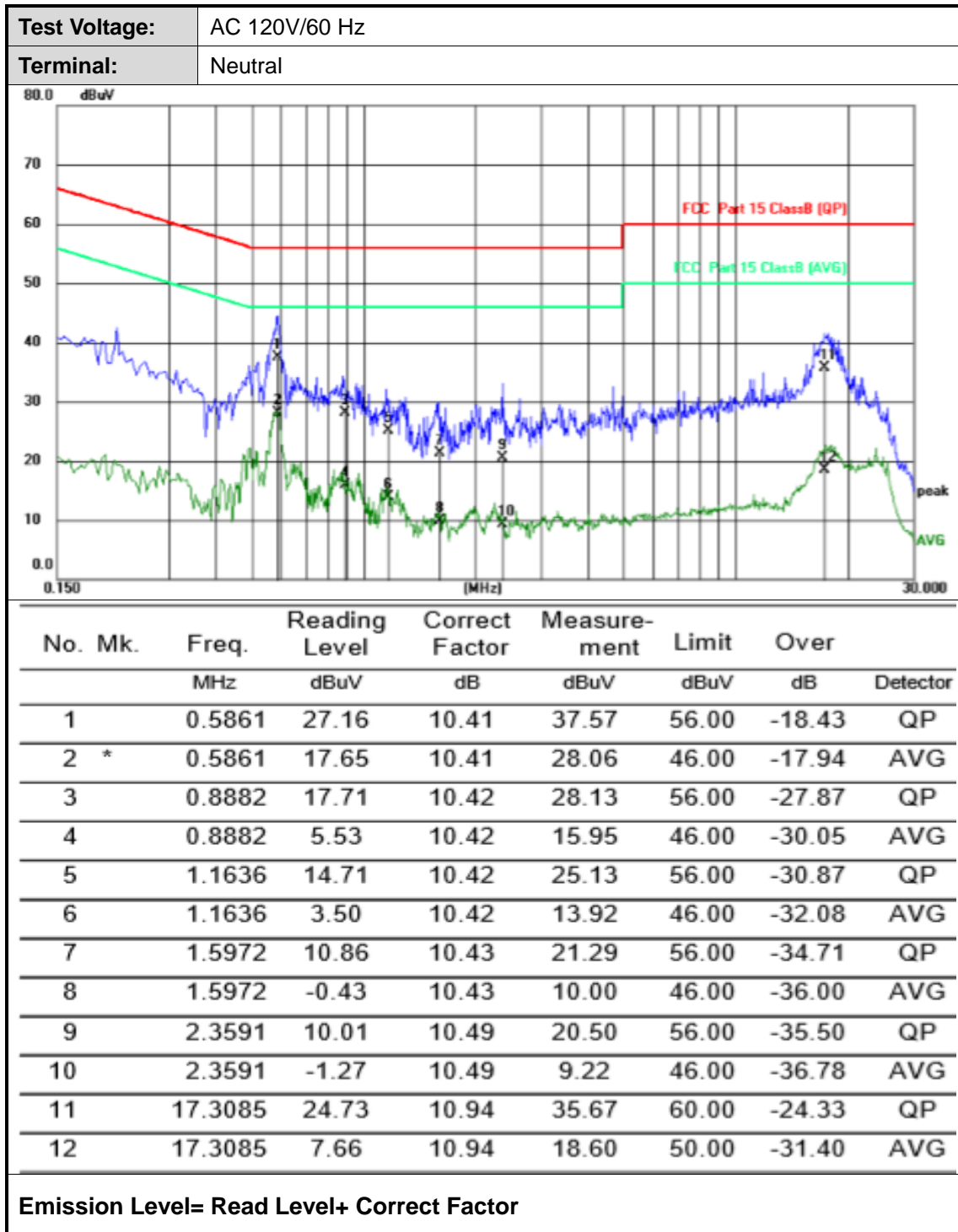

3.3. Bandwidth

Limit

Test Item	Limit	Frequency Range(MHz)
Bandwidth	≥ 500 KHz (6dB bandwidth)	2400~2483.5

Test Configuration

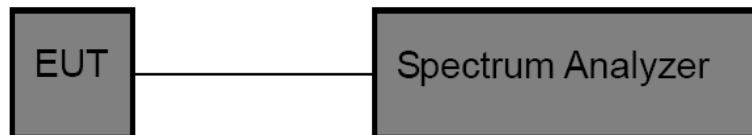

Test Procedure

1. The EUT was directly connected to the spectrum analyzer and antenna output port as show in the block diagram above.
2. Spectrum Setting:
 - (1) Set RBW = 100 kHz.
 - (2) Set the video bandwidth (VBW) ≥ 3 RBW.
 - (3) Detector = Peak.
 - (4) Trace mode = Max hold.
 - (5) Sweep = Auto couple.

NOTE: The EUT was set to continuously transmitting in each mode and low, Middle and high channel for the test.

Test Mode

Please refer to the clause 2.2.

Test Results

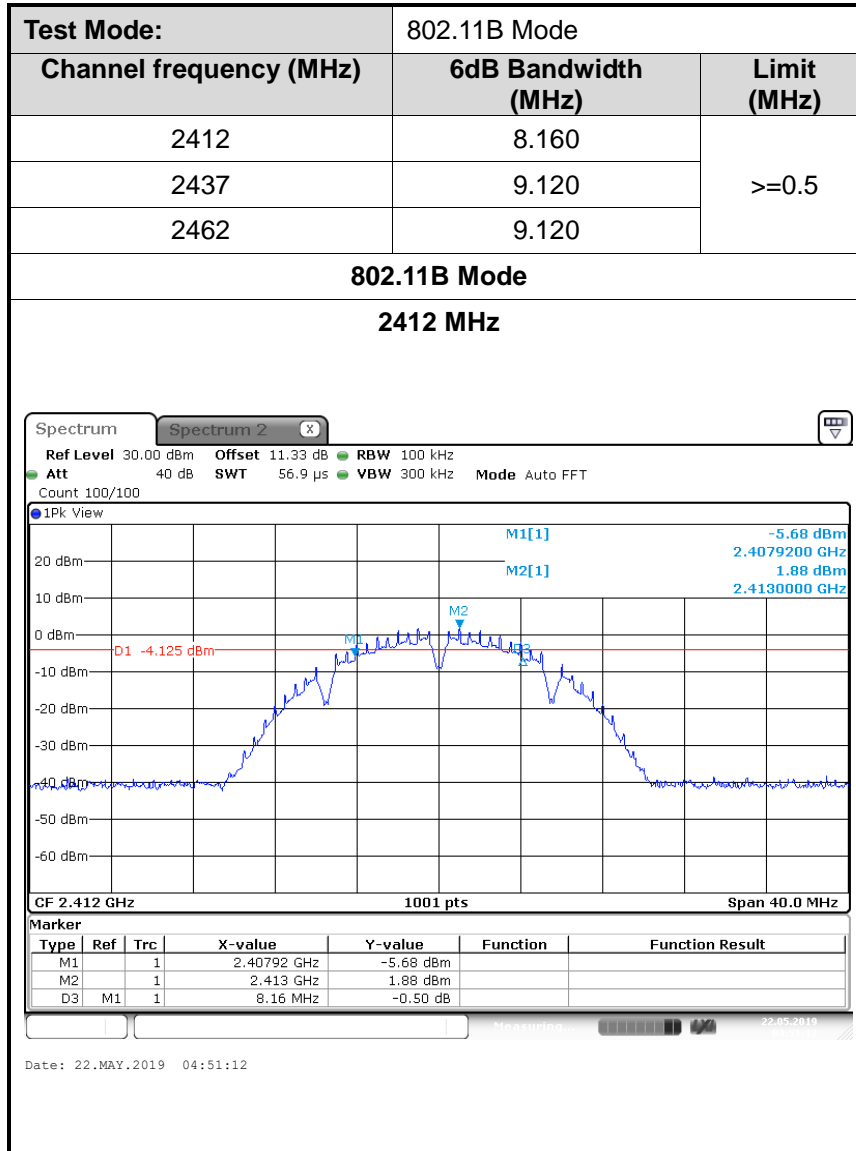

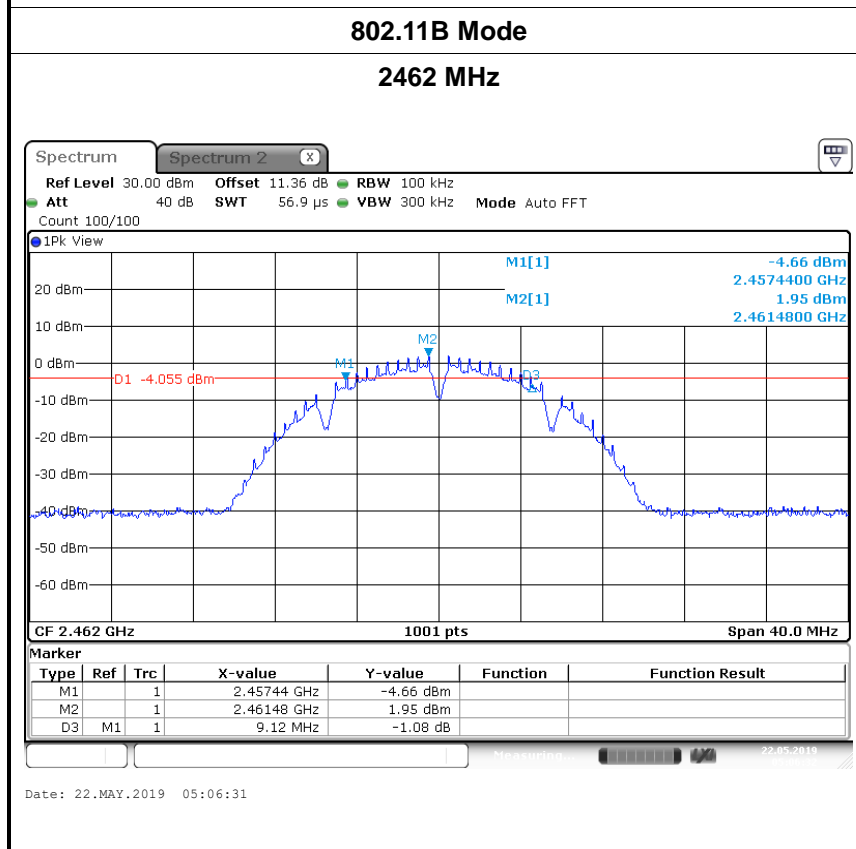
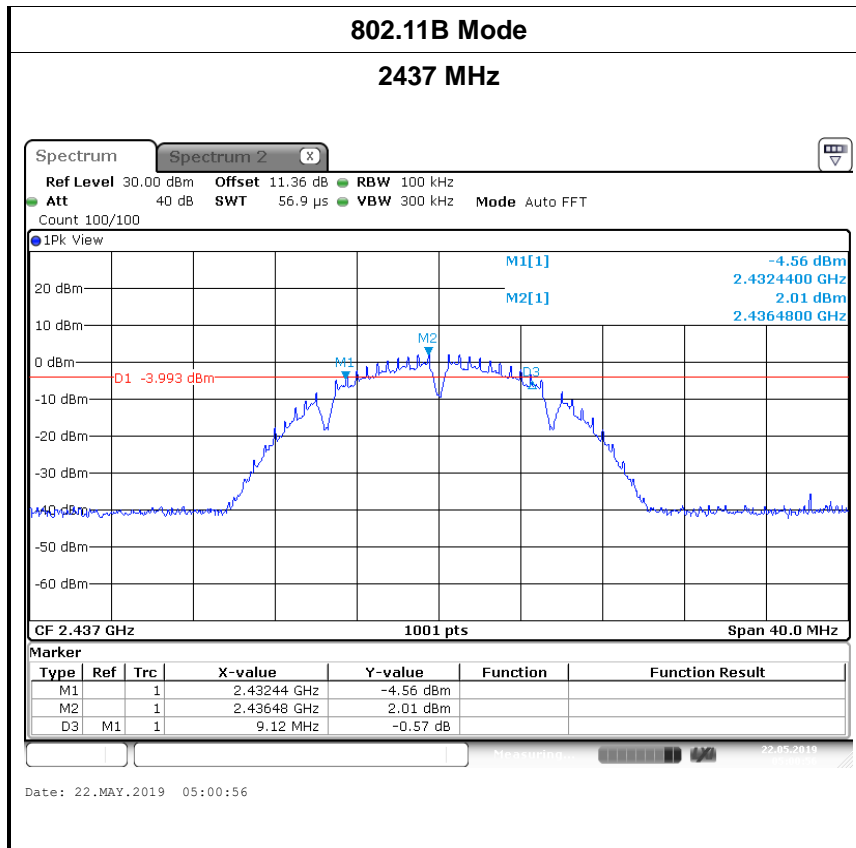

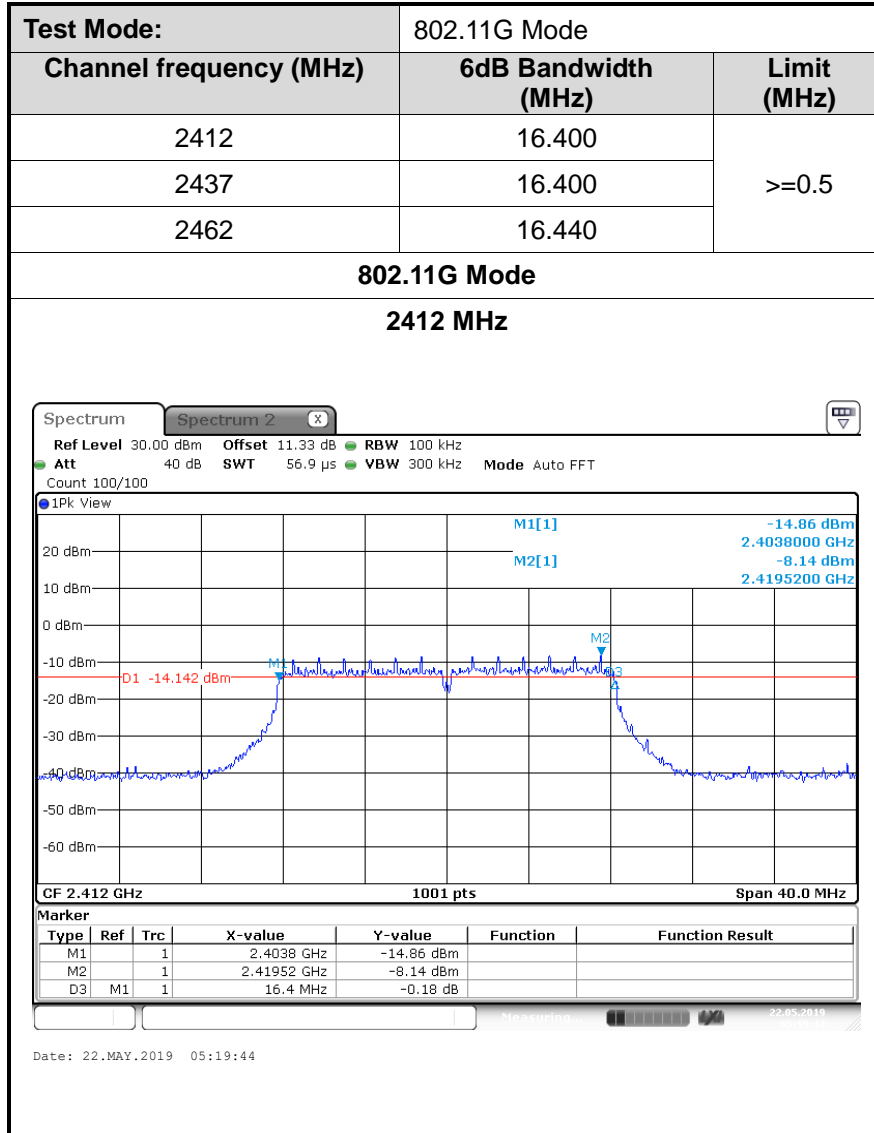

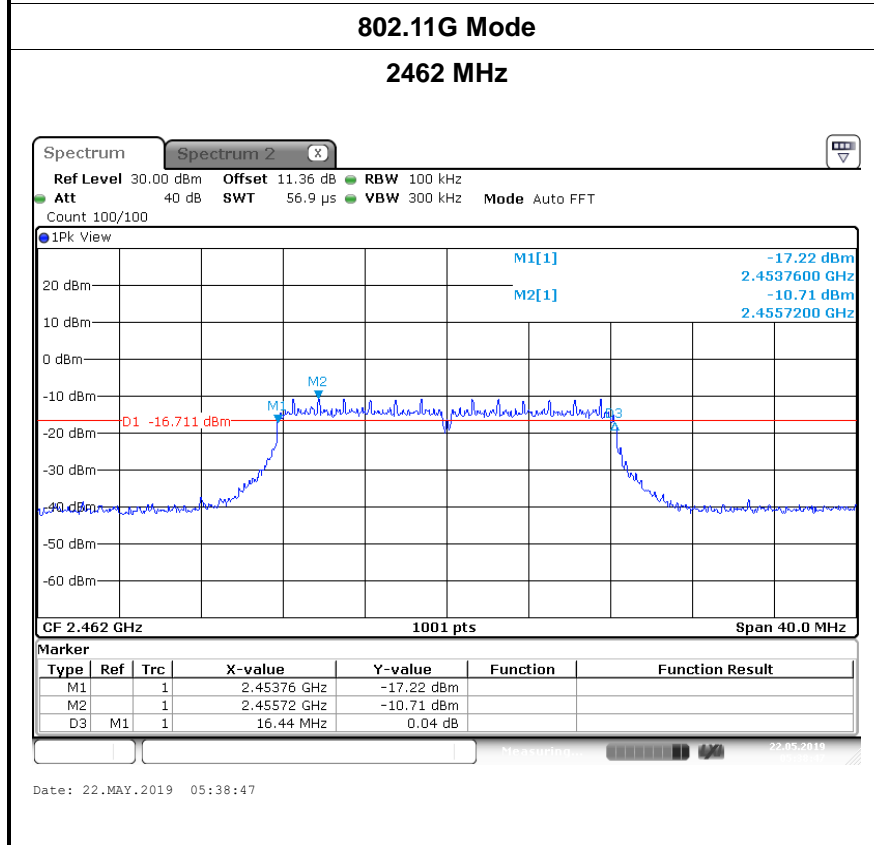
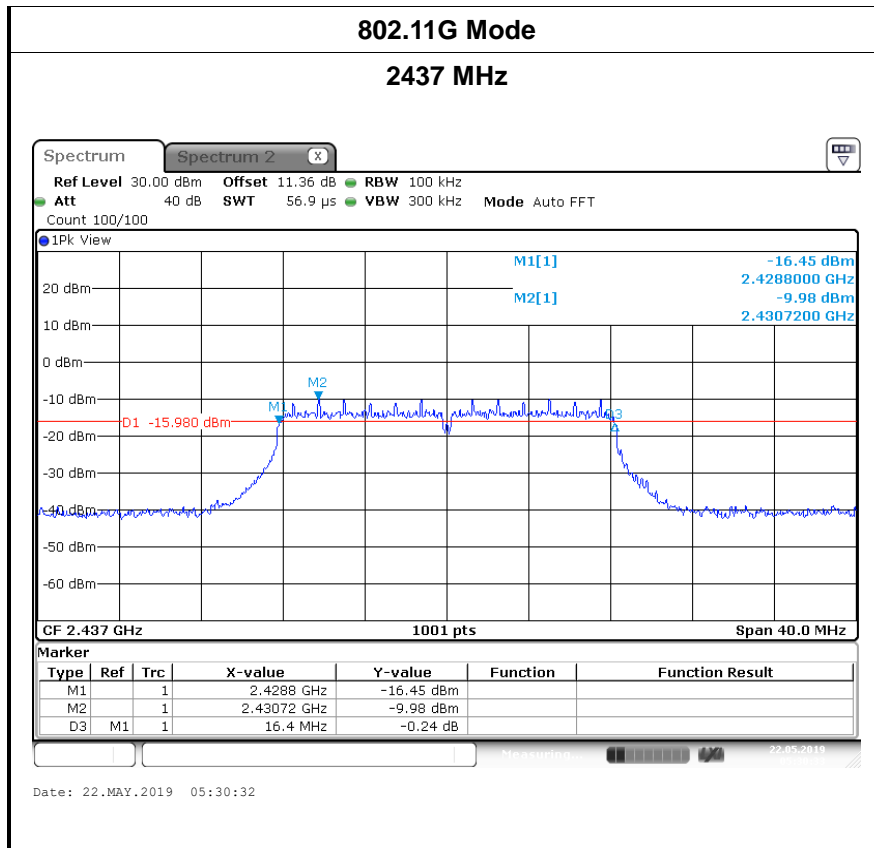

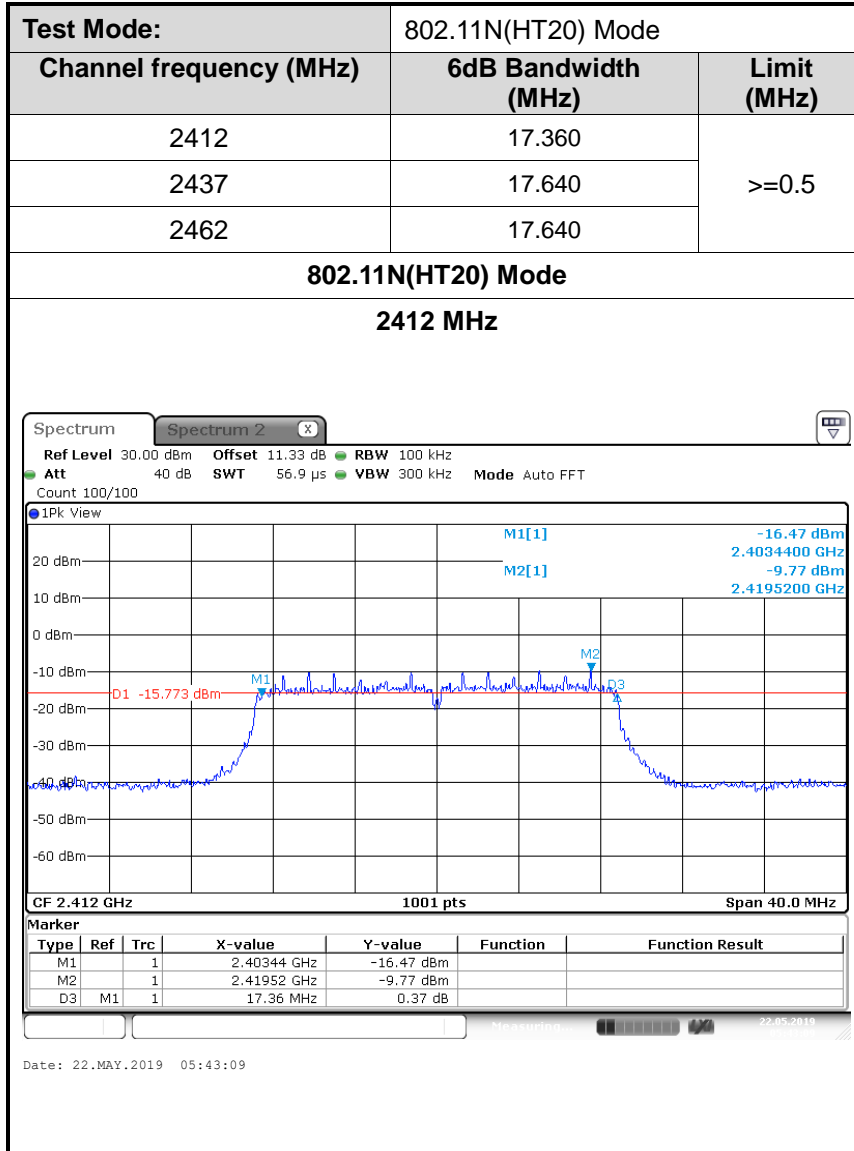

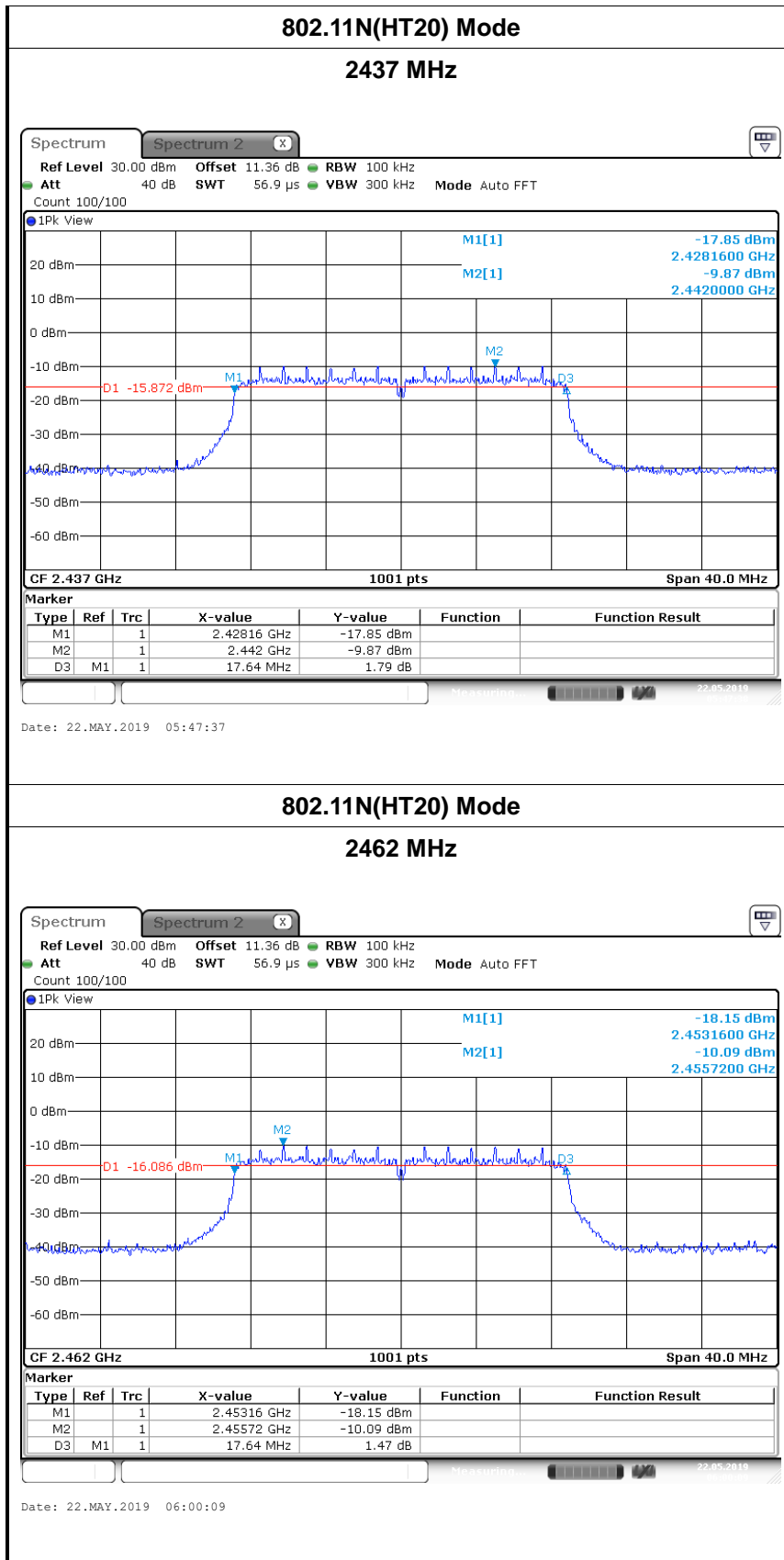

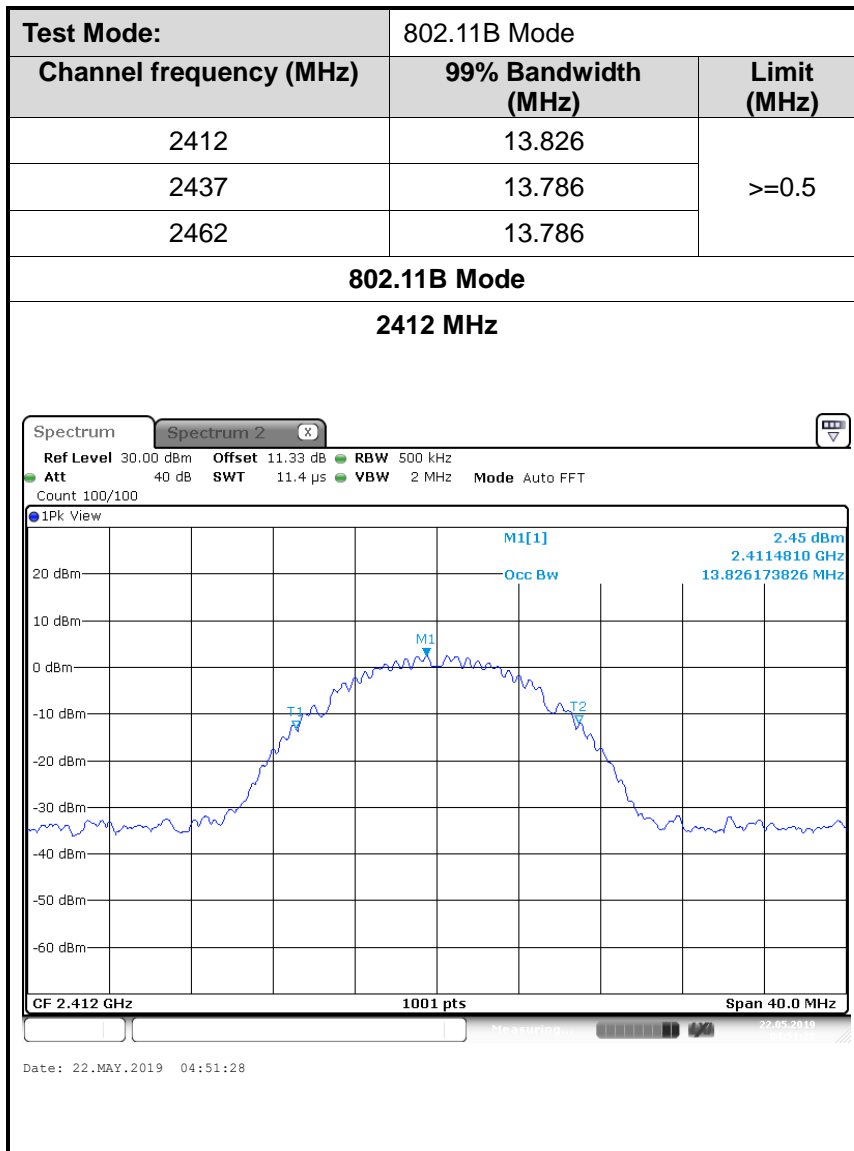

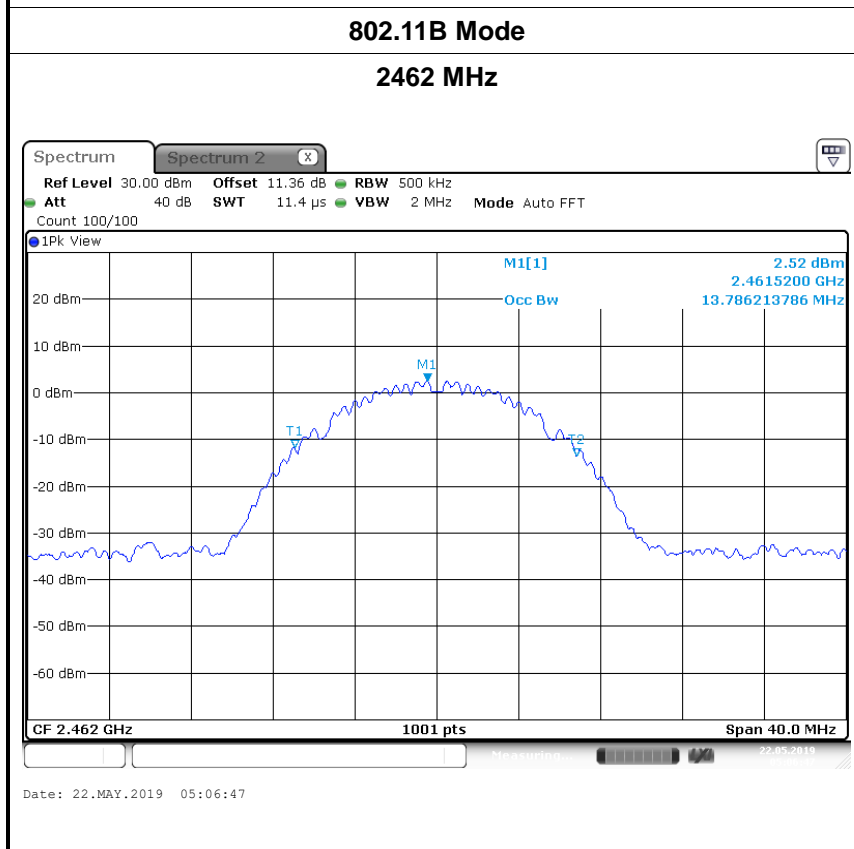
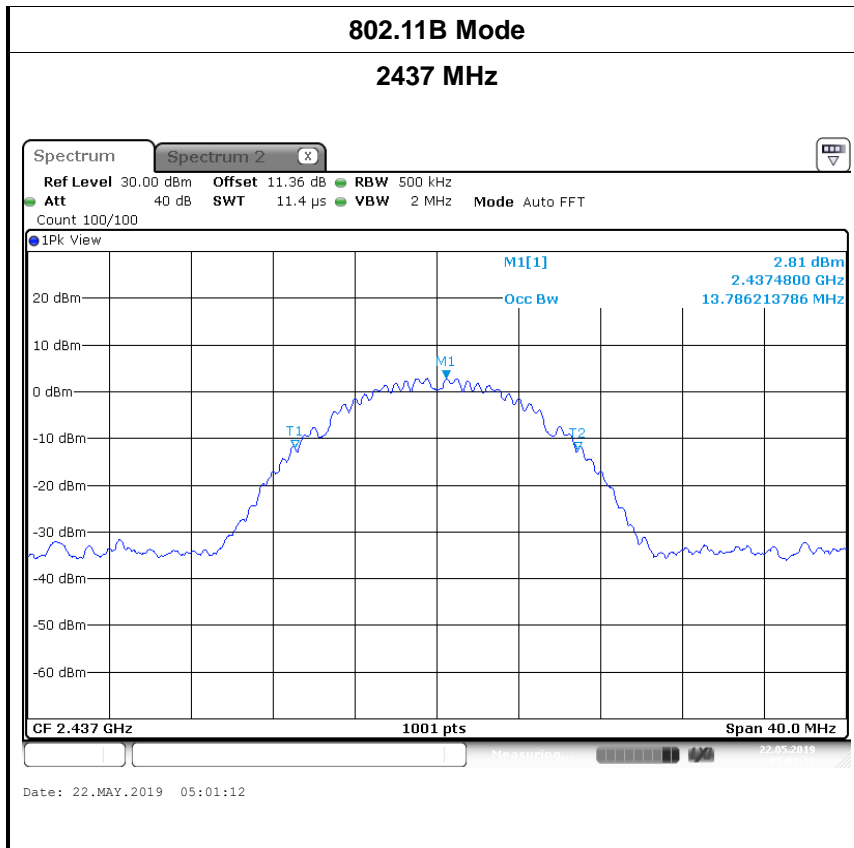

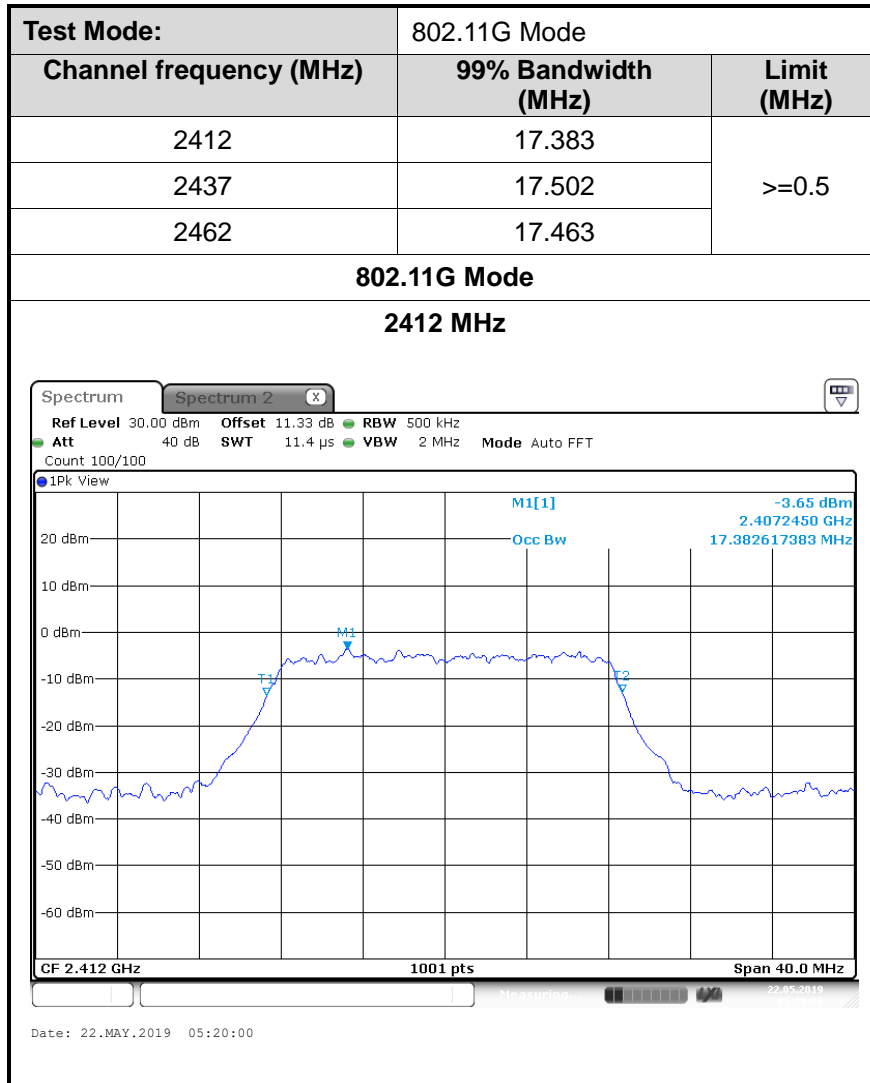

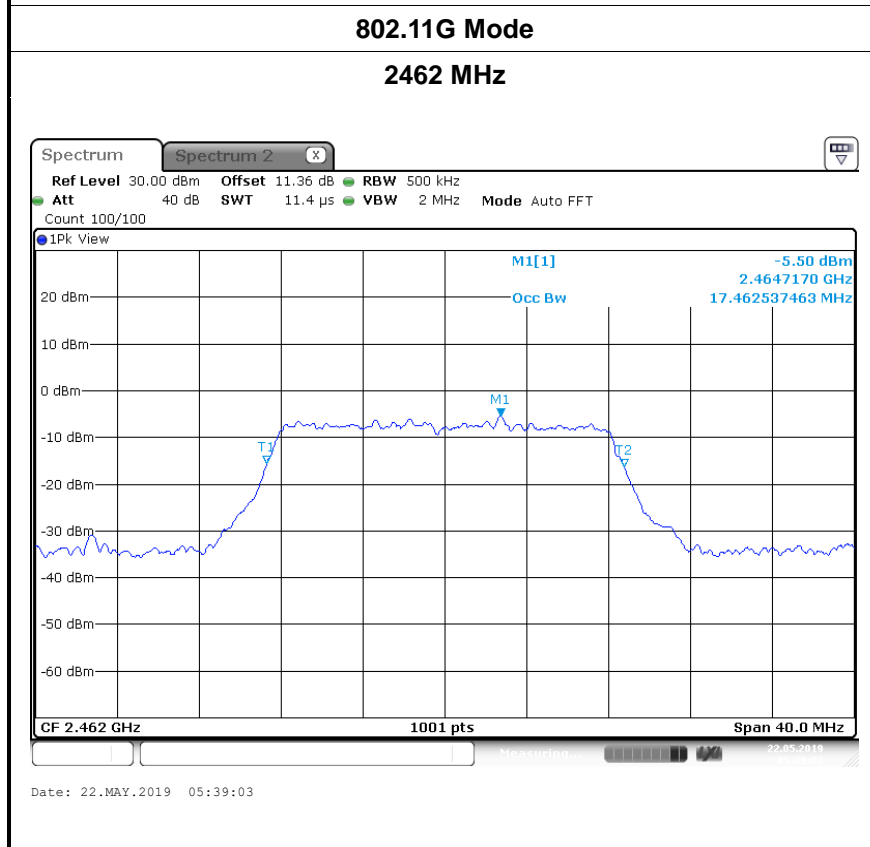
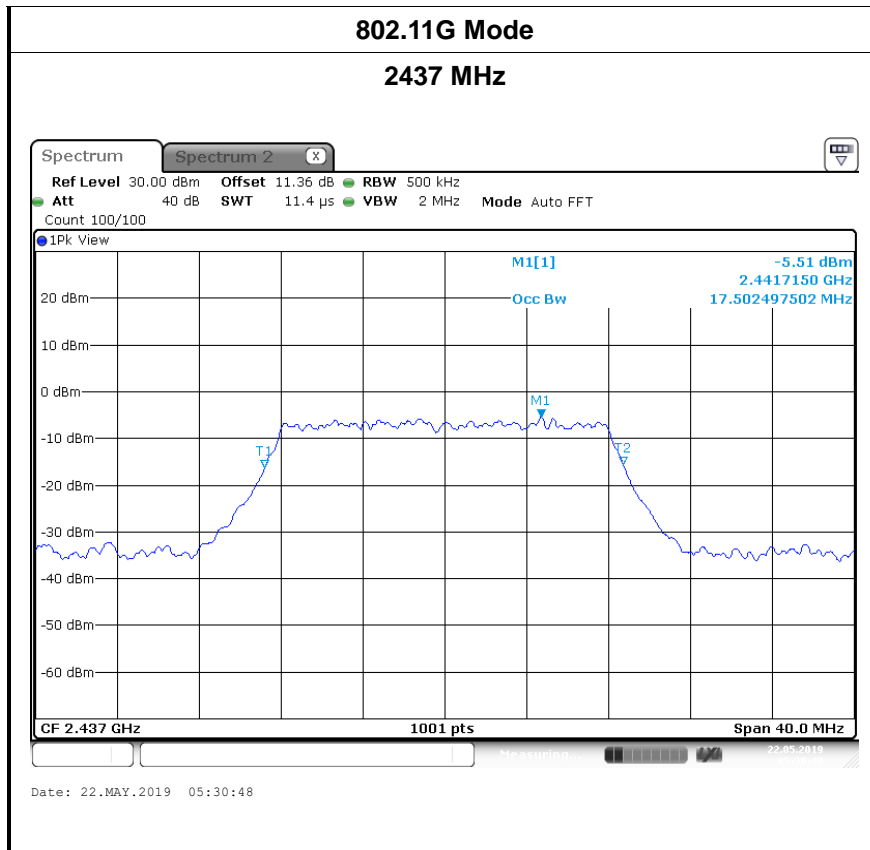



802.11N(HT20) Mode

2437 MHz

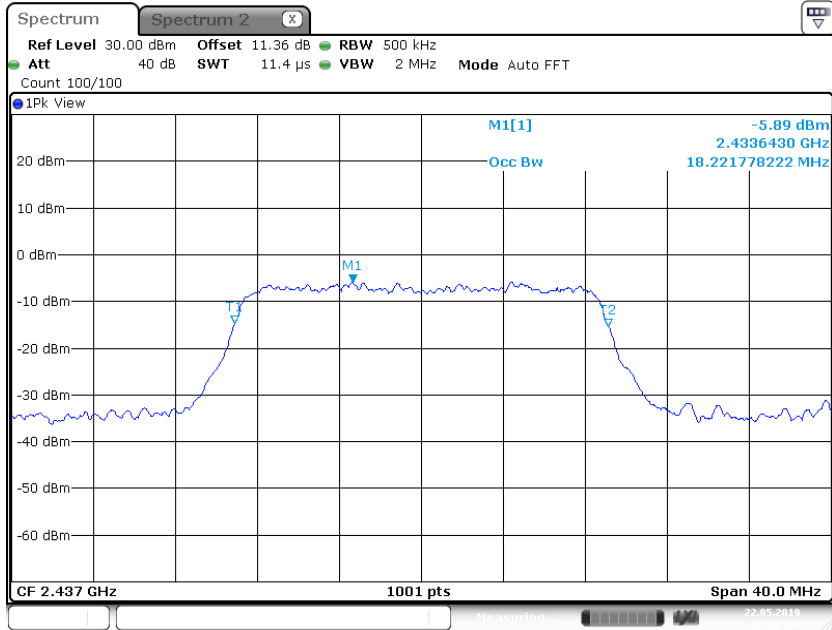

802.11N(HT20) Mode

2462 MHz

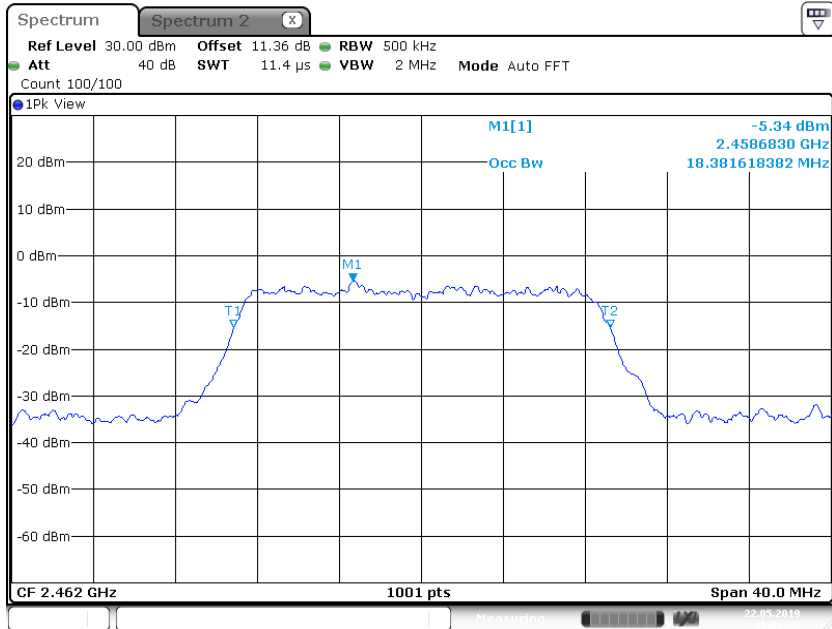

3.4. Peak Output Power

Limit

Test Item	Limit	Frequency Range(MHz)
Peak Output Power	1 Watt or 30 dBm	2400~2483.5

Test Configuration

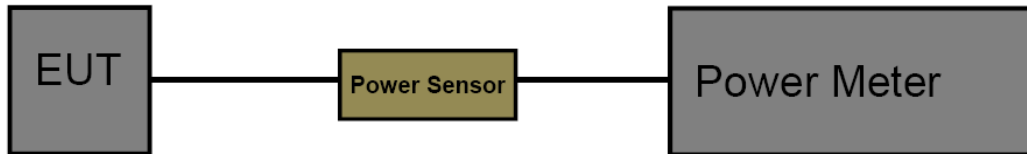

Test Procedure

1. The EUT was directly connected to the spectrum analyzer and antenna output port as show in the block diagram above.
2. The measurement is according to section 9.1.2 of KDB 558074 D01 15.247 DTS Meas Guidance v05.
3. Spectrum Setting:
Set analyser center frequency to DTS channel center frequency.
Set the RBW to: 1MHz
Set the VBW to: 3MHz
Detector: peak
Sweep time: auto
Allow trace to fully stabilize. Then use the peak marker function to determine the maximum amplitude level.
4. The power sensor video bandwidth is greater than or equal to the DTS bandwidth of the equipment.

Test Mode

Please refer to the clause 2.2

Test Result

Mode	Channel frequency (MHz)	Test Result (dBm)	Limit (dBm)
802.11b	2412	13.25	30
	2437	13.88	
	2462	13.54	
802.11g	2412	9.00	
	2437	9.62	
	2462	9.18	
802.11n (HT20)	2412	9.16	
	2437	9.64	
	2462	9.18	
Result : PASS			

3.5. Power Spectral Density

Limit

FCC Part 15 Subpart C(15.247)		
Test Item	Limit	Frequency Range(MHz)
Power Spectral Density	8dBm(in any 3 kHz)	2400~2483.5

Test Configuration

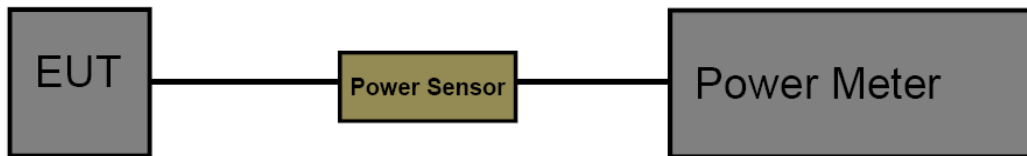

Test Procedure

1. The EUT was directly connected to the spectrum analyzer and antenna output port as show in the block diagram above.
2. The EUT was directly connected to the Spectrum Analyzer and antenna output port as show in the block diagram above. The measurement according to section 10.2 of KDB 558074 D01 15.247 DTS Meas Guidance v05.
3. Spectrum Setting:
 Set analyser center frequency to DTS channel center frequency.
 Set the span to 1.5 times the DTS bandwidth.
 Set the RBW to: 10 kHz
 Set the VBW to: 30 kHz
 Detector: peak
 Sweep time: auto
 Allow trace to fully stabilize. Then use the peak marker function to determine the maximum amplitude level.

Test Mode

Please refer to the clause 2.2

Test Result

Note:

Power Density(dBm/3kHz)=Power Density(dBm/10kHz)-10*Log(10/3)

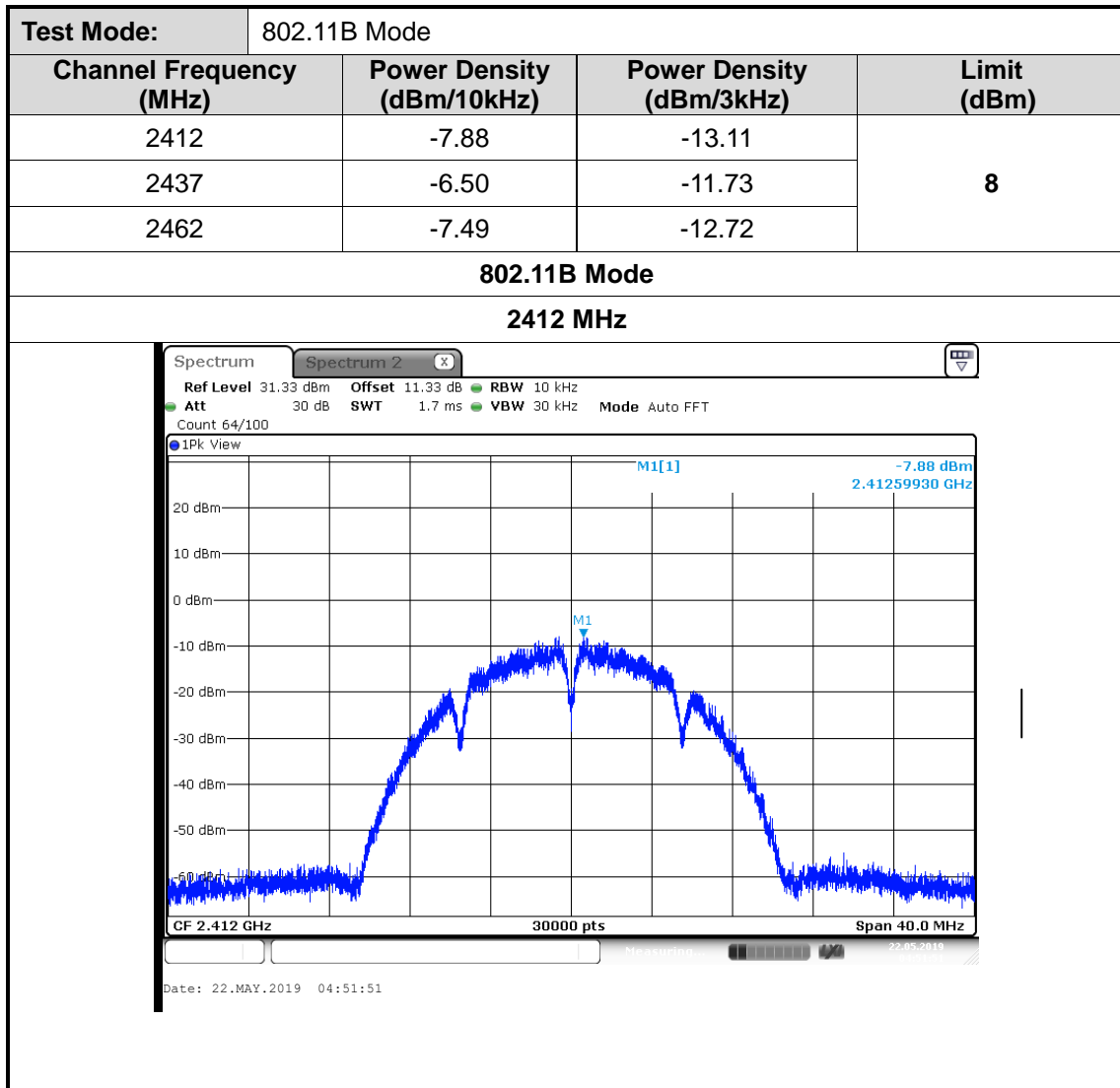

802.11B Mode

2437 MHz

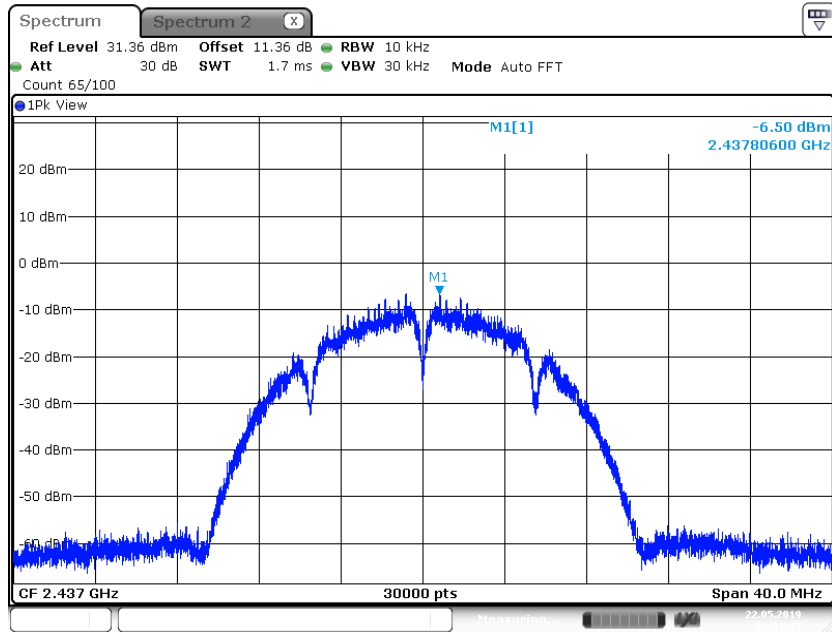

802.11B Mode

2462 MHz

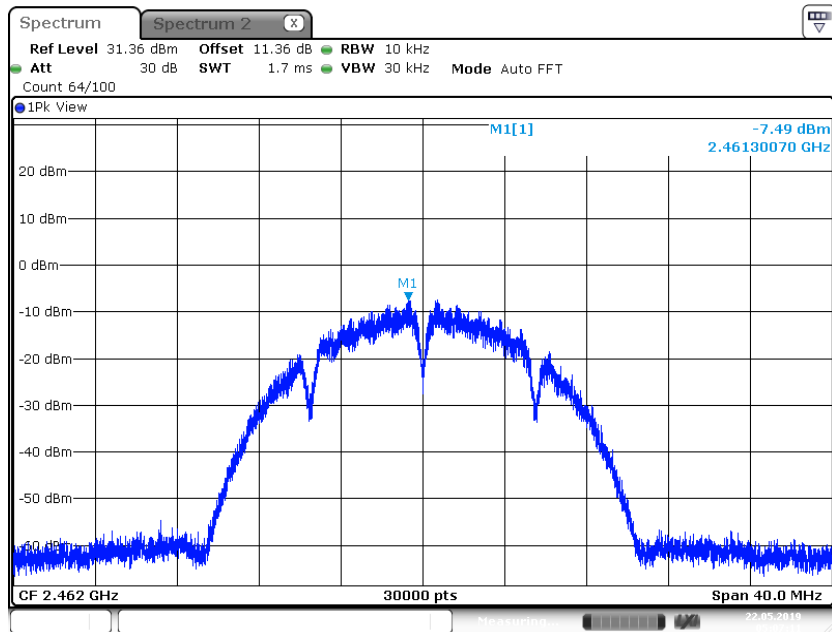

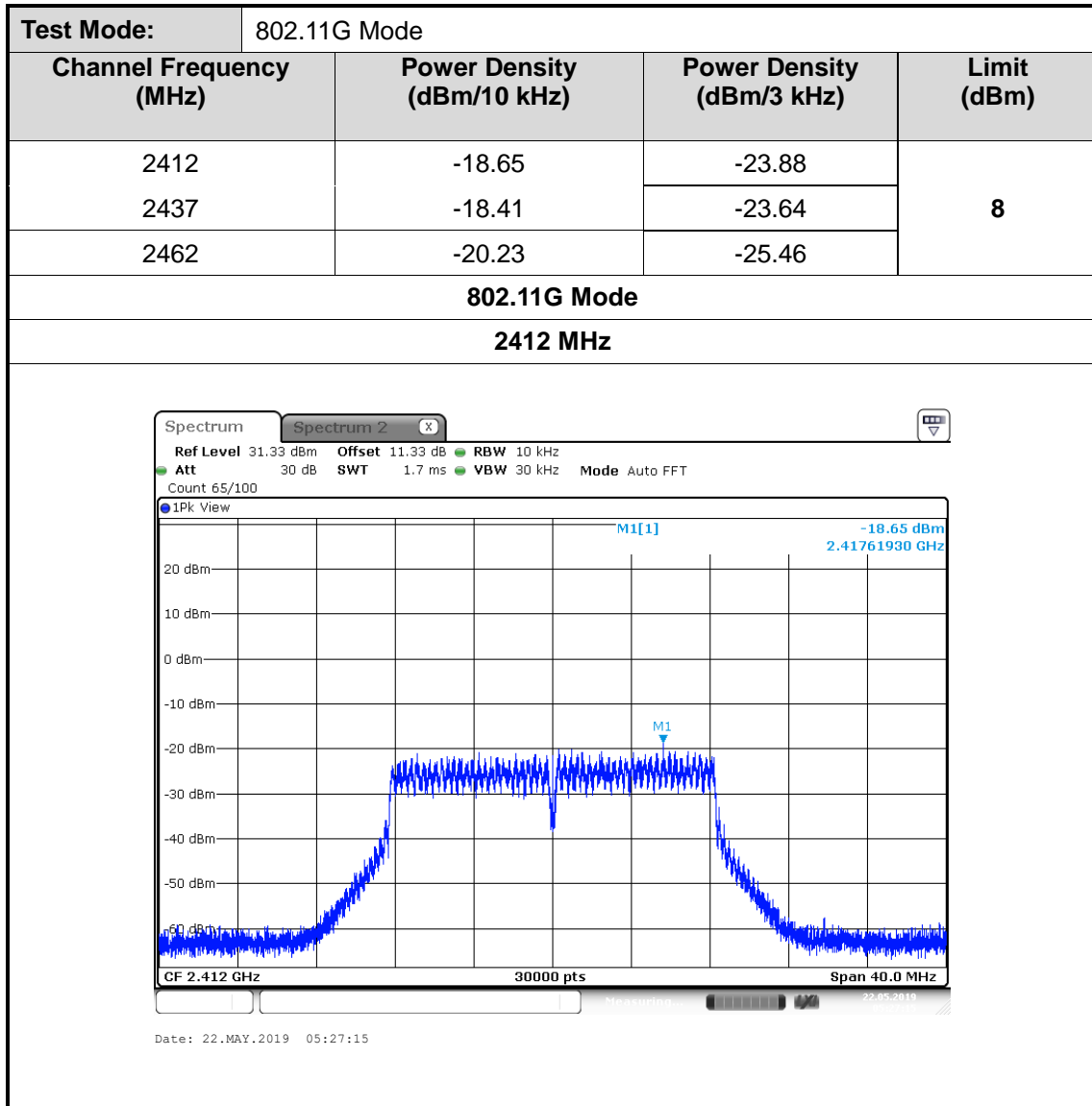

802.11G Mode

2437 MHz

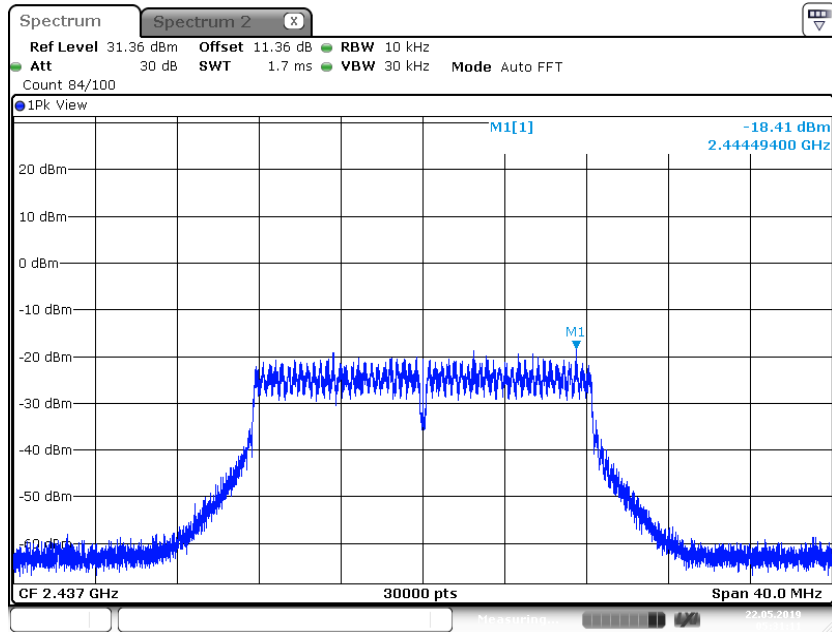

802.11G Mode

2462 MHz

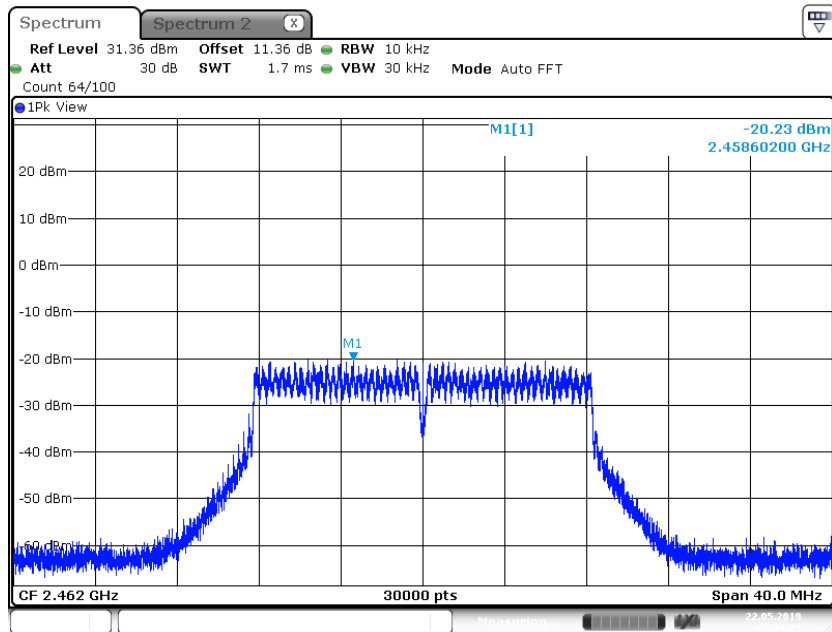

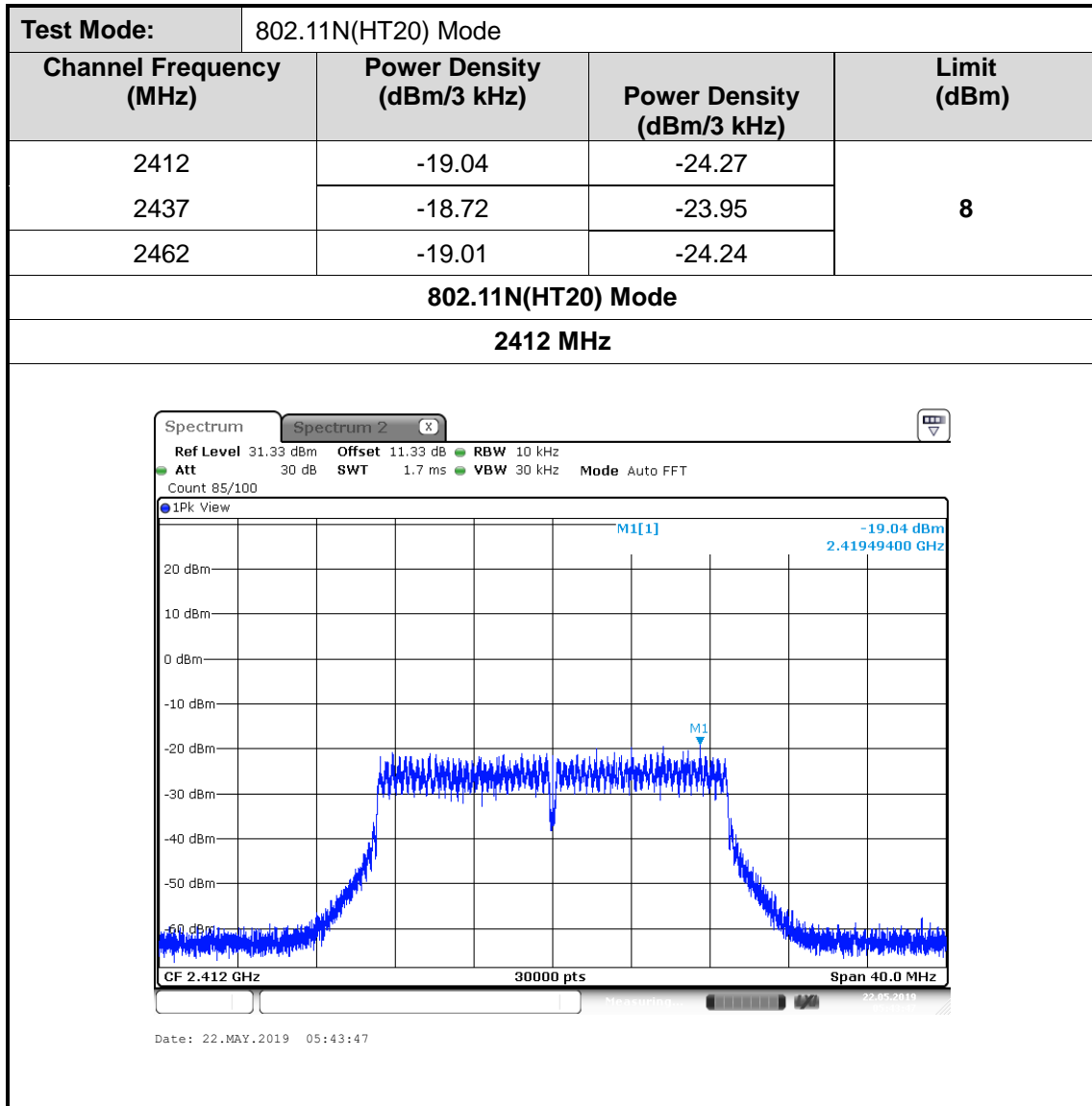

802.11N(HT20) Mode

2437 MHz

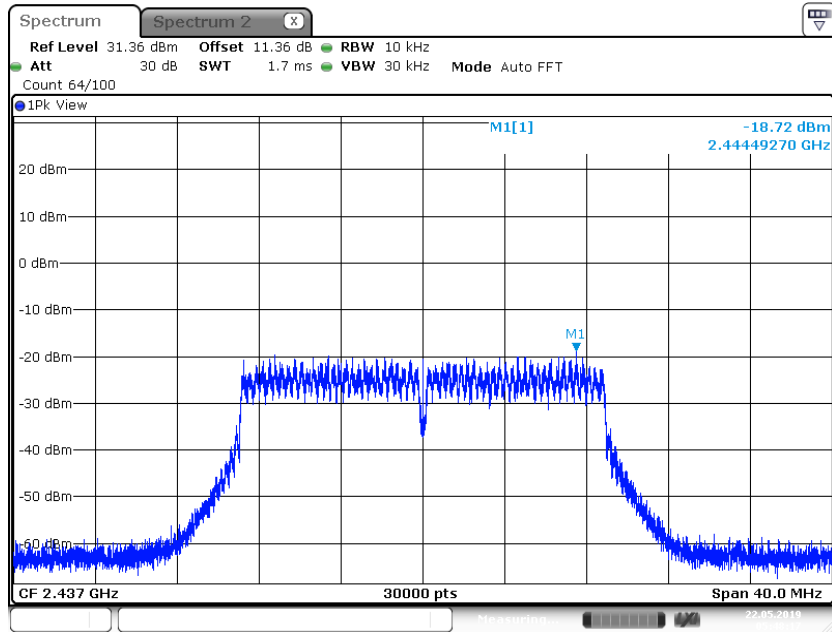

802.11N(HT20) Mode

2462 MHz

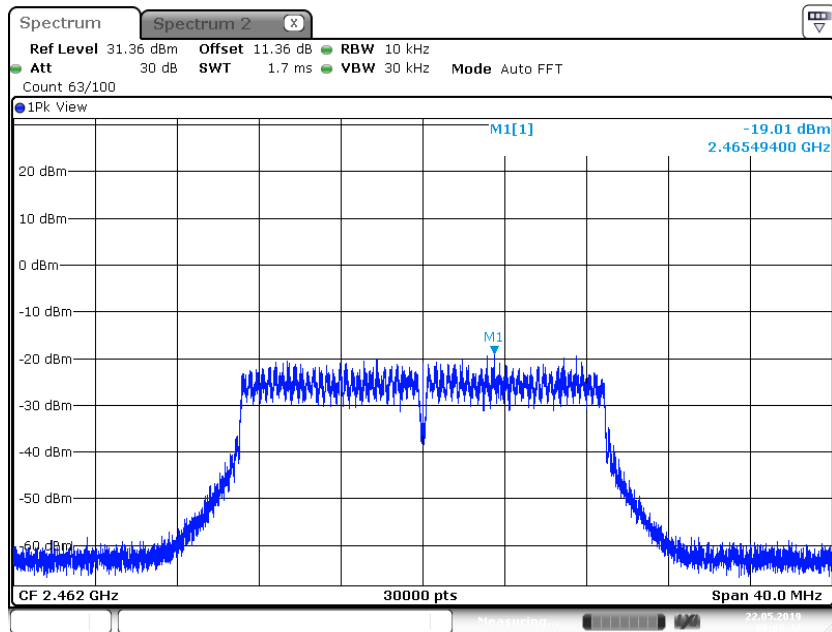

3.6. Band edge and Spurious Emission (conducted)

LIMIT

FCC CFR Title 47 Part 15 Subpart C Section 15.247 (d):

In any 100 kHz bandwidth outside the frequency band in which the spread spectrum intentional radiator is operating, the radio frequency power that is produced by the intentional radiator shall be at least 20 dB below that in the 100 kHz bandwidth within the band that contains the highest level of the desired power, based on either an RF conducted or a radiated measurement.

TEST CONFIGURATION

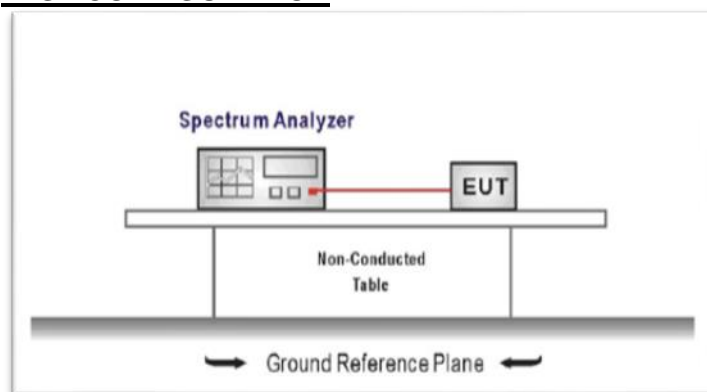

TEST PROCEDURE

1. Connect the antenna port(s) to the spectrum analyzer input.
2. Establish a reference level by using the following procedure
 - Center frequency=DTS channel center frequency
 - The span = 1.5 times the DTS bandwidth.
 - RBW = 100 kHz, VBW \geq 3 x RBW
 - Detector = peak, Sweep time = auto couple, Trace mode = max hold
 - Allow trace to fully stabilize
 - Use the peak marker function to determine the maximum PSD level

Note: the channel found to contain the maximum PSD level can be used to establish the reference level.
3. Emission level measurement
 - Set the center frequency and span to encompass frequency range to be measured
 - RBW = 100 kHz, VBW \geq 3 x RBW
 - Detector = peak, Sweep time = auto couple, Trace mode = max hold
 - Allow trace to fully stabilize
 - Use the peak marker function to determine the maximum amplitude level.
4. Place the radio in continuous transmit mode, allow the trace to stabilize, view the transmitter waveform on the spectrum analyzer.
5. Ensure that the amplitude of all unwanted emissions outside of the authorized frequency band excluding restricted frequency bands) are attenuated by at least the minimum requirements specified (at least 20 dB relative to the maximum in-band peak PSD level in 100 kHz). Report the three highest emissions relative to the limit.

TEST MODE:

Please refer to the clause 2.3.

TEST RESULTS

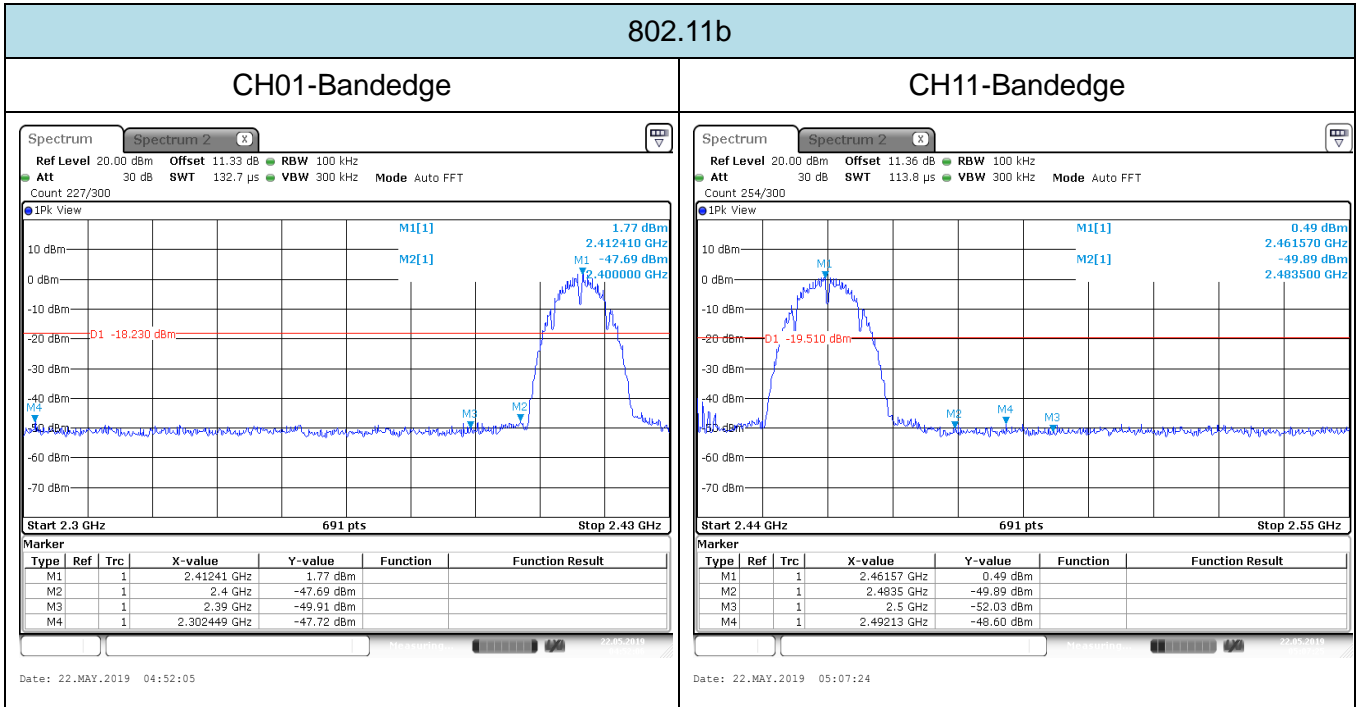

802.11b

CH01-SE

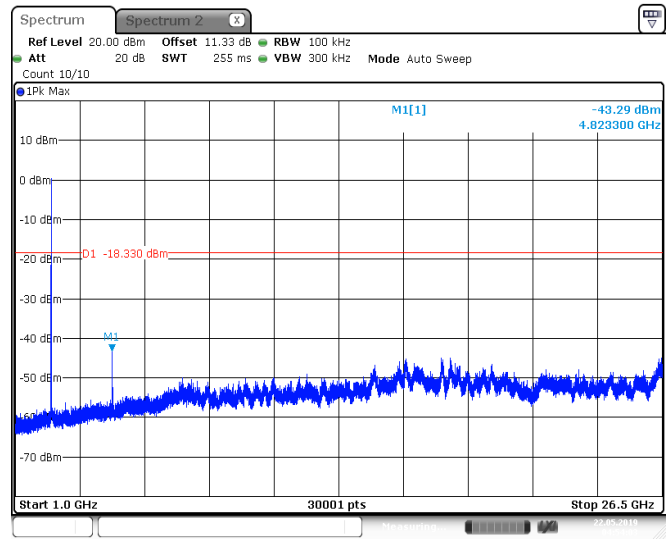
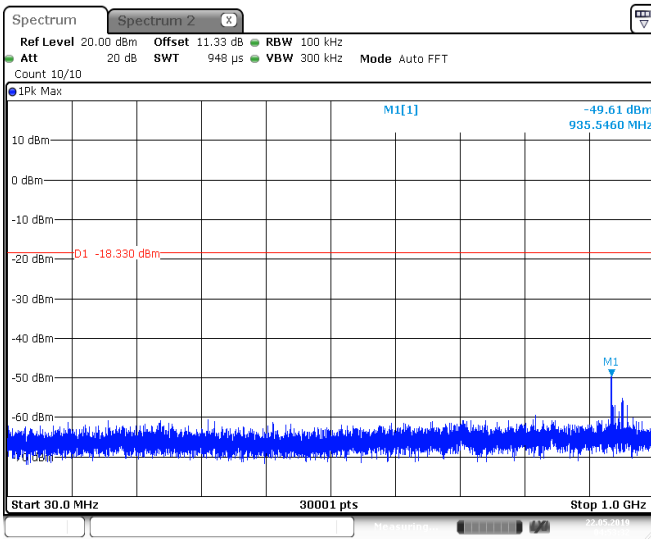

CH06-SE

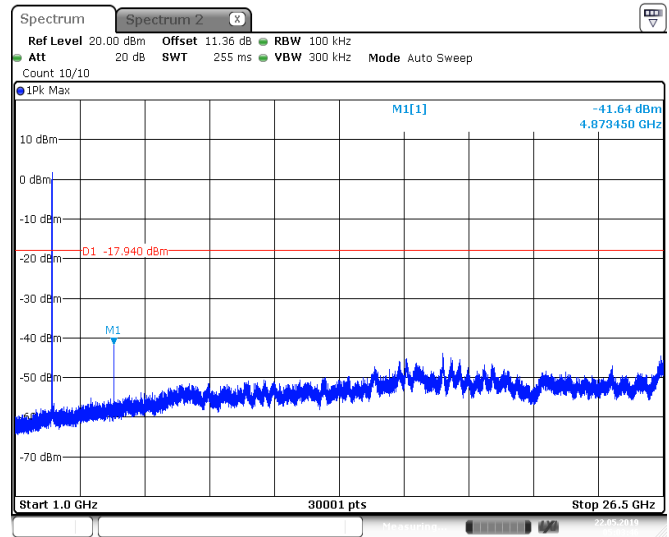
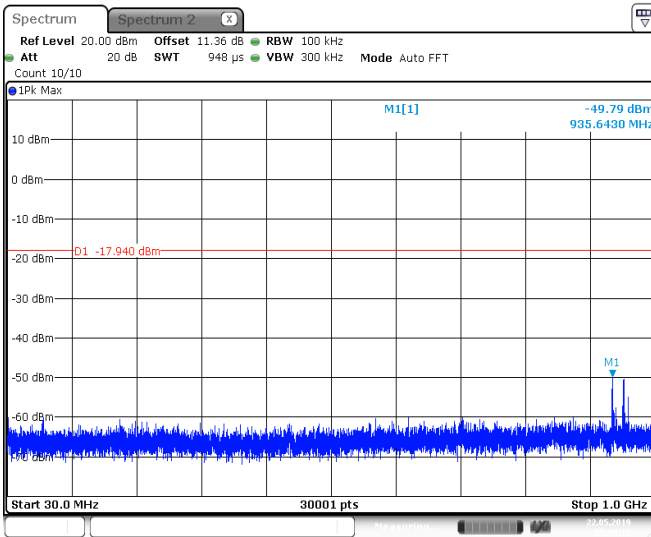

CH11-SE

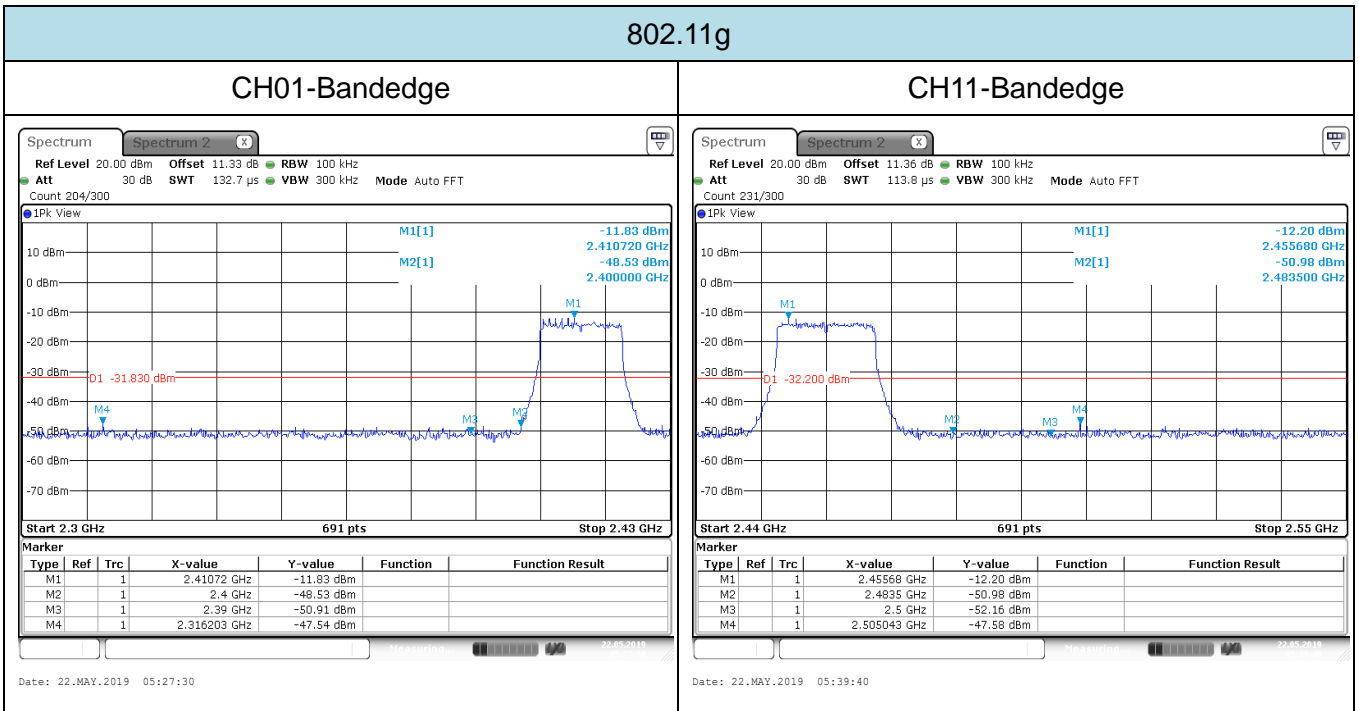
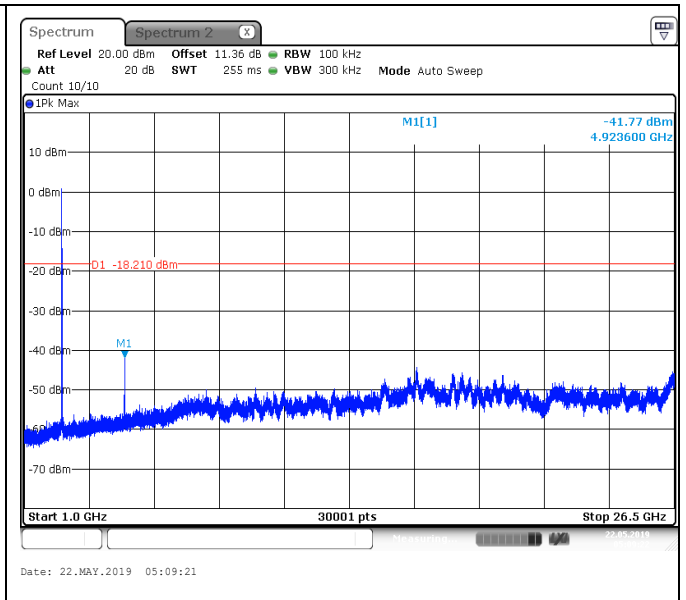
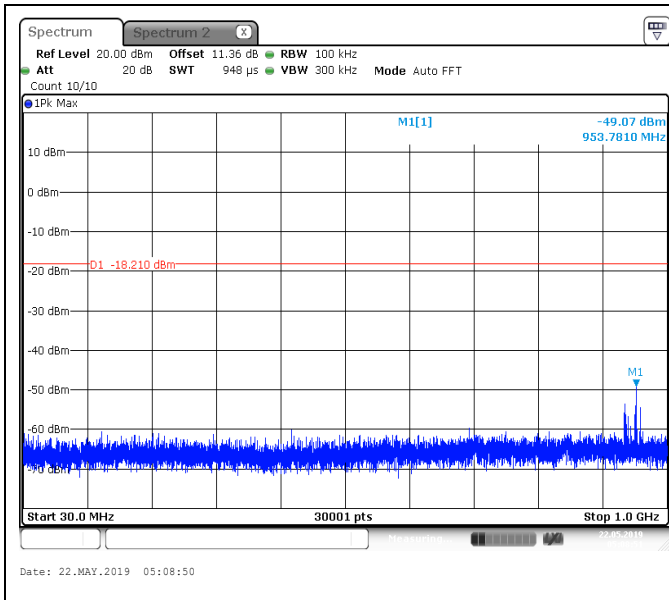

802.11g

CH01-SE

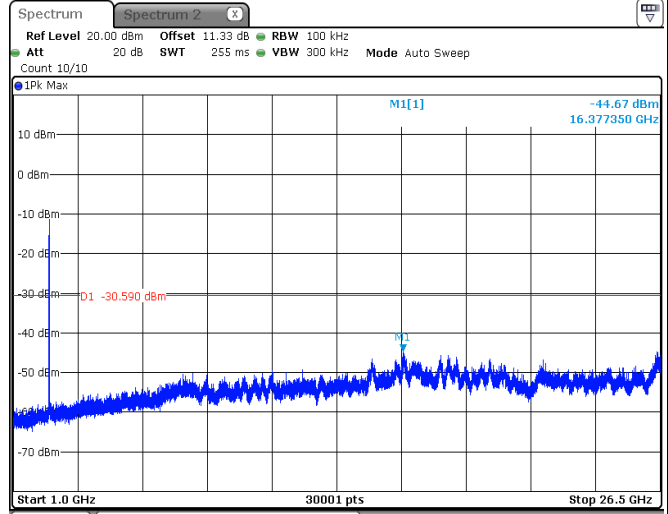
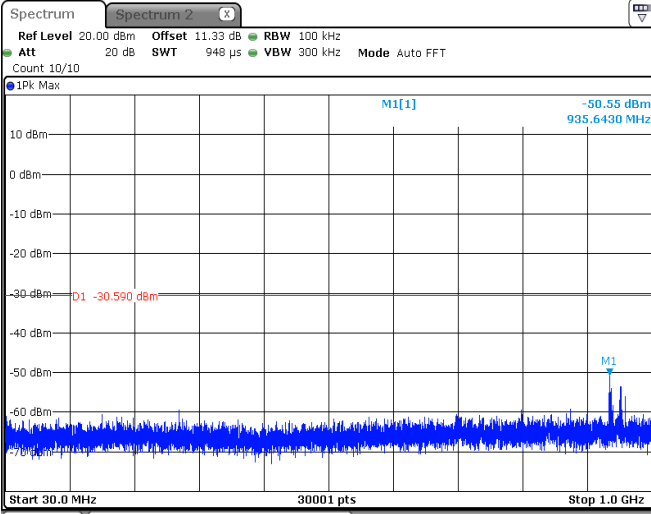

CH06-SE

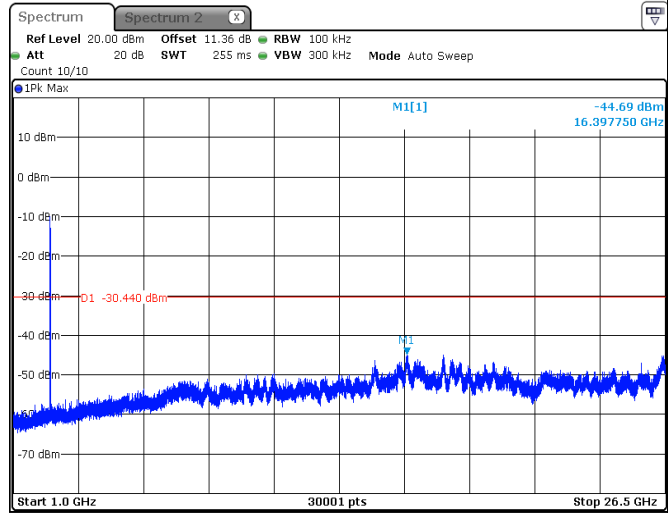
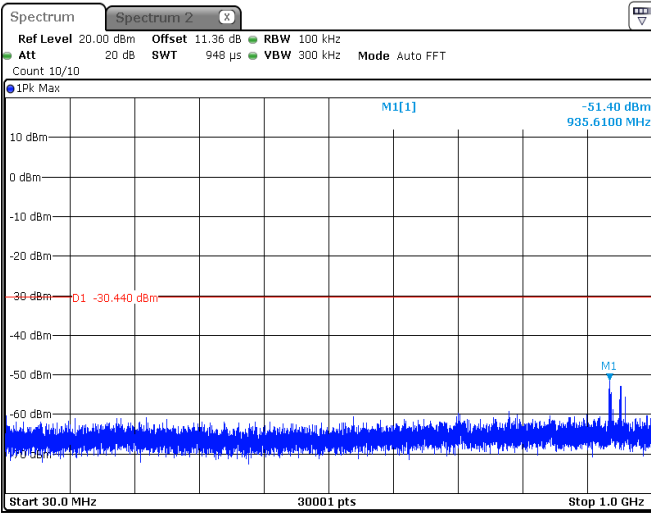

CH11-SE

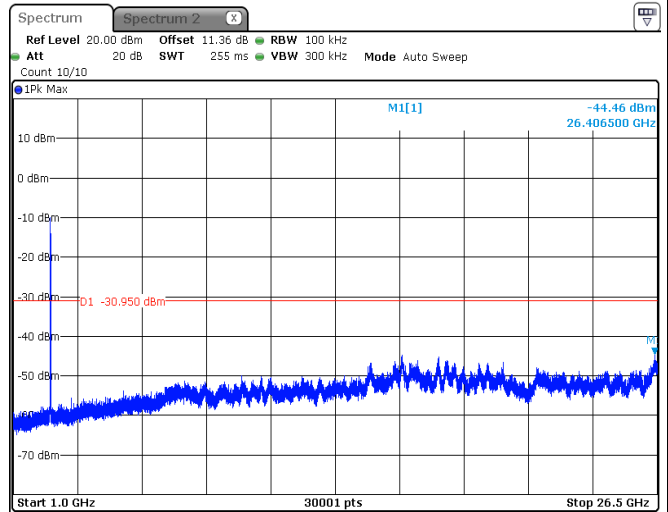
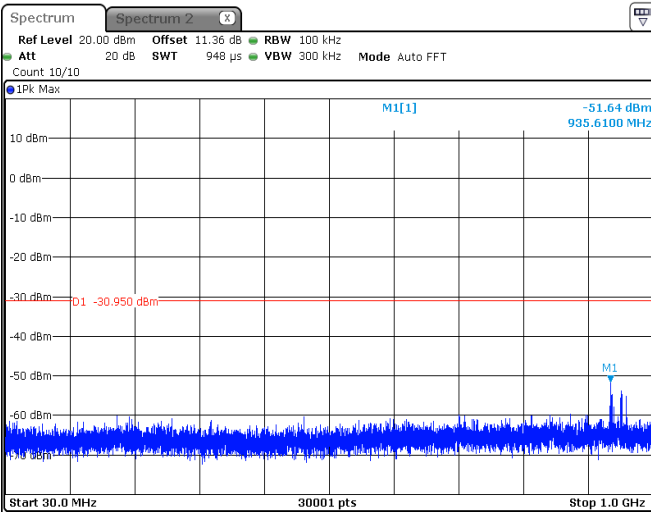

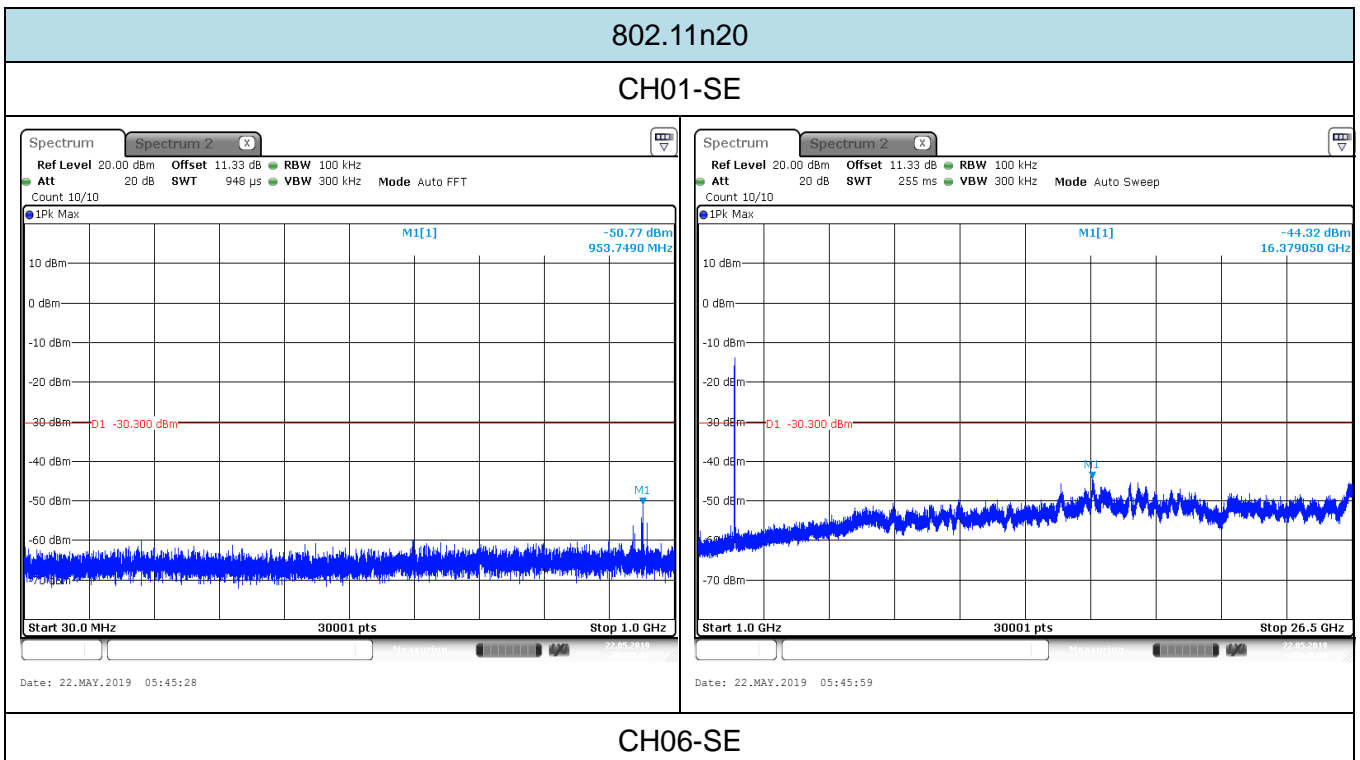
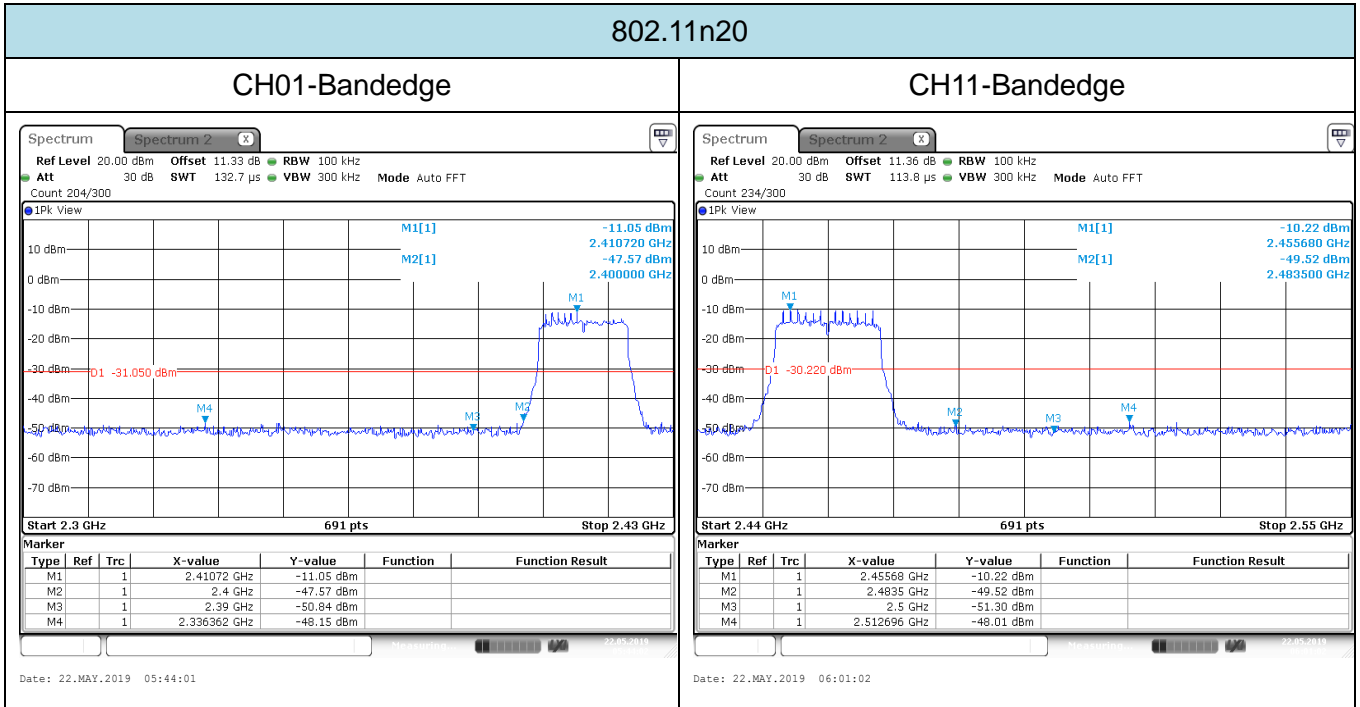

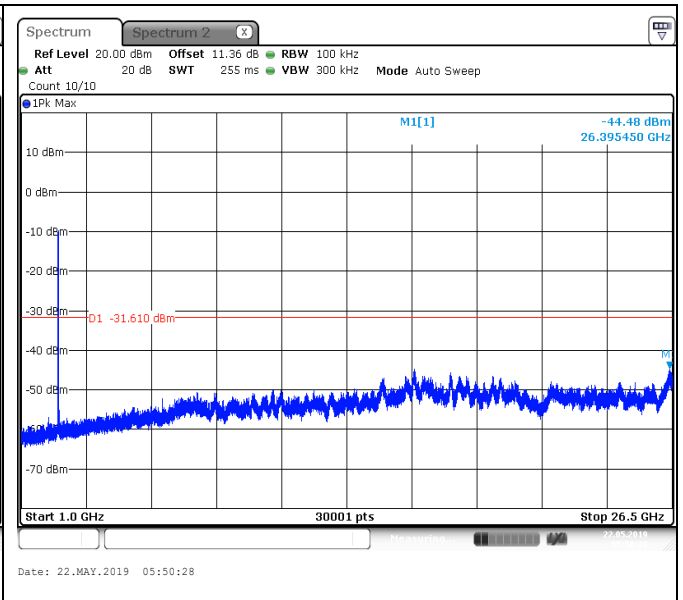
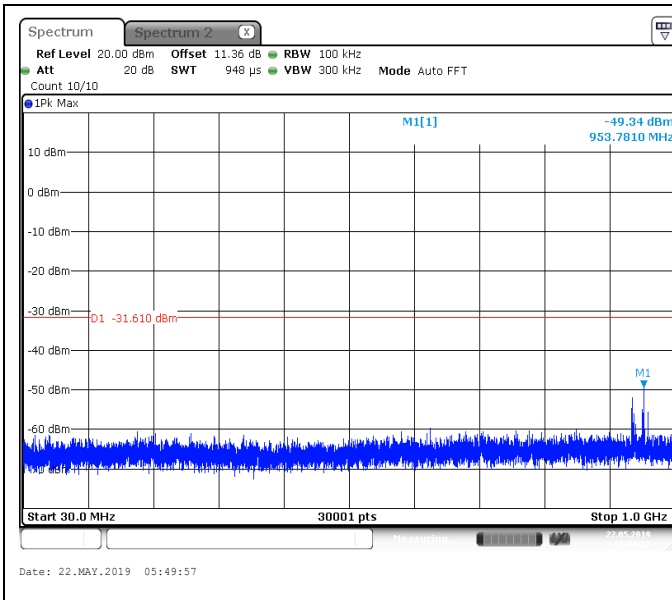

CH11-SE

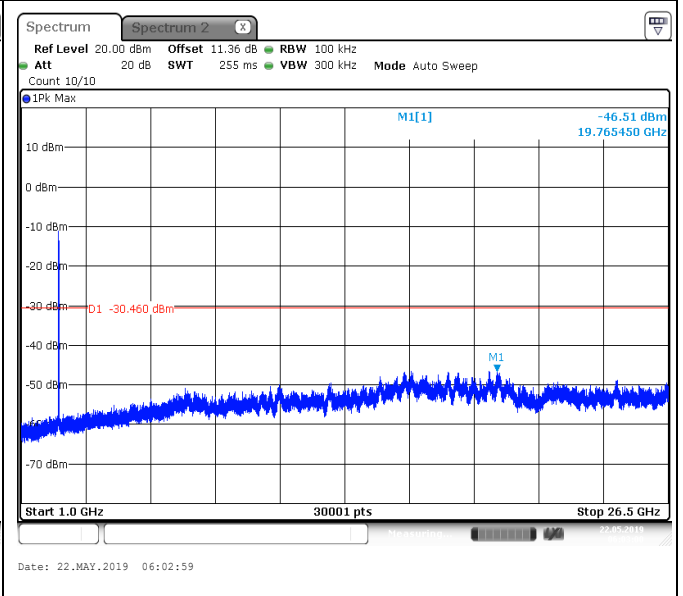
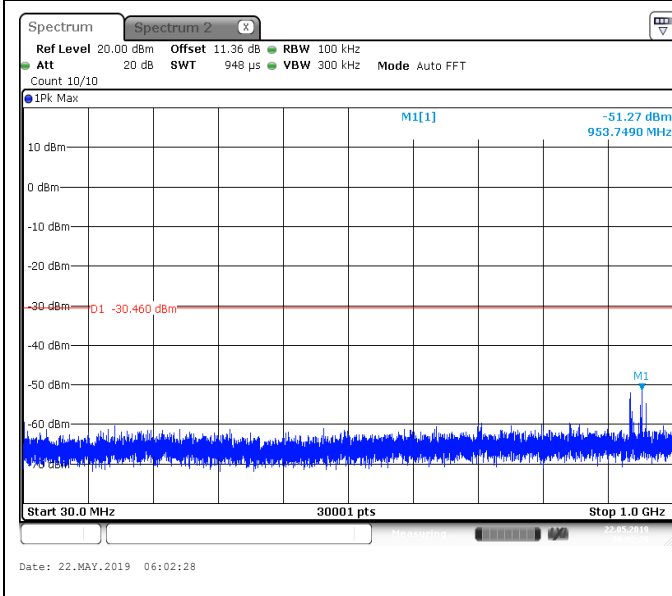

3.7. Band Edge Emissions

Limit

Restricted Frequency Band (MHz)	(dBuV/m)(at 3m)	
	Peak	Average
2310 ~2390	74	54
2483.5 ~2500	74	54

Note: All restriction bands have been tested, only the worst case is reported.

Test Configuration

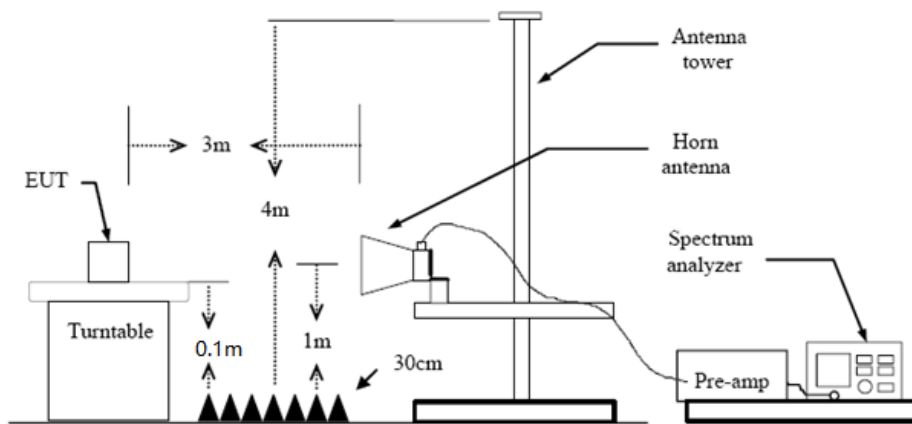

Test Procedure

1. The EUT was setup and tested according to ANSI C63.10:2013 requirements.
2. The EUT is placed on a turn table which is 0.1 meter above ground. The turn table is rotated 360 degrees to determine the position of the maximum emission level.
3. The EUT was positioned such that the distance from antenna to the EUT was 3 meters.
4. The antenna is scanned from 1 meter to 4 meters to find out the maximum emission level. This is repeated for both horizontal and vertical polarization of the antenna. In order to find the maximum emission, all of the interface cables were manipulated according to ANSI C63.10:2013 on radiated measurement.
5. The receiver set as follow:
 RBW=1MHz, VBW=3MHz PEAK detector for Peak value.
 RBW=1MHz, VBW=10Hz with PEAK Detector for Average Value.

Test Mode

Please refer to the clause 2.2.

Test Results

Passed **Not Applicable**

Note:

- 1) Final level= Read level + Antenna Factor + Cable Loss - Preamp Factor

802.11b					CH01				
Frequency (MHz)	Read Level (dBuV)	Antenna Factor (dB/m)	Cable Loss (dB)	Preamp Factor (dB)	Level (dBuV/m)	Limit Line (dBuV/m)	Margin (dB)	Polarization	Test value
2310	19.44	26.01	4.52	0	49.97	74	-24.03	Vertical	Peak
2390.01	20.32	26.84	4.89	0	52.05	74	-21.95	Vertical	
2310	14.39	26.01	4.52	0	44.92	54	-9.08	Vertical	Average
2390.01	15.86	26.84	4.89	0	47.59	54	-6.41	Vertical	
2310	18.26	26.11	4.52	0	48.89	74	-25.11	Horizontal	Peak
2390.01	18.97	26.75	4.89	0	50.61	74	-23.39	Horizontal	
2310	15.21	26.11	4.52	0	45.84	54	-8.16	Horizontal	Average
2390.01	15.79	26.75	4.89	0	47.43	54	-6.57	Horizontal	

802.11b					CH11				
Frequency (MHz)	Read Level (dBuV)	Antenna Factor (dB/m)	Cable Loss (dB)	Preamp Factor (dB)	Level (dBuV/m)	Limit Line (dBuV/m)	Margin (dB)	Polarization	Test value
2483.49	20.58	27.1	4.52	0	52.2	74	-22.89	Vertical	Peak
2500.00	20.62	27.6	4.89	0	53.11	74	-21.65	Vertical	
2483.49	15.36	27.1	4.52	0	46.98	54	-8.11	Vertical	Average
2500.00	15.64	27.6	4.89	0	48.13	54	-6.63	Vertical	
2483.49	19.81	26.33	4.52	0	50.66	74	-23.56	Horizontal	Peak
2500.00	19.78	27.6	4.89	0	52.27	74	-22.58	Horizontal	
2483.49	15.49	26.33	4.52	0	46.34	54	-7.88	Horizontal	Average
2500.00	15.86	27.6	4.89	0	48.35	54	-6.5	Horizontal	

802.11g					CH01				
Frequency (MHz)	Read Level (dBuV)	Antenna Factor (dB/m)	Cable Loss (dB)	Preamp Factor (dB)	Level (dBuV/m)	Limit Line (dBuV/m)	Margin (dB)	Polarization	Test value
2310.00	20.26	27.1	4.52	0	51.88	74	20.26	Vertical	Peak
2390.01	20.89	27.6	4.89	0	53.38	74	20.89	Vertical	
2310.00	15.44	27.1	4.52	0	47.06	54	15.44	Vertical	Average
2390.01	15.37	27.6	4.89	0	47.86	54	15.37	Vertical	
2310.00	19.73	26.33	4.52	0	50.58	74	19.73	Horizontal	Peak
2390.01	19.52	27.6	4.89	0	52.01	74	19.52	Horizontal	
2310.00	15.29	26.33	4.52	0	46.14	54	15.29	Horizontal	Average
2390.01	15.77	27.6	4.89	0	48.26	54	15.77	Horizontal	

802.11g					CH11				
Frequency (MHz)	Read Level (dBuV)	Antenna Factor (dB/m)	Cable Loss (dB)	Preamp Factor (dB)	Level (dBuV/m)	Limit Line (dBuV/m)	Margin (dB)	Polarization	Test value
2483.49	20.47	27.1	4.52	0	52.09	74	-21.91	Vertical	Peak
2500.00	20.85	27.6	4.89	0	53.34	74	-20.66	Vertical	
2483.49	15.78	27.1	4.52	0	47.4	54	-6.6	Vertical	Average
2500.00	15.83	27.6	4.89	0	48.32	54	-5.68	Vertical	
2483.49	19.45	26.33	4.52	0	50.3	74	-23.7	Horizontal	Peak
2500.00	19.77	27.6	4.89	0	52.26	74	-21.74	Horizontal	
2483.49	15.63	26.33	4.52	0	46.48	54	-7.52	Horizontal	Average
2500.00	15.82	27.6	4.89	0	48.31	54	-5.69	Horizontal	

802.11n(H20)					CH01				
Frequency (MHz)	Read Level (dBuV)	Antenna Factor (dB/m)	Cable Loss (dB)	Preamp Factor (dB)	Level (dBuV/m)	Limit Line (dBuV/m)	Margin (dB)	Polarization	Test value
2310.00	18.64	27.1	4.52	0	50.26	74	18.64	Vertical	Peak
2390.01	19.52	27.6	4.89	0	52.01	74	19.52	Vertical	
2310.00	15.46	27.1	4.52	0	47.08	54	15.46	Vertical	Average
2390.01	16.22	27.6	4.89	0	48.71	54	16.22	Vertical	
2310.00	19.68	26.33	4.52	0	50.53	74	19.68	Horizontal	Peak
2390.01	20.33	27.6	4.89	0	52.82	74	20.33	Horizontal	
2310.00	15.49	26.33	4.52	0	46.34	54	15.49	Horizontal	Average
2390.01	15.89	27.6	4.89	0	48.38	54	15.89	Horizontal	

802.11n(H20)					CH11				
Frequency (MHz)	Read Level (dBuV)	Antenna Factor (dB/m)	Cable Loss (dB)	Preamp Factor (dB)	Level (dBuV/m)	Limit Line (dBuV/m)	Margin (dB)	Polarization	Test value
2483.49	19.85	27.1	4.52	0	51.47	74.00	-22.53	Vertical	Peak
2500.00	19.25	27.6	4.89	0	51.74	74.00	-22.26	Vertical	
2483.49	15.49	27.1	4.52	0	47.11	54.00	-6.89	Vertical	Average
2500.00	15.91	27.6	4.89	0	48.4	54.00	-5.6	Vertical	
2483.49	19.44	26.33	4.52	0	50.29	74.00	-23.71	Horizontal	Peak
2500.00	20.91	27.6	4.89	0	53.4	74.00	-20.6	Horizontal	
2483.49	15.43	26.33	4.52	0	46.28	54.00	-7.72	Horizontal	Average
2500.00	15.39	27.6	4.89	0	47.88	54.00	-6.12	Horizontal	

3.8. Spurious Emission (radiated)

Limit

Radiated Emission Limits (9 kHz~1000 MHz)

Frequency (MHz)	Field Strength (microvolt/meter)	Measurement Distance (meters)
0.009~0.490	2400/F(KHz)	300
0.490~1.705	24000/F(KHz)	30
1.705~30.0	30	30
30~88	100	3
88~216	150	3
216~960	200	3
Above 960	500	3

Radiated Emission Limit (Above 1000MHz)

Frequency (MHz)	Distance Meters(at 3m)	
	Peak	Average
Above 1000	74	54

Note:

- (1) The tighter limit applies at the band edges.
- (2) Emission Level (dBuV/m)=20log Emission Level (uV/m).

Test Configuration

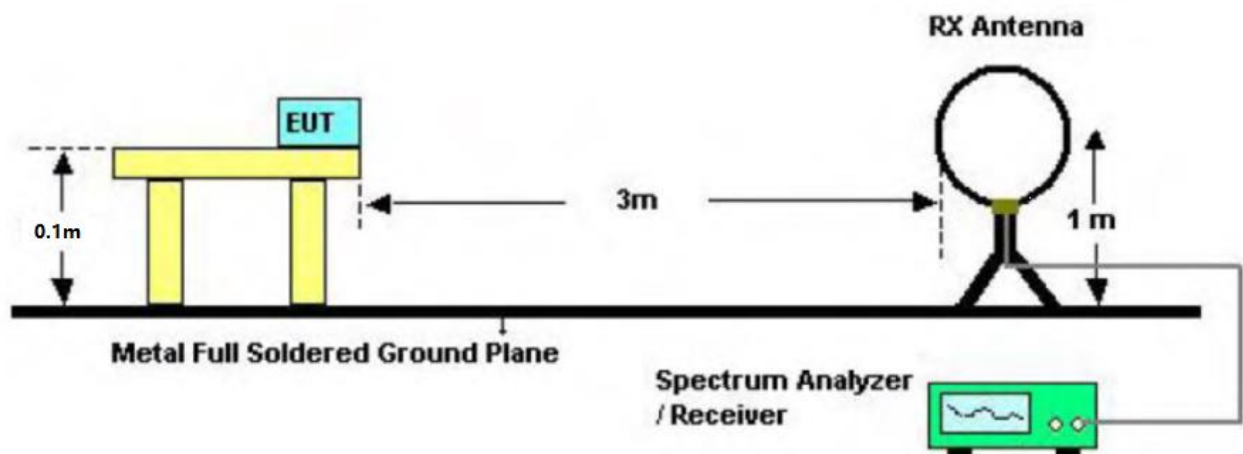

Below 30MHz Test Setup

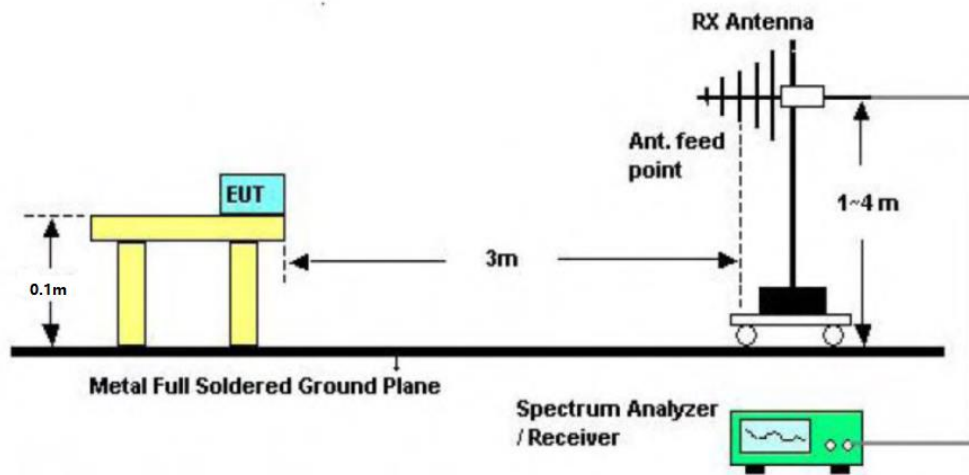

Below 1000MHz Test Setup

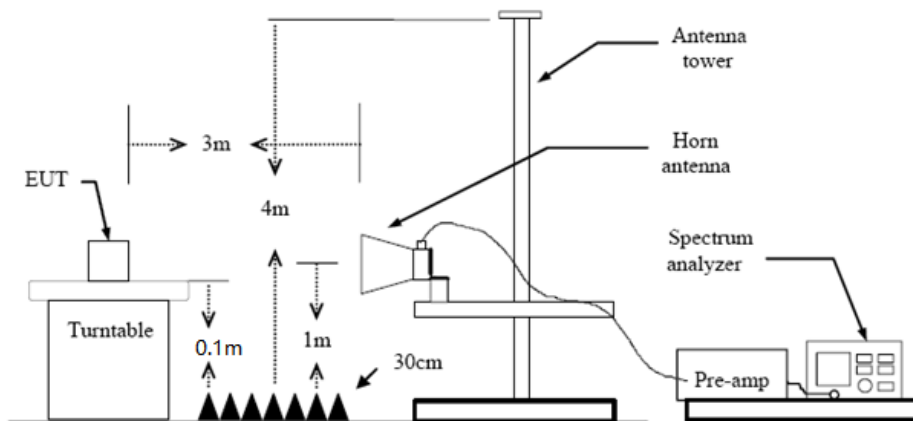

Above 1GHz Test Setup

Test Procedure

1. The EUT was setup and tested according to ANSI C63.10:2013
2. The EUT is placed on a turn table which is 0.1 meter above ground for below 1 GHz, and 0.1m for above 1 GHz. The turn table is rotated 360 degrees to determine the position of the maximum emission level.
3. The EUT was set 3 meters from the receiving antenna, which was mounted on the top of a variable height antenna tower.
4. For each suspected emission, the EUT was arranged to its worst case and then tune the Antenna tower (from 1 m to 4 m) and turntable (from 0 degree to 360 degrees) to find the maximum reading. A pre-amp and a high pass filter are used for the test in order to get better signal level to comply with the guidelines.
5. Set to the maximum power setting and enable the EUT transmit continuously.
6. Use the following spectrum analyzer settings
 - (1) Span shall wide enough to fully capture the emission being measured;
 - (2) Below 1 GHz:
RBW=120 kHz, VBW=300 kHz, Sweep=auto, Detector function=peak, Trace=max hold;
If the emission level of the EUT measured by the peak detector is 3 dB lower than the applicable limit, the peak emission level will be reported. Otherwise, the emission measurement will be repeated using the quasi-peak detector and reported.
 - (3) From 1 GHz to 10th harmonic:
RBW=1MHz, VBW=3MHz Peak detector for Peak value.
RBW=1MHz, VBW=3MHz RMS detector for Average value.

Test Mode

Please refer to the clause 2.2.

Test Result

9 KHz~30 MHz and 18GHz~25GHz

From 9 KHz~30 MHz and 18GHz~25GHz: Conclusion: PASS

Note: The amplitude of spurious emissions which are attenuated by more than 20dB below the permissible value has no need to be reported.

Note:

- 1) Final Level =Receiver Read level + Antenna Factor + Cable Loss – Preamplifier Factor
- 2) The emission levels of other frequencies are very lower than the limit and not show in test report.

30MHz-1GHz

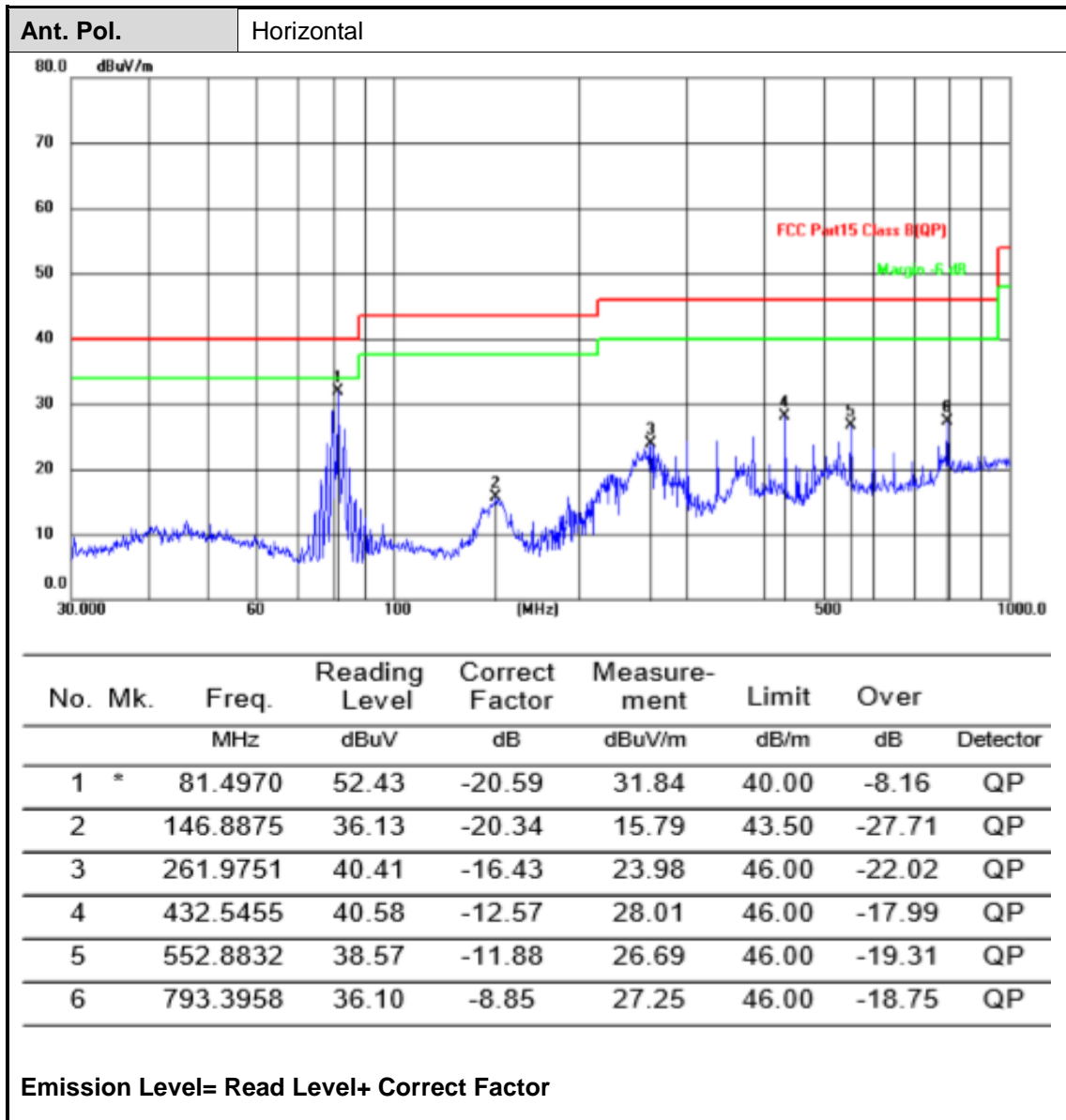

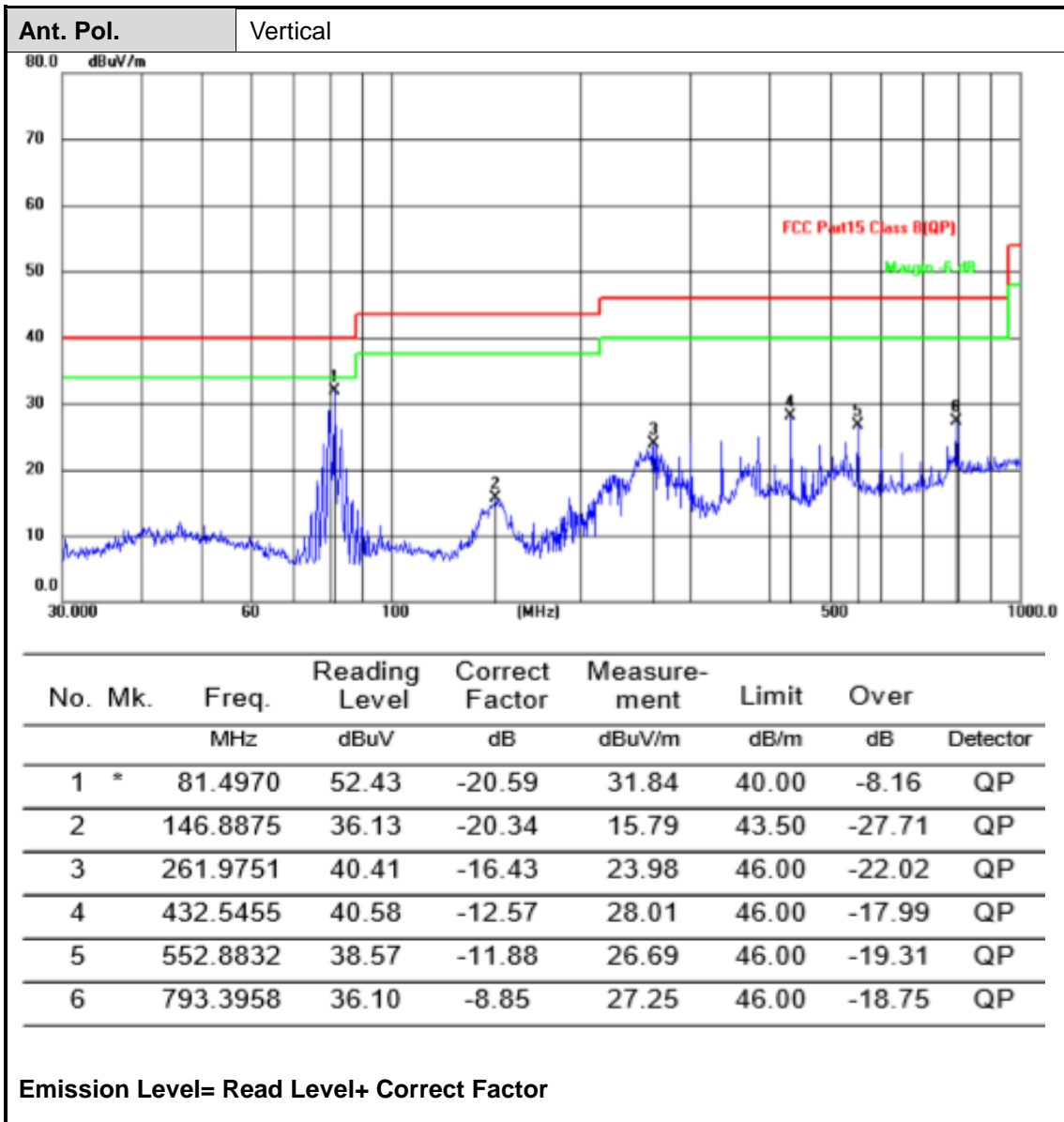

Adobe 1GHz

802.11b					CH01				
Frequency (MHz)	Read Level (dBuV)	Antenna Factor (dB/m)	Cable Loss (dB)	Preamp Factor (dB)	Level (dBuV/m)	Limit Line (dBuV/m)	Margin (dB)	Polarization	Test value
1591.29	44.56	24.99	3.36	26.38	46.53	74	-27.47	Vertical	Peak
2132.74	43.22	26.94	3.74	37.33	36.57	74	-37.43	Vertical	
4823.30	55.47	31.74	6.27	36.26	57.22	74	-16.78	Vertical	
6733.25	35.74	34.14	6.5	35.12	41.26	74	-32.74	Vertical	
1751.29	38.12	25.3	3.39	37.04	29.77	74	-44.23	Horizontal	
2125.32	41.91	26.94	3.68	37.33	35.2	74	-38.8	Horizontal	
4823.30	54.42	31.74	6.27	36.26	56.17	74	-17.83	Horizontal	
6629.39	32.35	34.2	6.74	35.31	37.98	74	-36.02	Horizontal	
4823.30	43.14	31.74	6.27	36.26	44.89	54	-9.11	Vertical	Average
4823.30	41.41	31.74	6.27	36.26	43.16	54	-10.84	Horizontal	

802.11b					CH06				
Frequency (MHz)	Read Level (dBuV)	Antenna Factor (dB/m)	Cable Loss (dB)	Preamp Factor (dB)	Level (dBuV/m)	Limit Line (dBuV/m)	Margin (dB)	Polarization	Test value
1442.76	39.25	24.99	3.36	26.38	41.22	74	-32.78	Vertical	Peak
2129.79	39.45	26.94	3.74	37.33	32.8	74	-41.2	Vertical	
4874.30	55.07	31.74	6.27	36.26	56.82	74	-17.18	Vertical	
7585.53	31.46	34.14	6.5	35.12	36.98	74	-37.02	Vertical	
1750.7	40.58	25.3	3.39	37.04	32.23	74	-41.77	Horizontal	
2129.79	39.47	26.94	3.68	37.33	32.76	74	-41.24	Horizontal	
3579.82	37.59	31.44	5.8	37.01	37.82	74	-36.18	Horizontal	
4874.30	52.16	31.74	6.27	36.26	53.91	74	-20.09	Horizontal	
4874.30	41.04	31.74	6.27	36.26	42.79	54	-11.21	Vertical	Average

802.11b					CH11				
Frequency (MHz)	Read Level (dBuV)	Antenna Factor (dB/m)	Cable Loss (dB)	Preamp Factor (dB)	Level (dBuV/m)	Limit Line (dBuV/m)	Margin (dB)	Polarization	Test value
1208.37	36.38	24.99	3.36	26.38	38.35	74	-35.65	Vertical	Peak
2125.62	37.25	26.94	3.74	37.33	30.6	74	-43.4	Vertical	
4923.60	54.01	31.74	6.27	36.26	55.76	74	-18.24	Vertical	
7612.33	31.97	34.14	6.5	35.12	37.49	74	-36.51	Vertical	
1259.64	41.28	25.3	3.39	37.04	32.93	74	-41.07	Horizontal	
1706.39	39.64	26.94	3.68	37.33	32.93	74	-41.07	Horizontal	
3217.97	37.61	31.44	5.8	37.01	37.84	74	-36.16	Horizontal	

4923.60	50.25	31.74	6.27	36.26	52	74	-22	Horizontal	
4923.60	40.91	31.74	6.27	36.26	42.66	54	-11.34	Vertical	Average

802.11g					CH01				
Frequency (MHz)	Read Level (dBuV)	Antenna Factor (dB/m)	Cable Loss (dB)	Preamp Factor (dB)	Level (dBuV/m)	Limit Line (dBuV/m)	Margin (dB)	Polarization	Test value
1586.23	41.66	24.99	3.36	26.38	43.63	74	-30.37	Vertical	Peak
2133.65	40.78	26.94	3.74	37.33	34.13	74	-39.87	Vertical	
4819.90	43.64	31.74	6.27	36.26	45.39	74	-28.61	Vertical	
5631.97	35.44	34.14	6.5	35.12	40.96	74	-33.04	Vertical	
1597.48	43.29	25.3	3.39	37.04	34.94	74	-39.06	Horizontal	
2129.55	44.68	26.94	3.68	37.33	37.97	74	-36.03	Horizontal	
4826.7	42.22	31.74	6.27	36.26	42.45	74	-31.55	Horizontal	
6697.21	34.73	34.2	6.74	35.31	40.36	74	-33.64	Horizontal	

802.11g					CH06				
Frequency (MHz)	Read Level (dBuV)	Antenna Factor (dB/m)	Cable Loss (dB)	Preamp Factor (dB)	Level (dBuV/m)	Limit Line (dBuV/m)	Margin (dB)	Polarization	Test value
1644.57	38.25	24.99	3.36	26.38	40.22	74	-33.78	Vertical	Peak
2133.32	41.68	26.94	3.74	37.33	35.03	74	-38.97	Vertical	
4876.23	49.40	31.74	6.27	36.26	51.15	74	-22.85	Vertical	
5525.96	34.21	34.14	6.5	35.12	39.73	74	-34.27	Vertical	
1598.50	43.33	25.3	3.39	37.04	34.98	74	-39.02	Horizontal	
2119.88	44.44	26.94	3.68	37.33	37.73	74	-36.27	Horizontal	
4876.21	43.68	31.74	6.27	36.26	43.91	74	-30.09	Horizontal	
5117.33	35.74	34.2	6.74	35.31	41.37	74	-32.63	Horizontal	

802.11g					CH11				
Frequency (MHz)	Read Level (dBuV)	Antenna Factor (dB/m)	Cable Loss (dB)	Preamp Factor (dB)	Level (dBuV/m)	Limit Line (dBuV/m)	Margin (dB)	Polarization	Test value
1587.63	42.58	24.99	3.36	26.38	44.55	74	-29.45	Vertical	Peak
3185.67	36.76	26.94	3.74	37.33	30.11	74	-43.89	Vertical	
4927	44.06	31.74	6.27	36.26	45.81	74	-28.19	Vertical	
6595.71	35.31	34.14	6.5	35.12	40.83	74	-33.17	Vertical	
1588.23	44.34	25.3	3.39	37.04	35.99	74	-38.01	Horizontal	
1684.5	43.13	26.94	3.68	37.33	36.42	74	-37.58	Horizontal	
2117.89	45.21	31.44	5.8	37.01	45.44	74	-28.56	Horizontal	
4927	40.7	31.74	6.27	36.26	42.45	74	-31.55	Horizontal	

802.11n(H20)					CH01				
Frequency (MHz)	Read Level (dBuV)	Antenna Factor (dB/m)	Cable Loss (dB)	Preamp Factor (dB)	Level (dBuV/m)	Limit Line (dBuV/m)	Margin (dB)	Polarization	Test value
1665.44	37.45	24.99	3.36	26.38	39.42	74	-34.58	Vertical	Peak
2140.62	36.73	26.94	3.74	37.33	30.08	74	-43.92	Vertical	
4825	44.12	31.74	6.27	36.26	45.87	74	-28.13	Vertical	
6956.41	33.26	34.14	6.5	35.12	38.78	74	-35.23	Vertical	
1706.42	38.62	25.3	3.39	37.04	30.27	74	-43.73	Horizontal	
3184.9	39.93	26.94	3.68	37.33	32.62	74	-41.38	Horizontal	
4825	42.53	31.74	6.27	36.26	44.28	74	-31.24	Horizontal	
6998.55	34.64	34.2	6.74	35.31	40.27	74	-33.78	Horizontal	

802.11n(H20)					CH06				
Frequency (MHz)	Read Level (dBuV)	Antenna Factor (dB/m)	Cable Loss (dB)	Preamp Factor (dB)	Level (dBuV/m)	Limit Line (dBuV/m)	Margin (dB)	Polarization	Test value
1777.89	38.78	24.99	3.36	26.38	40.75	74	-33.25	Vertical	Peak
2229.38	38.96	26.94	3.74	37.33	32.31	74	-41.69	Vertical	
4876	44.29	31.74	6.27	36.26	46.04	74	-27.96	Vertical	
7233.64	34.71	34.14	6.5	35.12	40.23	74	-33.77	Vertical	
1758.14	36.51	25.3	3.39	37.04	28.16	74	-45.84	Horizontal	
3153.47	36.25	26.94	3.68	37.33	29.54	74	-44.46	Horizontal	
4876	44.29	31.74	6.27	36.26	46.04	74	-27.96	Horizontal	
6993.64	33.77	34.2	6.74	35.31	39.4	74	-34.6	Horizontal	

802.11n(H20)					CH11				
Frequency (MHz)	Read Level (dBuV)	Antenna Factor (dB/m)	Cable Loss (dB)	Preamp Factor (dB)	Level (dBuV/m)	Limit Line (dBuV/m)	Margin (dB)	Polarization	Test value
2199.33	37.55	24.99	3.36	26.38	39.52	74	-34.48	Vertical	Peak
3185.64	38.64	26.94	3.74	37.33	31.99	74	-42.01	Vertical	
4927	44.79	31.74	6.27	36.26	46.54	74	-27.46	Vertical	
6816.79	34.33	34.14	6.5	35.12	39.85	74	-34.15	Vertical	
1238.66	37.22	25.3	3.39	37.04	37.04	74	-45.13	Horizontal	
1663.84	38.43	26.94	3.68	37.33	37.33	74	-42.28	Horizontal	
4927	45.14	31.74	6.27	36.26	37.01	74	-28.63	Horizontal	
6995.11	34.94	34.2	6.74	35.31	35.31	74	-33.53	Horizontal	

Remark:

1. Final Level = Receiver Read level + Antenna Factor + Cable Loss - Preamplifier Factor
2. The peak level is lower than average limit(54 dBuV/m), this data is the too weak instrument of signal is unable to test.
3. The emission levels of other frequencies are very lower than the limit and not show in test report.

4.EUT TEST PHOTOS

Reference to the document No.: Test Photos

5.PHOTOGRAPHS OF EUT CONSTRUCTIONAL

Reference to the document No.: External Photos and Internal Photos.

*****THE END*****