



MET Laboratories, Inc. *Safety Certification - EMI - Telecom Environmental Simulation*

914 WEST PATAPSCO AVENUE • BALTIMORE, MARYLAND 21230-3432 • PHONE (410) 354-3300 • FAX (410) 354-3313

33439 WESTERN AVENUE • UNION CITY, CALIFORNIA 94587 • PHONE (510) 489-6300 • FAX (510) 489-6372

3162 BELICK STREET • SANTA CLARA, CALIFORNIA 95054 • PHONE (408) 748-3585 • FAX (510) 489-6372

January 13, 2010

Firetide, Inc.
16795 Lark Ave. Suite 200
Los Gatos, CA 95032

Dear Paul Richards,

Enclosed is the EMC Wireless test report for compliance testing of the Firetide, Inc., 7200 Outdoor Unit as tested to the requirements of Title 47 of the CFR, Ch. 1 (10-1-06 ed.), Title 47 of the CFR, Part 15, Subpart B, Industry Canada ICES-003 Issue 4 February 2004 for Unintentional Radiators and Part 15.407, Industry Canada RSS-210, Issue 7, June 2007 for Intentional Radiators.

Thank you for using the services of MET Laboratories, Inc. If you have any questions regarding these results or if MET can be of further service to you, please feel free to contact me.

Sincerely yours,
MET LABORATORIES, INC.

Jennifer Warnell
Documentation Department

Reference: (\\Firetide, Inc.\\EMCS81748C-FCC407 Rev. 1)

Certificates and reports shall not be reproduced except in full, without the written permission of MET Laboratories, Inc.



MET Laboratories, Inc. *Safety Certification - EMI - Telecom Environmental Simulation*
33439 WESTERN AVENUE • UNION CITY, CALIFORNIA 94587-3201 • PHONE (510) 489-6300 • FAX (510) 489-6372

Electromagnetic Compatibility Criteria Test Report

for the

**Firetide, Inc.
Model 7200 Outdoor Unit**

Tested under

the Certification Rules
contained in

Title 47 of the CFR, Part 15, Subpart B and
ICES-003 Issue 4 February 2004
for Unintentional Radiators
and

Title 47 of the CFR, Part 15.407 and
Industry Canada RSS-210, Issue 7, June 2007
for Intentional Radiators

MET Report: EMCS81748C-FCC407 Rev. 1

January 13, 2010

Prepared For:

**Firetide, Inc.
16795 Lark Ave. Suite 200
Los Gatos, CA 95032**

Prepared By:
MET Laboratories, Inc.
914 W. Patapsco Ave.
Baltimore, MD 21230

Electromagnetic Compatibility Criteria Test Report

for the

Firetide, Inc.
Model 7200 Outdoor Unit

the Certification Rules
contained in
Title 47 of the CFR, Part 15, Subpart B and
ICES-003 Issue 4 February 2004
for Unintentional Radiators
and
Title 47 of the CFR, Part 15.407 and
Industry Canada RSS-210, Issue 7, June 2007
for Intentional Radiators



Minh Ly, Project Engineer
Electromagnetic Compatibility Lab



Jennifer Warnell
Documentation Department

Engineering Statement: The measurements shown in this report were made in accordance with the procedures indicated, and the emissions from this equipment were found to be within the limits applicable. I assume full responsibility for the accuracy and completeness of these measurements, and for the qualifications of all persons taking them. It is further stated that upon the basis of the measurements made, the equipment tested is capable of operation in accordance with the requirements of Parts 15B, 15.407, of the FCC Rules and ICES-003 and RSS-210 of the Industry Canada rules under normal use and maintenance.



Shawn McMillen, Wireless Manager
Electromagnetic Compatibility Lab

Report Status Sheet

Revision	Report Date	Reason for Revision
Ø	December 23, 2009	Initial Issue.
1	January 13, 2010	Revised to incorporate various engineer corrections.

Table of Contents

I.	Executive Summary	1
	A. Purpose of Test	2
	B. Executive Summary	2
II.	Equipment Configuration	3
	A. Overview	4
	B. References	5
	C. Test Site	5
	D. Description of Test Sample	6
	E. Equipment Configuration	8
	F. Support Equipment	8
	G. Ports and Cabling Information	8
	H. Mode of Operation	9
	I. Method of Monitoring EUT Operation	9
	J. Modifications	9
	a) Modifications to EUT	9
	b) Modifications to Test Standard	9
	K. Disposition of EUT	9
III.	Electromagnetic Compatibility Criteria for Unintentional Radiators	10
	§ 15.107(a) Conducted Emissions Limits	11
	§ 15.109(a) Radiated Emissions Limits	14
IV.	Electromagnetic Compatibility Criteria for Intentional Radiators	19
	§ 15.203 Antenna Requirement	20
	§ 15.207 Conducted Emissions Limits	21
	§ 15.403(c) 26dB Bandwidth	24
	§ 15.407(a) RF Power Output	33
	§ 15.407(a)(1)(2) Peak Power Spectral Density	42
	§ 15.407(a)(6) Peak Excursion Ratio	53
	§ 15.407(b) Undesirable Emissions	62
	a) Radiated Harmonic Emissions	64
	b) Radiated Spurious Emissions	74
	c) EIRP	96
	§ 15.407(f) RF Exposure	114
	§ 15.407(g) Frequency Stability	115
V.	Test Equipment	125
VI.	Certification & User's Manual Information	127
	A. Certification Information	128
	B. Label and User's Manual Information	132
VII.	ICES-003 Procedural & Labeling Requirements	134

List of Tables

Table 1. Executive Summary of EMC Part 15.407 Compliance Testing	2
Table 2. EUT Summary	4
Table 3. References	5
Table 4. Equipment Configuration	8
Table 5. Support Equipment	8
Table 6. Ports and Cabling Information	8
Table 7. Conducted Limits for Radio Frequency Devices calculated from FCC Part 15 Subsections 15.107(a) (b) and 15.207(a)	11
Table 8. Conducted Emissions - Voltage, AC Power, Test Results	12

Table 9. Radiated Emissions Limits calculated from FCC Part 15, §15.109 (a) (b)	14
Table 10. Radiated Emissions, Test Results, FCC Limits, 30 MHz – 1 GHz	15
Table 11. Radiated Emissions, Test Results, FCC Limits, 1GHz – 6GHz	16
Table 12. Radiated Emissions, Test Results, ICES-003 Limits, 30 MHz – 1 GHz	17
Table 13. Antenna Information	20
Table 14. Conducted Limits for Intentional Radiators from FCC Part 15 § 15.207(a)	21
Table 15. Conducted Emissions - Voltage, AC Power, Test Results	22
Table 16. Occupied Bandwidth, Port 1, Test Results	25
Table 17. Occupied Bandwidth, Port 2, Test Results	25
Table 18. Occupied Bandwidth, Port 3, Test Results	25
Table 19. Output Power Requirements from §15.407	33
Table 20. RF Power Output, Test Results, Port 1	34
Table 21. RF Power Output, Test Results, Port 2	34
Table 22. RF Power Output, Test Results, Port 3	34
Table 23. RF Power Output, Test Results, Summed Power	34
Table 24. Peak Power Spectral Density, Test Results, Port 1	43
Table 25. Peak Power Spectral Density, Test Results, Port 2	43
Table 26. Peak Power Spectral Density, Test Results, Port 3	43
Table 27. Peak Power Spectral Density, Test Results, Combined Ports	43
Table 28. Peak Excursion Ration, Test Results, Port 1	53
Table 29. Peak Excursion Ration, Test Results, Port 2	54
Table 30. Peak Excursion Ration, Test Results, Port 3	54
Table 31. Restricted Bands of Operation.....	62
Table 32. Radiated Harmonics, 802.11a, 5 dBi Omni, 5745 MHz.....	64
Table 33. Radiated Harmonics, 802.11a, 5 dBi Omni, 5785 MHz.....	64
Table 34. Radiated Harmonics, 802.11a, 5 dBi Omni, 5805 MHz.....	64
Table 35. Radiated Harmonics, 802.11a, 9 dBi Omni, 5745 MHz.....	65
Table 36. Radiated Harmonics, 802.11a, 9 dBi Omni, 5785 MHz.....	65
Table 37. Radiated Harmonics, 802.11a, 9 dBi Omni, 5805 MHz.....	65
Table 38. Radiated Harmonics, 802.11a, 16 dBi Sector, 5745 MHz.....	66
Table 39. Radiated Harmonics, 802.11a, 16 dBi Sector, 5785 MHz.....	66
Table 40. Radiated Harmonics, 802.11a, 16 dBi Sector, 5805 MHz.....	66
Table 41. Radiated Harmonics, 802.11a, 19 dBi Panel, 5745 MHz.....	67
Table 42. Radiated Harmonics, 802.11a, 19 dBi Panel, 5785 MHz.....	67
Table 43. Radiated Harmonics, 802.11a, 19 dBi Panel, 5805 MHz.....	67
Table 44. Radiated Harmonics, 802.11n 20MHz, 5 dBi Omni, 5745 MHz	68
Table 45. Radiated Harmonics, 802.11n 20MHz, 5 dBi Omni, 5785 MHz	68
Table 46. Radiated Harmonics, 802.11n 20MHz, 5 dBi Omni, 5805 MHz	68
Table 47. Radiated Harmonics, 802.11n 20MHz, 9 dBi Omni, 5745 MHz	69
Table 48. Radiated Harmonics, 802.11n 20MHz, 9 dBi Omni, 5785 MHz	69
Table 49. Radiated Harmonics, 802.11n 20MHz, 9 dBi Omni, 5805 MHz	69
Table 50. Radiated Harmonics, 802.11n 20MHz, 16 dBi Sector, 5745 MHz	70
Table 51. Radiated Harmonics, 802.11n 20MHz, 16 dBi Sector, 5785 MHz	70
Table 52. Radiated Harmonics, 802.11n 20MHz, 16 dBi Sector, 5805 MHz	70
Table 53. Radiated Harmonics, 802.11n 20MHz, 19 dBi Panel, 5745 MHz.....	71
Table 54. Radiated Harmonics, 802.11n 20MHz, 19 dBi Panel, 5785 MHz.....	71
Table 55. Radiated Harmonics, 802.11n 20MHz, 19 dBi Panel, 5805 MHz.....	71
Table 56. Radiated Harmonics, 802.11n 40MHz, 5 dBi Omni, 5755 MHz	72
Table 57. Radiated Harmonics, 802.11n 40MHz, 5 dBi Omni, 5795 MHz	72
Table 58. Radiated Harmonics, 802.11n 40MHz, 9 dBi Omni, 5755 MHz	72
Table 59. Radiated Harmonics, 802.11n 40MHz, 9 dBi Omni, 5795 MHz	72
Table 60. Radiated Harmonics, 802.11n 40MHz, 16 dBi Sector, 5755 MHz	73
Table 61. Radiated Harmonics, 802.11n 40MHz, 16 dBi Sector, 5795 MHz	73
Table 62. Radiated Harmonics, 802.11n 40MHz, 19 dBi Panel, 5755 MHz.....	73
Table 63. Radiated Harmonics, 802.11n 40MHz, 19 dBi Panel, 5795 MHz.....	73
Table 64. EIRP Calculation, 5 dBi Omni	96

Table 65. EIRP Calculation, 9 dBi Omni	96
Table 66. EIRP Calculation, 16 dBi Sector	96
Table 67. EIRP Calculation, 19 dBi Panel	96
Table 68. Test Equipment List	126

List of Figures

Figure 1. Block Diagram of Test Configuration.....	7
Figure 2. Occupied Bandwidth Test Setup.....	24
Figure 3. Peak Power Output Test Setup.....	33
Figure 4. Peak Power Spectral Density Test Setup	42

List of Photographs

Photograph 1. Firetide, Inc. 7200 Outdoor Unit.....	6
Photograph 2. Conducted Emissions, Test Setup.....	13
Photograph 3. Radiated Emission Test Setup 30 MHz – 1 GHz	18
Photograph 4. Radiated Emission Test Setup 1 GHz – 6 GHz.....	18
Photograph 5. Conducted Emissions, Test Setup	23
Photograph 6. Test Equipment and Setup for Various Radiated Measurements, 9 dBi Omni	112
Photograph 7. Test Equipment and Setup for Various Radiated Measurements, 16 dBi Sector	112
Photograph 8. Test Equipment and Setup for Various Radiated Measurements, 19 dBi Panel.....	113

List of Plots

Plot 1. Conducted Emission, Phase Line Plot	12
Plot 2. Conducted Emission, Neutral Line Plot.....	13
Plot 3. Radiated Emissions, Pre-Scan, FCC Limits, 30 MHz – 1 GHz	15
Plot 4. Radiated Emissions, Pre-Scan, FCC Limits, 1 GHz – 6 GHz.....	16
Plot 5. Radiated Emissions, Pre-Scan, ICES-003 Limits, 30 MHz – 1 GHz.....	17
Plot 6. §15.207 Conducted Emissions, Phase Line Plot, 7200 Outdoor Unit.....	22
Plot 7. §15.207 Conducted Emissions, Neutral Line Plot, 7200 Outdoor Unit	23
Plot 8. Occupied Bandwidth, Port 1, 802.11a, 5745 MHz	26
Plot 9. Occupied Bandwidth, Port 1, 802.11a, 5785 MHz	26
Plot 10. Occupied Bandwidth, Port 1, 802.11a, 5805 MHz	26
Plot 11. Occupied Bandwidth, Port 1, 802.11n 20MHz, 5745 MHz	27
Plot 12. Occupied Bandwidth, Port 1, 802.11n 20MHz, 5785 MHz	27
Plot 13. Occupied Bandwidth, Port 1, 802.11n 20MHz, 5805 MHz	27
Plot 14. Occupied Bandwidth, Port 1, 802.11n 40MHz, 5755 MHz	28
Plot 15. Occupied Bandwidth, Port 1, 802.11n 40MHz, 5795 MHz	28
Plot 16. Occupied Bandwidth, Port 2, 802.11n 20MHz, 5745 MHz	29
Plot 17. Occupied Bandwidth, Port 2, 802.11n 20MHz, 5785 MHz	29
Plot 18. Occupied Bandwidth, Port 2, 802.11n 20MHz, 5805 MHz	29
Plot 19. Occupied Bandwidth, Port 2, 802.11n 40MHz, 5755 MHz	30
Plot 20. Occupied Bandwidth, Port 2, 802.11n 40MHz, 5795 MHz	30
Plot 21. Occupied Bandwidth, Port 3, 802.11n 20MHz, 5745 MHz	31
Plot 22. Occupied Bandwidth, Port 3, 802.11n 20MHz, 5785 MHz	31
Plot 23. Occupied Bandwidth, Port 3, 802.11n 20MHz, 5805 MHz	31
Plot 24. Occupied Bandwidth, Port 3, 802.11n 40MHz, 5755 MHz	32
Plot 25. Occupied Bandwidth, Port 3, 802.11n 40MHz, 5795 MHz	32
Plot 26. RF Power Output, Port 1, 802.11a, 5745 MHz	35
Plot 27. RF Power Output, Port 1, 802.11a, 5785 MHz	35
Plot 28. RF Power Output, Port 1, 802.11a, 5805 MHz	35
Plot 29. RF Power Output, Port 1, 802.11n 20MHz, 5745 MHz.....	36
Plot 30. RF Power Output, Port 1, 802.11n 20MHz, 5785 MHz.....	36
Plot 31. RF Power Output, Port 1, 802.11n 20MHz, 5805 MHz.....	36
Plot 32. RF Power Output, Port 1, 802.11n 40MHz, 5755 MHz.....	37
Plot 33. RF Power Output, Port 1, 802.11n 40MHz, 5795 MHz.....	37
Plot 34. RF Power Output, Port 2, 802.11n 20MHz, 5745 MHz.....	38
Plot 35. RF Power Output, Port 2, 802.11n 20MHz, 5785 MHz.....	38
Plot 36. RF Power Output, Port 2, 802.11n 20MHz, 5805 MHz.....	38
Plot 37. RF Power Output, Port 2, 802.11n 40MHz, 5755 MHz.....	39
Plot 38. RF Power Output, Port 2, 802.11n 40MHz, 5795 MHz.....	39
Plot 39. RF Power Output, Port 3, 802.11n 20MHz, 5745 MHz.....	40
Plot 40. RF Power Output, Port 3, 802.11n 20MHz, 5785 MHz.....	40
Plot 41. RF Power Output, Port 3, 802.11n 20MHz, 5805 MHz.....	40
Plot 42. RF Power Output, Port 3, 802.11n 40MHz, 5755 MHz.....	41
Plot 43. RF Power Output, Port 3, 802.11n 40MHz, 5795 MHz.....	41
Plot 44. PPSD, Port 1, 802.11a, 5745 MHz.....	44
Plot 45. PPSD, Port 1, 802.11a 2, 5785 MHz.....	44
Plot 46. PPSD, Port 1, 802.11a, 5805 MHz.....	44
Plot 47. PPSD, \ Port 1, 802.11an 20MHz, 5745 MHz	45
Plot 48. PPSD, Port 1, 802.11an 20MHz, 5785 MHz	45
Plot 49. PPSD, Port 1, 802.11an 20MHz, 5805 MHz	45
Plot 50. PPSD, Port 1, 802.11n 40MHz, 5755 MHz	46
Plot 51. PPSD, Port 1, 802.11n 40MHz, 5795 MHz	46
Plot 52. PPSD, Port 2, 802.11n 20MHz, 5745 MHz	47

Plot 53. PPSD, Port 2, 802.11n 20MHz, 5785 MHz	47
Plot 54. PPSD, Port 2, 802.11n 20MHz, 5805 MHz	47
Plot 55. PPSD, Port 2, 802.11n 40MHz, 5755 MHz	48
Plot 56. PPSD, Port 2, 802.11n 40MHz, 5795 MHz	48
Plot 57. PPSD, Port 3, 802.11n 20MHz, 5745 MHz	49
Plot 58. PPSD, Port 3, 802.11n 20MHz, 5785 MHz	49
Plot 59. PPSD, Port 3, 802.11n 20MHz, 5805 MHz	49
Plot 60. PPSD, Port 3, 802.11n 40MHz, 5755 MHz	50
Plot 61. PPSD, Port 3, 802.11n 40MHz, 5795 MHz	50
Plot 62. PPSD, Combined Ports, 802.11n 20MHz, 5745 MHz	51
Plot 63. PPSD, Combined Ports, 802.11n 20MHz, 5785 MHz	51
Plot 64. PPSD, Combined Ports, 802.11n 20MHz, 5805 MHz	51
Plot 65. PPSD, Combined Ports, 802.11n 40MHz, 5755 MHz	52
Plot 66. PPSD, Combined Ports, 802.11n 40MHz, 5795 MHz	52
Plot 67. Peak Excursion, Port 1, 802.11a, 5745 MHz	55
Plot 68. Peak Excursion, Port 1, 802.11a, 5785 MHz	55
Plot 69. Peak Excursion, Port 1, 802.11a, 5805 MHz	55
Plot 70. Peak Excursion, Port 1, 802.11n 20MHz, 5745 MHz	56
Plot 71. Peak Excursion, Port 1, 802.11n 20MHz, 5785 MHz	56
Plot 72. Peak Excursion, Port 1, 802.11n 20MHz, 5805 MHz	56
Plot 73. Peak Excursion, Port 1, 802.11n 40MHz, 5755 MHz	57
Plot 74. Peak Excursion, Port 1, 802.11n 40MHz, 5795 MHz	57
Plot 75. Peak Excursion, Port 2, 802.11n 20MHz, 5745 MHz	58
Plot 76. Peak Excursion, Port 2, 802.11n 20MHz, 5785 MHz	58
Plot 77. Peak Excursion, Port 2, 802.11n 20MHz, 5805 MHz	58
Plot 78. Peak Excursion, Port 2, 802.11n 40MHz, 5755 MHz	59
Plot 79. Peak Excursion, Port 2, 802.11n 40MHz, 5795 MHz	59
Plot 80. Peak Excursion, Port 3, 802.11n 20MHz, 5745 MHz	60
Plot 81. Peak Excursion, Port 3, 802.11n 20MHz, 5785 MHz	60
Plot 82. Peak Excursion, Port 3, 802.11n 20MHz, 5805 MHz	60
Plot 83. Peak Excursion, Port 3, 802.11n 40MHz, 5755 MHz	61
Plot 84. Peak Excursion, Port 3, 802.11n 40MHz, 5795 MHz	61
Plot 85. Radiated Spurious, 802.11a, 5745 MHz, 30 MHz – 1 GHz, 5 dBi Omni	74
Plot 86. Radiated Spurious, 802.11a, 5745 MHz, 1 GHz – 18 GHz, 5 dBi Omni	74
Plot 87. Radiated Spurious, 802.11a, 5785 MHz, 30 MHz – 1 GHz, 5 dBi Omni	74
Plot 88. Radiated Spurious, 802.11a, 5785 MHz, 1 GHz – 18 GHz, 5 dBi Omni	75
Plot 89. Radiated Spurious, 802.11a, 5805 MHz, 30 MHz – 1 GHz, 5 dBi Omni	75
Plot 90. Radiated Spurious, 802.11a, 5805 MHz, 1 GHz – 18 GHz, 5 dBi Omni	75
Plot 91. Radiated Spurious, 802.11a, 5745 MHz, 30 MHz – 1 GHz, 9 dBi Omni	76
Plot 92. Radiated Spurious, 802.11a, 5745 MHz, 1 GHz – 18 GHz, 9 dBi Omni	76
Plot 93. Radiated Spurious, 802.11a, 5785 MHz, 30 MHz – 1 GHz, 9 dBi Omni	76
Plot 94. Radiated Spurious, 802.11a, 5785 MHz, 1 GHz – 18 GHz, 9 dBi Omni	77
Plot 95. Radiated Spurious, 802.11a, 5805 MHz, 30 MHz – 1 GHz, 9 dBi Omni	77
Plot 96. Radiated Spurious, 802.11a, 5805 MHz, 1 GHz – 18 GHz, 9 dBi Omni	77
Plot 97. Radiated Spurious, 802.11a, 5745 MHz, 30 MHz – 1 GHz, 16 dBi Sector	78
Plot 98. Radiated Spurious, 802.11a, 5745 MHz, 1 GHz – 18 GHz, 16 dBi Sector	78
Plot 99. Radiated Spurious, 802.11a, 5785 MHz, 30 MHz – 1 GHz, 16 dBi Sector	78
Plot 100. Radiated Spurious, 802.11a, 5785 MHz, 1 GHz – 18 GHz, 16 dBi Sector	79
Plot 101. Radiated Spurious, 802.11a, 5805 MHz, 30 MHz – 1 GHz, 16 dBi Sector	79
Plot 102. Radiated Spurious, 802.11a, 5805 MHz, 1 GHz – 18 GHz, 16 dBi Sector	79
Plot 103. Radiated Spurious, 802.11a, 5745 MHz, 30 MHz – 1 GHz, 19 dBi Panel	80
Plot 104. Radiated Spurious, 802.11a, 5745 MHz, 1 GHz – 18 GHz, 19 dBi Panel	80
Plot 105. Radiated Spurious, 802.11a, 5785 MHz, 30 MHz – 1 GHz, 19 dBi Panel	80
Plot 106. Radiated Spurious, 802.11a, 5785 MHz, 1 GHz – 18 GHz, 19 dBi Panel	81
Plot 107. Radiated Spurious, 802.11a, 5805 MHz, 30 MHz – 1 GHz, 19 dBi Panel	81
Plot 108. Radiated Spurious, 802.11a, 5805 MHz, 1 GHz – 18 GHz, 19 dBi Panel	81

Plot 109. Radiated Spurious, 802.11n 20MHz, 5745 MHz, 30 MHz – 1 GHz, 5 dBi Omni.....	82
Plot 110. Radiated Spurious, 802.11n 20MHz, 5745 MHz, 1 GHz – 18 GHz, 5 dBi Omni	82
Plot 111. Radiated Spurious, 802.11n 20MHz, 5785 MHz, 30 MHz – 1 GHz, 5 dBi Omni.....	82
Plot 112. Radiated Spurious, 802.11n 20MHz, 5785 MHz, 1 GHz – 18 GHz, 5 dBi Omni	83
Plot 113. Radiated Spurious, 802.11n 20MHz, 5805 MHz, 30 MHz – 1 GHz, 5 dBi Omni.....	83
Plot 114. Radiated Spurious, 802.11n 20MHz, 5805 MHz, 1 GHz – 18 GHz, 5 dBi Omni	83
Plot 115. Radiated Spurious, 802.11n 20MHz, 5745 MHz, 30 MHz – 1 GHz, 9 dBi Omni.....	84
Plot 116. Radiated Spurious, 802.11n 20MHz, 5745 MHz, 1 GHz – 18 GHz, 9 dBi Omni	84
Plot 117. Radiated Spurious, 802.11n 20MHz, 5785 MHz, 30 MHz – 1 GHz, 9 dBi Omni.....	84
Plot 118. Radiated Spurious, 802.11n 20MHz, 5785 MHz, 1 GHz – 18 GHz, 9 dBi Omni	85
Plot 119. Radiated Spurious, 802.11n 20MHz, 5805 MHz, 30 MHz – 1 GHz, 9 dBi Omni.....	85
Plot 120. Radiated Spurious, 802.11n 20MHz, 5805 MHz, 1 GHz – 18 GHz, 9 dBi Omni	85
Plot 121. Radiated Spurious, 802.11n 20MHz, 5745 MHz, 30 MHz – 1 GHz, 16 dBi Sector.....	86
Plot 122. Radiated Spurious, 802.11n 20MHz, 5745 MHz, 1 GHz – 18 GHz, 16 dBi Sector	86
Plot 123. Radiated Spurious, 802.11n 20MHz, 5785 MHz, 30 MHz – 1 GHz, 16 dBi Sector.....	86
Plot 124. Radiated Spurious, 802.11n 20MHz, 5785 MHz, 1 GHz – 18 GHz, 16 dBi Sector	87
Plot 125. Radiated Spurious, 802.11n 20MHz, 5805 MHz, 30 MHz – 1 GHz, 16 dBi Sector.....	87
Plot 126. Radiated Spurious, 802.11n 20MHz, 5805 MHz, 1 GHz – 18 GHz, 16 dBi Sector	87
Plot 127. Radiated Spurious, 802.11n 20MHz, 5745 MHz, 30 MHz – 1 GHz, 19 dBi Panel.....	88
Plot 128. Radiated Spurious, 802.11n 20MHz, 5745 MHz, 1 GHz – 18 GHz, 19 dBi Panel.....	88
Plot 129. Radiated Spurious, 802.11n 20MHz, 5785 MHz, 30 MHz – 1 GHz, 19 dBi Panel.....	88
Plot 130. Radiated Spurious, 802.11n 20MHz, 5785 MHz, 1 GHz – 18 GHz, 19 dBi Panel.....	89
Plot 131. Radiated Spurious, 802.11n 20MHz, 5805 MHz, 30 MHz – 1 GHz, 19 dBi Panel.....	89
Plot 132. Radiated Spurious, 802.11n 20MHz, 5805 MHz, 1 GHz – 18 GHz, 19 dBi Panel.....	89
Plot 133. Radiated Spurious, 802.11n 40MHz, 5755 MHz, 30 MHz – 1 GHz, 5 dBi Omni.....	90
Plot 134. Radiated Spurious, 802.11n 40MHz, 5755 MHz, 1 GHz – 18 GHz, 5 dBi Omni	90
Plot 135. Radiated Spurious, 802.11n 40MHz, 5795 MHz, 30 MHz – 1 GHz, 5 dBi Omni.....	90
Plot 136. Radiated Spurious, 802.11n 40MHz, 5795 MHz, 1 GHz – 18 GHz, 5 dBi Omni	91
Plot 137. Radiated Spurious, 802.11n 40MHz, 5755 MHz, 30 MHz – 1 GHz, 9 dBi Omni.....	91
Plot 138. Radiated Spurious, 802.11n 40MHz, 5755 MHz, 1 GHz – 18 GHz, 9 dBi Omni	91
Plot 139. Radiated Spurious, 802.11n 40MHz, 5795 MHz, 30 MHz – 1 GHz, 9 dBi Omni.....	92
Plot 140. Radiated Spurious, 802.11n 40MHz, 5795 MHz, 1 GHz – 18 GHz, 9 dBi Omni	92
Plot 141. Radiated Spurious, 802.11n 40MHz, 5755 MHz, 30 MHz – 1 GHz, 16 dBi Sector.....	92
Plot 142. Radiated Spurious, 802.11n 40MHz, 5755 MHz, 1 GHz – 18 GHz, 16 dBi Sector	93
Plot 143. Radiated Spurious, 802.11n 40MHz, 5795 MHz, 30 MHz – 1 GHz, 16 dBi Sector.....	93
Plot 144. Radiated Spurious, 802.11n 40MHz, 5795 MHz, 1 GHz – 18 GHz, 16 dBi Sector	93
Plot 145. Radiated Spurious, 802.11n 40MHz, 5755 MHz, 30 MHz – 1 GHz, 19 dBi Panel.....	94
Plot 146. Radiated Spurious, 802.11n 40MHz, 5755 MHz, 1 GHz – 18 GHz, 19 dBi Panel.....	94
Plot 147. Radiated Spurious, 802.11n 40MHz, 5795 MHz, 30 MHz – 1 GHz, 19 dBi Panel.....	94
Plot 148. Radiated Spurious, 802.11n 40MHz, 5795 MHz, 1 GHz – 18 GHz, 19 dBi Panel.....	95
Plot 149. EIRP, 802.11a, Low Channel, 5745 MHz, 5 dBi Omni.....	97
Plot 150. EIRP, 802.11a, High Channel, 5805 MHz, 5 dBi Omni	97
Plot 151. EIRP, 802.11a, Low Channel 5745 MHz, 9 dBi Omni.....	97
Plot 152. EIRP, 802.11a, High Channel 5805 MHz, 9 dBi Omni	98
Plot 153. EIRP, 802.11a, Low Channel, 5745 MHz, 16 dBi Sector.....	98
Plot 154. EIRP, 802.11a, Low Channel, 5745 MHz Over 1 MHz, 16 dBi Sector.....	98
Plot 155. EIRP, 802.11a, High Channel 5805 MHz, 16 dBi Sector	99
Plot 156. EIRP, 802.11a, High Channel, 5805 MHz Over 1 MHz, 16 dBi Sector.....	99
Plot 157. EIRP, 802.11a, Low Channel, 5745 MHz, 19 dBi Panel	99
Plot 158. EIRP, 802.11a, Low Channel, 5745 MHz Over 1 MHz, 19 dBi Panel.....	100
Plot 159. EIRP, 802.11a, High Channel, 5805 MHz, 19 dBi Panel	100
Plot 160. EIRP, 802.11a, High Channel, 5805 MHz Over 1 MHz, 19 dBi Panel	100
Plot 161. EIRP, 802.11n 20MHz, Low Channel, 5725 MHz, 5 dBi Omni.....	101
Plot 162. EIRP, 802.11n 20MHz, High Channel, 5080 MHz Over 1 MHz, 5 dBi Omni.....	101
Plot 163. EIRP, 802.11n 20MHz, Low Channel, 5745 MHz, 9 dBi Omni.....	101
Plot 164. EIRP, 802.11n 20MHz, High Channel, 5805 MHz, 9 dBi Omni.....	102

Plot 165. EIRP, 802.11n 20MHz, High Channel, 5805 MHz Over 1 MHz, 9 dBi Omni.....	102
Plot 166. EIRP, 802.11n 20MHz, Low Channel, 5745 MHz, 16 dBi Sector	102
Plot 167. EIRP, 802.11n 20MHz, Low Channel, 5745 MHz Over 1 MHz, 16 dBi Sector	103
Plot 168. EIRP, 802.11n 20MHz, High Channel, 5805 MHz, 16 dBi Sector.....	103
Plot 169. EIRP, 802.11n 20MHz, High Channel, 5805 MHz Over 1 MHz, 16 dBi Sector.....	103
Plot 170. EIRP, 802.11n 20MHz, Low Channel, 5745 MHz, 19 dBi Panel.....	104
Plot 171. EIRP, 802.11n 20MHz, Low Channel, 5745 MHz Over 1 MHz, 19 dBi Panel.....	104
Plot 172. EIRP, 802.11n 20MHz, High Channel, 5805 MHz, 19 dBi Panel	104
Plot 173. EIRP, 802.11n 20MHz, High Channel, 5805MHz Over 1 MHz, 19 dBi Panel.....	105
Plot 174. EIRP, 802.11n 40MHz, Low Channel, 5755 MHz, 5 dBi Omni.....	106
Plot 175. EIRP, 802.11n 40MHz, Low Channel, 5755 MHz Over 1 MHz, 5 dBi Omni	106
Plot 176. EIRP, 802.11n 40MHz, High Channel, 5795 MHz, 5 dBi Omni	106
Plot 177. EIRP, 802.11n 40MHz, High Channel, 5895 MHz Over 1 MHz, 5 dBi Omni.....	107
Plot 178. EIRP, 802.11n 40MHz, Low Channel, 5755 MHz, 9 dBi Omni.....	107
Plot 179. EIRP, 802.11n 40MHz, Low Channel, 5755 MHz Over 1 MHz, 9 dBi Omni	107
Plot 180. EIRP, 802.11n 40MHz, High Channel, 5795 MHz, 9 dBi Omni.....	108
Plot 181. EIRP, 802.11n 40MHz, High Channel, 5795 MHz Over 1 MHz, 9 dBi Omni.....	108
Plot 182. EIRP, 802.11n 40MHz, Low Channel, 5755 MHz, 16 dBi Sector	108
Plot 183. EIRP, 802.11n 40MHz, Low Channel, 5755 MHz Over 1 MHz, 16 dBi Sector	109
Plot 184. EIRP, 802.11n 40MHz, High Channel, 5795 MHz, 16 dBi Sector.....	109
Plot 185. EIRP, 802.11n 40MHz, High Channel, 5795 MHz Over 1 MHz, 16 dBi Sector.....	109
Plot 186. EIRP, 802.11n 40MHz, Low Channel, 5755 MHz, 19 dBi Panel.....	110
Plot 187. EIRP, 802.11n 40MHz, Low Channel, 5755 MHz Over 1 MHz, 19 dBi Panel.....	110
Plot 188. EIRP, 802.11n 40MHz, High Channel, 5795 MHz, 19 dBi Panel	110
Plot 189. EIRP, 802.11n 40MHz, High Channel, 5795 MHz Over 1 MHz, 19 dBi Panel.....	111
Plot 190. Frequency Stability, 802.11a 20MHz Bandwidth, -40C, 108 VAC.....	116
Plot 191. Frequency Stability, 802.11a 20MHz Bandwidth, -40C, 120 VAC.....	116
Plot 192. Frequency Stability, 802.11a 20MHz Bandwidth, -40C, 132 VAC.....	116
Plot 193. Frequency Stability, 802.11a 20MHz Bandwidth, 20C, 108 VAC	117
Plot 194. Frequency Stability, 802.11a 20MHz Bandwidth, 20C, 120 VAC	117
Plot 195. Frequency Stability, 802.11a 20MHz Bandwidth, 20C, 132 VAC	117
Plot 196. Frequency Stability, 802.11a 20MHz Bandwidth, 60C, 108 VAC	118
Plot 197. Frequency Stability, 802.11a 20MHz Bandwidth, 60C, 120 VAC	118
Plot 198. Frequency Stability, 802.11a 20MHz Bandwidth, 60C, 132 VAC	118
Plot 199. Frequency Stability, 802.11n 20MHz Bandwidth, -40C, 108 VAC.....	119
Plot 200. Frequency Stability, 802.11n 20MHz Bandwidth, -40C, 120 VAC.....	119
Plot 201. Frequency Stability, 802.11n 20MHz Bandwidth, -40C, 132 VAC.....	119
Plot 202. Frequency Stability, 802.11n 20MHz Bandwidth, 20C, 108 VAC.....	120
Plot 203. Frequency Stability, 802.11n 20MHz Bandwidth, 20C, 120 VAC.....	120
Plot 204. Frequency Stability, 802.11n 20MHz Bandwidth, 20C, 132 VAC.....	120
Plot 205. Frequency Stability, 802.11n 20MHz Bandwidth, 60C, 108 VAC.....	121
Plot 206. Frequency Stability, 802.11n 20MHz Bandwidth, 60C, 120 VAC.....	121
Plot 207. Frequency Stability, 802.11n 20MHz Bandwidth, 60C, 132 VAC.....	121
Plot 208. Frequency Stability, 802.11n 40MHz Bandwidth, -40C, 108 VAC.....	122
Plot 209. Frequency Stability, 802.11n 40MHz Bandwidth, -40C, 120 VAC.....	122
Plot 210. Frequency Stability, 802.11n 40MHz Bandwidth, -40C, 132 VAC.....	122
Plot 211. Frequency Stability, 802.11n 40MHz Bandwidth, 20C, 108 VAC.....	123
Plot 212. Frequency Stability, 802.11n 40MHz Bandwidth, 20C, 120 VAC.....	123
Plot 213. Frequency Stability, 802.11n 40MHz Bandwidth, 20C, 132 VAC.....	123
Plot 214. Frequency Stability, 802.11n 40MHz Bandwidth, 60C, 108 VAC.....	124
Plot 215. Frequency Stability, 802.11n 40MHz Bandwidth, 60C, 120 VAC.....	124
Plot 216. Frequency Stability, 802.11n 40MHz Bandwidth, 60C, 132 VAC.....	124

List of Terms and Abbreviations

AC	Alternating Current
ACF	Antenna Correction Factor
Cal	Calibration
<i>d</i>	Measurement Distance
dB	Decibels
dB μ A	Decibels above one microamp
dB μ V	Decibels above one microvolt
dB μ A/m	Decibels above one microamp per meter
dB μ V/m	Decibels above one microvolt per meter
DC	Direct Current
E	Electric Field
DSL	Digital Subscriber Line
ESD	Electrostatic Discharge
EUT	Equipment Under Test
<i>f</i>	Frequency
FCC	Federal Communications Commission
GRP	Ground Reference Plane
H	Magnetic Field
HCP	Horizontal Coupling Plane
Hz	Hertz
IEC	International Electrotechnical Commission
kHz	kilohertz
kPa	kilopascal
kV	kilovolt
LISN	Line Impedance Stabilization Network
MHz	Megahertz
μ H	microhenry
μ	microfarad
μ s	microseconds
PRF	Pulse Repetition Frequency
RF	Radio Frequency
RMS	Root-Mean-Square
TWT	Traveling Wave Tube
V/m	Volts per meter
VCP	Vertical Coupling Plane

I. Executive Summary

A. Purpose of Test

An EMC evaluation was performed to determine compliance of the Firetide, Inc. 7200 Outdoor Unit, with the requirements of Part 15, §15.407. All references are to the most current version of Title 47 of the Code of Federal Regulations in effect. In accordance with §2.1033, the following data is presented in support of the Certification of the 7200 Outdoor Unit. Firetide, Inc. should retain a copy of this document which should be kept on file for at least two years after the manufacturing of the 7200 Outdoor Unit, has been **permanently** discontinued.

B. Executive Summary

The following tests were conducted on a sample of the equipment for the purpose of demonstrating compliance with Part 15, §15.407, in accordance with Firetide, Inc., purchase order number 2475. All tests were conducted using measurement procedure ANSI C63.4-2003.

FCC Reference	Industry Canada Reference	Description	Results
15.107	ICES-003 Issue 4 February 2004	Conducted Emissions	Compliant
15.109		Radiated Emissions	Compliant
15.203	RSS-GEN 7.1.4	Antenna Requirements	Compliant
15.205/15.209	2.2	General Field Strength Limits (Restricted Bands and Radiated Emission Limits)	Compliant
15.207	RSS-GEN 7.2.2; RSS-210 2.2	AC Conducted Emissions 150KHz – 30MHz	Compliant
15.403 (c)	A8.2	26dB Occupied Bandwidth	Compliant
15.407 (a)(1), (2), (3)	A9.2(3)	Conducted Transmitter Output Power	Compliant
15.407 (a)(1), (2), (3), (5)	A9.2(3)	Power Spectral Density	Compliant
15.407 (a)(6)	A8.2	Peak Excursion	Compliant
15.407 (b)(1), (2), (5), (6)	A9.3(4)	Undesirable Emissions	Compliant
15.407(f)	RSS-GEN	RF Exposure	Compliant
15.407(g)	2.1	Frequency Stability	Compliant

Table 1. Executive Summary of EMC Part 15.407 Compliance Testing

II. Equipment Configuration

A. Overview

MET Laboratories, Inc. was contracted by Firetide, Inc. to perform testing on the 7200 Outdoor Unit, under Firetide, Inc.'s purchase order number 2475.

This document describes the test setups, test methods, required test equipment, and the test limit criteria used to perform compliance testing of the Firetide, Inc. 7200 Outdoor Unit.

The results obtained relate only to the item(s) tested.

Model(s) Tested:	7200 Outdoor Unit			
Model(s) Covered:	7200 Outdoor Unit			
EUT Specifications:	Primary Power: 100- 240VAC, 50Hz and 60Hz			
	FCC ID: REP-7200-1 IC: 4988A-7200			
	Type of Modulations:	OFDM		
	Emission Designators:	802.11a:	19M14D7D	
		802.11n 20MHz:	20M25D7D	
		802.11n 40MHz:	41M94D7D	
	Equipment Code:	NII		
	Peak RF Output Power:	802.11a:	17.24 dBm	
		802.11n 20MHz:	17.86 dBm	
		802.11n 40MHz:	18.14 dBm	
EUT Frequency Ranges:	5745 MHz – 5805MHz			
Analysis:	The results obtained relate only to the item(s) tested.			
Environmental Test Conditions:	Temperature: 15-35° C			
	Relative Humidity: 30-60%			
	Barometric Pressure: 860-1060 mbar			
Evaluated by:	Minh Ly			
Report Date(s):	January 13, 2010			

Table 2. EUT Summary

B. References

CFR 47, Part 15, Subpart B	Electromagnetic Compatibility: Criteria for Radio Frequency Devices
CFR 47, Part 15, Subpart E	Unlicensed National Information Infrastructure Devices (UNII)
RSS-210, Issue 7, June 2007	Low-power Licence-exempt Radiocommunications Devices (All Frequency Bands): Category I Equipment
ICES-003, Issue 4 February 2004	Electromagnetic Compatibility: Criteria for Radio Frequency Devices
ANSI C63.4:2003	Methods and Measurements of Radio-Noise Emissions from Low-Voltage Electrical And Electronic Equipment in the Range of 9 kHz to 40 GHz
ANSI/NCSL Z540-1-1994	Calibration Laboratories and Measuring and Test Equipment - General Requirements
ANSI/ISO/IEC 17025:2000	General Requirements for the Competence of Testing and Calibration Laboratories

Table 3. References

C. Test Site

All testing was performed at MET Laboratories, Inc., 3162 Belick Street, Santa Clara, CA 95054. All equipment used in making physical determinations is accurate and bears recent traceability to the National Institute of Standards and Technology.

Radiated Emissions measurements were performed in a 10 meter semi-anechoic chamber (equivalent to an Open Area Test Site). In accordance with §2.948(a)(3), a complete site description is contained at MET Laboratories.

D. Description of Test Sample

The Firetide, Inc. 7200 Outdoor Unit, is a Dual Radio Wireless Mesh Node.



Photograph 1. Firetide, Inc. 7200 Outdoor Unit

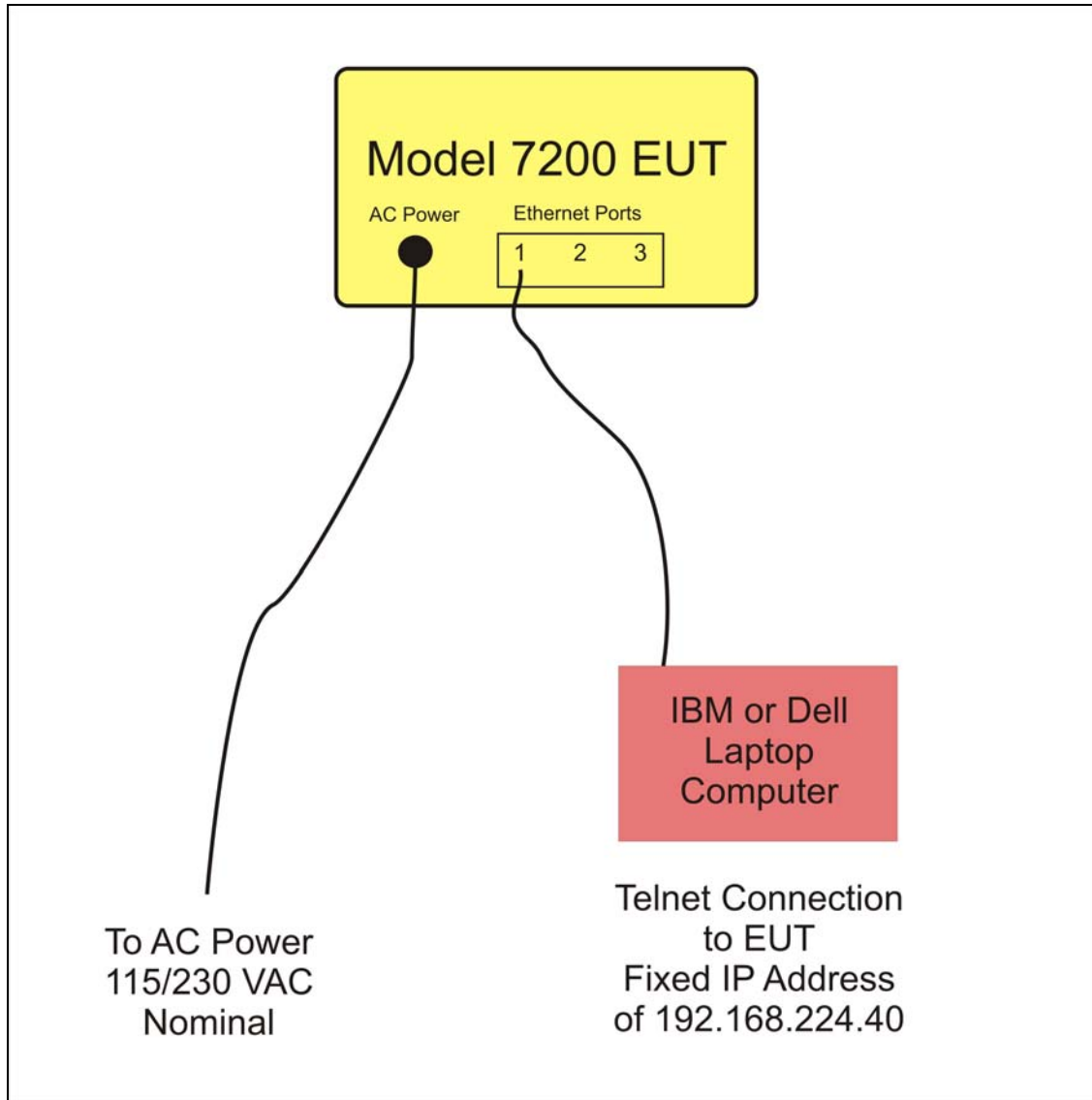

Figure 1. Block Diagram of Test Configuration

E. Equipment Configuration

The EUT was set up as outlined in Figure 1, Block Diagram of Test Setup. All cards, racks, etc., incorporated as part of the EUT is included in the following list.

Ref. ID	Slot #	Name / Description	Model Number	Part Number	Serial Number	Rev. #
N/A	N/A	HOTPORT INDOOR MESH NODE	7200	7200	N/A	1

Table 4. Equipment Configuration

F. Support Equipment

Firetide, Inc. supplied support equipment necessary for the operation and testing of the 7200 Outdoor Unit. All support equipment supplied is listed in the following Support Equipment List.

Ref. ID	Name / Description	Manufacturer	Model Number
N/A	LAPTOP COMPUTER	IBM	T42
N/A	LAPTOP COMPUTER	DELL	S300

Table 5. Support Equipment

G. Ports and Cabling Information

Ref. ID	Port name on EUT	Cable Description or reason for no cable	Qty.	Length (m)	Shielded (Y/N)	Termination Box ID & Port Name
N/A	PORT 1	ETHERNET	1	18	N	LAPTOP
N/A	PORT 2 – 3	NOT CONNECTED; ONLY 1 ETHERNET CONNECTION IS NECESSARY TO COMMUNICATE WITH EUT	N/A	N/A	N/A	N/A
N/A	AC POWER	3 PIN CIRCULAR CONNECTOR	1	5	N	N/A
N/A	USB	NOT USED; DISABLED	N/A	N/A	N/A	N/A

Table 6. Ports and Cabling Information

H. Mode of Operation

The EUT has the Atheros Radio Test (ART) software loaded. The EUT can be put into continuous TX or RX using ART. The Mesh Node has a default IP address of 192.168.224.150. An external computer can ping this address to verify the Ethernet PHY and processor are running.

I. Method of Monitoring EUT Operation

An external computer can ping this address to verify the Ethernet PHY and processor are running.

J. Modifications

a) Modifications to EUT

7200 Outdoor unit did not pass conducted line emission (15.207) testing. It was determined that additional common mode filtering was necessary on the line and neutral AC power input. In addition, improper trace routing caused arcing between the AC input and ground. The ground plane was removed in the vicinity of the common mode filtering and power pins.

The following was used to resolve this:

Added 100 uH SMT inductor between pin 1 of J7 and node formed by C5, D3, and D4.

Added 100 uH SMT inductor between pin 2 of F1 and node formed by C6, D3, and D4.

b) Modifications to Test Standard

No modifications were made to the test standard.

K. Disposition of EUT

The test sample including all support equipment submitted to the Electro-Magnetic Compatibility Lab for testing was returned to Firetide, Inc. upon completion of testing.

III. Electromagnetic Compatibility Criteria for Unintentional Radiators

Electromagnetic Compatibility Criteria

§ 15.107 Conducted Emissions Limits

Test Requirement(s): **15.107 (a)** Except for Class A digital devices, for equipment that is designed to be connected to the public utility (AC) power line, the radio frequency voltage that is conducted back onto the AC power line on any frequency or frequencies within the band 150 kHz to 30 MHz shall not exceed the limits in Table 7. Compliance with this provision shall be based on the measurement of the radio frequency voltage between each power line and ground at the power terminals.

15.107 (b) For a Class A digital device that is designed to be connected to the public utility (AC) power line, the radio frequency voltage that is conducted back onto the AC power line on any frequency or frequencies within the band 150 kHz to 30 MHz shall not exceed the limits in Table 7. Compliance with this provision shall be based on the measurement of the radio frequency voltage between each power line and ground at the power terminals. The lower limit applies at the band edges.

Frequency range (MHz)	Class A Conducted Limits (dB μ V)		*Class B Conducted Limits (dB μ V)	
	Quasi-Peak	Average	Quasi-Peak	Average
* 0.15- 0.45	79	66	66 - 56	56 - 46
0.45 - 0.5	79	66	56	46
0.5 - 30	73	60	60	50

Note 1 — The lower limit shall apply at the transition frequencies.

Note 2 — The limit decreases linearly with the logarithm if the frequency in the range 0.15 MHz to 0.5 MHz.

* -- Limits per Subsection 15.207(a).

Table 7. Conducted Limits for Radio Frequency Devices calculated from FCC Part 15 Subsections 15.107(a) (b) and 15.207(a)

Test Results: The EUT was found compliant with the Class B requirement(s) of this section. Measured emissions were below applicable limits.

Test Engineer(s): Minh Ly

Test Date(s): 08/06/09

Conducted Emissions - Voltage, AC Power

Line	Freq (MHz)	QP Amplitude	QP Limit	Delta	Pass	Average Amplitude	Average Limit	Delta	Pass
Line	0.207	36.87	63.332	-26.462	Pass	32.02	53.332	-21.312	Pass
Line	9.56	36.79	60	-23.21	Pass	30.65	50	-19.35	Pass
Line	23.14	20.97	60	-39.03	Pass	15.998	50	-34.002	Pass
Neutral	0.207	34.76	63.332	-28.572	Pass	31.85	53.332	-21.482	Pass
Neutral	0.414	32.71	57.591	-24.881	Pass	31.52	47.591	-16.071	Pass
Neutral	9.562	37.77	60	-22.23	Pass	30.47	50	-19.53	Pass

Table 8. Conducted Emissions - Voltage, AC Power, Test Results

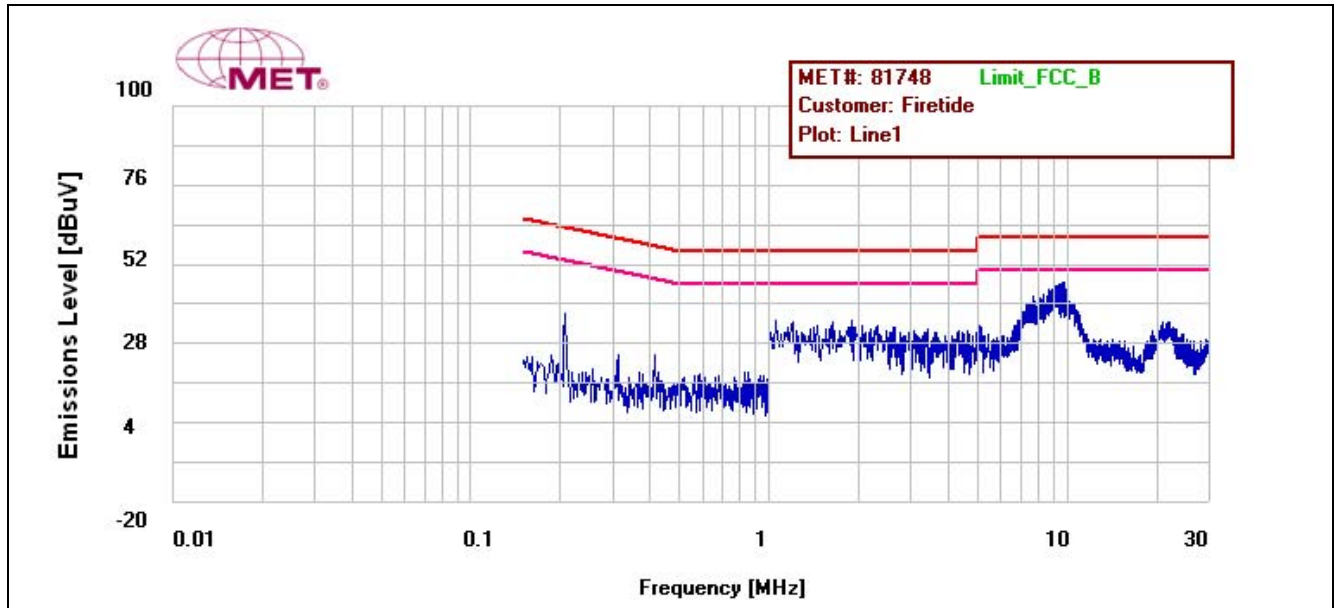

Plot 1. Conducted Emission, Phase Line Plot

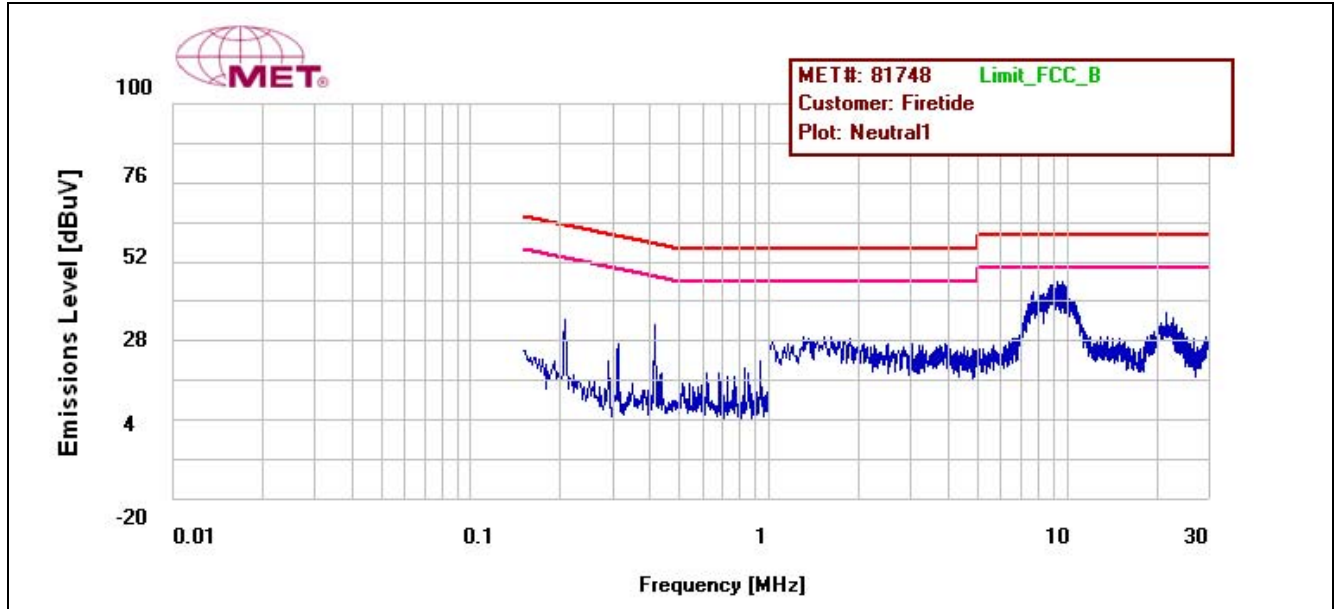

Plot 2. Conducted Emission, Neutral Line Plot

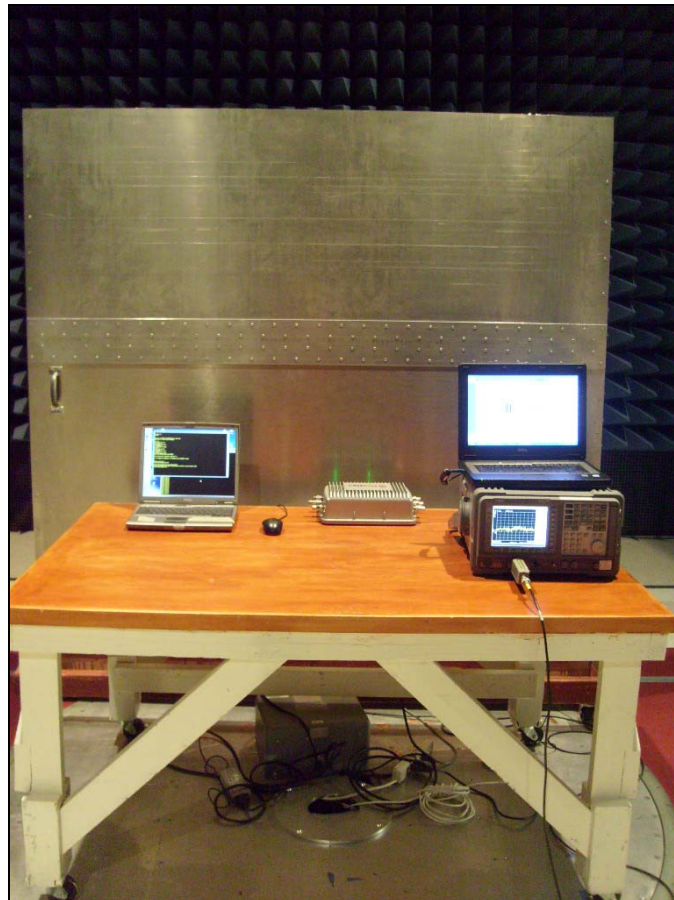

Photograph 2. Conducted Emissions, Test Setup

Radiated Emission Limits

§ 15.109 Radiated Emissions Limits

Test Requirement(s): **15.109 (a)** Except for Class A digital devices, the field strength of radiated emissions from unintentional radiators at a distance of 3 meters shall not exceed the Class B limits expressed in Table 9.

15.109 (b) The field strength of radiated emissions from a Class A digital device, as determined at a distance of 10 meters, shall not exceed the Class A limits expressed in Table 9.

Frequency (MHz)	Field Strength (dB μ V/m)	
	§15.109 (b), Class A Limit (dB μ V) @ 10m	§15.109 (a), Class B Limit (dB μ V) @ 3m
30 - 88	39.00	40.00
88 - 216	43.50	43.50
216 - 960	46.40	46.00
Above 960	49.50	54.00

Table 9. Radiated Emissions Limits calculated from FCC Part 15, §15.109 (a) (b)

Test Procedures: The EUT was placed on a 0.8m-high wooden table inside a semi-anechoic chamber. The method of testing and test conditions of ANSI C63.4 were used. An antenna was located 3 m from the EUT on an adjustable mast. A pre-scan was first performed in order to find prominent radiated emissions. For final emissions measurements at each frequency of interest, the EUT was rotated and the antenna height was varied between 1 m and 4 m in order to maximize the emission. Measurements in both horizontal and vertical polarities were made and the data was recorded. Unless otherwise specified, measurements were made using a quasi-peak detector with a 120 kHz bandwidth.

Test Results: The EUT was found to comply with the Class A requirement(s) of this section. Measured emissions were below applicable limits.

Test Engineer(s): Minh Ly

Test Date(s): 08/10/09

Radiated Emissions Limits Test Results, Class A

Frequency (MHz)	Antenna Polarity	EUT Azimuth (Degrees)	Antenna Height (cm)	Uncorrected Amplitude (dBuV)	ACF (dB/m)	Pre Amp Gain (dB)	CBL (dB)	DCF (dB)	Corrected Amplitude (dBuV/m)	Limit (dBuV/m)	Margin (dB)
45.84	V	278	100	26.74	9.164	0	1.644	-10.46	27.088	39	-11.912
100	V	0	100	20.3	12.7	0	2.47	-10.46	25.01	43.5	-18.49
100	H	237	190	21.32	11.1	0	2.47	-10.46	24.43	43.5	-19.07
157.52	H	106	202	29.59	10.898	0	3.178	-10.46	33.206	43.5	-10.294
157.6	V	213	100	28.96	11.292	0	3.178	-10.46	32.97	43.5	-10.53
332.48	H	206	109	20.96	14.75	0	4.64	-10.46	29.89	46.4	-16.51

Table 10. Radiated Emissions, Test Results, FCC Limits, 30 MHz – 1 GHz

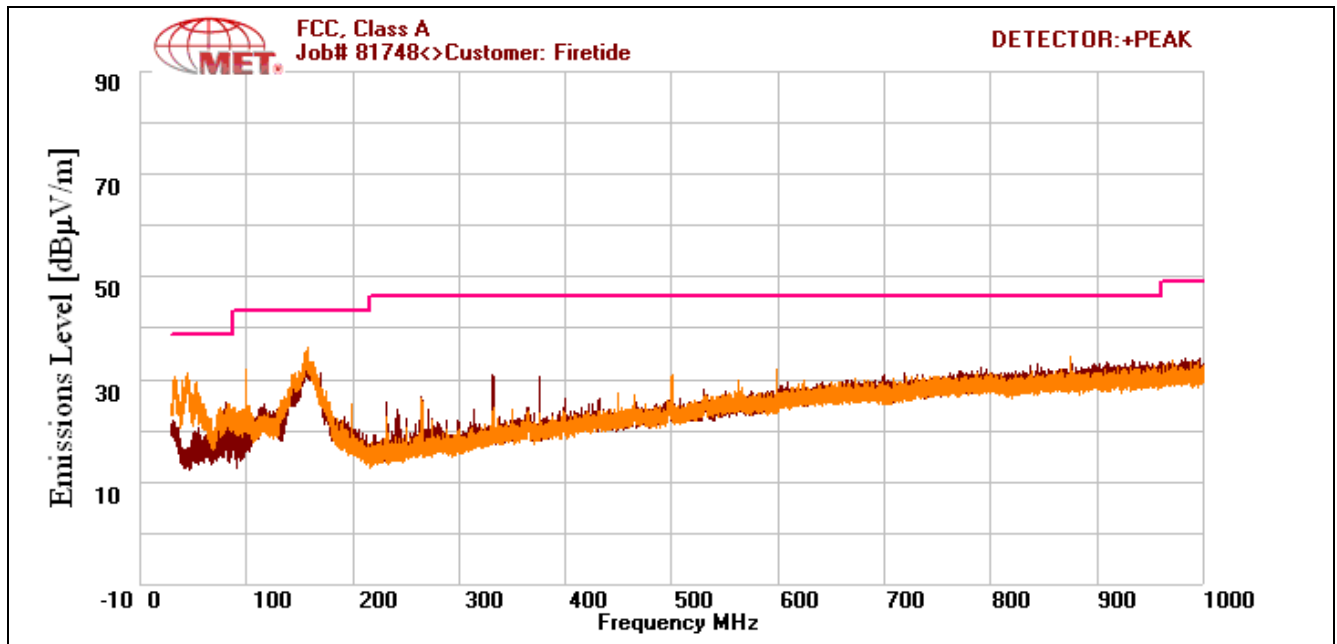

Plot 3. Radiated Emissions, Pre-Scan, FCC Limits, 30 MHz – 1 GHz

Frequency (MHz)	Antenna Polarity	EUT Azimuth (Degrees)	Antenna Height (cm)	Uncorrected Amplitude (dBuV)	ACF (dB/m)	Pre Amp Gain (dB)	CBL (dB)	DCF (dB)	Corrected Amplitude (dBuV/m)	Limit (dBuV/m)	Margin (dB)
1332	V	360	100	54.58	-1.641	35.149	1.726	-10.46	9.056	49.5	-40.444
1500	V	326	100	52.75	-1.848	34.894	1.82	-10.46	7.368	49.5	-42.132
4000	H	125	100	46.9	3.795	34.456	3.35	-10.46	9.129	49.5	-40.371
6000	V	0	100	44.09	8.972	34.372	4.61	-10.46	12.84	49.5	-36.66
6000	H	0	100	43.72	8.972	34.372	4.61	-10.46	12.47	49.5	-37.03

Table 11. Radiated Emissions, Test Results, FCC Limits, 1GHz – 6GHz

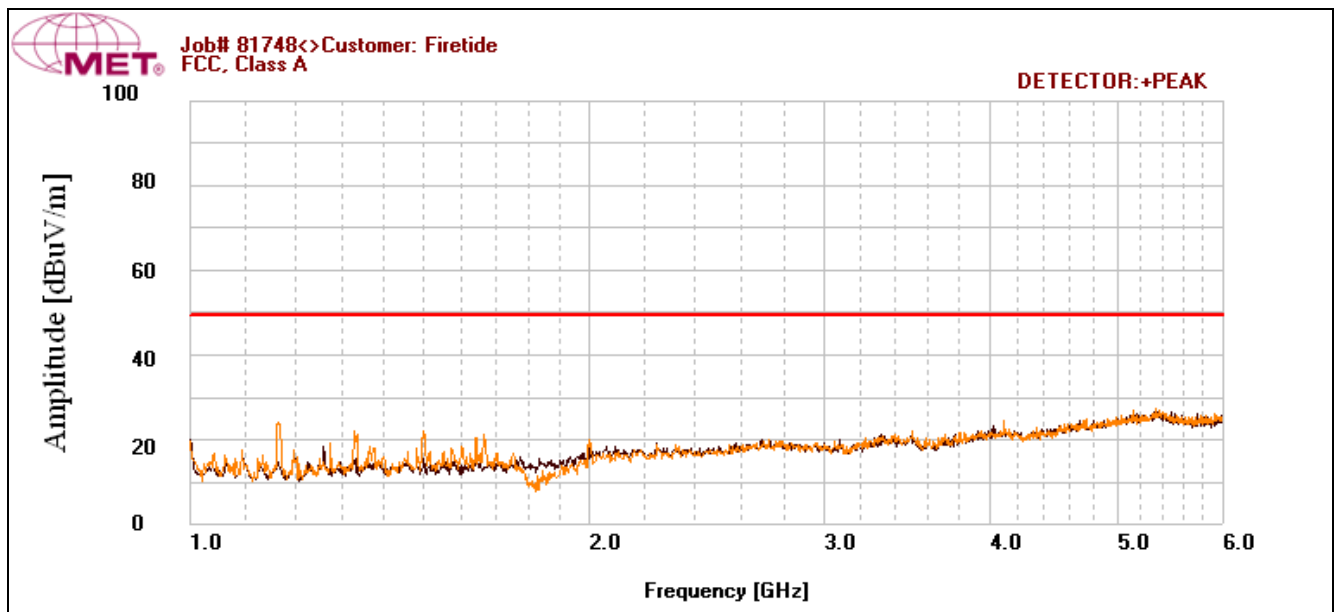

Plot 4. Radiated Emissions, Pre-Scan, FCC Limits, 1 GHz – 6 GHz

Frequency (MHz)	Antenna Polarity	EUT Azimuth (Degrees)	Antenna Height (cm)	Uncorrected Amplitude (dBuV)	ACF (dB/m)	Pre Amp Gain (dB)	CBL (dB)	DCF (dB)	Corrected Amplitude (dBuV/m)	Limit (dBuV/m)	Margin (dB)
45.84	V	278	100	26.74	9.164	0	1.644	-10.46	27.088	40	-12.912
100	V	0	100	20.3	12.7	0	2.47	-10.46	25.01	40	-14.99
157.6	V	213	100	28.96	11.292	0	3.178	-10.46	32.97	40	-7.03
100	H	237	190	21.32	11.1	0	2.47	-10.46	24.43	40	-15.57
157.52	H	106	202	29.59	10.898	0	3.178	-10.46	33.206	40	-6.794
332.48	H	206	109	20.96	14.75	0	4.64	-10.46	29.89	47	-17.11

Table 12. Radiated Emissions, Test Results, ICES-003 Limits, 30 MHz – 1 GHz

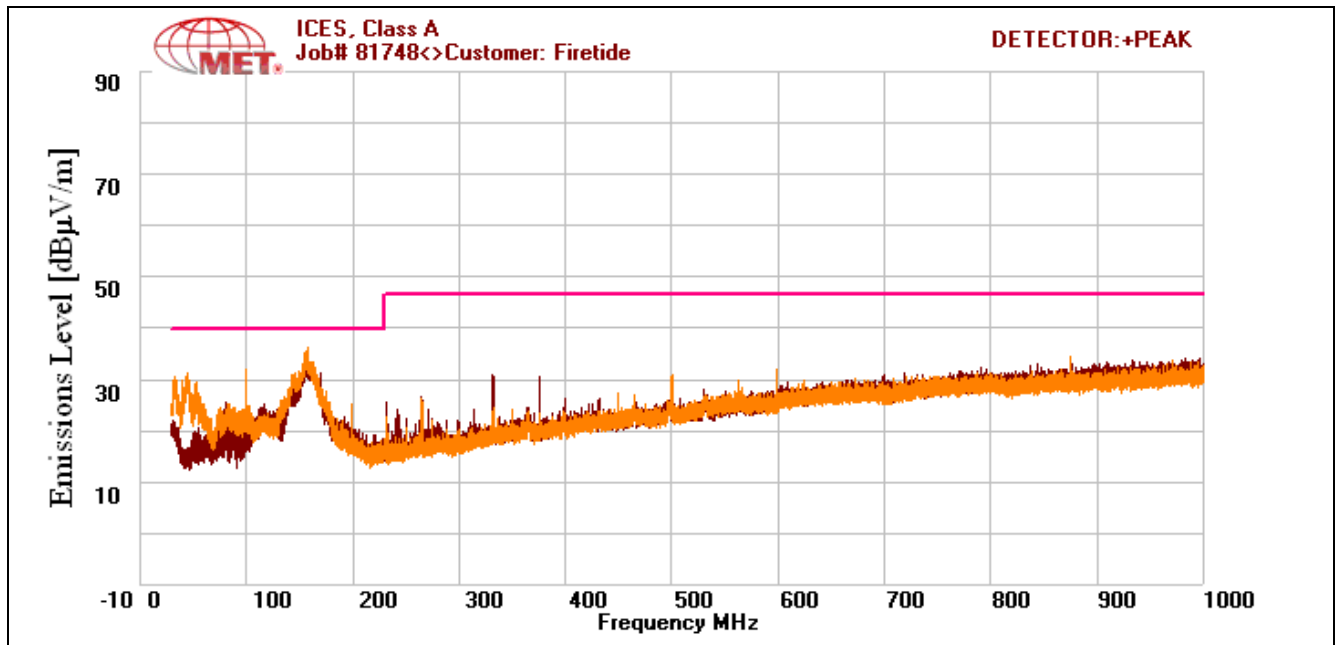

Plot 5. Radiated Emissions, Pre-Scan, ICES-003 Limits, 30 MHz – 1 GHz

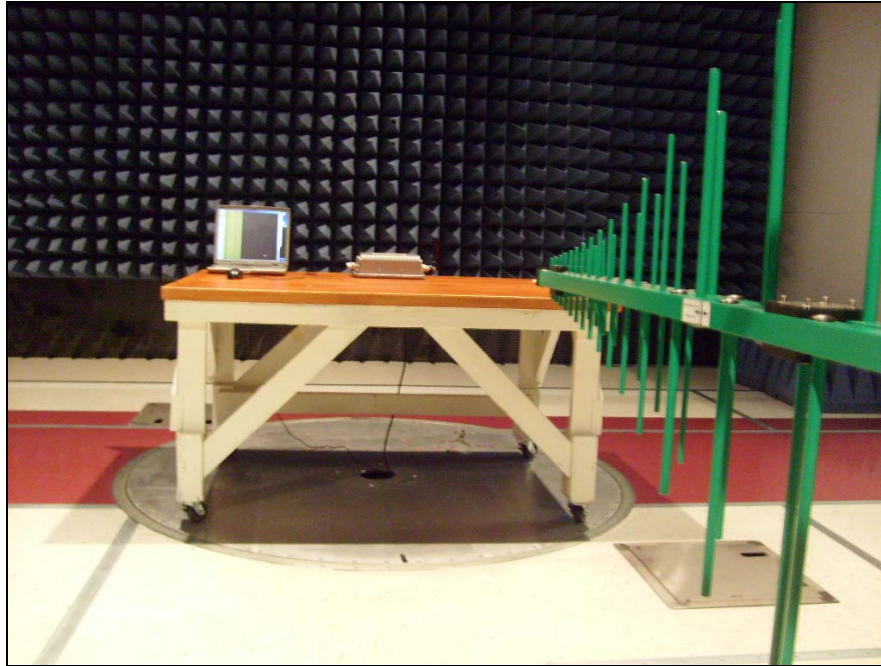

Photograph 3 Radiated Emission Test Setup 30 MHz – 1 GHz

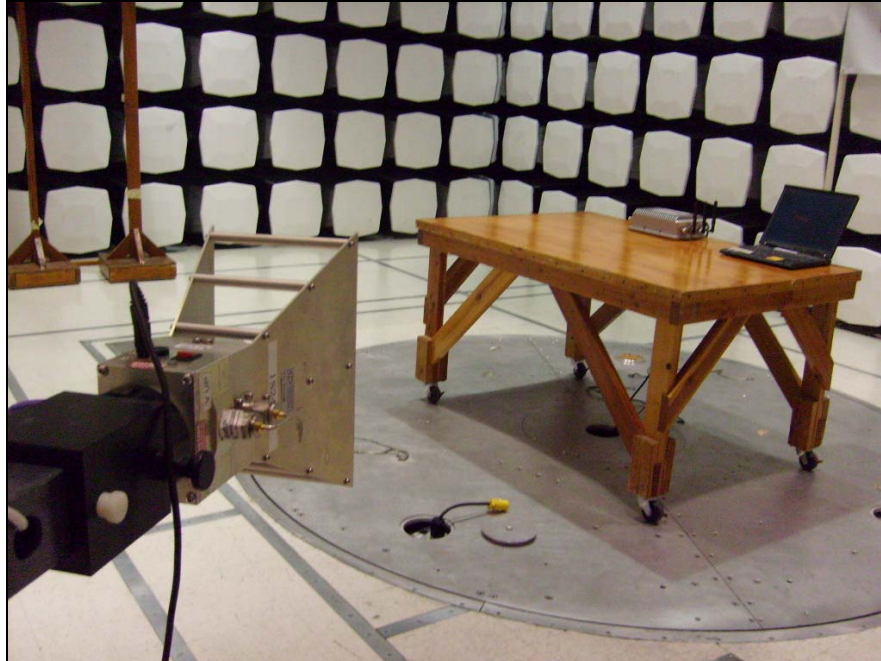

Photograph 4. Radiated Emission Test Setup 1 GHz – 6 GHz

IV. Electromagnetic Compatibility Criteria for Intentional Radiators

Electromagnetic Compatibility Criteria for Intentional Radiators

§ 15.203 Antenna Requirement

Test Requirement: § 15.203: An intentional radiator shall be designed to ensure that no antenna other than that furnished by the responsible party shall be used with the device. The use of a permanently attached antenna or of an antenna that uses a unique coupling to the intentional radiator shall be considered sufficient to comply with the provisions of this section. The manufacturer may design the unit so that a broken antenna can be replaced by the user, but the use of a standard antenna jack or electrical connector is prohibited.

The structure and application of the EUT were analyzed to determine compliance with Section 15.203 of the Rules. Section 15.203 states that the subject device must meet at least one of the following criteria:

- a.) Antenna must be permanently attached to the unit.
- b.) Antenna must use a unique type of connector to attach to the EUT.
- c.) Unit must be professionally installed. Installer shall be responsible for verifying that the correct antenna is employed with the unit.

Results: The EUT as tested is compliant the criteria of §15.203. The unit will be professionally installed.

Gain/Type	Model	Manufacturer
5dBi Omni (5GHz)	C812-510012-A	Wha Yu
9dBi Omni	MA-W055-MIMONHFT9	MARS ANTENNAS & RF Systems LTD
16dBi Sector	MA-WD55-MIMOFT16	MARS ANTENNAS & RF Systems LTD
19dBi Panel	MA-WA55-MIMO	MARS ANTENNAS & RF Systems LTD

Table 13. Antenna Information

Test Engineer(s): Anderson Soungpanya

Test Date(s): 12/17/09

Electromagnetic Compatibility Criteria for Intentional Radiators

§ 15.207 Conducted Emissions Limits

Test Requirement(s): § 15.207 (a): For an intentional radiator that is designed to be connected to the public utility (AC) power line, the radio frequency voltage that is conducted back onto the AC power line on any frequency or frequencies, within the band 150 kHz to 30MHz, shall not exceed the limits in the following table, as measured using a 50 μ H/50 Ω line impedance stabilization network (LISN). Compliance with the provisions of this paragraph shall be based on the measurement of the radio frequency voltage between each power line and ground at the power terminal. The lower limit applies at the boundary between the frequency ranges.

Frequency range (MHz)	§ 15.207(a), Conducted Limit (dB μ V)	
	Quasi-Peak	Average
* 0.15- 0.45	66 - 56	56 - 46
0.45 - 0.5	56	46
0.5 - 30	60	50

Table 14. Conducted Limits for Intentional Radiators from FCC Part 15 § 15.207(a)

Test Procedure: The EUT was placed on a 0.8 m-high wooden table inside a semi-anechoic chamber. The EUT was situated such that the back of the EUT was 0.4 m from one wall of the vertical ground plane, and the remaining sides of the EUT were no closer than 0.8 m from any other conductive surface. The EUT was powered from a 50 Ω /50 μ H Line Impedance Stabilization Network (LISN). The EMC receiver scanned the frequency range from 150 kHz to 30 MHz. Conducted Emissions measurements were made in accordance with ANSI C63.4-1992 "Methods and Measurements of Radio-Noise Emissions from Low-Voltage Electrical and Electronic Equipment in the Range of 9kHz to 40 GHz". The measurements were performed over the frequency range of 0.15 MHz to 30 MHz using a 50 Ω /50 μ H LISN as the input transducer to an EMC/field intensity meter.

Test Results: The EUT was found to comply with the requirement(s) of this section. Measured emissions were below applicable limits.

Test Engineer(s): Minh Ly

Test Date(s): 08/17/09

Conducted Emissions - Voltage, AC Power

Line	Freq (MHz)	QP Amplitude	QP Limit	Delta	Pass	Average Amplitude	Average Limit	Delta	Pass
Line	0.206	38.73	63.372	-24.642	Pass	33.83	53.372	-19.542	Pass
Line	0.76	21.03	56	-34.97	Pass	16.023	46	-29.977	Pass
Line	9.45	37.95	60	-22.05	Pass	31.47	50	-18.53	Pass
Neutral	0.207	36.5	63.332	-26.832	Pass	33.9	53.332	-19.432	Pass
Neutral	0.414	33.77	57.591	-23.821	Pass	32.7	47.591	-14.891	Pass
Neutral	9.117	38.87	60	-21.13	Pass	32.33	50	-17.67	Pass

Table 15. Conducted Emissions - Voltage, AC Power, Test Results

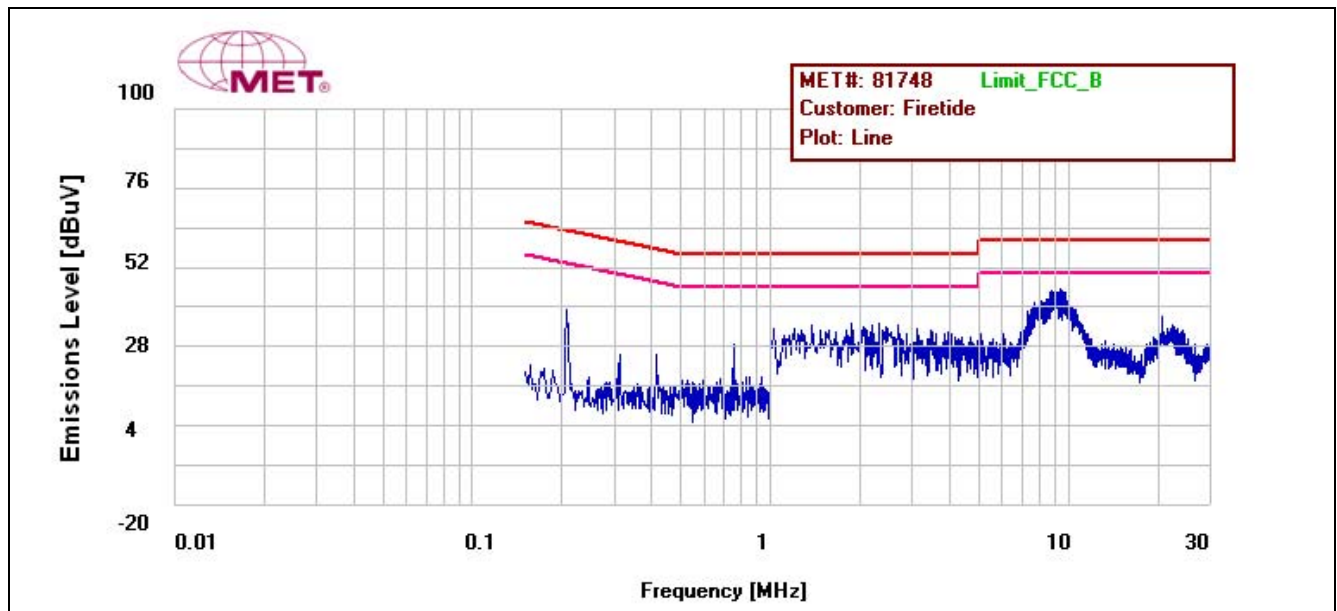

Plot 6. §15.207 Conducted Emissions, Phase Line Plot, 7200 Outdoor Unit

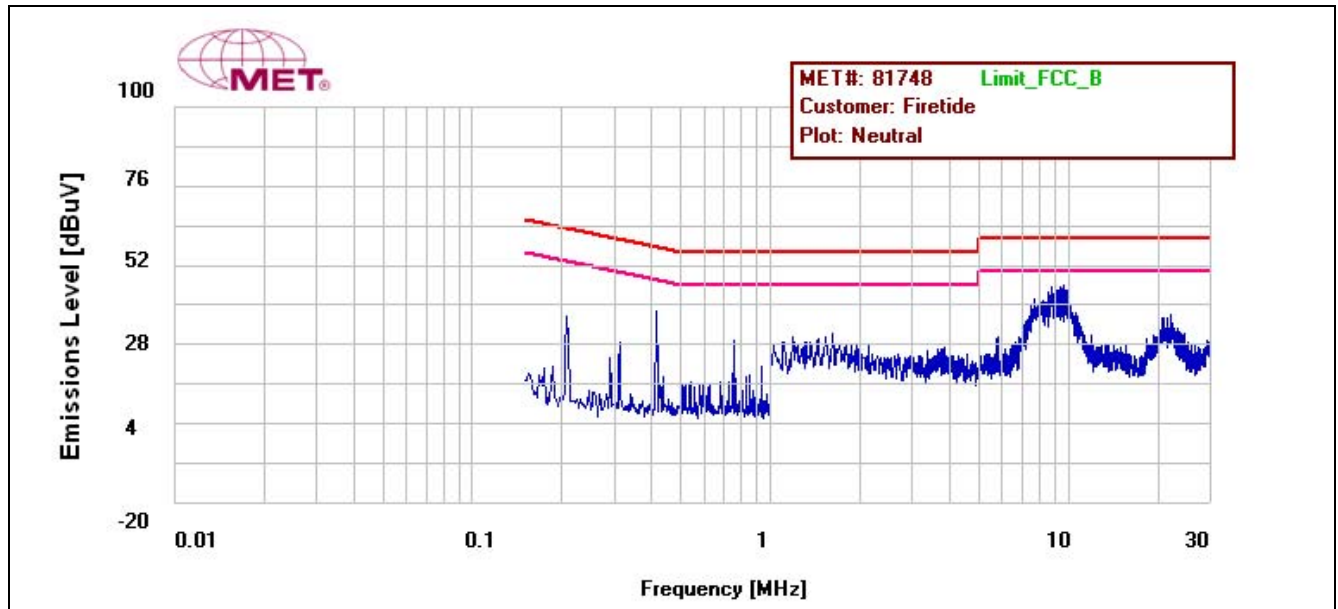

Plot 7. §15.207 Conducted Emissions, Neutral Line Plot, 7200 Outdoor Unit



Photograph 5. Conducted Emissions, Test Setup

Electromagnetic Compatibility Criteria for Intentional Radiators

§ 15.403(c) 26dB Bandwidth

- Test Requirements:** § 15.403 (c): Operation under the provisions of this section is limited to frequency hopping and digitally modulated intentional radiators that comply with the following provisions:
- Test Procedure:** The transmitter was set to the mid channel at the highest output power and connected to the spectrum analyzer through an attenuator. The bandwidth of the fundamental frequency was measured with the spectrum analyzer using a RBW approximately equal to 1% of the total emission bandwidth, $VBW > RBW$. The 26 dB Bandwidth was measured and recorded. The measurements were repeated at the low, mid and high channels.
- Test Results** Equipment complies with § 15.407 (c). The 26 dB Bandwidth was determined from the plots on the following pages.
- Test Engineer(s):** Anderson Soungpanya
- Test Date(s):** 12/17/09

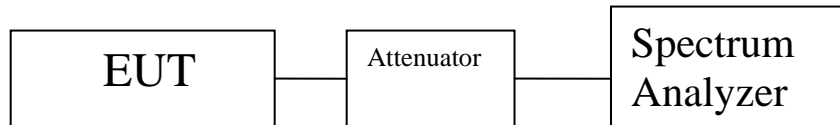

Figure 2. Occupied Bandwidth Test Setup

Occupied Bandwidth, Port 1				
Mode	Frequency (MHz)		Measured 26 dB Bandwidth (MHz)	99 % Bandwidth (MHz)
802.11a	U-NII-3	5745	18.54	16.50
		5785	19.14	16.38
		5805	21.37	16.42
802.11n 20MHz	U-NII-3	5745	20.25	17.63
		5785	19.96	17.56
		5805	19.74	27.62
802.11n 40MHz	U-NII-3	5755	40.94	36.38
		5795	41.03	36.57

Table 16. Occupied Bandwidth, Port 1, Test Results

Occupied Bandwidth, Port 2				
Mode	Frequency (MHz)		Measured 26 dB Bandwidth (MHz)	99 % Bandwidth (MHz)
802.11n 20MHz	U-NII-3	5745	19.41	17.55
		5785	19.61	17.48
		5805	20.32	17.69
802.11n 40MHz	U-NII-3	5755	41.37	36.68
		5795	41.30	36.25

Table 17. Occupied Bandwidth, Port 2, Test Results

Occupied Bandwidth, Port 3				
Mode	Frequency (MHz)		Measured 26 dB Bandwidth (MHz)	99 % Bandwidth (MHz)
802.11n 20MHz	U-NII-3	5745	19.65	17.55
		5785	19.72	17.58
		5805	23.78	17.61
802.11n 40MHz	U-NII-3	5755	41.94	36.50
		5795	41.05	36.54

Table 18. Occupied Bandwidth, Port 3, Test Results

Occupied Bandwidth, Port 1

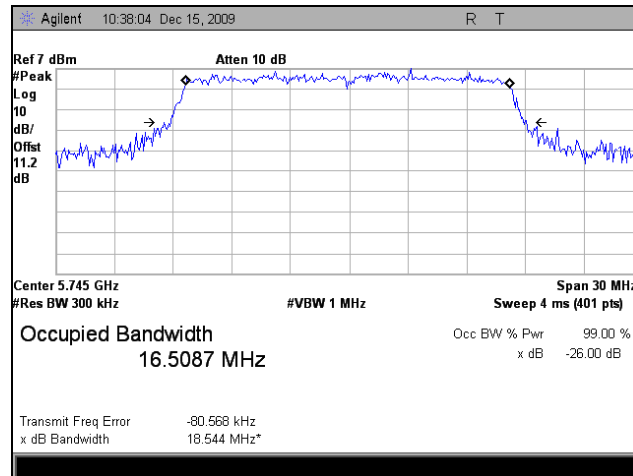

Plot 8. Occupied Bandwidth, Port 1, 802.11a, 5745 MHz

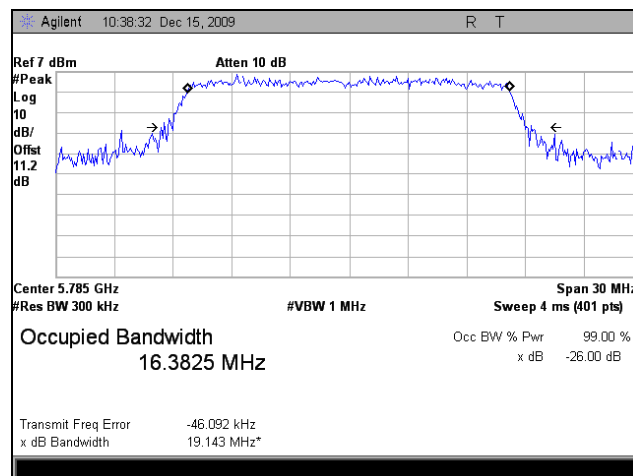

Plot 9. Occupied Bandwidth, Port 1, 802.11a, 5785 MHz

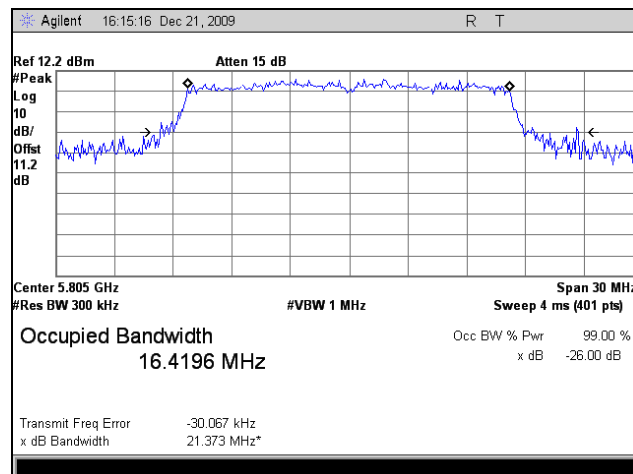

Plot 10. Occupied Bandwidth, Port 1, 802.11a, 5805 MHz

Occupied Bandwidth, Port 1, 802.11n 20MHz

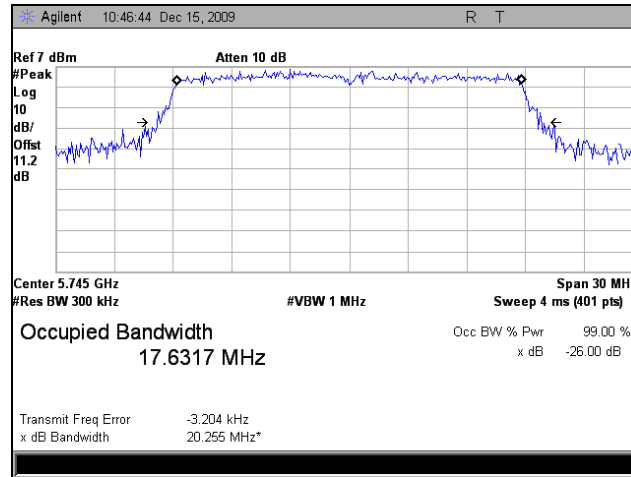

Plot 11. Occupied Bandwidth, Port 1, 802.11n 20MHz, 5745 MHz

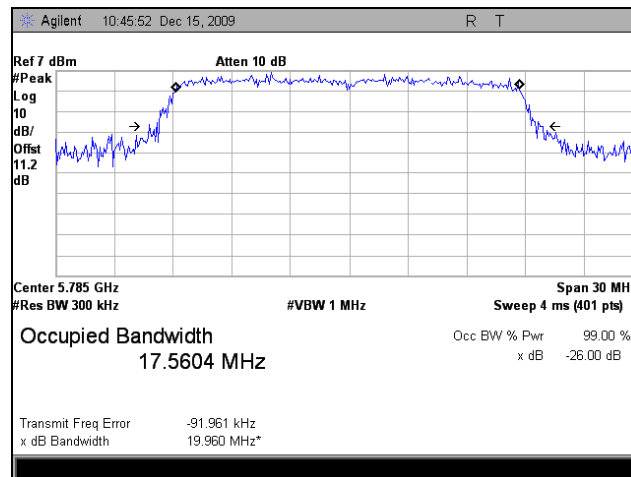

Plot 12. Occupied Bandwidth, Port 1, 802.11n 20MHz, 5785 MHz

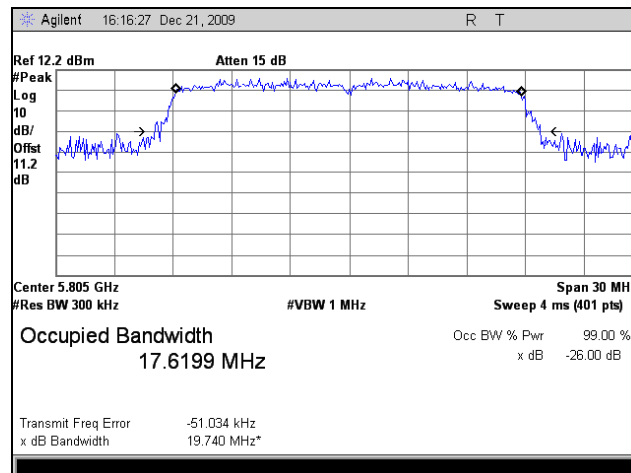

Plot 13. Occupied Bandwidth, Port 1, 802.11n 20MHz, 5805 MHz

Occupied Bandwidth, Port 1, 802.11n 40MHz

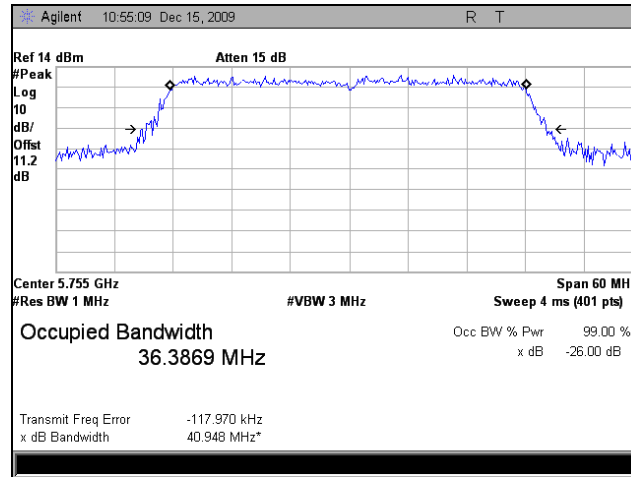

Plot 14. Occupied Bandwidth, Port 1, 802.11n 40MHz, 5755 MHz

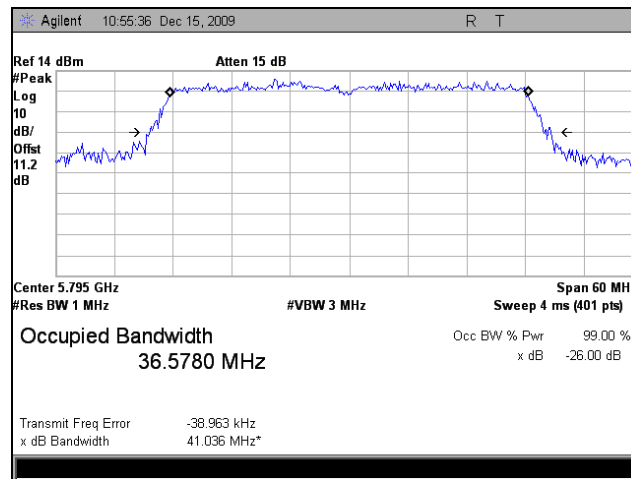

Plot 15. Occupied Bandwidth, Port 1, 802.11n 40MHz, 5795 MHz

Occupied Bandwidth, Port 2, 802.11n 20MHz

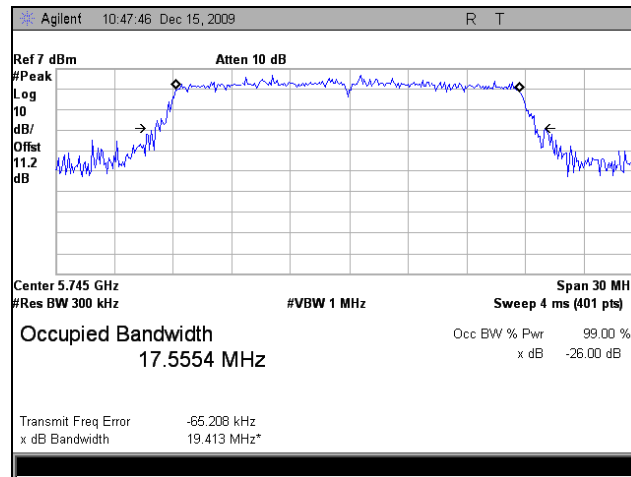

Plot 16. Occupied Bandwidth, Port 2, 802.11n 20MHz, 5745 MHz

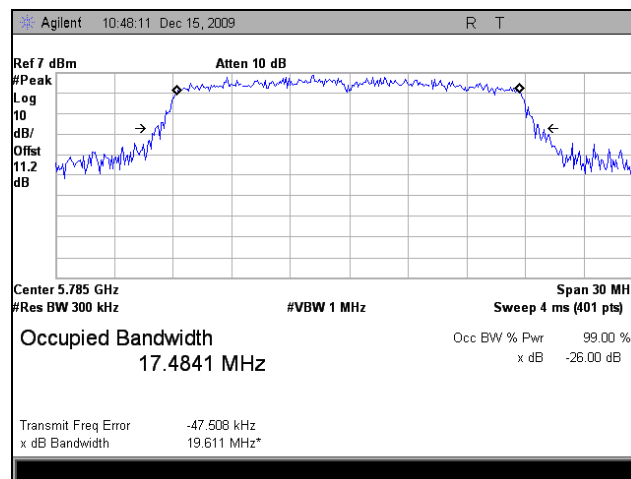

Plot 17. Occupied Bandwidth, Port 2, 802.11n 20MHz, 5785 MHz

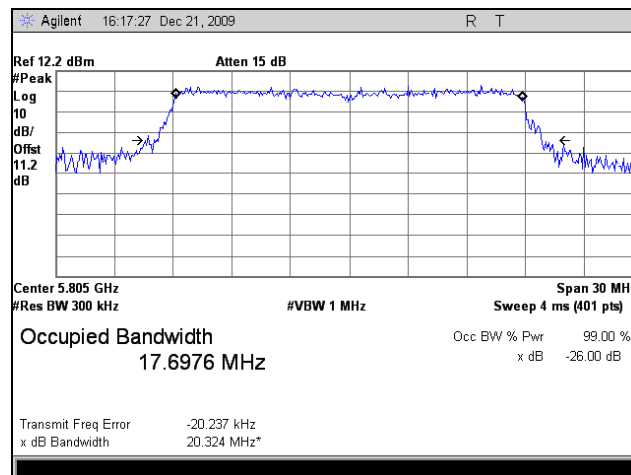

Plot 18. Occupied Bandwidth, Port 2, 802.11n 20MHz, 5805 MHz

Occupied Bandwidth, Port 2, 802.11n 40MHz

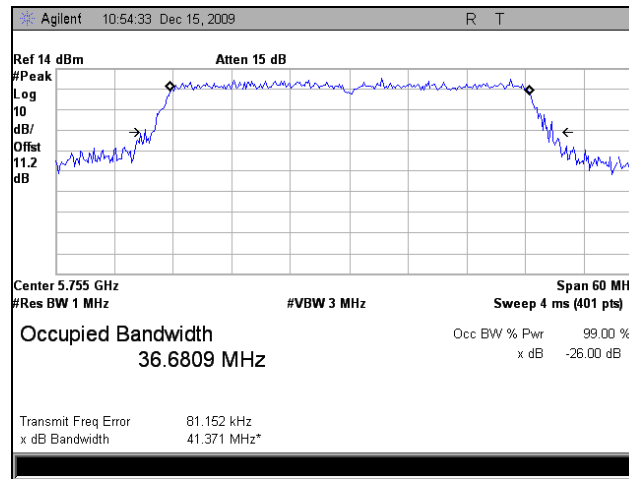

Plot 19. Occupied Bandwidth, Port 2, 802.11n 40MHz, 5755 MHz

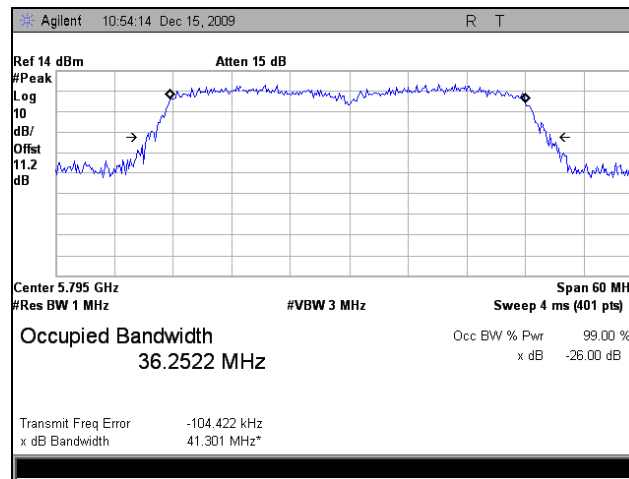

Plot 20. Occupied Bandwidth, Port 2, 802.11n 40MHz, 5795 MHz

Occupied Bandwidth, Port 3, 802.11n 20MHz

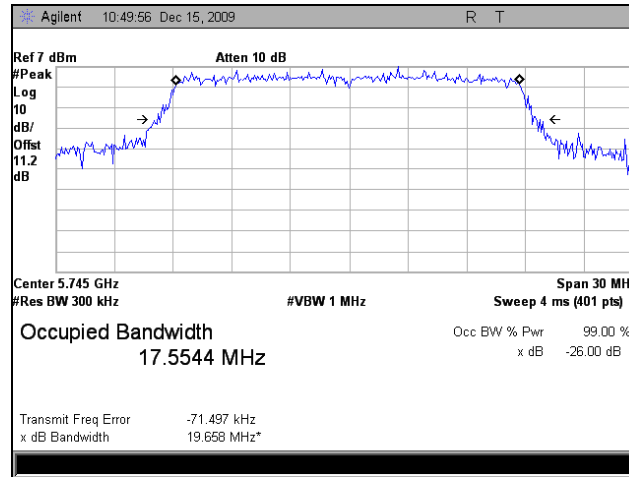

Plot 21. Occupied Bandwidth, Port 3, 802.11n 20MHz, 5745 MHz

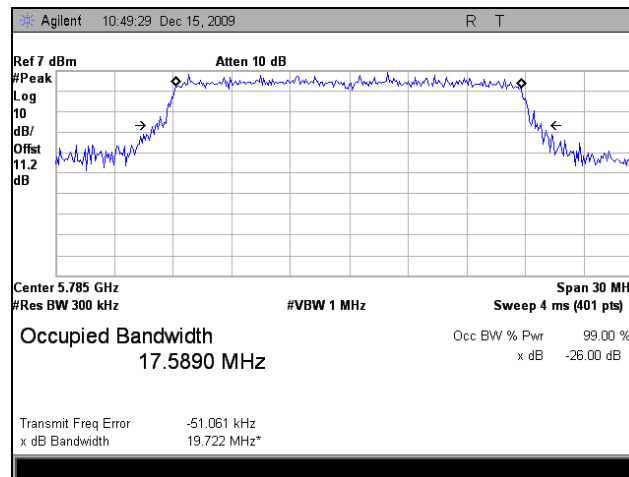

Plot 22. Occupied Bandwidth, Port 3, 802.11n 20MHz, 5785 MHz

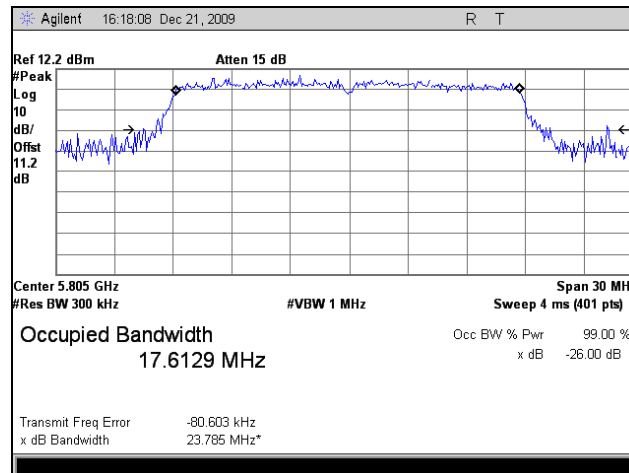

Plot 23. Occupied Bandwidth, Port 3, 802.11n 20MHz, 5805 MHz

Occupied Bandwidth, Port 3, 802.11n 40MHz

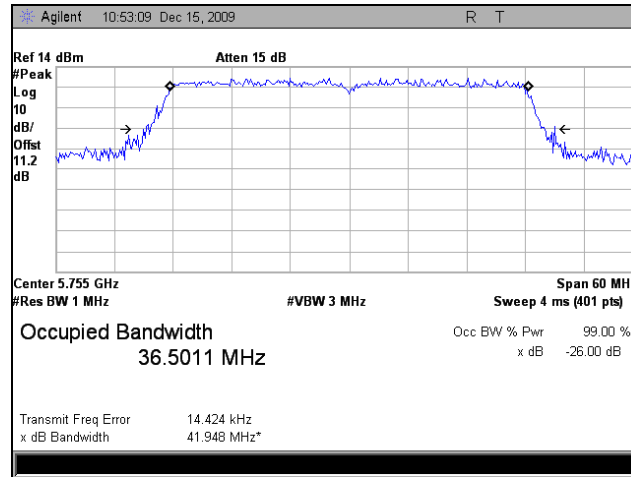

Plot 24. Occupied Bandwidth, Port 3, 802.11n 40MHz, 5755 MHz

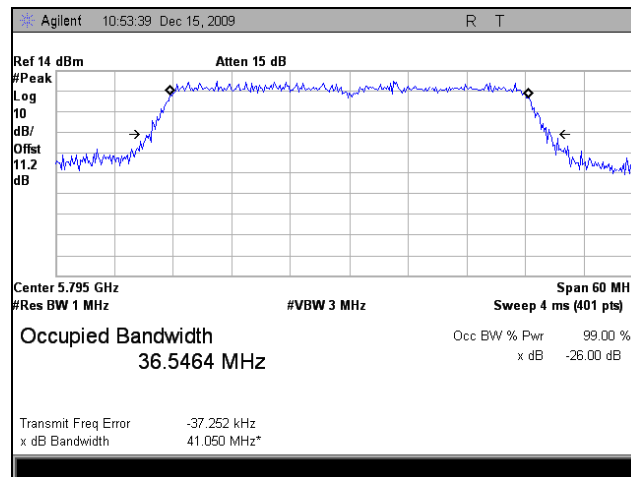

Plot 25. Occupied Bandwidth, Port 3, 802.11n 40MHz, 5795 MHz

Electromagnetic Compatibility Criteria for Intentional Radiators

§ 15.407(a) (1), (2) RF Power Output

Test Requirements: §15.407(a) (1), (2): The maximum output power of the intentional radiator shall not exceed the following:

Digital Transmission Systems (MHz)	Output Limit (mW)
5150-5250	50
5250-5350	250
5470-5725	250
5725-5825	1000

Table 19. Output Power Requirements from §15.407

§15.407(a) (1): For the band 5.15-5.25 GHz the peak transmit power over the frequency band of operation shall not exceed the lesser 50mW or $4\text{dBm} + 10\log B$, where B is the 26-dB emission bandwidth in MHz.

§15.407(a) (2): For the band 5.25-5.35GHz & 5.470-5.72GHz the peak transmit power over the frequency band of operation shall not exceed the lesser of 250mW or $11\text{dBm} + 10\log B$, where B is the 26-dB emission bandwidth in MHz.

§15.407(a) (3): For the band 5.725 – 5.825 GHz the peak transmit power over the frequency band of operation shall not exceed the lesser 1W or $17\text{dBm} + 10\log B$, where B is the 26-dB emission bandwidth in MHz.

Test Procedure: The transmitter was connected to a calibrated Spectrum analyzer. The EUT was measured at the low, mid and high channels of each band with the data rate that produced the highest output power.

Test Results: Equipment complies with the Peak Power Output limits of § 15.401(a) (3).

Test Engineer(s): Anderson Soungpanya

Test Date(s): 12/17/09

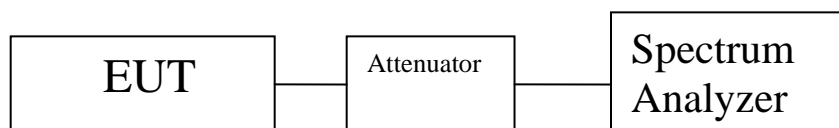

Figure 3. Peak Power Output Test Setup

RF POWER OUTPUT, Port 1			
Mode	Frequency (MHz)		Measured Output Power (dBm)
802.11a	U-NII-3	5745	17.24
		5785	16.87
		5805	15.93
802.11n 20MHz	U-NII-3	5745	17.24
		5785	17.19
		5805	17.87
802.11n 40MHz	U-NII-3	5755	17.90
		5795	17.82

Table 20. RF Power Output, Test Results, Port 1

RF POWER OUTPUT, Port 2			
Mode	Frequency (MHz)		Measured Output Power (dBm)
802.11n 20MHz	U-NII-3	5745	15.49
		5785	16.67
		5805	14.80
802.11n 40MHz	U-NII-3	5755	18.14
		5795	17.50

Table 21. RF Power Output, Test Results, Port 2

RF POWER OUTPUT, Port 3			
Mode	Frequency (MHz)		Measured Output Power (dBm)
802.11n 20MHz	U-NII-3	5745	17.24
		5785	17.40
		5805	15.15
802.11n 40MHz	U-NII-3	5755	17.99
		5795	17.51

Table 22. RF Power Output, Test Results, Port 3

RF POWER OUTPUT, Summed Power						
Mode	Frequency (MHz)	Port 1	Port 2	Port 3	Summed Power (dBm)	
802.11n 20MHz	U-NII-3	5745	17.24	15.49	17.24	21.50
		5785	17.19	16.67	17.40	21.86
		5805	17.87	14.80	15.15	20.94
802.11n 40MHz	U-NII-3	5755	17.90	18.14	17.99	22.78
		5795	17.82	17.50	17.51	22.38

Table 23. RF Power Output, Test Results, Summed Power

RF Power Output, Port 1 802.11a

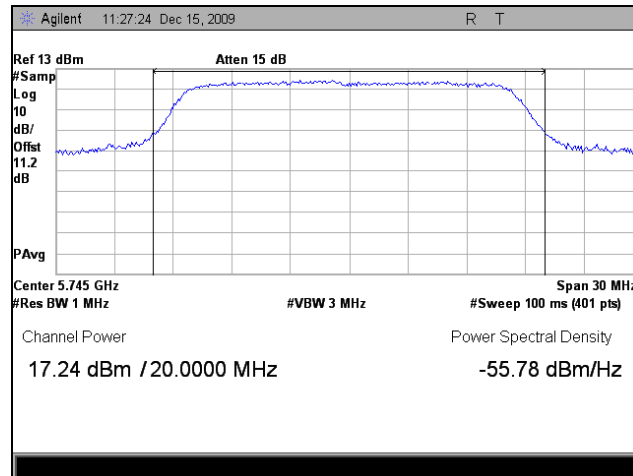

Plot 26. RF Power Output, Port 1, 802.11a, 5745 MHz

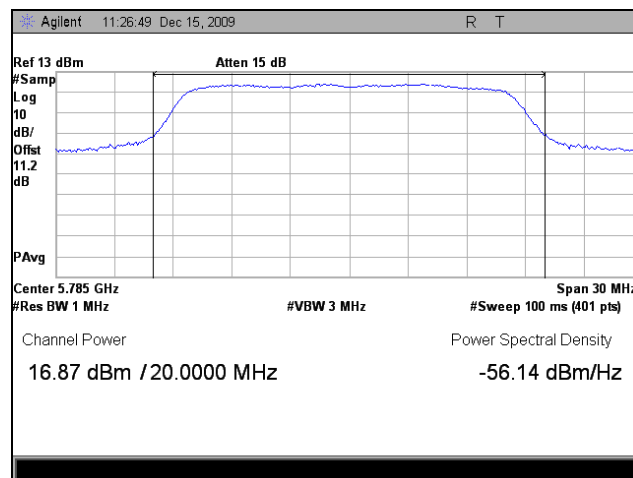

Plot 27. RF Power Output, Port 1, 802.11a, 5785 MHz

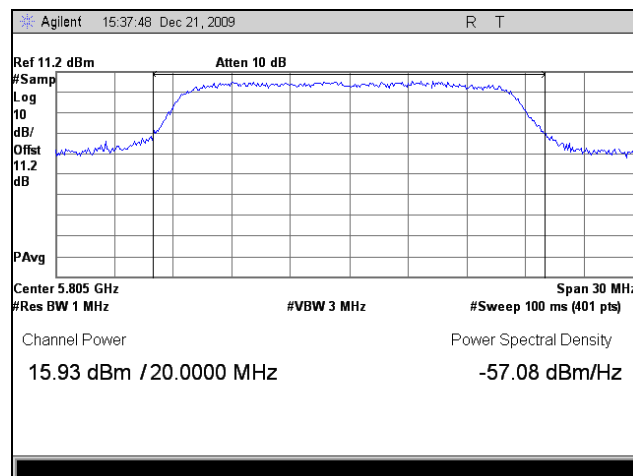

Plot 28. RF Power Output, Port 1, 802.11a, 5805 MHz

RF Power Output, Port 1, 802.11n 20MHz

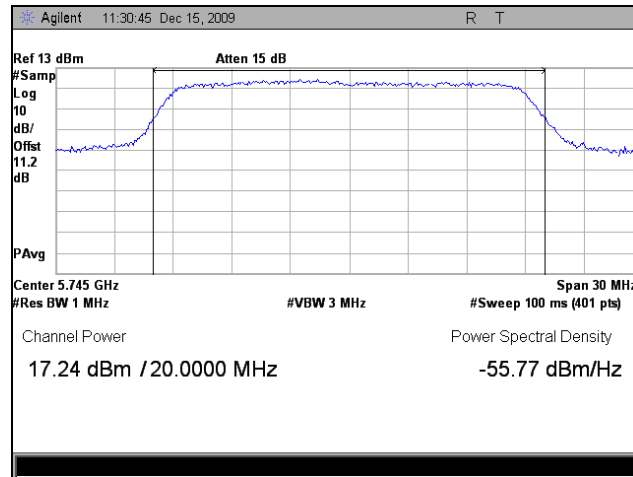

Plot 29. RF Power Output, Port 1, 802.11n 20MHz, 5745 MHz

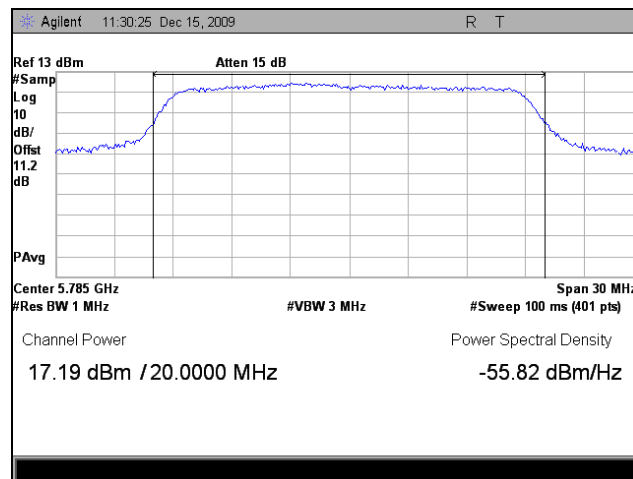

Plot 30. RF Power Output, Port 1, 802.11n 20MHz, 5785 MHz

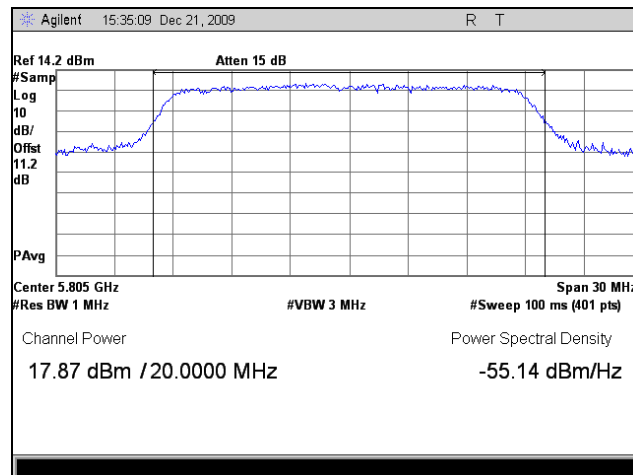

Plot 31. RF Power Output, Port 1, 802.11n 20MHz, 5805 MHz

RF Power Output, Port 1 802.11n 40MHz

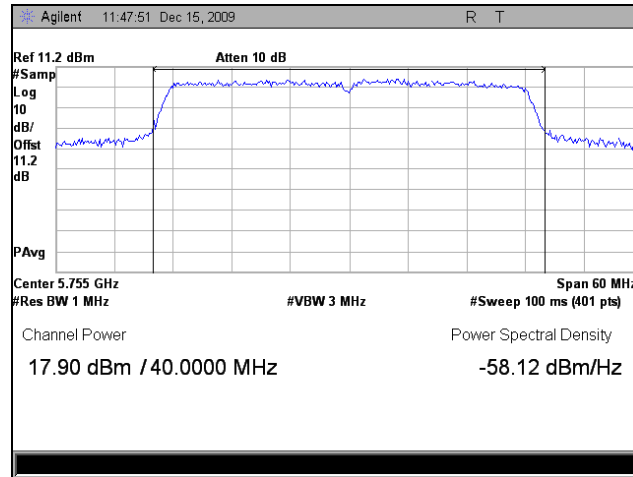

Plot 32. RF Power Output, Port 1, 802.11n 40MHz, 5755 MHz

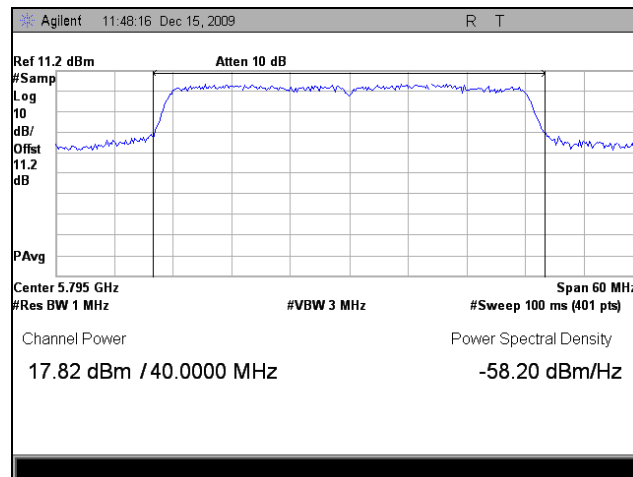

Plot 33. RF Power Output, Port 1, 802.11n 40MHz, 5795 MHz

RF Power Output, Port 2, 802.11n 20MHz

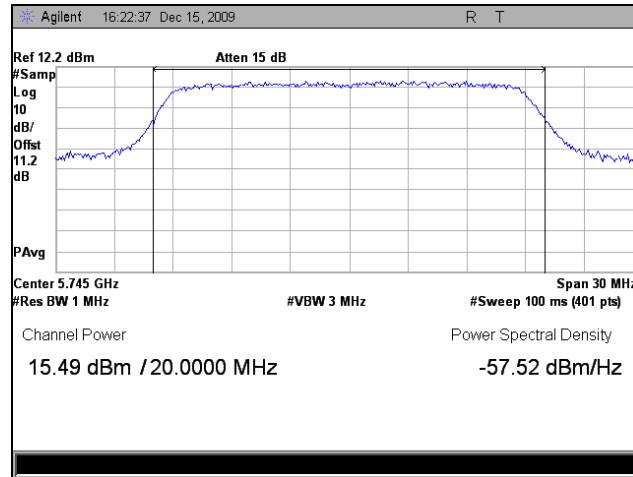

Plot 34. RF Power Output, Port 2, 802.11n 20MHz, 5745 MHz

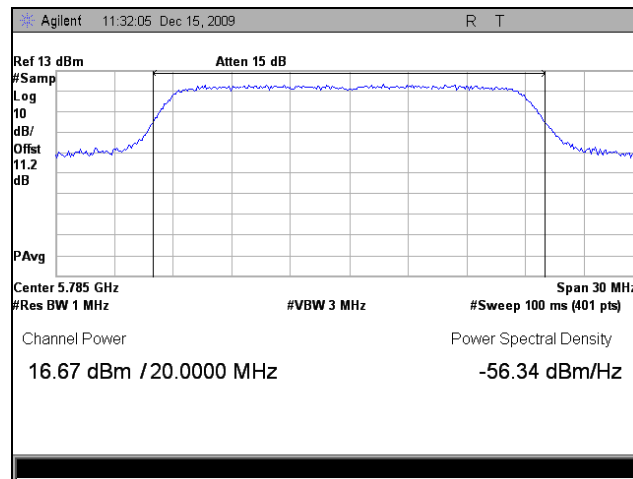

Plot 35. RF Power Output, Port 2, 802.11n 20MHz, 5785 MHz

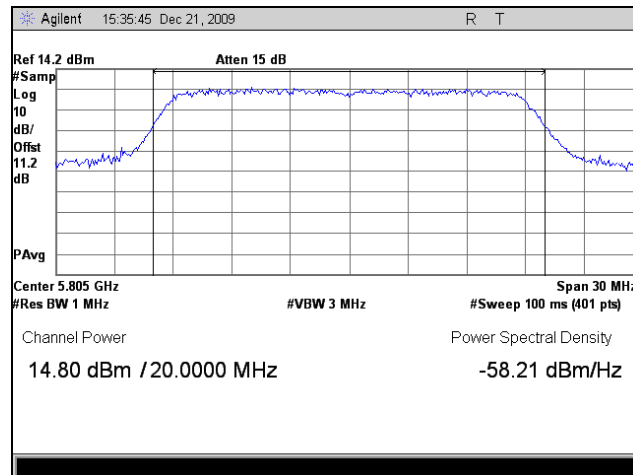

Plot 36. RF Power Output, Port 2, 802.11n 20MHz, 5805 MHz

RF Power Output, Port 2, 802.11n 40MHz

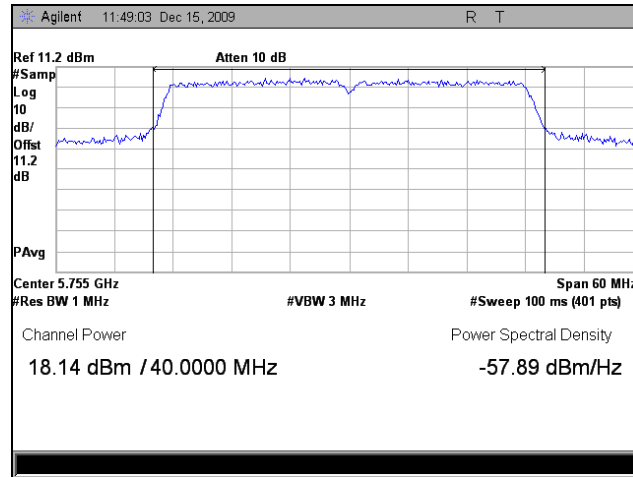

Plot 37. RF Power Output, Port 2, 802.11n 40MHz, 5755 MHz

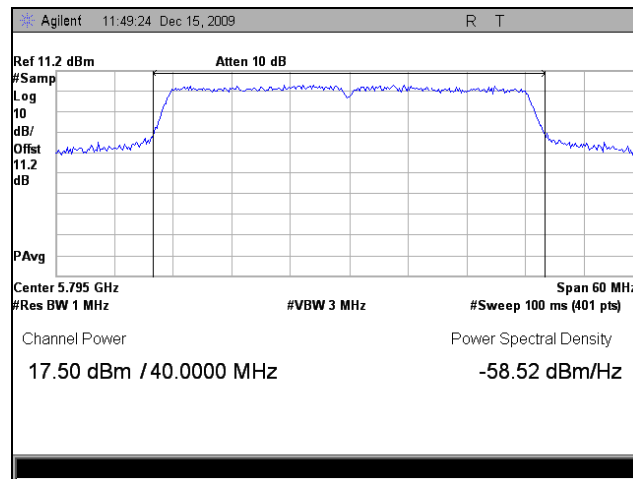

Plot 38. RF Power Output, Port 2, 802.11n 40MHz, 5795 MHz

RF Power Output, Port 3, 802.11n 20MHz

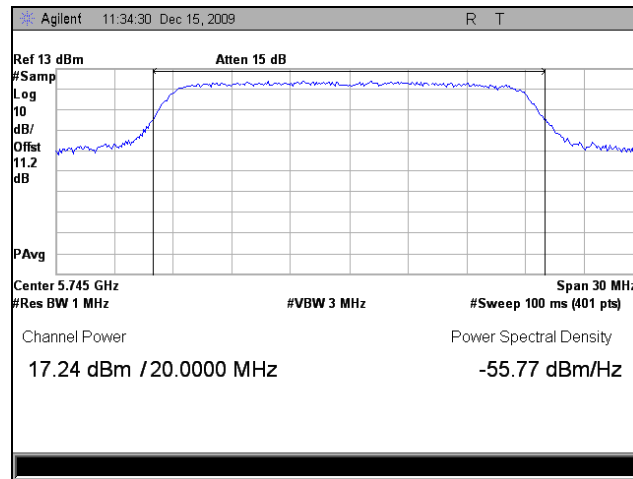

Plot 39. RF Power Output, Port 3, 802.11n 20MHz, 5745 MHz

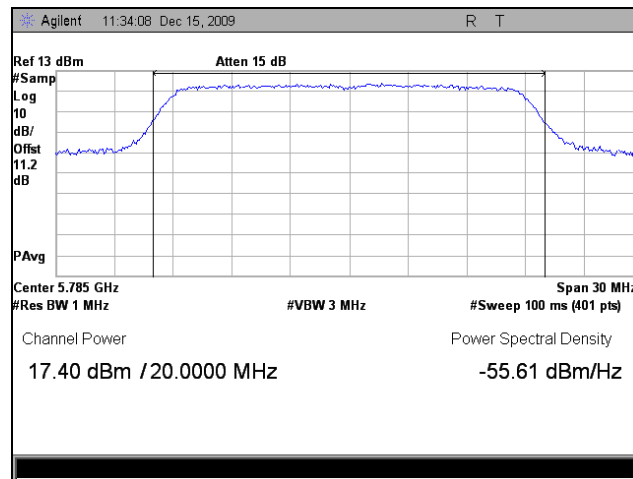

Plot 40. RF Power Output, Port 3, 802.11n 20MHz, 5785 MHz

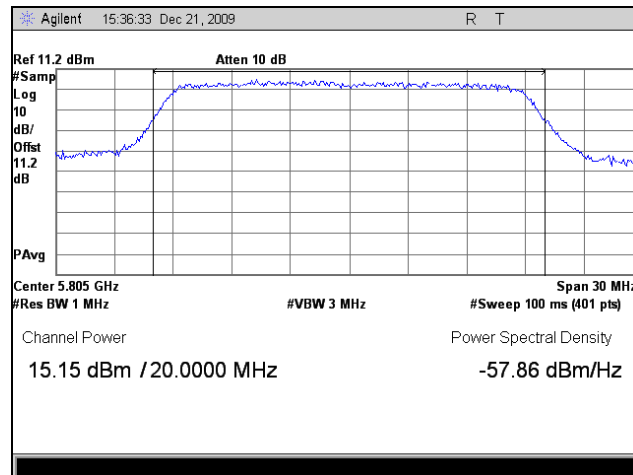

Plot 41. RF Power Output, Port 3, 802.11n 20MHz, 5805 MHz

RF Power Output, Port 3, 802.11n 40MHz

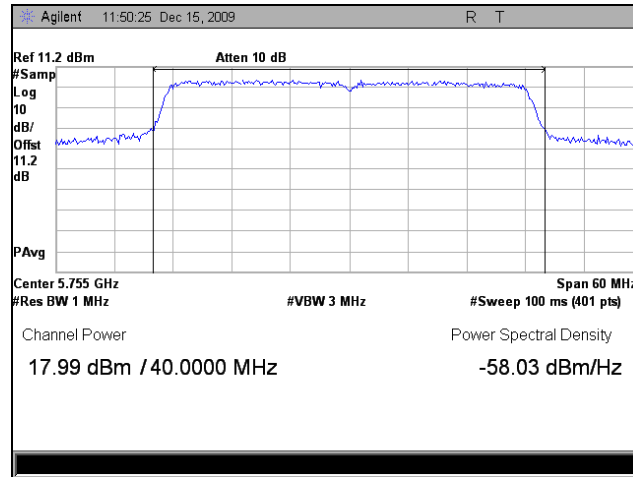

Plot 42. RF Power Output, Port 3, 802.11n 40MHz, 5755 MHz

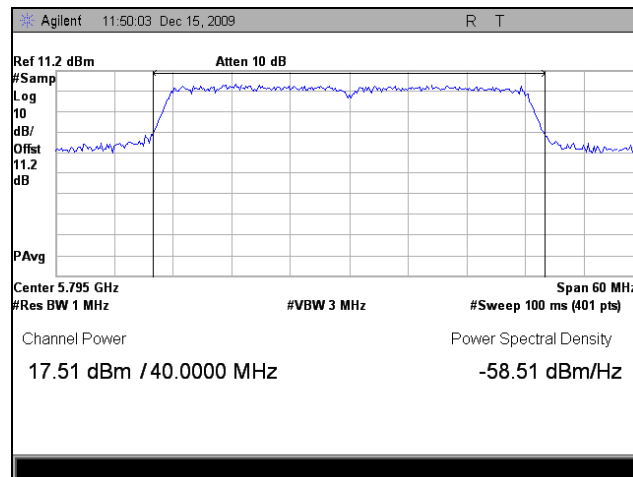

Plot 43. RF Power Output, Port 3, 802.11n 40MHz, 5795 MHz

Electromagnetic Compatibility Criteria for Intentional Radiators

§ 15.407(a)(1), (a)(2) Peak Power Spectral Density

- Test Requirements:** § 15.407(a)(3): For digitally modulated systems, the conducted peak power spectral density from the intentional radiator to the antenna shall not be greater than 17dBm/MHz in the frequency band 5.725 – 5.825GHz.
- Test Procedure:** The transmitter was connected directly to a Spectrum Analyzer through an attenuator. The power level was set to the maximum level on the EUT. The RBW was set to 1MHz and the VBW was set to 3MHz. The combined ports were measured using a splitter/combiner. The method of measurement #2 from the FCC Public Notice CA 02-2138 was used.
- Test Results:** Equipment complies with the peak power spectral density limits of § 15.407(a)(3). The peak power spectral density was determined from plots on the following page(s).
- Test Engineer(s):** Anderson Soungpanya
- Test Date(s):** 12/17/09

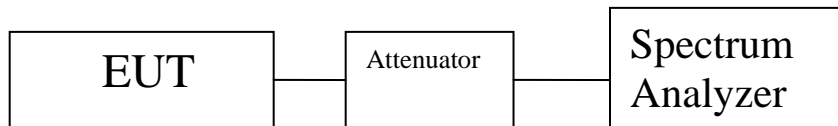

Figure 4. Peak Power Spectral Density Test Setup

Peak Power Spectral Density, Port 1					
Mode	Frequency (MHz)		Measured PPSD (dBm)	Limit (dBm)	Margin (dB)
802.11a	U-NII-3	5745	5.904	17	11.096
		5785	5.613	17	11.387
		5805	5.138	17	11.862
802.11n 20MHz	U-NII-3	5745	6.378	17	10.622
		5785	6.023	17	10.977
		5805	5.405	17	11.595
802.11n 40MHz	U-NII-3	5755	5.09	17	11.91
		5795	3.58	17	13.42

Table 24. Peak Power Spectral Density, Test Results, Port 1

Peak Power Spectral Density, Port 2					
Mode	Frequency (MHz)		Measured PPSD (dBm)	Limit (dBm)	Margin (dB)
802.11n 20MHz	U-NII-3	5745	4.182	17	12.818
		5785	5.788	17	11.212
		5805	4.821	17	12.179
802.11n 40MHz	U-NII-3	5755	3.63	17	13.37
		5795	1.77	17	15.23

Table 25. Peak Power Spectral Density, Test Results, Port 2

Peak Power Spectral Density, Port 3					
Mode	Frequency (MHz)		Measured PPSD (dBm)	Limit (dBm)	Margin (dB)
802.11n 20MHz	U-NII-3	5745	6.131	17	10.869
		5785	5.768	17	11.232
		5805	5.342	17	11.658
802.11n 40MHz	U-NII-3	5755	2.16	17	14.84
		5795	3.02	17	13.98

Table 26. Peak Power Spectral Density, Test Results, Port 3

Peak Power Spectral Density, Combined Ports					
Mode	Frequency (MHz)		Measured PPSD (dBm)	Limit (dBm)	Margin (dB)
802.11n 20MHz	U-NII-3	5745	10.06	17	6.94
		5785	9.89	17	7.11
		5805	9.657	17	7.343
802.11n 40MHz	U-NII-3	5755	9.262	17	7.738
		5795	8.545	17	8.455

Table 27. Peak Power Spectral Density, Test Results, Combined Ports

Peak Power Spectral Density, Port 1, 802.11a

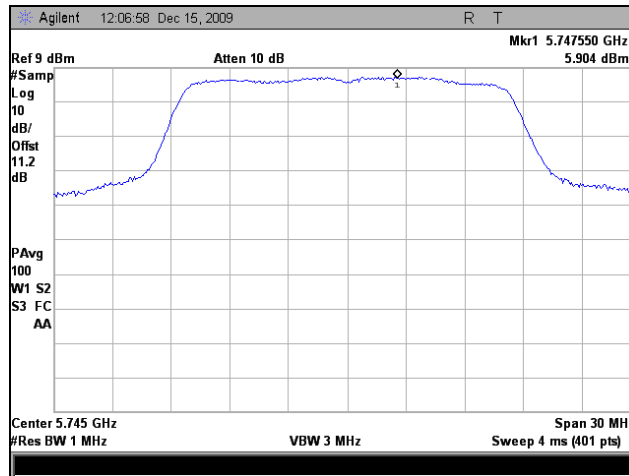

Plot 44. PPSD, Port 1, 802.11a, 5745 MHz

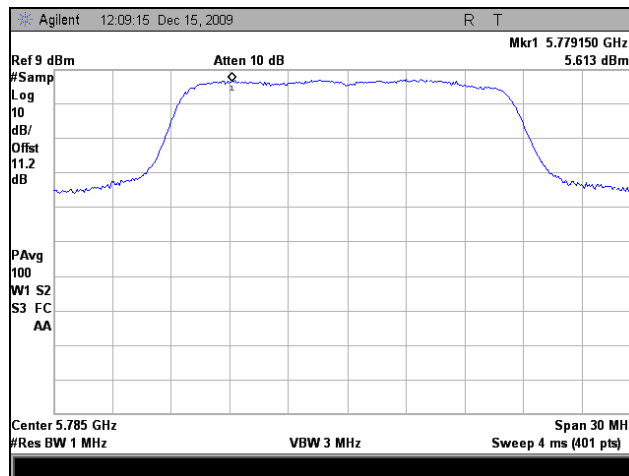

Plot 45. PPSD, Port 1, 802.11a 2, 5785 MHz

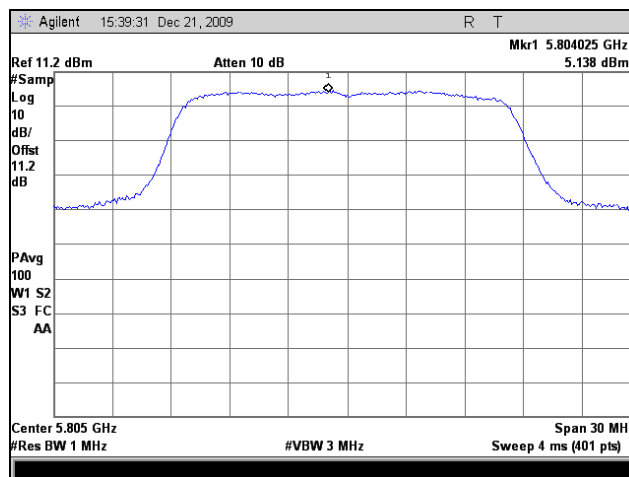

Plot 46. PPSD, Port 1, 802.11a, 5805 MHz

Peak Power Spectral Density, Port 1, 802.11n 20MHz

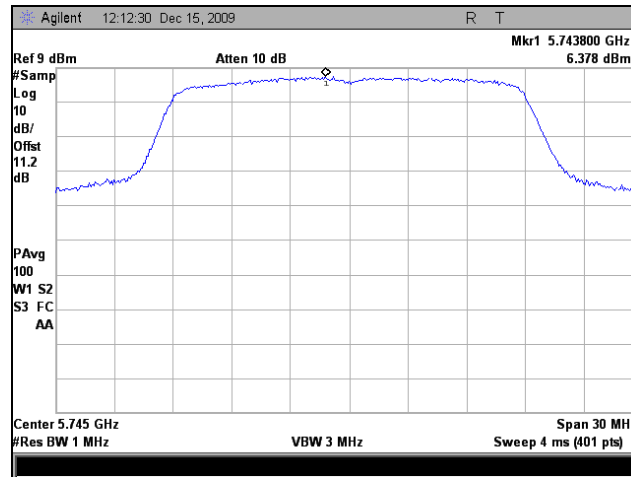

Plot 47. PPSD, \ Port 1, 802.11an 20MHz, 5745 MHz

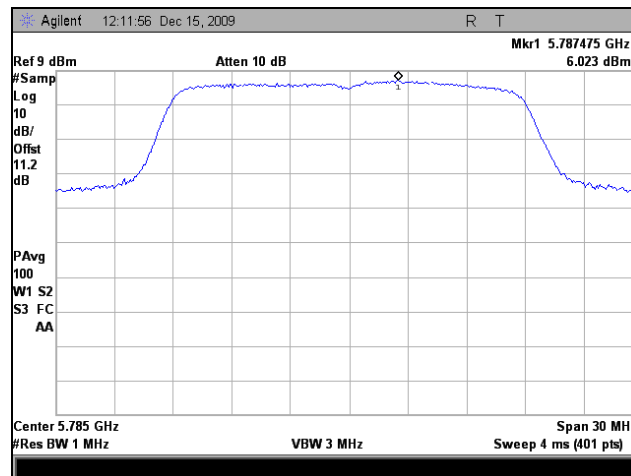

Plot 48. PPSD, Port 1, 802.11an 20MHz, 5785 MHz

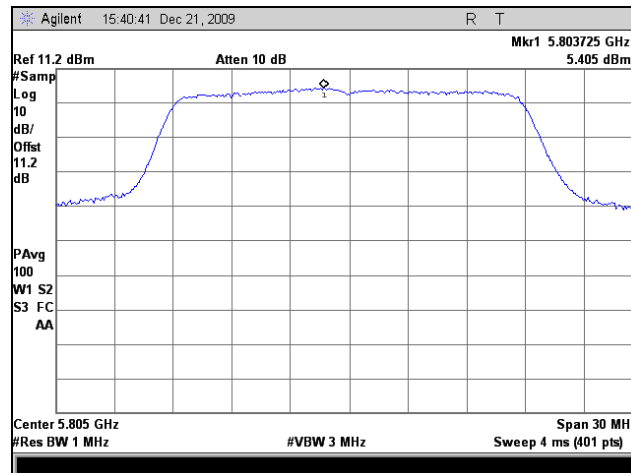

Plot 49. PPSD, Port 1, 802.11an 20MHz, 5805 MHz

Peak Power Spectral Density, Port 1, 802.11n 40MHz

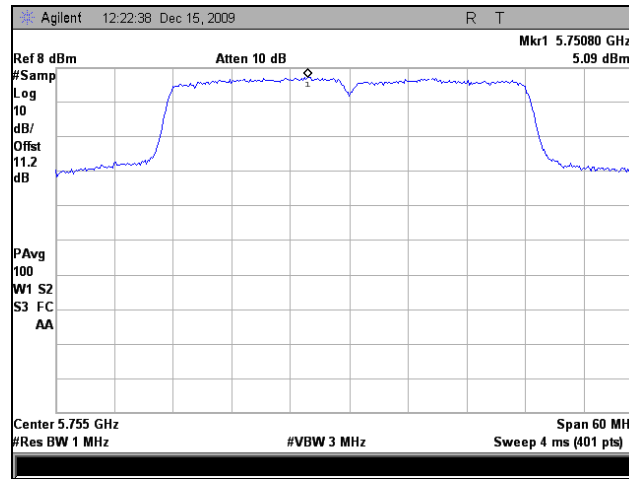

Plot 50. PPSD, Port 1, 802.11n 40MHz, 5755 MHz

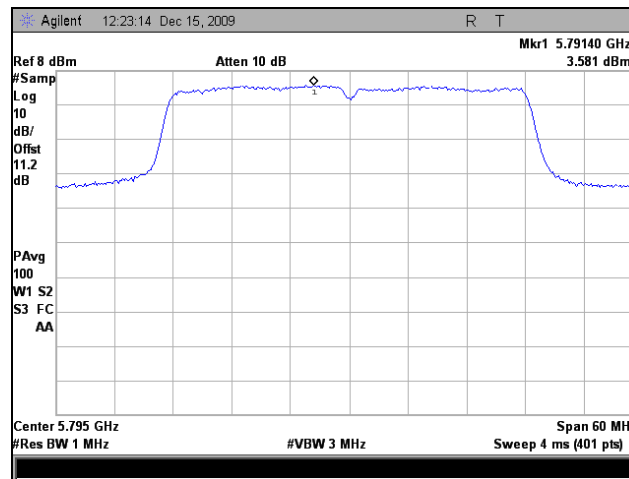

Plot 51. PPSD, Port 1, 802.11n 40MHz, 5795 MHz

Peak Power Spectral Density, Port 2, 802.11n 20MHz

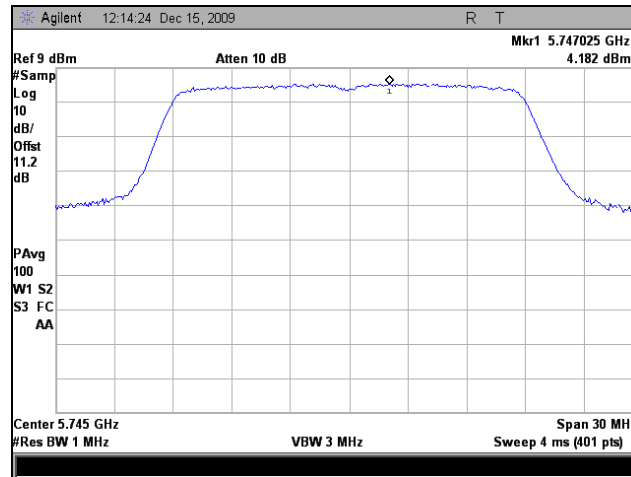

Plot 52. PPSD, Port 2, 802.11n 20MHz, 5745 MHz

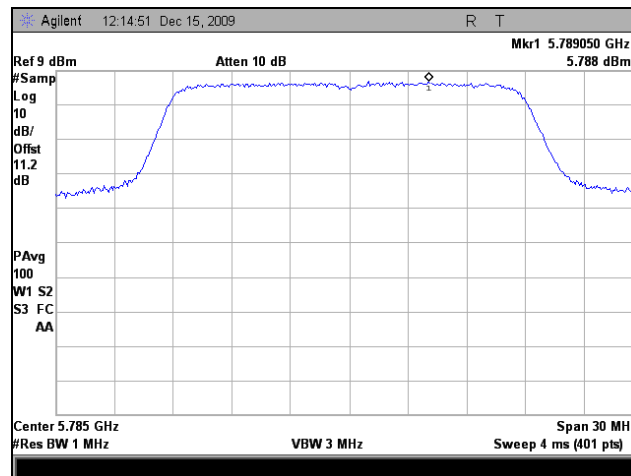

Plot 53. PPSD, Port 2, 802.11n 20MHz, 5785 MHz

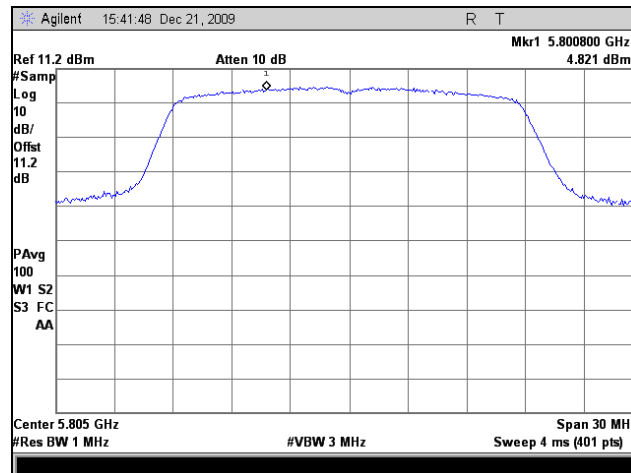

Plot 54. PPSD, Port 2, 802.11n 20MHz, 5805 MHz

Peak Power Spectral Density, Port 2, 802.11n 40MHz

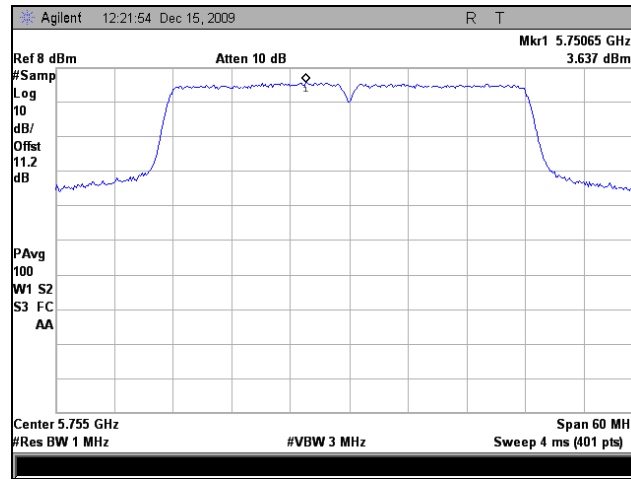

Plot 55. PPSD, Port 2, 802.11n 40MHz, 5755 MHz

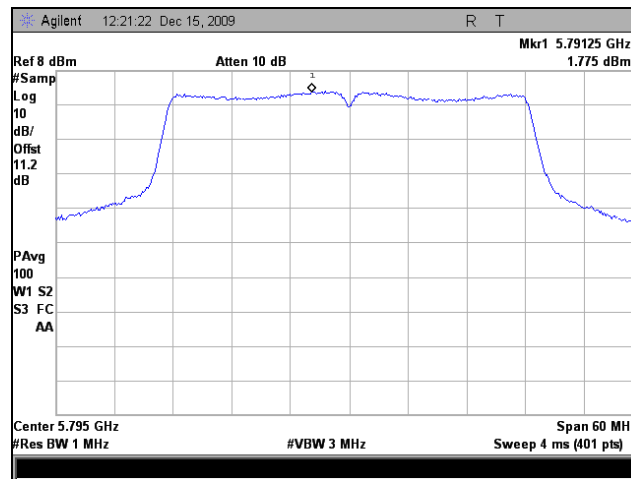

Plot 56. PPSD, Port 2, 802.11n 40MHz, 5795 MHz

Peak Power Spectral Density, Port 3, 802.11n 20MHz

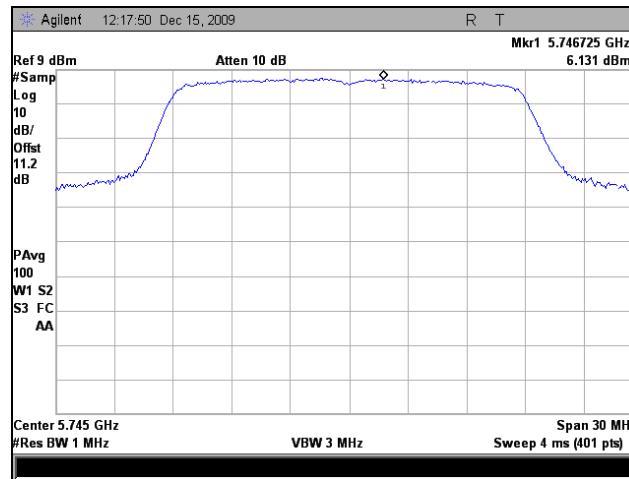

Plot 57. PPSD, Port 3, 802.11n 20MHz, 5745 MHz

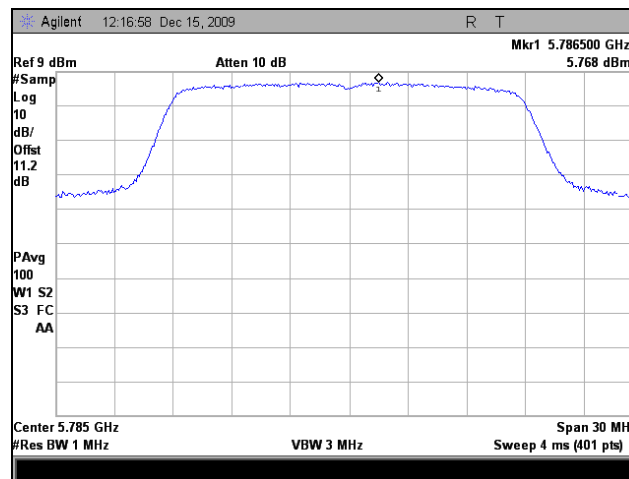

Plot 58. PPSD, Port 3, 802.11n 20MHz, 5785 MHz

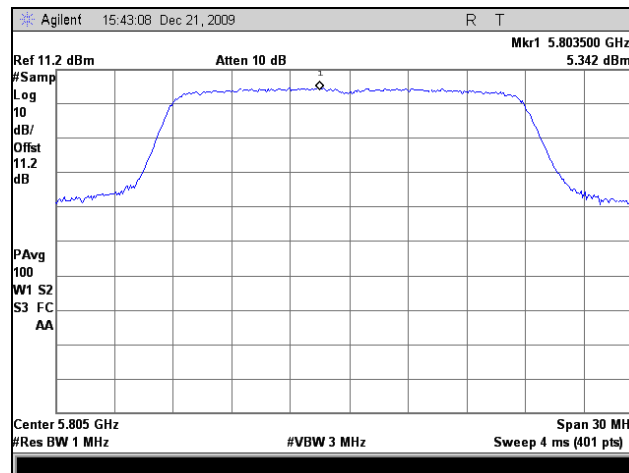

Plot 59. PPSD, Port 3, 802.11n 20MHz, 5805 MHz

Peak Power Spectral Density, Port 3, 802.11n 40MHz

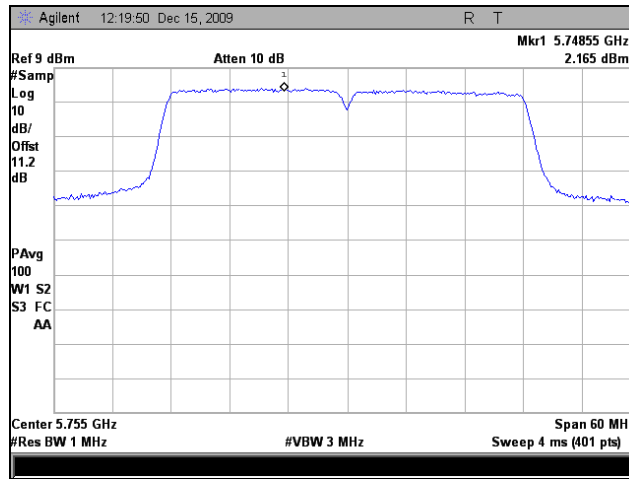

Plot 60. PPSD, Port 3, 802.11n 40MHz, 5755 MHz

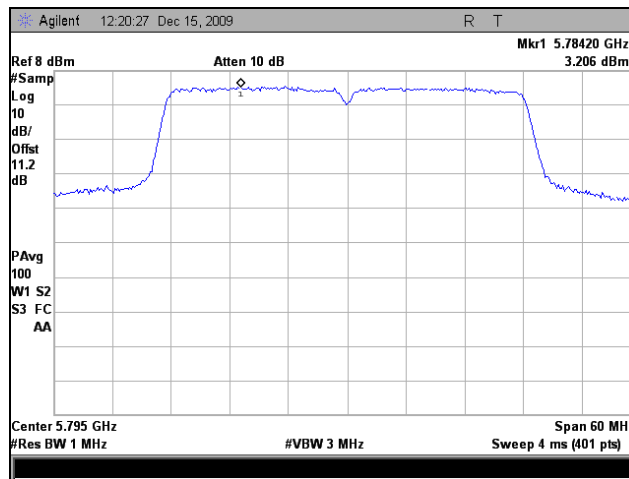

Plot 61. PPSD, Port 3, 802.11n 40MHz, 5795 MHz

Peak Power Spectral Density, Combined Ports, 802.11n 20MHz

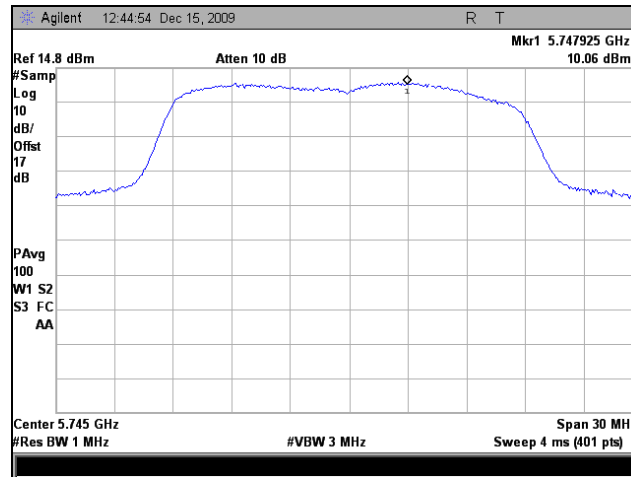

Plot 62. PPSD, Combined Ports, 802.11n 20MHz, 5745 MHz

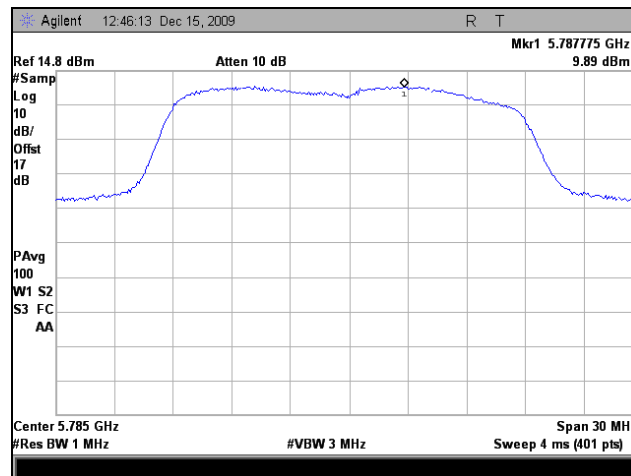

Plot 63. PPSD, Combined Ports, 802.11n 20MHz, 5785 MHz

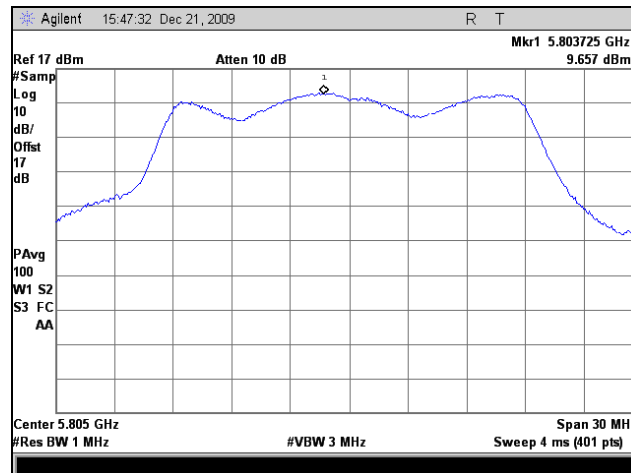

Plot 64. PPSD, Combined Ports, 802.11n 20MHz, 5805 MHz

Peak Power Spectral Density, Combined Ports, 802.11n 40MHz

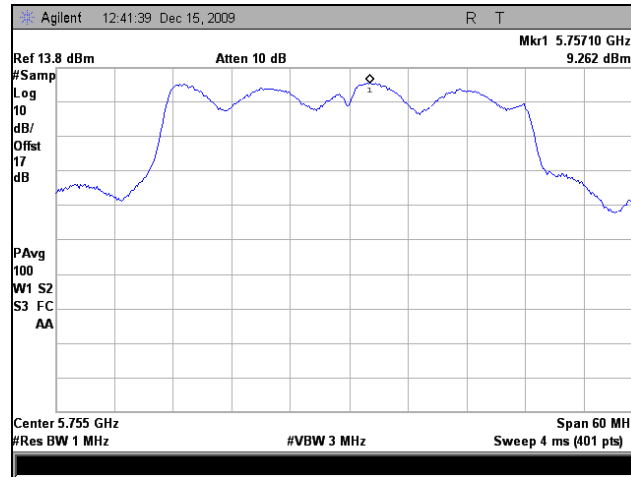

Plot 65. PPSD, Combined Ports, 802.11n 40MHz, 5755 MHz

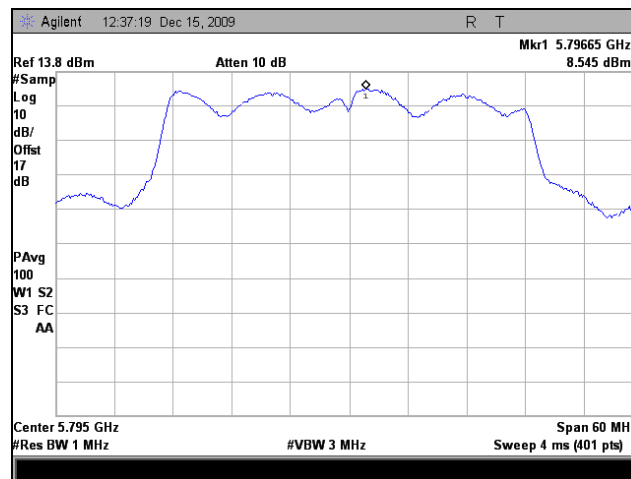

Plot 66. PPSD, Combined Ports, 802.11n 40MHz, 5795 MHz

Electromagnetic Compatibility Criteria for Intentional Radiators

§ 15.407(a)(6) Peak Excursion Ratio

Test Requirements: § 15.407(a)(6): For digitally modulated systems, the peak excursion of the modulation envelope to the peak transmit power shall not exceed 13dB across any 1MHz bandwidth of the emission bandwidth whichever is less.

Test Procedure: The method of measurement #2 from the FCC Public Notice CA 02-2138 was used. The EUT was connected directly to the spectrum analyzer through cabling and attenuation. The 1st trace on the spectrum analyzer was set to RBW=1MHz, VBW=3MHz. The peak detector mode was used and the trace max held. The 2nd trace on the spectrum analyzer was set to a RBW=1MHz, VBW=30 KHz. The detector mode was set to sample detector.

The Peak Excursion Ratio was determined from the difference between the maximum found in each trace.

Test Results: Equipment complies with the peak excursion ratio limits of § 15.407(a)(6). The peak excursion ratio was determined from plots on the following page(s).

Test Engineer(s): Anderson Soungpanya

Test Date(s): 12/17/09

Peak Excursion Ratio, Port 1					
Mode	Frequency (MHz)	Excursion Ratio (dBm)	Limit (dBm)	Margin (dB)	
802.11a	U-NII-3	5745	9.492	13	3.508
		5785	10.09	13	2.91
		5805	8.461	13	4.539
802.11n 20MHz	U-NII-3	5745	10.24	13	2.76
		5785	10.82	13	2.18
		5805	9.787	13	3.213
802.11n 40MHz	U-NII-3	5755	12.26	13	0.74
		5795	11.42	13	1.58

Table 28. Peak Excursion Ration, Test Results, Port 1

Peak Excursion Ratio, Port 2					
Mode	Frequency (MHz)		Excursion Ratio (dBm)	Limit (dBm)	Margin (dB)
802.11n 20MHz	U-NII-3	5745	11.14	13	1.86
		5785	9.76	13	3.24
		5805	10.67	13	2.33
802.11n 40MHz	U-NII-3	5755	11.23	13	1.77
		5795	12.02	13	0.98

Table 29. Peak Excursion Ratio, Test Results, Port 2

Peak Excursion Ratio, Port 3					
Mode	Frequency (MHz)		Excursion Ratio (dBm)	Limit (dBm)	Margin (dB)
802.11n 20MHz	U-NII-3	5745	10.48	13	2.52
		5785	10.59	13	2.41
		5805	10.7	13	2.3
802.11n 40MHz	U-NII-3	5755	12.64	13	0.36
		5795	12.4	13	0.6

Table 30. Peak Excursion Ratio, Test Results, Port 3

Peak Excursion Ratio, Port 1, 802.11a

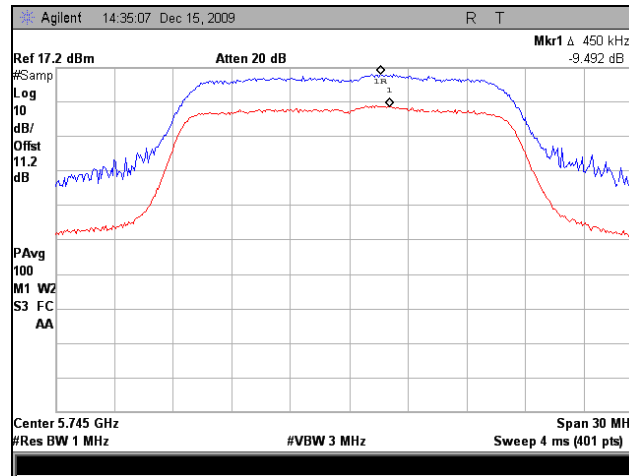

Plot 67. Peak Excursion, Port 1, 802.11a, 5745 MHz

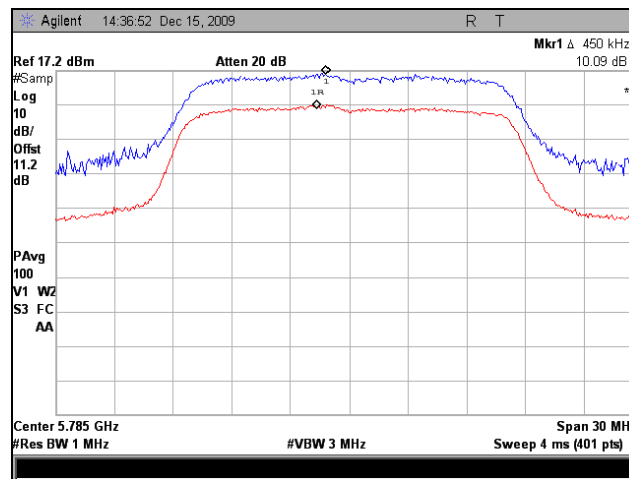

Plot 68. Peak Excursion, Port 1, 802.11a, 5785 MHz

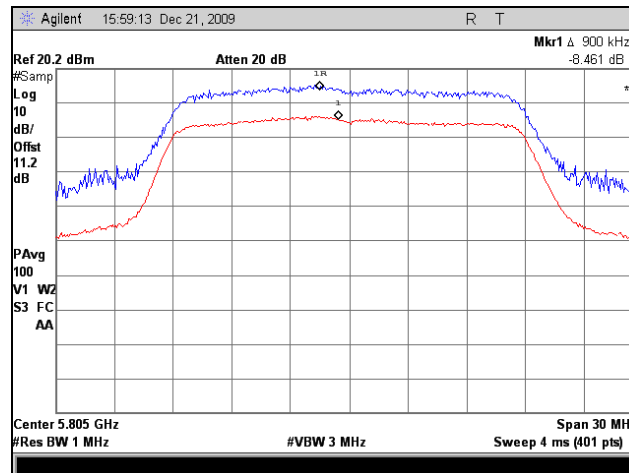

Plot 69. Peak Excursion, Port 1, 802.11a, 5805 MHz

Peak Excursion Ratio, 7200 Outdoor, Port 1, 802.11n 20MHz

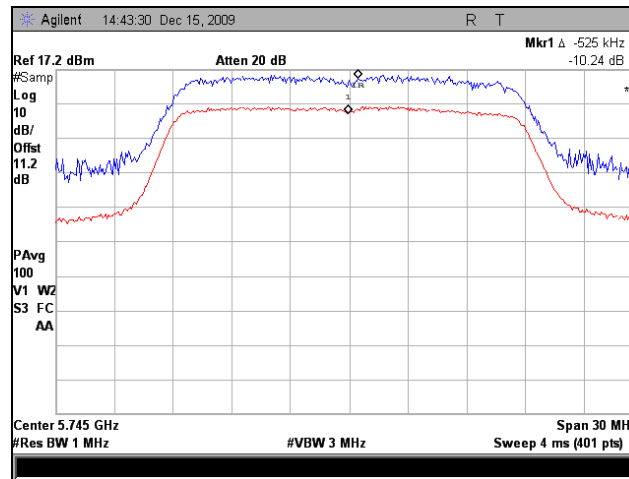

Plot 70. Peak Excursion, Port 1, 802.11n 20MHz, 5745 MHz

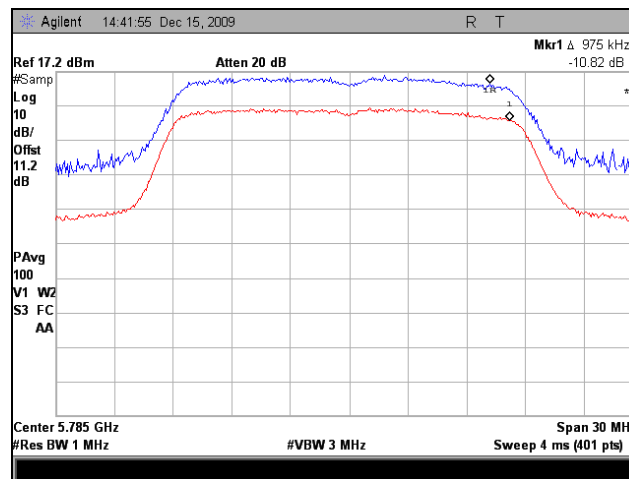

Plot 71. Peak Excursion, Port 1, 802.11n 20MHz, 5785 MHz

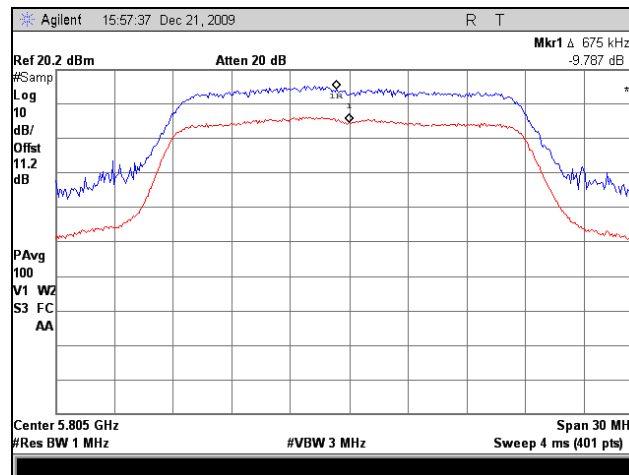

Plot 72. Peak Excursion, Port 1, 802.11n 20MHz, 5805 MHz

Peak Excursion Ratio, Port 1, 802.11n 40MHz

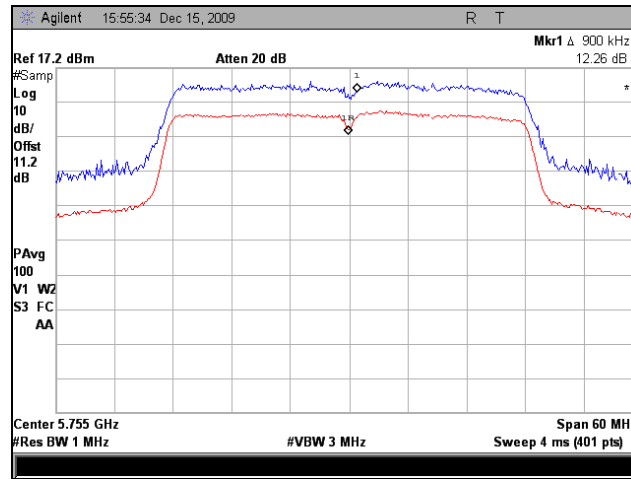

Plot 73. Peak Excursion, Port 1, 802.11n 40MHz, 5755 MHz

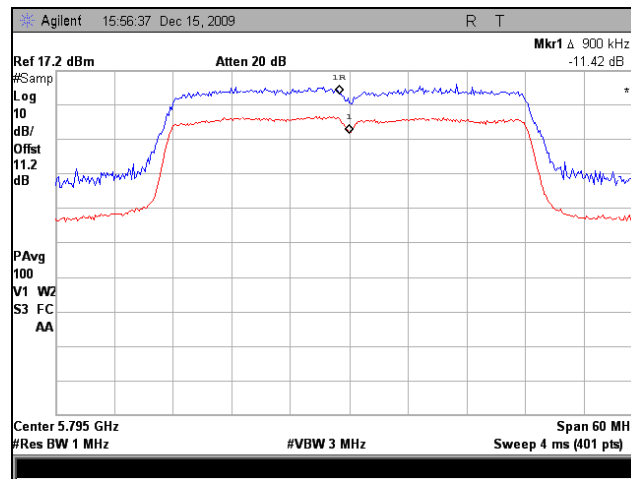

Plot 74. Peak Excursion, Port 1, 802.11n 40MHz, 5795 MHz

Peak Excursion Ratio, Port 2, 802.11n 20MHz

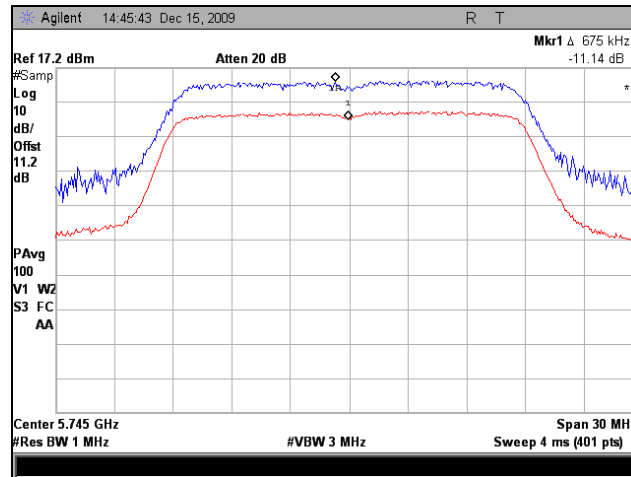

Plot 75. Peak Excursion, Port 2, 802.11n 20MHz, 5745 MHz

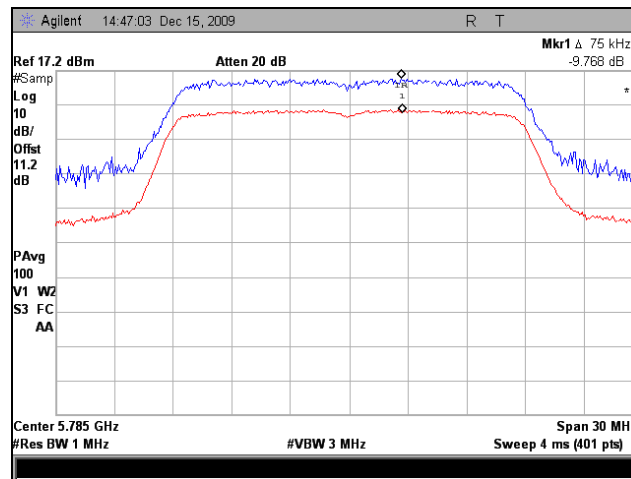

Plot 76. Peak Excursion, Port 2, 802.11n 20MHz, 5785 MHz

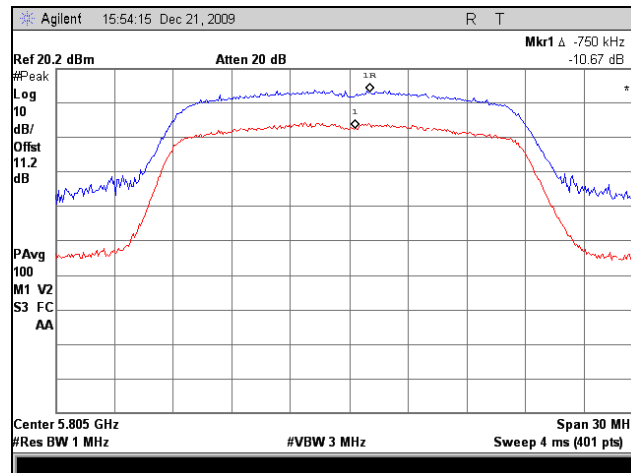

Plot 77. Peak Excursion, Port 2, 802.11n 20MHz, 5805 MHz

Peak Excursion Ratio, Port 2, 802.11n 40MHz

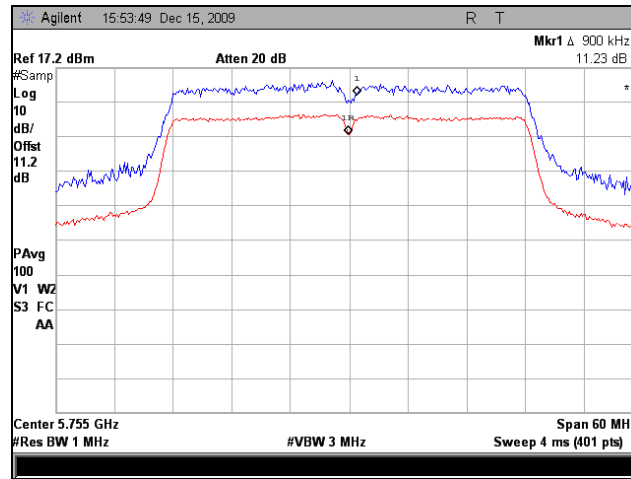

Plot 78. Peak Excursion, Port 2, 802.11n 40MHz, 5755 MHz

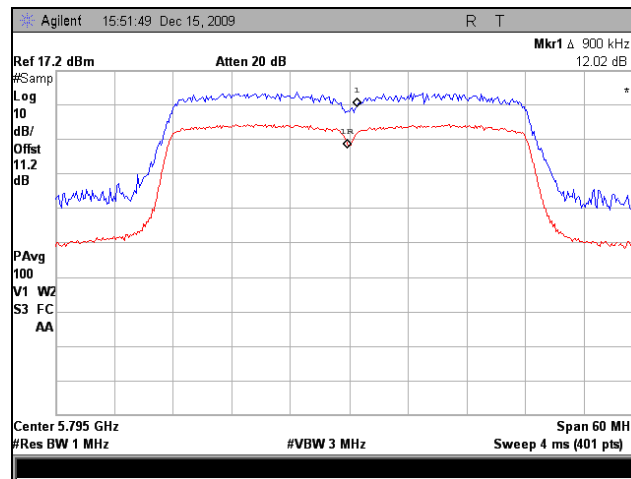

Plot 79. Peak Excursion, Port 2, 802.11n 40MHz, 5795 MHz

Peak Excursion Ratio, Port 3, 802.11n 20MHz

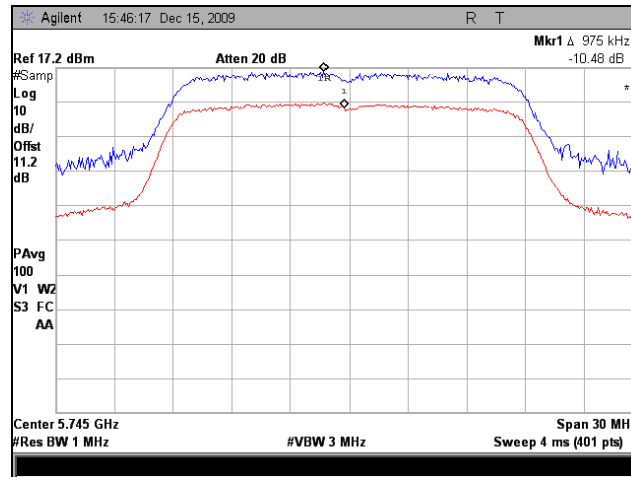

Plot 80. Peak Excursion, Port 3, 802.11n 20MHz, 5745 MHz

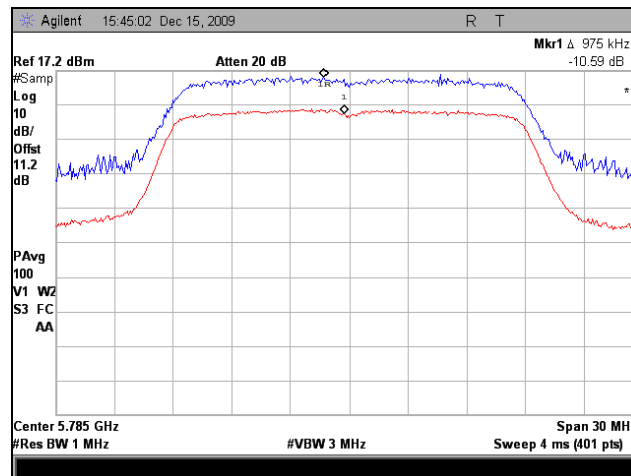

Plot 81. Peak Excursion, Port 3, 802.11n 20MHz, 5785 MHz

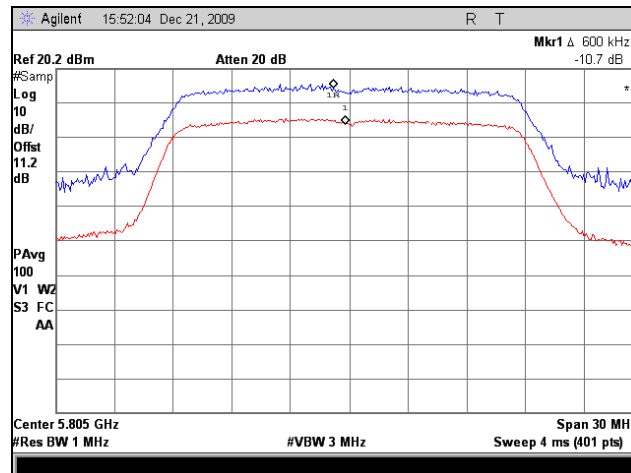

Plot 82. Peak Excursion, Port 3, 802.11n 20MHz, 5805 MHz

Peak Excursion Ratio, Port 3, 802.11n 40MHz

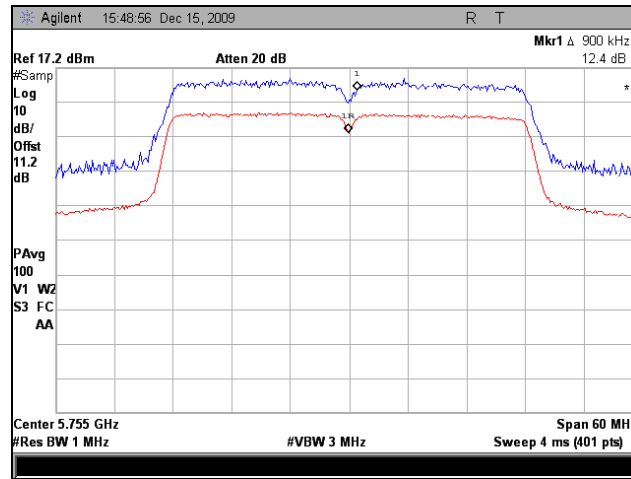

Plot 83. Peak Excursion, Port 3, 802.11n 40MHz, 5755 MHz

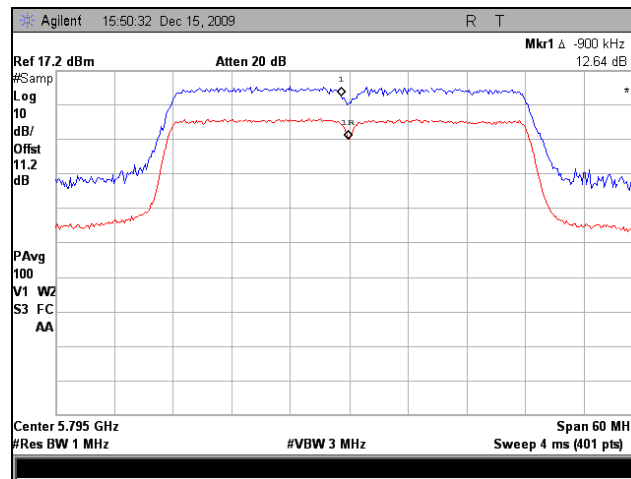

Plot 84. Peak Excursion, Port 3, 802.11n 40MHz, 5795 MHz

Electromagnetic Compatibility Criteria for Intentional Radiators

§ 15.407(b)(1),(2), (5), (6) Undesirable Emissions

Test Requirements: § 15.407(b)(1),(2), (5), (6); §15.205: Emissions outside the frequency band.

§ 15.407(b)(1): In any 1MHz bandwidth outside the frequency band 5.15-5.25GHz in which the spread spectrum or digitally modulated intentional radiator is operating, the radio frequency power shall not exceed -27dBm.

§ 15.407(b)(2): In any 1MHz bandwidth outside the frequency band 5.25-5.35GHz in which the spread spectrum or digitally modulated intentional radiator is operating, the radio frequency power shall not exceed -27dBm.

§ 15.407(b)(4): In any 1MHz bandwidth outside the frequency band 5.725-5.825GHz in which the spread spectrum or digitally modulated intentional radiator is operating, the radio frequency power shall not exceed -17dBm.

§ 15.407(b)(6): Radiated emissions which fall in the restricted bands, as defined in § 15.205(a), must also comply with the radiated emission limits specified in § 15.209(a).

§15.205(a): Except as shown in paragraph (d) of this section, only spurious emissions are permitted in any of the frequency bands listed below:

MHz	MHz	MHz	GHz
0.090–0.110-----	16.42–16.423	399.9–410	4.5–5.15
¹ 0.495–0.505-----	16.69475–16.69525	608–614	5.35–5.46
2.1735–2.1905-----	16.80425–16.80475	960–1240	7.25–7.75
4.125–4.128-----	25.5–25.67	1300–1427	8.025–8.5
4.17725–4.17775-----	37.5–38.25	1435–1626.5	9.0–9.2
4.20725–4.20775-----	73–74.6	1645.5–1646.5	9.3–9.5
6.215–6.218-----	74.8–75.2	1660–1710	10.6–12.7
6.26775–6.26825-----	108–121.94	1718.8–1722.2	13.25–13.4
6.31175–6.31225-----	123–138	2200–2300	14.47–14.5
8.291–8.294-----	149.9–150.05	2310–2390	15.35–16.2
8.362–8.366-----	156.52475–156.52525	2483.5–2500	17.7–21.4
8.37625–8.38675-----	156.7–156.9	2655–2900	22.01–23.12
8.41425–8.41475-----	162.0125–167.17	3260–3267	23.6–24.0
12.29–12.293-----	167.72–173.2	3332–3339	31.2–31.8
12.51975–12.52025-----	240–285	3345.8–3358 36.	43–36.5
12.57675–12.57725-----	322–335.4	3600–4400	(²)

Table 31. Restricted Bands of Operation

Test Procedure: The EUT was installed placed on a 0.8m-high wooden table inside a semi-anechoic chamber. The harmonic frequencies the carriers were recorded for reference for final measurements. A receiving horn antenna was placed 3m away from the EUT. Unless otherwise specified, measurements were made using 1MHz RBW & 1MHz VBW for peak measurements and 1MHz RBW & 10Hz VBW for average measurements on a spectrum analyzer.

For each harmonic of the carrier frequency, the turntable was rotated, the positions of the interface cables were varied, and the antenna height was varied between 1 m and 4 m, in order to find the maximum radiated emissions.

The equipment isotropic radiated power (EIRP) at -17dBm/MHz was converted to field strength at 78.26dBuV/m. At the band edge of each band, the EIRP energy measurement is integrated to show the total power over 1MHz.

Test Results: The EUT was found compliant with the requirement(s) of this section. Measured emissions were below applicable limits.

Test Engineer(s): Anderson Soungpanya

Test Date(s): 12/17/09

Electromagnetic Compatibility Criteria for Intentional Radiators

Harmonic Emissions Requirements – Radiated (802.11a)

Freq. (GHz)	Antenna Polarity (H/V)	Raw Amp. @ 3 m (Peak) / (Avg.)	P. Amp (dB)	Ant. Cor. Factor (dB/m)	Cable Loss (dB)	Distance Correction Factor 1m to 3m (dBuV/m)	EUT Field Strength Final Amp. (dBuV/m)	Limit Detector Peak / Avg. (Peak) / (Avg.)	Limit @ 3 m (dBuV/m)	Delta (dB)
11.49	V	48.68	34.86	30.43	7.72	-9.54	42.43	Peak	74	-31.57
11.49	V	33.42	34.86	30.43	7.72	-9.54	27.17	Avg.	54	-26.83
17.235	V	46.87	34.01	32.19	10.17	-9.54	45.68	Peak	74	-28.32
17.235	V	33.49	34.01	32.19	10.17	-9.54	32.30	Avg.	54	-21.70

Table 32. Radiated Harmonics, 802.11a, 5 dBi Omni, 5745 MHz

Note: All other emissions were measured at the noise floor of the spectrum analyzer.

Freq. (GHz)	Antenna Polarity (H/V)	Raw Amp. @ 3 m (Peak) / (Avg.)	P. Amp (dB)	Ant. Cor. Factor (dB/m)	Cable Loss (dB)	Distance Correction Factor 1m to 3m (dBuV/m)	EUT Field Strength Final Amp. (dBuV/m)	Limit Detector Peak / Avg. (Peak) / (Avg.)	Limit @ 3 m (dBuV/m)	Delta (dB)
11.57	V	47.42	34.91	30.50	7.63	-9.54	41.10	Peak	74	-32.90
11.57	V	33.98	34.91	30.50	7.63	-9.54	27.66	Avg.	54	-26.34
17.355	V	46.72	33.93	32.15	10.33	-9.54	45.73	Peak	74	-28.27
17.355	V	32.94	33.93	32.15	10.33	-9.54	31.95	Avg.	54	-22.05

Table 33. Radiated Harmonics, 802.11a, 5 dBi Omni, 5785 MHz

Note: All other emissions were measured at the noise floor of the spectrum analyzer.

Freq. (GHz)	Antenna Polarity (H/V)	Raw Amp. @ 3 m (Peak) / (Avg.)	P. Amp (dB)	Ant. Cor. Factor (dB/m)	Cable Loss (dB)	Distance Correction Factor 1m to 3m (dBuV/m)	EUT Field Strength Final Amp. (dBuV/m)	Limit Detector Peak / Avg. (Peak) / (Avg.)	Limit @ 3 m (dBuV/m)	Delta (dB)
11.61	V	48.49	34.93	30.53	7.54	-9.54	42.09	Peak	74	-31.91
11.61	V	34.84	34.93	30.53	7.54	-9.54	28.44	Avg.	54	-25.56
17.415	V	45.9	33.91	32.14	10.42	-9.54	45.02	Peak	74	-28.98
17.415	V	32.32	33.91	32.14	10.42	-9.54	31.44	Avg.	54	-22.56

Table 34. Radiated Harmonics, 802.11a, 5 dBi Omni, 5805 MHz

Note: All other emissions were measured at the noise floor of the spectrum analyzer.

Freq. (GHz)	Antenna Polarity (H/V)	Raw Amp. @ 3 m (Peak) / (Avg.)	P. Amp (dB)	Ant. Cor. Factor (dB/m)	Cable Loss (dB)	Distance Correction Factor 1m to 3m (dBuV/m)	EUT Field Strength Final Amp. (dBuV/m)	Limit Detector Peak / Avg. (Peak) / (Avg.)	Limit @ 3 m (dBuV/m)	Delta (dB)
11.49	V	44.21	34.86	30.43	7.72	-9.54	37.96	Peak	74	-36.04
11.49	V	32.48	34.86	30.43	7.72	-9.54	26.23	Avg.	54	-27.77
17.235	V	45.39	34.01	32.19	10.17	-9.54	44.20	Peak	74	-29.80
17.235	V	32.93	34.01	32.19	10.17	-9.54	31.74	Avg.	54	-22.26

Table 35. Radiated Harmonics, 802.11a, 9 dBi Omni, 5745 MHz

Note: All other emissions were measured at the noise floor of the spectrum analyzer.

Freq. (GHz)	Antenna Polarity (H/V)	Raw Amp. @ 3 m (Peak) / (Avg.)	P. Amp (dB)	Ant. Cor. Factor (dB/m)	Cable Loss (dB)	Distance Correction Factor 1m to 3m (dBuV/m)	EUT Field Strength Final Amp. (dBuV/m)	Limit Detector Peak / Avg. (Peak) / (Avg.)	Limit @ 3 m (dBuV/m)	Delta (dB)
11.57	V	45.22	34.91	30.50	7.63	-9.54	38.90	Peak	74	-35.10
11.57	V	33.08	34.91	30.50	7.63	-9.54	26.76	Avg.	54	-27.24
17.355	V	46.38	33.93	32.15	10.33	-9.54	45.39	Peak	74	-28.61
17.355	V	32.87	33.93	32.15	10.33	-9.54	31.88	Avg.	54	-22.12

Table 36. Radiated Harmonics, 802.11a, 9 dBi Omni, 5785 MHz

Note: All other emissions were measured at the noise floor of the spectrum analyzer.

Freq. (GHz)	Antenna Polarity (H/V)	Raw Amp. @ 3 m (Peak) / (Avg.)	P. Amp (dB)	Ant. Cor. Factor (dB/m)	Cable Loss (dB)	Distance Correction Factor 1m to 3m (dBuV/m)	EUT Field Strength Final Amp. (dBuV/m)	Limit Detector Peak / Avg. (Peak) / (Avg.)	Limit @ 3 m (dBuV/m)	Delta (dB)
11.61	V	45.02	34.93	30.53	7.54	-9.54	38.62	Peak	74	-35.38
11.61	V	32.98	34.93	30.53	7.54	-9.54	26.58	Avg.	54	-27.42
17.415	V	47.32	33.91	32.14	10.42	-9.54	46.44	Peak	74	-27.56
17.415	V	33.15	33.91	32.14	10.42	-9.54	32.27	Avg.	54	-21.73

Table 37. Radiated Harmonics, 802.11a, 9 dBi Omni, 5805 MHz

Note: All other emissions were measured at the noise floor of the spectrum analyzer.

Freq. (GHz)	Antenna Polarity (H/V)	Raw Amp. @ 3 m (Peak) / (Avg.)	P. Amp (dB)	Ant. Cor. Factor (dB/m)	Cable Loss (dB)	Distance Correction Factor 1m to 3m (dBuV/m)	EUT Field Strength Final Amp. (dBuV/m)	Limit Detector Peak / Avg. (Peak) / (Avg.)	Limit @ 3 m (dBuV/m)	Delta (dB)
11.49	V	47.02	34.86	30.43	7.72	-9.54	40.77	Peak	74	-33.23
11.49	V	31.94	34.86	30.43	7.72	-9.54	25.69	Avg.	54	-28.31
17.235	V	46.31	34.01	32.19	10.17	-9.54	45.12	Peak	74	-28.88
17.235	V	31.75	34.01	32.19	10.17	-9.54	30.56	Avg.	54	-23.44

Table 38. Radiated Harmonics, 802.11a, 16 dBi Sector, 5745 MHz

Note: All other emissions were measured at the noise floor of the spectrum analyzer.

Freq. (GHz)	Antenna Polarity (H/V)	Raw Amp. @ 3 m (Peak) / (Avg.)	P. Amp (dB)	Ant. Cor. Factor (dB/m)	Cable Loss (dB)	Distance Correction Factor 1m to 3m (dBuV/m)	EUT Field Strength Final Amp. (dBuV/m)	Limit Detector Peak / Avg. (Peak) / (Avg.)	Limit @ 3 m (dBuV/m)	Delta (dB)
11.57	V	45.94	34.91	30.50	7.63	-9.54	39.62	Peak	74	-34.38
11.57	V	31.39	34.91	30.50	7.63	-9.54	25.07	Avg.	54	-28.93
17.355	V	45.94	33.93	32.15	10.33	-9.54	44.95	Peak	74	-29.05
17.355	V	31.84	33.93	32.15	10.33	-9.54	30.85	Avg.	54	-23.15

Table 39. Radiated Harmonics, 802.11a, 16 dBi Sector, 5785 MHz

Note: All other emissions were measured at the noise floor of the spectrum analyzer.

Freq. (GHz)	Antenna Polarity (H/V)	Raw Amp. @ 3 m (Peak) / (Avg.)	P. Amp (dB)	Ant. Cor. Factor (dB/m)	Cable Loss (dB)	Distance Correction Factor 1m to 3m (dBuV/m)	EUT Field Strength Final Amp. (dBuV/m)	Limit Detector Peak / Avg. (Peak) / (Avg.)	Limit @ 3 m (dBuV/m)	Delta (dB)
11.61	V	45.89	34.93	30.53	7.54	-9.54	39.49	Peak	74	-34.51
11.61	V	31.86	34.93	30.53	7.54	-9.54	25.46	Avg.	54	-28.54
17.415	V	44.87	33.91	32.14	10.42	-9.54	43.99	Peak	74	-30.01
17.415	V	31.16	33.91	32.14	10.42	-9.54	30.28	Avg.	54	-23.72

Table 40. Radiated Harmonics, 802.11a, 16 dBi Sector, 5805 MHz

Note: All other emissions were measured at the noise floor of the spectrum analyzer.

Freq. (GHz)	Antenna Polarity (H/V)	Raw Amp. @ 3 m (Peak) / (Avg.)	P. Amp (dB)	Ant. Cor. Factor (dB/m)	Cable Loss (dB)	Distance Correction Factor 1m to 3m (dBuV/m)	EUT Field Strength Final Amp. (dBuV/m)	Limit Detector Peak / Avg. (Peak) / (Avg.)	Limit @ 3 m (dBuV/m)	Delta (dB)
11.49	V	45.53	34.86	30.43	7.72	-9.54	39.28	Peak	74	-34.72
11.49	V	32.23	34.86	30.43	7.72	-9.54	25.98	Avg.	54	-28.02
17.235	V	45.41	34.01	32.19	10.17	-9.54	44.22	Peak	74	-29.78
17.235	V	31.58	34.01	32.19	10.17	-9.54	30.39	Avg.	54	-23.61

Table 41. Radiated Harmonics, 802.11a, 19 dBi Panel, 5745 MHz

Note: All other emissions were measured at the noise floor of the spectrum analyzer.

Freq. (GHz)	Antenna Polarity (H/V)	Raw Amp. @ 3 m (Peak) / (Avg.)	P. Amp (dB)	Ant. Cor. Factor (dB/m)	Cable Loss (dB)	Distance Correction Factor 1m to 3m (dBuV/m)	EUT Field Strength Final Amp. (dBuV/m)	Limit Detector Peak / Avg. (Peak) / (Avg.)	Limit @ 3 m (dBuV/m)	Delta (dB)
11.57	V	45.29	34.91	30.50	7.63	-9.54	38.97	Peak	74	-35.03
11.57	V	31.29	34.91	30.50	7.63	-9.54	24.97	Avg.	54	-29.03
17.355	V	44.85	33.93	32.15	10.33	-9.54	43.86	Peak	74	-30.14
17.355	V	31.02	33.93	32.15	10.33	-9.54	30.03	Avg.	54	-23.97

Table 42. Radiated Harmonics, 802.11a, 19 dBi Panel, 5785 MHz

Note: All other emissions were measured at the noise floor of the spectrum analyzer.

Freq. (GHz)	Antenna Polarity (H/V)	Raw Amp. @ 3 m (Peak) / (Avg.)	P. Amp (dB)	Ant. Cor. Factor (dB/m)	Cable Loss (dB)	Distance Correction Factor 1m to 3m (dBuV/m)	EUT Field Strength Final Amp. (dBuV/m)	Limit Detector Peak / Avg. (Peak) / (Avg.)	Limit @ 3 m (dBuV/m)	Delta (dB)
11.61	V	47.38	34.93	30.53	7.54	-9.54	40.98	Peak	74	-33.02
11.61	V	33.02	34.93	30.53	7.54	-9.54	26.62	Avg.	54	-27.38
17.415	V	44.11	33.91	32.14	10.42	-9.54	43.23	Peak	74	-30.77
17.415	V	31.93	33.91	32.14	10.42	-9.54	31.05	Avg.	54	-22.95

Table 43. Radiated Harmonics, 802.11a, 19 dBi Panel, 5805 MHz

Note: All other emissions were measured at the noise floor of the spectrum analyzer.

Harmonic Emissions Requirements – Radiated (802.11n 20MHz)

Freq. (GHz)	Antenna Polarity (H/V)	Raw Amp. @ 3 m (Peak) / (Avg.)	P. Amp (dB)	Ant. Cor. Factor (dB/m)	Cable Loss (dB)	Distance Correction Factor 1m to 3m (dBuV/m)	EUT Field Strength Final Amp. (dBuV/m)	Limit Detector Peak / Avg. (Peak) / (Avg.)	Limit @ 3 m (dBuV/m)	Delta (dB)
11.49	V	48.03	34.86	30.43	7.72	-9.54	41.78	Peak	74	-32.22
11.49	V	33.59	34.86	30.43	7.72	-9.54	27.34	Avg.	54	-26.66
17.235	V	45.08	34.01	32.19	10.17	-9.54	43.89	Peak	74	-30.11
17.235	V	32.23	34.01	32.19	10.17	-9.54	31.04	Avg.	54	-22.96

Table 44. Radiated Harmonics, 802.11n 20MHz, 5 dBi Omni, 5745 MHz

Note: All other emissions were measured at the noise floor of the spectrum analyzer.

Freq. (GHz)	Antenna Polarity (H/V)	Raw Amp. @ 3 m (Peak) / (Avg.)	P. Amp (dB)	Ant. Cor. Factor (dB/m)	Cable Loss (dB)	Distance Correction Factor 1m to 3m (dBuV/m)	EUT Field Strength Final Amp. (dBuV/m)	Limit Detector Peak / Avg. (Peak) / (Avg.)	Limit @ 3 m (dBuV/m)	Delta (dB)
11.57	V	48.33	34.91	30.50	7.63	-9.54	42.01	Peak	74	-31.99
11.57	V	33.84	34.91	30.50	7.63	-9.54	27.52	Avg.	54	-26.48
17.355	V	46.44	33.93	32.15	10.33	-9.54	45.45	Peak	74	-28.55
17.355	V	32.98	33.93	32.15	10.33	-9.54	31.99	Avg.	54	-22.01

Table 45. Radiated Harmonics, 802.11n 20MHz, 5 dBi Omni, 5785 MHz

Note: All other emissions were measured at the noise floor of the spectrum analyzer.

Freq. (GHz)	Antenna Polarity (H/V)	Raw Amp. @ 3 m (Peak) / (Avg.)	P. Amp (dB)	Ant. Cor. Factor (dB/m)	Cable Loss (dB)	Distance Correction Factor 1m to 3m (dBuV/m)	EUT Field Strength Final Amp. (dBuV/m)	Limit Detector Peak / Avg. (Peak) / (Avg.)	Limit @ 3 m (dBuV/m)	Delta (dB)
11.61	V	48.19	34.93	30.53	7.54	-9.54	41.79	Peak	74	-32.21
11.61	V	33.33	34.93	30.53	7.54	-9.54	26.93	Avg.	54	-27.07
17.415	V	47.02	33.91	32.14	10.42	-9.54	46.14	Peak	74	-27.86
17.415	V	32.88	33.91	32.14	10.42	-9.54	32.00	Avg.	54	-22.00

Table 46. Radiated Harmonics, 802.11n 20MHz, 5 dBi Omni, 5805 MHz

Note: All other emissions were measured at the noise floor of the spectrum analyzer.

Freq. (GHz)	Antenna Polarity (H/V)	Raw Amp. @ 3 m (Peak) / (Avg.)	P. Amp (dB)	Ant. Cor. Factor (dB/m)	Cable Loss (dB)	Distance Correction Factor 1m to 3m (dBuV/m)	EUT Field Strength Final Amp. (dBuV/m)	Limit Detector Peak / Avg. (Peak) / (Avg.)	Limit @ 3 m (dBuV/m)	Delta (dB)
11.49	V	44.87	34.86	30.43	7.72	-9.54	38.62	Peak	74	-35.38
11.49	V	32.23	34.86	30.43	7.72	-9.54	25.98	Avg.	54	-28.02
17.235	V	45.25	34.01	32.19	10.17	-9.54	44.06	Peak	74	-29.94
17.235	V	32.51	34.01	32.19	10.17	-9.54	31.32	Avg.	54	-22.68

Table 47. Radiated Harmonics, 802.11n 20MHz, 9 dBi Omni, 5745 MHz

Note: All other emissions were measured at the noise floor of the spectrum analyzer.

Freq. (GHz)	Antenna Polarity (H/V)	Raw Amp. @ 3 m (Peak) / (Avg.)	P. Amp (dB)	Ant. Cor. Factor (dB/m)	Cable Loss (dB)	Distance Correction Factor 1m to 3m (dBuV/m)	EUT Field Strength Final Amp. (dBuV/m)	Limit Detector Peak / Avg. (Peak) / (Avg.)	Limit @ 3 m (dBuV/m)	Delta (dB)
11.57	V	45.32	34.91	30.50	7.63	-9.54	39.00	Peak	74	-35.00
11.57	V	32.45	34.91	30.50	7.63	-9.54	26.13	Avg.	54	-27.87
17.355	V	45.98	33.93	32.15	10.33	-9.54	44.99	Peak	74	-29.01
17.355	V	32.47	33.93	32.15	10.33	-9.54	31.48	Avg.	54	-22.52

Table 48. Radiated Harmonics, 802.11n 20MHz, 9 dBi Omni, 5785 MHz

Note: All other emissions were measured at the noise floor of the spectrum analyzer.

Freq. (GHz)	Antenna Polarity (H/V)	Raw Amp. @ 3 m (Peak) / (Avg.)	P. Amp (dB)	Ant. Cor. Factor (dB/m)	Cable Loss (dB)	Distance Correction Factor 1m to 3m (dBuV/m)	EUT Field Strength Final Amp. (dBuV/m)	Limit Detector Peak / Avg. (Peak) / (Avg.)	Limit @ 3 m (dBuV/m)	Delta (dB)
11.61	V	45.24	34.93	30.53	7.54	-9.54	38.84	Peak	74	-35.16
11.61	V	32.45	34.93	30.53	7.54	-9.54	26.05	Avg.	54	-27.95
17.415	V	46.32	33.91	32.14	10.42	-9.54	45.44	Peak	74	-28.56
17.415	V	32.3	33.91	32.14	10.42	-9.54	31.42	Avg.	54	-22.58

Table 49. Radiated Harmonics, 802.11n 20MHz, 9 dBi Omni, 5805 MHz

Note: All other emissions were measured at the noise floor of the spectrum analyzer.

Freq. (GHz)	Antenna Polarity (H/V)	Raw Amp. @ 3 m (Peak) / (Avg.)	P. Amp (dB)	Ant. Cor. Factor (dB/m)	Cable Loss (dB)	Distance Correction Factor 1m to 3m (dBuV/m)	EUT Field Strength Final Amp. (dBuV/m)	Limit Detector Peak / Avg. (Peak) / (Avg.)	Limit @ 3 m (dBuV/m)	Delta (dB)
11.49	V	45.62	34.86	30.43	7.72	-9.54	39.37	Peak	74	-34.63
11.49	V	32.02	34.86	30.43	7.72	-9.54	25.77	Avg.	54	-28.23
17.235	V	45.11	34.01	32.19	10.17	-9.54	43.92	Peak	74	-30.08
17.235	V	31.35	34.01	32.19	10.17	-9.54	30.16	Avg.	54	-23.84

Table 50. Radiated Harmonics, 802.11n 20MHz, 16 dBi Sector, 5745 MHz

Note: All other emissions were measured at the noise floor of the spectrum analyzer.

Freq. (GHz)	Antenna Polarity (H/V)	Raw Amp. @ 3 m (Peak) / (Avg.)	P. Amp (dB)	Ant. Cor. Factor (dB/m)	Cable Loss (dB)	Distance Correction Factor 1m to 3m (dBuV/m)	EUT Field Strength Final Amp. (dBuV/m)	Limit Detector Peak / Avg. (Peak) / (Avg.)	Limit @ 3 m (dBuV/m)	Delta (dB)
11.57	V	46.22	34.91	30.50	7.63	-9.54	39.90	Peak	74	-34.10
11.57	V	31.98	34.91	30.50	7.63	-9.54	25.66	Avg.	54	-28.34
17.355	V	45.82	33.93	32.15	10.33	-9.54	44.83	Peak	74	-29.17
17.355	V	31.87	33.93	32.15	10.33	-9.54	30.88	Avg.	54	-23.12

Table 51. Radiated Harmonics, 802.11n 20MHz, 16 dBi Sector, 5785 MHz

Note: All other emissions were measured at the noise floor of the spectrum analyzer.

Freq. (GHz)	Antenna Polarity (H/V)	Raw Amp. @ 3 m (Peak) / (Avg.)	P. Amp (dB)	Ant. Cor. Factor (dB/m)	Cable Loss (dB)	Distance Correction Factor 1m to 3m (dBuV/m)	EUT Field Strength Final Amp. (dBuV/m)	Limit Detector Peak / Avg. (Peak) / (Avg.)	Limit @ 3 m (dBuV/m)	Delta (dB)
11.61	V	43.55	34.93	30.53	7.54	-9.54	37.15	Peak	74	-36.85
11.61	V	30.98	34.93	30.53	7.54	-9.54	24.58	Avg.	54	-29.42
17.415	V	44.57	33.91	32.14	10.42	-9.54	43.69	Peak	74	-30.31
17.415	V	31.68	33.91	32.14	10.42	-9.54	30.80	Avg.	54	-23.20

Table 52. Radiated Harmonics, 802.11n 20MHz, 16 dBi Sector, 5805 MHz

Note: All other emissions were measured at the noise floor of the spectrum analyzer.

Freq. (GHz)	Antenna Polarity (H/V)	Raw Amp. @ 3 m (Peak) / (Avg.)	P. Amp (dB)	Ant. Cor. Factor (dB/m)	Cable Loss (dB)	Distance Correction Factor 1m to 3m (dBuV/m)	EUT Field Strength Final Amp. (dBuV/m)	Limit Detector Peak / Avg. (Peak) / (Avg.)	Limit @ 3 m (dBuV/m)	Delta (dB)
11.49	V	47.33	34.86	30.43	7.72	-9.54	41.08	Peak	74	-32.92
11.49	V	32.84	34.86	30.43	7.72	-9.54	26.59	Avg.	54	-27.41
17.235	V	45.21	34.01	32.19	10.17	-9.54	44.02	Peak	74	-29.98
17.235	V	31.72	34.01	32.19	10.17	-9.54	30.53	Avg.	54	-23.47

Table 53. Radiated Harmonics, 802.11n 20MHz, 19 dBi Panel, 5745 MHz

Note: All other emissions were measured at the noise floor of the spectrum analyzer.

Freq. (GHz)	Antenna Polarity (H/V)	Raw Amp. @ 3 m (Peak) / (Avg.)	P. Amp (dB)	Ant. Cor. Factor (dB/m)	Cable Loss (dB)	Distance Correction Factor 1m to 3m (dBuV/m)	EUT Field Strength Final Amp. (dBuV/m)	Limit Detector Peak / Avg. (Peak) / (Avg.)	Limit @ 3 m (dBuV/m)	Delta (dB)
11.57	V	45.23	34.91	30.50	7.63	-9.54	38.91	Peak	74	-35.09
11.57	V	32.12	34.91	30.50	7.63	-9.54	25.80	Avg.	54	-28.20
17.355	V	44.45	33.93	32.15	10.33	-9.54	43.46	Peak	74	-30.54
17.355	V	31.74	33.93	32.15	10.33	-9.54	30.75	Avg.	54	-23.25

Table 54. Radiated Harmonics, 802.11n 20MHz, 19 dBi Panel, 5785 MHz

Note: All other emissions were measured at the noise floor of the spectrum analyzer.

Freq. (GHz)	Antenna Polarity (H/V)	Raw Amp. @ 3 m (Peak) / (Avg.)	P. Amp (dB)	Ant. Cor. Factor (dB/m)	Cable Loss (dB)	Distance Correction Factor 1m to 3m (dBuV/m)	EUT Field Strength Final Amp. (dBuV/m)	Limit Detector Peak / Avg. (Peak) / (Avg.)	Limit @ 3 m (dBuV/m)	Delta (dB)
11.61	V	48.49	34.93	30.53	7.54	-9.54	42.09	Peak	74	-31.91
11.61	V	33.34	34.93	30.53	7.54	-9.54	26.94	Avg.	54	-27.06
17.415	V	44.14	33.91	32.14	10.42	-9.54	43.26	Peak	74	-30.74
17.415	V	31.26	33.91	32.14	10.42	-9.54	30.38	Avg.	54	-23.62

Table 55. Radiated Harmonics, 802.11n 20MHz, 19 dBi Panel, 5805 MHz

Note: All other emissions were measured at the noise floor of the spectrum analyzer.

Harmonic Emissions Requirements – Radiated (802.11n 40MHz)

Freq. (GHz)	Antenna Polarity (H/V)	Raw Amp. @ 3 m (Peak) / (Avg.)	P. Amp (dB)	Ant. Cor. Factor (dB/m)	Cable Loss (dB)	Distance Correction Factor 1m to 3m (dBuV/m)	EUT Field Strength Final Amp. (dBuV/m)	Limit Detector Peak / Avg. (Peak) / (Avg.)	Limit @ 3 m (dBuV/m)	Delta (dB)
11.51	V	48.07	34.88	30.44	7.71	-9.54	41.81	Peak	74	-32.19
11.51	V	34.78	34.88	30.44	7.71	-9.54	28.52	Avg.	54	-25.48
17.265	V	44.44	33.98	32.18	10.21	-9.54	43.30	Peak	74	-30.70
17.265	V	32.09	33.98	32.18	10.21	-9.54	30.95	Avg.	54	-23.05

Table 56. Radiated Harmonics, 802.11n 40MHz, 5 dBi Omni, 5755 MHz

Note: All other emissions were measured at the noise floor of the spectrum analyzer.

Freq. (GHz)	Antenna Polarity (H/V)	Raw Amp. @ 3 m (Peak) / (Avg.)	P. Amp (dB)	Ant. Cor. Factor (dB/m)	Cable Loss (dB)	Distance Correction Factor 1m to 3m (dBuV/m)	EUT Field Strength Final Amp. (dBuV/m)	Limit Detector Peak / Avg. (Peak) / (Avg.)	Limit @ 3 m (dBuV/m)	Delta (dB)
11.59	V	48.32	34.92	30.51	7.59	-9.54	41.96	Peak	74	-32.04
11.59	V	34.69	34.92	30.51	7.59	-9.54	28.33	Avg.	54	-25.67
17.385	V	44.21	33.92	32.15	10.38	-9.54	43.27	Peak	74	-30.73
17.385	V	32.54	33.92	32.15	10.38	-9.54	31.60	Avg.	54	-22.40

Table 57. Radiated Harmonics, 802.11n 40MHz, 5 dBi Omni, 5795 MHz

Note: All other emissions were measured at the noise floor of the spectrum analyzer.

Freq. (GHz)	Antenna Polarity (H/V)	Raw Amp. @ 3 m (Peak) / (Avg.)	P. Amp (dB)	Ant. Cor. Factor (dB/m)	Cable Loss (dB)	Distance Correction Factor 1m to 3m (dBuV/m)	EUT Field Strength Final Amp. (dBuV/m)	Limit Detector Peak / Avg. (Peak) / (Avg.)	Limit @ 3 m (dBuV/m)	Delta (dB)
11.51	V	45.32	34.88	30.44	7.71	-9.54	39.06	Peak	74	-34.94
11.51	V	33.02	34.88	30.44	7.71	-9.54	26.76	Avg.	54	-27.24
17.265	V	46.33	33.98	32.18	10.21	-9.54	45.19	Peak	74	-28.81
17.265	V	32.2	33.98	32.18	10.21	-9.54	31.06	Avg.	54	-22.94

Table 58. Radiated Harmonics, 802.11n 40MHz, 9 dBi Omni, 5755 MHz

Note: All other emissions were measured at the noise floor of the spectrum analyzer.

Freq. (GHz)	Antenna Polarity (H/V)	Raw Amp. @ 3 m (Peak) / (Avg.)	P. Amp (dB)	Ant. Cor. Factor (dB/m)	Cable Loss (dB)	Distance Correction Factor 1m to 3m (dBuV/m)	EUT Field Strength Final Amp. (dBuV/m)	Limit Detector Peak / Avg. (Peak) / (Avg.)	Limit @ 3 m (dBuV/m)	Delta (dB)
11.59	V	45.59	34.92	30.51	7.59	-9.54	39.23	Peak	74	-34.77
11.59	V	33.2	34.92	30.51	7.59	-9.54	26.84	Avg.	54	-27.16
17.385	V	46.93	33.92	32.15	10.38	-9.54	45.99	Peak	74	-28.01
17.385	V	33.73	33.92	32.15	10.38	-9.54	32.79	Avg.	54	-21.21

Table 59. Radiated Harmonics, 802.11n 40MHz, 9 dBi Omni, 5795 MHz

Note: All other emissions were measured at the noise floor of the spectrum analyzer.

Freq. (GHz)	Antenna Polarity (H/V)	Raw Amp. @ 3 m (Peak) / (Avg.)	P. Amp (dB)	Ant. Cor. Factor (dB/m)	Cable Loss (dB)	Distance Correction Factor 1m to 3m (dBuV/m)	EUT Field Strength Final Amp. (dBuV/m)	Limit Detector Peak / Avg. (Peak) / (Avg.)	Limit @ 3 m (dBuV/m)	Delta (dB)
11.51	V	43.64	34.88	30.44	7.71	-9.54	37.38	Peak	74	-36.62
11.51	V	30.35	34.88	30.44	7.71	-9.54	24.09	Avg.	54	-29.91
17.265	V	44.85	33.98	32.18	10.21	-9.54	43.71	Peak	74	-30.29
17.265	V	31.03	33.98	32.18	10.21	-9.54	29.89	Avg.	54	-24.11

Table 60. Radiated Harmonics, 802.11n 40MHz, 16 dBi Sector, 5755 MHz

Note: All other emissions were measured at the noise floor of the spectrum analyzer.

Freq. (GHz)	Antenna Polarity (H/V)	Raw Amp. @ 3 m (Peak) / (Avg.)	P. Amp (dB)	Ant. Cor. Factor (dB/m)	Cable Loss (dB)	Distance Correction Factor 1m to 3m (dBuV/m)	EUT Field Strength Final Amp. (dBuV/m)	Limit Detector Peak / Avg. (Peak) / (Avg.)	Limit @ 3 m (dBuV/m)	Delta (dB)
11.59	V	44.42	34.92	30.51	7.59	-9.54	38.06	Peak	74	-35.94
11.59	V	30.93	34.92	30.51	7.59	-9.54	24.57	Avg.	54	-29.43
17.385	V	45.48	33.92	32.15	10.38	-9.54	44.54	Peak	74	-29.46
17.385	V	30.25	33.92	32.15	10.38	-9.54	29.31	Avg.	54	-24.69

Table 61. Radiated Harmonics, 802.11n 40MHz, 16 dBi Sector, 5795 MHz

Note: All other emissions were measured at the noise floor of the spectrum analyzer.

Freq. (GHz)	Antenna Polarity (H/V)	Raw Amp. @ 3 m (Peak) / (Avg.)	P. Amp (dB)	Ant. Cor. Factor (dB/m)	Cable Loss (dB)	Distance Correction Factor 1m to 3m (dBuV/m)	EUT Field Strength Final Amp. (dBuV/m)	Limit Detector Peak / Avg. (Peak) / (Avg.)	Limit @ 3 m (dBuV/m)	Delta (dB)
11.51	V	45.2	34.88	30.44	7.71	-9.54	38.94	Peak	74	-35.06
11.51	V	31.95	34.88	30.44	7.71	-9.54	25.69	Avg.	54	-28.31
17.265	V	45.92	33.98	32.18	10.21	-9.54	44.78	Peak	74	-29.22
17.265	V	31.57	33.98	32.18	10.21	-9.54	30.43	Avg.	54	-23.57

Table 62. Radiated Harmonics, 802.11n 40MHz, 19 dBi Panel, 5755 MHz

Note: All other emissions were measured at the noise floor of the spectrum analyzer.

Freq. (GHz)	Antenna Polarity (H/V)	Raw Amp. @ 3 m (Peak) / (Avg.)	P. Amp (dB)	Ant. Cor. Factor (dB/m)	Cable Loss (dB)	Distance Correction Factor 1m to 3m (dBuV/m)	EUT Field Strength Final Amp. (dBuV/m)	Limit Detector Peak / Avg. (Peak) / (Avg.)	Limit @ 3 m (dBuV/m)	Delta (dB)
11.59	V	45.25	34.92	30.51	7.59	-9.54	38.89	Peak	74	-35.11
11.59	V	31.62	34.92	30.51	7.59	-9.54	25.26	Avg.	54	-28.74
17.385	V	44.45	33.92	32.15	10.38	-9.54	43.51	Peak	74	-30.49
17.385	V	31.66	33.92	32.15	10.38	-9.54	30.72	Avg.	54	-23.28

Table 63. Radiated Harmonics, 802.11n 40MHz, 19 dBi Panel, 5795 MHz

Note: All other emissions were measured at the noise floor of the spectrum analyzer.

§ 15.209 Radiated Emissions Limits, 802.11a

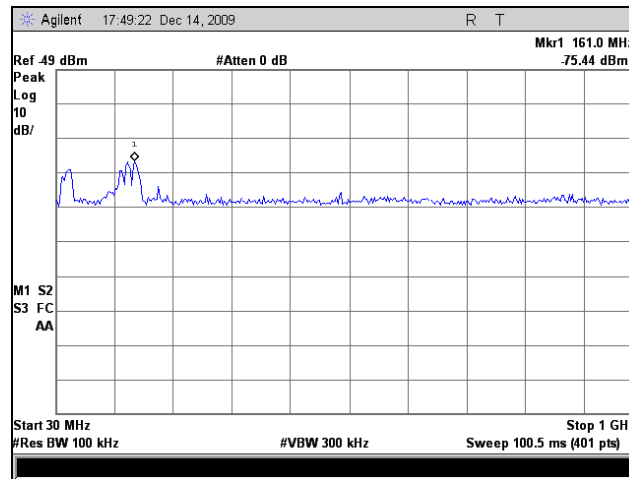

Plot 85. Radiated Spurious, 802.11a, 5745 MHz, 30 MHz – 1 GHz, 5 dBi Omni

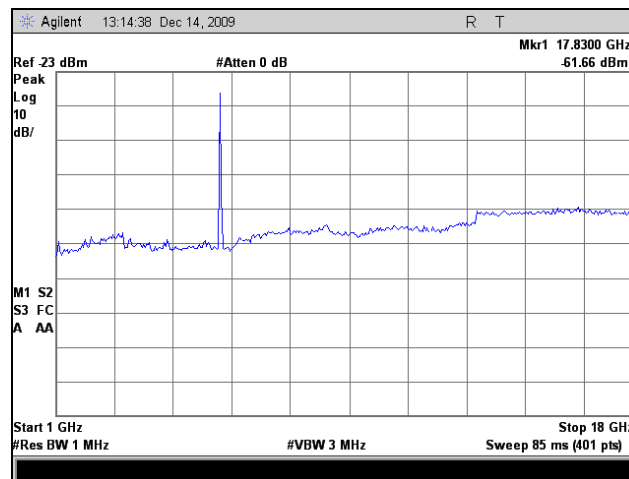

Plot 86. Radiated Spurious, 802.11a, 5745 MHz, 1 GHz – 18 GHz, 5 dBi Omni

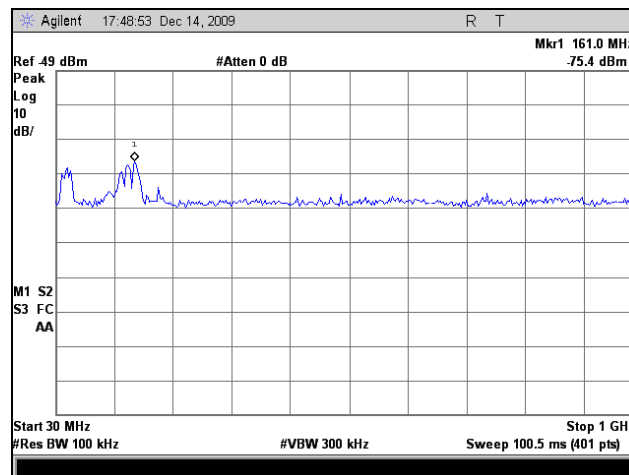

Plot 87. Radiated Spurious, 802.11a, 5785 MHz, 30 MHz – 1 GHz, 5 dBi Omni

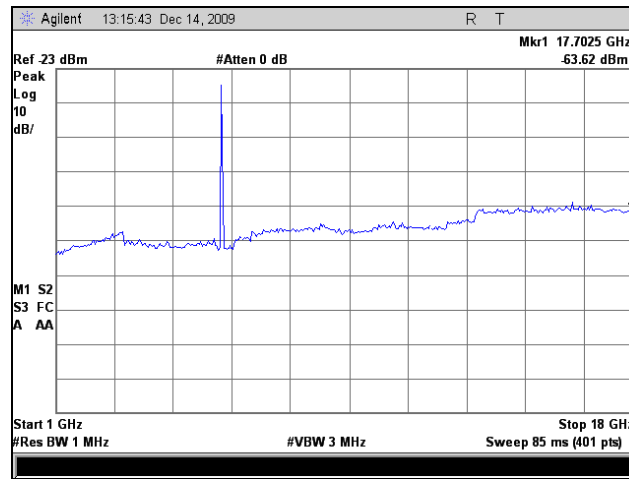

Plot 88. Radiated Spurious, 802.11a, 5785 MHz, 1 GHz – 18 GHz, 5 dBi Omni

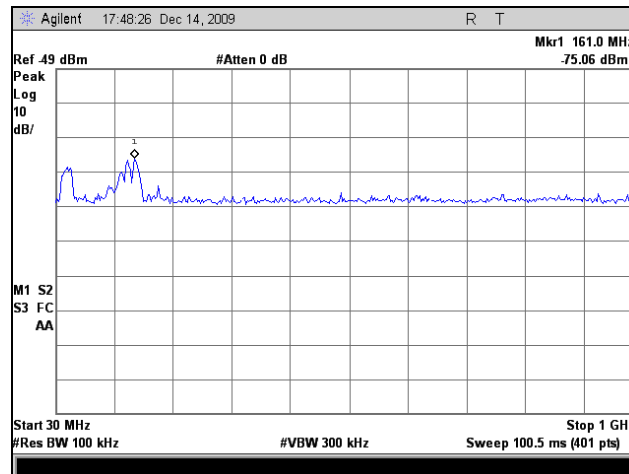

Plot 89. Radiated Spurious, 802.11a, 5805 MHz, 30 MHz – 1 GHz, 5 dBi Omni

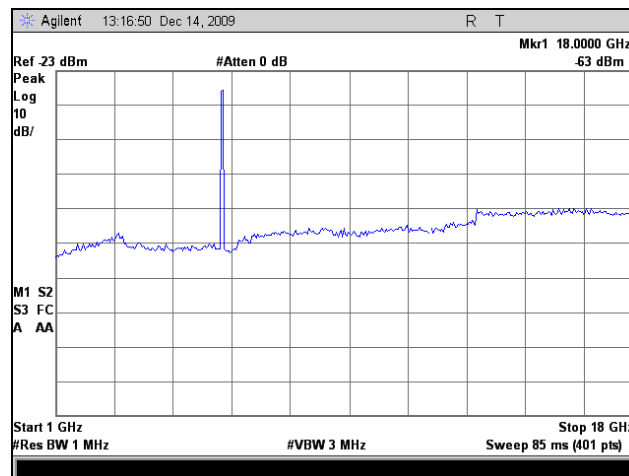

Plot 90. Radiated Spurious, 802.11a, 5805 MHz, 1 GHz – 18 GHz, 5 dBi Omni

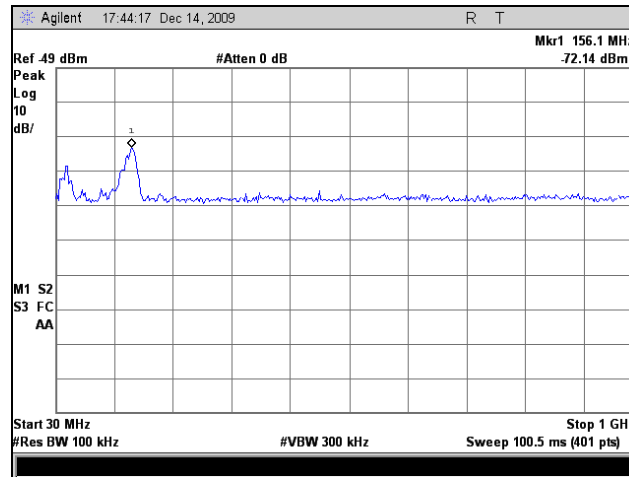

Plot 91. Radiated Spurious, 802.11a, 5745 MHz, 30 MHz – 1 GHz, 9 dBi Omni

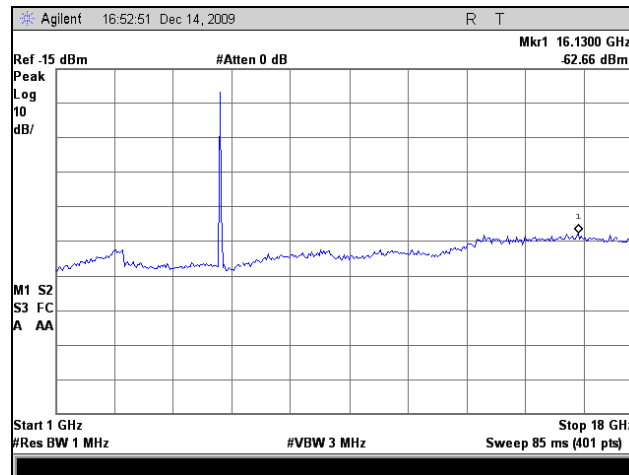

Plot 92. Radiated Spurious, 802.11a, 5745 MHz, 1 GHz – 18 GHz, 9 dBi Omni

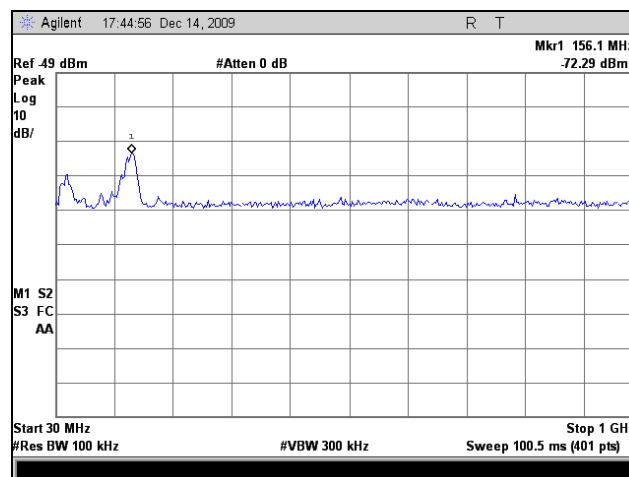

Plot 93. Radiated Spurious, 802.11a, 5785 MHz, 30 MHz – 1 GHz, 9 dBi Omni

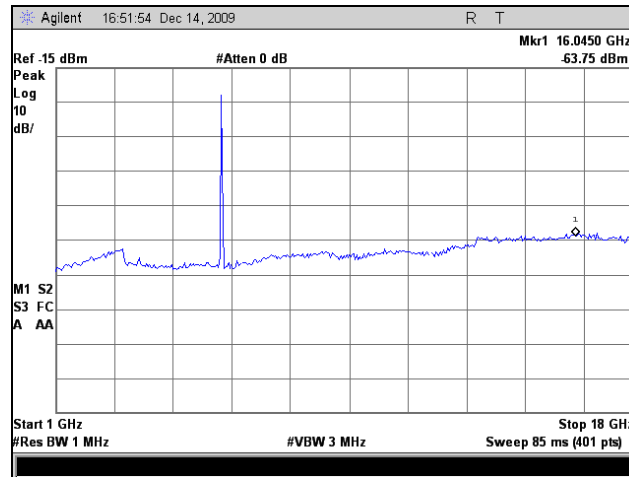

Plot 94. Radiated Spurious, 802.11a, 5785 MHz, 1 GHz – 18 GHz, 9 dBi Omni

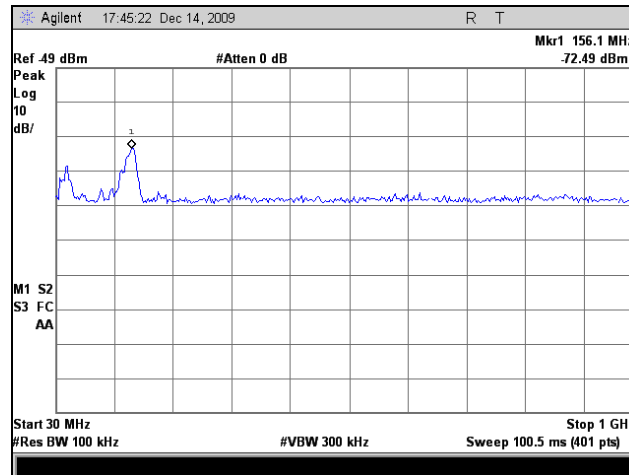

Plot 95. Radiated Spurious, 802.11a, 5805 MHz, 30 MHz – 1 GHz, 9 dBi Omni

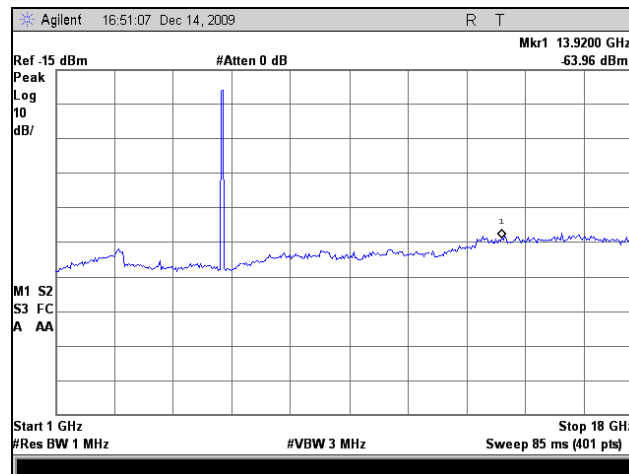

Plot 96. Radiated Spurious, 802.11a, 5805 MHz, 1 GHz – 18 GHz, 9 dBi Omni

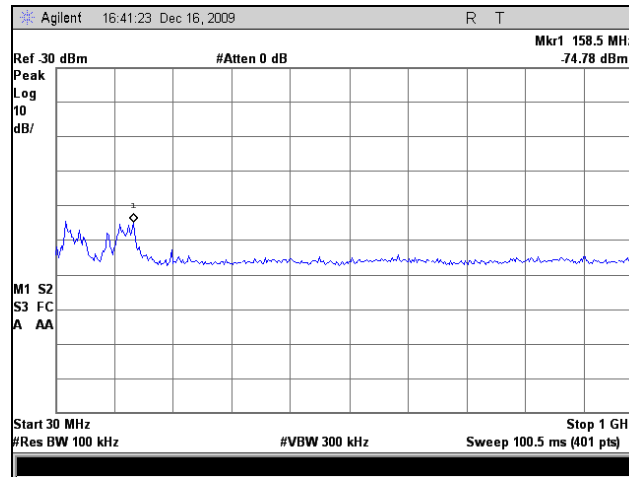

Plot 97. Radiated Spurious, 802.11a, 5745 MHz, 30 MHz – 1 GHz, 16 dBi Sector

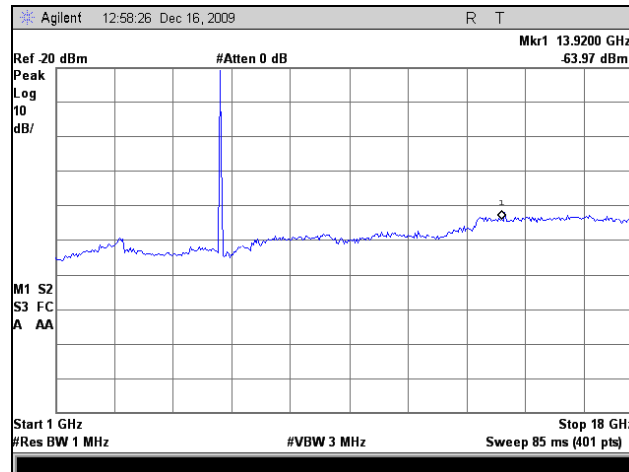

Plot 98. Radiated Spurious, 802.11a, 5745 MHz, 1 GHz – 18 GHz, 16 dBi Sector

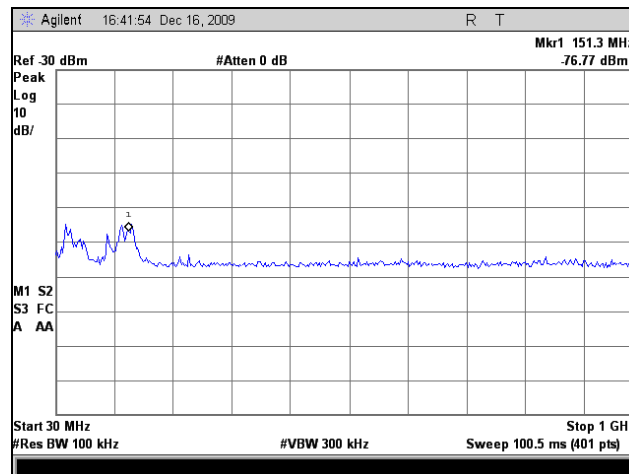

Plot 99. Radiated Spurious, 802.11a, 5785 MHz, 30 MHz – 1 GHz, 16 dBi Sector

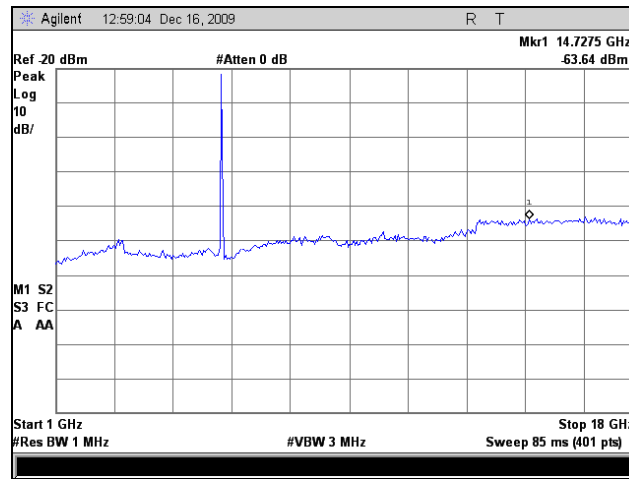

Plot 100. Radiated Spurious, 802.11a, 5785 MHz, 1 GHz – 18 GHz, 16 dBi Sector

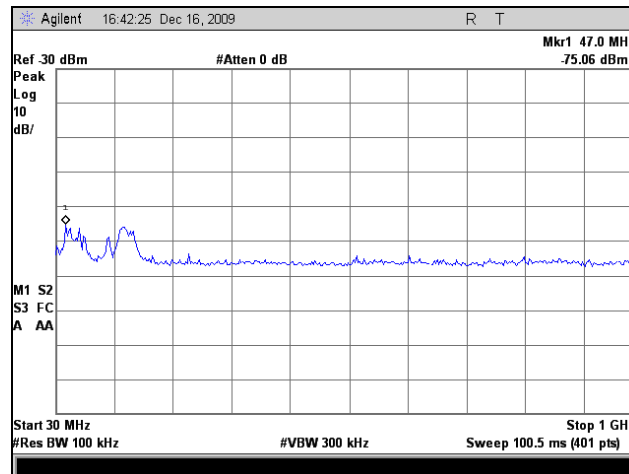

Plot 101. Radiated Spurious, 802.11a, 5805 MHz, 30 MHz – 1 GHz, 16 dBi Sector

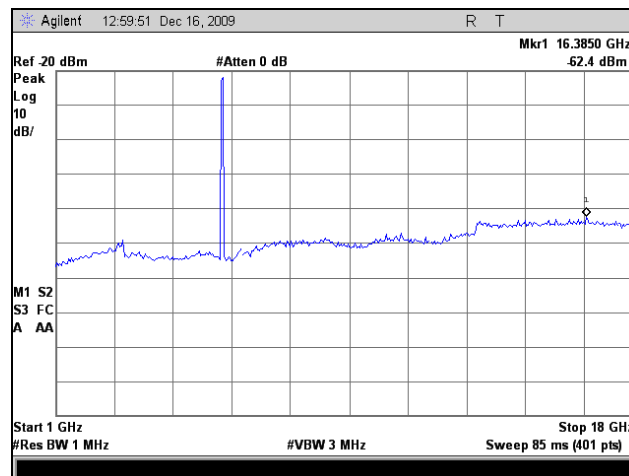

Plot 102. Radiated Spurious, 802.11a, 5805 MHz, 1 GHz – 18 GHz, 16 dBi Sector

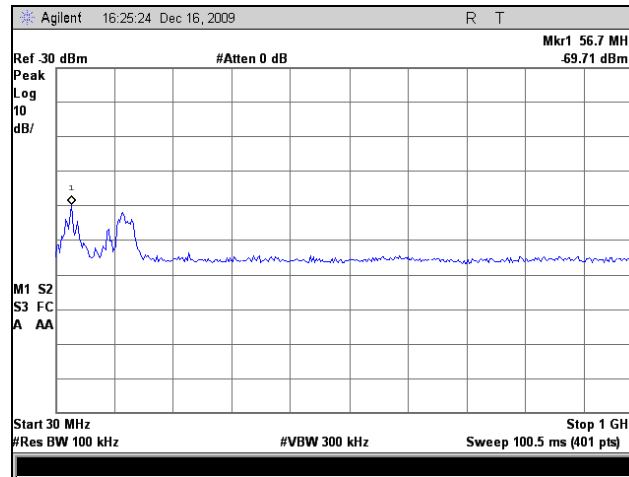

Plot 103. Radiated Spurious, 802.11a, 5745 MHz, 30 MHz – 1 GHz, 19 dBi Panel

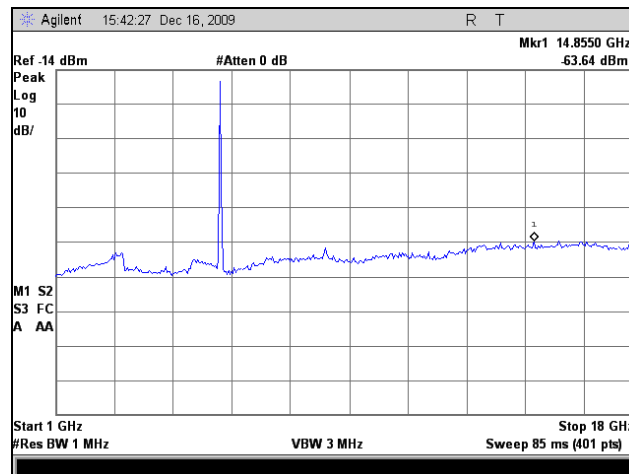

Plot 104. Radiated Spurious, 802.11a, 5745 MHz, 1 GHz – 18 GHz, 19 dBi Panel

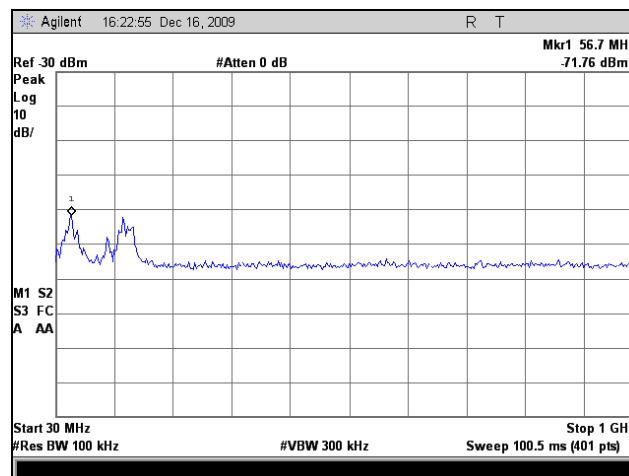

Plot 105. Radiated Spurious, 802.11a, 5785 MHz, 30 MHz – 1 GHz, 19 dBi Panel

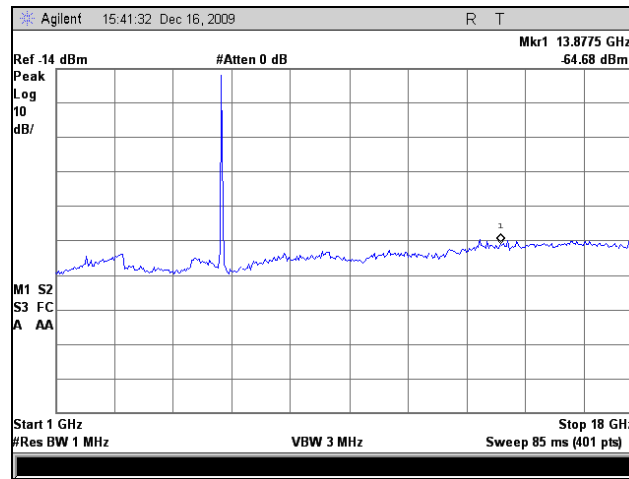

Plot 106. Radiated Spurious, 802.11a, 5785 MHz, 1 GHz – 18 GHz, 19 dBi Panel

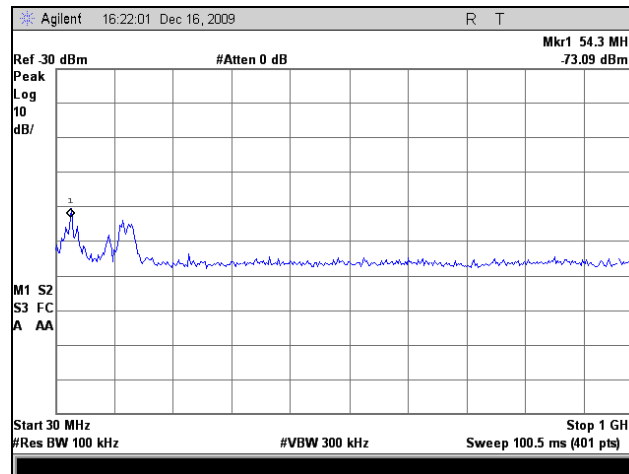

Plot 107. Radiated Spurious, 802.11a, 5805 MHz, 30 MHz – 1 GHz, 19 dBi Panel

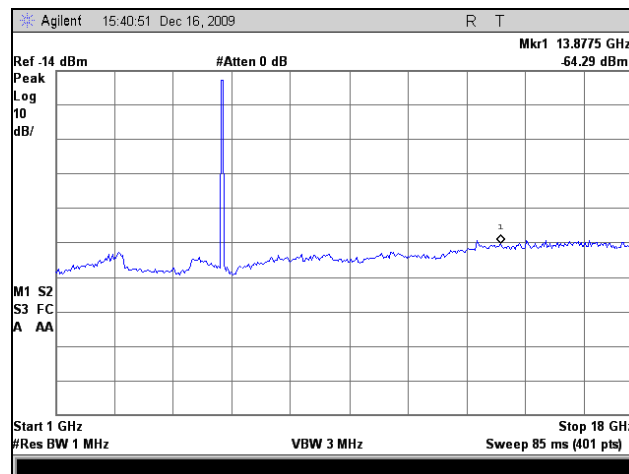

Plot 108. Radiated Spurious, 802.11a, 5805 MHz, 1 GHz – 18 GHz, 19 dBi Panel

§ 15.209 Radiated Emissions Limits, 802.11n 20MHz

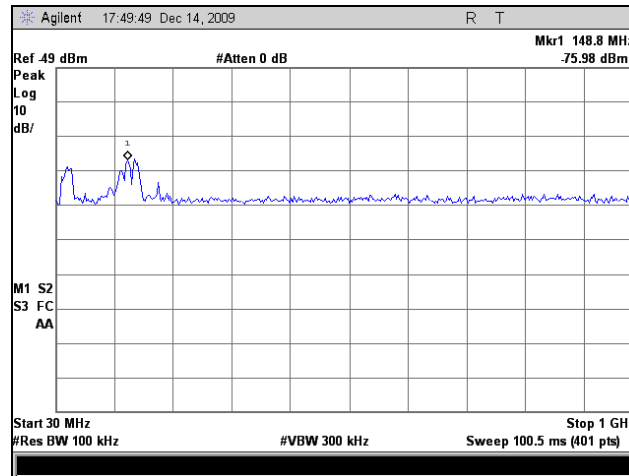

Plot 109. Radiated Spurious, 802.11n 20MHz, 5745 MHz, 30 MHz – 1 GHz, 5 dBi Omni

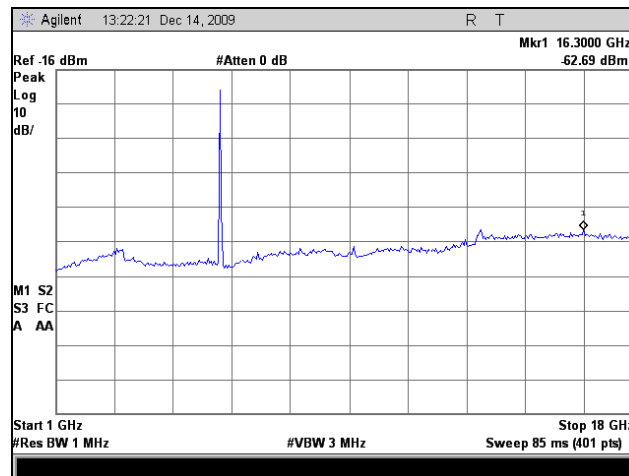

Plot 110. Radiated Spurious, 802.11n 20MHz, 5745 MHz, 1 GHz – 18 GHz, 5 dBi Omni

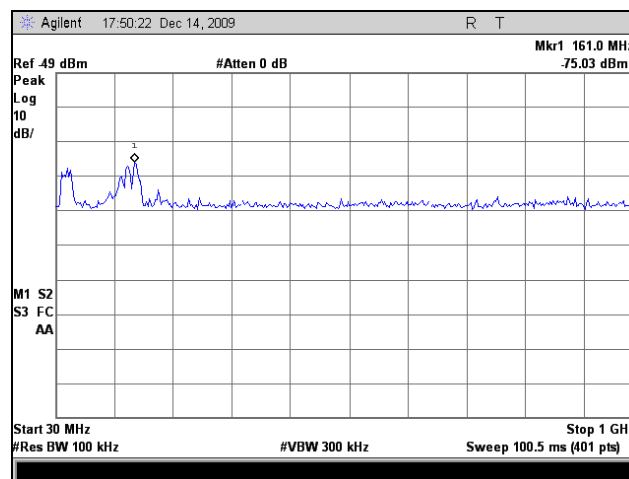

Plot 111. Radiated Spurious, 802.11n 20MHz, 5785 MHz, 30 MHz – 1 GHz, 5 dBi Omni

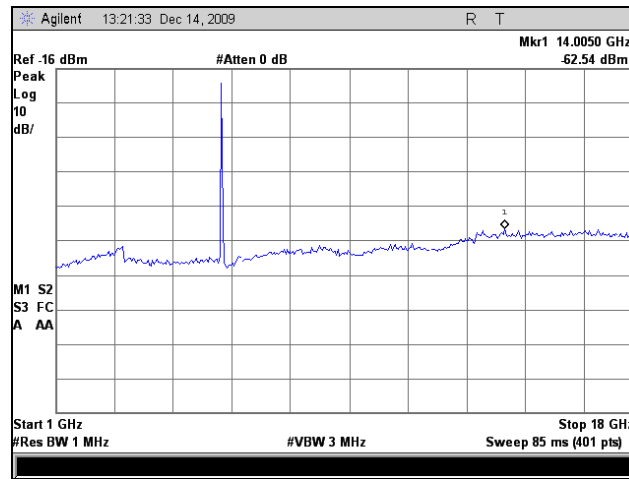

Plot 112. Radiated Spurious, 802.11n 20MHz, 5785 MHz, 1 GHz – 18 GHz, 5 dBi Omni

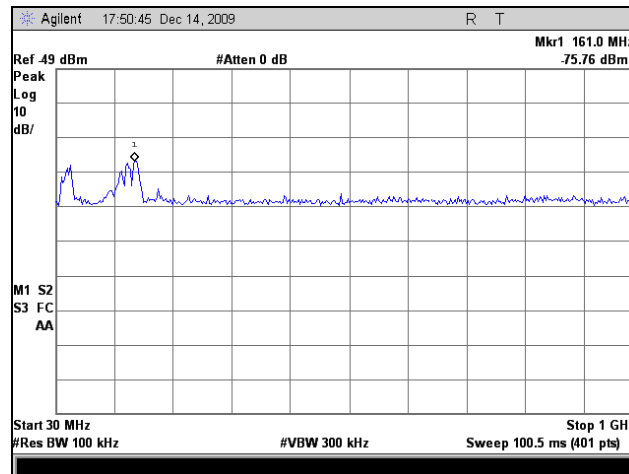

Plot 113. Radiated Spurious, 802.11n 20MHz, 5805 MHz, 30 MHz – 1 GHz, 5 dBi Omni

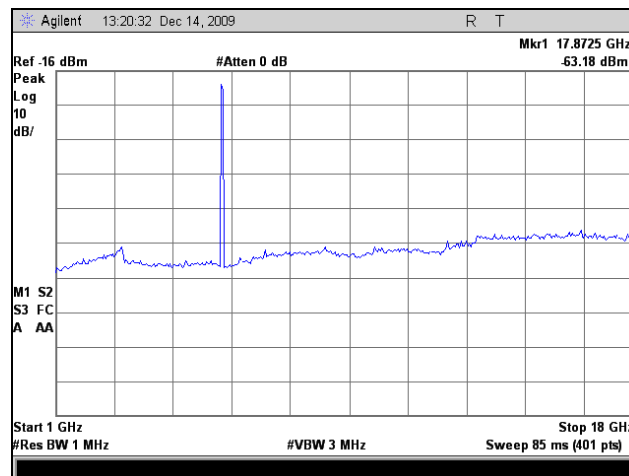

Plot 114. Radiated Spurious, 802.11n 20MHz, 5805 MHz, 1 GHz – 18 GHz, 5 dBi Omni

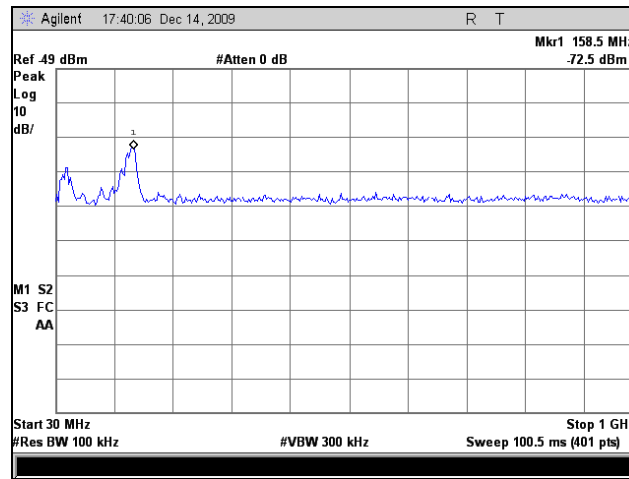

Plot 115. Radiated Spurious, 802.11n 20MHz, 5745 MHz, 30 MHz – 1 GHz, 9 dBi Omni

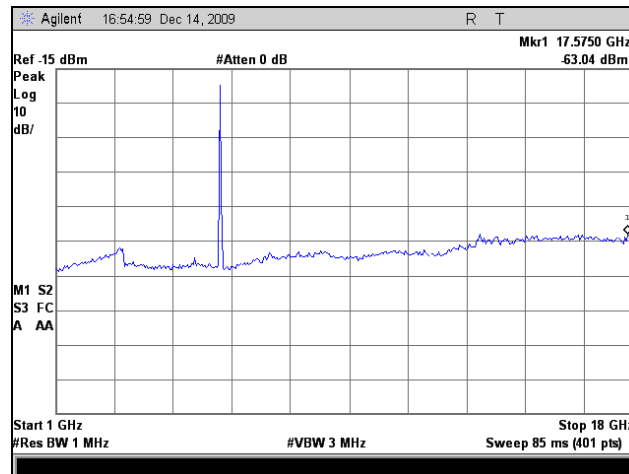

Plot 116. Radiated Spurious, 802.11n 20MHz, 5745 MHz, 1 GHz – 18 GHz, 9 dBi Omni

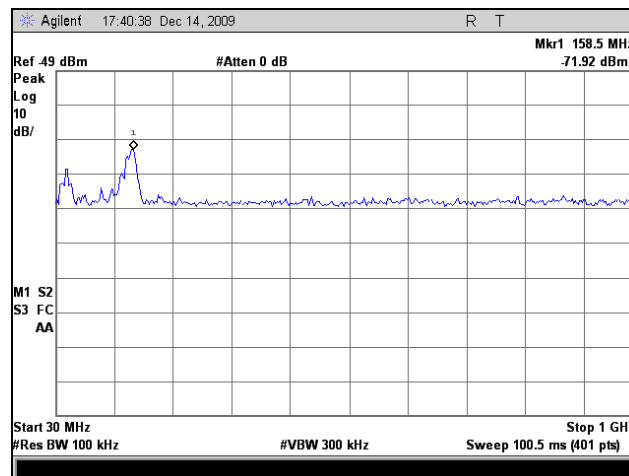

Plot 117. Radiated Spurious, 802.11n 20MHz, 5785 MHz, 30 MHz – 1 GHz, 9 dBi Omni

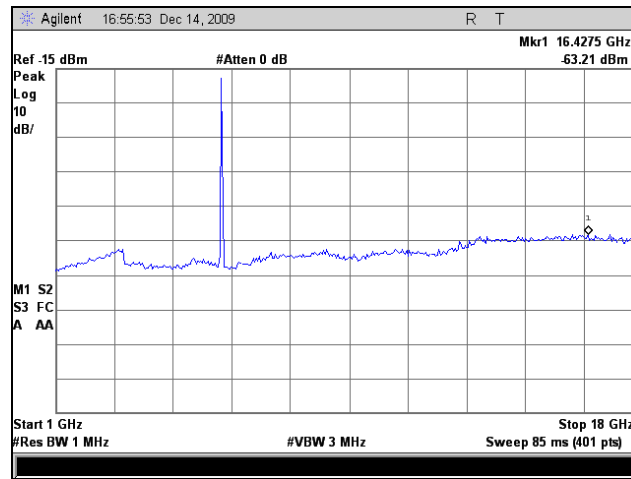

Plot 118. Radiated Spurious, 802.11n 20MHz, 5785 MHz, 1 GHz – 18 GHz, 9 dBi Omni

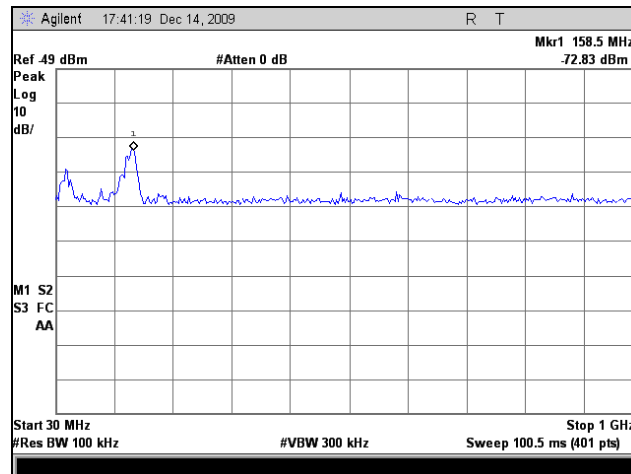

Plot 119. Radiated Spurious, 802.11n 20MHz, 5805 MHz, 30 MHz – 1 GHz, 9 dBi Omni

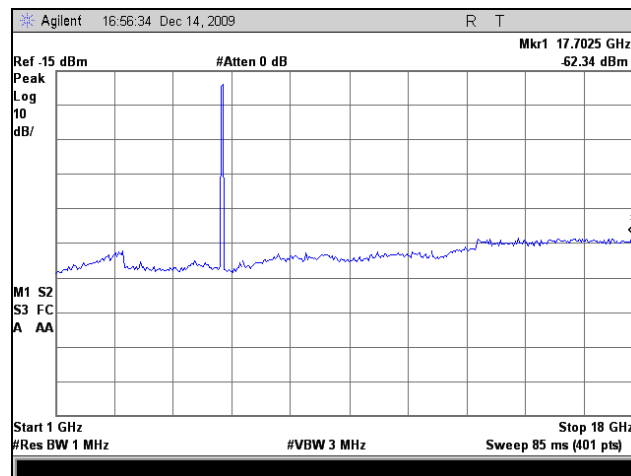

Plot 120. Radiated Spurious, 802.11n 20MHz, 5805 MHz, 1 GHz – 18 GHz, 9 dBi Omni

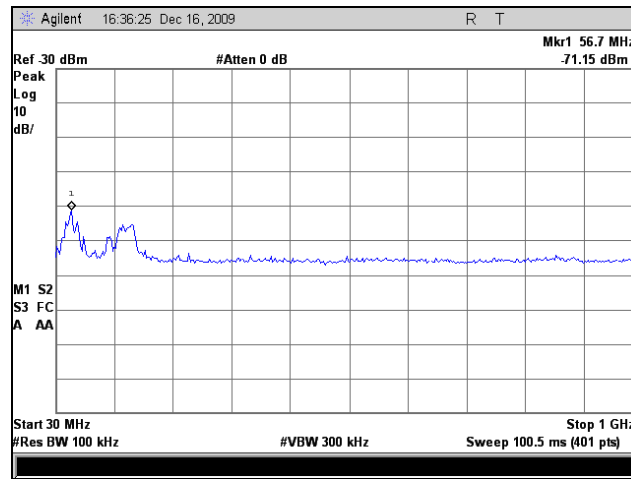

Plot 121. Radiated Spurious, 802.11n 20MHz, 5745 MHz, 30 MHz – 1 GHz, 16 dBi Sector

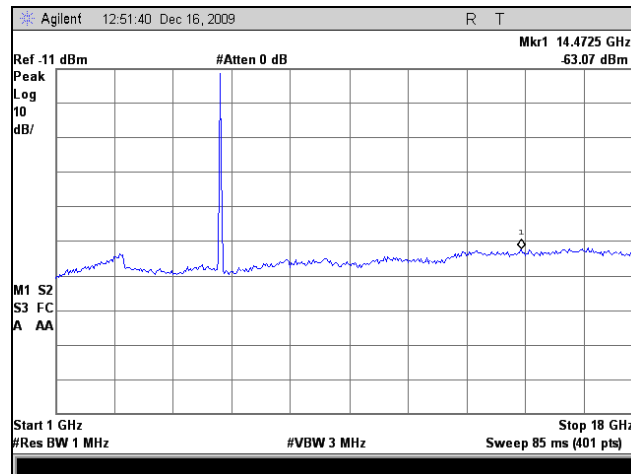

Plot 122. Radiated Spurious, 802.11n 20MHz, 5745 MHz, 1 GHz – 18 GHz, 16 dBi Sector

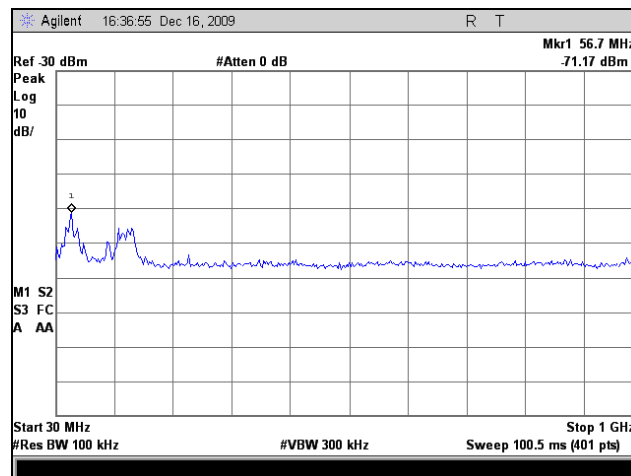

Plot 123. Radiated Spurious, 802.11n 20MHz, 5785 MHz, 30 MHz – 1 GHz, 16 dBi Sector

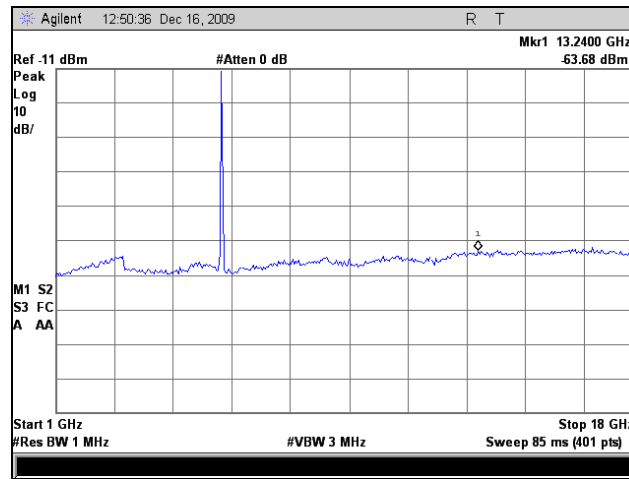

Plot 124. Radiated Spurious, 802.11n 20MHz, 5785 MHz, 1 GHz – 18 GHz, 16 dBi Sector

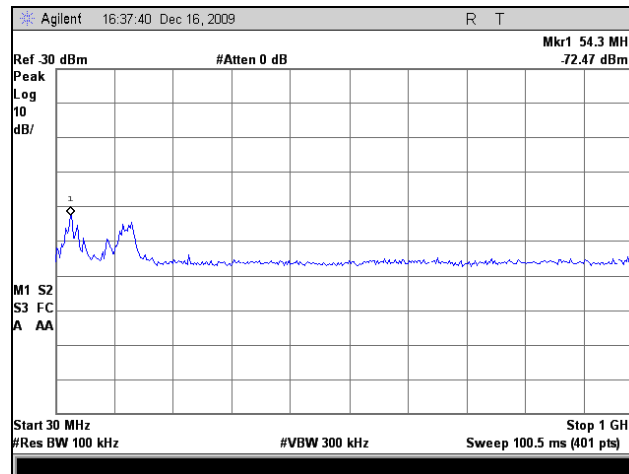

Plot 125. Radiated Spurious, 802.11n 20MHz, 5805 MHz, 30 MHz – 1 GHz, 16 dBi Sector

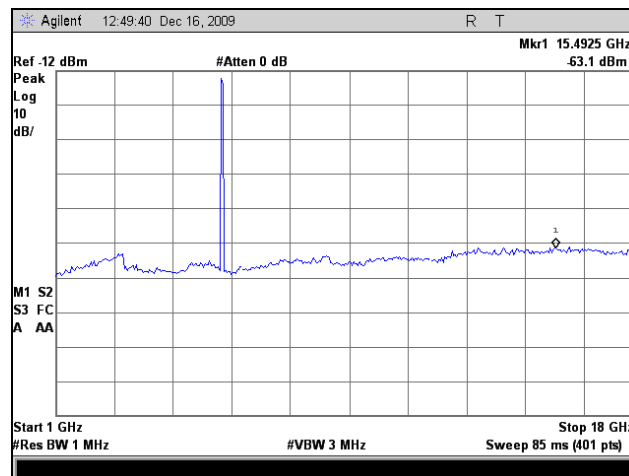

Plot 126. Radiated Spurious, 802.11n 20MHz, 5805 MHz, 1 GHz – 18 GHz, 16 dBi Sector

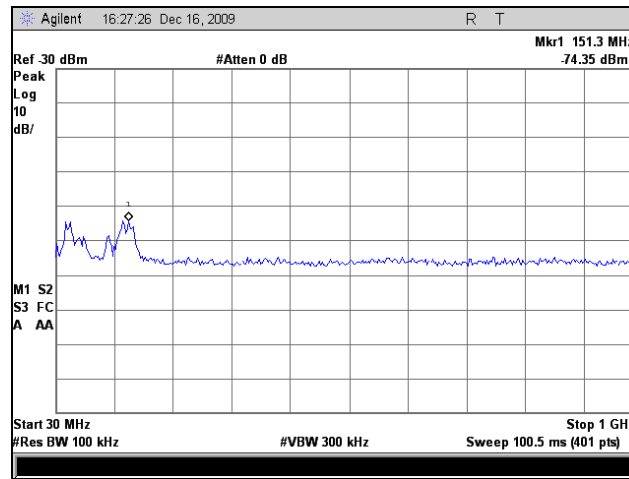

Plot 127. Radiated Spurious, 802.11n 20MHz, 5745 MHz, 30 MHz – 1 GHz, 19 dBi Panel

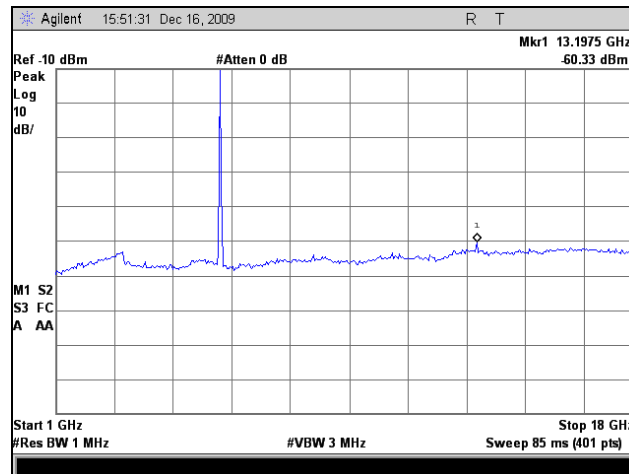

Plot 128. Radiated Spurious, 802.11n 20MHz, 5745 MHz, 1 GHz – 18 GHz, 19 dBi Panel

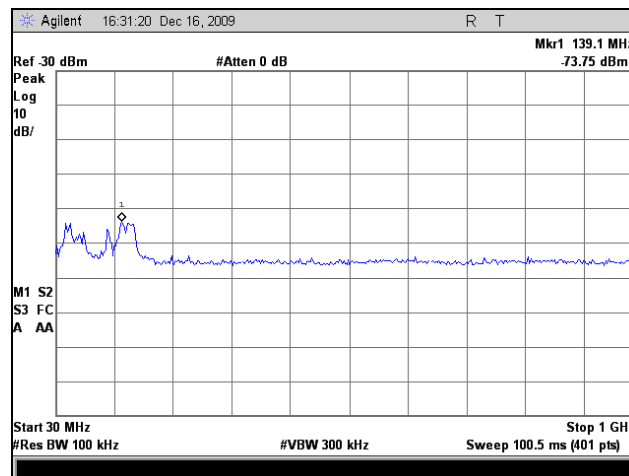

Plot 129. Radiated Spurious, 802.11n 20MHz, 5785 MHz, 30 MHz – 1 GHz, 19 dBi Panel

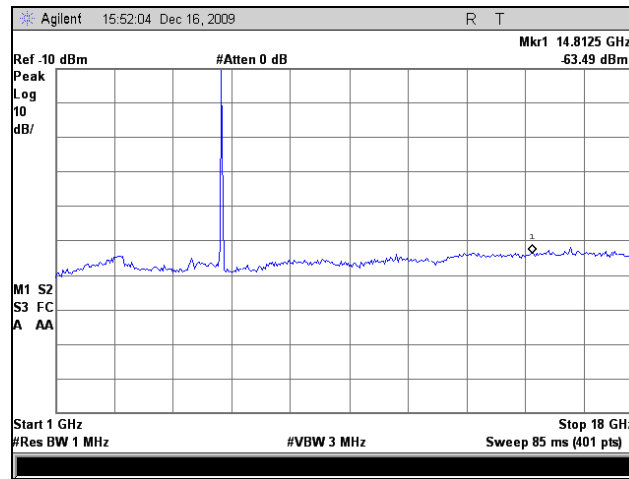

Plot 130. Radiated Spurious, 802.11n 20MHz, 5785 MHz, 1 GHz – 18 GHz, 19 dBi Panel

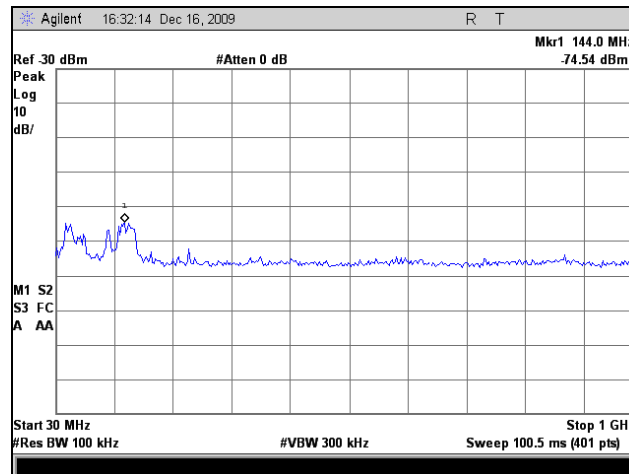

Plot 131. Radiated Spurious, 802.11n 20MHz, 5805 MHz, 30 MHz – 1 GHz, 19 dBi Panel

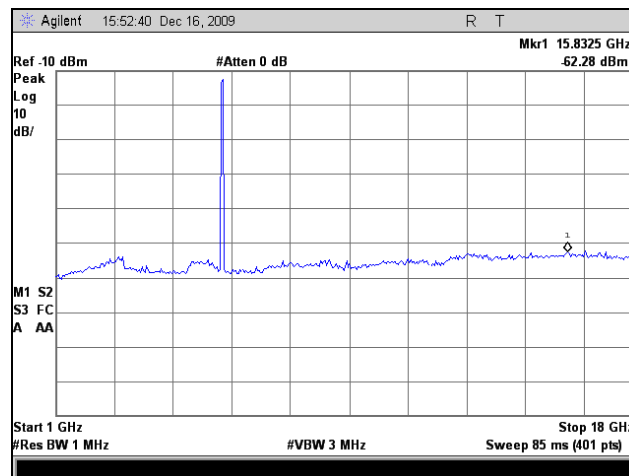

Plot 132. Radiated Spurious, 802.11n 20MHz, 5805 MHz, 1 GHz – 18 GHz, 19 dBi Panel

§ 15.209 Radiated Emissions Limits, 802.11n 40MHz

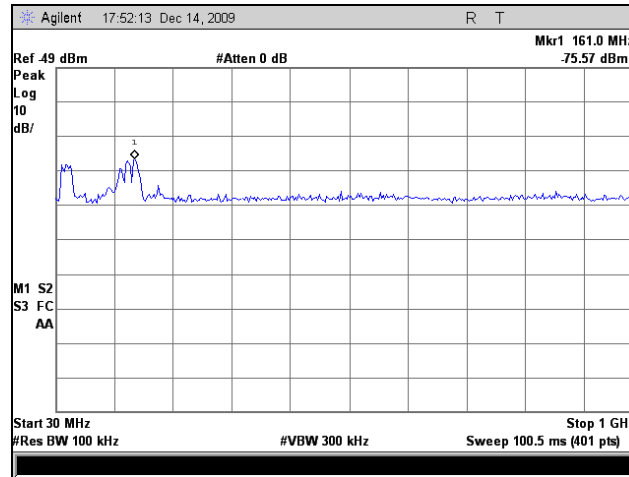

Plot 133. Radiated Spurious, 802.11n 40MHz, 5755 MHz, 30 MHz – 1 GHz, 5 dBi Omni

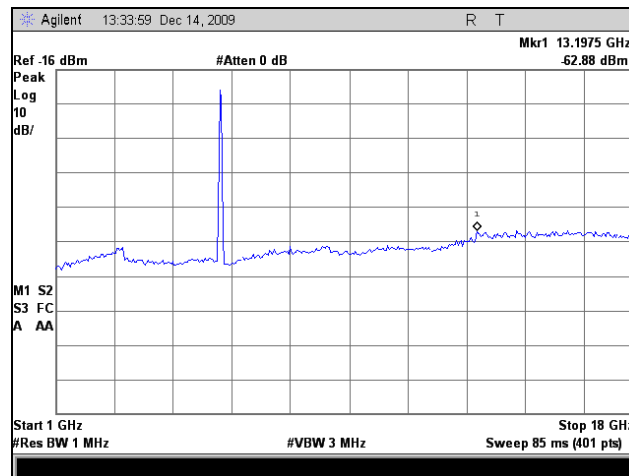

Plot 134. Radiated Spurious, 802.11n 40MHz, 5755 MHz, 1 GHz – 18 GHz, 5 dBi Omni

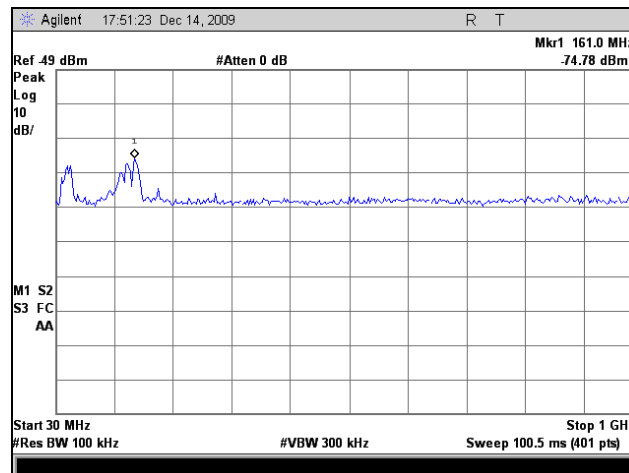

Plot 135. Radiated Spurious, 802.11n 40MHz, 5795 MHz, 30 MHz – 1 GHz, 5 dBi Omni

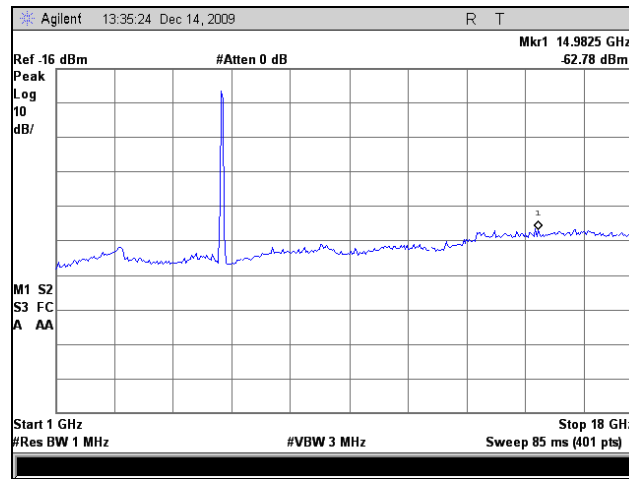

Plot 136. Radiated Spurious, 802.11n 40MHz, 5795 MHz, 1 GHz – 18 GHz, 5 dBi Omni

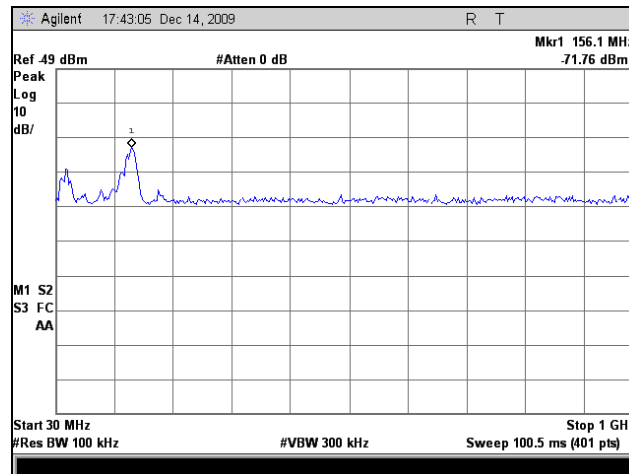

Plot 137. Radiated Spurious, 802.11n 40MHz, 5755 MHz, 30 MHz – 1 GHz, 9 dBi Omni

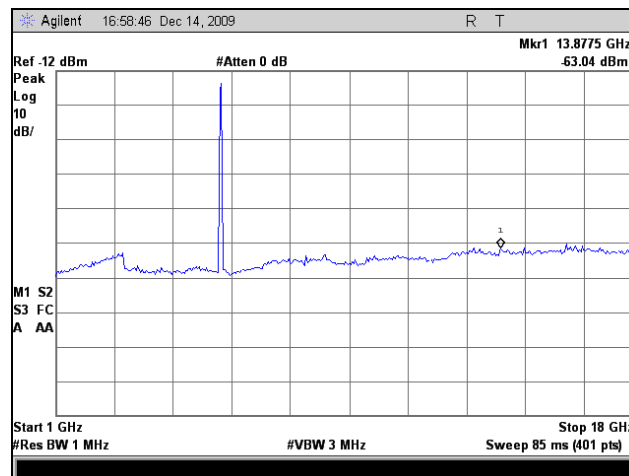

Plot 138. Radiated Spurious, 802.11n 40MHz, 5755 MHz, 1 GHz – 18 GHz, 9 dBi Omni

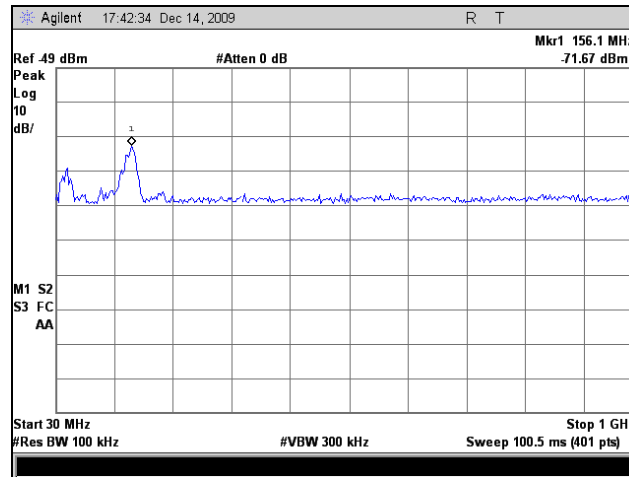

Plot 139. Radiated Spurious, 802.11n 40MHz, 5795 MHz, 30 MHz – 1 GHz, 9 dBi Omni

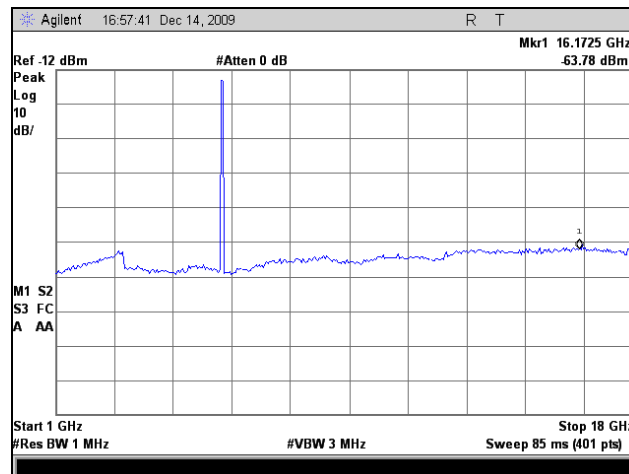

Plot 140. Radiated Spurious, 802.11n 40MHz, 5795 MHz, 1 GHz – 18 GHz, 9 dBi Omni

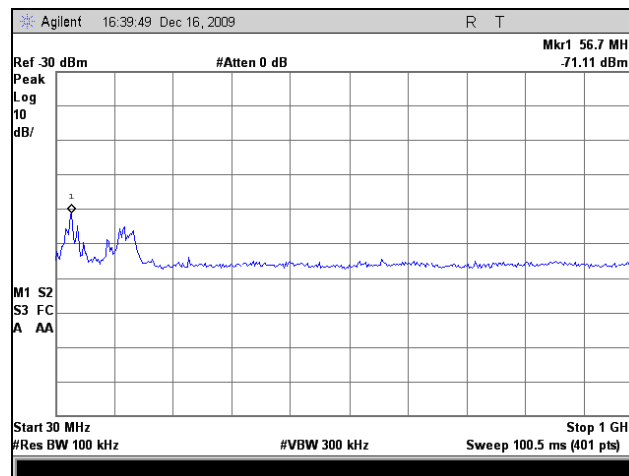

Plot 141. Radiated Spurious, 802.11n 40MHz, 5755 MHz, 30 MHz – 1 GHz, 16 dBi Sector

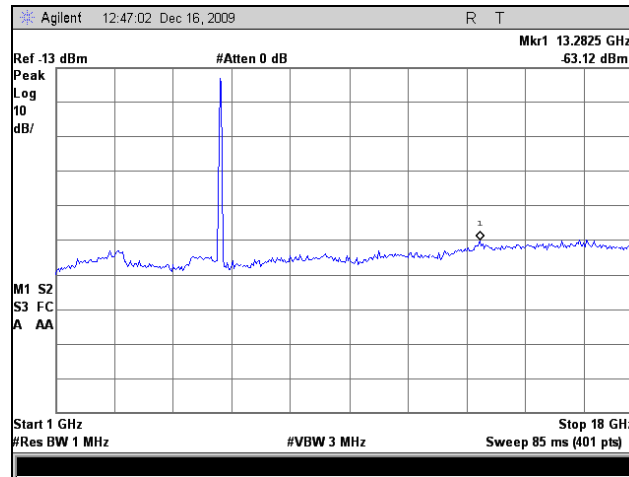

Plot 142. Radiated Spurious, 802.11n 40MHz, 5755 MHz, 1 GHz – 18 GHz, 16 dBi Sector

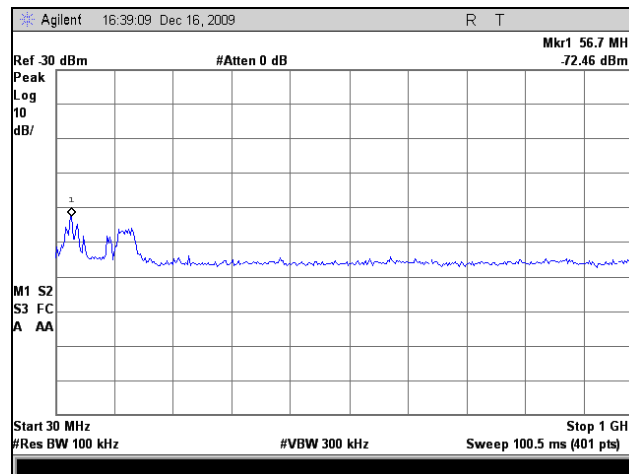

Plot 143. Radiated Spurious, 802.11n 40MHz, 5795 MHz, 30 MHz – 1 GHz, 16 dBi Sector

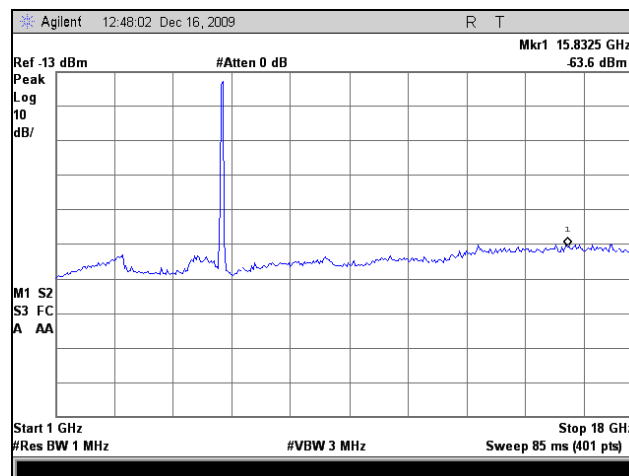

Plot 144. Radiated Spurious, 802.11n 40MHz, 5795 MHz, 1 GHz – 18 GHz, 16 dBi Sector

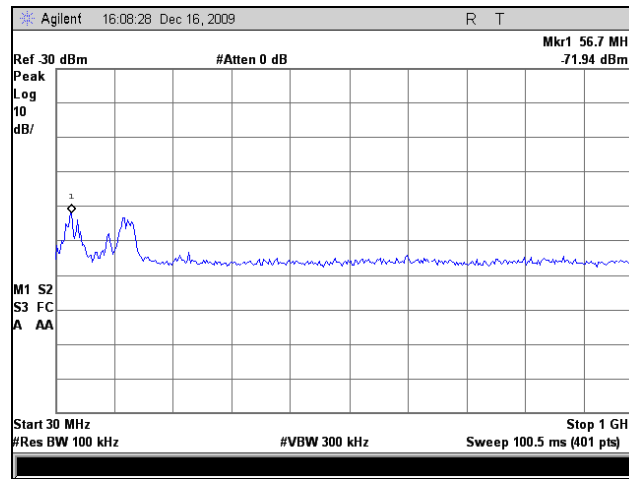

Plot 145. Radiated Spurious, 802.11n 40MHz, 5755 MHz, 30 MHz – 1 GHz, 19 dBi Panel

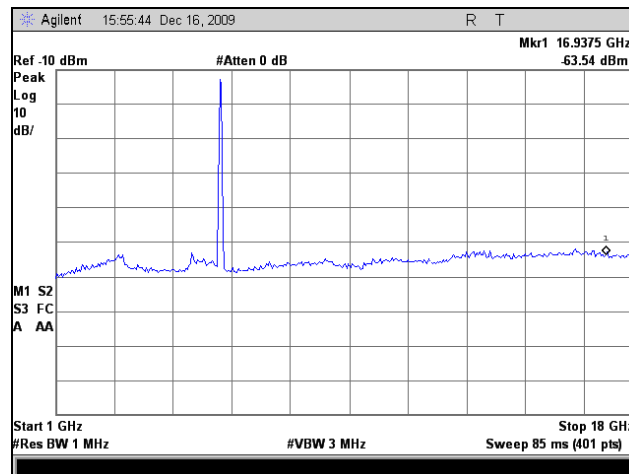

Plot 146. Radiated Spurious, 802.11n 40MHz, 5755 MHz, 1 GHz – 18 GHz, 19 dBi Panel

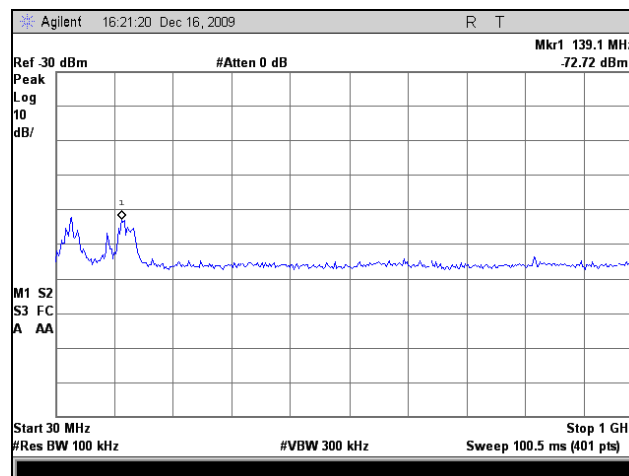

Plot 147. Radiated Spurious, 802.11n 40MHz, 5795 MHz, 30 MHz – 1 GHz, 19 dBi Panel

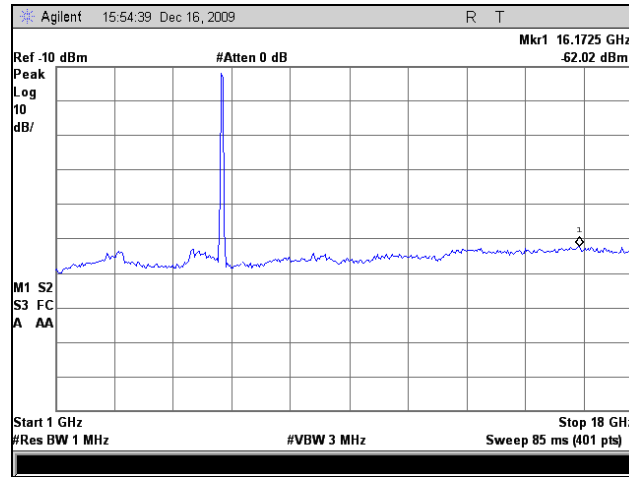

Plot 148. Radiated Spurious, 802.11n 40MHz, 5795 MHz, 1 GHz – 18 GHz, 19 dBi Panel

EIRP

5 dBi Omni Antenna								
a mode	Frequency MHz	Uncorrected Peak (dBuV)	Cable Loss	ACF	DCF	Corrected	Limit (dBuV/m)	Margin
	5745	40.62	7.51	35	9.54	73.59	78.26	-4.67
	5805	42.02	7.83	35	9.54	75.31	78.26	-2.95
HT 20	Frequency MHz	Uncorrected Peak (dBuV)	Cable Loss	ACF	DCF	Corrected	Limit (dBuV/m)	Margin
	5745	44.53	7.51	35	9.54	77.5	78.26	-0.76
	5805	44.01	7.83	35	9.54	77.3	78.26	-0.96
HT 40	Frequency MHz	Uncorrected Peak (dBuV)	Cable Loss	ACF	DCF	Corrected	Limit (dBuV/m)	Margin
	5755	39.7	7.51	35	9.54	72.67	78.26	-5.59
	5795	36.46	7.83	35	9.54	69.75	78.26	-8.51

Table 64. EIRP Calculation, 5 dBi Omni

Note: EIRP Limit -17dBm/MHz = 78.26 dBuV/m

9 dBi Omni Antenna								
a mode	Frequency MHz	Uncorrected Peak (dBuV)	Cable Loss	ACF	DCF	Corrected	Limit (dBuV/m)	Margin
	5745	40.35	7.51	35	9.54	73.32	78.26	-4.94
	5805	39.44	7.83	35	9.54	72.73	78.26	-5.53
HT 20	Frequency MHz	Uncorrected Peak (dBuV)	Cable Loss	ACF	DCF	Corrected	Limit (dBuV/m)	Margin
	5745	44.38	7.51	35	9.54	77.35	78.26	-0.91
	5805	32.56	7.83	35	9.54	65.85	78.26	-12.41
HT 40	Frequency MHz	Uncorrected Peak (dBuV)	Cable Loss	ACF	DCF	Corrected	Limit (dBuV/m)	Margin
	5755	40	7.51	35	9.54	72.97	78.26	-5.29
	5795	36.65	7.83	35	9.54	69.94	78.26	-8.32

Table 65. EIRP Calculation, 9 dBi Omni

Note: EIRP Limit -17dBm/MHz = 78.26 dBuV/m

16 dBi Omni Antenna								
a mode	Frequency MHz	Uncorrected Peak (dBuV)	Cable Loss	ACF	DCF	Corrected	Limit (dBuV/m)	Margin
	5745	40.99	7.51	35	9.54	73.96	78.26	-4.3
	5805	32.7	7.83	35	9.54	65.99	78.26	-12.27
HT 20	Frequency MHz	Uncorrected Peak (dBuV)	Cable Loss	ACF	DCF	Corrected	Limit (dBuV/m)	Margin
	5745	41.59	7.51	35	9.54	74.56	78.26	-3.7
	5805	42.73	7.83	35	9.54	76.02	78.26	-2.24
HT 40	Frequency MHz	Uncorrected Peak (dBuV)	Cable Loss	ACF	DCF	Corrected	Limit (dBuV/m)	Margin
	5755	43.25	7.51	35	9.54	76.22	78.26	-2.04
	5795	42.44	7.83	35	9.54	75.73	78.26	-2.53

Table 66. EIRP Calculation, 16 dBi Sector

Note: EIRP Limit -17dBm/MHz = 78.26 dBuV/m

19dBi Panel Antenna								
a mode	Frequency MHz	Uncorrected Peak (dBuV)	Cable Loss	ACF	DCF	Corrected	Limit (dBuV/m)	Margin
	5745	34.42	7.51	35	9.54	67.39	78.26	-10.87
	5805	32.19	7.83	35	9.54	65.48	78.26	-12.78
HT 20	Frequency MHz	Uncorrected Peak (dBuV)	Cable Loss	ACF	DCF	Corrected	Limit (dBuV/m)	Margin
	5745	42.28	7.51	35	9.54	75.25	78.26	-3.01
	5805	41.37	7.83	35	9.54	74.66	78.26	-3.6
HT 40	Frequency MHz	Uncorrected Peak (dBuV)	Cable Loss	ACF	DCF	Corrected	Limit (dBuV/m)	Margin
	5755	43.8	7.51	35	9.54	76.77	78.26	-1.49
	5795	44.13	7.83	35	9.54	77.42	78.26	-0.84

Table 67. EIRP Calculation, 19 dBi Panel

Note: EIRP Limit -17dBm/MHz = 78.26 dBuV/m

EIRP, Port 1, 802.11a

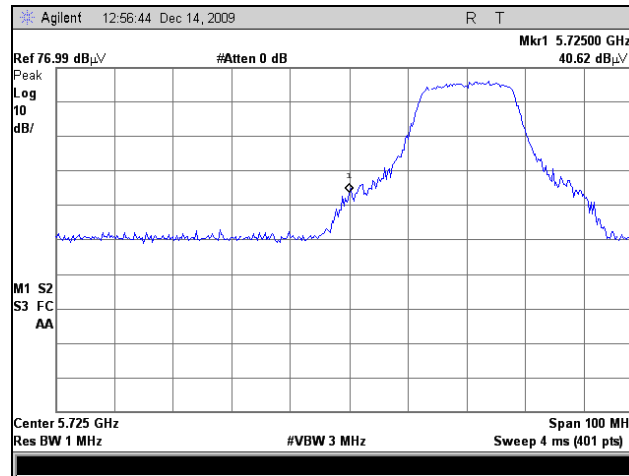

Plot 149. EIRP, 802.11a, Low Channel, 5745 MHz, 5 dBi Omni

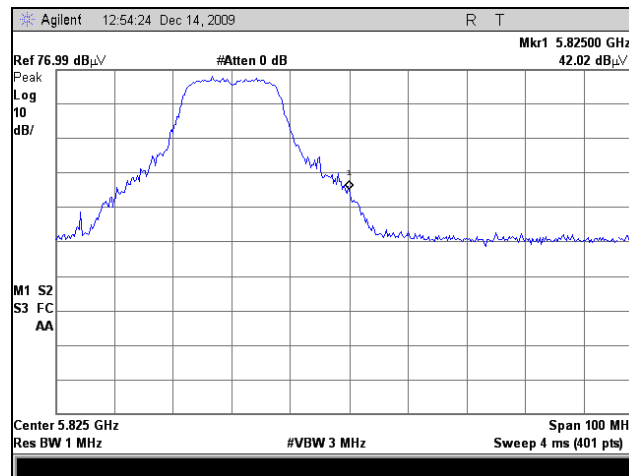

Plot 150. EIRP, 802.11a, High Channel, 5805 MHz, 5 dBi Omni

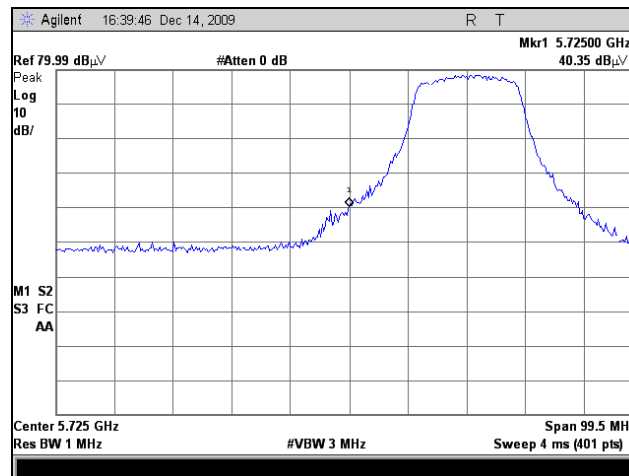

Plot 151. EIRP, 802.11a, Low Channel 5745 MHz, 9 dBi Omni

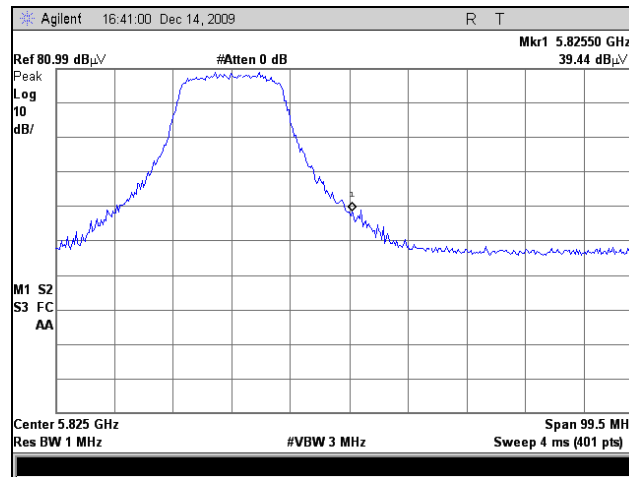

Plot 152. EIRP, 802.11a, High Channel 5805 MHz, 9 dBi Omni

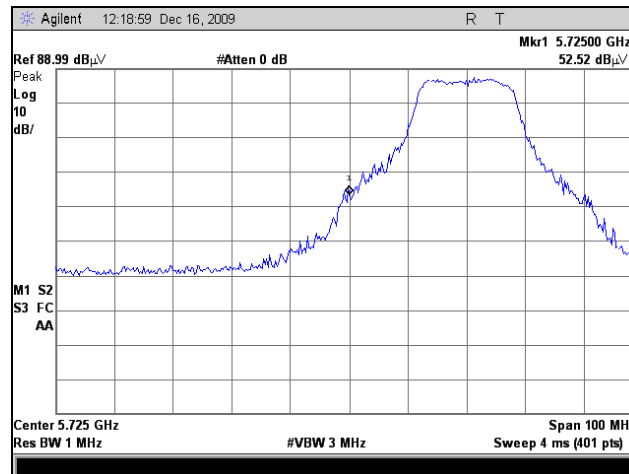

Plot 153. EIRP, 802.11a, Low Channel, 5745 MHz, 16 dBi Sector

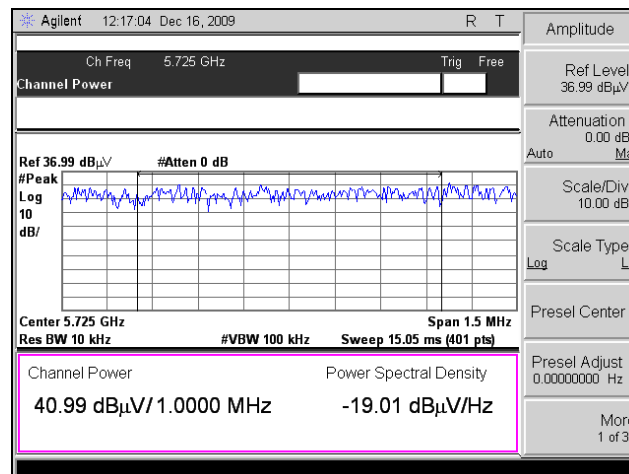

Plot 154. EIRP, 802.11a, Low Channel, 5745 MHz Over 1 MHz, 16 dBi Sector

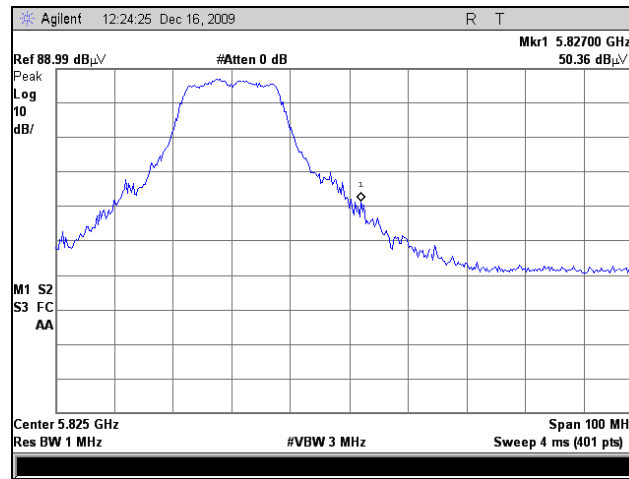

Plot 155. EIRP, 802.11a, High Channel 5805 MHz, 16 dBi Sector

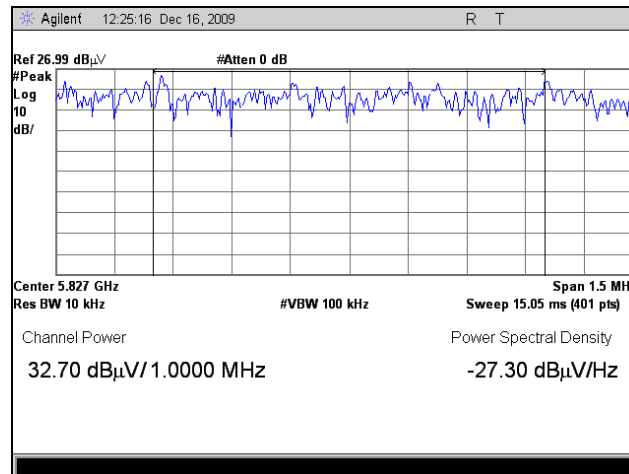

Plot 156. EIRP, 802.11a, High Channel, 5805 MHz Over 1 MHz, 16 dBi Sector

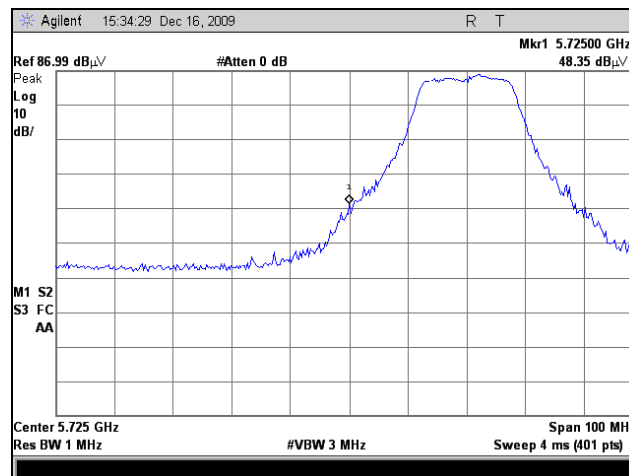

Plot 157. EIRP, 802.11a, Low Channel, 5745 MHz, 19 dBi Panel

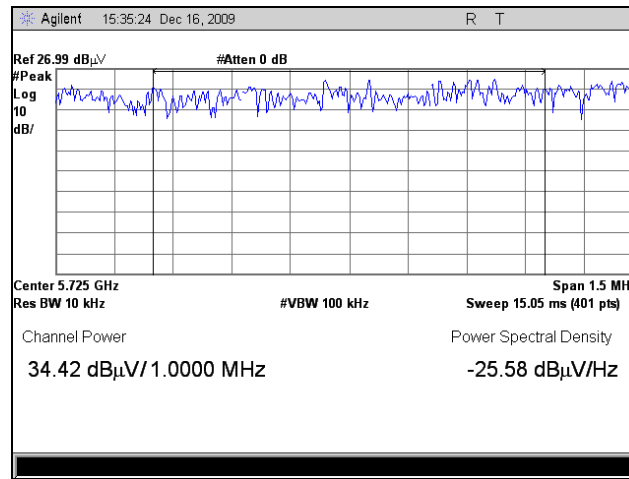

Plot 158. EIRP, 802.11a, Low Channel, 5745 MHz Over 1 MHz, 19 dBi Panel

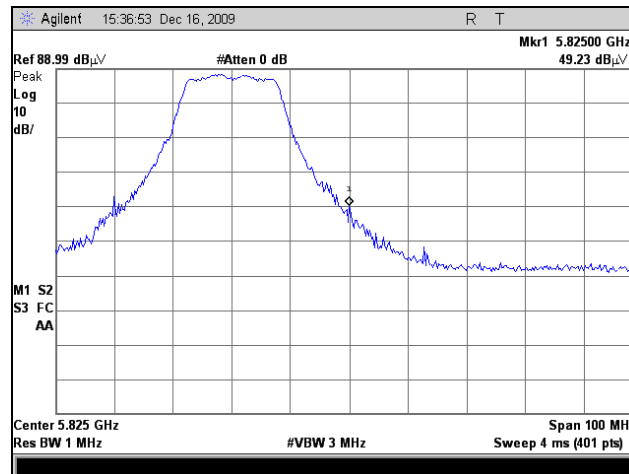

Plot 159. EIRP, 802.11a, High Channel, 5805 MHz, 19 dBi Panel

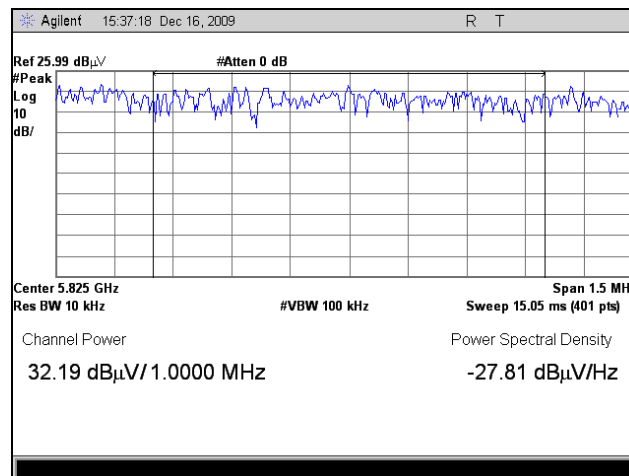

Plot 160. EIRP, 802.11a, High Channel, 5805 MHz Over 1 MHz, 19 dBi Panel

EIRP, 802.11n 20MHz

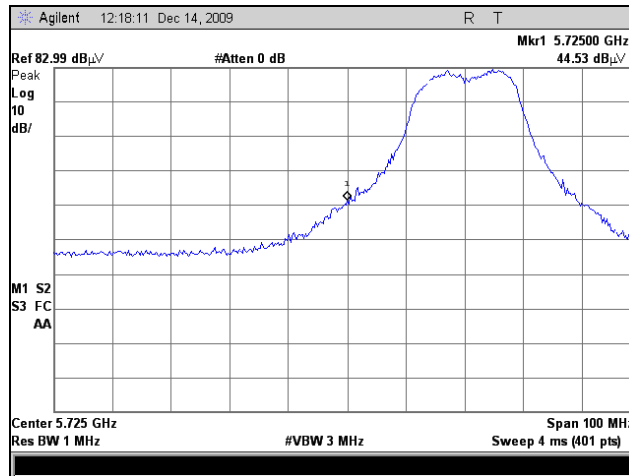

Plot 161. EIRP, 802.11n 20MHz, Low Channel, 5725 MHz, 5 dBi Omni

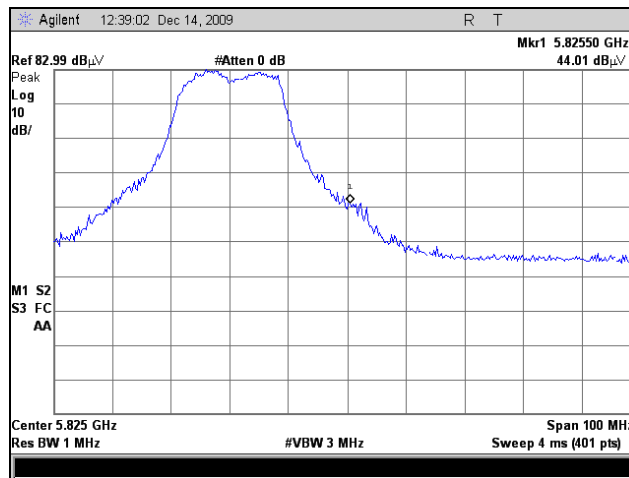

Plot 162. EIRP, 802.11n 20MHz, High Channel, 5080 MHz Over 1 MHz, 5 dBi Omni

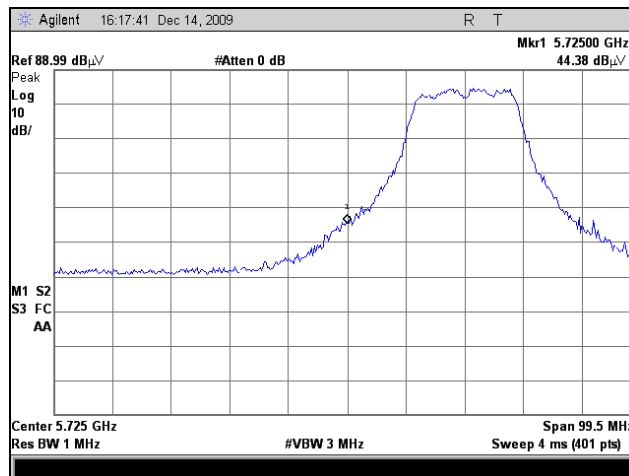

Plot 163. EIRP, 802.11n 20MHz, Low Channel, 5745 MHz, 9 dBi Omni

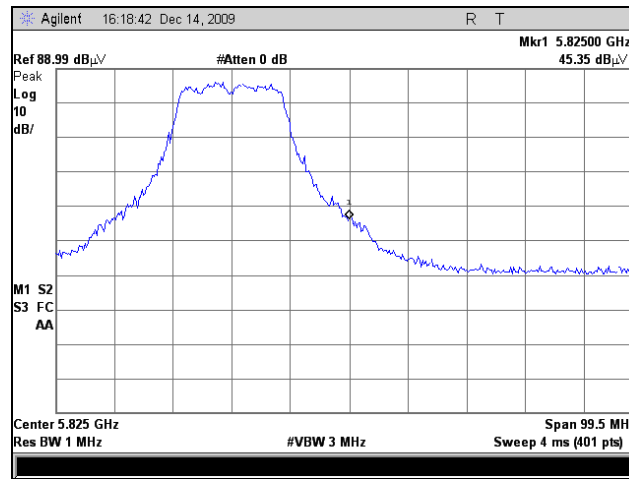

Plot 164. EIRP, 802.11n 20MHz, High Channel, 5805 MHz, 9 dBi Omni

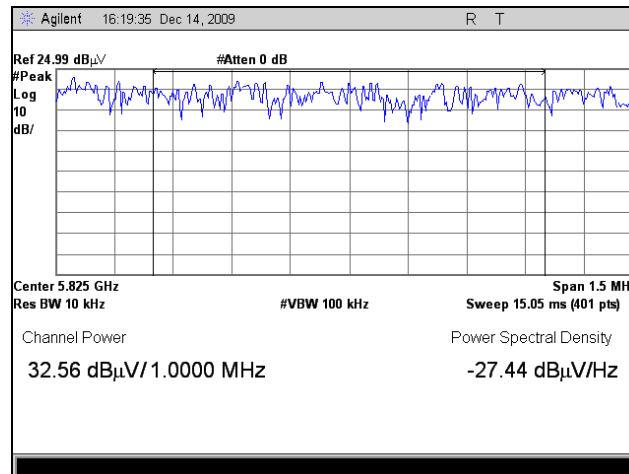

Plot 165. EIRP, 802.11n 20MHz, High Channel, 5805 MHz Over 1 MHz, 9 dBi Omni

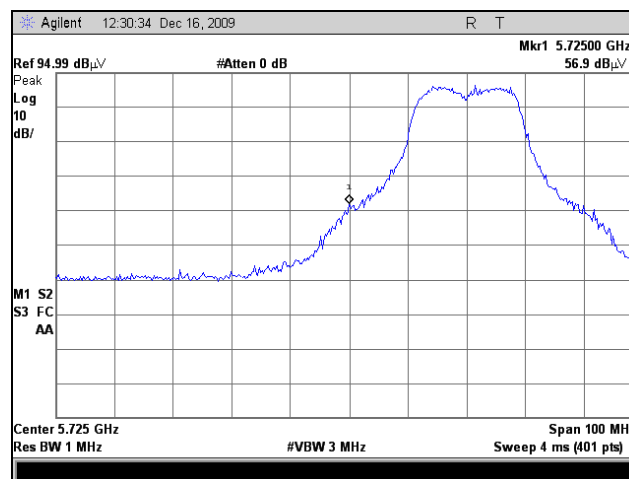

Plot 166. EIRP, 802.11n 20MHz, Low Channel, 5745 MHz, 16 dBi Sector

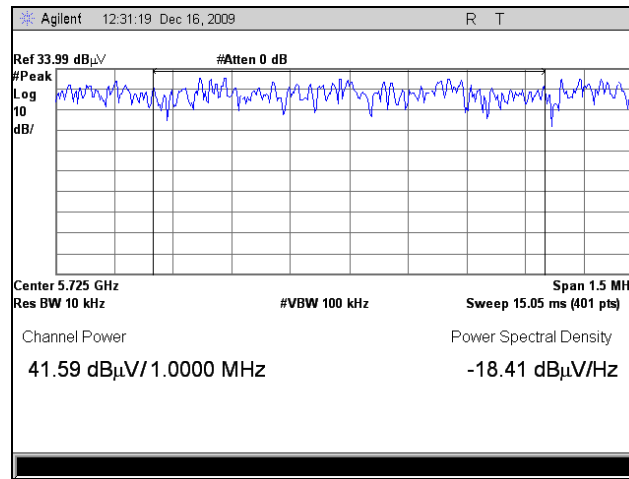

Plot 167. EIRP, 802.11n 20MHz, Low Channel, 5745 MHz Over 1 MHz, 16 dBi Sector

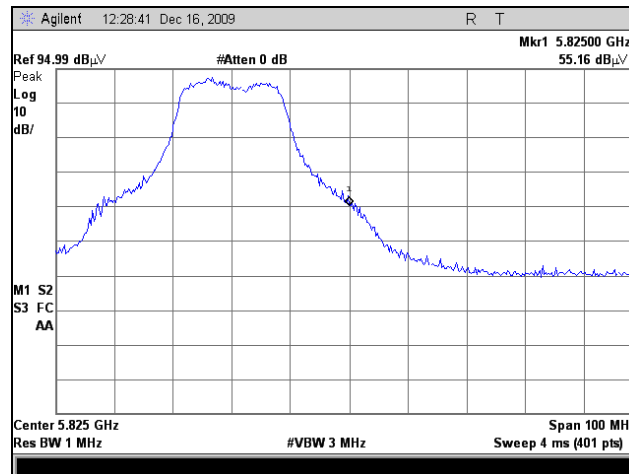

Plot 168. EIRP, 802.11n 20MHz, High Channel, 5805 MHz, 16 dBi Sector

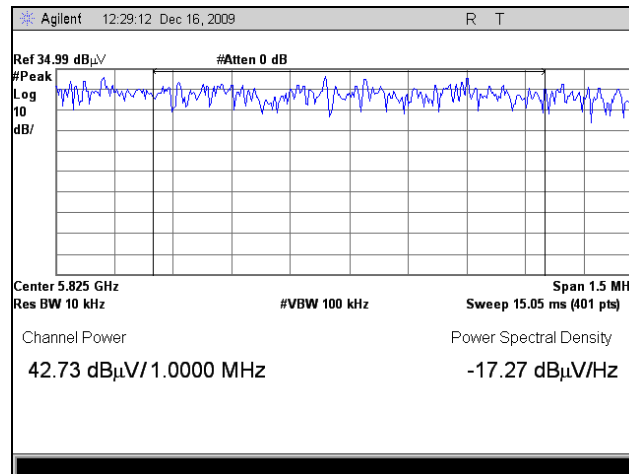

Plot 169. EIRP, 802.11n 20MHz, High Channel, 5805 MHz Over 1 MHz, 16 dBi Sector

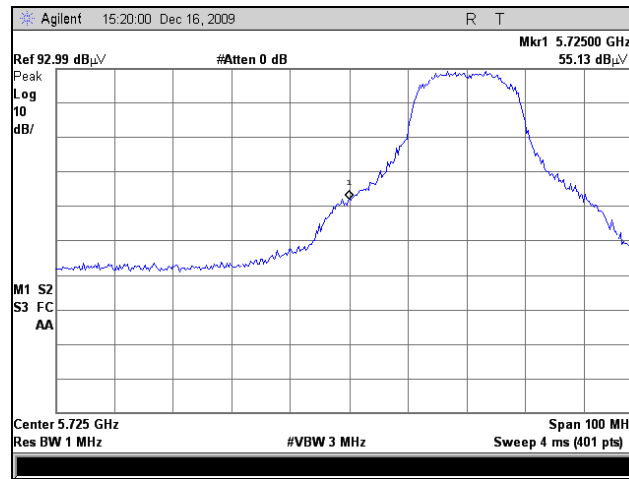

Plot 170. EIRP, 802.11n 20MHz, Low Channel, 5745 MHz, 19 dBi Panel

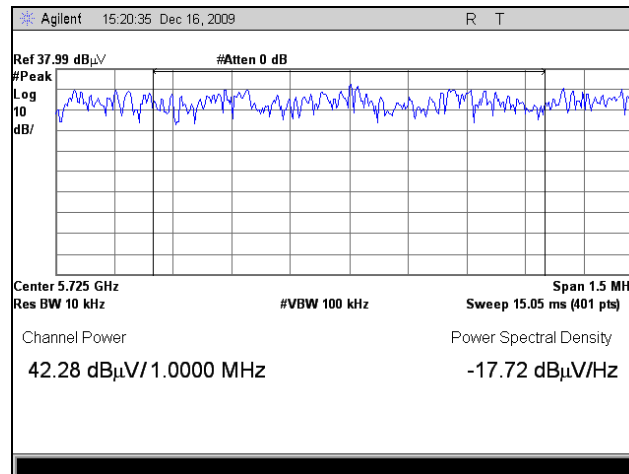

Plot 171. EIRP, 802.11n 20MHz, Low Channel, 5745 MHz Over 1 MHz, 19 dBi Panel

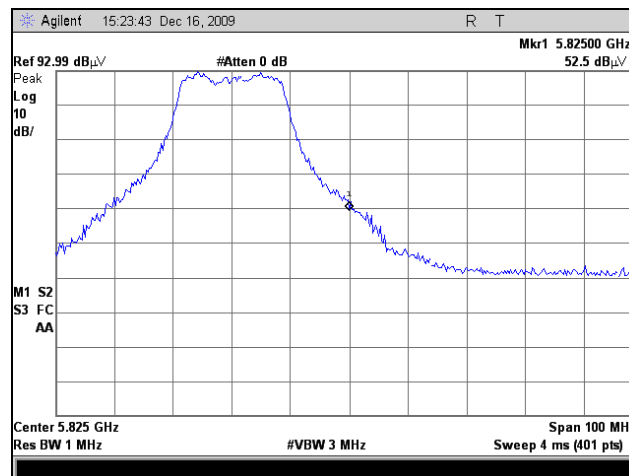

Plot 172. EIRP, 802.11n 20MHz, High Channel, 5805 MHz, 19 dBi Panel

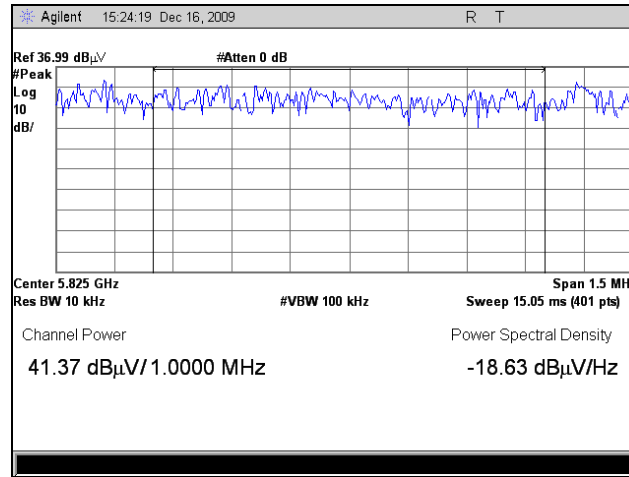

Plot 173. EIRP, 802.11n 20MHz, High Channel, 5805MHz Over 1 MHz, 19 dBi Panel

EIRP, 802.11n 40MHz

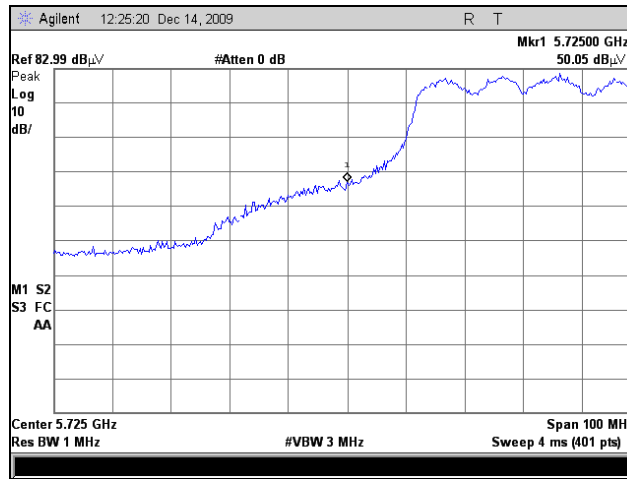

Plot 174. EIRP, 802.11n 40MHz, Low Channel, 5755 MHz, 5 dBi Omni

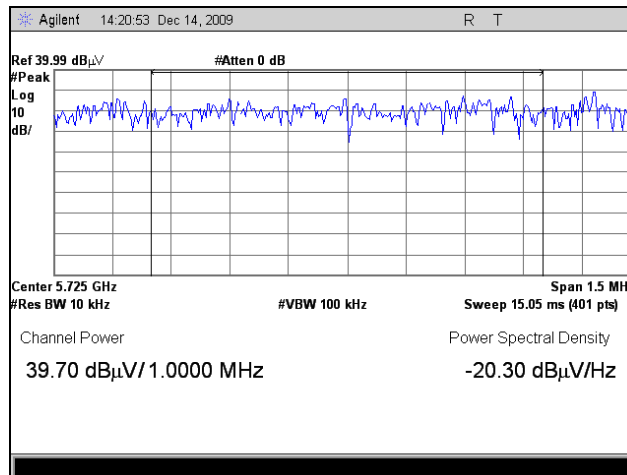

Plot 175. EIRP, 802.11n 40MHz, Low Channel, 5755 MHz Over 1 MHz, 5 dBi Omni

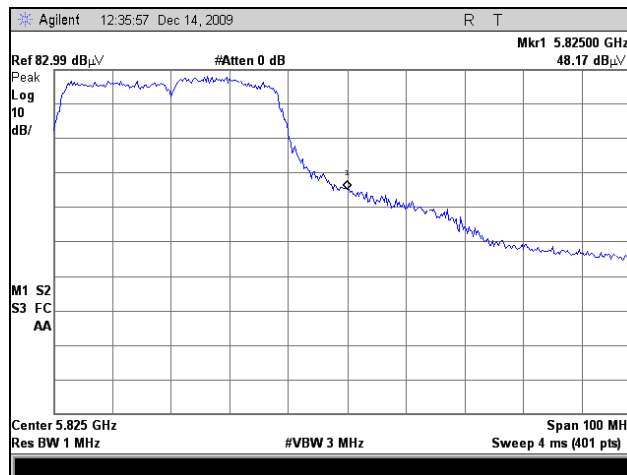

Plot 176. EIRP, 802.11n 40MHz, High Channel, 5795 MHz, 5 dBi Omni

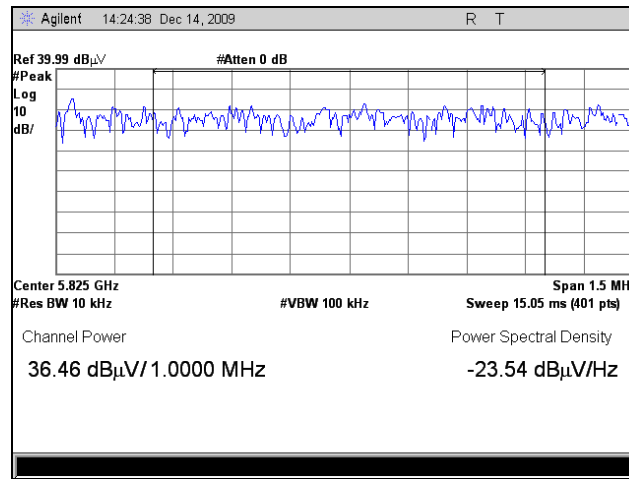

Plot 177. EIRP, 802.11n 40MHz, High Channel, 5895 MHz Over 1 MHz, 5 dBi Omni



Plot 178. EIRP, 802.11n 40MHz, Low Channel, 5755 MHz, 9 dBi Omni

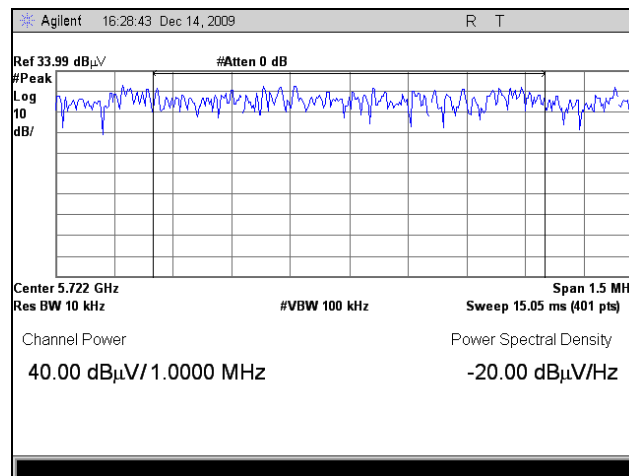

Plot 179. EIRP, 802.11n 40MHz, Low Channel, 5755 MHz Over 1 MHz, 9 dBi Omni

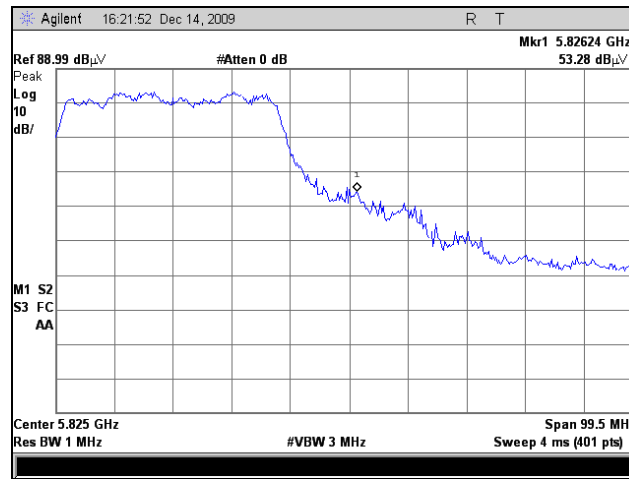

Plot 180. EIRP, 802.11n 40MHz, High Channel, 5795 MHz, 9 dBi Omni

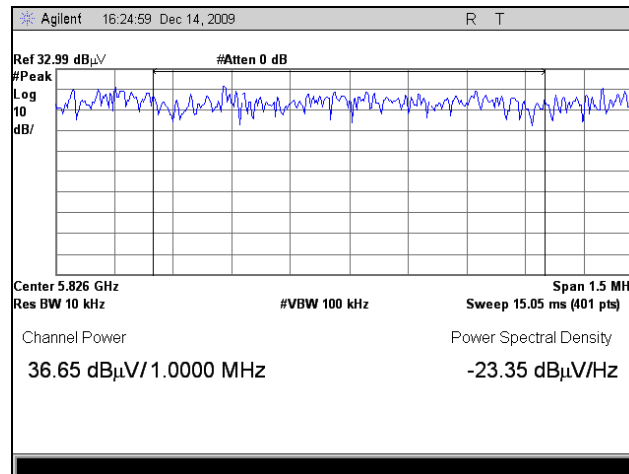

Plot 181. EIRP, 802.11n 40MHz, High Channel, 5795 MHz Over 1 MHz, 9 dBi Omni

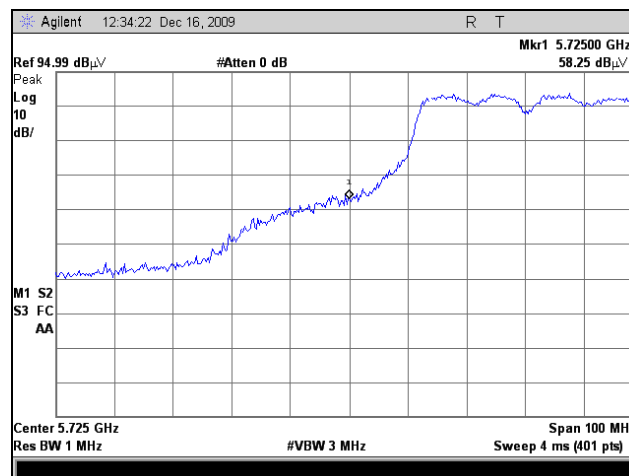

Plot 182. EIRP, 802.11n 40MHz, Low Channel, 5755 MHz, 16 dBi Sector

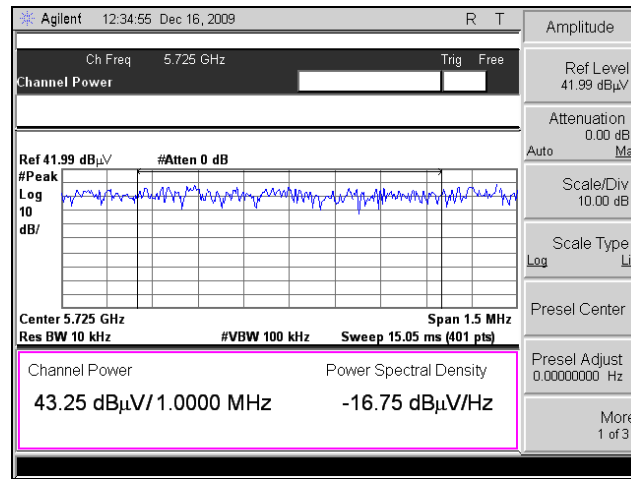

Plot 183. EIRP, 802.11n 40MHz, Low Channel, 5755 MHz Over 1 MHz, 16 dBi Sector

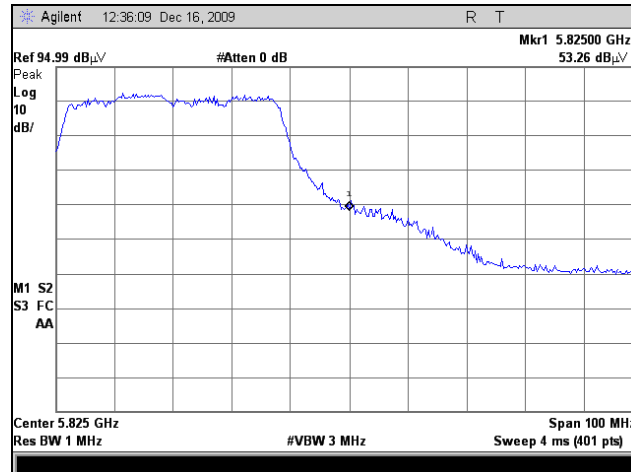

Plot 184. EIRP, 802.11n 40MHz, High Channel, 5795 MHz, 16 dBi Sector

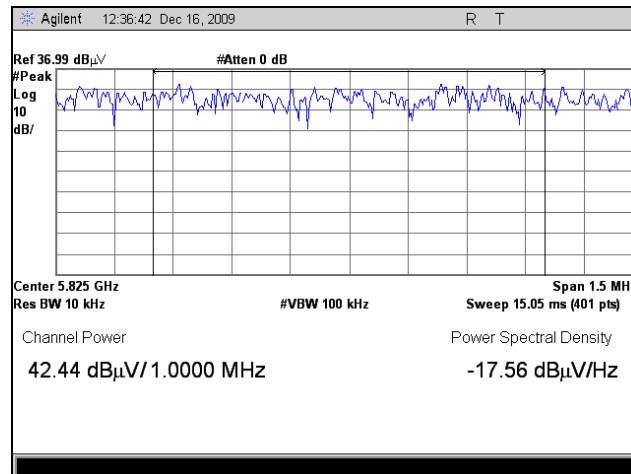

Plot 185. EIRP, 802.11n 40MHz, High Channel, 5795 MHz Over 1 MHz, 16 dBi Sector

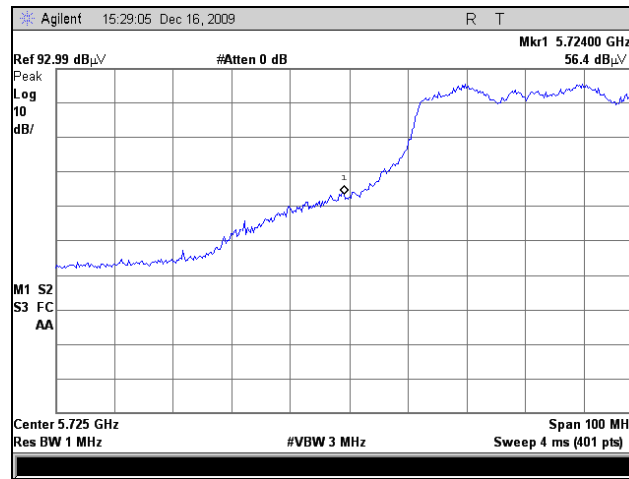

Plot 186. EIRP, 802.11n 40MHz, Low Channel, 5755 MHz, 19 dBi Panel

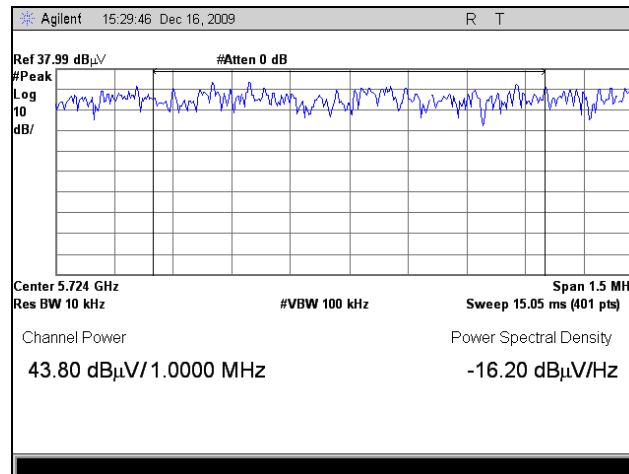

Plot 187. EIRP, 802.11n 40MHz, Low Channel, 5755 MHz Over 1 MHz, 19 dBi Panel

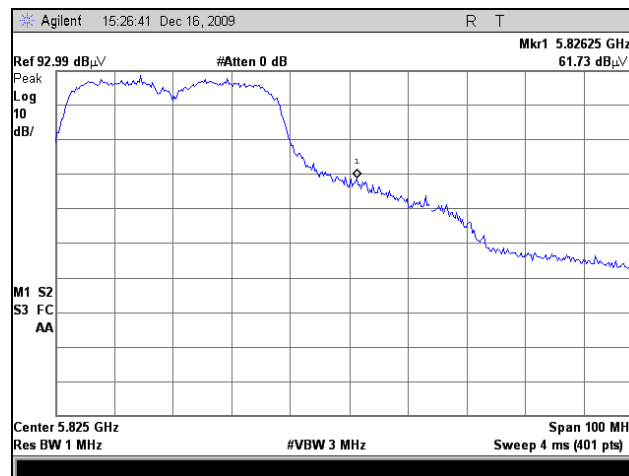

Plot 188. EIRP, 802.11n 40MHz, High Channel, 5795 MHz, 19 dBi Panel

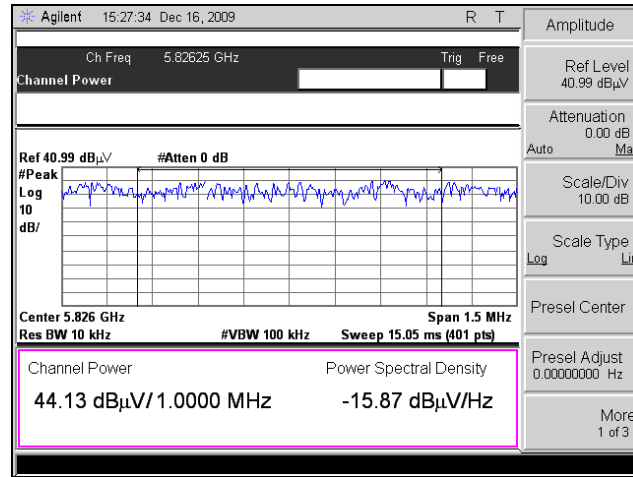

Plot 189. EIRP, 802.11n 40MHz, High Channel, 5795 MHz Over 1 MHz, 19 dBi Panel



Photograph 6. Test Equipment and Setup for Various Radiated Measurements, 9 dBi Omni

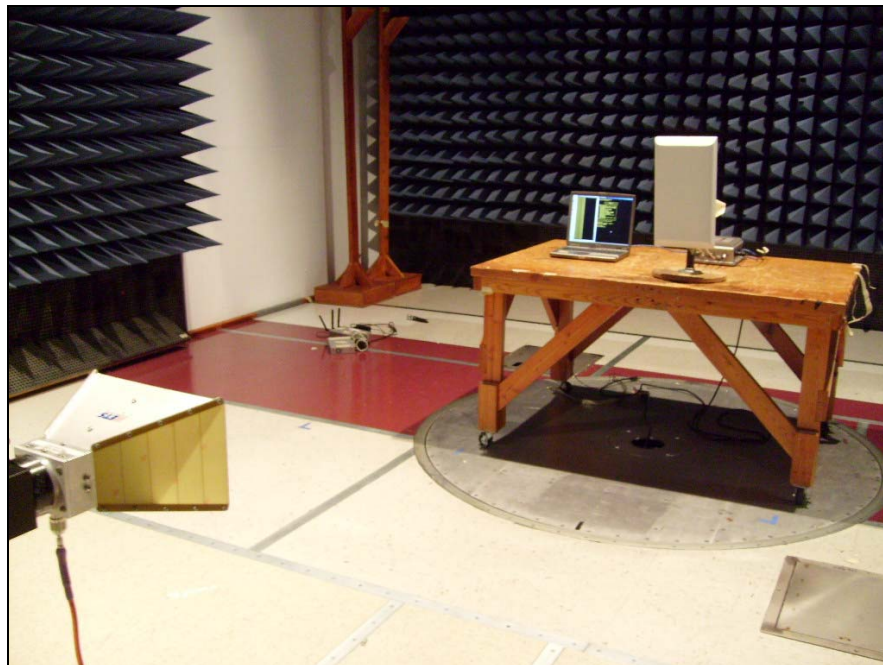

Photograph 7. Test Equipment and Setup for Various Radiated Measurements, 16 dBi Sector

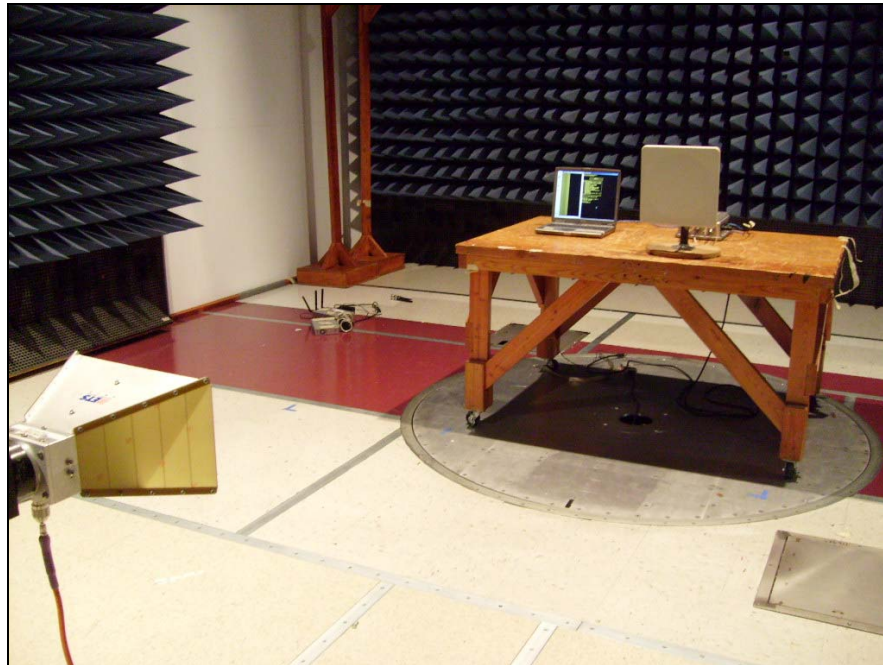

Photograph 8. Test Equipment and Setup for Various Radiated Measurements, 19 dBi Panel

Electromagnetic Compatibility Criteria for Intentional Radiators

§ 15.407(f) RF Exposure

RF Exposure Requirements: §1.1307(b)(1) and §1.1307(b)(2): Systems operating under the provisions of this section shall be operated in a manner that ensures that the public is not exposed to radio frequency energy levels in excess of the Commission's guidelines.

RF Radiation Exposure Limit: §1.1310: As specified in this section, the Maximum Permissible Exposure (MPE) Limit shall be used to evaluate the environmental impact of human exposure to radiofrequency (RF) radiation as specified in Sec. 1.1307(b), except in the case of portable devices which shall be evaluated according to the provisions of Sec. 2.1093 of this chapter.

MPE Limit Calculation: EUT's operating frequencies @ 5745-5805MHz; highest conducted power = 22.78dBm (peak) therefore, **Limit for Uncontrolled exposure: 1 mW/cm² or 10 W/m²**

EUT maximum antenna gain = **9dBi Omni.**

Equation from page 18 of OET 65, Edition 97-01

$$S = PG / 4\pi R^2 \quad \text{or} \quad R = \sqrt{PG / 4\pi S}$$

where, S = Power Density (1 mW/cm²)
P = Power Input to antenna (189.6mW)
G = Antenna Gain (7.94 numeric)

$$S = (189.67 * 7.94 / 4 * 3.14 * 20.0^2) = (1506.607 / 5024) = \mathbf{2.99 \text{ mW/cm}^2 @ 20\text{cm separation}}$$

EUT maximum antenna gain = **16dBi Sector.**

Equation from page 18 of OET 65, Edition 97-01

$$S = PG / 4\pi R^2 \quad \text{or} \quad R = \sqrt{PG / 4\pi S}$$

where, S = Power Density (1 mW/cm²)
P = Power Input to antenna (189.6mW)
G = Antenna Gain (39.81 numeric)

$$R = (189.6 * 39.81 / 4 * 3.14 * 1.0)^{1/2} = (7550.922 / 12.56)^{1/2} = \mathbf{24.51\text{cm}}$$

EUT maximum antenna gain = **19dBi Panel.**

Equation from page 18 of OET 65, Edition 97-01

$$S = PG / 4\pi R^2 \quad \text{or} \quad R = \sqrt{PG / 4\pi S}$$

where, S = Power Density (1 mW/cm²)
P = Power Input to antenna (189.6mW)
G = Antenna Gain (79.432 numeric)

$$R = (189.6 * 79.432 / 4 * 3.14 * 1.0)^{1/2} = (15066.07 / 12.56)^{1/2} = \mathbf{34.63\text{cm}}$$

Electromagnetic Compatibility Criteria for Intentional Radiators

§ 15.407(g) Frequency Stability

- Test Requirements:** § 15.407(g): Manufacturers of U-NII devices are responsible for ensuring frequency stability such that an emission is maintained within the band of operation under all conditions of normal operation as specified in the users manual.
- Test Procedure:** The EUT was placed in an environmental chamber and the RF port was connected directly to a spectrum analyzer through an attenuator. Depending on which band was being investigated, the EUT was set to transmit at the low, mid, and high with the appropriate power level. If the EUT was capable of transmitting a CW carrier then the spectrum analyzer's frequency counting function was used to measure the actual frequency. If only a modulated carrier was available then the frequency relative to -10dBc above and below the carrier was measured and the carrier frequency was determined using $(f1+f2)/2$. The frequency of the carrier was measured at normal and extreme conditions with the temperature range of -40°C to +60°C .
- Test Results:** The EUT was found compliant with the requirements of §15.407(g)
- Test Engineer(s):** 12/17/09
- Test Date(s):** Anderson Soungpanya

Frequency Stability, 802.11a

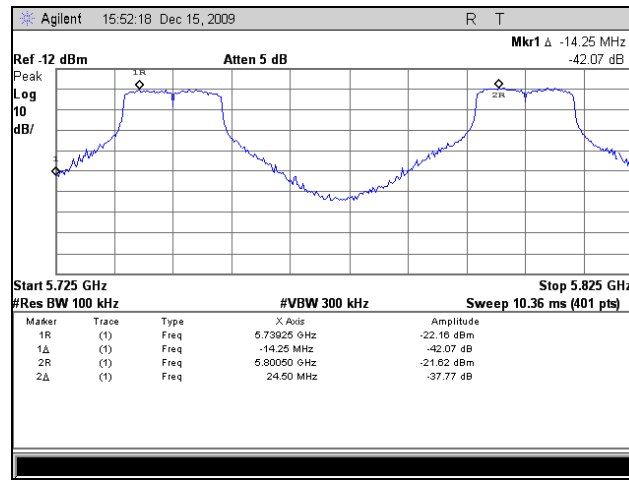

Plot 190. Frequency Stability, 802.11a 20MHz Bandwidth, -40C, 108 VAC

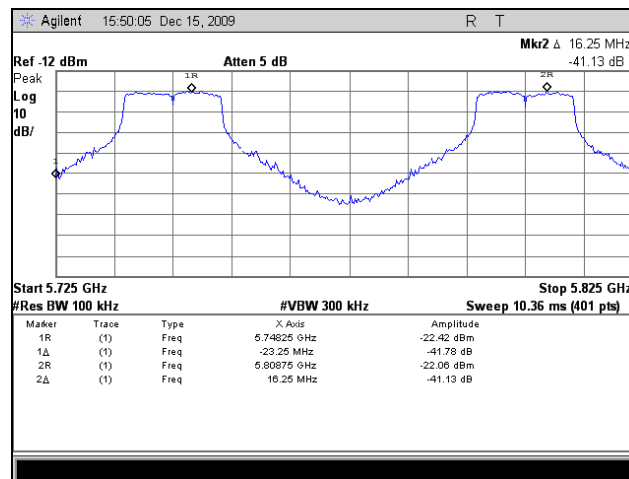

Plot 191. Frequency Stability, 802.11a 20MHz Bandwidth, -40C, 120 VAC

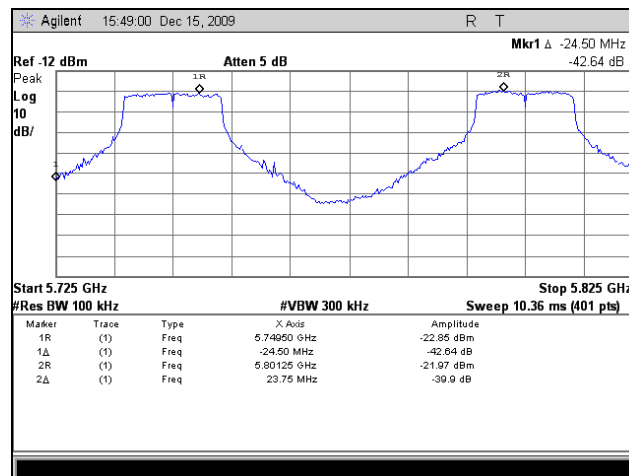

Plot 192. Frequency Stability, 802.11a 20MHz Bandwidth, -40C, 132 VAC

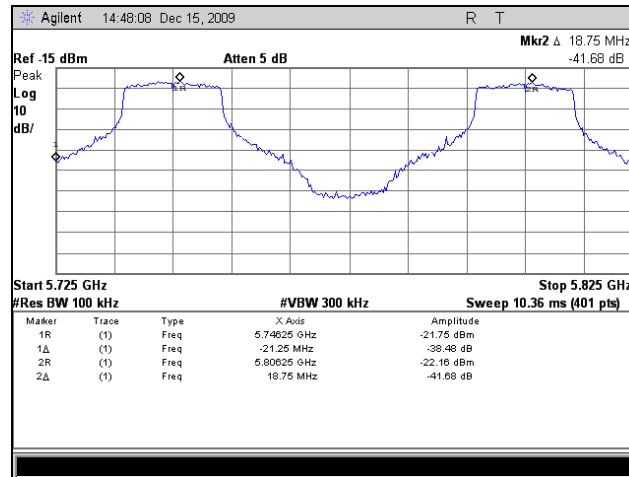

Plot 193. Frequency Stability, 802.11a 20MHz Bandwidth, 20C, 108 VAC

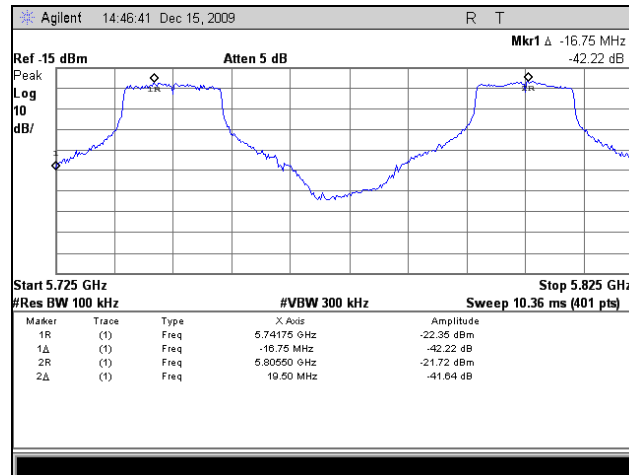

Plot 194. Frequency Stability, 802.11a 20MHz Bandwidth, 20C, 120 VAC

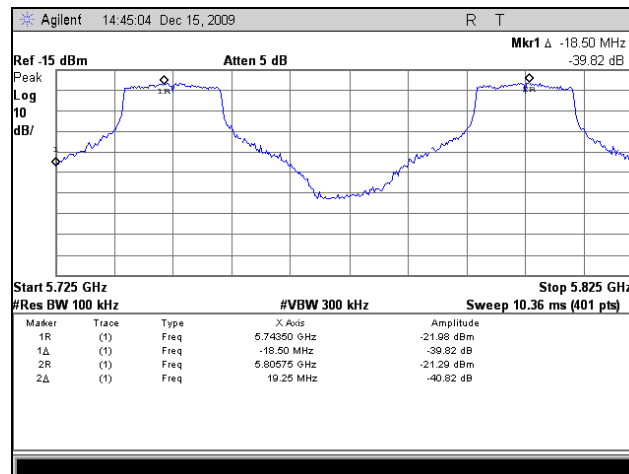

Plot 195. Frequency Stability, 802.11a 20MHz Bandwidth, 20C, 132 VAC

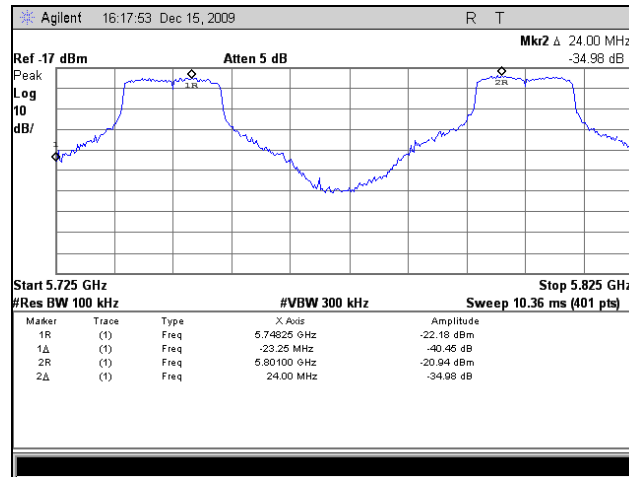

Plot 196. Frequency Stability, 802.11a 20MHz Bandwidth, 60C, 108 VAC

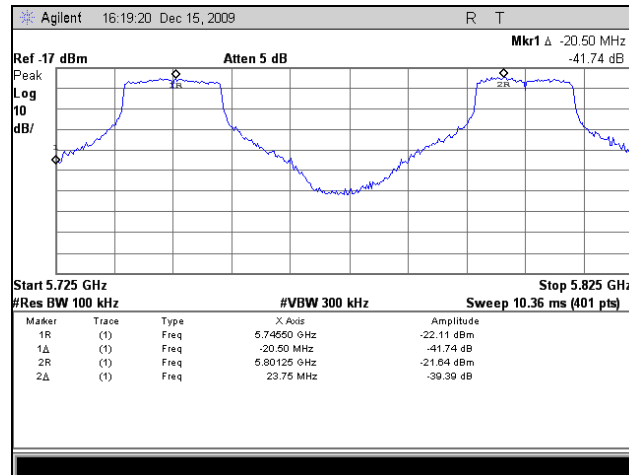

Plot 197. Frequency Stability, 802.11a 20MHz Bandwidth, 60C, 120 VAC

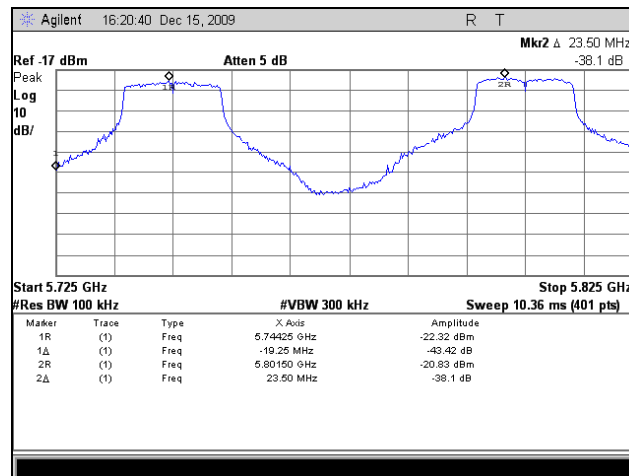

Plot 198. Frequency Stability, 802.11a 20MHz Bandwidth, 60C, 132 VAC

Frequency Stability, 802.11n 20 MHz

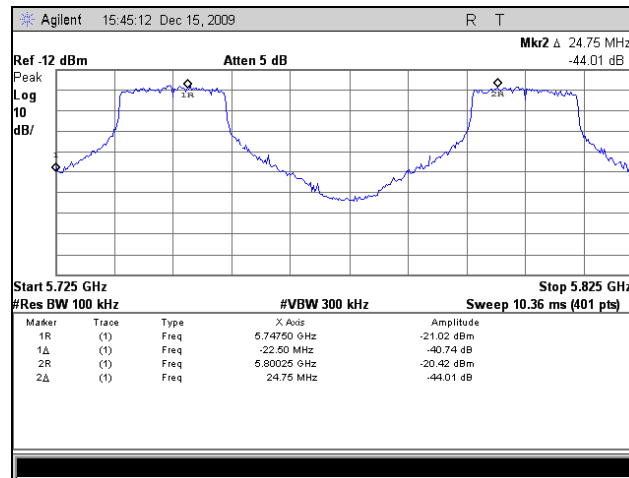

Plot 199. Frequency Stability, 802.11n 20MHz Bandwidth, -40C, 108 VAC

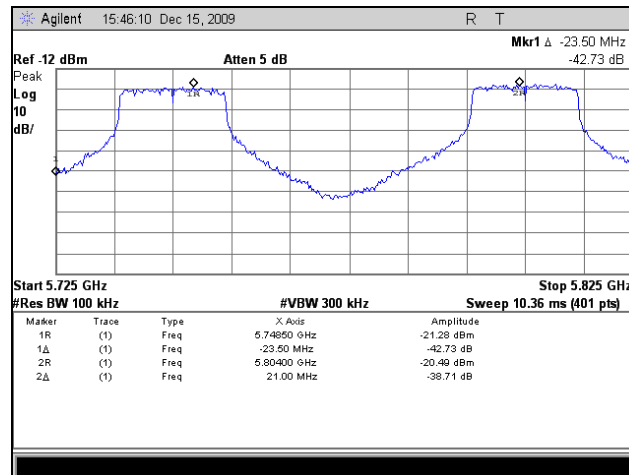

Plot 200. Frequency Stability, 802.11n 20MHz Bandwidth, -40C, 120 VAC

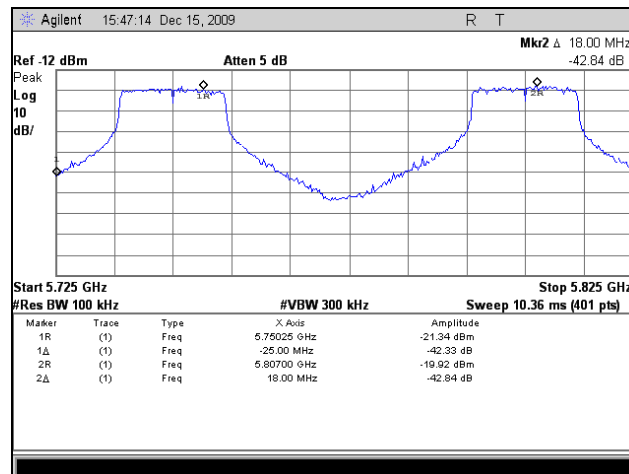

Plot 201. Frequency Stability, 802.11n 20MHz Bandwidth, -40C, 132 VAC

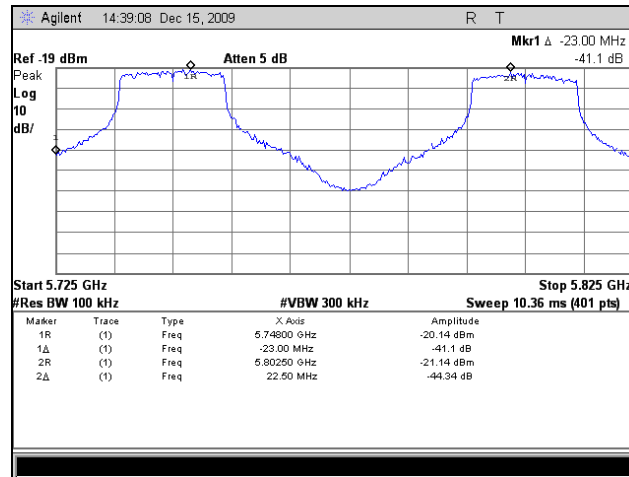

Plot 202. Frequency Stability, 802.11n 20MHz Bandwidth, 20C, 108 VAC

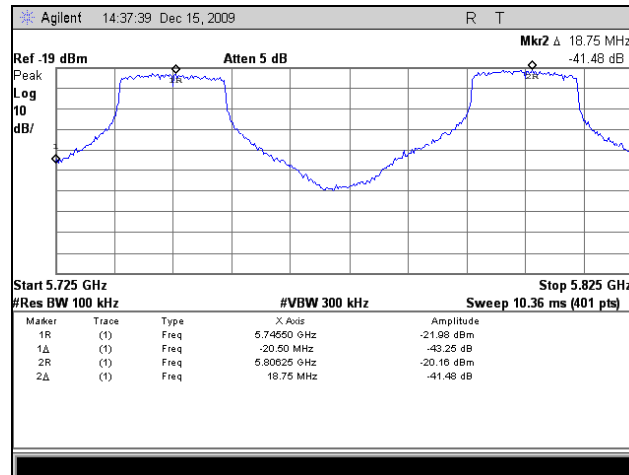

Plot 203. Frequency Stability, 802.11n 20MHz Bandwidth, 20C, 120 VAC

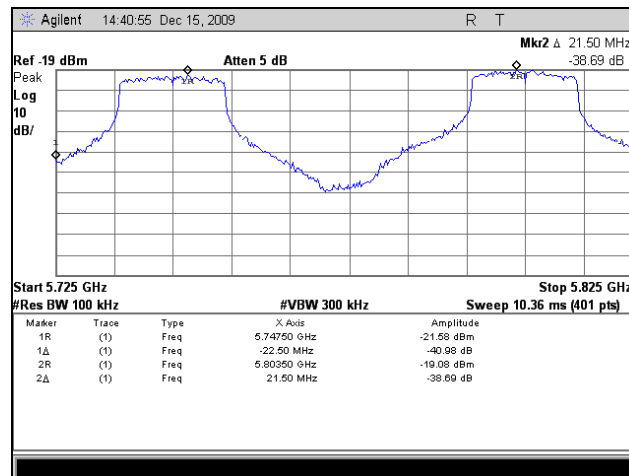

Plot 204. Frequency Stability, 802.11n 20MHz Bandwidth, 20C, 132 VAC

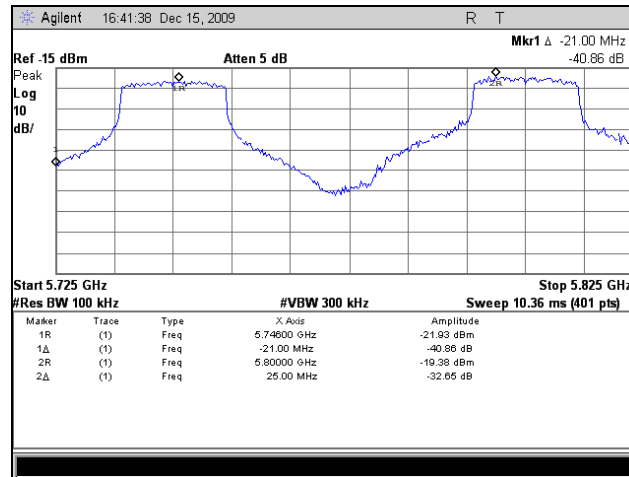

Plot 205. Frequency Stability, 802.11n 20MHz Bandwidth, 60C, 108 VAC

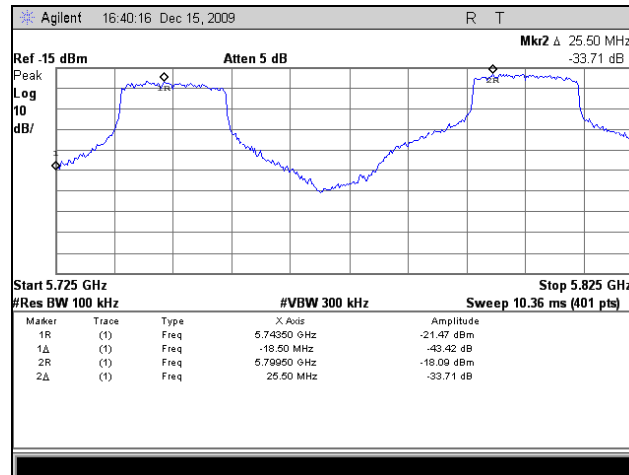

Plot 206. Frequency Stability, 802.11n 20MHz Bandwidth, 60C, 120 VAC

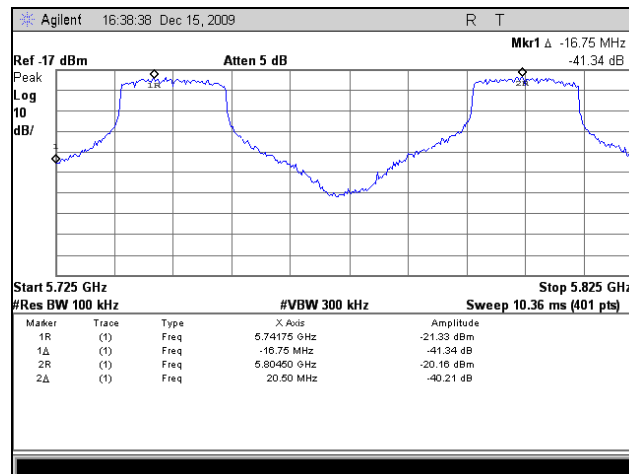

Plot 207. Frequency Stability, 802.11n 20MHz Bandwidth, 60C, 132 VAC

Frequency Stability, 802.11n 40MHz

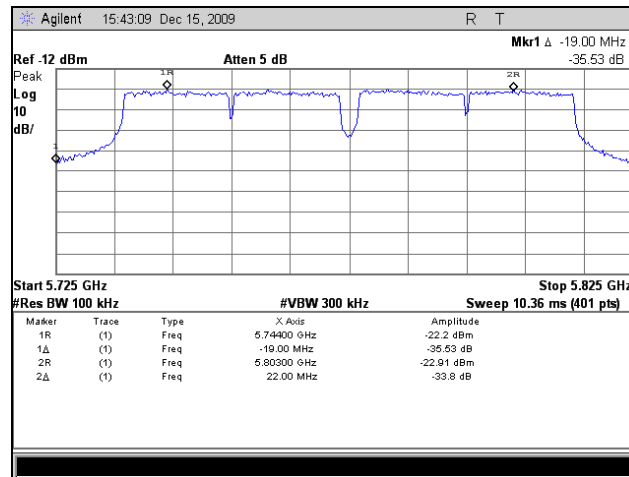

Plot 208. Frequency Stability, 802.11n 40MHz Bandwidth, -40C, 108 VAC

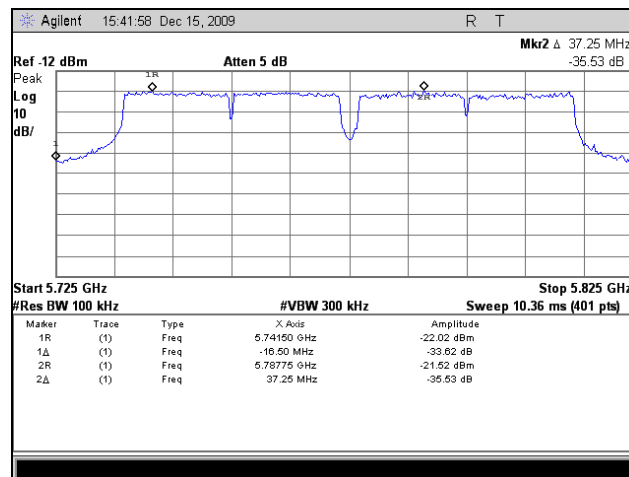

Plot 209. Frequency Stability, 802.11n 40MHz Bandwidth, -40C, 120 VAC

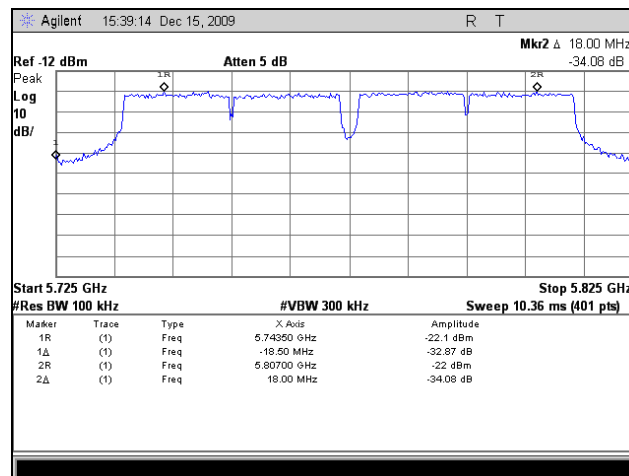

Plot 210. Frequency Stability, 802.11n 40MHz Bandwidth, -40C, 132 VAC

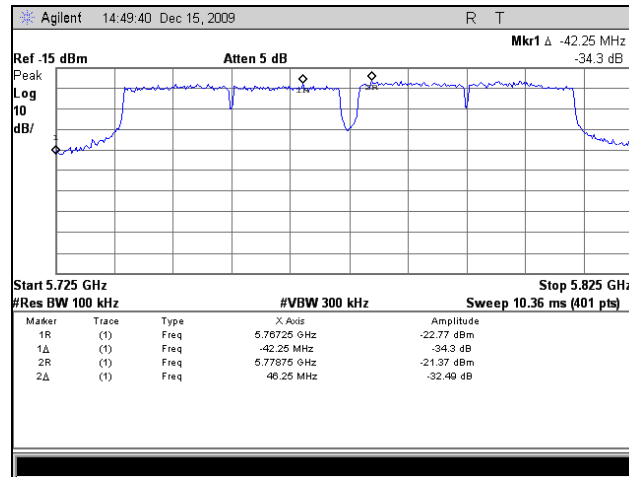

Plot 211. Frequency Stability, 802.11n 40MHz Bandwidth, 20C, 108 VAC

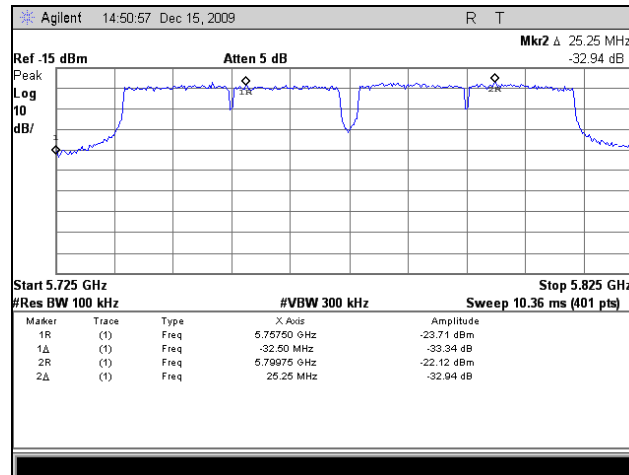

Plot 212. Frequency Stability, 802.11n 40MHz Bandwidth, 20C, 120 VAC

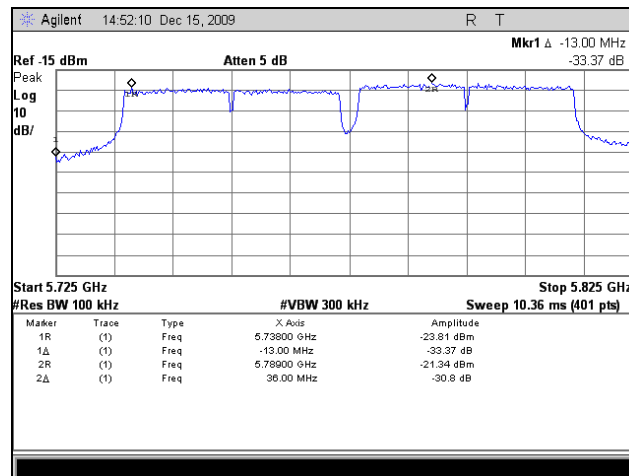

Plot 213. Frequency Stability, 802.11n 40MHz Bandwidth, 20C, 132 VAC

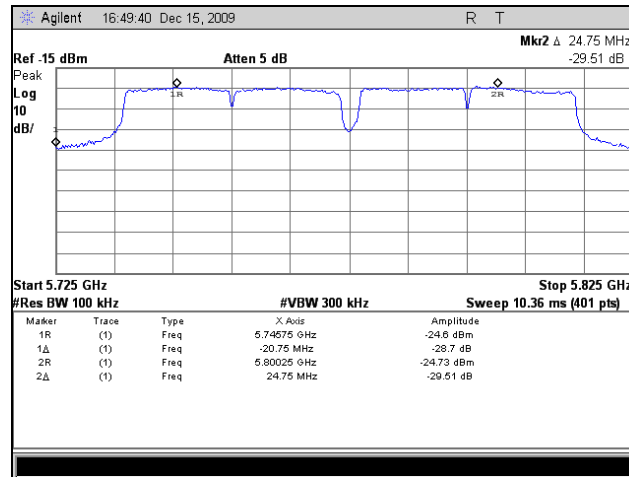

Plot 214. Frequency Stability, 802.11n 40MHz Bandwidth, 60C, 108 VAC

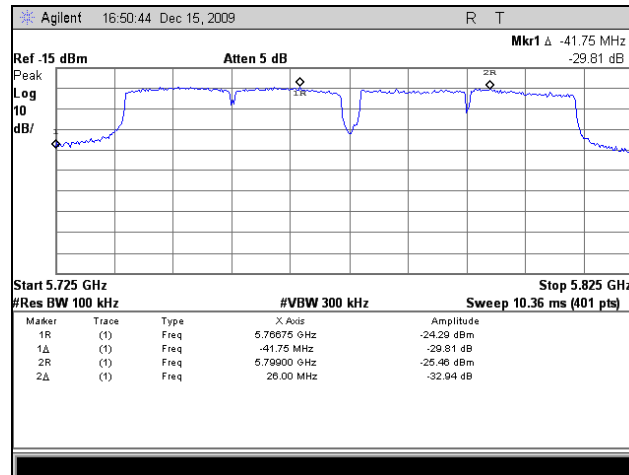

Plot 215. Frequency Stability, 802.11n 40MHz Bandwidth, 60C, 120 VAC

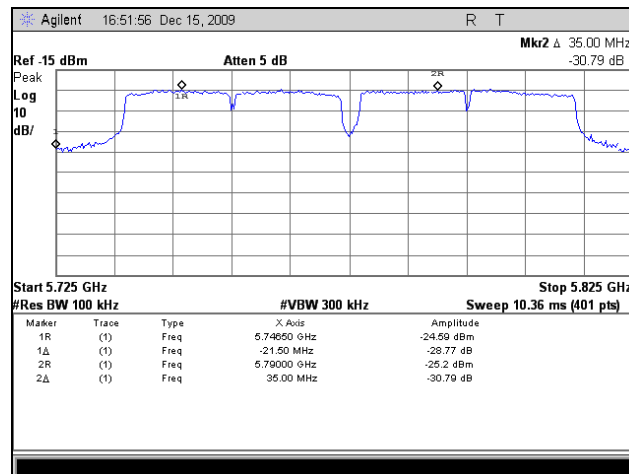

Plot 216. Frequency Stability, 802.11n 40MHz Bandwidth, 60C, 132 VAC

IV. Test Equipment

Test Equipment

Calibrated test equipment utilized during testing was maintained in a current state of calibration per the requirements of ANSI/NCSL Z540-1-1994 and ANSI/ISO/IEC 17025:2000.

MET Asset #	Equipment	Manufacturer	Model	Last Cal Date	Cal Due Date
1S2421	EMI RECEIVER	ROHDE&SCHWARZ	ESIB 7	05/27/2009	05/27/2010
1S2121	PRE-AMPLIFIER	HEWLETT PACKARD	8449B	SEE NOTE	
1S2198	HORN ANTENNA	EMCO	3115	09/03/2009	09/03/2010
1S2202	ANTENNA, HORN, 1 METER	EMCO	3116	04/10/2007	04/10/2010
N/A	HIGH PASS FILTER	MICRO-TRONICS	HPM13146	SEE NOTE	
1S2481	CHAMBER, 10 METER	ETS-LINDGREN	DKE 8X8 DBL	12/26/2008	12/26/2009
1S2041	COUPLER, BI DIRECTIONAL COAXIAL	NARDA	N/A	SEE NOTE	
1S2460	ANALYZER, SPECTRUM 9 KHZ-40GHZ	AGILENT	E4407B	04/14/2009	04/14/2010
1S2034	COUPLER, DIRECTIONAL 1-20 GHZ	KRYTAR	101020020	SEE NOTE	
1S2508	LISN	SOLAR ELECTRONICS	9252-50-R24-BNC	06/05/2009	06/05/2010
1S2512	TRANSIENT LIMITER	AGILENT	11947A	SEE NOTE	
1S2520	THERMO-HYGROMETER	FISHER SCIENTIFIC	11-661-7D	11/11/2009	11/11/2010
1S2482	CHAMBER, 5 METER	PANASHIELD	641431	10/16/2009	10/16/2010
1S2108	RECEIVER, EMI, RF FILTER SECTION	HP	85460A	11/10/2009	11/10/2010
1S2399	TURNTABLE CONTROLLER	SUNOL SCIENCE	SC99V	SEE NOTE	
1S2485	BILOG ANTENNA	TESEQ	CBL6112D	03/20/2009	03/20/2010
N/A	2-6GHZ COMBINER	MINI CIRCUITS	ZN4PD-1-63-S+	SEE NOTE	
1S2109	RF FILTER SECTION	HEWLETT PACKARD	85460A	11/10/2009	11/10/2010
1S2041	COUPLER, BI DIRECTIONAL COAXIAL	NARDA	N/A	SEE NOTE	
1S2128	HARMONIC MIXER	HEWLETT PACKARD	11970A	11/22/2008	11/22/2010
1S2129	HARMONIC MIXER	HEWLETT PACKARD	11970K	11/22/2008	11/22/2010

Table 68. Test Equipment List

Note: Functionally tested equipment is verified using calibrated instrumentation at the time of testing.

V. Certification & User's Manual Information

Certification & User's Manual Information

A. Certification Information

The following is extracted from Title 47 of the Code of Federal Regulations, Part 2, Subpart I — Marketing of Radio frequency devices:

§ 2.801 Radio-frequency device defined.

As used in this part, a radio-frequency device is any device which in its operation is capable of Emitting radio-frequency energy by radiation, conduction, or other means. Radio- frequency devices include, but are not limited to:

- (a) The various types of radio communication transmitting devices described throughout this chapter.
- (b) *The incidental, unintentional and intentional radiators defined in Part 15 of this chapter.*
- (c) The industrial, scientific, and medical equipment described in Part 18 of this chapter.
- (d) Any part or component thereof which in use emits radio-frequency energy by radiation, conduction, or other means.

§ 2.803 Marketing of radio frequency devices prior to equipment authorization.

- (a) Except as provided elsewhere in this chapter, no person shall sell or lease, or offer for sale or lease (including advertising for sale or lease), or import, ship or distribute for the purpose of selling or leasing or offering for sale or lease, any radio frequency device unless:
 - (1) In the case of a device subject to certification, such device has been authorized by the Commission in accordance with the rules in this chapter and is properly identified and labeled as required by §2.925 and other relevant sections in this chapter; or
 - (2) In the case of a device that is not required to have a grant of equipment authorization issued by the Commission, but which must comply with the specified technical standards prior to use, such device also complies with all applicable administrative (including verification of the equipment or authorization under a Declaration of Conformity, where required), technical, labeling and identification requirements specified in this chapter.
- (d) Notwithstanding the provisions of paragraph (a) of this section, the offer for sale solely to business, commercial, industrial, scientific or medical users (but not an offer for sale to other parties or to end users located in a residential environment) of a radio frequency device that is in the conceptual, developmental, design or pre-production stage is permitted prior to equipment authorization or, for devices not subject to the equipment authorization requirements, prior to a determination of compliance with the applicable technical requirements *provided* that the prospective buyer is advised in writing at the time of the offer for sale that the equipment is subject to the FCC rules and that the equipment will comply with the appropriate rules before delivery to the buyer or to centers of distribution.

- (e)(1) Notwithstanding the provisions of paragraph (a) of this section, prior to equipment authorization or determination of compliance with the applicable technical requirements any radio frequency device may be operated, but not marketed, for the following purposes and under the following conditions:
- (i) *Compliance testing*;
 - (ii) Demonstrations at a trade show provided the notice contained in paragraph (c) of this section is displayed in a conspicuous location on, or immediately adjacent to, the device;
 - (iii) Demonstrations at an exhibition conducted at a business, commercial, industrial, scientific or medical location, but excluding locations in a residential environment, provided the notice contained in paragraphs (c) or (d) of this section, as appropriate, is displayed in a conspicuous location on, or immediately adjacent to, the device;
 - (iv) Evaluation of product performance and determination of customer acceptability, provided such operation takes place at the manufacturer's facilities during developmental, design or pre-production states; or
 - (v) Evaluation of product performance and determination of customer acceptability where customer acceptability of a radio frequency device cannot be determined at the manufacturer's facilities because of size or unique capability of the device, provided the device is operated at a business, commercial, industrial, scientific or medical user's site, but not at a residential site, during the development, design or pre-production stages.
- (e)(2) For the purpose of paragraphs (e)(1)(iv) and (e)(1)(v) of this section, the term *manufacturer's facilities* includes the facilities of the party responsible for compliance with the regulations and the manufacturer's premises, as well as the facilities of other entities working under the authorization of the responsible party in connection with the development and manufacture, but not the marketing, of the equipment.
- (f) For radio frequency devices subject to verification and sold solely to business, commercial, industrial, scientific and medical users (excluding products sold to other parties or for operation in a residential environment), parties responsible for verification of the devices shall have the option of ensuring compliance with the applicable technical specifications of this chapter at each end user's location after installation, provided that the purchase or lease agreement includes a proviso that such a determination of compliance be made and is the responsibility of the party responsible for verification of the equipment.

Certification & User's Manual Information

The following is extracted from Title 47 of the Code of Federal Regulations, Part 2, Subpart J — Equipment Authorization Procedures:

§ 2.901 Basis and Purpose

- (a) In order to carry out its responsibilities under the Communications Act and the various treaties and international regulations, and in order to promote efficient use of the radio spectrum, the Commission has developed technical standards for radio frequency equipment and parts or components thereof. The technical standards applicable to individual types of equipment are found in that part of the rules governing the service wherein the equipment is to be operated.¹ *In addition to the technical standards provided, the rules governing the service may require that such equipment be verified by the manufacturer or importer, be authorized under a Declaration of Conformity, or receive an equipment authorization from the Commission by one of the following procedures: certification or registration.*
- (b) The following sections describe the verification procedure, the procedure for a Declaration of Conformity, and the procedures to be followed in obtaining certification from the Commission and the conditions attendant to such a grant.

§ 2.907 Certification.

- (a) Certification is an equipment authorization issued by the Commission, based on representation and test data submitted by the applicant.
- (b) Certification attaches to all units subsequently marketed by the grantee which are identical (see Section 2.908) to the sample tested except for permissive changes or other variations authorized by the Commission pursuant to Section 2.1043.

¹ In this case, the equipment is subject to the rules of Part 15. More specifically, the equipment falls under Subpart B (of Part 15), which deals with unintentional radiators.

Certification & User's Manual Information

§ 2.948 Description of measurement facilities.

- (a) Each party making measurements of equipment that is subject to an equipment authorization under Part 15 or Part 18 of this chapter, regardless of whether the measurements are filed with the Commission or kept on file by the party responsible for compliance of equipment marketed within the U.S. or its possessions, shall compile a description of the measurement facilities employed.
- (1) If the measured equipment is subject to the verification procedure, the description of the measurement facilities shall be retained by the party responsible for verification of the equipment.
- (i) *If the equipment is verified through measurements performed by an independent laboratory, it is acceptable for the party responsible for verification of the equipment to rely upon the description of the measurement facilities retained by or placed on file with the Commission by that laboratory. In this situation, the party responsible for the verification of the equipment is not required to retain a duplicate copy of the description of the measurement facilities.*
- (ii) If the equipment is verified based on measurements performed at the installation site of the equipment, no specific site calibration data is required. It is acceptable to retain the description of the measurement facilities at the site at which the measurements were performed.
- (2) If the equipment is to be authorized by the Commission under the certification procedure, the description of the measurement facilities shall be filed with the Commission's Laboratory in Columbia, Maryland. The data describing the measurement facilities need only be filed once but must be updated as changes are made to the measurement facilities or as otherwise described in this section. At least every three years, the organization responsible for filing the data with the Commission shall certify that the data on file is current.

Certification & User's Manual Information

Label and User's Manual Information

The following is extracted from Title 47 of the Code of Federal Regulations, Part 15, Subpart A — General:

§ 15.19 Labeling requirements.

(a) *In addition to the requirements in Part 2 of this chapter, a device subject to certification or verification shall be labeled as follows:*

- (1) Receivers associated with the operation of a licensed radio service, e.g., FM broadcast under Part 73 of this chapter, land mobile operation under Part 90, etc., shall bear the following statement in a conspicuous location on the device:

This device complies with Part 15 of the FCC Rules. Operation is subject to the condition that this device does not cause harmful interference.

- (2) A stand-alone cable input selector switch, shall bear the following statement in a conspicuous location on the device:

This device is verified to comply with Part 15 of the FCC Rules for use with cable television service.

- (3) All other devices shall bear the following statement in a conspicuous location on the device:

This device complies with Part 15 of the FCC Rules. Operation is subject to the following two conditions: (1) This device may not cause harmful interference, and (2) this device must accept any interference received, including interference that may cause undesired operation.

- (4) Where a device is constructed in two or more sections connected by wires and marketed together, the statement specified under paragraph (a) of this section is required to be affixed only to the main control unit.

- (5) When the device is so small or for such use that it is not practicable to place the statement specified under paragraph (a) of this section on it, the information required by this paragraph shall be placed in a prominent location in the instruction manual or pamphlet supplied to the user or, alternatively, shall be placed on the container in which the device is marketed. However, the FCC identifier or the unique identifier, as appropriate, must be displayed on the device.

§ 15.21 Information to user.

The users manual or instruction manual for an intentional or unintentional radiator shall caution the user that changes or modifications not expressly approved by the party responsible for compliance could void the user's authority to operate the equipment.

Verification & User's Manual Information

The following is extracted from Title 47 of the Code of Federal Regulations, Part 15, Subpart B — Unintentional Radiators:

§ 15.105 Information to the user.

- (a) For a Class A digital device or peripheral, the instructions furnished the user shall include the following or similar statement, placed in a prominent location in the text of the manual:

Note: This equipment has been tested and found to comply with the limits for a Class A digital device, pursuant to Part 15 of the FCC Rules. These limits are designed to provide reasonable protection against harmful interference when the equipment is operated in a commercial environment. This equipment generates, uses, and can radiate radio frequency energy and, if not installed and used in accordance with the instruction manual, may cause harmful interference to radio communications. Operation of this equipment in a residential area is likely to cause harmful interference in which case the user will be required to correct the interference at own expense.

- (b) For a Class B digital device or peripheral, the instructions furnished the user shall include the following or similar statement, placed in a prominent location in the text of the manual:

Note: This equipment has been tested and found to comply with the limits for a Class B digital device, pursuant to Part 15 of the FCC Rules. These limits are designed to provide reasonable protection against harmful interference when the equipment is operated in a residential environment. This equipment generates, uses, and can radiate radio frequency energy and, if not installed and used in accordance with the instruction manual, may cause harmful interference to radio communications. However, there is no guarantee that interference will not occur in a particular installation. If this equipment does cause harmful interference to radio or television reception, which can be determined by turning the equipment off and on, the user is encouraged to try to correct the interference by one or more of the following measures:

- Reorient or relocate the receiving antenna.
- Increase the separation between the equipment and receiver.
- Connect the equipment into an outlet on a circuit different from that to which the receiver is connected.
- Consult the dealer or an experienced radio/TV technician for help.

ICES-003 Procedural & Labeling Requirements

From the Industry Canada Electromagnetic Compatibility Advisory Bulletin entitled, "Implementation and Interpretation of the Interference-Causing Equipment Standard for Digital Apparatus, ICES-003" (EMCAB-3, Issue 2, July 1995):

"At present, CISPR 22: 2002 and ICES technical requirements are essentially equivalent. Therefore, if you have CISPR 22: 2002 approval by meeting CISPR Publication 22, the only additional requirements are: to attach a note to the report of the test results for compliance, indicating that these results are deemed satisfactory evidence of compliance with ICES-003 of the Canadian Interference-Causing Equipment Regulations; to maintain these records on file for the requisite five year period; and to provide the device with a notice of compliance in accordance with ICES-003."

Procedural Requirements:

According to Industry Canada's Interference Causing Equipment Standard for Digital Apparatus ICES-003 Issue 4, February 2004:

- Section 6.1: A record of the measurements and results, showing the date that the measurements were completed, shall be retained by the manufacturer or importer for a period of at least five years from the date shown in the record and made available for examination on the request of the Minister.
- Section 6.2: A written notice indicating compliance must accompany each unit of digital apparatus to the end user. The notice shall be in the form of a label that is affixed to the apparatus. Where because of insufficient space or other constraints it is not feasible to affix a label to the apparatus, the notice may be in the form of a statement in the user's manual.

Labeling Requirements:

The suggested text for the notice, in English and in French, is provided below, from the Annex of ICES-003:

This Class [²] digital apparatus complies with Canadian ICES-003.

Cet appareil numérique de la classe [¹] est conforme à la norme NMB-003 du Canada.

² Insert either A or B but not both as appropriate for the equipment requirements.

End of Report