



**MET Laboratories, Inc.** *Safety Certification - EMI - Telecom Environmental Simulation*

914 WEST PATAPSCO AVENUE • BALTIMORE, MARYLAND 21230-3432 • PHONE (410) 354-3300 • FAX (410) 354-3313  
33439 WESTERN AVENUE • UNION CITY, CALIFORNIA 94587 • PHONE (510) 489-6300 • FAX (510) 489-6372  
3162 BELICK STREET • SANTA CLARA, CALIFORNIA 95054 • PHONE (408) 748-3585 • FAX (510) 489-6372  
13501 MCCALLEN PASS • AUSTIN, TX 78753 • PHONE (512) 287-2500 • FAX (512) 287-2513

February 20, 2017

Firetide, Inc.  
2105 South Bascom Avenue  
Suite 220  
Campbell, CA 95008

Dear Sudhir Hirudayaraj,

Enclosed is the EMC Wireless test report for compliance testing of the Firetide, Inc., 7010(W) as tested to the requirements of Title 47 of the CFR, Ch. 1 (10-1-06 ed.), Title 47 of the CFR, Part 15.407, Subpart E (UNII 3).

Thank you for using the services of MET Laboratories, Inc. If you have any questions regarding these results or if MET can be of further service to you, please feel free to contact me.

Sincerely yours,  
MET LABORATORIES, INC.

Joel Huna  
Documentation Department

Reference: (\Firetide, Inc.\EMC92597-FCC407 UNII 3 Rev. 1)

Certificates and reports shall not be reproduced except in full, without the written permission of MET Laboratories, Inc.



**MET Laboratories, Inc.** *Safety Certification - EMI - Telecom Environmental Simulation*

914 WEST PATAPSCO AVENUE • BALTIMORE, MARYLAND 21230-3432 • PHONE (410) 354-3300 • FAX (410) 354-3313

33439 WESTERN AVENUE • UNION CITY, CALIFORNIA 94587 • PHONE (510) 489-6300 • FAX (510) 489-6372

3162 BELICK STREET • SANTA CLARA, CALIFORNIA 95054 • PHONE (408) 748-3585 • FAX (510) 489-6372

13501 MCCALLEN PASS • AUSTIN, TX 78753 • PHONE (512) 287-2500 • FAX (512) 287-2513

**Electromagnetic Compatibility Criteria  
Test Report**

for the

**Firetide, Inc.  
Model 7010(W)**

**Tested under**  
The FCC Certification Rules  
contained in  
Title 47 of the CFR  
15.407 Subpart E

**MET Report: EMCS92597-FCC407 UNII 3 Rev. 1**

February 20, 2017

**Prepared For:**

**Firetide, Inc.  
2105 South Bascom Avenue  
Suite 220  
Campbell, CA 95008**

**Prepared By:**  
**MET Laboratories, Inc.**  
3162 Belick St.  
Santa Clara, CA 95054

## Electromagnetic Compatibility Criteria Test Report

for the

**Firetide, Inc.**  
**Model 7010(W)**

**Tested under**  
The FCC Certification Rules  
contained in  
Title 47 of the CFR  
15.407 Subpart E



Jun Qi, Project Engineer  
Electromagnetic Compatibility Lab



Joel Huna  
Documentation Department

**Engineering Statement:** The measurements shown in this report were made in accordance with the procedures indicated, and the emissions from this equipment were found to be within the limits applicable. I assume full responsibility for the accuracy and completeness of these measurements, and for the qualifications of all persons taking them. It is further stated that upon the basis of the measurements made, the equipment tested is capable of operation in accordance with the requirements of Parts 15B, 15.407, of the FCC Rules under normal use and maintenance.



Asad Bajwa,  
Director, Electromagnetic Compatibility Lab

## Report Status Sheet

Revision	Report Date	Reason for Revision
∅	February 3, 2017	Initial Issue.
1	February 20, 2017	Engineer corrections.

## Table of Contents

<b>I.</b>	<b>Executive Summary .....</b>	<b>1</b>
	A. Purpose of Test .....	2
	B. Executive Summary .....	2
<b>II.</b>	<b>Equipment Configuration .....</b>	<b>3</b>
	A. Overview.....	4
	B. References.....	5
	C. Test Site .....	5
	D. Description of Test Sample.....	5
	E. Equipment Configuration.....	7
	F. Support Equipment .....	7
	G. Ports and Cabling Information.....	7
	H. Mode of Operation.....	8
	I. Method of Monitoring EUT Operation .....	8
	J. Modifications .....	8
	a) Modifications to EUT .....	8
	b) Modifications to Test Standard .....	8
	K. Disposition of EUT .....	8
<b>III.</b>	<b>Electromagnetic Compatibility Criteria for Intentional Radiators.....</b>	<b>9</b>
	§ 15.203 Antenna Requirement.....	10
	§ 15.407(a)(3) Maximum Conducted Output Power .....	11
	§ 15.407(a)(3) Maximum Power Spectral Density .....	15
	§ 15.407(b)(4) & (6 - 7) Undesirable Emissions .....	19
	§ 15.407(b)(6) Conducted Emissions .....	40
	§ 15.407(c) Automatic Discontinue of Transmission .....	43
	§ 15.407(e) 6 dB Bandwidth.....	44
	§ 15.247(i) Maximum Permissible Exposure .....	48
	§ 15.407(g) Frequency Stability .....	50
<b>IV.</b>	<b>Test Equipment .....</b>	<b>51</b>
<b>V.</b>	<b>Certification &amp; User's Manual Information.....</b>	<b>53</b>
	A. Certification Information .....	54
	B. Label and User's Manual Information .....	58

## List of Tables

Table 1. Executive Summary of EMC Part 15.407 Compliance Testing .....	2
Table 2. EUT Summary.....	4
Table 3. References .....	5
Table 4. Equipment Configuration .....	7
Table 5. Support Equipment.....	7
Table 6. Ports and Cabling Information .....	7
Table 7. Maximum Conducted Output Power, 20 MHz, Peak Conducted Output Power.....	12
Table 8. Maximum Conducted Output Power, 20 MHz, Summed Peak Conducted Output Power.....	13
Table 9. Maximum Conducted Output Power, 40 MHz, Peak Conducted Output Power.....	13
Table 10. Maximum Conducted Output Power, 40 MHz, Summed Peak Conducted Output Power.....	14
Table 11. Power Spectral Density, 20 MHz.....	16
Table 12. Power Spectral Density, 20 MHz, Summed Power Spectral Density.....	17
Table 13. Power Spectral Density, 40 MHz.....	17
Table 14. Power Spectral Density, 40 MHz, Summed Power Spectral Density.....	18
Table 15. Conducted Limits for Intentional Radiators from FCC Part 15 § 15.207(a) .....	40
Table 16. Conducted Emissions, 15.407(b)(6), Line 1, Test Results .....	41
Table 17. Conducted Emissions, 15.407(b)(6), Neutral, Test Results.....	42
Table 18. Occupied Bandwidth, 20 MHz, Test Results.....	44
Table 19. Occupied Bandwidth, 40 MHz Test Results .....	45
Table 20. RF Exposure, FCC, UNII 3, 16 dBi .....	48
Table 21. RF Exposure, FCC, UNII 3, 19 dBi .....	49
Table 22. RF Exposure, FCC, UNII 3, 9 dBi .....	49
Table 23. Test Equipment List .....	52

## List of Figures

Figure 1. Block Diagram of Test Configuration.....	6
--	---

## List of Plots

Plot 1. Radiated Spurious Emissions, 11n, 40 MHz, Low , 5755 MHz, Average 9 dBi .....	20
Plot 2. Radiated Spurious Emissions, 11n, 40 MHz, High, 5795 MHz, Average 9 dBi.....	20
Plot 3. Radiated Spurious Emissions, 11n, 40 MHz, Low, 5755 MHz, Average 16 dBi .....	21
Plot 4. Radiated Spurious Emissions, 11n, 40 MHz, High, 5795 MHz, Average 16 dBi.....	21
Plot 5. Radiated Spurious Emissions, 11n, 40 MHz, Low, 5755 MHz, Average 19 dBi.....	22
Plot 6. Radiated Spurious Emissions, 11n, 40 MHz, Low, 5795 MHz, Average 19 dBi .....	22
Plot 7. Radiated Spurious Emissions, No radiate, Power on only .....	23
Plot 8. Radio Spurious Emission, 1 GHz - 18 GHz - 27 dBm, Bandwidth 40M, Ch. 5795M, n mode, 9 dBi .....	24
Plot 9. Radio Spurious Emission, 1 GHz - 18 GHz - 27 dBm, Bandwidth 40M, Ch. 5755M, n mode, 9dBi .....	24
Plot 10. Radio Spurious Emission, 1 GHz - 18 GHz - 27 dBm, Bandwidth 20M, Ch. 5805M, n mode, 9 dBi .....	24
Plot 11. Radio Spurious Emission, 1 GHz - 18 GHz - 27 dBm, Bandwidth 20M, Ch. 5805M, a mode, 9 dBi.....	25
Plot 12. Radio Spurious Emission, 1 GHz - 18 GHz - 27 dBm, Bandwidth 20M, Ch. 5785M, n mode, 9 dBi .....	25
Plot 13. Radio Spurious Emission, 1 GHz - 18 GHz - 27 dBm, Bandwidth 20M, Ch. 5785M, a mode, 9 dBi.....	25
Plot 14. Radio Spurious Emission, 1 GHz - 18 GHz - 27 dBm, Bandwidth 20M, Ch. 5745M, a mode, 9 dBi.....	26
Plot 15. Radio Spurious Emission, 1 GHz - 18 GHz - 27 dBm, Bandwidth 20M, Ch. 5745M, a mode, 9 dBi.....	26
Plot 16. Radio Spurious Emission, 1 GHz - 18 GHz - 27 dBm, Bandwidth 40M, Ch. 5795M, n mode, 16 dBi .....	26
Plot 17. Radio Spurious Emission, 1 GHz - 18 GHz - 27 dBm, Bandwidth 40M, Ch. 5755M, n mode, 16 dBi .....	27
Plot 18. Radio Spurious Emission, 1 GHz - 18 GHz - 27 dBm, Bandwidth 20M, Ch. 5805M, n mode, 16 dBi .....	27
Plot 19. Radio Spurious Emission, 1 GHz - 18 GHz - 27 dBm, Bandwidth 20M, Ch. 5805M, a mode, 16 dBi.....	27
Plot 20. Radio Spurious Emission, 1 GHz - 18 GHz - 27 dBm, Bandwidth 20M, Ch. 5785M, n mode, 16 dBi .....	28

Plot 21. Radio Spurious Emission, 1 GHz - 18 GHz - 27 dBm, Bandwidth 20M, Ch. 5785M, a mode, 16 dBi.....	28
Plot 22. Radio Spurious Emission, 1 GHz - 18 GHz - 27 dBm, Bandwidth 20M, Ch. 5745M, n mode, 16 dBi .....	28
Plot 23. Radio Spurious Emission, 1 GHz - 18 GHz - 27 dBm, Bandwidth 20M, Ch. 5745M, a mode, 16 dBi.....	29
Plot 24. Radio Spurious Emission, 1 GHz - 18 GHz - 27dBm, Bandwidth 40M, Ch. 5795M, n mode, 19 dBi .....	29
Plot 25. Radio Spurious Emission, 1 GHz - 18 GHz - 27dBm, Bandwidth 40M, Ch. 5755M, n mode, 19 dBi .....	29
Plot 26. Radio Spurious Emission, 1 GHz - 18 GHz -27 dBm, Bandwidth 20M, Ch.5805M, n mode, 19 dBi .....	30
Plot 27. Radio Spurious Emission, 1 GHz - 18 GHz -27 dBm, Bandwidth 20M, Ch. 5805M, a mode, 19 dBi.....	30
Plot 28. Radio Spurious Emission, 1 GHz - 18 GHz -27 dBm, Bandwidth 20M, Ch. 5785M, n mode, 19 dBi .....	30
Plot 29. Radio Spurious Emission, 1 GHz - 18 GHz -27 dBm, Bandwidth 20M, Ch. 5785M, a mode, 19 dBi.....	31
Plot 30. Radio Spurious Emission, 1 GHz - 18 GHz -27 dBm, Bandwidth 20M, Ch. 5745M, n mode, 19 dBi .....	31
Plot 31. Radio Spurious Emission, 1 GHz - 18 GHz -27 dBm, Bandwidth 20M, Ch. 5745M, a mode, 19 dBi.....	31
Plot 32. UNII-3 Mask, 11n, 40MHz, 5795M, 9 dBi.....	32
Plot 33. UNII-3 Mask, 11n, 40MHz, 5755MHz, 9 dBi .....	32
Plot 34. UNII-3 Mask, 11n, 20MHz, 5805M, 9 dBi.....	32
Plot 35. UNII-3 Mask, 11n, 20MHz, 5785MHz, 9 dBi .....	33
Plot 36. UNII-3 Mask, 11n, 20MHz, 5745MHz, 9 dBi .....	33
Plot 37. UNII-3 Mask, 11a, 20MHz, 5805MHz, 9 dBi .....	33
Plot 38. UNII-3 Mask, 11a, 20MHz, 5785 MHz, 9 dBi .....	34
Plot 39. UNII-3 Mask, 11a, 20MHz, 5745 MHz, 9 dBi .....	34
Plot 40. UNII-3 Mask, 11n, 40 MHz, 5795 MHz, 16 dBi.....	34
Plot 41. UNII-3 Mask, 11n, 40 MHz, 5755 MHz, 16 dBi.....	35
Plot 42. UNII-3 Mask, 11n, 20 MHz, 5805 MHz, 16 dBi.....	35
Plot 43. UNII-3 Mask, 11n, 20 MHz, 5785 MHz, 16 dBi.....	35
Plot 44. UNII-3 Mask, 11n, 20 MHz, 5745 MHz, 16 dBi.....	36
Plot 45. UNII-3 Mask, 11a, 20 MHz, 5805 MHz, 16 dBi .....	36
Plot 46. UNII-3 Mask, 11a, 20 MHz, 5785 MHz, 16 dBi .....	36
Plot 47. UNII-3 Mask, 11a, 20 MHz,5745 MHz, 16 dBi .....	37
Plot 48. UNII-3 Mask, 11n, 40 MHz, 5795 MHz, 19 dBi.....	37
Plot 49. UNII-3 Mask, 11n, 40 MHz, 5755 MHz, 19 dBi.....	37
Plot 50. UNII-3 Mask, 11n, 20 MHz, 5805 MHz, 19 dBi.....	38
Plot 51. UNII-3 Mask, 11n, 20 MHz, 5785 MHz, 19 dBi.....	38
Plot 52. UNII-3 Mask, 11n, 20 MHz, 5745 MHz , 19 dBi.....	38
Plot 53. UNII-3 Mask, 11a, 20 MHz, 5805 MHz, 19 dBi .....	39
Plot 54. UNII-3 Mask, 11a, 20 MHz, 5785 MHz, 19 dBi .....	39
Plot 55. UNII-3 Mask, 11a, 20 MHz, 5745 MHz, 19 dBi .....	39
Plot 56. Conducted Emissions, Line 1 (Radio On).....	41
Plot 57. Conducted Emissions, Neutral Line (Radio On).....	42
Plot 58. 6 dB Occupied Bandwidth, 802.11a, 20 MHz, Ch. 5745 MHz, R11 .....	45
Plot 59. 6 dB Occupied Bandwidth, 802.11a, 20 MHz, Ch. 5785 MHz, R11 .....	45
Plot 60. 6 dB Occupied Bandwidth, 802.11a, 20 MHz, Ch. 5805 MHz, R11 .....	46
Plot 61. 6 dB Occupied Bandwidth, 802.11a, 20 MHz, Ch. 5745 MHz, R11 .....	46
Plot 62. 6 dB Occupied Bandwidth, 802.11a, 20 MHz, Ch. 5785 MHz, R11 .....	46
Plot 63. 6 dB Occupied Bandwidth, 802.11a, 20 MHz, Ch. 5805 MHz, R11 .....	47
Plot 64. 6 dB Occupied Bandwidth, 802.11a, 40 MHz, Ch. 5755 MHz, R11 .....	47
Plot 65. 6 dB Occupied Bandwidth, 802.11a, 40 MHz, Ch. 5795 MHz, R11 .....	47

## List of Terms and Abbreviations

<b>AC</b>	<b>Alternating Current</b>
<b>ACF</b>	<b>Antenna Correction Factor</b>
<b>Cal</b>	<b>Calibration</b>
<i>d</i>	<b>Measurement Distance</b>
<b>dB</b>	<b>Decibels</b>
<b>dB<math>\mu</math>A</b>	<b>Decibels above one microamp</b>
<b>dB<math>\mu</math>V</b>	<b>Decibels above one microvolt</b>
<b>dB<math>\mu</math>A/m</b>	<b>Decibels above one microamp per meter</b>
<b>dB<math>\mu</math>V/m</b>	<b>Decibels above one microvolt per meter</b>
<b>DC</b>	<b>Direct Current</b>
<b>E</b>	<b>Electric Field</b>
<b>DSL</b>	<b>Digital Subscriber Line</b>
<b>ESD</b>	<b>Electrostatic Discharge</b>
<b>EUT</b>	<b>Equipment Under Test</b>
<i>f</i>	<b>Frequency</b>
<b>FCC</b>	<b>Federal Communications Commission</b>
<b>GRP</b>	<b>Ground Reference Plane</b>
<b>H</b>	<b>Magnetic Field</b>
<b>HCP</b>	<b>Horizontal Coupling Plane</b>
<b>Hz</b>	<b>Hertz</b>
<b>IEC</b>	<b>International Electrotechnical Commission</b>
<b>kHz</b>	<b>Kilohertz</b>
<b>kPa</b>	<b>Kilopascal</b>
<b>kV</b>	<b>Kilovolt</b>
<b>LISN</b>	<b>Line Impedance Stabilization Network</b>
<b>MHz</b>	<b>Megahertz</b>
<b><math>\mu</math>H</b>	<b>Microhenry</b>
<b><math>\mu</math></b>	<b>Microfarad</b>
<b><math>\mu</math>s</b>	<b>Microseconds</b>
<b>PRF</b>	<b>Pulse Repetition Frequency</b>
<b>RF</b>	<b>Radio Frequency</b>
<b>RMS</b>	<b>Root-Mean-Square</b>
<b>TWT</b>	<b>Traveling Wave Tube</b>
<b>V/m</b>	<b>Volts per meter</b>
<b>VCP</b>	<b>Vertical Coupling Plane</b>



# I. Executive Summary

## A. Purpose of Test

An EMC evaluation was performed to determine compliance of the Firetide, Inc. 7010(W), with the requirements of Part 15, §15.407. All references are to the most current version of Title 47 of the Code of Federal Regulations in effect. In accordance with §2.1033, the following data is presented in support of the Certification of the 7010(W). Firetide, Inc. should retain a copy of this document which should be kept on file for at least two years after the manufacturing of the 7010(W), has been **permanently** discontinued.

## B. Executive Summary

The following tests were conducted on a sample of the equipment for the purpose of demonstrating compliance with Part 15, §15.407, in accordance with Firetide, Inc., purchase order number PO-3987. All tests were conducted using measurement procedure ANSI C63.4-2014 and ANSI C63.10-2013.

FCC Reference	Description	Results
§15.203	Antenna Requirement	Compliant
§15.407 (a)(3)	Maximum Conducted Output Power	Compliant
§15.407 (a)(3)	Maximum Power Spectral Density	Compliant
§15.407 (b)(4)& (6 - 7)	Undesirable Emissions	Compliant
§15.407(b)(6)	Conducted Emission Limits	Compliant
§15.407(c)	Automatic Discontinue of Transmitter	Not Applicable
§15.407(e)	6 dB Bandwidth	Compliant
§15.407(f)	RF Exposure	Compliant
§15.407(g)	Frequency Stability	Not Applicable

**Table 1. Executive Summary of EMC Part 15.407 Compliance Testing**

## II. Equipment Configuration

## A. Overview

MET Laboratories, Inc. was contracted by Firetide, Inc. to perform testing on the 7010(W), under Firetide, Inc.'s purchase order number PO-3987.

This document describes the test setups, test methods, required test equipment, and the test limit criteria used to perform compliance testing of the Firetide, Inc. 7010(W).

The results obtained relate only to the item(s) tested.

<b>Model(s) Tested:</b>	7010(W)	
<b>Model(s) Covered:</b>	7010(W)	
<b>EUT Specifications:</b>	Primary Power: 115VAC	
	FCC ID: REP-7100-W	
	Type of Modulations:	OFDM
	Equipment Code:	NII
	Max. RF Output Power:	26.57 dBm @5795MHz
	EUT Frequency Ranges:	5745MHz – 5825Hz
<b>Analysis:</b>	The results obtained relate only to the item(s) tested.	
<b>Environmental Test Conditions:</b>	Temperature: 15-35° C	
	Relative Humidity: 30-60%	
	Barometric Pressure: 860-1060 mbar	
<b>Evaluated by:</b>	Jun Qi	
<b>Report Date(s):</b>	February 20, 2017	

**Table 2. EUT Summary**

## B. References

<b>CFR 47, Part 15, Subpart E</b>	Unlicensed National Information Infrastructure Devices (UNII)
<b>ANSI C63.4:2014</b>	Methods and Measurements of Radio-Noise Emissions from Low-Voltage Electrical And Electronic Equipment in the Range of 9 kHz to 40 GHz
<b>ISO/IEC 17025:2005</b>	General Requirements for the Competence of Testing and Calibration Laboratories
<b>ANSI C63.10-2013</b>	American National Standard for Testing Unlicensed Wireless Devices

**Table 3. References**

## C. Test Site

All testing was performed at MET Laboratories, Inc., 3162 Belick St. Santa Clara, CA 95054. All equipment used in making physical determinations is accurate and bears recent traceability to the National Institute of Standards and Technology.

Radiated Emissions measurements were performed in a 5 meter semi-anechoic chamber (equivalent to an Open Area Test Site). In accordance with §2.948(a)(3), a complete site description is contained at MET Laboratories.

## D. Description of Test Sample

The Firetide, Inc. 7010(W), Equipment Under Test (EUT), is a Firetide Mesh Network. A Firetide Mesh Network which is composed of two or more Mesh Nodes, gives you the convenience of a wired- Ethernet switch combined with the deployment flexibility of wireless technology. Each Mesh Node in the network can accept a wired Ethernet connection. That connection's Ethernet data is sent wirelessly to another Mesh Node. If the receiving Mesh Node is connected to the wired destination for the data packet, the Node routes that packet to its Ethernet connection. If it is not the final destination, the packet is forwarded wirelessly to the next Mesh Node and ultimately to its final destination.

Depending on the network topology, a Mesh Node can be set up to operate as a point to point device (in which directional antennas would be used) or as a point to multipoint device (in which a combination of omnidirectional and directional antennas would be used). The Radio technology incorporated into the Mesh Node is based on the 802.11a/b/g/n standard. The Radio can be configured to operate in standard 802.11g mode or 802.11n mode, referred to as MIMO.

The HotPort Node is housed in a weatherized, cast aluminum enclosure. External antennas connect to the four type N connectors (two per radio 2x2), two on each side of the enclosure.

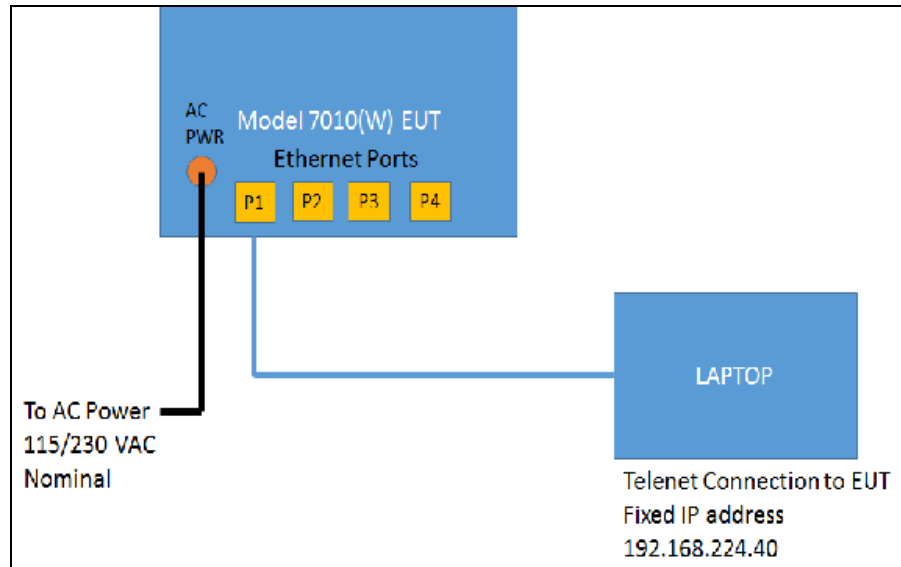

**Figure 1. Block Diagram of Test Configuration**

## Equipment Configuration

The EUT was set up as outlined in Figure 1, Block Diagram of Test Setup. All cards, racks, etc., incorporated as part of the EUT is included in the following list.

Ref. ID	Slot #	Name / Description	Model Number	Part Number	Serial Number	Rev. #
1		HOTPORT Out Door Mesh Node	7010(W)	7010(W)		1.0

**Table 4. Equipment Configuration**

## E. Support Equipment

Support equipment necessary for the operation and testing of the EUT is included in the following list.

Ref. ID	Name / Description	Manufacturer	Model Number	*Customer Supplied Calibration Data
1	5.125 to 6.1G,3xN,19dBi Panel Antenna	Firetide	AP-20-050-MIMO-19	N/A
2	4.9 to 6.1 GHZ3xN,16dBi Sector	Firetide	AS90-050-MIMO-16T	N/A
3	5.15 to 5.85G,3 Port,8dBi Omini	Firetide	AO-050-MIMO-9	N/A
4	2.3 to 2.7G,2xN,13dBi Panel	Firetide	AS90-024-MIMO-13	N/A
5	2.4 to 2.5G,3 Port,9dBi,Omini	Firetide	AO-024-MIMO-8	N/A
6	5G,5dBi Omini (used for DFS)	WHA Yu	C812510010-A	N/A
7	5G,5dBi Omini(used for DFS)	WHA Yu	C812510012-A	N/A

The 'Customer Supplied Calibration Data' column will be marked as either not applicable, not available, or will contain the calibration date supplied by the customer.

**Table 5. Support Equipment**

## F. Ports and Cabling Information

Ref. ID	Port name on EUT	Cable Description or reason for no cable	Qty	Length as tested (m)	Shielded? (Y/N)	Termination Box ID & Port Name
1	Antenna Ports, Radio1: Ant1, Ant2 Radio2: Ant1, Ant2	CB-C-015-N(LMR400)	4	1.5Meter	Yes	Antenna Ports
2	Power Input Port: AC	Power cord, 3 conductor, 18 awg	1		Yes	AC: Power Input Port (115v/60hz)
3	Port1 ... Port4 (P1...P4)	CAT 5E Ethernet cable	1	2 Meter	N	Port1 ... Port4

**Table 6. Ports and Cabling Information**

## **G. Mode of Operation**

HotPort 7010(W)

Once the AC power/POE Power is applied LED indicates to mention that the 7010(W) unit is powered on properly. . Proper IP address should be set in the PC prior to the Ethernet cable connection. The Ethernet connectivity needs to be made by connecting an Ethernet cable. Once the connection is established, you can verify this in the PC's LAN connectivity status. Proper IP address should be set in the PC prior to the Ethernet cable connection

## **H. Method of Monitoring EUT Operation**

HotPort 7010(W)

Mechanical Dimension: Dimensions: 13.4" X 9.3" X 4.7"Outdoor

Electrical Indication: Power and Status LED's on the front panel To verify whether the EUT is power ON , if the EUT is ON the Power LED will glow Green

Status LED Glows when the firmware is up. When the unit meshes with another unit using single radio configuration Radio1 LED will glow and when the unit meshes with another unit with dual radio configuration both Radio 1 and Radio 2 LED will glow.

With the Ethernet cable connected to PC or Laptop Ping the EUT with the IP address 192.168.224.xxx (150) for 7010(W)

## **I. Modifications**

### **a) Modifications to EUT**

No modifications were made to the EUT.

### **b) Modifications to Test Standard**

No modifications were made to the test standard.

## **J. Disposition of EUT**

The test sample including all support equipment submitted to the Electro-Magnetic Compatibility Lab for testing was returned to Firetide, Inc. upon completion of testing.



### **III. Electromagnetic Compatibility Criteria for Intentional Radiators**

## Electromagnetic Compatibility Criteria for Intentional Radiators

### § 15.203                      Antenna Requirement

**Test Requirement:**            § 15.203: An intentional radiator shall be designed to ensure that no antenna other than that furnished by the responsible party shall be used with the device. The use of a permanently attached antenna or of an antenna that uses a unique coupling to the intentional radiator shall be considered sufficient to comply with the provisions of this section. The manufacturer may design the unit so that a broken antenna can be replaced by the user, but the use of a standard antenna jack or electrical connector is prohibited.

The structure and application of the EUT were analyzed to determine compliance with Section 15.203 of the Rules. Section 15.203 states that the subject device must meet at least one of the following criteria:

- a.) Antenna must be permanently attached to the unit.
- b.) Antenna must use a unique type of connector to attach to the EUT.
- c.) Unit must be professionally installed. Installer shall be responsible for verifying that the correct antenna is employed with the unit.

**Results:**                              The EUT as tested is compliant C the criteria of §15.203.

Unit must be professionally installed. Installer shall be responsible for verifying that the correct antenna is employed with the unit.

**Test Engineer(s):**                Jun Qi

**Test Date(s):**                      November 30, 2017

## Electromagnetic Compatibility Criteria for Intentional Radiators

### §15.407(a)(3) Maximum Conducted Output Power

**Test Requirements:** §15.407(a)(3): For the band 5.725-5.85 GHz, the maximum conducted output power over the frequency band of operation shall not exceed 1 W.  
If transmitting antennas of directional gain greater than 6 dBi are used, both the maximum conducted output power and the maximum power spectral density shall be reduced by the amount in dB that the directional gain of the antenna exceeds 6 dBi. However, fixed point-to-point U-NII devices operating in this band may employ transmitting antennas with directional gain greater than 6 dBi without any corresponding reduction in transmitter conducted power.

**Test Procedure:** The EUT was connected to a spectrum analyzer through a cable and attenuator. Measurements were taken with the EUT set to transmit continuously on its low, mid, and high channels. Its power was measured according to measurement method SA-1, as described in 789033 D02 General UNII Test Procedures v01.

Limit calculation:  $\text{limit} = 30 - (\text{Ga} - 6)$

Limit Power<sub>19dBi</sub> =  $30 - (19 - 6) = 17 \text{ dBm}$

Limit Power<sub>16dBi</sub> =  $30 - (16 - 6) = 20 \text{ dBm}$

Limit Power<sub>9dBi</sub> =  $30 - (9 - 6) = 27 \text{ dBm}$

**Test Results:** The EUT as tested is compliant with the requirements of this section.

No anomalies detected..

**Test Engineer(s):** Saeed Kabirsalmani

**Test Date(s):** November 18, 2016

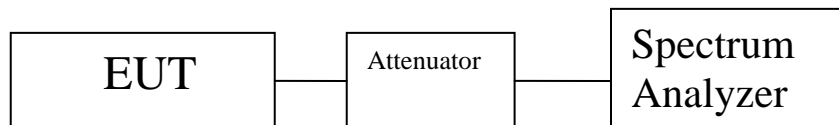

Peak Conducted Output Power					
	Channel	Frequency (MHz)	Measured Peak Power (dBm)		
Gain			19dBi	16dBi	9dBi
802.11a 20MHz Port R11	Low	5745	10.68	13.73	20.1
	Mid	5785	10.79	13.29	20.82
	High	5805	10.82	13.41	20.53
802.11a 20 MHz Port R12	Low	5745	10.53	13.88	20.66
	Mid	5785	10.72	13.51	20.44
	High	5805	10.91	13.83	20.69
802.11a 20MHz Port R21	Low	5745	10.50	13.26	20.18
	Mid	5785	10.86	12.96	20.07
	High	5805	10.92	12.81	20.41
802.11a 20 MHz Port R22	Low	5745	10.48	13.64	20.95
	Mid	5785	10.42	13.07	20.39
	High	5805	10.64	13.4	20.54
802.11n 20MHz Port R11	Low	5745	10.98	13.54	20.66
	Mid	5785	10.86	13.05	20.09
	High	5805	10.82	13.26	20.03
802.11n 20 MHz Port R12	Low	5745	10.66	13.41	20.49
	Mid	5785	10.69	13.19	20.01
	High	5805	10.49	13.56	20.09
802.11n 20MHz Port R21	Low	5745	10.78	13.74	20.95
	Mid	5785	10.79	13.17	20.42
	High	5805	10.83	13.29	20.56
802.11n 20 MHz Port R22	Low	5745	10.46	13.61	20.87
	Mid	5785	10.67	13.02	20.61
	High	5805	10.91	13.38	20.92

**Table 7. Maximum Conducted Output Power, 20 MHz, Peak Conducted Output Power**

Summed Peak Conducted Output Power					
Gain	Channel	Frequency (MHz)	Measured Peak Power (dBm)		
			19dBi	16dBi	9dBi
802.11a 20 MHz Summed	Low	5745	16.57	19.65	26.51
	Mid	5785	16.72	19.23	26.46
	High	5805	16.84	19.40	26.56
802.11n 20 MHz Summed	Low	5745	16.74	19.60	26.77
	Mid	5785	16.77	19.13	26.31
	High	5805	16.79	19.39	26.44
Limit			17	20	27

**Table 8. Maximum Conducted Output Power, 20 MHz, Summed Peak Conducted Output Power**

Peak Conducted Output Power					
Gain	Channel	Frequency (MHz)	Measured Peak Power (dBm)		
			19dBi	16dBi	9dBi
802.11n 40MHz Port R11	Low	5755	10.10	13.68	20.31
	High	5795	10.95	13.43	20.05
802.11n 40 MHz Port R12	Low	5755	8.14	13.3	20.05
	High	5795	10.12	13.81	20.58
802.11n 40MHz Port R21	Low	5755	10.98	13.32	20.65
	High	5795	10.17	13.54	20.71
802.11n 40 MHz Port R22	Low	5755	10.16	13.67	20.49
	High	5795	10.43	13.5	20.8

**Table 9. Maximum Conducted Output Power, 40 MHz, Peak Conducted Output Power**

Summed Peak Conducted Output Power					
	Channel	Frequency (MHz)	Measured Peak Power (dBm)		
Gain			19dBi	16dBi	9dBi
802.11n 40 MHz Summed	Low	5755	15.98	19.52	26.40
	High	5795	16.45	19.59	26.57
Limit			17	20	27

**Table 10. Maximum Conducted Output Power, 40 MHz, Summed Peak Conducted Output Power**

## Electromagnetic Compatibility Criteria for Intentional Radiators

### §15.407(a)(3) Maximum Power Spectral Density

**Test Requirements:** §15.407(a)(3): In addition, the maximum power spectral density shall not exceed 30 dBm in any 500-kHz band.

If transmitting antennas of directional gain greater than 6 dBi are used, both the maximum conducted output power and the maximum power spectral density shall be reduced by the amount in dB that the directional gain of the antenna exceeds 6 dBi. However, fixed point-to-point U-NII devices operating in this band may employ transmitting antennas with directional gain greater than 6 dBi without any corresponding reduction in transmitter conducted power.

**Test Procedure:** The EUT was connected to a spectrum analyzer through a cable and attenuator. Measurements were taken with the EUT set to transmit continuously on its low, mid, and high channels. Its power was measured according KDB 789033 D02 General UNII Test Procedures v01. A 1 MHz RBW was used during testing, as this provides a worst-case scenario.

**Limit calculation: limit = 30 – (Ga -6)**  
**Limit PSD19dBi = 30 – ( 19 – 6 ) = 17 dBm**  
**Limit PSD16dBi = 30 – ( 16 – 6 ) = 20 dBm**  
**Limit PSD9dBi = 30 – ( 9 – 6 ) = 27 dBm**

**Test Results:** The EUT as tested is compliant with the requirements of this section.

No anomalies detected.

**Test Engineer(s):** Saeed Kabirsalmani

**Test Date(s):** November 18, 2016

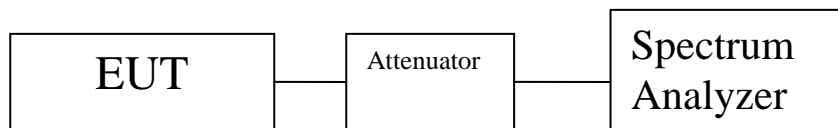

PSD					
	Channel	Frequency (MHz)	Measured PSD(dBm)		
Gain			19dBi	16dBi	9dBi
802.11a 20MHz Port R11	Low	5745	-6.52	-4.95	1.61
	Mid	5785	-7.03	-5.31	1.52
	High	5805	-7.39	-5.39	1.35
802.11a 20 MHz Port R12	Low	5745	-10.39	-4.96	2.64
	Mid	5785	-9.95	-5.12	2.45
	High	5805	-9.78	-4.94	2.34
802.11a 20MHz Port R21	Low	5745	-7.56	-5.61	2.38
	Mid	5785	-7.85	-5.32	1.85
	High	5805	-7.65	-5.18	2.18
802.11a 20 MHz Port R22	Low	5745	-6.62	-5.03	2.52
	Mid	5785	-8.25	-4.87	2.22
	High	5805	-8.13	-6.11	2.48
802.11n 20MHz Port R11	Low	5745	-6.77	-5.41	2.48
	Mid	5785	-7.34	-5.56	2.01
	High	5805	-7.06	-5.13	2.09
802.11n 20 MHz Port R12	Low	5745	-10.49	-5.95	1.71
	Mid	5785	-10.08	-5.12	1.55
	High	5805	-10.39	-5.87	1.36
802.11n 20MHz Port R21	Low	5745	-7.88	-5.32	2.48
	Mid	5785	-7.66	-4.95	1.95
	High	5805	-7.71	-4.85	1.86
802.11n 20 MHz Port R22	Low	5745	-8.41	-4.54	1.52
	Mid	5785	-8.39	-6.19	1.38
	High	5805	-7.60	-5.19	2.31

**Table 11. Power Spectral Density, 20 MHz**

\*Note: According to 15.247 KDB, measurement RBW is **100 KHz** while Limit is 30dBm/500KHz. So limits should be divided by 5 to be compared with 100 KHz RBW measurement



Summed PSD					
	Channel	Frequency (MHz)	Measured PSD (dBm)		
Gain			19dB <sub>i</sub>	16dB <sub>i</sub>	9dB <sub>i</sub>
802.11a 20 MHz Summed	Low	5745	-1.50	0.89	8.33
	Mid	5785	-2.13	0.87	8.05
	High	5805	-2.12	0.64	8.13
802.11n 20 MHz Summed	Low	5745	-2.17	0.75	8.09
	Mid	5785	-2.23	0.59	7.75
	High	5805	-2.00	0.78	7.94
Limit			17	20	27

**Table 12. Power Spectral Density, 20 MHz, Summed Power Spectral Density**

PSD					
	Channel	Frequency (MHz)	Measured PSD(dBm)		
Gain			19dB <sub>i</sub>	16dB <sub>i</sub>	9dB <sub>i</sub>
802.11n 40MHz Port R11	Low	5755	-11.59	-8.98	-1.48
	High	5795	-10.23	-8.33	-2.19
802.11n 40 MHz Port R12	Low	5755	-12.88	-9.55	-2.37
	High	5795	-10.93	-8.92	-1.6
802.11n 40MHz Port R21	Low	5755	-10.82	-8.98	-1.59
	High	5795	-10.43	-8.21	-0.87
802.11n 40 MHz Port R22	Low	5755	-11.17	-8.49	-0.82
	High	5795	-11.18	-8.91	-0.83

**Table 13. Power Spectral Density, 40 MHz**

\*Note: According to 15.247 KDB, measurement RBW is **100 KHz** while Limit is 30dBm/**500KHz**. So limits should be divided by 5 to be compared with 100 KHz RBW measurement

Summed PSD					
	Channel	Frequency (MHz)	Measured PSD (dBm)		
Gain			19dBi	16dBi	9dBi
802.11n 20 MHz Summed	Low	5755	-5.53	-2.96	4.49
	High	5795	-4.66	-2.56	4.68
Limit			17	20	27

**Table 14. Power Spectral Density, 40 MHz, Summed Power Spectral Density**

## Electromagnetic Compatibility Criteria for Intentional Radiators

### §15.407(b)(4) & (6 – 7) Undesirable Emissions

**Test Requirements:** § 15.407(b)(4): For transmitters operating in the 5.725-5.85 GHz band: All emissions within the frequency range from the band edge to 10 MHz above or below the band edge shall not exceed an e.i.r.p. of -17 dBm/MHz; for frequencies 10 MHz or greater above or below the band edge, emissions shall not exceed an e.i.r.p. of -27 dBm/MHz.

§ 15.407(b)(6): Unwanted emissions below 1 GHz must comply with the general field strength limits set forth in Section 15.209. Further, any U-NII devices using an AC power line are required to comply also with the conducted limits set forth in Section 15.207.

§ 15.407(b)(7): The provisions of Section 15.205 of this part apply to intentional radiators operating under this section.

**Test Procedure:** The EUT was placed on a non-conducting stand on a turntable in a chamber. To find the maximum emission the EUT was set to transmit on low, mid, and high channels. Additionally, the turntable was rotated 360 degrees, the EUT was oriented through its three orthogonal axes, and the receive antenna height was varied in order to maximize emissions.

For frequencies from 30 MHz to 1 GHz, measurements were first made using a peak detector with a 100 kHz resolution bandwidth. Emissions which exceeded the limits were re-measured using a quasi-peak detector with a 120 kHz resolution bandwidth.

Above 1 GHz, measurements were made pursuant the method described in FCC KDB 789033 D02 General UNII Test Procedure New Rules v01. The equation,  $EIRP = E + 20 \log D - 104.8$  was used to convert field strength to EIRP ( $E$  = field strength (dB $\mu$ V/m) and  $D$  = Reference measurement distance).

Above 1 GHz, a notch filter (5725MHz – 5850MHz) are used for filter the fundamental signal.

For emissions above 1 GHz and in restricted bands, measurements of the field strength were made with a peak detector and an average detector and compared with the limits of 15.209.

As an alternative, according to FCC KDB 789033 D02 General UNII Test Procedure New Rules v01, all emissions above 1 GHz that comply with the peak and average limits of 15.209 satisfy the requirements of unwanted emissions in 15.407.

**Test Results:** For below 1 GHz, the EUT was compliant with the requirements of this section. The EUT was compliant with the Radiated Spurious Emission limits of § 15.407(b). The over-the-limit emissions in the range 30 MHz to 1000 MHz appear to be digital emissions since they still exist when the radio is off.

For above 1 GHz, the EUT was compliant with the requirements of this section.

Only noise floor was observed above 18GHz.

Measured emissions were within applicable limits.

**Test Engineer(s):** Jun Qi

**Test Date(s):** November 30, 2016

**Undesirable Emissions, Below 1 GHz**

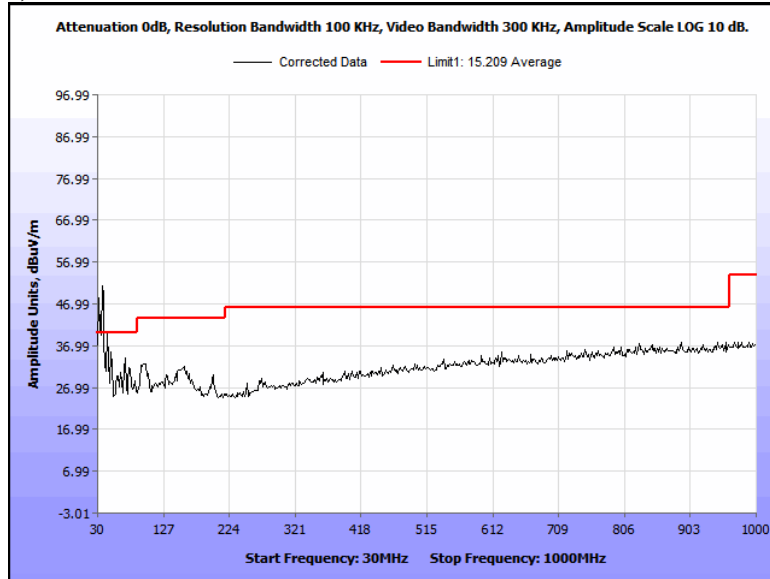

**Plot 1. Radiated Spurious Emissions, 11n, 40 MHz, Low , 5755 MHz, Average 9 dBi**

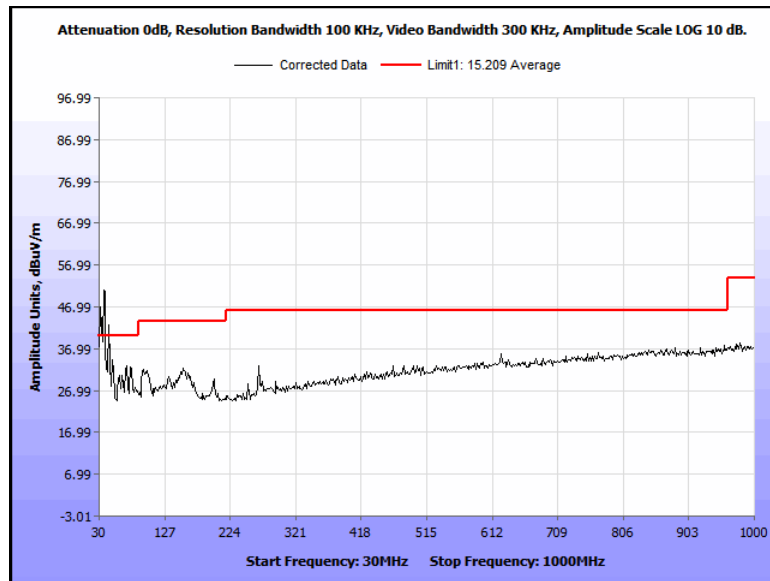

**Plot 2. Radiated Spurious Emissions, 11n, 40 MHz, High, 5795 MHz, Average 9 dBi**

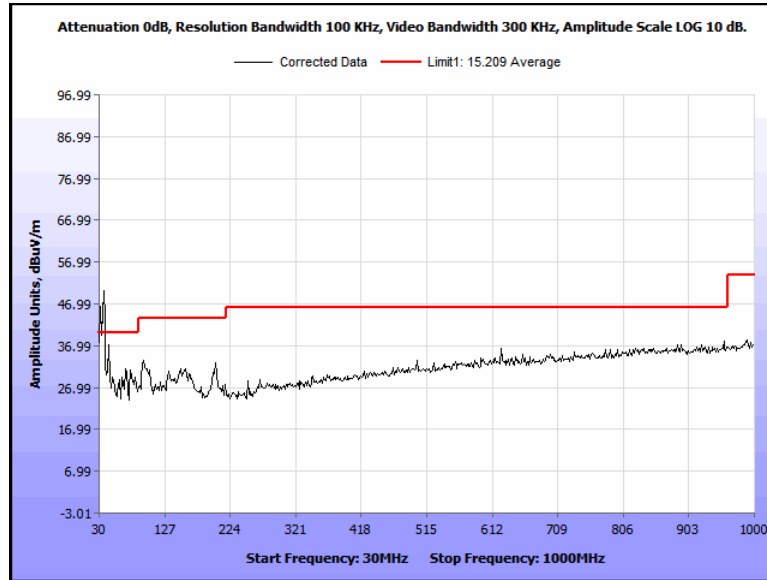

**Plot 3. Radiated Spurious Emissions, 11n, 40 MHz, Low, 5755 MHz, Average 16 dBi**

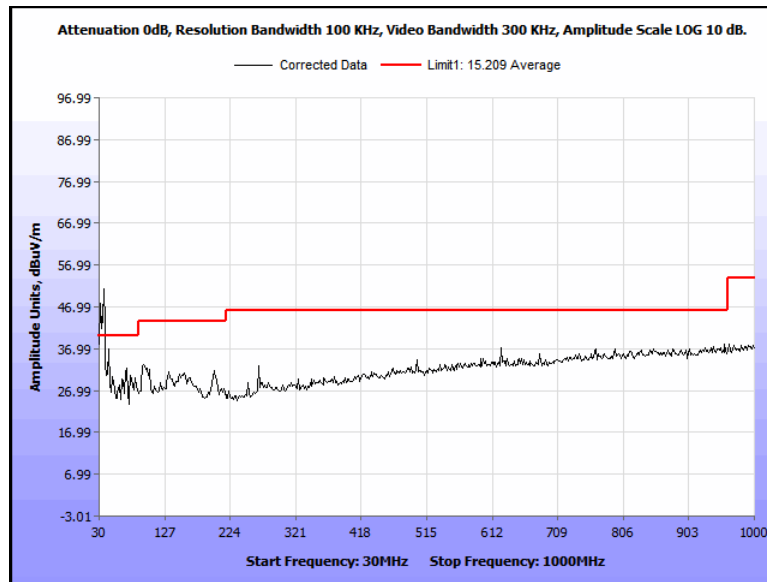

**Plot 4. Radiated Spurious Emissions, 11n, 40 MHz, High, 5795 MHz, Average 16 dBi**

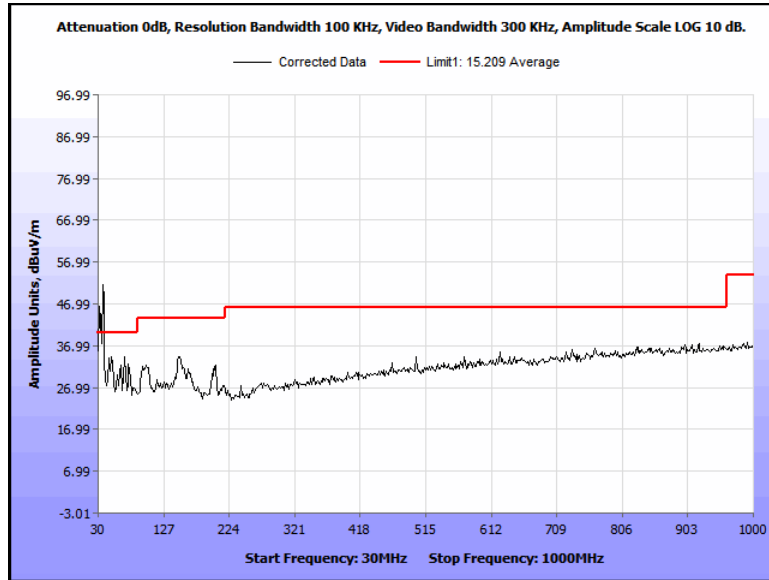

**Plot 5. Radiated Spurious Emissions, 11n, 40 MHz, Low, 5755 MHz, Average 19 dBi**

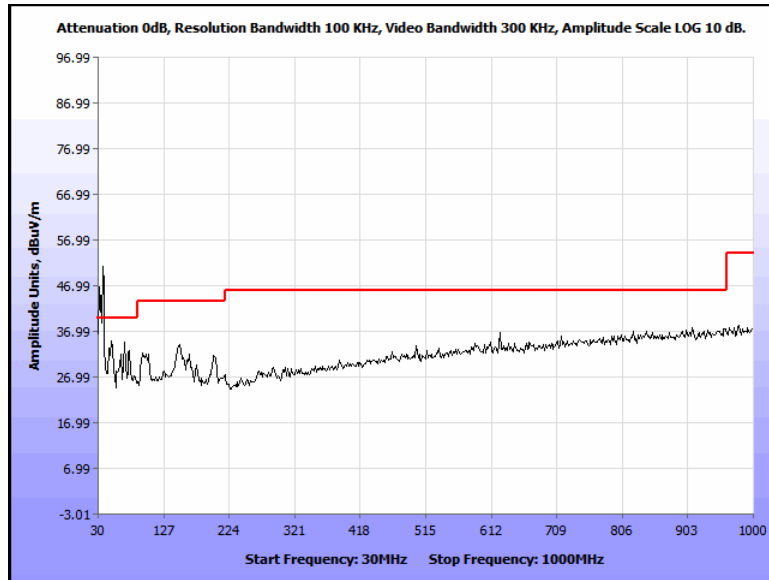

**Plot 6. Radiated Spurious Emissions, 11n, 40 MHz, Low, 5795 MHz, Average 19 dBi**

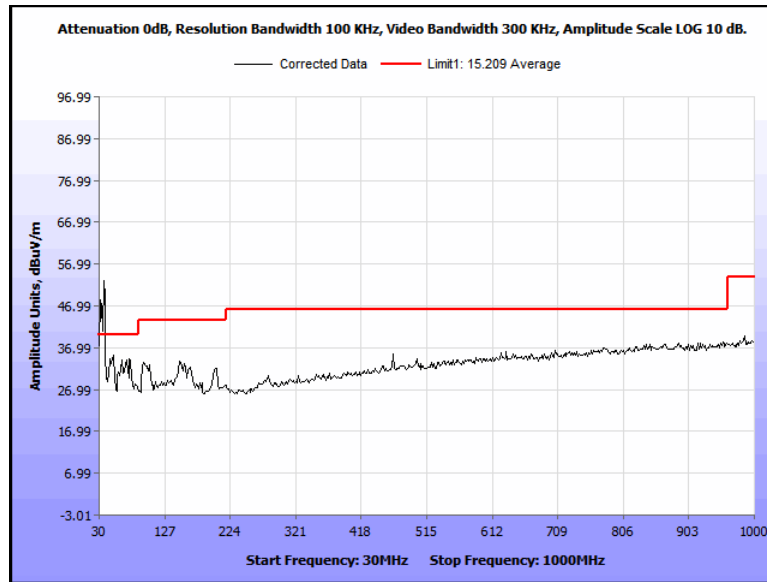

**Plot 7. Radiated Spurious Emissions, No radiate, Power on only**

**Undesirable Emissions, Above 1 GHz**

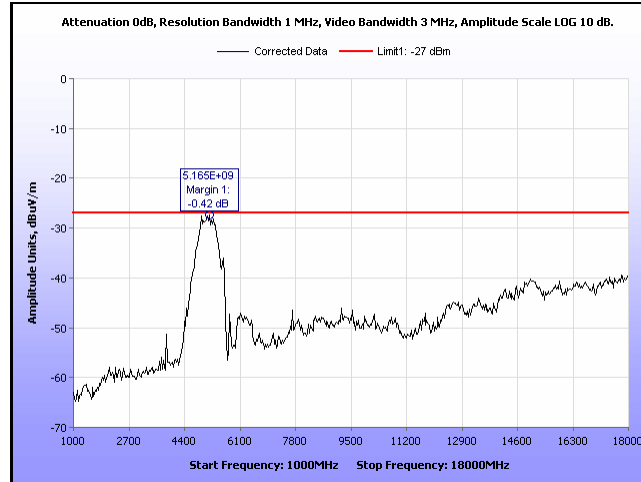

**Plot 8. Radio Spurious Emission, 1 GHz - 18 GHz - 27 dBm, Bandwidth 40M, Ch. 5795M, n mode, 9 dBi**

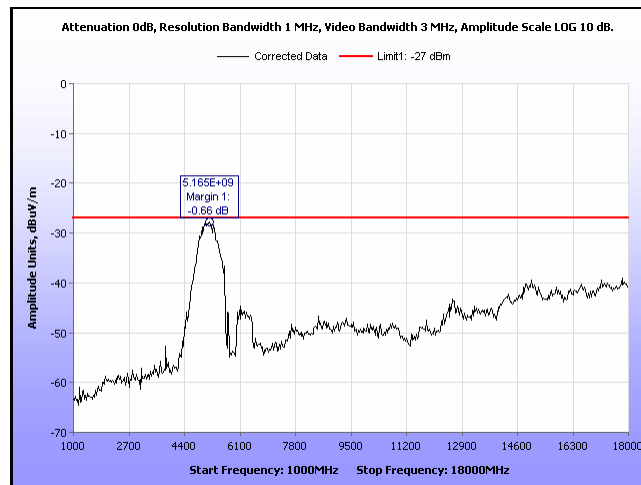

**Plot 9. Radio Spurious Emission, 1 GHz - 18 GHz - 27 dBm, Bandwidth 40M, Ch. 5755M, n mode, 9dBi**

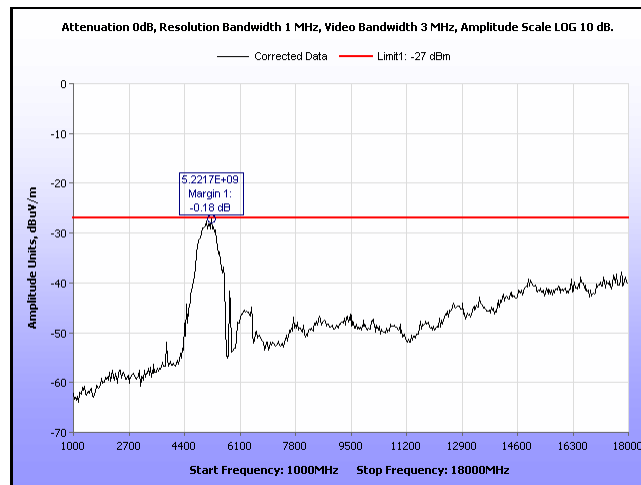

**Plot 10. Radio Spurious Emission, 1 GHz - 18 GHz - 27 dBm, Bandwidth 20M, Ch. 5805M, n mode, 9 dBi**



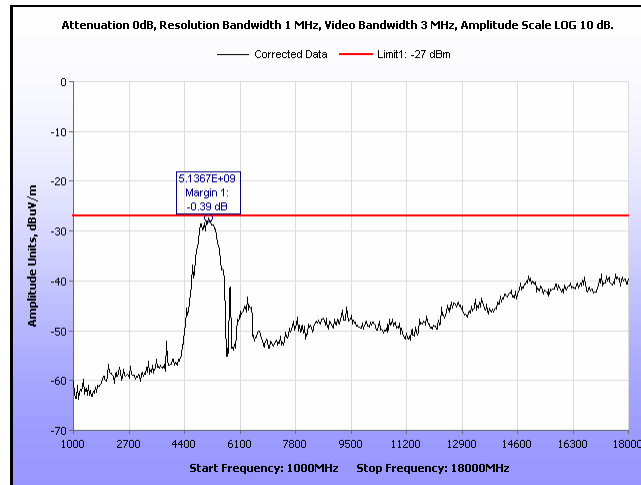

**Plot 11. Radio Spurious Emission, 1 GHz - 18 GHz - 27 dBm, Bandwidth 20M, Ch. 5805M, a mode, 9 dBi**

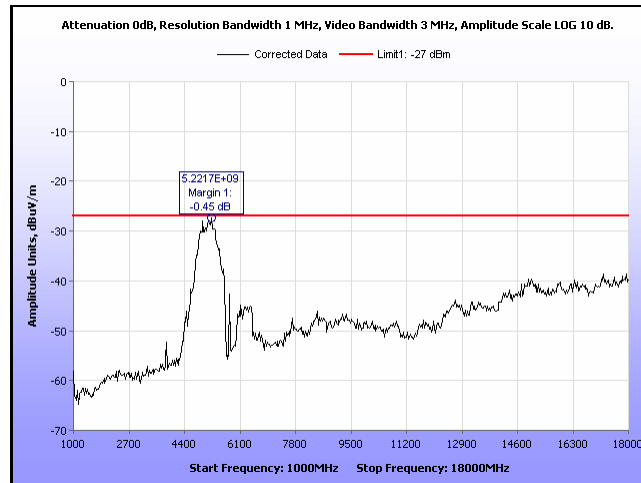

**Plot 12. Radio Spurious Emission, 1 GHz - 18 GHz - 27 dBm, Bandwidth 20M, Ch. 5785M, n mode, 9 dBi**

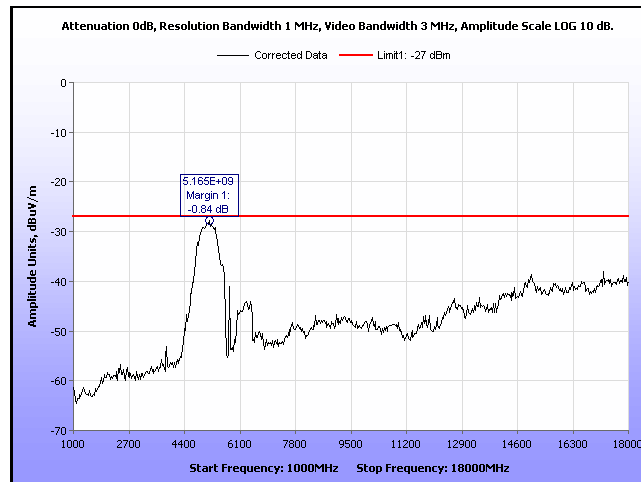

**Plot 13. Radio Spurious Emission, 1 GHz - 18 GHz - 27 dBm, Bandwidth 20M, Ch. 5785M, a mode, 9 dBi**

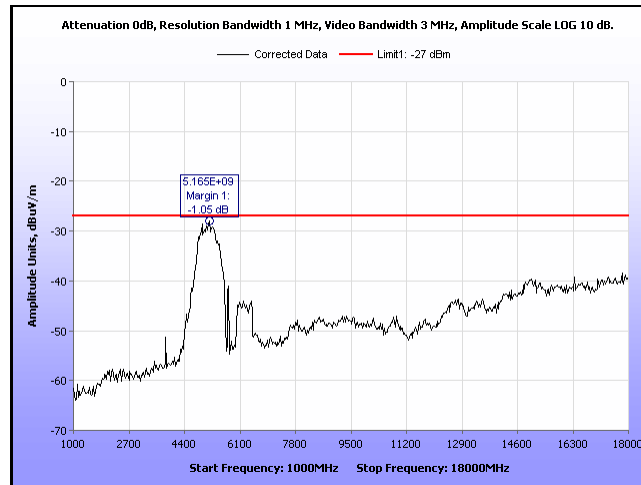

**Plot 14. Radio Spurious Emission, 1 GHz - 18 GHz - 27 dBm, Bandwidth 20M, Ch. 5745M, a mode, 9 dBi**

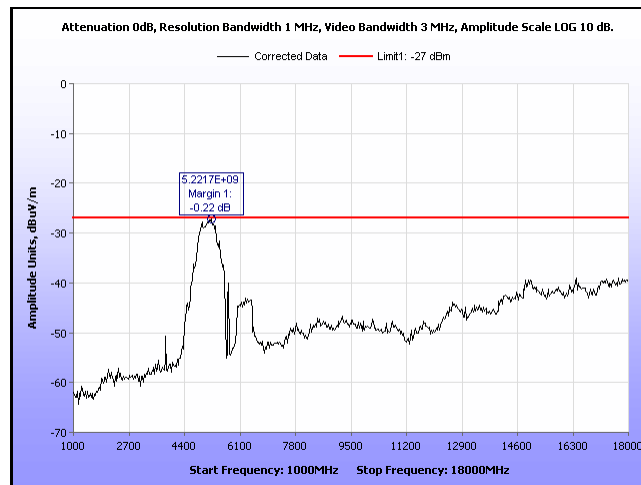

**Plot 15. Radio Spurious Emission, 1 GHz - 18 GHz - 27 dBm, Bandwidth 20M, Ch. 5745M, a mode, 9 dBi**

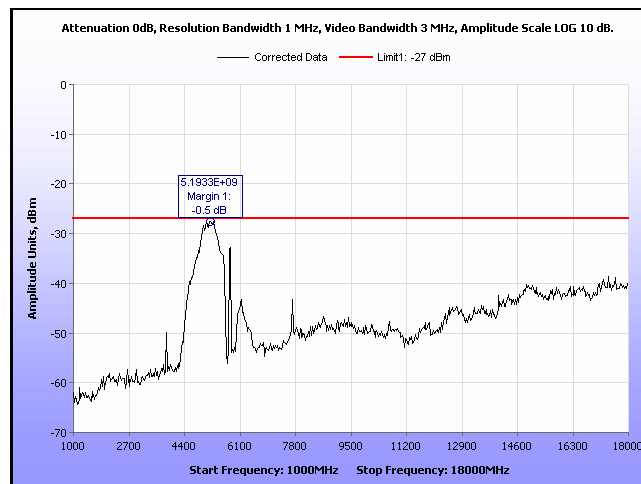

**Plot 16. Radio Spurious Emission, 1 GHz - 18 GHz - 27 dBm, Bandwidth 40M, Ch. 5795M, n mode, 16 dBi**

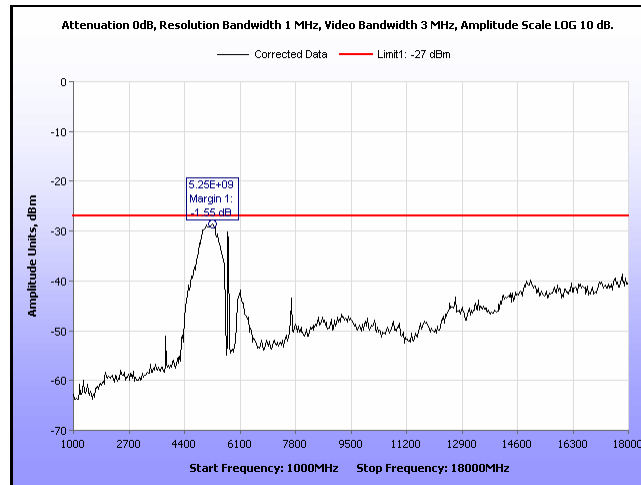

**Plot 17. Radio Spurious Emission, 1 GHz - 18 GHz - 27 dBm, Bandwidth 40M, Ch. 5755M, n mode, 16 dBi**

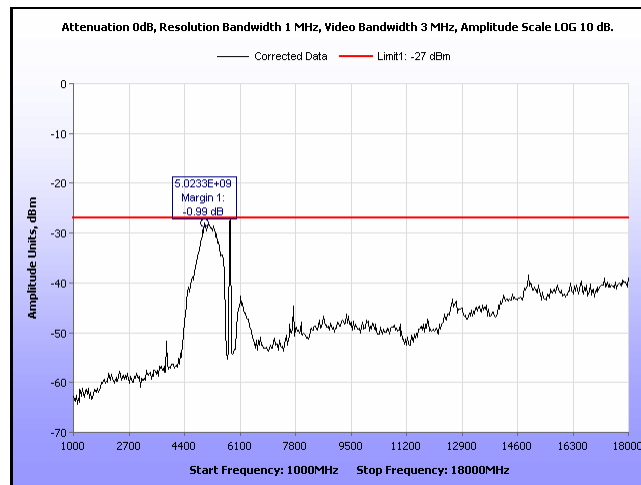

**Plot 18. Radio Spurious Emission, 1 GHz - 18 GHz - 27 dBm, Bandwidth 20M, Ch. 5805M, n mode, 16 dBi**

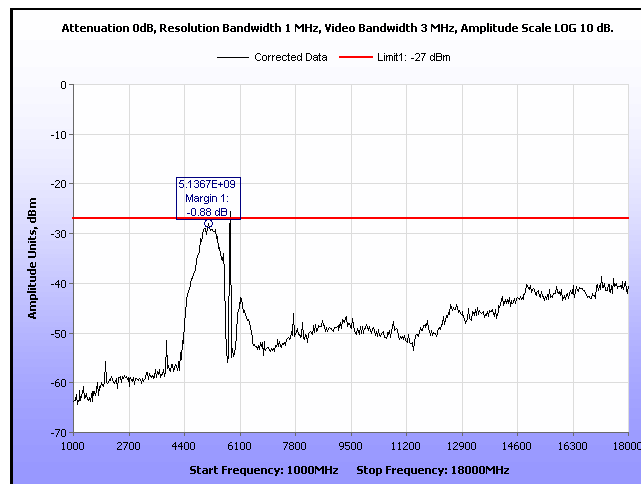

**Plot 19. Radio Spurious Emission, 1 GHz - 18 GHz - 27 dBm, Bandwidth 20M, Ch. 5805M, a mode, 16 dBi**

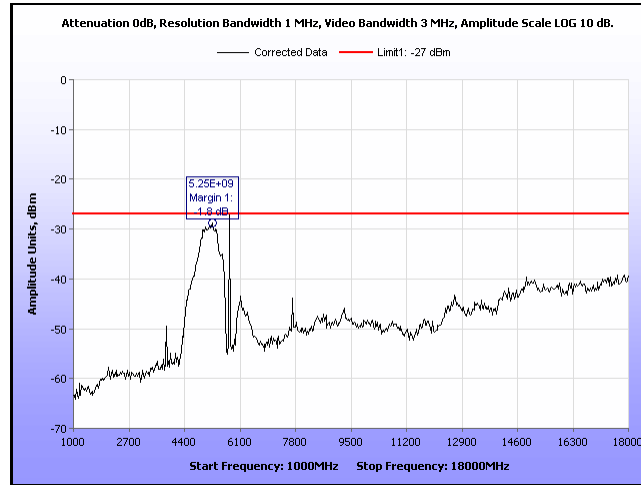

**Plot 20. Radio Spurious Emission, 1 GHz - 18 GHz - 27 dBm, Bandwidth 20M, Ch. 5785M, n mode, 16 dBi**

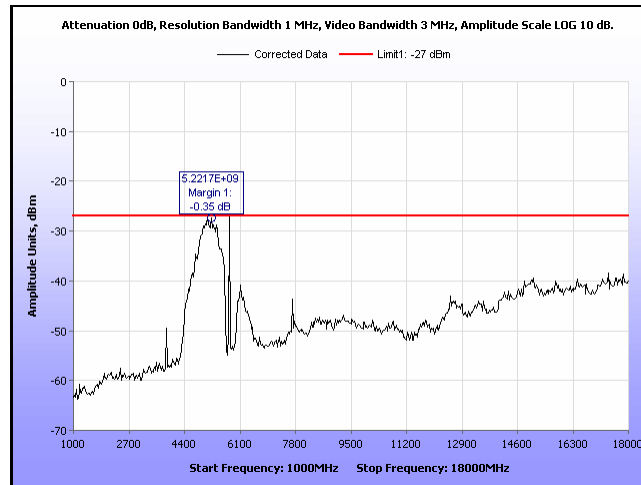

**Plot 21. Radio Spurious Emission, 1 GHz - 18 GHz - 27 dBm, Bandwidth 20M, Ch. 5785M, a mode, 16 dBi**

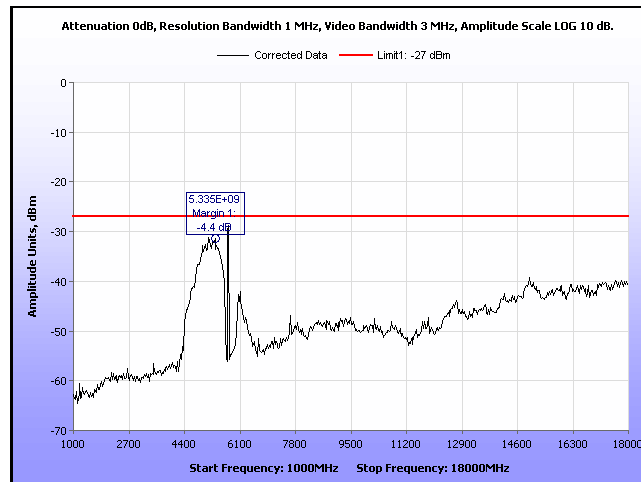

**Plot 22. Radio Spurious Emission, 1 GHz - 18 GHz - 27 dBm, Bandwidth 20M, Ch. 5745M, n mode, 16 dBi**

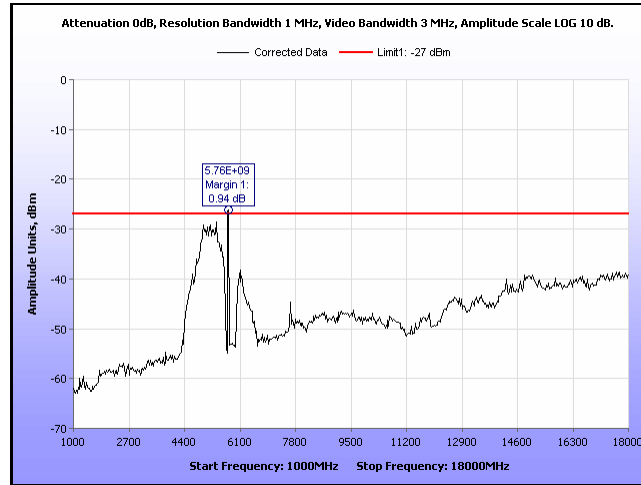

**Plot 23. Radio Spurious Emission, 1 GHz - 18 GHz - 27 dBm, Bandwidth 20M, Ch. 5745M, a mode, 16 dBi**

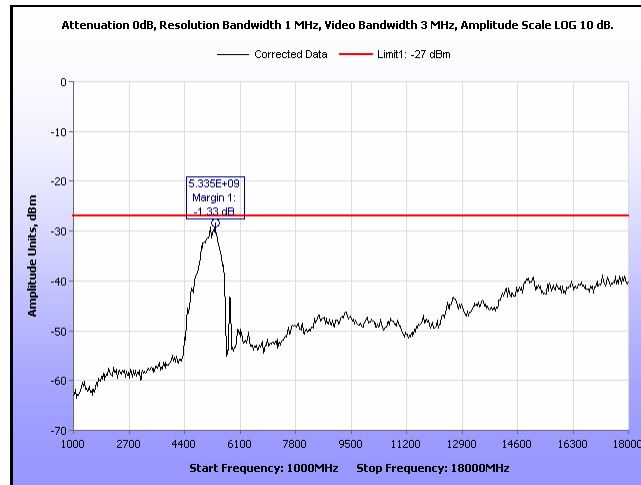

**Plot 24. Radio Spurious Emission, 1 GHz - 18 GHz - 27dBm, Bandwidth 40M, Ch. 5795M, n mode, 19 dBi**

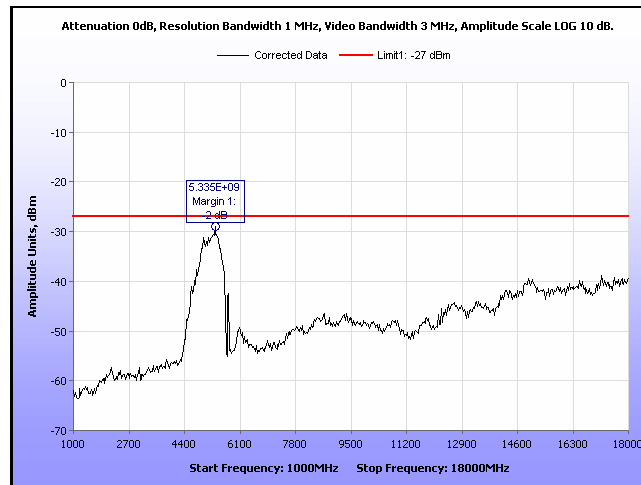

**Plot 25. Radio Spurious Emission, 1 GHz - 18 GHz - 27dBm, Bandwidth 40M, Ch. 5755M, n mode, 19 dBi**

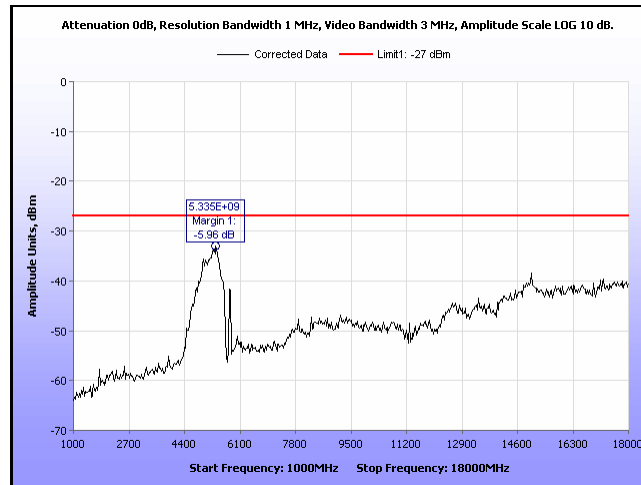

**Plot 26. Radio Spurious Emission, 1 GHz - 18 GHz -27 dBm, Bandwidth 20M, Ch.5805M, n mode, 19 dBm**

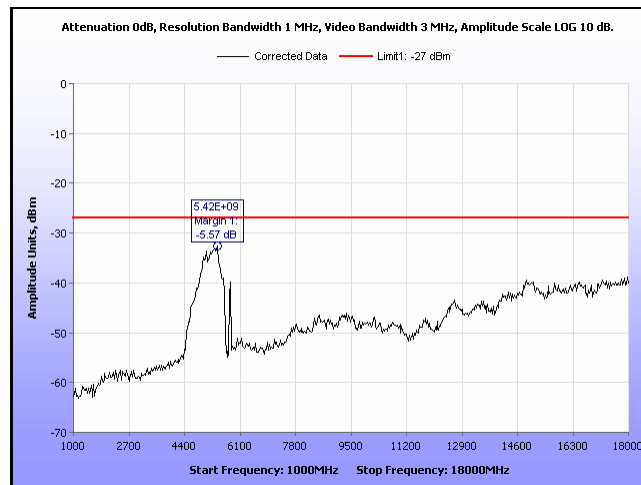

**Plot 27. Radio Spurious Emission, 1 GHz - 18 GHz -27 dBm, Bandwidth 20M, Ch. 5805M, a mode, 19 dBm**

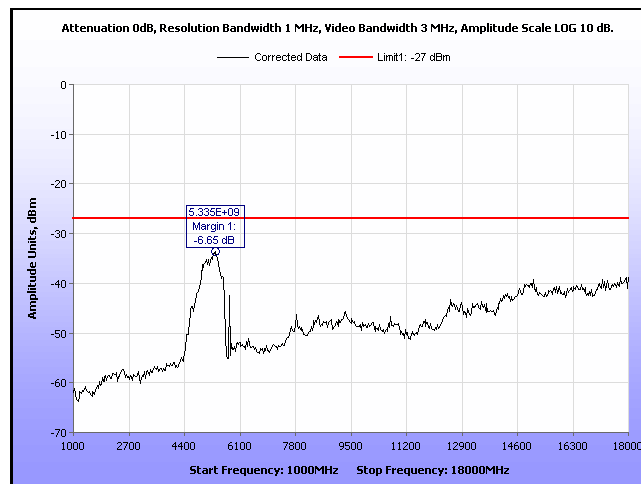

**Plot 28. Radio Spurious Emission, 1 GHz - 18 GHz -27 dBm, Bandwidth 20M, Ch. 5785M, n mode, 19 dBm**

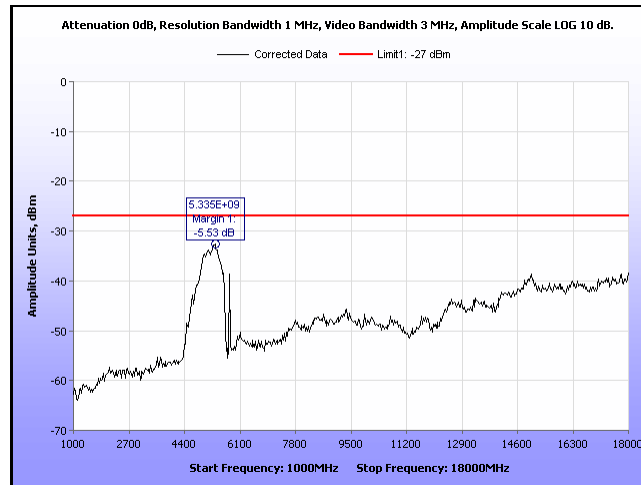

**Plot 29. Radio Spurious Emission, 1 GHz - 18 GHz -27 dBm, Bandwidth 20M, Ch. 5785M, a mode, 19 dB**

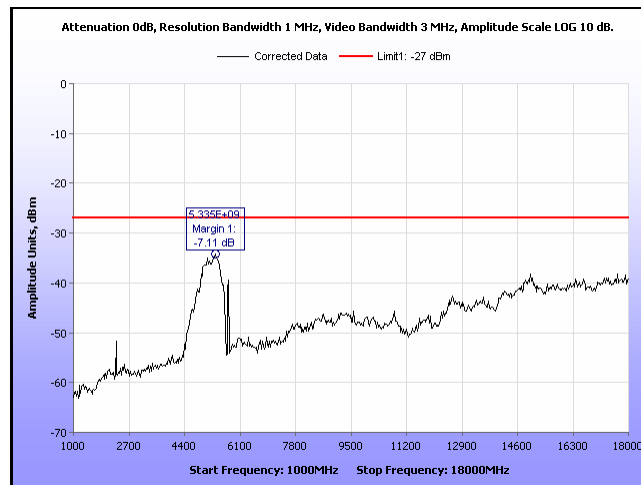

**Plot 30. Radio Spurious Emission, 1 GHz - 18 GHz -27 dBm, Bandwidth 20M, Ch. 5745M, n mode, 19 dB**

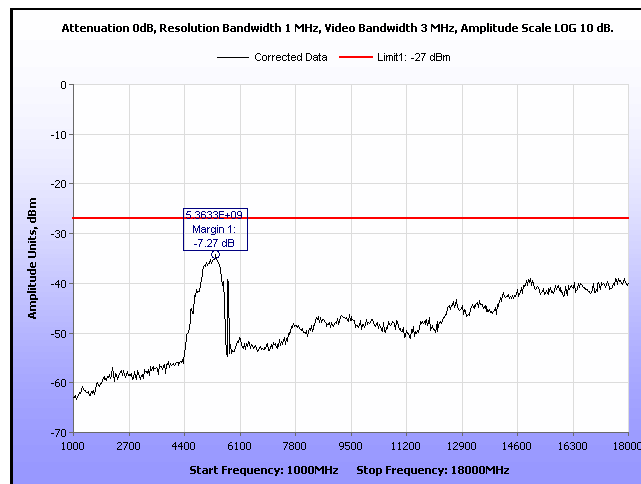

**Plot 31. Radio Spurious Emission, 1 GHz - 18 GHz -27 dBm, Bandwidth 20M, Ch. 5745M, a mode, 19 dB**

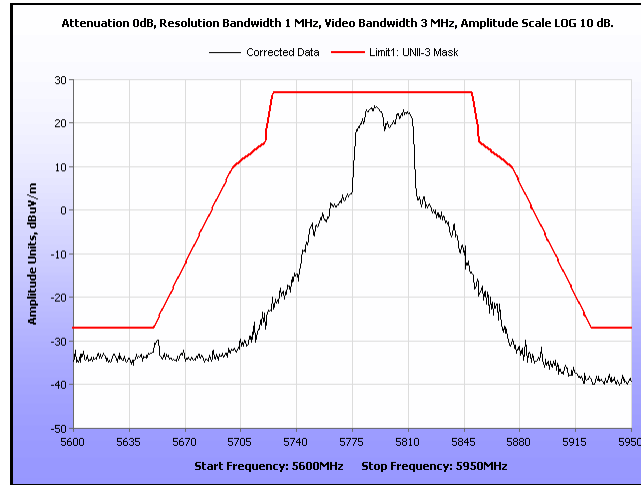

**Plot 32. UNII-3 Mask, 11n, 40MHz, 5795M, 9 dBi**

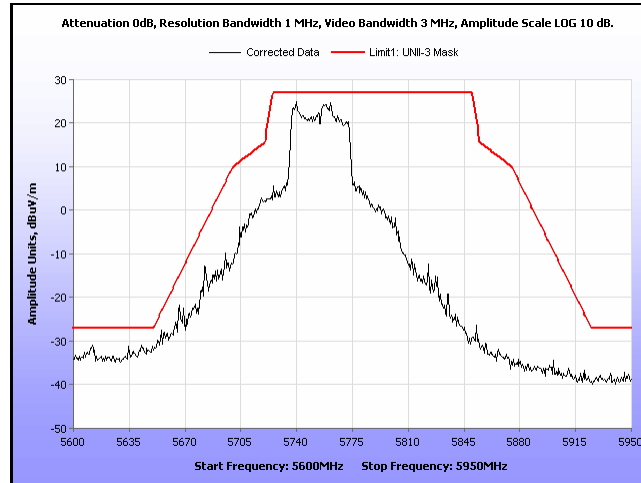

**Plot 33. UNII-3 Mask, 11n, 40MHz, 5755MHz, 9 dBi**

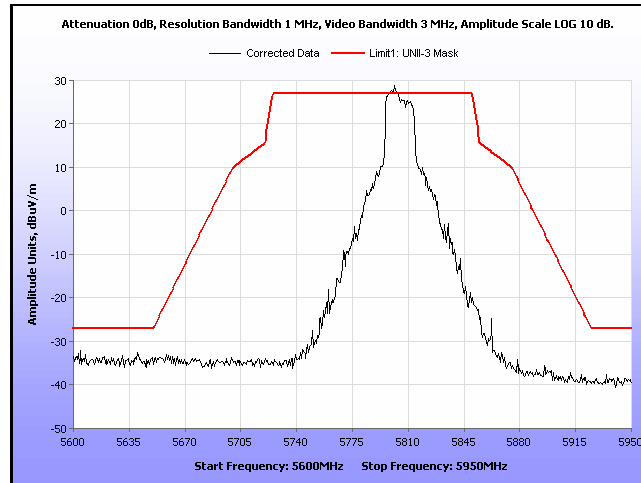

**Plot 34. UNII-3 Mask, 11n, 20MHz, 5805M, 9 dBi**



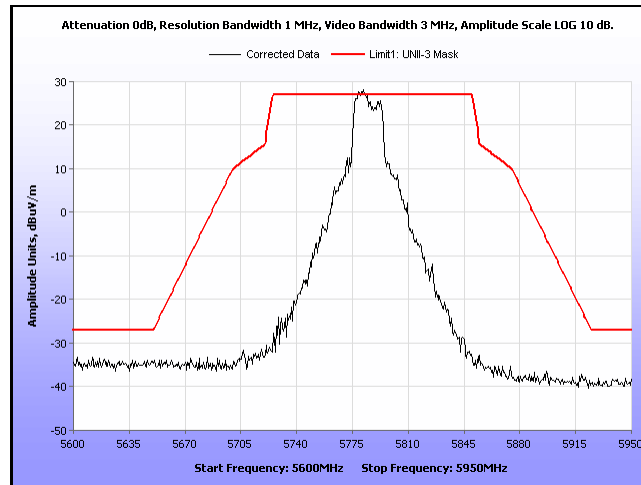

**Plot 35. UNII-3 Mask, 11n, 20MHz, 5785MHz, 9 dBi**

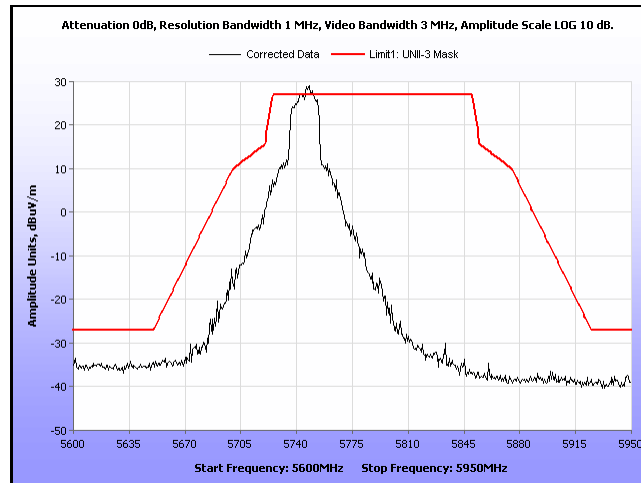

**Plot 36. UNII-3 Mask, 11n, 20MHz, 5745MHz, 9 dBi**

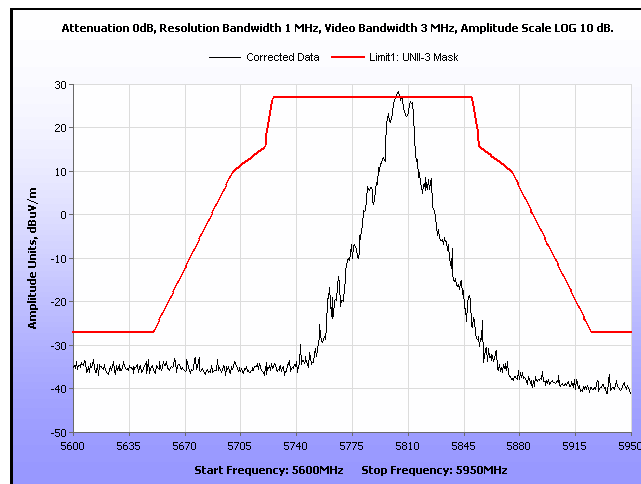

**Plot 37. UNII-3 Mask, 11a, 20MHz, 5805MHz, 9 dBi**

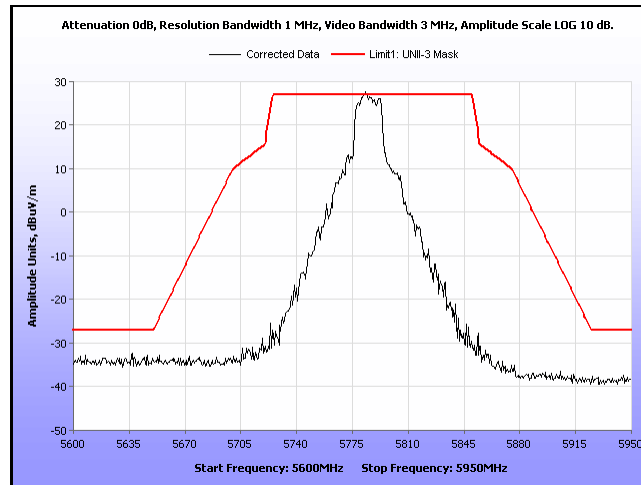

**Plot 38. UNII-3 Mask, 11a, 20MHz, 5785 MHz, 9 dBi**

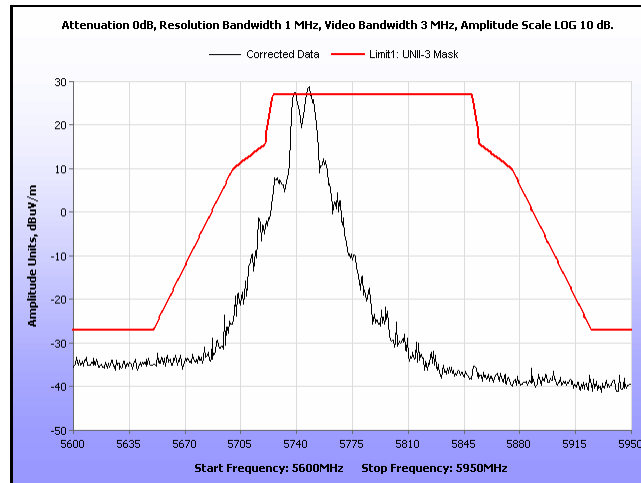

**Plot 39. UNII-3 Mask, 11a, 20MHz, 5745 MHz, 9 dBi**

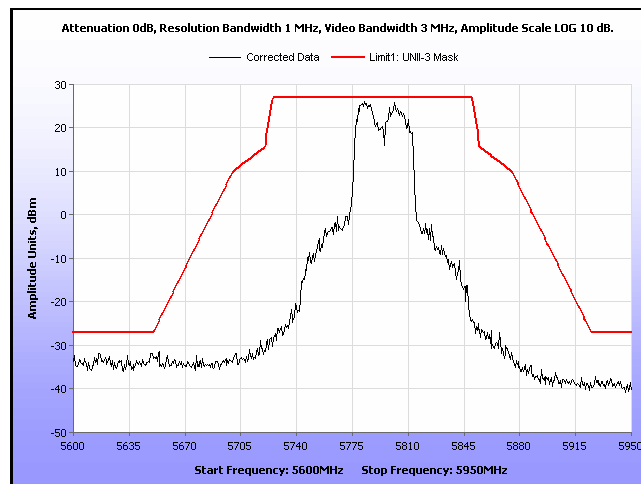

**Plot 40. UNII-3 Mask, 11n, 40 MHz, 5795 MHz, 16 dBi**

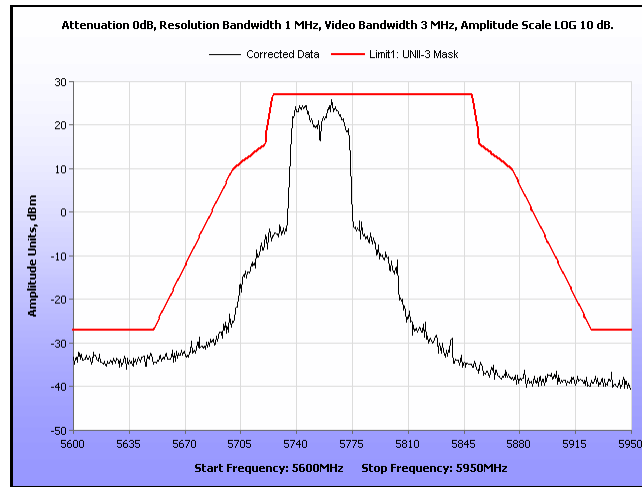

**Plot 41. UNII-3 Mask, 11n, 40 MHz, 5755 MHz, 16 dBi**

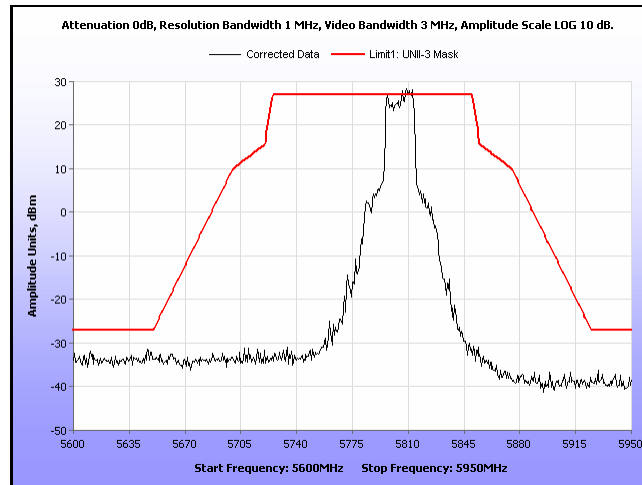

**Plot 42. UNII-3 Mask, 11n, 20 MHz, 5805 MHz, 16 dBi**

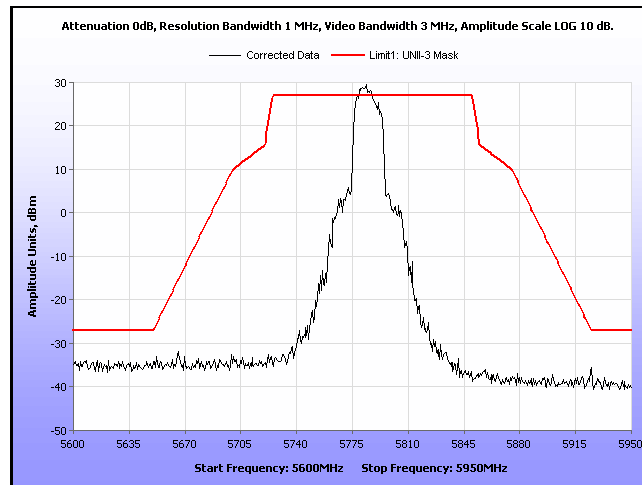

**Plot 43. UNII-3 Mask, 11n, 20 MHz, 5785 MHz, 16 dBi**

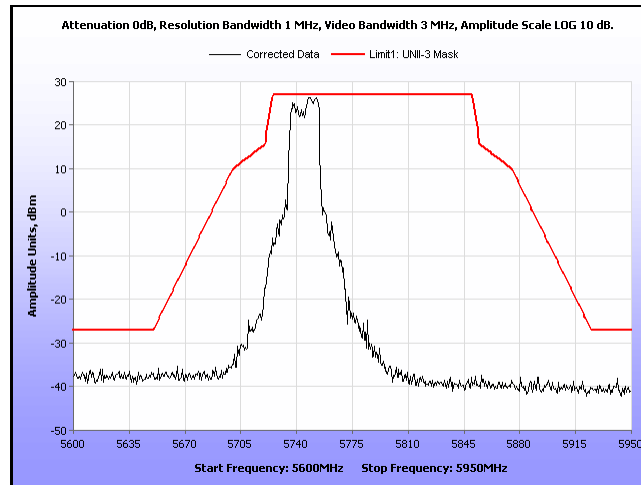

**Plot 44. UNII-3 Mask, 11n, 20 MHz, 5745 MHz, 16 dBi**

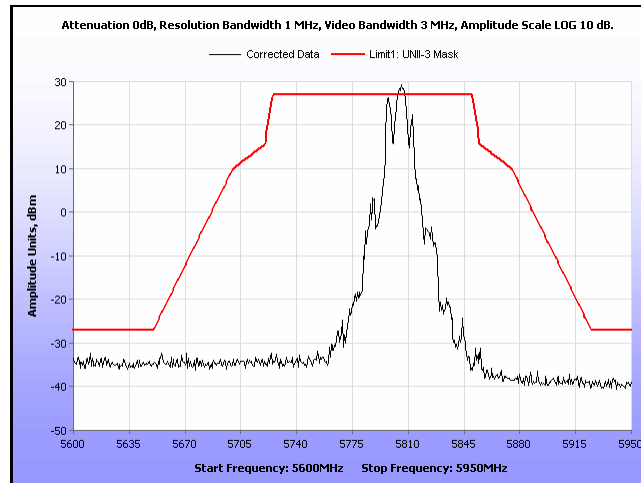

**Plot 45. UNII-3 Mask, 11a, 20 MHz, 5805 MHz, 16 dBi**

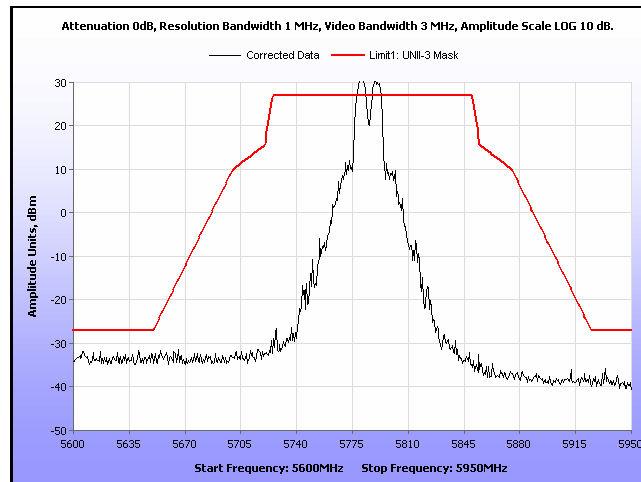

**Plot 46. UNII-3 Mask, 11a, 20 MHz, 5785 MHz, 16 dBi**

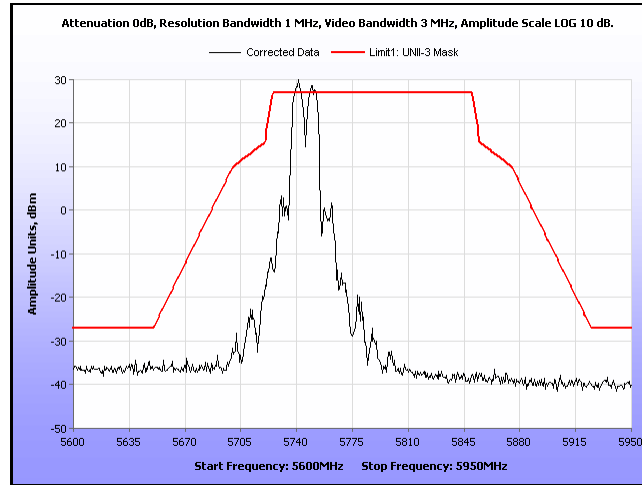

**Plot 47. UNII-3 Mask, 11a, 20 MHz, 5745 MHz, 16 dB**

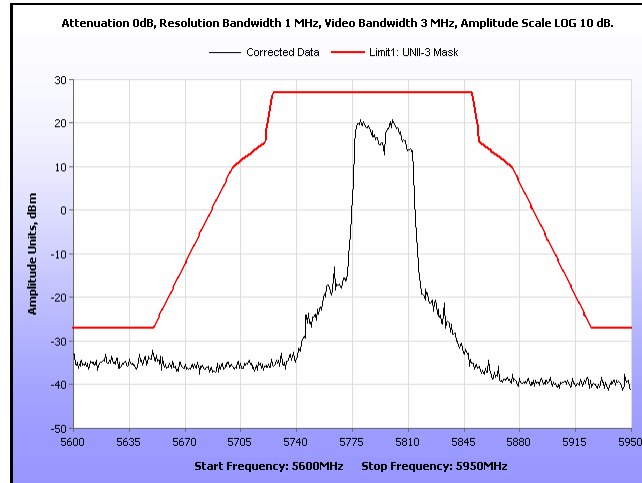

**Plot 48. UNII-3 Mask, 11n, 40 MHz, 5795 MHz, 19 dB**

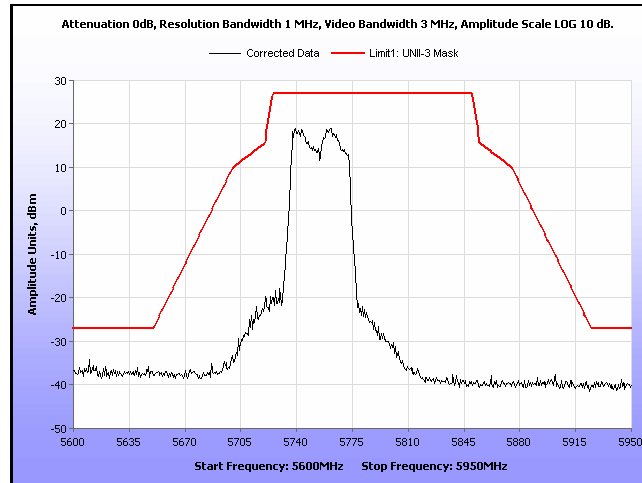

**Plot 49. UNII-3 Mask, 11n, 40 MHz, 5755 MHz, 19 dB**

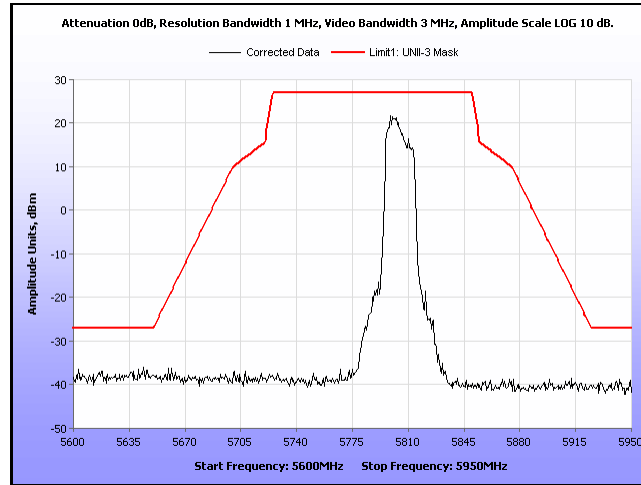

**Plot 50. UNII-3 Mask, 11n, 20 MHz, 5805 MHz, 19 dBi**

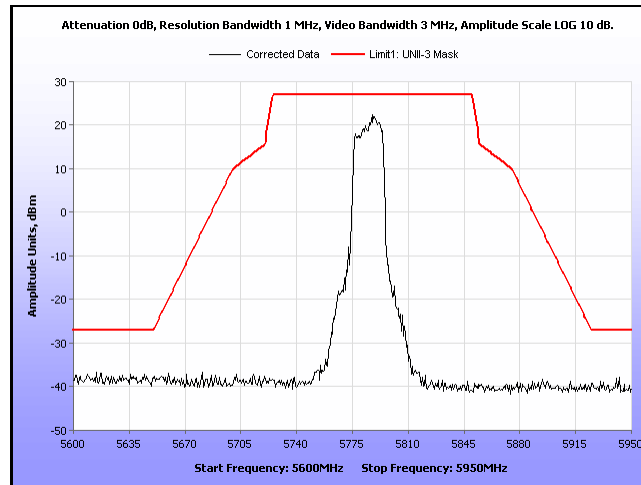

**Plot 51. UNII-3 Mask, 11n, 20 MHz, 5785 MHz, 19 dBi**

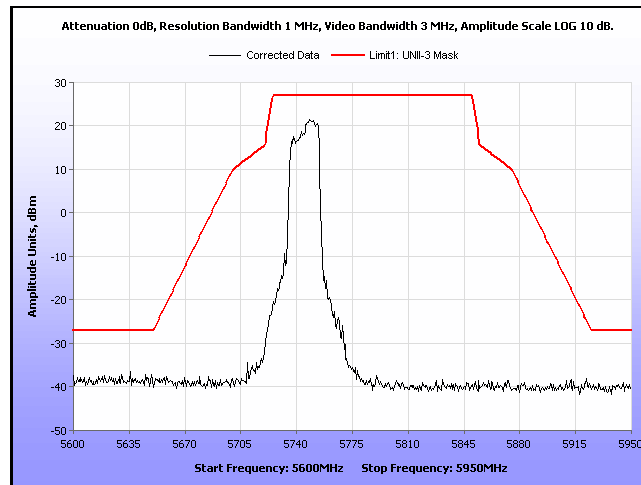

**Plot 52. UNII-3 Mask, 11n, 20 MHz, 5745 MHz, 19 dBi**

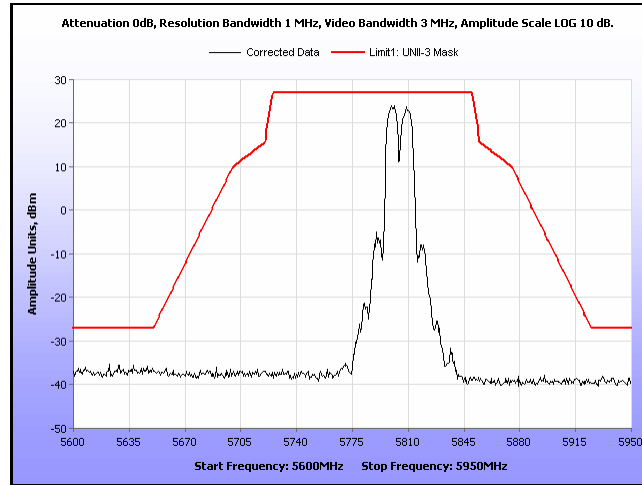

**Plot 53. UNII-3 Mask, 11a, 20 MHz, 5805 MHz, 19 dBi**

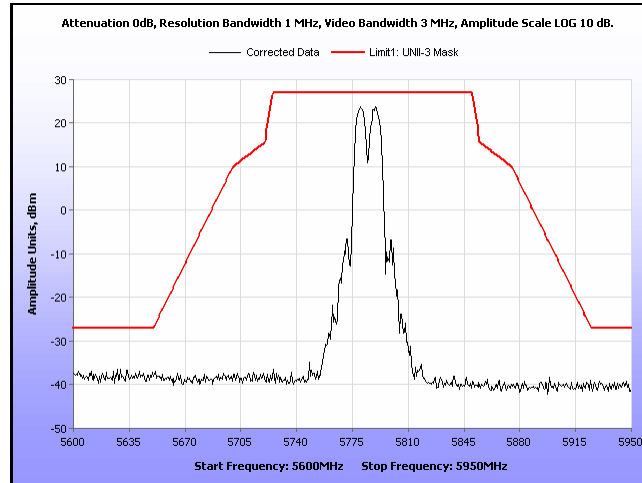

**Plot 54. UNII-3 Mask, 11a, 20 MHz, 5785 MHz, 19 dBi**

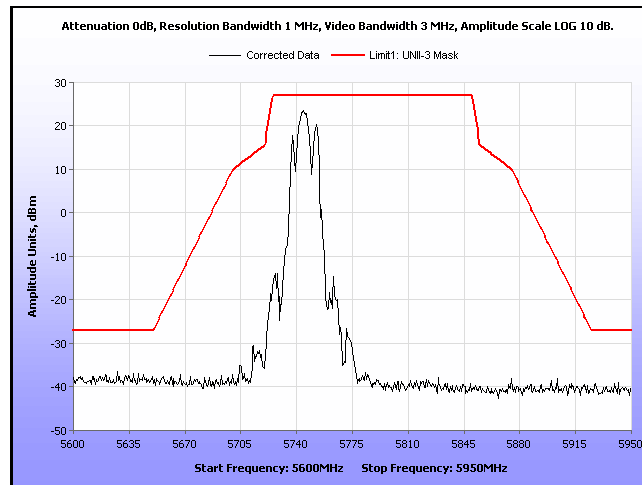

**Plot 55. UNII-3 Mask, 11a, 20 MHz, 5745 MHz, 19 dBi**

## Electromagnetic Compatibility Criteria for Intentional Radiators

### § 15.407(b)(6) Conducted Emissions

**Test Requirement(s):** § 15.407 (b)(6): Any U-NII devices using an AC power line are required to comply also with the conducted limits set forth in §15.207.

§ 15.207 (a): For an intentional radiator that is designed to be connected to the public utility (AC) power line, the radio frequency voltage that is conducted back onto the AC power line on any frequency or frequencies, within the band 150 kHz to 30MHz, shall not exceed the limits in the following table, as measured using a 50  $\mu$ H/50  $\Sigma$  line impedance stabilization network (LISN). Compliance with the provisions of this paragraph shall be based on the measurement of the radio frequency voltage between each power line and ground at the power terminal. The lower limit applies at the boundary between the frequency ranges.

Frequency range (MHz)	§ 15.207(a), Conducted Limit (dB $\mu$ V)	
	Quasi-Peak	Average
* 0.15- 0.45	66 – 56	56 - 46
0.45 - 0.5	56	46
0.5 - 30	60	50

**Table 15. Conducted Limits for Intentional Radiators from FCC Part 15 § 15.207(a)**

**Test Procedure:** The EUT was placed on a non-metallic table inside a screen room. The EUT was situated such that the back of the EUT was 0.4 m from one wall of the vertical ground plane, and the remaining sides of the EUT were no closer than 0.8 m from any other conductive surface. The EUT was powered from a 50  $\Omega$ /50  $\mu$ H Line Impedance Stabilization Network (LISN). The EMC receiver scanned the frequency range from 150 kHz to 30 MHz. Conducted Emissions measurements were made in accordance with ANSI C63.4-2014 "Methods and Measurements of Radio-Noise Emissions from Low-Voltage Electrical and Electronic Equipment in the Range of 9kHz to 40 GHz". Scans were performed with the transmitter on.

**Test Results:** The EUT was compliant with requirements of this section. Measured emissions were within applicable limits.

**Test Engineer(s):** Jun Qi

**Test Date(s):** June 21, 2016



Line	Freq (MHz)	QP Amplitude	QP Limit	Delta	Pass	Average Amplitude	Average Limit	Delta	Pass
Line1	0.4956	37.23	56.076	-18.846	Pass	25.6	46.076	-20.476	Pass
Line1	4.5590	30.44	56	-25.56	Pass	22.46	46	-23.54	Pass
Line1	10.6204	31.66	60	-28.34	Pass	23.93	50	-26.07	Pass
Line1	11.7533	32.92	60	-27.08	Pass	25.39	50	-24.61	Pass
Line1	13.1868	32.7	60	-27.3	Pass	25.33	50	-24.67	Pass
Line1	18.5652	31.84	60	-28.16	Pass	25.55	50	-24.45	Pass

Table 16. Conducted Emissions, 15.407(b)(6), Line 1, Test Results

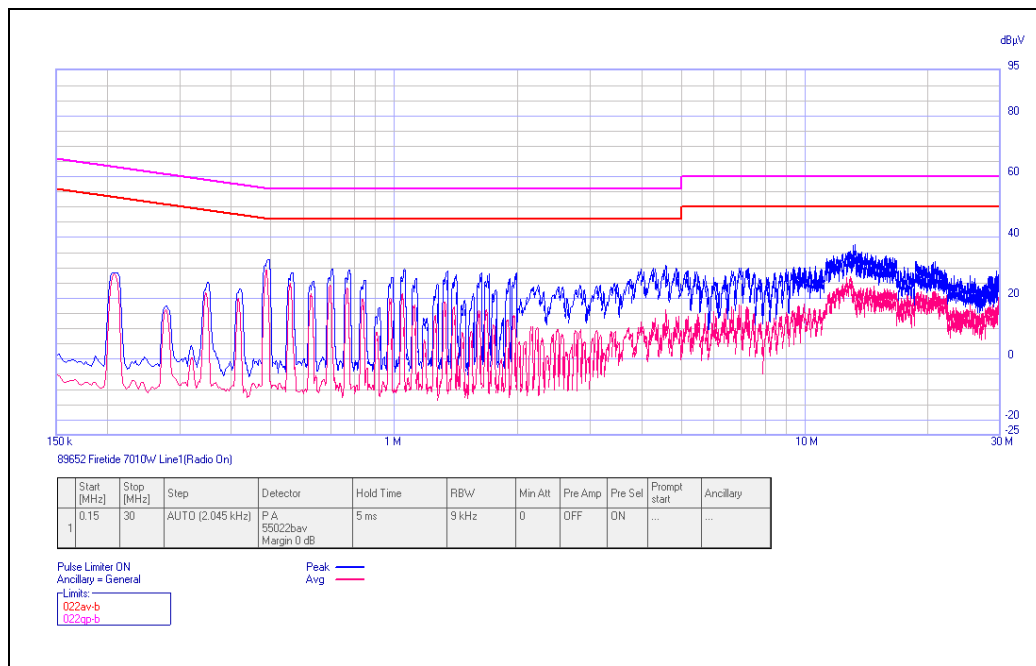

Plot 56. Conducted Emissions, Line 1 (Radio On)

Line	Freq (MHz)	QP Amplitude	QP Limit	Delta	Pass	Average Amplitude	Average Limit	Delta	Pass
Neutral	0.1909	47.97	64.003	-16.033	Pass	29.99	54.003	-24.013	Pass
Neutral	0.25225	37.27	61.695	-24.425	Pass	22.76	51.695	-28.935	Pass
Neutral	0.45266	36.84	56.85	-20.01	Pass	24.38	46.85	-22.47	Pass
Neutral	12.0928	32.27	60	-27.73	Pass	25.17	50	-24.83	Pass
Neutral	13.0253	32.85	60	-27.15	Pass	25.28	50	-24.72	Pass
Neutral	17.5222	32.45	60	-27.55	Pass	25.91	50	-24.09	Pass

**Table 17. Conducted Emissions, 15.407(b)(6), Neutral, Test Results**

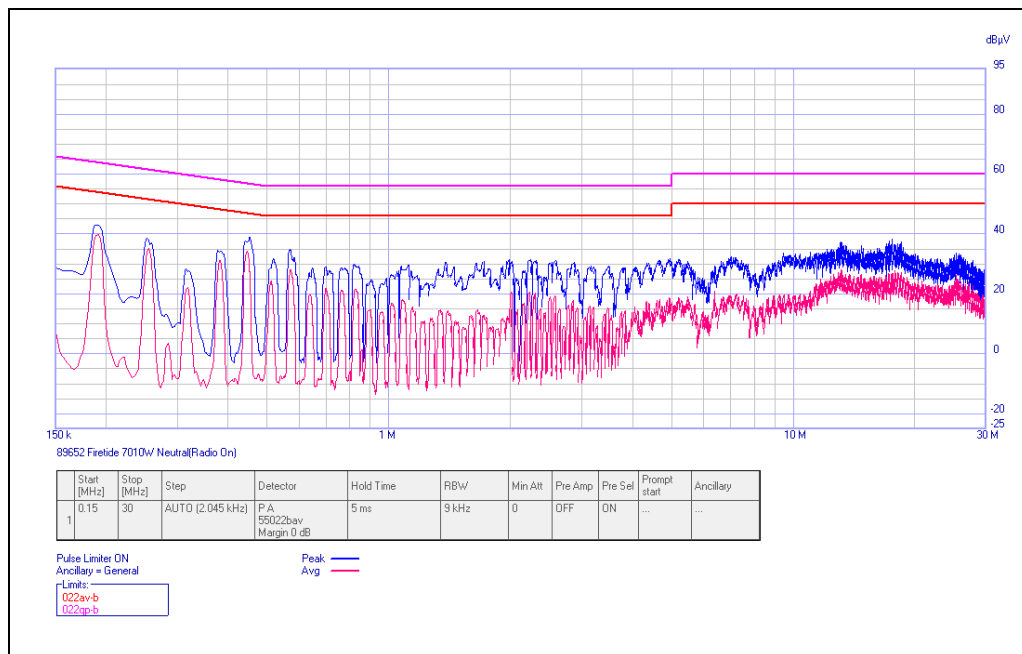

**Plot 57. Conducted Emissions, Neutral Line (Radio On)**

## Electromagnetic Compatibility Criteria for Intentional Radiators

### § 15.407(c) Automatic Discontinue of Transmission

**Test Requirement(s):** § 15.207 (c): The device shall automatically discontinue transmission in case of either absence of information to transmit or operational failure. These provisions are not intended to preclude the transmission of control or signaling information or the use of repetitive codes used by certain digital technologies to complete frame or burst intervals.

**Test Results:** The EUT was not applicable with the requirement of this section.

## Electromagnetic Compatibility Criteria for Intentional Radiators

### § 15.407(e) 6 dB Bandwidth

**Test Requirements:** § 15.407(e): Within the 5.725-5.85 GHz band, the minimum 6 dB bandwidth of U-NII devices shall be at least 500 kHz.

**Test Procedure:** The transmitter was set to low, mid, and high operating frequencies at the highest output power and connected to the spectrum analyzer through an attenuator. The bandwidth of the fundamental frequency was measured with the spectrum analyzer using a RBW approximately equal to 1% of the total emission bandwidth, VBW > RBW. The 6 dB Bandwidth was measured and recorded.

**Test Results** The 6 dB Bandwidth was compliant with the requirements of this section.

No anomalies detected.

**Test Engineer(s):** Saeed KabirSalmani

**Test Date(s):** November 18, 2016

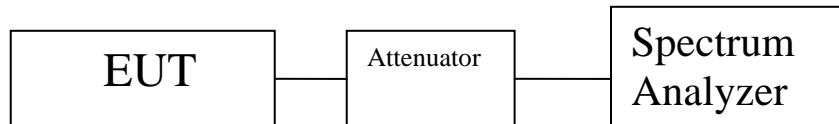

OBW			
	Channel	Frequency (MHz)	6dB OBW (MHz)
802.11a 20MHz Port R11	Low	5745	16.38
	Mid	5785	16.39
	High	5805	16.4
802.11n 20MHz Port R11	Low	5745	17.74
	Mid	5785	17.71
	High	5805	17.67

**Table 18. Occupied Bandwidth, 20 MHz, Test Results**

OBW			
	Channel	Frequency (MHz)	6dB OBW (MHz)
802.11n 40MHz Port R11	Low	5755	36.51
	High	5795	36.56

**Table 19. Occupied Bandwidth, 40 MHz Test Results**

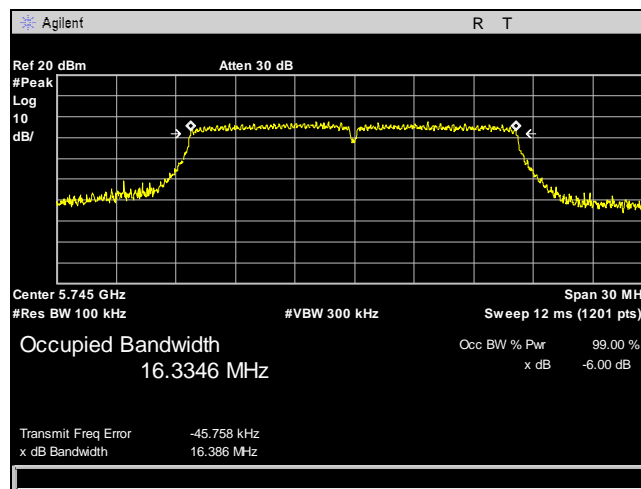

**Plot 58. 6 dB Occupied Bandwidth, 802.11a, 20 MHz, Ch. 5745 MHz, R11**

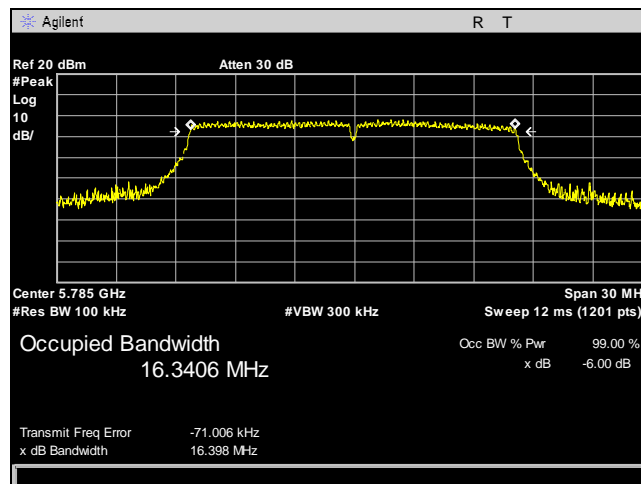

**Plot 59. 6 dB Occupied Bandwidth, 802.11a, 20 MHz, Ch. 5785 MHz, R11**

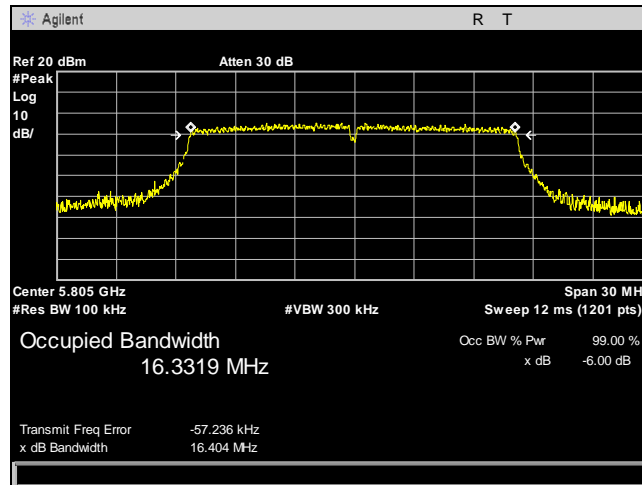

Plot 60. 6 dB Occupied Bandwidth, 802.11a, 20 MHz, Ch. 5805 MHz, R11

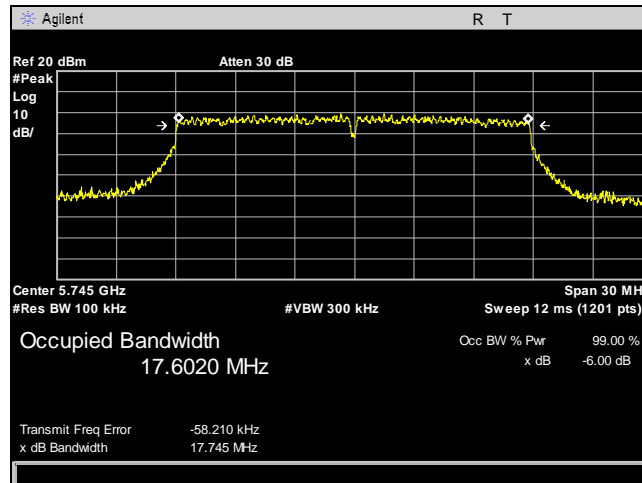

Plot 61. 6 dB Occupied Bandwidth, 802.11a, 20 MHz, Ch. 5745 MHz, R11

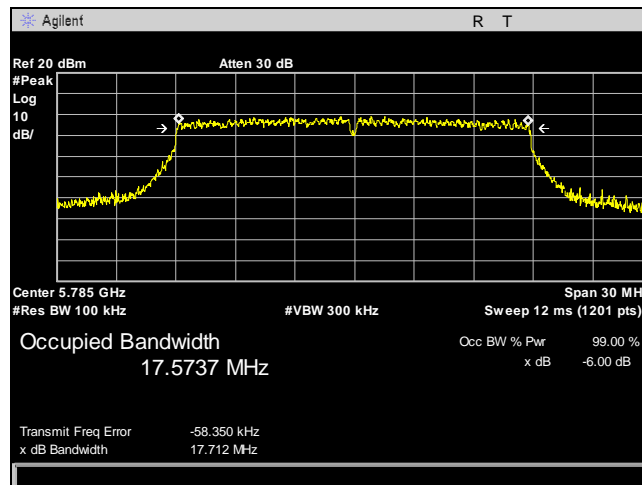

Plot 62. 6 dB Occupied Bandwidth, 802.11a, 20 MHz, Ch. 5785 MHz, R11

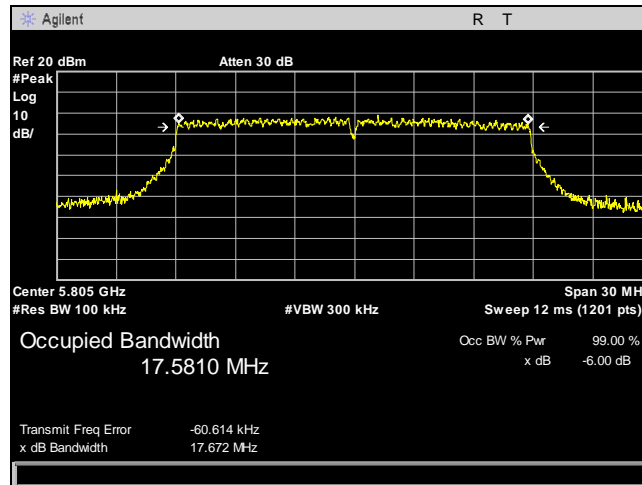

Plot 63. 6 dB Occupied Bandwidth, 802.11a, 20 MHz, Ch. 5805 MHz, R11

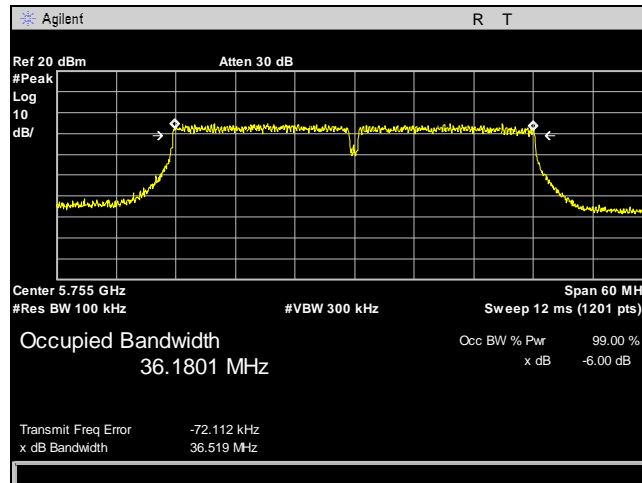

Plot 64. 6 dB Occupied Bandwidth, 802.11a, 40 MHz, Ch. 5755 MHz, R11

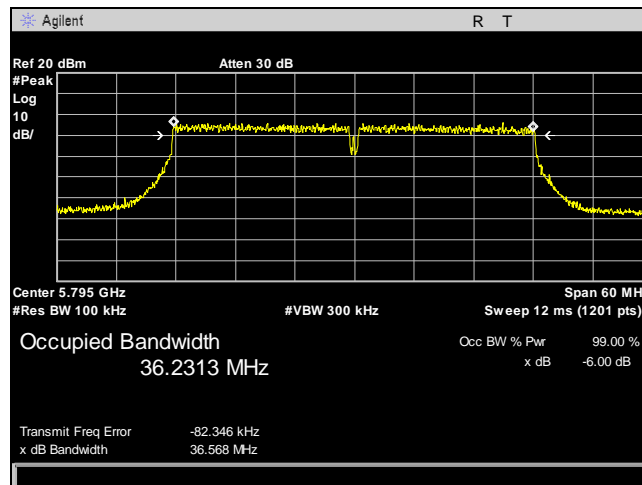

Plot 65. 6 dB Occupied Bandwidth, 802.11a, 40 MHz, Ch. 5795 MHz, R11

## Electromagnetic Compatibility Criteria for Intentional Radiators

### § 15.407(f) Maximum Permissible Exposure

**Test Requirement(s):** §15.407(f): U-NII devices are subject to the radio frequency radiation exposure requirements specified in §1.1307(b), §2.1091 and §2.1093 of this chapter, as appropriate. All equipment shall be considered to operate in a “general population/uncontrolled” environment.

**RF Exposure Requirements:** §1.1307(b)(1) and §1.1307(b)(2): Systems operating under the provisions of this section shall be operated in a manner that ensures that the public is not exposed to radio frequency energy levels in excess of the Commission’s guidelines.

**RF Radiation Exposure Limit:** §1.1310: As specified in this section, the Maximum Permissible Exposure (MPE) Limit shall be used to evaluate the environmental impact of human exposure to radiofrequency (RF) radiation as specified in Sec. 1.1307(b), except in the case of portable devices which shall be evaluated according to the provisions of Sec. 2.1093 of this chapter.

MPE Limit: EUT’s operating frequencies @ 5725 - 5850 MHz; **Limit for Uncontrolled exposure: 1 mW/cm<sup>2</sup> or 10 W/m<sup>2</sup>**

Equation from page 18 of OET 65, Edition 97-01

$$S = PG / 4\pi R^2 \quad \text{or} \quad R = \sqrt{PG / 4\pi S}$$

where, S = Power Density (mW/cm<sup>2</sup>)  
P = Power Input to antenna (mW)  
G = Antenna Gain (numeric value)  
R = Distance (cm)

#### Test Results:

FCC									
Frequency (MHz)	Con. Pwr. (dBm)	Con. Pwr. (mW)	Ant. Gain (dBi)	Ant. Gain numeric	Pwr. Density (mW/cm <sup>2</sup> )	Limit (mW/cm <sup>2</sup> )	Margin	Distance (cm)	Result
5745	19.65	92.257	16	39.811	0.73068	1	0.26932	20	Pass

Table 20. RF Exposure, FCC, UNII 3, 16 dBi

FCC									
Frequency (MHz)	Con. Pwr. (dBm)	Con. Pwr. (mW)	Ant. Gain (dBi)	Ant. Gain numeric	Pwr. Density (mW/cm <sup>2</sup> )	Limit (mW/cm <sup>2</sup> )	Margin	Distance (cm)	Result
5795	16.45	44.157	19	79.433	0.6978	1	0.3022	20	Pass



**Table 21. RF Exposure, FCC, UNII 3, 19 dBi**

FCC									
Frequency (MHz)	Con. Pwr. (dBm)	Con. Pwr. (mW)	Ant. Gain (dBi)	Ant. Gain numeric	Pwr. Density (mW/cm <sup>2</sup> )	Limit (mW/cm <sup>2</sup> )	Margin	Distance (cm)	Result
5795	26.57	453.942	9	7.943	0.71735	1	0.28265	20	Pass

**Table 22. RF Exposure, FCC, UNII 3, 9 dBi**

The safe distance where Power Density is less than the MPE Limit listed above was found to be 20 cm.

## Electromagnetic Compatibility Criteria for Intentional Radiators

### § 15.407(g) Frequency Stability

**Test Requirements:** Manufacturers of U-NII devices are responsible for ensuring frequency stability such that an emission is maintained within the band of operation under all conditions of normal operation as specified in the user's manual.

**Test Results:** The EUT was not applicable with the requirements of this section.

## IV. Test Equipment

## Test Equipment

Calibrated test equipment utilized during testing was maintained in a current state of calibration per the requirements of ISO/IEC 17025:2005.

MET Asset #	Equipment	Manufacturer	Model	Last Cal Date	Cal Due Date
1S3914	Spikeguard	FCC	FCC-450B-2.4-N	See Note	See Note
1S3809	EMI CISPR Receiver	Narda Safety Test Solutions	PMM 9010F	2/1/2016	2/1/2017
1U0337	AC LISN	Com Power	LI-215A	5/31/2016	5/31/2017
1S2657	Screen Room	ETS Lindgren	14w-2/2-0	Not Required	Not Required
1S2746	Bilog Antenna	Sunol Science	JB3	9/29/2015	3/29/2017
1S2482	5 Meter Chamber (NSA)	Panashield	5 Meter Semi-Anechoic Chamber	See Note	See Note
1S2603	Double Ridged Waveguide Horn	ETS-Lindgren	3117	08/09/2016	08/09/18
1S3962	Spectrum Analyzer (PSA)	Keysight/Agilent	E4448A	02/26/16	02/26/2018
1S2121	Pre-Amplifier	Hewlett Packard	8449B	See Note	See Note
1U0258	Spectrum Analyzer	Agilent Technologies	E4407B	2/2/2016	2/2/2017

**Table 23. Test Equipment List**

Note: Functionally tested equipment is verified using calibrated instrumentation at the time of testing.

## **V. Certification & User's Manual Information**

## Certification & User's Manual Information

### K. Certification Information

The following is extracted from Title 47 of the Code of Federal Regulations, Part 2, Subpart I — Marketing of Radio frequency devices:

#### § 2.801 Radio-frequency device defined.

As used in this part, a radio-frequency device is any device which in its operation is capable of Emitting radio-frequency energy by radiation, conduction, or other means. Radio- frequency devices include, but are not limited to:

- (a) The various types of radio communication transmitting devices described throughout this chapter.
- (b) *The incidental, unintentional and intentional radiators defined in Part 15 of this chapter.*
- (c) The industrial, scientific, and medical equipment described in Part 18 of this chapter.
- (d) Any part or component thereof which in use emits radio-frequency energy by radiation, conduction, or other means.

#### § 2.803 Marketing of radio frequency devices prior to equipment authorization.

- (a) Except as provided elsewhere in this chapter, no person shall sell or lease, or offer for sale or lease (including advertising for sale or lease), or import, ship or distribute for the purpose of selling or leasing or offering for sale or lease, any radio frequency device unless:
  - (1) In the case of a device subject to certification, such device has been authorized by the Commission in accordance with the rules in this chapter and is properly identified and labeled as required by §2.925 and other relevant sections in this chapter; or
  - (2) In the case of a device that is not required to have a grant of equipment authorization issued by the Commission, but which must comply with the specified technical standards prior to use, such device also complies with all applicable administrative (including verification of the equipment or authorization under a Declaration of Conformity, where required), technical, labeling and identification requirements specified in this chapter.
- (d) Notwithstanding the provisions of paragraph (a) of this section, the offer for sale solely to business, commercial, industrial, scientific or medical users (but not an offer for sale to other parties or to end users located in a residential environment) of a radio frequency device that is in the conceptual, developmental, design or pre-production stage is permitted prior to equipment authorization or, for devices not subject to the equipment authorization requirements, prior to a determination of compliance with the applicable technical requirements *provided* that the prospective buyer is advised in writing at the time of the offer for sale that the equipment is subject to the FCC rules and that the equipment will comply with the appropriate rules before delivery to the buyer or to centers of distribution.

- (e)(1) Notwithstanding the provisions of paragraph (a) of this section, prior to equipment authorization or determination of compliance with the applicable technical requirements any radio frequency device may be operated, but not marketed, for the following purposes and under the following conditions:
- (i) *Compliance testing;*
  - (ii) Demonstrations at a trade show provided the notice contained in paragraph (c) of this section is displayed in a conspicuous location on, or immediately adjacent to, the device;
  - (iii) Demonstrations at an exhibition conducted at a business, commercial, industrial, scientific or medical location, but excluding locations in a residential environment, provided the notice contained in paragraphs (c) or (d) of this section, as appropriate, is displayed in a conspicuous location on, or immediately adjacent to, the device;
  - (iv) Evaluation of product performance and determination of customer acceptability, provided such operation takes place at the manufacturer's facilities during developmental, design or pre-production states; or
  - (v) Evaluation of product performance and determination of customer acceptability where customer acceptability of a radio frequency device cannot be determined at the manufacturer's facilities because of size or unique capability of the device, provided the device is operated at a business, commercial, industrial, scientific or medical user's site, but not at a residential site, during the development, design or pre-production stages.
- (e)(2) For the purpose of paragraphs (e)(1)(iv) and (e)(1)(v) of this section, the term *manufacturer's facilities* includes the facilities of the party responsible for compliance with the regulations and the manufacturer's premises, as well as the facilities of other entities working under the authorization of the responsible party in connection with the development and manufacture, but not the marketing, of the equipment.
- (f) For radio frequency devices subject to verification and sold solely to business, commercial, industrial, scientific and medical users (excluding products sold to other parties or for operation in a residential environment), parties responsible for verification of the devices shall have the option of ensuring compliance with the applicable technical specifications of this chapter at each end user's location after installation, provided that the purchase or lease agreement includes a proviso that such a determination of compliance be made and is the responsibility of the party responsible for verification of the equipment.

## Certification & User's Manual Information

The following is extracted from Title 47 of the Code of Federal Regulations, Part 2, Subpart J — Equipment Authorization Procedures:

### § 2.901 Basis and Purpose

- (a) In order to carry out its responsibilities under the Communications Act and the various treaties and international regulations, and in order to promote efficient use of the radio spectrum, the Commission has developed technical standards for radio frequency equipment and parts or components thereof. The technical standards applicable to individual types of equipment are found in that part of the rules governing the service wherein the equipment is to be operated.<sup>1</sup> *In addition to the technical standards provided, the rules governing the service may require that such equipment be verified by the manufacturer or importer, be authorized under a Declaration of Conformity, or receive an equipment authorization from the Commission by one of the following procedures: certification or registration.*
- (b) The following sections describe the verification procedure, the procedure for a Declaration of Conformity, and the procedures to be followed in obtaining certification from the Commission and the conditions attendant to such a grant.

### § 2.907 Certification.

- (a) Certification is an equipment authorization issued by the Commission, based on representation and test data submitted by the applicant.
- (b) Certification attaches to all units subsequently marketed by the grantee which are identical (see Section 2.908) to the sample tested except for permissive changes or other variations authorized by the Commission pursuant to Section 2.1043.

---

<sup>1</sup> In this case, the equipment is subject to the rules of Part 15. More specifically, the equipment falls under Subpart B (of Part 15), which deals with unintentional radiators.



## Certification & User's Manual Information

### § 2.948 Description of measurement facilities.

- (a) Each party making measurements of equipment that is subject to an equipment authorization under Part 15 or Part 18 of this chapter, regardless of whether the measurements are filed with the Commission or kept on file by the party responsible for compliance of equipment marketed within the U.S. or its possessions, shall compile a description of the measurement facilities employed.
- (1) If the measured equipment is subject to the verification procedure, the description of the measurement facilities shall be retained by the party responsible for verification of the equipment.
- (i) *If the equipment is verified through measurements performed by an independent laboratory, it is acceptable for the party responsible for verification of the equipment to rely upon the description of the measurement facilities retained by or placed on file with the Commission by that laboratory. In this situation, the party responsible for the verification of the equipment is not required to retain a duplicate copy of the description of the measurement facilities.*
- (ii) If the equipment is verified based on measurements performed at the installation site of the equipment, no specific site calibration data is required. It is acceptable to retain the description of the measurement facilities at the site at which the measurements were performed.
- (2) If the equipment is to be authorized by the Commission under the certification procedure, the description of the measurement facilities shall be filed with the Commission's Laboratory in Columbia, Maryland. The data describing the measurement facilities need only be filed once but must be updated as changes are made to the measurement facilities or as otherwise described in this section. At least every three years, the organization responsible for filing the data with the Commission shall certify that the data on file is current.

## Certification & User's Manual Information

### Label and User's Manual Information

The following is extracted from Title 47 of the Code of Federal Regulations, Part 15, Subpart A — General:

#### § 15.19 Labeling requirements.

(a) *In addition to the requirements in Part 2 of this chapter, a device subject to certification or verification shall be labeled as follows:*

- (1) Receivers associated with the operation of a licensed radio service, e.g., FM broadcast under Part 73 of this chapter, land mobile operation under Part 90, etc., shall bear the following statement in a conspicuous location on the device:

This device complies with Part 15 of the FCC Rules. Operation is subject to the condition that this device does not cause harmful interference.

- (2) A stand-alone cable input selector switch, shall bear the following statement in a conspicuous location on the device:

This device is verified to comply with Part 15 of the FCC Rules for use with cable television service.

- (3) All other devices shall bear the following statement in a conspicuous location on the device:

*This device complies with Part 15 of the FCC Rules. Operation is subject to the following two conditions: (1) This device may not cause harmful interference, and (2) this device must accept any interference received, including interference that may cause undesired operation.*

- (4) Where a device is constructed in two or more sections connected by wires and marketed together, the statement specified under paragraph (a) of this section is required to be affixed only to the main control unit.

- (5) When the device is so small or for such use that it is not practicable to place the statement specified under paragraph (a) of this section on it, the information required by this paragraph shall be placed in a prominent location in the instruction manual or pamphlet supplied to the user or, alternatively, shall be placed on the container in which the device is marketed. However, the FCC identifier or the unique identifier, as appropriate, must be displayed on the device.

#### § 15.21 Information to user.

The users manual or instruction manual for an intentional or unintentional radiator shall caution the user that changes or modifications not expressly approved by the party responsible for compliance could void the user's authority to operate the equipment.

## Verification & User's Manual Information

The following is extracted from Title 47 of the Code of Federal Regulations, Part 15, Subpart B — Unintentional Radiators:

### § 15.105 Information to the user.

- (a) For a Class A digital device or peripheral, the instructions furnished the user shall include the following or similar statement, placed in a prominent location in the text of the manual:

Note: This equipment has been tested and found to comply with the limits for a Class A digital device, pursuant to Part 15 of the FCC Rules. These limits are designed to provide reasonable protection against harmful interference when the equipment is operated in a commercial environment. This equipment generates, uses, and can radiate radio frequency energy and, if not installed and used in accordance with the instruction manual, may cause harmful interference to radio communications. Operation of this equipment in a residential area is likely to cause harmful interference in which case the user will be required to correct the interference at own expense.

- (b) For a Class B digital device or peripheral, the instructions furnished the user shall include the following or similar statement, placed in a prominent location in the text of the manual:

Note: This equipment has been tested and found to comply with the limits for a Class B digital device, pursuant to Part 15 of the FCC Rules. These limits are designed to provide reasonable protection against harmful interference when the equipment is operated in a residential environment. This equipment generates, uses, and can radiate radio frequency energy and, if not installed and used in accordance with the instruction manual, may cause harmful interference to radio communications. However, there is no guarantee that interference will not occur in a particular installation. If this equipment does cause harmful interference to radio or television reception, which can be determined by turning the equipment off and on, the user is encouraged to try to correct the interference by one or more of the following measures:

- Reorient or relocate the receiving antenna.
- Increase the separation between the equipment and receiver.
- Connect the equipment into an outlet on a circuit different from that to which the receiver is connected.
- Consult the dealer or an experienced radio/TV technician for help.

# End of Report