



MET Laboratories, Inc. *Safety Certification - EMI - Telecom Environmental Simulation*

914 WEST PATAPSCO AVENUE • BALTIMORE, MARYLAND 21230-3432 • PHONE (410) 354-3300 • FAX (410) 354-3313
33439 WESTERN AVENUE • UNION CITY, CALIFORNIA 94587 • PHONE (510) 489-6300 • FAX (510) 489-6372
3162 BELICK STREET • SANTA CLARA, CALIFORNIA 95054 • PHONE (408) 748-3585 • FAX (510) 489-6372
13501 MCCALLEN PASS • AUSTIN, TX 78753 • PHONE (512) 287-2500 • FAX (512) 287-2513

February 20, 2017

Firetide, Inc.
2105 South Bascom Avenue
Suite 220
Campbell, CA 95008

Dear Sudhir Hirudayaraj,

Enclosed is the EMC Wireless test report for compliance testing of the Firetide, Inc. , 7010(W) as tested to the requirements of Title 47 of the CFR, Ch. 1 (10-1-06 ed.), Title 47 of the CFR, Part 15.407, Subpart E (UNII 1).

Thank you for using the services of MET Laboratories, Inc. If you have any questions regarding these results or if MET can be of further service to you, please feel free to contact me.

Sincerely yours,
MET LABORATORIES, INC.

Joel Huna
Documentation Department

Reference: (\Firetide, Inc. \EMCS92597-FCC407 UNII 1 Rev. 1)

Certificates and reports shall not be reproduced except in full, without the written permission of MET Laboratories, Inc.



MET Laboratories, Inc. *Safety Certification - EMI - Telecom Environmental Simulation*

914 WEST PATAPSCO AVENUE • BALTIMORE, MARYLAND 21230-3432 • PHONE (410) 354-3300 • FAX (410) 354-3313

33439 WESTERN AVENUE • UNION CITY, CALIFORNIA 94587 • PHONE (510) 489-6300 • FAX (510) 489-6372

3162 BELICK STREET • SANTA CLARA, CALIFORNIA 95054 • PHONE (408) 748-3585 • FAX (510) 489-6372

13501 MCCALLEN PASS • AUSTIN, TX 78753 • PHONE (512) 287-2500 • FAX (512) 287-2513

**Electromagnetic Compatibility Criteria
Test Report**

for the

**Firetide, Inc.
Model 7010(W)**

Tested under
The FCC Certification Rules
contained in
Title 47 of the CFR
15.407 Subpart E

MET Report: EMCS92597-FCC407 UNII 1 Rev. 1

February 20, 2017

Prepared For:

**Firetide, Inc.
2105 South Bascom Avenue Suite 220
Campbell, CA 95008**

Prepared By:
MET Laboratories, Inc.
6162 Belick St., Santa Clara,
CA 95054

Electromagnetic Compatibility Criteria Test Report

for the

Firetide, Inc.
Model 7010(W)

Tested under
The FCC Certification Rules
contained in
Title 47 of the CFR
15.407 Subpart E



Jun Qi, Project Engineer
Electromagnetic Compatibility Lab



Joel Huna
Documentation Department

Engineering Statement: The measurements shown in this report were made in accordance with the procedures indicated, and the emissions from this equipment were found to be within the limits applicable. I assume full responsibility for the accuracy and completeness of these measurements, and for the qualifications of all persons taking them. It is further stated that upon the basis of the measurements made, the equipment tested is capable of operation in accordance with the requirements of Parts 15B, 15.407, of the FCC Rules under normal use and maintenance.



Asad Bajwa,
Director, Electromagnetic Compatibility Lab

Report Status Sheet

Revision	Report Date	Reason for Revision
∅	January 30, 2017	Initial Issue.
1	February 20, 2017	Engineer corrections.

Table of Contents

I.	Executive Summary	1
	A. Purpose of Test	2
	B. Executive Summary	2
II.	Equipment Configuration	3
	A. Overview.....	4
	B. References.....	5
	C. Test Site	5
	D. Description of Test Sample.....	5
	E. Equipment Configuration.....	7
	F. Support Equipment	7
	G. Ports and Cabling Information.....	7
	H. Mode of Operation.....	8
	I. Method of Monitoring EUT Operation	8
	J. Modifications	8
	a) Modifications to EUT	8
	b) Modifications to Test Standard	8
	K. Disposition of EUT	8
III.	Electromagnetic Compatibility Criteria for Intentional Radiators.....	9
	§ 15.203 Antenna Requirement.....	10
	§ 15.403(i) 26dB Bandwidth	11
	§ 15.407(a)(1) Maximum Conducted Output Power	15
	§ 15.407(a)(1) Maximum Power Spectral Density	22
	§ 15.407(b) & (6 - 7) Undesirable Emissions	26
	§ 15.407(b)(6) Conducted Emissions	54
	§ 15.207(c) Automatic Discontinue of Transmission	57
	§ 15.247(i) Maximum Permissible Exposure	58
	§ 15.407(g) Frequency Stability	60
IV.	Test Equipment	61
V.	Certification & User's Manual Information	63
	A. Certification Information	64
	B. Label and User's Manual Information	68

List of Tables

Table 1. Executive Summary of EMC Part 15.407 Compliance Testing	2
Table 2. EUT Summary.....	4
Table 3. References	5
Table 4. Equipment Configuration	7
Table 5. Support Equipment.....	7
Table 6. Ports and Cabling Information	7
Table 7. 26 dB Occupied Bandwidth, Test Results	14
Table 8. Maximum Conducted Output Power, UNII 1 20 MHz, Peak Conducted Output Power	17
Table 9. Maximum Conducted Output Power, UNII 1 20 MHz Summed Peak Conducted Output Power	18
Table 10. Maximum Conducted Power, UNII 1 40 MHz, Peak Conducted Output Power	19
Table 11. Maximum Conducted Power, UNII 40 MHz, Summed Peak Conducted Output Power	19
Table 12. Power Spectral Density, Peak Conducted 20MHz Output Power	23
Table 13. Power Spectral Density, Summed Peak Conducted Output Power 20MHz	24
Table 14. Power Spectral Density, Summed Peak Conducted Output Power 40MHz	25
Table 15. Conducted Limits for Intentional Radiators from FCC Part 15 § 15.207(a)	54
Table 16. Conducted Emissions, 15.207(a), Line 1, Test Results	55
Table 17. Conducted Emissions, 15.207(a), Neutral, Test Results	56
Table 18. Test Equipment List	62

List of Figures

Figure 1. Block Diagram of Test Configuration.....	6
--	---

List of Plots

Plot 1. 26 dB Occupied Bandwidth, 802.11a, 20MHz, Ch. 5180 MHz, R11	12
Plot 2. 26 dB Bandwidth, 802.11a, 20MHz, Ch. 5200 MHz, R11	12
Plot 3. 26 dB Bandwidth, 802.11a, 20MHz, Ch. 5240MHz, R11	12
Plot 4. 26 dB Bandwidth, 802.11n, 20 MHz, Ch. 5180 MHz, R11	13
Plot 5. 26 dB Bandwidth, 802.1n, 20 MHz, 5200 MHz, R11.....	13
Plot 6. 26 dB Bandwidth, 802.11n, 20 MHz, 5240MHz, R11.....	13
Plot 7. 26 dB Bandwidth, 802.11n, 40 MHz, 5190MHz, R11.....	14
Plot 8. 26 dB Bandwidth, 802.11n, 40 MHz, 5230 MHz, R11.....	14
Plot 9. Radio Spurious Emission, 1 GHz - 18 GHz - 27 dBm, Bandwidth 20M, Ch. 5180M, a mode, TP15, 9dBi.....	27
Plot 10. Radio Spurious Emission, 1 GHz - 18 GHz - 27 dBm, Bandwidth 20M, Ch. 5180M, n mode, TP15, 9 dBi.....	27
Plot 11. Radio Spurious Emission, 1 GHz - 18 GHz - 27 dBm, Bandwidth 20M, Ch. 5200M, a mode, TP22, 9 dBi.....	27
Plot 12. Radio Spurious Emission, 1 GHz - 18 GHz - 27 dBm, Bandwidth 20M, Ch. 5200M, n mode, TP21, 9 dBi.....	28
Plot 13. Radio Spurious Emission, 1 GHz - 18 GHz - 27 dBm, Bandwidth 20M, Ch. 5240M, a mode, TP22, 9 dBi.....	28
Plot 14. Radio Spurious Emission, 1 GHz - 18 GHz - 27 dBm, Bandwidth 20M, Ch. 5240M, n mode, TP22, 9 dBi.....	28
Plot 15. Radio Spurious Emission, 1 GHz - 18 GHz - 27 dBm, Bandwidth 40M, Ch. 5190M, n mode, TP9m 9 dBi.....	29
Plot 16. Radio Spurious Emission, 1 GHz - 18 GHz - 27 dBm, Bandwidth 40M, Ch. 5230M, n mode, TP15, 9 dBi.....	29
Plot 17. Radio Spurious Emission, 1 GHz - 18 GHz - 27 dBm, Bandwidth 40M, Ch. 5230M, n mode, TP18, 16 dBi.....	29
Plot 18. Radio Spurious Emission, 1 GHz - 18 GHz - 27 dBm, Bandwidth 40M, Ch. 5190M, n mode, TP7.5, 16 dBi.....	30
Plot 19. Radio Spurious Emission, 1 GHz - 18 GHz - 27 dBm, Bandwidth 20M, Ch. 5240M, n mode, TP17, 16 dBi.....	30
Plot 20. Radio Spurious Emission, 1 GHz - 18 GHz - 27 dBm, Bandwidth 20M, Ch. 5240M, a mode, TP17, 16 dBi.....	30
Plot 21. Radio Spurious Emission, 1 GHz - 18 GHz - 27 dBm, Bandwidth 20M, Ch. 5200M, n mode, TP17, 16 dBi.....	31
Plot 22. Radio Spurious Emission, 1 GHz - 18 GHz - 27 dBm, Bandwidth 20M, Ch. 5200M, a mode, TP17, 16 dBi.....	31
Plot 23. Radio Spurious Emission, 1 GHz - 18 GHz - 27 dBm, Bandwidth 20M, Ch. 5180M, n mode, TP15, 16 dBi.....	31
Plot 24. Radio Spurious Emission, 1 GHz - 18 GHz - 27 dBm, Bandwidth 20M, Ch. 5180M, a mode, TP17, 16 dBi.....	32
Plot 25. Radio Spurious Emission, 1 GHz - 18 GHz - 27 dBm, Bandwidth 40M, Ch. 5230M, n mode, TP11, 19 dBi.....	32
Plot 26. Radio Spurious Emission, 1 GHz - 18 GHz - 27 dBm, Bandwidth 40M, Ch. 5190M, n mode, TP6.5, 19 dBi.....	32
Plot 27. Radio Spurious Emission, 1 GHz - 18 GHz - 27 dBm, Bandwidth 20M, Ch. 5240M, n mode, TP9, 19 dBi.....	33

Plot 28. Radio Spurious Emission, 1 GHz - 18 GHz - 27 dBm, Bandwidth 20M, Ch. 5240M, a mode, TP9, 19 dBi	33
Plot 29. Radio Spurious Emission, 1 GHz - 18 GHz - 27 dBm, Bandwidth 20M, Ch. 5200M, n mode, TP9, 19 dBi	33
Plot 30. Radio Spurious Emission, 1 GHz - 18 GHz - 27 dBm, Bandwidth 20M, Ch. 5200M, a mode, TP9, 19 dBi	34
Plot 31. Radio Spurious Emission, 1 GHz - 18 GHz - 27 dBm, Bandwidth 20M, Ch. 5180M, n mode, TP9, 19 dBi	34
Plot 32. Radio Spurious Emission, 1 GHz - 18 GHz - 27 dBm, Bandwidth 20M, Ch. 5180M, a mode, TP9, 19 dBi	34
Plot 33. Restricted Band of Operation, 11a, 20MHz, 5180 MHz, OP 15 dB, Average 9 dBi	35
Plot 34. Restricted Band of Operation, 11a, 20MHz, 5180 MHz, OP 15 dB, Peak 9 dBi	35
Plot 35. Restricted Band of Operation, 11a, 20MHz, 5200 MHz, OP 22 dB, Average 9 dBi	35
Plot 36. Restricted Band of Operation, 11a, 20MHz, 5200 MHz, OP 22 dB, Peak 9 dBi	36
Plot 37. Restricted Band of Operation, 11a, 20MHz, 5240 MHz, OP 22 dB, Average 9 dBi	36
Plot 38. Restricted Band of Operation, 11a, 20MHz, 5240 MHz, OP 22 dB, Peak, 9 dBi	36
Plot 39. Restricted Band of Operation, 11n, 20MHz, 5180 MHz, OP 15 dB, Average, 9 dBi	37
Plot 40. Restricted Band of Operation, 11n, 20MHz, 5180 MHz, OP 15 dB, Peak 9 dBi	37
Plot 41. Restricted Band of Operation, 11n, 20MHz, 5200 MHz, OP 21 dB, Average 9 dBi	37
Plot 42. Restricted Band of Operation, 11n, 20MHz, 5200 MHz, OP 21 dB, Peak 9 dBi	38
Plot 43. Restricted Band of Operation, 11n, 40MHz, 5230 MHz, OP 18 dB, Peak 9 dBi	38
Plot 44. Restricted Band of Operation, 11n, 40MHz, 5230 MHz, OP 18 dB, Average 9 dBi	38
Plot 45. Restricted Band of Operation, 11n, 40MHz, 5190 MHz, OP 9 dB, Peak 9 dBi	39
Plot 46. Restricted Band of Operation, 11n, 40MHz, 5190 MHz, OP 9 dB, Average 9 dBi	39
Plot 47. Restricted Band of Operation, 11n, 20MHz, 5240 MHz, OP 22 dB, Peak 9 dBi	39
Plot 48. Restricted Band of Operation, 11n, 20MHz, 5240 MHz, OP 22 dB, Average 9 dBi	40
Plot 49. Restricted Band of Operation, 11a, 20MHz, 5180 MHz, OP 17 dB, Average 16 dBi	40
Plot 50. Restricted Band of Operation, 11a, 20MHz, 5180 MHz, OP 17 dB, Peak, 16 dBi	40
Plot 51. Restricted Band of Operation, 11a, 20MHz, 5200 MHz, OP 17 dB, Average, 16 dBi	41
Plot 52. Restricted Band of Operation, 11a, 20MHz, 5200 MHz, OP 17 dB, Peak 16 dBi	41
Plot 53. Restricted Band of Operation, 11a, 20MHz, 5240 MHz, OP 17 dB, Average 16 dBi	41
Plot 54. Restricted Band of Operation, 11a, 20MHz, 5240 MHz, OP 17 dB, Peak 16 dBi	42
Plot 55. Restricted Band of Operation, 11n, 20MHz, 5180 MHz, OP 15 dB, Average 16 dBi	42
Plot 56. Restricted Band of Operation, 11n, 20MHz, 5180 MHz, OP 15 dB, Peak 16 dBi	42
Plot 57. Restricted Band of Operation, 11n, 20MHz, 5200 MHz, OP 17 dB, Average dBi	43
Plot 58. Restricted Band of Operation, 11n, 20MHz, 5200 MHz, OP 17 dB, Peak 16 dBi	43
Plot 59. Restricted Band of Operation, 11n, 40MHz, 5230 MHz, OP 18 dB, Peak 16 dBi	43
Plot 60. Restricted Band of Operation, 11n, 40MHz, 5230 MHz, OP 18 dB, Average 16 dBi	44
Plot 61. Restricted Band of Operation, 11n, 40MHz, 5190 MHz, OP 7.5 dB, Peak 16 dBi	44
Plot 62. Restricted Band of Operation, 11n, 40MHz, 5190 MHz, OP 7.5 dB, Average 16 dBi	44
Plot 63. Restricted Band of Operation, 11n, 20MHz, 5240 MHz, OP 17 dB, Peak 16 dBi	45
Plot 64. Restricted Band of Operation, 11n, 20MHz, 5240 MHz, OP 17 dB, Average 16 dBi	45
Plot 65. Restricted Band of Operation, 11a, 20MHz, 5180 MHz, OP 9 dB, Average 19 dBi	45
Plot 66. Restricted Band of Operation, 11a, 20MHz, 5180 MHz, OP 9 dB, Peak 19 dBi	46
Plot 67. Restricted Band of Operation, 11a, 20MHz, 5200 MHz, OP 9 dB, Average 19 dBi	46
Plot 68. Restricted Band of Operation, 11a, 20MHz, 5200 MHz, OP 9 dB, Peak 19 dBi	46
Plot 69. Restricted Band of Operation, 11a, 20MHz, 5240 MHz, OP 9 dB, Average 19 dBi	47
Plot 70. Restricted Band of Operation, 11a, 20MHz, 5240 MHz, OP 9 dB, Peak 19 dBi	47
Plot 71. Restricted Band of Operation, 11n, 20MHz, 5180 MHz, OP 9 dB, Average 19 dBi	47
Plot 72. Restricted Band of Operation, 11n, 20MHz, 5180 MHz, OP 9 dB, Peak 19 dBi	48
Plot 73. Restricted Band of Operation, 11n, 20MHz, 5200 MHz, OP 9 dB, Average 19 dBi	48
Plot 74. Restricted Band of Operation, 11n, 20MHz, 5200 MHz, OP 9 dB, Peak 19 dBi	48
Plot 75. Restricted Band of Operation, 11n, 40MHz, 5230 MHz, OP 11 dB, Peak 19 dBi	49
Plot 76. Restricted Band of Operation, 11n, 40MHz, 5230 MHz, OP 11 dB, Average 19 dBi	49
Plot 77. Restricted Band of Operation, 11n, 40MHz, 5190 MHz, OP 6.5 dB, Peak 19 dBi	49
Plot 78. Restricted Band of Operation, 11n, 40MHz, 5190 MHz, OP 6.5 dB, Average 19 dBi	50
Plot 79. Restricted Band of Operation, 11n, 20MHz, 5240 MHz, OP 9 dB, Peak 19 dBi	50
Plot 80. Restricted Band of Operation, 11n, 20MHz, 5240 MHz, OP 9 dB, Average 19 dBi	50
Plot 81. Radiated Spurious Emissions, 11n, 40 MHz, Low, 5190 MHz, OP 23.5 dB, Average 9 dBi	51
Plot 82. Radiated Spurious Emissions, 11n, 40 MHz, High, 5230 MHz, OP 23.5 dB, Average 9 dBi	51
Plot 83. Radiated Spurious Emissions, 11n, 40 MHz, Low, 5190 MHz, OP 19 dB, Average 16 dBi	51
Plot 84. Radiated Spurious Emissions, 11n, 40 MHz, High, 5230 MHz, OP 19 dB, Average 16 dBi	52

Plot 85. Radiated Spurious Emissions, 11n, 40 MHz, Low, 5190 MHz, OP 11 dB, Average 19 dBi.....	52
Plot 86. Radiated Spurious Emissions, 11n, 40 MHz, High, 5230 MHz, OP 11 dB, Average 19 dBi	52
Plot 87. Radiated Spurious Emissions, No Radiate, Power on Only	53
Plot 88. Conducted Emissions, 15.207(a), Line 1	55
Plot 89. Conducted Emissions, 15.207(a), Neutral Line	56
Plot 90. RF Exposure, FCC UNII 1, 16 dBi	58
Plot 91. RF Exposure, FCC UNII 1, 19 dBi.....	58
Plot 92. RF Exposure, FCC UNII 1, 9 dBi.....	59

List of Terms and Abbreviations

AC	Alternating Current
ACF	Antenna Correction Factor
Cal	Calibration
<i>d</i>	Measurement Distance
dB	Decibels
dBμA	Decibels above one microamp
dBμV	Decibels above one microvolt
dBμA/m	Decibels above one microamp per meter
dBμV/m	Decibels above one microvolt per meter
DC	Direct Current
E	Electric Field
DSL	Digital Subscriber Line
ESD	Electrostatic Discharge
EUT	Equipment Under Test
<i>f</i>	Frequency
FCC	Federal Communications Commission
GRP	Ground Reference Plane
H	Magnetic Field
HCP	Horizontal Coupling Plane
Hz	Hertz
IEC	International Electrotechnical Commission
kHz	Kilohertz
kPa	Kilopascal
kV	Kilovolt
LISN	Line Impedance Stabilization Network
MHz	Megahertz
μH	Microhenry
μ	Microfarad
μs	Microseconds
PRF	Pulse Repetition Frequency
RF	Radio Frequency
RMS	Root-Mean-Square
TWT	Traveling Wave Tube
V/m	Volts per meter
VCP	Vertical Coupling Plane

I. Executive Summary

A. Purpose of Test

An EMC evaluation was performed to determine compliance of the Firetide, Inc. 7010(W), with the requirements of Part 15, §15.407. All references are to the most current version of Title 47 of the Code of Federal Regulations in effect. In accordance with §2.1033, the following data is presented in support of the Certification of the 7010(W). Firetide, Inc. should retain a copy of this document which should be kept on file for at least two years after the manufacturing of the 7010(W), has been **permanently** discontinued.

B. Executive Summary

The following tests were conducted on a sample of the equipment for the purpose of demonstrating compliance with Part 15, §15.407, in accordance with Firetide, Inc., purchase order number PO-3987. All tests were conducted using measurement procedure ANSI C63.4-2014 and [ANSI C63.10-2013](#).

FCC Reference	Description	Results
§15.203	Antenna Requirement	Compliant
§15.403(i)	26dB Occupied Bandwidth	Compliant
§15.407 (a)(1)	Maximum Conducted Output Power	Compliant
§15.407 (a)(1)	Maximum Power Spectral Density	Compliant
§15.407 (b)(1)& (6 - 7)	Undesirable Emissions	Compliant
§15.407(b)(6)	Conducted Emission Limits	Compliant
§15.407(c)	Automatic Discontinue of Transmitter	Not Applicable
§15.407(f)	RF Exposure	Compliant
§15.407(g)	Frequency Stability	Not Applicable

Table 1. Executive Summary of EMC Part 15.407 Compliance Testing

II. Equipment Configuration

A. Overview

MET Laboratories, Inc. was contracted by Firetide, Inc. to perform testing on the 7010(W), under Firetide, Inc.'s purchase order number PO-3987.

This document describes the test setups, test methods, required test equipment, and the test limit criteria used to perform compliance testing of the Firetide, Inc. 7010(W).

The results obtained relate only to the item(s) tested.

Model(s) Tested:	7010(W)	
Model(s) Covered:	7010(W)	
EUT Specifications:	Primary Power: 115VAC 60Hz	
	FCC ID: REP-7100-W	
	Type of Modulations:	BPSK, DQPSK, CCK & QAM
	Equipment Code:	NII
	Max. RF Output Power:	11n 40MHz @5230MHz: 26.77 dBm
	EUT Frequency Ranges:	5180MHz – 5240MHz
Analysis:	The results obtained relate only to the item(s) tested.	
Environmental Test Conditions:	Temperature: 15-35° C	
	Relative Humidity: 30-60%	
	Barometric Pressure: 860-1060 mbar	
Type of Filing:	Original	
Evaluated by:	Jun Qi	
Report Date(s):	February 20, 2017	

Table 2. EUT Summary

B. References

CFR 47, Part 15, Subpart E	Unlicensed National Information Infrastructure Devices (UNII)
ANSI C63.4:2014	Methods and Measurements of Radio-Noise Emissions from Low-Voltage Electrical And Electronic Equipment in the Range of 9 kHz to 40 GHz
ISO/IEC 17025:2005	General Requirements for the Competence of Testing and Calibration Laboratories
ANSI C63.10-2013	American National Standard for Testing Unlicensed Wireless Devices
789033 D02 General UNII Test Procedures New Rules v01	Guidelines for Compliance Testing of Unlicensed National Information Infrastructure (U-NII) Devices Part 15, Subpart E

Table 3. References

C. Test Site

All testing was performed at MET Laboratories, Inc., 6162 Belick St., Santa Clara, CA 95054. All equipment used in making physical determinations is accurate and bears recent traceability to the National Institute of Standards and Technology.

Radiated Emissions measurements were performed in a 5 meter semi-anechoic chamber (equivalent to an Open Area Test Site). In accordance with §2.948(a)(3), a complete site description is contained at MET Laboratories.

D. Description of Test Sample

The Firetide, Inc. 7010(W), Equipment Under Test (EUT), is A Firetide Mesh Network, which is composed of two or more Mesh Nodes, gives you the convenience of a wired- Ethernet switch combined with the deployment flexibility of wireless technology. Each Mesh Node in the network can accept a wired Ethernet connection. That connection's Ethernet data is sent wirelessly to another Mesh Node. If the receiving Mesh Node is connected to the wired destination for the data packet, the Node routes that packet to its Ethernet connection. If it is not the final destination, the packet is forwarded wirelessly to the next Mesh Node and ultimately to its final destination. Depending on the network topology, a Mesh Node can be set up to operate as a point to point device (in which directional antennas would be used) or as a point to multipoint device (in which a combination of omnidirectional and directional antennas would be used). The Radio technology incorporated into the Mesh Node is based on the 802.11a/b/g/n standard. The Radio can be configured to operate in standard 802.11g mode or 802.11n mode, referred to as MIMO.

The HotPort Node is housed in a weatherized, cast aluminum enclosure. External antennas connect to the four type N connectors (two per radio 2x2), two on each side of the enclosure.

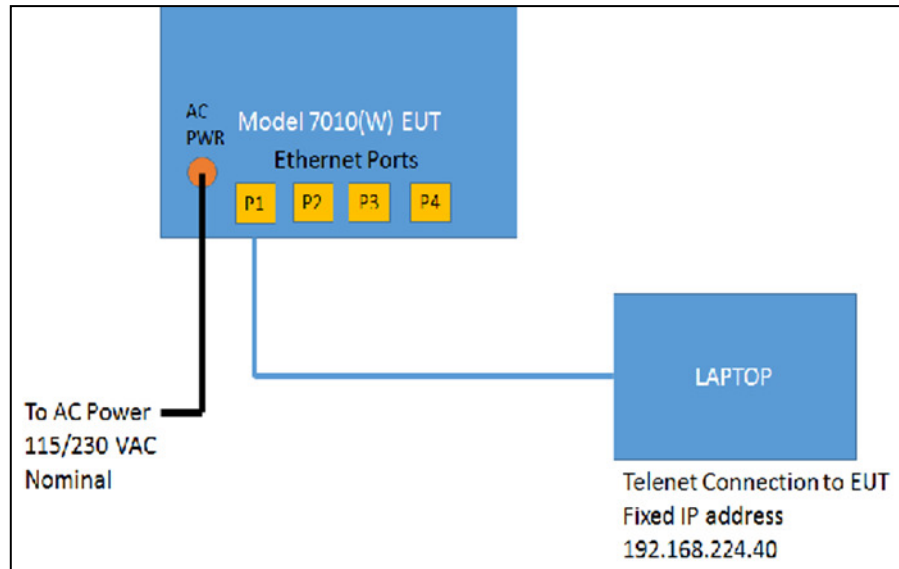

Figure 1. Block Diagram of Test Configuration

E. Equipment Configuration

The EUT was set up as outlined in Figure 1, Block Diagram of Test Setup. All cards, racks, etc., incorporated as part of the EUT is included in the following list.

Ref. ID	Slot #	Name / Description	Model Number	Part Number	Serial Number	Rev. #
1		HOTPORT Out Door Mesh Node	7010(W)	7010(W)		1.0

Table 4. Equipment Configuration

F. Support Equipment

Support equipment necessary for the operation and testing of the EUT is included in the following list.

Ref. ID	Name / Description	Manufacturer	Model Number	*Customer Supplied Calibration Data
1	5.125 to 6.1G,3xN, 19dBi Panel Antenna	Firetide	AP-20-050-MIMO-19	N/A
2	4.9 to 6.1 GHZ3xN, 16dBi Sector	Firetide	AS90-050-MIMO-16T	N/A
3	5.15 to 5.85G,3 Port, 8dBi Omini	Firetide	AO-050-MIMO-9	N/A
4	2.3 to 2.7G,2xN, 13dBi Panel	Firetide	AS90-024-MIMO-13	N/A
5	2.4 to 2.5G,3 Port, 9dBi ,Omini	Firetide	AO-024-MIMO-8	N/A
6	5G, 5dBi Omini (used for DFS)	WHA Yu	C812510010-A	N/A
7	5G, 5dBi Omini(used for DFS)	WHA Yu	C812510012-A	N/A

The 'Customer Supplied Calibration Data' column will be marked as either not applicable, not available, or will contain the calibration date supplied by the customer.

Table 5. Support Equipment

G. Ports and Cabling Information

Ref. ID	Port name on EUT	Cable Description or reason for no cable	Qty	Length as tested (m)	Shielded? (Y/N)	Termination Box ID & Port Name
1	Antenna Ports, Radio1: Ant1, Ant2 Radio2: Ant1, Ant2	CB-C-015- N(LMR400)	4	1.5Meter	Yes	Antenna Ports
2	Power Input Port: AC	Power cord, 3 conductor, 18 awg	1		Yes	AC: Power Input Port (115v/50hz)
3	Port1 ... Port4 (P1...P4)	CAT 5E Ethernet cable	1	2 Meter	N	Port1 ... Port4

Table 6. Ports and Cabling Information

H. Mode of Operation

Once the AC power/POE Power is applied LED indicates to mention that the 7010(W) unit is powered on properly. . Proper IP address should be set in the PC prior to the Ethernet cable connection. The Ethernet connectivity needs to be made by connecting an Ethernet cable. Once the connection is established, you can verify this in the PC's LAN connectivity status. Proper IP address should be set in the PC prior to the Ethernet cable connection.

I. Method of Monitoring EUT Operation

Electrical Indication: Power and Status LED's on the front panel To verify whether the EUT is power ON , if the EUT is ON the Power LED will glow Green.

Status LED Glows when the firmware is up. When the unit meshes with another unit using single radio configuration Radio1 LED will glow and when the unit meshes with another unit with dual radio configuration both Radio 1 and Radio 2 LED will glow. With the Ethernet cable connected to PC or Laptop Ping the EUT with the IP address 192.168.224.xxx (150) for 7010(W).

J. Modifications

a) Modifications to EUT

No modifications were made to the EUT.

b) Modifications to Test Standard

No modifications were made to the test standard.

K. Disposition of EUT

The test sample including all support equipment submitted to the Electro-Magnetic Compatibility Lab for testing was returned to Firetide, Inc. upon completion of testing.

III. Electromagnetic Compatibility Criteria for Intentional Radiators

Electromagnetic Compatibility Criteria for Intentional Radiators

§ 15.203 Antenna Requirement

Test Requirement: § 15.203: An intentional radiator shall be designed to ensure that no antenna other than that furnished by the responsible party shall be used with the device. The use of a permanently attached antenna or of an antenna that uses a unique coupling to the intentional radiator shall be considered sufficient to comply with the provisions of this section. The manufacturer may design the unit so that a broken antenna can be replaced by the user, but the use of a standard antenna jack or electrical connector is prohibited.

The structure and application of the EUT were analyzed to determine compliance with Section 15.203 of the Rules. Section 15.203 states that the subject device must meet at least one of the following criteria:

- a.) Antenna must be permanently attached to the unit.
- b.) Antenna must use a unique type of connector to attach to the EUT.
- c.) Unit must be professionally installed. Installer shall be responsible for verifying that the correct antenna is employed with the unit.

Results: The EUT as tested is compliant the criteria C of §15.203.

Unit must be professionally installed. Installer shall be responsible for verifying that the correct antenna is employed with the unit.

Test Engineer(s): Jun Qi

Test Date(s): November 30, 2016

Electromagnetic Compatibility Criteria for Intentional Radiators

§ 15. 403(i) 26dB Bandwidth

Test Requirements: § 15.403(i): For purposes of this subpart the emission bandwidth shall be determined by measuring the width of the signal between two points, one below the carrier center frequency and one above the carrier center frequency, that are 26 dB down relative to the maximum level of the modulated carrier. Determination of the emissions bandwidth is based on the use of measurement instrumentation employing a peak detector function with an instrument resolution bandwidth approximately equal to 1.0 percent of the emission bandwidth of the device under measurement.

Test Procedure: The transmitter was set to low, mid, and high operating frequencies at the highest output power and connected to the spectrum analyzer through an attenuator. The bandwidth of the fundamental frequency was measured with the spectrum analyzer using a RBW approximately equal to 1% of the total emission bandwidth, VBW > RBW. The 26 dB Bandwidth was measured and recorded.

Test Results The 26 dB Bandwidth was compliant with the requirements of this section.

No anomalies detected.

Test Engineer(s): Saeed Kabirsalmani

Test Date(s): November 18, 2016

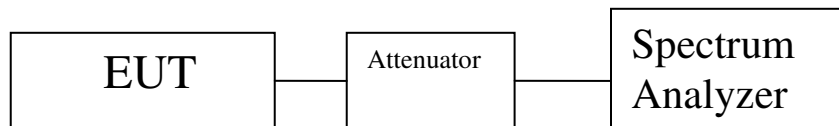

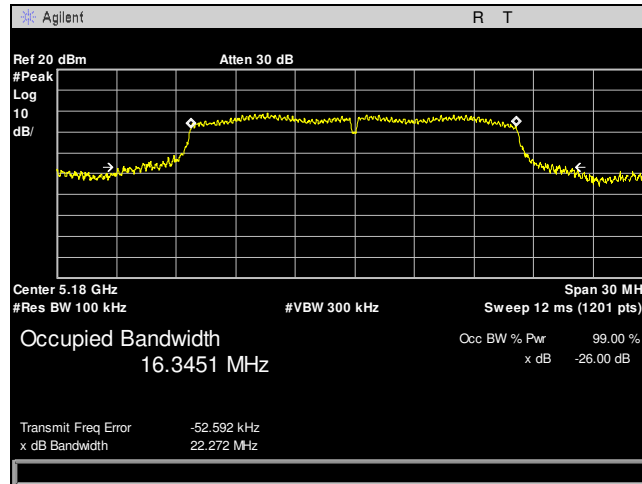

Plot 1. 26 dB Occupied Bandwidth, 802.11a, 20MHz, Ch. 5180 MHz, R11

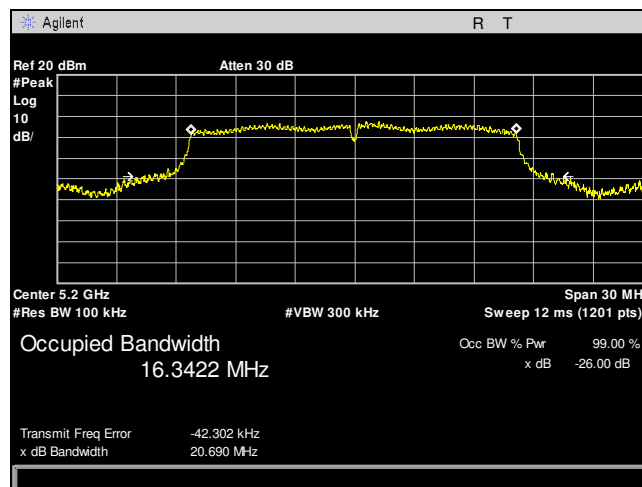

Plot 2. 26 dB Bandwidth, 802.11a, 20MHz, Ch. 5200 MHz, R11

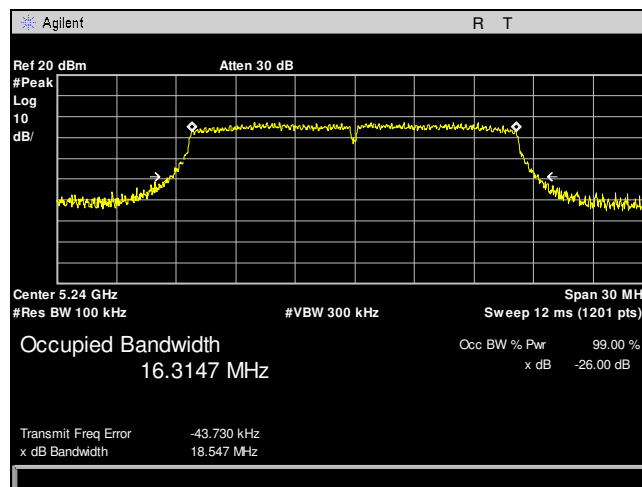

Plot 3. 26 dB Bandwidth, 802.11a, 20MHz, Ch. 5240MHz, R11

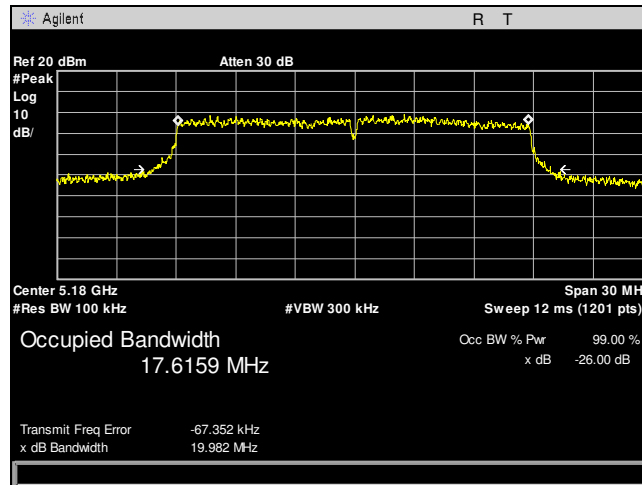

Plot 4. 26 dB Bandwidth, 802.11n, 20 MHz, Ch. 5180 MHz, R11

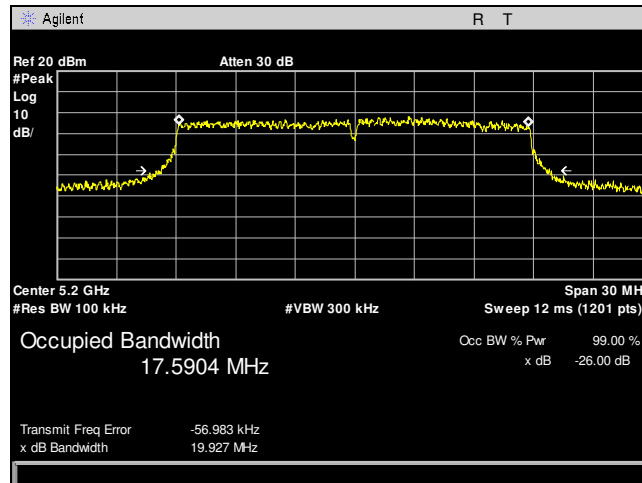

Plot 5. 26 dB Bandwidth, 802.1n, 20 MHz, 5200 MHz, R11

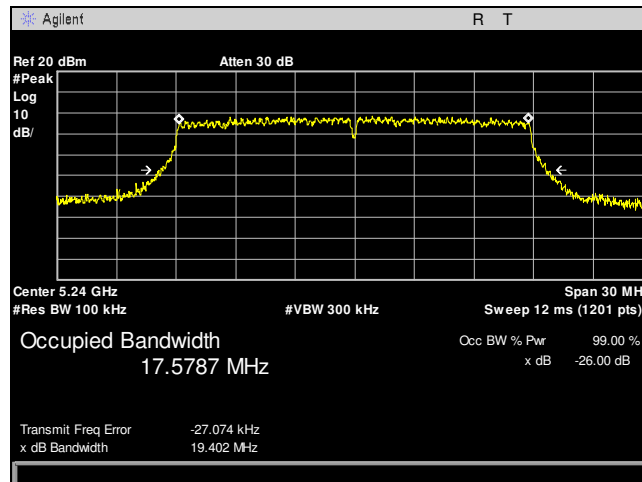

Plot 6. 26 dB Bandwidth, 802.11n, 20 MHz, 5240MHz, R11

Electromagnetic Compatibility Criteria for Intentional Radiators

§15.407(a)(1) Maximum Conducted Output Power

Test Requirements: §15.407(a)(1)(i): For an outdoor access point operating in the band 5.15-5.25 GHz, the maximum conducted output power over the frequency band of operation shall not exceed 1 W provided the maximum antenna gain does not exceed 6 dBi.

If transmitting antennas of directional gain greater than 6 dBi are used, both the maximum conducted output power and the maximum power spectral density shall be reduced by the amount in dB that the directional gain of the antenna exceeds 6 dBi.

§15.407(a)(1)(ii): For an indoor access point operating in the band 5.15-5.25 GHz, the maximum conducted output power over the frequency band of operation shall not exceed 1 W provided the maximum antenna gain does not exceed 6 dBi.

If transmitting antennas of directional gain greater than 6 dBi are used, both the maximum conducted output power and the maximum power spectral density shall be reduced by the amount in dB that the directional gain of the antenna exceeds 6 dBi.

§15.407(a)(1)(iii): For fixed point-to-point access points operating in the band 5.15-5.25 GHz, the maximum conducted output power over the frequency band of operation shall not exceed 1 W.

Fixed point-to-point U-NII devices may employ antennas with directional gain up to 23 dBi without any corresponding reduction in the maximum conducted output power or maximum power spectral density. For fixed point-to-point transmitters that employ a directional antenna gain greater than 23 dBi, a 1 dB reduction in maximum conducted output power and maximum power spectral density is required for each 1 dB of antenna gain in excess of 23 dBi.

§15.407(a)(1)(iv): For mobile and portable client devices in the 5.15-5.25 GHz band, the maximum conducted output power over the frequency band of operation shall not exceed 250 mW provided the maximum antenna gain does not exceed 6 dBi.

If transmitting antennas of directional gain greater than 6 dBi are used, both the maximum conducted output power and the maximum power spectral density shall be reduced by the amount in dB that the directional gain of the antenna exceeds 6 dBi.

Test Procedure: The EUT was connected to a spectrum analyzer through a cable and attenuator. Measurements were taken with the EUT set to transmit continuously on its low, mid, and high channels. Its power was measured according to measurement method SA-1, as described in 789033 D02 General UNII Test Procedures v01 and KDB 662911 D01 Multiple Transmitter Output v02r01.

Limit calculation: $\text{limit} = 30 - (G_a - 6)$

Limit Power_{19dBi} = $30 - (19 - 6) = 17$ dBm

Limit Power_{16dBi} = $30 - (16 - 6) = 20$ dBm

Limit Power_{9dBi} = $30 - (9 - 6) = 27$ dBm

Test Results: The EUT as tested is compliant with the requirements of this section.

No anomalies detected..

Test Engineer(s): Saeed KabirSalmani

Test Date(s): November 17, 2016

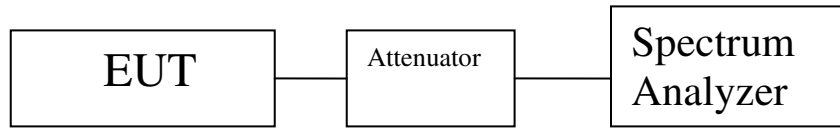

Peak Conducted Output Power					
	Channel	Frequency (MHz)	Measured Peak Power (dBm)		
Gain			19dBi	16dBi	9dBi
802.11a 20MHz Port R11	Low	5180	6.19	9.37	17.49
	Mid	5200	6.69	9.99	17.74
	High	5240	7.53	10.35	18.51
802.11a 20 MHz Port R12	Low	5180	6.52	10.12	18.12
	Mid	5200	7.71	9.91	17.18
	High	5240	7.19	9.95	17.98
802.11a 20MHz Port R21	Low	5180	8.33	9.75	18.3
	Mid	5200	7.89	9.9	17.9
	High	5240	7.93	9.33	18.77
802.11a 20 MHz Port R22	Low	5180	7.13	12.12	19.31
	Mid	5200	6.52	11.24	19.48
	High	5240	6.42	11.36	19.09
802.11n 20MHz Port R11	Low	5180	6.58	9.86	18.18
	Mid	5200	6.82	10	17.72
	High	5240	7.39	11.48	18.24
802.11n 20 MHz Port R12	Low	5180	6.49	11.19	18.66
	Mid	5200	7.63	10.75	18.02
	High	5240	7.70	11.36	18.9
802.11n 20MHz Port R21	Low	5180	8.26	10.8	19.05
	Mid	5200	7.84	10.01	18.1
	High	5240	7.81	10.37	18.91
802.11n 20 MHz Port R22	Low	5180	7.15	11.71	18.81
	Mid	5200	6.65	11.44	19.1
	High	5240	7.04	11.15	18.6

Table 8. Maximum Conducted Output Power, UNII 1 20 MHz, Peak Conducted Output Power

Summed Peak Conducted Output Power					
	Channel	Frequency (MHz)	Measured Peak Power (dBm)		
Gain			19dBi	16dBi	9dBi
802.11a 20 MHz Summed	Low	5180	13.14	16.50	24.38
	Mid	5200	13.26	16.32	24.18
	High	5240	13.32	16.33	24.63
802.11n 20 MHz Summed	Low	5180	13.20	16.96	24.71
	Mid	5200	13.29	16.61	24.29
	High	5240	13.52	17.13	24.69
Limit			17	20	27

Table 9. Maximum Conducted Output Power, UNII 1 20 MHz Summed Peak Conducted Output Power

Peak Conducted Output Power					
	Channel	Frequency (MHz)	Measured Peak Power (dBm)		
Gain			19dBi	16dBi	9dBi
802.11n 20MHz Port R11	Low	5190	10.02	13.38	20.42
	High	5230	9.13	13.67	20.7
802.11n 20 MHz Port R12	Low	5190	10.56	13.69	20.56
	High	5230	10.54	13.46	20.87
802.11n 20MHz Port R21	Low	5190	10.80	13.85	20.38
	High	5230	10.51	13.71	20.76
802.11n 20 MHz Port R22	Low	5190	10.17	13.14	20.02
	High	5230	10.47	13.53	20.68

Table 10. Maximum Conducted Power, UNII 1 40 MHz, Peak Conducted Output Power

Summed Peak Conducted Output Power					
	Channel	Frequency (MHz)	Measured Peak Power (dBm)		
Gain			19dBi	16dBi	9dBi
802.11n 20 MHz Summed	Low	5190	16.42	19.54	26.37
	High	5230	16.22	19.61	26.77
Limit			17	20	27

Table 11. Maximum Conducted Power, UNII 40 MHz, Summed Peak Conducted Output Power

EIRP at 30 degree elevation above Horizon for 19 dBi antenna

Peak radiation gain in the direction of Sky at elevation angle above 30 degree as measured from the Horizon for 7010(w) unit is less than 0.5 dBi based upon provided 19 dBi antenna spec sheet. When installed the 5GHz antenna orientation will be vertically inverted to provide Omni directional Beam pattern towards the ground plane. Refer to Antenna Spec sheet for radiation beam pattern of 7010(w) unit.

EIRP at 30 degree Elevation above Horizon

- Maximum sum of conducted power in UNII-1 Band from all 4 antenna chain: 16.42dBm
- Peak antenna gain above 30 degree elevation from Horizon as per antenna spec sheet: 19 - 18.5 = 0.5dBi
- Peak EIRP above 30 degree elevation from Horizon: Maximum Conducted Power (dBm)+ Peak Antenna Gain above 30 degree elevation from Horizon (dBi) = 16.4+0.5= 16.9dBm
- Margin from FCC 15.407 limit: 21dBm-16.9dBm = 4.1 dB

EIRP at 30 degree elevation above Horizon for 16 dBi antenna

Peak radiation gain in the direction of Sky at elevation angle above 30 degree as measured from the Horizon for 7010(w) unit is less than -4 dBi based upon provided 16 dBi antenna spec sheet. When installed the 5GHz antenna orientation will be vertically inverted to provide Omni directional Beam pattern towards the ground plane. Refer to Antenna Spec sheet for radiation beam pattern of 7010(w) unit.

EIRP at 30 degree Elevation above Horizon

- Maximum sum of conducted power in UNII-1 Band from all 4 antenna chain: 21.54dBm
- Peak antenna gain above 30 degree elevation from Horizon as per antenna spec sheet: $16 - 18 = -2$ dBi
- Peak EIRP above 30 degree elevation from Horizon: Maximum Conducted Power (dBm)+ Peak Antenna Gain above 30 degree elevation from Horizon (dBi) = $19.61 - 2 = 17.61$ dBm
- Margin from FCC 15.407 limit: $21\text{dBm} - 17.61\text{dBm} = 3.39$ dB

EIRP at 30 degree elevation above Horizon for 9 dBi antenna

Peak radiation gain in the direction of Sky at elevation angle above 30 degree as measured from the Horizon for 7010(w) unit is less than -4 dBi based upon provided 19 dBi antenna spec sheet. When installed the 5GHz antenna orientation will be vertically inverted to provide Omni directional Beam pattern towards the ground plane. Refer to Antenna Spec sheet for radiation beam pattern of 7010(w) unit.

EIRP at 30 degree Elevation above Horizon

- Maximum sum of conducted power in UNII-1 Band from all 4 antenna chain: 26.77dBm
- Peak antenna gain above 30 degree elevation from Horizon as per antenna spec sheet: $9 - 15 = -6$ dBi
- Peak EIRP above 30 degree elevation from Horizon: Maximum Conducted Power (dBm)+ Peak Antenna Gain above 30 degree elevation from Horizon (dBi)= $26.77 - 6 = 20.77$ dBm
- Margin from FCC 15.407 limit: $21\text{dBm} - 20.77\text{dBm} = 0.23$ dB

Electromagnetic Compatibility Criteria for Intentional Radiators

§15.407(a)(1) Maximum Power Spectral Density

Test Requirements:

§15.407(a)(1)(i): In addition, the maximum power spectral density shall not exceed 17 dBm in any 1 megahertz band. If transmitting antennas of directional gain greater than 6 dBi are used, both the maximum conducted output power and the maximum power spectral density shall be reduced by the amount in dB that the directional gain of the antenna exceeds 6 dBi.

§15.407(a)(1)(ii): In addition, the maximum power spectral density shall not exceed 17 dBm in any 1 megahertz band. If transmitting antennas of directional gain greater than 6 dBi are used, both the maximum conducted output power and the maximum power spectral density shall be reduced by the amount in dB that the directional gain of the antenna exceeds 6 dBi..

§15.407(a)(1)(iii): In addition, the maximum power spectral density shall not exceed 17 dBm in any 1 megahertz band. Fixed point-to-point U-NII devices may employ antennas with directional gain up to 23 dBi without any corresponding reduction in the maximum conducted output power or maximum power spectral density. For fixed point-to-point transmitters that employ a directional antenna gain greater than 23 dBi, a 1 dB reduction in maximum conducted output power and maximum power spectral density is required for each 1 dB of antenna gain in excess of 23 dBi.

§15.407(a)(1)(iv): In addition, the maximum power spectral density shall not exceed 11 dBm in any 1 megahertz band. If transmitting antennas of directional gain greater than 6 dBi are used, both the maximum conducted output power and the maximum power spectral density shall be reduced by the amount in dB that the directional gain of the antenna exceeds 6 dBi.

Test Procedure:

The EUT was connected to a spectrum analyzer through a cable and attenuator. Measurements were taken with the EUT set to transmit continuously on its low, mid, and high channels. Its power was measured according KDB 789033 D02 General UNII Test Procedures v01 and KDB 662911 D01 Multiple Transmitter Output v02r01.

Limit calculation: $\text{limit} = 17 - (\text{Ga} - 6)$
Limit PSD_{19dBi} = $17 - (19 - 6) = 4 \text{ dBm}$
Limit PSD_{16dBi} = $17 - (16 - 6) = 7 \text{ dBm}$
Limit PSD_{9dBi} = $17 - (9 - 6) = 14 \text{ dBm}$

Test Results:

The EUT as tested is compliant with the requirements of this section.

No anomalies detected..

Test Engineer(s):

Saeed Kabirsalmani

Test Date(s):

November 17, 2016

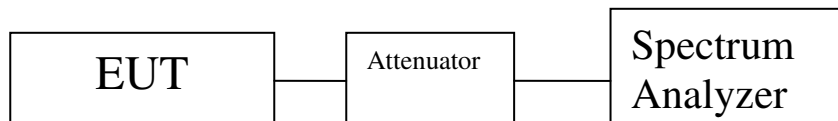

PSD					
	Channel	Frequency (MHz)	Measured PSD(dBm)		
Gain			19dBi	16dBi	9dBi
802.11a 20MHz Port R11	Low	5180	-3.91	0.52	7.24
	Mid	5200	-3.69	0.99	7.37
	High	5240	-4.27	0.71	7.66
802.11a 20 MHz Port R12	Low	5180	-3.75	0.996	7.38
	Mid	5200	-3.31	0.01	7.52
	High	5240	-3.48	0.54	7.54
802.11a 20MHz Port R21	Low	5180	-2.52	0.64	7.55
	Mid	5200	-2.70	0.08	7.68
	High	5240	-3.49	0.42	7.79
802.11a 20 MHz Port R22	Low	5180	-3.31	0.91	7.5
	Mid	5200	-4.16	0.91	7.57
	High	5240	-3.87	0.57	7.51
802.11n 20MHz Port R11	Low	5180	-4.19	0.88	7.08
	Mid	5200	-3.78	0.71	7.16
	High	5240	-3.52	0.27	7.43
802.11n 20 MHz Port R12	Low	5180	-4.72	0.9	7.5
	Mid	5200	-3.39	0.8	7.83
	High	5240	-3.95	0.8	7.87
802.11n 20MHz Port R21	Low	5180	-3.02	0.05	7.15
	Mid	5200	-3.36	0.07	7.17
	High	5240	-3.97	0.39	7.4
802.11n 20 MHz Port R22	Low	5180	-3.96	0.57	7.6
	Mid	5200	-3.95	0.56	7.21
	High	5240	-4.70	0.8	7.07

Table 12. Power Spectral Density, Peak Conducted 20MHz Output Power

Summed PSD					
	Channel	Frequency (MHz)	Measured PSD (dBm)		
Gain			19dBm	16dBm	9dBm
802.11a 20 MHz Summed	Low	5180	2.68	6.79	13.44
	Mid	5200	2.59	6.54	13.56
	High	5240	2.26	6.58	13.65
802.11n 20 MHz Summed	Low	5180	2.09	6.63	13.36
	Mid	5200	2.41	6.56	13.37
	High	5240	2.01	6.59	13.47
Limit			4	7	14

Table 13. Power Spectral Density, Summed Peak Conducted Output Power 20MHz

PSD					
	Channel	Frequency (MHz)	Measured PSD(dBm)		
Gain			19dBm	16dBm	9dBm
802.11n 20MHz Port R11	Low	5190	-4.65	0.81	6.41
	High	5230	-4.37	0.55	7.3
802.11n 20 MHz Port R12	Low	5190	-3.94	-0.6	6.71
	High	5230	-4.76	0.65	7.01
802.11n 20MHz Port R21	Low	5190	-4.67	1.1	6.4
	High	5230	-4.15	0.2	6.6
802.11n 20 MHz Port R22	Low	5190	-4.16	-0.49	5.54
	High	5230	-5.40	0.21	5.9

Table. Power Spectral Density, Peak Conducted 40MHz Output Power

Summed PSD					
	Channel	Frequency (MHz)	Measured PSD (dBm)		
Gain			19dBi	16dBi	9dBi
802.11n 20 MHz Summed	Low	5190	1.68	6.29	12.31
	High	5230	1.38	6.43	12.75
Limit			4	7	14

Table 14. Power Spectral Density, Summed Peak Conducted Output Power 40MHz

Electromagnetic Compatibility Criteria for Intentional Radiators

§15.407(b)(1) & (6 – 7) Undesirable Emissions

Test Requirements: § 15.407(b)(1): For transmitters operating in the 5.15-5.25 GHz band: all emissions outside of the 5.15-5.35 GHz band shall not exceed an EIRP of -27 dBm/MHz.

§ 15.407(b)(6): Unwanted emissions below 1 GHz must comply with the general field strength limits set forth in Section 15.209. Further, any U-NII devices using an AC power line are required to comply also with the conducted limits set forth in Section 15.207.

§ 15.407(b)(7): The provisions of Section 15.205 of this part apply to intentional radiators operating under this section.

Test Procedure: The EUT was placed on a non-conducting stand on a turntable in a chamber. To find the maximum emission the EUT was set to transmit on low, mid, and high channels. Additionally, the turntable was rotated 360 degrees, the EUT was oriented through its three orthogonal axes, and the receive antenna height was varied in order to maximize emissions.

For frequencies from 30 MHz to 1 GHz, measurements were first made using a peak detector with a 100 kHz resolution bandwidth. Emissions which exceeded the limits were re-measured using a quasi-peak detector with a 120 kHz resolution bandwidth.

Above 1 GHz, measurements were made pursuant the method described in FCC KDB 789033 D02 General UNII Test Procedure New Rules v01. The equation, $EIRP = E + 20 \log D - 104.8$ was used to convert field strength to EIRP (E = field strength (dB μ V/m) and D = Reference measurement distance).

For emissions above 1 GHz and in restricted bands, measurements of the field strength were made with a peak detector and an average detector and compared with the limits of 15.209.

Above 1 GHz, a notch filter(5150 MHz – 5250 MHz) is used for filter the fundamental signal.

As an alternative, according to FCC KDB 789033 D02 General UNII Test Procedure New Rules v01, all emissions above 1 GHz that comply with the peak and average limits of 15.209 satisfy the requirements of unwanted emissions in 15.407.

Test Results: For below 1 GHz, the EUT was compliant with the requirements of this section.

For above 1 GHz, the EUT was compliant with the requirements of this section.

Only noise floor was observed above 18GHz.

Test Engineer(s): Jun Qi

Test Date(s): November 30, 2016

Above 1 Ghz Undesirable Emissions

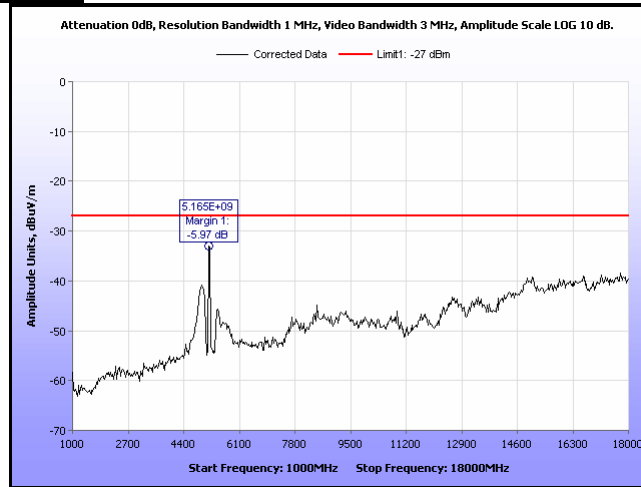

Plot 9. Radio Spurious Emission, 1 GHz - 18 GHz - 27 dBm, Bandwidth 20M, Ch. 5180M, a mode, TP15, 9dBi

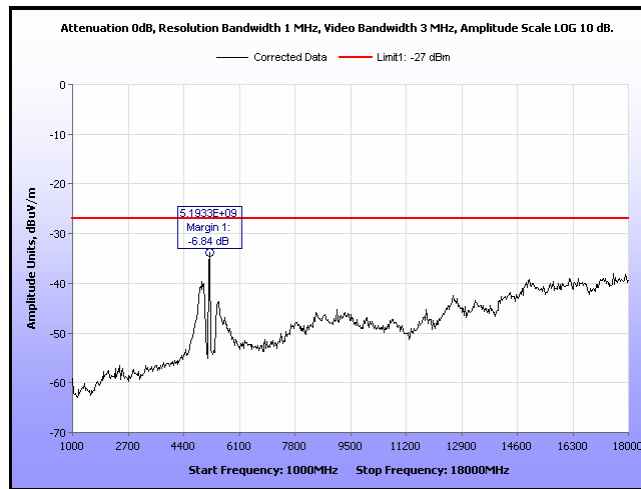

Plot 10. Radio Spurious Emission, 1 GHz - 18 GHz - 27 dBm, Bandwidth 20M, Ch. 5180M, n mode, TP15, 9 dBi

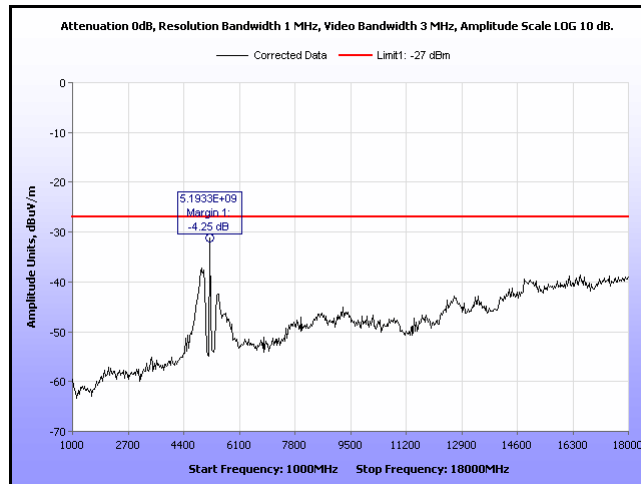

Plot 11. Radio Spurious Emission, 1 GHz - 18 GHz - 27 dBm, Bandwidth 20M, Ch. 5200M, a mode, TP22, 9 dBi

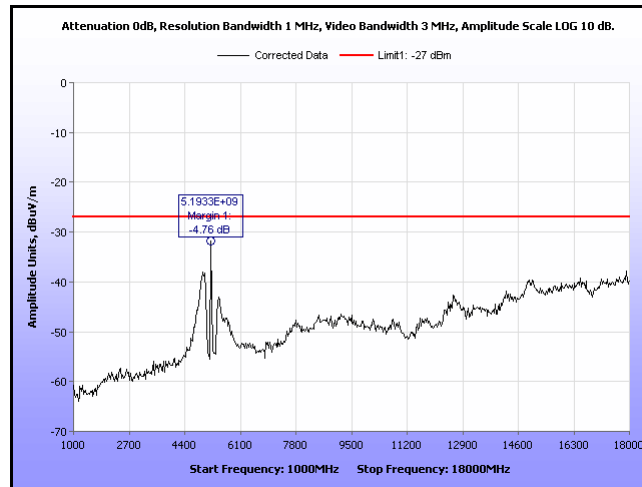

Plot 12. Radio Spurious Emission, 1 GHz - 18 GHz - 27 dBm, Bandwidth 20M, Ch. 5200M, n mode, TP21, 9 dBi

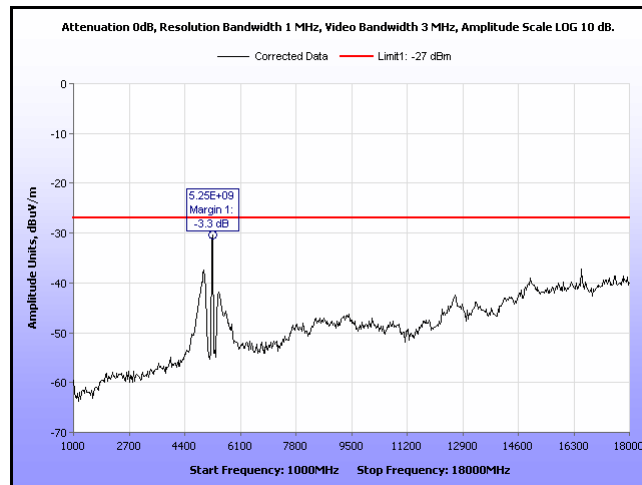

Plot 13. Radio Spurious Emission, 1 GHz - 18 GHz - 27 dBm, Bandwidth 20M, Ch. 5240M, a mode, TP22, 9 dBi

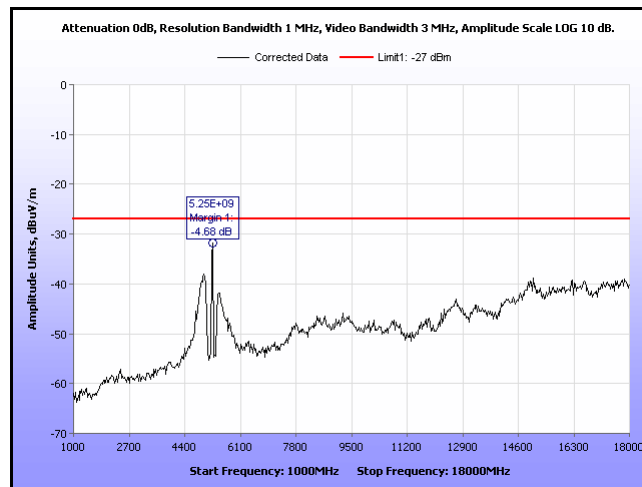

Plot 14. Radio Spurious Emission, 1 GHz - 18 GHz - 27 dBm, Bandwidth 20M, Ch. 5240M, n mode, TP22, 9 dBi

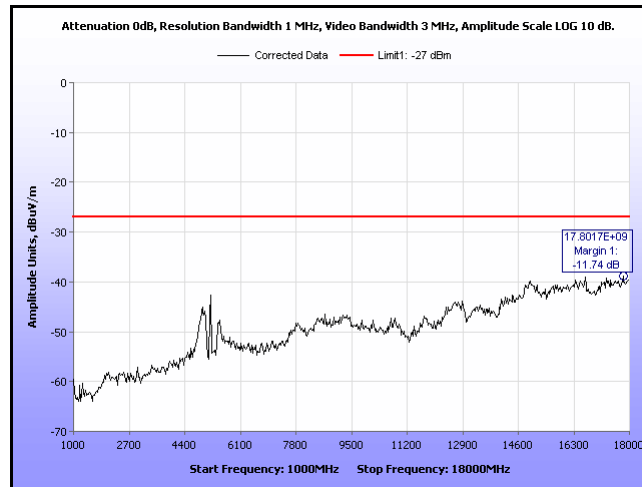

Plot 15. Radio Spurious Emission, 1 GHz - 18 GHz - 27 dBm, Bandwidth 40M, Ch. 5190M, n mode, TP9m 9 dBi

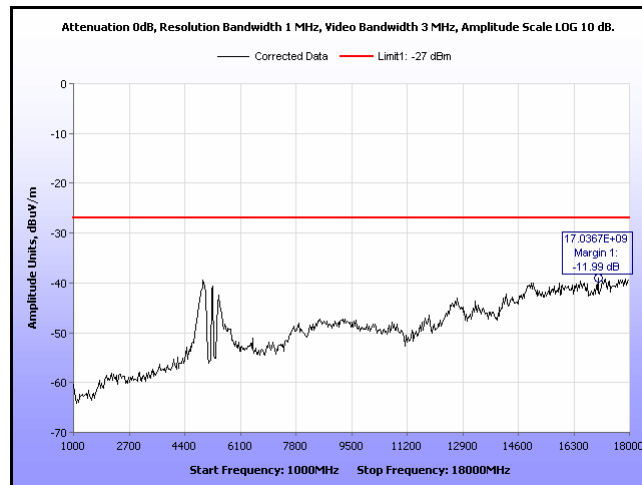

Plot 16. Radio Spurious Emission, 1 GHz - 18 GHz - 27 dBm, Bandwidth 40M, Ch. 5230M, n mode, TP15, 9 dBi

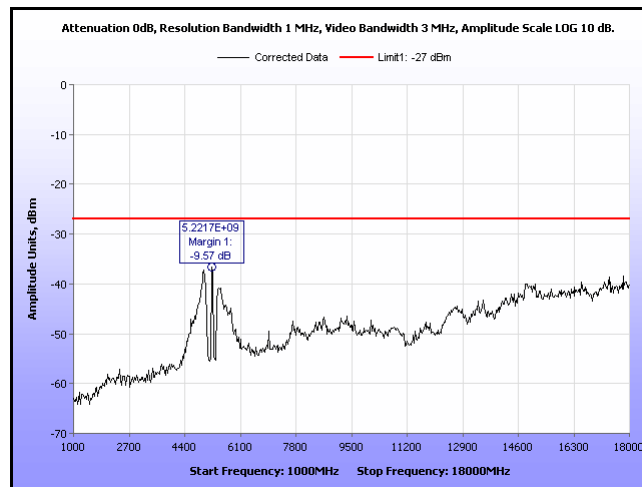

Plot 17. Radio Spurious Emission, 1 GHz - 18 GHz - 27 dBm, Bandwidth 40M, Ch. 5230M, n mode, TP18, 16 dBi

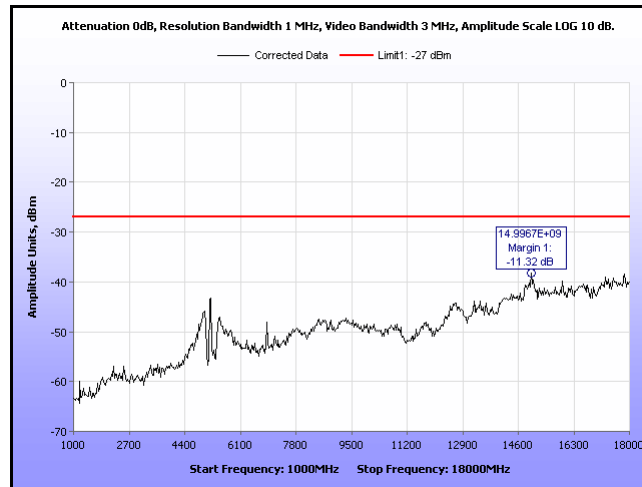

Plot 18. Radio Spurious Emission, 1 GHz - 18 GHz - 27 dBm, Bandwidth 40M, Ch. 5190M, n mode, TP7.5, 16 dBi

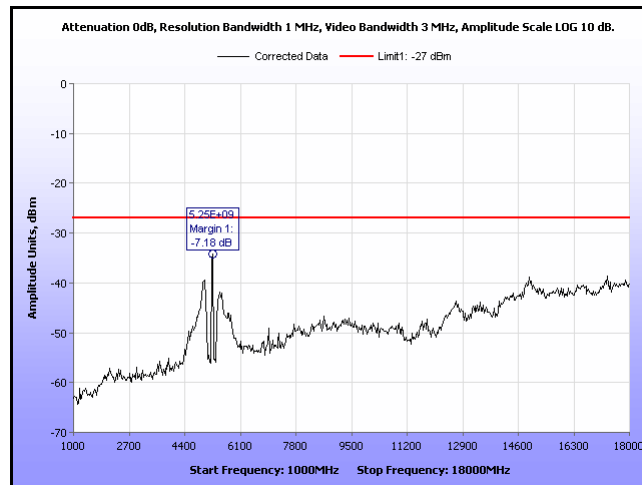

Plot 19. Radio Spurious Emission, 1 GHz - 18 GHz - 27 dBm, Bandwidth 20M, Ch. 5240M, n mode, TP17, 16 dBi

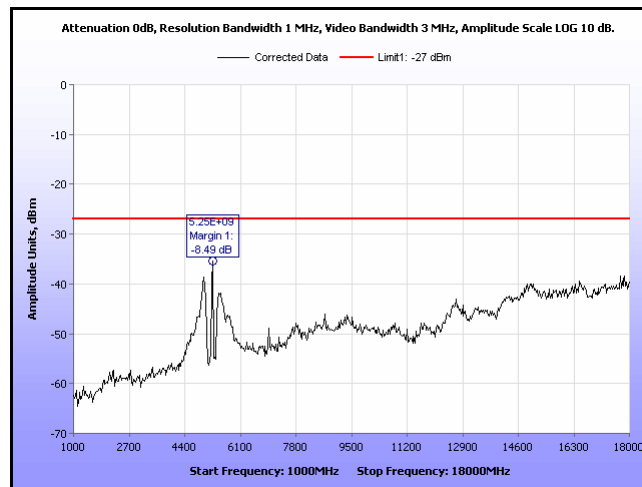

Plot 20. Radio Spurious Emission, 1 GHz - 18 GHz - 27 dBm, Bandwidth 20M, Ch. 5240M, a mode, TP17, 16 dBi

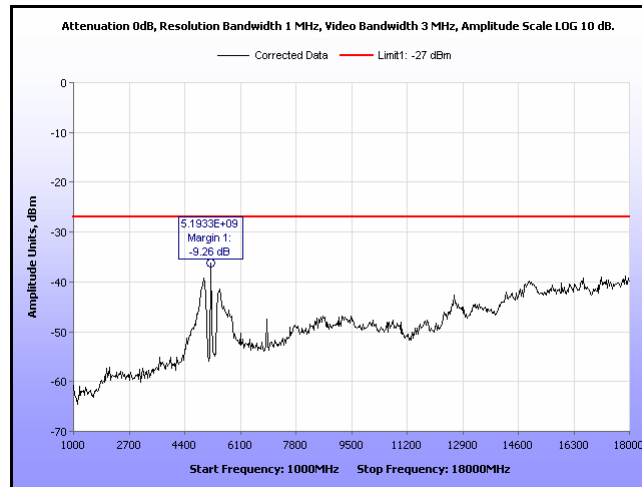

Plot 21. Radio Spurious Emission, 1 GHz - 18 GHz - 27 dBm, Bandwidth 20M, Ch. 5200M, n mode, TP17, 16 dBi

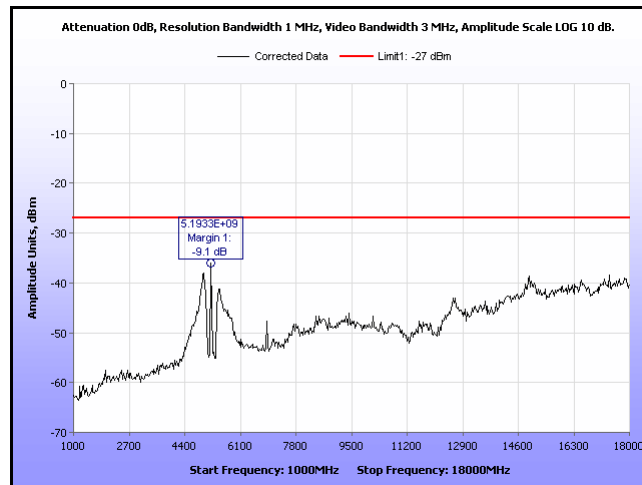

Plot 22. Radio Spurious Emission, 1 GHz - 18 GHz - 27 dBm, Bandwidth 20M, Ch. 5200M, a mode, TP17, 16 dBi

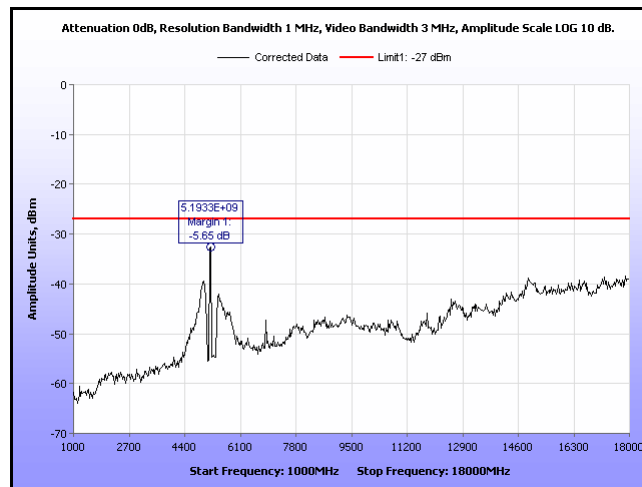

Plot 23. Radio Spurious Emission, 1 GHz - 18 GHz - 27 dBm, Bandwidth 20M, Ch. 5180M, n mode, TP15, 16 dBi

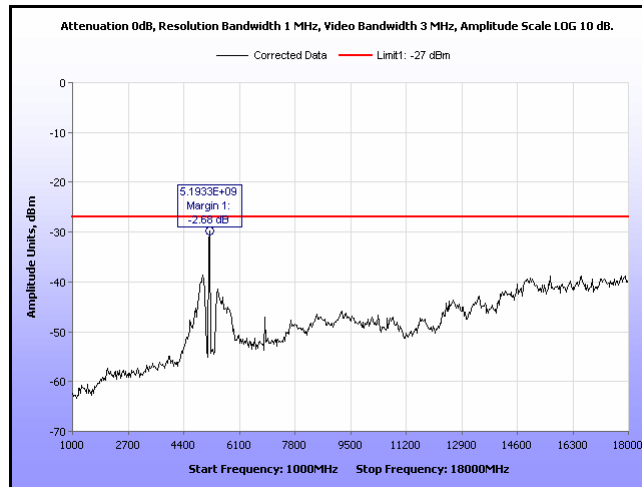

Plot 24. Radio Spurious Emission, 1 GHz - 18 GHz - 27 dBm, Bandwidth 20M, Ch. 5180M, a mode, TP17, 16 dBi

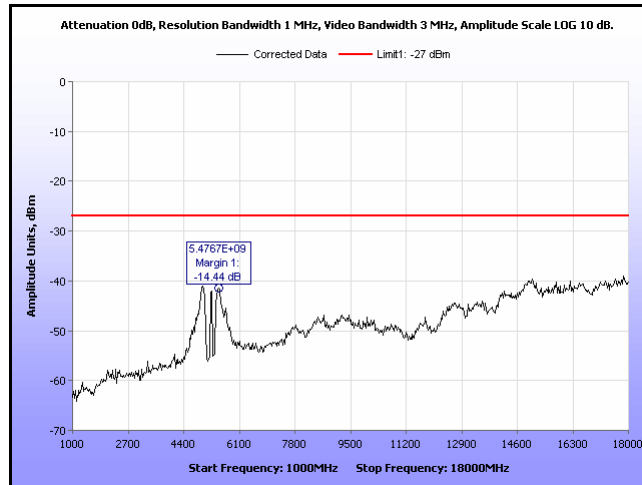

Plot 25. Radio Spurious Emission, 1 GHz - 18 GHz - 27 dBm, Bandwidth 40M, Ch. 5230M, n mode, TP11, 19 dBi

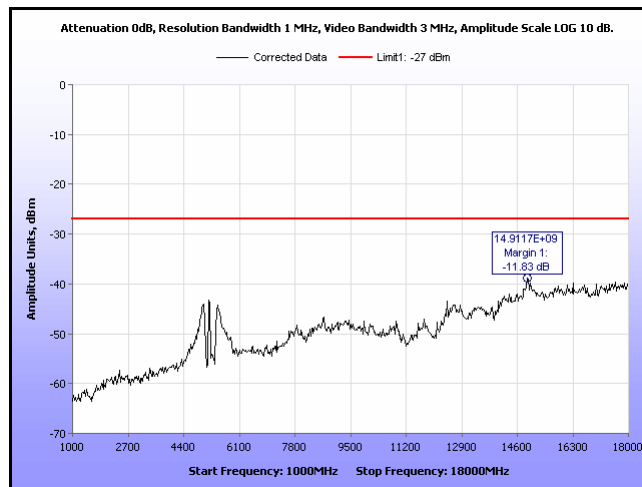

Plot 26. Radio Spurious Emission, 1 GHz - 18 GHz - 27 dBm, Bandwidth 40M, Ch. 5190M, n mode, TP6.5, 19 dBi

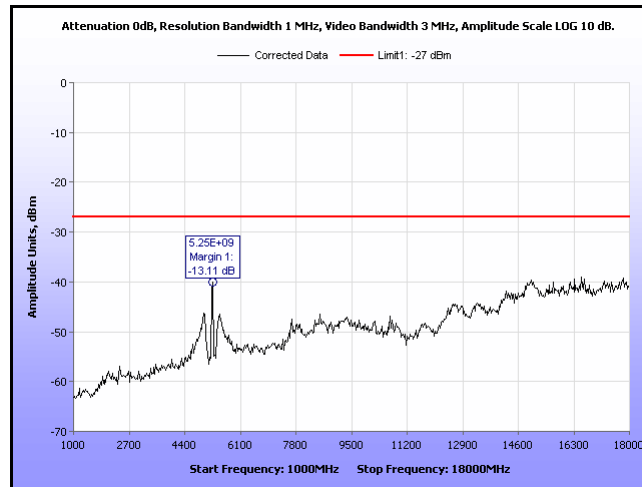

Plot 27. Radio Spurious Emission, 1 GHz - 18 GHz - 27 dBm, Bandwidth 20M, Ch. 5240M, n mode, TP9, 19 dBi

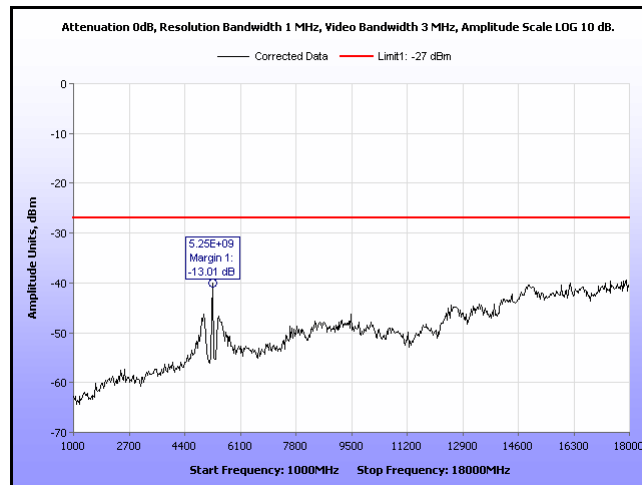

Plot 28. Radio Spurious Emission, 1 GHz - 18 GHz - 27 dBm, Bandwidth 20M, Ch. 5240M, a mode, TP9, 19 dBi



Plot 29. Radio Spurious Emission, 1 GHz - 18 GHz - 27 dBm, Bandwidth 20M, Ch. 5200M, n mode, TP9, 19 dBi

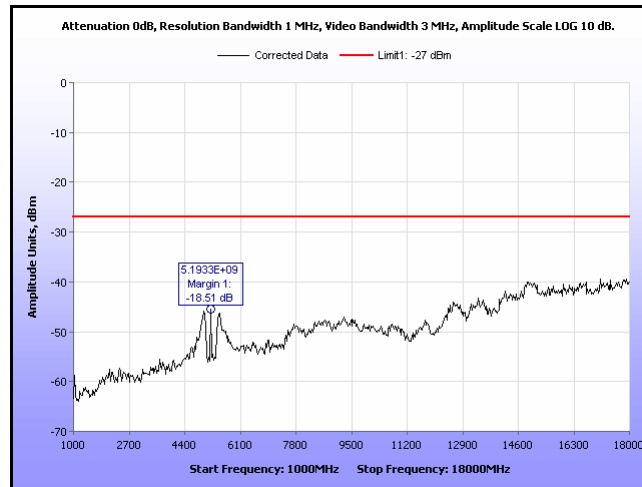

Plot 30. Radio Spurious Emission, 1 GHz - 18 GHz - 27 dBm, Bandwidth 20M, Ch. 5200M, a mode, TP9, 19 dBi

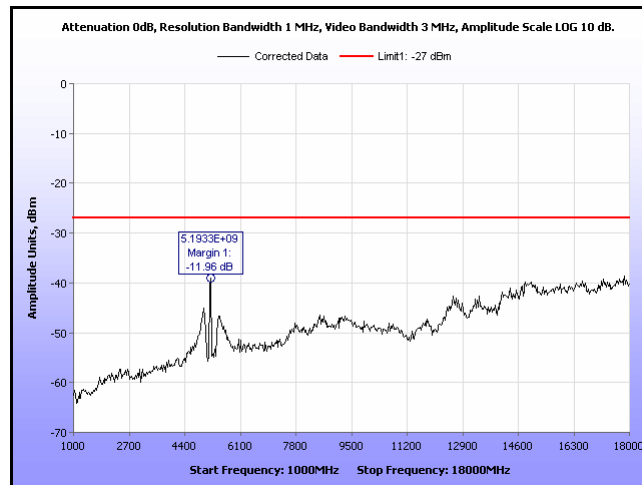

Plot 31. Radio Spurious Emission, 1 GHz - 18 GHz - 27 dBm, Bandwidth 20M, Ch. 5180M, n mode, TP9, 19 dBi

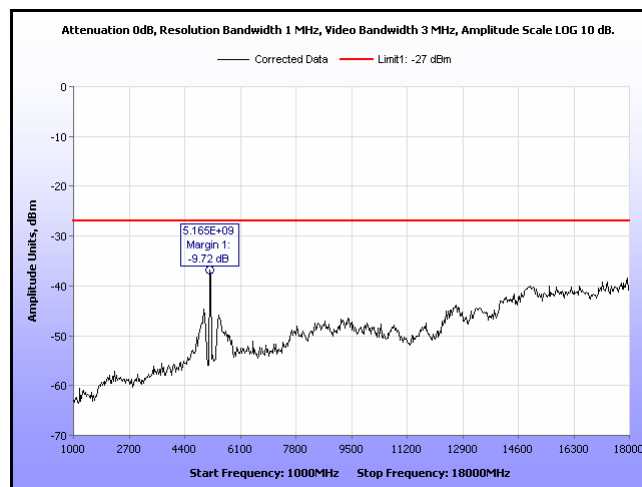

Plot 32. Radio Spurious Emission, 1 GHz - 18 GHz - 27 dBm, Bandwidth 20M, Ch. 5180M, a mode, TP9, 19 dBi

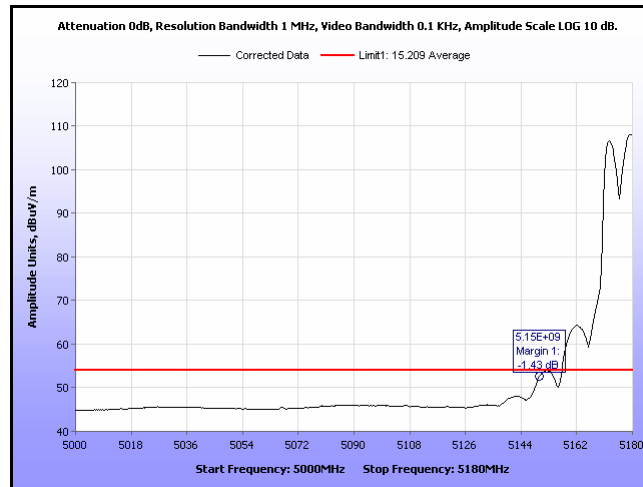

Plot 33. Restricted Band of Operation, 11a, 20MHz, 5180 MHz, OP 15 dB, Average 9 dBi

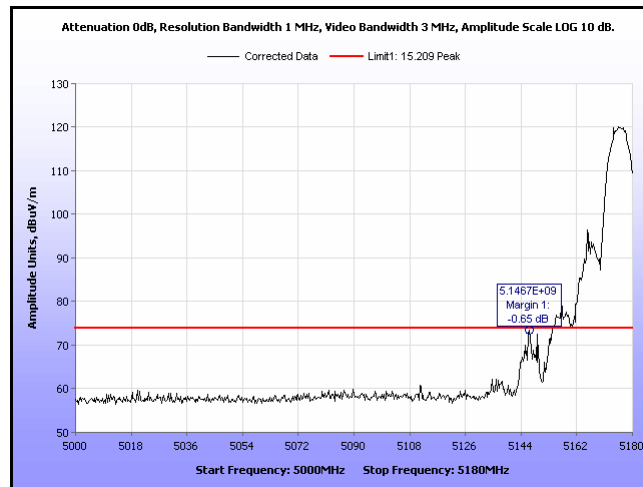

Plot 34. Restricted Band of Operation, 11a, 20MHz, 5180 MHz, OP 15 dB, Peak 9 dBi

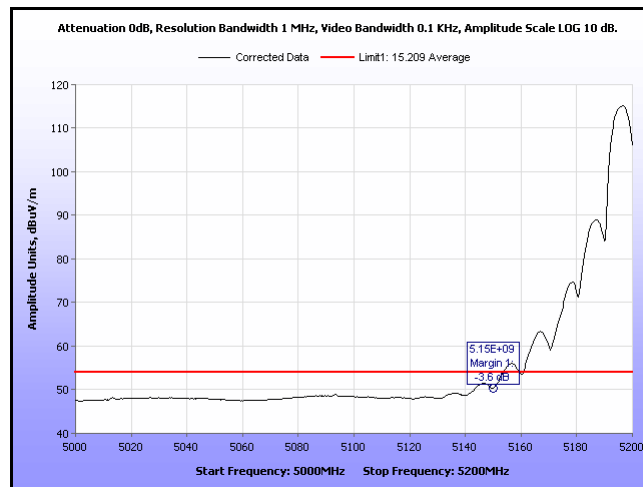

Plot 35. Restricted Band of Operation, 11a, 20MHz, 5200 MHz, OP 22 dB, Average 9 dBi

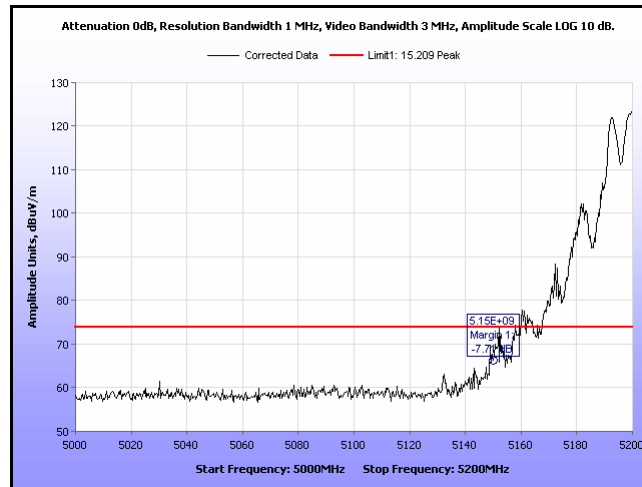

Plot 36. Restricted Band of Operation, 11a, 20MHz, 5200 MHz, OP 22 dB, Peak 9 dBi

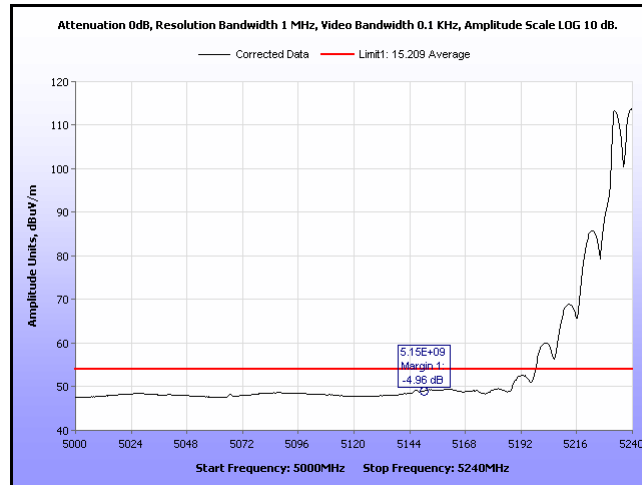

Plot 37. Restricted Band of Operation, 11a, 20MHz, 5240 MHz, OP 22 dB, Average 9 dBi

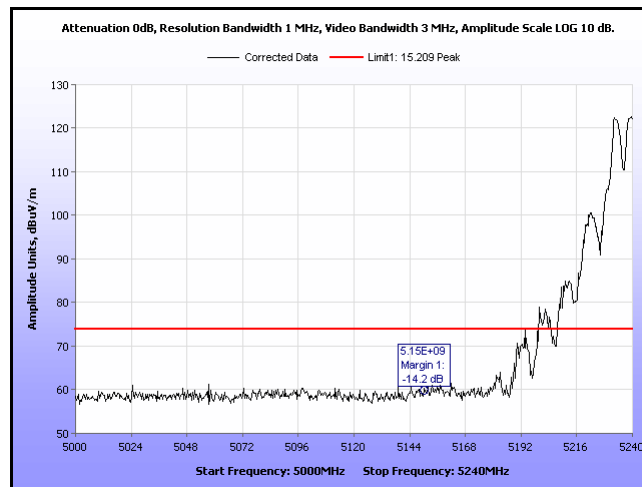

Plot 38. Restricted Band of Operation, 11a, 20MHz, 5240 MHz, OP 22 dB, Peak, 9 dBi

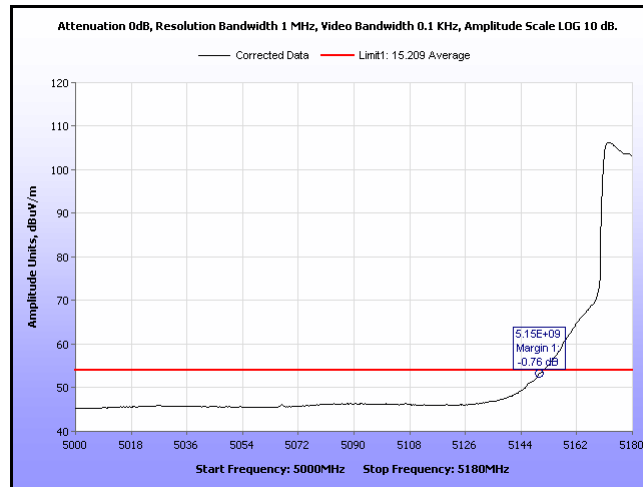

Plot 39. Restricted Band of Operation, 11n, 20MHz, 5180 MHz, OP 15 dB, Average, 9 dBi

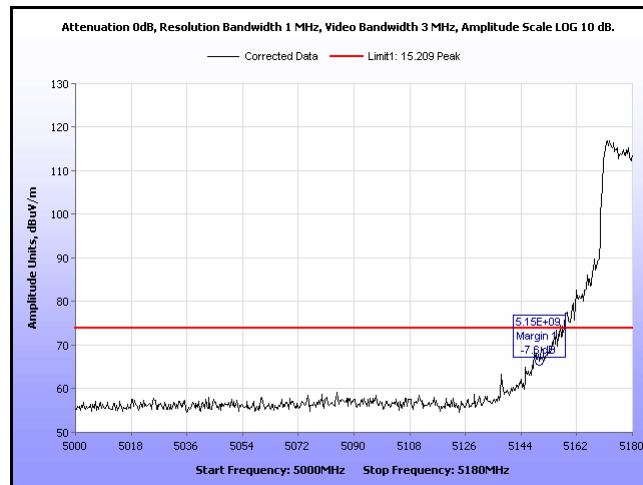

Plot 40. Restricted Band of Operation, 11n, 20MHz, 5180 MHz, OP 15 dB, Peak 9 dBi

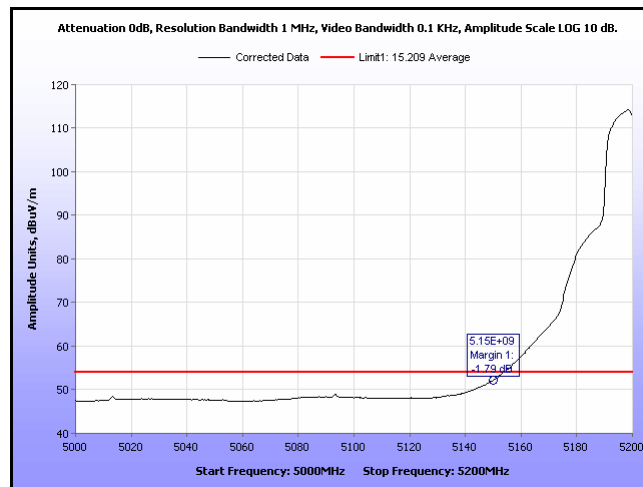

Plot 41. Restricted Band of Operation, 11n, 20MHz, 5200 MHz, OP 21 dB, Average 9 dBi

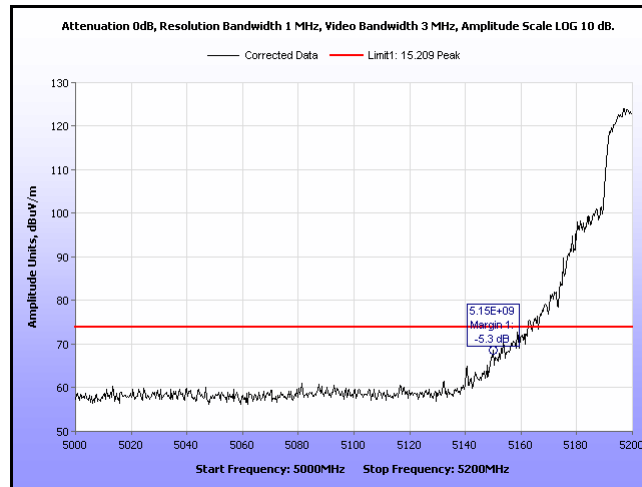

Plot 42. Restricted Band of Operation, 11n, 20MHz, 5200 MHz, OP 21 dB, Peak 9 dBi

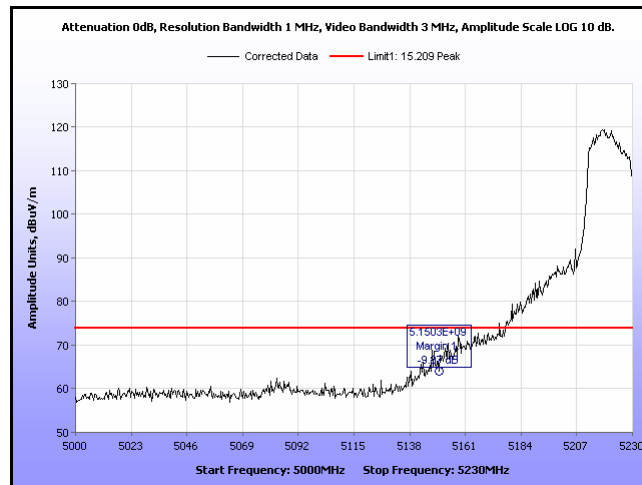

Plot 43. Restricted Band of Operation, 11n, 40MHz, 5230 MHz, OP 18 dB, Peak 9 dBi

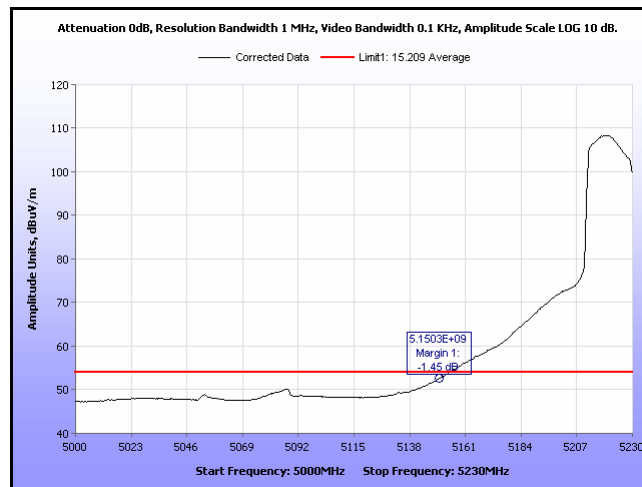

Plot 44. Restricted Band of Operation, 11n, 40MHz, 5230 MHz, OP 18 dB, Average 9 dBi

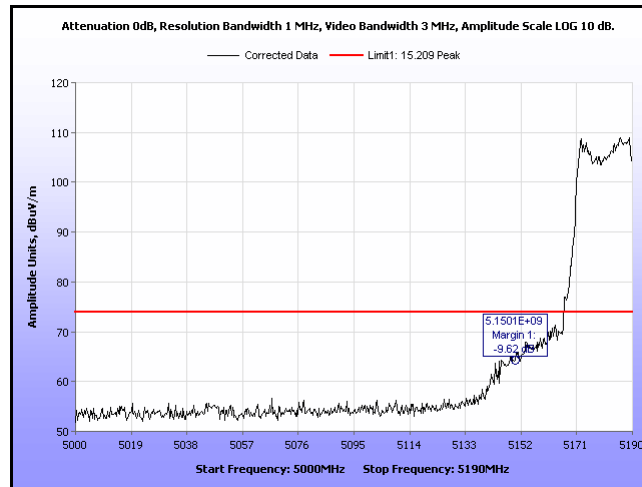

Plot 45. Restricted Band of Operation, 11n, 40MHz, 5190 MHz, OP 9 dB, Peak 9 dBi

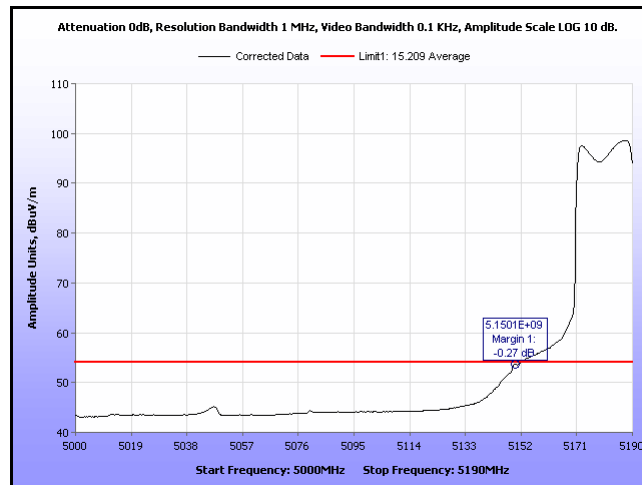

Plot 46. Restricted Band of Operation, 11n, 40MHz, 5190 MHz, OP 9 dB, Average 9 dBi

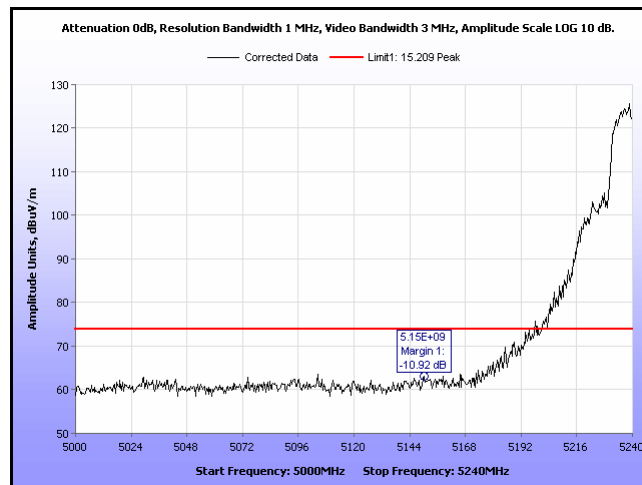

Plot 47. Restricted Band of Operation, 11n, 20MHz, 5240 MHz, OP 22 dB, Peak 9 dBi

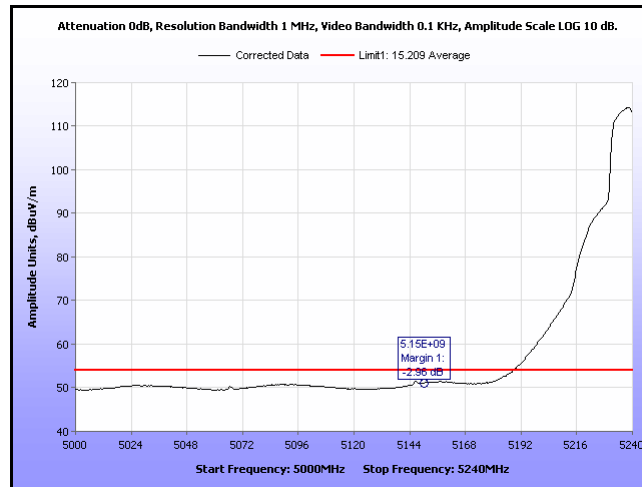

Plot 48. Restricted Band of Operation, 11n, 20MHz, 5240 MHz, OP 22 dB, Average 9 dBi

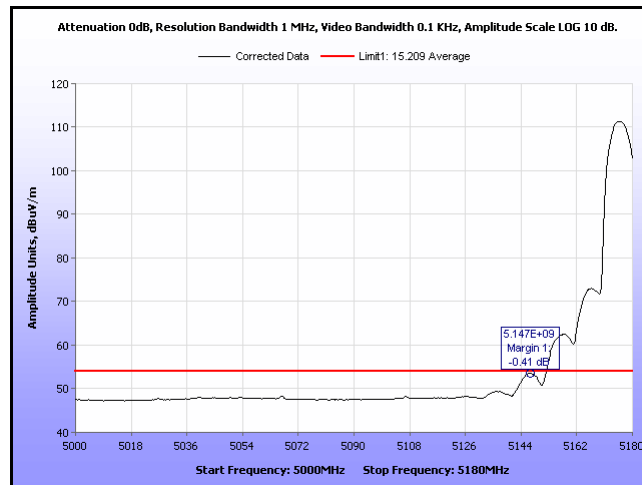

Plot 49. Restricted Band of Operation, 11a, 20MHz, 5180 MHz, OP 17 dB, Average 16 dBi

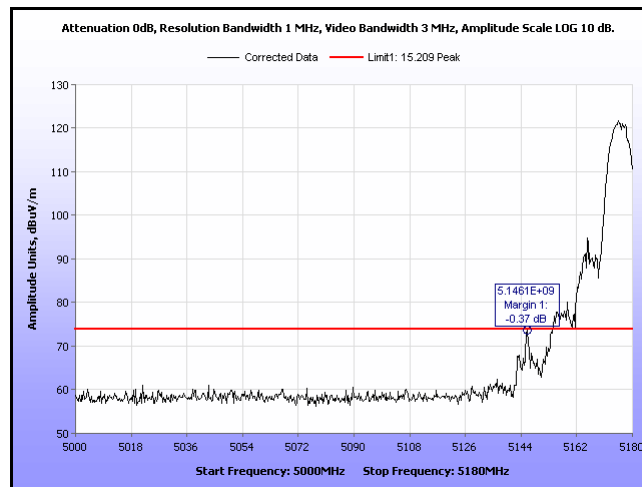

Plot 50. Restricted Band of Operation, 11a, 20MHz, 5180 MHz, OP 17 dB, Peak, 16 dBi

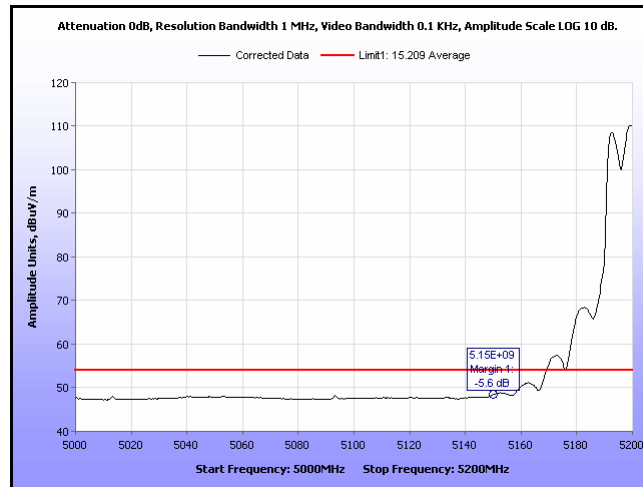

Plot 51. Restricted Band of Operation, 11a, 20MHz, 5200 MHz, OP 17 dB, Average, 16 dBi

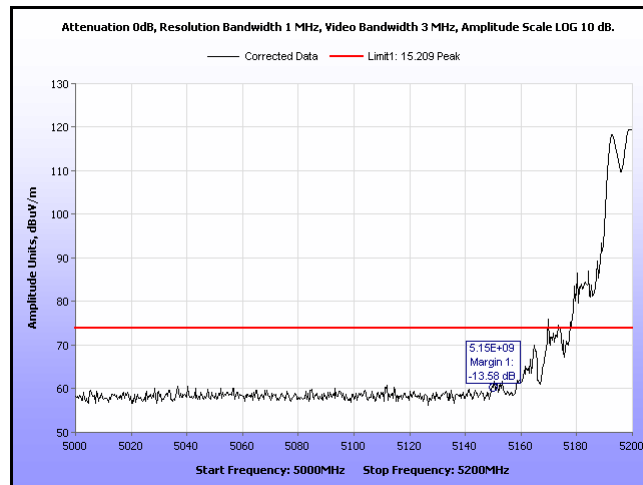

Plot 52. Restricted Band of Operation, 11a, 20MHz, 5200 MHz, OP 17 dB, Peak 16 dBi

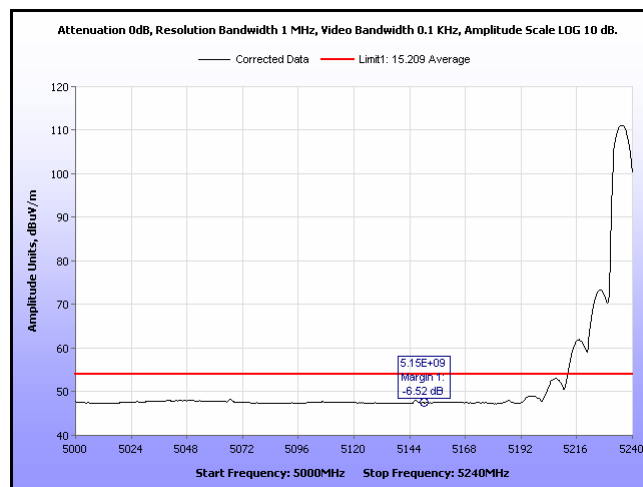

Plot 53. Restricted Band of Operation, 11a, 20MHz, 5240 MHz, OP 17 dB, Average 16 dBi

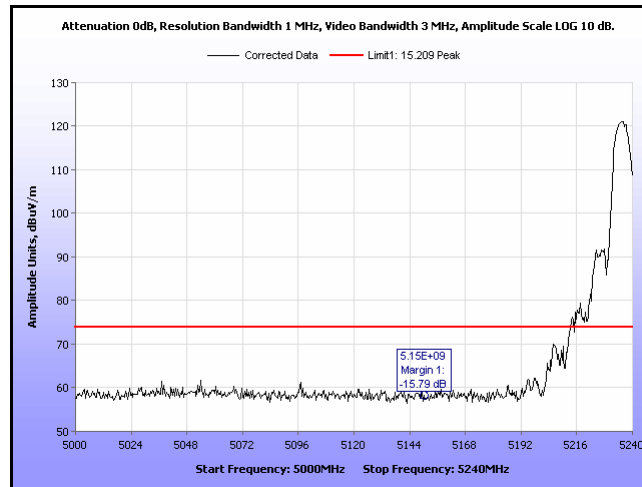

Plot 54. Restricted Band of Operation, 11a, 20MHz, 5240 MHz, OP 17 dB, Peak 16 dBi

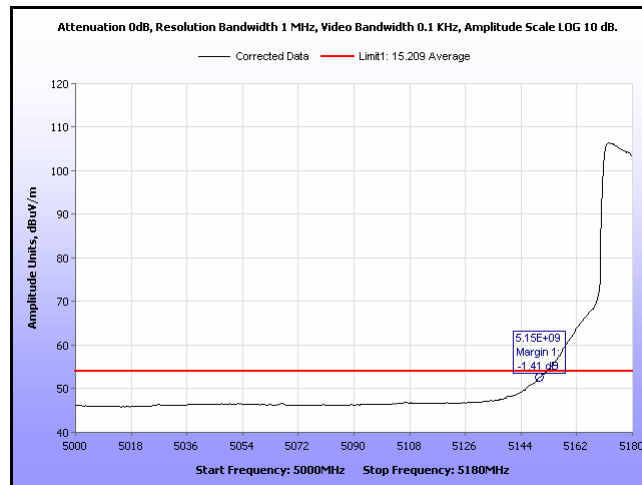

Plot 55. Restricted Band of Operation, 11n, 20MHz, 5180 MHz, OP 15 dB, Average 16 dBi

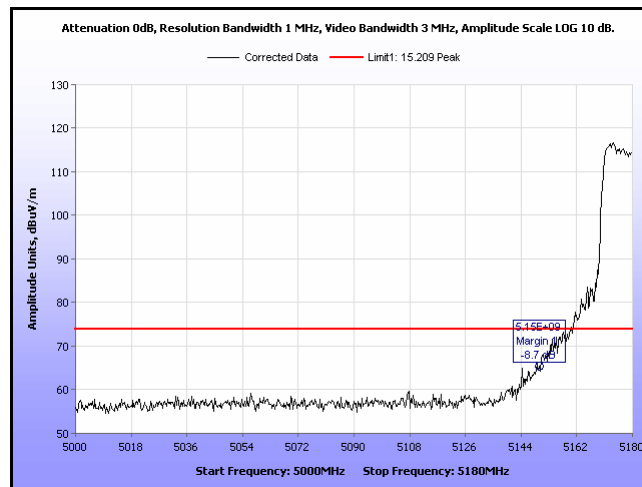

Plot 56. Restricted Band of Operation, 11n, 20MHz, 5180 MHz, OP 15 dB, Peak 16 dBi

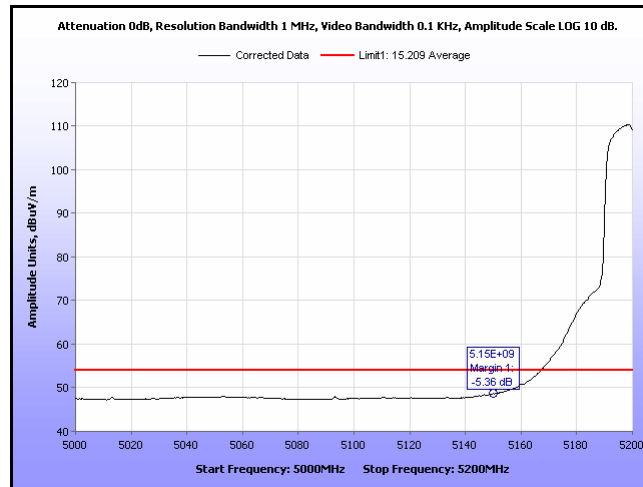

Plot 57. Restricted Band of Operation, 11n, 20MHz, 5200 MHz, OP 17 dB, Average dBi

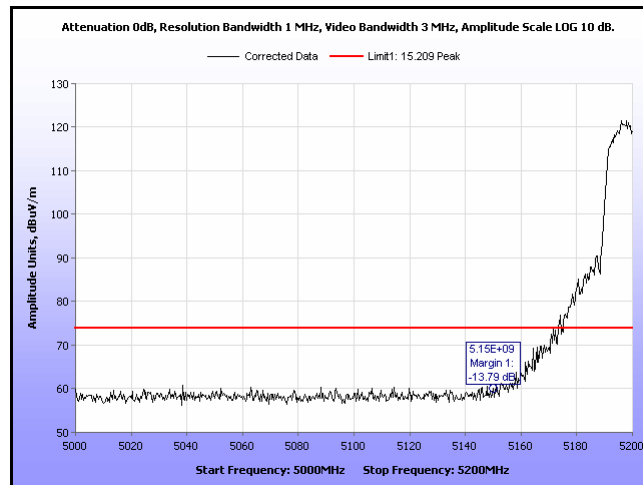

Plot 58. Restricted Band of Operation, 11n, 20MHz, 5200 MHz, OP 17 dB, Peak 16 dBi

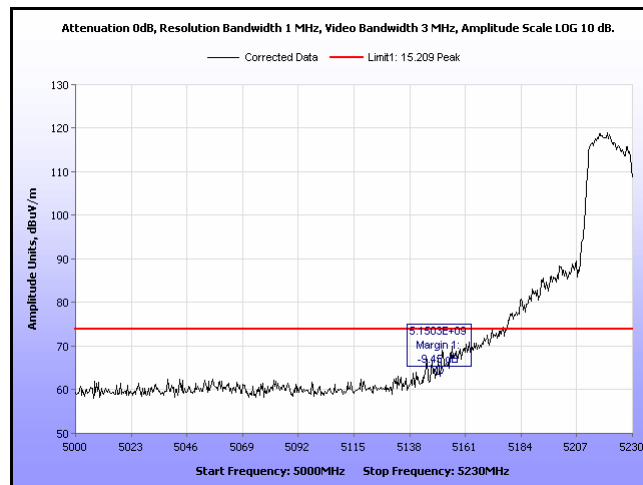

Plot 59. Restricted Band of Operation, 11n, 40MHz, 5230 MHz, OP 18 dB, Peak 16 dBi

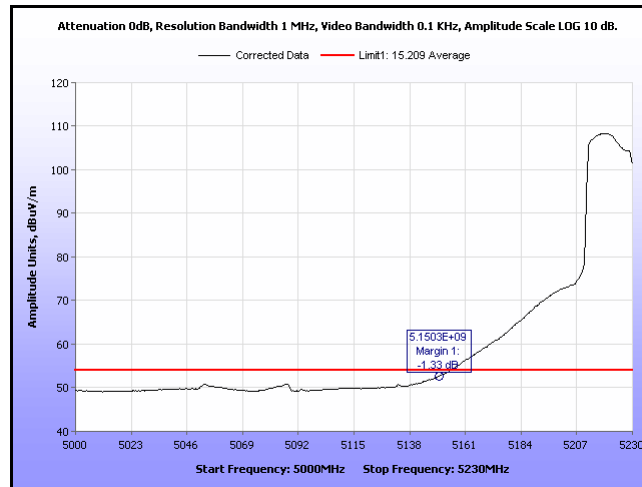

Plot 60. Restricted Band of Operation, 11n, 40MHz, 5230 MHz, OP 18 dB, Average 16 dBi

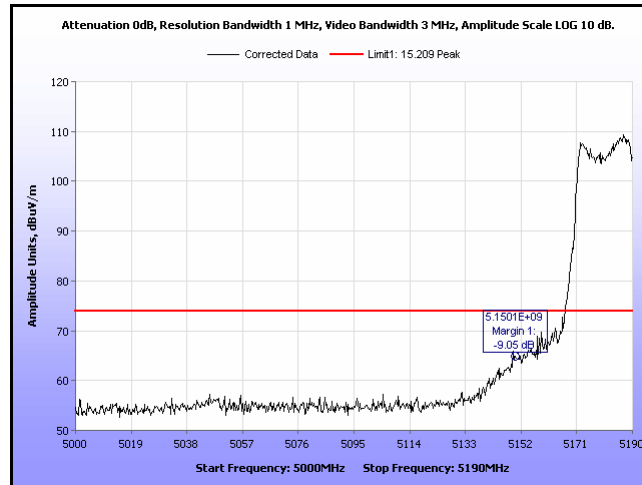

Plot 61. Restricted Band of Operation, 11n, 40MHz, 5190 MHz, OP 7.5 dB, Peak 16 dBi

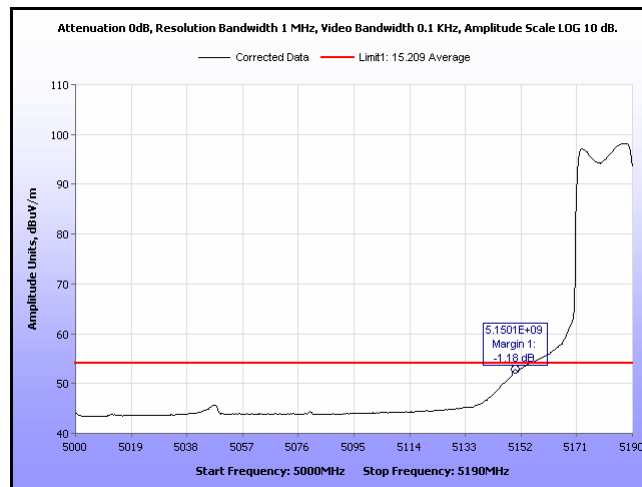

Plot 62. Restricted Band of Operation, 11n, 40MHz, 5190 MHz, OP 7.5 dB, Average 16 dBi

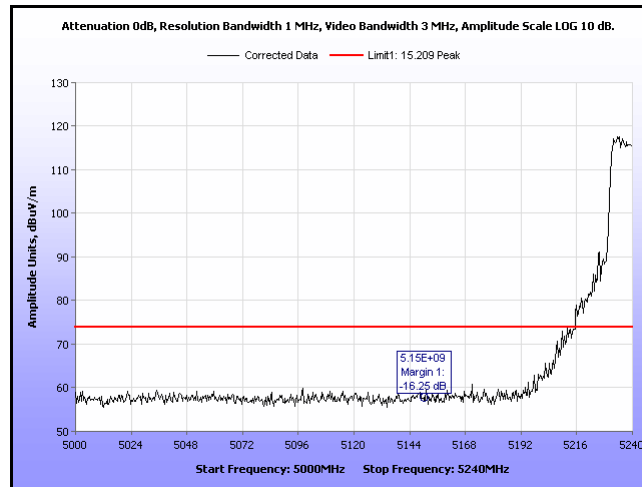

Plot 63. Restricted Band of Operation, 11n, 20MHz, 5240 MHz, OP 17 dB, Peak 16 dBi

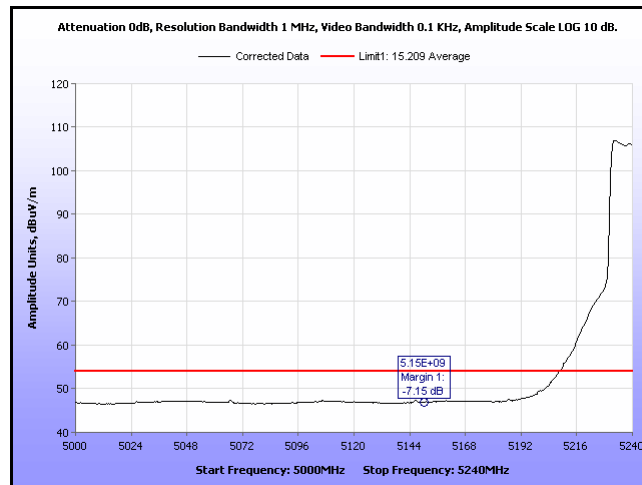

Plot 64. Restricted Band of Operation, 11n, 20MHz, 5240 MHz, OP 17 dB, Average 16 dBi

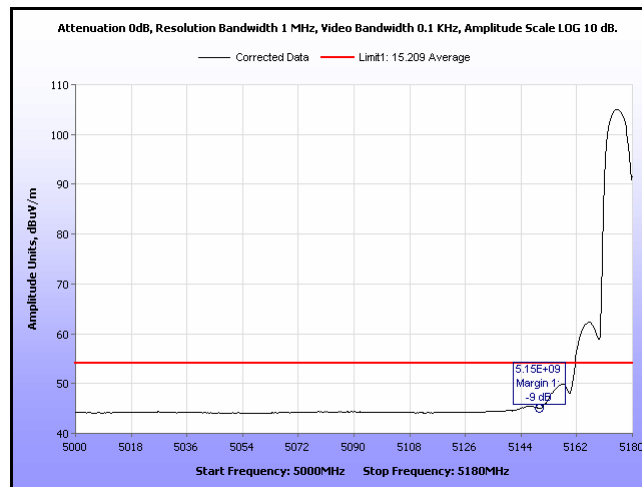

Plot 65. Restricted Band of Operation, 11a, 20MHz, 5180 MHz, OP 9 dB, Average 19 dBi

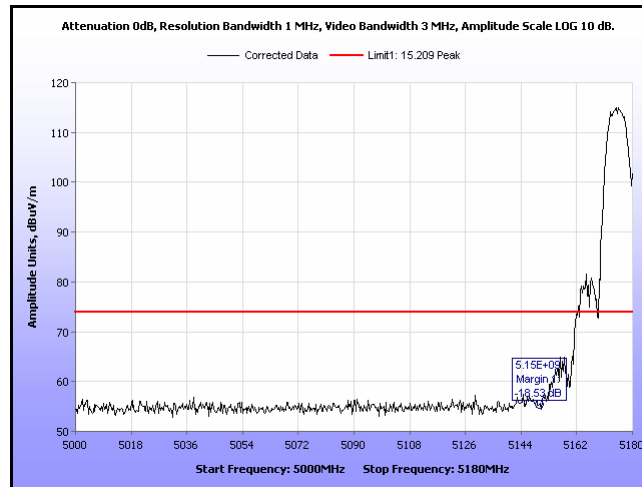

Plot 66. Restricted Band of Operation, 11a, 20MHz, 5180 MHz, OP 9 dB, Peak 19 dBi

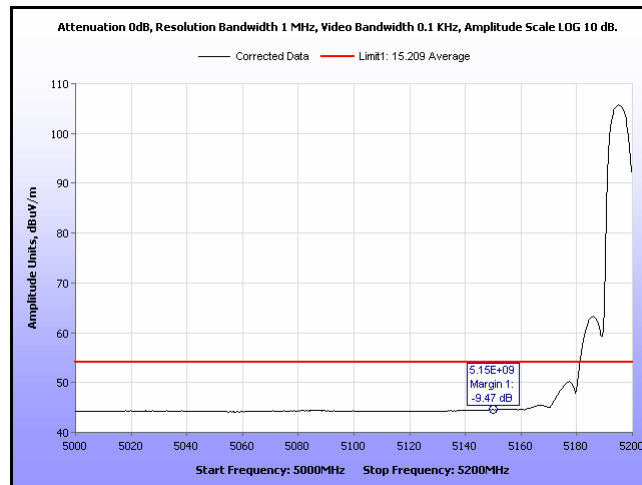

Plot 67. Restricted Band of Operation, 11a, 20MHz, 5200 MHz, OP 9 dB, Average 19 dBi

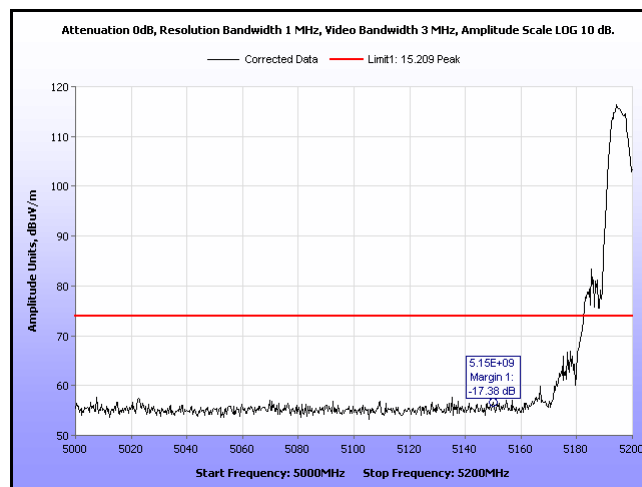

Plot 68. Restricted Band of Operation, 11a, 20MHz, 5200 MHz, OP 9 dB, Peak 19 dBi

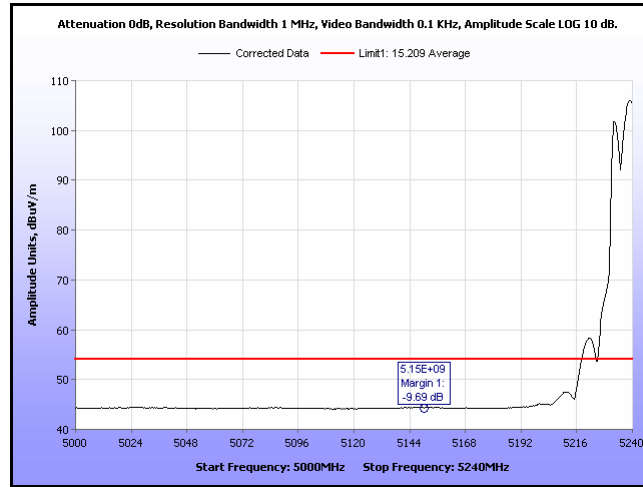

Plot 69. Restricted Band of Operation, 11a, 20MHz, 5240 MHz, OP 9 dB, Average 19 dBi

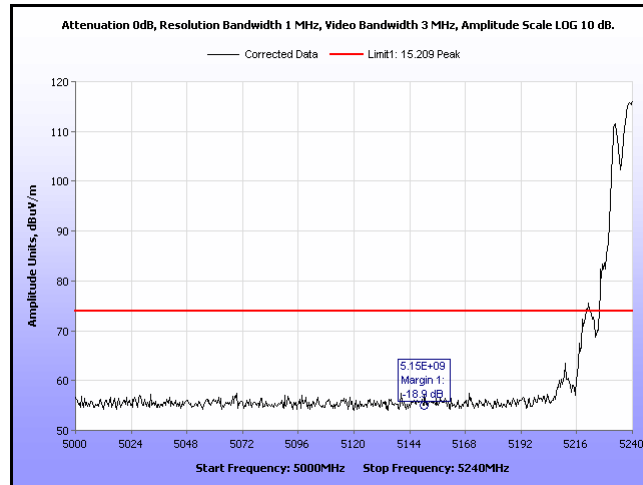

Plot 70. Restricted Band of Operation, 11a, 20MHz, 5240 MHz, OP 9 dB, Peak 19 dBi

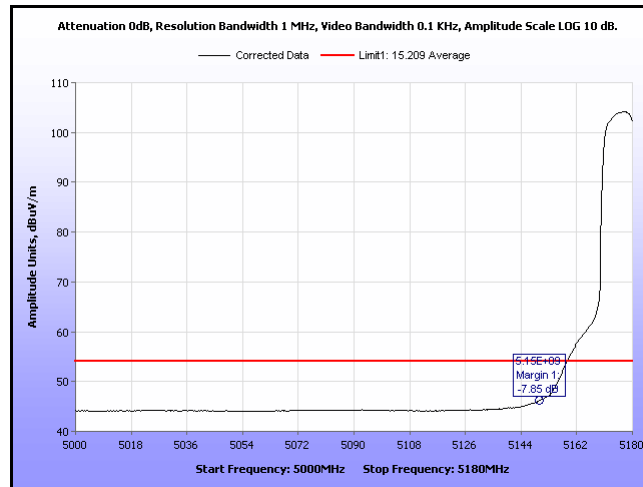

Plot 71. Restricted Band of Operation, 11n, 20MHz, 5180 MHz, OP 9 dB, Average 19 dBi

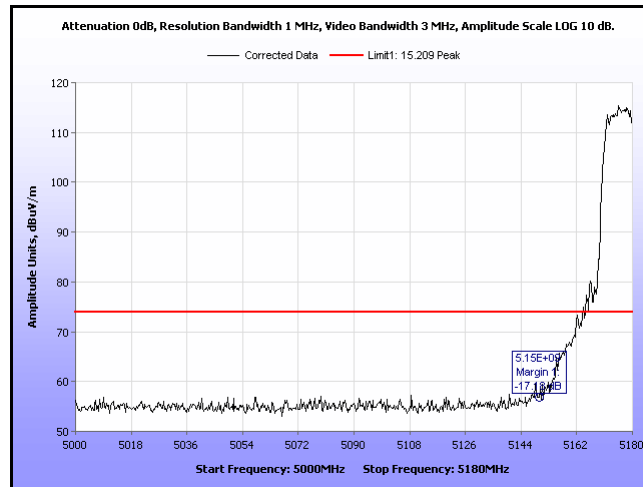

Plot 72. Restricted Band of Operation, 11n, 20MHz, 5180 MHz, OP 9 dB, Peak 19 dBi

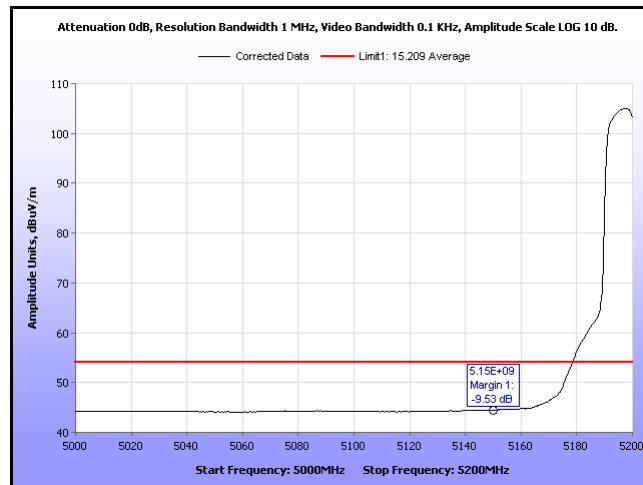

Plot 73. Restricted Band of Operation, 11n, 20MHz, 5200 MHz, OP 9 dB, Average 19 dBi

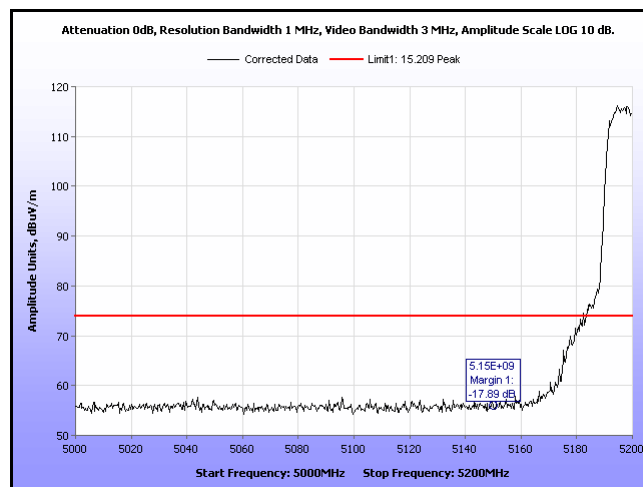

Plot 74. Restricted Band of Operation, 11n, 20MHz, 5200 MHz, OP 9 dB, Peak 19 dBi

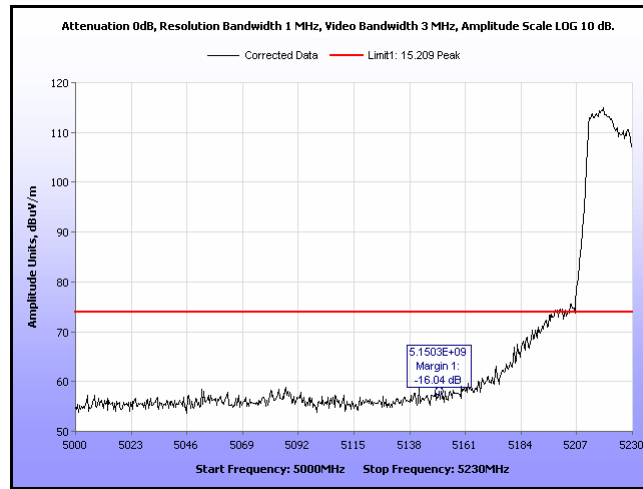

Plot 75. Restricted Band of Operation, 11n, 40MHz, 5230 MHz, OP 11 dB, Peak 19 dBi

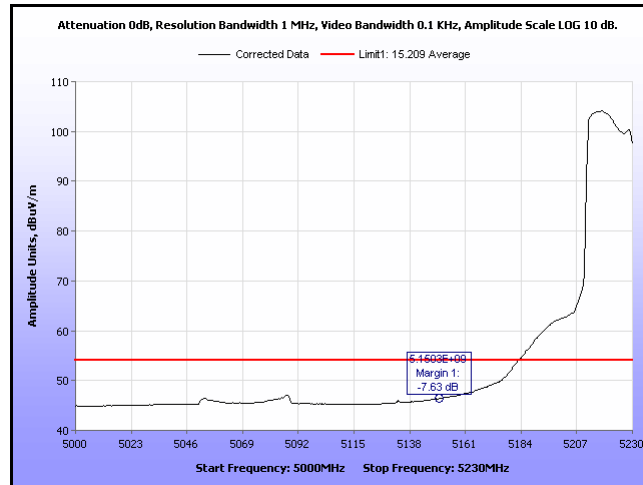

Plot 76. Restricted Band of Operation, 11n, 40MHz, 5230 MHz, OP 11 dB, Average 19 dBi

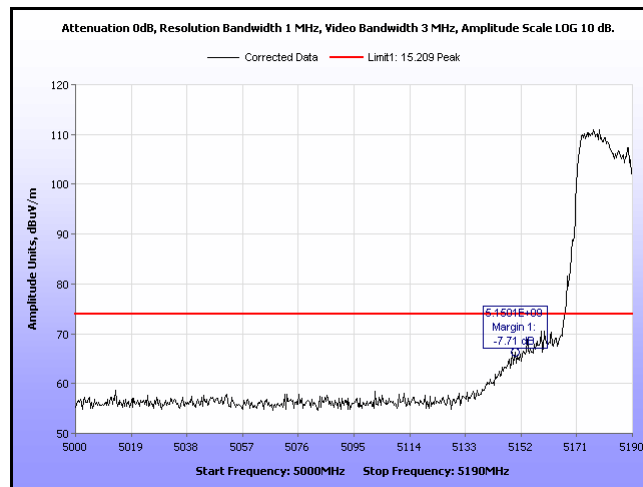

Plot 77. Restricted Band of Operation, 11n, 40MHz, 5190 MHz, OP 6.5 dB, Peak 19 dBi

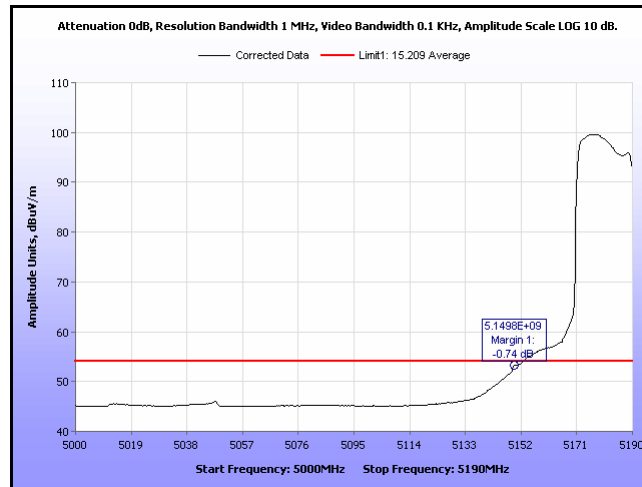

Plot 78. Restricted Band of Operation, 11n, 40MHz, 5190 MHz, OP 6.5 dB, Average 19 dBi

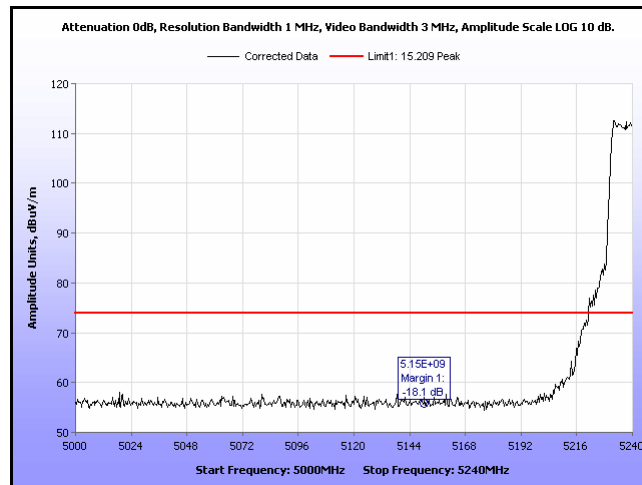

Plot 79. Restricted Band of Operation, 11n, 20MHz, 5240 MHz, OP 9 dB, Peak 19 dBi

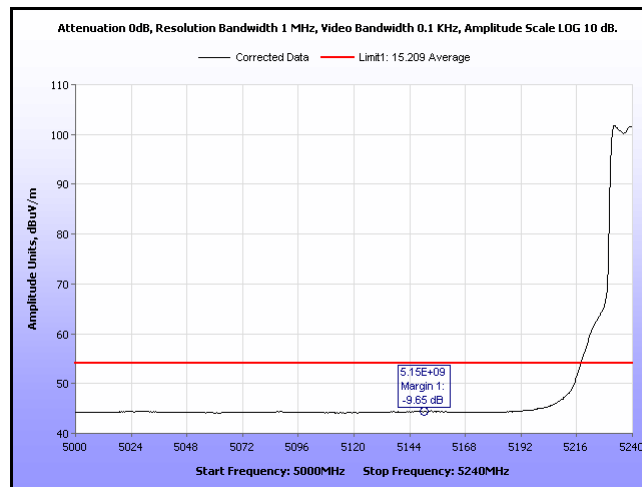

Plot 80. Restricted Band of Operation, 11n, 20MHz, 5240 MHz, OP 9 dB, Average 19 dBi

Below 1 GHz Undesirable Emissions

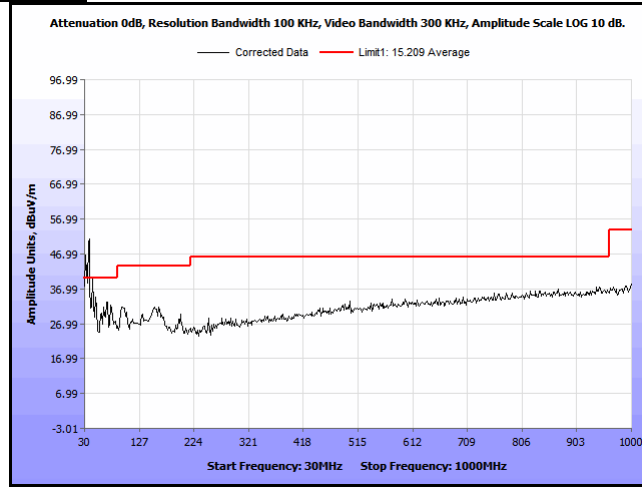

Plot 81. Radiated Spurious Emissions, 11n, 40 MHz, Low, 5190 MHz, OP 23.5 dB, Average 9 dBi

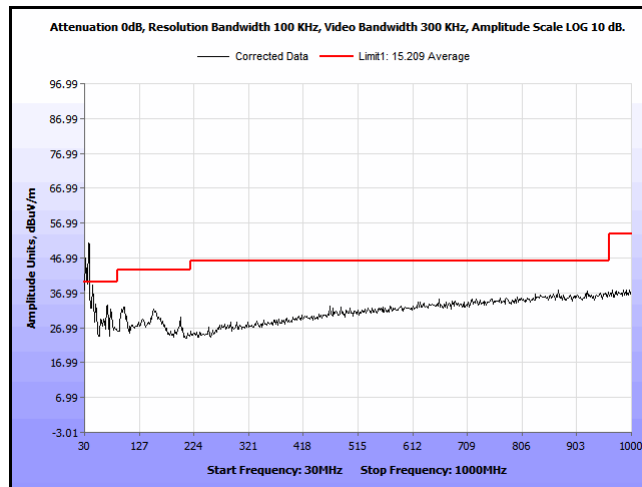

Plot 82. Radiated Spurious Emissions, 11n, 40 MHz, High, 5230 MHz, OP 23.5 dB, Average 9 dBi

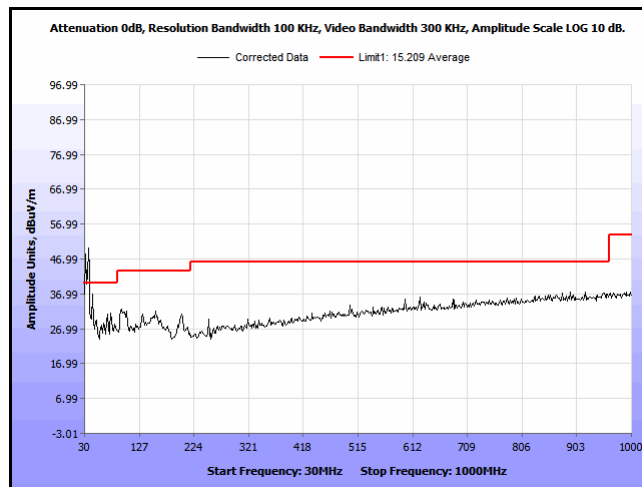

Plot 83. Radiated Spurious Emissions, 11n, 40 MHz, Low, 5190 MHz, OP 19 dB, Average 16 dBi

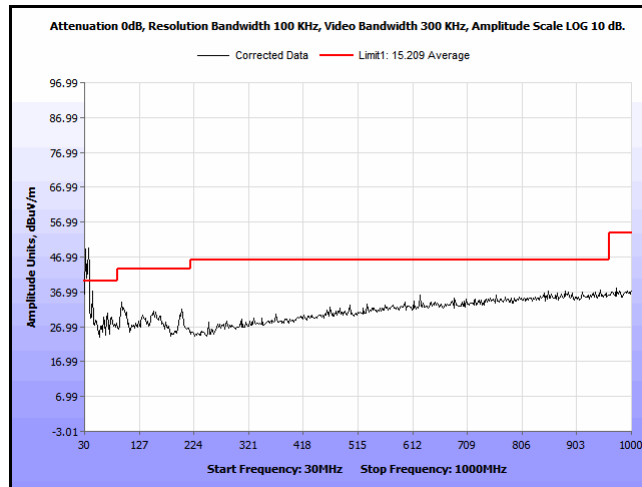

Plot 84. Radiated Spurious Emissions, 11n, 40 MHz, High, 5230 MHz, OP 19 dB, Average 16 dBi

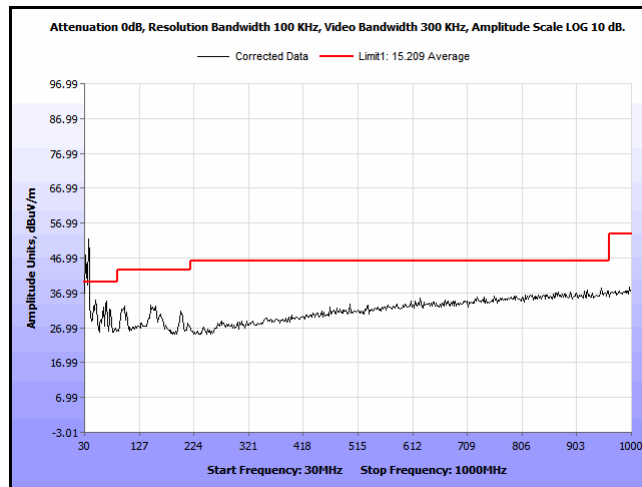

Plot 85. Radiated Spurious Emissions, 11n, 40 MHz, Low, 5190 MHz, OP 11 dB, Average 19 dBi

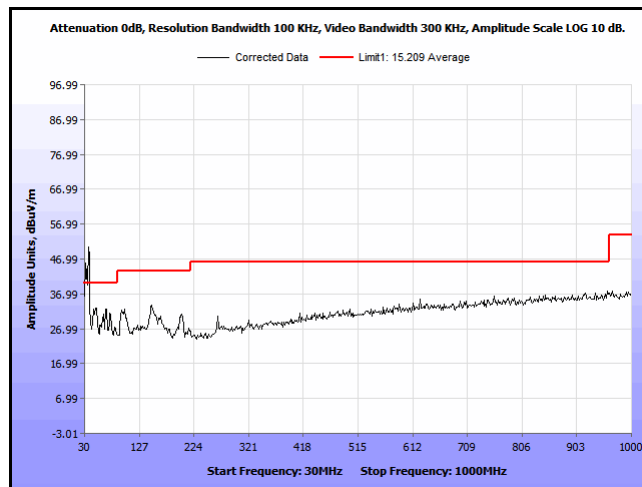

Plot 86. Radiated Spurious Emissions, 11n, 40 MHz, High, 5230 MHz, OP 11 dB, Average 19 dBi

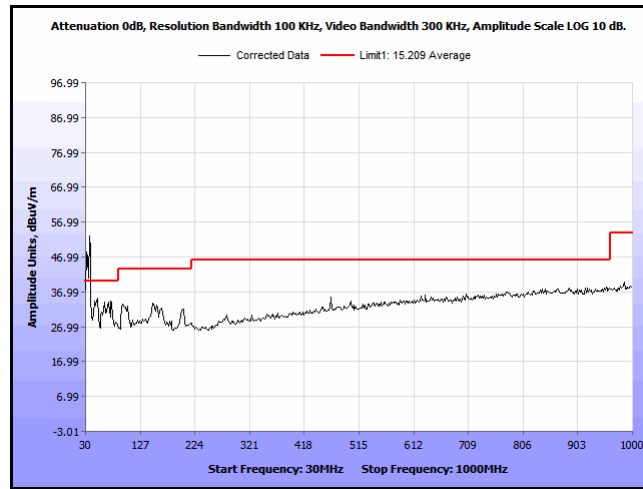

Plot 87. Radiated Spurious Emissions, No Radiate, Power on Only

Electromagnetic Compatibility Criteria for Intentional Radiators

§ 15.407(b)(6) Conducted Emissions

Test Requirement(s): § 15.407 (b)(6): Any U-NII devices using an AC power line are required to comply also with the conducted limits set forth in §15.207.

§ 15.207 (a): For an intentional radiator that is designed to be connected to the public utility (AC) power line, the radio frequency voltage that is conducted back onto the AC power line on any frequency or frequencies, within the band 150 kHz to 30MHz, shall not exceed the limits in the following table, as measured using a 50 μ H/50 Σ line impedance stabilization network (LISN). Compliance with the provisions of this paragraph shall be based on the measurement of the radio frequency voltage between each power line and ground at the power terminal. The lower limit applies at the boundary between the frequency ranges.

Frequency range (MHz)	§ 15.207(a), Conducted Limit (dB μ V)	
	Quasi-Peak	Average
* 0.15- 0.45	66 – 56	56 - 46
0.45 - 0.5	56	46
0.5 - 30	60	50

Table 15. Conducted Limits for Intentional Radiators from FCC Part 15 § 15.207(a)

Test Procedure: The EUT was placed on a non-metallic table inside a screen room. The EUT was situated such that the back of the EUT was 0.4 m from one wall of the vertical ground plane, and the remaining sides of the EUT were no closer than 0.8 m from any other conductive surface. The EUT was powered from a 50 Ω /50 μ H Line Impedance Stabilization Network (LISN). The EMC receiver scanned the frequency range from 150 kHz to 30 MHz. Conducted Emissions measurements were made in accordance with ANSI C63.4-2014 "Methods and Measurements of Radio-Noise Emissions from Low-Voltage Electrical and Electronic Equipment in the Range of 9kHz to 40 GHz". Scans were performed with the transmitter on.

Test Results: The EUT was compliant with requirements of this section.

Test Engineer(s): Jun Qi

Test Date(s): June 21, 2016

Line	Freq (MHz)	QP Amplitude	QP Limit	Delta	Pass	Average Amplitude	Average Limit	Delta	Pass
Line1	0.4956	37.23	56.076	-18.846	Pass	25.6	46.076	-20.476	Pass
Line1	4.5590	30.44	56	-25.56	Pass	22.46	46	-23.54	Pass
Line1	10.6204	31.66	60	-28.34	Pass	23.93	50	-26.07	Pass
Line1	11.7533	32.92	60	-27.08	Pass	25.39	50	-24.61	Pass
Line1	13.1868	32.7	60	-27.3	Pass	25.33	50	-24.67	Pass
Line1	18.5652	31.84	60	-28.16	Pass	25.55	50	-24.45	Pass

Table 16. Conducted Emissions, 15.207(a), Line 1, Test Results

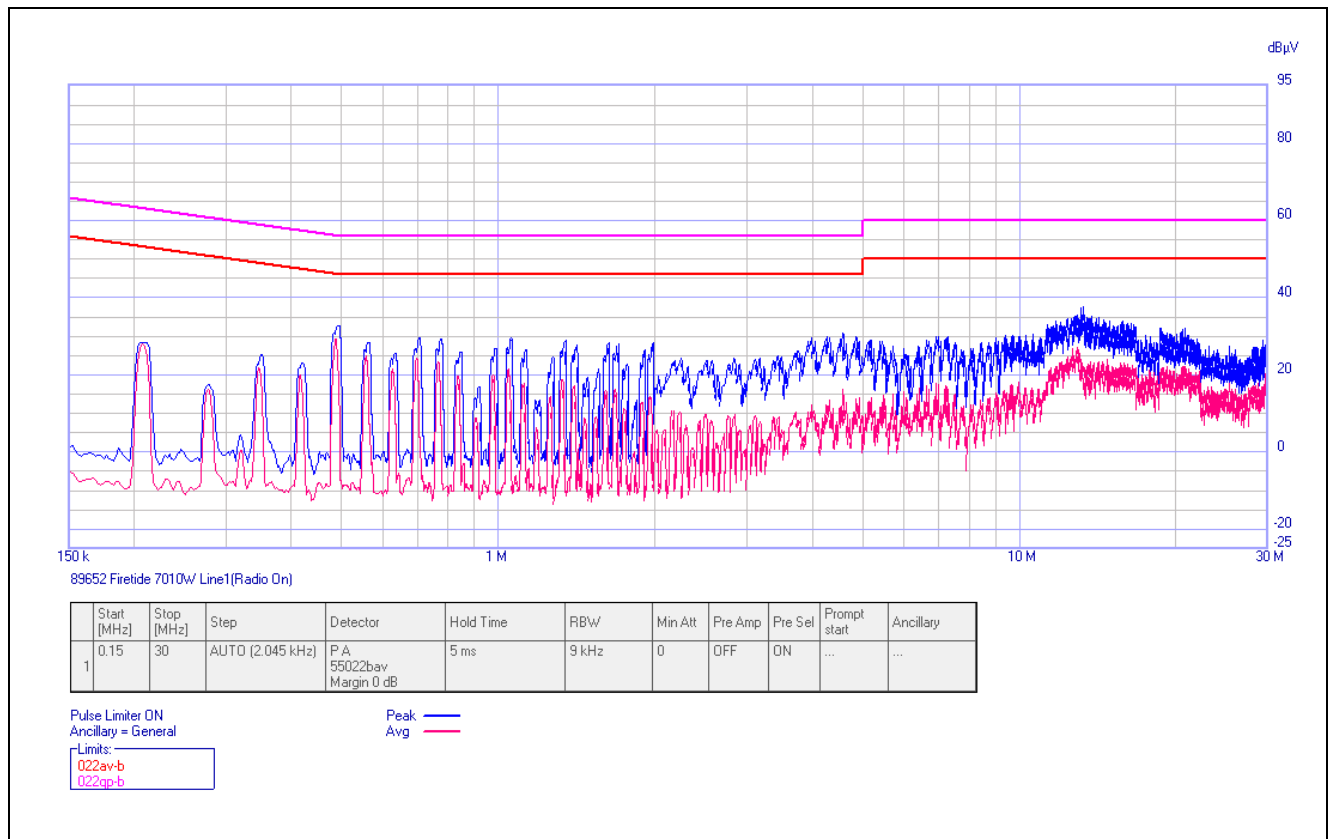

Plot 88. Conducted Emissions, 15.207(a), Line 1

Neutral	0.1909	47.97	64.003	-16.033	Pass	29.99	54.003	-24.013	Pass
Neutral	0.25225	37.27	61.695	-24.425	Pass	22.76	51.695	-28.935	Pass
Neutral	0.45266	36.84	56.85	-20.01	Pass	24.38	46.85	-22.47	Pass
Neutral	12.0928	32.27	60	-27.73	Pass	25.17	50	-24.83	Pass
Neutral	13.0253	32.85	60	-27.15	Pass	25.28	50	-24.72	Pass
Neutral	17.5222	32.45	60	-27.55	Pass	25.91	50	-24.09	Pass

Table 17. Conducted Emissions, 15.207(a), Neutral, Test Results

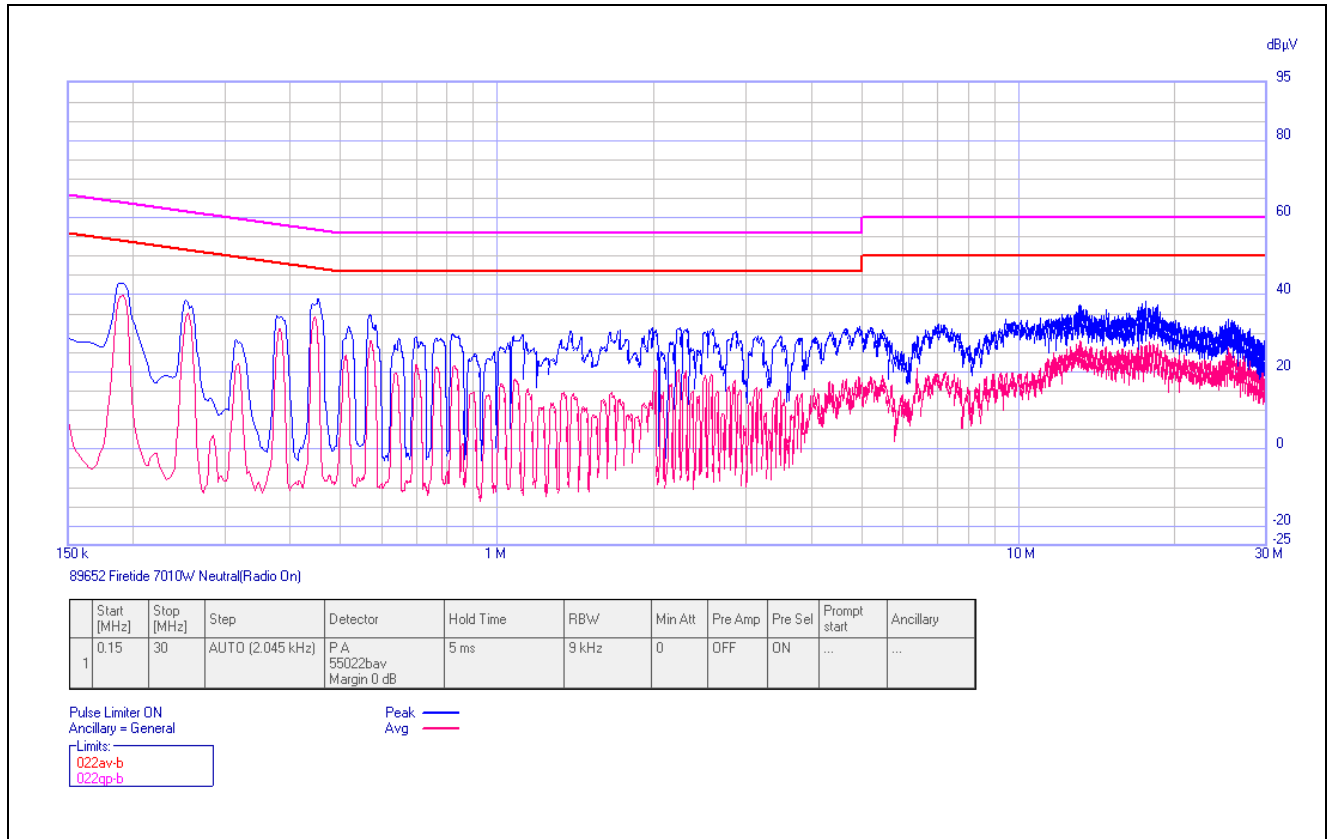

Plot 89. Conducted Emissions, 15.207(a), Neutral Line

Electromagnetic Compatibility Criteria for Intentional Radiators

§ 15.407(c) Automatic Discontinue of Transmission

Test Requirement(s): § 15.207 (c): The device shall automatically discontinue transmission in case of either absence of information to transmit or operational failure. These provisions are not intended to preclude the transmission of control or signaling information or the use of repetitive codes used by certain digital technologies to complete frame or burst intervals.

Test Results: The EUT was not applicable with the requirement of this section.

Electromagnetic Compatibility Criteria for Intentional Radiators

§ 15.407(f) Maximum Permissible Exposure

Test Requirement(s): §15.407(f): U-NII devices are subject to the radio frequency radiation exposure requirements specified in §1.1307(b), §2.1091 and §2.1093 of this chapter, as appropriate. All equipment shall be considered to operate in a “general population/uncontrolled” environment.

RF Exposure Requirements: §1.1307(b)(1) and §1.1307(b)(2): Systems operating under the provisions of this section shall be operated in a manner that ensures that the public is not exposed to radio frequency energy levels in excess of the Commission’s guidelines.

RF Radiation Exposure Limit: §1.1310: As specified in this section, the Maximum Permissible Exposure (MPE) Limit shall be used to evaluate the environmental impact of human exposure to radiofrequency (RF) radiation as specified in Sec. 1.1307(b), except in the case of portable devices which shall be evaluated according to the provisions of Sec. 2.1093 of this chapter.

MPE Limit: EUT’s operating frequencies @ 5150-5250 MHz; **Limit for Uncontrolled exposure: 1 mW/cm² or 10 W/m²**

Equation from page 18 of OET 65, Edition 97-01

$$S = PG / 4\pi R^2 \quad \text{or} \quad R = \sqrt{PG / 4\pi S}$$

where, S = Power Density (mW/cm²)
P = Power Input to antenna (mW)
G = Antenna Gain (numeric value)
R = Distance (cm)

Test Results:

FCC									
Frequency (MHz)	Con. Pwr. (dBm)	Con. Pwr. (mW)	Ant. Gain (dBi)	Ant. Gain numeric	Pwr. Density (mW/cm ²)	Limit (mW/cm ²)	Margin	Distance (cm)	Result
5230	19.61	91.411	16	39.811	0.72399	1	0.27601	20	Pass

Plot 90. RF Exposure, FCC UNII 1, 16 dBi

FCC									
Frequency (MHz)	Con. Pwr. (dBm)	Con. Pwr. (mW)	Ant. Gain (dBi)	Ant. Gain numeric	Pwr. Density (mW/cm ²)	Limit (mW/cm ²)	Margin	Distance (cm)	Result
5190	16.42	43.853	19	79.433	0.693	1	0.307	20	Pass

Plot 91. RF Exposure, FCC UNII 1, 19 dBi

FCC									
Frequency (MHz)	Con. Pwr. (dBm)	Con. Pwr. (mW)	Ant. Gain (dBi)	Ant. Gain numeric	Pwr. Density (mW/cm ²)	Limit (mW/cm ²)	Margin	Distance (cm)	Result
5230	26.77	475.335	9	7.943	0.75116	1	0.24884	20	Pass

Plot 92. RF Exposure, FCC UNII 1, 9 dBi

The safe distance where Power Density is less than the MPE Limit listed above was found to be 20 cm.

Electromagnetic Compatibility Criteria for Intentional Radiators

§ 15.407(g) Frequency Stability

Test Requirements: Manufacturers of U-NII devices are responsible for ensuring frequency stability such that an emission is maintained within the band of operation under all conditions of normal operation as specified in the user's manual.

Test Results: The EUT was not applicable with the requirements of this section.

IV. Test Equipment

Test Equipment

Calibrated test equipment utilized during testing was maintained in a current state of calibration per the requirements of ISO/IEC 17025:2005.

MET Asset #	Equipment	Manufacturer	Model	Last Cal Date	Cal Due Date
1S3914	Spikeguard	FCC	FCC-450B-2.4-N	See Note	
1S3809	EMI CISPR Receiver	Narda Safety Test Solutions	PMM 9010F	2/1/2016	2/1/2017
1U0337	AC LISN	Com Power	LI-215A	5/31/2016	5/31/2017
1S2657	Screen Room	ETS Lindgren	14w-2/2-0	Not Required	
1S2746	Bilog Antenna	Sunol Science	JB3	9/29/2015	3/29/2017
1S2482	5 Meter Chamber (NSA)	Panashield	5 Meter Semi-Anechoic Chamber	See Note	
1S2603	Double Ridged Waveguide Horn	ETS-Lindgren	3117	08/09/2016	08/09/18
1S3962	Spectrum Analyzer (PSA)	Keysight/Agilent	E4448A	02/26/16	02/26/2018
1S2121	Pre-Amplifier	Hewlett Packard	8449B	See Note	
1U0258	Spectrum Analyzer	Agilent Technologies	E4407B	2/2/2016	2/2/2017

Table 18. Test Equipment List

Note: Functionally tested equipment is verified using calibrated instrumentation at the time of testing.

V. Certification & User's Manual Information

Certification & User's Manual Information

L. Certification Information

The following is extracted from Title 47 of the Code of Federal Regulations, Part 2, Subpart I — Marketing of Radio frequency devices:

§ 2.801 Radio-frequency device defined.

As used in this part, a radio-frequency device is any device which in its operation is capable of Emitting radio-frequency energy by radiation, conduction, or other means. Radio- frequency devices include, but are not limited to:

- (a) The various types of radio communication transmitting devices described throughout this chapter.
- (b) *The incidental, unintentional and intentional radiators defined in Part 15 of this chapter.*
- (c) The industrial, scientific, and medical equipment described in Part 18 of this chapter.
- (d) Any part or component thereof which in use emits radio-frequency energy by radiation, conduction, or other means.

§ 2.803 Marketing of radio frequency devices prior to equipment authorization.

- (a) Except as provided elsewhere in this chapter, no person shall sell or lease, or offer for sale or lease (including advertising for sale or lease), or import, ship or distribute for the purpose of selling or leasing or offering for sale or lease, any radio frequency device unless:
 - (1) In the case of a device subject to certification, such device has been authorized by the Commission in accordance with the rules in this chapter and is properly identified and labeled as required by §2.925 and other relevant sections in this chapter; or
 - (2) In the case of a device that is not required to have a grant of equipment authorization issued by the Commission, but which must comply with the specified technical standards prior to use, such device also complies with all applicable administrative (including verification of the equipment or authorization under a Declaration of Conformity, where required), technical, labeling and identification requirements specified in this chapter.
- (d) Notwithstanding the provisions of paragraph (a) of this section, the offer for sale solely to business, commercial, industrial, scientific or medical users (but not an offer for sale to other parties or to end users located in a residential environment) of a radio frequency device that is in the conceptual, developmental, design or pre-production stage is permitted prior to equipment authorization or, for devices not subject to the equipment authorization requirements, prior to a determination of compliance with the applicable technical requirements *provided* that the prospective buyer is advised in writing at the time of the offer for sale that the equipment is subject to the FCC rules and that the equipment will comply with the appropriate rules before delivery to the buyer or to centers of distribution.

- (e)(1) Notwithstanding the provisions of paragraph (a) of this section, prior to equipment authorization or determination of compliance with the applicable technical requirements any radio frequency device may be operated, but not marketed, for the following purposes and under the following conditions:
- (i) *Compliance testing*;
 - (ii) Demonstrations at a trade show provided the notice contained in paragraph (c) of this section is displayed in a conspicuous location on, or immediately adjacent to, the device;
 - (iii) Demonstrations at an exhibition conducted at a business, commercial, industrial, scientific or medical location, but excluding locations in a residential environment, provided the notice contained in paragraphs (c) or (d) of this section, as appropriate, is displayed in a conspicuous location on, or immediately adjacent to, the device;
 - (iv) Evaluation of product performance and determination of customer acceptability, provided such operation takes place at the manufacturer's facilities during developmental, design or pre-production states; or
 - (v) Evaluation of product performance and determination of customer acceptability where customer acceptability of a radio frequency device cannot be determined at the manufacturer's facilities because of size or unique capability of the device, provided the device is operated at a business, commercial, industrial, scientific or medical user's site, but not at a residential site, during the development, design or pre-production stages.
- (e)(2) For the purpose of paragraphs (e)(1)(iv) and (e)(1)(v) of this section, the term *manufacturer's facilities* includes the facilities of the party responsible for compliance with the regulations and the manufacturer's premises, as well as the facilities of other entities working under the authorization of the responsible party in connection with the development and manufacture, but not the marketing, of the equipment.
- (f) For radio frequency devices subject to verification and sold solely to business, commercial, industrial, scientific and medical users (excluding products sold to other parties or for operation in a residential environment), parties responsible for verification of the devices shall have the option of ensuring compliance with the applicable technical specifications of this chapter at each end user's location after installation, provided that the purchase or lease agreement includes a proviso that such a determination of compliance be made and is the responsibility of the party responsible for verification of the equipment.

Certification & User's Manual Information

The following is extracted from Title 47 of the Code of Federal Regulations, Part 2, Subpart J — Equipment Authorization Procedures:

§ 2.901 Basis and Purpose

- (a) In order to carry out its responsibilities under the Communications Act and the various treaties and international regulations, and in order to promote efficient use of the radio spectrum, the Commission has developed technical standards for radio frequency equipment and parts or components thereof. The technical standards applicable to individual types of equipment are found in that part of the rules governing the service wherein the equipment is to be operated.¹ *In addition to the technical standards provided, the rules governing the service may require that such equipment be verified by the manufacturer or importer, be authorized under a Declaration of Conformity, or receive an equipment authorization from the Commission by one of the following procedures: certification or registration.*
- (b) The following sections describe the verification procedure, the procedure for a Declaration of Conformity, and the procedures to be followed in obtaining certification from the Commission and the conditions attendant to such a grant.

§ 2.907 Certification.

- (a) Certification is an equipment authorization issued by the Commission, based on representation and test data submitted by the applicant.
- (b) Certification attaches to all units subsequently marketed by the grantee which are identical (see Section 2.908) to the sample tested except for permissive changes or other variations authorized by the Commission pursuant to Section 2.1043.

¹ In this case, the equipment is subject to the rules of Part 15. More specifically, the equipment falls under Subpart B (of Part 15), which deals with unintentional radiators.

Certification & User's Manual Information

§ 2.948 Description of measurement facilities.

- (a) Each party making measurements of equipment that is subject to an equipment authorization under Part 15 or Part 18 of this chapter, regardless of whether the measurements are filed with the Commission or kept on file by the party responsible for compliance of equipment marketed within the U.S. or its possessions, shall compile a description of the measurement facilities employed.
- (1) If the measured equipment is subject to the verification procedure, the description of the measurement facilities shall be retained by the party responsible for verification of the equipment.
- (i) *If the equipment is verified through measurements performed by an independent laboratory, it is acceptable for the party responsible for verification of the equipment to rely upon the description of the measurement facilities retained by or placed on file with the Commission by that laboratory. In this situation, the party responsible for the verification of the equipment is not required to retain a duplicate copy of the description of the measurement facilities.*
- (ii) If the equipment is verified based on measurements performed at the installation site of the equipment, no specific site calibration data is required. It is acceptable to retain the description of the measurement facilities at the site at which the measurements were performed.
- (2) If the equipment is to be authorized by the Commission under the certification procedure, the description of the measurement facilities shall be filed with the Commission's Laboratory in Columbia, Maryland. The data describing the measurement facilities need only be filed once but must be updated as changes are made to the measurement facilities or as otherwise described in this section. At least every three years, the organization responsible for filing the data with the Commission shall certify that the data on file is current.

Certification & User's Manual Information

Label and User's Manual Information

The following is extracted from Title 47 of the Code of Federal Regulations, Part 15, Subpart A — General:

§ 15.19 Labeling requirements.

(a) *In addition to the requirements in Part 2 of this chapter, a device subject to certification or verification shall be labeled as follows:*

- (1) Receivers associated with the operation of a licensed radio service, e.g., FM broadcast under Part 73 of this chapter, land mobile operation under Part 90, etc., shall bear the following statement in a conspicuous location on the device:

This device complies with Part 15 of the FCC Rules. Operation is subject to the condition that this device does not cause harmful interference.

- (2) A stand-alone cable input selector switch, shall bear the following statement in a conspicuous location on the device:

This device is verified to comply with Part 15 of the FCC Rules for use with cable television service.

- (3) All other devices shall bear the following statement in a conspicuous location on the device:

This device complies with Part 15 of the FCC Rules. Operation is subject to the following two conditions: (1) This device may not cause harmful interference, and (2) this device must accept any interference received, including interference that may cause undesired operation.

- (4) Where a device is constructed in two or more sections connected by wires and marketed together, the statement specified under paragraph (a) of this section is required to be affixed only to the main control unit.

- (5) When the device is so small or for such use that it is not practicable to place the statement specified under paragraph (a) of this section on it, the information required by this paragraph shall be placed in a prominent location in the instruction manual or pamphlet supplied to the user or, alternatively, shall be placed on the container in which the device is marketed. However, the FCC identifier or the unique identifier, as appropriate, must be displayed on the device.

§ 15.21 Information to user.

The users manual or instruction manual for an intentional or unintentional radiator shall caution the user that changes or modifications not expressly approved by the party responsible for compliance could void the user's authority to operate the equipment.

Verification & User's Manual Information

The following is extracted from Title 47 of the Code of Federal Regulations, Part 15, Subpart B — Unintentional Radiators:

§ 15.105 Information to the user.

- (a) For a Class A digital device or peripheral, the instructions furnished the user shall include the following or similar statement, placed in a prominent location in the text of the manual:

Note: This equipment has been tested and found to comply with the limits for a Class A digital device, pursuant to Part 15 of the FCC Rules. These limits are designed to provide reasonable protection against harmful interference when the equipment is operated in a commercial environment. This equipment generates, uses, and can radiate radio frequency energy and, if not installed and used in accordance with the instruction manual, may cause harmful interference to radio communications. Operation of this equipment in a residential area is likely to cause harmful interference in which case the user will be required to correct the interference at own expense.

- (b) For a Class B digital device or peripheral, the instructions furnished the user shall include the following or similar statement, placed in a prominent location in the text of the manual:

Note: This equipment has been tested and found to comply with the limits for a Class B digital device, pursuant to Part 15 of the FCC Rules. These limits are designed to provide reasonable protection against harmful interference when the equipment is operated in a residential environment. This equipment generates, uses, and can radiate radio frequency energy and, if not installed and used in accordance with the instruction manual, may cause harmful interference to radio communications. However, there is no guarantee that interference will not occur in a particular installation. If this equipment does cause harmful interference to radio or television reception, which can be determined by turning the equipment off and on, the user is encouraged to try to correct the interference by one or more of the following measures:

- Reorient or relocate the receiving antenna.
- Increase the separation between the equipment and receiver.
- Connect the equipment into an outlet on a circuit different from that to which the receiver is connected.
- Consult the dealer or an experienced radio/TV technician for help.